

electronics today

NOVEMBER 1978

INTERNATIONAL

Presenting the

ETI TRITON

Home Computer

• Single PCB • Resident BASIC

Inside:
computing
today no1

THE FIRST ISSUE OF OUR NEW
MAGAZINE FOR SMALL SYSTEMS!

Autochord

Venus Probe

Crimson Pre-amp

LCD DFM/Oscillator

... NEWS ... PROJECTS ... MICROPROCESSORS ... AUDIO ...

TRANSCENDENT 2000 SINGLE BOARD SYNTHESIZER

LIVE PERFORMANCE SYNTHESIZER DESIGNED BY CONSULTANT TIM ORR (FORMERLY SYNTHESIZER DESIGNER FOR HEWLETT PACKARD) AND FEATURED AS A CONSTRUCTIONAL ARTICLE IN ELECTRONICS TODAY INTERNATIONAL.

The TRANSCENDENT 2000 is a 3 octave instrument transposable 2 octaves up or down giving an effective 7 octave range. There is continuous sweeping, a 12 frequency and pitch modulation, a VCF with both low and high pass outputs and a separate dynamic sweep control, a noise generator and an ADSR envelope shaper. There is also a new pitch detector, ADSR repeat, sample and hold, and special circuitry with precision components to ensure tuning stability amongst its many features.

The kit includes fully finished metalwork, solid teak cabinet, filter sweep pedal, professional quality components (all resistors either 250 or 1000 ohm 1/4 watt film and 1/2 watt 1% tolerance), a 13A plug in the kit — you need buy absolutely no more parts before enjoying a stimulating musical performance. Virtually all the components are on the one professional quality fibre glass PCB printed with component locations. All the controls mount directly on the board, all connections to the board are made with connector plugs and construction is so simple it can be built easily in a few evenings by almost anyone capable of most electronic work. The synthesizer comparable in performance and quality with ready built units selling for between £500 and £700!

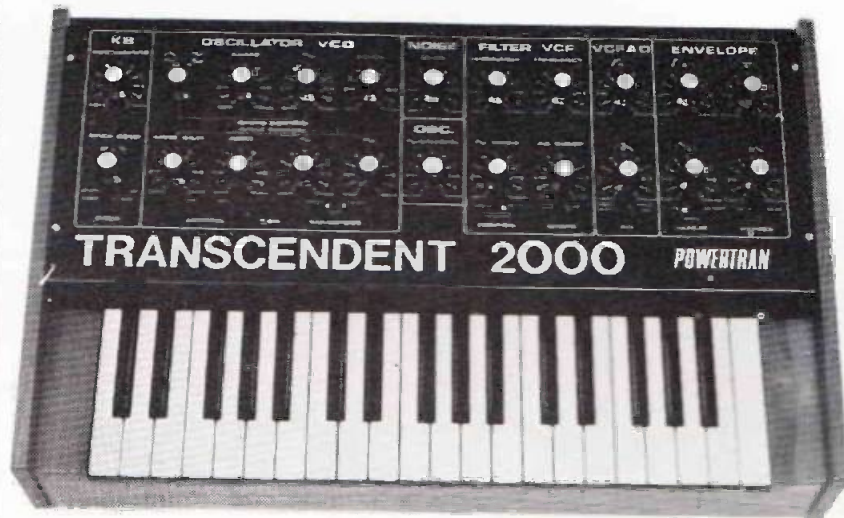

**STILL ONLY
£172.00**

+ VAT

FOR COMPLETE KITS!

Comprehensive handbook supplied with all complete kits! This fully describes instruction and tells you how to set up your synthesizer with nothing more elaborate than a multi-meter and a pair of ears.

Due to the fantastic success in the launching of this superb new kit instead of £186.50 we are able to continue the special introductory offer of £172.00 + VAT!

200 + 200 watt AMPLIFIER

As featured in *Electronics Today International*

400W rms continuous — 800W peak!

0.03% THD at FULL power!

PLUS all the following features too!

- ★ Each channel totally independent with its own stabilised power supply driven by custom designed TOROIDAL transformers!
- ★ Inherent reliability — monster heat sinks for cool running at the hottest venues — electronic open and short circuit protection!
- ★ Ultra low feedback (an incredible low 14dB overall!), super high slewing rate (20V/μs), 200W rms continuous to 4 ohm from EACH channel, input sensitivity 0.775V (0dB).
- ★ Professional quality components, sturdy 19" rack mounting chassis complete with sleeve and feet for free standing work too.
- ★ Easy to build — plenty of working space with ready access to all components, minimal wiring, extensive instruction suitable for both experience constructors and newcomers to electronics.
- ★ Value for money — quality and performance comparable with ready-built amplifiers costing over £600!

**SUPER NEW
LOW PRICES!**

**PSI 4001
COMPLETE KIT ONLY £187.50
+ VAT**

**PSI 4002
COMPLETE KIT ONLY £196.90
+ VAT**

PSI 4001 SLAVE MODEL



PSI 4002 STUDIO MODEL



The kits shown on this page are available as separate packs. Prices are given in the BROCHURE.

PRICE STABILITY: Order with confidence irrespective of any price changes we will honour all prices in this advertisement until November 30th 1978 (ETI October 1978 issue is mentioned with your order. Errors and VAT rate changes excluded.

EXPORT ORDERS: No VAT. Postage charged at actual cost plus 50p handling and documentation.

U.K. ORDERS: Subject to 12% surcharge for VAT (i.e. add 12% to the price). No charge is made for carriage, * or at current rate if changed.

SECURICOR DELIVERY: For this optional service (U.K. mainland only) add £2.50 (VAT inclusive) per kit.

SALES COUNTER: If you prefer to collect your kit from the factory, call in Sales Counter (at rear of factory). Open 9 a.m. - 4.30 p.m. Monday-Thursday.

OUR CATALOGUES ARE FREE! WRITE OR PHONE NOW!

POWERTRAN ELECTRONICS

PORTWAY INDUSTRIAL ESTATE
ANDOVER, HANTS/SP10 3NN

ANDOVER
(STD 0264) 64455

electronics today

NOVEMBER 1978 VOL 7 NO 11

INTERNATIONAL

FEATURES

- NEWS DIGEST **7** Find out here before you hear it elsewhere!
VENUS PROBE **37** Details of the Multiprobe mission.
SWITCH IN LINE SAVES NONE **51** Down with DPDTs at inputs.
GAIN CONTROL PART 2 **65** Concluding Tim Orrs survey.
ULTRASONICS IN MEDICINE **79** Inside information obtained.
AUDIOPHILE **85** DIY Preamp and Sony's new 60 !
TECH TIPS **91** Your circuits to you.

PROJECTS

- ONE BOARD COMPUTER **16** Wow!
TV CHESS PART 2 **44** Full constructional details.
AUTOCHORD **57** Play along with the PROMs?
AUDIO OSCILLATOR **71** LCD DFM option too.

INFORMATION

- SUBSCRIPTIONS **10** Make it easy on yourself.
HOBBY ELECTRONICS **12** Here it comes!
COME AND JOIN US **13** Your ETI needs YOU!
ETI PRINTS **15** The only way to board.
ETI BOOK SERVICE **35** Fine print and proud of it.
ETI SPECIALS **54** All our wares on show.
MARKET PLACE **55** Price reductions here.
DECEMBER PREVIEW **63** What goes in next month.

**COMPUTING TODAY: NEW MAGAZINE FOR SMALL SYSTEMS.
FIRST ISSUE INSIDE.**



what a display p. 16

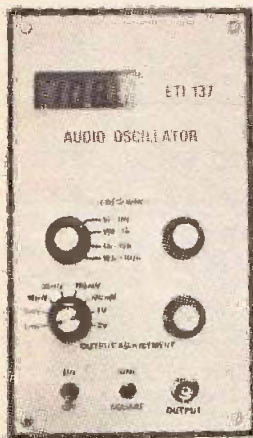

sine of the times p. 71

INTERNATIONAL EDITIONS

- AUSTRALIA** Collyn Rivers
Publisher
Les Bell
Acting Editor
- Holland** Anton Kriegsman
Editor-in-Chief
- CANADA** Steve Braidwood
Editor
Graham Wideman
Assistant Editor
- GERMANY** Udo Wittig
Editor



ABC

EDITORIAL AND ADVERTISEMENT OFFICE

25-27 Oxford Street, London W1R 1RF. Telephone 01-434 1781/2. Telex 8811896

- Halvor W. Moorshead Editor
Ron Harris B.Sc Assistant Editor
Gary Evans Projects Editor
Jim Perry Specials Editor
Phil Cohen B.Sc, William King Editorial Assstants
John Koblanski Project Design
Steve Ramsahadeo Project Development
Paul Edwards Technical Illustrator
Margaret Hewitt Administration
Andrew Scott Office Manager
Kim Hamlin, Bren Goodwin Reader Services
Tim Salmon, Val Tregidgo Advertising
Mark Strathern (Manager), Tom Moloney

PUBLISHED BY Modmags Ltd., 25-27 Oxford Street, London W1R 1RF
DISTRIBUTED BY Argus Distribution Ltd. (British Isles)
Gordon & Gotch Ltd. (Overseas)
PRINTED BY QB Limited, Colchester

Electronics Today International is normally published on the first Friday of the month prior to the cover date

COPYRIGHT: All material is subject to world wide Copyright protection. All reasonable care is taken in the preparation of the magazine to ensure accuracy but ETI cannot be held responsible for it legally. Where errors do occur a correction will be published as soon as possible afterwards.

AUDIO KITS OF DISTINCTION FROM **POWERTRAN**



DE LUXE EASY TO BUILD LINSLEY-HOOD 75W AMPLIFIER £99.30 + VAT

This easy to build version of our world-wide acclaimed 75W amplifier kit based upon circuit boards interconnected with gold plated contacts resulting in minimal wiring and construction delightfully straightforward. The design was published in Hi-Fi News and Record Review and features include rumble filter, variable scratch filter, versatile tone controls and tape monitoring whilst distortion is less than 0.01%.

WIRELESS WORLD FM TUNER £70.20 + VAT

A pre-aligned front-end module makes this Wireless World published design very simple to construct and adjust without special instruments. Features include an excellent m.f.s. rejection, push-button station selection as well as infinitely variable tuning and a phase locked loop stereo decoder incorporating active filters for 'birdy' suppression.



LINSLEY-HOOD CASSETTE DECK £79.60 + VAT

This design, published in Wireless World, although straightforward and relatively low cost provides a very high standard of performance. There are separate record and replay amplifiers and switchable equalisation together with a choice of bias levels are also provided. The mechanism is the Goldring-Lenco CRV with electronic speed control.

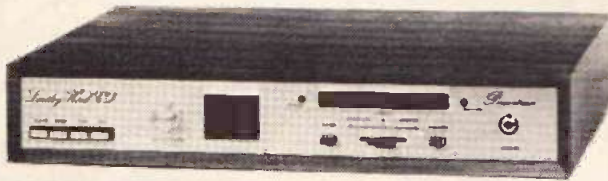

T20 + 20 AMPLIFIER £33.10 + VAT

This kit, based upon a design published in Practical Wireless, uses a single printed circuit board and offers at very low cost, ease of construction and all the normal facilities found on quality amplifiers. A 30 watt version of this kit (T30 + 30) is also available for £38.40 + VAT.

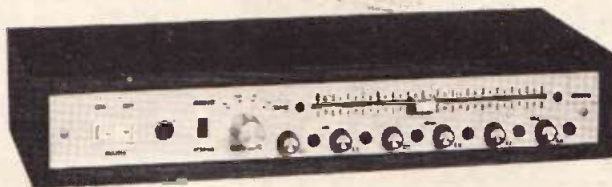

WWII TUNER £47.70 + VAT

This cost reduced model of our highly successful Wireless World FM Tuner kit was designed to complement the T20 + 20 and T30 + 30 amplifiers and the cabinet size, front panel format and electrical characteristics make this tuner compatible with either. Facilities included are pre-aligned front-end module, switchable a.f.c., adjustable switchable muting, LED tuning indication and both continuous and push-button channel selection (adjustable by controls on the front panel).

POWERTRAN SFMT TUNER £35.90 + VAT

This is a simple low cost design which can be constructed easily without special alignment equipment but which still gives a first class output suitable for feeding any of our very popular amplifiers or any other high quality audio equipment. A phase-locked-loop is used for stereo decoding and controls include switchable a.f.c., switchable muting and push-button channel selection (adjustable by controls on the front panel). This unit matches well with the T20 + 20 and T30 + 30 amplifiers.

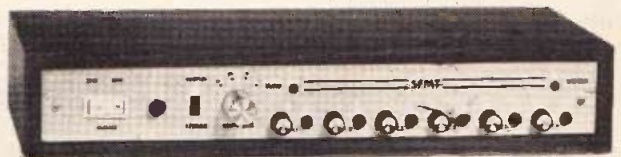

COMPLETE KITS: Our complete kits really are complete. All of the projects shown on this page are supplied with fully finished metalwork, ready assembled high quality teak veneer cabinet, cables, nuts, bolts, etc., and full instructions — in fact everything!

All of the kits shown on this page are available as separate packs (except the Powertran SFMT Tuner) for those customers who wish to spread their purchase or perhaps make their own cabinets or metalwork. Prices are given in our FREE CATALOGUE.

PRICE STABILITY: Order with confidence! irrespective of any price changes. We will honour all prices in this advertisement until November 30th, 1978. If ETI October, 1978 issue is mentioned with your order. Errors and VAT rate changes excluded.

EXPORT ORDERS: No VAT. Postage charged at actual cost plus 50p handling and documentation.

U.K. ORDERS: Subject to 12% surcharge for VAT* (i.e. add 1/6 to the price). No charge is made for carriage, or at current rate if changed.

SECURICOR DELIVERY: For this optional service (U.K. mainland only) add £2.50 (VAT Inclusive) per kit.

SALES COUNTER: If you prefer to collect your kit from the factory, call at Sales Counter (at rear of factory). Open 9 a.m.-4.30 p.m. Monday-Thursday.

OUR CATALOGUE IS FREE! WRITE OR PHONE NOW!

POWERTRAN ELECTRONICS

PORTWAY INDUSTRIAL ESTATE
ANDOVER HANTS SP10 3NM

ANDOVER
(0264) 64455

news digest

dmm(digital midget meter?)

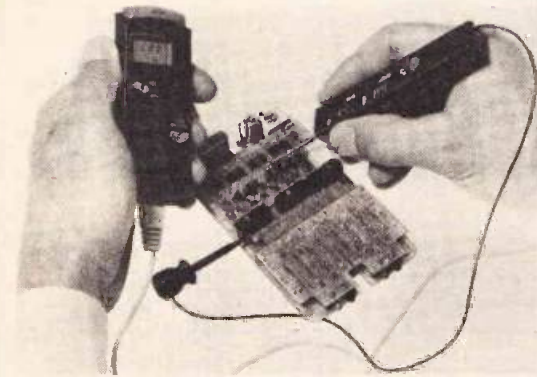

Guinness take note — the world's smallest DMM it seems. Made by Heuer Time Ltd it measures just 4" x 1.6" x 0.5" (100 x 40 x 20mm to you Euro-people) with a probe which is 4" x 0.8" x 0.5" (you mm lot can work that out yourselves). Volts Ohms and Amps either DC or AC can be accommodated between 2V-1kV, 2mA-2A and 2k-20M although not necessarily in that order. AC measurement is true RMS. Display is 3½ digit LCD. Input 7 10M + Price around £240. Address: Heuer Ltd, Argyle House, 29/31 Euston Road, London.

the dalek connection

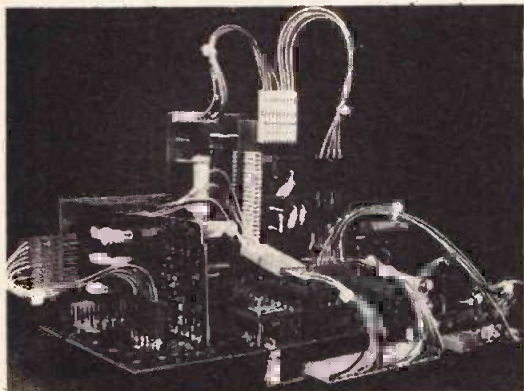

This lot looks like it could give Dr Who a few sleepless nights does it not? It's easy to imagine it lumbering across a smoke-circled hill and intoning "Take me to your leader."

Perhaps fortunately for the human race it is simply a noteworthy new connection system from Pressac Ltd. The PCB mounting plugs and sockets can be got at from either direction, and cable and chassis mounting assemblies are also available. Spacing can be either 2.5mm or 5.0mm and up to 40 ways are possible.

Pressac Ltd, Acton Grove, Long Easton, Nottingham NG10 1FW.

eye of the tornado?

Britain and NATO's new aircraft the MRCA Tornado is to be fitted — in its inceptor role — with a Visual Augmentation System developed by Marconi. The system presents the crew with a television picture of what lies ahead of their machine using a newly-developed low-light TV camera system.

Based on an existing Marconi design for a low light camera, the equipment produces an image at ranges far in excess of what the unaided eye can manage, and in light conditions anywhere from daylight to starlight.

Every little helps. . . .

on the face of it

It had to come. Someone somewhere had to go produce an ANALOGUE digital watch. And here we have it. Must confess it looks very nice too. Texas get the credit/blame or whatever.

The display is beautiful. 120 segments are used to produce the illusion of the dial. On normal LCD's up to half the area is used for contacts to the segments, which would mean that with 121 contacts to provide the display would have to be pretty big — a clock yes, but no watch. Texas have gotten this by multiplexing the drive to the segments, which allows 90% of the area to be freed for usage.

The chip is I²L — and this is unusual. I²L is not normally employed in LCD units because of the problem of driving the highly capacitive elements. Bipolar drivers are used to avoid this; and are designed to drive the large capacitance with a (relatively) large 150µA initial current for about 100 µs and to provide the 100 nA 'sustan' current thereafter.

Another interesting point is that the material used for the display, a low voltage ester material would not usually be employed in watches because of its negative temp. Coeff. — higher the temp. the lower the drive required — which can lead to 'ghosting' and confusion of the display. The I²L however can compensate for this.

Naturally, since this is the first of its kind, the price of all this invention will be high initially — but the watch will function as a chronograph too and the Jones's will NEVER be able to keep up with this.

In the shops soon we hear.

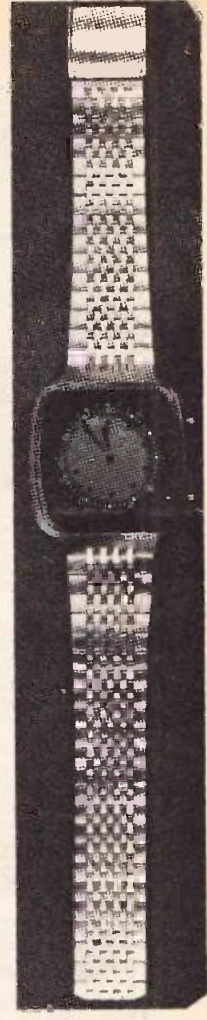

watt batteries

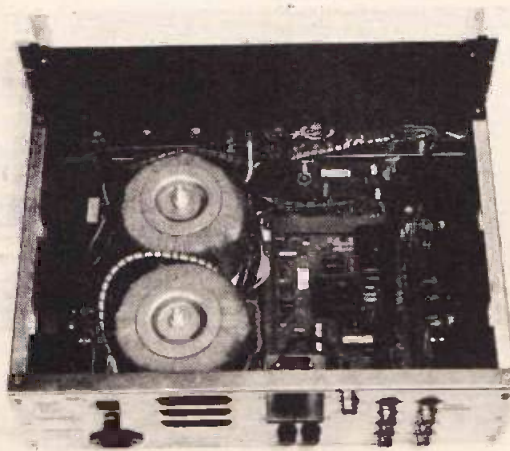

Here is an amp to really annoy the neighbours with. If they complain about the hi-fi again, pack up the battery cassette recorder, speakers and this PAC 250 MB, drive around the back of the house and when they're least expecting it give 'em 250W a channel straight in the back door. An outflanking move to warm Napoleon's heart.

The PAC 250 you see will run quite happily from 24V DC or 250V AC. Very handy for PA as well as neighbour baiting.

Details from: Millbank Electronics Ltd, Uckfield, Sussex TB22 1PS.

Sound of safety?

A car alarm which operates on the ultrasonic area protection principle usually employed in houses is now being imported from the land of pasta and pinched bottoms.

Called the 'Break' it uses four sensors to cover the interior of any vehicle, and has adjustable sensitivity so that spurious triggering can be avoided. Once activated you have 40 secs to clear out before it goes off — so don't get stuck in the seat belt — and coming back in 10 secs to switch it off.

Once the alarm is in mid sing-song, the removal of the felen will lead to a shutdown 15 secs later. If he persists so will the alarm. Price around £50 — not including ear plugs — from:

Sofare Ltd, Stoke Heath, Market Drayton, Shropshire.

NON-SUBSCRIBERS START HERE

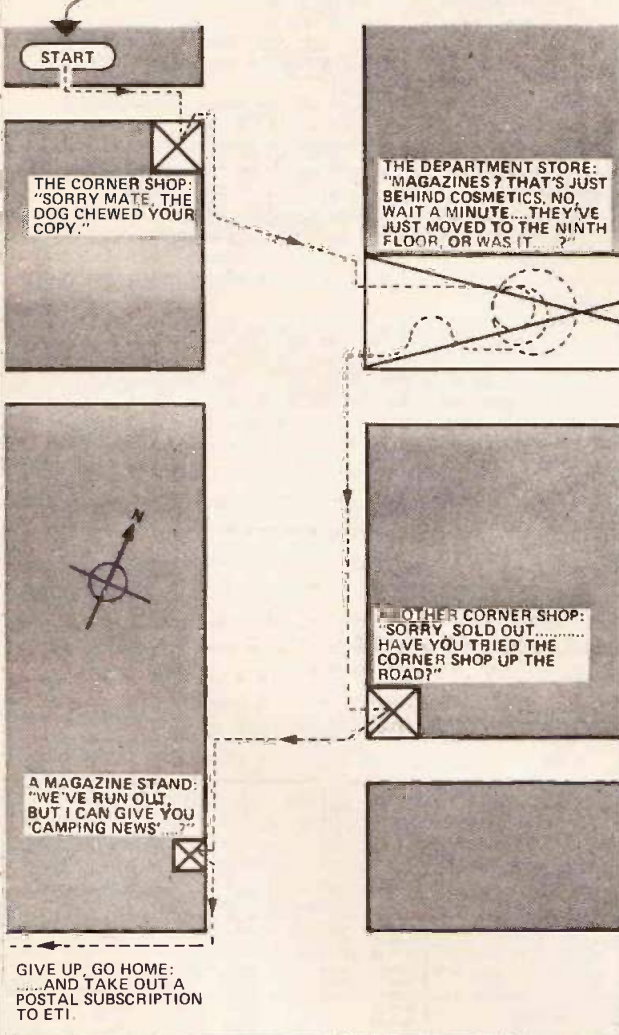

It can be a nuisance can't it, going from newsagent to newsagent? "Sorry squire, don't have it — next one should be out soon."

Although ETI is monthly, it's very rare to find it available after the first week. If it is available, the newsagent's going to be sure to cut his order for the next issue — but we're glad to say it doesn't happen very often.

Do yourself, your newsagent and us a favour. Place a regular order for ETI; your newsagent will almost certainly be delighted. If not, you can take out a postal subscription so there's nothing for you to remember — we'll do it for you.

For a subscription, send us £7.00 (£8.00 overseas) and tell us which issue you want to start with. Please make your payment (in sterling please for overseas readers) to ETI Subscriptions and keep it separate from any other services you want at the same time.

ETI Subscription Service
Electronics Today International
25-27 Oxford Street, London W1R 1RF

- TANTALUM CAPACITORS.** 1uf 35v.w., .47uf 35v.w., 1uf 35v.w., 2uf 35v.w., 3.3uf 16v.w., 4.7uf 35v.w., 6.8uf 25v.w., 6.8uf-35v.w., 10uf 25v.w., 20uf 6v.w., 22uf 16v.w., 33uf 25v.w., 47uf 6v.w. All at 9p each
- CLOCK P.C. BOARDS** with Buzzer, Mercury Switch, Transistors, Only I.C. and Display missing @ £1.
- .01uf 125v.w. + 10% CAPACITORS** @ 10p each
- JACKSON C801 VARIABLE CAPACITORS** 5pf or 10pf. Both 75p each
- ELECTRET MICROPHONE INSERT WITH FET PRE-AMP** @ £1.85
- 400mW UNMARKED GOOD ZENERS** 3.6v, 6.8v, 10v, 11v, 12v, 13v, 16v, 24v, 30v, 33v, 36v. All at 10 for 40p.
- X BAND GUNN DIODES** with data @ £1.65
- X BAND TUNING VARACTOR DIODES** 1 To 2pf or 3 To 4pf. Both £1.65 each
- 10 AMP S.C.R.'s** 100 PIV @ 25p, 400 PIV @ 50p, 800 PIV @ 60p.
- MULLARD PRE-AMP I.C. TAA 435** with data @ 40p.
- 3 PIN PLUG AND SOCKET** like R.S. European type with 2 Metres of Cable at 75p pair.
- 20 PHOTO TRANSISTORS, DARLINGTONS** Assorted Untested @ £1.
- T.V. S.A.W. FILTERS** Untested 3 for 35p.
- 10 MULTI-TURN TRIM POTENTIOMETERS** Assorted @ 60p.
- 100 MULLARD C280 CAPACITORS** @ 57p. Assorted.
- MULLARD ELECTROLYTICS** 2240uf 40v.w. @ 40p, 4500uf 25v.w. @ 40p, 5000uf 10v.w. @ 15p, 6400uf 25v.w. @ 25p.
- TAA 661 F.M. I.C. By Cosem** @ 50p, **RCA CA 3089Q** @ £1
- 50 VARI-CAP DIODES LIKE BA 102** Untested @ 57p.
- 50 2 WATT ZENERS** Untested Assorted for 57p.
- ELECTROLYTICS** 2200uf 100v.w. @ 80p, 3300uf 64v.w. @ 50p.
- SUB-MINIATURE 4.7uf 10v.w. TANTALUMS** @ 6 for 25p.
- MOS PRE-AMPLIFIER I.C. TAA 320** with data @ 35p.
- McMURDO 8 PIN PLUGS** @ 20p, **8 PIN SOCKETS** @ 20p, **COVERS** @ 15p.
- 2 GHz NPN STRIPLINE TRANSISTORS** @ £1 each.
- 20 WATT ZENER DIODES BZY 93 Types** 6.8v, 7.5v, 8.2v, 9.1v, 10v, 11v, 15v, 16v, 18v, 20v, 22v, 27v, 30v. All at 45p each.
- DUAL GATE MOS FET LIKE 40673** @ 33p, 4 for £1.10
- TEN TURN POTENTIOMETERS** 500 ohm, 1K, 2K, 5K, 100K All at £1.50 each.
- ERIE RED CAP .01uf 100v.w. SUB-MINIATURE CAPACITORS** @ 5p.
- BD 187 4 AMP NPN PLASTIC POWER TRANSISTORS** @ 25p, 5 for £1.
- BAW 62 HIGH SPEED DIODES** 12 for 35p.
- OCTAL BASE CATHODEON CRYSTAL OVEN** 6 or 12 volt, with Two HC6U HOLDERS and octal Base @ £1.25
- TRANSFORMERS** 240 Volt Input. Type 1, 24 volt Tapped at 14 volt 1 amp. @ £1.30 (P&P 25p), Type 2, 22-0-22volt 500mA @ £1.60 (P&P 25p), Type 3, 50volt 10amp @ £5.50 (P&P 95p), Type 4, 20volt 2 Amp Twice, 10volt 1 Amp Twice @ £4.50 (P&P 95p) Type 5, 45volt 2 amp, 45volt 500mA @ £3.50 (P&P 85p).
- RAOAR WIDE BAND AMPLIFIER I.C.'s** 10 To 150MHz Untested with data 5 for 57p.
- LIGHT EMITTING DIODES** 2" Dia. Red or Green 15p each.
- CMOS I.C.s** CD 4001 @ 15p, CD 4011 @ 15p, CD 4020 @ 60p, CD 4029 @ 60p, CD 4043 @ 60p.
- FT 241A CRYSTALS** 285 KHz at 20p each.
- MYLAR MINIATURE CAPACITORS** 50v.w., .01uf or 1uf. Both 20p doz.
- MINIATURE ROTARY SWITCHES** 2 Pole 4 way @ 20p, 1 Pole 10 way 2 Bank @ 40p

Please add 20p for post and packing unless otherwise stated, on U.K. orders under £2 Overseas orders at cost

J. BIRKETT

Radio Component Suppliers, 13 The Strait, Lincoln.

GREAT AUTUMN SALE

High Ripple Current Electrolytics . . .
YOU CAN'T MISS THESE

Sprague Powerlytic (Screwed Conns) 33,000µ F 40vdc	£2.00 inc.
Sprague Powerlytic (Screwed Conns) 3,000µ F 100vdc	£1.20 inc.
Plessey Relialytic (Screwed Conns) 15,000µ F 63vdc	£1.80 inc.
Filmcap (Screwed Conns) 15,000µ F 40vdc	£1.50 inc.

Tag Electrolytics*
4,700/40v 60p 100/150v 40p. 33/450v & 15/450v 40p

HIGH VOLTAGE POLYESTERS*

0.1µ F / 1000vdc	5 for £1.00
0.047µ F / 1000vdc	5 for 60p
0.1µ F / 600vdc	5 for 50p
0.047 / 25v disc Ceramics	£2.00 for 100
1µ F / 400vdc Polyester Blocks Radial Leads	10 for 60p

Resistors*

10K 1/2 watt by ITT	200 for £1.00
390R 2 1/2 watt	100 for £1.00
Tantalum Beads* 1µ F/35v	10 for 75p
1µ F/50v	10 for £1.00

Semiconductors*

10a / 50v Bridges	£1.50
18a / 50v Diodes Type 1N1191	5 for £1.00
Opto Isolators Type OPT601 6 pin D.I.L	2 for £1.50

Meters*

Sangamo Weston 60mm sq. 60.0-60mA	£3.00
Taylor 1/2 x 3 500µ A calibrated in Degrees Tilt	£3.50

The following items are not in the Sale

Mk. 2 Metal Locator Kit	£19.60 inc. VAT and P&P
Apollo Logic Tester	£11.75 inc. VAT and P&P
S.R.B. Miniature Soldering Iron 16/18w	£3.75 inc. V.A.T. P&P

*Please include 35p P&P on orders for goods where P&P is not included. All prices include V.A.T.

R.F. EQUIPMENT SPARES LTD.

3 Lacy Close, Wimborne, Dorset BH21 1PY

Please note that our stores at Poole Road Works are open to personal shoppers on Friday afternoons and all day Saturday.

eat your heart out colgate

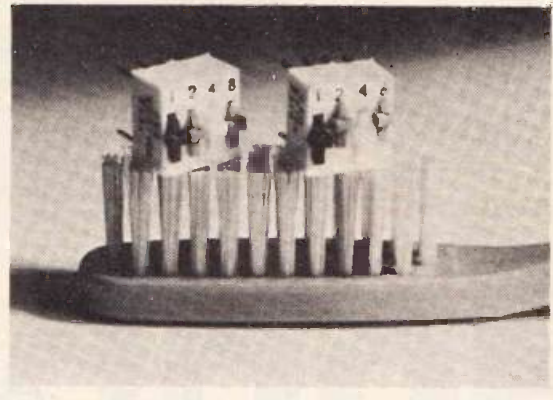

One might question the wisdom of a picture like this, bristling as it is with cunning. At least it's an excuse to brush up on DIL switches. These are made by ERG Components and can switch at up to 10 VA. Fitting a normal DIL format they are numbered in a standard BCD format, and can be very useful in any digital circuitry. Home constructors never seem to make much use of these components for reasons best known to themselves. ERG Components, Luton Road, Dunstable, Bedfordshire.

foiled again

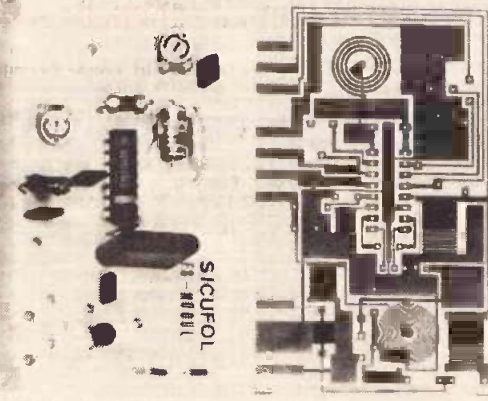

These structures made of chrome-nickel and copper represent an integrated passive circuit with capacitors, coils and resistors, the carrier being a plastic foil. The rectangular, spiral and meandrous shapes largely determine the capacitances, inductances and resistances. Using the name "Sicufol" (Siemens copper foil) Siemens is now offering modules for television sets as the first wares in this new technology.

Resistances up to 300R can be fabricated directly, capacitance to 150pF/cm² and inductances up to 10μH. By meandering the track back and forth, an increase of up to 3800 per given area is possible.

The carrier foil is a kind of Teflon so you shouldn't be stuck for ideas.

ooops

Please note that the prices shown on the Gould Advance Ad on Page 14 of the October issue were incorrect. The correct prices are shown on page 14 of this issue. We apologise to Gould Advance and our readers for any inconvenience caused.

Table containing various electronic components and their prices, including sections for TTLs by TEXAS, TRANSISTORS, DIODES, and others.

On October 13th a brand new magazine is launched in the electronics field. It is written and produced by ETI staff and aimed at the newcomer to electronics — not necessarily young people.

We did think of doing an ad which would tell you about the contents in minute detail but instead we have decided to appeal to your curiosity. We don't ask you to buy it; it may be of no interest to you but we hope that some ETI readers at least will pick up a copy and thumb through it. Please put it back neatly if you don't want to buy: the next person may be more interested.

Hobby Electronics

No. 1 will carry a cover date of November and will be available at newsagents on October 13th. 40p.

QUALITY COMPONENTS BY RETURN

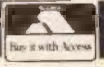

Linear Circuits by RCA, National etc.		TTL from National, Texas, ITT etc.		1702A		420p		MC6800		950p	
709 DIL14	25p	LM392N	105p	7400	12p	2102 (450nS)	90p	MC6810	310p		
741 DIL8	22p	LM1303	110p	7401	12p	2107	35p	MC6820	425p		
741 DIL14	35p	LM3909	50p	7402	12p	2708	75p	MC6850	850p		
747C DIL14	50p	LM3909	80p	7403	12p	AY5-1013	380p	8080A	595p		
749C DIL8	30p	MC1310P	150p	7404	13p						
CA3011	80p	MC1312P	160p	7405	13p						
CA3013	130p	MC1314P	300p	7406	24p						
CA3018	80p	MC1315P	520p	7407	24p						
CA3020	160p	MC1330	100p	7408	14p						
CA3028	125p	MC1458N	35p	7409	14p						
CA3035	140p	MC1496N	60p	7410	12p						
CA3036	170p	NE555	25p	7411	19p						
CA3042	170p	NE556	60p	7412	17p						
CA3043	180p	NE560	300p	7413	25p						
CA3046	55p	NE561B	350p	7414	46p						
CA3052	150p	NE562B	350p	7415	22p						
CA3054	115p	NE565A	120p	7416	24p						
CA3075	180p	NE566V	150p	7417	24p						
CA3080	70p	NE567V	170p	7420	12p						
CA3081	125p	SN76003N	200p	7421	22p						
CA3089	180p	SN76013N	140p	7422	18p						
CA3090	400p	SN76023N	180p	7423	22p						
CA3123	150p	SN76033N	200p	7425	22p						
CA3130	90p	TA6621A	215p	7426	24p						
CA3140E	70p	TBA120S	65p	7427	24p						
LM3000H	130p	TBA540	200p	7428	28p						
LM301AN	28p	TBA641	240p	7430	12p						
LM304H	70p	TBA800	70p	7432	22p						
LM308N	85p	TBA920	320p	7433	32p						
LM318N	125p	TCA2705Q	200p	7437	22p						
LM324N	50p	TDA1002	450p	7438	22p						
LM339	50p	TDA1022	570p	7440	13p						
LM380N	75p	TDA2020	320p	7441	52p						
LM381N	105p	ZN414	75p	7442	43p						
				7443	75p						
				7444	75p						
				7445	70p						
				7446	55p						
				7447	55p						
				7448	50p						
				7450	14p						
				7451	14p						
				7452	13p						
				7454	14p						
				7456	14p						
				7470	22p						
				7472	24p						
				7473	25p						
				7474	25p						
				7475	32p						
				7476	20p						
				7483	80p						
				7485	70p						
				7486	24p						
				7489	14p						
				7490	32p						
				7491	35p						
				7492	35p						
				7493	34p						
				7494	80p						

Carbon Film Resistors
High stability, low noise, 0.25W 5% E12 series from 4.7 ohms to 10 Megohms. Any selection each 100+ 1000+ 5000+ 1p 0.8p 0.8p 0.75p
Special development pack of 10 of each value 4.7 ohms to 1 Megohm, a total of 650 resistors **£5.70**

Potentiometers
Carbon track Log and Linear values
5K-2M2 single gang **20p**
5K-2M2 single gang switched **50p**
5K-2M2 dual gang stereo **75p**

Preset Potentiometers
Subminiature type available in horizontal or vertical mounting.
Q: 1W rating, 100 ohms to 2M **6p each**
Special development of 5 of each value from 100 ohms to 2M, a total of 70 presets (please state vertical or horizontal) **£3.95**

Ceramic Capacitors
Miniature plate type 50V PC mounting. Available from 22pF to 1000pF in E12 series and 1500pF to 0.047uF in E6 series **2p each**

Polyester Capacitors
Mullard C280 series 250V PC mounting.
0.01, 0.015, 0.022, 0.033, 0.047, 0.068, 0.1, 5p; 0.15, 0.22, 7p; 0.33, 0.47, 10p; 0.88, 14p; 1.0, 17p; 2.2uF, 28p each.
Special development pack of 5 of each value **£6.20**

Tantalum Capacitors
0.1, 0.15, 0.22, 0.33, 0.47, 0.68, 1.0, 2.2 @ 35V **9p**
4.7 @ 25V, 6.8 and 10 @ 25V **13p**
22 @ 15V, 47 @ 6V, 68 @ 3V, 100 @ 3V **16p**
Development pack 5 of each value **£8.30**

Optoelectronics
LEDs

0.125 in	Red	Green	Yellow
0.2 in	9p	15p	18p

Displays DL707 90p DL704 90p

DIL Sockets 8 pin 11p 14 pin 12p 16 pin 13p 24 pin 30p

Quantity discount on any mix. TTL, CMOS and Linear Circuits 25+ 10%; 100+ 15%. All orders despatched by return. Prices VAT inclusive. Please add 30p for carriage. All components guaranteed brand new and full specification from leading manufacturers. Callers most welcome at our premises 8.30am to 6pm Monday to Saturday. All prices valid to April 30, 1979. Send 12p stamp for our new illustrated catalogue.

Regulators

7824	60p	7912	80p	79L12	70p
7805	60p	78L05	30p	7915	70p
78L12	60p	78L12	30p	7918	70p
7815	60p	78L15	30p	7824	80p
7818	60p	7905	80p	79L05	70p

C. N. STEVENSON (E2) 236 High Street, Bromley, Kent BR1 1PQ. Tel: 01-464 2951/5770

AUDIO AND TEST EQUIPMENT CENTRE

MICROCOMPUTERS LEVEL I AND II TRS80 IN STOCK

ALL PRICES INCLUDE VAT

Only regular stocks listed — other makes and models available.

Telephone your order with Access and Barclaycards



4D10A



DM235



TE20D

LONDON'S TEST GEAR CENTRE
OPEN 6 DAYS A WEEK 9 am-6 pm

SCOPES — IN STOCK

3" 5MHz single beam	92.50
4B10, 5MHz single beam (4)	107.00
MS15, 15MHz Batt/mains, portable	286.00
MS215, Dual trace version of above	380.00
Super 6/4S6 Scope x 6MHz single beam	149.00
Super 10/4D10A, Scope x 10MHz Dual trace	229.00
4D25 Scope x 25MHz Dual trace	338.00

LOW COST
New 5MHz mains portable scope now in stock
£92.50

PROBES x 1 x 10, 14, 50 x 10 9.95 x 1 7.95 For 4S6/4D10A/4D25

LED AND LCD DIGITAL MULTIMETERS

DM235 Sinclair portable 3 1/2 digit LED	52.90
PDM35 Sinclair Pocket 3 1/2 digit LED (30Kv Probes 18.28, Mains adaptors 3.75, DM235 carriage 8.95)	29.95
LM3A 3 Digit Miniature with large LED displays	96.00
LM3.5A 3 1/2 Digit Recharge Batts and charger 17 ranges	106.00
LM40A 4 Digit	210.00
LM300 3-digit Miniature battery operated 17 ranges	87.00
LM350 3 1/2-digit with LCD displays 1 1/2 A/mV resolution	96.00



LM3.5A

MULTI-METERS — GENERAL PURPOSE & ELECTRONIC

Multi-Range Instruments featuring AC/DC volts, DC current, Resistance Ranges all with mirror scales except T1/IT1-2/T12/TM3A (TM3 AC volts only) some with AC current etc.

TM11 incredible 120 Range Electronic Multi-meter	136.00
TM3B AC Micro voltmeter 3MHz > 4 Megohm	130.00
TM8B Broadband voltmeter 300KHz-400MHz	196.00
360TR 100k/volt 23 Range (plus transistor checker) Large scale	35.50
PROE 20k/volt 26 Range Large scale	32.00
7081 50k/volt 36 Range Multi-meter	23.50
Tmk500 30k/volt 22 Range Multi-meter (plus Continuity Buzzer)	21.00
880R 20k/volt 52 Range Pocket Multi-meter	34.50
7200 20k/volt 22 Range Double Multi-meter	17.95
Micro80 20k/volt 26 Range Pocket Multi-meter	17.90
IT1-2 20k/volt 16 Range Popular Multi-meter	11.95
LT22 20k/volt 19 Range Pocket Multi-meter with carry case	14.50
T12 5k/volt 13 Range Pocket Multi-meter	8.95
LT101 1k/volt 2 Range Pocket Multi-meter	7.50
EM2000 FET IC VOM 20 Ranges 10 Meg Input	55.00
K200 FET VOM 38 Ranges	77.00
GT101, 20K/Volt 23 Ranges/Transistor Checker/Continuity Checker	17.95

AVO 8s and a large range of replacement test leads in stock

GENERAL EQUIPMENT

TE7 Signal Tracer	8.95
SWR50 SWR/Power Meter	19.50
LP30 30MHz Low Pass Filter	4.95
CX3A 150Watt 3-way AE Switch	7.50
DC25KV 100 Meg HV Probe	11.95
9 Value CAP Subs Box	2.95
DR510 36 Value Resis. Box	3.90
FX2000 Xtal Marker	11.95
TR1000 Transistor Checker in/out circuit	11.95
MD63 Signal Injector	7.50
TT169 In Circuit TR Checker	49.95
LB1 Transistor/Diode Checker	21.50
3101 Clamp Meter 0/1 K ohm. 0/150/300/600 AC Volts 0/300 Amp	32.95
C3042 SWR & FS Meter	9.95
MS319 2x100 Watt Audio Watt Meter	17.50
500V Megohmmeter 500 Megohms	48.00
1000V Megohmmeter 1000 Megohms	55.00
2V Amp Variable Transformer	19.95
5 Amp Variable Transformer	33.00
10 Amp Variable Transformer	46.00

MICROPHONES, SPEAKERS AND COMPONENTS LARGE RANGE IN STOCK



TM11



TMK500



FM7 7 Digit 60MHz Rock. Batt. Freq. counter 156.00
SCS 512MHz Prescaler for above 81.00
MAX100 100 MHz 8 digit batt. operated counter 63.75



TM3

CALL IN AND SEE FOR YOURSELF

PRICES CORRECT AT SEPT. 8th. E.&D

AUDIO ELECTRONICS

301 EDGWARE RD., LONDON W2 1BN
01-724-3564. OPEN 9-6, MON-SAT.

ALSO AT 248 TOTTENHAM COURT ROAD, W. 1.

FREE CATALOGUE

SEND STAMPED 12" x 6" UK ADDRESS ENVELOPE (MIN 9" x 4") FOR YOUR COPY NOW

WANTED



Editorial Assistant for ETI and Hobby Electronics

If YOU have a genuine interest in electronics and project building and an above-average ability to express yourself in writing, you could be the person we're looking for. We are being serious.

We are looking for someone to join the editorial team and reckon that an enthusiastic reader is likely to be the type to join us. Not an uncritical reader — we want to continue to improve. The work will entail dealing with articles and news — licking them into shape — and making them better than anyone else's articles and news. The applicant will work on both ETI and our new sister publication Hobby Electronics. Readers employed in journalism at the moment will be considered but we are not primarily looking for someone with magazine experience.

We are flexible about age and experience but imagine that the person who gets the job will be between 21 and 28. Salary will depend upon age and experience but will be in the range £3,700 to £4,100, possibly more for someone with exceptional qualifications.

Experience has told us that people who read ads like this think a) that it doesn't apply to them b) that their own knowledge is far too limited or c) that ads of this type are only put in because we have to fill half a page. None of these is true.

Apply in writing to:
Halvor Moorshead,
Editor,
Electronics Today International,
25-27 Oxford Street,
London W1R 1RF.

Applications should reach us as soon as possible with C.V. Prospective applicants may telephone the Editor for further details but this must be followed by written application.

Gould Advance Instruments— Professional quality at a realistic price.

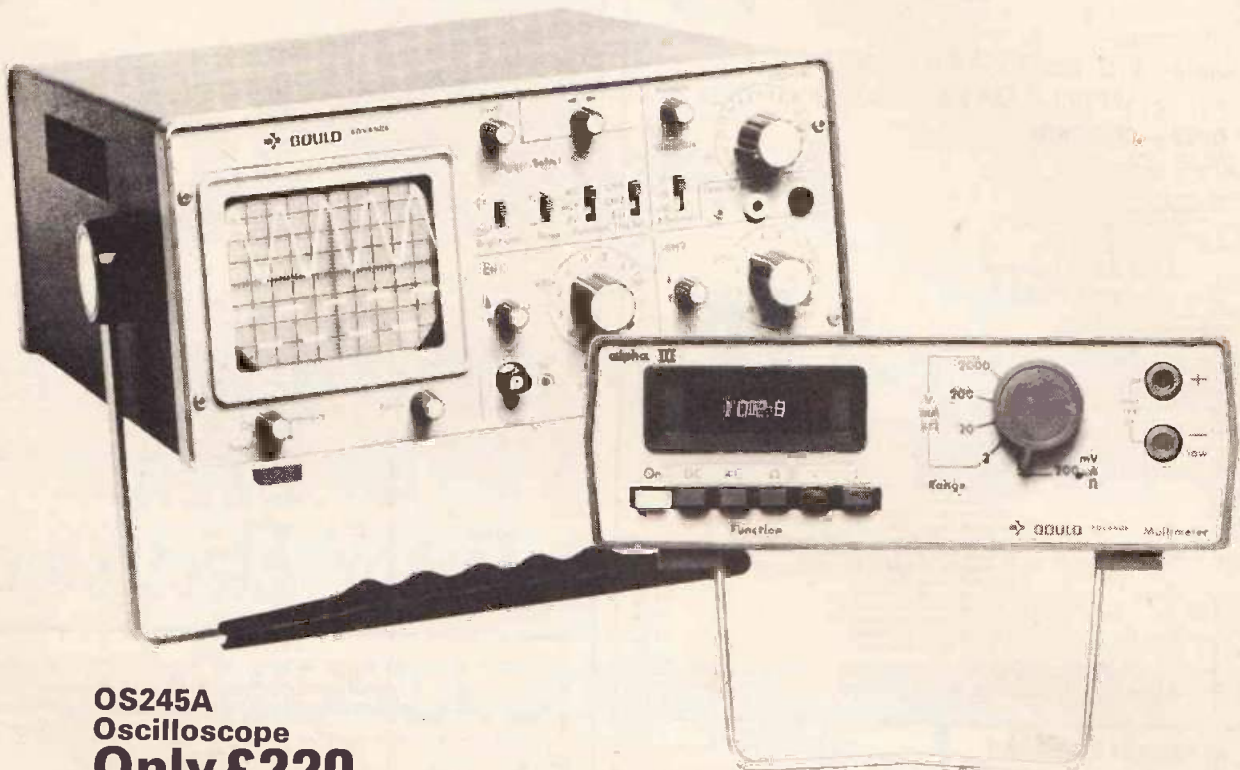

**OS245A
Oscilloscope
Only £220** (excluding VAT)

**Alpha III Digital
Multimeter Only £99** (excluding VAT)

OS245A Oscilloscope

Fault-finding, circuit testing or servicing — an oscilloscope is indispensable. It saves time, prevents costly mistakes, and enables you to tackle bigger, better projects.

Now, Gould Advance offer you this professional-quality, dual-trace instrument, at a price which brings it within reach of the amateur enthusiast.

Just look at these great Gould Advance features — then compare the OS245A for value!

- *DC-10MHz bandwidth
- *Dual trace
- *Clear controls, simple operation
- *Fully guaranteed for 2 years
- *5mV/div. sensitivity
- *Time-base speeds to 100 ns/div.
- *4" CRT with 8 × 10 div.

Gould Instruments Division,
Roebuck Road, Hainault, Essex IG6 3UE.
Telephone: 01-500 1000 Telex: 263785.
Registered Number 263834 England.

Alpha III Digital Multimeter

With a choice of 25 ranges and basic accuracy of $\pm 0.2\%$, the Alpha III is a professional's multimeter, yet it is versatile enough to cover every amateur application.

And although it is offered at such a modest price, it shares the advanced design features of the more expensive Gould Advance instruments — in particular, the purpose-built chip, incorporating all analogue and digital circuitry.

- *2,000 scale length (100mV resolution)
- *Tough, attractive moulded case
- *Bright red LED display
- *25 ranges
- *Fully guaranteed for 2 years

 **GOULD**

**TO Bob Wheeler, Gould Instruments Division,
Roebuck Road, HAINAULT, Essex IG6 3UE.**

PLEASE SEND ME —

AN OS245A OSCILLOSCOPE at £240.84 (inc. p&p and VAT) *

AN Alpha III DIGITAL MULTIMETER at £110.16 (inc. p&p and VAT) *

I enclose
 CHEQUE * POSTAL ORDER * CASH *

for the amount of £ _____

 Or please charge my Access *
 Barclaycard *

Account for the amount of £ _____

MY ACCOUNT NUMBER IS

Signature _____ (I am over 18)

Surname _____

Initials _____ (Mr/Mrs/Miss)

Address _____

Postal Code _____

*Tick which appropriate ET4
Block Capitals Please

Note: This offer applies to the U.K. and Ireland only.

ETIPRINTS

ETIPRINTS are a fast new aid for producing high quality printed circuit boards. Each ETIPRINTS sheet contains a set of etch resistant rub down transfers of the printed circuit board designs for several of our projects. ETIPRINTS are made from our original artwork ensuring a neat and accurate board. We thought ETIPRINTS were such a good idea that we have patented the system (patent numbers 1445171 and 1445172).

HOW IT WORKS



Lay down the ETIPRINT and rub over with a soft pencil until the pattern is transferred to the board. Peel off the backing sheet carefully making sure that the resist has transferred. If you've been a bit careless there's even a 'repair kit' on the sheet to correct any breaks!

BUYLINES

ORDER TODAY

Send a cheque or P.O. (payable to ETI Magazine) to —

ETI PRINT
ETI MAGAZINE,
25/27 OXFORD STREET, LONDON W1R 1RF.

75p inc p&p

PARTS LIST

001	3 Channel Tone Control	Oct 77
	Spirit Level	Oct 77
	Clock A	Nov 77
	Digital Thermometer	Oct 77
	Skeet Game	Nov 77
	Componder	Nov 77
002	House Alarm	Jan 78
	Rev Monitor	Dec 77
	Clock B	Dec 77
003	Race Track Game	Jan 78
	Hammer Throw	Jan 78
	Freezer Alarm	Dec 77
004	Metal Locator Mk II	Feb 78
	Ultrasonic Tx / Rx	Feb 78
	5 Watt Stereo Amp (modified)	
	Metronome	Jan 77
	Shutter Time	Feb 78
		Feb 78
005	Op-Amp Supply	
	Frequency Shifter	Mar 78
	LCD Panelmeter	
	Light Dimmer (3 times)	
006	CMOS Switched	
	Preamp	
	From Experimenters	"Electronics
	P.S.U.	Tomorrow"
	555 Boards (twice)	
007	Star Trek Radio	May 78
	CD Ignition	May 78
	CCD Phaser	May 78
	White Line Follower	April 78
008	Tank Battle	
	Helping Hand	May 78
009	AM / FM Radio	
	Bridge Oscillator	June 78
	CMOS Stars & Dots	
010	Bench Amplifier	
	Freezer Alarm	
	Marker Generator	Project
	LED Dice	Book
	Watchdog (2 PCBs)	Six
	Stars & Dots PSU	
011	Noise Generator	
	General Preamp	
	Flash Trigger	Project
	Componder	Book
	Active Crossover	Six
	(2 PCBs)	
012	Disco Lightshow	
	Stereo Simulator	Project
	Digital Thermometer	Book
		Six
013	Amplifier Module	
	Amplifier PSU	Project
	Equaliser	Book
	Equaliser PSU	Six
014	Skeet Game	
	Sweep Oscillator	Project
	Burglar Alarm	Book
	GSR Monitor	Six
015	UFO Detector	July 78
	Torch Finder (twice)	July 78
	Etiwet (twice)	Aug 78
016	Stac Timer	
	Khatch Gen	Sept 78
	Wheel of Fortune	
017	Complex Sound Gen	
	Tele Bell Extender	
	Power Bulge	Oct 78
018	RF Power Meter	Oct 78
	Proximity Switch	Oct 78
	Audio Oscillator (2)	Nov 78

ONE BOARD HOME COMPUTER

ETI, Transam and Mike Hughes, who designed the system, present the Triton — a one board computer that includes all the features expected in a machine providing the basis of a really powerful home system.

ADD A STANDARD domestic TV set and a cassette recorder to the TRITON and you have a complete home computing system that is equal to, indeed in some areas superior to, many of the commercial ready built systems now on the market.

The TRITON has been designed on a single board, which means that construction should not pose any problems providing an adequate standard of soldering is maintained throughout. The case, designed specifically for the TRITON, means that the finished unit can safely and attractively be housed. In use, with the TV set on top of the case, the TRITON will be easy and convenient to operate.

The TRITON is based on the 8080

MPU, a device which has proven itself over a number of years. This MPU has a vast amount of software available for it and the TRITON's 1K monitor system allows for easy entry and subsequent modification of such material.

The 2K TINY BASIC that is also resident in the TRITON, allows this popular, easy to learn, language to be used in conjunction with the TRITON's versatile graphic character set and unique VDU function to develop everything from games to education programs quickly and easily.

The TRITON has space for 3K of user RAM on board but the machine has been designed in order to make expansion a simple matter. All the

signals necessary to add further memory, I/O devices etc. are brought out to an edge connector at the back of the board.

It is essential to use a top quality double sided plated through board for the project. Unlike many projects the PCB is likely to be the most expensive single item you have to invest in but it is this component which brings the whole project into scope for the average constructor with no significant theoretical knowledge.

The board has been designed to keep all the most intricate wiring on the top side — in particular the connections that run between IC pins. The latter are the most vulnerable to a heavy hand on the soldering iron but this is not saying that you can afford any carelessness underneath! Use the smallest soldering iron you can lay your hands on and the bit must, certainly, be no greater than 3/32in diameter. As stated, **all** soldering operations should be carried out on the underside of the board; the through hole plating will route all necessary connections to the topside.

Wherever possible it is worth trying to re-inforce the through hole plating by getting molten solder to creep through the hole by capillary action, therefore hold the soldering iron in place long enough for the heat to flow through the hole and take the solder with it. A couple of seconds longer than your usual soldering time should suffice. You will notice that on the underside of the board there are hundreds of IC pin lands that do not appear to be connected to anything. These lands **must** be soldered in **all** positions because nearly all of them go somewhere on the top side!

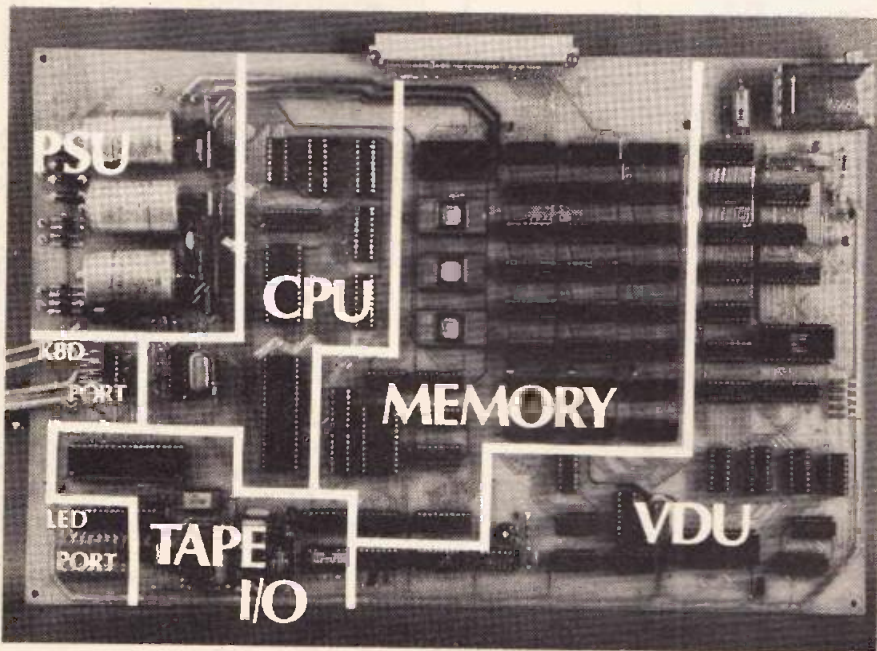

The single board that carries all of the Triton's circuitry with the areas concerned with various parts of the system indicated.

See John Coll's comments on the Triton in *Computing Today*



Transam Components Ltd of 12 Chapel St, will be sole suppliers of the Triton and will also supply individual parts for the computer.

Construction Commences

Take your time with the soldering — even at a slow pace you can complete this project in a couple of days — because it is very easy to miss a connection or produce a dry joint. We recommend that you insert one component at a time and solder it in completely before moving on to the next; a visual check of each joint is essential and if you have any doubt don't be afraid to use a magnifying glass. A few seconds wasted doing this can save hours — if not days — trying to find a single missed connection!

All the holes on the board have been pre-drilled to the correct diameters but in the event of you having a device which will not quite go through the hole do not UNDER ANY CIRCUMSTANCES attempt to drill out to size — you will ruin the through hole plating! The ONLY holes you may drill out are the fixing holes for the board and the mounting holes for the extender socket. If you have a stubborn component try scraping down the diameter of its lead with a sharp knife or use a needle file to reduce its dimensions slightly. Probably the only offender you will find in this respect is the modulator which has rather large fixing lugs that sport a taper. These

might vary a little from device to device.

We recommend the use of sockets for all the integrated circuits as it is virtually impossible to remove ICs from a double sided THP board.

Start construction by soldering in all the DIL sockets while the board is flat — it makes life much easier — and then insert all resistors and diodes. Next insert the nine board pins which connect to the transformer and IC1 (the off board voltage regulator). Proceed to solder in the in line strip sockets and the extender socket. When the latter is firmly soldered you should carefully drill out the board mounting holes with a drill using the connector's holes as a guide and then bolt it firmly into place.

Switched On System

Insert the three transistors for the tape I/O. Proceed then to the capacitors and LEDs. Leave the three large smoothing capacitors till last and be very careful that you insert the LEDs the right way round. You will have to look very careful at the solid tantalum capacitors to find their polarity. You should then insert, and solder in the three preset potentiometers.

Before progressing further check

the polarity of all the diodes and electrolytic capacitors you have inserted.

You can now insert, and solder in the three crystals making sure you have them in the correct positions. The crystals have their frequencies stamped on them (usually in kilohertz).

Continue with construction by putting in the modulator and the two on board regulators. Make sure you have the regulators in the right position. Ensure that you insert them the right way round. The metal fin should be on the face of them furthest away from the main smoothing capacitors.

Temporarily mount IC1 on its heatsink and run flying leads to the three pins allocated to it.

The great moment is close at hand but before inserting any integrated circuits give the power supply a dry run. Connect up the remaining six board pins to their corresponding terminals of the transformer and apply power. Use a voltmeter to see that you have the correct voltage rails present. You should get +5 V and +12 V at the output pins of ICs 1 and 2 respectively and -12 V at the output of IC3. You should read -5 V

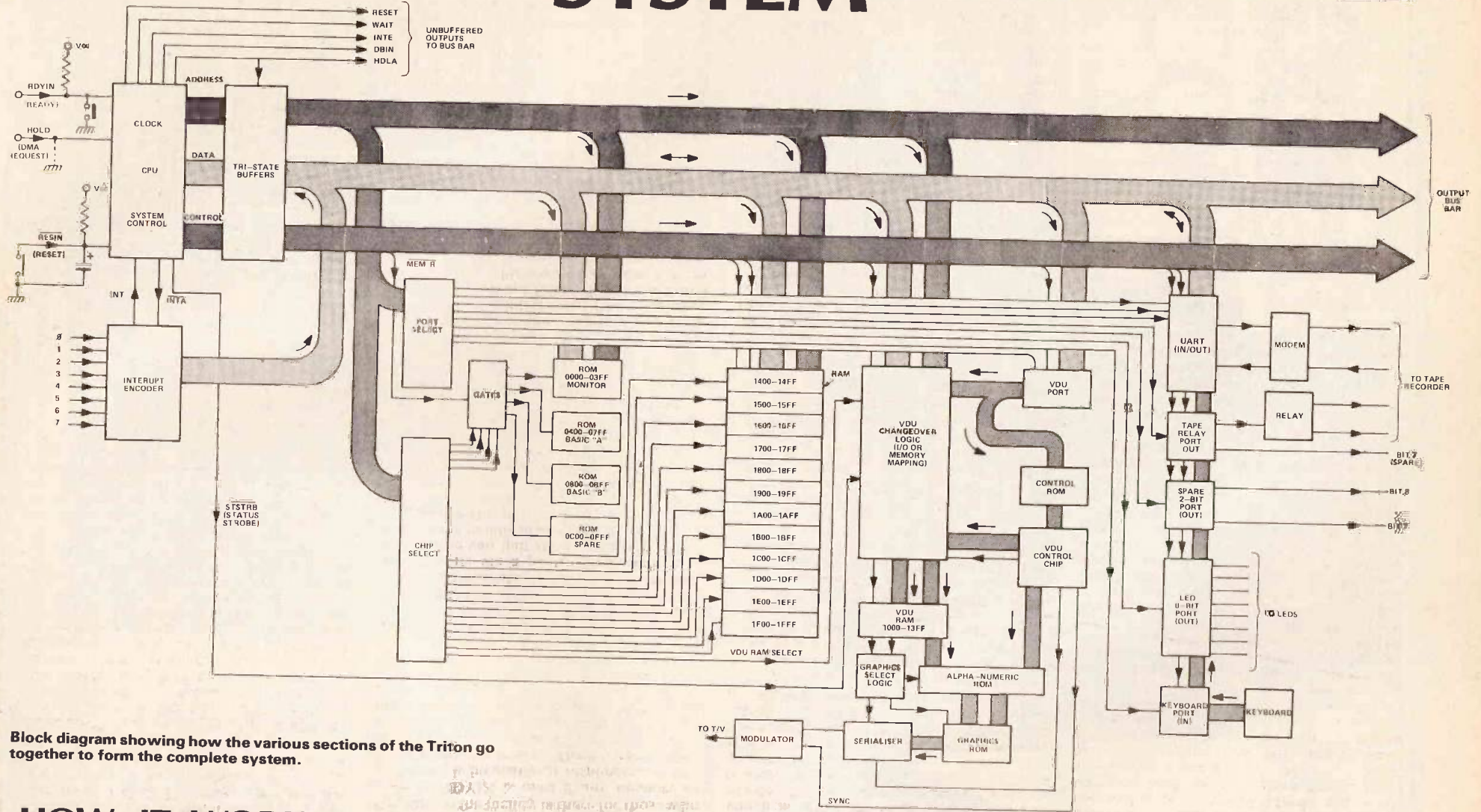

Block diagram showing how the various sections of the Triton go together to form the complete system.

HOW IT WORKS

The heart of the system is the microprocessor (MPU) itself — the faithful old 8080A. This MPU has a very simple to understand instruction set which is remarkably versatile for those who like to dabble in work at machine code level and because of its years of experience there is a great variety of software freely available to use with it. In addition it is one of the cheapest MPUs on the market.

The MPU will sequence through a list of

These eight lines are decoded to activate any one of 256 possible external devices through what are called PORTS.

Before moving on from the heart of the system it is worth mentioning some of the single lines depicted on the illustration. When the computer is initially switched on it is necessary to give it the right instruction to start with so that it can sequence on from there to complete the program in a sane manner. For this reason it is usual to have the

operation on the VDU screen and to do a re-initialisation without clearing all the memory (which would otherwise happen if one pressed the reset button). There are five remaining lines one of which is brought out to a spare push button on the front panel and the rest are piped down the multiway socket along with the busbars. The interrupt request lines have to be encoded and formatted into an eight bit data byte. When this is done the interrupt encoder tells the CPU with the INT

decoding the least significant eight bits of the address bus) through the Port Select logic and issues a I/O control signal which data from the keyboard be placed on the data busbar. Working in the opposite direction, the Output Port driving a bank of eight on board LEDs is a set of eight latches which catch and hold whatever data is on the busbar when they receive a coincident pair of signals from the port selector and the I/O signals from the port selector and the I/O

instructions hold in memory as 8 bit bytes and on receipt of each instruction will carry out an operation which ranges from getting another byte of data from somewhere else in memory to carrying out simple logical or arithmetical operations on that data. It is not within the scope of this article to cover the inner workings of the MPU itself or, for that matter, to explain every operation that the 8080 can offer.

As it operates sequentially the MPU needs clock. In this case the master frequency is 7.20MHz which is divided down to clock the MPU every 1.25µs. This time is the duration of a microcycle and it takes from 4 to 11 microcycles for the MPU to complete an instruction.

The MPU itself has quite a large number of lines leading to it. The 8 data lines are in the form of a bi-directional busbar (i.e. can carry data to or from the MPU). To cut down on the number of wires coming from the MPU the data busbar serves a secondary purpose. It carries what is called "STATUS" information at a certain point in time within an instruction cycle. This status information is in the form of an 8 bit byte and is decoded by the System Controller. When decoded the Status byte feeds one of 5 lines with a logical "0" which tells the rest of the system what sort of instruction the MPU is executing during that cycle. These lines are grouped together to form the CONTROL BUSBAR and are designated INTA (meaning that the computer has just been interrupted by an external "Interrupt Request"), MEMR (reading data from a memory location), MEMW (writing — or storing — data into an internal memory location), I70R (inputting data from an external source — such as a keyboard or a tape system) and I70W (outputting data to an external destination such as a VDU or a tape system).

The 16 lines which carry a 2 byte WORD which is used to ADDRESS a specific byte of memory form the uni-directional ADDRESS BUSBAR. Using 16 binary lines one can therefore address up to 65,536 (decimal) memory locations. We have limited the capacity of the TRITON to 8K of memory but the address busbar (in common with the data and control busses) are buffered and can be fed to the outside world through a multiway connector thus allowing easy expansion to maximum capacity with add on boards.

The address bus also serves a duplicity of roles depending on whether the instruction cycle is a memory addressing or an I/O addressing cycle. As already stated all sixteen lines are used to address memory locations but during an I/O read or write cycle the CPU is limited to providing address data on the eight least significant address lines.

first instruction at address location zero. We can reset the MPU by depressing a push button or at switch on by the POWER ON RESET.

Those that want to can use the line marked HOLD for applications involving DMA (Direct Memory Access). Basically this means that by making this line go to logic "1" one can isolate the internal CPU from all three busbars (using the tristate facility of the buffers) and allow an external device to do what it will with the internal memory. We have strapped this line to "0" with a removable link so the facility is there for those who want it. RDYIN is used if any memory of peripheral is incapable of responding as fast as the computer desires. The external device can make this line go to "0" for any period of time (usually set by a monostable) and when this happens the MPU goes into a WAIT state and it does just that. It simply stops operating as long as this line is low and when the RDYIN signal is removed it carries on as if nothing had happened. The only thing it does do during this time is issue a signal to the outside world called WAIT. You can see the WAIT line designated as one of the unbuffered outputs. In addition by connecting RDYIN via a push button switch to ground one can halt the computer momentarily in the middle of any operation. Facility for bringing this out to a push button is not made on the board but it is a simple matter to pick up the right point on the top side and take it via a single wire to the front panel — see the circuit diagram of this section.

The RESET output goes high momentarily when the reset button is pressed and can be used to carry a synchronous reset on external equipment; the HDLA output tells the outside world that the computer has gone into a HOLD (or DMA) state — if anyone takes the HOLD Line high; the INTE Line tells the outside world that the computer is permitting itself to be interrupted (the mnemonic stands for Interrupt Enabled) and the DBIN line indicates which way the computer expects data to be flowing on the bi-directional data bus. It goes high when the CPU is expecting data to flow INTO it.

We are using the STSTRB (STATUS STROBE) signal — to synchronise the memory mapping of the VDU — more is said about this in the relevant section.

As already implied the 8080 will allow itself to be interrupted in mid program provided that the program sets the Interrupt Enable flag. There is facility for eight possible interrupts but only seven can really be used on this machine (Interrupt 0 is redundant as it duplicates RESET). An interrupt is entered into the machine on a single interrupt request line. Of the seven usable lines we are using two within the machine to do a clearing

signal that interrupt has been received. When the CPU is ready to be interrupted it issues an Interrupt Acknowledge signal INTA which is used to place the encoded byte on to the data bus. This byte enters the MPU and directs the computer to operate the desired subroutine. At the end of the routine the computer reverts to the main program continuing at the point where it was interrupted.

The memory of TRITON is split into three types on the main board. There are locations for up to 4K of Read Only Memory (ROM) which is split between four 2708 Erasable ROMs. These occupy address locations 0000H to 0FFFH. The standard TRITON uses the first 1K to hold Monitor and Utility routines necessary to initialise the machine and re-vector interrupts. The next 2K holds a BASIC INTERPRETER and the fourth 1K block is left spare for future expansion.

There is 1K of Random Access Memory dedicated to the VDU. This starts immediately above the ROM area starting at 1000H. Normally this RAM is addressed in synchronism with the VDU line scan by the VDU control circuitry but the CPU can take over addressing under program control (in effect interrupting the VDU). The VDU RAM can only be written into by the computer.

The rest of memory is made up of RAM which is both read and write. This area is used to hold the stacks and tables of the MONITOR and BASIC INTERPRETER (512 bytes) and the main work area starts at 1600H for a further 2½K ending at 1FFFH. This represents the full capacity of the on board memory. There is no reason, however, why further read write memory should not be added externally starting from location 2000H.

The ROM and VDU RAM areas are blocked into units of 1K — to fall into line with the types of integrated circuits used. However, the stack and work area RAMs are laid out in blocks of 256 bytes.

The high order lines of the address busbar are used to decode which block is being addressed — this is done by the Chip Select decoder. Note that the ROM chip selects are gated with the MEMR signal from the Control Bus whereas this control signal and MEMW go straight to the RAM chips. This is because the 2111 Random Access Memory ICs used have internal chip select gating and output enables.

With the exception of the VDU which is "hybrid" the rest of the system is made up from a variety of I/O stages. The most important of the latter is the Keyboard Input. The keyboard data and strobe lines are fed on to the data busbar via tri-state buffers which form the keyboard input port. Only when the computer's software addresses this port (by

help to make the TRITON system more versatile and can be used for test purposes or in specialised development applications. The LEDs themselves could be discarded and the eight lines brought to the outside world as a spare general purpose output port.

By making use of a couple of spare latches on the board it was possible to provide two spare output lines on one port and a spare line on the port which also feeds the tape recorder power control relay.

The UART (Universal Asynchronous Receiver/Transmitter) is the device which converts the eight bit wide parallel data on the busbar to a specially formatted serial stream to feed the tape recorder modulator. It also carries out the complementary function of converting a received serial stream into parallel data bytes. The device operates as if it were two input ports and one output port. One of each sort of port would be obvious for a device which receives and transmits but the requirement for a second input port may not be so obvious. Because the device operates asynchronously from the main computer (it has its own clock operating at 300 baud) it is necessary to make the computer wait from time to time to allow the slower operating UART to complete a transmission cycle. This is indicated by the UART activating a flag which is regularly monitored by the second input port.

The VDU portion of the computer is based on the Thomson-CFS Control chip and operates in a unique manner for this integrated circuit. Not only can one output to the VDU through an output port (in similar manner to using a teletype) but one can use the computer to write data directly into the VDU's memory at extremely high speeds.

A further extension is the way the control chip has been used to handle Graphics. Instead of the usual six bit wide RAM seven bits are used in this VDU application. This way enables the use of the complete set of ASCII codes. 64 extra character codes are therefore available by using those normally associated with lower case "alpha" characters and all the control codes. Within the overall context of the computer some of the control codes serve dual purposes and the VDU control ROM inhibits printing a graphic when a control code is issued for genuine control purposes!

The graphic select logic looks at the two most significant bits of the ASCII code, determines whether or not the symbol is graphic or alpha-numeric, then proceeds to select the standard alpha-numeric ROM or the specially programmed graphics ROM. There is quite a lot of extra logic associated with this operation as well as the Memory Map/I/O changeover but we shall reserve comment on this to the section describing the circuit in detail.

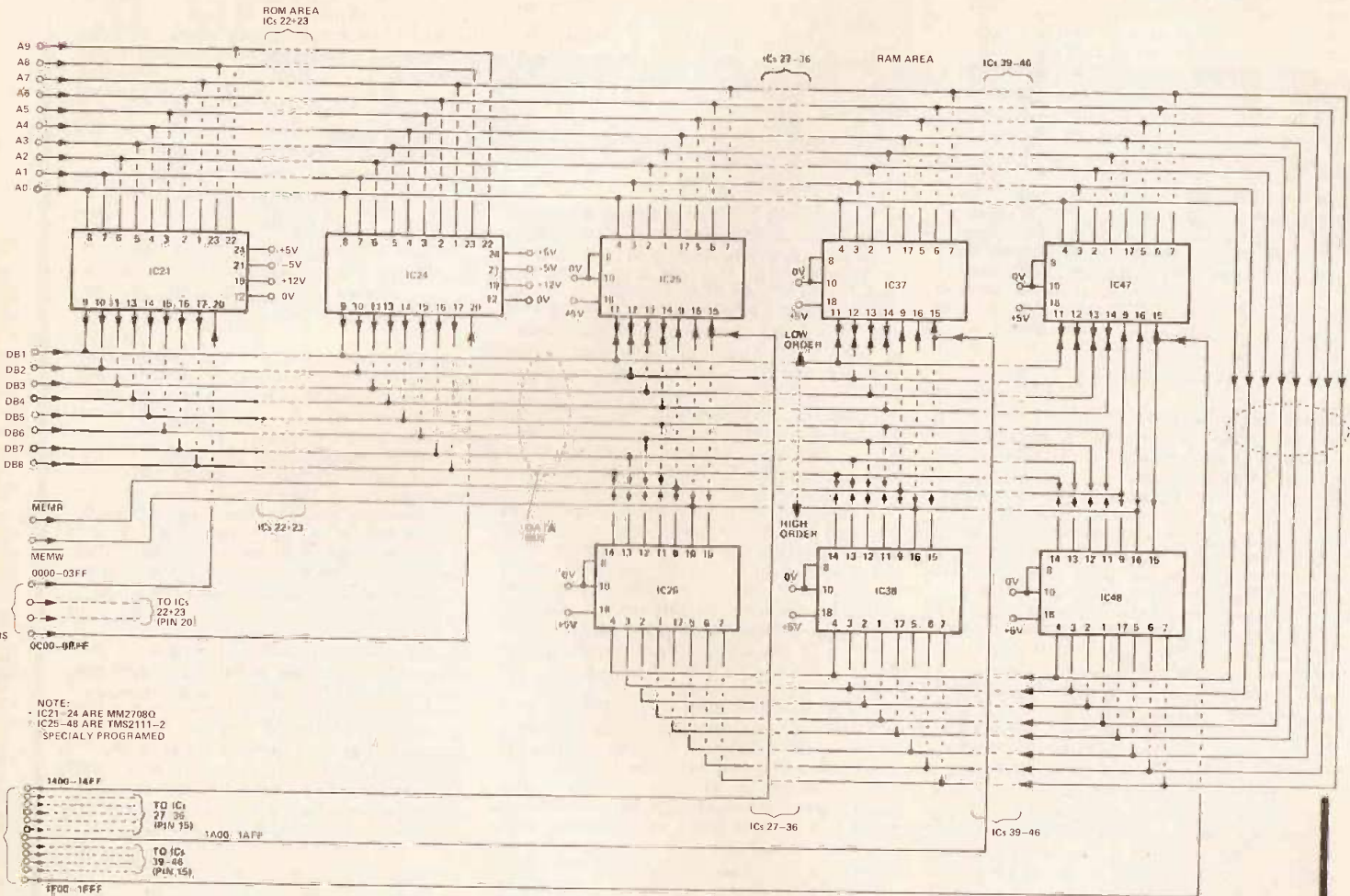

HOW IT WORKS

The circuit diagram of this section has been abbreviated as most of the memory circuitry is a repeat of the same theme. You can clearly see the difference between the ROMs and the Read/Write RAMS. There are four of the former – all 2708s but in the standard machine only three are used immediately. The 2708 is an ultra violet erasable ROM which contains 1,024 (decimal) bytes of memory each being 8 bits wide. To access a specific byte within it you need a 10 bit address and A0 through A9 are used for this purpose. The eight output pins are tri-state which are enabled by a "0" on pin 20 (the chip select input). The respective outputs from each of the ROMs can therefore be commoned together on the data bus. The "Programming Enable" pin (18) is only used when the devices are being programmed and therefore is left disconnected within the system. We use the block select signal gated with MEMR to provide the Chip Select strobe for the ROMs (this is described elsewhere).

The Monitor program is located within IC21 which starts at address location 0000H so that the computer will always go through a firmware initialisation routine when switched on. The Power On Reset ensures that the first instruction the CPU reads will be the one located at 000H BASIC is located within ICs 22 and 23.

The RAM area of memory comprises TMS 2111-2 chips. These each contain 256 locations that are four bits wide. As we need to store eight bit bytes of data two chips are required for each 256 byte block of memory. The odd number designations IC25 to IC47 correspond to the low order nibble of the byte while the respective even numbers (IC26 to IC48) correspond to the high order. Only eight address lines (A0 through A7) are required to uniquely select a byte within this organisation of a chip pair but we need to specify which pair by means of the Chip Select lines (these have been decoded elsewhere in the system).

The 2111s have internal chip select and Read/Write gating so we are able to drive the MEMR and MEMW inputs direct from the control busbar.

Circuit diagram of the ROM and RAM circuitry. Note that in the basic machine IC 24 is omitted as are ICs 33-48.

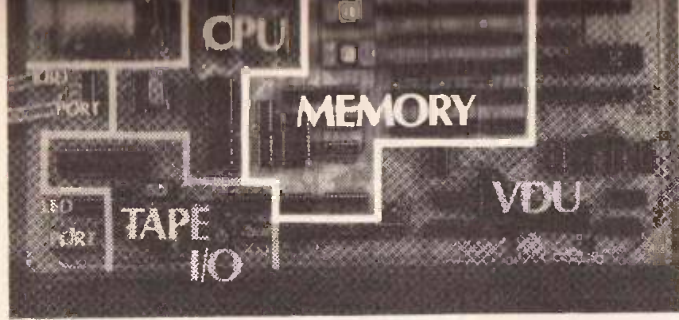

at the junction between R1 and the zener diode. If all is well here; systematically check that you have the correct voltages at the sockets of every integrated circuit. Use the schematic diagrams to help you identify the pin numbers.

Finally check that you have inserted the single wire link to the right of the extender socket.

Insert all the integrated circuits making **absolutely sure** that you have them orientated correctly and have them in the correct locations. Use the dot on the UART to locate pin 1 (the notch can be misleading). Note that the orientation of ICs varies a lot on the board and you must check each one individually. Insert the 2708 EROM chip that is marked MONITOR V4.1 into the socket for IC21; the one marked BASIC L4.1 "A" into the socket for IC22 and BASIC L4.1 "B" into IC23. Insert eight TMS 2111-2 devices in IC locations 25 to 32 inclusive. The only gaps you should have on the board are the IC24 and ICs 33 to 48.

Do not bother with a keyboard at the moment but simply make up a coaxial lead to go from the modulator to the aerial socket of a standard 625 line television set. Switch the TV on and allow it to warm up checking that a raster is just visible and tune it to approximately channel 36.

Set the three on board potentiometers to their mid way

The table shows the decimal and hex codes associated with the Triton graphics and, where applicable, the key on the keyboard. The symbols may be used within a BASIC print statement or with the OUTCH monitor routine.

positions and apply power to the TRITON. You should see some change on the television screen even though you may not be spot on tune. Try adjusting the tuning over the whole range until a strong signal is locked in. You should see the welcome message:

TRITON READY
FUNCTION: PGIOLWT

It may respond with INVALID as the keyboard is not fitted — do not worry this is still an indication that everything is working.

Hopefully this will be the case and you can rest assured that your computer is working! Switch the computer off; wait a few seconds and switch it on again. For a fraction of a second you will see a load of rubbish on the screen which will rapidly clear and the previous message will be repeated.

Switch off and make up an umbilical cord of wires to go from the keyboard socket on the board to the keyboard and associated push switches. Use colour coded wire and ensure that you make no mistake when connecting the relevant leads to the keyboard Cinch connector. It is double sided and you must make sure to hold it with the correct

1	0	00
2	1	01
3	2	02
4	3	03
5	4	04
6	5	05
7	6	06
8	7	07
9	8	08
10	9	09
11	10	0A
12	11	0B
13	12	0C
14	13	0D
14	14	0E
16	15	0F
17	16	10
18	17	11
19	18	12
20	19	13
21	20	14
22	21	15
23	22	16
24	23	17
25	24	18
26	25	19
27	26	1A
28	27	1B
29	28	1C
30	29	1D
31	30	1E
32	31	1F
33	96	60
34	97	61
35	98	62
36	99	63
37	100	64
38	101	65
39	102	66
40	103	67
41	104	68
42	105	69
43	106	6A
44	107	6B
45	108	6C
46	109	6D
47	110	6E
48	111	6F
49	112	70
50	113	71
51	114	72
52	115	73
53	116	74
54	117	75
55	118	76
56	119	77
57	120	78
58	121	79
59	122	7A
60	123	7B
61	124	7C
62	125	7D
63	126	7E
64	127	7F

CONT A
CONT B

CONT E
CONT F
CONT G

CONT N
CONT O
CONT P
CONT Q
CONT R
CONT S
CONT T
CONT U
CONT V
CONT W
CONT X
CONT Y
CONT Z

a
b
c
d
e
f
g
h
i
j
k
l
m
n
o
p
q
r
s
t
u
v
w
x
y
z

RUBOUT

TRITON GRAPHICS

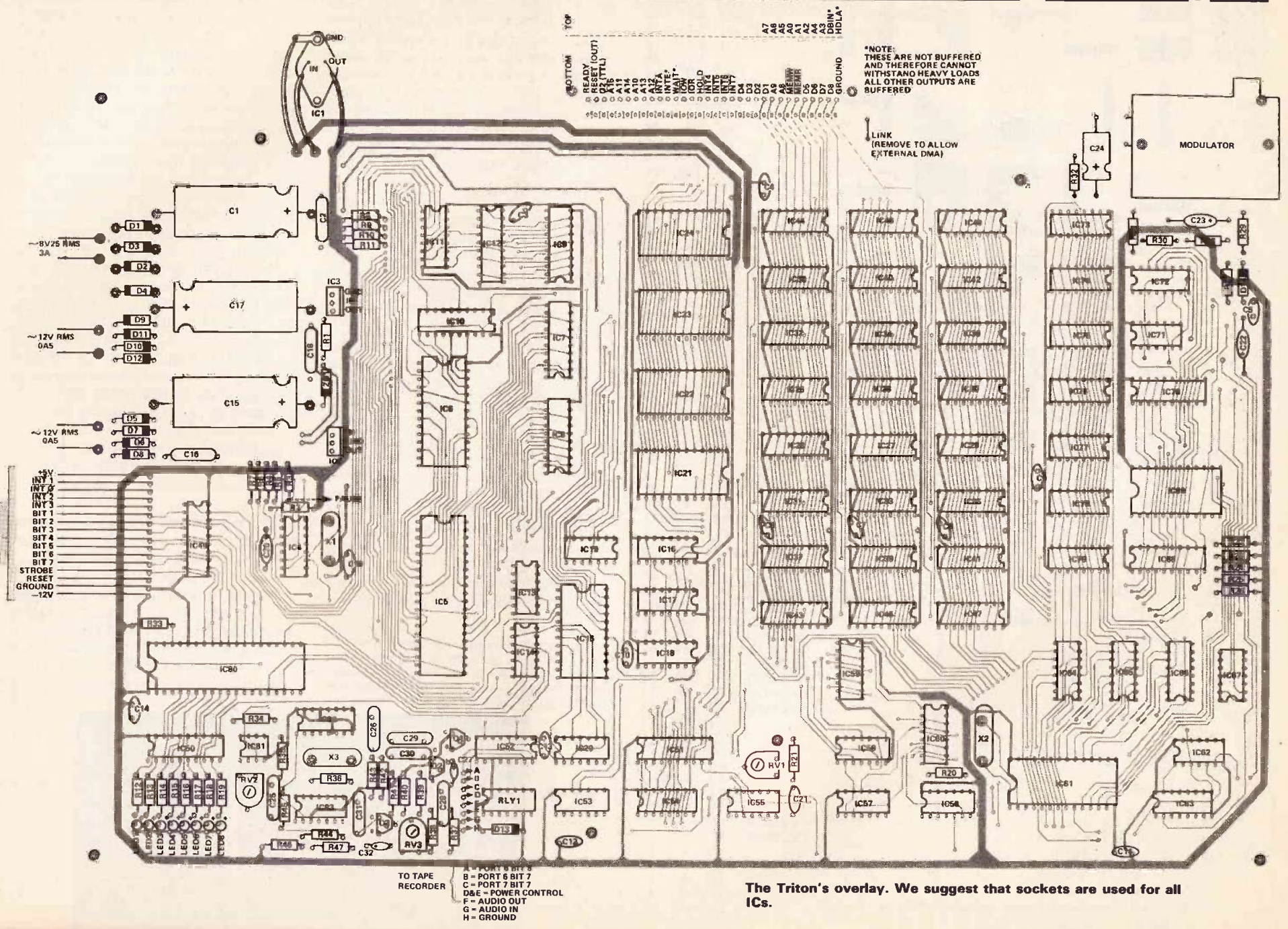

TO TAPE RECORDER
 A = PORT 8 BIT 8
 B = PORT 6 BIT 7
 C = PORT 7 BIT 7
 D & E = POWER CONTROL
 F = AUDIO OUT
 G = AUDIO IN
 H = GROUND

The Triton's overlay. We suggest that sockets are used for all ICs.

PARTS LIST

RESISTORS (all 1/4W 10% unless stated)

R1	82R 1/2W 10%
R2, 34, 44	10k
R3-19, 22-26, 30, 33, 35, 37, 38, 40, 46, 47	1k
R20, 36	4M7
R21, 31	220R
R27	470R
R28, 29	330R
R32	15R
R39	4k7
R41, 45	220k
R42, 43	100k

POTENTIOMETERS

RV1	100R sub. min horiz. preset
RV2, 3	10k sub. min horiz. preset

CAPACITORS

C1, 15, 17	4 700u 25 V electrolytic
C2, 16, 18	470n polyester
C3-14	47n ceramic
C19	47p ceramic
C20, 23, 27, 32	47u 6V3 tantalum
C21	82p ceramic
C22	10u 6V3 tantalum
C24	100u 25 V electrolytic
C25, 29, 30	15n polyester
C26, 28	100n polyester
C31	220n polyester

SEMICONDUCTORS

IC1	LM323K
IC2	LM340T-12
IC3	LM320T-12
IC4	8224N
IC5	8080A
IC6	8228N
IC7, 8, 10, 49	74LS244
IC9	74LS245
IC11	74LS148
IC12	74LS240
IC13, 58	74LS00
IC14, 19, 67	74LS32
IC15	74LS154
IC16	74LS138

IC17, 18	74LS139
IC20	74LS02
IC21, 22, 23, 24	MM2708Q
IC25-48	2111-2
IC50, 51, 68	74LS374
IC52	74LS75
IC53	74LS74
IC54	74S287
IC55	74LS132
IC56, 57, 71	74LS08
IC59, 60, 64, 65, 66	74LS157
IC61	SFC96364
IC62	74LS86
IC63	74LS163
IC69	RO-3-2513
IC70	74S472
IC72	74LS165
IC73-79	2102-2
IC80	AY-5-1013/TMS6011NC
IC81	555
IC82	MC14412VL
IC83	LM339N
D1-4	1N5400
D5-12	1N4001
D13, 14	1N4148
ZD1	5V1 400mW
Q1, 2, 3	BC148
LEDs 1-8	LD35Y (0.1" spacing)

TRANSFORMER

T1	12V + 12V at 0.5A, 8V25 at 3A
----	-------------------------------

SWITCH

PB1	DPDT Mains
PB2-5	SPST

CRYSTALS

X1	7 2000 MHz
X2, 3	1 0000 MHz

MISCELLANEOUS

PCB, Case, DIL Reed Relay type 15005, neon, 3A fuse plus holder, modulator (Astec type 1111E36), Full ASCII Keyboard, 64 way PCB plug and socket (optional) Type CS/CP64, 16 way inline PCB plug and socket Type A23-16, 8 way inline PCB plug and socket Type A23-8, edge connector to suit keyboard, 2 x 5 PIN DIN sockets, IC holders and heatsink (at least 90 x 100mm-matt black).

orientation or you may have disastrous consequences with the power lines. Different types of keyboards have different connections. We refer you to the connection details supplied with your keyboard. The only comment we should make is that the specified keyboard, and some others, give you an option for bit 6 of the data. One option gives you upper case characters only while the other gives both upper and lower case. This application needs the latter. The strobe is the static strobe which goes to "1" as long as a key is depressed.

Procedure

The specified keyboard does not have any built in direct function keys and these have to be provided by separate push buttons. These have to be mounted on the front panel and are used to provide RESET, INT1 (Clear Screen), INT2 (Reset without clearing memory), INT3 (Spare) and TAPE MANUAL OVERRIDE — ganged with PAUSE (see descriptions elsewhere). The first four push switches all have a common ground and are "push to make" with a spring return. Use the Common lead and the respective signal leads to go to each of these switches. The fifth switch must be double pole "push to make — push to break". One pair of contacts should take the special "PAUSE" line to ground when it is on. This line does not exist in the umbilical cord coming from the board socket but must be soldered to the end of R3 going to pin 3 of IC4. The other pair of contacts is connected across the tape power control pins of the respective DIN socket.

You can make up all the above on flying leads to test the unit fully before putting it into its cabinet.

Power up again and get the initialisation message. Try pressing any key on the keyboard EXCEPT PGIOLW or T and the computer should respond by saying INVALID. Press CONTROL C and the screen should clear and re-initialise. Press RESET. When the button is released the same should happen. Try INT2 and the machine should, again, reinitialise. When you try INT1 the screen should clear without the message appearing. To get something back on the screen press any keyboard key except those in the "key character" message (P.G.I.O.L.W.T). You should, once more, get INVALID. Depress CONTROL C once more and your computer is re-initialised and ready for test.

Program

We must assume at this stage that you do not know anything about programming so simply follow the instructions and check that you get what is described.

Depress P on the keyboard. You will get:

P
PROG START =

(The computer is asking you to tell it the address of part of memory you wish to inspect)
Type in 0000 followed by carriage return.
The display will now show:

P
PROG START = 0000
0000 31 (31 is the data in location 0000)

Depress carriage return repeatedly and you will get the following as you step through the Monitor program instructions

```
P
PROG START = 0000
0000 31
0001 80
0002 14
0003 FB
etc
```

Reinitialise with CONTROL C and then type L. The computer will again ask you for a start address but this time will list out the contents of 15 adjacent locations starting from that address. We can use this to test that our memory is there and working in the RAM area.

Answer the computer with the address 1600 and a carriage return (if you make a mistake before you press CR you can backspace with CONTROL H and change an entry but you must then type through the rest of the line on the screen). The computer will list the contents against the memory addresses and then stop and ask for "MORE?". If all is well you should see 00 in all locations. To continue type Y and keep doing this checking all the locations up to the highest order RAM on the board. Above that address the computer will read FF which indicates that there is no memory there. If you see any data above address 15FF that is anything other than 00 or FF you can be sure you have a bad connection to the RAM IC which contains the data in question. This test only holds true immediately after first initialisation and cannot be used if you have attempted to write programs.

To get out of LIST type any character other than Y and the computer will reinitialise. Carry out this or any of the other reset procedures already described and proceed to check the G function. This is to facilitate running a machine code program. The computer will acknowledge

```
G
RUN
PROG START =
```

(this means it is ready to run but wants you to tell it from where in memory it should get its first instruction). Give it this information by typing 02B9 followed by CR. You will actually be running a re-initialisation program in the Monitor which should just acknowledge with



The Triton's board mounted in its case. Note that the extender socket is available on the right hand side of the case and that the output of the modulator is brought out to a UHF socket on the back panel. The back panel also carries the DIN sockets and the mains fuse.

FUNCTION? P G I O L W T

You are now back where you started so you can try typing W which turns the computer into nothing more than a video display typewriter. You can type away to your heart's content testing out all the alpha numeric and graphics characters using the keys in unshifted, shifted, and control mode. Do this while inspecting the coding tables shown in the section describing the VDU and get used to the cursor move commands. Type a full line of characters and adjust RV1 for best line length. To get out of this mode of operation use CONTROL C or any of the other methods of resetting.

The next test sees BASIC L4.1 in action; depress T. The computer acknowledges with

```
T
BASIC L4.1
OK
>
```

Type in NEW followed by CR to make sure the memory is cleared and the computer re-acknowledges with the BASIC header. Very carefully

type in the following message line by line with a CR at the end of each line. Remember you can correct by backspacing with CONTROL H before you hit CR.

```
> 10 FOR A = 1 TO 10
> 20 PRINT "HELLO"
> 30 NEXT A
> RUN
```

You should not re-type the "greater than" prompt signs — the computer is prompting YOU with these. When you press CR after typing RUN we hope you will be surprised — you have just written your first program!

You can now be pretty well assured that your computer is working correctly and it only remains to test and adjust the Tape I/O circuits. This must be done in stages.

First check the Tape Output software. Connect an audio monitor (simple amplifier or crystal earpiece) between the "Tape Out" socket on the board and ground. You should hear a continuous tone. Call up BASIC by typing T and enter the above program again. Once you have done this get back to the Monitor without erasing your BASIC program

(use CONTROL C). Now press O to call up the Tape Output routine.

The computer will ask you for a TAPE HEADER which can be anything you like written in alpha- numerics. Preferably do not use a title longer than 20 characters as you might run out of input buffer space! We suggest you type in TEST ROUTINE. Follow this with CR while listening to the tone on the ear piece. Nothing will happen on the VDU but after a pause of between 5 and 6 seconds (longer if you are using a master clock crystal lower than the 7.20MHz as specified) you will hear about 1 second of regular high speed pulses followed by a few seconds of what can best be described as "burble" (this is your program going out). The burble will stop and you will hear just the continuous tone you heard at the beginning. After a further 5 or 6 seconds the VDU will confirm that the file has finished by displaying END followed by the re-initialisation heading.

On A Plate

Repeat this exercise but this time connect a continuity meter across the tape power control sockets on the board. (The manual override switch must be open circuit). While you type in the tape header code the meter should show that the relay is open circuit but as soon as you depress the CR to start the operation the relay closes and stays closed until the VDU types END. It is obvious that the 5-6 second delay at each end of the routine is to allow a portion of blank tape to go by to reduce the chance of you overlapping files or missing the start of the active tape at the beginning of a new cassette.

You must now set the Baud rate for your system. The simplest way is to use a frequency meter connected to pin 3 of IC81. Adjust RV2 until the meter reads exactly 4800 Hz. A better way, and probably more viable for most constructors, is to use a standard test tape. It is better because different tape recorders might operate at different speeds which would influence the play back baud rate of your system. This does not matter if you are only recording a playing back your own programs but if you wish to use those from other sources your overall system MUST operate at 300 baud. Using a standard test tape calibrates your overall system to 300 baud as viewed from the outside world.

Monitor Manipulation

To carry out this test properly you must have a master clock crystal having a frequency greater than 4.5MHz otherwise the VDU may not print out as fast as the data is coming in from the tape. You must also enter and run a special machine code program to facilitate the test. We will not explain how the program operates in this article except say that it accepts any data on the tape and displays it, verbatim, on the VDU. If garbage is received and decoded garbage will be printed. The test tape contains the alphabet followed by CR and Line Feed repeated many times over a period of a few minutes. All you have to do when the program is running is set RV3 to its midway position and adjust RV2 until you get the alphabet reliably repeated on the screen. If, at the best setting of RV2 you still get the occasional bit of rubbish try altering RV3 for best sensitivity. You should, of course, be using the phono output from your tape recorder but if you do not have this use the extension speaker socket with the volume set about 20% up from minimum.

TRITON Trials

Carry out the following instructions TO THE LETTER!

Initialise the computer with RESET; type in P and enter the start address for the program as 1600. For zero always use 0 and not o. Press CR and location 1600 will be shown to contain 00. Now use the memory change facility to start writing your program. Simply type in the following list of hexadecimal instructions — each pair of digits should be followed by CR. You will end up with a column showing address locations to the right of which is a column showing what was in that location (should have been 00 in all cases) and to the right of that the new data you have just typed in. When you have typed in the complete list of instructions use CONTROL C to re-initialise then type L and list from location 1600 (as previously described). Check that the codes in each location correspond exactly with those in the published program. Use CONTROL C to re-initialise and then type G. Enter 1600 without pressing CR at this stage. Make sure your tape recorder

is properly connected to the board and switch on the recorder in PLAY mode. Press CR and proceed to adjust RV2 as previously described. You should see:

```
ABCDEFGHIJKLMNPOQRSTUVWXYZ
ABCDEFGHIJKLMNPOQRSTUVWXYZ
ABCDEFGHIJKLMNPOQRSTUVWXYZ
ABCDEFGHIJKLMNPO etc
```

until the recording ends or you switch off the tape recorder. While this is happening your computer is locked within a program loop and you will *not* be able to get out of this with CONTROL C. You will have to use INT2 to re-initialise.

Here is the program you must type in:

Address location	Data you must enter
1600	CD
1601	27
1602	03
1603	CD
1604	1D
1605	03
1606	CD
1607	13
1608	00
1609	C3
160A	03
160B	16

Your computer is now completely set up and ready for use. You have already been shown how to enter and run simple programs in BASIC and Machine Code. Why not now read the further articles in the Supplement which will show you how to make more full use of the TRITON. You have made an extremely powerful computer whose applications are only limited by your own imagination and the development of more sophisticated software — coupled with extender boards to give you extra I/O functions (Floppy Disks, Line Printers, extra Tape Recorders, more Memory etc). Keep reading ETI for further exciting applications and developments.

The following pages contain the circuit diagrams and descriptions for the complete Triton design. 'How It Works' sections refer to the diagram they accompany.

Computing Today carries an article on using the Triton's BASIC and a review of the machine by John Coll.

A fuller description of the Triton's monitor will follow in next month's Computing Today.

CPU

PROJECT: Computer

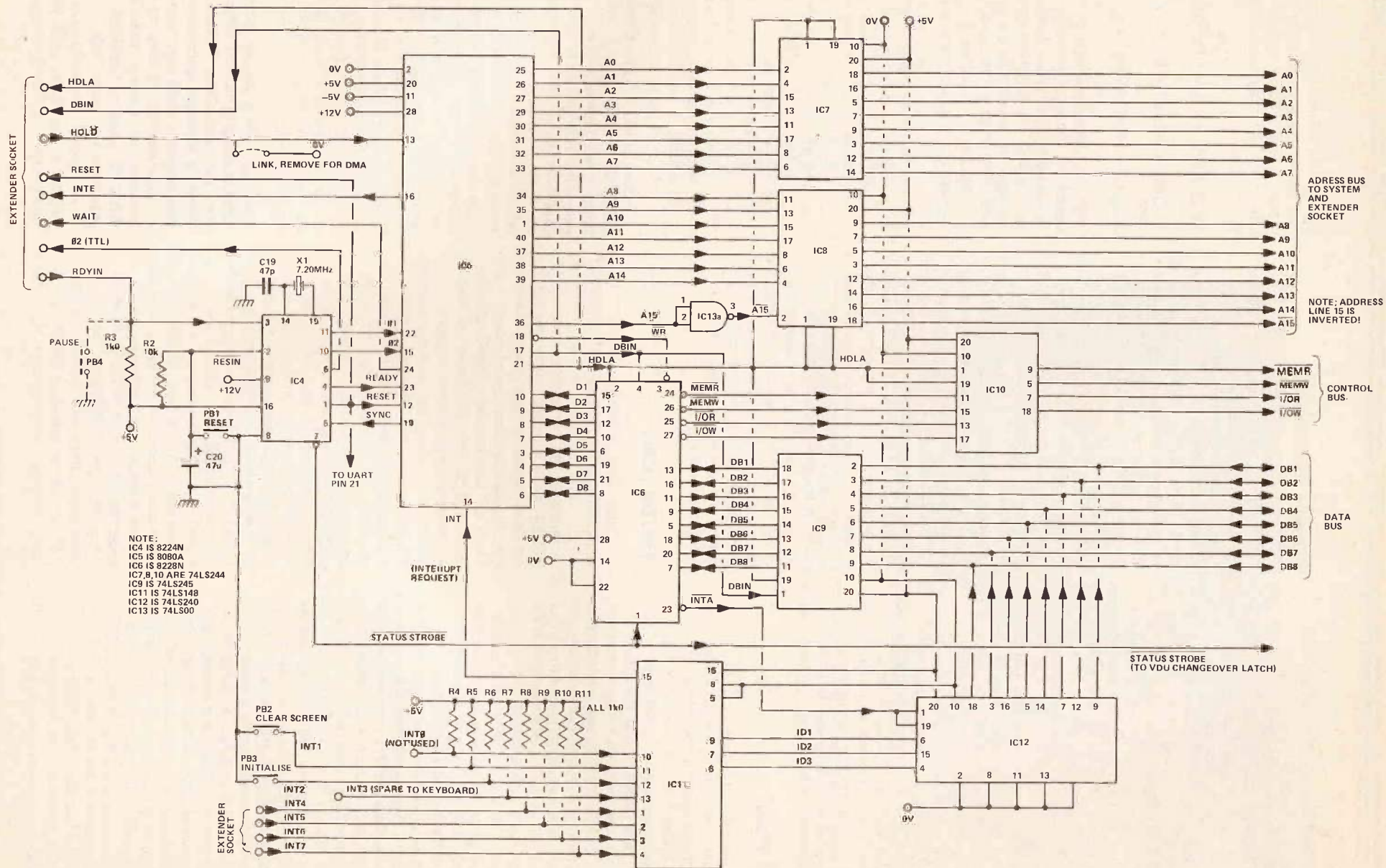

The CPU section of the Triton.

HOW IT WORKS

IC4 is the master clock oscillator which contains divider circuits to provide the two phase clock ($\phi 1$ and $\phi 2$) for the 8080. You can use different frequency crystals for X1 but the ideal value is 7.20MHz and this value should not be exceeded. Lower frequency devices are fine but the system will operate proportionally slower. If you put in a higher frequency crystal not only will you run into memory access time problems but the system will be operating at a rate faster than the VDU can handle. The Monitor program has provided the maximum permissible print out rate for a clock frequency of 7.20MHz.

A TTL compatible output of $\phi 2$ is available but not used on the main board; this is fed to the extender socket. The chip also contains gating circuits to synchronise the externally generated RDYIN command before feeding this to the CPU. An internal Schmitt Trigger on the reset input line (RESIN) allows a very simple charge up circuit comprising R2 and C20 to provide power on reset. Manual reset is carried out by momentarily taking RESIN to 0 volts via a push button. The clock receives a feedback signal (SYNC) from the CPU which is gated with $\phi 1$ to give a STATUS STROBE pulse at the precise moment the data busbars are carrying the status byte. The pulse (STSTB) is fed to the System Control chip (IC6) to latch the status byte and is also used by the VDU to enable Memory Mapping changeover.

C19 discourages the crystals from harmonic operation. This shifts the operating frequency by about 10Hz but this is of no real significance.

A description of the inner workings of the CPU (IC5) is beyond the scope of this article. Its general operations will however become apparent as this How It Works is read.

Note that certain outputs (namely HDLA, DBIN, INTE and WAIT) are taken to the extender socket directly from the CPU. These are unbuffered and account should be taken of this if you expand the system. Each line will adequately drive a single TTL load and maybe a handful if you use low power devices.

The HOLD line going to pin 13 of the 8080 is not used within the main board and is used to carry a DMA request which, via the HDLA signal puts all the busbar buffers into a high impedance state. This could facilitate a take over of the complete memory of this system by a peripheral device or, possibly, another computer. Normally this line should be at logic level "0" so we have hard wired it thus with a board link. This link MUST be removed, or a switch substituted, if use is made of this line!

RDYIN is normally held at level "1". If taken to "0" it causes the CPU to stop operating. Nothing happens as long as the signal is low and the contents of all internal registers within the MPU are maintained. When the signal returns to "1" the MPU carries on operating as if nothing had happened. By taking pin 3 of IC4 via a push switch to ground we have a ready made "PAUSE" control which will enable the TRITON to stop in mid program; say, the middle of long high speed VDU output to inspect the screen.

The chances are very high that you will not need RDYIN for external systems so the feature could be built in permanently. Note should be made that it is bad practice to have a push switch hard wired to ground on this line if at any time in the future you derive the RDYIN signal from a gate. Press the button and bang goes the output stage of one innocent gate.

IC6 is an 8228N 8080 System Controller which gates out the five main control busbar signals from the status byte at the time of STSTB and holds these on latches. The chip also comprises a set of bi-directional buffers for the data busbar; the direction of these buffers is controlled by DBIN and their outputs are disabled on the receipt of a DMA request by the HDLA signal. We were not happy that this buffer alone would be capable of supporting a fully extended system hence a further buffering stage in the shape of IC9 (74LS245). Like the System Controller the latter chip is supervised by the HDLA and DBIN signals. Integrity of any DMA request is maintained on the data bus.

ICs 7 and 8 are uni-directional tri-state buffers which should allow the address busbar to feed a fully extended system. Note that we have inverted A15 prior to putting it on the bus. By doing this we have been able to economise on chip select decoding circuitry elsewhere in the main board system. This

should present no problems to anyone working with extender boards provided that this fact is remembered.

Remember, you must disable the push switch in this mode, that is why we have shown it dotted in and why Transam have not built this facility into their PCB in an obvious way. Why not use common sense and make use of this extremely valuable facility — all that is needed is the cost of 20cms of wire! You do not even need another push switch because you can use a spare pair of contacts on the Tape Control Manual Override. It does not normally matter if you press this button provided the cassette recorder is switched off with its own control.

IC11 is the Interrupt Encoder which has eight lines going in to it. These are normally held high by pull up resistors R4 to R11. The encoded three-bit nibble is output at pins 6, 7 and 9. If all the inputs are high all the outputs are high and a "0" is placed on the Enable Output line at pin 15 (the latter is used to generate the INT signal — Interrupt Request — to the CPU). If any single input is pulled to 0 volts, via the push switches or external logic, an equivalent code to describe that line number is output as the Interrupt Data Nibble and pin 15 goes high telling the MPU that an interrupt has been requested. The MPU will carry on operating until it reaches a perishable point in its cycle to service the interrupt. When this point is reached the MPU outputs an Interrupt Acknowledge signal (INTA) through the status byte which is decoded and latched by the System Controller. This signal is used to activate the Output Enable of IC12 (an eight wide tri-state inverting buffer) which formats the ID nibble to make an eight bit Interrupt Data byte which is then accepted by the CPU as a RESTART instruction. The program counter jumps to one of eight fixed locations in memory — the location is defined by the ID byte — while the STACK preserves all current register data

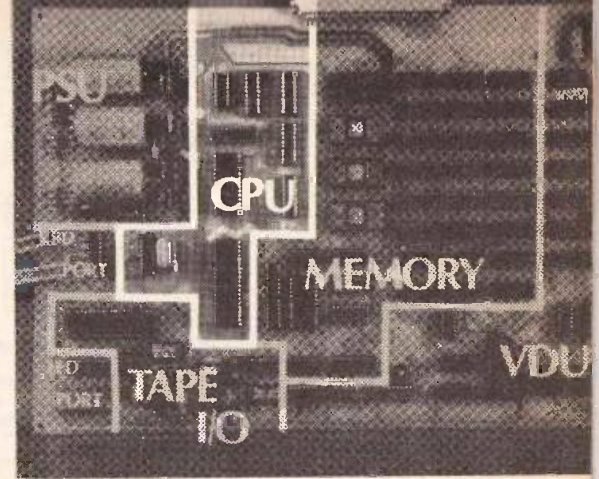

and status information. The MPU then operates on the interrupt routine and returns to its main program when it comes to an RET instruction.

Interrupt 0 should not be used even though it is available on the PCB. It simply duplicates the manual reset operation but would create problems if used with the TRITON's Monitor program. INT1 is dedicated by the Monitor to provide a Clear Screen and Reset Cursor facility which can be carried out at any time. INT2 is also a dedicated function. The Monitor includes memory test facilities as part of the power up routine and use of the reset button will clear all memory. To by-pass this problem we are using INT2 as a non-destructive reset which, as far as any programs that are running are concerned, is just like reset and the system will re-initialise but the memory will not be cleared. ALWAYS use INT2 for reset unless one of your programs has corrupted the Monitors stack!! Only then should you press manual reset or carry out a Power On Reset by switch switching the machine off and on.

Photo of the underside of a section of the Triton's PCB. Note that although it appears that there are no connections to some IC pins — ALL pins must be soldered as these pins are used on the topside of the board.

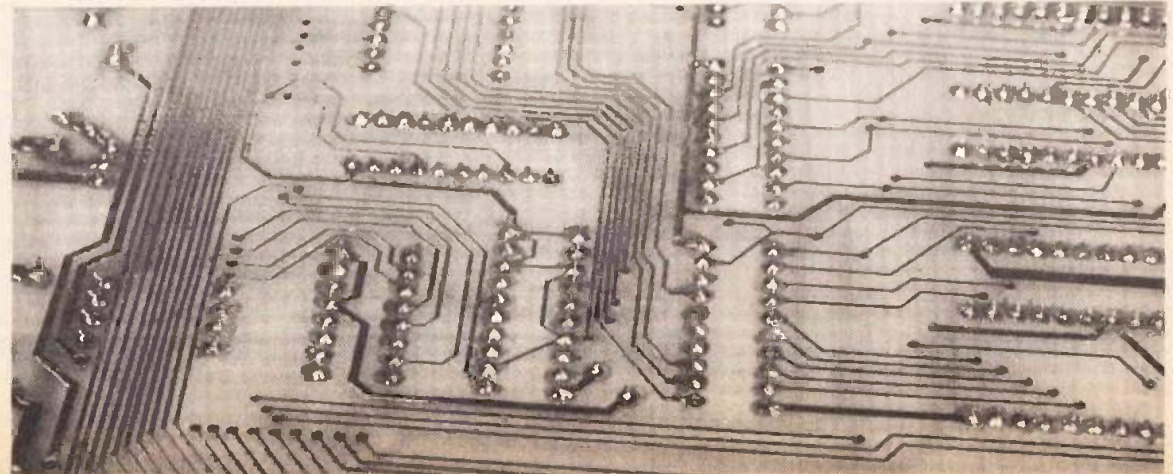

VDU

PROJECT: Computer

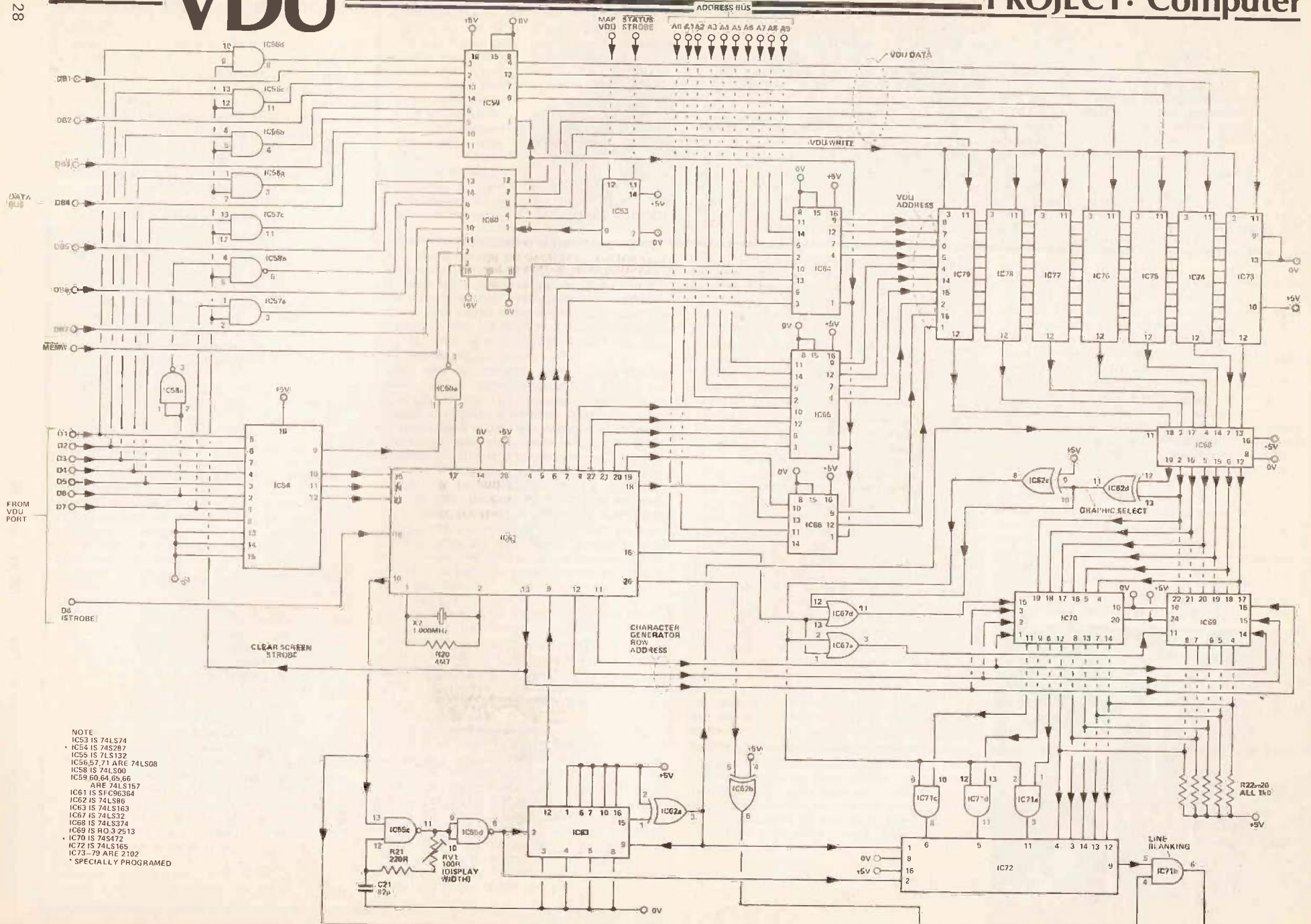

NOTE
 IC53 IS 74LS74
 IC54 IS 74S287
 IC55 IS 74LS132
 IC56,57,71 ARE 74LS08
 IC58 IS 74LS00
 IC59 60,64,65,66 ARE 74LS157
 IC61 IS 51C06304
 IC62 IS 74LS86
 IC63 IS 74LS163
 IC67 IS 74LS32
 IC68 IS 74LS374
 IC69 IS RO.3.2513
 IC70 IS 74S472
 IC72 IS 74LS165
 IC73-79 ARE 2102
 * SPECIALLY PROGRAMED

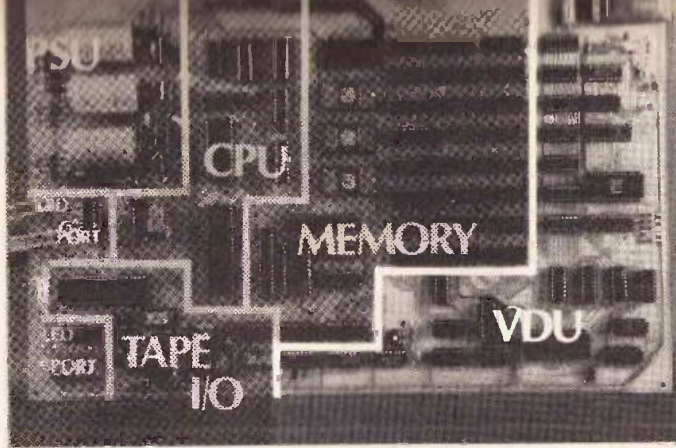

HOW IT WORKS

IC61, the Thomson CFS VDU control integrated circuit, has a built in clock which generates standard TV synchronisation pulses (line and field sync) on pin 26. Random interlace is used and a simplified field sync train is generated as opposed to the full CCIR specification.

The chip, synchronously with this train of pulses, generates addresses for the VDU RAM so that the correct code of the character is selected as the TV raster spot is traversing the respective part of the television screen. An external "Picture Point Oscillator" (IC55c and d) in conjunction with a divider chain (IC63) sets the horizontal width of a character and steps the address of the control chip, output from pin 12 (IC63) to pin 9 (IC61). The inverted output of IC63 pin 15 is used to latch the data being addressed by the controller into IC68 (a seven wide latch), latch the picture point pattern generated by the character generator ROM into the serialiser (IC72) and reset the picture point divider chain (IC63) at the end of each character width.

The picture point width (hence the character width and number of characters per line) is set by the frequency of the oscillator control RV1.

We are using a 7 bit wide RAM to hold the FULL ASCII code — we need this to provide capacity for graphics. The outputs of the latches feed both the standard alpha-numeric character generator (IC69) and a specially programmed ROM (IC70) which contains picture point data for the 64 graphic symbols. We use the EXCLUSIVE OR function (IC62d) on bits 6 and 7 of the ASCII code to select either the graphics or alpha-numeric ROM. The select signals go through further gating (ICs67a and d) to ensure that the integrity of the cursor generating pulse (pin 15 of IC61) is not corrupted.

Three further address lines from the VDU controller (pins 11, 12 and 13) address the picture point data ROWS in both ICs 69 and 70. Due to a limitation caused by the internal operation of IC61 the row address code 000 is output for the top row and the bottom four rows of the character cell. Normally rows 0, 8, 9, 10 and 11 are used to provide inter line gaps for alpha-numeric displays while rows 1 to 7 carry alpha-numeric picture point data. We have had to take this into account when designing the font of graphics symbols — some of which cannot fill the complete character cell rectangle on the screen. Look at the table of graphics characters and you can see how we have adjusted the graphics to suit this restriction.

Further complications caused by this limitation are that a graphic must not appear on the topmost line of the television screen if that graphic contains picture points in its top row. IC61 requires there to be zeros present here in order to derive field blanking. This problem could be overcome with extra gating but this would have been at the expense of simplicity.

A similar problem (involving line blanking) is resolved by gating the video output with the INI function (pin 26 of IC61) in IC71b. Without this any graphics symbol having a picture point in its most left hand column would have caused a "wrap around" while a line that interferes with the DC level of the line sync pulse. The only problem that remains in this respect is that you will now get a single "extra" picture point showing to the right of the 64th character down a line if you use a graphic in the most left hand position of a line. This does not happen with all graphics — only those that have picture points in their most left hand column.

The five outputs from the alpha-numeric ROM are wire ORED with five of the eight

VDU section of the Triton.

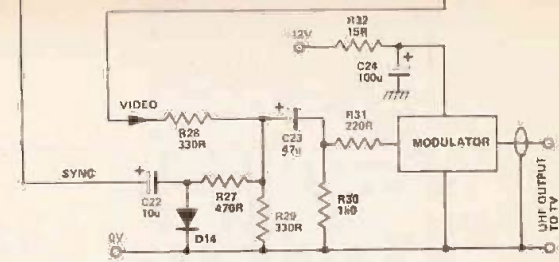

outputs from the graphics ROM and held high via pull up resistors R22 - 26. They are then fed to the correct positions in the serialiser shift register IC72. Note that the remaining three outputs from the graphics ROM have to be ANDED with a signal defining whether or not the character is a graphic (done by ICs71a, c and d). This is to ensure that if alpha- numerics are printed there is a correct inter-character gap.

So far we have avoided talking about how the VDU RAM is addressed by the control chip. Let's deal with that now.

We are allowing the CPU to memory map the VDU RAM. To do this we have had to allow the MPU to take over addressing control of the VDU RAM. This is done by taking all the address lines from IC61 and their equivalents from the system's busbar to a set of data selectors (ICs64, 65 and 66). If the MPU addresses the VDU memory location (any address between 1000H and 13FFH) the block select line (MAP VDU) is activated. This of course, could happen if ever the address busbar went into a high impedance state (during HOLD etc) so to prevent any spurious pulses affecting the operation we gate the VDU block select line with STSTB which only occurs when valid address information is on the busbar. We do the gating in a D type latch so that during the complete cycle of a VDU memory map the data selectors are set to allow the computer address bus to be transmitted to the inputs of the VDU RAM. At the end of that cycle and at all other times the data selectors hand over address control to IC61.

A similar transfer of responsibility takes place between the normal input data to the VDU (which gets to it via an output port) and the main system data bus. In this case the data is selected by ICs59 and 60. These also receive their changeover instruction from the changeover latch IC53. Note that we also have to do a changeover between the internally generated memory write command (pin 17 of IC61) and the MPU's MEMW strobe. This is done within IC60.

It only remains to describe the gates on the VDUs internal data lines and IC54. The former are used to force the ASCII code for "Space" on to the data lines when pin 13 (IC61) is at "O" in coincidence with a writing

pulse to the VDU memory. This is to allow for the very useful internal function provided by the IC61 to clear the screen and reset the cursor in one operation.

The VDU controller carries out a number of non writing functions as well as entering and addressing data within its memory. By using some of the ASCII codes as control it is possible to do such things as move the cursor in steps to any position on the screen, reset the cursor, carry out a line feed or do a carriage return clearing only the unused part of the line. There are also a couple of control codes that we wish the VDU to ignore — OOH and O4H — respectively these are NUL (or no operation) and EOT (end of text) flags. Recognition of all these special codes is carried out by the VDU CONTROL ROM (IC54). This has had to be specially programmed for the TRITON.

To get best use from the TRITON and its VDU you need to know hexadecimal and decimal values of all the ASCII codes that are used to generate alpha- numerics, graphics, and control characters. You also need to know which of the keyboard keys correspond to each graphic character. To help you we show all the graphics with their respective codes and key names in Fig. 00. Alpha-numeric codes are shown in Fig. 00 and the control codes in Fig. 00.

Normally you may output a character to the VDU for printing in I/O mode every 8.3mS. The standard TRITON monitor errs on the safe side and has a built in delay which outputs a character roughly every 9mS. If ever you write your own software you must take this speed limitation into account. Furthermore there are two I/O operations which take a considerably longer time: these are "Clear Screen and Home Cursor" and "Home Cursor". These instructions must be followed by a delay of at least 132mS. Again the TRITON's monitor makes allowance for this but you can get direct access to these functions if you use either the "PRINT CONTROL" or "VDU" commands which exist in BASIC L4.1. If you use these in BASIC you MUST follow them with a delay loop having a time constant greater than 132mS. (In practice we found that a 200 step "FOR — NEXT" instruction was quite safe.)

KBD PORT

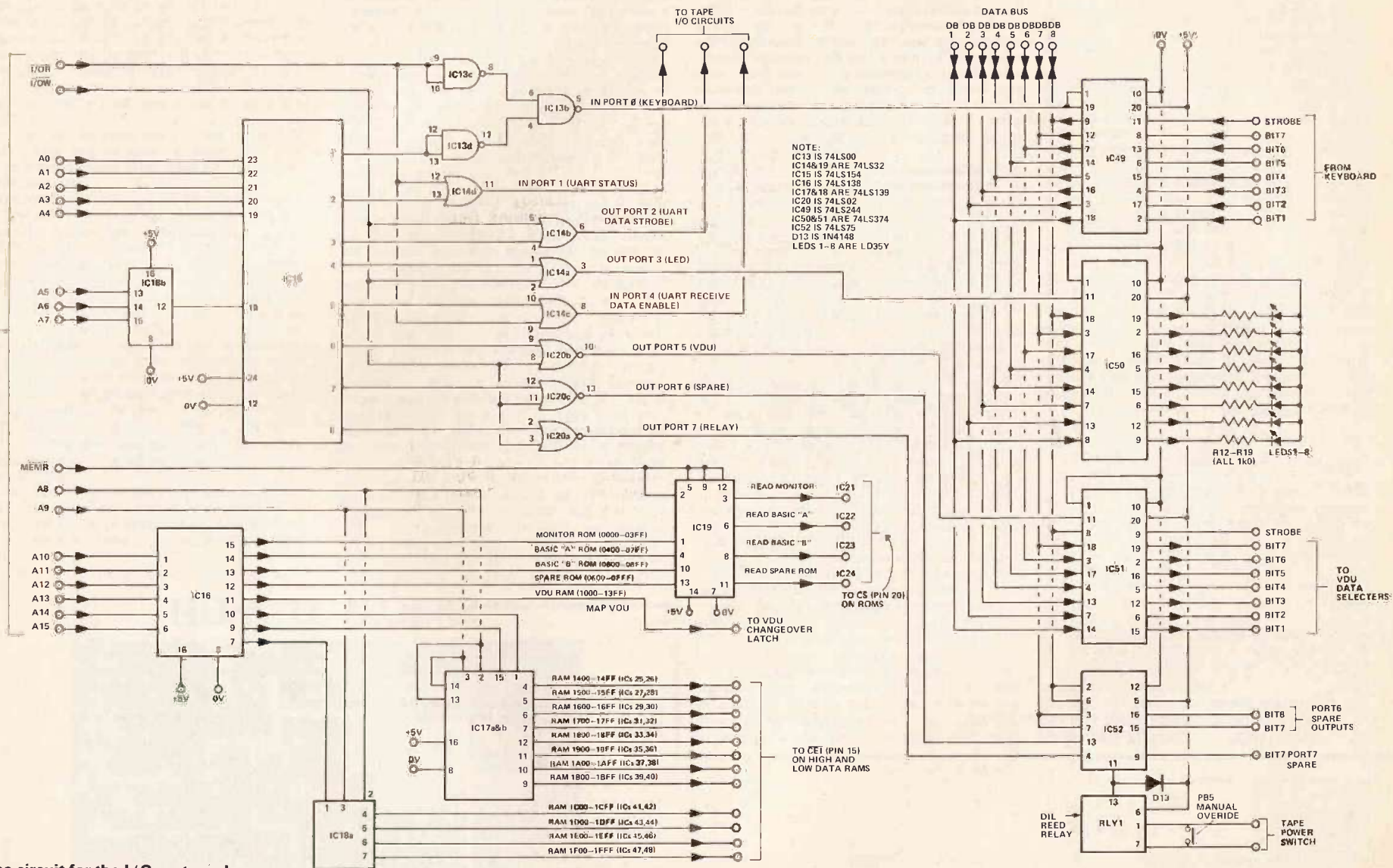

The circuit for the I/O ports and memory select.

HOW IT WORKS

During an INPUT or OUTPUT instruction cycle the MPU will generate the address of the I/O port required on the least 8 significant bits of the address busbar. This has to be decoded to provide a single line signal which will activate the port. It is not sufficient to provide this address on its own because there is no way that the port can tell whether the select signal has come from a genuine port select instruction or whether it is the low order byte of a memory read/write cycle. Furthermore there are times within the machine cycle when the address busbar can be in a transient, or high impedance state which could cause indeterminate address information to be decoded by the port select circuits.

To prevent these problems and also to differentiate between input and output ports the decoded port line is gated with either the I/OR or I/OW control line. One or other of these lines goes to "O" after the ports select address has been placed on the busbar and terminates BEFORE the address data changes. This pulse is of the correct duration to strobe the I/O data on the data bus into or out of the port in question. Take, for example, the control of the Keyboard INPUT port. The port itself is simply an eight wide set of non-inverting tri-state buffers permanently connected to the data bus.

Pins 1 and 19 enable the output of the port when they go to level "O". Normally these pins are at "1" and held there by the output of IC13b and keyboard data cannot affect the data bus. IC18b and 15, between them allow 16 lines to be uniquely decoded from address bits 0 to 7. We only use 8 ports on the main board so part of this facility is redundant hence not all the outputs from IC15 are used. IC18b is a 2 to 4 line decoder operating as a 3 input NAND gate. The reason for this is that the device was one left over in a half used package and its use avoided having to put in an extra IC just for the sake of one 3-input gate. When address OOH is present on the bus pin 1 of IC15 goes low which points to Port 0 (the Keyboard). This signal is ORED with I/OR by IC13c, d and b so when there is coincidence IC49 receives "0" on pins 1 and 19. Whatever data is coming from the keyboard is transmitted on to the data bus and then accepted by the CPU as genuine input data. The reason for using three NAND gates

to provide the OR function is again to use spare capacity in partly used ICs.

While on the subject of the keyboard port some might question the use of only ONE port for the keyboard instead of having a second one to check the status. We get around this apparent deficiency in the INCH (Keyboard Input) sub routine of the monitor. Interconnections with the keyboard put the 7 bits of ASCII on bits 1 to 7 and instead of parity we are using bit 8 to carry the keyboard strobe. Output port 3 works in similar fashion. IC15 decodes its address on pin 4 and IC14a ORs it with, in this case, I/OW. The resultant pulse is used as a clock to the D type latches within IC50. The data is entered into the latches on the rising (trailing) edge of the pulse. Using the trailing edge does not matter here. There is just sufficient current sinking capacity in a 74LS374 (IC50) to drive a small LED direct through a 1k0 limiting resistor. The byte of data is therefore transferred from the busbar to the latches and displayed in binary fashion on the LEDs. Note that the LEDs are illuminated when a "0" is output.

The VDU, when operating in I/O mode, is situated at PORT 5. This works in much the same way as the LED port but we are using a NOR gate to give a positive going port enable pulse. Bits 1 to 7 carry ASCII data and bit 8 the VDU strobe which is formatted to have the correct timing characteristics by the OUTCH (VDU Output) sub-routine of the Monitor program.

A further output port was required to switch the relay of the tape recorder power control (to effect automatic starting and stopping of the tape). Theoretically a single bit port was all that was required but as things turned out in the design this would have required a new integrated circuit (there were no spare latches left over anywhere else!). Because of this it was felt sensible to use a 74LS75 (IC52) which contains four latches connected as two pairs. This way we were able to provide a tape control signal to the relay at pin 11 (the Q output of one latch) by using data bit \bar{a} and this left a spare line on that port (bit 7) which can be used by the experimenter as an output line. The port to call for this line is number 7. At the same time the other pair of latches in IC52 are used as OUTPUT PORT 6 which comprises bits 7 and

8. These are also spare.

As we've moved on to the subject of tape control take note that there is a push button switch connected across the relay contacts. This is to allow manual override so that the cassette recorder can be rewound etc. under manual control without having to unplug the remote control lead. See the relevant section for more details about the serialiser I/O ports and MODEM for the tape recorder.

The memory of TRITON comprises four 1K blocks of ROM, one 1K block of VDU RAM and twelve 256byte blocks of Read/Write RAM. The high order addresses are used to decode individual lines which enable each block while low order addresses point to a specific location within the previously decoded block.

IC16 is a 3 to 8 line decoder but we are able to use it to decode, uniquely, eight individual blocks of 1K from the six most significant address lines. This is made possible by using A15 in inverted form and the internal gated Select inputs of the 74LS138. The four lowest order selected lines correspond to memory blocks which start at 0000H, 0400H, 0800H and 0C00H respectively and these hold the MONITOR, BASIC "A", and BASIC "B" read only memories. The block starting at 0C00H is a spare block reserved for ROM expansion. The line decoded at pin 11 of IC16 addresses the block of VDU RAM and the remaining three lines are fed to three 2 to 4 line decoders ICs 17 and 18a along with address bits A8 and A9.

The latter three decoders break down the remaining 1K blocks into 12 blocks — each containing 256 bytes. Each of these 12 lines goes to a specific pair of random access memory integrated circuits that form the main work area of the computer.

Except for the ROMs, gating with MEMR and MEMW is carried out within the memories themselves. The 2708 read only memories only boast a chip select input and it is necessary to gate the MEMR control signal with each of the chip select lines prior to making connection with the appropriate pin. This gating is carried out by the quad 2 input OR gates contained within IC19.

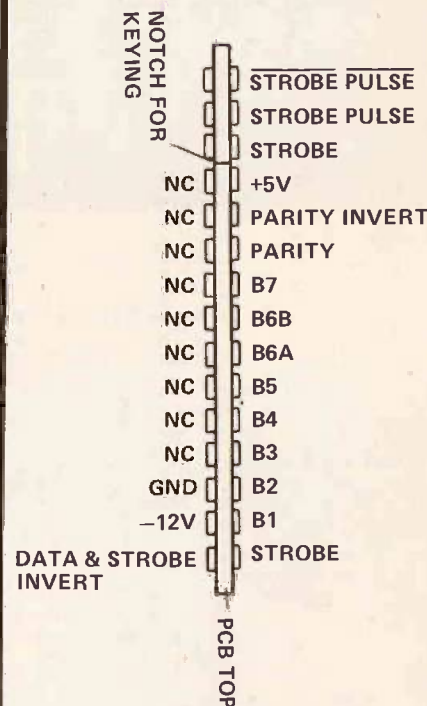
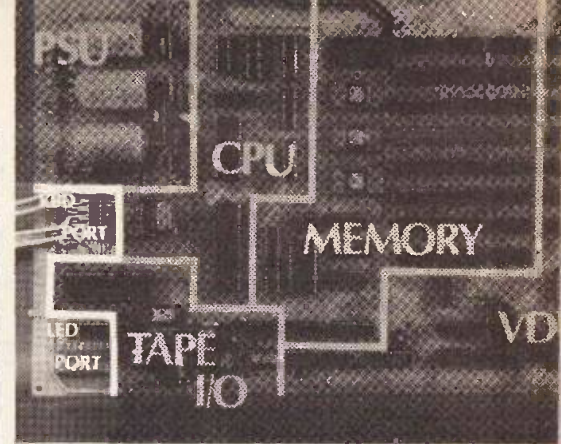

The connection details for the keyboard recommended for the Triton.

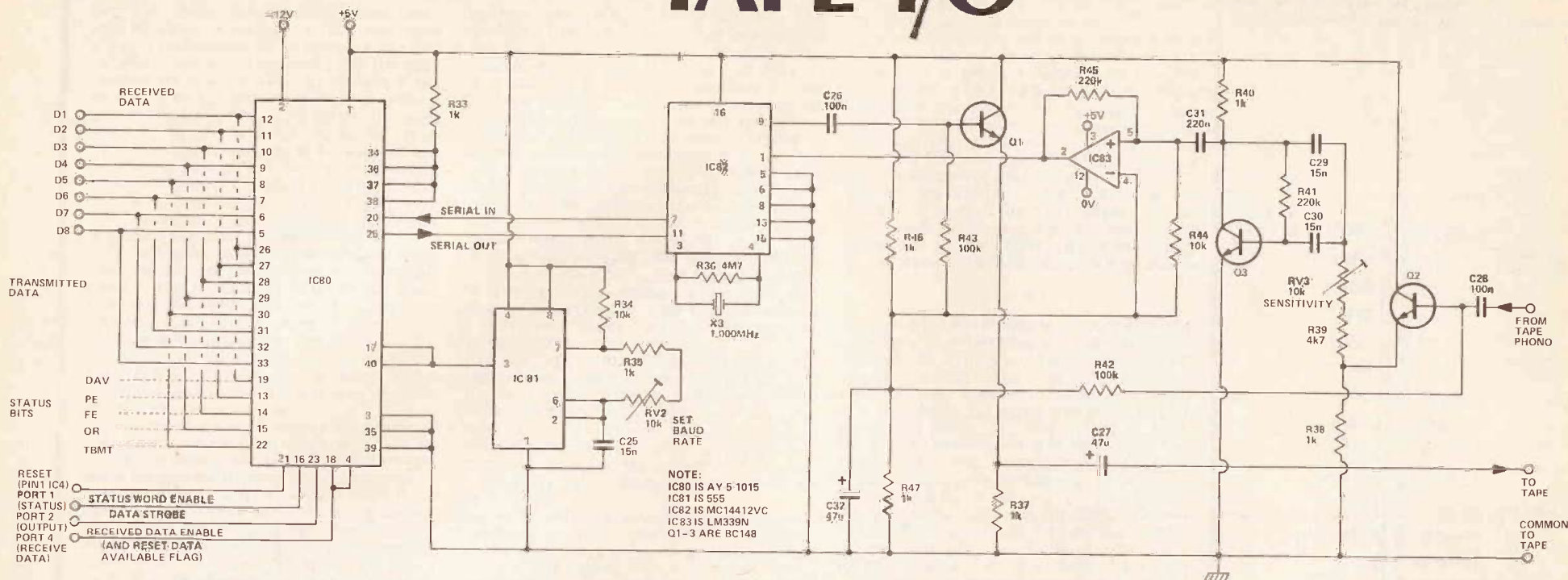

The tape I/O section of the Triton system.

HOW IT WORKS

The AY-5-1013 Universal Asynchronous Receiver transmitter features tri-state outputs for received data and all status bits. Note that respective bits of the data in and data out terminals of the chip are commoned together before joining the TRITON's data bus. The Status bits of the UART are similarly commoned with the DAV (Data Available) bit tied to bit 1 on the bus; PE (Parity Error) to bit 2; FE (Framing Error) to bit 3; OR (Over Run Error) to bit 4 and TBMT (Transmitter Buffer empty) to bit 5. Note however that TRITON's standard Monitor only samples DAV and TBMT.

The DAV and TBMT flags are used to tell the system when the UART has received and has ready a complete byte of new data or when the UART has finished a current serialising cycle and is ready to accept a new byte for transmission. In actual fact the UART will accept a second byte while it is still transmitting the first due to the double buffering nature of its transmitter buffer.

should be set on a frequency meter.

In order to transmit data the TRITON Monitor first checks to see whether the UART transmitter buffer is empty by activating the STATUS WORD ENABLE which is, in effect, PORT 1. This places the status word on the data bus and the MPU checks to see whether bit 5 (TBMT) flag is at "1". If so it indicates that the UART is ready and the Monitor then outputs its data on to the busbar while activating the DATA STROBE (PORT 2). DATA STROBE starts the transmission serialising cycle and the serial data is output to the MODEM (IC82) at pin 25. If the TBMT flag was at "0" the Monitor goes into a loop and waits until the UART is ready.

In order to receive data the MPU asks for status information, again through input port 1 but this time checks bit 1 (the Data Available flag). This goes high as soon as a complete serial byte has been received and formatted into parallel form in the UART's

byte of data is received. Clearly the software cycle, which carries out this operation, MUST have a shorter loop period than the period between one received byte and the next otherwise overrun errors will occur.

The Motorola single chip MODEM seemed highly attractive from the word go as it is extremely economical on external components and needs no adjustment.

The MC14412VL is such a versatile chip that it was again difficult to decide which mode it should be used in. Eventually, in order to have a frequency pair that would give best reliability with most tape recorders and to allow the MODEM to receive at up to 600 baud (not that this is used at present) we opted to go for the USA standard "originate" mode in which the transmitted frequency pair is:

MARK ("1") = 1,270 Hz
 SPACE ("0") = 1,070 Hz

Clearly we need to be able to demodulate the same pair of frequencies so have to

The MODEM interfaces directly with the UART and only needs a crystal and resistor to lock it to the correct frequency pairs. It is most important that a crystal of exactly 1,000MHz is used here otherwise you will not be able to use pre-recorded tapes! The transmitted carrier of the MODEM is an eight level digitally synthesised sine wave of about 300mVrms which is buffered by TR1 before being fed via C27 to the tape recorder phono input.

To carry out a demodulation satisfactorily the MODEM IC requires a very precise unity mark/space waveform at pin 1. The tolerance on the mark/space ratio has to be better than $\pm 4\%$. If the carrier being played back from the recorder carries any harmonic distortion this will result in an asymmetric sinusoid which will be difficult to convert to a square wave of the above specification. To further purify the sine wave it is amplified and filtered by Q3. To some extent the input sensitivity can be adjusted by RV3 but under

The format of serialised data in TRITON is a START bit, 8 data bits, a parity bit and 2 STOP bits. These are transmitted at a rate of 300 baud set by the clock comprising IC81 (4013 NE 555). Baud rate is adjustable by about ± 50 percent by means of RV2 and, of course, it is important that this is accurately set if tapes from other sources (recorded in TRITON's format) are to be played back. To obtain a rate of 300 baud the oscillator must run at precisely 4800 Hz and ideally this

output latches. The MPU will loop until this condition is met. When the flag goes to "1" the MPU uses port 4 to send a "Received Data Enable" strobe to the UART. This enables the outputs of the receiver buffer latches and places the data byte on the system busbar. To prevent the system reacting a second time to the same DAV flag the pulse from port 4 is also used to reset DAV which then stays low until a completely new

operate in Simplex mode hence pins 2, 10 and 14 of IC82 are allowed to be "1". Internal pull up resistors within the chip do away with the need for external pull ups hanging on these pins! Pin 2 actually is the "Self Test" control input which makes the MODEM's receiver demodulate the same frequency pair that is being transmitted. Keeping this active prevents any ambiguity as to whether one is "originating" or "answering".

normal circumstances (within the range of input voltages mentioned above) this should always be set in its mid-point position. The high purity sine wave at the collector of Q3 is fed to IC83 which is a zero crossing comparator which will sense the zero crossing of a sine wave to within about 3mV. With a good input signal this results in a square wave that more than adequately meets the input specification of the MODEM.

PSU

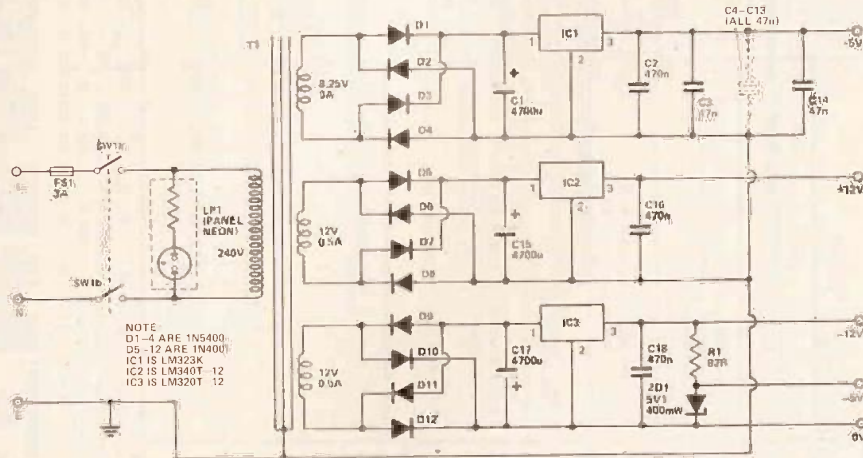

The power supply section of the Triton is based on three terminal regulators.

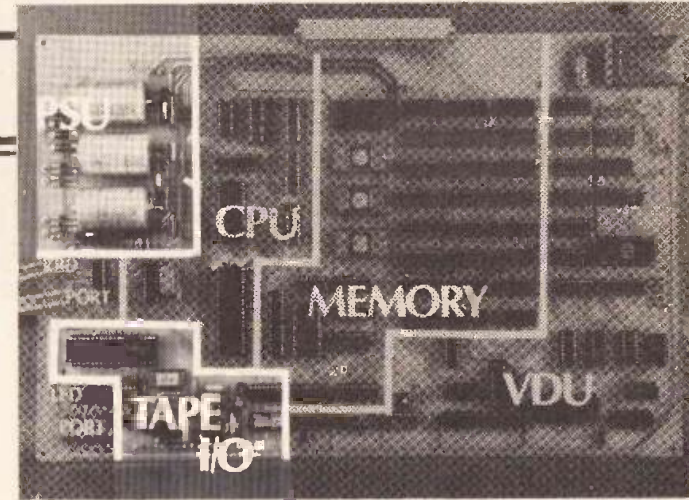

A close-up photograph of the PSU. Note the orientation of the IC regulators.

HOW IT WORKS

THE POWER supply has been kept as simple as possible, utilising three IC regulators to provide the main rail supplies which are +5 V at 3 A (the TRITON does not draw all this but do not rely on there being any to spare if you are thinking of hanging any other bits and pieces on this line!) +12 V at 0.5 A and -12 V at 0.5 A. A few milliamps are needed by the ROMs and the 8080 at -5 V and this is catered for by a simple zener shunt off the -12 V rail.

The ± 12 V rails are straightforward. Dissipation by the regulators is low and no heat

sinks are necessary. The 470n capacitors on the outputs of the regulators are to prevent any parasitic oscillations. Note that the +5 V rail has a dozen 47n capacitors (C3 to C14) shunted across it. These are anti-spiking devices and have been placed in strategic places on the board.

To avoid excessive dissipation in the main +5V regulator (IC1) we decided on a specially wound mains transformer, hence the rather obscure specification for an 8.25 V winding.

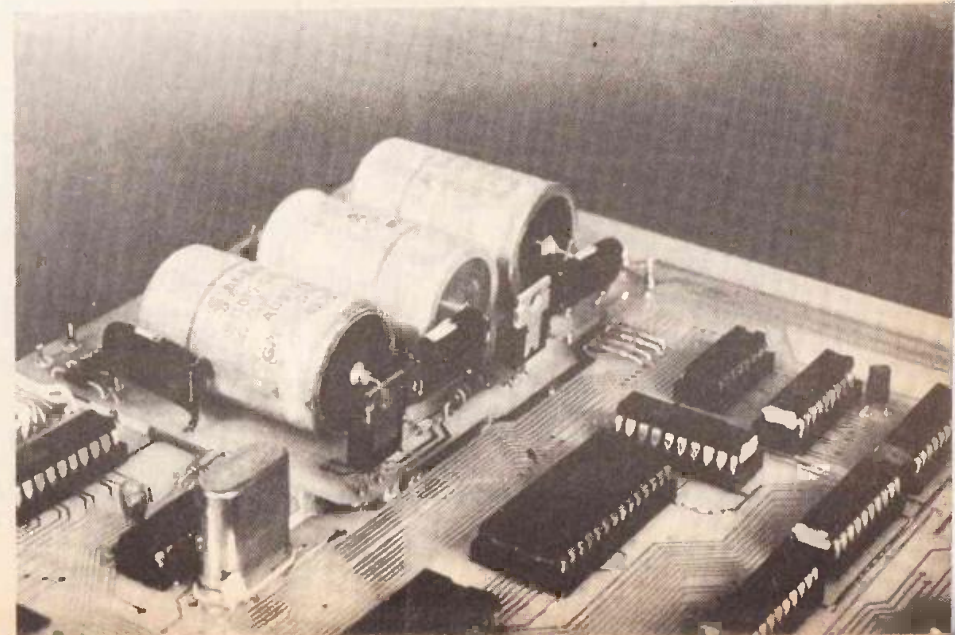

ETI BOOK SERVICE

BEGINNERS

Beginners Guide to **Electronics** Squares £2.65
Beginners Guide to **Transistors** Reddihough £2.65
Electronic Measurement Simplified C. Hallmark £2.20
Electronics Self Taught Ashe £4.40
Beginners Guide to **Integrated Circuits** Sinclair £3.15
Principles of **Transistor Circuits** S. Amos £4.75
Understanding **Electronic Circuits** Sinclair £4.10
Understanding **Electronic Components** Sinclair £4.10
Beginners Guide to **Radio** King £3.15
Beginners Guide to **Audio** Sinclair £3.10
Beginners Guide to **Audio** I. R. Sinclair £3.20

COOKBOOKS

TV Typewriters Cookbook £7.40
CMOS Cookbook £8.00
TTL Cookbook £7.55
Active Filters £11.00
IC Timer Cookbook £7.50
IC Op-Amp Cookbook £9.40

APPLICATIONS

Advanced Applications for **Pocket Calculators** J. Colbert £4.20
Build Your Own Working **Robot** D. Heiseman £3.55
Electronics and Photography R. Brown £2.30
Fire and Theft Security Systems B. Welk £2.00
How To Build **Proximity Detectors and Metal Locators** J. Shields £3.35
How To Build **Electronics Kits** Capel £2.10
Linear Integrated Circuit Applications G. Clayton £5.40
Function Circuits Design & Applications Burr Brown £15.95
110 Electronic Alarm Projects R. M. Marston £3.45
110 Semiconductor Projects for the Home Constructor R. M. Marston £3.25
110 Integrated Circuit Projects for the Home Constructor R. M. Marston £3.25
110 Thyristor Projects Using SCRs R. M. Marston £2.95
Handbook of IC Circuit Projects Ashe £2.30
Practical Electronic Project Building Ansie and Culwell £2.45

TV AND HI-FI

Audio Handbook G. King £6.50
Cassette Tape Recorders J. Eoff £5.25
Solid State Colour TV Circuits G. R. Widing £6.35
Hi-Fi Loudspeakers and Enclosures Cohen £8.20
How To Build Speaker Enclosures Badmirell £3.10
Master Hi-Fi Installation King £2.80

LOGIC

Logic Design Projects Using Standard ICs J. Warkels £5.10
Practical Digital Design Using ICs J. Greenfield £12.50
Designing With TTL Integrated Circuits Texas Instruments £9.05
How To Use IC Circuit Logic Elements J. Shields £3.65
110 COSMOS Digital IC Projects for the Home Constructor R. M. Marston £3.20
Understanding CMOS Integrated Circuits R. M. Marston £3.90
Digital Electronic Circuits and Systems R. M. Marston £3.50
MOS DIGITAL ICs G. Egan £4.60

COMPUTING

Microprocessors and Microcomputers B. Snowick £18.00
Microprocessors D. C. McGlynn £8.40
Introduction to Microprocessors Aspinall £5.90
Modern Guide to Digital Logic (Processors, Memories and Interfaces) £4.30

OP-AMPS

Applications of Operational Amplifiers Graeme (Burr Brown) £8.30
Designing With Operational Amplifiers Burr Brown £13.75
Experiments With Operational Amplifiers Clayton £3.40
110 Operational Amplifier Projects for the Home Constructor R. M. Marston £2.95
Operational Amplifiers Design and Applications G. Tobery (Burr Brown) £7.40
Op-Amp Circuit Design & Applications I. Carr £4.00

TEST INSTRUMENTS

The **Oscilloscope In Use** Sinclair £3.10
Test Instruments for Electronics M. Clifford £2.40
Working With the Oscilloscope A. Saunders £1.95
Servicing With the Oscilloscope G. King £5.60
Radio Television and Audio Test Instruments King £5.90

SERVICING

Electronic Fault Diagnosis Sinclair £3.20
Rapid Servicing of Transistor Equipment G. King £2.95
Tape Recorder servicing Manual Gardner Vol 1: 1968-70 £8.50
Vol 2: 1971-74 £8.50
FM Radio Servicing Handbook King £4.80
Basic Electronic Test Procedures I. M. Guttie £2.45

COMMUNICATIONS

Communication Systems Intro To Signals & Noise B. Carlson £7.50
Digital Signal Processing Theory & Applications I. R. Rabiner £23.80
Electronic Communication Systems G. Kennedy £8.50
Frequency Synthesis. Theory & Design Mannassewitsch £20.40
Principles of Communication Systems H. Taub £8.10

THEORY

Introduction to Digital Filtering Bogner £9.40
Transistor Circuit Design Texas Instruments £9.35
Essential Formulae for Electrical and Electronic Engineers N. M. Morris £1.65
Modern Electronic Maths Clifford £6.70
Semiconductor Circuit Elements T. D. Towers £6.40
Foundations of Wireless Electronics M. G. Scroggie £4.45
Colour Television Theory Hudson £6.20

REFERENCE

Transistor Tabelle (Includes physical dimensions) £4.10
Electronic Engineers Reference Book (Ed. 4) L. W. Turner £27.70
Solid State Circuit Guide Book B. Ward £2.25
Electronic Components M. A. Culwell £2.45
Electronic Diagrams M. A. Culwell £2.45
Indexed Guide to Modern Electronic Circuits Goodman £2.30
International Transistor Selector T. D. Towers £5.25
International FET Selector T. D. Towers £4.35
Popular Valve/Transistor Substitution Guide £2.25
Radio Valve and Semiconductor Data A. M. Bell £2.60
Master Transistor/Integrated Circuit Substitution Handbook £5.60
World Radio TV Handbook 1978 (Station Directory) £8.00
Radio, TV and Audio Technical Reference Amos £24.85
TV Technicians Bench Manual (New Ed.) Widing £5.10

MISCELLANEOUS

Integrated Electronics D. Milman £7.70
Microelectronics Hallmark £3.90
Practical Solid State DC Supplies T. D. Towers £6.20
Practical Triac/SCR Projects for the Experimenter R. Fox £2.25
Printed Circuit Assembly Hughes & Culwell £2.45

Fallen behind recent advances?

Just starting out?

Need a decent reference book?

ETI Book Service provides an easy way of getting your hands on the right title.

How to order: Make cheques etc payable to ETI Book Service. Payment in sterling only please. Orders should be sent to: ETI Book Service, PO Box 79, Maidenhead, Berks. All prices include P&P.



Wilmslow Audio

THE firm for speakers!

Send 15p stamp for the world's best catalogue of Speakers, Drive Units, Kits, Crossovers, etc., and discount price list

ATC ● AUDAX ● BAKER ● BOWERS & WILKINS
 ● CASTLE ● CELESTION ● CHARTWELL ●
 COLES ● DALESFORD ● DECCA ● EMI ● EAGLE
 ● ELAC ● FANE ● GAUSS ● GOODMAN'S ●
 HELME ● I.M.F. ● ISOPHON ● JR ● JORDAN
 WATTS ● KEF ● LEAK ● LOWTHER ●
 MCKENZIE ● MONITOR AUDIO ● PEERLESS ●
 RADFORD ● RAM ● RICHARD ALLAN ● SEAS ●
 TANNoy ● VIDEOTONE ● WHARFEDALE

WILMSLOW AUDIO Dept. ET1

SWAN WORKS, BANK SQUARE, WILMSLOW,
 CHESHIRE, SK9 1HF
 Discount HiFi, etc., at 5 Swan Street and 10 Swan
 Street
 TEL: WILMSLOW 29599 FOR SPEAKERS
 WILMSLOW 26213 FOR HIFI



TARGET ELECTRONICS

FORMERLY "THE RADIO SHOP"

16 Cherry Lane
Bristol BS1 3NG

Telephone:
0272-421196

Official orders welcomed Gvt / Educational Depts etc

Size 60 mm x 45mm x 40mm



PANEL METER with ILLUMINATION WIRING

Dials are clearly figured on bright white for easy reading. 2.5% F.S.D. accuracy. Zero adjustment at front. Cushioned pointer stops. Complete with mounting nuts and washers.

Prewired and have lamp terminals installed on rear. Snap off front cover and insert Lamp Kit (opp extra) 65p

Two 6.3V bulbs for press-in fitting onto pre-wired connector blocks which require 12.6V external power through the rear terminals already fitted

TRANSFORMERS

PRIMARYS 240V

TR1	6-0-6	100MA	80p
TR2	9-0-9	75MA	83p
TR3	12-0-12	50MA	90p
TR4	12-0-12	100MA	£1.10
TR1A	6-0-6	100MA	92p
		Int screen	
TR2A	9-0-9	75MA	£1.00
		Int screen	
TR3A	12-0-12	50MA	£1.10
		Int screen	

●MOT Output Transformer 1 2K-8ohm 200MW P&P 27p

P&P for above 25p



NASCOM 1 Z80 MICROCOMPUTER KIT

Includes interface for: TV or Monitor — cassette, dump — Teletype — spare, PIO, Expansion RAM-BOARD up to 32K.

Potential: High Level Language, Mini Floppy Disk, Excellent Z80 evaluation kit. £197.50 + VAT. P&P £2 50

● Please add 12½% VAT. Remainder 8% VAT

Large selection of aluminium boxes & Instrument Cases

Phone in your Access or Barclaycard order. Catalogue 25p post paid.



BONA FIDE UK TRADERS ONLY!

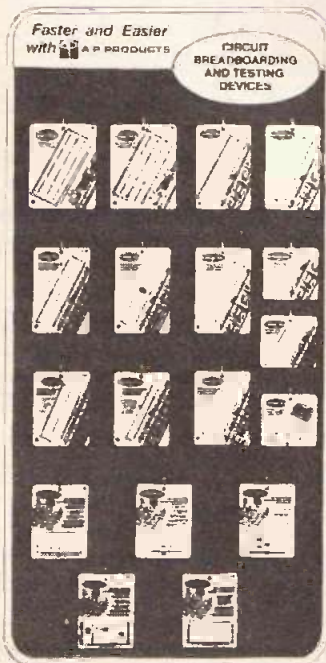

THIS IS THE PLACE
FASTER AND EASIER BEGINS.

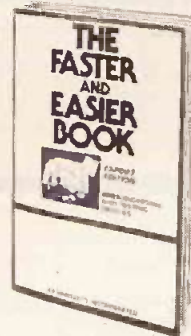

A Fast and Easy Profit Message from Lektrokit

For hobbyists and home project constructors, Lektrokit have put together the most comprehensive range of breadboarding and testing devices on earth.

For you, Lektrokit have display racks, window

stickers and catalogues to help you sell the entire range—faster and easier.

For you, too, Lektrokit will be advertising to hobbyists and home project constructors continuously—telling them about the Lektrokit products that you supply.

If, of course, you have the stocks. And that's up to you.

Launch dates for Lektrokit's exciting new range are November 21-25—at

BREADBOARD 1978—but you can get in on it NOW! Just use the coupon.

LEKTROKIT completes the circuit

To Lektrokit Ltd., Sutton Industrial Park, Earley, Reading, Berks RG6 1AZ. Telephone 0734 669116.

I am a bona fide UK trader. Please send full information about faster and easier profit by Lektrokit.

Name _____ Address _____

Tel. _____

ET1

VENUS PROBE

Venus, the shrouded planet of Edgar Rice Burroughs and Ray Bradbury, has fascinated men and telescopes for many decades. It was the favourite choice to house monsters and the scientists' choice for life of a more mundane type. Conditions are not that favourable, however, but are still interesting enough to warrant the launch of the Multiprobe which should tidy up some of the mysteries remaining.



Fig. 1. The Pioneer Venus Multiprobe spacecraft; a thermal test model is shown.

THE TWO Pioneer spacecraft should reach Venus around the end of this year, being scheduled to reach orbit on the 4th December. One of these probes, known as the 'Orbiter', will circle the planet for at least one Venusian year. It will collect data on the upper atmosphere of the planet (including field strengths and the types of particle present) and will also record events occurring on a global scale on or around the planet over a fairly long period of time.

The other spacecraft will consist of a transporting vehicle, known as a 'Bus', which will convey one large probe and three small probes to Venus. All five parts of this spacecraft will enter the Venusian atmosphere at widely separated points and will transmit data back to earth. The four probes will fall to the surface of the planet and should provide much information about the lower atmosphere at four widely separated points.

Although Venus is our closest planetary neighbour, it is always covered in very thick cloud; our knowledge of this planet is therefore very limited, especially as regards its lower atmosphere. The early probes have shown that Venus has a high surface temperature and an atmospheric pressure nearly one hundred times that of the earth, but a great deal of work remains to be carried out. It is expected that the two Pioneer spacecraft will increase our knowledge of this planet by a factor of about ten. They will also greatly increase our knowledge of the solar system and are expected to provide much information which will add to our theories about the origin of the earth.

Pioneering Spirit

The Pioneer missions were conceived as long ago as 1970 as a result of recommendations made by the Space Science Board of the US National Academy of

Sciences who decided that there is a need for relatively low cost orbiter and probe landing systems for Venus investigations. Overall responsibility and control of the mission has been given to the National Aeronautic and Space Administration (NASA) Research Centre at Moffett Field, California.

The Hughes Aircraft Company gained a contract to manufacture both space vehicles for the Pioneer mission in February 1974 after a series of competitions which started in 1972. The scientific instrument payloads were selected in June 1974, thirty instruments being included on the list. The spacecraft will be launched on top of Atlas SLV-3D Centaur D-1AR rockets from Cape Canaveral, Florida. The vehicle tracking, command signal transmission and data reception will be carried out by the established US Deep Space Network stations in California, Spain and Australia.

The Multiprobe Mission

The Bus, the large probe and each of the small probes include payloads of scientific instruments. The Bus will be destroyed by burn-up in the Venusian atmosphere after its two instruments have transmitted data back to earth. It is, perhaps, somewhat surprising that work on the atmosphere and weather on Venus is expected to teach us more about the weather on earth.

The multiprobe vehicle is a circular, spin-stabilised craft with an array of solar cells around its exterior. The large probe will examine the atmosphere surrounding the planet, measuring the clouds, the atmospheric composition, etc. The three identical small probes will separate and enter the atmosphere some 7,000 miles apart two of them on the dark (night) side. They will collect information on the general circulation of the lower atmosphere. ▶

Structure

The structure of the multiprobe unit is shown in the exploded view of Fig. 2. The cylindrical solar panel is 2.54 m (100 inches) in diameter and 1.22 m in length. The equipment shelf is 2.47 m in diameter, the electronic units and the scientific instruments being mounted on this shelf.

The large probe is at the centre of the spacecraft on an inverted conical structure, whilst the three small probes are symmetrically placed around the main probe. Each probe is fixed by spring loaded clamps which can be released (pyrotechnically) about 20 days before the craft arrives at Venus so that the five sections move independently.

The probe weight, including the interfacing connection with the launching vehicle, is designed to be 920 kg. Great care has been taken in the thermal design of the craft to ensure that the temperature is kept between suitable limits; heaters and thermal blankets are included and appropriate materials with suitable thermal properties are used.

The control system employs a sun sensor and a solid state sensor which can detect the radiation from 24 stars. The vehicle contains two tanks which will be filled with 32 kg of liquid hydrazine propellant. When this liquid is allowed to pass into a chamber containing a suitable catalyst, it decomposes into nitrogen and provides a thrust of about 0.5 kg as a jet for controlling the spacecraft's trajectory, attitude and spin rate.

The power for the spacecraft is obtained from the cylindrical array of solar cells which has an area of just over 6 square metres. This provides 228 W when the

spacecraft is near the earth, but extra power can be obtained for a limited time from two 7.5A-hr nickel-cadmium batteries. The solar cells and batteries provide a 28 V supply; overload protection and undervoltage detection circuits are included in the power supply system.

Command signals are transmitted from the Deep Space Network ground stations to the Bus at 4 bits/second using pulse code modulation or frequency shift keying. The electronic on-board equipment can store command instructions for execution at some later time. Six command output modules on the equipment shelf can distribute 384 pulse commands and 12 quantitative (or analogue) commands to scientific instruments and to the spacecraft units. Commands from the earth stations modulated onto a 2115 MHz carrier wave are received by the spacecraft transponders.

Data for transmission to the ground is convolutionally encoded, assembled into 8 bit words in a 64-word frame and modulated into a data stream. Eight data input modules on the equipment shelf can receive the signals and establish up to 253 data channels with the telemetry processor for transmission to earth.

The data is transmitted on a 2300 MHz beam at a power of 10 or 20 W using one of three antennas and a data rate of between 8 and 2048 bits/second. The antennas comprise two omnidirectional types (forward and aft) to provide spherical coverage at both the transmit and receive frequencies together with a medium gain horn antenna at the aft end of the craft.

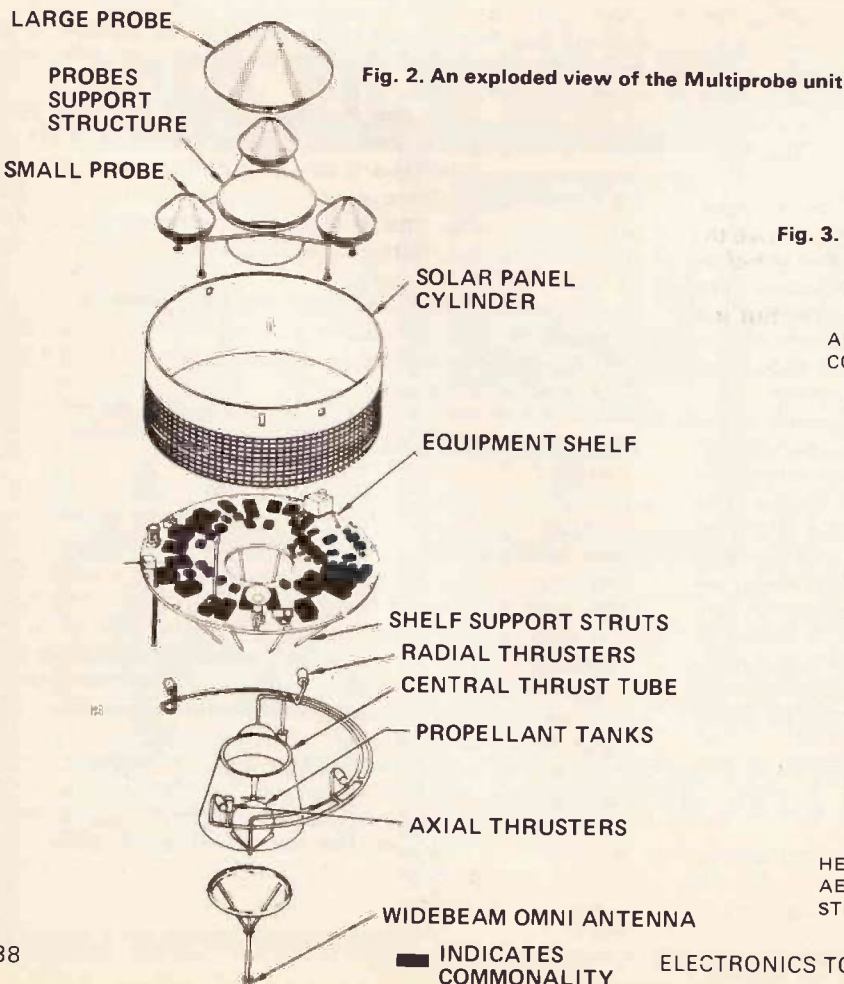

Fig. 3. The large probe with shield and pressure vessel

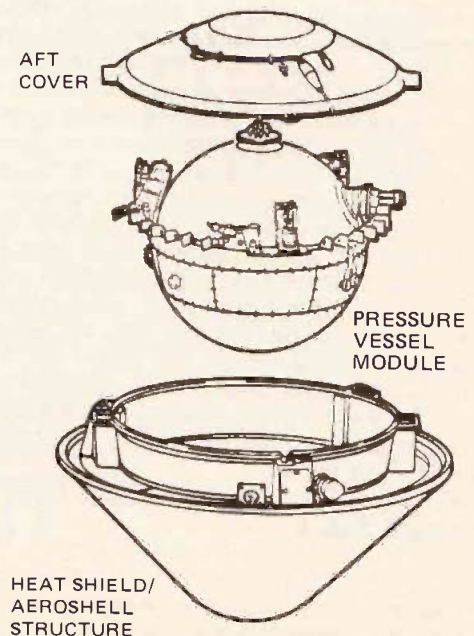

Fig. 4. An exploded view of the Orbiter spacecraft

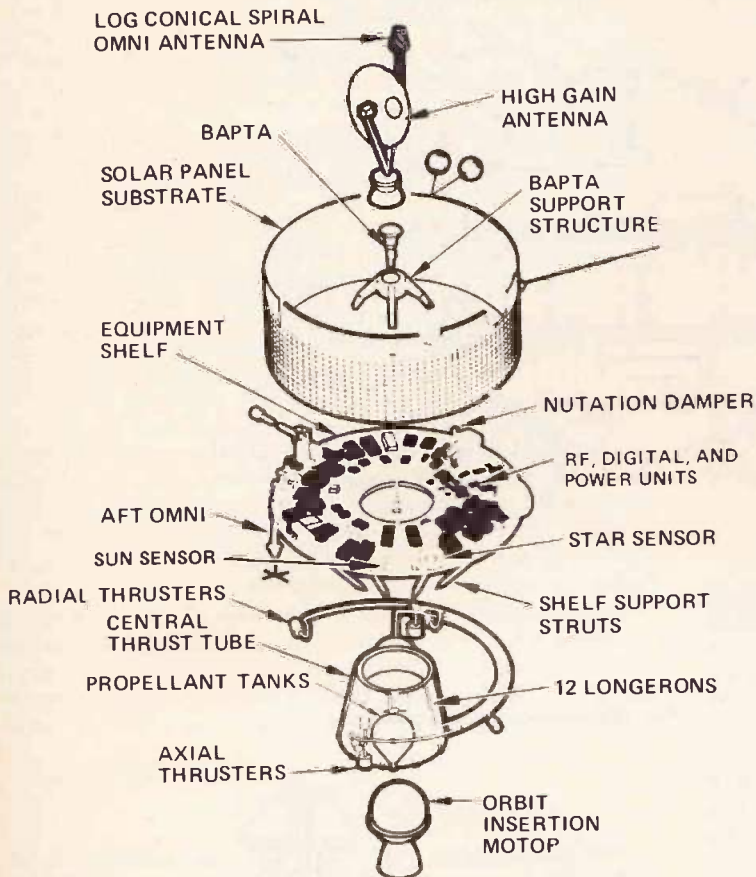
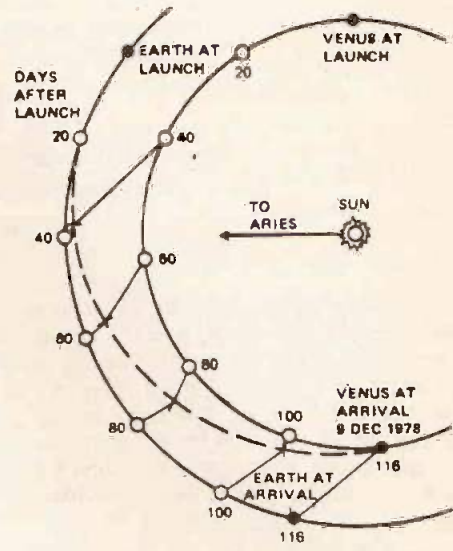

Fig. 5. Trajectory of the Multiprobe unit on its flight to Venus.



To Boldly Go . . .

The launching vehicle will place the multiprobe spacecraft into an earth parking orbit about 167 km above the earth where it will remain for 18 to 23 minutes before adopting the interplanetary trajectory shown. The spacecraft will initially be spinning at 5 RPM, but it is expected that contact with the ground station at Canberra will occur within four hours from launch and the rate of revolution will then be increased to 15 RPM by a command from the ground.

During the passage of the spacecraft towards Venus, the forward antenna will be employed to communicate with the 26 metre diameter dish aerials of the Deep Space Network. A velocity correction of up to 12 m/s can be made five days after launch and further corrections at 20 days after launch, etc. Command signals for these corrections will be transmitted from one of the huge 64 metre diameter earth station aerials.

The large probe will be separated from the Bus about 24 days before arrival at Venus. The spacecraft axis will then be precessed so that the medium gain horn can be used for earth communication. A velocity correction of 5.1 m/s will be made to achieve the required small probe trajectory and the three small probes will be released about 20 days before reaching Venus. The spin rate will have been previously increased to 48.5 RPM so as to provide a suitable tangential velocity at separation for the small probes to acquire the desired trajectory.

The velocity of the Bus will be corrected 18 days before its arrival at Venus to achieve the desired arrival point and to delay its arrival by 90 minutes so that all of the probes will have impacted on the surface of the planet by the time the Bus arrives in the upper atmosphere. Burn-up will occur at some 120 km above the planet.

All five vehicles will enter the atmosphere in a two hour period and all will be transmitting simultaneously, so the time of entry will be arranged to be one at which two of the Deep Space Network stations can simultaneously receive signals to avoid possible loss of data.

Large Probe Mission

The large probe is to be aimed at a point on the daylight side of Venus, decelerations of up to 400 g being possible at times during entry. The large probe parachute opens at a height of 67 km and for the next 18 minutes the probe descends under the stabilising influence of the parachute to a height of 46 km at which point the parachute is jettisoned. The probe then falls to the surface of the planet over a period of some 38 minutes.

The probe is not required to survive impact with the surface of the planet, but will withstand the pressure and temperature at the surface. This requirement together with the requirement that the probe can withstand the fierce acceleration presents many design problems unique to this mission. ▶

Fig. 6. The interior of the large probe

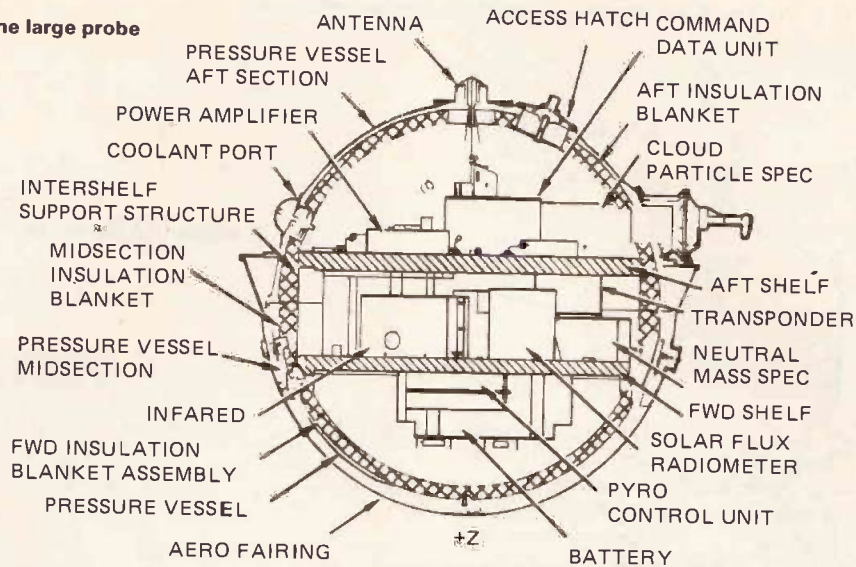

The large probe and its deceleration module have a total weight of some 316.6 kg. The deceleration module provides thermal protection during atmospheric entry; it consists of a pointed nose cone of 45° angle with a diameter of 1.42 m. The base of the probe is thermally protected by a coated fibreglass aft cover.

The dacron main parachute has a diameter of nearly 5 m and is deployed by a much smaller pilot chute 0.76 m in diameter ejected by a mortar. The pull of the parachute extracts the pressure vessel module from the deceleration module.

Pressure Vessel

This vessel contains nitrogen at a pressure of between about 0.5 and 2 earth atmospheres, but can withstand an external pressure of about 100 atmospheres. The 73 cm diameter titanium pressure vessel is constructed in three pieces and is about 6 mm in thickness. There are 15 apertures and 7.6 m of sealing are required to prevent gas leaks at the high temperature of the Venusian surface. The thermal insulation ensures that the electronics and instruments inside this vessel remain at a temperature not greater than 50 C even when the external temperature reaches 480 C.

A 19 cell 40 A-hr silver-zinc battery supplies power to the pressure vessel assembly. A total of 15 magnetic latching relays provide on/off control, whilst parallel fuses provide overload protection. Four solid state amplifiers, each rated at 10 W, feed a cross dipole antenna mounted on the rear of the pressure vessel which sends the data back to earth. A data rate of 128 or 256 bits/sec in a convolutionally encoded format is used, the system being capable of providing 72 data channels and 2 minor frame formats in an 8-bit word, 64 word frame. A 3072 bit memory provides storage facilities during the entry communications blackout; this blackout will have a duration of about 10 seconds.

The entire sequence of 128 commands is predetermined and programmed prior to the multiprobe launch. A timer with a 24.27 day capacity and a stability of ± 32 seconds turns on the system prior to entry.

Fig. 7. The interior of a small probe

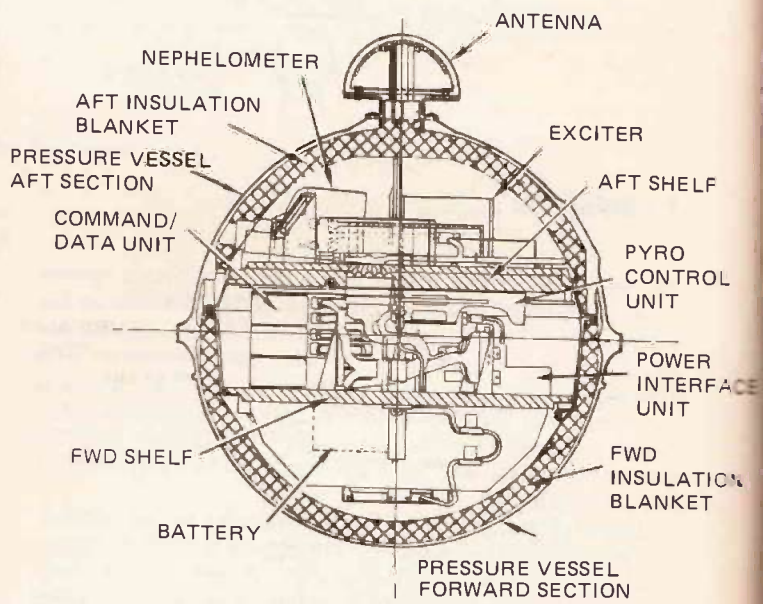

The seven scientific instruments in the large probe weigh a total of 35 kg and require 106 W for their operation. Three of these instruments require inlets for sampling the atmosphere and four require windows for viewing the atmosphere. All of the windows except one are made of sapphire, the exception being the window for the infra-red instruments which is a 13 carat diamond nearly 2 cm in diameter; diamond is the only material able to transmit infra-red in the 10 micron region and to withstand the temperature and pressure at the Venusian surface.

The Small Probes

The three identical small probes are designed to measure the characteristics of the Venusian atmosphere simultaneously at three widely different locations. They are designed to withstand the high temperature and pressure at the surface of the planet, but need not necessarily withstand the impact with the surface. During entry into the atmosphere at a speed of about 11.6 km/s, a deceleration as great as 5652 may be encountered. The time of descent to the surface will be about 59 minutes.

Each small probe contains a pressure vessel and a deceleration module. The total weight is some 97 kg. Unlike the large probe, there is no parachute with each small probe and the deceleration module is not detached during descent. The cone of the deceleration module has a diameter of some 76 cm.

The small probe pressure vessels which contain the electronics and the instruments are designed to operate with an internal atmosphere of xenon at between 0.25 and 2 earth atmospheres pressure. These vessels consist of a two piece titanium shell of about 46 cm diameter.

The small probes are each powered by a battery containing 20 silver-zinc cells with an 11 A-hr rating. Each probe employs a single, solid state power amplifier rated at 10 W RF output; this amplifier feeds a crossed dipole antenna mounted on the rear of the pressure shell. A stable oscillator maintains the S-band downlink frequency to 1 part in 10^9 . The data rate used from the small probe to earth is 16 or 64 bits/second, whilst a

Fig. 8. A small probe

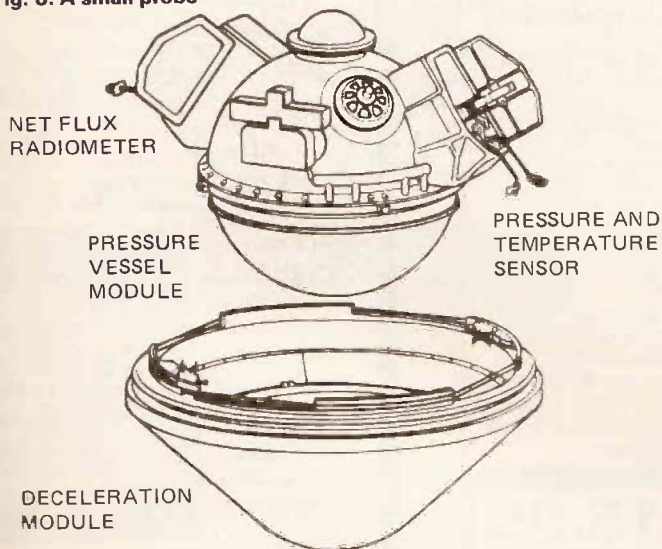

3072 bit memory is used for storage during entry blackout and when the bit rate is being changed. A 24 27 day timer turns on the system prior to entry into the Venusian atmosphere.

The 64 bit/second data rate is used initially, but at an altitude of some 30 km above the surface the data rate is reduced to 16 bit/second to allow for the attenuation of the radio frequency signal as it passes through the denser parts of the Venusian atmosphere.

The Orbiter craft. Note the long magnetic probe to measure the magnetic field well away from any interfering field from the craft.

The Orbiter Mission

The main aim of the Orbiter mission is to put 12 scientific instruments in orbit around Venus and to receive information from these instruments. It can be seen that the Orbiter spacecraft has much in common with the multiprobe vehicle, including a rather similar structure. Some of the most noticeable differences are the replacement of the probe structure by a high gain aerial system which can provide communication with the earth at distances of up to 250,000,000 km. A 4.5 m long magnetometer boom is also used in the Orbiter craft.

The size of the Orbiter spacecraft is similar to that of the multiprobe craft. The diameter of the cylinder of solar cells is the same 2.54 m, but the surface area of the cells is greater, being almost 7.2 m². The Orbiter is lighter than the multiprobe unit, being just under 600 kg and only 372 kg in orbit.

The slightly large solar cell area of the Orbiter provides a little more power than in the case of the Multiprobe Bus, this power being about 325 W in Venus orbit. Two 7.5 A-hr nickel cadmium batteries are also incorporated in the Orbiter spacecraft.

A bearing and power transfer assembly (BAPTA) serves an electrical and mechanical interface between the spinning part of the spacecraft and the despun aerial which must always point towards the earth. As in the case of the multiprobe Bus, 32 kg of liquid Hydrazine propellant is carried in two tanks and can drive seven jets, each with a thrust of about 0.5 kg, for the control of the trajectory, attitude and spin rate.

A solid propellant rocket motor, the Thiokol TEM-604, is to be used to place the Orbiter in Venus orbit. It has a velocity change capability of 1060.6 m/s for the maximum design weight.

Conclusion on Cost

A special feature of the Pioneer missions is the relatively low cost for such an ambitious programme. In order to reduce the cost, no experimental prototype craft have been built — only the one multiprobe and the one orbiter will be made, tested and orbited. Economies have also been made by using the same type of components (such as the RF amplifiers) in the Bus, Orbiter and in the probes. Identical command and data handling circuits are used in all of the probes, whilst about 78% of the Bus and Orbiter parts are identical. The cost of developing the probes themselves has been relatively high, since they involve new techniques, whilst special facilities have had to be developed to simulate the hostile Venus atmosphere.

It seems likely that craft similar to the Pioneer type will be useful for relatively economical missions to Mars and for flying through the tails of comets.

ETI

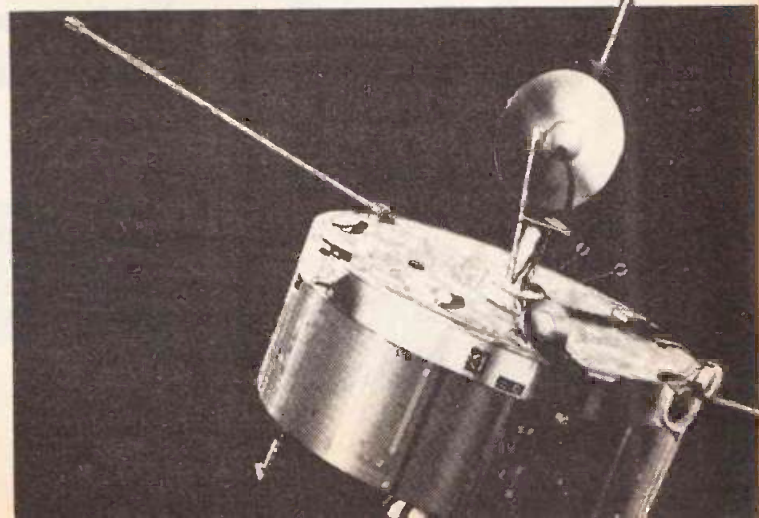

Now, from the breadboard specialists— even better boards!

Since the appearance of the first breadboards back in the '40's, we've really been going places. (The U.K., for one.) So we now have an exceptional range of prototyping products which are outstanding in their simplicity, versatility and reliability. Just see. (And for prices and specs., eyes left!)

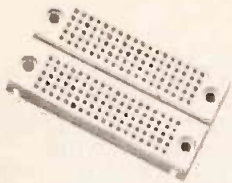

1 Experimentor Series.

Low-cost, interlocking, solderless breadboard — the world's first for 0.3 in. and 0.6 in. pitch DIPs.

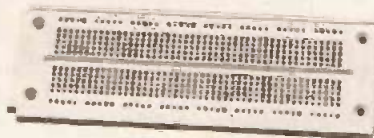
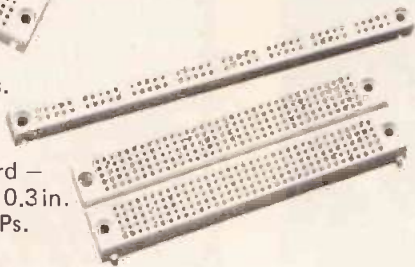

2

Quick Test Series.

Low-cost, snap-locking solderless circuit boards for fast design with discrete components.



3 The Protoboard Series.

Solderless breadboards with built-in 10% regulated 5Vd.c. 1A power supply; 2,250 solderless tie points; and capacity for DIPs of 14 to 40 pins.



Take a look at our low, low prices and quality specs., and get aboard! (Or if its data you're after, pick up the phone or drop us a line.)

For the best, from the specialists in breadboards.

4

Design Mate Test Instruments.

DM-1 power supply, 5V to 15Vd.c. at 600mA; DM-2 function generator for sine, square and triangle wave generation; DM-3 R/C bridge giving 10 ohm to 10 megohm, 10pF to 1.0µF; DM-4 pulse generator with 0.5 Hz to 5MHz frequency and 100ns to 1 sec pulse widths.



5 IC Test Clips.

Ultra-low cost IC clips in 14, 16, 24 and 40 pin versions.

And, much more too: logic monitors, probes, frequency counters and test equipment to ensure the best, fastest results from your design.



Continental Specialties Corporation (U.K.) Ltd., Unit 1, Shire Hill Industrial Estate, Dept. 9H
Saffron Walden, Essex. CB11 3AQ Telephone (0799) 21682 Telex 817477 Reg. in London: 1303780.
VAT No: 224 8074 71. *Trade Mark applied for © CSC (UK) Ltd. 1977 Dealer enquiries welcome.

Please supply _____

Price _____ Total _____

Name _____ Address _____

My cheque/postal order No _____ for £ _____ is enclosed

My Access/American Express/Barclaycard no. is _____ All I want is data, please.

We're on Stand B1
at the Breadboard
exhibition.

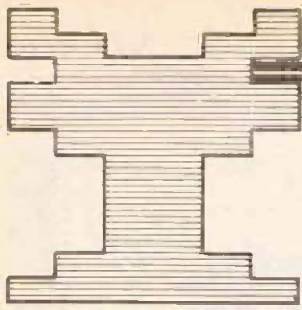

TELEVISION

Last month we described the operation of the Tolinka chess recorder — this month we deal with construction.

LAST MONTH WE described the overall principles of the Tolinka Chess Recorder and in this final part of the project we shall describe the circuit from the hardware viewpoint and go on to give constructional details.

First inspect the board on both sides to see if any of the holes have been blocked by tinning. The easy way to clear such holes is to melt the solder and apply the sharp point of a pencil. Wipe the iron frequently on a damp sponge or cloth to avoid solder splashes.

A Small Step

The first step in construction is to make the through board links support the board 4mm approximately away from the bench surface by putting bolts in the corner holes. The side without the IC pads should be uppermost. Each of the small round pads which has a counterpart on the opposite side of the board is a pin-through whereby connection must be made through the board. A piece of wire must be inserted into each of these holes and soldered on both sides of the board.

The board should now be cleaned of flux with a cleaning agent and inspected against a strong light. Look for missed pin-throughs, solder bridges and lifted tracks checking with a continuity meter any suspected opens or shorts. Spend a lot of time at this stage because this is where faults are most likely to exist—it is possible for another observer to find obvious faults on a board which has passed a lengthy examination.

The ICs are inspected next.

Socket It To Me

Use the socket strip provided for any IC with more than 16 pins. The best way of socketing an IC is to push the pins into the socket strip and then trim off the surplus strip. Do not break off the pin carrier part of the strip until you are ready to switch on the power. This will keep the IC pins shorted together during the soldering

and assembly process. If desired socket strip or sockets may be used for the other ICs—and this is a wise precaution.

It is recommended that components be installed in the following sequence—first all discrete parts like resistors, capacitors and diodes; next integrated circuits and last the larger power supply capacitors and voltage regulators. Switches need not be installed until preliminary tests are completed and installation of the PCB behind the front panel has been carried out. The panel then forms a template which aligns the switches correctly.

Remember that the space above the board is limited and solder any bulky components beneath the board: this is certainly necessary for the power supply electrolytics. Leave the output pins of the voltage regulators unsoldered so that supplies may be checked without damage to the circuitry. Note that the power supply components are soldered directly to the tracks on the top of the board and only the wires of the electrolytics pass upwards from the underside of the board through holes. All voltage regulators are 'face down', the main 5 volt supply regulator being bolted to an area of circuit board which acts as a heat sink.

Testing Time

Turn on the mains and test power supply voltages before soldering the regulator output pins down to the supply rails. Remove all ICs from their sockets and break off the pin carriers. Test voltages on supply rails again with the rails connected—do not of course fail to switch off the mains between tests. If all is well then instal the ICs and check the rails again.

Tune the TV set to receive a picture. There will be more than one picture available in the tuning range

and the best one should be found. If the picture has chessmen set up for the start of a game and move status information is correct then the printed circuit board may be installed beneath the lid of the box with the nuts, bolts and spacers provided and the keyboard switches soldered in place. If the device now functions correctly then attention may be turned to the cassette interface.

In an ideal world you could buy audio equipment which had standard sockets using standard signal levels at a standard impedance. This you could connect together with standard leads. The manufacturers of our world do not see things that way, however, and they make equipment with sockets, signal levels and impedances which are different from those of their rivals.

It will therefore be up to you, to decide upon these things as far as your own tape recorder is concerned. You might become involved in designing an attenuator to get things working properly. If you do not know how to do this and do not feel confident after reading the general remarks which follow, perhaps you really ought to be playing at something else.

The Ins and Outs

Outputs vary from millivolt level for a 5 pin DIN socket, but could be only available on a microphone input and earphone output. If inserting a plug into the socket cuts out the internal speaker the cutout switch should be disabled—try bridging it with a 33 ohm resistor. It is essential to hear the data and commentary.

(Input/Output can be the same pin) It may be that volume and tone controls have an effect on the output signal but this is not usual.

Inputs vary from millivolt level for a dynamic mike to a high level—sometimes marked AUX. The high level input should be used if

CHESS

PART 2

available. The signal must be attenuated for a low level input to avoid overloading. Most recorders have Automatic Volume Control and this helps. The output from Tolinka is bursts of 3.9kHz at the data rate, which is 300 baud—or 150Hz maximum. Every high bit generates 12 cycles approximately of the carrier. The main source of interference may be regarded as being the data rate itself and some sort of high pass filter is needed at the input and output to remove it. Attenuation may also be required to match the recorder's input characteristics. A series capacitor followed by a shunt resistor will perform both these functions and in some cases even the shunt resistor is not required—it depends upon the recorder's input impedance.

If an oscilloscope is available the recorder's output may be observed and should consist of clean bursts of 3.9 kHz separated by level blank intervals. If the signal swings up and down with the data the recorder is receiving too much signal and the shunt resistor should be reduced until this effect disappears. This process should not be carried to the point where the output level is reduced.

If in doubt use the following rules of thumb:

- Put a 10k pot between the output and ground, taking the signal from the slider. Reduce the input level until the sound loses volume on playback.
- Take the output from the earphone or headphone socket. This will almost certainly cut out the recorder's internal speaker, but the switch should be easy to find and bridge with a 33 ohm resistor as described earlier. Adjust volume on playback to obtain satisfactory RECALL function. Note setting of both controls and check this setting each time.

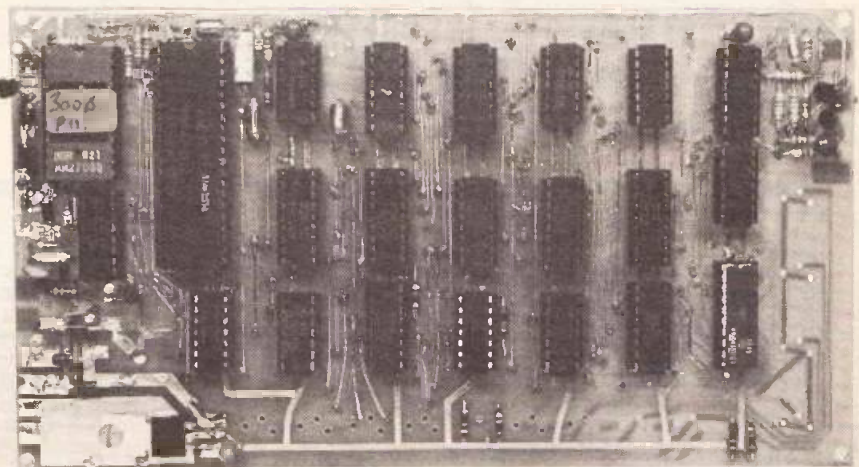

Photograph of the circuit board taken during construction. The switches are not fitted until the board is ready to be mounted in the case — Initial testing being done without them in position.

One of the exclamations often heard at a Chess Congress is 'J'Adoube' which is not a Russian four-letter-word but a polite way of informing one's opponent that a piece is not situated in the centre of the square it is supposed to be occupying;—and this fact is bugging the exclaimer who intends to adjust it but does not wish to be committed to moving it subsequently according to the rules of the game.

Tolinka has provision for moving

the pieces into the exact centre of their squares, the 'J' ADOUBE' capacitor. This component (C5) loads one of the outputs of a binary counter introducing a propagation delay which is passed down the divider chain. The value mentioned in the parts list is satisfactory for all but the most neurotic. In order that centralization may be optimized provision has also been made to fit a resistor for fine adjustment which will explain two of those redundant holes

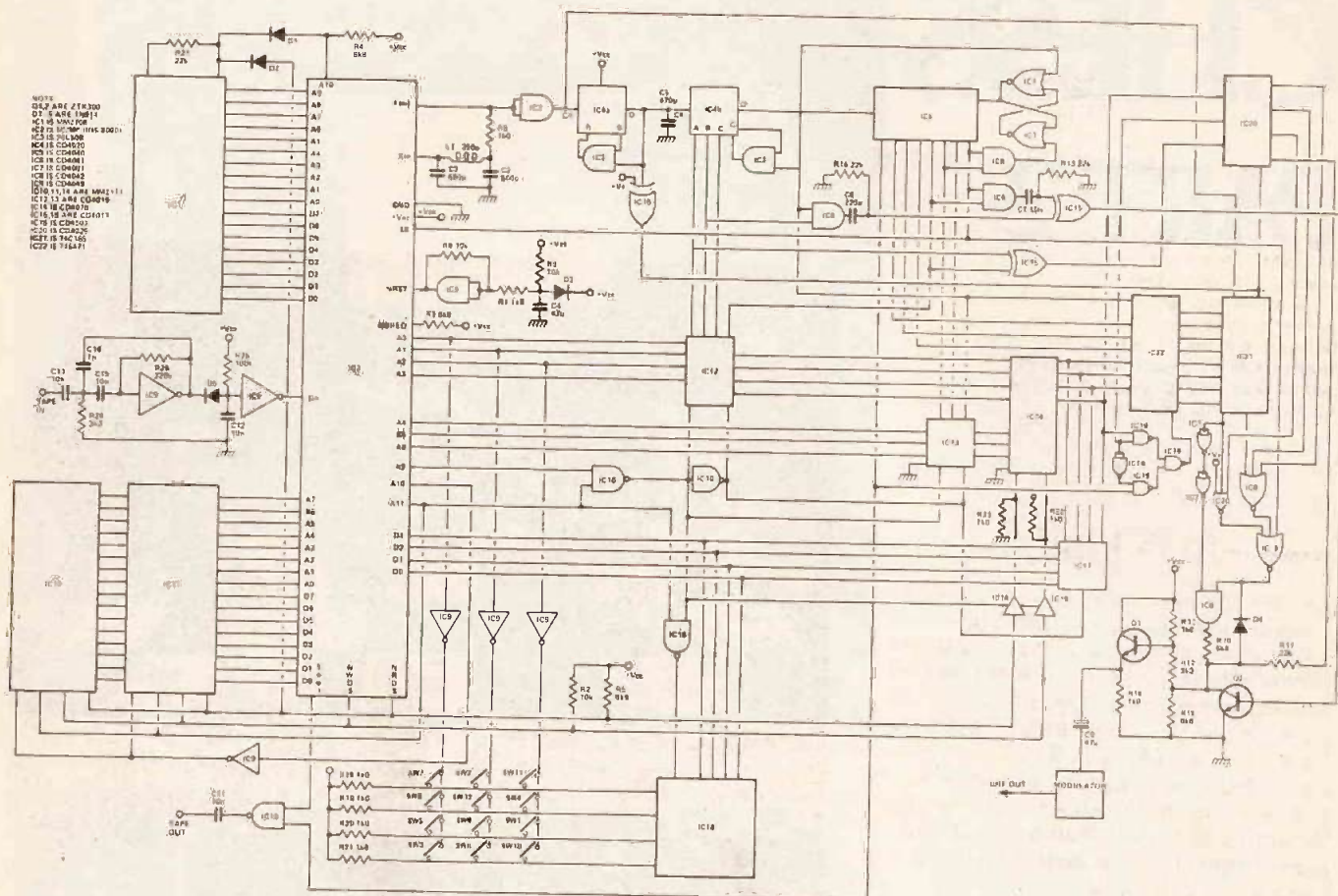
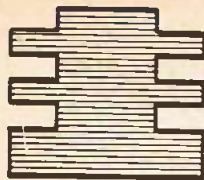

Fig. 1 Main circuit diagram of the Tolinka.

IC2 is National Semiconductor's SC/MP II. Its Program memory is stored in a 2708 type EPROM (1024 bytes). The character generator PROM (IC22) is a 74S471, 256 x 8 in structure. The RAM chips are 2111s, two (IC10 and 11) for game memory and one (IC14) for on-screen information. (There are 8 bits in game memory but only 4 in screen memory.) Top locations in game RAM are used as temporary stores for other information and this restricts the number of moves per player to 62 instead of 64 (four bytes are required to store a move).

Screen RAM is normally addressed by the VDU divider chain's outputs but the MPU must be able to address the screen as well to move the pieces around and change the status information. The address lines are multiplexed through a pair of CMOS And/Or gates (IC 12 and 13). The vertical blanking signal is wired to a sense line of the MPU so that the MPU does not access the screen during the VIDEO INTERVAL which would produce annoying flicker.

The three lowest address lines of the MPU are connected to inverter gates (ICXX) which matrix the keyswitches in a three by four arrangement. Pressing any switch connects an inverted address line signal to one of four inputs of a tri-state buffer normally held high by a resistor (R18-21) to Vcc. When the buffer is selected the inverted address line may be read as data and the switch identified with a unique code by a process already described in the Software: How it Works.

Generation of a Video Signal

All frequencies used are derived from a single MASTER CLOCK which is the MPU's own on-chip oscillator. An L/C combination sets the frequency to 1.92 MHz which defines the shortest horizontal change interval on screen at about half a microsecond. The MASTER CLOCK is divided by ten (IC4a) to give the FILE interval. Eight FILES form the visible board but the FILE interval is divided by twelve in a four-stage binary counter. The A, B & C outputs of this counter are the LETTER addresses, the D output being the LINE BLANKING interval. Thus two-thirds of linescan are the chessboard.

During LINE BLANKING a R/C monostable (C18, R14) supplies the LINE SYNC pulse. Further division of the line interval by 32 gives the RANK interval which is taken from the 5th stage of a binary ripple counter (IC5): the 2nd, 3rd, 4th & 5th outputs of this counter being the address lines to the character generator PROM. This PROM supplies the horizontal piece information as eight outputs in parallel and changes this information every other line. The 6th, 7th & 8th outputs of the ripple counter are the FIGURE addresses. The 9th output is the FIELD BLANKING pulse which is 'Anded' with the 7th stage to reset the counter after 320 counts. 256 counts, or lines, are visible as the chessboard. During FIELD BLANKING monostable (C7, R13) supplies the FIELD SYNC pulse.

LINE BLANKING is also connected to the character generator PROM to select Status Figures presentation instead of chess pieces. The same LINE BLANKING signal also permits the 4th output of the Board RAM, which contains the COLOUR BIT during the Chessboard interval, to address the character generator PROM instead of the 2nd output of the vertical binary ripple counter. (The COLOUR BIT is normally 'Exclusive-Or'd' with the pieces during the Chess board interval to control their colour.) This is because the larger character set of Status Figures symbols are required than Chesspieces — and loss of vertical resolution (cut by half) is the price which must be paid.

The eight parallel outputs of the character generator PROM are converted to a serial data stream in the Video Shift Register (IC21), driven by the MASTER CLOCK and loaded by the FILE signal.

SQUARE COLOUR is derived from RANK and FILE by Exclusive-Or function. SQUARE COLOUR, LINE BLANKING and COLOUR BIT are aligned with SERIAL VIDEO by a D type Flip Flop clocked by FILE.

LINE SYNC and FIELD SYNC are also passed through an Exclusive OR gate to form MIXED SYNC.

SERIAL VIDEO is combined with COLOUR BIT, LINE BLANKING, FIELD BLANKING, etc. to form two mutually exclusive signals WHITING and BLACKING.

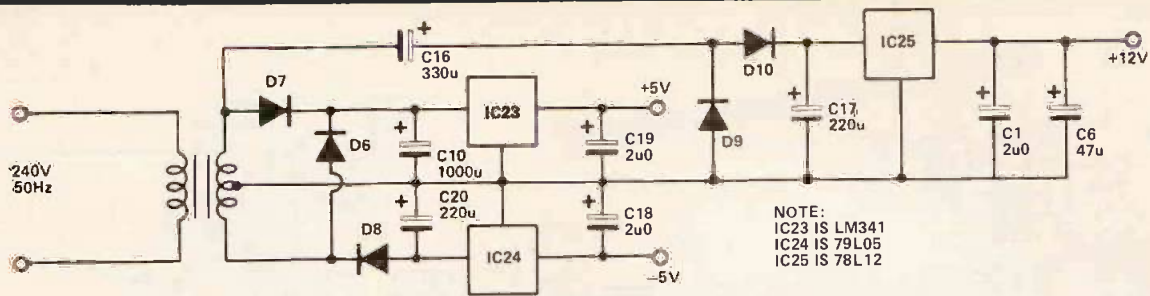
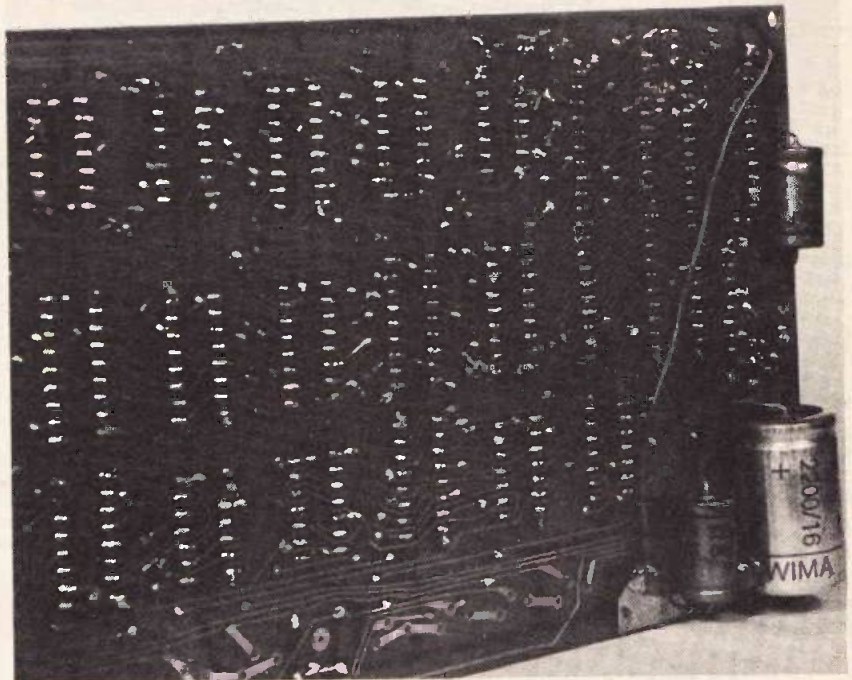

Fig. 2 The Tolinka's power supply is a straightforward design based on three monolithic regulators.

The photograph right shows how the power supply capacitors are mounted beneath the board and the wire link. Note that this photo was taken before the board was complete and not all components are in position.



BUYLINES

A complete kit of parts for this project will be available only from Videotime Products, 56 Queens Road, Basingstoke, Hants, RG21 1REA for the all inclusive price of £109.50.

Individual parts are also to be made available but Videotime will offer help, advice and a repair service only to readers who purchase the complete kit. Note also that software, piece design PCB pattern, etc, are subject to copyright.

HOW IT WORKS

Forming a Video Composite

The video signal is formed by combining SYNC, SQUARE COLOUR, WHITING and BLACKING at a summing point. SYNC is connected to Q2 which clamps the summing point (junction of R10, 12 and 15) to ground when SYNC is high. BLACKING is a negative going signal connected to the summing point through diode D4: when BLACKING is low the summing point is clamped a diode drop above ground. WHITING pulls the summing point up towards the positive rail through resistor R1 and supplies two shades of grey when no other signal is present.

The signal is attenuated and passed through an emitter-follower to form a low impedance standard form video signal of approximately 1 volt peak to peak. This signal is used to drive a UHF modulator.

The reason that the SERIAL VIDEO output of IC21 is passed through a couple of inverter gates is to equalize propagation delays. Otherwise the black pieces have white edges.

Cassette Interface

The limited bandwidth available in audio cassette recording equipment does not permit serial data to be recorded directly. Some form of modulation is required.

In Tolinka data is recorded as bursts of a single frequency. On playback other frequencies can be filtered out and the demodulation process performed with a diode.

Three CMOS gates are used as the Modem in the final design. Any CMOS inverter will operate as a linear amplifier if a resistor is used between input and output. In this condition it may be regarded as an Op-Amp which has its non-inverting input connected to ground. A limited voltage gain of about 60 is available. The output data comes from the serial output port of the MPU and is combined with a signal of 3.9 KHz from the VDU divider in an AND gate. This supplies bursts of 3.9 KHz at data rate which can be recorded on tape.

The recovered signal is filtered by a CMOS inverter configured as a high pass filter. This rejects low frequencies at data rate and in the speech band. The output of this inverter, which consists of high amplitude bursts of 3.9 KHz, is connected to the cathode of D5. The anode of D5 is taken to the input of another inverter and a low pass filter, consisting of a resistor (R26) to the positive rail and a capacitor (C12) to ground. Gates in the same package have similar transition points — so when there is no input the output remains at ground level. If 3.9 KHz oscillations are present at the input the output is high. The demodulated transmission is fed to the MPU's serial input.

Power-on Reset

The MPU has a Reset input which clears all internal registers and restarts operations with the first instruction after it has been brought low for a specific interval of time. This function occurs when Tolinka is first switched-on and is not required again by the user.

At first sight this circuit seems to be oversized. In fact correct initiation of proceedings is vital and reliability suffers if any of the components are omitted. The diode connected across the charging resistor ensures that the capacitor will discharge if the power is interrupted only briefly.

ROM Select Diodes

The ROM occupies the first kilobyte of addressing space and it would seem logical to connect its Chip Select input directly to A10 because no write instructions will be made in this area. Conflict would still take place because the MPU outputs data on the bus at the start of the instruction fetch operation — this data consists of flags and upper address bits and none of it is used by Tolinka. The conflict would be harmless but for the fact that a Video Signal is being produced and processed at the same clock rate as the MPU which produces a faint pattern on screen if the Chip Select diodes are omitted.

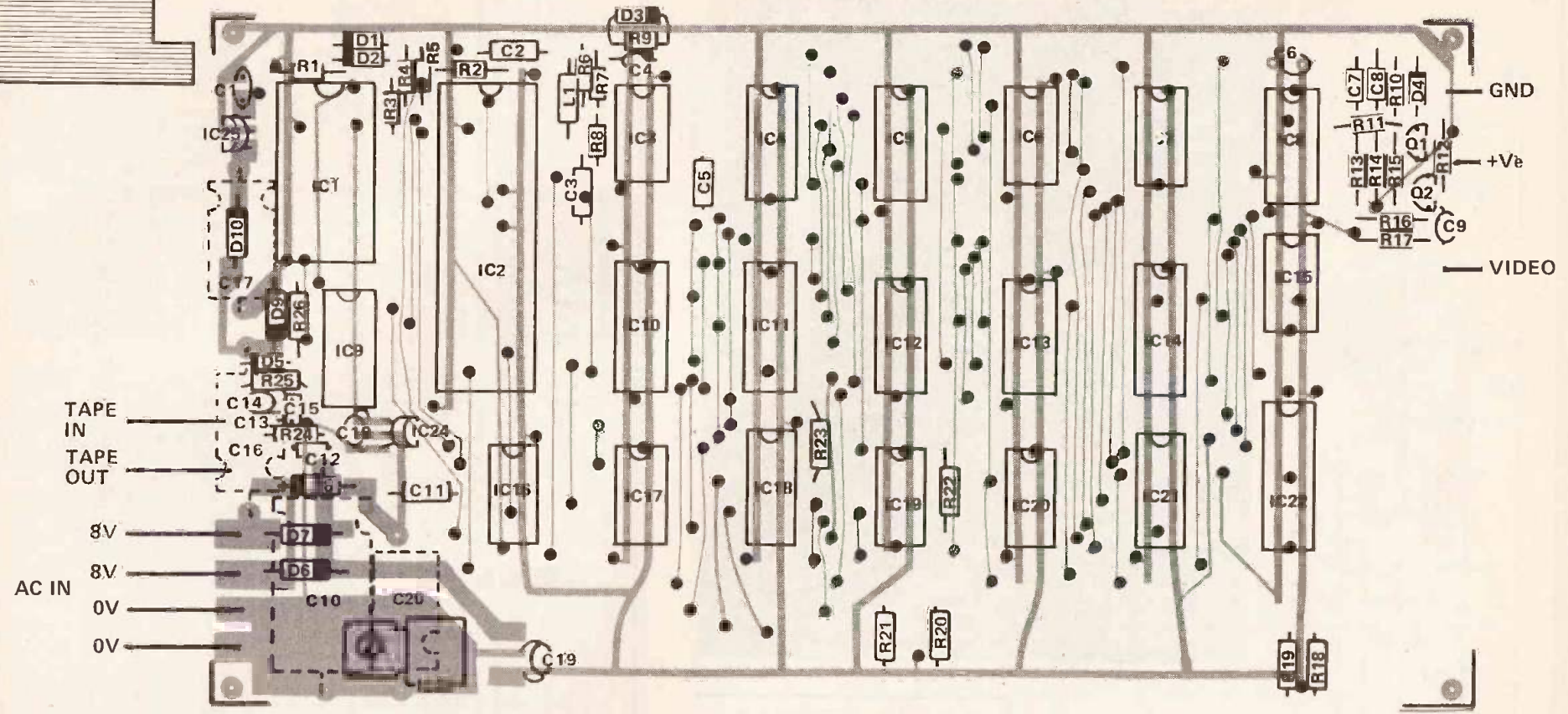

PARTS LIST

RESISTORS		C3	680p polystyrene	IC4	CD4520	IC24	78L12
R1, 11, 13, 14	22k	C4, 6, 9	47u 6V3 tantalum	IC5	CD4040	IC25	79L05
R2, 8, 9, 18, 19, 20, 21, 22, 23	10k	C5	470p polystyrene	IC6	CD4081	Q1, 2	ZTX300
R3, 4, 5, 10, 15	6k8	C7, 11, 12, 13, 15	10n ceramic	IC7	CD4001	D1-5	1N914
R6, 7, 16, 17	1k0	C8	220p polystyrene	IC8	CD4042	D6-10	1N4001
R25	220k	C10	1000u 16V elec-trolytic	IC9	CD4049	INDUCTOR	
R26	100k	C14	1n0 ceramic	IC10, 11, 14	MM2111	L1	250u
R12, 14	3k3	C16	330u 16V electrolytic	IC12, 13	CD4019	MISCELLANEOUS	
CAPACITORS		C17	220u 16V electrolytic	IC15	CD4070	PCB, transformer (0-8; 0-8 at 500mA), UHF modulator, switches (Schoeller- 12 off), case to suit, sockets, cable, nuts, bolts etc.	
C1, 18, 19	2u06V3 tantalum	SEMICONDUCTORS		IC16, 19	CD4011		
C2	560p polystyrene	IC1	MM2708	IC17	CD4066		
		IC2	INS8060	IC18	CD4503		
		IC3	74LS08	IC20	CD4025		
				IC21	74C165		
				IC22	74S471		
				IC23	LM341-P5		



Just one of many kits in the New Hobbies catalogue

The new Doram Electronic Hobbies Catalogue is packed full of new exciting merchandise including

MICRO PROCESSOR BASED KITS.

ELECTRONIC KITS FOR ALL THE FAMILY

ELECTRONIC TOOLS AND BOOKS

AUDIO & CAR ACCESSORIES ETC.

Send for your copy now.

(AVAILABLE LATE SEPT)

Overseas customers (except for N. Ireland)—
60p including despatch by Air (or all-up post)

Doram Electronics Ltd
PO Box TR8
Wellington Road Estate
Wellington Bridge
Leeds LS12 2UF

DORAM

ELECTRONIC HOBBIES CATALOGUE

Name

Address

Please send my FREE Hobbies Catalogue. I enclose 25p. contribution to p. & p.

Doram Electronics Ltd
PO Box TR8
Wellington Road Estate
Wellington Bridge.
Leeds LS12 2UF

ETI 7





'TOLINKA' CHESS REPORTER — FULL KIT OF PARTS

The original unit used in conjunction with the World Chess Championship at Manilla, August '78, by both Chess Champion Viktor Korchnoi and BBC TV news.

Records every game step, auto en passant, queening and castling. Entire games may be recorded on most domestic cassette recorders. Based on 8060 Mk II Scamp. Full kit including all components — No extras required — **£109.50***



'ATARI' VIDEO COMPUTER — READY BUILT CARTRIDGE SYSTEM (ROM)

Designed and built by Atari (part of Warner Comms) in the USA this unit is the most advanced centre available

Just look at a few of the cartridges (up to 50 games each) available in full glorious multi-colour and very realistic on TV Sounds

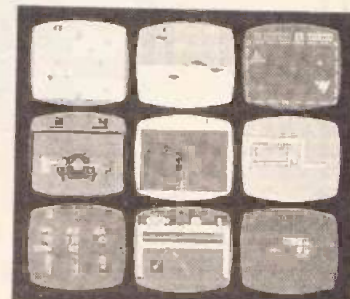

Examples of some of the many cartridges available: Combat, Air Sea Battles, Space War, Outlaw, Video Olympics, Surround, Black Jack, Breakout, Basic Math

The Video Computer (based on Signetics 2650) comes complete with 27 Game Combat Cartridge (tanks, bi-planes, bombers, jets), 2 joysticks, 2 rotational controllers, mains adaptor and aerial switching unit. Fully guaranteed for 12 months. **£169.95***
Additional Cartridges (over 21 due by early '79) mostly priced at **£14.95***

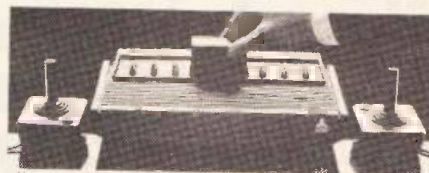

Full Colour Brochure available on request

UNBELIEVABLE WATCH BARGAINS



VT01
5 FUNCTION
LCD. Hour, Min, Sec.
Month, Date, S/S strap,
Backlight.



VT07
12 FUNCTION
CHRONOGRAPH
Hour, Min, Sec., DATE,
Month, 1/100th Sec. Time,
1 or 2 Event.

ONLY
£13.95*

VT03
SOLAR ALARM
Hour, Min, Sec, Month,
Date, Day, alarm any time
in 24, hour day.



ONLY
£25.95*

VT04
SOLAR
CHRONOGRAPH
As VT02 but with solar
panel



ONLY
£25.95*



VT05
CHRONOGRAPHY/
ALARM
All the combined features
of alarm & chronograph
watches
(photo
represents
case style only)

ONLY
£37.95*



VT06
ALARM/STOP WATCH
CLOCK
& Snooze Alarm, Stop
watch.

ONLY
£17.95*

Presentation boxes not included. Please add 65p

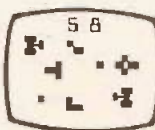

BARGAIN TV GAMES KITS AND COMPONENTS



Stand Alone Kits

Kits — full instructions, all PCB components. Mini-kits — instructions, chip, skt, coil, PCB

	kits	minikits
B&W Tank Battle (AY-3-8710)	£15.90	£9.75
B&W Stunt Rider (AY-3-8765)	£15.90	£9.95
B&W Road Race (AY-3-8603)	£14.90	£8.50
B&W 10 Game B/B (AY-3-8610)	£13.90	£8.50
NEW B&W Submarine (AY-3-8605)	TBA	TBA
B&W Wipeout (AY-3-8606)	£14.90	£8.50

Astec Modulators & Encoders

UM1263 Sound Osc	£1.95
UM1111 E36 UHF Mod	£1.95
UM1233 UHF (high quality)	£4.95
UM1168 Pal Encoder	£2.50
UM1163 Pal Enc + UHF Mod	£4.95
European Equivalents available	

Accessories

AB Joystick controls, 200k Ohm	£1.95
Crystal 4.4 Mhz	£1.00
Crystal 3.57 Mhz	£1.25
Oscillator coil 100µH	£0.45
Mains adaptor + 150mA 8v reg i/c	£3.50



* Prices include VAT, packing & delivery charges and money back guarantee. Send cheque or P.O. to

VIDEOTIME PRODUCTS 56 Queens Road, Basingstoke, Hants RG21 1REA
Tel: (0256) 56417. Telex: 858747.

(Trade & Export Enquiries welcome)



SWITCH IN LINE SAVES NONE?

Stan Curtis of Mission Electronics, author of our series on super-fi amp design is back with us again to explain the faults inherent in many widely used comparative hi-fi tests. In particular he has a few things to say about switching methods

A SIGNIFICANT RE-APPRAISAL of amplifier design has been seen in the past few years. The revival of serious listening tests (so called "subjective" testing) has shown that laboratory measurements alone are not sufficient to indicate the performance of the amplifier when it is connected to real loudspeakers and pick-up cartridges and fed with a music signal. But it is crucially important that these listening tests be set up with great care. When different amplifiers are compared their gains should be equalised so that their outputs are within 0.1 dB of each other and preferably within 0.05 dB.

Such level changes could be incorrectly interpreted as differences in amplifier performance. The design of the passive attenuators is important to prevent any significant loading of the circuitry or any unbalancing of impedances which could upset passive filter roll-offs and so alter the frequency response of the system. Even the choice of test signal is important when setting levels. Traditionally a sine wave of 1 Hz or 400 Hz has been used. However, the author prefers to use a noise source fed via a bandwidth limiting filter (to prevent any error by the different frequency responses of the amplifiers) as this more realistically simulates the dynamic conditions.

Care should also be taken in the interconnection of the different amplifiers. All connections should be as short as possible using very high quality and identical (in length and quality) cables. Wherever connections have to be made (other than at the amplifier or loudspeaker) high-quality gold-plated instrumentation connectors should be used in preference, to the rather suspect RCA Phono and DIN Connectors.

Switch Your Contacts

The next problem area is that of switching. Switching the outputs of the different amplifiers to a loudspeaker can be done using high-current, high-conductivity lever of knife switches. Relays can cause problems unless they have very strong springs; good contact design; high-current capability; and are new. The subject of switch contacts is quite complex but can be summed up as follows. A metal to metal contact is rarely a true "short circuit."

An almost invisible layer of oxidation or contamination forms on the contacts. This oxidation increases the contact resistance but more importantly forms a non-linear junction that can in some ways be considered to be a voltage dependent diode-rectifier. The effect on the

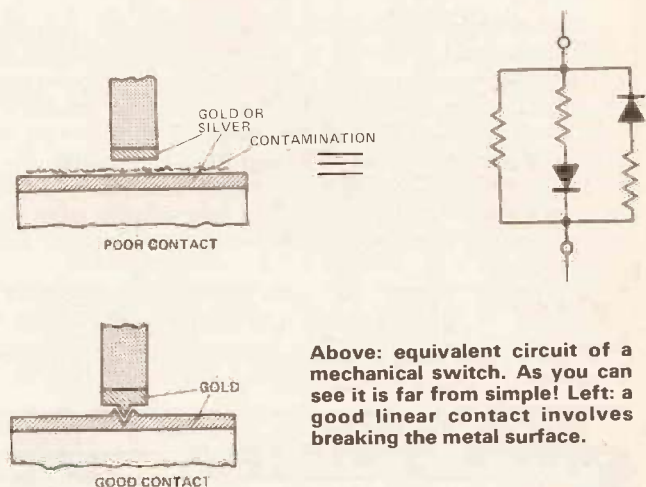

Above: equivalent circuit of a mechanical switch. As you can see it is far from simple! Left: a good linear contact involves breaking the metal surface.

music signal at low levels can be imagined and — more importantly — heard! Even "pure" gold contacts and "self-cleaning" contacts suffer from this problem. A good contact can only be achieved when one contact breaks the surface of, and penetrates, the other contact metal. However, only a limited number of switching actions can occur before the contact material is sufficiently worn or damaged for inconsistent performance. Although this problem is discussed here in relation to testing it has as much significance in the design of the switches used in the amplifier.

When it comes to switching the output of the cartridges the imperfections of the switches have so much effect upon the audible quality of the signal that the listening test ceases to have any real validity.

Test point

The test itself needs further thought. The listening panel should be experienced listeners and yet not be part of a "clique" where views are remarkable for the way they follow the "party line." Testing should be conducted over two or more sessions. Short sessions to perceive the performance of the amplifiers before aural fatigue sets in; and longer sessions with each individual amplifier to judge whether such fatigue is caused by the amplifier and to judge whether the apparent improvement it offered was a "flash in the pan."

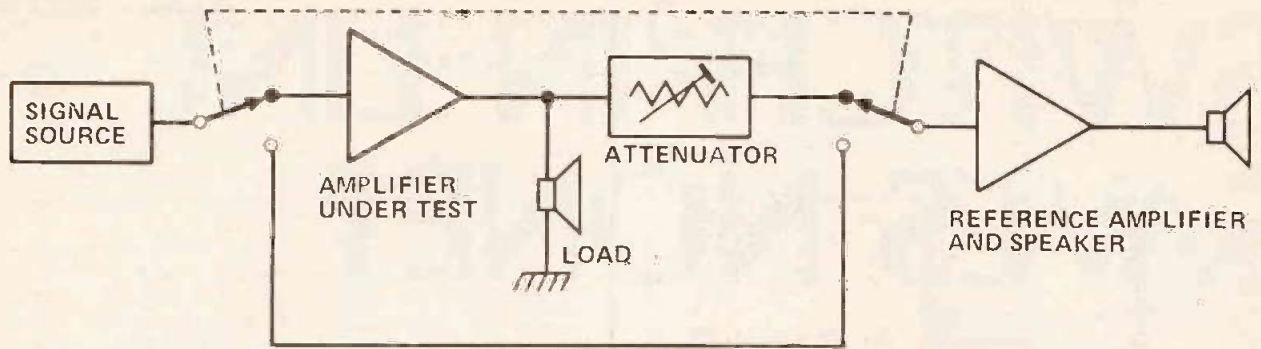

STRAIGHT LINE TEST

Fig. 2. The straight wire test. First popularised by Peter Walker of Acoustical Manufacturing (or Quad!) this test method has gained wider acceptance of late. It has its faults however.

During the initial sessions a number of "check" changes should be made to detect cheating (deliberate or involuntary) i.e. running amplifier No. 3 a second time as amplifier No. 7. Between each piece of music the reference numbers should be changed to minimise the effects of pre-conception. For example; if amplifier No. 3 is disliked for its reproduction of a bass drum, it may then be subconsciously disliked on other pieces of music. Of course the tests should as far as possible, be conducted blind.

A popular "subjective" test in use is the "Straight Wire Test." In this test the amplifier under evaluation is fitted with an attenuator at the output and substituted for a straight wire. The resulting signal is fed to a

"reference" amplifier and loudspeakers of known performance. Such a test is of help in evaluating the dependence of the amplifier on the loading made by different loudspeakers. But otherwise this test must be considered suspect. The "reference" amplifier may be far from perfect and it may well mask subtle changes. The dynamic interactions of two units in series can be quite complex and very difficult to predict in advance.

The foregoing (brief and incomplete) discussion of subjective testing serves only to indicate the difficulties that can be encountered. The reader should only consider seriously those comparative reviews where considerable effort has been expended to eliminate errors due to equipment and human beings.

ETI

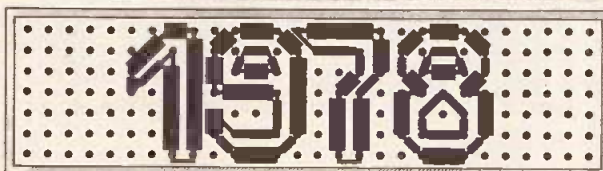

The kits & bits show for the home electronics enthusiast

Seymour Hall Seymour Place London W1

21-25 November 1978

Seventy stands packed with the gear that the home electronics constructor needs. From kits for keen youngsters just starting — to components for the dedicated enthusiast intent on building his own computer, it can all be seen and bought on the spot in the Seymour Hall this November. Browse through the range of instrumentation, test gear, components and circuit boards. Kits for making everything from an electric grandfather clock to an electronic organ. Build your own microprocessor, construct your own television games and choose hi-fi audio modules for the ultimate in sound!

Watch the Demonstrations in adjoining halls — electronic projects brought to life by the experts — and a chance for you to try for yourself the latest ideas from manufacturers and journals.

Competitions — Win a microprocessor kit — a frequency counter — a 'starter' kit for the kids — and many other daily prizes throughout the show.

Open 10 a.m. — 7 p.m. daily.
Entrance £1.00 adults, 70p students.

Organised by Trident Conferences and Exhibitions Limited, Abbey Mead House, 23a Plymouth Road, Tavistock, Devon. PL19 8AU.
Tel: 0822 4671 Telex: 45412 TRITAV.

DORAM

SEE THE RANGE OF MULTIMETERS IN THE NEW DORAM HOBBIES CATALOGUE.

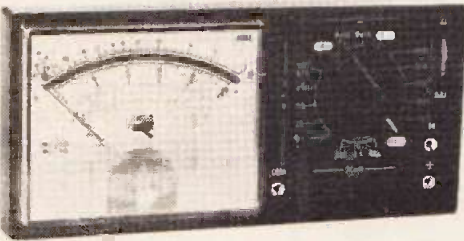

Doram Electronics Ltd
PO Box TR8, Leeds LS12 2UF

Please send my FREE Hobbies Catalogue (AVAILABLE LATE SEPT)

I enclose 25p contribution to p & p

Name _____

Address _____

DORAM Doram Electronics Ltd
PO Box TR8, Leeds LS12 2UF

Overseas customers (except for N. Ireland) - 60p including despatch by Air (or all-up post).

TRANSFORMERS

Panel Meters, Bridge Rectifiers, Power Supply Units
Multimeters - Semi Conductors - Timers - Safeloc

Miniature & Sub Miniature

Volts	Milli-amps	Ref. No.	Price	P&P
3.0-3	1A 1A	238	1.95	55
0.6-0.6		212	2.60	55
9.0-9	330 330	13	1.85	40
0.9-0.9	500 500	235	1.95	40
0.8-9, 0.8-9	1A 1A	208	3.50	55
0.15-0.15	200 200	236	1.95	40
0.20-0.20	300 300	214	2.35	70
20-12-0-12-20	700(DC)	221	3.10	70
0.15-20, 0.15-20	1A 1A	206	4.20	85
0.15-27, 0.15-27	500 500	203	3.65	70
0.15-27, 0.15-27	1A 1A	204	4.75	85

12 AND/OR 24 VOLT Pri 220-240 Volts

12V	24V	Ref.	Price	P&P
0.5	0.25	111	1.95	55
1.0	0.5	213	2.30	70
2	1	71	2.90	70
4	2	18	3.75	70
8	4	108	6.25	1.00
10	5	72	6.95	1.00
12	6	116	7.85	1.00
16	8	17	9.25	1.10
20	10	115	12.75	1.30
30	15	187	16.60	1.30
60	30	226	22.90	1.60

30 VOLT (Pri 220-240V) Sec 0-12-15-20-24-30V

Amps	Ref. No.	Price	P&P
0.5	112	2.45	70
1.0	79	3.05	70
2.0	3	4.80	85
3.0	20	5.80	1.00
4.0	21	6.85	1.00
5.0	51	7.75	1.00
6.0	117	9.50	1.00
8.00	88	11.35	1.30
10.0	89	12.00	1.30

CATALOGUE 30p

Please add VAT at 8%
Barclaycard and Access facilities available
Trade and Education Welcome

50 VOLT (Pri 220-240V) Sec 0-19-25-33-40-50V

Amps	Ref. No.	Price	P&P
0.5	102	3.20	70
1.0	103	4.20	85
2.0	104	6.10	1.00
3.0	105	7.85	1.00
4.0	106	9.80	1.10
6.0	107	14.95	1.30
8.0	108	15.75	1.50
10.0	119	20.50	2.00

60 VOLT (Pri 220-240V) Sec 0-24-30-40-48-60V

Amps	Ref. No.	Price	P&P
0.5	124	3.40	70
1.0	126	4.65	85
2.0	127	6.50	1.00
3.0	125	9.15	1.10
4.0	123	11.25	1.30
5.0	40	11.60	1.30
6.0	120	14.75	1.40

AUTO TRANSFORMERS

Input/Output Tapped 0-115-210-240V VA (Watts)	Ref. No.	Price	P&P
20	113	2.25	70
75	64	3.50	70
150	4	5.35	85

Input/Output Tapped 0-115-210-220-240V

VA (Watts)	Ref. No.	Price	P&P
300	66	7.15	1.00
500	67	10.75	1.30
1000	64	17.00	1.40

Also 1500/2000/2000/3000VA

MAINS ISOLATING (Centre Tapped & Screened)

Pri 120/240 Sec 120/240V VA (Watts)	Ref. No.	Price	P&P
60	149	5.75	85
100	150	6.40	1.00
200	151	10.00	1.10
250	152	11.95	1.30
350	153	14.45	1.40
1000	156	35.00	3.00

BAYDIS

54a Mortimer Street
Herne Bay, Kent
Herne Bay G45 88E

IT'S FREE!

Our monthly Advance Advertising Bargains List gives details of bargains arriving or just arrived - often bargains which sell out before our advertisement can appear. - It's an interesting list and it's free - just send S.A.E. Below are a few of the bargains still available from previous lists.

FM Tuner and decoder. 2 very well made units, nice clear dial, excellent reproduction. £11.20 the pair

12 Volt Heavy Duty Relay, plug in type has three pairs of 10amp changeover contacts. A transparent dust cover. price £1.08 suitable 11 pin base 45.

Light Dimmer. our timer module with 5MR mods makes an excellent light dimmer. Contains a 4amp 400V SCR so it should be suitable for loads approaching 1kW. Price of module and instructions £2.25.

Flashing Lights, chasing lights, random flashes, strobe effects etc. etc. can easily be achieved using our disco switches. These switches are ex-equipment but guaranteed perfect and supplied suitable for mains wiring. To get some ideal of the loading numbers each switch is 10amp.

For the right pipe or Catherine Wheel effect order the 12 switch model with light pipe data model. Interconnecting the switches to give the latest speed of switch model £5. 9 switch model £3.75. 12 switch model £5.20.

Wood Switches. standard 60 watt glass type. Normal open contacts glass lengths 2". diameter 3/4", 10 for £1. 100 for £8. 1000 for £70.

Flat Reed Switches. for stacking, greater quantity in confined space. Price 5p.

Chromatic Magnets. suitable for operating reed switches, central fixing hole, 10 for £1.

W Shaped Fluorescent Tubes for porch light, box signs or where you want light evenly spaced over a cashed area approx. 10" x 10". 30 watts, made by Philips price £2.24.

Continuum Speakers. 8cm 4.5 watts handling power. We have 5 or 6 different models in stock, cheapest being the Party tone at £3.95 each, again only really a bargain for collectors as postage is £1.50 per speaker.

Auto Transformers isolated secondary, for working American tools and equipment, completely included in sheet metal case made for computer so obviously first class 500 watts. With handle, offered at about half price only £15. These may be ordered but are fully guaranteed. Smaller 100 watt £9.50.

Star Starter Charger for New Verdes. We supply two 70amp rectifiers. 250V transformers and the start charge switch with instructions. price £9.75. This is probably one of the most useful pieces of equipment you can have in your garage. Sooner or later you or someone will need something or need you have a flat battery, this starter will get you away normally in less than 5 minutes.

Resistor Counter by Veeferool Company. 230/240 V mains operated. Intended for surface mounting has a fixing flange at the bottom. Price £2.16

3 Drive Reed Relay Specially designed for going under the bonnet of a car, made by one of our top manufacturers this has a removable semi-hard rubber cover. Contacts look massive for so in 10amp or 15amp. This could be the right one if you are thinking of making a new-car device. Price £1-15p.

High Speed Dissector. As many customers know, we have a very comprehensive stock of multimeters used in automatic telephone exchanges, light flashing devices etc., etc. Just arrived however is a high speed model made by famous Plessey, this is a 32 way with auto balance break wipers, overall size approx. 4" x 3" x 2 1/2". Price £3.50-20p.

Plastic Climber. for lifting, thrusting, pulling etc. has 2 1/2" travel, looks large enough to use indoors. Int. staircase ventilator etc. Price £7.00

Solder Gun SAG-6M The CTP this is 100 watt soldering gun a very well made tool with ceramic insulation, designed we believe to automatically operate typewriters and they can be used to operate other push type controlled machines. Reference No. is NCR Class No. 2. Reference 255/48/856. We believe these are 9 bit tape punches, powered from 1.5V 200mA, a very good condition with tape £16.00, carriage is £3.20.

Interconnect (Tape Control) American made tape punches really beautiful units full of economical parts, designed we believe to automatically operate typewriters and they can be used to operate other push type controlled machines. Reference No. is NCR Class No. 2. Reference 255/48/856. We believe these are 9 bit tape punches, powered from 1.5V 200mA, a very good condition with tape £16.00, carriage is £3.20.

Interconnect (Tape Control) American made tape punches really beautiful units full of economical parts, designed we believe to automatically operate typewriters and they can be used to operate other push type controlled machines. Reference No. is NCR Class No. 2. Reference 255/48/856. We believe these are 9 bit tape punches, powered from 1.5V 200mA, a very good condition with tape £16.00, carriage is £3.20.

Interconnect (Tape Control) American made tape punches really beautiful units full of economical parts, designed we believe to automatically operate typewriters and they can be used to operate other push type controlled machines. Reference No. is NCR Class No. 2. Reference 255/48/856. We believe these are 9 bit tape punches, powered from 1.5V 200mA, a very good condition with tape £16.00, carriage is £3.20.

Interconnect (Tape Control) American made tape punches really beautiful units full of economical parts, designed we believe to automatically operate typewriters and they can be used to operate other push type controlled machines. Reference No. is NCR Class No. 2. Reference 255/48/856. We believe these are 9 bit tape punches, powered from 1.5V 200mA, a very good condition with tape £16.00, carriage is £3.20.

Interconnect (Tape Control) American made tape punches really beautiful units full of economical parts, designed we believe to automatically operate typewriters and they can be used to operate other push type controlled machines. Reference No. is NCR Class No. 2. Reference 255/48/856. We believe these are 9 bit tape punches, powered from 1.5V 200mA, a very good condition with tape £16.00, carriage is £3.20.

Interconnect (Tape Control) American made tape punches really beautiful units full of economical parts, designed we believe to automatically operate typewriters and they can be used to operate other push type controlled machines. Reference No. is NCR Class No. 2. Reference 255/48/856. We believe these are 9 bit tape punches, powered from 1.5V 200mA, a very good condition with tape £16.00, carriage is £3.20.

Interconnect (Tape Control) American made tape punches really beautiful units full of economical parts, designed we believe to automatically operate typewriters and they can be used to operate other push type controlled machines. Reference No. is NCR Class No. 2. Reference 255/48/856. We believe these are 9 bit tape punches, powered from 1.5V 200mA, a very good condition with tape £16.00, carriage is £3.20.

Interconnect (Tape Control) American made tape punches really beautiful units full of economical parts, designed we believe to automatically operate typewriters and they can be used to operate other push type controlled machines. Reference No. is NCR Class No. 2. Reference 255/48/856. We believe these are 9 bit tape punches, powered from 1.5V 200mA, a very good condition with tape £16.00, carriage is £3.20.

Interconnect (Tape Control) American made tape punches really beautiful units full of economical parts, designed we believe to automatically operate typewriters and they can be used to operate other push type controlled machines. Reference No. is NCR Class No. 2. Reference 255/48/856. We believe these are 9 bit tape punches, powered from 1.5V 200mA, a very good condition with tape £16.00, carriage is £3.20.

Interconnect (Tape Control) American made tape punches really beautiful units full of economical parts, designed we believe to automatically operate typewriters and they can be used to operate other push type controlled machines. Reference No. is NCR Class No. 2. Reference 255/48/856. We believe these are 9 bit tape punches, powered from 1.5V 200mA, a very good condition with tape £16.00, carriage is £3.20.

Interconnect (Tape Control) American made tape punches really beautiful units full of economical parts, designed we believe to automatically operate typewriters and they can be used to operate other push type controlled machines. Reference No. is NCR Class No. 2. Reference 255/48/856. We believe these are 9 bit tape punches, powered from 1.5V 200mA, a very good condition with tape £16.00, carriage is £3.20.

Interconnect (Tape Control) American made tape punches really beautiful units full of economical parts, designed we believe to automatically operate typewriters and they can be used to operate other push type controlled machines. Reference No. is NCR Class No. 2. Reference 255/48/856. We believe these are 9 bit tape punches, powered from 1.5V 200mA, a very good condition with tape £16.00, carriage is £3.20.

Interconnect (Tape Control) American made tape punches really beautiful units full of economical parts, designed we believe to automatically operate typewriters and they can be used to operate other push type controlled machines. Reference No. is NCR Class No. 2. Reference 255/48/856. We believe these are 9 bit tape punches, powered from 1.5V 200mA, a very good condition with tape £16.00, carriage is £3.20.

Interconnect (Tape Control) American made tape punches really beautiful units full of economical parts, designed we believe to automatically operate typewriters and they can be used to operate other push type controlled machines. Reference No. is NCR Class No. 2. Reference 255/48/856. We believe these are 9 bit tape punches, powered from 1.5V 200mA, a very good condition with tape £16.00, carriage is £3.20.

Interconnect (Tape Control) American made tape punches really beautiful units full of economical parts, designed we believe to automatically operate typewriters and they can be used to operate other push type controlled machines. Reference No. is NCR Class No. 2. Reference 255/48/856. We believe these are 9 bit tape punches, powered from 1.5V 200mA, a very good condition with tape £16.00, carriage is £3.20.

Interconnect (Tape Control) American made tape punches really beautiful units full of economical parts, designed we believe to automatically operate typewriters and they can be used to operate other push type controlled machines. Reference No. is NCR Class No. 2. Reference 255/48/856. We believe these are 9 bit tape punches, powered from 1.5V 200mA, a very good condition with tape £16.00, carriage is £3.20.

Interconnect (Tape Control) American made tape punches really beautiful units full of economical parts, designed we believe to automatically operate typewriters and they can be used to operate other push type controlled machines. Reference No. is NCR Class No. 2. Reference 255/48/856. We believe these are 9 bit tape punches, powered from 1.5V 200mA, a very good condition with tape £16.00, carriage is £3.20.

Interconnect (Tape Control) American made tape punches really beautiful units full of economical parts, designed we believe to automatically operate typewriters and they can be used to operate other push type controlled machines. Reference No. is NCR Class No. 2. Reference 255/48/856. We believe these are 9 bit tape punches, powered from 1.5V 200mA, a very good condition with tape £16.00, carriage is £3.20.

Interconnect (Tape Control) American made tape punches really beautiful units full of economical parts, designed we believe to automatically operate typewriters and they can be used to operate other push type controlled machines. Reference No. is NCR Class No. 2. Reference 255/48/856. We believe these are 9 bit tape punches, powered from 1.5V 200mA, a very good condition with tape £16.00, carriage is £3.20.

Interconnect (Tape Control) American made tape punches really beautiful units full of economical parts, designed we believe to automatically operate typewriters and they can be used to operate other push type controlled machines. Reference No. is NCR Class No. 2. Reference 255/48/856. We believe these are 9 bit tape punches, powered from 1.5V 200mA, a very good condition with tape £16.00, carriage is £3.20.

Interconnect (Tape Control) American made tape punches really beautiful units full of economical parts, designed we believe to automatically operate typewriters and they can be used to operate other push type controlled machines. Reference No. is NCR Class No. 2. Reference 255/48/856. We believe these are 9 bit tape punches, powered from 1.5V 200mA, a very good condition with tape £16.00, carriage is £3.20.

Interconnect (Tape Control) American made tape punches really beautiful units full of economical parts, designed we believe to automatically operate typewriters and they can be used to operate other push type controlled machines. Reference No. is NCR Class No. 2. Reference 255/48/856. We believe these are 9 bit tape punches, powered from 1.5V 200mA, a very good condition with tape £16.00, carriage is £3.20.

Interconnect (Tape Control) American made tape punches really beautiful units full of economical parts, designed we believe to automatically operate typewriters and they can be used to operate other push type controlled machines. Reference No. is NCR Class No. 2. Reference 255/48/856. We believe these are 9 bit tape punches, powered from 1.5V 200mA, a very good condition with tape £16.00, carriage is £3.20.

Interconnect (Tape Control) American made tape punches really beautiful units full of economical parts, designed we believe to automatically operate typewriters and they can be used to operate other push type controlled machines. Reference No. is NCR Class No. 2. Reference 255/48/856. We believe these are 9 bit tape punches, powered from 1.5V 200mA, a very good condition with tape £16.00, carriage is £3.20.

Interconnect (Tape Control) American made tape punches really beautiful units full of economical parts, designed we believe to automatically operate typewriters and they can be used to operate other push type controlled machines. Reference No. is NCR Class No. 2. Reference 255/48/856. We believe these are 9 bit tape punches, powered from 1.5V 200mA, a very good condition with tape £16.00, carriage is £3.20.

MULLARD UNILEX



A mains operated 4+4 stereo system. Rated one of the finest performers in the stereo field they would make a wonderful gift to almost any one in easy to assemble modular form and complete with a pair of Plessey speakers this should cost at about £30 - but due to a special bulk buy and as an incentive for you to buy this month we offer the system complete at only £15 including VAT and postage.

High Voltage Mains transformer. Normal mains primary secondary by our measuring equipment is 8kV approx. at 5mA. We are offering these at a bargain price of £4.50.

MICRO PROCESSOR - VIATRON U.S.A. SYSTEM 21

Just arrived a limited quantity only of these superior V.D.U. M.P.U. Systems.

System 21 consists of a £250 video monitor 75 key fully coded keyboard with shift and repeat functions, dual digital record replay cassette decks and main M.P.U. housing. Memory P.S.U. refresh and control logic all housed in attractive desk standing console.

Features include:-

Full cursor control
hard wired programmes
automatic tape data block search, etc. etc.

Supplied complete with manual and secondhand untested bargain price of £185, personal collection only please.

WHAT COULD YOU BE DOING? in one year's time. If you understand computer and microprocessor technology? Think it over, then join the "Doing it digitally" course which is starting now. You will learn mainly by doing, not just reading. It's easy to understand that way.

Pay as you learn - Just £5 deposit and eleven monthly payments of £3. (or £35 cash now). £23 worth of components sent now, more will follow as course requires them.

REMEMBER THIS IS YOUR CHANCE?

Terms, Prices (Except Transformers) include Post & VAT. But orders under £6.00 please add 50p to offset packing. Bulk enquiries - Please phone for Generous Discounts 01-688 1833

J. BULL (ELECTRICAL) LTD

103 TAMWORTH RD.
CROYDON CR8 1SG

MAINS TRANSFORMERS

All these have 230/240V 50Hz Primary & isolated secondaries

VOLTAGE	CURRENT	REF.	PRICE
1V	2 amp	TM1	£1.84
2.4V	5 amp	TM2	£1.82
4V	7 amp	TM32	£2.70
6V	1/2 amp	TM3	.85
6.5V	3/4 amp	TM37	.85
6.5V	200mA	TM21	£1.62
6.5V 0-0-5v	100 mA	TM21	£1.62
6.5V 0-6.3v	750 mA	TM7	£2.16
6.3V 0-6.3v	100 mA	TM33	£1.62
6.3v	2 amp	TM4	£1.89
8.5v	1 amp	TM12	£1.62
8.5v + 8.5 sep winding	1 amp	TM12	£1.62
9v	1/2 amp	TM5	£1.62

ETI SPECIALS



£2.50 + 25p P&P

1 + 2—Top projects include Master mixer, 100 W guitar amp, low power laser, printmeter, transistor tester, mixer preamp, logic probe.



£1.00 + 25p P&P

Ni-Cad charger, loudhailer, scope calibrator, electronic ignition, car theft alarm, turnindicator canceller, brake

light warning, LM380 circuits, temperature alarm, aerial matcher, UHF TV preamp, metal locator, four-input mixer, IC power supply, rumble filter IC tester, ignition timing light, 50 W stereo amp, plus many more.

3—This issue was so popular that it is now sold out!
4—Includes Sweet sixteen stereo amp, waa-waa, audio level meter, expander/compressor, car theft alarm, headlight reminder, dual-tracking power supply, audio millivoltmeter, temperature meter, intruder alarm, touch switch, push-button dimmer, exposure meter, photo timer, electronic dice, high-power beacon, electronic one-armed bandit!
5—Twenty-two complete projects, including 5 W stereo amp, stage mixer, disco mixer, touch organ, audio limiter, infra-red intruder alarm, model train controller, reaction tester, headphone radio, STD timer, double dice, gen. purpose power supply, logic tester, power meter, digital voltmeter, universal timer, breakdown beacon, heart rate monitor, IB metal locator, temperature meter.
6—Just published, includes Graphic equaliser, 50-100 W amp, modules, active crossover, flash trigger, "star and dot" game, burglar alarm, pink noise generator, sweep oscillator, marker generator, audio-visual metronome, LED dice, skeet game, lie detector, disco light show....



75p + 25p P&P

Comprised entirely of new material, the edition covers such diverse subjects as Star Wars and hi-fi! The magazine contains projects for everyone — none of which have appeared in ETI — and a look at the future of MPUs, Audio, Calculators and Video. How can you not read it?

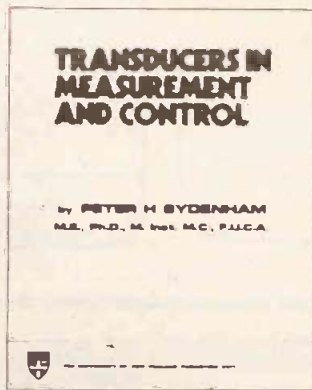

£3.00 + 25p P&P

This book is rather an unusual reprint from the pages of ETI. The series appeared a couple of years ago in the magazine, and was so highly thought of by the University of New England that they have re-published the series

splendidly for use as a standard textbook. Written by Peter Sydenham, M.E., Ph.D., M.Inst.M.C., F.I.I.C.A., this publication covers practically every type of transducer and deals with equipment and techniques not covered in any other book. Enquiries from educational authorities, universities and colleges for bulk supply of this publication are welcomed. These should be addressed to H. W. Moorshead, Editor.

HOW TO ORDER

Postage and packing also refers to overseas. Send remittance in sterling only.

ETI Specials
ETI Magazine
25-27 Oxford Street
London W1R 1RF

Please mark the back of your cheque or PO with your name and address.

Please supply me with the following ETI Specials:

.....

.....

.....

.....

.....

.....

Total cheque/PO enclosed = £ ..
Address:

M

.....

.....

.....

.....



£1.50

Each volume contains over 150 circuits mainly drawn from the best of our Tech-Tips. The circuits are indexed for rapid selection and an additional section is included which gives transistor specs, and plenty of other useful data. Sales of this publication have been phenomenal — hardly surprising when the circuits cost under 1p each! Each volume costs.

£1.50 + 25p P&P



£1.20 + 25p P&P

Our successful beginners series came to an end some time ago now and the whole series is available from us in reprint form. The three books between them contain all the information presented in the series (sometimes in more detail) and together form an excellent starting point for anyone interested in learning the art of electronics. Each volume costs

computing today

No 1

November
78

more on
TRITON

THE NEW MAGAZINE FOR SMALL SYSTEMS WITH BIG IDEAS

CUTS Card

Basically BASIC

NASCOM

Presented as a supplement to ETL.

Hop on a Nasbus to 32K of memory now

The Nascom - 1 is designed with expansion in mind. This is made possible by using the best products available. The Z80 microprocessor incorporated in the basic system is so powerful it can support 64K bytes of memory and 256 ports. To utilize this capability, we have designed the buffered 77 - way Nasbus.

With this arrangement, the way is clear for considerable expansion, starting with our new memory expansion board. It has 16 memory sockets and two EPROM sockets. Therefore, you can fill it with 4K dynamic RAM up to a maximum 8K or with 16K dynamic RAM up to a maximum of 32K. A 2K Tiny BASIC in EPROM has been developed for the board.

To go with the board, we have produced a very flexible I.O board with three PIOs each giving two, 8bit ports, plus a UART for serial interface.

As you start building up your Nascom system you will need a convenient means of storing boards. Our new, custom-designed, Vero frame

will allow for a Nascom - 1 to link through a buffer board to a 77-way Motherboard. There is then the option of eight or more expansion boards. To power this capability there is a new 8.5 amp power supply especially designed for the frame.

No other system offers so much at such a low cost. And it all starts with the basic Nascom - 1 kit which for just £197.50 offers an intelligently usable system with video and cassette interface, a full alpha-numeric keyboard and a mighty CPU chip. So if you want the best - make it a Nascom system.

**Nascom-1 Kit still only
£197.50 +VAT**



UK National Distributors

Camera Centre,
Barrow-in-Furness, Cumbria

Crystal Electronics,
Torquay, Devon

Electrovalue,
Egham & Manchester

Eley Electronics,
Glenfield, Leicester

Henry's Radio,
London W2

Lock Distribution,
Oldham, Lancs

Lynx Electronics,
Chesham, Bucks

Microdigital,
Liverpool L2

Teleplay,
New Barnet, Herts

Stop press...

Microcomputer Seminar

Nascom Microcomputer's highly successful seminar is coming to Bristol. The programme will be similar to London and Manchester, both of which were sold out. The day includes five lectures, demonstrations and an open forum. Venue is the Dragonara Hotel, Bristol, Saturday, October 14th, 09.50 to 17.30.

Admission: £4.50 (inc. VAT). Lunch will be available at £4.00 (inc. VAT) per head if there is sufficient demand.

Please send me

..... tickets to your seminar at £4.50 each and further details on Nascom-1 expansion products/Nascom-1 Kit/Int. Nascom Microcomputer Club.*

*delete as applicable



Nascom Microcomputers

92 Broad Street, Chesham, Bucks.
Tel: (02405) 75151

Name _____

Address _____

Tel. No _____

Cut out coupon and post to Nascom Microcomputers. Cheques and PO's should be made payable to Nascom Microcomputers.

CT117

computing today

NO 1 november 1978

NASCOM 1 REVIEW	5	Nice one NASCOM
BASIC EXPLAINED	9	Say no more
CUTS CARD	15	CUTS above the rest
TRITON IMPRESSIONS	19	Colling all TRITON users
EAST COAST REPORT	21	Important show for US
TRITON BASIC	23	Try it on Triton
MICROFILE	30	Gary Evans in training

EDITORIAL ADVERTISING PRODUCTION

Halvon W. Moorshead
 Ron Harris B.Sc
 Gary Evans
 Jim Perry
 Phil Cohen B.Sc, William King
 John Koblanski
 Steve Ramsahadeo
 Paul Edwards
 Margaret Hewitt
 Andrew Scott
 Kim Hamlin, Bren Goodwin
 Tim Salmon, Val Tregidgo
 Mark Strathern (Manager), Tom Moloney

INTRODUCTION

The first issue of any magazine is an exciting time — certainly for the people working on the project and, hopefully, for the readers. Computing Today, although presented free with ETI, is just such a new magazine, which will have a style and identity of its own.

Computing Today will cover the fields of computing, from the home, education, and small business viewpoints. Computing to us will mean everything from the complete small business system, floppies and all, to a single bit micro in a control application.

The growth of small systems over the past few years has been astounding — the reasons for this growth are many and varied — we won't go into them here — and it is our hope that the next few years will see this expansion maintained.

One of the reasons for launching Computing Today was the fact that it was no longer possible to devote enough space within ETI to cover this important area of small systems without sacrificing other features of ETI that are equally important to many of our readers. ETI plus CT will allow us to keep everybody happy.

Although this first issue of CT is only 32 pages, if the growth we mentioned is maintained, rest assured that CT will grow to keep pace.

This first issue of CT is published to coincide with the launch of the TRITON, an exciting new system for the hobbyist/education areas. CT has similar, equally exciting projects in the pipeline and if you don't want to miss out on important news and developments in Computing be sure to read us every month.

Airamco Ltd. MICRO COMPUTER PRODUCTS

Distributors for JADE COMPUTER PRODUCTS
 All products brand new with full industrial specification

S100 COMPUTER CARDS KIT	ASSEMBLED	BARE BOARD
Mother Board	£71.00	£26.25
Desk Top Rack, 12 slot mother board + 15A @BV, 2A @ ± 16V	£199.00	
Jade 8080A CPU BOARD	£75.00	£122.50
Jade Z80 CPU BOARD 2MHz	£99.95	£138.75
Jade Z80 CPU BOARD 4MHz	£112.50	£149.95
Jade Serial / Parallel I/O BOARD	£93.70	£134.29
Jade 2708 / 2716 EPROM BOARD	£44.95	£82.46
(16x2708 or 2716) WITH 8 2708s	£97.46	£134.96
Jade REAL TIME CLOCK BOARD	£93.71	£134.96
Problem Solvers 16K STATIC RAM 450nS	—	£270.00
16K STATIC RAM 250nS	—	£296.00
Jade 8K static RAM BOARD 450nS	£94.50	£112.50
Jade 8K static RAM BOARD 350nS	£104.95	£119.96
Jade 8K static RAM BOARD 250nS	£127.50	£142.50
S.D. Sales "EXPANDORAM" Dynamic Memory 375nS access time 8K	£113.25	—
Memory 375nS access time 16K	£189.00	£229.00
Memory 375nS access time 32K	£297.00	£337.00
Memory 375nS access time 64K	£513.00	£553.00
VERSAFLOPPY DISK CONTROLLER (up to 4 drives 5 1/4" or 8")	£11.75	—
SHUGART 8" Drive	—	£385.00
PERTEC 5 1/4" Drive	—	£225.00

Components	Price	Price	
2708 1024x8 EPROM	£6.99	21L02-1 450nS	£1.20
2716 2048x8 EPROM (intel)	£29.90	8 for	£7.92
2516 2048 x 8 EPROM	£29.90	21L02 250nS	£1.40
(equivalent of above) T.I.		8 for	£9.60
1702 256x8 EPROM	£4.85	2112-1 256x4 (450)	£2.25
2104 4096x1 DRAM	£3.50	4044 4Kx1 (450)	£7.45
8 for	£26.00	4045 1Kx4 (450)	£8.25
2107B-4 4096x1 DRAM	£3.50		
8 for	£26.00	Used North Star Mini disk system + controller + some software	£399.00
Note New Low Prices 16K Memory		8212	£2.49
4115 5kM DRAM	£9.99	8216	£2.75
4116 16kx1 DRAM	£14.99	8224.4	£7.46
8 for	£108.00	8226	£2.95
6821P PIA	£5.90	3881	£9.50
AY 51013 UART	£4.50	3882	£9.50
AY 51014 UART(5V)	£6.50	S100 Skts	£3.30
AY 53600 ENCODER	£9.99	Textool 24 pin Zero force Skt	£5.60
8080A CPU	£8.99	4115 8kx1 DRAM	£9.99
		81LS95	£1.25
		81LS97	£1.25

All Prices EXCLUDE VAT @ 8%

Trade discounts on Quantity
 Please add £1.00 P&P for S100 items then add VAT @ 8%

24-hr. Ansaphone order service with ACCESS or BARCLAY-CARD

MAIL ORDER ONLY



For components please add 40p P&P, then add VAT @ 8%.

AIRAMCO LTD.
 30 WITCHES LINN
 ARDROSSAN
 AYRSHIRE
 KA22 8BR
 TEL 0294 65530

Semiconductor prices are always changing and the trend is generally downwards. So ring for latest up-to-date details.

TANGERINE

COMPUTER SYSTEMS LIMITED



The new low cost VDU - Tangerine 1648
(See page 16, ETI, Oct '78 for feature details)

ORDERING INFORMATION

The normal **KIT price is £139.86**, which includes postage, packing and insurance and VAT @ 8%. HOWEVER, as an introductory gesture we are **discounting this price by £10**, for all orders received postmarked **BEFORE 12th December, 1978**.

If you require further information, send an A4 sized self-addressed envelope. If you wish to purchase a kit please send a cheque or money order made payable to:

TANGERINE COMPUTER SYSTEMS LIMITED

RIVERMILL LODGE, LONDON ROAD, ST. IVES,
CAMBS. PE17 4BR
Tel. St. Ives (0480) 65666

IN SCOTLAND

IN SCOTLAND

NASCOM 1

Z80 Microcomputer kit

Undoubtedly the finest value for money kit available anywhere. Fully socketed.

INTERFACE FOR:

TV (UHF)

TV Monitor

Cassette

Teletype

32k Ram expansion board

May be seen working
9 a.m. - 5 p.m. Mon.-Fri.

Callers welcome

Price **£197.50** + VAT (8%)

Callers welcome



STRATHAND
44 ST. ANDREW'S SQ.
GLASGOW G1 5PL
041-552 6731

Callers welcome



Tel. order welcome with Access and Barclaycard

B - BUG SUPER SMART NEW MONITOR FOR NASCOM OWNERS

FEATURES INCLUDE:—FULLY COMPATIBLE with existing hardware/software; **NEW TAPE I/O 4 TIMES FASTER** with extensive error checking (see cassettes below); **INTELLIGENT COPY** command for program relocation; **ARITHMETIC** for address and offset calculation; **HEX KEYBOARD** function — throw away your **ASCII** tables!; **SUPER-SHIFT** allows all displayable characters to be entered from the keyboard; **FLAG DISPLAY** shows the flags set — C, Z etc. when using the **EXTENDED REGISTER DISPLAY** which shows the IX, IY etc. registers as well; **SUBROUTINES** include:—**PSEUDO RANDOM NUMBER GENERATOR**; **ASCII to PACKED BCD** and vice-versa; **VARIABLE INTERRUPTABLE DELAY**; **CHARACTER STRING OUTPUT**; **TABLE SEARCH**; **STRING OUTPUT**; **CURSOR MOVEMENT**; **AUTO-RUN** facility allows a high-speed tape to be loaded and program executed with no operator intervention.

B.BUG is supplied in 2 x 2708 **EPROMS** which plug into your existing sockets. **NO MODIFICATIONS NEEDED**. Demand will be high and orders will be handled in strict rotation. Delivery currently ex-stock so **ORDER NOW AND BE A 'B.B.'!**

B - BUG in 2x2708's only £23.40 including documentation.

C10 DATA CASSETTES . . . 35 pence each (Nascom, Pet, TRS80, Apple, etc.).

Please add 30p p&p for orders under £10. VAT inclusive. E&O.E. Dealer enquiries welcome.

VIEWFAX LTD.
KING EDWARD BUILDING, CORPORATION STREET,
BIRMINGHAM B4 6SE.

We take a look at one of the most advanced CPUs evaluation kits

The Nascom 1 Reviewed

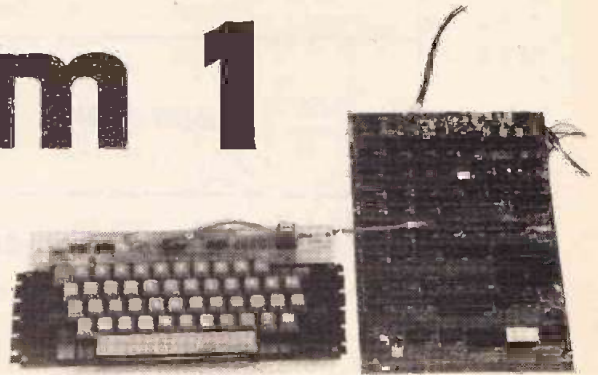

THE NASCOM 1 Microcomputer kit was launched by Lynx Electronics at the Wembley Conference in November 1977. At that time, a sales figure of 500 kits was anticipated but it has been so popular that orders in excess of 10 000 kits have now been received. A look at the main features of Nascom 1 will explain this success.

For £197.50, you get:
A Z-80 CPU,
an uncommitted PIO,
2K of static RAM,
a powerful 1K monitor (in a 2708 EPROM),
a TV modulator,
a full keyboard (assembled),
cassette or RS 232 interface (but not both at the same time),
an IM6402 UART,
a double-sided PCB with plated-through holes,
all other active and passive components, wire,
solder and complete documentation.

The system is easily expandable through a 43-way edge connector but there is no on-board buffering (due to cost) although Nascom's plans for future expansion include a buffer board. In order to have a working microcomputer, only a power supply and a domestic TV need be supplied, plus an ordinary portable cassette machine for program storage.

Construction

Constructing the kit is an easy task for the experienced constructor and even the first-timer should have no difficulty, providing the detailed and comprehensive instructions are followed carefully. It is, if anything, a little tedious — there are over 50 ICs, sockets are provided for all of them.

The PCB is worth special mention for its superb quality — a really professional job. All component and wiring positions are clearly marked on the board in a totally unambiguous fashion and since the instructions include a detailed section on component identification, there should be no location problems. The PCB has wire links to be made, each selecting a possible user option. Two deal with I/O port and memory selection, three with the UART and one with the on-board crystal clock. The instructions show standard connections for these links and explain the variations. They could also be replaced by miniature toggle switches to allow experimentation.

The keyboard is supplied pre-assembled and needs only the addition of the RESET switch to complete it. Again due to cost considerations, it is not ASCII coded, but is scanned by hardware under software control. Early keyboards had no engraving on the key tops for shifted characters but this has been corrected in a new version, which also has a more positive key action. However, both suffer from the amazing lack of a left-hand shift key!

Another minor criticism is the method of connection between the PCB and the keyboard. A multicore cable with a 16 pin DIL header plug is used at each end, which means that any strain on the cable is taken by the soldered joints. A proper ribbon cable with crimped connections to header plugs would be a much more satisfactory solution.

Power supply

The power supply requirements are:

- +12V @ 150mA,
- +5V @ 2A,
- 5V @ 90mA
- and -12V @ 12mA (for RS232 only).

Lynx supply a PSU kit as an extra but it does rather let down an otherwise excellent product. The kindest thing I could say about the design is that it is unusual. It allows for further PSU kits to be 'paralleled off' for expansion. Early PCBs also has the + and - rail markings reversed — one of the IC regulators' connections are incorrect, although the outline is right. There is no provision for diodes to protect against

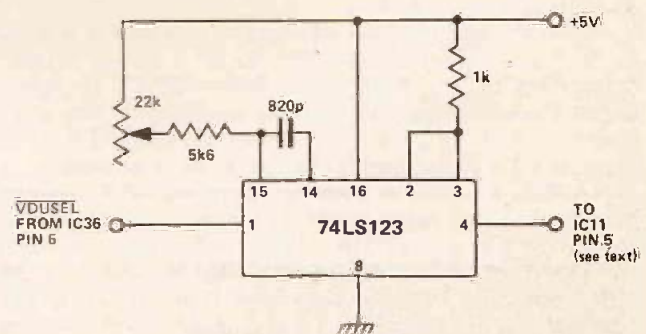

Fig. 1. Circuit to overcome 'snow' on multiple VDU RAM access.

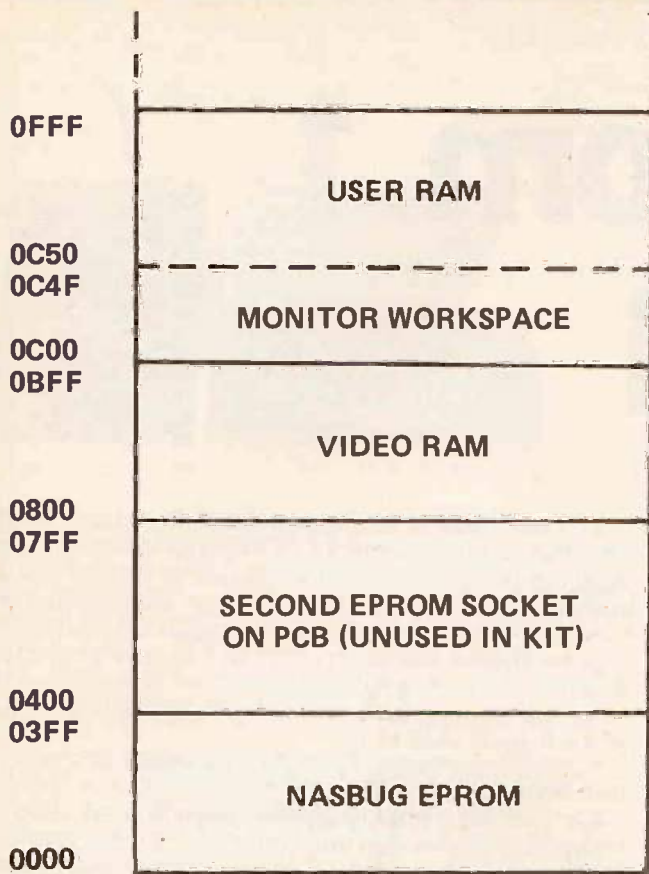

Fig. 2. System memory

voltage crossover (although diodes are supplied in the kit).

Now for the good news — the PSU is being completely re-designed and the parallel expansion approach dropped. Instead there will be an 8 amp kit for larger systems.

Memory and VDU

Before moving on to the operation of the kit, there are a couple of other hardware points to be mentioned. Firstly, the arrangement for resetting the CPU (by means of the RESET switch) would have to be altered for use with dynamic RAM expansion. CPU operation is suspended for as long as the RESET button is held down, so dynamic RAMs (assuming they are refreshed by the Z-80) would soon forget what they were doing. The buffer board will contain circuitry to correct this.

Secondly, the modulator seems to produce a very noisy signal. Picture quality is, to a large extent, dependant on the ability of a domestic TV to reject noise. Fortunately, commercial modulators are very cheap to buy and easy to fit to the NASCOM 1, as there is a 1V video signal output from the board.

NASCOM 1 uses a memory-mapped VDU, which means that the video RAM is shared with the CPU, the latter having priority. The instructions say that the video is blanked during VDU RAM access by the CPU but this is only partially true. In fact, the blanking signal (VDUSEL) is not long enough, so that a noise signal which shows as 'snow', especially on multiple VDU RAM access, appears on the screen.

This can be simply corrected by using the circuit in Fig. 1 Pin 5 of IC 11 should be bent out from the socket and the connection made with an insulated 'sodercon' socket. Increase the potentiometer value until the snow just disappears.

Display Format

The format of the display is 48 characters wide by 16 lines deep, which produces a very readable picture on a domestic TV. The remaining 256 bytes ($1024 - (48 \times 16) = 256$) of the 1K video RAM block are in the margin of the display, since the video RAM address counter is not disabled during the undisplayed portions of the video signal. In addition, the bottom 15 lines of the display (plus margins) are scrolled by the monitor, making the unused RAM locations useless.

The fact that only 15 lines are scrolled leaves the top line for header text or data. This is a very useful feature, since almost all programs can make use of a fixed display line. Figure 4 gives details of the VDU addressing and scrolling.

Operating System

The operating system is held in a 2708 (1K x 8) EPROM, which goes by the name of NASBUG. Since July, kits have been supplied containing NASBUG MK2 as the original version contained an error in the serial input routine and a couple of errors in the keyboard look-up table. However, these facts should not detract from the excellent software which is crammed into the 1K of NASBUG.

To call a command, only a single letter need be entered, followed by a number of arguments in HEX. Leading zeroes may always be omitted on input. The commands are as follows:

modify: M aaaa

The monitor responds by printing address aaaa followed by the contents of that memory location, followed by a prompt and the cursor. If only examination of the memory location is required, pressing NEWLINE will step through the memory sequentially, printing information in the same format. The command is aborted by fullstop newline. Memory may be modified by entering new data after the prompt.

tabulate: T aaaabbbb

Prints on the screen the contents of memory between addresses aaaa and bbbb.

copy: C aaaa bbbb cccc

Copies a block of memory, length cccc, from address aaaa to bbbb. Care must be taken that either bbbb is greater than aaaa plus cccc or that bbbb is less than aaaa, otherwise the data block will be corrupted.

execute: E aaaa

Executes a program starting at address aaaa. There are two occasions when no argument is required. Firstly, if a program is aborted by the RESET button, E NEWLINE will cause execution to start at the same place as the previous E command. Secondly, at a breakpoint, E with no argument will cause execution to resume from the breakpoint.

break: B aaaa

Will insert a special code at address aaaa in a user program. When this code is encountered during execution it will cause the program to stop, display

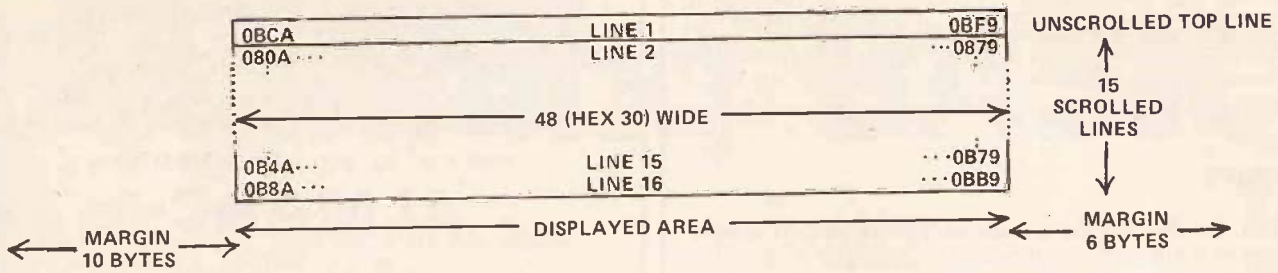

Fig. 4. VDU diagram

the registers and transfer control to the monitor. This means that any of the monitor commands may then be used. The BREAK command together with the STEP command provide very powerful debugging tools.

step: S aaaa

Will cause single step execution from address aaaa, with the registers displayed as in break at each step. Once single stepping is started, only NEWLINE need be pressed for the next stop and as with the execute command, the address will be assumed at a breakpoint.

dump: D aaaa bbbb

Dumps the contents of memory locations aaaa to bbbb to the serial output. Data is sent in blocks of 8 bytes, each with an address and checksum.

load: L

The opposite of dump. Loads data from the serial input (usually from cassette). The input format is the same as the dump output format (which is useful!).

Reflective Addressing

The monitor is made even more powerful by the use of 'reflective addressing' in the RAM. Some of the major routine addresses and data are found by the monitor by looking in certain RAM locations. The locations are set up at RESET but they can be changed manually (or during the course of a program).

The following data are found reflectively:

- NMI routine address (used in single step and breakpoint exit),
- command table address,
- CRT address which controls cursor and scrolling,
- keyboard scanning routine address,
- address of the keyboard lookup table and its length
- and the stack pointer address for user programs (i.e. end of RAM).

The use of reflection and a scanning keyboard gives NASCOM.1 the advantage that the meaning of the

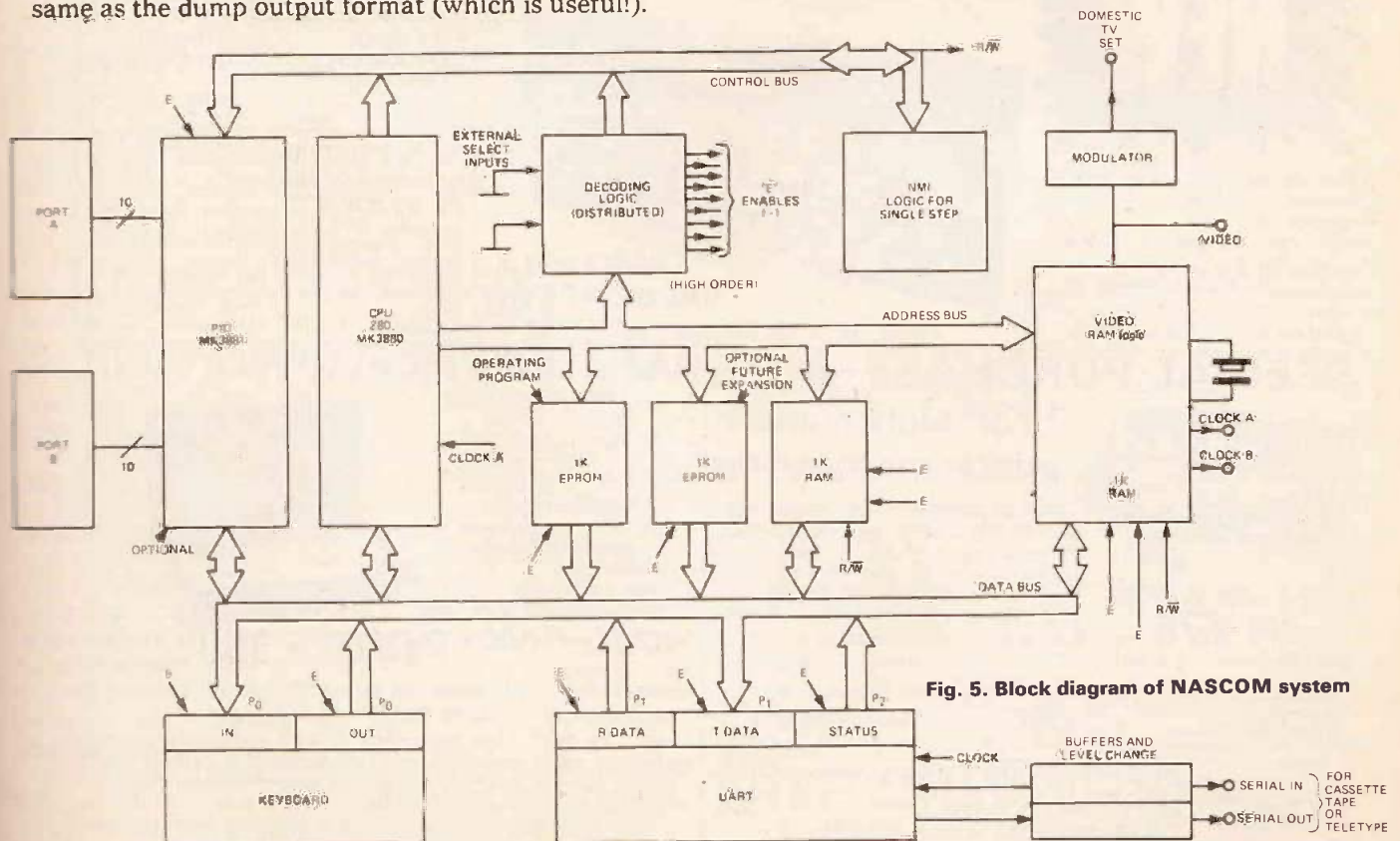

Fig. 5. Block diagram of NASCOM system

Nascom

keys may be changed with ease and various combinations of simultaneous key pressing can easily be detected and acted upon. An example of the use of this feature is a program called SUPERSHIFT, by Richard Beal. The @ key is utilised as a sort of control key, enabling the complete character set of the MCM 6576 character generator to be used via the keyboard.

Summary

Overall, the NASCOM 1 is an excellent unit. It is easy to level criticism at any product, especially one which has been designed down to a price, rather than up to a specification, but I think that the compromise has been very successful in this case. There have been delays in the delivery, mainly caused by underestimation of demand, which in turn has caused delays in the development and despatch of the advertised add-on goodies (up to and including mini-floppy). Hurry up, Lynx.

To finish on a personal note, I've been using my NASCOM 1 for about 5 months (it worked first time) and I am very happy indeed with it. I can hardly wait for 16K and an assembler (MENTAL NOTE: Must send Christmas card to bank manager), although I am continually surprised at what can be squeezed into the 944 bytes available. The monitor is easy to use and fairly comprehensive, bearing in mind that it is only 1K. Debugging is a doddle with breakpoint and single step. NASCOM 1 is a real microcomputer at a relatively low cost and should be easily expandable to a really powerful system.

CTI

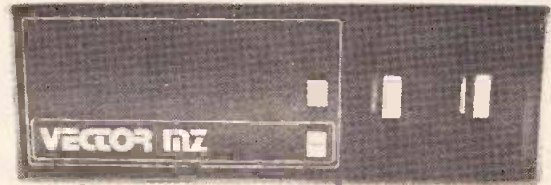

THE TOTAL SOLUTION FROM

ALMARC

OF COURSE!

Now Almarc & Vector Graphic offer the complete solution to your computing needs for £2300.00*. The Vector MZ needs only the addition of a V.D.U. and it's ready to go. Completely assembled and fully tested, the Vector MZ offers the following features as standard: —

- S-100 bus
- 4 MHz Z80A processor
- 158 instructions
- Two quad density Micropolis floppies — over 630k bytes on line
- Serial port
- Two parallel ports
- 32K static ram
- 12K prom/ram board with extended monitor
- Extended disc Basic

Simply connect your peripherals (Elbit V.D.Us & Centronics printers are available from Almarc) and you're up and running and, because the MZ uses the S-100 bus, you can plug in a massive range of add-on units.

Ring or write for a demonstration to —

ALMARC DATA SYSTEMS LTD.

29 Chesterfield Drive
Burton Joyce, Nottingham
Tel: 0602 248565

*Discount terms available



56-STATION ASCII KEYBOARD NOW IN STOCK — ASCII KEYBOARD MODEL KB756

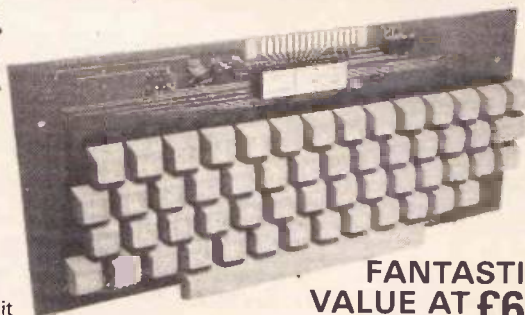

Full 128 character set with ROM encoder (Upper and lower case + control shift)
Fully TTL — compatible — power requirements +5v-12v.
Supplied with full technical data, code chart, pin connections, circuit diagram and application notes.

FANTASTIC
VALUE AT £60

+ £1.50 p&p + 8% VAT (mail order total £66.42)

SELF-SCAN ALPHANUMERIC PANEL DISPLAY

16/18 position display with 64 character repertoire, 5 x 7 dot matrix. Input 6-bit BCD code, power requirements +5v, -12v. Character size 0.40" x 0.28". Overall dimensions 8 1/4" x 2 1/4" x 1 1/4". Supplied with full technical data. Price £55.00 + 75p P&P + 8% VAT (Mail order total £60.21).

BALL MIRATEL VIDEO MONITOR

9" diagonal P4 phosphor tube. Bandwidth 12 MHz (-3dB). Input voltage 220V 50/60 Hz 24W. Output voltage +15V DC (short circuit protected) +12kV DC, 12.6V rms. Supplied complete with high & low voltage power supplies, amplifier, and attractive moulded plastic housing including space for keyboard. Price £95.00 + carriage + VAT.

SPECIAL PURCHASE — MITE



123P Alphanumeric printer mechanisms

Solenoid-operated page printer using standard reversible typewriter ribbon. Prints standard 64-ASCII character set on 8 1/2" paper (80 characters per line, 6 lines to the inch). Maximum speed 11 cps. Power requirements 115VDC. Compact, light-weight unit 9 1/4 lbs., 12" x 9" x 2 3/4". Supplied complete with full technical manual.

BRAND NEW SURPLUS
ONLY £75
+ £3.50 P & P + 8% VAT
(Mail order total £84.78)

We also specialise in: DEC minis — PDP8 and PDP11 processors, add-on memory, peripherals and spares. Hard copy terminals — ASR 33 and KSR 33 Teletypes, Data Dynamics 390, Texas Silent 700. Send for complete lists.

ELECTRONIC BROKERS LTD.
49-53 Pancras Road, London NW1 2QB.
Tel: 01-837 7781. Telex: 298694.

HAZELTINE VISUAL DISPLAY UNIT

- * Teletype Compatible
- * 12" Diagonal Screen
- * TTY Format Keyboard
- * 12 lines of 80 characters
- * 64 ASCII Character Set
- * 5 x 7 Dot Matrix
- * Switch-selectable Transmission Speeds up to 9600 baud
- * Switch-selectable Parity
- * Standard CCITT V.24 Interface



MODEL H-1000 PRICE £350 + carriage and VAT

Also available: —

Model H-1200: Specification as for H-1000 except 24 lines of 80 characters displayed. Price £425.00 + carriage + VAT.

Model H-2000: Buffered/Editing model with direct cursor addressing, dual intensity video, and detachable keyboard with separate numeric and edit clusters. 27 lines of 74 characters. Price £495.00 + carriage + VAT.

A copy of trading conditions supplied on request.

This month we feature the first part of a software teaching series

Beginning BASIC

PART 1 Algorithms and flow charts

IT IS, UNFORTUNATELY, VERY EASY when watching a computer in action to subconsciously endow the machine with intelligence — under no circumstances is this the case.

Regardless of whether you are programming in the simplest of machine codes or the most sophisticated of high level languages, there is no way that the computer can do anything other than what it has been programmed to do, and the signs of intelligence that we seem to detect are present only because of the skill of the programmer. In fact, programming today is becoming quite a major business area, simply because of the amount of skill involved. As with every other trade, however, there are various tools which are at the disposal of the programmer to help in his work — one of the most important of these being the flow chart.

It does not matter what language we program in, be it machine code or BASIC, the technique of drawing and using flow charts is always the same.

We start with a problem, find an algorithm (finding an algorithm for a problem means finding a method of giving a complete and correct solution to the problem in a finite number of steps) to solve the problem, draw the flow chart and then write the program from the flow chart. In order that one programmer can understand another's work, certain conventions are adopted when drawing flow charts (see Fig 1).

As a first example of algorithm and flow chart drawing, we will take the case of a young person applying for membership of a Social Club, wishing to discover what fees are payable as an annual subscription.

Consider the following —

"The annual subscription for a man is £10, unless he is under the age of 25, when the subscription shall be halved. The annual subscription for a woman shall be £8, unless she is under 25, when the subscription shall be halved. Married women applying for membership shall be charged half the amount payable by a single woman over 25."

In this instance, it is unnecessary to find an algorithm to solve the problem as we are only going to use the flow chart as a means of simplifying the wealth of information given above (see Fig 2).

So, for example, if you are a married female, it takes only a moment's glance at Fig 2 to answer the questions "Are you a man?" (no) and "are you married?" (yes) to arrive at the knowledge that your annual subscription shall be £4.

You can see from this example how the flow chart helps to clarify and simplify an otherwise apparently complicated problem.

We will now go on to consider the generation of an algorithm, and to see how a flow chart can be drawn once an algorithm has been obtained. As an example,

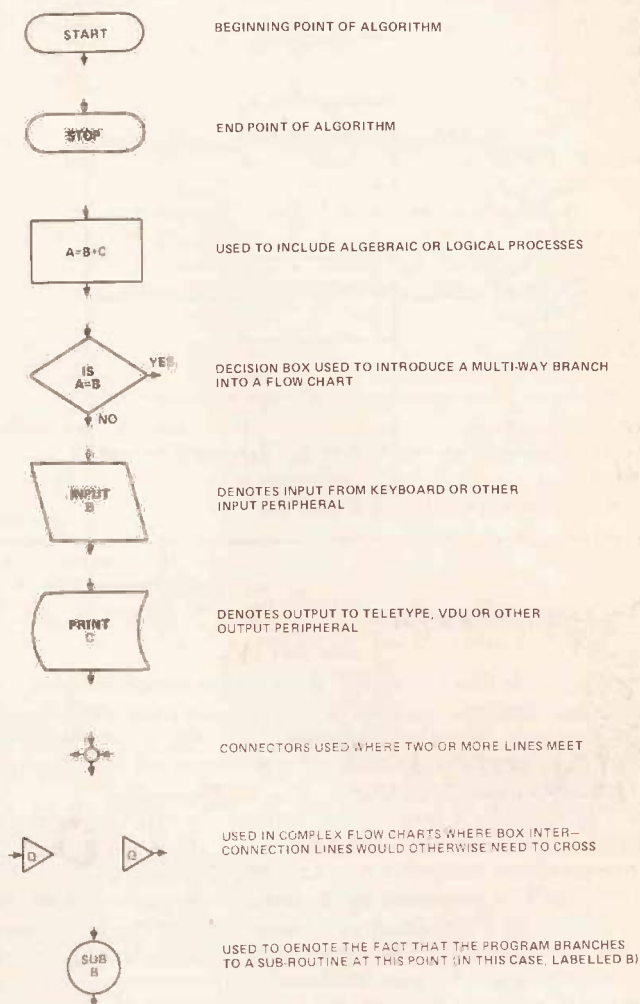

Fig. 1. Flowcharting symbols

we will look at how it might be possible to get a computer to generate a representation of, and randomly shuffle, a pack of cards.

The first thing we need to do is to decide what would be an acceptable representation of the pack. We could reasonably consider the problem solved if the computer could be made to generate a list of the numbers 1 to 52 in a random order, so that each number from 1 to 52 would represent a different card.

The first method that springs to mind is to get the computer to open a set of 52 storage locations. The first random number between 1 and 52 can then be generated and placed in storage location number 1 (the method used to generate the random numbers is

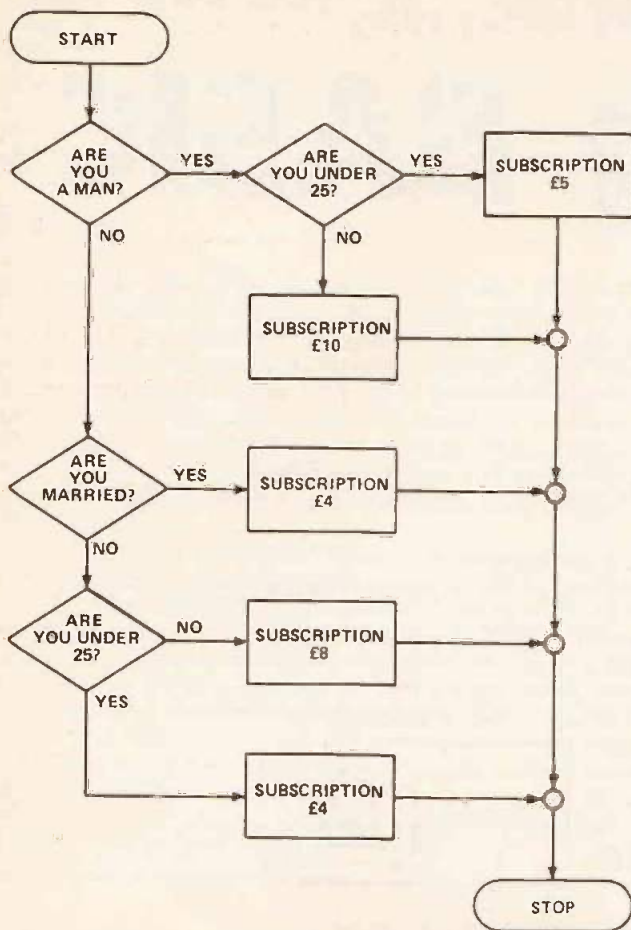

Fig. 2. Fee fie foe or fum?

unimportant as far as the flow chart is concerned). A second random number is then generated and placed in storage location number 2, a third number in storage location 3, and so on until all 52 storage locations have been filled.

Fig 3 shows a flow chart to describe this algorithm. That appeared quite simple, didn't it? But if we give the problem some further consideration, you will see it is possible, since the numbers we are generating are random, to have generated two numbers which are the same. Indeed, this is most likely. This would mean that we would have at least two cards the same within one pack, and so our algorithm must be considered incomplete (though on the right track). To make the algorithm work correctly, we will have to include some form of check to ensure that when a number is generated which has already been used, it is not included in the list (see Fig 4 for a flow chart which takes this point into account). If you look through Fig 4, you will see that a number is generated and then a check is made through all the storage locations that have already been filled to see if the number we have just generated has occurred before. If it has, then the number is ignored and a new random number is generated and checked; if it has not, then it is inserted into the next empty storage location. We then jump back and generate another random number and the process continues until all 52 storage locations have been filled.

This algorithm and subsequent flow chart would appear to be quite sufficient to solve the problem. But

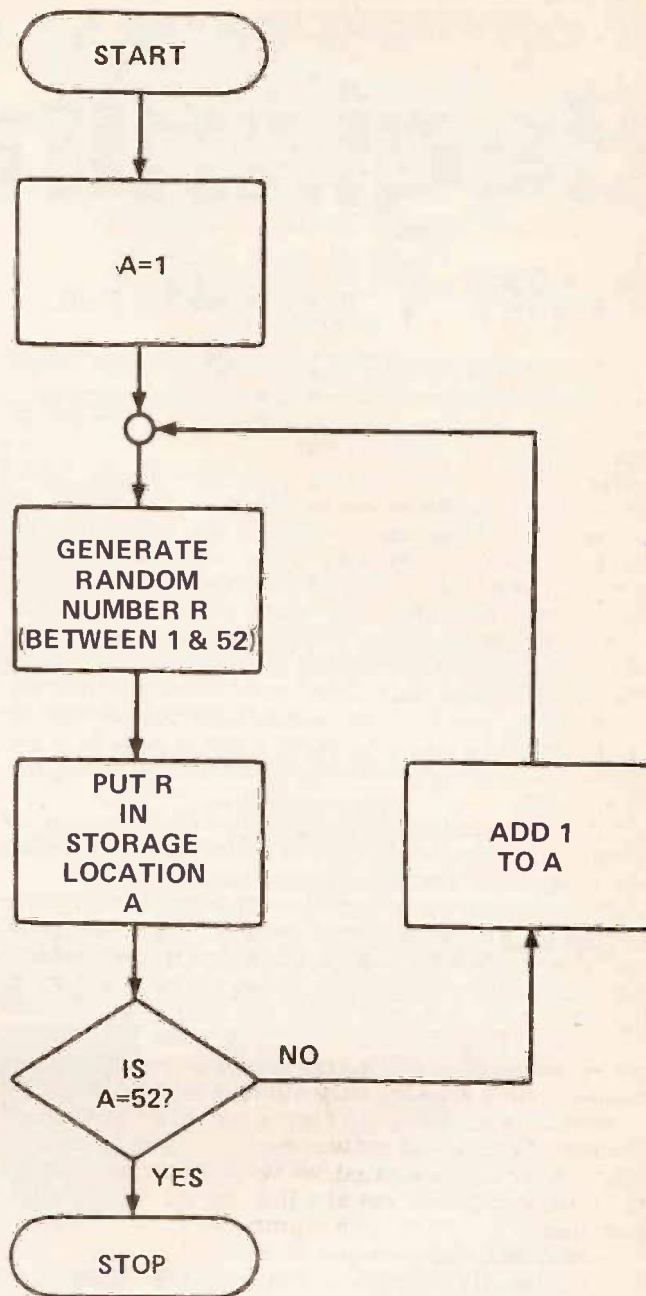

Fig. 3. Take a card, any card . . .

let us now consider this flow chart converted into a program and being run on a computer. Remember, every operation the computer executes takes some finite time to perform, albeit small, so that the more operations that need to be performed, the longer the program will take to run. This may appear to have been an obvious statement, but let us take a look now at our algorithm, bearing this point in mind. When we start off, with all storage locations empty, the first number we generate can be guaranteed not to have occurred before (though looking at the flow chart you will see that the computer does not know this) and can therefore be inserted straight into the first storage location. As the program proceeds, however, and more storage locations filled, it becomes more and more likely that the generated random number will, after some considerable checking, have to be abandoned and re-generated, until, when there are

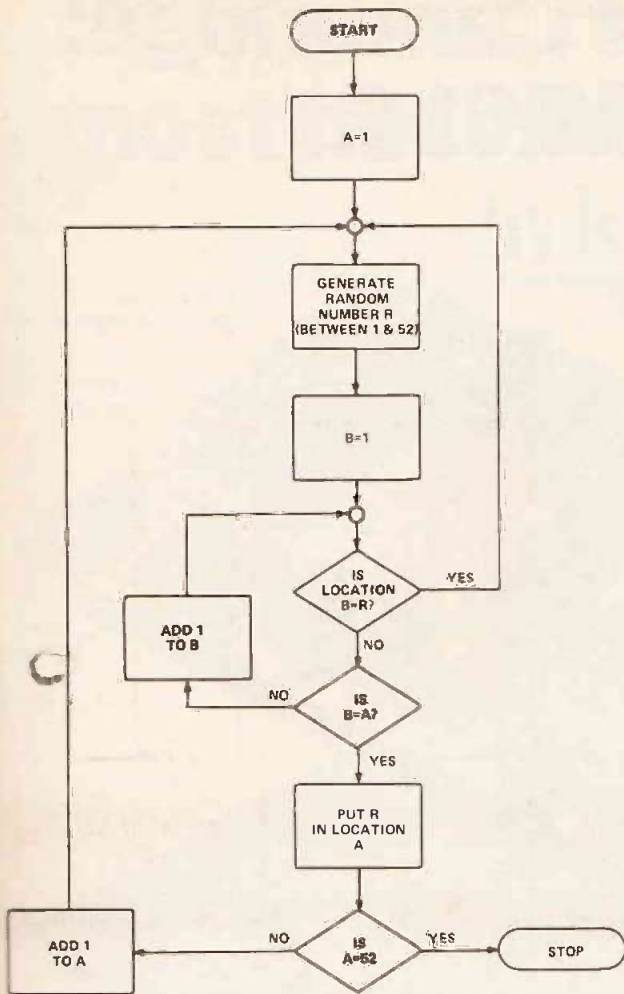

Fig. 4. The new routine.

only two or three locations left to fill, we may have to generate and extensively check many tens of numbers to find one of the few remaining acceptable numbers. If the computer was made to print out each number as it was generated, we would notice a longer and longer time interval elapsing between the generation of consecutive numbers. Problems like this occur frequently when converting algorithms, where a solution which initially appeared to be satisfactory turns out to have some practical difficulties associated with it on closer inspection.

Fig 5 shows the flow chart of an algorithm designed to overcome the previous problem.

It starts by putting 1 in storage locations 1; 2 in location 2; 3 in location 3; and so on until all 52 locations are filled, which in effect lays the cards out in sequence through the pack. It then takes the first location and exchanges its contents with the contents of another randomly chosen location, then the contents of location 2 are exchanged with the contents of a second randomly chosen location; the contents of location 3 are then exchanged with the contents of a third randomly chosen location, and so on until the contents of all 52 storage locations have been randomly exchanged in this manner. You may be a little sceptical as to whether the pack of cards thus generated was truly random. Experiments have, however, convinced us that it is. As you can see, there is never any need to generate more than 52 random numbers, because whatever the number generated

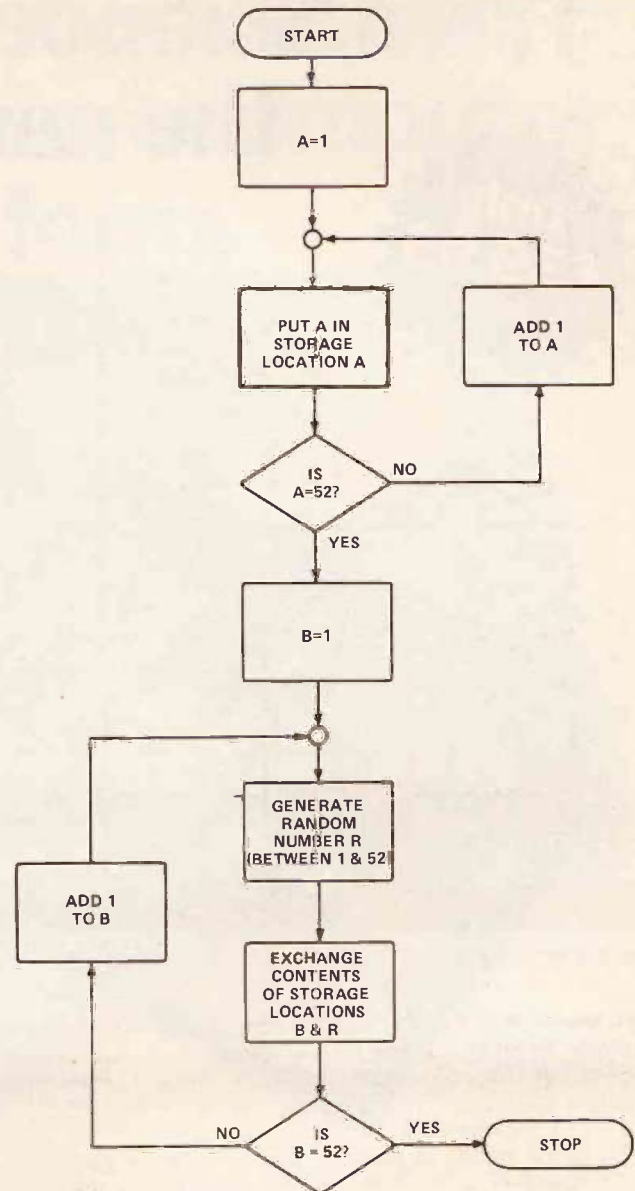

Fig. 5. The British Shuffle?

turns out to be, we are always guaranteed to use it, as it does not matter whether it has been generated before or not. Converting both of these flow charts into programs and running them on a computer, we discovered that this latter algorithm ran approximately ten times as fast, on average, as the first algorithm, so that there is a great saving in computer time used.

Looking through the algorithms and flow charts, you should begin to see that every operation a computer performs has to be very carefully planned and mapped out if a worthwhile program is to result. Although able to operate at extremely high speeds, the computer is merely manipulating pulses of electrical current according to a set of rules which the programmer lays down which, by careful manipulation and interpretation, can be made to have meaning.

Next month we will go on to consider the high-level programming language, BASIC, but do not forget the above routines, for when we have learnt sufficient BASIC, we will be returning to look at them again and see how they can be implemented

CTI

From Science of Cambridge: the new MK 14.

only
£39.95
(+8% VAT)

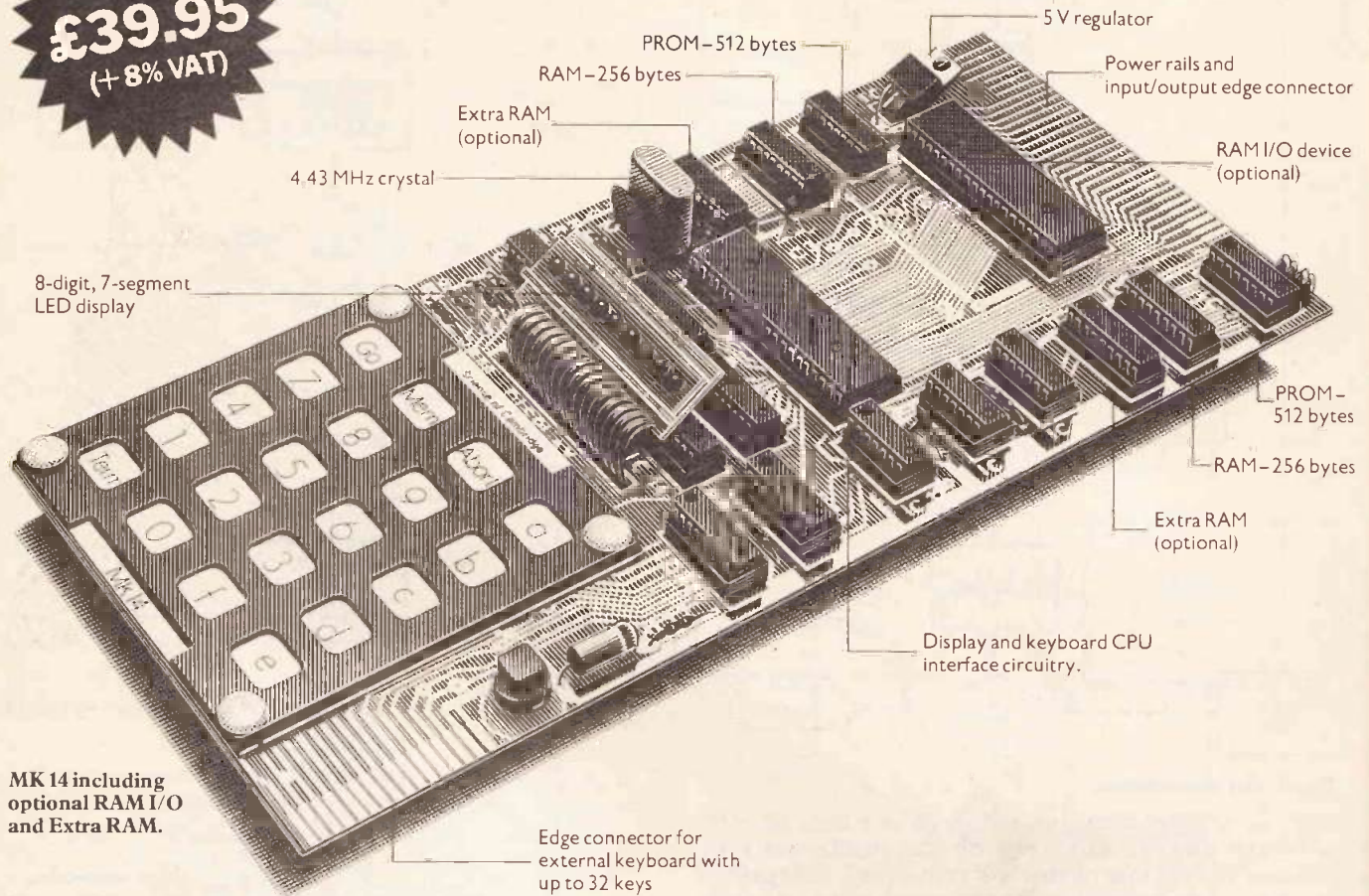

MK 14 including optional RAM I/O and Extra RAM.

MK 14 – a complete computer for £39.95 (+8% VAT)

The MK 14 is a complete microcomputer with a keyboard, a display, 8 x 512-byte pre-programmed PROMs, and a 256-byte RAM programmable through the keyboard.

As such the MK 14 can handle dozens of user-written programs through the hexadecimal keyboard. (20 sample programs are provided in the Manual – which also contains comprehensive building instructions, and instructions on program-writing.)

Yet in kit form (which can be assembled by any fairly experienced kit-builder), the MK 14 costs only £39.95 (+£3.20 VAT, and p&p).

But that's only the start . . .

The memory capacity of the basic kit is surprisingly powerful – but every computer owner, from a schoolboy to a multi-national corporation, soon feels the need for more memory.

With the MK 14, it's yours!

Optional extras include an additional 256-byte RAM, and a 16-line external input/output device (allowed for on the PCB) which give a further 128 bytes of RAM.

And the next step?

The next step is to add your own peripherals!

The first could be a low-cost module which provides an **interface with a standard cassette-recorder**. This means you can use ordinary tape-cassettes for the storage of data and programs.

To get the best from this configuration, you could uprate your system with a **revised monitor** – consisting of 2 replacement PROMs, pre-programmed with sub-routines for the interface, offset calculation and single step, and single-operation data entry.

The second peripheral could be your own **PROM programmer and blank PROMs** to set up your own pre-programmed dedicated applications. (Fusible-link device guarantees program safety.)

All are available now to owners of MK 14 – and remember Science of Cambridge keep you up to date *automatically* with advances in the MK 14 range. A TV interface device is already in the pipeline!

A valuable tool – and a training aid

As a computer, it handles operations of all types – from complex games to digital alarm clock functioning, from basic maths to a pulse delay chain. Programs are in the Manual, together with instructions for creating your own genuinely valuable programs.

And, of course, it's a superb education and training aid – providing an ideal introduction to computer technology.

SPECIFICATIONS

MK 14

- * Hexadecimal keyboard
- * 8-digit, 7-segment LED display
- * 8 x 512 PROM, containing monitor program and interface instructions
- * 256 bytes of RAM
- * 4 MHz crystal
- * 5 V regulator
- * Single 8 V power supply
- * Space available for extra 256-byte RAM and 16 port I/O
- Edge connector access to all data lines and I/O ports

Optional Extras

- * Extra RAM – 256 bytes
- * RAM I/O device

Simplest, most advanced, most flexible microcomputer -in kit form.

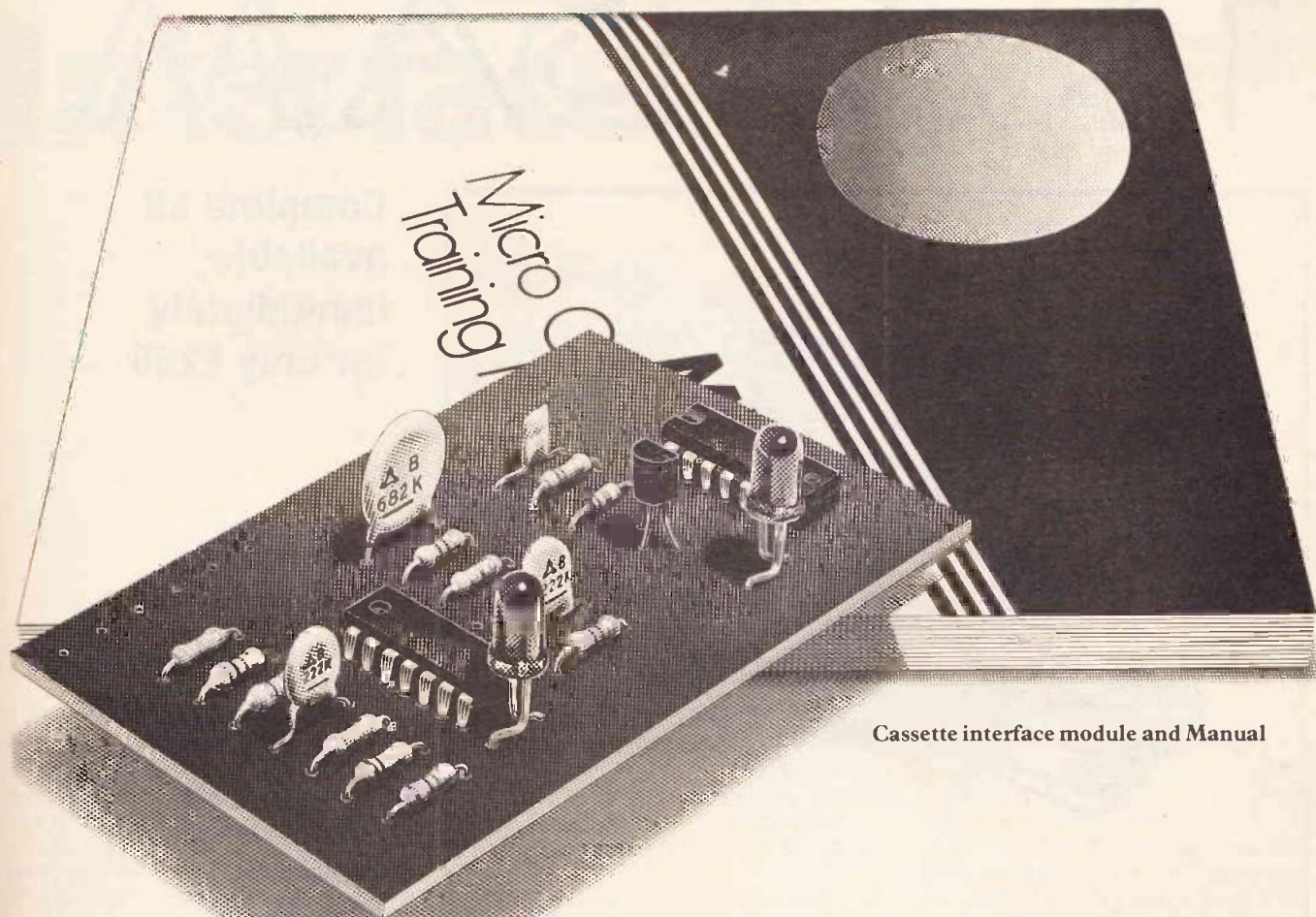

Cassette interface module and Manual

- * Cassette interface module
- * Revised monitor
- * PROM programmer
- * Blank PROMS

Free Manual

Every MK 14 Microcomputer kit includes a Manual which deals with procedures from soldering techniques, through programming and use of RAM I/O to interfacing with complex external equipment. It contains operational instructions and examples for training applications, and numerous programs including math routines (square root, etc), digital alarm clock, single-step, music box, mastermind and moon landing games, self-replication, general purpose sequencing, etc.

Designed for fast, easy assembly

Each 31-piece kit includes everything you need to make a full-scale working microprocessor, from 15 chips, a 4-part keyboard, display interface components, to PCB, switch and fixings.

The MK 14 can be assembled by anyone with a fine-tip soldering iron and a few hours' spare time, using the illustrated step-by-step instructions provided.

How to get your MK 14

Getting your MK 14 kit is easy. Just fill in the coupon below, and post it to us today, with a cheque or PO made payable to Science of Cambridge. And, of course, it comes to you with a comprehensive guarantee. If for any reason, you're not completely satisfied with your MK 14, return it to us within 14 days for a full cash refund.

Science of Cambridge

Science of Cambridge Ltd,
6 Kings Parade, Cambridge, Cambs., CB2 1SN.
Telephone: Cambridge (0223) 311488

To: Science of Cambridge Ltd, 6 Kings Parade, Cambridge, Cambs., CB2 1SN.

Please send me the following, plus details of other peripherals:

- MK 14 Standard Microcomputer Kit @ £43.55 (inc 40p p&p.)
- Extra RAM @ £3.88 (inc p&p.)
- RAM I/O device @ £8.42 (inc p&p.)

I enclose cheque/money order/PO for £ _____ (indicate total amount.)

Name _____

Address (please print) _____

Allow 21 days for delivery.

The exciting
new
Triton computer
from

TRANSAM



Complete kit
available
immediately
for only £286 + VAT

The first
British-designed
home computer kit
with basic IN ROM
and graphics.
The single-board
design makes the
computer easy to
construct, and
when complete,
a very compact and
powerful tool for
home, educational
and industrial use.

Building a better computer wasn't easy —
but we did it.

TRANSAM

HAS A FULL RANGE OF MICROS
AND SUPPORT, PLUS SOFTWARE

TRANSAM

BRINGS YOU "MEMORY BANK"
A FULL MEMORY SERVICE

TRANSAM

TRANSAM COMPONENTS LTD.
12 CHAPEL STREET
LONDON NW1. TEL: 402 8137

NEXT TO EDGWARE ROAD TUBE STATION, MET. LINE,
TRITON COMPUTER IS THE TRADE MAKE OF
TRANSAM COMPONENTS LTD.

All components can be
bought separately and
a fully comprehensive
Triton manual is
available for £5
or send 30p + SAE for
our latest catalogue
and price list.

This unit allows you to program your microprocessor from a prerecorded cassette or to record your own program for later use. Design by Trevor Marshall.

CUTS Cassette Interface

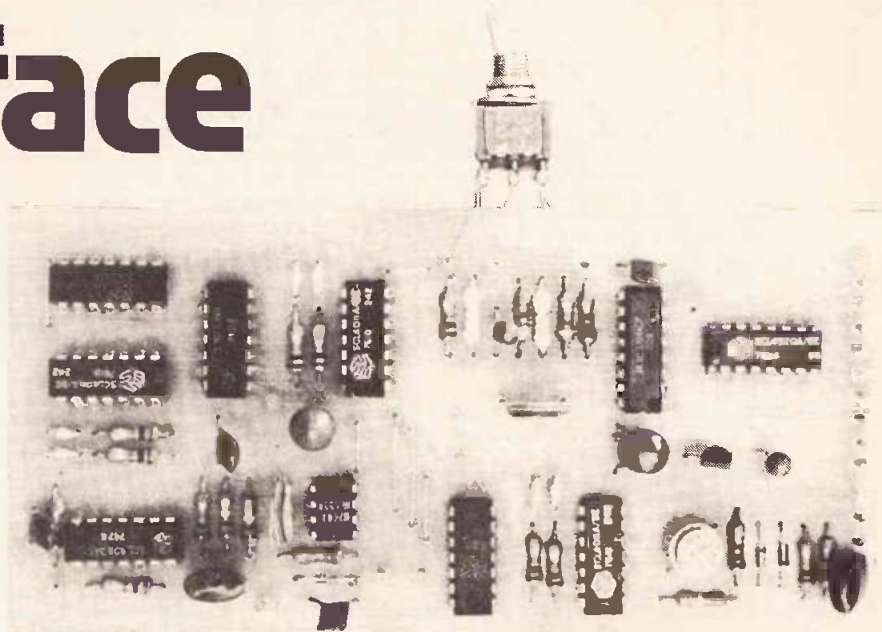

REPEATEDLY TYPING IN programs is not what hobby computing is about. Although most systems start life without any form of off-line mass storage, as more memory is added so more programs are written and the need for some form of storage becomes more pressing. The ideal device for this job is probably the floppy disk, but this is (a) expensive and (b) usually dedicated to one processor or bus structure. Many hobbyists are running several small systems, and a device which is less convenient but more suited to their needs (and pockets) is the humble cassette recorder.

This interface is designed to convert the digital signals from your computer to audio tones and back again, using a standard system called CUTS (Computer Users' Tape System), which is also referred to as the Kansas City or Byte format. This records data at 300 baud, with a logic '1' recorded as eight cycles of 1400Hz and a '0' as four cycles of 1200Hz. A byte of data is recorded as a start bit of logic '0', followed by eight bits of data and two stop bits of logic '1', and this is taken care of by the UART in your computer.

Although the standard is 300 baud, the monitor programs in some kits allow only 110 baud operation, and this interface will work at 110 baud. It can also be run faster (up to 1200 baud) to allow faster program loading.

We have not described a case, as most constructors will wish to mount the board either on the back panel of their computer or in the VDU. Also switching between VDU and cassette will depend upon the user's computer — the ideal situation is to have two UARTs for both VDU and cassette, but many systems (or rather their monitors) do not permit this.

Construction

This is simply assembling the PC board. Take care when handling the ICs as most are CMOS. As the unit will probably be built into a system we have not given any mechanical assembly details. The record/play switch can be mounted remotely if desired.

Alignment

The only adjustments on the unit are the record frequency and the

monostable period. Switch the unit to record and monitor the frequency at any of the baud rate outputs and adjust RV2 to give the correct frequency. Now inject a 1200 Hz tone into the audio input (take off from the baud rate outputs when in the record mode) and adjust RV1 to give a 300us wide pulse at pin 3 of IC4. If an oscilloscope is not available, setting RV1 to mid position should be close enough.

Recording

For best results recording should be done at a relatively low level. We found that about -7VU gave the best results.

Unfortunately the use with a recorder with an automatic level control did not prove satisfactory. This is because the level control logic is designed for music where the peak level is about 10dB or more higher than the average. This cannot cope with a continuous tone without it being recorded at too high a level.

One method which has been suggested to us is to record a high level high frequency tone (about 18kHz) as well as the signal. Theory



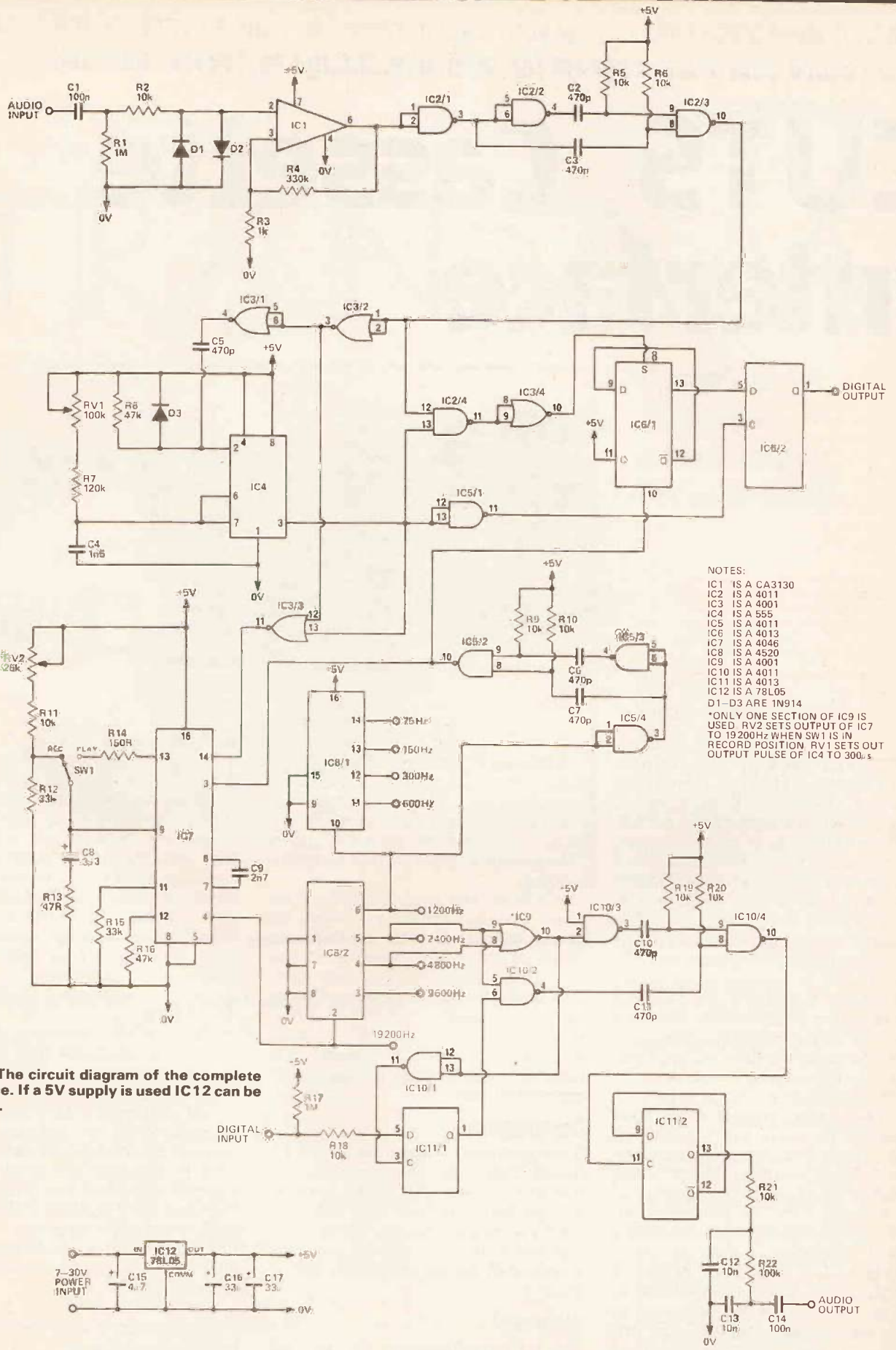

NOTES:
 IC1 IS A CA3130
 IC2 IS A 4011
 IC3 IS A 4001
 IC4 IS A 555
 IC5 IS A 4011
 IC6 IS A 4013
 IC7 IS A 4046
 IC8 IS A 4520
 IC9 IS A 4001
 IC10 IS A 4011
 IC11 IS A 4013
 IC12 IS A 78L05
 D1-D3 ARE 1N914
 *ONLY ONE SECTION OF IC9 IS USED RV2 SETS OUTPUT OF IC7 TO 19200Hz WHEN SW1 IS IN RECORD POSITION RV1 SETS OUT OUTPUT PULSE OF IC4 TO 300µs

Fig. 1. The circuit diagram of the complete interface. If a 5V supply is used IC 12 can be deleted.

How It Works

This unit records digital information on tape in serial form using two tones, 2400 Hz for a "1" and 1200 Hz for the "0". The standard transmission rate is 300 baud but it will work equally well at 600 baud. The designer has operated his unit at 1200 baud with success but with only one cycle of 1200 Hz per bit it is more prone to dropout, etc.

Decoder

We will start the explanation of how it works by assuming you have a prerecorded tape. The output of the tape recorder (alternate tones of 1200 and 2400 Hz) is "squared up" by IC1 which is connected as a schmitt trigger with R3 and R4 providing the necessary positive feedback.

The gates IC2/1, IC2/2 and IC2/3 are used to generate a positive pulse about 3 μ s wide on both the leading and trailing edges of the output of IC1. This gives a series of pulses at either 2400 Hz or 4800 Hz (417 μ s or 208 μ s period).

The pulse chain triggers the monostable IC4 which is 300 μ s wide. If a second trigger pulse occurs before the 300 μ s period (as it will if the input is 4800 Hz) the second pulse is simply ignored. The input pulse chain is gated with the monostable output in IC3/3, the resultant output being pulses at 2400 Hz

whether the input frequency is 2400 or 4800 Hz.

These pulses are used for the reference for the phase locked loop (PLL) IC7. This IC contains a phase detector and a voltage controlled oscillator. The output of the oscillator is divided by 2³ in IC8. After dividing by 2⁴ (16) IC5/2, IC5/3 and IC5/4 are used to generate 3 μ s wide pulses on both leading and trailing edges and this output is the second input to the phase detector in IC7. The output of the phase detector (pin 13) is used to control the oscillator (input is pin 9) and the two pulse chains are equalised in frequency and phase. Using this technique the tape speed can be varied by up to \pm 20% and the PLL will track it. The outputs of IC8 can be used to control the UART in the computer. If the UART's own clock is used the allowable tape speed variation is \pm 5%.

To decode the pulse chain into "1" and "0" and to ensure correct phasing, IC2/4, IC3/4, IC5/1 and IC6 are used. The monostable IC4 is triggered at 2400 Hz, and its output clocks the D input of IC6/2 into the output. IC6/1 is used as an R-S flip flop being "set" if a pulse from IC2/3 occurs during the "mono" period (if the input is high frequency) it is reset every 417 μ s by IC5/2. However, the information is clocked

into IC6/2 before the reset pulse occurs. If the input is only a 1200 Hz tone the set pulse does not occur and a "0" is strobed into IC6/2. An examination of the timing diagram in fig. 1 will help clarify the sequence.

Encoder

The encoder is a little more complex than needed for 300 baud, but it allows operation at 600 or 1200 baud if needed. The output of IC9, which is a non-symmetrical 2400 Hz, triggers a 3 μ s monostable IC10/4 which then toggles IC11/2 giving a 1200 Hz square wave output. However, if the "data input" is a "1", IC11/1 is toggled to give a "1" at pin 1 which enables IC10/2. This then triggers the monostable IC10/4 midway between the pulses due to IC9. This then toggles IC11/2 at twice the rate to give 2400 Hz output. The clocking of the data input into IC11/1 is about 100 μ s out of phase with the rest of the timing to give time for the UART to settle, eliminating any errors due to propagation delays.

The phase locked loop IC is used only as an oscillator in the transmit mode and the VCO input is switched to a preset voltage giving the correct frequency.

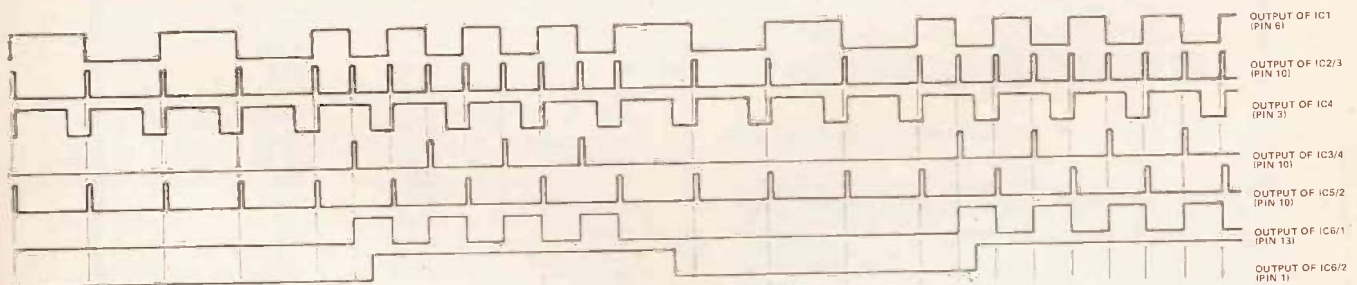

Fig. 2. The sequence of events in the decoder when receiving a '0,1,0,1' input.

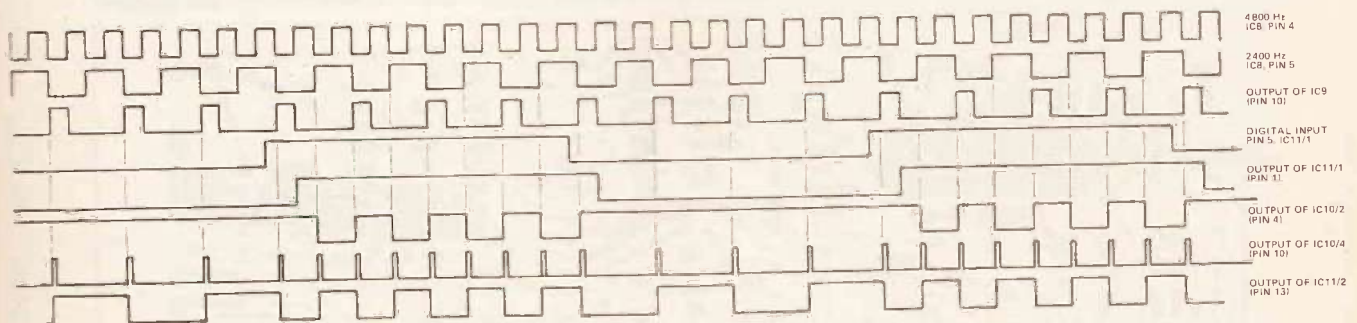

Fig. 3. The encoder waveforms when transmitting a '0,1,0,1.'

is that this tone will adjust the automatic level control while being too high to be reproduced. However it can beat with the bias oscillator causing more problems than it

solves.

We therefore recommend that the unit be used only with a recorder with a manual recording control.



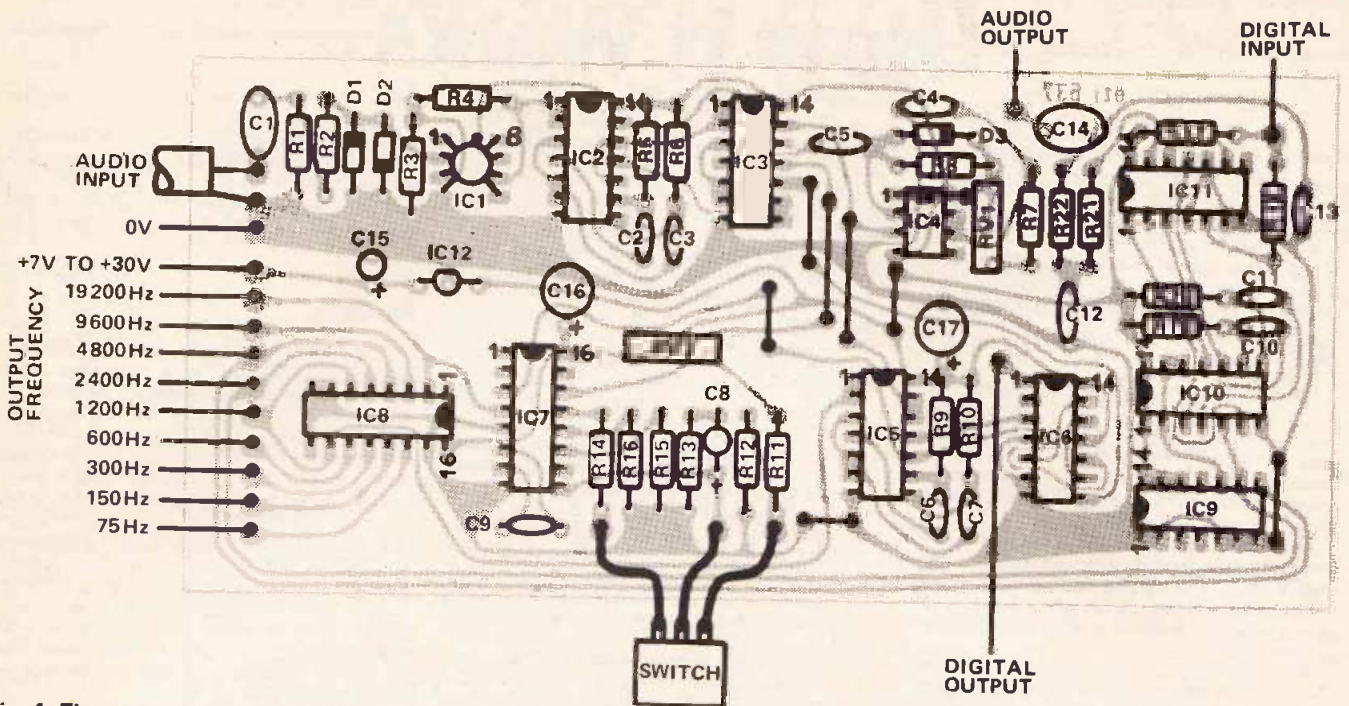

Fig. 4. The component overlay. When using a 5V supply leave out IC12 and add a link between the two outside holes. C15 can also be deleted.

Parts List

RESISTORS

(All 1/2w 5%)

R1	1M
R2	10k
R3	1k
R4	330k
R5,6	10k
R7	120k
R8	47k
R9-R11	10k
R12	33k
R13	47R
R14	150R
R15	33k
R16	47k
R17	1M
R18-R21	10k
R22	100k

POTENTIOMETERS

RV1	100k trim
RV2	25k trim

CAPACITORS

C1,14	100n polyester
C2,3,5,6,7,10,11	470p ceramic
C4	1n5 polyester
C8	3u8 25V electrolytic
C9	2n7 polystyrene
C12,13	10n polyester
C15	4u7 35V electrolytic
C16,17	33u 10V tantalum

SEMICONDUCTORS

IC1	CA3130
IC2	4011
IC3	4001
IC4	555
IC5	4011
IC6	4013
IC7	4046
IC8	4520
IC9	4001
IC10	4011
IC11	4013
IC12	78L05
D1-D3	1N914

MISCELLANEOUS

PCB	as pattern
SW1	SPDT toggle

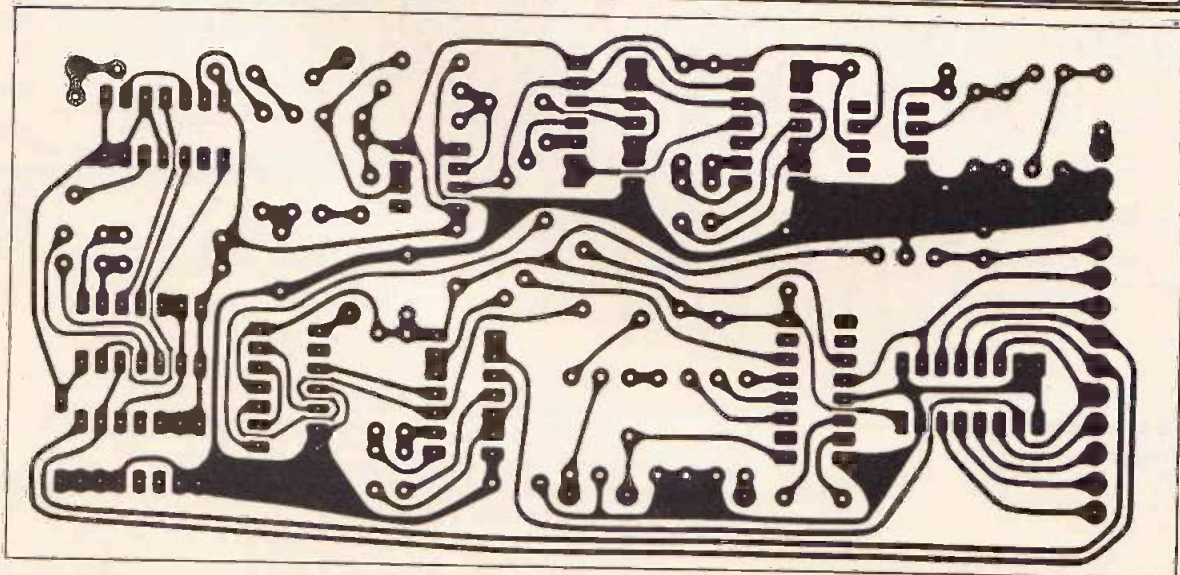

TRITON

John Coll, PCW consultant and well known to the computer hobbyist gives his impressions of the TRITON

I've had an early production model of the Triton for some time and I've been most impressed with it and with ETI's approach to the project.

On the hardware side it's clear that the designer Mike Hughes is a professional. The PCB is cleanly designed and good provision has been made for expansion at a future date. The addition of extra memory and of peripherals like printers and floppy disks will be a straight forward process. Whilst economy has been very much borne in mind. There has been no skimping, everything you need is provided to make a simple useful computer using a normal TV set as a display. The fact that where tracks have to go near IC pins, the tracks have been put on the upper side of the board — away from the constructors soldering iron — is typical of the attention to detail which is evident throughout the design.

On the software front the 2K basic interpreter is Li Chen Wang's Palo Alto tiny BASIC which has been around for some time and is therefore pretty much bug free, ie it works.

The monitor on the other hand is very much a version one — it works but could be improved considerably. However, this does not worry me in the slightest because all the software is in EPROM and therefore can be easily and cheaply altered. It is difficult to explain just how important that is — it means that users will be able to return the monitors to Transam and get them reprogrammed with the latest software for a very reasonable sum. It also means that if you want to use the computer for something else you can remove the BASIC and use the whole 4K of EPROM for your special application. This makes the machine potentially important in the process control field.

The documentation is good, however it seems only fair to say that the TOTAL novice would probably find it difficult to diagnose and repair any obscure fault. However, Transam's 'Get it going' service should deal with that in a satisfactory way. The availability of full source listings for both the monitor and BASIC will be useful in specialist applications as well as for the enthusiastic beginner.

It is clear that ETI are determined to 'Get this one right' and to support it in the future with further software and hardware.

I have no hesitation in recommending this kit to you.

LIVERPOOL'S COMPUTER SHOP

Quality C15 cassettes for your PET, Apple, TRS80, NASCOM 1, etc.

10 cassettes for £4.75 including P. & P., V.A.T., labels and library cases

Science of Cambridge MK14. Socket Set. 5 × 14 pin, 7 × 16 pin, £3.84 including P. & P. and V.A.T. Power Supply. £4.86 including P. & P. and V.A.T.

Barclaycard and Access accepted.



MICRODIGITAL LTD.
25 BRUNSWICK STREET
LIVERPOOL L2 0BJ
Tel: 051-236 0707

MICRODIGITAL



NEWBEAR COMPUTING



Announcing the **SYM-1**:-from Synertek
(formerly VIM-1)

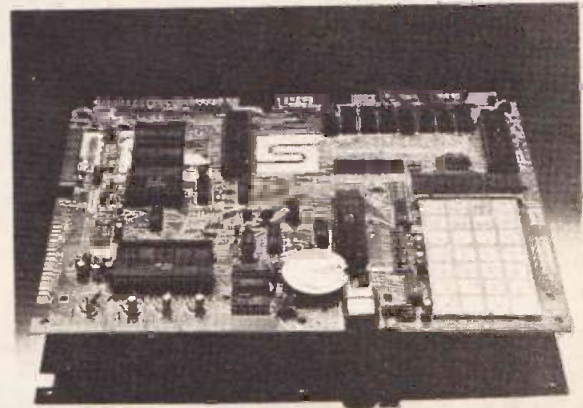

- ★ Fully assembled and tested
- ★ KI M.I. compatible.
- ★ High speed cassette interface (2400 baud)
- ★ 1K byte storage, expandable on board to 3K byte
- ★ 4K byte ROM Monitor
- ★ Fully expandable and much much more

£199.00 plus 8% VAT £1 00 postage and packing

For further details Visit Newbear Computing Store, 2 Gatley Road Cheadle, Cheshire, 061-491 2290 Or visit, or write to Newbear Computing Store, 7 Bone Lane, Newbury, Berks. 0635 49223. Send for Catalogues of Hardware Components, Literature and Software.

L.P. ENTERPRISES

Room ETI/11
313 Kingston Road, Ilford
Essex IG1 1PJ, England
01-553 1001

From the representatives in Europe... for America's leading Micro-computer magazines and books, for the hobbyist, educationist and professional alike, we bring you a little light browsing!
Reading maketh a full man... Francis Bacon (1561-1626)

Tick or indicate quantity ordered.	
From Adam Osborne Associates	
	Price UK
INTRODUCTION TO MICROCOMPUTERS	
Volume 0: The Beginners Book	£5.95
Volume 1: Basic Concepts	£5.95
Volume 2: Some Real Products (Revised Late 1977)	£11.95
6800 Programming for Logic Design	£5.95
8080 Programming for Logic Design	£5.95
Z80 Programming for Logic Design	£5.95
8080A/8085 Assembly Language Programming	£6.95
6800 Assembler Language Programming	£6.95
Some Common BASIC Programs	£5.95
BUSINESS PROGRAMS IN BASIC	
Payroll With Cost Accounting	£9.95
Accounts Payable & Accounts Receivable	£9.95
General Ledger (Available from late summer 78)	£9.95
From Scelbi Computer Consulting Inc.	
6800 Software Gourmet Guide & Cookbook	£7.95
8080 Software Gourmet Guide & Cookbook	£7.95
8080 Programmers Pocket Guide	£2.25
8080 Hex Code Card	£2.25
8080 Octal Code Card	£2.25
8080 Guide and One 8080 Code Card	£4.20
8080 Guide and Both Code Cards	£6.00
Understanding Microcomputers & Small Computer Systems	£7.95
SCELBI 'BYTE' Primer	£9.95
8080 Standard Assembler (In Block Format)	£15.95
8080 Standard Editor (In Book Format)	£9.95
8080 Standard Monitor (In Book Format)	£9.95
From Peoples Computer Company	
Reference Books of Personal & Home Computing	£4.95
What to Do After You Hit Return	£7.00
Dr. Dobbs Journal Volume 1	£10.00
*From Kilobaud/73 Magazine Inc.	
Hobby Computers Are Here	£3.95
New Hobby Computers	£3.95
From Dymax Inc.	
Instant BASIC by Jerald R. Brown	£4.95
Your Home Computer by James White	£4.95
My Computer Like Me... When I Speak	
BASIC By Bob Albrecht	£1.65
Games With A Pocket Calculator by Thiagarajan & Stilovitch	£1.75
Games, Tricks and Puzzles For a Hand Calculator by W. Judd	£2.49
*From BYTE Publications Inc.	
Paperbytes:	
Tiny Assembler for 6800 Systems	£5.75
Bar Code Loader for 6800, 8080, Z80 & 6502 Micros	£1.75
Best of Byte Volume 1	£8.95

Tick or indicate quantity ordered	Price UK	Price Overseas If Different
* From Creative Computing Press		
Best of Creative Computing Volume 1	£6.95	
Best of Creative Computing Volume 2	£6.95	
BASIC Computer Games		
(A revised 101 BASIC Games)	£5.50	
The Colossal Computer Cartoon Book	£3.95	
Computer-Rage (A new Board Game)	£6.95	
Artist and Computer	£3.95	
* From Everyone Else		
Magazine storage boxes (hold 12 minimum)	£1.25	
Sybox: Microprocessors from Chips to Systems		
by R. Zacs	£7.95	
Sybox: Microprocessors Interfacing Techniques		
by R. Zacs	£7.95	
Dilithium: Home Computers		
Volume 1: Hardware	£6.50	
Dilithium: Home Computers		
Volume 2: Software	£5.95	
Getting Involved With Your Own Computer	£4.75	
The Z80 Microcomputer Handbook	£7.50	
TV Typewriter Cookbook by Don Lancaster	£7.50	
TTL Cookbook	£7.95	
CMOS Cookbook	£7.95	
IC Timer Cookbook	£7.50	
IC OP-AMP Cookbook	£9.50	
RTL Cookbook	£4.25	
Computer Programs that Work (in BASIC)	£2.55	
* From Basic Software Library		
(from Scientific Research Instruments)		
Vol 1: Business and Personal Booking Programs	£17.50	
Vol 2: Maths and Engineering Programs	£17.50	
Vol 3: Advanced Business Programs	£26.50	
Vol 4: General Purpose Programs	£7.95	
Vol 5: Experimenters Programs (General Purpose)	£7.95	
Vol 6: General Ledger Program	£32.50	
Vol 7: Professional Programs	£26.95	
Magazines: Back Issues		
Personal Computing		
Interface Age	£1.75	
Dr. Dobbs Journal	£2.25	
Computer Music Journal	£1.75	
Peoples Computers	£2.50	
*BYTE	£1.75	
Creative Computing	£2.25	
Calculators & Computers	£1.75	
ROM	£1.75	
Kilobaud	£1.75	
73	£2.25	
	£2.00	
MAGAZINES: Subscriptions		
Personal Computing (Twelve Issues Yearly)	£16.00	£17.00
Interface Age (Twelve Issues Yearly)	£20.00	£20.50
Dr. Dobbs Journal (Ten Issues Yearly)	£13.00	£13.50
Computer Music Journal (Four Issues Yearly)	£8.50	£9.00
Peoples Computers (Six Issues Yearly)	£8.00	£8.50
Kilobaud (Twelve Issues Yearly)	£20.00	£21.00
BYTE (Twelve Issues Yearly) via USA	£15.00	
BYTE (Twelve Issues Yearly) via UK	£21.00	
Creative Computing (Six Issues Yearly)	£8.50	£9.00
Creative Computing (Twelve Issues Yearly)	£16.00	£17.00
Calculators & Computers (Seven Issues Yearly)	£10.00	£10.50
73 (Twelve Issues Yearly)	£20.00	£21.00

HOW TO ORDER

Please note our prices include postage and packing, but not insurance, if wanted add 12p for every £10 of books ordered. Make cheques, PO's etc payable to

L.P. Enterprises
CREDIT CARDS accepted
BARCLAYCARD VISA/ACCESS
DINERS CLUB/AMERICAN EXPRESS

Phone 01-553 1001 for Credit Card orders (24 hour service)

Due to fluctuations of the dollar, prices are subject to change

Send to address above for the attn. of David, Dept. ETI/11
Indicate Payment Method:

My cheque, P.O., I.M.O. is enclosed in Sterling on U.K. Bank

Charge to Barclaycard Visa/Access/Diners/American Express

Credit Card No. _____ Expiry date _____

Name _____

Address _____

Signature _____

All Orders must be Prepaid
Total Enclosed £

POSTCODE _____

All publications are published in U.S.A. and shipped air-freight by L.P. Enterprises. In unusual cases, processing may exceed 30 days
*BYTE subscriptions are processed IN USA and are air-freighted & posted from Amsterdam and will take 3 months to start.

U.K. Subscriptions start within three weeks
TRADE ENQUIRIES WELCOME

ETI/11/78

East Coast Report

Proclaimed as the largest show ever, Personal Computing '78 was held in the Philadelphia Civic Centre, from the 24th to 27th of August. Computing Today roving reporter Jim Perry was there with his box brownie.

With more than 300 stands and over 100 exhibitors the PC '78 show certainly was large by any standards! To celebrate its third birthday the show had moved to the Philadelphia Civic Centre from its birthplace in Atlantic City. The move of venue was brought about by the tremendous growth in attendance — Atlantic City was just too small for this year's show!

The promoters of the event claim that just over 20 per cent of the American Personal Computer Market is within 2 hours drive of Philadelphia, this is probably because New York is just 2 hours away.

Amongst the many exhibitors there were surprisingly few new products — well, new to the American market at least — most of the products would be new in the UK if available here. With companies such as Heathkit, Radio Shack (Tandy) and Southwest Technical Products in attendance, it was Commodore that was conspicuous — by its absence.



To complement the exhibition the organisers had arranged more than 80 hours of seminars, on everything from business systems to computer games. A good point was that all the daytime events were included in the exhibition admission fee. Other activities included a show of computer generated art, a computer music evening and traditional Saturday night banquet (read booze up). ▶

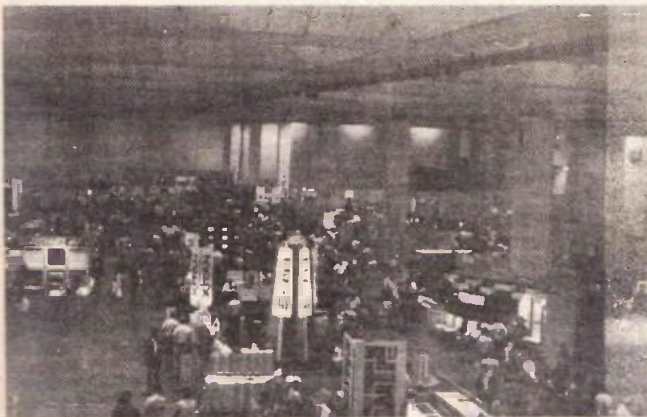

General view of the main exhibition area, early on the first day.



Not quite what you expect at a Personal Computer Show, but a lot of people were looking for complete systems for small businesses.



Software for the TRS 80 was available from many suppliers. This stand is demonstrating a chess recorder program.



The RCA stand was dedicated to their COSMAC VIP, the two small boards plugged into the back are the new music synthesiser and drum machine attachments.



Computer music was the theme on the SOL stand. The interface, between man, machine and music is one of the exciting growth areas.

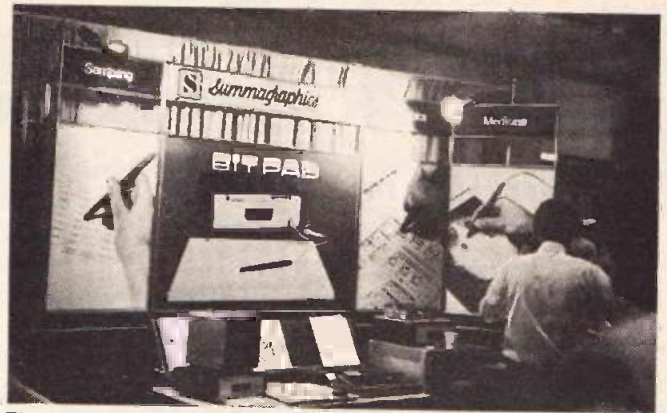

The Bit Pad is a rather nice (but expensive) device for turning freehand into computer input.

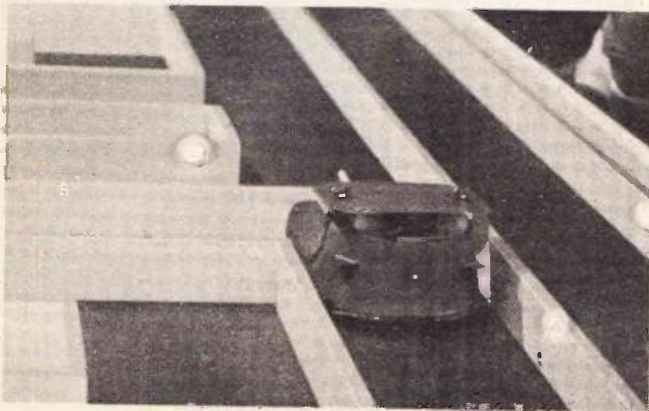

Is it a bird? Is it a plane? No, it's a Micro Mouse! The second trials for the IEEE/Spectrum Micro Mouse Maze competition were held during the exhibition — this MPUed mouse made it through the maze in 4 minutes 45 seconds.



Computalker Consultants did a roaring trade with their versatile speech synthesis units.



The message centre used SWTP equipment to keep everybody up to date via several monitors.



The Radio Shack (Tandy) area was equipped with 12 TRS 80 systems, the complete range of peripherals (printers, floppies etc) was also on continuous demonstration.



Part of the British contingent, Chris Carey and Jim Wood from Comp Computer Components were scouting for new products to unleash on the UK market.



Exidy were demonstrating the Z80 based Sorcerer Computer — a nice feature of this machine is the plug in BASIC, which can be replaced with various other languages virtually instantly.

The TRITON software has some interesting facilities — we take a look at the whole package.

TRITON Software

—BASIC

The TRITON BASIC Interpreter was designed to run on small 8080/Z80 micro processor systems. It contains many of the common BASIC commands and most small BASIC programmes will be easily converted to run on the Triton.

Variables

All variables and numbers are stored as 16 bit integers and therefore must lie in the range —32767 to 32767. There are 26 variables each denoted by a single letter A to Z. There is 1 array denoted by @, this array is automatically dimensioned to make use of any memory space left unused by your BASIC Programme. The number of bytes of memory space in this array can be obtained at RUN time using the SIZE function.

Functions

There are three functions available.

- ABS(X) which gives the absolute value of the variable X.
- RND(Y) which gives a random number between 1 and Y inclusive.
- SIZE which gives the number of bytes left unused by your programme.
Hence the maximum index for the array @ () is SIZE/2.

Arithmetic Operators

- + Add
- Subtract
- * Multiply
- / Divide

+, —, * and / operations must result in a value in the range —32767 to 32767 and as they are also integer, any division is rounded down. E.G. 5/2 gives 2. 2/3 will give 0.

Compare Operators

- > greater than
- < less than
- = equal to
- ≠ not equal to
- >= greater than or equal to
- <= less than or equal to

The compare operators are usually used with the IF command but can also be used in expressions. The result of any comparison is 1 if true and 0 if not true (false).

Expressions

Expressions are formed from number, variables and functions.

E.G. 10 LET A = 10 A is set to 10
20 LET B = A B is set to contents of A ie 10

Arithmetic operators are used in expressions and are evaluated from left to right, except that * and / are always evaluated first.

Spaces between numbers, variables and functions are ignored. Spaces inbedded in command words are not allowed.

Parentheses can be used to change the order of evaluation.

Parentheses can be nested, the maximum depth being limited by the size of the stack.

Conditional operators are usually found with the IF command

```
10 IF A = 1 B = B + 1
```

In this statement when A is equal to 1 the expression B = B + 1 is executed and one is added to the contents of B.

Conditional expressions can be combined to form multiple conditions and can also be used in arithmetic expressions.

Statements

A BASIC statement consists of a statement number between 1 and 32767 followed by one or more commands. If a statement contains more than one command, each command is separated by semi colon ;. The statement is ended by a carriage return.

```
10 LET A = 10
20 LET B = A
30 LET C = A + B
```

This can be written

```
10 LET A = 10; LET B = A; LET C = A + B
```

It should be noted that the latter method will be harder to change or correct.

The commands GOTO, STOP and RETURN must be the last command in any statement.

Commands

The following commands are available in the TRITON BASIC L4.1

LET

LET is used to set a variable to the result of an expression.

```
10 LET A = 10 The variable A is set to 10
```

```
20 LET B = (A-1)
```

```
*2
```

The variable B is set to the result of the expression (A-1)*2 i.e. 18

```
30 LET @(3)
```

```
= B/3
```

The fourth element of the array @ is set to 6 (The first element is @(0))

The expression need not be an arithmetic expression.

```
10 LET C = A ≠ B
```

If A equals B, C will be set to zero
If A is not equal to B, C will be set to one

The LET command can be used to set several variables

```
10 LET A = 1, B = 2, C = 3
```

each part being separated by a comma ,

We can therefore rewrite an earlier example.

```
10 LET A = 10, B = A, C = A + B
```

Rem

The REM (Remark) Command allows the programmer to comment his programme. The interpreter will ignore the rest of the line.

```
100 REM THIS IS THE START OF THE SUB-ROUTINE Y = A*A + B
```



Print

The PRINT command is used to print numbers, variables, expressions, and text.

- 10 PRINT A will print the contents of variable A
- 10 PRINT A*2 prints twice the contents of variable A
- 10 PRINT 'THIS IS A TITLE' prints THIS IS A TITLE

Several variables, etc. can be printed at once. Each item to be printed is separated by a comma.

- 10 PRINT A,B,C will print the contents of A followed by B and C on the same line.

Text can be used to qualify printout.

- 10 PRINT 'THE RESULT IS', A

Text can be contained by either single or double quotes, this allows the other type of quote to be printed.

- 10 PRINT 'ABC"CBA', "123'321" will print ABC"CBA123'321

Numerical values are printed with leading spaces (Right Justified) in a field of width 8 characters. The field width can be altered using a # sign followed by the new width (i.e. # 3 gives a width of 3).

The field width will then remain effective until another # or the end of the current PRINT statement.

- 10 PRINT A, #3, B, #1, C will print A in a width of 8 characters. B in a width of 3 and C in a width of 1.

#1 will result in C being printed Left Justified and any following printout will be shifted to the right if C

is greater than 9

The field width can also be an expression
PRINT # I, A will print A in a field width equal to the contents of variable I

The maximum field width is 63.

Note that negative numbers require an extra character in the field width for the minus sign.

Extra spaces can be generated by repeated commas.

- PRINT # 3,A,,B will print a 3 character A, 2 spaces and a 3 character B

Several PRINT statements can be made to print on the same line by ending the statement with a comma.

Graphic characters can be printed using the PRINT statement. The description of the graphics font lists those Graphics which can be contained in quotes and will result in graphics being printed.

The PRINT statement can also be used to issue cursor control characters

- 10 PRINT †H will issue a control H which will backspace the cursor
- 10 PRINT †I will issue a control I which will forward space the cursor
- 10 PRINT †J moves cursor down
- 10 PRINT †K moves cursor up
- 10 PRINT †L will clear the whole screen and reset the cursor. Note that this command must be followed by a delay before the next command (FOR I= 1 TO 250; NEXT I)
- 10 PRINT †M will reset the cursor to the start of the line.

Input

The input command is used to read an expression

ANNOUNCING THE MICROS

JOIN THE MICRO REVOLUTION!

£550 for a Z80 based microcomputer, built and tested

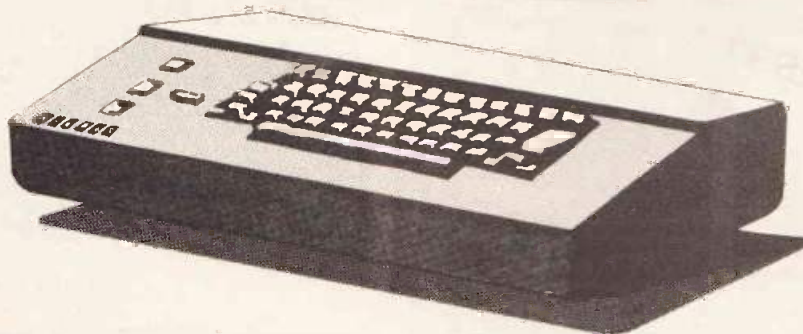

- * Includes CPU, ROM, RAM, TV and Audio cassette interface, UHF modulator, ASCII keyboard, power supplies and cabinet.
- * Connect to domestic TV or video monitor to complete the system.
- * 48 x 16 character video matrix
- * Hard copy on teletype
- * Also available in kit form £470, or 5 kitpacks at £95 each
- * Designed for educational establishments, personal computing and small business users
- * Load and dump programmes on unmodified cassette recorder
- * 57 key contactless ASCII keyboard
- * British designed and built
- * Credit terms available

THE MICRONICS COMPANY

1, STATION ROAD TWICKENHAM MIDDLESEX

PART OF THE MICRO REVOLUTION

Prices exclusive of VAT and carriage

BASIC

from the Keyboard. Normally the keyboard input is just an integer value between -32767 and 32767.

10 INPUT A When this statement is executed, the BASIC will first print A followed by a space and then wait for keyboard input. The input is terminated by carriage return. The input is then stored in variable A

10 INPUT A,B will print A,space,then wait for input, it will then print B, space, and wait for input again.

Instead of just allowing the machine to prompt you with the variable, it is much better to ask a specific question. This is done by enclosing the text of the question in quotes.

10 INPUT 'HOW MANY EGGS HAVE YOU LEFT?'

The machine will print HOW MANY EGGS HAVE YOU LEFT? and then wait of a number to be typed in. If during RUN time, the typed input is not a valid expression, the prompt will be repeated and then the machine will wait again.

It is also possible to reprint only part of the prompt.

10 INPUT 'WHAT IS ', 'A + B?' 'C', 'A - B?' 'D'

The first time the printout will be WHAT IS A + B? and after an invalid input it will just print A + B?

The BASIC interpreter uses its expression evaluation routine to decode the input and therefore the programmer or user can enter an expression using variables already set up.

10 LET A = 3, B = 2

20 INPUT C

30 PRINT C

Instead of entering a value for C, the user can enter

an expression such as A + B, the expression will then be evaluated by the interpreter and the result 5 stored in the variable C. The machine will then print 5.

It is also possible to enter single characters as a reply by making use of the expression input.

10 LET Y = 0, N = 1

20 INPUT 'DO YOU WANT TO CONTINUE? Y OR N' A

30 IF A = 1 STOP

If the user replies Y, A will be set to the contents of Y i.e. zero. If the user replies N-A will be set to 1 and the programme will STOP.

If

The IF command is used to compare expressions, using the compare operators. If the result of this comparison is true (non zero) the rest of the statement is executed. If the result of the comparison is false (zero), the rest of the statement is skipped and execution resumes on the next statement.

10 IF A = 0 PRINT 'A IS ZERO'

The machine will print A IS ZERO only when A is zero.

Note that unlike other BASIC interpreters and compilers, the word THEN is not used.

Either side of the compare can be an expression.

10 IF A = B * 2 PRINT 'A IS TWICE B'

20 IF A * 3 = B * 2 PRINT 'A = B * 2 / 3'

A compare operator need not be used in the IF statement but this practice should be avoided where possible as it can make the programme very hard to follow.

10 IF A = 1 PRINT 'A IS NOT ONE'



A more interesting way to learn

what is a microprocessor?

If you are considering buying a Micro-computer, Development System, or just want to learn more about this exciting technology, then this short introduction to Microprocessors is for you. Comprising of a 72-page book keyed to over two hours of cassette tapes the many aspects of Microprocessors are explained, including Binary and Hexadecimal counting, Internal structure, Operation, Programming Techniques, Devising a program, etc. Learn at your own pace with this valuable addition to your reference library

To Technical Book Services
P.O. Box 79
Maidenhead, Berks SL6 2EG

ORDER FORM

Please send me ... copy/copies of What is a microprocessor?
@ £10.75 each inclusive. I enclose remittance £.....

Name
(Print Please)

Address

Registered office 21, Mincing Lane, London EC1 Registered No 12225

the PRINT command is only skipped when the result of the expression in the IF command is zero.

```
Several commands can follow the IF command  
10 IF A=0 PRINT 'A IS ZERO'; GOTO 50
```

When A is zero, the machine will print A IS ZERO and then jump statement 50.

GOTO

You will probably be fairly familiar with the GOTO command already as it has appeared in several of the examples for the other commands.

The GOTO command is used to break the sequential processing of the BASIC interpreter and cause the interpreter to jump either forward or backwards to the specified statement number.

```
50 GOTO 10
```

When the interpreter executes this statement it will jump back up the program to statement 10 and continue its processing from statement 10.

Again, the statement number following the GOTO can be an expression.

```
20 GOTO A*2
```

Will jump to the statement number calculated from the expression A*2. If the expression gives a non-existent statement number the BASIC will give an error report.

Using a simple expression for a GOTO is useful where different routines may be required as a result of an input.

Another method of using a computed GOTO is to use the array variable and index it.

```
10 LET @(1)=100, @(2)=200, @(3)=100,  
@ (4)=25
```

```
20 INPUT I
```

```
30 GOTO @(I)
```

If the input for I is 1 the interpreter will jump to statement 100

```
for I=2 it will jump to 200
```

```
for I=3 to 100 again
```

```
for I=4 to 25
```

It is advisable when using the computed GOTO to check the variable for valid values, ie in the above example it would be advisable to insert

```
25 IF I < 1 GOTO 20
```

```
27 IF I > 4 GOTO 20
```

This will only allow an input of 1 to 4, any other input will result in a repeat request for input.

Gosub and return

The GOSUB command although similar to the GOTO command, is used to exit from a statement and jump to a routine starting at the specified statement number. Execution continues from the specified statement number until a RETURN command where upon the BASIC returns to the command following the original GOSUB.

```
10 PRINT 'LETS EXECUTE ROUTINE 100'
```

```
20 GOSUB 100; PRINT 'WE HAVE NOW  
RETURNED'
```

```
30 STOP
```

```
100 PRINT 'THIS IS ROUTINE 100'
```

```
120 PRINT 'I WILL RETURN WHEN I HAVE  
FINISHED'
```

```
130 RETURN
```

This will result in the following printout

```
LETS EXECUTE ROUTINE 100
```

```
THIS IS ROUTINE 100
```

```
I WILL RETURN WHEN I HAVE FINISHED
```

```
WE HAVE NOW RETURNED
```

The GOSUB 100 command causes the BASIC to jump to statement 100 but also to remember where it is in statement 20. It now executes from statement 100 until it reaches the RETURN command. It then

returns to statement 20 and continues processing it.

For and next commands

The FOR command is a very powerful command. It is used to make the BASIC interpreter loop 'FOR' a specified number of times, the end of the loop being defined by the NEXT command.

```
10 FOR I=2 TO 10 STEP 2
```

```
20 PRINT I
```

```
30 NEXT I
```

I is set to 2 when the FOR statement is first encountered. It will then remain at 2 until the NEXT command is encountered. On reaching the NEXT command 2 is added to I and the BASIC returns to the command following the FOR command. This is repeated until I becomes greater than 10 where upon execution continues with the command following the NEXT command.

Hence, the machine will print

```
2
```

```
4
```

```
6
```

```
8
```

```
10
```

On exit from the loop I remains at its next value ie 12. If statement 10 had been

```
10 FOR I=2 TO 11 STEP 2
```

I will be left at its first value greater than 11 ie 12.

Negative indexing is allowed as long as the first value is greater than or equal to the second and the step is negative.

```
10 FOR I=10 TO 1 STEP -1
```

```
50 NEXT I
```

I will start at 10 and step down to 1 in increments of 1.

If STEP is omitted, a step of 1 is assumed.

```
10 FOR I=1 TO 100
```

I will start at 1 and step up to 100 in increments of 1.

Once more, expressions can be used in all three positions instead of numbers. The expressions are evaluated when the FOR command is executed and any following changes to the variables used will not effect the loop.

```
10 LET I=10
```

```
20 FOR I=I TO I+5
```

```
50 NEXT I
```

The initial value of I is evaluated as 10, the final value is 15. Within the loop, I will index from 10 to 15 in steps of 1

FOR and NEXT commands can be 'nested' within each other, the limit being that of the size of the stack.

```
10 FOR I=1 TO 10
```

```
20 FOR J=1 TO 5
```

```
30 PRINT I*J
```

```
40 NEXT J
```

```
50 NEXT I
```

This will result in the machine printing I*J when

```
I=1 and J=1 2 3 4 5 then
```

```
for I=2 and J=1 to 5
```

```
etc. etc.
```

```
until I=10
```

When a NEXT command is executed, the BASIC interpreter checks that the variable specified is the same as that used by the most recent FOR. If they are not the same, the FOR is terminated and the previous FOR examined. This continues until a match is found.

```
10 FOR I=1 TO 10
```

```
20 FOR J=1 TO 10
```

```
30 IF J=5 GOTO 50
```

```
40 NEXZ J
```

```
50 NEXT I
```

Each time J gets to 5, the BASIC jumps to statement

50. This cancels the J FOR loop leaving J at 5 and continues with the I for loop.

If within a FOR loop, another FOR loop using the same variable is encountered, the first FOR loop is terminated.

Stop

The stop commands stops the execution of the programme when it is executed. Any number of STOP commands can be included within a programme.

- 10 GOSUB 100
- 20 GOSUB 200
- 30 GOSUB 300
- 40 STOP

VDU

The VDU command allows the programmer direct access to the VDU control chip and its memory hence allowing a wide range of graphics applications.

The VDU command has two parameters, the first being the VDU memory address, the second being the desired graphic symbol specified as a decimal number.

10 VDU 5, 126

This will result in the graphic —> being placed in the fifth byte of the VDU memory.

The VDU memory is arranged as 16 rows each containing 64 bytes therefore addresses 1 to 64 are on the first row, 65 to 128 on the second etc.

Due to the function of the VDU control chip, care should be taken when using the first row and the first column as certain graphics characters will produce strange effects.

To allow the programmer to use all the VDU control commands, address zero has been allocated.

10 VDU 0, 12

This does not use memory location zero, instead the value 12 is output to the VDU controller.

12 is the command to clear the screen and reset the cursor.

Note that commands 12 and 28 require an extra delay while the command is executed. A FOR loop should be used (FOR I=1 TO 150; NEXT I before the next PRINT, VDU or INPUT command.

Other useful VDU commands are as follows:

- 8 Backspace cursor one character
- 9 Forward space cursor one character
- 10 Line Feed (Move cursor down on line)
- 11 Move cursor up one line
- 12 Reset cursor to top and clear screen
- 13 Carriage Return — Reset cursor to start of line clearing rest of line
- 27 Line Feed
- 28 Reset cursor to top without screen clear
- 29 Reset cursor to start of line without rest of line clear.

When using the memory mapping option, care must be taken to make sure that the memory address is between 1 and 1024 inclusive. If you exceed 1024 it is possible to overwrite the stack and your programme.

It is possible to make your BASIC programme modify itself using VDU but this is fairly difficult and

not really worth the trouble it can cause.

Before using memory mapping it is advisable to use either command 12 or 28 to reset the cursor. If the screen has been scrolling, row 1 will not be at the top of the scan unless this is done.

The graphic symbol specified in the second parameter is a decimal number between 0 and 255 inclusive. If a larger number is specified, only the least significant byte is used.

The graphics and character code are given elsewhere in ETI but some of the more useful are listed below.

0 to 31	see Graphic Font
32 Space	
33 — 47	! " # \$ % & ' () * + , - . /
48 — 57	0 to 9
58 — 64	: ; < = > ? @
65 — 90	A to Z
91 — 95	[]
96 — 127	see Graphics Font
128 — 225	Is a repeat of 0 to 127 (The high order bit is ignored)

To print a variable between 0 and 9 using VDU just add 48.

VDU 0, I + 48

This will print the value of I if it lies between 0 and 9.

To produce moving graphics, it is necessary to use FOR loops to index the memory mapping.

Direct commands

The following are direct commands to the BASIC Interpreter. They are obeyed as soon as they are entered.

RUN will start the execution of the programme at the lowest statement number.

LIST will print out all statement in ascending numerical order.

LIST 100 will print out all the statements starting at statement 100.

LIST 50, 10 will print 10 lines starting at statement 10.

NEW will delete all programme statements ready for a new programme.

Control C will return you (at any time) to the Monitor.

Any BASIC command can be entered as a Direct Command by leaving off the statement number. The statement is then executed immediately and not stored as part of the programme.

This feature is very useful when your programme stops due to an error report. (see Error Reports)

Abbreviations

All the commands can be abbreviated as follows.

It is advisable only to abbreviate when you are tight on memory as the abbreviated programme can be extremely difficult to follow.

Functions

- A. = ABS
- R. = RND
- S. = SIZE

Commands

- Implied = LET ie A=B+C, D=E+F etc



BASIC

REM.	=	REMARK
P.	=	PRINT
IN.	=	INPUT
I.	=	IF
G.	=	GOTO
GOS.	=	GOSUB
R.	=	RETURN
F.	=	FOR
TO.	=	TO
S	=	STEP
N.	=	NEXT
S.	=	STOP
V.	=	VDU
Direct Commands		
L.	=	LIST
R.	=	RUN
N.	=	NEW

Error Reports

It is quite probable that you can have already seen some of the error reports generated by the BASIC Interpreter.

Although there are only three different error messages (WHAT? HOW? and SORRY) the BASIC will insert a question mark at the point where the error occurred.

WHAT? This means the interpreter has come across a command or expression that it can't interpret.

WHAT?

300 I? PUT A — INPUT is spelt wrongly.

WHAT?

40 A = 300/(B+C? — The close parenthesis is missing

HOW? This means the interpreter can not execute the command.

HOW?

60 A = 300*500? — The result is greater than 32767

10 A = 5, B = 0

20 C = A/B?

HOW? — You can't divide by zero

40 GOTO 37?

HOW? — Statement 37 is missing

SORRY

This means that there is not enough memory. This can occur during typing in a programme or during the execution when the array is used — @(). It is worth checking the variable or expression if the array is involved to make sure that it is a sensible value.

210 A = @(I*J + K)

SORRY

If this occurred during typing in of the programme then there is not enough memory.

If this occurred during execution (RUN) then either there is not enough memory for @ or the expression I*J + K may be incorrect.

To check this type

PRINT I,J,K,I*J+K

and the values of I J K and I*J + K will be printed. You can now check if the result is correct.

This shows how useful the direct command option is. If the result of the PRINT is OK then another check is

PRINT SIZE

This will give how much memory space (in bytes) is left.

CTI



NASCOM I MICRO-COMPUTER for the HOBBYIST

As reviewed in this issue

THE ONLY COMPLETE MICRO-COMPUTER AVAILABLE TO THE HOME CONSTRUCTOR

FEATURES

- ★ Supplied in kit form for self-assembly
- ★ Full documentation supplied
- ★ Fully screened double-sided plated through hole printed circuit board
- ★ Full 48 key keyboard included
- ★ 2K x 8 Ram
- ★ 1K x 8 monitor program in Eprom
- ★ Powerful Mostek Z80 CPU
- ★ 16 x 48 character display interface to std un-modified T.V.
- ★ T.V. display memory mapped for high speed access
- ★ On board expansion to 2K x 8 Eprom
- ★ On board expansion for additional 16 I/O lines
- ★ Memory may be expanded to full 60K (plus 4K existing on board)

SOFTWARE FEATURES

- ★ 1K x 8 monitor program providing
- ★ 8 operating commands supporting Mem examine/modify, tabulate, copy, break, single step execute tape, load, tape dump.
- ★ Reflective monitor addressing for flexible monitor expansion through user programs
- ★ Monitor sub-routines include — delay ASCII coding, binary to hex conversion, chr screen, scroll up, string print, cursor shift and many others.

EXPANSION

- ★ Expansion buffer board £25.00
- ★ Memory board, with decoders and all hardware except memory ICS £35.00
- ★ 4K dynamic memory ICS £36.00
- ★ 8K dynamic memory ICS £60.00
- ★ 16K dynamic memory ICS £144.00
- ★ 32K dynamic memory ICS £250.00
- ★ I/O board with decoders and all hardware except ICS will accept up to 3 PIOs, 1 CTC and 1 UART £35.00

NEW "B-BUG" extended monitor in 2K of EPROM. Fully software compatible with NASBUG, supporting additional features — Full keyboard shift for all 128 characters, full cursor movement routines, Read and Write commands (fast tape load and dump), H and N commands (for inserting ASCII code directly into programme), Arith. command (for calculating relative jumps), Generate command (for automatic programme start), Intelligent copy (for non-destructive re-location of DATA), Random, block handling, ASCII to BCD and BCD to ASCII routines and many more, 2 EPROMS + full documentation — £24.50.

- ★ S.a.e. for full expansion details.

OTHER HARDWARE

- ★ 2.2A power supply for up to 4K expansion £19.90
- ★ 8A power supply for larger than 4K expansion £45.00
- ★ Expansion card frame £29.50
- ★ Programming manual £3.50
- ★ Hardware & software manuals (supplied in kit) £2.95

Trade, Government and Educational Enquiries Invited

Add VAT at 8% on all items except manuals

Demonstrations Continuous at our Store

Construction
Manuals
Separately
£2.95

Complete Kits
NOW IN STOCK

£197.50
+VAT 8%
POST PAID

Sole Appointed
London
Stockists

After sales service available

HENRY'S RADIO All mail to: Henry's Radio 404 Edgware Rd, London W2
LONDON W2 404 6 Edgware Road Tel: 01-723 1008

ADVANCED COMPUTER PRODUCTS

THE FIRST TO OFFER PRIME PRODUCTS TO THE HOBBYIST AT FAIR PRICES NOW LOWERS PRICES EVEN FURTHER!

1. Proven Quality Factory tested products only, no re-tests or fallouts. Guaranteed money back. We stand behind our products.

2. Same Day Shipment All prepaid orders with cashiers check, money order or charge card will be shipped same day as received.

\$100 PRODUCTS

LOGOS 1 8K STATIC RAM

- ★ Low Power
- ★ Selectable Memory Protect
- ★ Totally Buffered
- ★ Battery Back-up
- ★ Address on 1K boundary
- ★ Requires no front panel
- ★ No wait states



Z-80/Z-80A CPU BOARD

- ★ On board 2708
- ★ Power on jump
- ★ 2708 included (450ns)
- ★ completely socketed

Assembled and tested	\$185.00
Kit	\$129.95
Bare PC Board	\$ 34.95

★ For 4MHz Speed Add \$15.00

ASSEMBLED & TESTED

250ns	\$99.95
450ns	\$179.95

KIT

250ns	\$149.95
450ns	\$259.95

MICRODESIGN MR-16 2716 EPROM BOARD (MR-8 Also Available at same price)

- ★ Individual Prom Address
- ★ Uses Low cost 16K 1T EPROMS
- ★ Optional 1K RAM
- ★ Phantom control

Assembled and Tested	174.95
Kit	99.50

SPECIAL SPECIAL SPECIAL

2708-8 Eprom	8 @ \$ 5.50 ea
416 16K RAM	32 @ \$16.95 ea
1771-01 Floppy	5 @ \$25.95 ea
Pet Connector Set	5 @ \$ 7.95 ea

IMS 16K STATIC RAM

- ★ Memory mapping
- ★ Phantom
- ★ Address 16K Bound
- ★ Use with or w/o front panel
- ★ Power 2 1 amps typ
- ★ Uses 2114

ASSEMBLED & TESTED ONLY

450ns	\$439.95
250ns	\$495.95

BYTE USER 8K EPROM BOARD

- ★ Power on Jump
- ★ Reset Jump

Assembled & Tested	94.95
Kit	64.95
Bare PC Board	21.95

Special Offer: Buy 4 kits only \$59.95 each
NOTE: 2708-6 only \$5.95

S-100 32K STATIC RAM

- ★ Address 32K Boundary
- ★ Power 450ns, 2.8 amps typ
- ★ No wait states on 2MHz
- ★ Fully Buffered
- ★ Phantom can be added
- ★ 2114/TMS4045 or 9135

ASSEMBLED & TESTED

250ns	\$730.00
450ns	\$849.00

KIT

250ns	\$625.00
450ns	\$769.95

Bare PC Board w/Data \$59.95
Kit without Memory only \$99.95
Add 2114 Memory for 8 @ \$7 50 ea

TARBELL FLOPPY INTERFACE

- ★ S100 Compatible
- ★ Uses CPM
- ★ Jumper Selectable
- ★ Perci, Snugart, etc

Assembled and tested	\$269.95
Kit	\$179.95
Bare PC Board	\$ 39.95

NOTE: For CPM Add \$70.00
Documentation Add \$20.00

PARATRONICS LOGIC ANALYZER KIT

MODEL 100A	\$219.95
------------	----------

(analyzes any type of digital system)

Trigger Expander Model 10... \$229.00

Baseplate 9.95
Model 10 Manual 4.95
Model 150 Bus Grabber Kit 369.00

TRS 80 UPGRADE KIT

16K Memory with Jumpers and Instructions \$159.95
(Specify Level I or Level II)

APPLE II 16K UPGRADE KIT \$149.95

DC HAYES DATA COMMUNICATIONS ADAPTER

- ★ Telephone/TWX
- ★ S-100 compatible
- ★ Bell 103 freq
- ★ Originate & answer mode

Assembled & Tested	\$279.95
Bare PC Board w/data	\$ 49.95

PET to S-100 ADAPTER

Allows Pet to be interfaced to popular S-100 Bus

Kit	\$189.95
Assembled	\$269.95

For Low Cost 8 Slot Bus to expand your Pet only \$149.95 Kit

DATABASES & MANUALS

1-800-Data	\$ 3.95	IBM 4045-BI Data	3.95
ASCII-User Guide	4.95	IBM 4045-BI Data	4.95
ASCII-User Guide (2nd ed.)	4.95	IBM 4045-BI Data	4.95
ASCII-User Guide (3rd ed.)	4.95	IBM 4045-BI Data	4.95
ASCII-User Guide (4th ed.)	4.95	IBM 4045-BI Data	4.95
ASCII-User Guide (5th ed.)	4.95	IBM 4045-BI Data	4.95
ASCII-User Guide (6th ed.)	4.95	IBM 4045-BI Data	4.95
ASCII-User Guide (7th ed.)	4.95	IBM 4045-BI Data	4.95
ASCII-User Guide (8th ed.)	4.95	IBM 4045-BI Data	4.95
ASCII-User Guide (9th ed.)	4.95	IBM 4045-BI Data	4.95
ASCII-User Guide (10th ed.)	4.95	IBM 4045-BI Data	4.95

DISKETTES

- 5 MINI
- 5 5/8" Soft Sector
- 10 Sector
- 16 Sector

\$4.00 each \$39.00/10

NORTH STAR MINI

\$4.95 each \$45.00/10

8 STANDARD

- Hard
- Soft

\$4.95 each \$41.00/10

6800 DESIGNER BOARDS

- ★ Motorola Compatible Modules
- ★ MEK 6800 D2 Kit \$235.00
- ★ 3600 6800 MPU Module 495.00
- ★ 6801 16 slot Mother Bd 175.00
- ★ 6802 16 slot Card Cage 75.00
- ★ 6803 8 slot Mother Bd 99.00
- ★ 6804 System Power Supply 250.00
- ★ 6805 Prototype Board 36.00
- ★ 6806 4K EPROM Module 250.00
- ★ 6807 16 port parallel I/O 375.00
- ★ 6808 8K Static RAM 295.00
- ★ 6809 16K Static RAM Kit 225.00
- ★ 6810 Extender Card 60.00
- ★ 6811 Multiple Tuner Prog 395.00
- ★ 6812 8 port Duplex Async I/O 395.00
- ★ 6813 43/95 Connectors w/Photos 5.95
- ★ AMV EVK 99 6800 sub Kit 99.00
- ★ AMV EVK 200 Kit 249.95
- ★ AMV EVK 300 Assembled 275.00

EVK Kluge Board 95.00

EVK 16K Byte Ram Board 75.00

EVK 6 Slot Motherboard 35.00

EVK Extender Board 45.00

EVK Solid Frame Chassis 129.00

EVK Connectors 6.50

AMI 6800 Prolo Rom 30.00

AMI 6800 Micro Assembler Rom 30.00

6800 Tiny Basic Paper Tape 20.00

6800 Tiny Basic Eprom 125.00

Hi PLOT LOW COST DIGITAL PLOTTER

- ★ RS-232
- ★ Plot Size 7 1/8" x 10"
- ★ Digitizer Avail. Soon
- ★ High Resolution
- ★ 2.4/sec Plot Speed

NEW LIST \$1085.00

OUR PRICE \$999.00

SPECIAL KEYBOARD BUY WHILE THEY LAST

"Clare Pender 62 Key ASCII w/26 Pin & 34 Pin Output Conn" \$54.95

SUPPORT DEVICES

3801 2.00	7500 14.95
3802 2.00	7501 14.95
3803 2.00	7502 14.95
3804 2.00	7503 14.95
3805 2.00	7504 14.95
3806 2.00	7505 14.95
3807 2.00	7506 14.95
3808 2.00	7507 14.95
3809 2.00	7508 14.95
3810 2.00	7509 14.95
3811 2.00	7510 14.95
3812 2.00	7511 14.95
3813 2.00	7512 14.95
3814 2.00	7513 14.95
3815 2.00	7514 14.95
3816 2.00	7515 14.95
3817 2.00	7516 14.95
3818 2.00	7517 14.95
3819 2.00	7518 14.95
3820 2.00	7519 14.95
3821 2.00	7520 14.95
3822 2.00	7521 14.95
3823 2.00	7522 14.95
3824 2.00	7523 14.95
3825 2.00	7524 14.95
3826 2.00	7525 14.95
3827 2.00	7526 14.95
3828 2.00	7527 14.95
3829 2.00	7528 14.95
3830 2.00	7529 14.95
3831 2.00	7530 14.95
3832 2.00	7531 14.95
3833 2.00	7532 14.95
3834 2.00	7533 14.95
3835 2.00	7534 14.95
3836 2.00	7535 14.95
3837 2.00	7536 14.95
3838 2.00	7537 14.95
3839 2.00	7538 14.95
3840 2.00	7539 14.95
3841 2.00	7540 14.95
3842 2.00	7541 14.95
3843 2.00	7542 14.95
3844 2.00	7543 14.95
3845 2.00	7544 14.95
3846 2.00	7545 14.95
3847 2.00	7546 14.95
3848 2.00	7547 14.95
3849 2.00	7548 14.95
3850 2.00	7549 14.95
3851 2.00	7550 14.95
3852 2.00	7551 14.95
3853 2.00	7552 14.95
3854 2.00	7553 14.95
3855 2.00	7554 14.95
3856 2.00	7555 14.95
3857 2.00	7556 14.95
3858 2.00	7557 14.95
3859 2.00	7558 14.95
3860 2.00	7559 14.95
3861 2.00	7560 14.95
3862 2.00	7561 14.95
3863 2.00	7562 14.95
3864 2.00	7563 14.95
3865 2.00	7564 14.95
3866 2.00	7565 14.95
3867 2.00	7566 14.95
3868 2.00	7567 14.95
3869 2.00	7568 14.95
3870 2.00	7569 14.95
3871 2.00	7570 14.95
3872 2.00	7571 14.95
3873 2.00	7572 14.95
3874 2.00	7573 14.95
3875 2.00	7574 14.95
3876 2.00	7575 14.95
3877 2.00	7576 14.95
3878 2.00	7577 14.95
3879 2.00	7578 14.95
3880 2.00	7579 14.95
3881 2.00	7580 14.95
3882 2.00	7581 14.95
3883 2.00	7582 14.95
3884 2.00	7583 14.95
3885 2.00	7584 14.95
3886 2.00	7585 14.95
3887 2.00	7586 14.95
3888 2.00	7587 14.95
3889 2.00	7588 14.95
3890 2.00	7589 14.95
3891 2.00	7590 14.95
3892 2.00	7591 14.95
3893 2.00	7592 14.95
3894 2.00	7593 14.95
3895 2.00	7594 14.95
3896 2.00	7595 14.95
3897 2.00	7596 14.95
3898 2.00	7597 14.95
3899 2.00	7598 14.95
3900 2.00	7599 14.95
3901 2.00	7600 14.95
3902 2.00	7601 14.95
3903 2.00	7602 14.95
3904 2.00	7603 14.95
3905 2.00	7604 14.95
3906 2.00	7605 14.95
3907 2.00	7606 14.95
3908 2.00	7607 14.95
3909 2.00	7608 14.95
3910 2.00	7609 14.95
3911 2.00	7610 14.95
3912 2.00	7611 14.95
3913 2.00	7612 14.95
3914 2.00	7613 14.95
3915 2.00	7614 14.95
3916 2.00	7615 14.95
3917 2.00	7616 14.95
3918 2.00	7617 14.95
3919 2.00	7618 14.95
3920 2.00	7619 14.95
3921 2.00	7620 14.95
3922 2.00	7621 14.95
3923 2.00	7622 14.95
3924 2.00	7623 14.95
3925 2.00	7624 14.95
3926 2.00	7625 14.95
3927 2.00	7626 14.95
3928 2.00	7627 14.95
3929 2.00	7628 14.95
3930 2.00	7629 14.95
3931 2.00	7630 14.95
3932 2.00	7631 14.95
3933 2.00	7632 14.95
3934 2.00	7633 14.95
3935 2.00	7634 14.95
3936 2.00	7635 14.95
3937 2.00	7636 14.95
3938 2.00	7637 14.95
3939 2.00	7638 14.95
3940 2.00	7639 14.95
3941 2.00	7640 14.95
3942 2.00	7641 14.95
3943 2.00	7642 14.95
3944 2.00	7643 14.95
3945 2.00	7644 14.95
3946 2.00	7645 14.95
3947 2.00	7646 14.95
3948 2.00	7647 14.95
3949 2.00	7648 14.95
3950 2.00	7649 14.95
3951 2.00	7650 14.95
3952 2.00	7651 14.95
3953 2.00	7652 14.95
3954 2.00	7653 14.95
3955 2.00	7654 14.95
3956 2.00	7655 14.95
3957 2.00	7656 14.95
3958 2.00	7657 14.95
3959 2.00	7658 14.95
3960 2.00	7659 14.95
3961 2.00	7660 14.95
3962 2.00	7661 14.95
3963 2.00	7662 14.95
3964 2.00	7663 14.95
3965 2.00	7664 14.95
3966 2.00	7665 14.95
3967 2.00	7666 14.95
3968 2.00	7667 14.95
3969 2.00	7668 14.95
3970 2.00	7669 14.95
3971 2.00	7670 14.95
3972 2.00	7671 14.95
3973 2.00	7672 14.95
3974 2.00	7673 14.95
3975 2.00	7674 14.95
3976 2.00	7675 14.95
3977 2.00	7676 14.95
3978 2.00	7677 14.95
3979 2.00	7678 14.95
3980 2.00	7679 14.95
3981 2.00	7680 14.95
3982 2.00	7681 14.95
3983 2.00	7682 14.95
3984 2.00	7683 14.95
3985 2.00	7684 14.95
3986 2.00	7685 14.95
3987 2.00	7686 14.95
3988 2.00	7687 14.95
3989 2.00	7688 14.95
3990 2.00	7689 14.95
3991 2.00	7690 14.95
3992 2.00	7691 14.95
3993 2.00	7692 14.95
3994 2.00	7693 14.95
3995 2.00	7694 14.95
3996 2.00	7695 14.95
3997 2.00	7696 14.95
3998 2.00	7697 14.95
3999 2.00	7698 14.95
4000 2.00	7699 14.95
4001 2.00	7700 14.95
4002 2.00	7701 14.95
4003 2.00	7702 14.95
4004 2.00	7703 14.95
4005 2.00	7704 14.95
4006 2.00	7705 14.95
4007 2.00	7706 14.95
4008 2.00	7707 14.95
4009 2.00	7708 14.95
4010 2.00	7709 14.95
4011 2.00	7710 14.95
4012 2.00	7711 14.95
4013 2.00	7712 14.95
4014 2.00	7713 14.95
4015 2.00	7714 14.95
4016 2.00	7715 14.95
4017 2.00	7716 14.95
4018 2.00	7717 14.95
4019 2.00	7718 14.95
4020 2.00	7719 14.95
4021 2.00	7720 14.95
4022 2.00	7721 14.95
4023 2.00	7722 14.95
4024 2.00	7723 14.95
4025 2.00	7724 14.95
4026 2.00	7725 14.95
4027 2.00	7726 14

microfile

Gary Evans has found himself a new home this month and reports on a way to save money and the latest in train controllers amongst other things.

OVER THE PAST FEW months the advertising pages of ETI have seen the inclusion of a number of American firms offering a wide range of components aimed in the main at the DIY computer hobbyist. The prices of many of the goods available, when converted into pounds, make very attractive reading. The snag — and there must be one — is just how do we go about getting the things over from the States.

The procedure is not as harrowing as one might suspect. The first thing to do is to identify exactly what it is you want to buy and the exact cost in dollars of the goods plus packing. Go along to your bank with the advert and tell them exactly what you want to buy and the cost in dollars. They will prepare a dollar draft, a document which, in conjunction with a sister bank in the States, will be as good as cash to the firm supplying the components. Note that your bank account will be debited at this stage.

Now its just a matter of sending off the draft plus your order — the things should arrive in the post within the next few days.

If the firm in the States 'does a bunk' with your hard-earned greenbacks, however, getting anything back will prove very difficult if not impossible. We would let you know of any companies that we know are not honouring their orders but it would be best to place a small order to try out a firm's credibility before parting with a large amount of money.

I might mention that an advert in last month's ETI, not even I've seen this month's ad pages, from an American firm, is advertising a TR5-80 16K conversion kit with information about which jumpers to change for a good bit under £100. When you compare this to the £200 plus Tandy want in addition to the fact that with the DIY way you keep your original 4K, you can see that shopping in the States can be very profitable.

Club Together

I've had a few, not a lot, but a few replies to my 'Club Call' a couple of months ago.

In the Midlands, a group of the ACC has been having successful bi-monthly meetings for about a year — contact John Diamond at 27 Loweswater Road, Binley, Coventry. Also in the midlands is the West Midlands Computer Club which has just held its first meeting in Brierly Hill. Contact Tony Bridgewood on 021-557 6709.

Now a plea for those interested in starting a branch of the ACC in Bristol, those interested contact Rex Godby at 16 Williamson Road, Ashley Down, Bristol.

Finally the Cambridge University Processor Group (they've got very nice notepaper) which despite the name is open to everyone and holds regular meetings during term time (that's about four months out of twelve from what I hear). Tim Hopkins is the man to contact at Magdaline College, Cambridge.

In all the above cases please enclose an SAE with any letter.

News of another firm generating games — initially for

— you guessed it PET — the firm plan to expand into Z80 machine code programs — NASCOM, MICROS, RM 380Z with possibly games for KIM-1.

Mini micro are at 47 Queens Road, London, N11 2QP. Their catalogue is available — again send an SAE.

Shocking Story

It was my pleasure to build up one of the Triton prototypes. Enough has been said about the machine elsewhere in this issue, I'll just add my congratulations to the designer Mike Hughes for producing a really excellent project.

Before leaving the subject you might be interested to hear of an experiment I performed with the machine. It was designed to test the Triton under extreme conditions, namely applying high voltage AC the selected components via a high resistance. Needless to say I was the high resistance and the fact that I'm telling the tale show I'm OK, the Triton hardly twitched which could not be said for me.

House Trained

Details are scarce, but the model train exhibition at the end of August saw the preview of an MPU controlled train system.

Designed by Hornby, who have designated it the Zero-1, the controller will enable up to 16 trains to be controlled on a layout, each being called up by a key pad. The trains will have programmable levels of inertia.

This is not a 'section' system, control being, presumably, by a pulse code system. The conversion of the train is simple, a small circuit block being inserted in the motor's power lines.

Due for launch late next year the Zero-1 should make Christmas '79 something to remember, as at a price of about £30/£40 it must be a must, to coin a phrase.

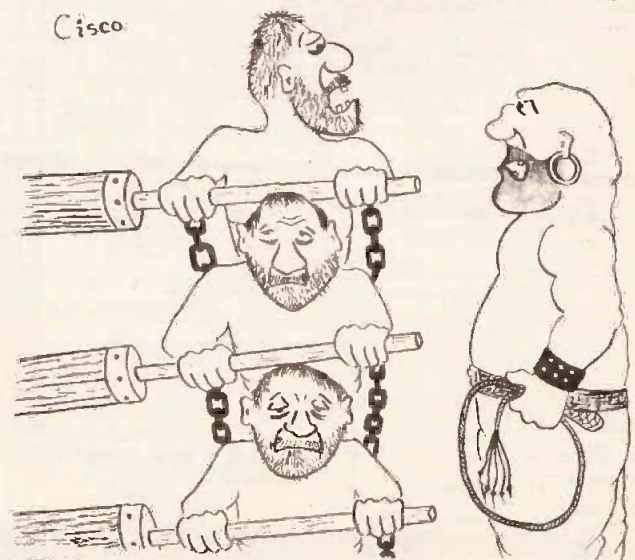

"Any truth in the rumour we're about to be replaced by an MPU boss."

COMPUTING TODAY — NOVEMBER 1978



MICRO-COMPUTER BARGAINS

We have a stock of untested micro-computer PCB's which are surplus to our requirement. Each board contains an Intel 4040 (CPU), 4201 (Clock), 4289 (Standard Memory Interface), 5MHz crystal, zero crossover detector cct, power on reset cct, skts for 6 x 1702A PROM and on board power supply containing transformer, rectifier, regulator, heatsink and reservoir capacitor. These PCB's are sold with data on all chips and cct diagram, as untested units at the bargain price of

£19.00 ea

Also available:

- 1702A memory, used but erased **£6.00**
- 1702A memory programmed to your requirement **£7.50**
- 6265 gen purpose i/p-o/p device **£5.00**

Cheque / Postal Order to:

VERDURE LTD.

54/64 Morfa Road
Strand, Swansea

Mail Order Supplies Only

Tel: (0729) 41241/462684

COMPUTING AD INDEX

Advanced Computer Products	p29
Airamco	p 3
Almarc	p8
Comp Computer Components	p32
Electronic Brokers	p8
Henrys	p28
Lotus Scund	p31
L.P. Enterprises	p20
Microdigital	p19
Micronics	p24
NASCO	p2
New Bear	p19
Science of Cambridge	p12, 13
Strathand	p4
Tangerine	p4
Technical Book Service	p25
Transam	p14
Verdure	p31
Viewfax	p4

MEMORIES

2112 (256 x 4 Static RAM)	£1.11
21L02 (450ns) (1K x 1 Static RAM)	£1.07
21L02 (250ns)	£1.60
2114 (1Kx4 Statis RAM)	£7.70
4027(300ns, equiv 2104)	£2.02
(4K x 1, 16 pin, Dynamic RAM)	
5208 (equiv 2107)	£3.21
(4K x 1, 22 pin, Dynamic RAM)	
4116	£13.00
(16K x 1, Dynamic RAM)	
2708	£7.87
(1K x 8 UVEPROM)	
8080A (CPU)	£7.45
81LS95 (Buffer TriS)	75p
81LS96 (Buffer TriS)	75p

All VAT inclusive
35p for p&p orders under £5

Please write for discounts
over 100 pieces

ALL FULL SPEC AND UNUSED

(Mail Order only)

PET CORNER

Lotus now carry an exciting range of products for your CBM PET

24K Memory Expansion

- ★ Mounts inside PET
- ★ Runs from PET's own power supply
- ★ Takes 10 minutes to fit
- ★ Includes memory test program
- ★ 6 month warranty

£399 inc. VAT & P&P

MUSIC BOX

Turns your PET into a programmable musical instrument. You can record and play up to 90 pages, 16 notes per page, change tempo, key etc

£37.50 inc. VAT & P&P

T.I.S. WORKBOOKS

A set of 5 workbooks to give you a full understanding of all the ins and outs of your PET more fully than any previous manuals.

£15.95 per set inc. P&P

Dustcover £17.95 inc. VAT & P&P

Lots of software and other goodies. Send large SAE.

LOTUS SOUND

4 MORGAN STREET
LONDON E3 5AB

INTERESTED IN HOME COMPUTING?



Start now and don't get left behind
THE NASCOM 1 is here
Ex-stock with full technical services

**BLANK C12
Racal Quality
CASSETTES
£4.90 for 10**

Plus the opportunity to join the fastest moving club of personal computer users enabling you to get the most out of your computer. You can OBTAIN and EXCHANGE programs and other software - many now available.

The Powerful Z80
Microprocessor
Professional Keyboard
1 Kbyte Monitor in EPROM
2 Kbyte RAM (expandable)
Audio Cassette interface
Plugs into your domestic TV

Easy construction from
straightforward instructions
- no drilling or special tools
- Just neat soldering
required.



Only **£197.50** + 8% VAT (includes p & p + insurance)

Manuals separately	3.50	Monitor quality improved	
Z80 programming Manual	6.90	TV Modulator	2.50
Z80 Technical Manual	3.40	Super Modulator (10MHz)	5.50
PIO Technical Manual	3.40	Power supply suitable for NASCOM	19.90

Available from COMP now. *4K and 16K RAM expansion boards for NASCOM 1 with sockets on board for MINIBASIC EPROMS. Trade, government and educational enquiries invited. Can be supplied ready built tested and guaranteed.

Introducing the personal computer you've waited for. THE EXIDY SORCERER.

SORCERER COMPUTER SYSTEM

AS SEEN ON OUR STAND
AT PCW SHOW

The Sorcerer Computer is a completely assembled and tested computer system. Standard configuration includes 63-key typewriter-style keyboard and 16-key numeric pad, Z80 processor, dual cassette I/O with remote computer control at 300 and 1200 baud data rates, RS232 serial I/O for communications, parallel port for direct Centronics printer attachment, 4K ROM operating system, 8K ROM Microsoft BASIC in Rom Pac™ cartridge, composite video of 64 char/line 30 line screen, 128 upper/lower case ASCII set and 128 user-defined graphic symbols, operation manual, BASIC programming manual and cassette/video cables, connection for S-100 bus expansion.



LOOK!

*32k RAM (16K available)
*RS232 interface * 8K BASIC ROM
*CUTS interface * 4K MONITOR
*KANSAS CITY interface * S100 BUS
* User defined graphic symbols * Z80 cpu

only **£950**
+ 8% VAT Credit facilities available.

VIDEO GAMES & Components

UHF Vision modulator Standard channel 36	2.90
UHF Vision modulator 10 MHz bandwidth high quality	5.90
VHF Vision modulator channel 3	3.10
Sound modulator compatible with above	2.90
AY-3-8500 6 Games	4.90 PCB 1.90
AY-3-8550 6 Games	3.90 PCB 1.90
AY-3-8610 10 Games	5.90 PCB 1.90
AY-3-8760 Motor-bike	6.90 PCB 1.90
AY-3-8710 Tank-battle	6.90 PCB 1.90
AY-3-8603 Road Race	5.90 PCB 1.90

* ETI Tank Battle kit - just add controls - **£14.90 reduced from £19.90.**

JOYSTICKS - £1.90 each Dual 200K lin

KEY BOARD

Brand new professional ASCII keyboards (USA)
Full technical details included.

Only **£49.90**
+ 8% VAT.

Ready built, tested and guaranteed.



NEW - AVAILABLE NOW

Shugart floppy drives **£290** each

Floppy drive controller direct from USA **£190** each



ETI 8080 ONE BOARD COMPUTER

ETI 8080
COMPONENTS IN STOCK

SEND SAE FOR
PRICE LIST OF
PARTS AND KIT.

COMPUTER COMPONENTS

A selection of our Computer components

CPU AND SUPPORT DEVICES

Z80	cpu	14.90
Z80A	cpu	20.50
Z80	PIO	9.90
Z80	CTC	9.90
8080A	cpu	7.95
8212	8 Bit I/O Port	3.50
8214	Priority Interrupt Control	9.00
8216	Bi-Directional Bus Driver	3.75
8224	Clock Generator & Driver (2MHz)	3.50
8224-4	Clock Generator & Driver (4MHz)	9.95
8226	Inverting Bi-Directional Bus Driver	3.95
8228	System Controller & Bus Driver	7.95
8238	System Controller & Bus Driver	7.50
8251	Programmable Communication Int.	18.95
8253	Programmable Interval Timer	12.00
8255	Programmable Peripheral Int.	17.95
8257	Prog. Direct Mem. Access Cont.	17.95
8259	Programmable Interrupt Cont.	11.90
6800	cpu	4.95
6810P	128 x 8 Static Ram (450ns)	6.00
6820P	Peripheral Interface Adaptor	7.50
6821P	Peripheral Interface Adaptor	7.50
6828P	Priority Interrupt Controller	11.25
6834P	512 x 8 Bit Erasable Prom.500	16.95
6850P	Asynchronous Comm. Adaptor	9.75
6825P	Synchronous Serial Data Adaptor	11.75
6860P	0-600 RPS Modem	14.50
6862P	2400 RPS Modem	28.00
6871P	Clock	8.75
6875P	Clock	2.50
6880P	MPU Bidir. Bus Ext.	

MEMORIES

2102	1K	1.20
21L02	1K	1.40
2101	1K	2.95
2111	1K	3.95
2112	1K	2.95
2114	4K	9.95
4116	16K	19.90
1702A	256B	5.00
2708	1K	10.90
2708	(NASBUG)	13.90
2716	(5V, INTEL)	29.00

OTHER

USEFUL DEVICES

6576	char gen	10.90
6402	UART	9.90
1771	Floppy disk controller	49.00

Full selection of US and British Magazines and books for the Computer Hobbyist.

Prices always changing (usually downwards)
Phone with your requirements

All prices include VAT except where shown. Orders over £5 post and packing free otherwise add 20p.



Please make cheques and postal orders payable to COMP, or phone your order quoting BARCLAYCARD or ACCESS number. For technical information and advice ring JIM WOOD, BSc(Eng), ACGI, MIEEE - Consultant to COMP.



COMP COMPUTER COMPONENTS

14 STATION ROAD · NEW BARNET · HERTFORDSHIRE · TEL: 01-441 2922
CLOSE TO NEW BARNET BR STATION - MOORGATE LINE 01-449 6596
OPEN - 10am to 7pm - Monday to Saturday

ETI MARKET PLACE

Digital Alarm

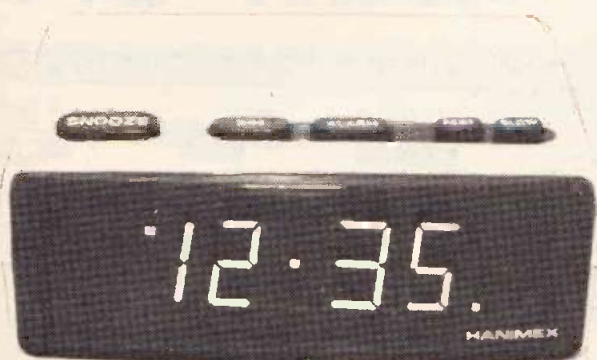

Size: 105mm wide 115mm deep x 55 mm high.

THIS IS THE THIRD digital alarm clock that we are offering (we regret the earlier versions are no longer available). We have sold thousands and thousands of these and our buying power enables us to offer a first rate branded product at a really excellent price.

The Hanimex HC-1100 is designed for mains operation only (240V/50Hz) with a 12 hour display, AM/PM and Alarm Set indicators incorporated in the large display. A switch on the top controls a Dim/Bright display function.

Setting up both the time and alarm is simplicity itself as buttons are provided for both fast and slow setting and there's no problem about knocking these accidentally as a 'locking' switch is provided under the clock. A 9-minute 'snooze' switch is located at the top.

£8.95

(Inclusive of VAT and Postage)

An example of this clock can be seen and examined in our reception at our Oxford Street offices.

LCD Watch



New low price!

The enormous numbers involved in ETI offers has enabled us to arrange a real bargain — a full spec LCD watch with adjustable metal bracelet for under half the going rate.

This watch gives continuous display of hours and minutes — press the button once and you'll get the date (American style). After a couple of seconds the display automatically reverts to time but if you press again you'll get a continuous seconds display.

Press another button and you get a back light, enabling you to see the display in the dark. Setting, or resetting is simplicity itself and a 'hold' facility allows you to set the watch spot on. The accuracy is magnificent, as with all the current range of digital watches and battery life is well in excess of a year.

£8.95

(Inclusive of VAT and Postage)

An example of this watch can be seen and examined in our reception at our Oxford Street offices.

DIGITAL ALARM

To:
Hanimex Alarm Offer
ETI Magazine
25-27 Oxford Street
London W1R 1RF

Please find enclosed my cheque/PO for £8.95 (payable to ETI Magazine) for a Hanimex Digital Alarm Clock.

Name

Address

Please allow 14 days for delivery

LCD WATCH

To:
LCD Watch Offer
ETI Magazine
25-27 Oxford Street
London W1R 1RF

Please find enclosed my cheque/PO for £8.95 (made payable to ETI Magazine) for my LCD Digital Watch.

Name

Address

Please allow 14 days for delivery

AUTOCHORD

PART ONE



WHILE NOT QUITE an instrument in its own right the auto chord is certainly more versatile than the common or garden rhythm generator.

The instrument is designed to be added to the lower two octaves of an organ and will provide a variety of accompaniment controlled by the mode selected.

The specification shows that the eight rhythms provided cover most requirements and gives some idea of the extra facilities offered by the auto chord.

The instrument will offer chords — major or minor third, fifth or diminished fifth and sixth of seventh. It will also provide a walking or alternate bass as well as arpeggios.

They say a picture is worth a thousand words, and at this moment we feel that at some time someone must have said much the same about sound. It's difficult to convey all the facilities offered by the auto chord on paper, so if you cannot visit Maplin's shop, where a unit will be on demonstration, you will just have to take our word that the auto chord provides everything that the solo musician could want.

The auto chord is designed to be incorporated within existing organs and is easiest to interface with a DC keyed organ although it is possible to use the auto chord with a direct keyed instrument.

Full constructional details plus a description of the auto chord in use will be presented next month.

SPECIFICATION

8 selectable rhythms

Covering waltz, rock to Latin. Latin American rhythms can be combined. Non-Latin American rhythms can be combined.

5 instruments

Bass. Snare drum. Low bongo. Claves. Cymbals.

CHORD ACCOMPANIMENT (with keyboard)

Three mode selection

1

1. AUTO

Playing one note produces a chord structured around this note, and will play continuously.

3

SEMI-AUTO

Individual notes or chords played are remembered and played continuously.

MANUAL

Notes or chords played only continue whilst the keys are held operated.

AUTO RESET

Variable bass. Delay-auto-stop and over-ride in all 3 modes. On/off. Walking or alternating in modes 2 and 3. A minimum of three notes. Must be played for bass accompaniment.

Auto: On/off.

Chord accompaniment: On/off.

Two octaves progressive in modes 2 and 3. Selectable maj/min 3rd/7th.

Variable tempo

Harmonic attack

Five tones added in short bursts

Arpeggio

Three selectable pitches

Chord accompaniment volume

Rhythm volume

FRONT PANEL CONTROLS

SW1	Mains on / off	SW18	Auto / semi-auto / manual
SW2	Auto on / off	SW19	Auto-stop / continuous
SW3 to 10	Rhythm select	SW20	Auto reset
SW11	Chord on / off	R13	Arpeggio. Off / 1 / 2 / 3
SW12	Harmonic attack	R26	Tempo
SW13	Major / minor 3rd	R131	Auto-stop time delay
SW14	7th	R140	Auto-accom. volume
SW16	Bass on / off		Rhythm volume
SW17	Bass — walking / alternating		

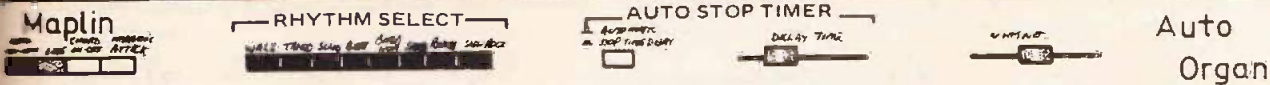

PARTS LIST

RESISTORS
1/2W

R126	47R
R24, 25, 155, 157, 159, 173, 181, 199, 216, 221, 234, 231	270R
R104	560R
R80	680R
R72, 88, 101, 115, 122, 143, 156	2k2
R55, 64, 71, 100	2k7
R154	3k9
R42, 56, 57, 58, 60, 162, 183, 238	4k7
R87	5k6
R116, 123, 125	6k8
R74, 75, 77, 117, 118, 124, 127, 131, 133, 135, 136, 140, 161, 182, 217, 222, 232, 235	10k
R15-20	12k
R76, 93	8k2
R28-49, 82, 95, 113, 158, 172, 208, 250	15k
R1-11, 14, 23, 73, 90, 168	22k
R106, 163, 170, 177, 191	27k
R54, 229	33k
R149-153	39k
R166, 167, 198, 203, 215, 239, 248	47k
R69, 70, 85, 86, 98, 99, 103	56k
R134, 230, 241	68k
R89, 102	82k
R62, 63, 66, 78, 79, 92, 120, 128, 132, 137, 160, 165, 169, 171, 174, 184, 186, 187, 200, 201, 204, 211, 212, 214, 219, 226, 227, 233, 236, 237, 240, 243, 245, 246, 249, 12, 21, 22, 27, 91	100k
R50-53, 67, 83, 96, 189, 195	150k
R185, 188, 242, 244	180k
R129, 138, 209, 210, 220	220k
R176, 192, 193, 197, 205, 206, 207, 225	270k
R81, 94, 179	330k
R65, 114, 121, 180, 223, 224	470k
R105	820k

R107, 112, 119, 175, 178, 218	1M0
R196, 213, 228	2M2
R108	4M7
1/4W	
R141	39R
R110	100R
R146, 147	180R
R144	330R
R142, 145	820R
R148	1k5
R194	43k

POTENTIOMETERS

R111	1k0
R61, 247	47k
R164, 190, 202	100k
R109	470k
R68, 84, 97	1M0

CAPACITORS

C68, 72, 79, 86, 93, 94, 95, 101, 103, 110	10n polyester
C100, 111, 85	22n polyester
C21, 22, 23, 107	33n polyester
C5, 11, 17, 25, 31, 35, 70, 99, 105, 108	47n polyester
C10, 40, 71	68n polyester
C1, 12, 20, 28, 30, 47, 69, 76, 104, 109	100n polyester
C75	150n polyester
C9	220n polyester
C13-16	27n polycarbonate
C24	47n polycarbonate
C6, 7, 8	82n polycarbonate
C2, 66, 97, 106	1u0 polycarbonate
C3	1n0 ceramic
C19, 27, 29, 33, 38, 43	10n ceramic
C4	22p ceramic
C78, 80	220n mylar
C49, 52, 55	100p polystyrene
C44, 74, 88, 96	330p polystyrene
C73, 89	470p polystyrene
C91, 92	680p polystyrene
C39, 90	1n0 polystyrene
C32	1n5 polystyrene
C45, 87	2n2 polystyrene
C18, 26, 36, 41, 67, 82, 83, 84	3n3 polystyrene
C102, 77, 81	4n7 polystyrene
C34	6n8 polystyrene
C98	1u5 63 V electrolytic

C48, 50, 51, 53, 54, 56, 59, 60, 64, 65	10u25 V electrolytic
C37, 42	22u 10 V electrolytic
C58, 63	100u 25 V electrolytic
C61, 62	220u 16 V electrolytic
C57	470u 25 V electrolytic
C46	1000uV 16 V electrolytic

SEMICONDUCTORS

IC1	M254
IC2-5	4011
IC6	M251
IC7	M087
IC8	4069
IC9-11	741
IC12	4016
IC13	4013
Q1-4, 7, 8, 10, 11, 12, 13, 15, 16	BC548
Q9, 14	BC177
Q5	BFY51
Q6	BFX87
D1-86, 94, 105	1N4148
D87-90	1N4002
D91	12 V 400mW
D92	5V6 400mW
D93	12 V 400mW
LED1	TIL209

SWITCHES

SW1	Mains latchswitch
SW2	2 pole latchswitch
SW3 to 10	8 2 pole latchswitch interdependent
SW11	2 pole latchswitch
SW12	2 pole latchswitch
SW13	2 pole latchswitch
SW14	2 pole latchswitch
SW16	2 pole latchswitch
SW17	2 pole c / over latch-switch
SW18	4p 3W rotary
SW19	2 pole latchswitch
SW20	Push (break) sw
SW21	3p 4W rotary

MISCELLANEOUS

PCBs, 15-0-15 250mA transformer, fuse plus holder, sockets, clip on heat sinks, cable, etc

Production problems have meant that the circuit diagrams for this project are without the usual component annotations.

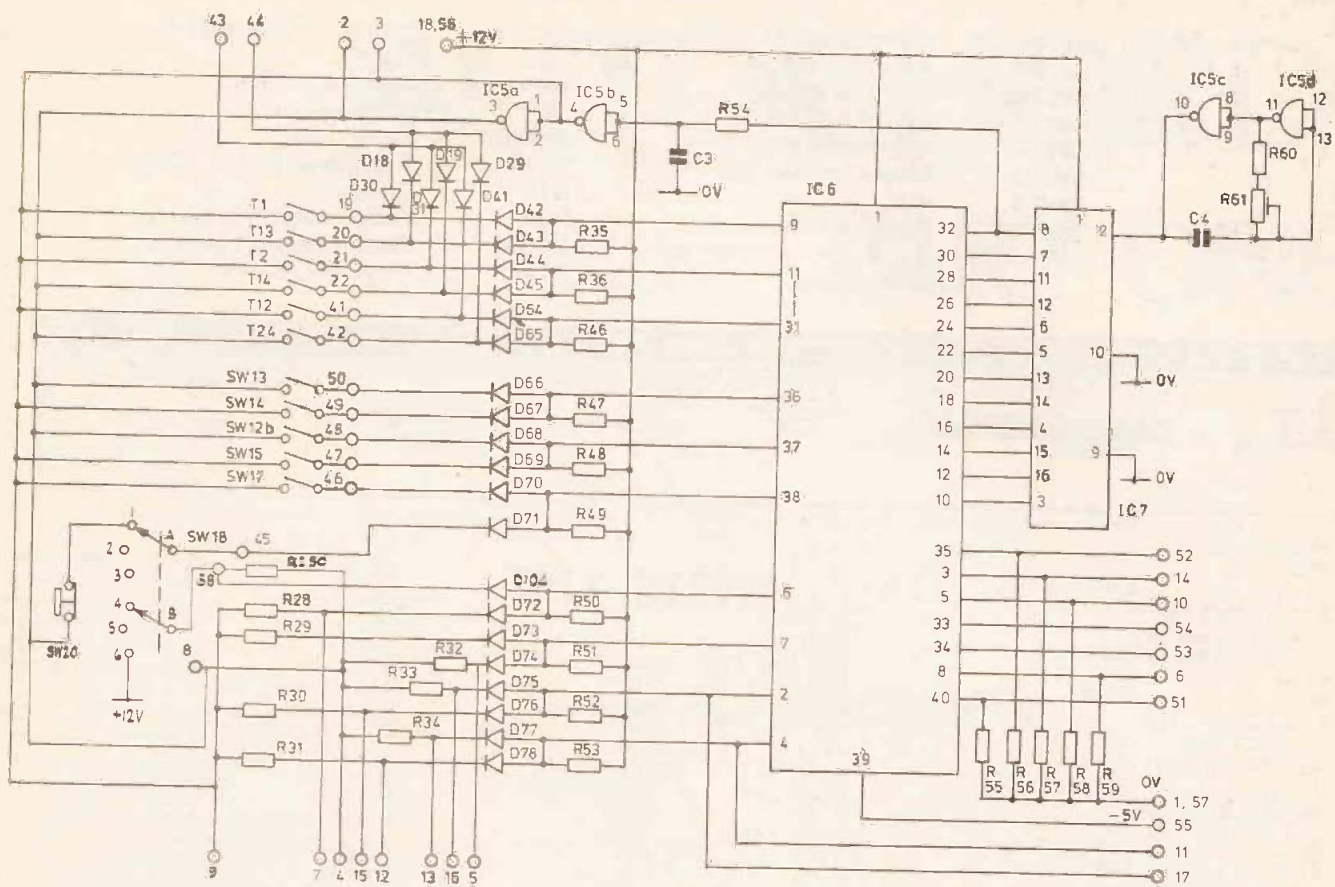

Circuit diagrams of the generator and coder

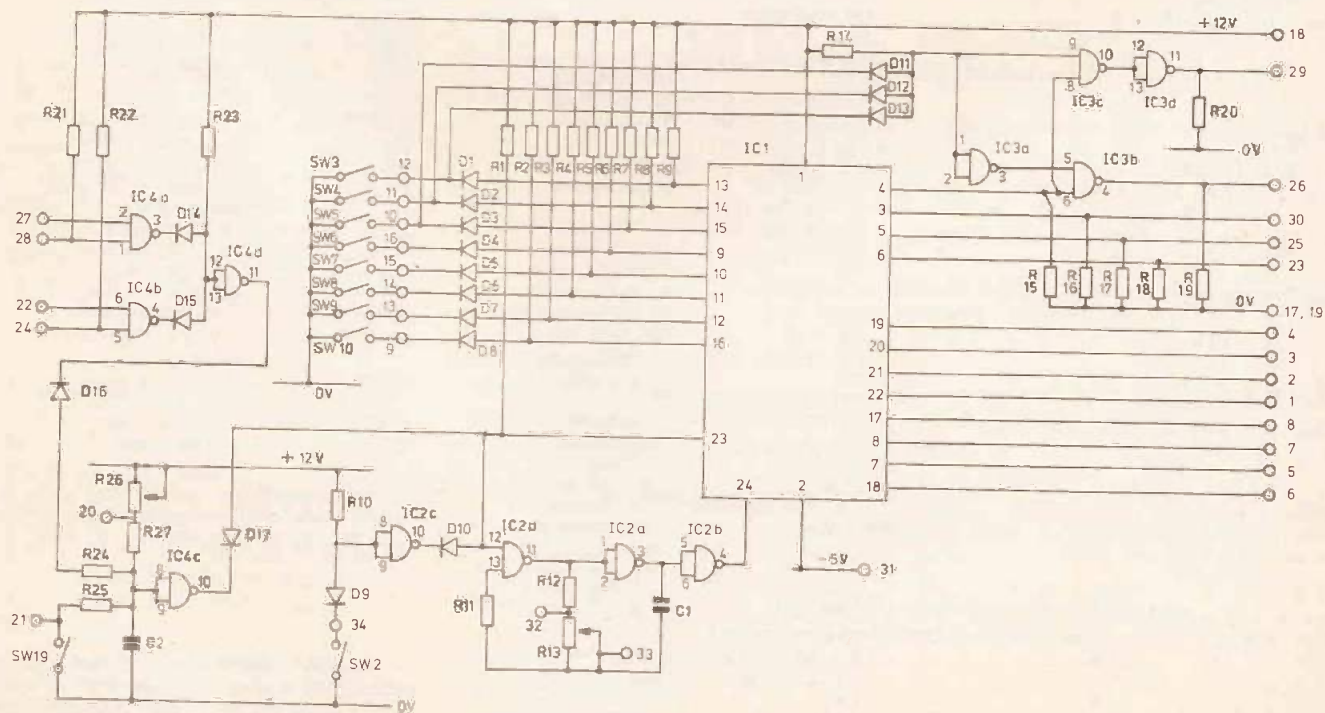

HOW IT WORKS

PRE AMPLIFIER

The chord and rhythm outputs are amplified and filtered in ICs 9 and 11 respectively. The outputs from these devices are fed, via level control potentiometers to the input of IC10. This mixes the two signals and provides the final output of the instrument at a level suitable for feeding to a power amplifier.

POWER SUPPLY

The various ICs used in the auto chord require supplies of +12 V, +11 V, -5 V and -11 V. The +12 V line is derived from the rectified AC output of T1 by the series pass element Q5. The voltage at the emitter of Q5 is determined by D91, a zener diode. The +11 V supply is a simple shunt from the 12 V line.

The -5 V line is again a series pass circuit, this time the output voltage being set by D92.

The -11 V rail is simply stabilised by zener diode D93 as the current demanded from this rail is not enough to warrant the use of another series pass transistor.

The LED supply is taken from the negative voltage rail and is current limited by R148.

GENERATOR AND CODER

The rhythm generator section of the instrument is centered on IC1. This is the M254, a device that contains a ROM that will drive the sound generators with a selection of eight rhythms. To select a desired rhythm, the appropriate input must be taken to ground, via SW3-10, will the other inputs are held high by resistors R1-R9.

The M254 requires a clock signal to operate and this is generated by the CMOS oscillator formed by IC2. The frequency of this oscillator, and ultimately, the tempo of the rhythm, is controlled by R13.

The arpeggio, chord and bass accompaniment are generated by IC6, the M251.

The IC is fed with 12 input frequencies from the tone generator, IC7. This is clocked by the output of the CMOS astable based on IC5c and d.

The M251 is used in conjunction with the M254 which is responsible for the selection of the various notes in the arpeggio/chord/bass accompaniment.

The M251 features a number of different modes of operation, in the automatic mode, when a number of keys in the two available octaves are played, the lowest note will be taken as a reference and memorised.

The memorized key, by means of an internal multiplexer, selects the corresponding tonic and all other notes programmed for arpeggio, chord and bass accompaniment.

In the semi-automatic mode, the M251 will memorise the lowest four keys played together with the top note played. The circuit will then provide accompaniment until the mode is cancelled by selecting automatic mode briefly and returning to semi-automatic while no keys are played.

The semi-automatic mode can also be selected without memorization of keys.

Due to the pin out restrictions of the 40 pin package a system of multiplexing has had to be adopted, this explains some of the complexity in this area of the circuit.

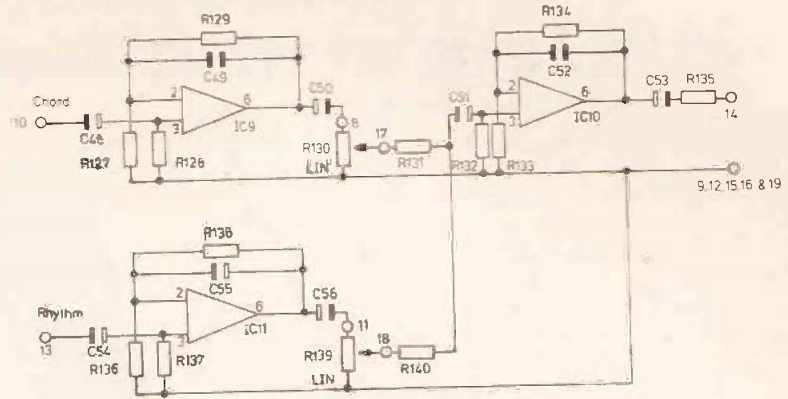

Circuit diagram of the preamplifier

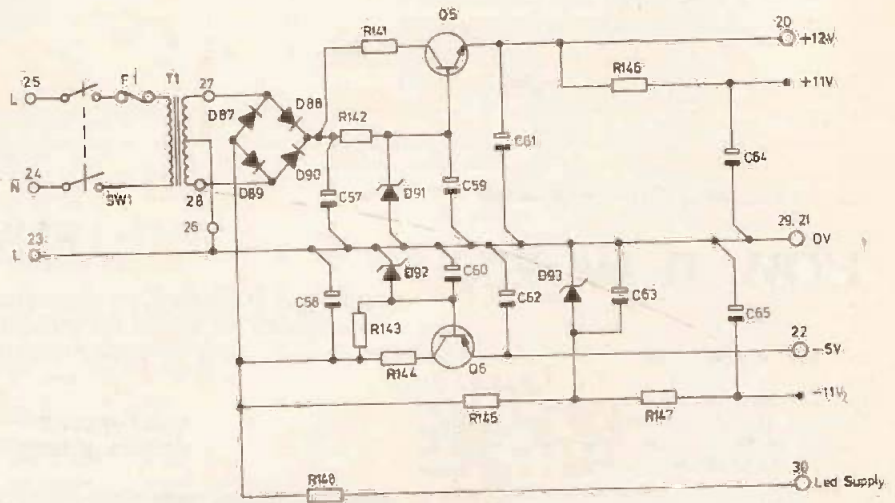

Circuit diagram of the power supply

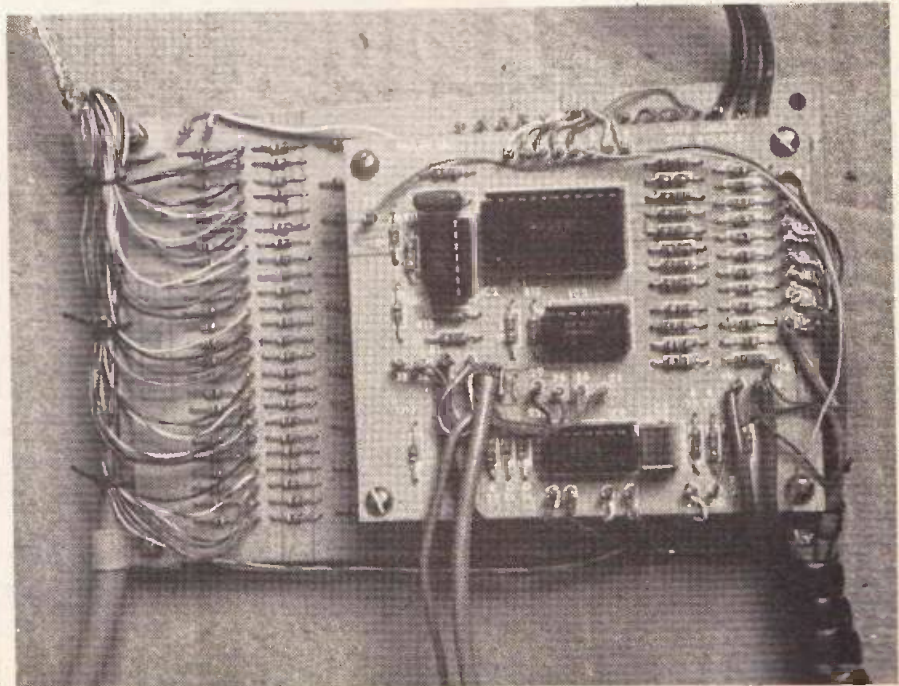

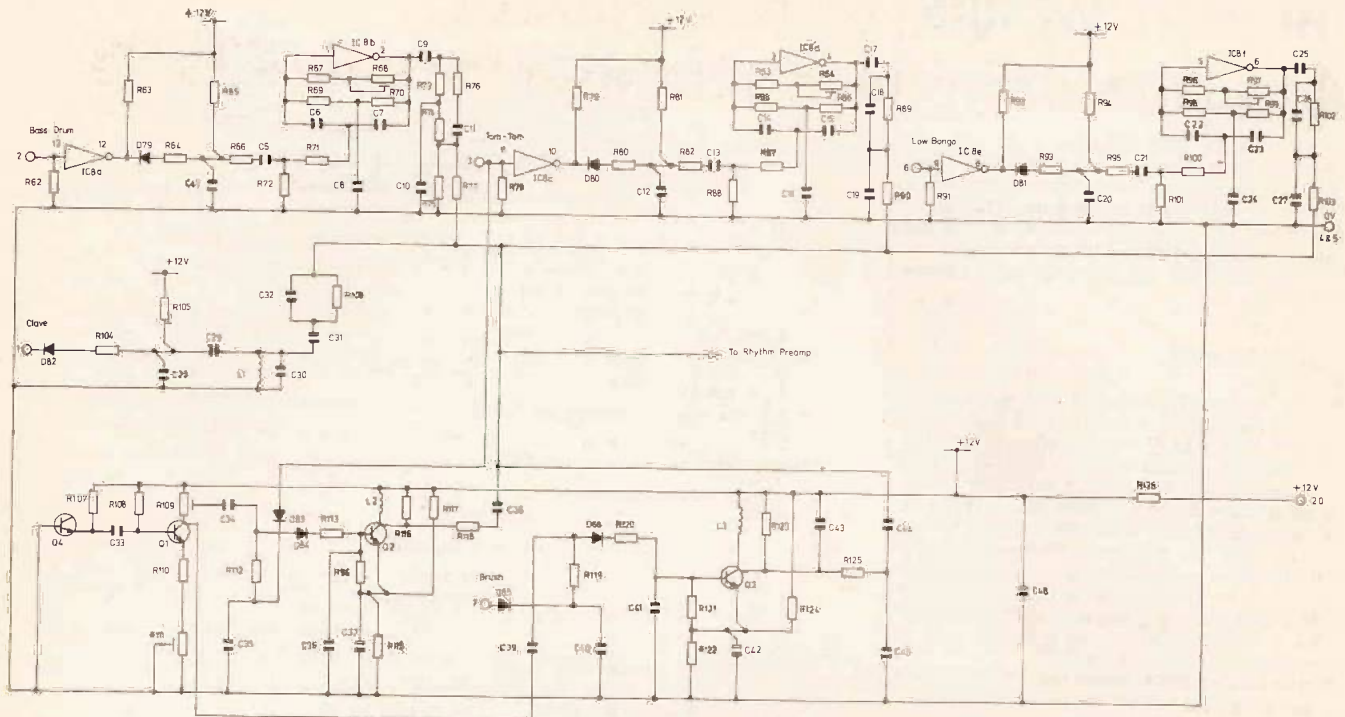

Circuit diagram of the voice generator

HOW IT WORKS

VOICE GENERATOR

THE bass drum, tom-tom and low bongo sounds are generated by the damped sinusoidal oscillators based upon the six inverters of IC8. Each of the oscillators are the same apart from the values of the timing capacitors which set the characteristic frequency of oscillation.

In each oscillator the variable resistor (R68, R84 and R97) will control the rate at which any oscillations will delay once triggered by the M254 rhythm generator.

The square wave output of the M254 is held low by a resistor, necessary because the M254's outputs are open drain, and fed via a differentiating network to the damped oscillator. A pulse from the output of the M254 will trigger the characteristic instrument sound.

In addition to the output of the damped oscillator based on IC8c and d the tom tom, to give it a more realistic sound, contains a white noise component.

The white noise is produced by the reverse biased zener effect of Q4 and after filtering and buffering, by Q1, with further filtering by Q2, is mixed with the oscillators output to provide a realistic tom-tom sound.

The brush sound consists of filtered white noise, the white noise again being generated by Q4 — the filtering this time being performed by Q3 and associated components.

The clave output is generated by the resonant circuit centered around L1 and C30.

The outputs from the various voice generating circuits are summed and fed to the instruments pre-amplifier.

BUYLINES

Maplin Electronics will be supplying a complete kit of parts for the auto chord, including screened boards. Contact Maplin for details of price. Full constructional details for the auto chord will follow next month.

Next month — full constructional details plus the auto stop board.

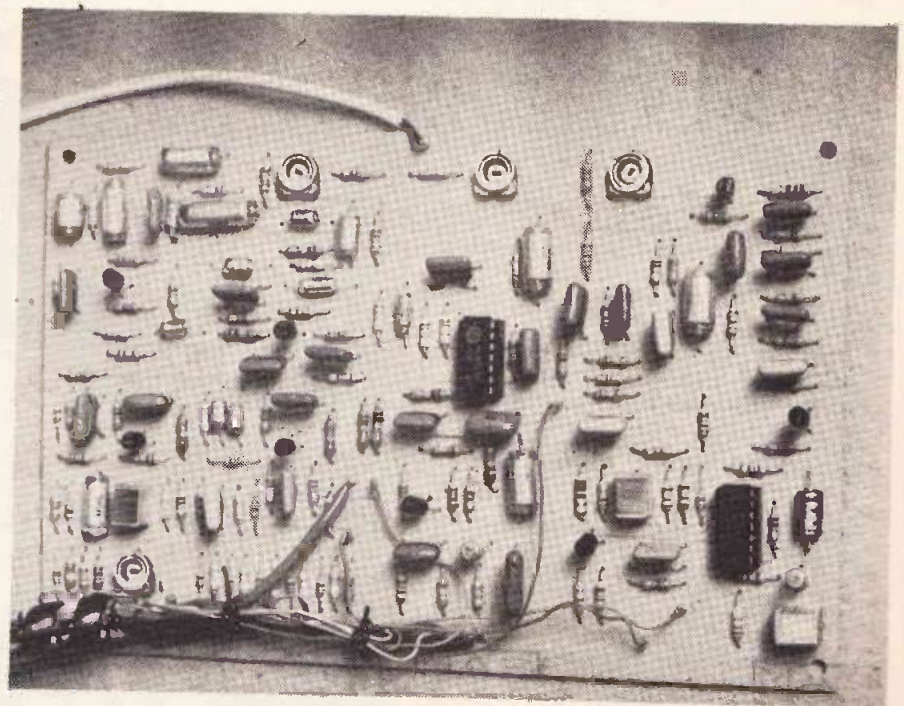

The Sinclair PDM35.

A personal digital multimeter for only £29.95 (+8% VAT)

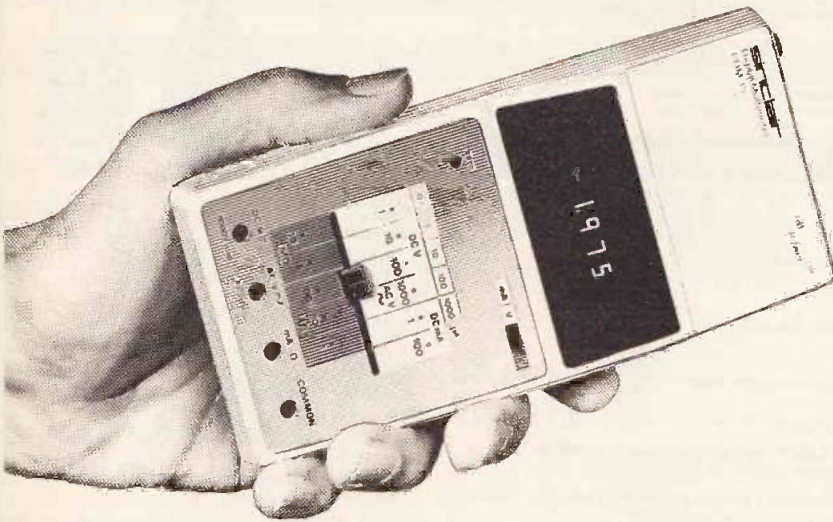

Now everyone can afford to own a digital multimeter

A digital multimeter used to mean an expensive, bulky piece of equipment.

The Sinclair PDM35 changes that. It's got all the functions and features you want in a digital multimeter, yet they're neatly packaged in a rugged but light pocket-size case, ready to go anywhere.

The Sinclair PDM35 gives you all the benefits of an ordinary digital multimeter – quick clear readings, high accuracy and resolution, high input impedance. Yet at £29.95

(+8% VAT), it costs less than you'd expect to pay for an analogue meter!

The Sinclair PDM35 is tailor-made for anyone who needs to make rapid measurements. Development engineers, field service engineers, lab technicians, computer specialists, radio and electronic hobbyists will find it ideal.

With its rugged construction and battery operation, the PDM35 is perfectly suited for hand work in the field, while its angled display and optional AC power facility make it just as useful on the bench.

What you get with a PDM35

- 3½ digit resolution
- Sharp, bright, easily read LED display, reading to ± 1.999 .
- Automatic polarity selection.
- Resolution of 1 mV and 0.1 nA
- 0.0001 μ A
- Direct reading of semiconductor forward voltages at 5 different currents.
- Resistance measured up to 20 M Ω .
- 1% of reading accuracy

Operation from replaceable battery or AC adaptor.
Industry standard 10 M Ω input impedance.

Compare it with an analogue meter!

The PDM 35's 1% of reading compares with 3% of full scale for a comparable analogue meter. That makes it around 5 times more accurate on average.

The PDM35 will resolve 1 mV against around 10 mV for a comparable analogue meter – and resolution on current is over 1000 times greater.

The PDM35's DC input impedance of 10 M Ω is 50 times higher than a 20 k Ω /volt analogue meter on the 10 V range.

The PDM35 gives precise digital readings. So there's no need to interpret ambiguous scales, no parallax errors. There's no need to reverse leads for negative readings. There's no delicate meter movement to damage. And you can resolve current as low as 0.1 nA and measure transistor and diode junctions over 5 decades of current.

Technical specification (+8% VAT)

DC Volts (4 ranges)

Range: 1 mV to 1000 V.
Accuracy of reading: 1.0% \pm 1 count.
Note: 10 M Ω input impedance.

AC Volts (40 Hz-5 kHz)

Range: 1 V to 500 V.
Accuracy of reading: 1.0% \pm 2 counts

DC Current (6 ranges)

Range: 1 nA to 200 mA.
Accuracy of reading: 1.0% \pm 1 count.
Note: Max. resolution 0.1 nA.

Resistance (5 ranges)

Range: 1 Ω to 20 M Ω .
Accuracy of reading: 1.5% \pm 1 count.
Also provides 5 junction-test ranges.

Dimensions: 6 in x 3 in x 1½ in.

Weight: 6½ oz.

Power supply: 9 V battery or Sinclair AC adaptor.

Sockets: Standard 4 mm for resilient plugs.

Options: AC adaptor for 240 V 50 Hz power. De-luxe padded carrying wallet. 30 kV probe.

The Sinclair credentials

Sinclair have pioneered a whole range of electronic world-firsts – from programmable pocket calculators to miniature TVs. The PDM35 embodies six years' experience in digital multimeter design, in which time Sinclair have become one of the world's largest producers.

Tried, tested, ready to go!

The Sinclair PDM35 comes to you fully built, tested, calibrated and guaranteed. It comes complete with leads and test prods, operating instructions and a carrying wallet. And getting one couldn't be easier. Just fill in the coupon, enclose a cheque/ PO for the correct amount (usual 10-day money-back undertaking, of course), and send it to us.

Sinclair Radionics Ltd, London Road, St Ives, Huntingdon, Cambs., PE17 4HJ, England. Regd No: 699483.

To: Sinclair Radionics Ltd, London Road, St Ives, Huntingdon, Cambs., PE17 4HJ.

Please send me _____ qty PDM 35(s)
 @ £32.35 incl. VAT each..... £..... Name.....
 _____ qty De-Luxe carrying cases
 @ £3.24 (incl. VAT) each..... £..... Address.....
 _____ qty AC adaptors for 240V
 power @ £3.24 incl. VAT each..... £.....
 Post and packing please add £0.65
 I enclose cheque/PO made payable
 to Sinclair Radionics Ltd for
 (indicate total amount)..... £.....

I understand that if I am not completely satisfied with my PDM 35, I may return it within ten days for full cash refund.

 **sinclair**
 World leaders in fingertip electronics

SEIKO 20% OFF!

Analogue and digital from stock or to order

NEW

**FB 011 ALARM/CHRONOGRAPH
FH 003 CALCULATOR
WATCH**



RRP £135

£104



RRP £165

£127.50

FB 018 Gold plated (£150) **£120**

CITIZEN LARGE REDUCTIONS

On most quartz analogue and digital models

FAIRCHILD TIMEBAND

C6110 Mains digital alarm clock

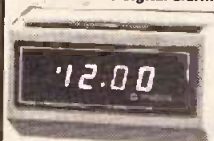

STILL THE BEST!
Large LED display 24-hour
alarm 9 minute snooze,
concealed controls
3 1/4 x 5 1/2 x 3 1/8 ins.

Black or white

£10.95

FROM CASIO — OF COURSE

NEW

**BEDSIDE
TRAVEL
ALARM
CLOCK**

Okay, genius, so you KNEW Casio would bring one out soon!
You were right to wait.
Provisional spec. LARGE 6 digit LCD display Night light
Alarm, Alarm/Timer, Stopwatch.

£19.95

AQ-1000 CALCULATING ALARM CLOCK PLUS 3-WAY STOPWATCH

Hours, minutes, seconds, am/pm, 24
hour Alarm with sign. Stopwatch: Net
times, lap times, 1st & 2nd place times
from 1/10 sec. to 10 hrs. with ST & LAP
signs. Calculator: 4 key memory, %, √ 1
year batteries, ± 20 secs/month.
1/4 x 2 3/4 x 4 3/8 in
RRP £26.95



Our Price **£21.95**

CQ-81 CALCULATING ALARM CLOCK. Plus 2 Alarm/ Timers. 24 hour alarm and alarm/timers, 6 digit LCD clock. One year battery life. 1 1/2 x 2 3/4 x 5 inches (RRP £22.95)

£17.95

FX-8000. 41 sc. funct. 1/100 sec stopwatch 2 x 5 Alarm/Timers (£35.95)

£29.95

MINI CARD CALCULATORS 1/8 x 3 1/2 x 2 1/8 ins. LC-78. Full memory, %, √ K **£16.95**

FX-48 Math. Card. Full SC, with S.D. **£19.95**

ST-24 Card Time. 24 hour stopwatch (or clock), 2
Alarm/Timers, Calc. as LC-78 **£19.95**

All Casio scientifics. Lowest prices

ST-1. Four way stopwatch **£24.95**

CARTRIDGE T/V GAMES

OPTIM Coronet 600 **£48.50**

Cartridges from £9.95

FAIRCHILD TIMEBAND Grandstand **£119.95**

Cartridges from £12.50

ATARI Video Computer System **£169.95**

The very best available to date!
Cartridges from £14.95

★ SPECIAL INTRODUCTORY OFFER

FREE extra cartridge worth £14.95 with Atari

SAVE £££s WITH THE MONTEL

Telephone call charge, calculator and clock UK model

£28.15, International **£38.50**. State colour

WATCH BATTERIES 65p each D.I.Y. KIT 35p (with
battery order).

★ THIS MONTH'S STAR BUY ★



**CASIO 45CS-22B
CHRONOGRAPH**
Hrs, mins, secs
or Hrs, mins,
date, Day,
date, mth, yr
Dual time
12 or 24 hr

Chrono
Net, lap
and 1st & 2nd place
times. 1/100 second
to 6 hrs. with rollover

Stainless steel, Mineral glass
Water resistant to 100 feet.

£49.95

TEXAS LCD ANALOGUE

TODAY'S MOST ADVANCED ELECTRONIC WATCH

Hours, minutes, seconds,
Perpetual calendar
Chronograph timing
from 1/10 second to
12 hours
Dual Time
Mineral glass face



£179.95

Stainless steel case, bracelet

10 micron gold plated

£199.95

SOLAR powered watches — so called.
Misrepresentation? We WON'T sell them.

LED display watches — we don't sell them. Send us a
S.A.E. and we will tell you why not.

PH-ALARM and ALARM CHRONO

ALARM (Left)

Hours, mins,
secs or date,
day, am/pm
Day, date,
month, year

£28.95

CHRONO

Functions
as above
plus

Chrono. Measuring net, lap and 1st & 2nd place times from
1/100 second to 1 hour, with rollover

All stainless steel, mineral glass

£39.95

GBM, 6 DIGIT and ALARM WATCHES

16 x 3 (Left)
6 digits, 6 functions

£13.95

ALARM
18 x 3 (Right)
6 digits
6 functions +
alarm setting
5 minute snooze
£27.50



ANALOGUE

IBICO 700. Cushion shape, Day, Mineral glass face. **Water
resistant to 100ft. £28.95**

LADIES' LCD WATCHES

5 functions, Backlight. Gold or silver finish **Dress Watch.**

PH.L2

Matching
Milanese
bracelet

£14.95

Cocktail

Internal
bracelet
(4 other
models)

£18.95



CASIO LADIES' LCD WATCHES



7 + 2 functions
27CL-15B
Round (Left)
(£35.95)
£29.95

27CL-17B
Stopwatch
(£49.95)
£39.95

Send 25p for our illustrated catalogue. Price include VAT and
P&P. Send your cheque, PO or phone your credit card no.
to —

CASIO QUALITY

All CASIO watches have a calendar display, night illumination,
mineral glass and stainless steel cases, water resistant to
100 ft (except sports watches — 66)

SPORTS WATCHES

F-100

Left, 9.45 mm
(£29.95)

£24.95

52QS-14B
Right 8 mm
(£44.95)

£34.95



Up to **25 functions**. Net, lap and **first and second place**
times to 1/100th sec. F-100. Resin case, strap 52QS-14B.
S/S encased version and bracelet.

4 DIGIT WATCHES (except World Time). Hours, minutes,
ten seconds, seconds by flash, am/pm. Day, date, month,
Stopwatch. Dual time (except 31QR-20B)



31QR-20B Left, 4 digit
(£31.95)

£26.95

51QR-19B. 6 digit
(£35.95)

£29.95

6 DIGIT WATCHES (except Sports and Alarm). Hours,
minutes, seconds, day **OR** Hours, minutes, date, day, ten
seconds, seconds by flash, day, date, month, year. Select-
able 12 hour (with am/pm) or 24 hour clock.

54QS-16B
Left, 6 digit
(£44.95)

£34.95

54QS-15B
6 digit
(£49.95)

£39.95



CHRONOGRAPH. 6 digits as above, with stopwatch
measuring net, lap and 1st & 2nd place times from 1/100
sec to 6 hrs. Dual time facility.

45CS-22B
Chronograph
Left, 6 digit (£64.95)

£49.95

28CS-11B
World Time (£74.95)

£59.95



WORLD TIME WATCH. The time in ten capitals plus one
optional time. Instant summertime correction. Hrs, mins, 10
secs, secs by flash. Perpetual calendar, day, date, month.
Running digital seconds display.

ALARM WATCHES

25CR-16B
Round (£64.95)

£49.95

25CS-16B
Square (£74.95)

£59.95



Hours, mins, seconds (or hrs, mins, date) day, am/pm. Day
date, month, year. 24 hr. alarm, on/off indicator.

ULTRA SLIM DRESS WATCHES (Not 24 hour)

53CS-18B
Left, 4 digit (£69.95)

£54.95

49CS-25B
6 digit (£79.95)

£64.95



Not illustrated 53CS-19B, 4 digit, barrel shaped, **£54.95**.
49CS-24B, 6 digit (£74.95) **£59.95**. 53CS-17L. Gold
plated, on strap (£84.95) **£69.95**.

TEMPUS

Dept. ETI, Talk Of The Town
19/21 Fitzroy Street
Cambridge. Tel. 0223 312866

electronics today

international

What to look for in the December issue: On sale Nov 3rd

ETI LIGHT SHOW

HANDS UP all those who've never been to a disco. None? Good — that means you've all seen sound-to-light units in action, although it's more than likely it was a normal three-channel affair. Usually boring, are they not?

Well ETI plans to change that next month; ours has five frequency channels, with individual level controls on each channel. Control of the lights is comprehensive to say the least. You can run the unit as a straight sound to light, or have it strobe all lights. At a

speed dependent upon music level (not volume — the unit is independent of that!) or hand over control to an internal digital circuit which produces some superb random effects. If you fancy a five colour manually controlled strobe unit it can do that as well!

Each channel handles up to 500 W of lighting, and a complete kit of parts will be available from Powertran, who designed this project especially for ETI.



Electronics in Model Railways

An essential part of the education of any young man is his electric train (checking with ETI technical staff shows all eight had one — and five still have). Most of us however remember the controls as crude; today things are changing — sophisticated electronic controls are perfectly suited to model railways and the manufacturers are about to announce some dramatic advances. We take a look at what's happening.

CURVE TRACER

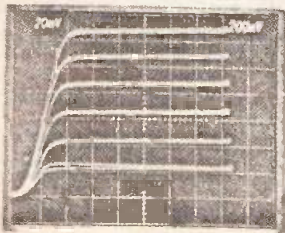

Explaining the shape of Voltage-Current characteristics of diodes, transistors and other non-linear devices is usually dull as it normally involves a tedious plot of static, experimental data.

A more elegant solution is available to anyone with a DC coupled scope capable of taking an external X-input. Next month we carry a project with the additional circuitry necessary to do this yourself.

How It Works



In the November issue we begin a new type of article. The idea came to us when discussions with experts in one area of electronics admitted to almost total ignorance of other areas — especially commercial circuitry. Mass-produced electronics use techniques which are not widely understood elsewhere — we hope to put that right. In the first of this occasional series we have asked Gordon King to dissect a Thorn Monochrome TV; we shall show the complete circuit and explain the function of each stage. It's not done as a beginners series but to give those outside this field the true "Inside Story."

Car Anti-theft System

A simple project to build but sophisticated in its operation. It is a comprehensive system that incorporates several features of large and expensive commercial systems and using state-of-art techniques it is extremely reliable. A kit will be available of the whole project.

INDEX

A complete listing of all we've carried in ETI since our last index (which was carried in April 1977) and went back to the first ever ETI). As our research shows that 96% of readers never throw away their copies it should be useful to most of you.

computing today No.2

Win a TRITON Computer



Want to get your hands on a Triton Computer Kit but can't afford it (yet)? In No. 2 of our new supplement Computing Today, we have a free-entry competition for one to be won. If you've read this far you'll probably know what it's worth — but in case you don't it's about £300.

Microprocessors by Experiment

Learn about microprocessors — not from some abstract description of a make believe MPU but by hands on experience with an MPU system. The series, based on the MK14 development kit, will take you through the operation of the SC/MP MPU and show you how to use it to do everything from control your heating system to land on the moon.

I/O for 6800

The microprocessor user rapidly arrives at the need to understand and apply input/output circuitry to interface peripheral equipment to the computer system. A standard choice, when using a 6800 microprocessor, is to employ a Peripheral Interface Adapter (PIA). Many engineers now buy ready-built systems then wish to utilise the PIA as straightforward outputs and inputs. When data sheets are consulted they are found to give concise yet complete hardware and software information. The user of a ready-built system needs help in simply getting the PIA to act as outputs and inputs without becoming involved in the intricate details needed by designers of microcomputer boards. This article aims to give this help.

Features mentioned here are in an advanced state of preparation as we go to press but circumstances may affect the final contents of the next issue.

CALCULATORS

SCIENTIFIC

SPECIAL OFFER
TEXAS T159 together with PC100B
(Complete as manufacturer's specifications)
£285.00

- TEXAS/HP Accessories available
*TEXAS T159 (New Card prog 960 prog steps of 100 mem) **£156.50**
*TEXAS T158 (New Key prog 480 steps or 60 mem) **£60.00**
*TEXAS PC100B (New updated Printing Unit for T158/T159) **£140.00**
*TEXAS T157 (Key Prog B Mem 150 Key Strokes / 50 Prog Steps) **£26.20**
TEXAS T133 (New — same spec. as T130, but 3 Mem) **£13.95**
TEXAS T145 (New updated version of the Texas T140) **£19.95**
*TEXAS 42MBA (10 Dig Fin / Stat Prog 12 Mem 32 key strokes) **£42.95**
*TEXAS TI PROGRAMMER (Hexadecimal Oct) **£46.50**
*TEXAS T151/iii (New B Dig + Exp 10 Mem 32 Prog Steps Stat/Sci) **£26.30**
*TEXAS T125 (new LCD Sci/Stat) **£18.90**

"SLIM-LINE" Chronograph BARGAIN OFFER

You will not believe the luxury of this "Slim-Line" 12 function Chronograph until you have worn it... until you have enjoyed the compliments it generates.

The "Slim-Line" Chronograph gives continuous easy to read LCD display of hours, minutes, seconds, AM/PM. At the touch of a button you have date — month date — day of week — reverting to normal display time at the release of the button.

Press again for immediate stop watch/lap time facility to 1/100 second. The "Slim-Line" even has a powerful back light for easy night use, the casing is chrome finished with matching linked bracelet.

We are so certain you will be delighted and satisfied with this "Slim-Line" Chronograph that in addition to the One Year Warranty we are offering a 14-day money back guarantee if you are not entirely satisfied.

ONLY £27.50 + £1.00 p/p ins. Send cheque/P.O. or order via Barclay/Access credit card Today under our Special 14-Day Trial Offer.

*TEXAS T158 with Applied Statistics **£80.00**
*TEXAS T159 with PC100B and Applied Statistics **£305.00**

AUTUMN SALE
TEXAS T159 Calculator (complete as manufacturer's spec. — master module, charger, etc.) PLUS statistics modular and extra set of 40 Blank Prog Cards with wallet, etc.
ONLY £180

- *CBM S61 (Stat + Sci 6 Mem M & S Div Chi Sq Dis Lin Regr. Etc.) **£46.00**
*CBM M55 (Adv Math / Sci 6 mem) **£46.00**
*CBM 4190R (Scient Pre-Prog) **£25.50**
*CBM Pro 100 (72 Step Prog) **£29.50**
*HP 19C (Con Mem Key prog Printer) **£163.00**
*HP 29C (as 19C but no Printer) **£110.00**
*HP 33E (8 mem Pro Sci / Stat) **£64.00**
*HP 25C (Key Prog Con Mem) **£99.00**
*HP 27 (10 Mem Sci / Fin / Stat) **£73.50**
*HP 31E (New Sci replaces HP 21) **£35.00**
*HP 67 (Card Prog 224 Steps 26 Mem) **£277.00**
*HP 97 (Fully prog with Printer) **£466.50**
All HP range avail, inc new E range
*CASIO FX201P (Sci, 11 mem, 127 step Key prog) Fortran System **£44.50**
*CASIO PRO FX1 (127 Step Card Prog 11 Mem — Fortran System) **£99.00**
CASIO FX360 (New 10 Dig + Exp 7 Mem 8) (St. Div Lin Regr. Etc.) **£45.00**
CASIO FX5000 EP (Alphanumeric Sci / Stat Desig Printer 10 Dig + Exp 7 Mem, etc.) **£185.00**
CASIO AQ 1000 (LCD Cal 3-way Stop Watch / Alarm) **£20.00**
CASIO CD1 (4 tone alarm / Cal) **£24.50**
CASIO FX3100 (New version of FX3000-LCD Sci / Stat / Div Poles Rec. etc.) **£22.50**
CASIO FX8000 (as above + Stop Watch / Alarm) **£27.73**

LOW PRICED COMPUTING THE COMMODORE PET COMPUTER

with 8K bytes RAM 2001-B

A complete personal computer that operates anywhere by simply plugging into Mains supply. Allows communications directly from BASIC to IEEE — 488 standard devices —

Cassette, Video Display Unit and Keyboard built into PET
Fully guaranteed Warranty by CBM
complete only **£643**

FREE — Mains/Charger included

GOODS FULLY GUARANTEED
PRICES EXCLUDE VAT (ADD 8%)
BUT INC P&P CHEQUE WITH ORDER

Company / hospital and Government orders accepted by phone
Barclaycard / Access accepted by phone

Tel. 01-455 9855

EXPORT ORDERS WELCOME
Air Freight / Air Post Delivery
Quotations on request. Payments via Letter of Credit / Int
Money Order / American Express, etc

MOUNTAINDENE LTD.
22 Cowper St., London, EC2

ETCH RESIST TRANSFER KIT SIZE 1:1

Complete kit 13 sheets 6in x 4½in
£2.50 with all symbols for direct application to P.C. board Individual sheets 25p each. (1) Mixed Symbols (2) Lines 0.05 (3) Pads (4) Fish Plates and Connectors (5) 4 Lead and 3 Lead and Pads (6) DILS (7) BENDS 90 and 130 (8) 8—10—12 T O 5 Cans (9) Edge Connectors 0.15 (10) Edge Connectors 0.1 (11) Lines 0.02 (12) Bends 0.02 (13) Quad in Line

FRONT AND REAR PANEL TRANSFER SIGNS

All standard symbols and wording. Over 250 symbols, signs and words. Also available in reverse for perspex, etc. Choice of colours, red, blue, black, or white. Size of sheet 12in x 9in. Price **£1.**

GRAPHIC TRANSFERS WITH SPACER ACCESSORIES

Available also in reverse lettering, colours red, blue, black or white. Each sheet 12in x 9in contains capitals, lower case and numerals ½in kit or ¼in kit. **£1** complete. State size

All orders dispatched promptly.

All post and VAT paid

Ex U.K. add 50p for air mail

Shop and Trade enquiries welcome
Special Transfers made to order

**E. R. NICHOLLS
P.C.B. TRANSFERS
DEPT. ET1/9
46 LOWFIELD ROAD
STOCKPORT, CHES.061-480 2179**

SUPER SAVERS ALL FULL SPEC.

7490N—10p, £8—100, 7460N—10p, £8—100,
74190N—15p, £12—100, 74155—35p, 741 (8DIL)
17p. Min. order 10 of one type 100 + POA. P/P 20p.

SLIDER POTS PIHER 47K LOG TRACK 70mm,
OVERALL 85mm, SINGLES 20p, £15—100, DO-
UBLES 50p, £40—100 MIN ORDER 10, 100 + POA.
P/P 20p

SUPERB STEREO CASSETTE DECKS, BRAND
NEW, PIANO KEYS, 6V MOTOR, END OF TAPE STOP,
DIGITAL COUNTER, HEADS, PULLEYS, ETC., AS
USED IN NATIONAL PANASONIC MUSIC CENTRES
VERY HIGH QUALITY **£8.75p + £2 P/P**

VERO EDGE CONNECTORS 22X 22, TYPE 2245/
2-7431 **40p**, 42X42 w/w KEY AT 7 TYPE 1360/2 **£1**,
P/P 20p

TRIM POTS 50Q T05 20p, 100Q CERMET 20p,
100Q PAINTON PCB 20p, 200Q DITTO 20p, 250Q
DITTO 20p, 500Q DITTO 20p, 1K DITTO 20p, 2K
DITTO 20p, 2K HELITRIM 20p, 5K PCB 20p, 1MEG
SKELETON MIN VERT 12p, P/P 20p.

CANNON "D" TYPE PLUGS / SKTS. 15p-50p,
SKT—50p, 25p-60p, SKT 60p, 25 RIBBON PLUGS
90p, SKTS 90p, 37 PLUG 80p, 50 SKT **£1.20**,
50—W /WRAP COVERS SKTS **£1.30**.

COVERS WITH RETAINERS, 15 WAY 60p, 25 WAY
80p, 37 WAY **£1**, 25 WAY PLASTIC (3M), 50p. ALL
ABOVE LIMITED P/P 20p

All enquiries s a e please. Cat. s a e 8 x 6 free with goods

Now distributor for Mutek Products including Ides Micro Systems. In stock, Video Interface board, 16 line, 64 characters, data and control inputs, video output. Ideal for Micro Processor use. With full documentation, **£81**. P/P plus insurance, **£1**. Brochure available, s a e.

POCKET PAGER

Miniature crystal controlled FM RX Single Superhet around 30MHz 450 KHZ IF contains various tone detectors. Ideal for modifications to 27 MHz Radio Control OR 28MHz Amateur Band. Complete, without 2.5v DEAC + circuit of similar type, **£3.95**. P/P 25p.

SEMICONDUCTOR OFFERS ALL FULL SPEC.

Common anode 0.3 7 seg displays Toshiba type TLR303 65p, F.E.Ts similar to 2N3819 18p, Mosfet Sim to 40673 35p 3N140 Mostets 50p, M203 Dual Matched Pairs Mostets Single Gate per F.E.T. 40p Intel 1024 bit MOS Rams 95p, Mullard BB113 Triple Varicap Diode 35p, MC1310 Stereo Decoder I.C.s £1.20, CD4051 CMOS 50p, 741 8pin D.I.L. 23p, 500v 800mA Bridge Rect. (ex equip) 25p, 1N4002 100v 1A Diodes 4p, 14005 800V 1A Diodes 7p, E.H.T. SIL Rec 15kV 2.5mA 15mm x 5mm 30p, 7812 12v 1A Plastic V. Regs 95p, Min. Nixies ITT 5870Si 13 x 6mm Fig Size 85 Nixies ITT GN/9A 13 x 8mm 65p 0.2 or 0.125 Red LEDs 12p each, MANS3A 3mm LED Displays 50p, 741 S. (wide bandwidth) 35p, LM380 80p, LM381 90p, ZN414 75p, TL305 Alpha-numerical Displays with LCD. £2.75 ORP61, Mullard, new, boxed 30p, Special Offer SCS TB8800Cs 10 for £5.00.

MICROPHONES, EM506 Condenser Mikes: Uni-directional, F.E.T. Amp. Dual imped., 50K/600ohms, 30-18KHz on/off switch. £11.00. Miniature Tie Pin Condenser mike 1K imp. omni-directional, uses hearing aid battery (supplied) £4.95. Grundig Electret Inserts with built-in F.E.T. Preamp £1.50. Crystal Mike Inserts 37mm 45p. Electret Condenser Mikes 1KQ Imp. with std. Jack Plug £2.85. Cassette Condenser Mikes with 2.5 and 3.5 Jack Plugs £2.85. Standard Cassette Mikes 200 ohm Imp. with 2.5 and 3.5 Jack Plugs £1.20.

MORSE KEYS — Hi-Speed Type all metal £2.25. Plastic Morse Keys 95p. Belling Lee L4305 Masthead Amplifiers and 240v AC power unit Group A UHF Only £7.50

CRYSTALS, 300KHz HC6U 40p 0.1 Edge Connectors, 64 way 65p 32 way 40p

RELAYS, Min. 220v AC Sealed Relay 2 pole C/O 45p, 240v AC Sealed Relay 3 pole C/O 5amp Contacts 11-pin base 80p, 12 volt 4 pole N/O Reed Relay 20p, Min. 24v DC Sealed 2-pole C/O relays 3amp contacts New 55p 12v DC 4pc o. open type new 50p each

MOTORS 1.5 to 6v DC Model 20p 115v AC min. 3 R P M. with Gearbox 30p 240v AC Synchron Motor 1/5th R P M. 65p, 240v AC Synchron Motor 1/24th R P M. 65p, Crouzet 115v AC 4 R P M. Motors, new 95p 12v DC 5-pole 35p

BOXES, Black A B S Plastic with brass inserts and lid, 7.5 x 56 x 35mm 40p, 95 x 71 x 35mm 49p, 115 x 95 x 16mm 57p, 225 x 130 x 84mm £1.95

TOOLS, Radio pliers, 5in. insulated handles £1.40. Diagonal side cutters, 5in. insulated handles £1.40

MAINS TRANSFORMERS, all 240v AC primary. Postage shown in brackets per transformer
6.0-6 100mA, 9.0-9 75mA, 12.0-12 50mA, 75p each (15p)
0.4-6.9 150mA, no mounting bracket, 65p (20p), 12.0-12 100mA, 95p (15p), 12v 500mA, 95p (22p), 12v 2 Amp, £2.25 (45p), 12v 4 Amp, £2.75 (54p), 15.0-15v 1 Amp, £2.10 (45p), 30.0-30v 1 Amp, £2.75 (54p), 0-12-15-20-24-30v tapped at 2 Amp, £4.50 (54p), 20.0-20v 2 amp, £3.60 (54p), 25v 1.5 Amp, £1.45 (45p), 18v 1.5 Amp rectified, £2.00 (45p), 35v 2 Amp, 2.5v 2 Amp toroid, £2.95 (54p), 20v 2.5 Amp, £2.20 (54p), 1.1 Xenon triac pulse transformer, 30p

SWITCHES — Min Toggle SPST 8 x 5 x 7mm 45p, DPDT 8 x 7 x 7mm 60p, DPDT Centre Off 12 x 11 x 9mm 75p, DPDT C/O Sliders 20p, R/S, Single Pole C/O Push Buttons 45p, Roller Micro Switches 15p, Min. Micro Switches 13 x 10 x 4mm 20p, Min. Push to make or push to break Switches 16 x 6mm 15p

SOLDER SUCKER, Plunger type, eye protection, replaceable nozzle, high suction, £4.95. Reed switches 28mm norm. open, 6p each

TAPE HEADS — Cassette Stereo £3.00, BSR MN 1330 ¼ Track Dual Impedance Rec / Playback 50p, BSR SRP90 ¼ Track Stereo Rec / Playback £1.95, TD10 Assemblies, two heads, ¼ Track Rec. / Playback Staggered Stereo with built-in erase per head £1.20, Tape Head Demag 240v AC £1.95

BUZZERS — GPO Type 6-12v 20p, Min. Solid State Buzzers 6.9-12 or 24v 15mA 75p, All Metal Buzzer, 30mm diam, 6-12 volts high tone 25p

UHF TV Transistorised Push Button Tuners (not Varicap) new and boxed, £2.00

MURATA MA401L 40kHz Transducers, rec./send, £3.25 pair.

METERS — Grundig Batt. Level Meter 1mA 40 x 40mm £1.10, Min. Level Meter 200µa 25 x 15mm 75p, Ferranti 600v AC Meter £3.95

EDGE METER — Large scale 0-100, new £2.75

POT CORE UNIT, Has 6-pot cores, including 1 FX2243 (45mm) and 2 FX2242 (35mm), 3 20mm Panel Fuseholders, 3 103 SL Power Transistors on heat sink, panel with various transistors and diodes with a 5-amp plastic S.C.R. New £1.75 + 75p P&P

LA1230 adj. core 15mm dia 14mH-18mH, HI Q, 10p each

8 TRACK 12 volt motors new, £1.25
CASSETTE MOTORS 6 volt new £1.25

SOLENOIDS — 240v AC 45p, 12v DC H Duty 75p, 240v 25lb pull 2 travel £3.95

12-WAY MOTORIZED CAM UNITS, 50v AC low rev motor driving 12 C/O micro switches, supplied with a capacitor for 240v AC use. Ex. equip. £1.95 + 35p P&P

13 Amp rubber trailer extension sockets, 38p

8 WAY RIBBON-CABLE, min solid core, 15p metre

POSTAGE 30p UNLESS OTHERWISE SHOWN (EXCESS POSTAGE REFUND WITH ORDER) OVERSEAS POST AT COST VAT INCLUDED IN ALL PRICES

S A E FOR LISTS

ORDER ADDRESS

L. B. ELECTRONICS
43 WESTACOTT, HAYES
MIDDLESEX UB4 8AH

PROGRESSIVE RADIO
31 CHEAPSIDE, LIVERPOOL 2
051-236 0982

GAIN CONTROL

PART 2

To conclude his survey of electronic gain control methods, Tim Orr presents us with more circuits which vary from a light bulb compressor to a markspace modulated universal filter unit, and a noise gate/expander.

Basic Limiter Circuit

Most professional limiter circuits use a FET as the variable gain element. Relatively low distortion with a reasonable signal to noise ratio can be obtained. A basic limiter circuit is shown this being no different to previous circuits except for the variable gain element.

When a relatively small voltage (20 mV) is applied to the drain source of a FET, it acts like a fairly linear resistor. As the gate source voltage is varied, this resistor (RDS) also varies.

In fact the channel resistance RDS is inversely proportional to gate source voltage V_{GS} . When V_{GS} is 0V, then RDS is at its generally minimum resistance (R_{ON}) which can be as low as 5R, but it is generally more like 100R. When V_{GS} exceeds the pinch off voltage (V_p or $V_{GS\ off}$) the channel resistance goes up to several hundred Megohms. So a junction FET can be used as a voltage controlled resistor, except that R_{ON} and $V_{GS\ (OFF)}$ tend to vary widely from device to device. However with a bit of perseverance suitable devices can be selected and made to work.

One circuit trick that greatly reduces distortion is shown here. Half of the audio signal at the drain of the FET is presented to the gate. This is superimposed on top of the control voltage and produces a distortion cancelling effect. Distortion levels below 0.1% can be achieved using this technique.

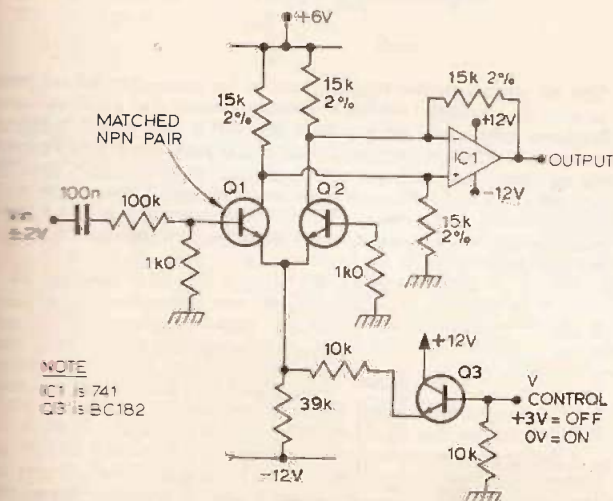
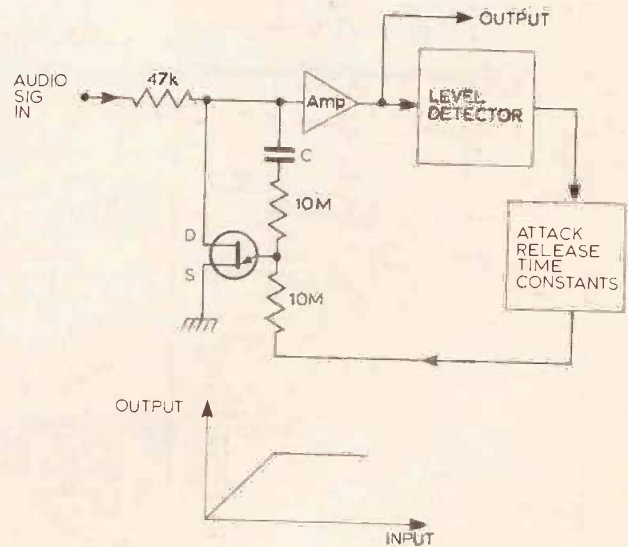

Transistor VCA

A circuit similar in operation to a CA3080 can be constructed with a matched pair of transistors and an op amp. Transistors Q1, 2 form a differential transistor pair which is used to steer whatever current is available between the two collectors, just as in the CA3080. The difference between the collector currents is equal to the product of the input voltage times the current I_{EE} times a constant. This difference is extracted by the differential amplifier IC1. The current I_{EE} is controlled by Q3. As the control voltage goes positive, Q3 robs most of the current flowing down the 39k resistor, and hence I_{EE} and the output of IC1 decrease.

Two Channel Low Level Expander/Noise Gate

NOTE

IC1 IS $\frac{1}{2}$ NE570
 IC2 IS CA3140
 D1, D2 ARE 1N4148

THRESHOLD	RA/RB
-36 dBm (33mV ptp)	30
-46 dBm (10mV ptp)	100
-56 dBm (3.3mV ptp)	300

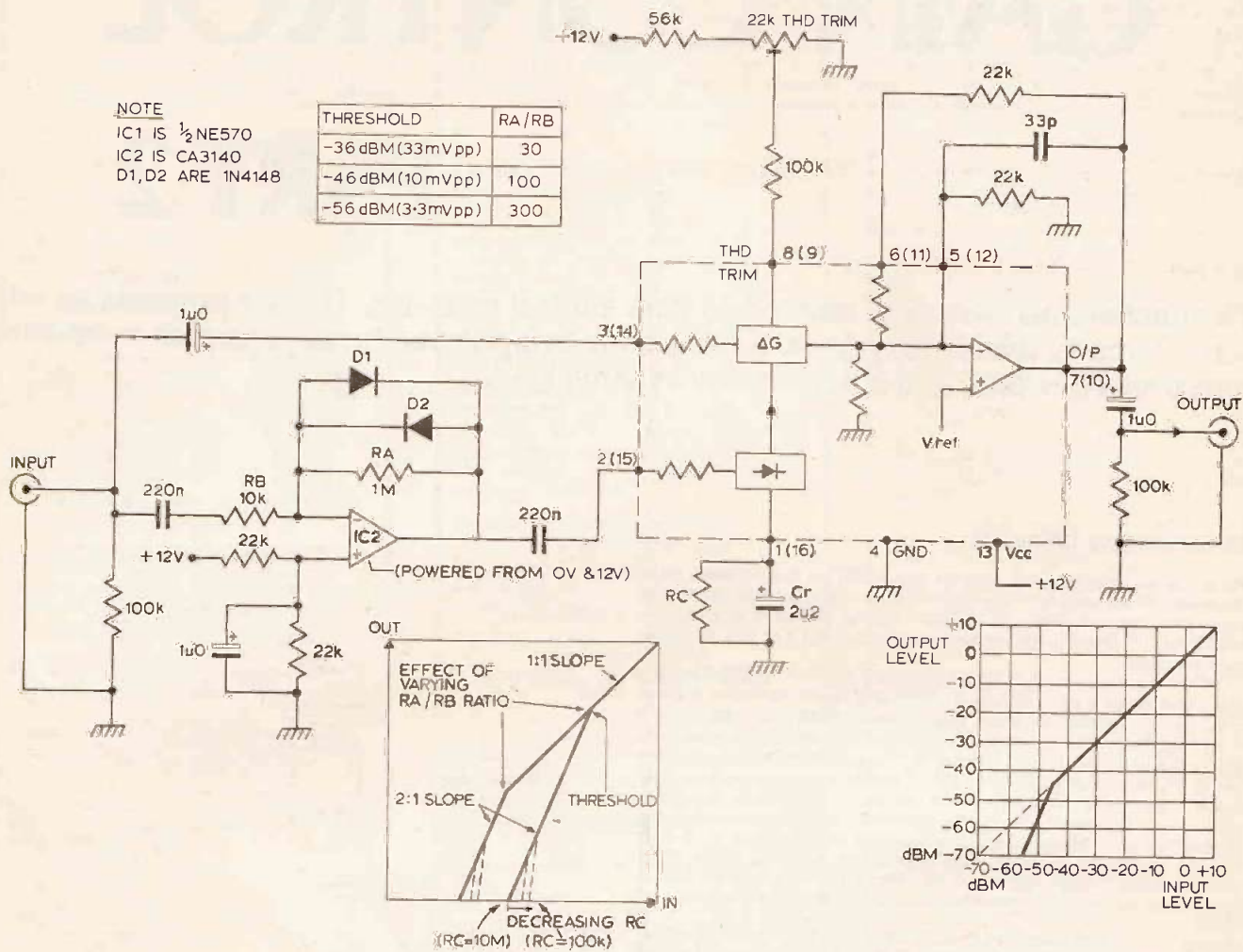

It is often required that a rather noisy signal be cleaned up a bit. This is not possible to do continuously, but it is possible to clean up noise in what was initially the gaps. The results of this cleaning up process can quite often be heard when telephone conversations from "foreign correspondents" are broadcast.

By turning down the signal level in the gaps, (by performing a low level expansion) the perceived sound quality improves dramatically.

The circuit performs just such an expansion. The input signal passes through the variable gain cell and then appears at the op amp output. The gain of the gain cell is controlled by the signal coming from IC1. This is a high gain amplifier with diode clamping, so that the output swing is limited to about 1V0 ptp. Therefore for input signals of 10 mV ptp to 10 V ptp, the output of IC1 remains at about 1V0 ptp to 1V2 ptp.

So, for this range of input voltages the gain of the gain cell remains roughly static. Now when the input level drops below 10 mV, the output of IC1 will start to fall and so will the gain of the gain cell. This produces a 2:1 downwards expansion curve, which means that the output then gets quieter at a rate faster than the input. To accentuate this effect, a bleed resistor can be placed in parallel with C.

The resistor robs some of the current that would have otherwise gone to the gain cell and causes the input output curve to roll off much more rapidly at low signal levels. Also, by varying the resistor ratio of RZ/RB, the expansion threshold level can be altered.

Incredibly Simple Compressor

Not all gain control systems need be complicated or indeed active. One product which I saw advertised was a compressor to help prevent loudspeaker overloads. All it was was a lightbulb in series with the loudspeaker. When the power exceeds a certain level, the lamp will turn on, glow, its resistance increases dramatically and hence a bigger percentage of the power output is dissipated in the lamp. A nice, simple solution, but I think it would require some experimentation to find the right sort of car headlamp bulb!

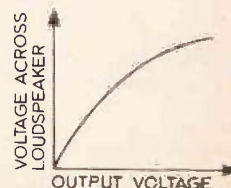
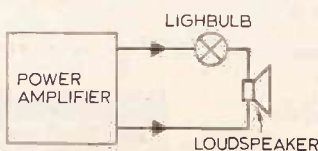

Switched Frequency Low Pass Filter

In this example the effective resistance is switched by using 4016 gates. The filter is a lowpass Butterworth and by turning gates A or B ON or OFF the cut off frequency can be altered. This allows the filter control to be physically remote or even to be computer controlled. Mark Space modulation of A and B would enable continuous control over the cut off frequency.

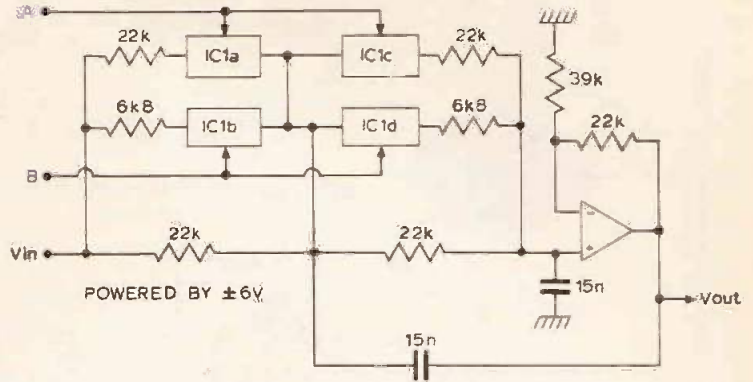

Four Quadrant Multiplication

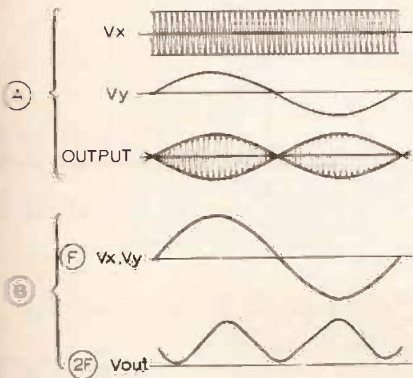
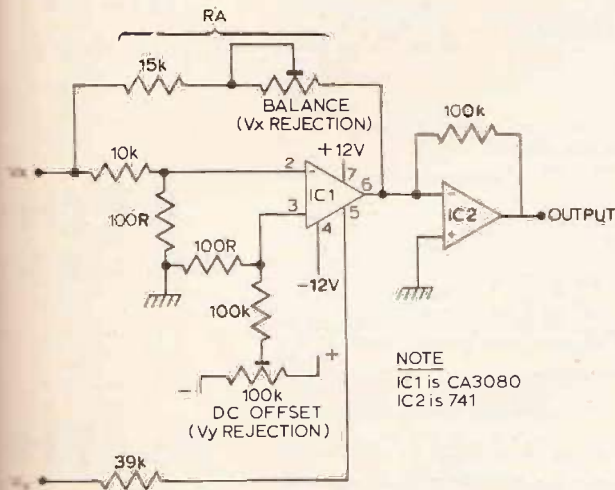

By using a few circuit tricks, the CA3080 can be made to perform 4 quadrant multiplication. In fact the CA3080 performs 2 quadrant multiplication and the trick is to move the axis on the multiplying graph. If we ignore the RA resistor chain then we have a 2 quadrant multiplier circuit similar to that shown previously. Imagine that V_x is a 1kHz sine wave, 1 V_{rms} and V_y is $\pm 0V$. The output of IC2 is a sine wave of fixed amplitude. Now if we connect RA, and adjust the balance control, it will be possible to cancel out the output, because the signal coming from IC1 is out of phase with that from the RA resistor chain. So with V_y set at 0V there is no output for IC2. If V_y goes +ve, the output of IC1 will become greater than the current via the RA chain and the output of IC2 will grow.

If V_y goes -ve the current through the RA chain will exceed that from IC1 and the output of IC2 will grow, the phase being opposite to that when V_y was a sine wave from an oscillator, then this circuit could be used to generate ring modulation effects.

When V_y is set up 0V there may be some V_y breakthrough and this can be minimised by adjusting the V_y rejection preset.

	①	②	③	④
A	OFF	ON	OFF	ON
B	OFF	OFF	ON	ON
F _c	500Hz	1kHz	2kHz	2.5kHz

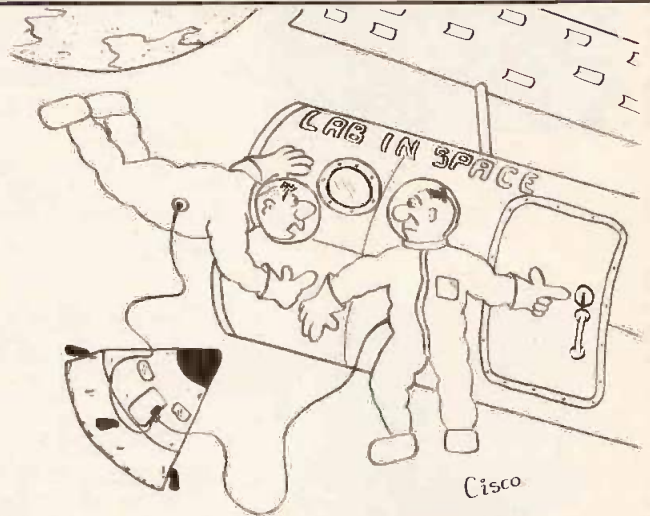
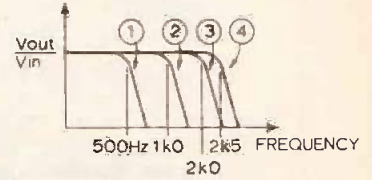

"No. I thought you were supposed to bring the key!"

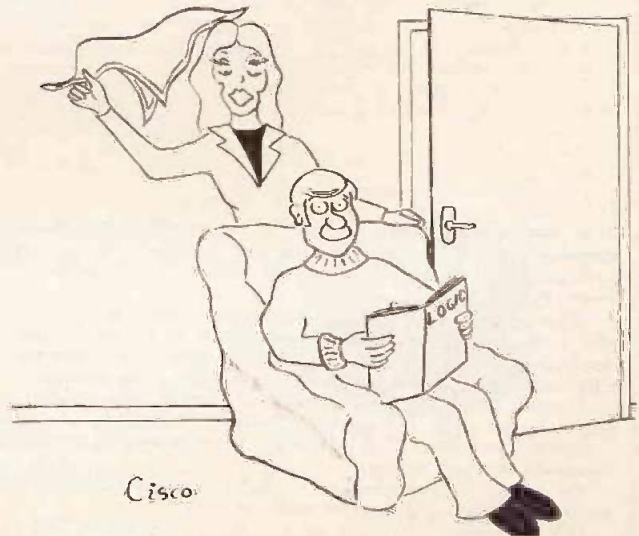

"Forget about RAMS, ROMS AND PROMS, darling... we've got to talk about PRAMS!"

Markspace Modulated Universal Filter

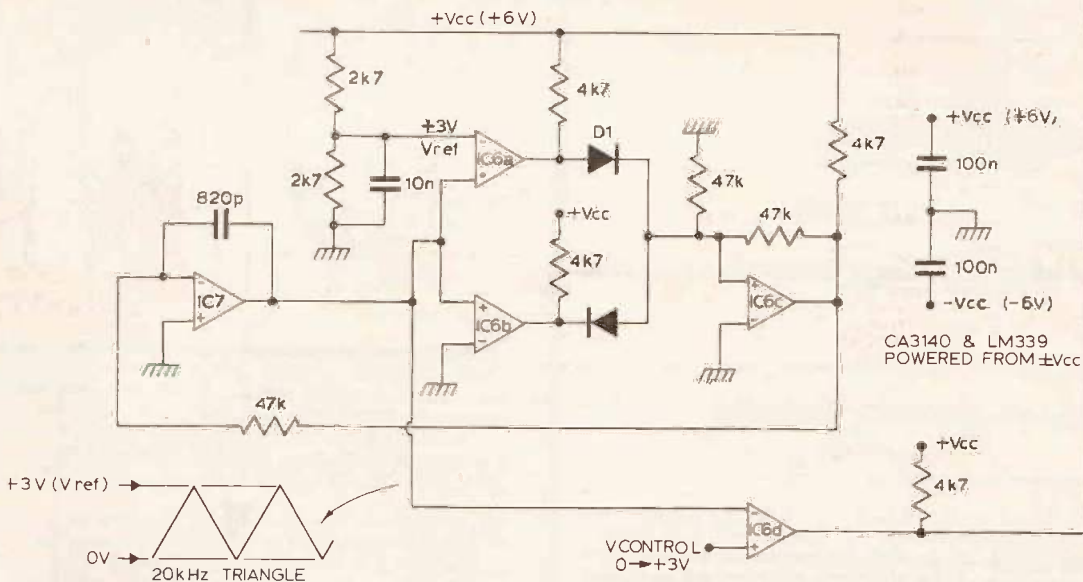
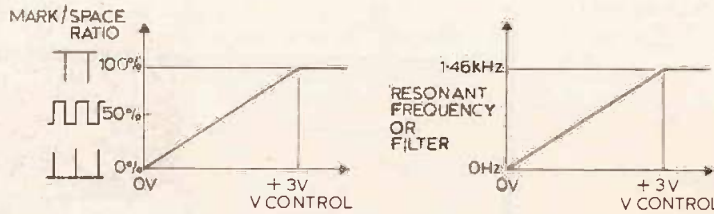
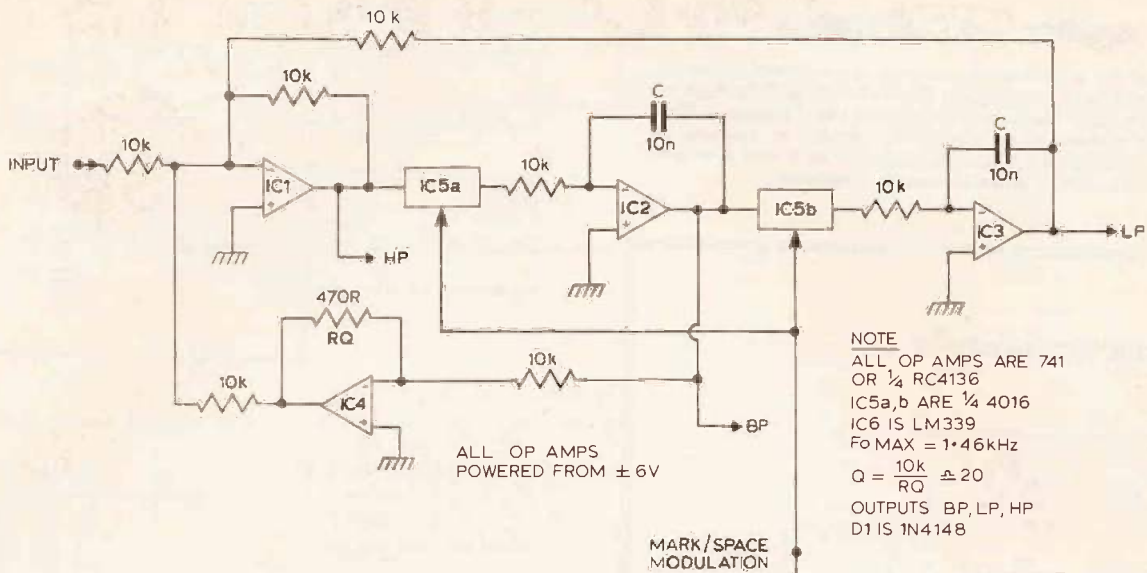

It is possible to change the gain of an amplifier by effectively altering the input resistor. This can be done by markspace modulating a voltage controlled switch in series with the resistor.

When the markspace ratio is low, the switch is OFF most of the time and the effective resistance is large. When the markspace ratio is high the switch is ON most of the time and the effective resistance approaches that of the series resistor.

Having generated a markspace control waveform, it is possible to gang up together literally hundreds of voltage controlled switches. This enables large numbers of variables to be simultaneously changed.

The circuit is a markspace modulated universal filter (IC-6) and the markspace generator itself (IC-11).

IC7-10 forms a triangle square wave oscillator. IC7 is an integrator whose output ramps up and down between 0V and a +3V reference. IC8-10 are all fast comparators. IC8 detects

when the integrator outputs of IC8 & 9 are used to flip over a schmitt trigger IC10, which then drives the integrator. Thus the integrator output ramps up and down between 0V and +3V at a rate of 20 kHz.

It is important that the frequency of the markspace oscillator be relatively high. As a rule of thumb it should be 2 1/2 times the highest frequency components of the signals that you hope to process. The triangle output is fed into IC11's inverting input, the control voltage into the non inverting input. The output of IC11 is the markspace modulation which is used to drive the switches IC5,6. The filter resonant frequency is directly proportional to the mark space ratio that drives these switches.

The number of IC's used is a quad package, and so is the 4016 and so can be the op amps (use RC4136). Thus the whole circuit can be realised with only 4 IC's. Also the mark space oscillator can be used to drive other independent comparators.

15 — 240 Watts!

HY5 Preamplifier

The HY5 is a mono hybrid amplifier ideally suited for all applications. All common input functions (mag Cartridge, tuner, etc.), are catered for internally, the desired function is achieved either by a multi-way switch or direct connection to the appropriate pins. The internal volume and tone circuits merely require connecting to external potentiometers (not included). The HY5 is compatible with all I.L.P. power amplifiers and power supplies. To ease construction and mounting a P.C. connector is supplied with each pre-amplifier.

FEATURES: Complete pre-amplifier in single pack — Multi-function equalization — Low noise — Low distortion — High overload — two simply combined for stereo.

APPLICATIONS: Hi-Fi — Mixers — Disco — Guitar and Organ — Public address

SPECIFICATIONS:

INPUTS: Magnetic Pick-up 3mV Ceramic Pick-up 30mV Tuner 100mV Microphone 10mV Auxiliary 3-100mV; input impedance 47k Ω at 1kHz

OUTPUTS: Tape 100mV; Main output 500mV R.M.S.

ACTIVE TONE CONTROLS: Treble \pm 12dB at 10kHz; Bass \pm at 100Hz

DISTORTION: 0.1% at 1kHz; Signal/Noise Ratio 68dB

OVERLOAD: 38dB on Magnetic Pick-up. **SUPPLY VOLTAGE** \pm 16-50V

Price £6.27 + 78p VAT. P&P free.

HY5 mounting board B1 48p + 6p VAT P&P free.

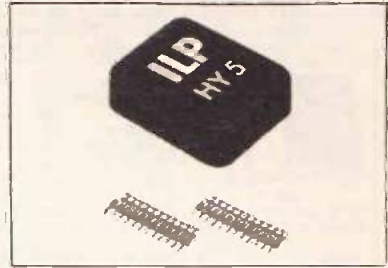

HY30 15 Watts into 8 Ω

The HY30 is an exciting New kit from I.L.P. It features a virtually indestructible I.C. with short circuit and thermal protection. The kit consists of I.C. heatsink, P.C. board, 4 resistors, 6 capacitors, mounting kit, together with easy to follow construction and operating instructions. This amplifier is ideally suited to the beginner in audio who wishes to use the most up-to-date technology available.

FEATURES: Complete kit — Low Distortion — Short, Open and Thermal Protection — Easy to Build

SPECIFICATIONS:

OUTPUT POWER: 15W R.M.S. into 8 Ω ; **DISTORTION:** 0.1% at 15W

INPUT SENSITIVITY: 500mV; **FREQUENCY RESPONSE:** 10Hz-16kHz — 3dB

SUPPLY VOLTAGE: \pm 18V

Price £6.27 + 78p VAT. P&P free.



HY50 25 Watts into 8 Ω

The HY50 leads I.L.P.'s total integration approach to power amplifier design. The amplifier features an integral heatsink together with the simplicity of no external components. During the past three years the amplifier has been refined to the extent that it must be one of the most reliable and robust High Fidelity modules in the World.

FEATURES: Low Distortion — Integral Heatsink — Only five connections — 7 Amp output transistors — No external components

APPLICATIONS: Medium Power Hi-Fi systems — Low power disco — Guitar amplifier

SPECIFICATIONS:

INPUT SENSITIVITY: 500mV

OUTPUT POWER: 25W RMS in 8 Ω ; **LOAD IMPEDANCE:** 4-16 Ω ; **DISTORTION:** 0.04% at 25W at 1kHz

SIGNAL/NOISE RATIO: 75dB; **FREQUENCY RESPONSE:** 10Hz-45kHz — 3dB

SUPPLY VOLTAGE: \pm 25V; **SIZE:** 105.50 x 25mm

Price £8.18 + £1.02 VAT. P&P free.



HY120 60 Watts into 8 Ω

The HY120 is the baby of I.L.P.'s new high power range, designed to meet the most exacting requirements including load line and thermal protection, this amplifier sets a new standard in modular design.

FEATURES: Very low distortion — Integral Heatsink — Load line protection — Thermal protection — Five connections — No external components

APPLICATIONS: Hi-Fi — High quality disco — Public address — Monitor amplifier — Guitar and organ

SPECIFICATIONS:

INPUT SENSITIVITY: 500mV

OUTPUT POWER: 60W RMS into 8 Ω ; **LOAD IMPEDANCE:** 4-16 Ω ; **DISTORTION:** 0.04% at 60W at 1kHz

SIGNAL/NOISE RATIO: 90dB; **FREQUENCY RESPONSE:** 10Hz-45kHz — 3dB

SUPPLY VOLTAGE: \pm 35V

Size: 114 x 50 x 85mm

Price £19.01 + £1.52 VAT. P&P free.

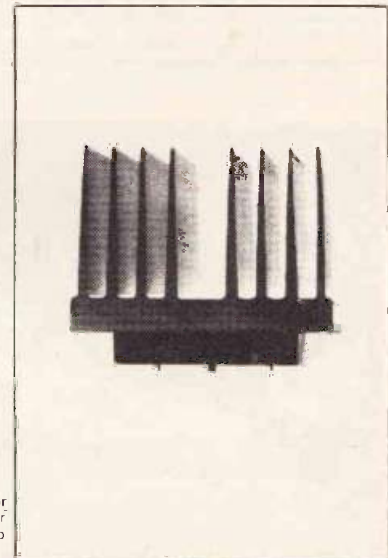

HY200 120 Watts into 8 Ω

The HY200, now improved to give an output of 120 Watts, has been designed to stand the most rugged conditions, such as disco or group while still retaining true Hi-Fi performance.

FEATURES: Thermal shutdown — Very low distortion — Load line protection — Integral Heatsink — No external components

APPLICATIONS: Hi-Fi — Disco — Monitor — Power Slave — Industrial — Public address

SPECIFICATIONS:

INPUT SENSITIVITY: 500mV

OUTPUT POWER: 120W RMS into 8 Ω ; **LOAD IMPEDANCE:** 4-16 Ω ; **DISTORTION:** 0.05% at 100W at 1kHz

SIGNAL/NOISE RATIO: 96dB; **FREQUENCY RESPONSE:** 10Hz-45kHz — 3dB

SUPPLY VOLTAGE: \pm 45V

SIZE: 114 x 100 x 85mm

Price £27.99 + £2.24 VAT. P&P free.

HY400 240 Watts into 4 Ω

The HY400 is I.L.P.'s "Big Daddy" of the range producing 240W into 4 Ω ! It has been designed for high power disco or public address applications. If the amplifier is to be used at continuous high power levels a cooling fan is recommended. The amplifier includes all the qualities of the rest of the family to lead the market as a true high power hi-fidelity power module.

FEATURES: Thermal shutdown — Very low distortion — Load line protection — No external components

APPLICATIONS: Public address — Disco — Power slave — Industrial

SPECIFICATIONS:

OUTPUT POWER: 240W RMS into 4 Ω ; **LOAD IMPEDANCE:** 4-16 Ω ; **DISTORTION:** 0.1% at 240W at 1kHz

SIGNAL/NOISE RATIO: 94dB; **FREQUENCY RESPONSE:** 10Hz-45kHz — 3dB

SUPPLY VOLTAGE: \pm 45V

INPUT SENSITIVITY: 500mV; **SIZE:** 114 x 100 x 85mm

Price £38.61 + £3.09 VAT. P&P free.

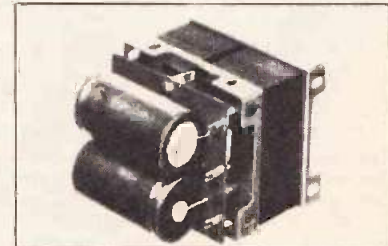

POWER SUPPLIES

PSU36 suitable for two HY30's **£6.44 + 81p VAT**

PSU50 suitable for two HY50's **£8.18 + £1.02 VAT**

PSU70 suitable for two HY120's **£14.58 + £1.17 VAT**

PSU90 suitable for one HY200 **£15.19 + £1.21 VAT**

PSU180 suitable for two HY200's or one HY400 **£25.42 + £2.03 VAT**

TWO YEARS' GUARANTEE ON ALL OF OUR PRODUCTS

I.L.P. Electronics Ltd.
Crossland House
Nackington, Canterbury
Kent CT4 7AD
Tel. (0227) 64723

Please Supply _____
Total Purchase Price _____
I Enclose Cheque Postal Orders Money Order
Please debit my Access account Barclaycard account
Account number _____
Name & Address _____

Signature _____

TRAMPUS

ELECTRONICS LTD.

SEMICONDUCTOR DISTRIBUTORS

ELECTRONIC COMPONENT CENTRE
58-60 GROVE ROAD, WINDSOR, BERKS
SL4 1HS (TRADE AND EXPORT WELCOME)
HOTLINE FOR TELEPHONE CREDIT CARD ORDERS -
WINDSOR 54525



ETI READERS OFFER: OVER £10 DISCOUNT 5% OFF. (THIS MONTH)
QUANTITY DISCOUNT FOR 100 OF ONE TYPE 10% OFF 1 UP PRICE

Cheque or cash orders over £5 Post Free. Other orders add 20p Post & Packing. Credit Card orders £5 min. by post or phone. + Post & Packing 20p. UK add 8% to prices marked. Add 12 1/2% VAT to all other prices. Free price list send S.A.E. All devices to makers specifications. Please quote ETI ad as prices may change. E.&O.E. 1978, Calfax welcome Tue to Sat (Lunch 1-2).



MICRO POWER SUP. PORT

All Int'l spec Grade 1 displays
DL704 CC or DL707 CA 0.3" **E1.25***
FNDS00 CC/161 C 0.8" **E1.25***
MANGA Type/181A 0.5" **E1.25***
DL747 CA or DL 750 CC **E1.69***
Clock IC AY51224 **E1***
LEDS. Bright full spec
0.2" or 0.125" Red 10p
0.2" Dia Red & Chip 12p
0.2" or Green LED **E1***
0.2" or 0.125" Dia All 20p
12 volt Fluorescent Light **E1***
Jackson Tuner 370pl
Trimmer 0.8 or 5 to 40p
Coil Former & Slug 0.3" Dia **E1***
Relay Mini 3 Pole 12 volt
Coil **E1***
RS Type Bleeder 9 to 12v
E1.50*
Date PCB Pen 2 nbs 70p
TUB Ferric CHI. Hkg. **E1***
Decon Board Cleanser Pad **50p***
6x4" Mylen/Copper Board **60p***
Vero Stocked A11 10% off
La. 3 1/4" x 5" x 0.1" Board **56p***

6" x 4" DII Board **E2.25***
PP3 or PP9 Clips. Pair 15p
Dia Plugs. All 19p
Dia Sockets. All 10p
Disc Strobe Tube **E5***

DEVELOPMENT PAR-CELS. All E5 each

SET 1: 250x50 volt Ceramic Capacitors 5%, 10 each
From 22p to 0.10l **E5**
SET 2: Tantalums 1ul to 200ul 20v to 35 volt. Total 50 capacitors **E5**
SET 3: Electrolytic 25 volt 10 each (80) 1/2 5/10/ 47/100/220/1000 **E5**
SET 4: 1/2 watt Resistors 10% CF. 10 each 10 ohm to 5M meg ohm. Total 500. Bulk packed in 1 bag **E5**
SET 5: Zeners 400mw 6 each. 20 values 3 volt to 33 volt (Metal 10) **E5**
SET 6: -100 Presets **E5**
SET 7: Mountains. 10 off. Each T018, T03, T4 (T099) and small T03 **E5***

PASSIVE GEAR

Resistor 1/2 watt 5% CF 2p
Prototype Type PR Vert. 10p
Type 45 Pots Log & Lin 25p
CAPACITORS
Ceramic 50v 5% Hi Stab 22p
to 0.1ul & 22/47 5p
Tantalum Caps 12p
ELECTROLYTICS 25 volt
1/10/47/100ul All 10p
(50 volt 20p) 220 or 470ul **E1***
100ul 25 volt 30p
KNOBS. 1" dia & trim 15p
HEAT SINKS. T05 & 18
10 x NPW Plastic Power 60
volt 2 amp BDBI Type **E1***
TV4 25p*. T03 small 25p*

DISCO TRIAC 10A 400v

8R100 Diac **E1***
C1050 4A 400v SCR **55p***
TAB 1/400 lamp 55p*. 1/600 **65p***

Switches Mini SPST **55p***
Mini DPDT 69p*. Centre off **89p***
Slide Switch **25p***
Push 'On' **35p***

FULL SPEC PAKS ALL E1

Pak A: 12 x Red LEDS **E1***
Pak B: 6 x 741C 8 pin **E1***
Pak C: 4x2 NJ3055. T0 3 **E1***
Pak D: 12 x BC109 **E1***
Pak E: 13 x BC182 **E1***
Pak F: 13 x 2N3704 **E1***
Pak G: 7 x BFY 11 **E1***
Pak H: 7 x 2N3819 etlet **E1***
New Pak I: 10 x Metal Trim, Knob 1/2" dia (syn-thesis etc.) **E1***
Pak J: 6 x 2N3053 **E1***
Pak K: 50x1N4148 **E1***
Pak L: 50 x 33ul 10 volt electrolytic **E1***
Pak M: 4 x Pairs Plastic Power Zamp 60 volt. NPN/PNP BD131/2 Type **E1***
Pak N: 50 x DA81/91 **E1***
Pak P: 20 x Plastic 109 **E1***
Pak Q: 50 x 220ul 6.3v Volt Electrolytic **E1***
Pak R: 14 x BC108 **E1***
Pak S: 14 x BC108 **E1***
Pak T: Top setting **E1***
10 x NPW Plastic Power 60 volt 2 amp BDBI Type **E1***

TRANSISTORS

Look at our Pak T. Ten Plastic Power **E1***
Dr Pak C: 4 x 2N3055 **E1***
Matching 20p*. Ins Kit 10p*

AC127 17p* BFY50 16p*
AC176 10p* BFY51 16p*
AC187 20p* BFX29 28p*
AD161 40p* BSX20 18p*
AF162 40p* MJ2955 **E1***
AF239 42p* MJ3340 44p*
BC107 8p* MJ2955 **E1***
BC108 8p* MJ3055 **80p***
BC109 9p* MPU131 35p
BC109C 15p* ORP12 **55p***
BC147 12p* TIP41A **60p***
BC148 12p* TIP42A **65p***
BC149 12p* TIP2955 **60p***
BC157 15p* TIP3055 **50p***
BC158 15p* T1543 35p
BC159 15p* 2N2648 **39p***
BC167 10p* 2N2905 **22p***
BC168 11p* 2N2926V **10p***
BC169 12p* 2N3053 **16p***
BC177 18p* 2N3055 **45p***
BC178 16p* 2N3614 **E1***
BC179 18p* 2N3702 **9p***
BC182 10p* 2N3704 **9p***
BC183 10p* 2N3706 **9p***
BC184 10p* 2N3819E **18p***
BC212 12p* 2N3820 **38p***
BC213 12p* 2N3904 **15p***
BC214 12p* 2N3906 **15p***
BCV71 20p* 2N4347 **50p***
BD131 37p* 2N5457 **32p***
BD132 37p* 2N5777 **44p***
BD695 69p* TIL31 **E2***
BD696 69p* TIL53 **E1***

DIODES & BRIDGE

1A 50v Bridge **22p***
1N4148 or 1N914 **4p***
DA81 or DA91 **5p***
0A200 & 202 **10p***
1N4001 1A50v **5p***
1N4004 7p*. 1N4007 **15p***

7400N SERIES TTL

ALL FULL SPEC BRANDED

7400 8p* 7475 44p*
7401 9p* 7476 35p*
7402 10p* 7480 39p*
7403 10p* 7481 **E1***
7404 17p* 7482 **E1***
7405 9p* 7483 **E1***
7406 28p* 7485 **E1***
7407 28p* 7486 **35p***
7408 12p* 7490 **36p***
7409 12p* 7491 **75p***
7410 10p* 7492 **35p***
7411 22p* 7493 **35p***
7412 22p* 7494 **75p***
7413 28p* 7495 **75p***
7416 28p* 7496 **85p***
7417 28p* 74100 **E1.15***
7420 10p* 74107 **29p***
7423 26p* 74121 **27p***
7425 26p* 74123 **59p***
7426 26p* 74141 **99p***
7430 10p* 74143 **E3.14***
7432 20p* 74145 **85p***
7440 14p* 74147 **E1.69***
7441 79p* 74152 **E2***
7442 87p* 74154 **E2***
7445 69p* 74155 **80p***
7446 88p* 74156 **80p***
7447 82p* 74157 **E1***
7448 **E1*** 74164 **E1***
7450 15p* 74174 **E1***
7451 15p* 74176 **E1***
7453 15p* 74190 **E2***
7454 15p* 74192 **E2***
7460 15p* 74193 **E2***
7470 29p* 74194 **E2***
7472 26p* 74196 **E1.30***
7473 25p* 74197 **E1***
7474 29p* 74198 **E2***

CMOS TOP VALUE

4000 15p* 4066 58p*
4001 15p* 4067 **E4***
4002 17p* 4069 **22p***
4006 **E1*** 4070 **32p***
4007 18p* 4071 **21p***
4008 92p* 4072 **21p***
4009 58p* 4073 **21p***
4010 58p* 4075 **23p***
4011 15p* 4076 **E1.29***
4012 18p* 4077 **40p***
4013 55p* 4078 **21p***
4016 93p* 4081 **22p***
4016 52p* 4082 **21p***
4017 99p* 4089 **E1.50***
4018 99p* 4093 **85p***
4020 **E1*** 4507 **55p***
4021 **E1*** 4508 **E3***
4022 90p* 4510 **E1.35***
4023 20p* 4511 **E1.68***
4024 76p* 4512 **98p***
4025 19p* 4514 **E2.65***
4027 55p* 4518 **E1.28***
4028 90p* 4518 **E1.05***
4029 **E1*** 4520 **E1.60***
4030 58p* 4521 **E2.68***
4032 **E1*** 4522 **E2***
4034 **E2*** 4528 **99p***
4035 **E1.20*** 4534 **E2.88***
4038 **E1.08*** 4536 **E3.60***
4040 **E1.05*** 4541 **E1.50***
4041 86p* 4543 **E1.75***
4042 81p* 4553 **E4.49***
4043 96p* 4556 **78p***
4045 **E1.30*** 4558 **E1.17***
4046 **E1.30*** 4565 **E1.50***
4047 92p* 4569 **E3.59***
4049 52p* 4583 **E1.10***
4060 **E1.15*** 4585 **E2.05***
4063 **E1.10***



TOP TWOSOME!

555 8 Pin Timer **27p***
741C Full spec DII 8.
Branded Op Amp **19p***

NEW LINEARS Data 10p

TL170 Hall effect **69p***
LD71 Le noise 741 **75p***
TL081 Fet Op. 741 **69p***
TL083 Fet 747 **E1.49***
TL080 Fet 748/308 **E1.15***

IC SUPERMARKET

301 Op Amp **30p***
555 Timer (N555) **27p***
556 Dual 555 **70p***
710 Comparator **40p***
723 Regulator **45p***
741C 8 Pin DII DPA **19p***
741C T099 or DII 14 **39p***
748C Op Amp **33p***
3900 Quad Op Amp **55p***
7805 1 Amp 5 volt **95p***
7805 T03(T09K) **E1***
7806 or 7812 **E1.25***
7815 15 volt plastic **69p***
7900 Negative Series **E2.50***

8038 Sig Generator **E3.55***
76013 & 76023 **E1.35***
CA3130 & CA3140 **94p***
LM380 1 watt Amp **85p***
LM381 Dual Preamp **E1.55***
LM3900 Quad OPA **55p***
MC1160 Decoder **E1***
MC1468 1451 & 1469 **E3***
MC1538 Fet OPA **E4***
N5555 Timer **27p***
N5556 Dual 555 **70p***
TB810 7w AF **E1***
ZM414 Radio **65p***

OIL SOCKETS 8 pin 12p* 28 Pin **E1**
Low 24 Pin 50p* 40 Pin **E1.50**
Profile 14 or 16 Pin 15p*

Build any Project - Fast and Easy

It's the new deal for project builders from Lektrokit! A complete new range of breadboarding and testing devices. At prices anyone can afford. For any project anyone could want to build - from one-chip simplicity to 1,000-chip complexity.

It's fast and easy project building, too. You simply push components in and pull them out. No soldering, no de-soldering, no chance of heat damage. You can make design changes instantly, keeping full leads on components.

In fact, with Lektrokit, you can build a project as fast as you used to sketch a layout. And a lot more easily.

LEKTROKIT completes the circuit

See Lektrokit at one of the Lektrokit dealers near you. There's bound to be one they're springing up everywhere. Send for the name of your nearest - plus FREE full-colour catalogue - to:

Lektrokit Ltd., Dept. ET11 Sutton Industrial Park, Earley, Reading, Berks RG6 1AZ Telephone 0734 669 116



AUDIO OSCILLATOR

WITH LCD DFM OPTION

An audio oscillator combines with a new design in frequency meters that provides accuracy and fast reading rates.

Front view of the audio oscillator. Note that this is an early prototype and the 3V range has been deleted.

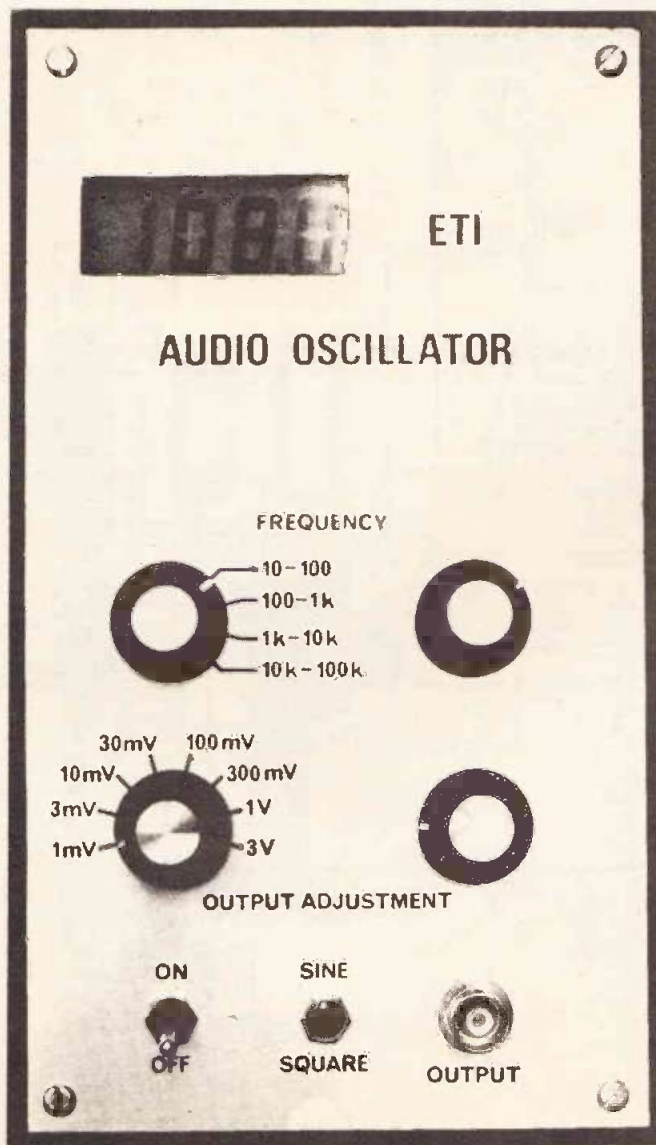

THE WEIN BRIDGE oscillator published in our June issue did not provide a performance of adequate standard for many test applications—one would not have expected so from such a simplified design. Since then we have had many requests to provide a high performance oscillator.

This oscillator started life as another wein bridge, started to evolve as a voltage controlled sweep oscillator but when it became too complex reverted to a simple wein bridge.

One major problem with all home made oscillators is that of scaling the frequency dial. This is not just a problem of positioning the knob but since normally available potentiometers have a tolerance of $\pm 20\%$, the scale length will also vary. In commercial units the use of an expensive wire wound potentiometer solves most of the problems giving reasonably accurate scaling.

We then decided to build in a frequency meter and the high power consumption and the poor resolution, especially at low frequencies, of previous designs led us to develop a completely new design.

This uses what is literally an analogue computer to convert a period measurement into frequency with some digital electronics controlling it and displaying the results. We based this on the Intersil ICL7106 IC which, due to its liquid crystal display drive circuitry, allows a low power consumption design. Due to the method of conversion from period to frequency the range is limited from about 50 to 1999 counts and therefore automatic range selection is used. As the oscillator itself has less range than this, this limitation is no problem.

To simplify wiring we initially used CMOS analogue switches to select the range changing capacitors in the oscillator but this unfortunately increased the second harmonic ▶

LCD FREQUENCY METER

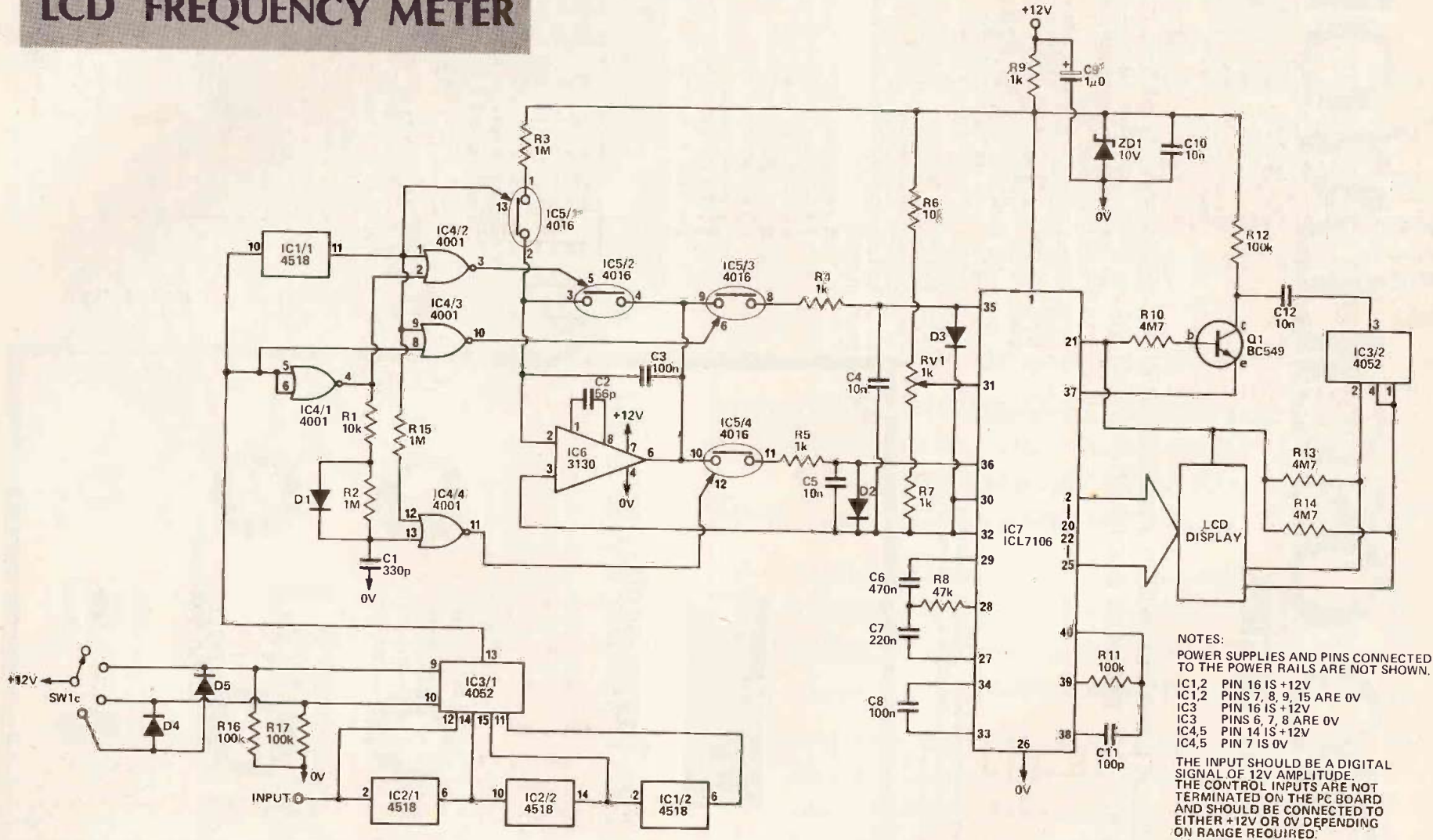
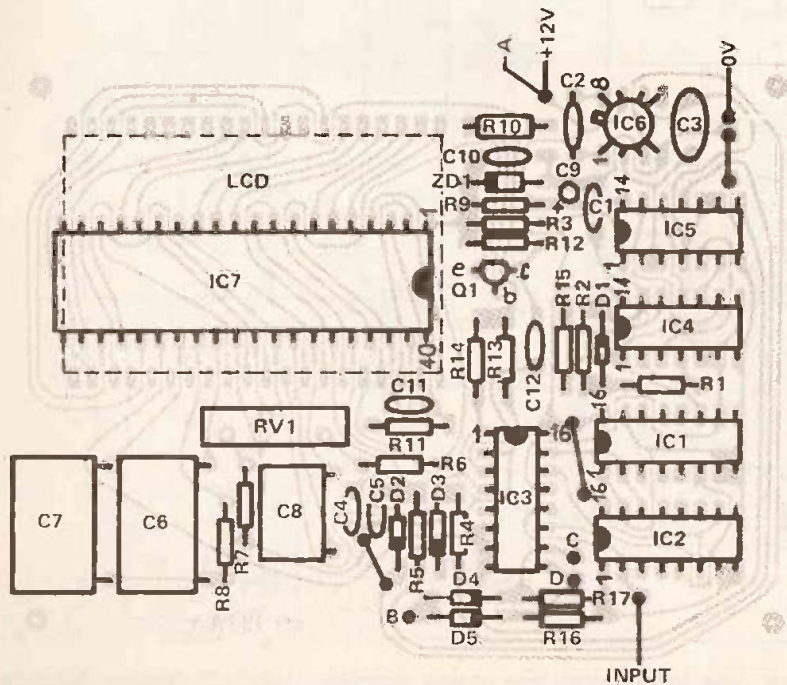
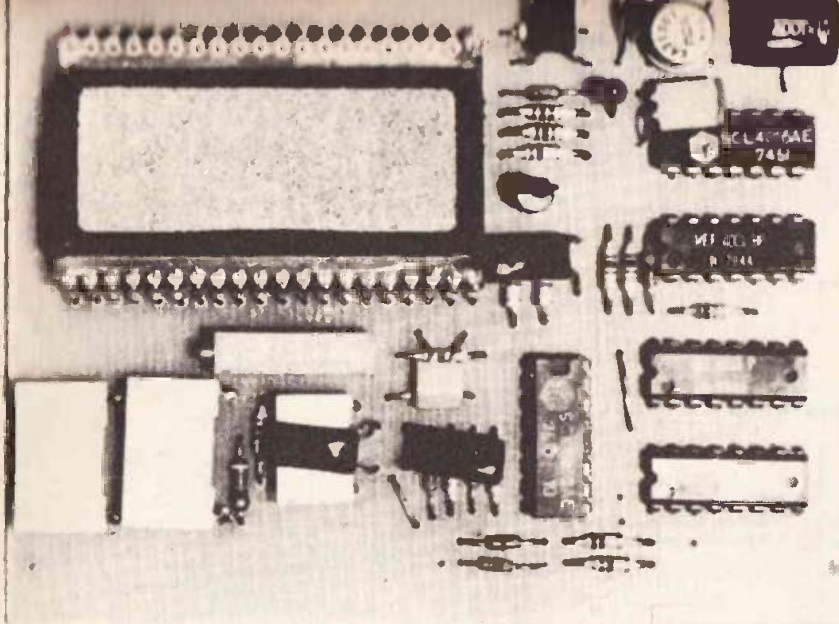

Fig. 1. The circuit diagram of the frequency meter section.

HOW IT WORKS

This section works by generating a voltage proportional to the period of one cycle and using this as the reference voltage for the Intersil voltmeter IC with a fixed voltage on the normal input. This gives the inverse function of normal operation and the display therefore is frequency.

and IC5/2 will turn on. This discharges C3 to zero volts. After a short delay to allow C3 to discharge IC5/4 is turned on transferring that voltage level onto C5. After a total of two cycles the process recommences. The voltage difference between the two capacitors is then displayed on the LCD.



IC5 Operation is as follows. Initially C3 is discharged and for one cycle of the input signal IC5/1 turns on. As the IC7 provides a stable voltage between pin 1 and pin 32 of about 2.8V the output of IC6 will fall linearly with time and as IC5/1 is on for exactly one cycle the voltage change will be proportional to that period.

After IC5/1 turns off the output of IC6 will stay fixed. IC5/3 is then turned on and C4 will change to that voltage. After half a cycle IC5/3 will turn off leaving C4 at that voltage

IC5 are derived from IC1/1 and IC4.

A reference voltage less than half the input voltage will result in the ICL7106 counting past 2000 (over ranging). The two inputs must also lie within the supply rails (less 1.5V). This limits the range of the instrument from 5 Hz to 200 Hz. For the higher frequency ranges, three decade drivers are provided and the necessary output selected by IC3. The correct decimal point is also selected by the other half of this IC.

PARTS LIST

RESISTORS	all 1/4W 5%
R1, 6	10k
R2, 3, 15	1MΩ
R4, 5, 7, 9	1k
R8	47k
R10, 13, 14	4M7
R11, 12, 16, 17	100k

POTENTIOMETER	
RV1	1k ten turn trim

CAPACITORS	
C1	330p ceramic
C2	56p ceramic
C3, 8	100n polyester

C4, 5, 10, 12	10n polyester
C6	470n polyester
C7	220n polyester
C9	1u0 35 V tantalum
C11	100p ceramic

SEMICONDUCTORS	
IC1, 2	4518
IC3	4052
IC4	4001
IC5	4016
IC6	CA3130
IC7	ICL7106
Q1	BC549
D1-D5	1N914
ZD1	10 V 300mW Zener

Shown on this page are the foil pattern, overlay and photograph of the frequency meter section.

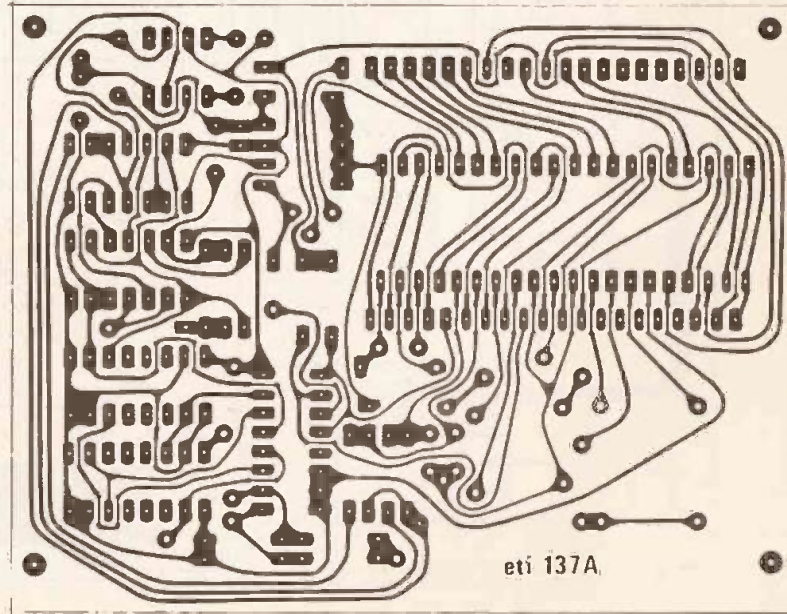

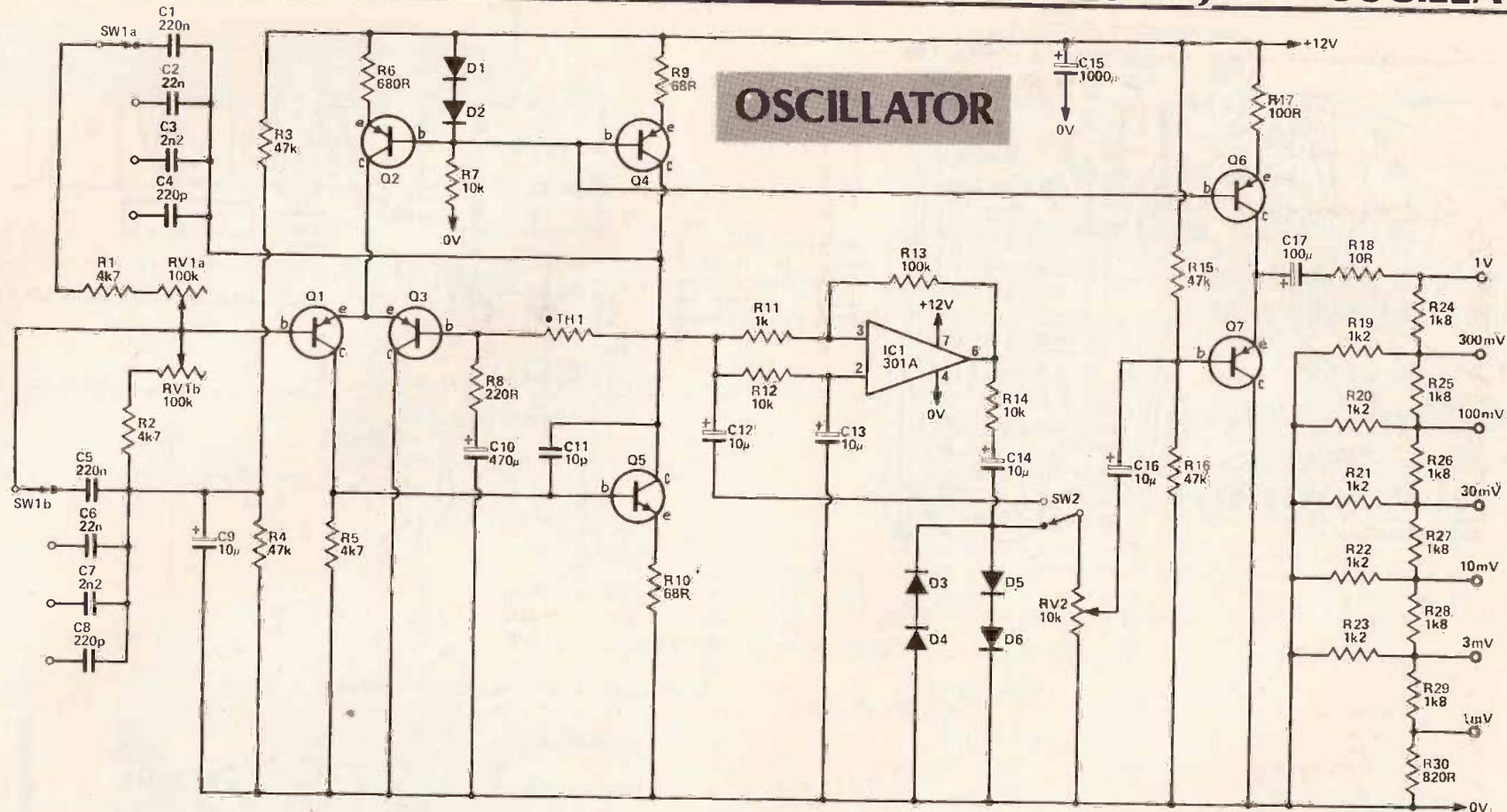

Fig. 2. The circuit diagram of the oscillator section.

PARTS LIST

Oscillator Board

- RESISTORS all 1/2W 5%
- R1, 2, 5 4k7
 - R3, 4, 15, 16 47k
 - R6 680R
 - R7, 12, 14 10k
 - R8 220R
 - R9, 10 68R
 - R11 1k
 - R13 100k
 - R17 100R
 - R18 10R
 - R19 1k2
 - R20 1k2
 - R21 1k2
 - R22 1k2
 - R23 1k2
 - R24 1k8
 - R25 1k8
 - R26 1k8
 - R27 1k8
 - R28 1k8
 - R29 1k8
 - R30 820R

CAPACITORS

- C1, 5 220n polyester
- C2, 6 22n polyester
- C3, 7 2n2 polyester
- C4, 8 220p ceramic
- C9, 12, 13, 14, 15 10µ 25 V electrolytic
- C10 470µ 25 V electrolytic
- C11 10p ceramic
- C15 1000µ 16 V electrolytic
- C17 100µ 25 V electrolytic

SEMICONDUCTORS

- IC1 301A
- Q1-Q5 BC107
- Q6-Q7 BC107
- D1-D2 1N4148
- D3-D6 1N4148
- TH1 100Ω

HOW IT WORKS

The oscillator is of the conventional Wein bridge type with a differential amplifier made up by Q1-Q5. Gain stabilization is provided by the thermistor TH1. This type of circuit oscillates at the frequency where the impedance of the capacitors equals the resistors in the Wein bridge arms. With this feedback network the attenuation does not vary greatly like that of a twin tee but the phase

shift does. The result is a sine wave oscillator with low distortion.

For frequency variation a two gang potentiometer is used to give a 20/1 continuous variation with switched capacitors giving four ranges each a decade apart.

The sine wave output is converted to square wave by IC1 with the amplitude stabilized by D3-D6.

THERMISTOR		SWITCHES	
TH1	type R63	SW1	Three pole four way rotary
POTENTIOMETERS		SW2	SPDT
*RV1	100k dual rotary	MISCELLANEOUS	
RV2	10k lin rotary	PCB	

*RV1 — the preferred curve giving best resolution is antilog. If reverse rotation is acceptable log is as good. Otherwise use a linear curve.

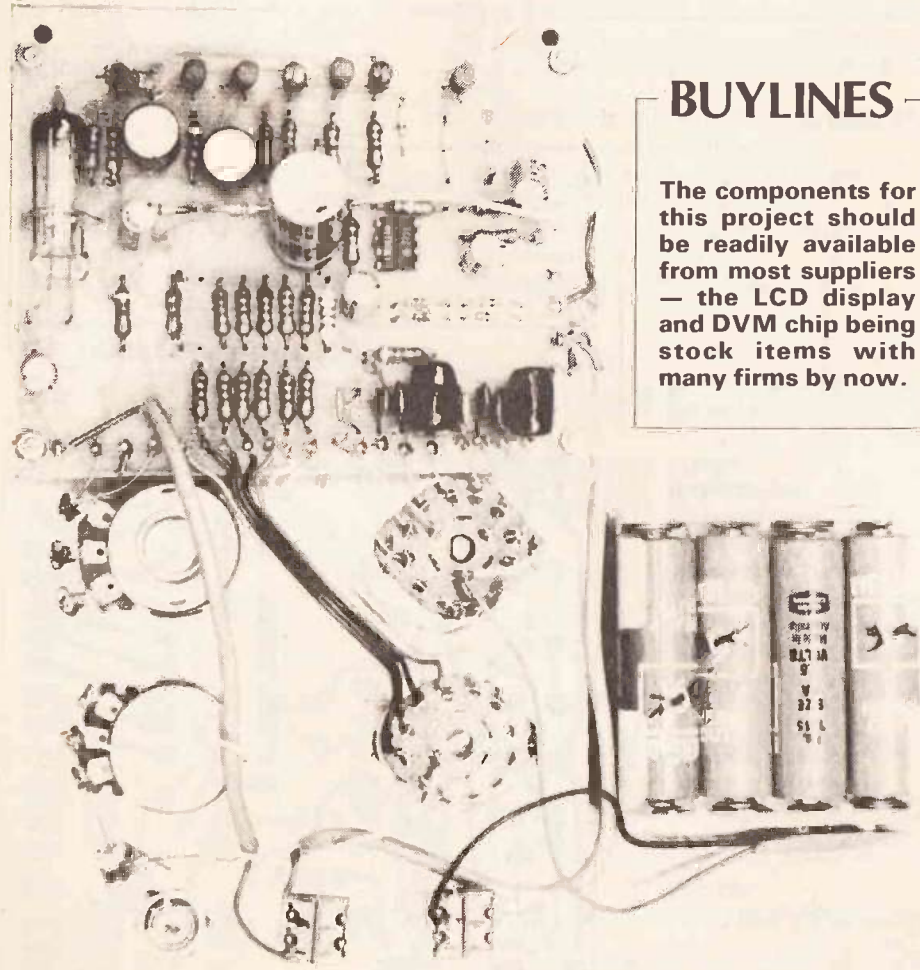

BUYLINES

The components for this project should be readily available from most suppliers — the LCD display and DVM chip being stock items with many firms by now.

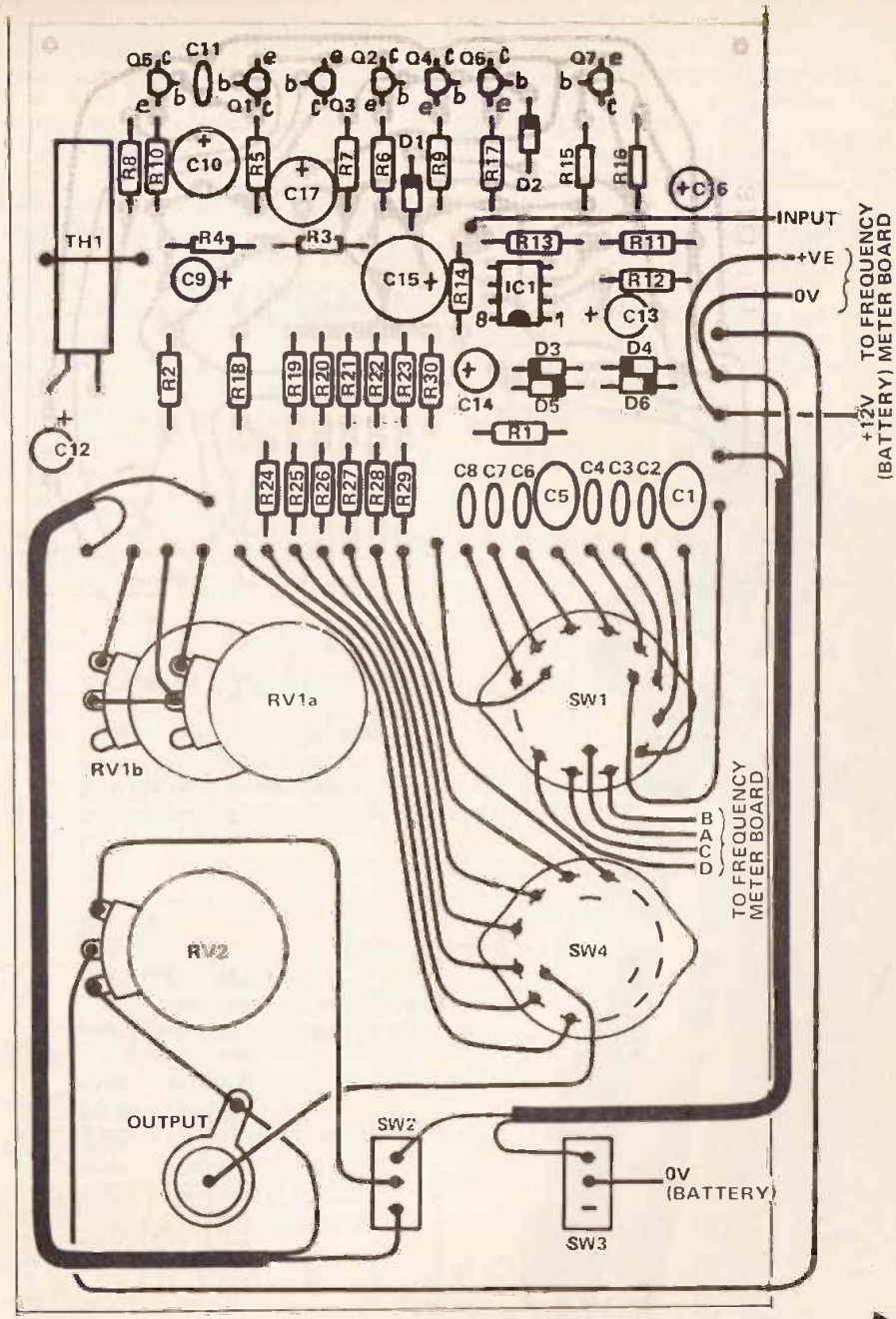

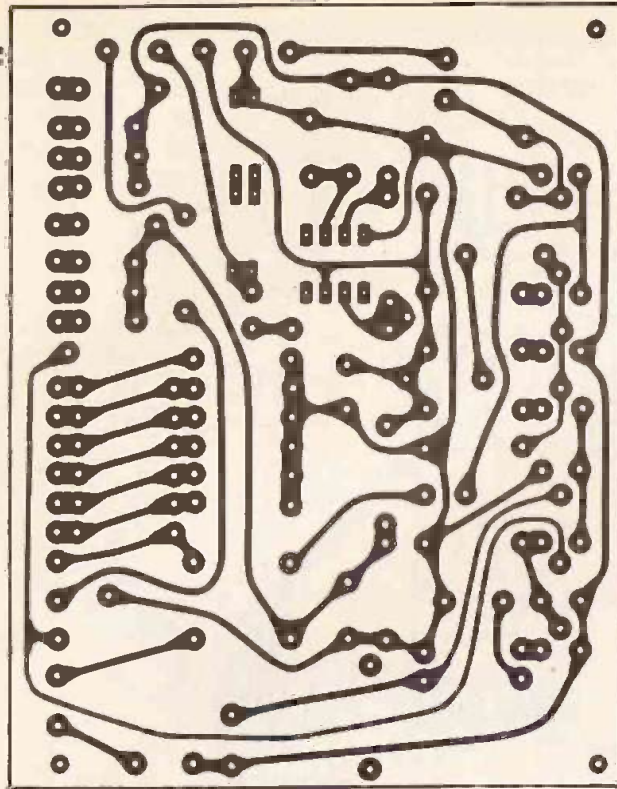

SPECIFICATION

Oscillator Section	
Ranges	10.0—100.0 Hz 100—1 000 Hz 1.00—10.00 kHz 10.0—100.0 kHz
Outputs available	sine or square
Output level	1 V maximum continuously variable plus 10 dB steps down to 1 mV
Output impedance	nominally 600 ohms
Sine wave distortion	< 0.1 %
Square wave risetime	200ns
Frequency Meter Section	
Number of digits	3 1/2
Display	LCD
Reading rate	5 per second
Resolution	0.1 Hz on lowest range
Mode	Period measurement computed to read frequency
General	
Power consumption	26 mA @ 12 V DC

distortion when the supply voltage dropped below 12 volts. This is due to the non-linearity of the "on" resistance when the input voltage changes. We therefore reverted to the good old mechanical switch!

Construction

Assemble the frequency counter board first, following the overlay provided. As this board is mounted very close to the front panel (only the height of the LCD) the capacitors should have leads long enough to allow them to be laid on their side on top of the resistors, etc. Also the CA3130 and the transistor will have to be mounted close to the board. While it is not essential that a socket be used (we didn't) for the LCD, one is recommended. Be very careful

with the display as it is glass and therefore fairly fragile

The oscillator board can now be assembled following its overlay diagram. The thermistor should be tied down using a loop of tinned copper wire and pins should be used on all external wire terminating points. Cut all leads short on the back of the PCBs as the two are mounted back-back with only 6 mm spacing.

We built the units into a large box with all the components mounted on the front panel. The PCBs are secured by four 6BA c/s screws through the aluminium but hidden by the front panel. The frequency meter board is spaced using 6BA nuts to give just enough clearance for the display and is held in place using 6.4 mm long tapped spacers. Check that the spacers do not touch any track on

the PCB and if so add pieces of insulation material under them.

The switches and potentiometers can now be mounted on the front panel and the wiring from the frequency counter board to the range switch done. Add wires from the two power connections and the input for later connections to the oscillator board.

The oscillator board can now be mounted onto the back of the frequency meter board ensuring that no leads short between the two boards. Also check that the spacers do not touch any tracks on the oscillator board. The wiring of the front panel can now be completed.

Checking and Adjustment

Switch on the check that the frequency meter and oscillator are

working. Monitor the output of the oscillator with an accurate frequency counter and adjust the oscillator to the top end of one range. The frequency meter can now be calibrated by means of the 10 turn potentiometer on that board.

Check that the display range changes correctly and that the decimal point also moves. Each range while nominally having a 10-100 variation will be adjustable from about 7 to 150. Check the attenuator has 10 dB between steps.

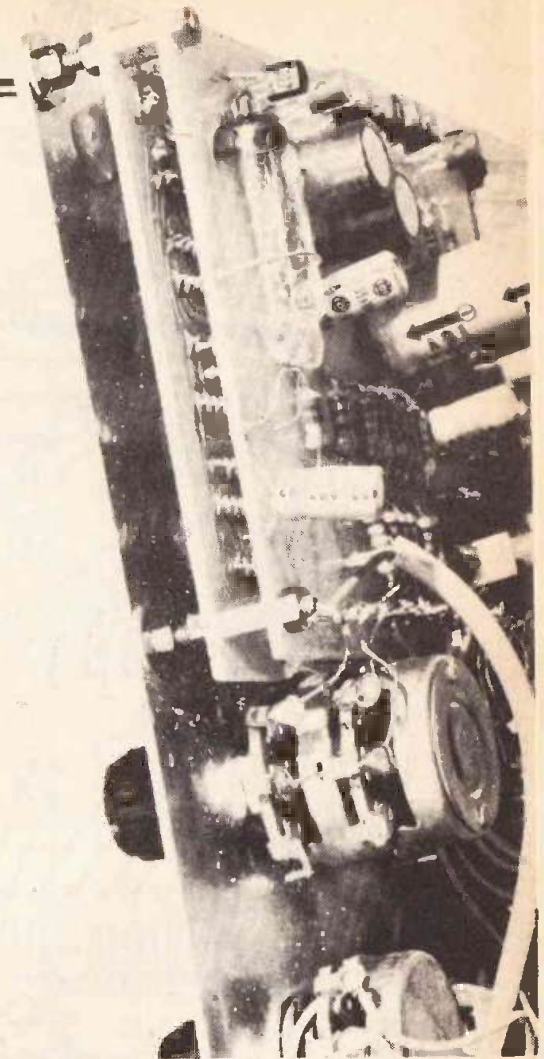

Marshall's

Come and get a great deal

Call in and see us 9-5.30 Mon-Fri 9-5.00 Sat
Express Mail Order Tel. orders on credit cards £10 min.
Trade and export enquiries welcome

A. Marshall (London) Ltd., Dept. ETI, Head Office mail order; Kingsgate House, Kingsgate Place, NW6 4TA. Tel. 01-624 0805 Retail Sales London: 40-42 Cricklewood Broadway, NW2 3ET. Tel. 01-452 0161/2 Telex 21492 London: 325 Edgware Road, W2. Tel. 01-723 4242 Glasgow: 85 West Regent Street, G2 2OD. Tel. 041-332 4133 Bristol: 1 Straits Parade, Fishponds Road, BS16 2LX. Tel. 0272 654201.

TRANSISTORS

2N496	0.39	2N2218	0.35	2N393	0.17	2N403	0.60	2N5192	0.80	2N6124	0.45	BC108A	0.16	BC1188	0.35	BC123L	0.17	BC1338	0.23	BD240A	0.49	BF160	0.33	BF179	0.30	ME4001	0.16	TP3003	0.70
2N497	0.31	2N2218A	0.38	2N396	0.19	2N4059	0.17	2N5194	0.80	2N6125	0.75	BC108B	0.17	BC119A	0.25	BC123LA	0.17	BC1339	0.23	BD240C	0.59	BF161	0.65	BF180	0.30	ME4002	0.16	TP31A	0.54
2N498	0.49	2N2219	0.38	2N396	0.19	2N4060	0.22	2N5195	0.80	2N6126	0.55	BC109	0.16	BC119B	0.25	BC123LB	0.17	BC1340	0.23	BD241A	0.49	BF172	0.37	BF229	0.34	ME4101	0.11	TP32A	0.59
2N499	0.58	2N2219A	0.39	2N397	0.19	2N4061	0.19	2N5245	0.37	2N6127	0.45	BC109A	0.17	BC119C	0.26	BC123LC	0.17	BC1341	0.23	BD242A	0.55	BF177	0.27	BF330	0.34	ME4102	0.11	TP32C	0.76
2N500	0.30	2N2220	0.39	2N398	0.85	2N4062	0.29	2N5246	0.38	2N6128	0.48	BC109B	0.18	BC119D	0.26	BC123LD	0.17	BC1342	0.23	BD243A	0.62	BF178	0.27	BF340	0.34	ME4103	0.11	TP41A	0.72
2N501	0.30	2N2221	0.25	2N399	0.75	2N4063	1.35	2N5247	0.44	2N6129	0.82	BC110	0.30	BC119E	0.13	BC123LE	0.17	BC1343	0.23	BD244A	0.70	BF179	0.33	BF350	0.38	ME4104	0.11	TP41C	0.97
2N502	0.30	2N2222	0.25	2N400	1.45	2N4121	0.27	2N5248	0.44	2N6130	3.10	BC111	0.18	BC119F	0.15	BC123LF	0.18	BC1344	0.23	BD245A	0.87	BF180	0.37	BF360	0.30	ME4105	0.22	TP42A	0.86
2N503	0.30	2N2223	0.25	2N401	1.45	2N4122	0.27	2N5249	0.44	2N6131	0.82	BC112	0.18	BC119G	0.15	BC123LF	0.18	BC1345	0.23	BD246A	0.87	BF181	0.37	BF370	0.35	ME5102	0.22	TP42C	1.08
2N504	0.30	2N2224	0.25	2N402	1.45	2N4123	0.27	2N5250	0.44	2N6132	0.82	BC113	0.18	BC119H	0.15	BC123LF	0.18	BC1346	0.23	BD247A	0.87	BF182	0.37	BF380	0.30	ME5255	0.35	TP395	0.70
2N505	0.30	2N2225	0.25	2N403	1.45	2N4124	0.27	2N5251	0.44	2N6133	0.82	BC114	0.18	BC119I	0.15	BC123LF	0.18	BC1347	0.23	BD248A	0.87	BF183	0.37	BF390	0.30	ME5302	0.22	TP43A	0.86
2N506	0.30	2N2226	0.25	2N404	1.45	2N4125	0.27	2N5252	0.44	2N6134	0.82	BC115	0.18	BC119J	0.15	BC123LF	0.18	BC1348	0.23	BD249A	0.87	BF184	0.37	BF400	0.30	ME5402	0.22	TP44A	0.86
2N507	0.30	2N2227	0.25	2N405	1.45	2N4126	0.27	2N5253	0.44	2N6135	0.82	BC116	0.18	BC119K	0.15	BC123LF	0.18	BC1349	0.23	BD250A	0.87	BF185	0.37	BF410	0.30	ME5502	0.22	TP45A	0.86
2N508	0.30	2N2228	0.25	2N406	1.45	2N4127	0.27	2N5254	0.44	2N6136	0.82	BC117	0.18	BC119L	0.15	BC123LF	0.18	BC1350	0.23	BD251A	0.87	BF186	0.37	BF420	0.30	ME5602	0.22	TP46A	0.86
2N509	0.30	2N2229	0.25	2N407	1.45	2N4128	0.27	2N5255	0.44	2N6137	0.82	BC118	0.18	BC119M	0.15	BC123LF	0.18	BC1351	0.23	BD252A	0.87	BF187	0.37	BF430	0.30	ME5702	0.22	TP47A	0.86
2N510	0.30	2N2230	0.25	2N408	1.45	2N4129	0.27	2N5256	0.44	2N6138	0.82	BC119	0.18	BC119N	0.15	BC123LF	0.18	BC1352	0.23	BD253A	0.87	BF188	0.37	BF440	0.30	ME5802	0.22	TP48A	0.86
2N511	0.30	2N2231	0.25	2N409	1.45	2N4130	0.27	2N5257	0.44	2N6139	0.82	BC120	0.18	BC119O	0.15	BC123LF	0.18	BC1353	0.23	BD254A	0.87	BF189	0.37	BF450	0.30	ME5902	0.22	TP49A	0.86
2N512	0.30	2N2232	0.25	2N410	1.45	2N4131	0.27	2N5258	0.44	2N6140	0.82	BC121	0.18	BC119P	0.15	BC123LF	0.18	BC1354	0.23	BD255A	0.87	BF190	0.37	BF460	0.30	ME6002	0.22	TP50A	0.86
2N513	0.30	2N2233	0.25	2N411	1.45	2N4132	0.27	2N5259	0.44	2N6141	0.82	BC122	0.18	BC119Q	0.15	BC123LF	0.18	BC1355	0.23	BD256A	0.87	BF191	0.37	BF470	0.30	ME6102	0.22	TP51A	0.86
2N514	0.30	2N2234	0.25	2N412	1.45	2N4133	0.27	2N5260	0.44	2N6142	0.82	BC123	0.18	BC119R	0.15	BC123LF	0.18	BC1356	0.23	BD257A	0.87	BF192	0.37	BF480	0.30	ME6202	0.22	TP52A	0.86
2N515	0.30	2N2235	0.25	2N413	1.45	2N4134	0.27	2N5261	0.44	2N6143	0.82	BC124	0.18	BC119S	0.15	BC123LF	0.18	BC1357	0.23	BD258A	0.87	BF193	0.37	BF490	0.30	ME6302	0.22	TP53A	0.86
2N516	0.30	2N2236	0.25	2N414	1.45	2N4135	0.27	2N5262	0.44	2N6144	0.82	BC125	0.18	BC119T	0.15	BC123LF	0.18	BC1358	0.23	BD259A	0.87	BF194	0.37	BF500	0.30	ME6402	0.22	TP54A	0.86
2N517	0.30	2N2237	0.25	2N415	1.45	2N4136	0.27	2N5263	0.44	2N6145	0.82	BC126	0.18	BC119U	0.15	BC123LF	0.18	BC1359	0.23	BD260A	0.87	BF195	0.37	BF510	0.30	ME6502	0.22	TP55A	0.86
2N518	0.30	2N2238	0.25	2N416	1.45	2N4137	0.27	2N5264	0.44	2N6146	0.82	BC127	0.18	BC119V	0.15	BC123LF	0.18	BC1360	0.23	BD261A	0.87	BF196	0.37	BF520	0.30	ME6602	0.22	TP56A	0.86
2N519	0.30	2N2239	0.25	2N417	1.45	2N4138	0.27	2N5265	0.44	2N6147	0.82	BC128	0.18	BC119W	0.15	BC123LF	0.18	BC1361	0.23	BD262A	0.87	BF197	0.37	BF530	0.30	ME6702	0.22	TP57A	0.86
2N520	0.30	2N2240	0.25	2N418	1.45	2N4139	0.27	2N5266	0.44	2N6148	0.82	BC129	0.18	BC119X	0.15	BC123LF	0.18	BC1362	0.23	BD263A	0.87	BF198	0.37	BF540	0.30	ME6802	0.22	TP58A	0.86
2N521	0.30	2N2241	0.25	2N419	1.45	2N4140	0.27	2N5267	0.44	2N6149	0.82	BC130	0.18	BC119Y	0.15	BC123LF	0.18	BC1363	0.23	BD264A	0.87	BF199	0.37	BF550	0.30	ME6902	0.22	TP59A	0.86
2N522	0.30	2N2242	0.25	2N420	1.45	2N4141	0.27	2N5268	0.44	2N6150	0.82	BC131	0.18	BC119Z	0.15	BC123LF	0.18	BC1364	0.23	BD265A	0.87	BF200	0.37	BF560	0.30	ME7002	0.22	TP60A	0.86
2N523	0.30	2N2243	0.25	2N421	1.45	2N4142	0.27	2N5269	0.44	2N6151	0.82	BC132	0.18	BC119AA	0.15	BC123LF	0.18	BC1365	0.23	BD266A	0.87	BF201	0.37	BF570	0.30	ME7102	0.22	TP61A	0.86
2N524	0.30	2N2244	0.25	2N422	1.45	2N4143	0.27	2N5270	0.44	2N6152	0.82	BC133	0.18	BC119AB	0.15	BC123LF	0.18	BC1366	0.23	BD267A	0.87	BF202	0.37	BF580	0.30	ME7202	0.22	TP62A	0.86
2N525	0.30	2N2245	0.25	2N423	1.45	2N4144	0.27	2N5271	0.44	2N6153	0.82	BC134	0.18	BC119AC	0.15	BC123LF	0.18	BC1367	0.23	BD268A	0.87	BF203	0.37	BF590	0.30	ME7302	0.22	TP63A	0.86
2N526	0.30	2N2246	0.25	2N424	1.45	2N4145	0.27	2N5272	0.44	2N6154	0.82	BC135	0.18	BC119AD	0.15	BC123LF	0.18	BC1368	0.23	BD269A	0.87	BF204	0.37	BF600	0.30	ME7402	0.22	TP64A	0.86
2N527	0.30	2N2247	0.25	2N425	1.45	2N4146	0.27	2N5273	0.44	2N6155	0.82	BC136	0.18	BC119AE	0.15	BC123LF	0.18	BC1369	0.23	BD270A	0.87	BF205	0.37	BF610	0.30	ME7502	0.22	TP65A	0.86
2N528	0.30	2N2248	0.25	2N426	1.45	2N4147	0.27	2N5274	0.44	2N6156	0.82	BC137	0.18	BC119AF	0.15	BC123LF	0.18	BC1370	0.23	BD271A	0.87	BF206	0.37	BF620	0.30	ME7602	0.22	TP66A	0.86
2N529	0.30	2N2249	0.25	2N427	1.45	2N4148	0.27	2N5275	0.44	2N6157	0.82	BC138	0.18	BC119AG	0.15	BC123LF	0.18	BC1371	0.23	BD272A	0.87	BF207	0.37	BF630	0.30	ME7702	0.22	TP67A	0.86
2N530	0.30	2N2250	0.25	2N428	1.45	2N4149	0.27	2N5276	0.44	2N6158	0.82	BC139	0.18	BC119AH	0.15	BC123LF	0.18	BC1372	0.23	BD273A	0.87	BF208	0.37	BF640	0.30	ME7802	0.22	TP68A	0.86
2N531	0.30	2N2251	0.25	2N429	1.45	2N4150	0.27	2N5277	0.44	2N6159	0.82	BC140	0.18	BC119AI	0.15	BC123LF	0.18	BC1373	0.23	BD274A	0.87	BF209	0.37	BF650	0.30	ME7902	0.22	TP69A	0.86
2N532	0.30	2N2252	0.25	2N430	1.45	2N4151	0.27	2N5278	0.44	2N6160	0.82	BC141	0.18	BC119AJ	0.15	BC123LF	0.18	BC1374	0.23	BD275A	0.87	BF210	0.37	BF660	0.30	ME8002	0.22	TP70A	0.86
2N533	0.30	2N2253	0.25	2N431	1.45	2N4152	0.27	2N5279	0.44	2N6161	0.82	BC142	0.18	BC119AK	0.15	BC123LF	0.18	BC1375	0.23	BD276A	0.87	BF211	0.37	BF670	0.30	ME8102	0.22	TP71A	0.86
2N534	0.30	2N2254	0.25	2N432	1.45	2N4153	0.27	2N5280	0.44	2N6162	0.82	BC143	0.18	BC119AL	0.15	BC123LF	0.18	BC1376	0.23	BD277A	0.87	BF212	0.37	BF680	0.30	ME8202	0.22	TP72A	0.86
2N535	0.30	2N2255	0.25	2N433	1.45	2N4154	0.27	2N5281	0.44	2N6163	0.82	BC144	0.18	BC119AM	0.15	BC123LF	0.18	BC1377	0.23	BD278A	0.87	BF213	0.37	BF690	0.30	ME8302	0.22	TP73A	0.86
2N536	0.30	2N2256	0.25	2N434	1.45	2N4155	0.27	2N5282	0.44	2N6164	0.82	BC145	0.18	BC119AN	0.15	BC123LF	0.18	BC1378	0.23	BD279A	0.87	BF214	0.37	BF700	0.30	ME8402	0.22	TP74A	0.86
2N537	0.30	2N2257	0.25	2N435																									

BUILD-IT-YOURSELF NEW! TEST GEAR KIT

BASIC SERVICING
INSTRUMENTS WITH
EASY STAGE BY STAGE BUILDING
INSTRUCTIONS - IDEAL FOR THE AMATEUR

MULTI RANGE TEST METER

A general purpose meter covering all usual ranges of A.C. and D.C. volts current and resistance measurements

AUDIO SIGNAL GENERATOR

New design covering 10Hz to 10KHz and variable output. Distortion less than 0.01% Ideal for HI-FI Testing.

OSCILLOSCOPE

A basic 3" general purpose cathode ray oscilloscope for simple testing and servicing work. Sensitivity 0.3 volts/cm

SEND NOW FOR FREE DETAILS

To LERNAKITS, P.O. Box 156, Jersey.

Name _____

Address _____

NO DISCO SYSTEM IS COMPLETE WITHOUT...

ROPELIGHTS Rope light kits now available from Roger Squire's — 22 feet long 4 channel, including Tube Bulbs and Multiple connectors. These ropelights are demonstration stock and will require some bulb replacement — we will supply 20 spare bulbs free with your kit. Additional sets of 20 bulbs cost £4.88 each

PIEZO HORNS FANTASTIC SPECIAL OFFER TO READERS OF ELECTRONICS TODAY
Tweeters for your disco, PA system or Hi-Fi. Frequency range 5K-20K No X over required. They can be used in any PA system up to 100W. Why pay more?
OUR PRICE ONLY **£4.99** each (P&P 35p each)

BULGIN OCTAL PLUGS AND SOCKETS
There's always hundreds of Bulgin Octal multiway plugs and sockets in stock at Roger Squire's. Each pin rated 6A. Perfect for your Sound to Light System. P552 SOCKET
£0.65 (P&P 35p) P551 PLUG **£1.84** (P&P 35p)
Carriage on 10 or more nominal £1.00. Also available. 6-way multicore cable (6 Amps per core) as stock £0.65 per metre. Please phone for carriage quote

PROJECTORS SQUIRE MULTIFECT 150 including rotator and effects wheel. A truly versatile projector which uses a powerful 150W Tungsten bulb, all effects attachments simply slot in ready for use
A BARGAIN AT **£40.50** (P&P £1.00)

SOLAR 250 Utilising a 250W Quartz-iodine bulb giving brilliant light output this projector is fan-cooled and can be used free standing or ceiling mounted. Dual effect system for stunning versatility. Rotators are extra. Huge choice of special effects and attachments!
NOW ONLY £70.20 (P&P £2.00)
Plus sockets, Fuses, Plugs, etc etc

PLUS MANY DISCO ACCESSORIES
All Roger Squire's shops have a service department which carries large stocks of DISCO SPARES & ACCESSORIES. For example: Fans and H. Disco Speakers 12" and 15" BSR and Garrard decks at discount prices

Roger Squire's DISCO GEAR

Send Mail Orders to: Roger Squire's Mail Orders, Barnet Trading Estate, Park Road, Barnet, Herts EN5 5SA 01-441 3527 (Hotline) 01-441 1919 (Switchboard) Open Mon-Fri, 9.5-3.0
Personal callers: ROGER SQUIRE'S DISCO CENTRES
LONDON: 176 Junction Road, Tufnell Park, N19 5QQ. 01-272 7474
BRISTOL: 125 Church Road, Redfield, Bristol BS5 9JR. 0272 550550
MANCHESTER: 251 Deansgate, Manchester M3 4EN. 061-831 7676
Open from 10-5 Tues-Sat 10-8 Weds Closed Mondays

MAINS OPERATED ELECTRONIC DIGITAL ALARM CLOCK

- ETI RECOMMEND THIS MODEL**
- Hanimex HC-1100
 - Large Bright LED display
 - White case with red display on black background
 - Adjustable dim / bright control
 - Silent operation, all electronic
 - Space age technology L.S.I. circuitry
 - Alarm and 9 minute snooze repeater
 - P.M. indicator
 - Seconds Display
 - Size 100mm x 130mm x 60mm high
 - Fully guaranteed



HENRY'S RADIO
404 Edgware Rd. London W2
PHONE (01)723-1008

THIS MONTH'S SPECIAL OFFER "Motorola Audio Amplifier 1watt I.C."

- 1 watt plus into 8-16 Ω. 9-16V. 10-400 MV sensitivity. Short circuit proof, no heatsink required. **Only 90p** with Data and circuits.
- Sentinel Smoke and Gas Detector.** This beautifully made unit uses quality components on fibre-glass board, encased in heavy duty, domed diecast box, 3 1/2" diam. x 1 1/2" high. LED. Indicator TGS105 plug in sensor, 24v, or 12v by altering 3 resistors. Will drive relay or lamp. Ideal for caravans, boats, kitchens, etc. etc. £6.45 with circuit and data.
- Miniature **Vemtron™ FM4 10.7MHz** ceramic filters 50p each, 3 for £1
- Crystal earpieces** with lead 40p each, 3 for £1
- Magnetic earpieces** with lead and plug 25p each 8 for £1
- Ultrasonic transducers** transmitter and receiver. 14mm diam 40 kcs. £4.25 per pair
- 4 aluminium boxes 128 x 44 x 38mm, ideal for signal injectors, etc. £1.00
- 100 miniature reed switches**, ideal for burglar alarms, model railways, etc. £3.30
- 6.6-pole 12 volt reed relays** on board P245
- High quality computer panels**, smothered in top-grade components.
- 5lbs £4.75
10lbs £8.95
- New U.H.F. transistor TV tuners**, Rotary type with slow motion drive, aerial socket and leads. £2.50
- Aluminium TV coax plus -10 for £1
- Miniature edgewise panel mounting level meters** 200µ F.S.D. 90p
- 300 mixed resistors 1/2 & 1/4 watt £1.50
- 300 modern mixed caps most types £3.30
- 100 mixed electrolytics £2.20
- 300 mixed printed circuit components £1.50
- 300 mixed printed circuit resistors £1.00
- 100 high-wattage resistors W.W., etc. £2.20
- 20 assorted VDRs and thermistors £1.20
- 25 assorted presets, skeleton etc £1.20
- 25 assorted pots and presets £1.50
- 470 µ F 25v radial, modern type 10 for £1
- 150 mixed 1- and 2-watt resistors £1.50
- 100k varicap pots**, can be banked side by side, very compact 10 for £1
- Mains Neons**, long leads 15 for £1
- 100 mixed modern miniature ceramic and plate caps £1.20
- Don't let your environment dehydrate you. BUY OUR "HONEYWELL HUMIDITY CONTROLLER"**. Membrane actuated, adjustable by 1/4 shaft ideal for greenhouses, offices, centrally heated homes etc. 3.75A contacts at 250V. Build Humidifiers or dehydration alarms with this novel gadget at a fraction of original cost. £1 each, 3 for £2.50.
- Semiconductor Bargains**
- New Super Bargain Diode Pack.** Includes zener, power, bridge, varicap, silicon, germanium, marked, unmarked, etc. Excellent value. 300 for £2.95
- New Improved Transistor Packs: 100** New and marked transistors including BC 148, BC 154, BF 274, BC 212L, BF 200 and lots of others. **only £4.95.**
- 200 transistors** as above and including 2N3055, AC128, BD131, BFY50, **only £9.95.**
- ITT 25kV ctv eht modules for Dacca, Bradford, chassis brand new £2.50, 5 for £10
- BD131 3 for £1.00
- SN76115N (equivalent MC 1310) 50p
- TBA 120A 50p
- 10 assorted convergence pots £1.00
- 12 Quil, low profile 14 pin I.C. sockets £1.00
- BF 200 6 - £1 BF 274 12 - £1
BC 212L 10 - £1 BC 148 12 - £1
BC 154 12 - £1 Varicap diodes 20 for £1 (B.B. types)
- Deluxe Fibre Glass Printed Circuit Etching Kits**
includes 150 sq ins copper clad 1/8" board
1lb. ferric chloride, 1 dialo etch resist pen,
abrasive cleaner, 2 micr drill bits, etch tray
and instructions **Only £5.35**
- 150 sq ins fibre glass board £2.00
- Dalo pen 90p
- 1lb. ferric chloride to mil spec £1.25
- 5lbs. ferric chloride to mil spec £5.00
- Instruction sheet 20p
- 30p P&P ON ALL ABOVE ITEMS. SEND CHEQUE OR POSTAL ORDER WITH ORDER TO SENTINEL SUPPLY DEPT. ETI, 149A BROOKMILL ROAD, DEPTFORD LONDON SE8**
- Callers by appointment only

INSIDE ULTRASONICS

Ultrasonic sound at very high frequencies is being used increasingly for medical diagnosis. Dr P. N. T. Wells of Bristol General Hospital reports.

THE IMPORTANCE OF ultrasonic diagnostic methods lies in the fundamental differences between them and other techniques such as radiology and radioisotope scanning. The symptoms of some diseases, and of natural conditions such as pregnancy, are best investigated by ultrasound. It maps out anatomical cross-sections, measures the performance of the heart and the flow of blood, and identifies many kinds of abnormality, including several types of cancer, all without encroaching into the body in any way.

Twenty-five years ago, doctors seeking to investigate the structures of the body had no alternative to X-rays and this often involved injections of substances to give better contrast to obtain information about soft tissues. Nowadays, ultrasonic methods have replaced radiology in helping to solve a number of clinical problems. Doctors depend on ultrasonic diagnosis, and patients demand this kind of investigation. The procedures are rapid and painless and nothing enters the body other than ultrasound waves. Unlike ionizing radiations, ultrasound at diagnostic exposure levels seems to be harmless.

Basic Principles

Most diagnostic applications of ultrasound depend on the reflection of ultrasonic waves at surfaces between tissue structures which differ in their so-called characteristic impedance. The characteristic impedance of a material is equal to the product of its density and the velocity of ultrasound within it. The densities of soft tissues, about 10^3 kg m^{-3} (kilograms per cubic metre), and the velocities of ultrasound within them, about 1500 m s^{-1} (metres per second), are similar to those for water. When an ultrasonic wave strikes the boundary between tissues that differ in characteristic impedance, a proportion of the energy in the wave is reflected in much the same way that light is reflected when it meets a change in reflectivity at a surface.

The characteristic impedances of soft tissues are similar, so the echoes from their boundaries are very small. For example, only about 0.5 per cent of the

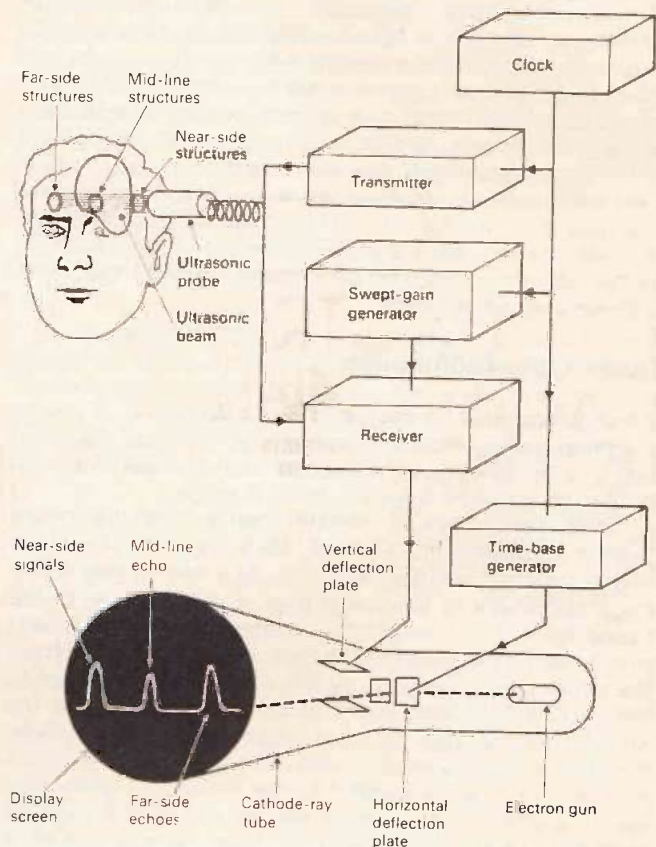

Fig. 1. Basic arrangement of the A-scope system, in use in this instance to show the mid-line structures of the brain in their relative position halfway between the sides of the skull, as indicated by symmetry of the deflections of the cathode-ray tube trace. Asymmetrical spacing of the deflections may mean that disease has brought about a physical change such as a tumour on one side of the brain. The swept-gain generator gradually increases the receiver amplification over each sweep of the time base to compensate for the attenuation of the deeper echoes by intervening tissues.

energy striking the boundary between kidney and fat is reflected. However, such echoes are large enough to be detected by a sensitive receiver, but almost all the energy crosses the boundary and is available for reflection by deeper structures.

Much larger reflections occur at boundaries between soft tissues and either bone or gas, because of large differences in characteristic impedance. These large reflections restrict the use of ultrasound in medical diagnosis. Moreover, it is necessary to exclude air from between the probe and the patient. This may be done either by examining through a water bath or through a film of oil smeared on the patient's skin.

Resolution

Ultrasonic echo-ranging techniques depend on the measurement of the time interval between the transmission of a brief pulse of energy and the reception of its echo, just as in radar. In any imaging system, whether using light, ultrasound or any other kind of radiation, the resolution is limited by the wavelength of the radiation. It is for this reason that ultrasound, as opposed to sound, is used in medical diagnosis. We need to visualise structures of only a few millimetres in size, so that wavelength has to be around a millimetre or less. In soft tissues, it is about 1.5 mm at a frequency of 1 MHz and proportionately less at higher frequencies. The highest audible frequency, about 20 kHz, has a wavelength of 75 mm. In principle, the performance might appear likely to improve as the frequency is increased, but ultrasound is attenuated as it travels through tissues and the rate of attenuation also increases with the frequency, so we have to compromise between better resolution and reduced penetration.

Pulse-Echo Techniques

In an ultrasonic instrument for diagnosis, a probe containing a piezoelectric transducer converts electrical signal into ultrasound waves for transmission into the patient. It does the opposite for the echoes.

The simplest type of ultrasonic pulse-echo diagnostic system is called the A-scope. (See Fig. 1). The clock triggers the transmitter, which feeds a brief pulse with a large amplitude to the transducer. Echoes return to the probe from those reflecting surfaces inside the patient that lie along the ultrasonic beam. Electrical signals from the echoes are amplified by the receiver and applied to the vertical deflection plates of the cathode-ray tube; the time-base generator, which is triggered into operation by the clock at the instant the ultrasonic pulse is transmitted by the probe, is connected to the horizontal deflection plates to drive the spot on the display at a constant speed from left to right. In this way the beam sweeping across the display is deflected vertically at intervals along the horizontal axis, corresponding in distance from the start of the sweep, to echo-producing surfaces at various distances along the ultrasonic beam. A special circuit in the receiver increases the amplification of the deeper echoes to compensate for their attenuation by intervening tissues. The clock operates at a repetition rate fast enough to give a flicker-free trace on the display.

The A-scope has clinical applications in neurology, ophthalmology and internal medicine. It allows the

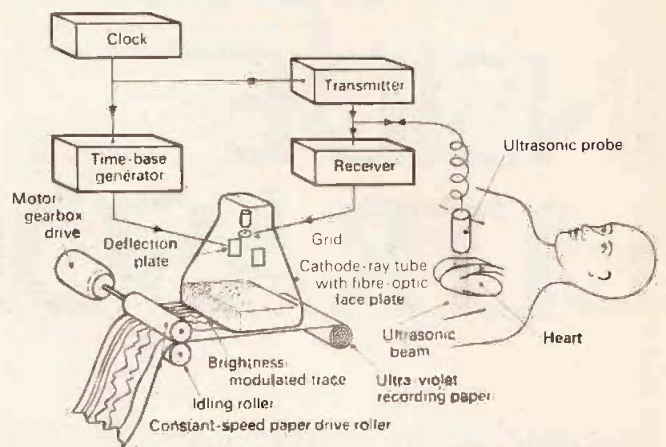

Fig. 2. Time-position recording system based on the B-scope display, shown in use for echocardiography. The fibre-optic face plate of the cathode-ray tube collects enough light to produce a self-developing trace on ultra-violet recording paper.

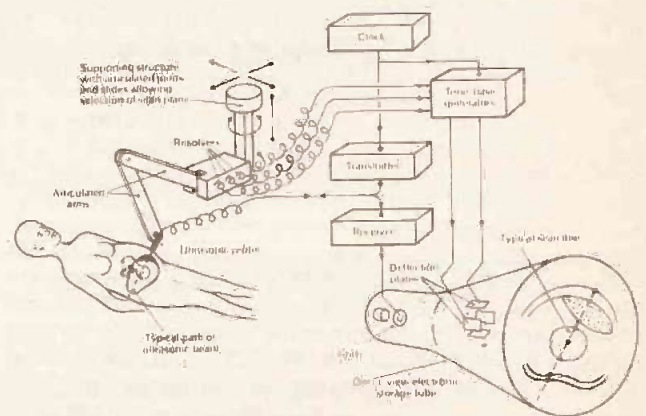

Fig. 3. Two-dimensional scanner and B-scope display system studying a foetus. The time-base generators are driven by electrical outputs from a series of resolvers that measure the position of the ultrasonic beam as it moves across the patient. Horizontal and vertical time-bases combine to deflect the spot in such a way that its movement across the display corresponds to the movement of the beam. Echoes received as the probe moves over the patient produce a cross-sectional image in a plane corresponding to that of the scan. In this example, the image is built-up on the screen of an electronic storage tube for direct viewing.

depths of echo-producing surfaces to be measured, and the characteristics of echoes from within structures to be studied.

Echoes from moving structures, such as the valves of the heart, oscillate in position along the horizontal axis, or time base, of the display. In cardiology particularly patterns of movement can give diagnostic information. They can be studied by making recordings with the aid of a B-scope display (see Fig. 2).

In the B-scope, the time-base sweep is normally visible, but it is brightened by returning echoes to

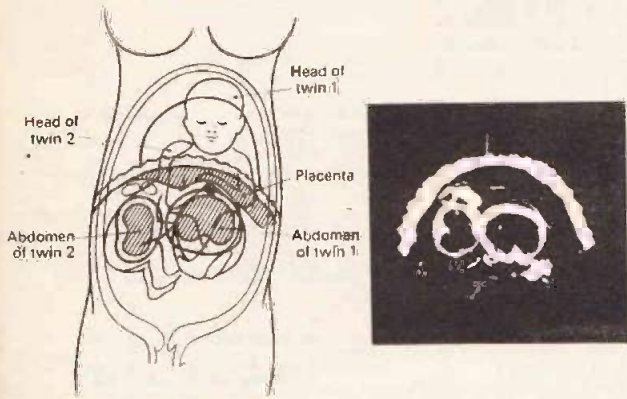

Fig. 4. A two-dimensional scan reveals twins at about 25 weeks of pregnancy. The placenta on the anterior wall of the uterus is clearly defined while the abdomens of the twins, identified in the explanatory diagram, appear in section.

produce spots of light on the display in places where, on an A-scope, there would be deflections of the beam. The positions of the spots of light correspond to echo-producing structures in the patient, and the pattern of their movement can be permanently recorded.

Cross-Sectional Images

The B-scope forms the basis of another display method, the two-dimensional ultrasonic scanner (see Fig. 3). The ultrasonic probe, instead of being held in the hand, is mounted on a scanner. It can be moved to any position in a two-dimensional plane. In this way it is possible to arrange for the beam to pass through structures lying in a chosen plane within the patient, while the position of

the probe and the direction of the beam are measured continuously by 'resolvers' mounted in the scanner. The electrical signals from the resolvers control two time-base generators, driving the vertical and horizontal beam deflection plates of a cathode-ray tube. The direction and position of the ultrasonic beam across the patient controls the position of the cathode-ray beam showing up on the display, related to the positions of the echo-producing surface.

A cross-sectional image of the surfaces can be built up photographically by a camera with an open shutter that records the bright spots on the display while the patient is being scanned. The echo information can also be stored electronically.

Two-dimensional scanners in which the probe is moved in contact with the patient produce individual images in scanning times of about 10 seconds, images can be produced at a much faster rate by moving the probe mechanically. Images in rapid succession allow physiological movements to be studied; their main importance is in cardiological diagnosis. But although these rapid mechanical scanners produce so-called real-time images, they lack flexibility. This difficulty can be overcome by using ultrasonic probes containing many separate transducer elements, operated separately or in groups, which can produce ultrasonic scans made up of parallel lines or lines arranged in a fan shape, at frame rates of tens per second.

As well as making it possible to study rapidly moving structures, real-time scanners can also be used to explore large volumes of anatomy in a short time. A doctor using one can examine a patient in about a quarter of the time it takes with a 'conventional' two-dimensional scanner.

Doppler Effect

The frequency of an ultrasonic wave reflected from a stationary structure is equal to that of the incident wave. If the beam is reflected by a surface which is moving

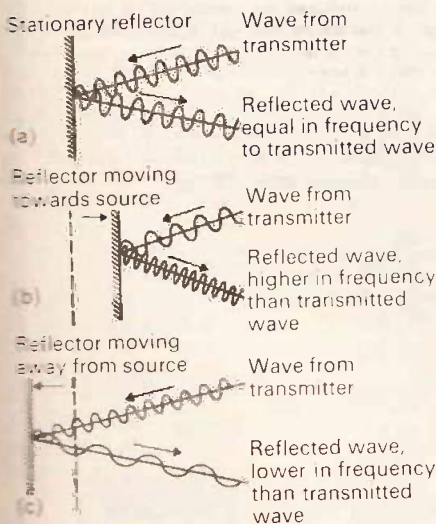

Fig. 5. The Doppler effect occurs when a wave is reflected from a moving surface, giving an upward or downward 'shift' in frequency as in (b) and (c).

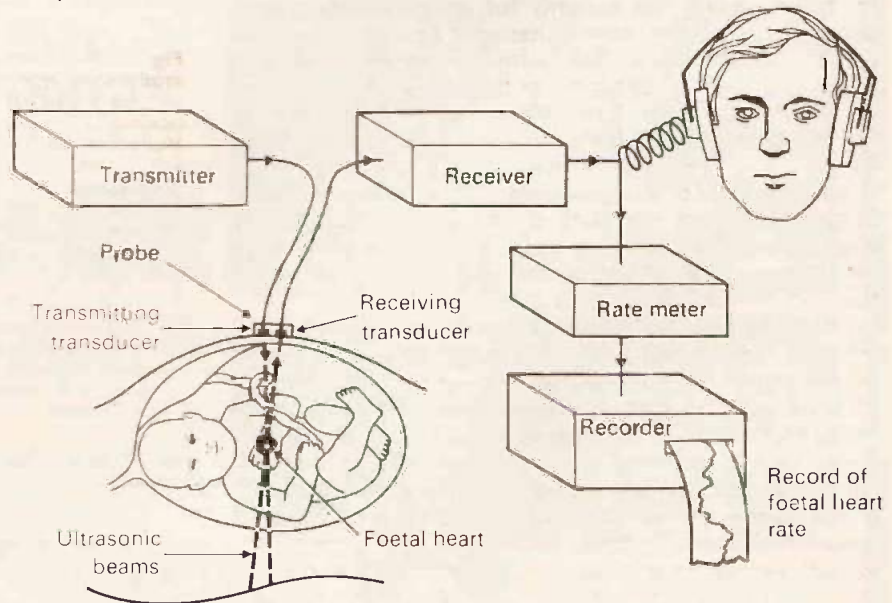

Fig. 6. One use of the Doppler 'shift' is to monitor the foetal heart. The echoes usually fall in the range of audible frequencies.

FEATURE : Ultrasonics

towards the ultrasonic source, the reflected wave is compressed into a shorter space. This means that the wavelength is reduced. It shows as an upward 'shift' in its frequency. Reflection by a surface moving away from the source gives a downward shift. This phenomenon, the well-known Doppler effect, conveniently gives shift frequencies that fall in the audible range when ultrasound is reflected by moving structures in the body such as heart valves or flowing blood. A simple instrument based on this makes it possible to detect the movement of the foetal heart. Similar instruments to measure blood flow allow peripheral arterial disease to be assessed.

Because Doppler shifted signals are received only from structures that move, two-dimensional maps of them can be built up by using a Doppler probe to scan the patient. In this way the distribution vessels close to the surface can be studied. Such information may obviate the need for X-ray angiography, which is a dangerous and expensive procedure.

It can also be combined with other information about structure position obtained by the pulse-echo method, making it possible to map out blood vessels within the body and measure the rate of blood flow at the same time.

The clinical value of ultrasonic techniques has already been proved, but their spread into general, everyday service will depend on the development of instruments that are simple to use. These, paradoxically, may be more complicated than the ones we already have. It will also mean training doctors and technicians to obtain and interpret results. But it is clear that ultrasonic diagnosis is, in many instances, the best and most economical way of getting the information essential to proper care of the patient.

ETI

SINCLAIR PRODUCTS*

Microvision TV £200. PDM35 £27.25, mains adaptor £3.24, case £3.25. 30kV probe £18.95. DM235 £47.50. Rechargeable battery units £7.85. Adapter/charger £3.70. Case £8.50. 30kV probe £18.95. Cambridge prog calculator £13.18, prog library £2.95, mains adaptor £3.20. Enterprise programmable calculator £20.95.

S-DECS AND T-DECS*

S-Dec £3.39, T-Dec £4.44, µ-DecA £4.52, µ-DecB £6.73, 16 dil or 10T05 adaptors with sockets £2.14.

CONTINENTAL SPECIALITIES PRODUCTS*

EXP300 £6.21. EXP350 £3.40. EXP600 £6.80. EXP650 £3.89. EXP4B £2.48. PB6 £9.94. PB100 £12.74. LM1 £30.99. LP1 £33.48. LP2 £19.44.

TV GAMES

Send s.a.e. for free data. New racing car tv games chip AY-3-8603 plus economy kit £20.60. Tank battle chip AY-3-8710 plus economy kit £13.95. stunt motor cycle chip AY-3-8760-1 plus economy kit £12.50. 10 game paddle 2 chip AY-3-8600 plus economy kit £12.50. AY-3-8500 chip plus economy kit £8.95, modified shoot 'em £4.98, rifle kit £4.95, colour generator kit £7.50. Attractively casad assembled tv games Stunt cycle £25.95, tank war game £39.95, 4 game models (tennis, football, squash and polo) black and white £11.95. Colour £14.50.

MAINS TRANSFORMERS

50-5V 100ma 79p. 1 1/2a £2.35, 6.3V 1 1/2a £1.89, 9-0-9V 75ma 79p. 1a £1.99, 2a £2.80, 12-0-12V 50ma 79p, 100ma 90p. 1a £2.49, 13V 1/2a 95p, 15-0-15V 1a £2.79, 30-0-30V 1a £3.59.

JC12, JC20 AND JC40 AMPLIFIERS

A range of integrated circuit audio amplifiers supplied with free data and printed circuits. JC12 6 watts £1.60. JC20 10 watts £2.95. JC40 20 watts £3.95. Send s.a.e. for free data on our range of matching power and preamp kits.

FERRANTI ZN414

IC radio chip £1.05. Extra parts and pcb for radio £3.85, case £1. Send s.a.e. for free data.

PRINTED CIRCUIT MATERIALS

PC etching kits economy £1.70, standard £3.82. 50 sq ins pcb 40p, 1 lb F&C £1.05, etch resist pens economy 45p, dolo 73p, small drill bits 1/32 ins or finer 20p each, etching dish 68p, laminate cutter 75p.

BATTERY ELIMINATORS

3-way models with switched output and 4 way multi-jack 3/4V/6V 100ma £2.51, 6/7 1/2V/9V 300ma £2.78, 100ma radio models same sizes as 9V battery with press stud connectors. 9V £2.85, 6V £2.88, 4 1/2V £2.88, 9V+9V £4.50, 6V+6V £4.50, 4 1/2V+4 1/2V £4.50, cassette recorder mains unit 7 1/2V 100ma with 5 pin din plug £2.85, car converters 12V dc input output 9V 300ma £1.80, output 7 1/2V 300ma £1.60, output 3 1/4V/6 7 1/2V/9 12V 800ma £2.90.

BATTERY ELIMINATOR KITS

Send s.a.e. for free leaflet on range. 100ma radio types with press stud connectors 4 1/2V £1.80, 6V £1.80, 9V £1.80, 4 1/2+4 1/2V £2.50, 6+6V £2.50, 9+9V £2.50, heavy-duty 13 way types 4 1/2V/6 7 1/2V/11/13/14/17/21/25/28/34/42V 1 Amp £4.85, 2 Amp £7.25, transistor stabilized 8-way types for low hum 3/4V/6 7 1/2V/9/12/15/18V 100ma £3.20, 1 Amp £6.40. Variable voltage stabilized models. 2-18V 100ma £3.80, 2-30V 1A £4.95, 2-30V 2A £10.95. Car converters 12V dc input, output 9 7/8V/6 1/4V stabilized £1.85.

BI-PAK AUDIO MODULES

Send s.a.e. for data. S450 tuner £23.51, AL60 £4.86, PA100 £16.71, SPM80 £4.47, BMT80 £6.95 MK80 £38.74, Stereo 30 £20.12.

BULK BUY OFFERS

Minimum purchase £3 any mix from this section. 1N4148 1.3p, 1N4002 3.5p, BC212 8p, 741 8dill 18p, NE555 8dill 29p, 723 14dill 43p, AC78023N exact equiv of SN76023N with improved heat sink 79p. Plastic equivs of popular transistors BC109 4.4p, BCY11 4.7p, BCY12 4.4p. Fuses 20mm x 5mm cartridge 25, 5, 1, 2, 3 5Amp quickblow type 0.7p, anti-surge type 3.4p. Resistors 5% E12 10 ohm to 10M 1/4W 0.9p, 1W 1.5p. Polyester capacitors 250V .01, .022, .033, .047mf 2.7p, 015mf 1.1p, .068mf 1.4p, 0.1mf 1.5p, 0.22mf 3p, 0.33mf 2.8p, 0.47mf 4.5p. Polystyrene capacitors E12 63V 15 to 8200pf 2 1/2p. Ceramic capacitors 50V E12 22pf to 1000pf 1.7p, E6 1500pf to 33000pf 1.7p, 47000pf 1.7p. Electrolytics 50V, 47, 1, 2mf 5p, 25V 5mf 5p, 10mf 4p, 18V 22mf 5p, 33, 47 100mf 8p, 220 330mf 9p, 470mf 13p, 1000mf 12p. Zeners 400mW E24 2p, 33V 5.1p. Preset pots sub-miniature 0.1W horiz or vert 100 to 4M 7.8p. Potentiometers 1/4W 4K7 to 2M2 log or lin single 29p, dual 76p.

SWANLEY ELECTRONICS

DEPT. ETI, 32 Goswell Road, Swanley, Kent BR8 8EZ

Mail order only. Please add 30p to the total cost of order for postage. Prices include VAT. Overseas customers deduct 7% on items marked * and 11% on others. Official credit orders welcome.

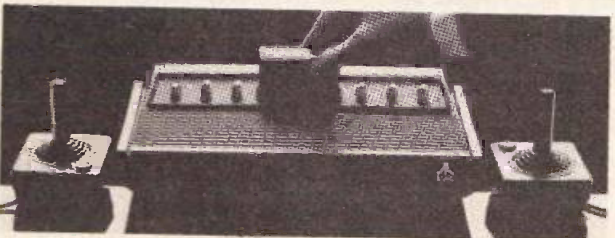
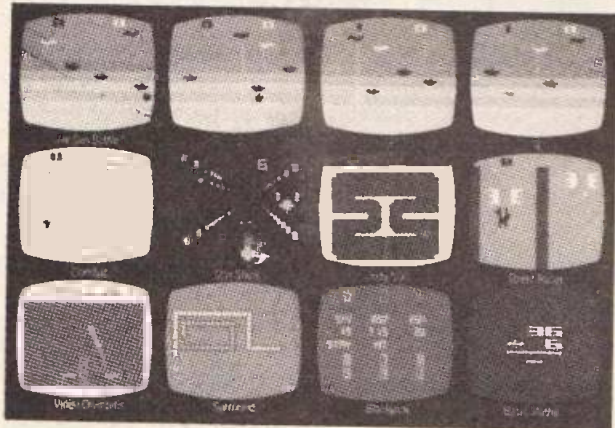

Securicor delivery available
— Add £4.00.



**Discount
COMPUTING**

Please make cheques and postal orders payable to
DISCOUNT COMPUTING, or phone your order
quoting BARCLAYCARD or ACCESS number.



14 STATION ROAD · NEW BARNET · HERTS. TEL: 01-441 2922/01-449 6596
CLOSE TO NEW BARNET BR STATION — MOORGATE LINE
OPEN — 10 a.m. to 7 p.m. — Monday to Saturday

THE WORLD'S MOST ADVANCED
MICROPROCESSOR VIDEO GAME
DIRECT FROM THE USA

THE 'ATARI' VIDEO COMPUTER SYSTEM

— READY BUILT CARTRIDGE SYSTEM
EX-STOCK

192
GAMES

Just look at a few of the numerous games
available to you in multi-colour (on colour
TV's) with realistic sound effects.



This Video Computer System (based on Signetics 2550) is
available complete with the 27 game Combat Cartridge,
multi-function joysticks, mains adaptor and aerial switching
unit. Fully guaranteed for
12 months. **£169.95** **£149.00**
(inc. VAT)



At present there are 9 cartridges available — a total of 192
games — plus many more on the way.
Price per cartridge) **£14.95** **£13.95**
(inc. VAT)

Full colour brochure available on request

EASY BUILD SPEAKER DIY KITS

Specially designed by RT-VC for cost-conscious hi-fi enthusiasts, these kits incorporate two teak simulate enclosures, two EMI 13" x 8" (approx.) woofers, two tweeters and a pair of matching crossovers. Supplied complete with an easy to follow circuit diagram, and crossover components. Input 15 watts rms, 30 watts peak, each unit. Cabinet size 20" x 11" x 9 1/2" (approx.).

£28.00
STEREO PAIR
+ p & p £5.50

SPEAKERS AVAILABLE WITHOUT CABINETS

It's the units which we supply with the enclosures illustrated. Size 13" x 8" (approx.) woofer (EMI), 2 1/2" approx. tweeter, and matching crossover components. stereo pair. Power handling 15 watts rms, 30 watts peak. + p & p £3.40

£17.00 per
stereo pair

BUILT AND READY TO PLAY

SPEAKERS Two models - Duo IIb, teak veneer, 12 watts rms, 24 watts peak, 18 1/2" x 13 1/2" x 7 1/2" (approx.) Duo III, 20 watts rms, 40 watts peak, 27" x 13" x 11 1/2" approx. Duo IIb **£17** p & p £6.50 Duo III **£52** p & p £7.50

EASY TO BUILD



WITH SPEAKERS
NOT TO SCALE

RECORD PLAYER KIT For the D.I.Y. man who requires a stereo unit at a budget price, comprising ready assembled stereo amp module. Gained auto/manual deck with cueing device, pre-cut and finished cabinet work. Output 4 watts per channel, phono socket and record/replay socket including 2 SPHERICAL HiFi speakers. **£19.95** p & p £4.05

AM/FM STEREO TUNER AMPLIFIER CHASSIS COMPLETE

Ready built. Designed in a slim form for compact, modern installation. Rotary Controls Vol On/Off, Bass, Treble, Balance. Push Buttons for Gram, Tape, VHF, MW, LW and 5 button rotary selection switch. Power Supply Selenium Bridge—35V DC from 210 250V AC 50Hz input. Aerial Ferrite 8" x 3/4" built into chassis for LW and MW plus flying lead for FM aerial. Power Output 5 watts per channel. Sine at 2% THD into 15 Ohm 7 watts speech and music. Tape Sensitivity Playback 400mV/30K OHM for max. output. Record 200mV/50K output available from 25KHz (150mV/100K) deviation FM signal. Frequency Range (Audio) 50Hz to 17 KHz within ±1dB. Radio FM sensitivity for 3dB below limiting better than 10 UV. AM sensitivity for 20 dB S/N MW 350 UV/Metre LW 1mV/Metre. Size approx. length 16" x height 2 1/4" x depth 4 1/4". **£19.95** P & P £2.50

VALUE FOR PERSONAL SHOPPERS

- 16A 16 VOLT MAINS TRANSFORMER, 2% amp **£2.50**
- BSR Record auto deck on plinth with stereo cartridge ready wired **£11.95**
- LED 5 function men's digital watch stainless steel finish **£5.95**
- LED 5 function men's digital watch stainless steel finish **£7.95**
- LCD 8 Function CHRONOGRAPH men's digital watch, stainless steel finish **£13.95**
- 125 Watt Power Amp Module **£13.95**
- Mains power supply for above unit **£3.50**
- LENTEK Monitor loudspeaker cabinet size approx. 43 1/4" x 15 1/2" x 15 1/4" **£24.95**
- 30K Multiturn Varicap tuning pots, 6 for **£1.00**
- MUSIC CENTRE CABINET with hinged smoke acrylic top, finished in natural teak veneers, size 30 1/4" x 14 1/2" x 7 1/4" approx. **£5.95**
- MULLARD Built power supply **£1.50**
- BECCA DC 1000 Stereo Cassette P.C.B. complete with switch oscillator coils and tape heads **£2.95**
- BECCA 20w Stereo speaker kit comprising 2 8" approx. bass units + 2 3 1/2" approx. tweeter inc. crossovers **£20.00**
- THEODMASTER Super Score TV Game with postal mains operation **£14.95**
- THEODMASTER Door Tunes (24 different titles) **£12.95**
- MUSIC cassette tape recorder **£13.95**
- TAPE TRANSPORT Mechanism—a selection of models from **£8.95**
- DIGITAL CLOCK RADIO Mains operated **£10.95**
- STEREO RADIO/CASSETTE RECORDER, MW, LW, SW and Stereo VHF 6 watts output Battery mains operation. **£75.00**
- PORTABLE RADIO/CASSETTE RECORDER, AM/FM with clock, LW, MW, SW, VHF mains/battery operation. **£41.95**

Mullard

AUDIO MODULES IN BARGAIN PACKS

CURRENT CATALOGUE
PRICE £
AT OVER **25**
PER PACK

SEE OUR PRICES

- 1** PACK 1 2 x LP1173 10w RMS output power audio amp modules, + 1 LP1182/2 Stereo pre amp for ceramic and auxiliary input.
illus. OUR PRICE **£4.95**
p+p £1.00
- 2** PACK 2 2 x LP1173 10w RMS output power audio amp modules + 1 LP1184/2 Stereo pre amp for magnetic, ceramic and auxiliary inputs.
OUR PRICE **£7.45**
p+p £1.00
- 3** PACK 3 1 x LP1179/2 FM Tuning head with AM gang, 1 x LP1165/1 AM/FM IF module, 2 x LP1173/10w RMS output power audio amp modules + 1 LP1182/2 Stereo pre amp for ceramic and auxiliary input.
OUR PRICE **£9.95**
p+p £1.00

TRADE ENQUIRIES INVITED

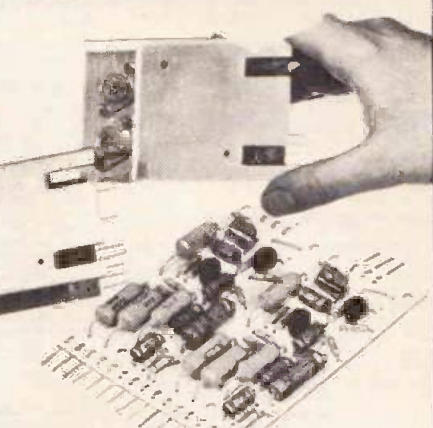

ACCESSORIES

Suitable power supply parts including mains transformer, rectifier, smoothing and output capacitors **£1.00** p+p **£1.95**

Recommended set of rotary stereo controls comprising BASS, TREBLE, VOLUME and BALANCE **p+p 50p 95p**

THIS MONTHS OFFER
added to our bargain packs
When you buy Pack 3 at £9.95, together with a mains transformer at £1.95 and a set of controls for 95p, you receive FREE a Mullard LP1400 Decoder to match listed at £11.90 **£12.85**



20 x 20 WATT STEREO AMPLIFIER
Viscount IV unit in teak-finished cabinet. Silver fascia with aluminium rotary controls and pushbuttons, red mains indicator and stereo jack socket. Function switch for mic, magnetic and crystal pick-ups, tape, tuner, and auxiliary. Rear panel features two mains outlets, DIN speaker and input sockets, plus fuse. 20 + 20 watts rms. 40 + 40 watts peak. **£29.90** p & p £2.50

30 x 30 WATT AMPLIFIER KIT
For the experienced constructor complete in every detail. Similar facilities as Viscount IV amplifier. 60+60 peak. **£29.00** p & p £2.50

* **SPECIAL OFFER: PACKAGE PRICE WITH 30x30 KIT**
Mk II version operates into 4 to 15 ohms speakers. Specially designed by RT-VC for the experienced constructor, complete in every detail. Same facilities as Viscount IV amplifier. 60+60 peak, supplied with 2 **GOODMANS COMPACT 12"** Bass woofers with cropped sides, 14,000 Gauss magnet. 30 watts rms handling + 3 1/4" approx tweeters and crossovers. **£49.00** p & p £4.00

NOW AVAILABLE fully built and tested Output 30+30 watts rms. 60+60 peak. **£39.00** p & p £2.50

ADD-ON STEREO CASSETTE TAPE DECK KIT

Designed for the experienced D.I.Y. man. This kit comprises of a tape transport mechanism, ready built and tested record/replay electronics with twin V.U. meters and level control for mating with mechanism. Specifications: Sensitivity - Mic 0.85 mV ± 20K OHMS; Din, 40mV. 400K OHMS - Output - 300mV RMS per channel ± 1KHz from 2K OHMS source. Cross Talk - -30db; Tape Counter - 3 Digit. Resettable; Frequency Response - 40Hz - 8KHz ± 6db. Deck Motor - 9 Volt DC with electronic speed regulations. Key Functions - Record, Rewind, Fast Forward, Play, Stop & Eject. **£19.95** p & p £2.50. Opt. extras: Mains transformer to suite **£2.50** + £1 p & p.



50 WATT MONO DISCO AMP
£29.95
P & P £2.50
Size approx. 13 1/2" x 5 1/4" x 6 1/4"
50 watts rms. 100 watts peak output. Big features include two disc inputs, both for ceramic cartridges, tape input and microphone input. Level mixing controls fitted with integral push-pull switches. Independent bass and treble controls and master volume. **SPECIAL OFFER:** The above 50 watt amp plus 4 Goodmans Type 8P 8" speakers. Package price **£45.00** + £4.00 P & P

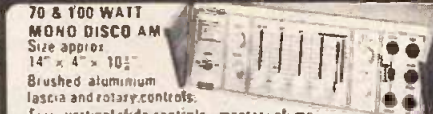

70 & 100 WATT MONO DISCO AM
Size approx. 14" x 4" x 10 1/2"
Brushed aluminium fascia and rotary controls. Five vertical slide controls: master volume, tape level, mic level, deck level. PLUS INTER DECK FADER for perfect graduated change from record deck No. 1 to No. 2, or vice versa. Pre fade level control. 70 watt (PFL) lets YOU hear next disc before fading. 140 watt peak. **£57** p & p £4.00
Output 100 watts RMS 200 watts peak. 100 watt **£65**



BSR 95 TYPE Belt drive chassis turntable less cartridge **£2.55** p & p **£24.95**
BSR MP60 TYPE Single play record player less cartridge. **£15.95** £2.55 p & p
CARTRIDGES to suit above Tenorel magnetic stereo. **£4.95**

BSR automatic record player deck, cueing device and stereo ceramic head. **£2.55** p & p **£9.95**
GARRARD DECK CC10A. Record changer with cue and stereo ceramic cartridge. Size 12" x 8 1/2" approx. **£2.00** p & p **£7.95**



GARRARD 868B Deck **£24.95** **GARRARD SP25 MKIV Deck** with Shure head. **£26.95**
GARRARD 355B Deck **£24.95**



Order by giving credit card number ONLY.
323 EDGWARE ROAD, LONDON W2
21E HIGH STREET, ACTON W3 6NG
ALL PRICES INCLUDE VAT AT 12 1/2%
All items subject to availability. Price correct at 1.10.78 and subject to change without notice.



PORTABLE DISCO CONSOLE
Here's the big-value portable disco console from RT-VC! It features a pair of BSR MP 60 type auto-return, single play professional series record decks. Plus all the controls and features you need to give fabulous disco performances. Simple connects into your existing slave or external amplifier. **£64.00** p & p £6.50

Personal Shoppers EDGWARE ROAD LONDON W2 Tel: 01-723 8432. 9.30am-5.30pm. Half day Thursday. ACTON: Mail Order only. No callers. GOODS NOT DESPATCHED OUTSIDE UK

B. BAMBER ELECTRONICS

DEPT. ETI, 5 STATION ROAD, LITTLEPORT, CAMBS. CB6 1QE
Tel. ELY (0353) 860185 (Tues. to Sat.)

CASH WITH ORDER. (MINIMUM ORDER £2.00)
PLEASE ADD VAT AS SHOWN
POST PAID (UK ONLY). SAE WITH ENQUIRIES
CALLERS WELCOME BY APPOINTMENT ONLY

ALL BELOW — ADD 8% VAT

IC TEST CLIPS, clip over IC while still soldered to pcb or in socket. Gold plated pins, ideal for experimenters or service engineers. 28 pin DIL £1.75, 40 pin DIL £2.00. Or save by buying one of each for **£3.50**

MAINS TRANSFORMERS, TYPE 15/300 240V input 15V at 300mA output. £1.50 each

MAINS TRANSFORMERS, TYPE 45/100, 240, 220, 110, 20, 0V input. 45V at 100mA output. £1.50 each.

SLOW-MOTION MOTORS, 120V 50Hz 1RPM. Size approx 2 dia. x 1 1/2 deep, with 3/4 spindle, 60p each, or 2 for £1.00

1.2V DC MOTORS (ideal for model makers, quite powerful). 50p each

SUB-MINIATURE ROTARY SWITCHES, 4 x 5-way make contacts. Size approx 3/4 dia. x 1 deep 3/16 spindle. 50p each

30pin BEEHIVE TRIMMERS, Brand new, 4 for 50p. **Min. 50p AIR SPACE TRIMMERS**, approx 3/4 square, 3 for 50p

Min. 50p COMPRESSION TRIMMERS, 1/2 x 5/16, 4 for 50p

LARGE ELECTROLYTIC PACKS, Contain range of large electrolytic capacitors, low and high voltage types, over 40 pieces. **£3.00** per pack (+ 12 1/2% VAT)

FULL RANGE OF BERNARDS BABINI ELECTRONICS BOOK IN STOCK S.A.E. FOR LIST

A NEW RANGE OF QUALITY BOXES & INSTRUMENT CASES

Aluminium Boxes with Lids	
AB10	5 1/2 x 4 1/2
AB13	6 x 4 1/2
AB14	7 x 5 1/2
AB15	8 x 6 1/2
AB16	10 x 7 1/2
AB17	10 x 4 1/2 x 3 1/2
AB25	6 x 4 1/2

Vinyl Coated Instrument Cases

Blue Tops with Plain Lower Sections		Very smart finish	
WB1	5 1/2 x 4 1/2 x 1 1/4		75p
WB2	6 x 4 1/2 x 1 1/4		£1.35
WB3	8 x 5 1/2		£1.80
WB4	9 x 5 1/2 x 2 1/4		£2.00
WB5	11 x 7 1/2 x 3		£2.50
WB6	11 x 7 1/2 x 3 1/4		£2.85
WB7	12 x 8 1/2 x 3 1/4		£2.85
WB853	8 x 5 1/2 x 3 1/4		£2.25

ALL BELOW — ADD 8% VAT

MIXED COMPONENT PACKS, Containing resistors, capacitors, switches, pots, etc. All new, and hundreds of items. **£2.00** per pack, while stocks last

IC AUDIO AMP PCB, Output 2 watts into 3 ohm speaker. 12V DC supply size approx 5 1/2" x 1 1/2" x 1 1/2" high, with integral heatsink, complete with circuits. **£2.00** each

NICAD CHARGER CONVERTER PCB, (Low power inverter) Size approx 4" x 1 1/2" x 1" high, 12V DC supply, 60V DC output through pot on pcb, for charging Nicads, etc. (ideal for charging portable battery from mobile supply) Only needs one BEV50, 51, 52 or similar transistor, which can be mounted direct on the pcb pins on board, fitted with a star type heatsink (not supplied). **£2.00** each

THE NEW EAGLE INTERNATIONAL CATALOGUE IS AVAILABLE ON REQUEST containing: Audio, In-CAP and test equipment, etc.

DECIMAL KEYBOARDS, pressure sensitive type when pressed contacts go from 0 to C approx. 25 ohms. Switches only, no encoders. Size approx. 3 x 3 with large square touch plates. D. 9/16" Clear A/B. Dual w/switch and spare. Few only. **£2.00** while stocks last.

TRANSISTORS

BFY51 Transistors	4 for 60p
BCY72 Transistors	4 for 50p
BSX20 VHF osc./mult. 1	3 for 50p
BC107 (metal can)	4 for 50p
BC108 (metal can)	4 for 50p
PBC108 (plastic BC108)	5 for 50p
BF152 (VHF amp / mixer)	3 for 50p
2N3819 Fet	3 for 60p
BCY48 NPN SILICON	4 for 50p
BC158 PNP SILICON	4 for 50p
8AY31 Signal Diodes	10 for 35p
74106 ICA GP Amps	4 for £1.00
SCR5400V at 3A, stud type	2 for £1.00
TIP2955 Silicon PNP power transistor	50V at 1.5A, 90 Watts. Flat pack type 2 for £1.50
GERMANIUM DIODES	approx 30 for 30p
1N4148 (1N914) diodes	10 for 25p

VALVES

00V03/20A (ex equipment)	£3.00
00V03/10 (ex equipment)	£3.00 or 2 for £1.20
6B8H (ex equipment)	2 for 50p

All the above valves are untested, except for heaters, and no guarantee of percentage of emission is given. Sorry, no returns.

MULLARD 85A2 85V STABILISER VALVES (brand new) 70p each or 2 for £1.20.

ALL BELOW — ADD 8% VAT

RED LEDs (Min type) 5 for 70p
VIDICON SCAN COILS (Transistor type, but no data) complete with vidicon base. **£6.50** each. Brand new
AEI CS108/R MICROWAVE DIODES, up to 100mA, max noise figure 8:5dB at 9.375GHz. **80p** each

DIE-CAST BOXES

SIZE approx.	Price
4 3/4 x 2 3/4 x 1 1/2 (111 x 60 x 38mm)	£1.25
4 8/8 x 2 3/8 x 1 5/8 (121 x 60 x 38mm)	£1.75
4 8 x 3 8 x 2 (121 x 95 x 25mm)	£2.10
6 8 x 4 8 x 2 (171 x 121 x 51mm)	£2.45
4 8 x 3 8 x 3 (121 x 95 x 76mm)	£3.10
6 8 x 4 8 x 4 (171 x 121 x 101mm)	£4.47
6 6 x 5 8 x 2 (222 x 146 x 51mm)	£4.25
10 6 x 8 8 x 2 (273 x 171 x 51mm)	£5.30

SPIRALUX Tools for Electronics enthusiasts. SAE for list

4MHz XTAL PACKS (10 assorted xtal between 4MHz and 5MHz). Our selection only **£1.00** each

SOLDER SUCKERS (Plunger Type)
Standard Model. **£5.50**
Skirted Model. **£6.00**

Spare Nozzles, 65p each
WELLER WP60D Mains operated temperature control soldering iron. **£15.00**

SPARE TIPS (for WP60D) Two types available. TYPE CC7 (W60D) Standard. TYPE AA7 (W60D) Finer tip. **£3.00** each

WELLER TCP2 temperature controlled soldering iron, and PU20 power unit (replaces Weller TCP1) iron + PSU **£30.00**. Spare tips CC7 (standard), or K7 (finer tip) **£1.50** each

Slider Switches, 2 pole make and break (or can be used as 1 pole change-over by linking the two centre pins). 4 for 50p

PLASTIC PROJECT BOXES, with screws on fits (in black ABS) with brass inserts.

Type NB1 approx 3 x 2 1/4 x 1 1/4 45p each
Type NB2 approx 3 1/2 x 2 1/4 x 1 1/4 55p
Type NB3 approx 4 1/2 x 3 1/4 x 1 1/4 65p each
Type NB4 approx 8 1/2 x 5 1/4 x 3 1/4 £1.50 each

Slider Switches, 2 pole make and break (or can be used as 1 pole change-over by linking the two centre pins). 4 for 50p

OSMOR 10V REED RELAY COILS (1k ohm coil) to fit 1/2" ferrites (not supplied), 2 for 50p

HF CHOKES wound on 1/4" x 1" long ferrites, 4 for 50p

VHF CHOKES wound on 6-hole tubular ferrites, 5 for 40p

ALL BELOW — ADD 8% VAT

DUAL TO18 HEATSINKS 1 x 1/2 x 1/4 with screw-in clamps, 3 for 50p

GLASS BEAD FEEDTHROUGH INSULATORS, solder-in type overall dia 5mm, pack of approx. 50 for 50p

LARGE GLASS BEAD FEEDTHROUGH INSULATORS, as above but 8mm dia, pack of approx. 50 for 70p

20V RELAYS, PCB mounting type, single pole change-over, 35p each

10 MHz SSB XTAL FILTERS (2 kHz Bandwidth) Low imp. type. Carrier and unwanted sideband rejection min. -40dB (need 10 69835 & 10 70185 xtal for USB/LSB. NOT SUPPLIED) Size approx. 2" x 1" x 1" **£10.00** each

LOW PASS FILTERS (low imp. type), 2.9MHz, small metal encapsulation, size approx 1 1/2 x 3/4 x 3/4, 75p each

ALL BELOW — ADD 12 1/2% VAT

CELESTION B x 5 ELLIPTICAL SPEAKERS 20 ohm 3 watts each. **£1.50** each + 12 1/2% VAT

VARICAP TUNERS, Mullard type, ELC1043/05, **£5.00**

BSR AUTOCHANGE RECORD PLAYER DECKS with cue device 33-45-78 rpm, for 7" 10" 12" records. Fitted with SC12M Stereo Ceramic cartridge and stylus. Brand new. **£14.00** + 12 1/2% VAT

GARRARD AUTOCHANGE RECORD PLAYER DECKS, Model 6300, with cue device, 33-45-78 rpm, for 7" 10" 12" records. Fitted with KS418 Stereo Ceramic cartridge and stylus. Brand new. **£16.00** + 12 1/2% VAT

TV LINE LINEARITY COILS, Special offer 10 for **£1.00**

TV SCAN COILS 8/W, to fit 110 degree tubes. **£1.00**

TV Plugs (metal type), 4 for 50p

3 pin Din Plugs, 4 for 50p

Din 3 pin Line sockets, 15p each

Din Speaker Sets, 2 pin, 4 for 30p

Dubiler Electrolytics, 500uF 450V, 2 for 50p

Oubiler Electrolytics, 100uF 275V, 2 for 50p

TCC Electrolytics, 1000uF 30V, 3 for 60p

Dubiler Electrolytics, 5000uF 35V, 50p each

ITT Electrolytics, 6800uF 25V, high grade, screw terminals, with mounting clips, 50p each.

Resistor PK5 approx 300 pieces 1/2 to 2 watt types, mixed values, our selection, **£1.00** each

A RANGE OF CAPACITORS AVAILABLE AT BARGAIN PRICES. SAE FOR LIST.

Buy direct from the importers
and get more scope for your money
KRAMER & CO.

4" Oscilloscope for under **£100**

(as recommended by ETI)

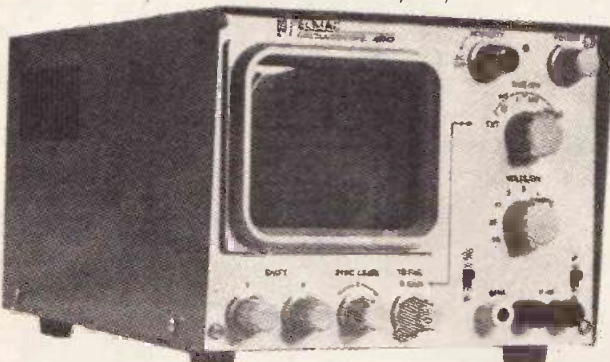

Eimac 4810

SPECIFICATIONS

ELECTRICAL DATA
VERTICAL AXIS (Y) Deflection Sensitivity — 100mV/division Bandwidth (between 3dB points) — DC — 5MHz; Input Attenuator — (calibrated) — 9 step 0.1, 0.2, 0.5, 1, 2, 5, 10, 20, 50/uV Input Impedance — 1 Meg. 40 pF in shunt; Input Voltage — Max — 600V P.P.
HORIZONTAL AXIS (X) Deflection Sensitivity — 0.400cm/V; Division Bandwidth (between 3dB points) — 1Hz-350KHz; Gain Control — Continuous when time bases in EXT position; Input Impedance — 1 Meg; Input Voltage — Max — 600V P.P.
TIME BASE Sweep Range (calibrated) — 100ms/cm/div to 1u sec/div in 5 steps FINE Control — Variable between steps — includes time base calibration position; Blanking — Internal — on all ranges; SYNCHRONISATION: Selection — Internal, external; Synchronisation Level — Continues from positive to negative
POWER SUPPLY Input voltage — 115/220V AC + 10% at 50/60Hz; Power Dissipation — 18W
CRT DATA — 4in — flat face, single beam. — Maximum high voltage — 1.5kV. — Fitted with 8x10 division blue filter graticule
PHYSICAL DATA Dimensions — 15cm (h) x 20.5cm (w) x 28cm (d) Weight — 4.3Kg (approx.) Stand — 2 position flat and inclined. Case — Steel, epoxy enamelled. Front Panel — Aluminium, enamelled epoxy printing

Cash with order

Test leads available £2.00

£99 (+ £7.92 V.A.T. and £2.08 carriage. Total £109)

Oscilloscope Offer, Kramer & Co. 9 October Place, Holders Hill Road London NW4 1EJ

Tel: 01-203 2473 Telex 888941. Attn: Kramer K7 University, School, Company and Government orders accepted by telex and telephone. Callers by appointment only

LISTEN TO THE SECRET WORLD OF PLANTS

As featured on Horizon, Nationwide, Radio and Worldwide Press

FIRST TIME IN THE U.K. IN KIT FORM, THE REVOLUTIONARY CONCEPT OF A BIOLOGICAL AMPLIFIER AND SOUND SYNTHESISER IN ONE UNIT, THE AMAZING

Bio Activity Translator

- ★ Experience the unique musical form of plants
- ★ Hear the beautiful patterns of sound — created by their natural response
- ★ Compare house plants reactions to people — with the distinct tunes of those outside
- ★ Easy to operate, internal speaker and batteries



The naturally generated bio electrical potential across a plant leaf is picked up by 2 carbon foam electrodes. When amplified and filtered, a VCO, VCA and other ingenious synthesiser circuits are programmed by the control voltage from the plant to produce tracking sequences of notes. These follow in pitch, rhythm and volume the ever changing signal from the plant.

The Kit includes 6 I.C.'s, 2 transistors, all high quality components, tinned and drilled fibreglass p.c.b., loudspeaker and comprehensive assembly instructions. Also included is a free case, ready punched, with wooden end cheeks and stick-on silk-screened front panel for a really professional finish. Runs on 2 4 1/2-volt batteries (not supplied).

SPECIAL INTRODUCTORY OFFER INCLUDES FREE CASE

KIT £19.90 ASSEMBLED AND TESTED £27.50 Price includes P & P and VAT

Allow 21 days for delivery. Send cheque or postal order to (Mail Order only)

JEREMY LORD SYNTHESISERS (DEPT. ETI)
7 LONDON STILE, LONDON, W.4

audiophile.....

A woeful tale of the pre-amp to make you red in the face this month. Crimsons CPR1 considered by Ron Harris who recovered enough to visit Sony's launching of sixty new models!

MEANWHILE back at the Crimson pre-amp, I shall begin this month by finishing what I began last, and furnishing details of the CPR1 module. To begin with, quoting specs would be largely superfluous in this context, but as I know there are some of you out there high on numbers, try these for size:

SENSITIVITY: 3.4 mV RMS (1kHz) — mag
70 mV RMS 1kHz all others

for 770 mV RMS output

SIGNAL/NOISE: —70dB unweighted 10kHz bandwidth
mag
—86dB unweighted 10kHz bandwidth
others

CROSSTALK: —80dB 20 Hz-20 kHz
THD: .008% any level below clipping

There are pages of figures in the leaflets Crimson issue for free, so if you've at all interested get after one of those. The nice thing about these specs is their completeness — nothing hidden away here in shrouds of triviality. All the parameters are given as test results under very precise conditions. I could find no reason to argue with any of them and as I'm usually mean and nasty about such things Crimson should take that as praise indeed.

Building Up To It

Power requirements are simply 15-0-15 at under 100mA, and mine measured in the region of 40mA per channel while in full flow. Crimson naturally produce a PSU for this, and it is termed not unreasonably REG1.

The pre-amp arrives as an assembled PCB with set of application notes, and as such cannot be considered a kit by any but the most stretched imagination. Not for the beginner this, as a fair bit of experience comes in most handy — although the notes are very good (but poorly produced) and if you're feeling brave by all means get stuck in — I shan't say 'I told you' — not too loud anyway.

After a few minutes fussing around with pen and paper I decided to house pre-amp and PSU in separate boxes — with appropriate nod in direction of Meridian — for reason of neatness and hum foiling. Let me say now that these circuits are good enough to merit such attention.

As there are no tone controls, metalwork is simplified if I'm glad to say, and for a basic system should be very good indeed.

Crimson make out a very good case in their design notes for doing things their way, but nonetheless there are a few things I would like to disagree with.

Firstly they feed straight into the volume control with auxiliary inputs via the selector switch. This presents the equipment driving into the amp with a varying load, and I would personally prefer to see a high impedance buffer in there, with a lower sensitivity, than the 70 mV now prevailing, and a higher input impedance. A small point perhaps, but under music conditions a constant load is to be preferred I feel.

Secondly the magnetic input is 'fairly' standard although better than most. I would differ from Crimson philosophy enough to prefer the idea of buffering the cartridge input at a constant value, say 47k//200p with unity gain in the first stage, picking up equalisation over two further stages both run at lower gain than usual. This configuration results in a cleaner sound with better transient performance providing the capacitance of each stage is carefully designed for.

I'm offering up these ideas for perusal, not criticising Crimson in particular, its just that the Crimson approach encourages you to drag out your personal theories and give 'em a good airing. I'd be very interested to hear from any of you out there with your ideas on how audio design should be done — we'll print the best we get.

Back To Wires

Anyway to return to the point the CPR1 auditioned very well indeed. Mind you our first sample gave me a hard time for a while. It kept doing things it couldn't do and doing them when I least expected it. After a few bottles of Vallium and several hair pulling sessions with Crimson we discovered I'd been given a non-production board. A quick GPO job and we're back in business. Sanity is saved.

I still don't know what the odd sample was up to — and don't intend to find out any further that way lies madness. I suspect Crimson save that board to assassinate reviewers in the most fiendish way possible. Who'd believe it was murder?

The production model has never given the slightest problem and has behaved impeccably throughout. I compliment Crimson on the attentive way they panicked along with me over the rogue PCB, several poor unsuspecting boards now on soak test because of my nervous breakdown.

Inputting Pickups

To use this input, you add a passive network to the input to optimise loading for the particular device in use. Crimson themselves recommend adding several networks and switches to increase flexibility. I don't. Switches at this signal level are a menace — if you don't believe me, see Stan Curtis's article elsewhere in this

issue. Leave out the switches and hardware for your choice of pickup — how often do you change anyway?

With the switches added a thickening of detail occurs, and transients don't transient nearly as well.

Other inputs are straightforward, although perhaps a little low on input impedance. Noise and hum were commendably low on all inputs, and the separate boxes earn their worth on first power-up. The ten second switch-on blank period to eliminate 'clunks' is a great idea, although on both my samples the delay was so long I almost had time to go make a cup of tea before power came through.

It can be most detrimental to confidence to be left standing there, soldering iron still smoking, poised over the completed unit hand on power switch counting off seconds wondering why the b... hell it hasn't come on yet. Smiles fade rapidly like that.

Listen In

On magnetic input the Crimson CPR1 produced a very nice sound indeed, of very high quality with good detail and fair extension into the bass registers. On a quick A-B with a very highly priced integrated amp the CPR1 surprised me by showing itself clearly superior! OK wiseguy — wheel out the heavies.

Now my personal idol amongst pre-amps is the Lecson AC1 which I feel has never been approached for quality of reproduction, at any price. As such it makes an excellent reference against which to judge lesser machines. However not everyone agrees, and a champion of the Naim offered up his favourite to give the Crimson a run.

You can see from the opposition how seriously the CPR1 managed to get itself taken. Against the Lecson it was frankly outclassed. The AC1 had better depth, and better bass control. Treble came out smoother from the Lecson showing up the Crimson as slightly hard in this register. Mind you the Lecson costs nearly ten times as much and the Crimson gave a very good account of itself.

Comparing it with the Naim unit nearly lost me a friend. I preferred the CPR1! There was not much in it mind you, and Crimson can be justly proud to have produced a home build design capable of this level of performance.

grumbles

A few niggles. The balance control is very limited in operation. More so than is even trendy, never mind useful, and a little extra swing would do no harm. I'm not at all happy about those auxiliary inputs really, but they seemed to cause no problems so I'll shut up about them.

In order to obtain the level of performance the design can offer very careful construction is required. All cables screened. All as short as possible. Good soldering. Good earthing. Isolated PSU and sound routing of cables carrying HT — away from anywhere at signal level. Leave the on-off switch on the PSU box so that mains need not even enter the case.

Also the subjective quality, although of a very high quality, is a little hard, and judged against the best designs around slightly lacking in detail. Still none of this detracts from the fact that here we have a DIY amplifier that can compete with the very best commercial units, and make mincemeat of many far higher priced designs. Highly recommended.

Outlook: Warm and Sony

Sony have gone berserk. Only gone and scrapped practically their entire hi-fi range they have and launched no less than 60 new models if you please. Its enough to give leaflet collectors a heart attack. There is some very clever gadgetry in amongst the flock, and scattered here before you are some of the gems.

The TA-E88 looks very, very interesting indeed, representing as it does the state-of-the-art for Japanese pre-amp design. I'm at present still on my knees to Sony (and my trousers are wearing out fast) to get a closer look so hopefully more details on that one later (Please Mr Sony? . . . Sir?).

The G1 and G7 speakers came as a surprise too, they're better than any oriental offering previously to assail my ear drums, and are capable of giving any competitor a good run for its cones.

They have divided up the dealers too, creating a new super-fi franchise. This basically means that only the best dealers can sell the best of the range, although the division looks to be a bit unsure in places.

ETI

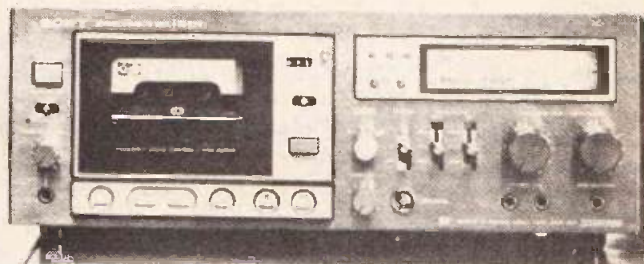

And here we have the TC K8B the new £469 cassette deck released as part of the super-fi Sony range. It incorporates that magnificent LCD display (details on the right) and on the short listen so far gave an excellent audio account of itself.

Below: the G1 speakers. Very good indeed for the price (circa £190 the pair) and deserving of none of the usual anti-Japanese speaker bias. Give them a listen if you get the chance.



LCD Peak Programme Meter

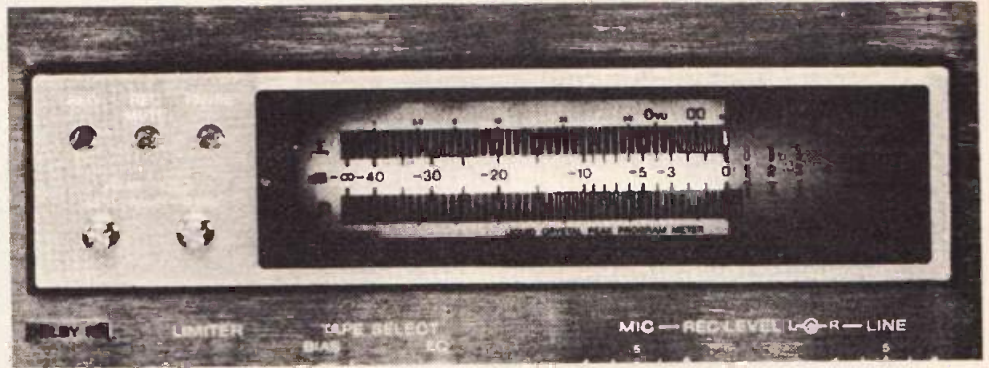
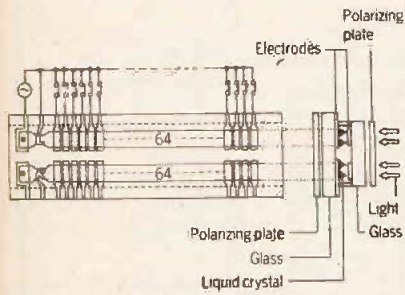

Above: the LCD level meter as used in the TCK8B in close-up. This uses 64 segments to indicate signal level, and has red settable stops to hold peak values. The colours are nice too!

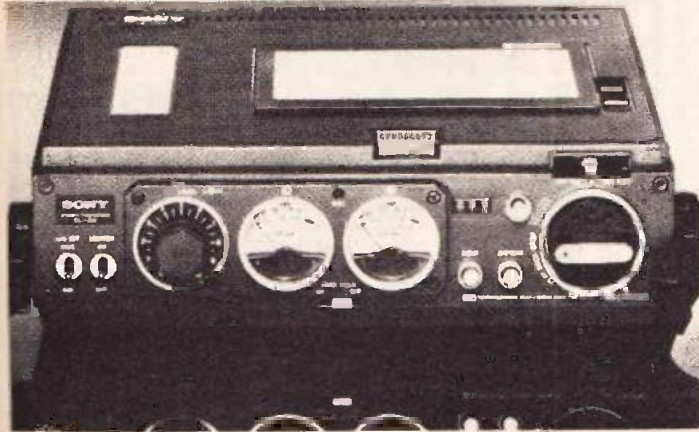

This is a nice touch. A portable Elcaset machine. Gives really nice reproduction and is quite easy to cart around. All the controls are mounted so as to be accessible when in mid-carry. The format would seem to be ideal for this usage. All the quality of a reel-to-reel and no fiddling about while rapidly unspooling tape in a gale! Priced sensibly at £459 and called the EL D8 for the wandering rich amongst you.

Not that I'm obsessed with cassette decks or anything, but here's another one. The TC K6B this time. It's main little gimmick is the MPU program selector. That little LED display in the centre can be stepped to read the number of the track you wish to hear. The machine will promptly go and find it and play it for you. Again LCD level meters, although not as good as the TC K8Bs obviously less segments. Below: The incredible TA88B. The unit has two COMPLETELY separate channels inside its box. Selectable phono load on one input, and one straight in for people who don't like switches in line (Like me) at this low level. Moving coil pre-pre amp is standard of course. Price £699 (What did you expect?)

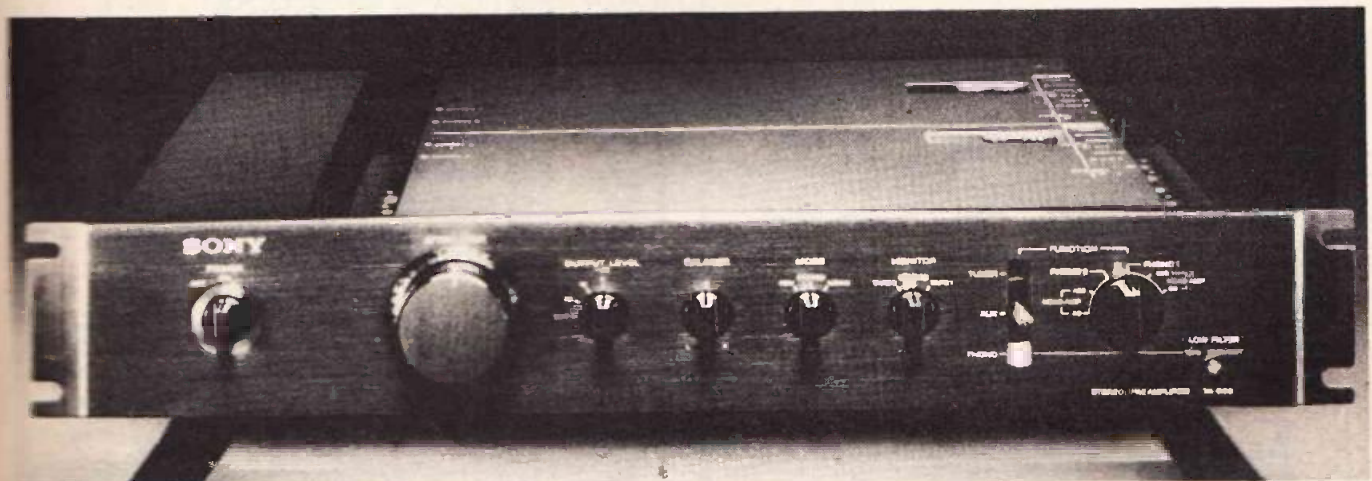
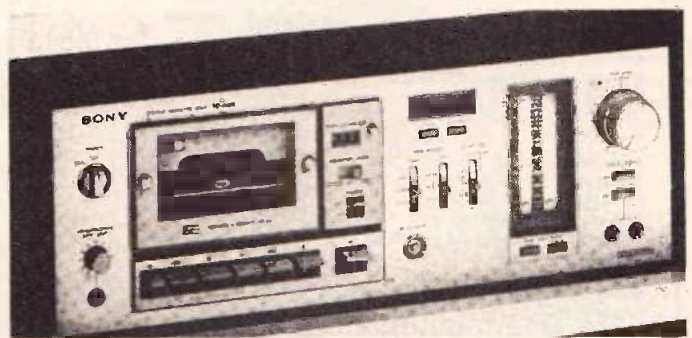

AS RECOMMENDED
BY ELECTRONICS TODAY
INTERNATIONAL JULY 1978

4" Oscilloscope

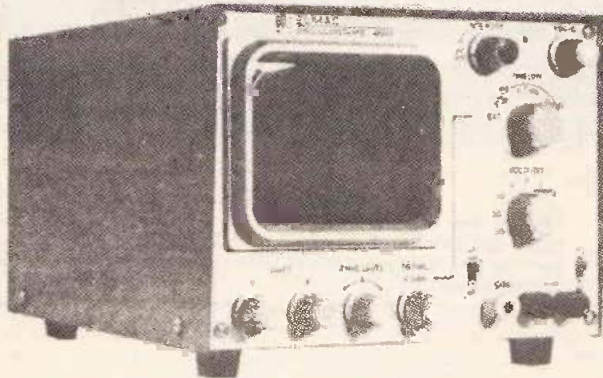

ALTERNATIVE MODEL

3" OSCILLOSCOPE

otherwise specification as 4" model

£85.50

Add VAT £7.34
Carriage £1.50

FROM STOCK
SOLE UK
IMPORTERS

FROM STOCK

£99

Add VAT £7.92
Carriage £2.08

Appointed
London Stockist

SPECIFICATIONS

ELECTRICAL DATA
VERTICAL AXIS (Y)
Deflection Sensitivity
Bandwidth (between 3 dB points)
Input Attenuator — (calibrated)
Input Impedance
Input Voltage — Max
HORIZONTAL AXIS (X)
Deflection Sensitivity
Bandwidth (between 3dB points)
Gain Control
Input Impedance
Input Voltage — Max
TIME BASE
Sweep Range (calibrated)
FINE Control

Blanking SYNCHRONIZATION

Selection
Synchronization Level
POWER SUPPLY
— 115/220V AC ± 10% at 50/60Hz
Power Dissipation

CRT DATA

PHYSICAL DATA
Dimensions
Weight
Stand
Case
Front Panel

— 100m V / division
— DC — 5MHz
— 9 step 0.1, 0.2, 0.5, 1, 2, 5,
10.20 50V/div
— 1 Meg/40 pF in shunt
— 600V P.P
— 0.400mV/division
1Hz-350KHz
— Continuous, when time
base in EXT position
— 1 Meg
600V P.P
— 100msec/div to 1 μ sec/
div in 5 steps
— Variable between steps —
includes timebase calibration
position
— Internal — on all ranges

— Internal, external
— Continues from positive to
negative
Input Voltage
— 18W
— 4in. — flat face, single
beam
— Maximum high voltage —
1.5kV
— Fitted with 8x10 division
blue filter graticule
— 14cm (h) x 20.5cm (w) x
28cm (d)
— 4.3Kg (approx)
— 2 position, flat and in-
clined
— Steel, epoxy enamelled
— Aluminium, enamelled
epoxy printing

Also available from 248 Tottenham Court Road
London W1

301 Edware Road, London W2

HENRY'S
RADIO

All mail to: Henry's Radio 404 Edgware Rd, London W2

LONDON W2-404 6 Edgware Road Tel: 01-723 1008

Greenbank Electronics

CMOS

These cut prices for Amateur Users and Export. Note: Industrial users — quantity prices available.

Mostly Motorola, RCA			
4000	17p	4050	48p
4001	17p	5051	72p
4002	17p	5052	72p
4006	17p	4053	72p
4007	18p	4054	£1.10
4009	50p	4055	£1.25
4010	50p	4057	£25.70
4011	18p	4059	£4.00
4012	18p	4060	£1.15
4013	42p	4061	£15.67
4014	86p	4062T	£10.00
4015	86p	4063	£1.09
4016	45p	4064	N/S
4017	89p	4065	N/S
4018	89p	4066	57p
4019	48p	4067	£3.80
4020	99p	4068	25p
4021	91p	4069	25p
4022	86p	4070	23p
4023	20p	4071	21p
4024	66p	4072	21p
4025	19p	4073	21p
4026	£1.80	4075	25p
4027	45p	4076	85p
4028	81p	4077	25p
4029	99p	4078	21p
4030	99p	4081	29p
4031	£2.05	4082	21p
4032	£1.00	4083	74p
4033	£1.45	4086	73p
4034	£1.96	4089	£1.50
4035	£1.11	4093	63p
4036	£2.45	4094	£1.90
4037	£1.00	4095	£1.05
4038	£1.08	4098	£1.05
4039	£2.45	4097	£2.72
4040	£1.05	4098	£1.10
4041	80p	4099	£1.45
4042	75p	40661	N/S
4043	94p	40100	£2.30
4044	90p	40101	£1.51
4045	£1.45	40102	£2.12
4046	£1.24	40103	£2.12
4047	87p	40104	£1.09
4048	50p	40105	£1.06
4049	49p	40106	71p
			4512

(National etc.) 7400 Series

74C00	24p	74C85	£1.29	74C164	£1.04	74C905	£7.26
74C02	24p	74C86	64p	74C165	£1.04	74C906	54p
74C04	24p	74C89	£4.38	74C173	90p	74C907	54p
74C08	24p	74C90	85p	74C174	£1.51	74C908	96p
74C10	24p	74C93	85p	74C175	90p	74C909	£1.63
74C14	£1.41	40108	£1.04	74C192	£1.10	74C910	£6.78
74C20	24p	74C107	£1.22	74C193	£1.11	74C911	TBA
74C30	24p	74C150	£4.12	74C195	£1.04	74C912	£7.13
74C32	24p	74C151	£2.46	74C200	£6.78	74C914	£1.41
74C42	92p	74C154	£3.67	74C221	£1.36	74C915	£1.10
74C46	£1.38	74C157	£2.20	74C373	£1.73	74C918	£1.06
74C73	54p	74C159	£1.10	74C901	54p	74C920	£11.83
74C74	56p	74C161	£1.10	74C902	54p	74C921	£11.83
74C76	54p	74C162	£1.10	74C903	54p	74C922	£3.56
74C83	£1.29	74C163	£1.10	74C904	54p	74C923	£3.73
						74C924	TBA
						74C925	£4.84
						74C926	£4.84
						74C927	£4.84
						74C928	£4.84
						74C929	£11.83

QUARTZ

32.768 KHz	£3.23
100.0 KHz	£3.62
200.0 KHz	£3.92
204.8 KHz	£3.92
262.144 KHz	£3.92
307.2 KHz	£3.92
312.5 KHz	£3.92
453.0 KHz	£3.92
1.000 MHz	£3.62
1.008 MHz	£3.92
1.032 MHz	£3.62
2.000 MHz	£3.62
2.097152 MHz	£3.23
3.000 MHz	£3.62
3.2768 MHz	£3.23
3.579545 MHz	£1.95
4.000 MHz	£2.90
4.032 MHz	£3.23
4.096 MHz	£3.23
4.194304 MHz	£3.23
4.433619 MHz	£1.25
4.608 MHz	£3.23
4.800 MHz	£3.23
4.915 MHz	£3.23
5.000 MHz	£3.23
5.120 MHz	£3.23
5.185 MHz	£3.23
6.000 MHz	£3.23
6.144 MHz	£3.23
6.400 MHz	£3.23
6.55600 MHz	£3.23
7.000 MHz	£3.23
7.168 MHz	£3.23
7.580 MHz	£3.23
7.85432 MHz	£3.23
8.000 MHz	£3.23
8.388008 MHz	£3.23
9.000 MHz	£3.23
10.000 MHz	£3.23
10.700 MHz	£3.23
14.31818 MHz	£3.23
18.000 MHz	£3.23
18.432 MHz	£3.23
20.000 MHz	£3.23
22.1184 MHz	£3.23
27.448 MHz	£3.23
38.666 MHz	£3.23
48.000 MHz	£3.23
100.000 MHz	£3.23
116.500 MHz	£3.23

MICROPROCESSORS

COMPUTER KITS (Check stock before ordering)		
MSK 14	£39.95	
NASCOM 1	£197.50	
MPU I/O		
AY-5103 UART	£4.41	
INS 8154 RAM I/O	£7.50	
6820 PIO	£4.25	
6821 PIO	£4.25	
6850 AOA	£7.17	
81LS 95/6/7/8	£1.36	
ROM SOFTWARE (FIRMWARE)		
MC 6803-2 (Mk-Sup)	£13.70	
5204 (Mk-A) (Mk-Sup)	£14.95	
ROM CHARACTER GENERATORS		
MCN 6571/6576	£6.71	
MK 5002	£15.20	
RO-3-2013	£5.50	
DM 8678 CAR/DM 8678 2W	£74.27	
NEW! YOU-From-TV CHIP		
Thompson CST TV-CAT controller (16 line by 64 characters)	£11.75	
(An ideal companion to MIBL firmware, to turn your TV into a Personal Computer)		
UV Erasable EPROMs		
1702 (256 x 8)	£6.35	
5204 (512 x 8)	£9.95	
2708 (1K x 8)	£9.95	
68708 (1K x 8)	£9.29	
EPROM (not erasable)		
MC 2708P	£5.78	
STATIC RAMs		
6810 (128 x 8)	£3.10	
2101 (256 x 4)	£2.25	
2102 (1K x 1)	£1.20	
2111 (256 x 4)	£1.75	
2112 (256 x 4)	£2.25	
2104 (M)	£1.95	
2114 (1K x 4)	£11.95	
SPECIAL: 280 DATA PACK £13.95		
A set of the following 5 280 data manuals and all the related data we can find of interest to the 280 user:		
280 CPU Technical Manual	£10.00	
280-CTC Product Specifications	£3.50	
280-PIO Technical Manual	£3.50	
280-Programming Manual	£3.50	
280-Micro Retriever Manual	£3.50	
COP 1802 MPU User Manual (RCA)		£4.50
COP 1802 Subroutines (RCA)		£4.50
COSMAC MPU Guide (RCA)		75p
DATA		
Note: In this section all data books are subject to 0% VAT, for postage use 'Terms' at list of page.		
6850 page COSMOS Database (RCA)	£4.95	
6800 page COSMOS Database (Motorola)	£3.50	
'MC 14500B ICU Handbook' (Motorola)	£1.50	
'Understanding Microprocessors' (Motorola)	£2.75	
'A Guide to KITBUS' (Komitran)	£1.00	
'A Guide to SC/MP Programming' (Komitran)	£1.00	
16-page data for INS 8154 (ISP-8A/650) (National)	50p	
20-page data for SC/MP II (National)	50p	
CATALOGUE: Free on request (when available)		
CWO: Add VAT to all prices at 8%, except where stated otherwise		
Post, etc.: UK 25p (+ 2p = 27p) per order. Export add 75p (Europe), £2.50 elsewhere, no VAT		
Polys, universities, gov. depts., etc. can telephone their orders for immediate despatch		
TERMS		
VAT		
GREENBANK ELECTRONICS (Dept. T11E)		
92 New Chester Road, New Ferry, Wirral, Merseyside L62 9AG England. Tel: 051-645 3391		

VEROBORD

Still stocked, please see last month's issue for prices

SOLDERCOM PINS	
100/1000	50p/£3.50
DIL SOCKETS	
8/14/16 pin	10p/12p/13p
24/28/40 pin	36p/40p/50p
TIMER ICs	
NE555/556	29p/49p
OP-AMPS	
(All Minidip)	
CA 3138A	84p
CA 3140E	35p
LM 741 (Texas)	22p
68741 (Texas)	£1.00
LED DISPLAYS	
DL-704E/707E	85p
DL-727E/728E	£2.00
DL-747E/750E	£1.80
FND 500/560	£1.20
LIQUID CRYSTAL DISPLAY	
4 x 0.5" Digits 40 pin DIL	£1.25
4 x 0.5" Digits 40 pin DIL	£8.95
CLOCK CHIPS	
A1-5-1224A	£2.50
MK 50253	£5.50
MK 50382/51036	£5.50
MC 14440 (LDC)	£11.50
SIX DECADE COUNTERS	
MK 50395/4-7	£8.75
MK 50398/9	£8.20
VIDEO	
Add 12% VAT to these items	
OHF Ch. 36 Vision Modulator	£2.50
Olite Wide Bandwidth	£4.70
Sound Modulator	£2.50
TIMEBOX, Digital Clock Case, 56 x 131 x 71.5 mm with red acrylic window. Case colour white. £2.06.	

SINTEL

THE SINTEL SIX DIGIT MAINS CLOCK KIT

with BLEEP ALARM and TOUCH SWITCH SNOOZE

- HIGH BRIGHTNESS DISPLAY
- AUTOMATIC INTENSITY CONTROL
- DEEP RED DISPLAY FILTER
- SLIM WHITE CASE 205mm x 40mm x 140mm
- BATTERY BACKUP
- CRYSTAL CONTROL FOR IMPROVED ACCURACY



Order as **ACK + BK + XTK** £34.50
 The ACK is also available without battery backup and crystal control. Order as **ACK** £28.80
 The kit is supplied complete with the exception of a mains plug, cable and battery

DATABOOKS

BEST OF BYTE Volume 1. 380 pages	£11.95
Illustrating Basic	£2.45
Intel Memory Design Handbook	£5.20
Intel 8080 Microcomputer Systems User's Manual	£6.50
Intel 8085 Microcomputer Systems User's Manual	£6.50
Motorola Booklet From the Computer to the Microprocessor	£1.80
Motorola CMOS Databook (Vol 5 Series B)	£3.50
Motorola M6800 Microprocessor Applications Manual	£12.95
Motorola M6800 Programming Manual	£5.35
National SC/MP Intro Kit User's Manual	£0.75
National SC/MP Technical Description	£1.80
National Semiconductor TTL Databook	£2.10
RCA CMOS and Linear IC Databook	£5.45
Texas Instruments Pin Configuration Guide: A very useful set of glass cards showing top and bottom pin-out views of 7400 ICs plus many others (T1 Memories Op-Amps etc)	£2.95
Z80 Assembly Language Programming Manual	£7.50
Zilog Z80-CPU Technical Manual	£5.60
Zilog Z80 CTC Product Specifications	£0.80
Zilog Z80-P10 Technical Manual	£3.30
DATASHEETS at 75p each on IM6100 6800 SC/MP CDP 1802 2650 TMS5501 TMS8080 9131 Z80vP Intel 8085. Also free data on some components.	

Some Popular Memories available from SINTEL

(See ETI DATA SHEET SPECIAL July 1978)

2102 450 nsec 1K STATIC RAM	£1.85
2102 650 nsec STATIC RAM	£1.85
2708 1K x 8 bit UV ERASABLE ROM	£8.80
6506 600 nsec 1K STATIC RAM	£8.05

ASSEMBLED LATCHED COUNTER MODULES



SIX DIGIT TTL COUNTER MODULE

Our range of Industrial Latched Counter Module Kits is now available ready-built. These counters use both CMOS and TTL ICs and will save you considerable design, purchasing, building and de-bugging time. Each module uses a set of red LED displays and features a single in-line plug and socket. Instructions are provided. For full details please send for Catalogue.

	TTL		CMOS	
	Part No	Built	Part No	Built
2 digit	401-484	£13.22	526-412	£10.52
4 digit	715-484	£23.38	657-412	£17.98
6 digit	293-484	£33.75	721-412	£25.66
			985-568	£13.02
			512-568	£22.63
			393-568	£32.31
			548-470	£10.42
			869-470	£18.11
			191-470	£25.85

NEW PRICES AND SOME NEW CMOS ADDITIONS

If you need your CMOS by return — buy it from SINTEL

CD4000	0.15	CD4027	0.44	CD4051	0.82	CD4086	0.64	CD40182	1.40
CD4001	0.17	CD4028	0.77	CD4052	0.82	CD4089	1.39	CD40192	1.40
CD4002	0.17	CD4029	1.03	CD4053	0.82	CD4093	0.80	CD40193	1.40
CD4006	1.04	CD4030	0.50	CD4054	1.04	CD4094	1.69	CD40194	1.19
CD4007	0.18	CD4031	2.00	CD4055	1.18	CD4095	0.94	CD40257	1.48
CD4008	0.87	CD4032	0.89	CD4056	1.18	CD4096	0.94	CD4502	0.81
CD4009	0.50	CD4033	1.25	CD4059	4.29	CD4097	3.35	CD4510	1.01
CD4010	0.50	CD4034	1.71	CD4060	1.00	CD4098	0.98	CD4511	1.25
CD4011	0.18	CD4035	1.06	CD4063	0.98	CD4099	1.65	CD4514	2.47
CD4012	0.20	CD4036	2.86	CD4066	0.55	CD40100	2.50	CD4515	2.82
CD4013	0.43	CD4037	0.85	CD4067	3.35	CD40101	1.61	CD4516	1.01
CD4014	0.83	CD4038	0.96	CD4068	0.20	CD40102	2.13	CD4518	0.97
CD4015	0.83	CD4039	2.78	CD4069	0.20	CD40103	2.13	CD4520	1.04
CD4016	0.48	CD4040	0.97	CD4070	0.46	CD40104	1.10	CD4527	1.43
CD4017	0.79	CD4041	0.75	CD4071	0.20	CD40105	1.06	CD4532	1.21
CD4018	0.83	CD4042	0.69	CD4072	0.20	CD40106	0.62	CD4555	0.78
CD4019	0.50	CD4043	0.88	CD4073	0.20	CD40107	0.69	CD4556	0.78
CD4020	1.11	CD4044	0.84	CD4075	0.20	CD40108	5.36	MC14528	0.93
CD4021	0.90	CD4045	1.26	CD4076	1.17	CD40109	1.03	MC14553	4.43
CD4022	0.82	CD4046	1.20	CD4077	0.39	CD40160	1.19	IM6508	8.05
CD4023	0.18	CD4047	0.89	CD4078	0.20	CD40161	1.19		
CD4024	0.70	CD4048	0.50	CD4081	0.20	CD40162	1.19		
CD4025	0.20	CD4049	0.50	CD4082	0.20	CD40163	1.19		
CD4026	1.55	CD4050	0.43	CD4085	0.64	CD40181	3.40		

For our full range of components send for Free Catalogue
 Our Offices are at 209 Cowley Road, Oxford, but please do not use this as a postal address
 PRICES VALID UNTIL 31st AUGUST 1978

OFFICIAL ORDERS ARE WELCOME from Companies Govt. Depts Natl. Inds. Univs. Polys.
ORDERS: C.W.O. add VAT @ 8% + 35p p&p TELEPHONE and CREDIT (Invoice) ORDERS add VAT @ 8% + 50p p&p minimum charge (the balance will be charged at cost). Please see FAST SERVICE EXPORT ORDERS welcome, no VAT but add 10% (Europe) 15% (Overseas) for Air Mail p&p. For Export postage rates on heavy items — contact us first.

ORDERS TO: SINTEL, PO BOX 75A, OXFORD
Tel: 0865 49791

FAST SERVICE: We guarantee that Telephone Orders for goods in stock, received by 4.15 p.m. (Mon-Fri.) will be despatched on the same day by 1st Class Post (some heavy items by parcel post) and our stocking is good. Private customers should telephone and pay by giving their Access or Barclaycard number, with a minimum order value of £5. Official orders, no minimum.



electronics today

MAY 1978

45p

ROBOTS

Robot City?

ETI 1978

ETI 1978

ETI 1978

ETI 1978

ETI 1978

ETI 1978

ETI 1978

ETI 1978

ETI 1978

ETI 1978

ETI 1978

ETI 1978

ETI 1978

ETI 1978

ETI 1978

ETI 1978

ETI 1978

ETI 1978

ETI 1978

ETI 1978

ETI 1978

ETI 1978

ETI 1978

ETI 1978

ETI 1978

ETI 1978

ETI 1978

ETI 1978

ETI 1978

ETI 1978

ETI 1978

ETI 1978

ETI 1978

ETI 1978

ETI 1978

ETI 1978

ETI 1978

ETI 1978

ETI 1978

ETI 1978

ETI 1978

ETI 1978

ETI 1978

ETI 1978

ETI 1978

ETI 1978

ETI 1978

ETI 1978

ETI 1978

ETI 1978

ETI 1978

ETI 1978

ETI 1978

ETI 1978

ETI 1978

ETI 1978

ETI 1978

ETI 1978

ETI 1978

ETI 1978

ETI 1978

WHAT A BIND!

Half our orders for binders are repeats: we think that says a lot for their quality. At £3.00 all inc. you get a great deal of peace of mind too!

ETI Binders
 25-27 Oxford Street,
 London W1R 1RF.

TOPS THE PACK!



ACE

COMPONENTS - Now over 1,000 types in stock.
KITS - See the new range of low-cost 'ELEKITS'.
MODULES - New ready-built functions.
SERVICE - 1st Class same day despatch.
QUALITY - All guaranteed products.
PRICES - Many reductions!
MAGAZINE PROJECTS - Trouble-free!

LOOK



ACE MAILTRONIX LTD
 Dept. Tootal Street
 Wakefield, W. Yorkshire WF1 5JR

Our 2nd edition illustrated catalogue is now available. The much increased range shows many welcome price reductions.

INTRODUCING FABULOUS 'ELEKITS'

The new range of easy build kits complete with simple to follow instructions. Battery powered (not supplied). With case.

- * BURGLAR ALARM
- * ROULETTE
- * BICYCLE SOUND FLASHER
- * WATER LEVEL ALARM
- * SIREN
- * BLINKER
- * TIME SWITCH

Easy build introduction to electronics. Many hours of enjoyment. **NOW AVAILABLE!**

Many others in preparation - included in full ACE catalogue - send S.A.E. for free brochure of kit range.



Mini ORGAN

only **£7.95**



MORSE TRAINER

only **£4.95**

PRICES Inc.VAT

I enclose 30p*, please send catalogue.

Name _____
 Address _____

* Refundable with future orders over £5.00.

CHROMASONIC electronics

56 FORTIS GREEN ROAD, MUSWELL HILL, N10 3HN
 TELEPHONE: 01-883 3705

OUR LATEST CATALOGUE

CONTAINS FREE
45 pence WORTH OF VOUCHERS



CONTAINS MICROPROCESSORS + BOARDS, MEMORIES, TTL, CMOS, ICs, PASSIVES, ETC., ETC.

SUPERSAVERS

ALL FULL SPEC DEVICES

TEXAS	TIMER	RED LED
741	555	TIL209
5 for	4 for	10 for
£1.00	£1.00	£1.00
<small>(INC CLIP)</small>		
VAT INCLUSIVE PRICE + 25p P. & P.		

A4 IC BOOKLET

SUPPLIED FREE WITH ORDERS OF ANY ICs WORTH £5.00 OR MORE, CONTAINS CIRCUITS, PIN CONNECTIONS AND DATA (35p + SAE IF SOLD ALONE).

ALL PRICES INCLUDE VAT

FOR SERVICE QUALITY & VALUE

ALL PRICES INCLUDE VAT



RF POWER METER

(ETI project 139 - October '78)
 Most components in stock including
 12.7mm toroid - F14 @ 16p, F25 @ 28p. PCB £1.00.

2 METER POWER AMP

(ETI project 710 - September '76)

This is a simple-to-build, easily-aligned Class C PA suitable for CW and FM amplification at 2 metres from a nominal 13.5V (-ve earth) supply (7 amps at full power). T/R 'switching' is performed by diodes and ¼ wave lines. A power input of 10 watts is required for the nominal 40 watts output power.
Complete with cabinet - £19.50 + 65p p&p.

LOW COST V.D.U.

(ETI project 560 - Aug/Sept/Oct '76)

All components available for this popular low cost V.D.U. project. Complete kit at **Special Price £64.00 + £1.00 p&p**.
 Separate components -
PCB set £7.20; 2112-2, £4.50; 2513, £8.50; 555, 47p.

All prices INCLUDE VAT but please add minimum of 34p for post and packing.
Send SAE for FREE PRICE LIST or 45p + large (A4) 18 ½p SAE for copy of our Data-Catalogue.

TELETEXT DECODERS

From Catronics - the Number One company for Teletext Decoders for CEEFAX and ORACLE. We now offer a wide range starting at below £145.00.

KITS - Based on 'Wireless World' design:
Basic upper case only - £144.50
Standard decoder - £157.25
De-luxe with ALL new facilities - £194.40
 KITS - Based on 'Television' magazine design:
Complete kit (as published) - £220

TIFAX MODULE

special offer including mounting board and interface circuitry plus full application information - **£129.35.**

READY BUILT DECODERS

Prices from £230 to a full specification professional model at £310. Send SAE for full details.

7400 SERIES TTL

All new, full specification, full Guarantees
 Mostly National and Texas products

7400	14p	7421	31p	7483	78p	74145	£1.24	74177	84p
7402	14p	7427	29p	7485	£1.12	74150	£1.07	74180	82p
7403	14p	7428	38p	7486	33p	74153	69p	74188	£3.40
7404	15p	7430	18p	7490	36p	74157	72p	74192	£1.38
7406	40p	7432	27p	7492	52p	74161	80p	74193	£1.38
7408	18p	7440	18p	7493	39p	74164	£1.12	74195	£1.83
7410	15p	7442	75p	7496	87p	74165	£1.12	74196	£1.80
7411	22p	7447	75p	74107	35p	74166	£1.60	74221	£1.75
7412	24p	7473	35p	74121	29p	74170	£2.48	74H00	35p
7414	78p	7474	28p	74123	79p	74174	84p	74H04	44p
7420	17p	7475	48p	74126	81p	74175	94p	74H10	38p

10% DISCOUNT on TTL orders over £20

CATRONICS LTD. (Dept. 851), COMMUNICATIONS HOUSE, 20 WALLINGTON SQUARE, WALLINGTON, SURREY SM6 8RG
 Telephone: 01-669 6700 Open 9 am to 6 pm Mon.-Fri., 9 am to 1 pm Sat. Closed for lunch 12.45 to 1.45 pm

Guitar Sustain Unit

S. D. Maistre

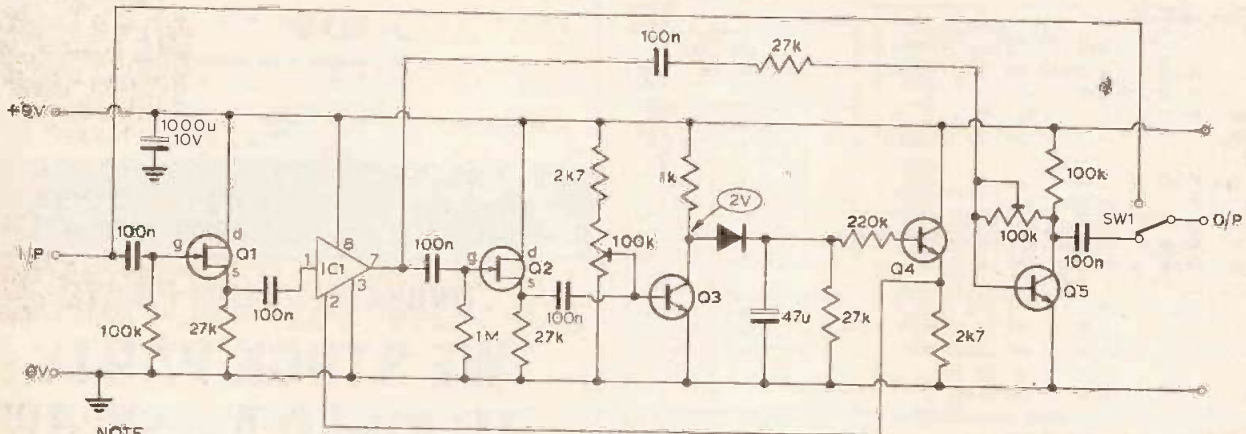

NOTE
Q1, 2 are 2N3819
Q3, 4, 5 are BC109C
D1 is OA91
IC1 is MC3340

The sustain to be described here holds the output at a constant level over a wide range of input levels. It was designed for use with electric guitars and has a maximum effect with the guitar pick-up volume full up.

The principle employed is that of an AGC, whereby the circuit output is monitored by a DC voltage follower which controls the gain of the VCA through which the signal passes. The advantages of this circuit are that, unlike many such devices, it does not use opto-coupling which draws too much current for battery powered equipment; it produces no audible distortion; components are easily obtained — and cost is low.

Construction method is not criti-

Digital Bike Speed

B. Lemming

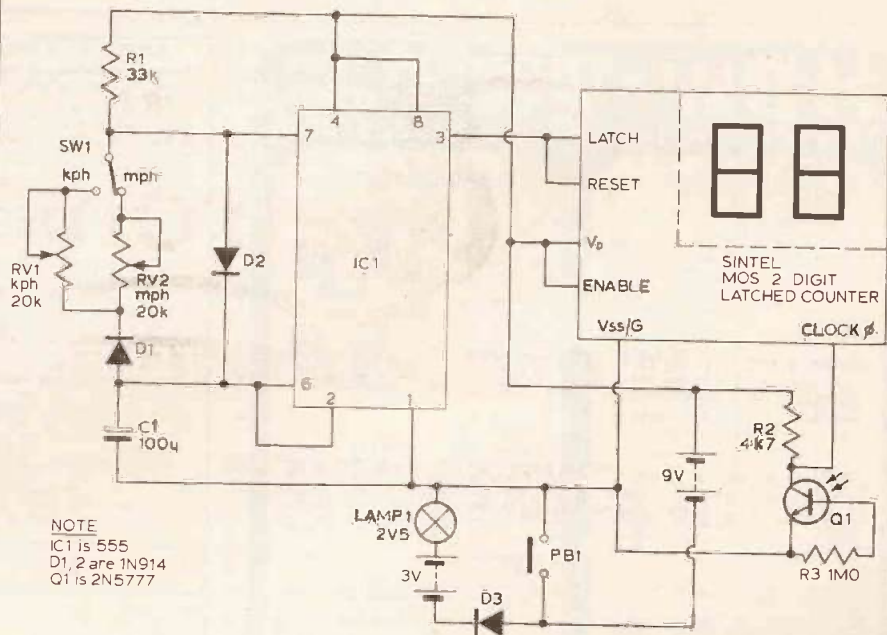

NOTE
IC1 is 555
D1, 2 are 1N914
Q1 is 2N5777

case opposite the lamp so that the barriers interrupt the beam in operation. The counter operates whilst PB1 is pressed, but latches after a time determined by RV1 or RV2. IC1 and associated components. IC1 forms a square-wave oscillator with

variable mark-space ratio. The time for which pin 3 is taken low is determined by RV1/RV2 — this enables the counter.

The speed accuracy is determined by the accuracy of setting of controls RV1 and/or RV2.

This unit provides push-bike speed measurement between zero and 100 km/hr or 100 mph! The circuit is based on the Sintel MOS counter block, which counts the pulses from the photo transistor Q1.

These pulses are provided by a ring 18 aluminium 'barriers' to the wheels. Q1 was an unmarked type in the prototype, in a TO 18 package. This mounts in an old felt-tip pen

Tech-Tips is an ideas forum and is not aimed at the beginner. We regret we cannot answer queries on these items.

ETI is prepared to consider circuits or ideas submitted by readers for this page. All items used will be paid for. Drawings should be as clear as possible and the text should preferably be typed. Circuits must not be subject to copyright. Please for consideration send to: ETI TECH-TIPS, Electronics Today International, 25-27 Oxford St., London WC1B 3PB.

FLADAR DUAL VOLTAGE TRANSFORMERS

PRIMARY 220-240 50HZ.
ALTERNATIVE SECONDARY VOLTAGE AND CURRENT
AVAILABLE BY SERIES OR PARALLEL CONNECTION

Type	Voltage	Current	E	p/p	Type	Voltage	Current	E	p/p
60FE12	12+2	3A EACH	3.60	75p	12FE06	6+6	1A EACH	2.0	60p
60FE15	15+15	2A EACH	3.60	75p	12FE09	9+9	0.75A EACH	2.0	60p
60FE20	20+20	1.5A EACH	3.60	75p	12FE10	10+10	0.6A EACH	2.0	60p
60FE28	28+28	1.1A EACH	3.60	75p	12FE12	12+12	0.5A EACH	2.0	60p
60FE30	30+30	1A EACH	3.60	75p	12FE15	15+15	0.4A EACH	2.0	60p
					12FE20	20+20	0.25A EACH	2.0	60p
50FE12	12+12	2A EACH	3.10	70p	08FE06	6+6	0.6A EACH	1.80	50p
50FE15	15+15	1.6A EACH	3.10	70p	08FE09	9+9	0.5A EACH	1.80	50p
50FE20	20+20	1.2A EACH	3.10	70p	08FE10	10+10	0.4A EACH	1.80	50p
50FE28	28+28	0.9A EACH	3.10	70p	08FE12	12+12	0.3A EACH	1.80	50p
50FE30	30+30	0.8A EACH	3.10	70p	08FE15	15+15	0.25A EACH	1.80	50p
20FE06	6+6	1.6A EACH	2.60	65p	06FE06	6+6	0.5A EACH	1.50	50p
20FE09	9+9	1.0A EACH	2.60	65p	06FE10	10+10	0.35A EACH	1.50	50p
20FE12	12+12	0.8A EACH	2.60	65p	06FE12	12+12	0.25A EACH	1.50	50p
20FE15	15+15	0.6A EACH	2.60	65p	06FE15	15+15	0.20A EACH	1.50	50p
20FE20	20+20	0.5A EACH	2.60	65p	30FE30	0-12-15-20-24-30	1A	2.95	1.00
60FE52	26-0-26	1A EACH	3.60	75p	60FE30	0-12-15-20-24-30	2A	4.70	1.00
60FE50	30-0-30	1A EACH	3.60	75p	100FE30	0-12-15-20-24-30	3A	5.60	1.00
80FE52	26-0-26	1.5A EACH	4.50	75p	100FE60	30-0-30	2	5.10	1.00
80FE60	30-0-30	1.5A EACH	4.50	75p	100FE26	26-0-26	2	4.80	1.00
100FE28	28-0-28	2.0A EACH	4.50	75p					

FLADAR ELECTRIC
P.O. BOX 19
WESTCLIFF-ON-SEA
ESSEX. 0702-613314

TRADE ENQUIRIES
WELCOME

PLEASE ENQUIRE
FOR OTHER TYPES
NOT SHOWN

PAYMENT TERMS:
C.W.O. Cheques,
Postal Orders
Please Add 8% VAT
After post & packing.

HOME COMPUTING NASCOM 1 Build and tested £267.30

Set	Height of King	Price
Chesselot	3	7.30
Military	4 1/2	10.45
Lewis	3 1/2	15.70
British Birds	5	18.95
Reynard the fox	7 1/4	25.00

(as show on cover of
ETI Oct 78)

1/12 Scale R/C Electric Car
Kit Parache de
two channel Escurt
R/C Body
£44.87

4 Digit Alarm Clock chip and
display G1 CK3000 I.C. +
Plasma Display **£4.90**

Microminiature Mercury Tilt
Switch **£1.00**

Universal Mains Adaptor 6:
7 1/2:9V 250ma **£2.90**

Sound Modulator **£2.90**
Vision Modulator **£2.90**
Colour Encoder **£2.90**
Encoder/Vision Mixer **£4.90**

TV GAMES

Programmable TV Game in colour
Main console + mains
adaptor **£38.90**
Cartridge Price
No 1 10 games **FREE**
(with above)
No 2 Stuntrider **£20.25**
No 3 Roadrace **£16.95**
No 4 Tank battle **£23.50**

Hand controls supplied with cartridges

All prices include P&P & VAT

NIC MODELS, 27 Sydney Road, London N22
Other chess set available - 15p illustrated lists

UNBEATABLE LOW PRICES WE STOCK PARTS TO BUILD MUSICAL PROJECTS

As published by leading magazines
Send large s.a.e. for lists

DALSTON ELECTRONICS
40A Dalston Lane
Dalston Junction E8 2AZ
Tel. 01-249 5624

HB ELECTRONICS 22 NEWLAND STREET, KETTERING TELEPHONE, KETTERING 0536 83922 520910

BULK OFFERS

TRANSISTORS	PER 10	PER 100
BC107/8/9	£0.85	£7.50
PBC107/8/9	£0.85	£5.50
BC547/8/9	£0.75	£6.50
BC557/8/9	£0.75	£6.50
BC212/3/4	£0.75	£6.50
BC194/5	£0.80	£7.00
BF199	£1.50	£11.00
BF200	£1.50	£22.00
BFY50/1/2	£1.65	£15.00
TIP31A/2A	£3.20	£30.00
TIP41A/2A	£4.80	£43.00
2N3055 (TO3)	£4.20	£38.50
2N3702/3/4	£0.80	£7.00
2N3819	£1.70	£14.50

DIODES	PER 10	PER 100
1N4001/2/3	£0.48	£3.90
1N4004/5	£0.55	£5.00
1N4007	£0.70	£6.00
1N4148	£0.80	£2.20
Zener Diodes 400mW	£0.75	£5.80

LEDs	PER 10	PER 100
0 2 Red	£0.90	£8.00
0 125 Red	£0.95	£8.00
0 2 Red Flat Sides COX10	£1.60	£15.00
0 2 Yellow/Green	£1.20	£10.00
0 125 Yellow/Green	£1.30	£10.00
0 2 Yellow/Green Flat Sides COX11/12	£2.20	£20.00

ORDERING DETAILS
VAT: Add high rate to items. Standard rate to others.
POST & PACKING: 30p on all orders under £5.00. Otherwise free. Overseas please add freight costs and state surface or air. No VAT on overseas or BEPO orders. All orders sent first class post in heat sealed padded bags.
DELIVERY: All orders processed on day of receipt. Goods offered subject to availability.

BARGAIN PACKS

ICs	PER 10	PER 100
LM324 (14 KIL)	£7.00	£51.00
LM555 (8 DIL)	£2.60	£23.00
LM741 (8 DIL)	£1.80	£15.50

TANT BEADS	PER 10	PER 100
0 1µF 0.22µF 0.47µF 1µF 35V	£0.75	£6.30
2 2µF 35V	£0.95	£8.00
4 7µF 35V	£1.20	£11.00
10µF 35V	£1.50	£12.00
22µF 16V	£1.50	£12.00

HARDWARE	PER 10	PER 100
8 pin DIL Socket	£1.00	£9.00
14 pin DIL Socket	£1.10	£9.50
16 pin DIL Socket	£1.20	£10.00
24 pin DIL Socket	£2.00	£18.00
Mini slide switches	£1.50	£12.00
Mini push to make switches	£1.50	£12.00

RESISTORS	PER 10	PER 100
1/2 Watt Carbon Film (Min Type)	£1.25	per 100
Mixed lots of 100	£10.00	per 1000

MICRO PROCESSORS
Wide range of micro parts stocked. Send for free list or visit our showrooms in Kettering and get hands on experience of the PET2001 in stock now.
(PET 2001 is distributed by our sister company HB Computers)

and our conditions of sale: Cash returned for out of stock items.
PAYMENT: Cash, cheque, postal order. Credit card orders accepted by letter or telephone.
GUARANTEE: All devices are brand new and full spec. No manufacturer's faults or rejects. Any faulty items returned in good condition will be replaced or refunded.
ENQUIRIES: Please enclose a suitable S.A.E.

INES FROM OUR VAST STOCKS - IMMEDIATE DELIVERY

All below manufacturers' prices - all new stocks. Quantity discounts - export enquiries invited.
Postage & packing 35p per order
CALCULATOR CHIPS General instrument GIMT4 on anti static foam 24 pin D.I.L. socket for use with Bowmar display £1.50 ea. Pack of 25 chips £25.
BOWMAR 9 DIGIT CALCULATOR DISPLAY with PC connector 0.2 digit. Common cathode with red bezel **£1.25** 10 - **£10**.
TEXAS 19 gold plated snap key contacts on gold plated P.C. board Size 70x80x2mm **75p** ea 10 for **£6**.
ORP12 light dependent resistance (Eq = RPY30) 2 for **£1**, 10 - **£4**, 100 - **£35**.
FAIRCHILD FND10 0.15 7 segment display cathode **50p** 10 for **£4.50**.
TBA 120A 1 V 1 C amplifier Siemens **75p** 10 - **£6**, 100 - **£50**, 1000 - **£350**.
BECKMAN 900 1cc Trippleable clocking oscillator for use with calculator chips 5v supply with circuit **£1.10** for **£8**.
NURROUGHS 9 0101T Parallax calculator display 7 segment 0.25 digits. Neon type with led bezel socket and data **£2.50** ea 10 for **£20**.
ALMA PUSHBUTTON high reliability reed switches. Push to make 18x27x18mm **40p** ea 10 for **£3.50**.
SMITHS INDUSTRIES Audible warning devices 6-12 volts, 2 transistors 30x10mm encapsulated **80p** ea 10 for **£4.100** for **£30**.
HONEYWELL PROXIMITY DETECTOR integral amplifier 8v D.C. **£2.50** ea 10 for **£20** 100 for **£175**.
OSMOR CHANGE OVER REED RELAY 12v coil 20ma operating current 59x17x13mm **75p** ea 10 for **£5.100** for **£45**.
MAINS TRANSFORMERS (miniature) all with 240v primary.
12 volt 100m/amp: ea 10 **100**
60x40x42 mm **95p** 8' **£60**
12 0.12v 100 m. amp 28x25x27mm **£1.20** **£10** **£80**
Valve output 40 1.61x15x42 mm **£6** **£50**
EL84 output 80x53x34mm **95p** 8' **£65**
SOLDER (multicore type) by Servicol 10 metres for **£1.50** metres for **£4**.
SPEAKERS (miniature) ea per per
2 1/2" 8 ohms **75p** **£6** **£50**
2 1/2" 8 ohms **75p** **£6** **£50**
2 1/2" 40 ohms **75p** **£5** **£40**
CLOCKING OSCILLATOR (Pye Dynamics) 3MHz 3mhz supply 5v 19x25x8mm **85p** 10 for **£7**.
T.V. TUNERS by GEC U.H.F. 38 mcs size 3 1/2" x2 1/4" **£2.50** ea 10 for **£20**.

T.V. SOUND TUNER KIT. Through your F.M. tuner. Kit of parts with instructions **£5.50**. Ready built tested **£7.00**.
JOYSTICK CONTROLS. (Ideal for TV Games, model control). sturdily constructed compact giving full 360° movement and control. Each unit fitted 4 off 100K linear controls **Pair £5.00**.
T/R/L DECODER & F/M TUNER WITH MC1310 DECODER * 5-BUTTON SELECTOR SWITCHES * INPUT SELECTORS FOR GRAM AND TAPE * Supplied complete with FRONT-END TUNER AND FERRITE AERIAL * SIMPLE INTER-CONNECTIONS * Size 19x13x6cm.
THIS QUALITY AMPLIFIER **£10.95** WITH CIRCUIT.
POWER UNIT KIT FOR ABOVE MODELS 25/28 VOLTS £2.95
TAPE HEADS 1/4 track. Record. Marconi XRPS36 **£5**. XES11 erase **£1.25**. XRPS 18 **£3.50**.
MULLARD TUNER MODULES with data LP1171 combined AM/FM IF strip - **£4**. LP1179 FM front and with AM tuning gang used with LP1171 - **£4**. LP1171 and 79 pair - **£6.50**. LP1157 complete AM strip - **£2.05**. * Ferrite Aerial - **95p**.
SEVEN DIGIT MINIATURE COUNTER by Durant 12-24 volts D.C. 3 Watts. Size 40x29HX 55L mm **£1** each. 10 for **£9**. 100 for **£80**.

INDUSTRIAL RELAYS	Price	10	100
By I.M.U. LUMRON At less than Distributor prices 60x40x24V DC 2 Pole Open 60 13 48V AC Octal Plug in type enclosed	£1.10	£9.00	£95.00
60 02 12V AC 2 Pole C Over Dctol Enclosed type	£1.20	£10.00	£90.00
All relays are 250V 6 Amp AC Current Rating	85p	£7.50	£65.00

2N3055A TO3 POWER 80 VOLT VERSION
10 for **£2.50**
100 for **£22.00**
1 000 for **£200.00**
Carriage £2.00 on 1,000 Lots

FREE TRANSISTOR CATALOGUE
SEND STAMPED ADDRESS ENVELOPE FOR YOUR COPY NOW

Buy it with Access **Henry's RADIO** All mail to: Henry's Radio 404 Edgware Rd London W2 Phone 011 723 1008

CMOS Gate Identifier

C. Ching

This circuit can be used to distinguish four types of dual input gates — AND, OR, NAND, NOR — it is also a quick method of checking IC function. If an AND gate is inserted into the socket, an A appears on the LED. An O denotes an OR gate. The decimal point is used to denote inverted function, i.e. .A is an NAND gate.

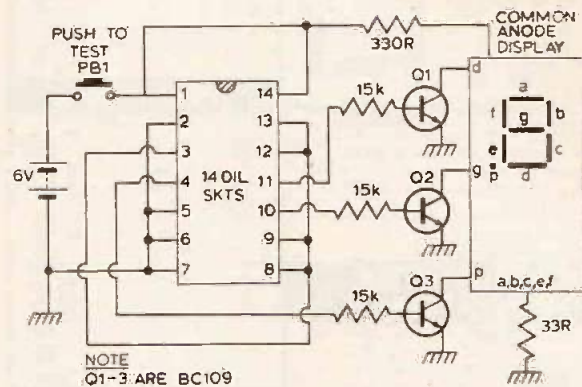

Electronic Ignition Switch

K. A. Last

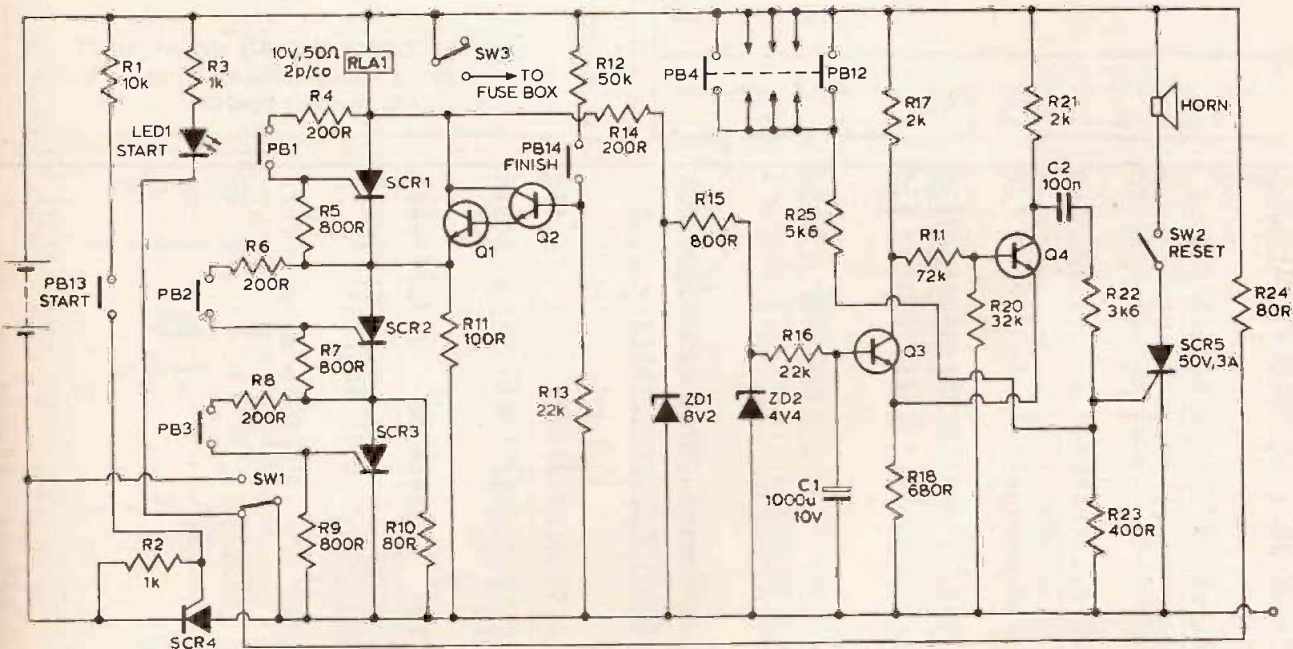

NOTE
 LED1 is BFY50
 Q1, Q2, Q4 are BC108
 Q3 are BC108C
 SCR1-4 50V, 1A TYPES
 SCR5 50V, 3A
 LED2 is TIL 209
 RLA1 is 10V, 50R COIL WITH 2p/co CONTACTS

When used with a calculator type keyboard, this circuit provides a 'combination lock' ignition switch which only activates if the correct sequence of three numbers is keyed in. The keyboard has 14 keys numbered 1 to 12, 'START' and 'FINISH'. To start the car, the 'start' key is pressed and the start LED will light. The correct sequence of 3 numbers is

then keyed in. If the sequence is wrong, the cars horn will be sounded. If the right sequence is entered, the 'START' LED will extinguish and the ignition will be energised. The correct sequence will be PB1, PB2, PB3, but these can be arranged amongst the other keys in the keyboard, and given any numbers.

BAD NEWS FOR KNOB TWIDDLERS

A 300W Lightdimmer with NO knob. Dimming and on/off functions are controlled by touch Features include

- ★ No mains rewiring
- ★ Switches on to preset brightness
- ★ Can be switched and dimmed from many locations using TDE/K kit making 2-way switching easy



★★PRICE £8.99 TDE/K £1.00

LIGHTING CONTROL KITS (300W)

TSD300K TOUCHSWITCH & DIMMER combined One touch-plate for on/off Small knob controls brightness **£5.50**

TS300K TOUCHSWITCH Two touchplates ON/OFF **£4.00**

TSA300K AUTOMATIC One touchplate Preset time delay off **£4.00**

LD300K LIGHTDIMMER **£2.80**

DIGITAL VOLT METER THERMOMETER KIT

Based on the 7106 single IC 3½ digit DVM the kit contains a PCB, resistors, capacitors, presets, IC and 0.5 liquid crystal display. Components are also included to enable the basic DVM kit to be modified to a Digital Thermometer using a single transistor as the sensor



ONLY **£21.99**

24 HR. CLOCK/APPLIANCE TIMER KIT

Switches any appliance of up to 1KW on and off at preset times once a day KIT contains AY-5-1230 Clock/Appliance Timer IC, 0.5 LED display, mains supply display drivers, switches, LEDs, triac, complete with PCBs and full instructions **£13.75**
White box (56x131x71mm)—drilled undrilled **£2.50**



PLEASE ADD 8% V.A.T. (*12½%) TO ABOVE PRICES

QUANTITY DISCOUNTS ON REQUEST ADD 25p POSTAGE & PACKING. MAIL ORDER ONLY TO:

T. K. ELECTRONICS, 106 Studley Grange Road, London W7 2LX

TRIAC BARGAINS

400V Plastic Case	
3A	58p
6.5A with trigger	80p
8A	74p
12A	84p
16A	106p
20A	185p
25A	190p
SCR (C106D) 5A/400V	50p
Diac	21p

COMPONENTS

0.2" L.E.D.S.	
Red 12p	£1/10
Green 21p, Yellow	25p
DL727 5 display	£1.50
LCD 5 4 digit	£9.00
LDR 5 dia	
NE555 (4 for £1.00)	
741 (5 for £1.00)	
LM3911 temperature IC	£1.00
AY-5-1224	£3.25
AY-5-1230	£4.85
ZN1034E	£1.80
ICL7106 DVM IC	£9.25
1N4001	6p
1N4148	4p
8C182L	10p
2N3819	20p

MINI MAINS TRANSFORMERS

Standard 240V mains primary 100mA secondary	
6-0-6V	85p
9-0-9V	90p
12-0-12V	95p

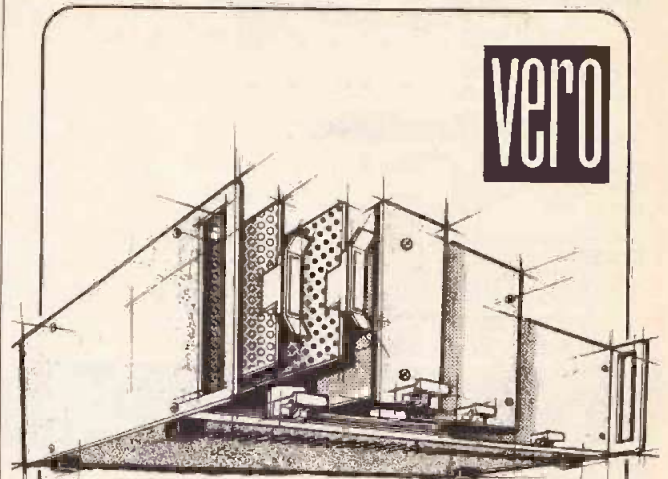

Our new 1978 catalogue lists a card frame system that's ideal for all your module projects — they used it in the ETI System 68 Computer. And we've got circuit boards, accessories, cases and boxes — everything you need to give your equipment the quality you demand. Send 25p to cover post and packing, and the catalogue's yours.

VERO ELECTRONICS LTD. RETAIL DEPT.
Industrial Estate, Chandlers Ford, Hants. SO5 3ZR
Telephone Chandlers Ford (04215) 2956

TRANSISTORS	BC328 15p	BU208 160p	2N4061 12p	7490 32p	74194 92p	4501 19p	DIODES	ZENER DIODES 400mW	10p
AC126 18p	BC338 15p	OC25 76p	2N4062 20p	7491 65p	74195 85p	4507 59p	BY127 16p	2.7V to 33V	
AC127 17p	BC547 11p	OC28 108p	2N4123 23p	7492 45p	74196 92p	4510 110p	0A47 10p	VERO BOARDS 0.1" copper	
AC128 16p	BC548 10p	OC35 108p		7493 34p	74197 92p	4516 110p	0A81 15p	2.5" x 5"	57p
AC141 24p	BC549 11p	OC71 19p		7494 80p	74198 150p	4518 75p	0A200 6p	3.75" x 5"	67p
AC142 24p	BC557 14p	OC72 34p		7495 55p	74199 150p	4519 60p	0A202 9p		
AC151 42p	BCY30 67p	OC84 46p	TTL	7496 62p		4520 110p	0A202 9p		
AC152 53p	BCY34 74p	TIP29 40p	7490 12p	7497 240p	CMOS	4528 107p	1N914 4p	CERAMIC CAP 50V	
AC153 58p	BCY59 24p	TIP30 40p	7401 12p	74100 95p	4000 15p	4528 107p	1N916 5p	22pF to 4700pF	2p
AC176 18p	BCY70 14p	TIP31 50p	7402 12p	74104 50p	4001 15p	4528 107p	1N4001 4p	POLYESTER CAP 250V	
AC187 23p	BCY71 14p	TIP32 55p	7403 12p	74105 40p	4002 16p	4528 107p	1N4002 4p	0.1, 0.15, 0.22, 0.33, 0.47, 0.68, 1 uF	5p
AC188 23p	BD115 52p	TIP33 75p	7404 13p	74107 28p	4006 110p	4528 107p	1N4003 6p	15, 22, 33	7p
AD149 65p	BD121 79p	TIP34 98p	7405 13p	74109 45p	4007 16p	4528 107p	1N4004 7p	47, 68 uF	13p
AD161 38p	BD123 79p	TIP35A 253p	7406 29p	74110 46p	4008 94p	4528 107p	1N4005 10p	1 uF	7p
AD162 38p	BD124 97p	TIP36A 389p	7407 29p	74116 160p	4009 46p	4528 107p	1N4006 10p	15, 22, 33	7p
AF114 30p	BD131 35p	TIP41A 59p	7408 14p	74118 82p	4010 50p	4528 107p	1N4007 11p	47, 68 uF	13p
AF118 30p	BD132 35p	TIP42A 59p	7409 14p	74120 125p	4011 15p	4528 107p	1N4008 16p	2.2 uF	28p
AF125 27p	BD135 38p	TIP2955 126p	7410 12p	74121 26p	4012 16p	4528 107p	1N4009 6p	6.8 uF	48p
AF126 27p	BD136 36p	TIP3055 64p	7411 19p	74122 55p	4013 108p	4528 107p	1N4010 7p		
AF127 27p	BD137 38p	ZTX108 14p	7412 21p	74123 40p	4014 108p	4528 107p	1N4011 8p	ELECTROLYTIC CAP 25V	
AF139 36p	BD138 38p	ZTX109 14p	7413 25p	74125 45p	4015 108p	4528 107p	1N4012 8p	1 uF to 47 uF	7p
AF186 54p	BD139 35p	ZTX300 16p	7414 54p	74126 46p	4016 45p	4528 107p	1N4013 8p	68uF, 100uF	8p
AF239 40p	BD140 35p	ZTX500 16p	7416 27p	74132 70p	4017 65p	4528 107p	1N4014 7p	150uF	9p
ASV53 81p	BF115 25p	2N706 13p	7417 27p	74136 79p	4018 90p	4528 107p	1N4015 7p	330uF	10p
ASV54 81p	BF167 29p	2N1131 23p	7420 12p	74141 56p	4019 65p	4528 107p	1N4016 7p	470uF	12p
ASV55 69p	BF173 27p	2N1132 23p	7421 28p	74142 202p	4020 95p	4528 107p	1N4017 7p		15p
BC107 8p	BF178 34p	2N1302 38p	7422 18p	74145 65p	4021 85p	4528 107p	1N4018 7p	BRIDGE RECTIFIERS	
BC108 8p	BF179 37p	2N1304 54p	7423 25p	74147 135p	4022 85p	4528 107p	1A/50V 28p	1A/100V 24p	
BC109 8p	BF180 37p	2N1305 25p	7424 34p	74148 120p	4023 15p	4528 107p	1A/200V 38p	1A/200V 27p	
BC113 17p	BF181 37p	2N1306 39p	7430 12p	74150 70p	CMOS	4528 107p	1A/400V 40p	1A/400V 30p	
BC117 20p	BF182 37p	2N1308 40p	7432 24p	74151 50p	6000 68p	4528 107p	1A/50V 28p	1A/50V 24p	
BC119 29p	BF183 37p	2N1613 22p	7433 32p	74153 60p	4024 15p	4528 107p	1A/100V 30p	1A/200V 27p	
BC140 34p	BF184 28p	2N1711 21p	7437 24p	74154 106p	4025 35p	4528 107p	1A/200V 38p	1A/200V 27p	
BC142 27p	BF185 30p	2N1893 44p	7438 24p	74155 63p	4027 70p	4528 107p	1A/400V 40p	1A/400V 30p	
BC143 27p	BF194 13p	2N2217 27p	7440 13p	74156 63p	4028 70p	4528 107p	2A/50V 34p	2A/50V 34p	
BC147 7p	BF196 13p	2N2219 21p	7441 52p	74157 63p	4029 90p	4528 107p	3A/200V 38p	3A/200V 36p	
BC149 8p	BF197 16p	2N2369 16p	7442 45p	74160 80p	4030 130p	4528 107p	3A/400V 51p	2A/100V 36p	
BC157 9p	BF198 16p	2N2483 26p	7443 90p	74161 80p	4031 87p	4528 107p	LINEARS	2A/100V 36p	
BC158 9p	BF200 36p	2N2484 22p	7444 90p	74162 80p	4032 75p	4528 107p	710CM 41p	2A/200V 38p	
BC159 9p	BF224 16p	2N2905 22p	7445 70p	74163 80p	4043 85p	4528 107p	1A/50V 28p	2A/400V 40p	
BC168 8p	BF257 37p	2N2906 22p	7446 70p	74164 70p	4044 96p	4528 107p	1A/100V 30p	1A/100V 24p	
BC170 9p	BF258 40p	2N2907 22p	7447 55p	74165 90p	4045 96p	4528 107p	1A/400V 40p	1A/400V 30p	
BC172 9p	BF259 44p	2N2926 10p	7448 58p	74166 100p	4047 63p	4528 107p	3A/100V 36p	3A/100V 34p	
BC173 9p	BF259 44p	2N2926 10p	7449 14p	74167 40p	4048 63p	4528 107p	3A/200V 38p	3A/200V 36p	
BC182 10p	BF259 44p	2N2926 10p	7450 14p	74168 120p	4049 40p	4528 107p	3A/400V 51p	2A/100V 36p	
BC183 10p	BF259 44p	2N2926 10p	7451 14p	74173 120p	4050 40p	4528 107p	OPTO/DISPLAYS	2A/100V 36p	
BC184 10p	BF259 44p	2N2926 10p	7452 13p	74174 90p	4051 40p	4528 107p	2N5777 50p	2A/200V 38p	
BC186 23p	BF259 44p	2N2926 10p	7453 19p	74175 70p	4052 40p	4528 107p	OC71 70p	2A/400V 40p	
BC187 26p	BF259 44p	2N2926 10p	7454 14p	74176 90p	4053 40p	4528 107p	ORP12 90p	RESISTORS 0.25W	
BC207 13p	BF259 44p	2N2926 10p	7455 14p	74177 90p	4054 16p	4528 107p	DL704 90p	4.7 ohms to 1 Mohm	1p
BC212 10p	BF259 44p	2N2926 10p	7456 28p	74178 120p	4055 16p	4528 107p	DL707 90p	POTENTIOMETERS (carbon)	
BC213 10p	BF259 44p	2N2926 10p	7457 25p	74179 120p	4056 16p	4528 107p	LEO 3/5mm 75p	1 Kohm to 2 Mohms log/linear	26p
BC214 10p	BF259 44p	2N2926 10p	7458 48p	74180 120p	4057 16p	4528 107p	Red 10p	5 Kohm to 1 Mohm log switched	60p
BC237 14p	BF259 44p	2N2926 10p	7459 28p	74181 195p	4058 16p	4528 107p	Yellow 17p	PRESETS 0.1W horizontal	
BC238 14p	BF259 44p	2N2926 10p	7460 46p	74182 75p	4059 16p	4528 107p	Green 17p	100 ohm to 1 Mohm	5p
BC301 30p	BF259 44p	2N2926 10p	7461 90p	74183 75p	4060 16p	4528 107p	Clip 3p	TRANSFORMERS 240V primary	
BC303 30p	BF259 44p	2N2926 10p	7462 26p	74184 243p	4061 16p	4528 107p	6-0-5V 100mA 95p	6-0-5V 100mA 360p	
			7463 8p	74185 72p	4062 16p	4528 107p	0.6VX2 1AX2 250p	9-0-9V 100mA 290p	
			7464 8p	74186 72p	4063 16p	4528 107p	9-0-9V 1A 400p	9-0-9V 2A 370p	
			7465 8p	74187 100p	4064 16p	4528 107p	0-12V 2A 370p	0-12V 2A 370p	
			7466 8p	74188 100p	4065 24p	4528 107p	0-15VX2 200mA X2 240p		
				74189 110p					

Add 25p for p&p All items new and full spec

DELTA TECH & CO.
62 NAYLOR ROAD, LONDON, N20 0HN

DIODES/ZENERS

1N914	100v	10mA	.05
1N4005	600v	1A	.08
1N4007	1000v	1A	.15
1N4148	75v	10mA	.05
1N4733	5.1v	1 W Zener	.25
1N753A	6.2v	500 mW Zener	.25
1N758A	10v	"	.25
1N759A	12v	"	.25
1N5243	13v	"	.25
1N5244B	14v	"	.25
1N5245B	15v	"	.25

SOCKETS/BRIDGES

8-pin pcb	.20	ww	.35
14-pin pcb	.20	ww	.40
16-pin pcb	.20	ww	.40
18-pin pcb	.25	ww	.75
22-pin pcb	.35	ww	.95
24-pin pcb	.35	ww	.95
28-pin pcb	.45	ww	1.25
40-pin pcb	.50	ww	1.25
Molex pins	.01	To-3 Sockets	.25
2 Amp Bridge		100-prv	.95
25 Amp Bridge		200-prv	1.95

TRANSISTORS, LEDS, etc.

2N2222	NPN (2N2222 Plastic .10)	.15
2N2907	PNP	.15
2N3906	PNP (Plastic - Unmarked)	.10
2N3904	NPN (Plastic - Unmarked)	.10
2N3054	NPN	.35
2N3055	NPN 15A 60v	.50
T1P125	PNP Darlington	.35
LED Green, Red, Clear, Yellow		.15
D.L.747	7 seg 5/8" High com-anode	1.95
MAN72	7 seg com-anode (Red)	1.25
MAN3610	7 seg com-anode (Orange)	1.25
MAN82A	7 seg com-anode (Yellow)	1.25
MAN74A	7 seg com-cathode (Red)	1.50
FND359	7 seg com-cathode (Red)	1.25

C MOS

4000	.15
4001	.15
4002	.20
4004	3.95
4006	.95
4007	.20
4008	.75
4009	.35
4010	.35
4011	.20
4012	.20
4013	.40
4014	.75
4015	.75
4016	.35
4017	.75
4018	.75
4019	.35
4020	.85
4021	.75
4022	.75
4023	.20
4024	.75
4025	.20
4026	1.95
4027	.35
4028	.75
4030	.35
4033	1.50
4034	2.45
4035	.75
4040	.75
4041	.69
4042	.65
4043	.50
4044	.65
4046	1.25
4049	.45
4050	.45
4066	.55

7400	.10
7401	.15
7402	.15
7403	.15
7404	.10
7405	.25
7406	.25
7407	.55
7408	.15
7409	.15
7410	.15
7411	.25
7412	.25
7413	.25
7414	.75
7416	.25
7417	.40
7420	.15
7426	.25
7427	.25
7430	.15
7432	.20
7437	.20
7438	.20
7440	.20
7441	1.15
7442	.45
7443	.45
7444	.45
7445	.65
7446	.70
7447	.70
7448	.50
7450	.25
7451	.25
7453	.20
7454	.25
7460	.40
7470	.45
7472	.40

7473	.25
7474	.30
7475	.35
7476	.40
7480	.55
7481	.75
7483	.75
7485	.55
7486	.25
7489	1.05
7490	.45
7491	.70
7492	.45
7493	.35
7494	.75
7495	.60
7496	.80
74100	1.15
74107	.25
74121	.35
74122	.55
74123	.35
74125	.45
74126	.35
74132	.75
74141	.90
74150	.85
74151	.65
74153	.75
74154	.95
74156	.70
74157	.65
74161	.55
74163	.85
74164	.60
74165	1.10
74166	1.25
74175	.80

- T T L -

74176	.85
74180	.55
74181	2.25
74182	.75
74190	1.25
74191	.95
74192	.75
74193	.85
74194	.95
74195	.95
74196	.95
74197	.95
74198	1.45
74221	1.00
74367	.75
75108A	.35
75491	.50
75492	.50
74H00	.15
74H01	.20
74H04	.20
74H05	.20
74H08	.35
74H10	.35
74H11	.25
74H15	.45
74H20	.25
74H21	.25
74H22	.40
74H30	.20
74H40	.25
74H50	.25
74H51	.25
74H52	.15
74H53J	.25
74H55	.20

74H72	.35
74H101	.75
74H103	.55
74H106	.95
74L00	.25
74L02	.20
74L03	.25
74L04	.30
74L10	.20
74L20	.35
74L30	.45
74L47	1.95
74L51	.45
74L55	.65
74L72	.45
74L73	.40
74L74	.45
74L75	.55
74L93	.55
74L123	.85
74S00	.35
74S02	.35
74S03	.25
74S04	.25
74S05	.35
74S08	.35
74S10	.35
74S11	.35
74S20	.25
74S40	.20
74S50	.20
74S51	.25
74S64	.15
74S74	.35
74S112	.60
74S114	.65

74S133	.40
74S140	.55
74S151	.30
74S153	.35
74S157	.75
74S158	.30
74S194	1.05
74S257 (8123)	1.05
74LS00	.20
74LS01	.20
74LS02	.20
74LS04	.20
74LS05	.25
74LS08	.25
74LS09	.25
74LS10	.25
74LS11	.25
74LS20	.20
74LS21	.25
74LS22	.25
74LS32	.25
74LS37	.25
74LS38	.35
74LS40	.30
74LS42	.65
74LS51	.35
74LS74	.35
74LS86	.35
74LS90	.55
74LS93	.55
74LS107	.40
74LS123	1.00
74LS151	.75
74LS153	.75
74LS157	.75
74LS164	1.00
74LS193	.95
74LS367	.75
74LS368	.65

1069/74 C04

4071	.25
4081	.30
4082	.30
1C 14409	14.50
1C 14419	4.85
4511	.95
74C151	1.90

MCT2	.95
8038	3.95
LM201	.75
LM301	.45
LM308 (Mini)	.95
LM309H	.65
LM309K (340K-5)	.85
LM310	.85
LM311D (Mini)	.75
LM318 (Mini)	1.75
LM320K5(7905)	1.65
LM320K12	1.65

LINEARS, REGULATORS, etc.

LM320T5	1.65
LM320T12	1.65
LM320T15	1.65
LM324N	1.25
LM339	.75
7805 (340T5)	.95
LM340T12	.95
LM340T15	.95
LM340T18	.95
LM340T24	.95
LM340K12	1.25
LM340K15	1.25
LM340K18	1.25
LM340K24	1.25
78L05	.75
78L12	.75
78L15	.75
78M05	.75
LM373	2.95
LM380 (8-14 PIN)	.95
LM709 (8,14 PIN)	.25
LM711	.45

LM723	.40
LM725N	2.50
LM739	1.50
LM741 (8-14)	.25
LM747	1.10
LM1307	1.25
LM1458	.65
LM3900	.50
LM75451	.65
NE555	.35
NE556	.85
NE565	.95
NE566	1.25
NE567	.95

9000 SERIES

9301	.85	95H03	1.10
9309	.35	9601	.20
9322	.65	9602	.45

MEMO'S, RAMS, CPU'S, E-PROMS

8214	8.95
8224	3.25
8228	6.00
8251	8.50
8255	10.50
8T13	1.50
8T23	1.50
8T24	2.00
8T97	1.00
2107B-4	4.95
2708	9.50
Z80 PIO	8.50
8.95	
2.95	

INTEGRATED CIRCUITS UNLIMITED

7889 Clairemont Mesa Blvd., San Diego, CA 92111 U.S.A.

No Minimum

All prices in U.S. dollars. Please add postage to cover method of shipping. Orders over \$100 (U.S.) will be shipped air no charge.

Payment should be submitted with order in U.S. dollars.

All IC's Prime/Guaranteed. All orders shipped same day received.

SPECIAL DISCOUNTS

Total Order	Deduct
\$35 - \$99	10%
\$100 - \$300	15%
\$301 - \$1000	20%

Phone (714) 278-4394

BarclayCard / Access / American Express / BankAmericard / Visa / MasterCard

IN4148 Diodes by ITT/Texas. 100 for **£1.50**. These are full spec. devices.

Unencoded Hexadecimal 19 keyboard 1-10 ABCDEF. 2 optional keys. Shift key. **£12.50**.

MM2102 AN-4L 1024 x 1 Bit. 450 nano sec. Static Ram. **£1.00** each

FND500 Seven Segment Common Cathode Display **£1.30** each. 4/**£5.00**.

AY5-1013 UART/T **£6.00**.

Red Leds 01.125" or 0.2" 10 for **£1.20**. 100/**£9.00**.

2112 256 x 4 Bit Static Ram 450 nanosec. **£2.95** each. 4/**£11.60**. 8/**£22.60**.

Murata Ultrasonic Transducer **£2.50** each. **£4.00** pair.

741 Op Amp **25p** each. 10/**£2.00**.

555 Timer. **28p** each. 10/**£2.50**.

4001	14p	4029	110p
4007	16p	4047	100p
4011	14p	4049	40p
4012	14p	4060	120p
4013	50p	4066	55p
4015	90p	4069	20p
4106	40p	4071	16p
4017	90p	4072	16p
4020	100p	4081	16p
4022	90p	4082	16p
4023	16p	4510	120p
4024	65p	4511	150p
4025	16p	4516	110p
4026	160p	4518	130p
4027	50p	4528	100p
4028	90p		

Prices include Post and VAT

T. POWELL
306 ST. PAUL'S ROAD, HIGHBURY
CORNER, LONDON N.1. Tel. 01-226 1489

Callers welcome

24 hr. Ansaphone order service
with ACCESS or BARCLAYCARD No

THE SINCLAIR PDM35 digital Multimeter



Now a digital multi-meter at an analogue price and look at the spec!

D.C. VOLTS 1mV-1000V (1% - 1 count) 10mQ input

A.C. VOLTS 1v-500v 40Hz-5kHz (1% + 2 counts)

D.C. CURRENT 1 inA-200mA (1% count)

RESISTANCE 1Q-20mQ (1.5% + 1 count)

£27.95 cash with order or £29.95 company purchase order

A.C. Mains adaptor **£3.95**
deluxe padded carrying case **£3.20**
30kV probe **£18.64**

THE SINCLAIR MICROVISION



The amazing pocket T.V. that will pick up programs throughout the world, complete with rechargeable batteries

£189.95 inc. VAT
Sae (for detailed Brochure ex-stock)

SINCLAIR OM235



Portable 3 1/2 digit 6 function Multimeter

DC volts 1mV to 1000V
AC volts 1mV to 750V
AC & DC current 1uA to 1A
Resistance 1Q to 20mQ
Diode test 0.1uA to 1mA
10mQ input, DC acc: 1.0% AC acc: 1.5% 30Hz-10KHz

Cash with order **£52.80** inc. VAT or £53.70 on company purchase order

A full range of optional accessories. (Prices include VAT)

DM 235 meter complete with test leads and probes **£52.80**
Eveready carrying case with lead storage compartment **£8.95**
Rechargeable battery units **£8.50**. AC adaptor/charger 240V 50 Hz **£3.75**. 30kV voltage probe **£18.04**

We accept govt. / company purchase orders on all goods

KRAMER & CO

We will match any lower advertised price on a cash with order basis if competitor has goods in stock

9 October Place, Holders Hill Road, London NW14 1EJ
Telex 888941 Attn. Kramer K7. Tel. 01-203 2473
Mail order only. SAE for data sheets. Export enquiries welcome

INTER-LOCKING PLASTIC STORAGE DRAWERS



NEVER AGAIN! THROTTLE DISCOUNT PRICES

Newest neatest systems ever devised for storing small parts and components

resistors, capacitors, diodes, transistors, etc. Rigid plastic units interlock together in vertical and horizontal combinations. Transparent plastic drawers have label slots. 1D and 2D have space dividers. Build up to any size cabinet for wall, bench or table top

5 SIZES ALL INTERLOCK

As supplied to Post Office, Industry and Government Depts.

SINGLE UNITS (1D)
(5in x 2 1/4in x 2 1/4in) **£3.50** DOZEN

DOUBLE UNITS (2D)
(5in x 4 1/2in x 2 1/4in) **£5.50** DOZEN

TREBLE (3D) £5.50 for 8

DOUBLE TREBLE 2 drawers. In one outer case (6D2) **£7.90** for 8

EXTRA LARGE SIZE (6D1) £6.90 for 8

PLUS QUANTITY DISCOUNTS

Orders over £20, less 5%. Orders over £60 less 7 1/2%
PACKING, POSTAGE, GARRIAGE. Add £1.00 to all orders under £10. Orders £10 and over please add 10% carriage.

QUOTATIONS FOR LARGER QUANTITIES
Please add 8% V.A.T. to total remittance
All prices correct at time of going to press

4-WAY IN-LINE POWER PANEL



13 AMP PATENT CABLE LOCK
NEON INDICATOR LAMP
EASILY ACCESSIBLE FUSE
MOUNT IT OR TRAIL IT!

Modern slim-line power panel countless uses in home office factory showrooms. Perfectly safe, unbeatable. Can be mounted on wall or trailed anywhere in room. Heat rubber base. Smart PVC outer cover. **Black £3.10**, **White £3.30**, P&P 60p each. State cable length required. 20p per yard

FLAIRLINE SUPPLIES (Dept. ET20)
124 Cricklewood Broadway, London N.W.2
Telephone 01-450 4844

BLOB BOARD BUILDS BETTER PROJECTS CHEAPER, FASTER & BEAUTIFULLY BLOB-BOARD

Blob-Board is now available in many different layouts and sizes to allow the home constructor to build any project from the most simple to the most complicated without the need of layout drawings or having to work out complex component patterns.

Blob-Boards are normally much cheaper than existing matrix boards and do not need any cutting or breaking of contact rails.

The roller tinned tracks and letter number identification of holes make soldering so much easier than non-tinned copper boards and make transferring from circuit diagram to Blob-Board virtually error free.

Components can be re-used and resoldered making circuit project modifications and amendments fast and cheap.

All Blob-Board packs contain step-by-step instructions of how to build projects and a project booklet. The "IC" range has a 20 project booklet with easy to follow circuit diagrams and the "D" range has a 9 project booklet including Radio Receiver, Radio Microphone, Light Operation Switch etc.

IC Range

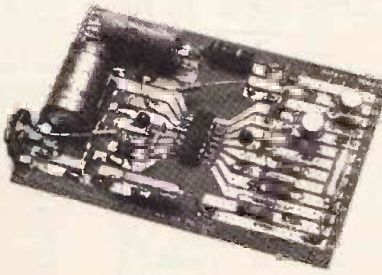

Bred circuit board BCB4 with project

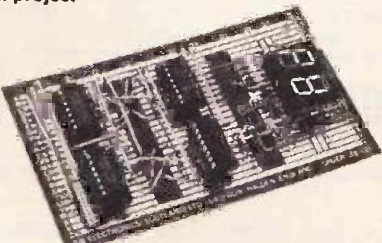

CODE	SIZE mm	PRICE
ZB5D	92 x 61	£0.44
ZB6D	61 x 186	£0.85
ZB7D	125 x 186	£1.67
ZB8D	165 x 241	£2.88
ZB1 IC	114 x 76	£0.66
ZB2 IC	115 x 78	£0.71
ZB4 IC	127 x 203	£1.90
ZB8 IC	254 x 203	£3.69
BCB 1	120 x 150	£1.03
BCB 2	175 x 65	£0.63
BCB 3	125 x 75	£0.54
BCB 4	125 x 50	£0.49
ZB4V	229 x 165	£2.55
ZB4V5	229 x 165	£2.55



PB Electronics (Scotland) Ltd
9 Radwinter Road
Saffron Walden, Essex CB11 3HU

All prices include VAT
Please add 35p p & p minimum order **£3.00**
Available from all good component stockists

O.S.T.S. now from ambit international

Ambit stoppress...news on items available...KV1218 stereo AM tuning decoder with 2.5x bias only £2.75...DT1200 Digital frequency readout module 911223 ultra low THD/IMD mpX decoder module £3.50...MVC1200 stereo MPX decoder with post decoder muting and pilot cancel £19.95..... VMOS

COUNTER ATTRACTIONS:

New this month from Intersil, the ICM 7216. This is probably the most significant new IC for frequency counter/timer applications ever devised. It drives a full 8 digit display (LED) and operates on inputs of up to 10MHz minimum. The price 28 pin DIP and test socket is £1.92, and the 10MHz HC18U Xtal £2.50 (for immediate delivery).
 *Leading zero blanking *Frequency ratio *Period *Unit counter *Time interval *Percentage
 The IC costs £1.92, and the 10MHz HC18U Xtal £2.50 (for immediate delivery).
 The circuit data is free with the IC, or £1 purchased separately.
 New from Ambit is the MC3357. 6v, 2mA standby NB/FM detector and squarer with 10.7 - 465 kHz balanced mixer, on board oscillator device and SSB demodulator. It is ideally suited to our CFM and LFY filter series, and costs £3.72 with test data. £2.50.
 Please note that OSTS prices exclude VAT at 8% throughout this special message. Most ambit items are at 12% except those marked *.

CD4000 CMOS Micromarket PRICES SLASHED

Part No.	Price	Part No.	Price	Part No.	Price
4000	17p	4059	563p	4522	149p
4001	17p	4060	115p	4527	157p
4002	17p	4063	109p	4528	102p
4006	109p	4066	53p	4529	141p
4007	80p	4067	400p	4530	90p
4008	80p	4068	25p	4531	141p
4009	58p	4069	20p	4532	125p
4010	58p	4070	20p	4534	614p
4011	17p	4071	20p	4536	380p
4012	17p	4072	20p	4538	150p
4013	55p	4073	20p	4539	110p
4016	52p	4075	20p	4541	141p
4017	80p	4076	90p	4543	174p
4018	80p	4077	20p	4549	399p
4019	60p	4078	20p	4553	440p
4020	93p	4081	20p	4554	153p
4021	82p	4082	20p	4556	77p
4022	90p	4085	82p	4557	386p
4023	17p	4086	82p	4558	117p
4024	76p	4089	150p	4559	368p
4025	17p	4093	50p	4560	27p
4026	180p	4094	190p	4561	35p
4027	55p	4096	105p	4562	530p
4028	72p	4097	372p	4566	158p
4029	100p	4098	110p	4568	281p
4030	58p	4099	122p	4569	303p
4031	250p	4160	90p	4572	75p
4032	100p	4161	90p	4580	500p
4033	140p	4162	90p	4581	176p
4034	200p	4163	90p	4582	164p
4035	120p	4174	104p	4583	54p
4036	250p	4175	95p	4584	63p
4037	100p	4194	95p	4585	100p
4038	105p	4501	23p		
4039	250p	4502	91p		
4040	83p	4503	65p		
4041	80p	4506	51p		
4042	85p	4507	55p		
4043	85p	4508	248p		
4044	80p	4510	99p		
4045	150p	4511	149p		
4046	130p	4512	98p		
4047	99p	4513	205p		
4048	60p	4514	260p		
4049	55p	4515	306p		
4050	55p	4516	125p		
4051	65p	4517	382p		
4052	65p	4518	403p		
4053	65p	4519	57p		
4054	170p	4520	109p		
4055	135p	4521	236p		

Voltage Regs

NEW LOW PRICES

7805 series UC TO220 package 1A all 95p
 7900 series UC TO220 package 1A all £1
 7810 series UC TO220 package 1/2A all 90p
 78L05 series TO92 100mA all 35p

L200 up to 3A adjustable V&A 195p
 78MGT2C 3A adjustable volts 175p
 78MGT2C 5A adjustable volts 175p
 723C precision controller 65p

MAJNS FILTERS FOR NOISE/RFI etc

1 amp in IEC connector £4.83
 5 amp in 'wire in' case £3.87
 RESSCA 73p

LINEARS non-consumer

Part No.	Price	Part No.	Price
LM224N	71p	LM338N	60p
LM338N	60p	LM348N	186p
LM348N	186p	LM3900N	60p
LM3900N	60p	709HC to5	64p
709HC to5	64p	709P di	36p
709P di	36p	710MC to5	65p
710MC to5	65p	710PC di	59p
710PC di	59p	723CN	65p
723CN	65p	741C4 to5	66p
741C4 to5	66p	747CN	70p
747CN	70p	748CN	36p
748CN	36p	NE531T	120p
NE531T	120p	NE531N	105p

OPTO 7 seg displays

0.43" High Efficiency HP:

5082-7650	red CC	
5082-7653	red CA	
5082-7660	yellow CA	233p
5082-7663	yellow CC	
5082-7670	green CA	
5082-7673	green CC	

0.3" Standard HP

5082-7730	red CA	
5082-7740	red CC	147p

0.5" Fairchild

FND500	red CC	150p
FND507	red CA	150p

TTL: Standard AND LP Schottky

Part No.	Price	Part No.	Price	Part No.	Price	Part No.	Price
7400	13	7455	35	74126	57	74185	134
7401	13	7460	17	74128	74	74188	275
7402	14	7463		74132	73	74190	115
7403	14	7470	28	74133	29	74191	92
7404	14	7472	28	74136	40	74192	105
7405	18	7473	32	74138	60	74193	105
7406	38	7474	27	74139	64	74194	105
7407	38	7475	38	74141	56	74195	95
7408	17	7476	37	74142	265	74196	99
7409	17	7478		74143	312	74197	85
7410	15	7480	48	74144	312	74198	150
7411	20	7481	86	74145	85	74199	160
7412	17	7482	69	74147	175		
7413	30	7483A		74148	109		
7414	51	7484	97	74150	99		
7415	24	7485	104	74151	64		
7416	30	7486	40	74153	64		
7417	30	7489	205	74154	96		
7420	16	7490	33	74155	54		
7421	29	7491	76	74156	80		
7422	24	7492	38	74157	67		
7423	27	7493	32	74158	55		
7425	27	7494	78	74159	210		
7426	36	7495A	65	74160	82		
7427	27	7496	58	74161	92		
7428	35	7497	195	74162	92		
7430	17	74100	119	74163	92		
7432	25	74104	63	74164	104		
7433	40	74105	62	74165	105		
7434	40	74107	32	74166			
7435	33	74109	63	74167	20		
7440	17	74110	54	74168			
7441	74	74111	68	74169			
7442	70	74112	88	74170	230		
7443	115	74113		74172	625		
7444	112	74114		74173	170		
7445	94	74116	198	74174	87		
7446	94	74118	83	74175	87		
7447	82	74119	119	74176	75		
7448	56	74120	115	74177	78		
7449	65	74121	25	74180	85		
7450	17	74122	46	74181	165		
7451	17	74123	46	74182	160		
7452	17	74124	38	74183			
7454	17	74125	38	74184	135		

From the World's leading radio innovation source:

Apart from the MC3357, mentioned alongside, Ambit has the first easy-to-use low noise, low cost UHF dual gate MOSFET - the BF960 from Siemens. With a gain of 18dB, and a noise figure of only 2.8dB at 800MHz, you will see what we mean. At 200 MHz, the gain is 23dB, and NF only 1.6dB. Combine these figures with the famous ease of use of a dual gate MOSFET, and you have the easiest and most effective front end device yet. £1.60 each

Moving Coil Meters

Ambit offers a very wide range of low cost meters, together with the unique 'Meter Made' scale system for professional grade scale customizing:

Series	Scale Area	illumination	cost*
900	14x31mm	internal 12v	250p
920	30x50mm	from behind	275p
930	36x63mm	internal 12v	375p
940	twin 35x45mm	from behind	350p
950	55x45mm	from behind	300p

Stock movement 200uA/750Ω. The 930 series is 5% linear, others are 77uA at 50% FSD. These and many others available in quantity for OEM's. SAE for full scale details please. (Not in cat.)

Coils & Filters by TOKO

After a period of relative price stability, please note that some prices are increased as a direct result of the failure of £ versus stronger trading currencies. (Mainly Yen)

7 & 10mm IFTs for AM/FM - 1000s as 455/470kHz most types of approx 30p
 10.7MHz 33p

Short Wave Coils sets
 Now two ranges of impedance/coupling as 33p

TV audio and sound IFs/detectors
 Another new range in 10mm 33p
 6MHz ceramic IF sound filter 80p

Mixed VHF coils full catalogue 15p
 Ultra stable coils for 30 - 200MHz from 20p

Chokes - biggest range/biggest stocks
 Most E12 values ex stock, any to order
 78A series 1uH to 1mH 16p
 BRB series 100uH to 33mH 19p
 100R series 33mH to 120mH 33p

Radio, Audio, Comms ICs:

Only the very best quality - and only types we have used in our own laboratory tests

Radio frequency x mixers + oscillator

TD1082	DC to VHF front end system	1.95
TD1083/UNL2204	am/fm/aud in one IC	1.95
TD1090/UNL2242	am/fm hifi tuner system	3.35
HA1197	LF/30MHz am receiver system	1.40
CA3123E/uA720	LF/30MHz linear system	1.40
TBA651	LF/30MHz linear system	1.81
SD6000	DMOS RF/Mixer pair	3.75

IF amplifiers

CA3088E/KB4402	famous FM IF system	1.94
RA1137W/K 4420	as 3088 + deviation mute	2.20
CA3189E	update with deviation mute	2.75
TBA120a/SN7660N	FM if and detector	0.75
TBA120S	hi gain version TBA120	1.00
MC1350P	age IF amp/demodulator	1.35
MC1300P	synch AM demodulator	1.35
MC1495L	precision 4 quad multiplier	6.86
MC1496P	popular double balanced mixer	1.25

Communications circuits

KB4406	differential amplifier	0.50
KB4412	2 bal mixers/agg/gain/doub conv	2.55
KB4413	am/fm/ssb det. AGC, ANL, mute	2.75
KB4417	3mV mic preprocessor preamp	2.55
KB4423	FM noise blanker system	2.55

Audio preamps

LM1303	stereo high gain/low THD	1.81
LM1303	stereo audio optimized OA	0.99
TDA1054	high quality with alt option	1.95

Audio Power Amps

TBA1008	7W RMS overload protected	1.99
TDA2002	8W/251 in pentawatt package	1.95
TDA2020	15W RMS hifi power dc coupled	2.99
TC940	10W higher voltage B10	1.80
ULN293	1W 2.5 to 12v supply capability	1.00
LM3808N	1W power	1.00
LM380N14	2.5W power	1.00
HA1370	HIFI 15w in easy heatsink pack	2.99

Stereo Decoder Devices

MC1310/KB4400	original pll decoder	2.20
CA3090AQ	RCA's pll decoder	3.25
uA758	Buffered version of 1310	2.20
LM1307/uA707	non pll type	1.55
HA1196	advanced adj sep pll low thd	1.95
BF902	80* 40873 85* 40822 43p*	4.35

All ambit decoders are supplied with the LED beacon of your choice. Please state colour.

Discrete Semiconductors

Some of the biggest stocks of specialist MOS and FET transistors for radio in the UK

BF902 80* 40873 85* 40822 43p*
 40823 51p* MEM60 75p* BF256S 34p*

Most types for MF circuitry, inc new UHF T package types etc. See price list.

Hitachi VMOS 100W power devices:

Hitachi 2SK134 /2SJ48 100W comp. VMOS. Data and circuit info £1, and the devices themselves for £14.00 a pair *

DISCRETE LEDs from Telford, square and round, AMBIT has the best value.....

LED size (mm)	2.5x5	5 dia	2.5dia
RED	17p	14p	14p
Yellow	20p	15p	15p
Green	20p	16p	16p
Orange	24p/heL	29p/heL	17p

he = high efficiency L = lens and

Switch Systems: Check our combinations!

A very wide selection of BOTH Alps SUB series units, (Schadow/AB/Oron compatible) and the miniature DIALSTAT units. Available in DIY systems for maximum flexibility and low cost.

And Finally

Further details of these, and many more of the wonders of the world of wireless in the new Ambit catalogue - with magazine supplement 45p inc pp etc.
 Phone (0277) 216029/227050 9am-7pm, callers welcome anytime

AM/FM FILTERS ceramic and linear phase

CFSE/SFE107 stereo ceramic IF 10.7MHz filters in 5 groups 50p
 CFSE107 mono/roofing IF filter 50p
 BBR3125N 4pole linear phase 10.7MHz 150p
 BBR3132A 6pole linear phase 10.7MHz 250p

MPX pilot tone filters for 19 & 38kHz

BLR3107N	Stereo 4k7 impedance	215c
BLR2007	Stereo 3k3 impedance	220c
BLR3152	Mono 4k7 impedance	100p
BLR3157	Mono 4k7/3k0 imp	100p

AM/FM/SSB IF FILTERS

MFL series	2.4kHz ssb /455kHz carrier	1195p
MFH series	4.5/7kHz BW on 455kHz	195p
MFK series	7.9kHz BW on 455kHz	165p
LFY455D	12kHz 4 ele ladder on 455kHz	125p

7400 TTL	7400	7401	7402	7403	7404	7405	7406	7407	7408	7409	7410	7411	7412	7413	7414	7415	7416	7417	7418	7419	7420	7421	7422	7423	7424	7425	7426	7427	7428	7429	7430	7431	7432	7433	7434	7435	7436	7437	7438	7439	7440	7441	7442	7443	7444	7445	7446	7447	7448	7449	7450	7451	7452	7453	7454	7455	7456	7457	7458	7459	7460	7461	7462	7463	7464	7465	7466	7467	7468	7469	7470	7471	7472	7473	7474	7475	7476	7477	7478	7479	7480	7481	7482	7483	7484	7485	7486	7487	7488	7489	7490	7491	7492	7493	7494	7495	7496																																																																																																																																																																																																																																																																																																																																																																																											
-12	74100	94	74107	28	74221	45	74279	70	74284	6.65	74293	1.35	74298	1.92	74300	1.95	74303	2.12	74310	1.78	74317	1.06	74320	1.00	74323	1.00	74327	1.00	74330	1.00	74333	1.00	74336	1.00	74339	1.00	74342	1.00	74345	1.00	74348	1.00	74351	1.00	74354	1.00	74357	1.00	74360	1.00	74363	1.00	74366	1.00	74369	1.00	74372	1.00	74375	1.00	74378	1.00	74381	1.00	74384	1.00	74387	1.00	74390	1.00	74393	1.00	74396	1.00	74399	1.00	74402	1.00	74405	1.00	74408	1.00	74411	1.00	74414	1.00	74417	1.00	74420	1.00	74423	1.00	74426	1.00	74429	1.00	74432	1.00	74435	1.00	74438	1.00	74441	1.00	74444	1.00	74447	1.00	74450	1.00	74453	1.00	74456	1.00	74459	1.00	74462	1.00	74465	1.00	74468	1.00	74471	1.00	74474	1.00	74477	1.00	74480	1.00	74483	1.00	74486	1.00	74489	1.00	74492	1.00	74495	1.00	74498	1.00	74501	1.00	74504	1.00	74507	1.00	74510	1.00	74513	1.00	74516	1.00	74519	1.00	74522	1.00	74525	1.00	74528	1.00	74531	1.00	74534	1.00	74537	1.00	74540	1.00	74543	1.00	74546	1.00	74549	1.00	74552	1.00	74555	1.00	74558	1.00	74561	1.00	74564	1.00	74567	1.00	74570	1.00	74573	1.00	74576	1.00	74579	1.00	74582	1.00	74585	1.00	74588	1.00	74591	1.00	74594	1.00	74597	1.00	74600	1.00	74603	1.00	74606	1.00	74609	1.00	74612	1.00	74615	1.00	74618	1.00	74621	1.00	74624	1.00	74627	1.00	74630	1.00	74633	1.00	74636	1.00	74639	1.00	74642	1.00	74645	1.00	74648	1.00	74651	1.00	74654	1.00	74657	1.00	74660	1.00	74663	1.00	74666	1.00	74669	1.00	74672	1.00	74675	1.00	74678	1.00	74681	1.00	74684	1.00	74687	1.00	74690	1.00	74693	1.00	74696	1.00	74699	1.00	74702	1.00	74705	1.00	74708	1.00	74711	1.00	74714	1.00	74717	1.00	74720	1.00	74723	1.00	74726	1.00	74729	1.00	74732	1.00	74735	1.00	74738	1.00	74741	1.00	74744	1.00	74747	1.00	74750	1.00	74753	1.00	74756	1.00	74759	1.00	74762	1.00	74765	1.00	74768	1.00	74771	1.00	74774	1.00	74777	1.00	74780	1.00	74783	1.00	74786	1.00	74789	1.00	74792	1.00	74795	1.00	74798	1.00	74801	1.00	74804	1.00	74807	1.00	74810	1.00	74813	1.00	74816	1.00	74819	1.00	74822	1.00	74825	1.00	74828	1.00	74831	1.00	74834	1.00	74837	1.00	74840	1.00	74843	1.00	74846	1.00	74849	1.00	74852	1.00	74855	1.00	74858	1.00	74861	1.00	74864	1.00	74867	1.00	74870	1.00	74873	1.00	74876	1.00	74879	1.00	74882	1.00	74885	1.00	74888	1.00	74891	1.00	74894	1.00	74897	1.00	74900	1.00	74903	1.00	74906	1.00	74909	1.00	74912	1.00	74915	1.00	74918	1.00	74921	1.00	74924	1.00	74927	1.00	74930	1.00	74933	1.00	74936	1.00	74939	1.00	74942	1.00	74945	1.00	74948	1.00	74951	1.00	74954	1.00	74957	1.00	74960	1.00	74963	1.00	74966	1.00	74969	1.00	74972	1.00	74975	1.00	74978	1.00	74981	1.00	74984	1.00	74987	1.00	74990	1.00	74993	1.00	74996	1.00	74999	1.00

TOTAL AMPLIFICATION FROM CRIMSON ELEKTRIK

WE NOW OFFER THE WIDEST RANGE OF SOUND PRODUCTS

STEREO PRE-AMPLIFIERS



MC 1

POWER SUPPLIES



REG 1

POWER AMPLIFIERS



CPR 1

POWER SUPPLIES



TOROIDAL

CPR 1 — THE ADVANCED PRE-AMPLIFIER

The best pre-amplifier in the U.K. The superiority of the CPR 1 is probably in the disc stages. The overload margin is a superb 40dB. This together with the high slew rate ensures clean top end with high output cartridges tracking heavily modulated records. Common mode distortion is eliminated by an unusual design. R.I.A.A. is accurate to 1dB. Signal to noise ratio is 70dB relative to 3.5mV. Distortion < 0.05% at 20dB overload 20kHz. Following this stage is the flat gain/balance stage to bring tape, tuner etc., up to power amp signal levels. Signal to noise ratio 66dB, slew rate 3V/µs, T.H.D. 20Hz - 20kHz < 0.05% at any level. F.E.T. muting. No controls are fitted. There is no provision for tone controls. CPR 1 size is 135x80x20mm. Supply to be ±15 volts.

POWER AMPLIFIER MODULES

CE 608 60W/8 ohms 35-0-35V
 CE 1004 100W/4 ohms 35-0-35V
 CE 1008 100W/8 ohms 45-0-45V
 CE 1704 170W/4 ohms 65-0-65V
 CE 1708 170W/8 ohms 65-0-65V

MC 1 PRE-AMPLIFIER

Suitable for nearly all moving-coil cartridges. Sensitivity 70/170µV switchable on the p.c.b. This module brings signals from the now popular low output moving-coil cartridges up to 3.5mV (typical signal required by most pre-amp disc inputs). Can be powered from a 9V battery or from our REG 1 regulator board.

TOROIDAL POWER SUPPLIES

CP51 for 2 x CE 608 or 1 x CE 1004
 CP52 for 2 x CE 1004 or 2 x CE 608
 CP53 for 1 x CE 1008 or 1 x CE 1704
 CP54 for 1 x CE 1008
 CP55 for 1 x CE 1708
 CP56 for 2 x CE 1704 or 2 x CE 1708

REG 1 — POWER SUPPLY

The regulator module, REG 1 provides 15-0-15v to power the CPR 1 and MC 1. It can be used with any of our power amp supplies or our small transformer TR 6. The power amp kit will accommodate it.

POWER AMP KIT

These are available in two versions — one uses standard components, and the other (the S) uses MO resistors where necessary and tantalum capacitors.

CPR1 £29.49 CPRI5 £39.99
 MC1 £18.50 MC15 £29.49

POWER AMPLIFIERS

It would be pointless to list in so small a space the number of recording studios, educational and government establishments, etc. who have been using CRIMSON amps satisfactorily for quite some time. We have a reputation for the highest quality at the lowest prices. The power amp is available in five types, they all have the same specification: T.H.D. typically 0.1% any power 1kHz 8 ohms, T.I.D. insignificant, slew rate limit 2.5V/µs, signal to noise ratio 110dB, frequency response 10Hz-35kHz - 3dB, stability unconditional, protection drives any load safely, sensitivity 775mV (250mV @ 100mV on frequency), size 120 x 80 x 25mm.

POWER SUPPLY

REGI £6.75 TR6 £7.75

HEATSINKS

Light duty 50mm 2 C/W
 Medium power, 100mm, 1 1/2 C/W
 Disco group, 150mm, 1 1/2 C/W
 Fan 80mm state 120 or 240v
 Fan mounted on two drilled 100mm heatsinks
 2 x 4 C/W 65 C max. with two 170W modules.

BRIDGE DRIVER, BDI

Obtain up to 340W using 2 x 170W amps and this module. BDI £5.40

CRIMSON ELEKTRIK

1A STAMFORD STREET, LEICESTER LE1 6NL, TEL. (0533) 537722

All prices shown are UK only and include VAT and post. COD 90p extra. £100 limit. Export is no problem. Please write for specific quote. Send large SAE or 3 International Reply Coupons for detailed information.

Understanding Digital Electronics

New teach-yourself courses

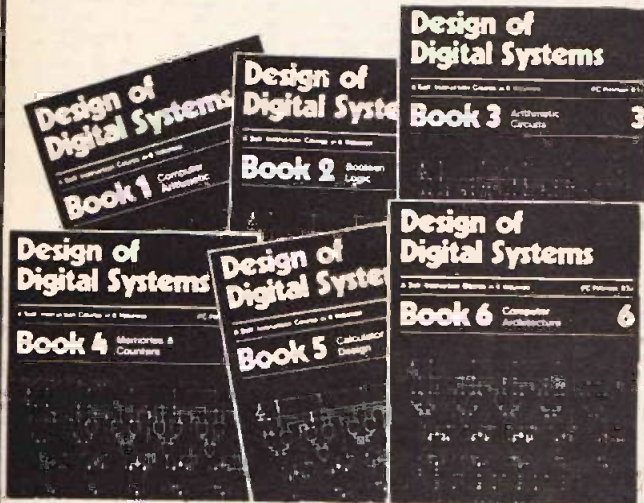

Design of digital Systems is written for the engineer seeking to learn more about digital electronics. Its six volumes — each A4 size — are packed with information, diagrams and questions designed to lead you step-by-step through number systems and Boolean algebra to memories, counters and simple arithmetic circuits, and finally to a complete understanding of the design and operation of calculators and computers.

The contents of Design of Digital Systems include:

- Book 1** Octal, hexadecimal and binary number systems; conversion between number systems; representation of negative numbers; complementary systems; binary multiplication and division.
- Book 2** OR and AND functions; logic gates: NOT, exclusive OR, NAND, NOR and exclusive-NOR functions; multiple input gates; truth tables; De Morgans Laws; canonical forms; logic conventions; Karnaugh mapping; three-state and wired logic.
- Book 3** Half adders and full adders; subtractors; serial and parallel adders; processors and arithmetic logic units (ALUs); multiplication and division systems.
- Book 4** Flip flops; shift registers; asynchronous and synchronous counters; ring, Johnson and exclusive-OR feedback counters; random access memories (RAMs) and read only memories (ROMs).
- Book 5** Structure of calculators; keyboard encoding; decoding display data; register systems; control unit; program ROM; address decoding; instruction sets; instruction decoding; control program structure.
- Book 6** Central processing unit (CPU); memory organisation; character representation; program storage; address modes; input/output systems; program interrupts; interrupt priorities; programming; assemblers; computers; executive programs; operating systems and time sharing.



Digital Computer Logic and Electronics is designed for the beginner. No mathematical knowledge other than simple arithmetic is assumed, though the student should have an aptitude for logical thought. It consists of four volumes — each A4 size — and serves as an introduction to the subject of digital electronics. Everyone can learn from it — designer, executive, scientist, student, engineer.

Contents include: Binary, octal and decimal number systems; conversion between number systems; AND, OR, NOR and NAND gates and inverters; Boolean algebra and truth tables; De Morgans Laws; design of logic circuits using NOR gates; R-S and J-K flip flops; binary counters, shift registers and half adders.

CAMBRIDGE LEARNING ENTERPRISES, UNIT 12, RIVERMILL SITE, FREEPOST, ST. IVES, HUNTINGDON, CAMBS, PE17 4BR, ENGLAND
TELEPHONE: ST. IVES (0480) 67446
 PROPRIETORS: DRAYRIDGE LTD. REG. OFFICE: RIVERMILL LODGE, ST. IVES
 REGD. IN ENGLAND No. 1328762

In the years ahead the products of digital electronics technology will play an important part in your life. Calculators and digital watches are already commonplace. Tomorrow a digital display could show your vehicle speed and petrol consumption; you could be calling people by entering their name into a telephone which would automatically look up their number and dial it for you.

These courses were written by experts in electronics and learning systems so that you could teach yourself the theory and application of digital logic. Learning by self-instruction has the advantages of being faster and more thorough than classroom learning. You work at your own pace and must respond by answering questions on each new piece of information before proceeding.

After completing these courses you will have broadened your career prospects and increased your fundamental understanding of the rapidly changing technological world around you.

The six volumes of Design of Digital Systems cost only: £8.10
And the four volumes of Digital Computer Logic and Electronics cost only: £4.60
But if you buy both courses, the total cost is only: £12.00

+ 90p. post & packing
 + £1 post & packing

Price includes surface mail anywhere in the world — Airmail extra.

Flow Charts & Algorithms

HELP YOU PRESENT:

safety procedures, government legislation, office procedures, teaching materials and computer programs by means of YES and NO answers to questions.

THE ALGORITHM WRITER'S GUIDE explains how to define the questions, put them in the best order and draw the flow chart, with numerous examples shown. All that students require is an aptitude for logical thought. Size: A5, 130 pages. This book is a MUST for those with things to say.

£2.95 + 45p post & packing by surface mail anywhere in the world. Airmail extra.

GUARANTEE

If you are not entirely satisfied your money will be refunded.

Cambridge Learning Enterprises, Unit 12, Rivermill Site, Freepost, St. Ives, Huntingdon, Cambs. PE17 4BR England.

Please send me the following books:

- sets Digital Computer Logic & Electronics @ £5.50, p & p included
- sets Design of Digital Systems @ £9.00, p. & p. included
- Combined sets @ £13.00, p & p included
- The Algorithm Writer's guide @ £3.40, p & p included

Name

Address

I enclose a cheque/PO payable to Cambridge Learning Enterprises for £

Please charge my Access/Barclaycard/Visa/Eurocard/Mastercharge/Interbank account number

Signature

Telephone orders from credit card holders accepted on 0480-67446 (ansafone). Overseas customers should send a bank draft in sterling drawn on a London Bank.

The latest kit innovation!

from **Sparkrite**

Sparkrite was featured by Shaw Taylor in "DRIVE IN"

the quickest fitting
CLIP ON
capacitive discharge
electronic ignition
in KIT FORM

- Smoother running
- Instant all-weather starting
- Continual peak performance
- Longer coil/battery/plug life
- Improved acceleration/top speeds
- Optimum fuel consumption

Sparkrite X4 is a high performance, high quality capacitive discharge, electronic ignition system in kit form. Tried, tested, proven, reliable and complete. It can be assembled in two or three hours and fitted in 1/3 mins.

Because of the superb design of the Sparkrite circuit it completely eliminates problems of the contact breaker. There is no misfire due to contact breaker bounce which is eliminated electronically by a pulse suppression circuit which prevents the unit firing if the points bounce open at high R.P.M. Contact breaker burn is eliminated by reducing the current to about 1/50th of the norm. It will perform equally well with new, old, or even badly pitted points and is not dependent upon the dwell time of the contact breakers for recharging the system. Sparkrite incorporates a short circuit protected inverter which eliminates the problems of SCR lock on and, therefore, eliminates the possibility of blowing the transistors of the SCR. (Most capacitive discharge ignitions are not completely foolproof in this respect). The circuit incorporates a voltage regulated output for greatly improved cold starting. The circuit includes built in static timing light, systems function light, and security changeover switch. All fits fit vehicles with coil/distributor ignition up to 8 cylinders.

THE KIT COMPRISES EVERYTHING NEEDED

Die pressed epoxy coated case. Ready drilled, aluminium extruded base and heat sink, coil mounting clips, and accessories. Top quality 5 year guaranteed transformer and components, cables, connectors, P.C.B., nuts, bolts and silicon grease. Full instructions to assemble kit neg. or pos. earth and fully illustrated installation instructions.

NOTE - Vehicles with current impulse tachometers (Smiths code on dial RV1) will require a tachometer pulse slave unit. Price £3.35 inc. VAT post & packing

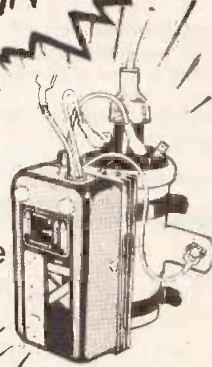

Electronics Design Associates, Dept. ET 10
82 Bath Street, Walsall, WS1 3DE. Phone: (9) 614791

Name _____
Address _____

Phone your order with Access or Barclaycard

Inc. VAT and P.P.

QUANTITY REQ'D

Send SAE if brochure only required.

I enclose cheque/PO's for

X4 KIT £14.95

TACHS PULSE SLAVE UNIT £3.35

£

Cheque No. _____

Access or Barclaycard No. _____

GREENWELD

443 Millbrook Road Southampton
SO1 0HX Tel: (0703) 772501

All prices quoted include VAT. Add 25p UK/BFPO Postage. Most orders despatched on day of receipt. SAE with enquiries please. MINIMUM ORDER VALUE £1. Official orders accepted from schools, etc. (Minimum invoice charge £5). Export/Wholesale enquiries welcome. Wholesale list now available for bona-fide traders. Surplus components always wanted.

BUY A COMPLETE RANGE OF COMPONENTS AND THESE PACKS WILL HELP YOU

- * **SAVE ON TIME**—No delays in waiting for parts to come or shops to open!
- * **SAVE ON MONEY**—Bulk buying means lowest prices—just compare with others!
- * **HAVE THE RIGHT PART**—No guesswork or substitution necessary!

ALL PACKS CONTAIN FULL SPEC BRAND NEW, MARKED DEVICES—SENT BY RETURN OF POST, VAT INCLUSIVE PRICES.

K001 50V ceramic plate capacitors, 5% 10 of each value 22pF to 1000pF. Total 210. **£3.35**

K002 Extended range, 22pF to 0.1µF 330 values **£4.90**

K003 Polyester capacitors, 10 each of these values 0.01, 0.015, 0.022, 0.033, 0.047, 0.068, 0.1, 0.15, 0.22, 0.33, 0.47µF 110 altogether for **£4.75**

K004 Mylar capacitors, min 100V type 10 each all values from 1000pF to 10,000pF Total 130 for **£3.75**

K009 Extended mylar pack. Contains all values from 1000pF to 0.47µF. Total 290 capacitors to **£11.25**

K005 Polystyrene capacitors, 10 each value from 10pF to 10,000pF, E12 Series 5% 160V Total 370 for **£12.30**

K006 Tantalum bead capacitors, 10 each of the following 0.1, 0.15, 0.22, 0.33, 0.47, 0.68, 1, 2.2, 3.3, 4.7, 6.8, all 35V: 10/25, 15/16, 22/16, 33/10, 47/6, 100/3. Total 170 tants for **£14.20**

K007 Electrolytic capacitors 25V working, small physical size, 10 each of these popular values 1, 2.2, 4.7, 10, 22, 47, 100µF. Total 70 for **£3.50**

K008 Extended range, as above, also including 220, 470 and 1000µF. Total 100 for **£5.90**

K021 Miniature carbon film 5% resistors, CR25 or similar, 10 of each value from 10R to 1M, E12 series. Total 610 resistors **£6.00**

K022 Extended range, total 850 resistors from 1R to 10M **£8.30**

K041 Zener diodes, 400mW 5% 82Y88 etc. 10 of each value from 27V to 36V, E24 series. Total 280 for **£15.30**

K042 As above but 5 of each value **£8.70**

STEREO AMPLIFIER CHASSIS £5.50

Complete and ready built. Controls Bass, treble, volume/on-off, balance. B transistor circuit gives 2 watts per channel output. Just needs transformer and speakers for low cost stereo amp. Suitable metal cabinet (W374) **£2.00**—or buy the amp, case and transformer for **£10.00** and get DIN speaker sockets and knobs free!!

AMPLIFIER KIT £1.75

Mono gen. purpose amp with tone and vol/on-off controls. Utilizes sim. circuitry to above amp. Output 2W into 8 ohms. Input matched for crystal cartridge. 4 transistor circuit. Simple to build on PCB provided. Can be either battery or mains operated. (For mains powered version add **£2.20** for suitable transformer) Blue vinyl covered aluminium case to suit (W372) **£1.30**.

BC182B OFFER

Special Offer for quantity users. 1k 035 + VAT, 5k .032 + VAT. Price negotiable on 10k + approx. 80k available.

PC ETCHING KIT MK III

Now contains 200 sq ins copper clad board, 1lb Ferric Chloride, DALO etch-resist pen, abrasive cleaner, two miniature drill bits, etching dish and instructions. **£4.25**.

EDGE CONNECTORS

Special purchase of these 0.1 pitch double-sided gold-plated connectors enables us to offer them at less than one-third of their original list price! 18 way **41p**; 21 way **47p**; 32 way **72p**; 40 way **90p**.

THE NEW 1978-9 GREENWELD CATALOGUE

FEATURES INCLUDE:

- * 50p Discount Vouchers
 - * Quantity prices for bulk buyers
 - * Bargain List Supplement
 - * Reply Paid Envelope
 - * Priority Order Form
 - * VAT inclusive prices
- Price 30p + 15p Post

HEAT SINK OFFER

Copper T05 sink 17mm dia x 20mm. 10 for **40p**; 100 for **£3**; 1,000 for **£25**.

74 SERIES PACK

Selection of boards containing many different 74 series ICs. 20 for **£1**; 50 for **£2.20**; 100 for **£4**.

TMS4030 RAM

4096 bit dynamic RAM with 300ns access time; 470ns cycle time, single low capacitance high level clock input; Fully TTL compatible; Low power dissipation. Supplied with data **£2.75**.

MISCELLANEOUS ICs

Supplied with data if requested. MC3302 quad comp. **120p**; 710 diff comp (TO99) **40p**; ZN1034E precision timer **£2.25**; LM711 Dual diff comp **65p**; LM1303 dual stereo pre-amp **75p**; MC1469R voltage reg **£1.50**; UPC1025H audio **£3.50**; 575C2 audio **£2.88**; TDA2640 audio **£2.92**; TBA810S audio **70p**; SN75110 dual line driver **70p**; MC8500 CRCC gen POA.

EXPERIMENTERS CALCULATOR

Based on the C500 chip, this pack of parts enables the more experienced constructor to make an 8 digit 4 function calculator. The comprehensive data supplied includes full-size layout of PCB required, types of suitable display and keyboard that can be used etc. Components included in the pack are C500 calculator chip, driver IC, all components for inverter/clock circuits, Rs Cs etc. All for only **£3.50**.

RELAYS

WB47 Low profile PC mtng 10x33x20mm 6V coil, SPCO 3A contacts **93p**.
WB32 Sub. min type, 10x19x10mm 12V coil DPCO 2A contacts **£1.15**.
W701 6V SPCO 1A contacts 20x30x25mm. Only **56p**.
W817 11 pin plug in relay; rated 24V AC, but works well on 6V DC. Contacts 3 pole c/o rated 10A **95p**.
W819 12V 1250R DPCO 1A contacts. Size 29x22x18mm min. plug-in type **72p**.
W839 50V ac (24V DC) coil. 11 pin plug-in type. 3 pole c/o 10A contacts. Only **85p**.
WB46 Open construction mains relay. 3 sets 10A c/o contacts. **£1.20**.
Send SAE for our relay list—84 types listed and illustrated.

LOW COST PLASTIC BOXES

Made in high impact ABS. The lids are retained by 4 screws into brass inserts. Interior of box has PCB guide slots (except V219).

V210	80x62x40mm black	58p
V213	100x75x40mm black	72p
V216	120x100x45mm black	86p
V219	120x100x45mm white	86p

SPECIAL SUMMER OFFERS

Audio ICs			
76003N	£1.40	76013N	£1.00
76023N	£1.00	76033N	£1.40
LM380	80p	TBA810S	90p

Linear ICs etc.			
741(BDIL)	18p	8D131	24p
555	25p	8D132	28p
1N4148	2p	2N3819	18p

DIODE SCOOP!!

We have been fortunate to obtain a large quantity of untested, mostly unmarked glass silicon diodes. Testing a sample batch revealed about 70% useable devices—signal diodes, high voltage rets and zeners may all be included. These are being offered at the incredibly low price of **£1.25**/1,000—or a bag of 2,500 for **£2.25**. Bag of 10,000 **£8**. Box of 25,000 **£17.50**. Box of 100,000 **£60**.



WIRE WRAPPING CENTRE



HOBBY WRAP Model BW 630



Battery Wire-Wrapping Tool Complete with Bit and Sleeve

AC26.75 BC31.95 CC2.82 DC7.44

WIRE-WRAPPING TOOL

or .025" (0.63mm) sq post "MODIFIED" wrap, positive indexing, anti-overwrapping device

- A For AWG 30 BW 630
- B For AWG 26-28 BW 2628
- C Bit for AWG 30 BT 30
- D Bit for AWG 26-28 BT 2628

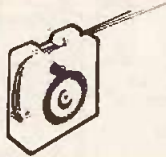

3 IN 1 WIRE DISPENSER
New wire dispenser cuts and strips three different colours of wire. Quick and easy to use pocket size. Wire Size: 30 AWG, 50 ft. Red, Blue, White Kynar insulated.

£4.07

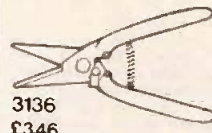

OK PLIERS AND CUTTERS UNIVERSAL CUTTER
Cuts everything. Leather, wire, plastic, tin-plate, cardboard. Stainless steel blades. Just one of the range of high quality pliers, cutters, tweezers and screwdrivers.

3136 £3.46

DIP/IC EXTRACTOR TOOL £1.19

The EX-1 Extractor is ideally suited for hobby enthusiast or lab engineer. Featuring one piece spring steel construction. It will extract all LSI, MSI and SSI devices of from 8 to 24 pins. Extractor Tool EX-1

DIP/IC INSERTION TOOL WITH PIN STRAIGHTENER £2.79

INS-1416



WIRE-WRAPPING KIT
Contains: Hobby Wrap Tool WSU-30, Wire Dispenser WD-30-B, (2) 14 DIP's, (2) 16 DIP's, Hobby Board H-PCB-1, DIP/IC Insertion Tool INS-1416 and DIP/IC Extractor Tool EX-1.

Wire-Wrapping Kit WK-4B (Blue) £19.22



IC TEST CLIPS £2.97 FOR DUAL-IN-LINE PACKAGES
• Provide full access to integrated circuit DIP leads.
• Remove DIP's damage free.
• Available in sizes to accommodate all DIP's: TC-14 fits 14-pin DIP's etc.

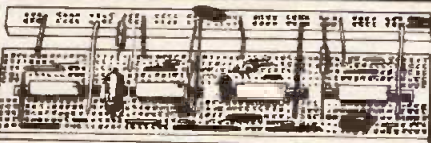

FROM 80p TERMINAL AND DISTRIBUTION STRIPS
Bread boarding building blocks with universal matrices of solderless plug-in tiepoints.
• Facilitate quick, solderless circuit build-up and check-out on universal .1" x .1" matrix.

- Are offered in ten configurations.
- Accept all components with leads up to .032" diameter.
- Require no special patch cords.
- Includes integral non-shortening instant mounting backing.



HOBBY WRAP TOOL
Wire-wrapping, stripping, unwrapping tool for AWG 30 or .025 (0.63mm) Square Post.

A £4.74 B £5.07

Regular Wrap A WSU-30 Modified Wrap B WSU-30M

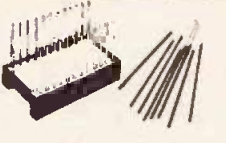

DIP SOCKET
Dual-in-line package, 3-level wire-wrapping, phosphor bronze contact, tin-inlay finish pins .025 (0.63mm) sq., .100 (2.54mm) centre spacing.

14 Pin Dip Socket	14 Dip
16 Pin Dip Socket	16 Dip

FROM 29p

RIBBON CABLE ASSEMBLY £2.92
With 14 Pin Dip Plug 2 Long DE 14.2
With 14 Pin Dip Plug 4 Long DE 14.4
With 14 Pin Dip Plug 8 Long DE 14.6
With 16 Pin Dip Plug 2 Long DE 16.2
With 16 Pin Dip Plug 4 Long DE 16.4
With 16 Pin Dip Plug 8 Long DE 16.8



See us at **BREAD BOARD '78** 21st-25th November. Seymour Hall, London Stand Nos. A5-A6

OK Machine & Tool U.K. Limited

48a The Avenue, Southampton SO12SY

Telephone Southampton (0703) 38966 7 Telex 477222 Cablegram OKMAC

DISTRIBUTORS WANTED***

TAMTRONIK LTD. (DEPT. ETI)

217 Toll End Road, Tipton West Midlands DY4 0HW. Tel. 021-557 9143

Mo. Issue	PROJECT	Ref.	PCB	Component Pack	Hardware Pack	Case (Screened)	Total
TOP	Graphic Equaliser	601	1.60	14.23	4.30	—	20.13
	Graphic Equaliser PSU	602	.55	1.29	—	1.84	3.68
	R F Attenuator	603	—	.26	1.54	1.35	3.15
	Watchdog	604	.85	4.09	3.95	5.53	18.75
	Watchdog PSU	605	.65	1.49	3.95	—	6.09
PROJECTS	Sweep Oscillator	606	2.60	21.07	8.16	4.28	36.11
	Stereo Simulator	607	.60	2.30	5.3	2.24	5.67
	Freezer Alarm	608	.55	.92	3.85	1.65	6.97
	General Purpose Pre-Amp	609	65	3.13	7.10	—	3.78
	G S R Monitor	610	.70	4.70	6.15	3.95	16.45
	Burglar Alarm	611	.60	2.15	1.65	—	8.90
	Headlight Reminder	612	.70	3.40	2.95	3.95	10.00
	Bench Amplifier	615	.70	1.31	1.62	—	2.93
	Audio Visual Metronome	616	—	10.10	8.30	3.15	23.15
	Comander	617	1.60	6.46	—	—	7.76
	50 watt High Power Amp	618	1.30	9.16	—	—	10.46
	100 watt High Power Amp	619	1.30	—	—	—	14.65
	High Power Amp PSU	620	1.10	5.66	7.89	—	5.73
	LED Dice	624	.50	2.92	.66	1.65	5.73
	Marker Generator	626	.80	3.68	1.49	.90	6.87
	Skeet	627	1.60	11.12	.97	4.53	18.22
	Flash Trigger	628	.65	3.48	.84	1.65	6.62
	Disco Lightshow	629	3.05	12.79	5.85	—	21.69
	Pink Noise Generator	630	.60	1.00	—	1.65	3.25
Nov 76	541 Train Controller	T001	.75	5.27	5.84	3.95	15.81
Jan 77	444 5-watt Stereo	T002	2.00	14.03	6.84	3.45	26.32
Feb 77	448 Stereo Disco Mixer	T003	1.60	13.74	.87	—	16.21
Dec 77	Clock B	T004	2.10	11.31	—	—	13.41
Jan 78	House Alarm A	T005	2.00	10.93	3.05	9.50	29.37
	House Alarm B	T006	.85	3.04	—	—	18.97
Feb 78	Metal Locator Mk. II	T007	.92	5.91	8.76	3.38	4.79
Mar 78	Frequency Shifter PSU	T008	.65	4.14	—	—	20.89
Mar 78	Frequency Shifter	T009	1.50	16.99	—	2.40	25.62
Mar 78	LCD Meter	T010	1.00	24.62	—	—	7.07
Mar 78	Light Dimmer	T011	.55	3.40	3.12	—	13.36
Apr 78	Gas Monitor	T012	.80	10.11	1.10	1.35	7.86
May 78	Star Trek Radio	T013	.84	6.19	.83	3.46	22.11
Jun 78	Stars & Dots	T014	1.93	5.33	11.49	—	65.10
Jun 78	Spectrum Analyser	T015	8.32	35.76	16.02	5.00	14.45
June 78	Worm Oscillator	T016	.89	6.36	4.80	2.40	12.43
Jul 78	LFO Detector	T017	1.45	10.18	.80	—	1.72
Jul 78	Torch Finder	T018	.45	1.27	—	—	25.41
Jul 78	Temperature Meter	T019	1.00	24.41	—	—	4.93
Aug 78	Etiket	T020	.90	2.87	1.16	—	12.64
Sep 78	Cross Hatch Generator	T021	1.40	5.93	3.66	1.65	29.26
Sep 78	Slac Timer	T022	2.30	14.27	11.04	1.65	8.36
Sep 78	Wheel of Fortune	T023	1.35	4.34	.43	2.24	25.06
Oct 78	Complex Sound Generator	T024	2.95	10.15	11.96	—	12.84
Oct 78	R F Power Meter	T025	1.10	2.24	7.12	2.38	2.88
Oct 78	Power Bulge	T026	.60	.71	.76	.79	8.60
Oct 78	Telephone Bell Extension	T027	.95	3.48	3.02	2.15	13.11
Oct 78	Proximity Switch	T028	1.95	7.91	3.25	—	8.93
Feb 78	Ultra Sonic Receiver	T029	.60	3.38	4.95	—	4.47
Feb 78	Ultra Sonic Transmitter	T030	.45	.82	3.20	—	—

ONE STOP SHOPPING — P.C.B.s

Components, Hardware, Cases, Part Kits, Full Kits. A complete service to the ETI Constructor. All Prices incl. VAT P&P 30p per order.

Except where copyright restrictions exist PCBs are available for all projects from Sept 1976 and include

560 A, B, C (set 3)	4.60	Bongos	.65
710 2m Power Amp	.90	Loudhailer	.60
Double Dice	1.35	Continuity Tester	.50
152 A, B TV Patter Gen (set 2)	2.85	Spirit Level	.70
Hear. Rate Monitor	1.00	3-channel Tone Control	.85
Reaction Tester	1.45	Clock A	1.05
Metal Locator 549	.85	Experimenters Power Supply	.90
Door Bell	.65	555 Timer Board	.60
Drill Controller	.60	Hammer Throw (set 3)	4.80
630	.60	Porch Light	.95
Digital Frequency Meter (set 4)	2.90	RMS Meter	.70
Digital Thermometer	1.20	Rain Alarm	1.00

SYSTEM 68

M/F PSU	.90	VDU 'A'	2.70	VDU 'B'	2.65
CPU	2.35	631	2.50	TTY	2.00
Cuts & Ram	2.25	(PCBs are modified)	—	—	—

Discounts on any 3 PCBs 5%, any 4 PCBs 10%, any 5 PCBs 12.5%, any 6 PCBs 15% Full Set £12.00

"SON OF ETI"

HOBBY ELECTRONICS

THIS MONTH'S BARGAINS

100 x 1/4W 1K carbon resistors 30p

PCBs and Kits available from TAMTRONIK.

PCBs and Kits also available for everyday electronics, send SAE for details.

For a few kits it is not possible to supply ALL components. To avoid disappointment we recommend you send SAE requesting kit details. Please quote project and kit reference number when details of a specific kit is required. SAE automatically brings free catalogue.

OVER 100 KITS NOW AVAILABLE
TRADE AND EDUCATIONAL ENQUIRIES WELCOME

Visit our shop at:
32 MARKET PLACE, GREAT BRIDGE, TIPTON, WEST MIDLANDS

Mail Order or Telephone

Access

**SAME AS
ETI OFFER**

5 FUNCTION LCD

Hours, mins, secs,
month, date, auto calen-
dar, back-light, quality
metal bracelet.

£8.95



**SPECIAL
TO
ETI
READERS**

**Solar + alarm
LCD watch**

**SOLAR ALARM
WATCH**
* Hours, mins, secs
displayed.
* Day, date, day of
week.
* 24 hour penetrating
alarm.
* Quality metal bracelet.
* Powered from solar
panel.
* With battery back up,
* Back light + auto
calendar.
£29.95



*** QUARTZ LCD ALARM ***

Snooze + backlight Batteries last 1 year
approx. Includes batteries and travel pouch
Excellent value

£17.65



**THOUSANDS SOLD
11 FUNCTION
SLIM CHRONO**

6 digit 11 functions
* Hours, mins, secs.
* Day, date, day of week.
* 1/100, 1/10, secs, 10 x
secs, mins.
* Split and lap modes.
* Back light, auto calendar
* Only 8 mm thick.
This same watch is being
sold for £22.00 in newspaper
and magazine special offer
ads.

**Metac Price
£12.65**



SEIKO

The Seiko Quartz Collection encompasses a wide and exciting range of quartz watches for men and women. Day/Date quartz. Ultra-thin quartz. Digital quartz watches with liquid crystal display for continuous readout. Even a digital quartz alarm chronograph. It's what you'd expect of Seiko. The first quartz watch ever sold was a Seiko. And Seiko's expertise in every phase of the watchmaking process makes it possible for Seiko to make any part of any Seiko watch, and to exercise a unique quality control system through every step from design to completion. Whichever Seiko Quartz model you select, you get more than just a technologically advanced timepiece.



List Price £130
Metac Price £105



List Price £85
Metac Price £68



List Price £120
Metac Price £98



List Price £166
Metac Price £125

**HANIMEX
Electronic
LED Alarm Clock**

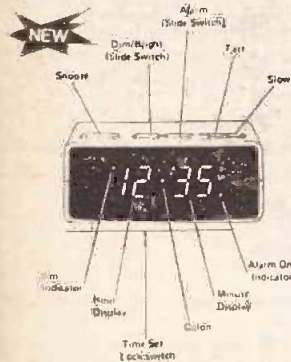

Features and Specification
* Hour, minute display
* Large LED display with p.m. and alarm on indicator
* 24 Hours alarm with on-off control
* Display flashing for power loss indication
* Repeatable 9 minute snooze
* Display bright/dim modes control
Size: 5 1/2 x 3 9/32 x 2 3/8 (131mm x 100mm x 60mm)
Weight: 1.43 lbs (0.65 kg)

£8.95 (Inclusive of VAT and Postage)

SOLAR

5 function LCD

* Solar panel with
battery back-up
* Back light + auto
calendar
* Hours, mins, secs,
day, date.
* Quality metal bracelet.

£12.95



**LADIES
LCD**

Only 25 x 20 mm and 6 mm
thick 5 function: hours,
mins, secs, day, date, +
back light and auto cal.
Elegant metal bracelet in
silver or gold. State pre-
ference.

£10.95

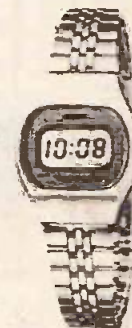

**ALARM
LCD**

6 digit 7 function hours,
mins, secs, day, date, day
of week, 24 hour penet-
rating alarm. Back light
+ auto calendar

Only £24.95



**THE METAC
DIGITAL CLOCKS
COMPLETE KIT**

★ Pleasant green display - 12/24 Hour readout
★ Silent Synchronous Accuracy - Fully electronic
★ Pulsating colon - Push-button setting
★ Building time 1 Hr - Attractive acrylic case
★ Easy-to-follow instructions - Size 10.5 x 5.7 x 8 cm
★ Ready drilled PCB to accept components
PRICE £6.65



**MICRO
CASSETTE
RECORDER**

Hand-held only 2 1/2 x 5 x
1 1/2 inch. Identical to well
known models being sold
at £35

**OUR PRICE
£24**

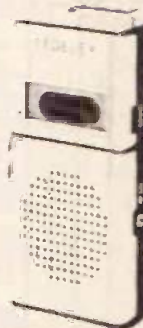

**SINCLAIR SCIENTIFIC
PROGRAMMABLE
+ free program library
worth £4.00**

ONLY £12.95 FROM METAC



All products carry full 12-
month guarantee. Please
add 30p P&P with all
orders. All prices include
VAT.

Shops open 9.30 to 6.00
daily.

Trade enquiries welcome.

COMPONENTS

2N3055 transistors 50p
2 inch LED's, red 12p
green 15p
yellow 15p
orange 15p
DL 704 displays 80p
DL 707 displays 80p
Watch batteries 70p
(state type)
Mercury tilt switches 50p
Crystal mic. inserts 50p

Also useful for sonic applications and
sound transmitters (buzzers etc)

**METAC
EXCLUSIVE
CALCULATOR
WATCH +
STOP-WATCH
SEIKO STYLE**

Calculator: X, +, x, -, /, K
Time: hours, mins, secs, day
date, day of week

PRICE £49



TV GAMES

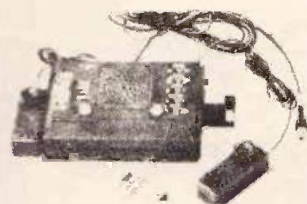

Black & white **£9.95** Colour **£12.95**
4 games, 2 ball speeds, 2 ball angles
2 bat sizes

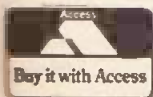

METAC Electronics & Time Centre

67 HIGH STREET
DAVENTRY, NORTHANTS
Tel. (032 72) 76545

327 EDGWARE ROAD
LONDON W2
Tel. (01) 723 4753

Barclay & Access welcome
Phone or Send Card Number
with order



MINI-ADS & CLASSIFIED

E.T.I. P.C.B.'s

Bus it with Arrows

Available for all ETI projects from day one of ETI, phone your order

SPECIAL OFFER—Single sided Pax PCB mat, four off 4 1/4" x 6 1/2", 99p all up



CROFTON ELECTRONICS LIMITED

35 GROSVENOR ROAD, TWICKENHAM MIDDLESEX TW1 4AD · Tel: 01-891 1923

HAPPY MEMORIES

21L02 RAM (450ns)
1-15 @ 95p, 16-63 @ 92p, 64 up @ 89p

2114EMM RAM (300ns)
1-3 @ £6 25, 4 up @ £6

2708 EPROM (450ns)
1-3 @ £7 25, 4 up @ £7

16 PIN DIL SOCKETS
Gold 22p, 100 up 21p
Tin 12p, 100 up 11p

RAMS LIKE A SPARE BIT — 1.2mm bits for Antex CX17 and CCN soldering irons 45p

Cheque or P.O. to
G. J. Greaves
5 Cranbury Terrace
Southampton
Hants. SO2 0LH
C.O.D. available at cost

All prices include V A T Add 20p postage

AT LOW COST

At last the complete single board

MICROCOMPUTER

The experimenter and hobbyist needs

VIM-1

Use the VIM by itself with its on board 28 double function keypad and 6 character LED display
Then expand to full mainframe via 3-44 way edge connectors
It comes to you assembled and tested
Just connect your +SV D1 5A power supply and

VIM-1 is operational in minutes
Three manuals provided enable you to MASTER MICROPROCESSOR TECHNOLOGY
Plus features include

- Hi speed cassette interface 185 bytes/sec
- 1K user RAM with sockets for additional 3K
- Sockets for 20K ROM expansion
- ASCII alpha/ numerics direct to an oscilloscope

- 4K SUPERMON MONITOR includes
- Single step with variable trace speed
- Register modify/inspect whilst in program
- Hex displacement calculator
- Black transfer plus much more

£199 plus 8% VAT = £15.92
TOTAL = £214.92

Plus full technical support and demonstrations from

ANDOR ELECTRONICS LTD.
11 The Precinct, Romiley, Stockport SK6 4AE
Tel: (061) 430-4770

DEAD or ALIVE OR JUST MIXED UP?

5-FUNCTION
13 AMP SOCKET TESTER



SAFELY SHOWS YOU!

Safety fast! Shows: **1**, If all wires correct, **2**, Live wire faulty, **3**, Live and Neutral wires reversed, **4**, Earth faulty, **5**, Neutral faulty. Shows exact fault instantly. British made.

£3.95 post free. Save time. Be sure. Be safe.

PERSONAL SAFETY CO.
Dept. ETI, P.O. Box 1
LLANRWST
Gwynedd, North Wales

1.2V NICADS

For UK orders add 60p for post and packing
All prices include V A T

BUTTON CELLS

	Dia.	Hgt.	Price/Cell
225mAh	25.0	7.5	0.65
600mAh	34.5	10.0	1.15

VENTED CELLS

(for fast charge)

			Price
0.45 Ah	17.5	28.0	0.95
0.5 Ah	HP7 or	Size "AA"	1.10
1.2 Ah	22.5	49.0	1.45
1.8 Ah	HP11 or	Size "C"	1.95
4.0 Ah	HP2 or	Size "D"	2.75
10.0 Ah	41.5	90.0	6.00
6.0V Pack	5x1.2 Ah nicads		7.50

Tags available at extra 10p per cell for 0.5Ah, 1.2 Ah and 1.8 Ah nicads only.

Charger — Suitable for any of the above vented nicads — charges up to twelve similar cells in a series at a 50mA or 200mA rate **£9.95**

Sizes approx. in mm
Mail order only

V & F SMALLCRAFT (POPLAR) LTD.
38 Stoneleigh Road, Clayhall, Ilford
Essex
01-550 6642

E.T.I. P.C.B.'s

Epoxy glass laminate — drilled and tinned

Complex Sound Gen	2.05
R.F. Power Meter	0.54
Power Bulge	0.30
Bell Extender	0.59
STAC Timer	1.99
Wheel of Fortune	0.98
Cross Hatch Gen	1.32
ETIWET	0.76
Metal Loc. II	0.88
Metronome	0.55
House Alarm A & B	2.47
Hammer Throw (3 of)	3.18
Clock A & B	2.85
3 ch. Tone Con	1.96
Dig Thermometer	1.08
Graphic Equal	1.38
TV Game	1.25

Many more available including this month's circuits

S.A.E. for full list. Prices include VAT. Please add 20p post and packing. Orders over £5 post free

P.C.B.s from your own artwork — write for quote

T.S.I. (St. Ives) Ltd.
37 Telegraph Street
Cottenham, Cambridge, CB4 4QU
Tel. (0954) 51177

TELERADIO for INSTRUMENTS AMPLIFIERS RADIO CONTROL COMPONENTS SEMI CONDUCTORS



Send S.A.E. for lists required.

Illustration shows low distortion Audio Oscillator type A0146
Distortion .0015% Range 100hz to 100Khz. Output 1v Sine & Square
Price **£35** (or in kit form **£30**) Tax extra 8% P.P. **£1 50**

TELERADIO ELECTRONICS
325 FORE STREET, EDMONTON, LONDON, N9 0PE
01-807 3719
Closed on Thursdays

A. Good quality ribbon microphones and amplifiers DCB includes 1 4 pole c/o level switch and 1 8 pole c/o lever switch and lamp, holder and reflector	75p
B. Microswitch 5A	8p
C. Smaller microswitch	8p
D. Two-channel unit will provide 2 independent channels for teleequipment servicescope	SAE for details
E. Receiver capsules	15p
F. Microphone capsules	10p
G. Black Bakelite telephones	£2.95
H. Handset only	50p
I. Modern phones	£6.95
J. Loudspeaking telephones	£39.50
K. Dials	£1.00
L. Coils	15p
M. 2 Microfarad condensers	10p
N. Ringers	40p
O. Cable, wire	per quote
P. Telephone Circuit boards	50p
Q. Solid metal work benches — wired — crated	£25.00
R. Radios, complete working without case	£1.50
S. Quantity Power Transistors V17X 94	Offers

Seven day delivery. Write to or telephone for further details

CONVERSATION PIECES (ETI) 55 Swindon Road
Cheltenham, Glos. 0242 35707

DIGITAC DIGITAL REV. COUNTER

The Digitac is a voltage impulse digital tachometer, which is suitable for all negative earth ignition systems. It has a 2 digit 7 segment display housed in a black case. Please specify no. of cylinders and if 6 or 12 volt system.

Ready built £19.78
Kit form £14.96
Prices are fully inclusive
(Quantity discounts)

ELECTRONEQUIP

36 Merton Avenue, Portchester
Hants PO16 9NE. 07018 73455

Linsley-Hood 75 watt Power Amp modules, built and tested, from £12.50. Complete module kit £10.50 inclusive. Linsley-Hood 75 watt amplifiers constructed and repaired, comprehensive range of spares in stock. Details and list free. I. G. Bowman Dept. ETI, 59 Fowey Avenue, Torquay, S. Devon

PRECISION POLYCARBONATE CAPACITORS

All high stability — extremely low leakage

40V AC RANGE (± 10%)		63V DC RANGE (E) each	
L (mm)	D	Each	µF (Tol ± 1% ± 2% ± 5%)
27	12.7	1.34	0.01-0.2 1.80 1.22 0.88
22	33	1.66	0.22-0.47 1.82 1.24 0.90
25	33	1.6	1.78 1.0 2.26 1.52 1.08
47	33	1.9	2.08 2.2 2.80 1.94 1.42
5	33	1.9	2.24 4.7 4.00 2.72 2.24
68	50.8	1.9	2.48 6.8 4.88 3.36 2.66
0	50.8	1.9	2.64 10.0 6.94 4.68 3.56
20	50.8	25.4	3.74 22.0 13.32 9.98 6.80

Additional values and closer tolerances avail upon request

TRANSISTORS, DIODES, I.C.s, Bridge Rectifiers, Capacitors, Plugs + Sockets, Vero, Fuses, etc. — a complete range is carried, please send for our free detailed price list which will be sent by return of mail.

RESISTORS High stability, low noise, carbon film ±5% tol 1/2W @ 40 C, 1/3W @ 70 C E12 series only — from 2.2 ohm to 4.7M. All 2p each; *5p/10 of any one value; 95p/100 of any one value; £4.35/500 (may be mixed in 100s); £8/1000 (may be mixed in 100s).

SPECIAL DEVELOPMENT PACK: 10 of each value 2.2 ohm to 2.2M (730 resistors) — £6.50 each. *W c/f 5% 2.2 ohm to 10M — 5p each; 2W c/f 5% 10 ohm to 10M — 8p each.

PRESETS: 01 W submin. skeleton presets — vertical or horizontal 100 ohm to 1M, 7p each, £3/50, £5/100, £22 50/500, £40/1,000. Values may be mixed.

DIODES: 1+ 10+ 50+ 100+ (Values 100V — 5% 3V-33V 10p 9 1/2p 9p 8p may be 2.3-200V 18p 17 1/2p 16 1/2 15p mixed)

TANTALUM BEAD CAPACITORS: µF/V, 100V @ 22 0.33 0.47 0.68 1µF all at 35V @ 10p; 5 35 2.2/25 + 11p 2.2/35 @ 12p 4.7/35 @ 12p 6.8/35 @ 17p 10/25 @ 17p 10/35 @ 21p; 75 200 22/15 33/10, 47/6.3 @ 21p 68/3 @ 21p 100/3 @ 21p (deduct 1p each for qty. of 10+ — values may be mixed).

UK/Export add cost air/sea mail. Add 8% except those marked * add 12 1/2%. Wholesale price available to bona fide companies. Shop open 9 00 am-5 00 pm, Mon-Fri.

MARCO TRADING (Dept. T10)

The Old School, Edstaston, WEM,
Shropshire
Tel. WHIXALL 464 (STD: 094872)
(Props.: Minicost Trading Ltd.)

BARGAINS FOR THE ELECTRONIC HANDYMAN BRANDED LED DIGITAL ALARM CLOCKS

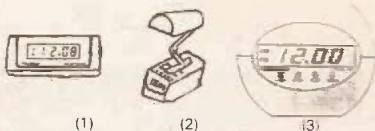

Returned to Service Department within guarantee period

- (1) With alarm repeat — S.R.S.P. of £17.00 offered at **£4.95** inc. VAT
- (2) With luxury lamp and repeat alarm as featured in most major U.K. Mail Order catalogues S.R.S.P. £31.00 — offered at **£8.95** inc. VAT
- (3) With integral luxury light and repeat alarm also as featured in most major U.K. Mail Order catalogues S.R.S.P. of £32.00 — offered at **£8.95** inc. VAT

These will be sold as received from our customers with the existing fault(s) and without guarantee

**PRESCOTT CLOCK AND
WATCH COMPANY LIMITED**
Prescott House, Humber Road, London NW2 6ER

Capacitors. Tantalum Bead (ITT Union Carbide, NCC). 50v .33uf, .68, 35v, 22 33 47 1-0 1-5 4.7, 6.8 16v 2.2 4.7 = 10p 10v 22uf 33 68 = 18p 63v 100uf = 20p 10v 100uf = 30p. Electrolytic 250v 10uf CE10 .08P. 1000 uf 63v erie 50p 50v, 4.7uf CEW 80 .06p, 10uf CRO4W .07p, 35v 33uf ITT .07 47 uf CEO&W .08 30v, 4700 uf Plessy 50, 25v 100uf Mullard 09, 470uf Mullard 17p 10v 1000uf CEO4W .15. Price breaks 50-199 less 10% 199-500 less 15%. 500 + less 20%. Same type components obtained to order. Min. order £2.00, .35p P&P all orders below £10.00. Larkswood Electronics, 25 Larkswood Road, Chingford London E4 9DS. 01-529 8255.

THE ROYAL FREE HOSPITAL HAMPSTEAD MEDICAL PHYSICS TECHNICIAN IV (ELECTRONICS)

An Electronics Technician is required for the Electronics Workshop of this major teaching hospital to assist with the development and maintenance of electronic circuits and equipment.

Applicants should hold the City and Guilds Final Certificate in appropriate subjects or an equivalent qualification. Some practical experience in the use of analogue and digital circuit techniques is desirable.

Salary on scale: £3,423-£4,488 per annum, including all allowances. The starting point depending on qualifications and experience and the successful candidate will be encouraged to study for a higher qualification, by means of Day Release.

Application Form (to be returned by 3rd November, 1978) and Job Description from the Personnel Department, The Royal Free Hospital, Pond Street, Hampstead, London NW3 2QC. Tel: 01-794 0500. Please quote ref: 0761.

Camden and Islington Area Health Authority (T)

L.C.D. CHRONOGRAPHS, 6 digit display stopwatch to 100th seconds. Lap timer, P.M. indicator, S.S. bracelet, display backlight. £16.95. L.C.D. Solar watch £16.95. Ladies L.C.D. watch S.S. or gilt bracelet £13.95. L.C.D. watch/stopwatch to seconds £13.95. Prices fully inclusive. Cheques, P.O.s to — RAM ELECTRONICS, 49 Avondale Road, Fleet Hampshire.

ETI ADVERTISEMENT INDEX

Ace	90
Ambit	97
Astra-Pak	98
Audio Electronics	13
Bamber	84
Baydis	53
Bi-Pak	4 & 5
Birkett	10
B.N.R.S.	78
Bull	53
Cambridge Learning	99
Catronics	90
Chittmead	34
Chromasonics	90
Crimson Elektrik	98
C.S.C.	42 & 43
Dalston Electronics	92
Delta Tech. & Co.	94
Discount Computing	82
Doram	49, 53
E.D.A.	100
Electrovalve	101
Fladar	92
Flairline	96
Gould Advance	14
Greenbank	88
Greenweld	100
H.B. Electronics	92
Henry's	78, 88, 92
Ibek Systems	42
I.L.P.	69
Integrated Circuits	95
Jeremy Lord	84
Kramer	42, 84, 96
L.B. Electronics	64
Lektrakit	36, 70
Maplin	108
Marshalls	77
Metac	103
Minikits	42
Mountiandene	64
Nicholls	64
Nic Models	92
O.K. Machine	102
P.B. Electronics	96
Powell	96
Powertran	2, 6
Progressive Radio	64
R.F. Equipment	10
Roger Squires	78
R.T.V.C.	83
Sentinel Supply	78
Sintel	89
Stevenson	12
Sinclair Radionics	61
Swanley	82
Tamtronik	102
Target	36
Technomatic	11
Teleplay	107
Tempus	62
Trampus	70
T.K.	94
Trident	52
Vero	94
Videotime	50
Watford	8, 9
Wilmslow Audio	36

PRINTED CIRCUITS and HARDWARE

Comprehensive range Constructors' Hardware and accessories

Selected range of popular components. Full range of ETI printed circuit boards, normally ex-stock, same day despatch at competitive prices.

P.C. Boards to individual designs. Resist-coated epoxy glass laminate for the d.i.y. man with full processing instructions (no unusual chemicals required).

Alfac range of etch resist transfers, and other drawing materials for p.c. boards.

Send 15p for catalogue.

**RAMAR CONSTRUCTOR
SERVICES**
MASONS ROAD
STRATFORD-ON-AVON
WARWICKS. Tel. 4879

COMPUTER HOBBIST, components at lowest prices. Write for free price list, stating your specific interests. PACS, 12 Alma Road, Monkstown, Co. Dublin, Eire.

**PLEASE MENTION ETI
WHEN REPLYING
TO ADVERTS**

COLOUR MODULATOR

Kit **£6.95** **FOR ALL TV GAMES!**
● Red, Green & Blue inputs ● Switchable background colours ● FREE Interface

Complete details for tank battles — lifelike effects

WILLIAM STUART SYSTEMS
137 Billericay Road, Herongate, Brentwood, Essex CM13 3SD
Telephone: (0277) 810244

STRATHAND SECURITY ALARMED?

If not you should be. We specialise in Alarm equipment suitable for home, office or factory. All items brand new top quality fully guaranteed.

- | | |
|---|--------|
| 101 Magnet and reed switch. Flush fitting. 4 wire. Requires hole 12mm diameter by 34mm deep | 90p |
| 102 Magnet and reed switch. Flush fitting screw terminals. Requires hole 15mm diameter by 14mm deep | £1.05 |
| 103 Magnet and reed switch. Surface fitting. 4 wire. Size 65mm by 13mm by 11mm | 90p |
| 104 Magnet and reed switch. Heavy duty. Size 103mm by 20mm by 13mm. Two hole fitting | £3.88 |
| 105 Pressure pad — stair tread 22½" x 6½" | £1.35 |
| 106 Pressure pad — large 29½" x 15" | £2.95 |
| 107 Window foil — self-adhesive — top quality. 70" roll by ½" wide. | £3.17 |
| 108 Foil blocks — self-adhesive (Joins foil to cable) | 19p |
| 110 Keyswitches with mounting plate and cover | £3.70 |
| 111 Bell boxes heavy duty plastic coated metal | £8.05 |
| 112 Bell 6" heavy duty — very loud 12v D.C. | £10.25 |
| 116 4 core cable 100mm — white | £10.75 |
| 123 Control panel to British Standard. Mains/battery, silent entry/exit. Anti-tube alarm circuitry | £46.40 |

All prices include VAT and postage

PLUS
Radar (microwave) units, automatic 999 dialling units with tape message, and many other items.

STRATHAND SECURITY
44 St. Andrew's Square
Glasgow, G1
Tel: 041-552 6731/2
Callers Welcome

MOTOROLA 6800 COMPUTERS

Single board 6800.17 command 1K Mikbug compatible Monitor, 1K user RAM, 1K Crystal Controlled VDU, CUTS, fully buffered, room for extra 3 x 2708 PROMS **£175.00**
Single board 2. Similar to above but with QWERTY keyboard **£205.00**
NEW Mini 6800 Two p.c.b. kit, 1K monitor, 1K VDU, RAM, CUTS, QWERTY keyboard **£145.00**
VDU kit. 1K Crystal controlled, memory mapped, parallel input video output. Should suit most processors **£60.00**

All prices include VAT and post. Please send SAE for leaflets. Mail Order only.

**HEWART
MICROELECTRONICS**
95 Blakelow Road
Macclesfield, Cheshire

LED PPM Single chip Peak Programme Meter (SN16880N) drives 5 LED's directly, easily cascaded to increase range/resolution. £3-50 ea inclusive. Applications sheets alone 18p. Peter Francis, 34 Ashley Dr., Twickenham TW2 6HW.

DIGITAL WATCHES. See my range of high quality L.C.D. watches and clocks all with 12 month guarantee from as little as £9 50. Send S.A.E. for colour brochure. D HULLAH (Watches), 14 Willow Grove, Harrogate, N/Yorks.

Sound to Light Fantastic!



Videograph II links to the aerial socket of your tv and provides a full colour oscilloscope display! A must for hi-fi, home entertainment, discos, organs etc.

New — signal invert control, integral square wave generator. **Plus** — full details for testing your audio system for transient distortion, crosstalk etc.

Complete Kit only £19.95 **Luxury cabinet and controls £9.95**

INC. POST, PACKING, VAT. READY BUILT VIDEOGRAPH £59.95
Dover House, Billerica Road
Herongate, Brentwood,
Essex CM13 3SD
WILLIAM STUART SYSTEMS Ltd Telephone Brentwood (0277) 810244

A GENUINE BARGAIN OFFER. LCD
Twenty Function Square Slim Chronograph. **CONSTANT DISPLAY:** Hours, Minutes, Seconds, A.M., P.M., Month, Date, Day, Roll-over, Backlight. **CHRONOGRAPH:** — Minutes, Seconds, 10th., 100th. Lap Time, Lap Indicator, Total Time, Return Ordinary Time, Freeze Time, Memory, Stainless Steel Locking Bracelet. 12 Month Guarantee. Money Back Guarantee. **ONLY £18.50.** Without Chronograph **£14.50.** To **J. RAMINGER**, 1 St. Laurence Way, Stanwick, Northants, NN9 6Qs.

WE'RE OUT TO FINISH YOU OFF!

Rapitape #
eti PANEL
TRANS

... or at least your projects. If there is one thing which is impossible to do at home is lettering front panels to professional standards. At least until now. If you cast your eyes right a while you'll see our new panel transfers sheet, which has been carefully designed to allow you to do exactly that.

The transfers are easily rubbed down, and the two sheet set contains a mass of lettering and —uniquely—control scales for both rotary and slider puts.

Each sheet measures 180mm X 240mm and comes packed flat in a stiff cardboard envelope for protection. There should be enough for dozens of projects here — and the longer you wait the worse they'll look!

Send **£1.75** (includes VAT and postage) for the two-sheet set to:
Panel Markings
ETI Magazine,
25-27 Oxford Street,
London W1R 1RF.

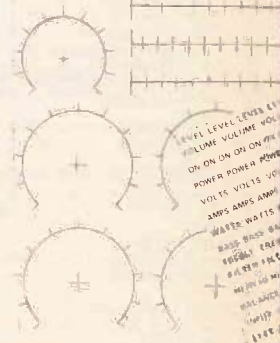

Teleplay presents the PROGRAMAGAME of all time!

TELEPLAY have produced a new product of easy to assemble cartridge games, for you and all your family, that will not go out of date. Just ADD each new cartridge, as it becomes available, and your colour video centre will be up to date the Teleplay way. You will save pounds in the long run. Works OK on Black and White TV.

EX-STOCK IMMEDIATE DELIVERY

Money back if not satisfied

We offer all this to you for ONLY **£28.90** + £2.31 VAT Fully Assembled £35.90

The Teleplay Kit consists of a Professional Finished Inject Moulded Box - Joystick Hand Controls - one cartridge which consists of 10 games - Football, Tennis, Solo Squash (1 & 2 players), Hockey, Basketball (1 & 2 players), Shoot etc. Mains Adaptor. All holes are pre-drilled - No Special equipment required. You'll be surprised how easy it is to assemble this professional kit! Instruction Manual supplied separately at 0.45p. TELEPLAY GIVES YOU TWICE THE FUN BUILDING AND PLAYING THE MOST PROFESSIONAL TV GAME KIT EVER OFFERED.



Main Console has 3 Facility Handicapping Switches.

Every 3 months a NEW game will become available to you and those already under production include Submarines, Space War, Wipe Out and many more. The price of these will vary from £12 to £19 depending upon the complexity of the game.

Additional cartridges NOW available include:

- Stunt Cycle - 4 games - Cartridges and Hand Controls - £14.90 + £1.14 VAT.
- Tank Battle - Cartridge and Hand Controls - £18.90 + £1.51 VAT.
- Road Race - 2 games - Cartridge - Controls already with basic kit - £12.90 + £1.03 VAT.

REALISTIC SOUND EFFECTS

All parts fully guaranteed.

Electrical knowledge is not a necessity to assemble this project - just simple soldering.

Cheques and Postal Orders to be made payable to TELEPLAY; send your order (No Stamp Needed) to Teleplay, Freeport, Barnet, EN5 2BR or telephone your order quoting your Barclaycard or Access number. Queries and Technical Advice offered either by phone or by calling at our shop.



SHOP OPEN - 10am to 7pm - Monday to Saturday
CLOSE TO NEW BARNET BR STATION - MOORGATE LINE

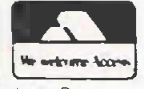

Watch this page each month for new cartridges, as they become available. All prices include Postage. Compare our prices with similar products in the big stores, which cost well over £100.



EUROPE'S LARGEST STOCKIST OF TV GAME COMPONENTS.

14 Station Road, New Barnet, Herts EN5 1QW Tel: 01-440 7033/01-441 2922

MAPLIN

everything for the modern D.I.Y. electronics enthusiast and more.

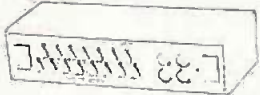

THE 'DRUMSETTE' RHYTHM GENERATOR
Organists, pianists, guitarists... an automatic drum set to accompany you! Nine highly realistic instruments play fifteen different rhythms. Fifteen rhythm-select touch switches and a touch plate for stop/start without rhythm change gives absolute ease of operation. Build it yourself for under £65 including smart teak-effect cabinet. See it and hear it in our shop! Send for full construction details now: MES49, price 25p.

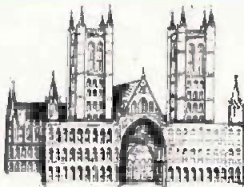

REVERBERATION SYSTEMS
High quality spring line driver module uses 4 integrated circuits and two transistors. Built and tested circuit board with wiring instructions for spring line. X8856, price £6.00. Power supply to suit drive module costs around £2.50 and construction details are in catalogue, or ask for leaflet MES24. Mechanical spring lines: Short line (X1084) £4.49; Long line (X884F) £10.39. (All prices include V.A.T. and p. & p.)



BOARDS AND PCB'S
Pages 59 to 61 of our catalogue show you our range of Veroboard and S-Boards or if you prefer to make your own pcb's a range of etching systems including the novel etch-in-a-bag system, plus printed circuit transfers for the professional finish to your boards.



9-CHANNEL RADIO CONTROL SYSTEM
A comprehensive model control system, featuring nine independent fully proportional channels achieved by a design using very few components thus keeping the cost to a minimum. Full construction details in our booklet (XF030) price £1.20.

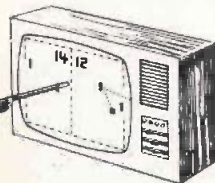

T.V. GAME
A fascinating TV game kit that plays football, tennis, squash and practice for only £215.99. Reprint of construction details 25p. Add on rifle kit only £10.60. (All prices include V.A.T. and p. & p.)

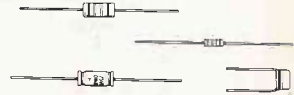

MASSIVE RANGE OF COMPONENTS
For instance the capacitor section in our catalogue includes non-polarised electrolytics and our resistor section includes even 1% tolerance types. Get our fascinating catalogue now — you won't regret it.



AUDIO MIXER
A superb stereo audio mixer. It can be equipped with up to 16 input modules of your choice and its performance matches that of the very best tape recorders and hi-fi equipment. It meets the requirements of professional recording studios, FM radio stations, concert halls and theatres. Full construction details in our catalogue. A component schedule is available on request.



ELECTRONIC ORGAN
The only organ you can build in stages and tailor to your requirements as you go along — and at each stage you'll have a fully working instrument! We haven't got the gimmicks yet — (they're coming soon) but we have got the most beautiful sounds — you won't find them on any organ less than twice our price. So get our MES50 series leaflets now! 65p buys the three available so far.



MICROPROCESSOR
Build a mini-computer with our microprocessor kit. Features: 48 different instruction types; 256 bytes of read/write memory (more are easily added); microprocessor can address up to 65,536 8 bit bytes. Complete kit for use with teletype etc. (X891Y) £74.10. 20-key keyboard for use with above (no place of teletype) (X892A) £71.11. Both kits with detailed instruction books. See our newsletter for details of additional RAM's, tri-state interfacing chips, number-cruncher and standard cassette tape-recorder interface to store your programmes. (All prices include V.A.T. and p. & p.)



Our bi-monthly newsletter keeps you up to date with latest guaranteed prices — our latest special offers — details of new projects and new lines. Send 30p for the next six issues (5p discount voucher with each copy).



★ Come and see all our projects on display at the Electronics hobby show 'Breadboard' at Seymour Hall, London W1 stands E7-E9. ★

POST THIS COUPON NOW FOR YOUR COPY OF OUR 1979-80 CATALOGUE PRICE 75p

Please rush me a copy of your 216-page catalogue I enclose 75p, but understand that if I am not completely satisfied I may return the catalogue to you within 14 days and have my 75p refunded immediately.

NAME _____
ADDRESS _____

MAPLIN ELECTRONIC SUPPLIES
P.O. BOX 3 RAYLEIGH ESSEX SS6 8LR
Telephone: Southend (0702) 715155
Shop: 284, London Road, Westcliff-on-Sea, Essex
(Closed on Monday) Telephone: Southend (0702) 715157