

**ELECTRONICS
ILLUSTRATED**

C. Sears

560
A
**FAWCETT
BOOK**

ELECTRONICS

HANDBOOK • No. 3

GENERAL EXPERIMENTER

- Electronic Target Shoot
- Protect Your Family With an Electronic "Watch Box"
- Build Your Own AC Generator

AMATEUR RADIO

- Build a Code Practice Set
- Antenna Analyzer • Memory Box for Hams
- Want to Be a Junior Ham?



CB Service Set



Telephone Bell Extension

CITIZEN'S BAND

- CB Signal Booster • Crystal Checker
- Automatic Transmit / Receive Switching
- Voice Power Amplifier • Ampli Mike

AUDIO

- Go Stereo the Easy Way
- How to Make a Mike • Stereo Balancer
- Master TV / FM Antenna System



75¢

World Radio History

Build an Automatic Code Sender

CHRISTY'S *Complete* ELECTRONIC COURSE

Learn

TELEVISION, RADIO, RADAR, SONAR, ELECTRONICS

Only CTS offers you **COMPLETE** training in all phases of Electronics. Why be satisfied with less? The new Christy Shop-Method Home Training makes learning interesting and easy. You learn Radar, Sonar, Electronics, Radio, Television. No previous experience needed. You learn by working with actual equipment. Makes learning fun. Speeds your progress. Helps you understand quicker and remember longer.

You get comprehensive training starting with your first CTS lesson! The complete knowledge CTS provides you with, gives you a broader knowledge, a greater understanding which will mean more jobs and a higher income for you for the rest of your life.

HOME LABORATORY SENT! 19 TRAINING INSTRUMENTS INCLUDED

With CTS **COMPLETE** Home Training Course, you receive a Home Laboratory to assemble, use and keep for years of peak performance. You receive a Multi-Tester, Oscillator, Signal Tracer, Oscilloscope, Signal Generator, Electronic Timer, Regenerative Radio, Giant-size Television Receiver (optional) as well as many other valuable electronic devices. With these you will be able to make hundreds upon hundreds of exciting experiments.

EARN WHILE YOU LEARN! EARN \$5.00—\$6.00 PER HOUR

Or **MORE** while still studying! Almost from the very first you receive training that enables you to repair radios and television sets for friends and neighbors. To install and service electronic computers, communication equipment, protective equipment for police and fire departments, etc., etc.

FREE BOOK—SAMPLE LESSONS SENT

Get all there is to know about the Christy **COMPLETE** Electronic Course in Radio-Television-Radar-Sonar, etc. A complete, colorful, illustrated book on Electronics sent without obligation.

Also, we will send you Two sample lessons showing how the new CTS Shop-Method Home Training Course will train you for making big money in your spare time and for building a bright future for yourself.

CHRISTY TRADES SCHOOL, Dept. T-141, 3214 W. Lawrence Ave., Chicago 25

SIGN, MAIL FOR THREE BOOKS

Christy Trades School, Dept. T-141, 3214 W. Lawrence Ave., Chicago 25, Ill.

Gentlemen:

Please send me, without cost or obligation, two **FREE** lessons and the new 24-Page Illustrated book telling all about the CTS Master Shop Method Home Training Course in Radar, Sonar, Television, Radio and Electronics, and the many opportunities this new field offers.

Name..... Age.....

Address

City..... Zone.... State.....

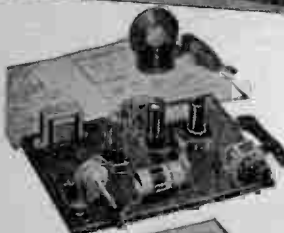

**MAIL COUPON
TODAY FOR
CATALOG !**



DeVry Stands Behind Every Man It Trains

**These Opportunity
Packed Fields
Need YOU!**

- Space & Missile Electronics
- Television & Radio
- Microwaves
- Automation Electronics
- Radar
- Communications
- Computers
- Broadcasting
- Industrial Electronics

Count-down, blast-off, orbital communication! Back of every space-age achievement is the magic of electronics. And back of most electronic applications — in space, in the industrial plant, studio, or laboratory — is the electronics technician. Thousands of technicians have been trained by DeVry Technical Institute since 1931 and back of each man stands the school that has trained him. Yes, DeVry Tech backs him with continuing Employment Service through the years of his career; DeVry backs him with its practical Consultation Service, helping him solve technical problems he may meet, on his job, at any time. All this tops off DeVry's practical training: at home in spare time, or full or part-time in DeVry's modern, well equipped training centers in Chicago or Toronto. If you're 17-55, find out all that DeVry has to offer you in the exciting field of electronics.

YOU'VE NOTHING TO LOSE, YOU'VE MUCH TO GAIN! MAIL COUPON NOW!



Accredited member of National Home Study Council

DeVry --- Tops in Electronics
Chicago — Toronto

DeVRY TECHNICAL INSTITUTE
4141 Belmont Ave., Chicago 41, Ill., Dept. EG-4-U

Please give me your two free booklets, "Pocket Guide to Real Earnings" and "Electronics in Space Travel"; also include details on how to prepare for a career in Electronics. I am interested in the following opportunity fields (check one or more):

- | | |
|--|---|
| <input type="checkbox"/> Space & Missile Electronics | <input type="checkbox"/> Communications |
| <input type="checkbox"/> Television and Radio | <input type="checkbox"/> Computers |
| <input type="checkbox"/> Microwaves | <input type="checkbox"/> Broadcasting |
| <input type="checkbox"/> Radar | <input type="checkbox"/> Industrial Electronics |
| <input type="checkbox"/> Automation Electronics | <input type="checkbox"/> Electronic Control |

Name _____ Age _____

Address _____ Apt. _____

City _____ Zone _____ State _____

- Check here if you are under 16 years of age.
Canadian residents: Write DeVry Tech of Canada, Ltd.
2083 970 Lawrence Avenue West, Toronto 19, Ontario

ELECTRONICS HANDBOOK

NO. 3

A FAWCETT BOOK • NUMBER 560
 LARRY EISINGER • EDITOR-IN-CHIEF
 GEORGE TILTON • MANAGING EDITOR
 SILVIO LEMBO • ART EDITOR
 NICK CARLUCCI • ASSOC. ART EDITOR

W. H. Fawcett, Jr. President
 Roger Fawcett General Manager
 Donald P. Hanson Assistant General Manager
 Gordon Fawcett Secretary-Treasurer
 Roscoe Fawcett Circulation Director
 Ralph Daigh Editorial Director
 Mortimer Berkowitz, Jr. Advertising Director
 Al Allard Art Director
 Ralph Mattison Associate Art Director
 George H. Carl Production Director

JOSEPH PIAZZA EDITOR

HAROLD E. PRICE ASSISTANT ART EDITOR
 Mike Gaynor • John Selvaggio
 Bob Vatter • Richard Rhodes
 Bernie Clorman • Alex Santiago

Helene Finkel Production Editor
 Stacey Winter Assistant Production Editor

ELECTRONICS HANDBOOK NO. 3, Fawcett Book 560, is published by Fawcett Publications, Inc., Greenwich, Conn. Editorial and Advertising Offices: 67 West 44th Street, New York 36, New York. General Offices: Fawcett Building, Greenwich, Connecticut. Printed in U.S.A. Copyright © 1964 by Fawcett Publications, Inc.

Cover photos by Grayson Tewksbury, Fawcett Studios.

Fawcett Publications, Inc., is a member of American Book Publishers Council, Inc.

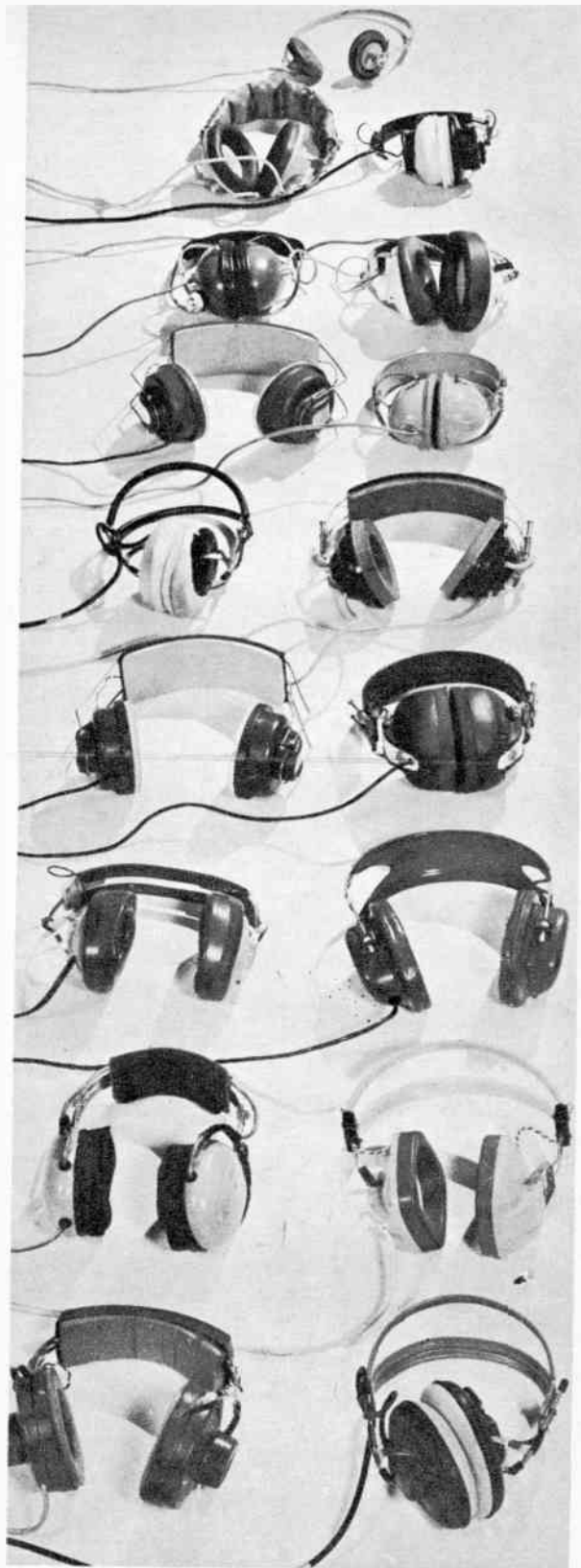

HOW TO BREAK INTO RADIO-TV-ELECTRONICS

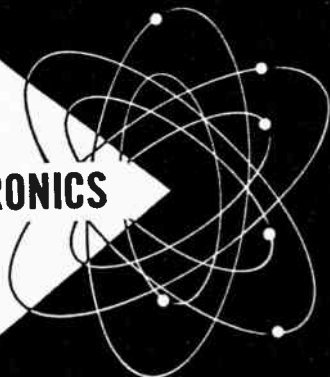

A good paying career in Radio-TV-Electronics may be closer than you think—regardless of your age, education or present job experience.

You know about the tremendous demand for radio-TV and electronics technicians. But something perhaps you didn't know is how easy it is to get the training that will qualify you for this vital work, and how quickly you can advance.

From the very beginning you will find that your I.C.S. course is preparing you thoroughly—at your own pace—for an exciting new career. I.C.S. Radio-TV-Electronics courses make electronic fundamentals clear, easy to follow. You get *personalized* guidance from people who know—and can tell you—what it takes to succeed along every step of the way.

The I.C.S. method makes it possible to learn while you earn. You study at home—in your spare time. Everything you learn is practical, usable. Your mastery of Radio-TV-Electronics assures you of top

pay and real job security in one of today's fastest growing fields.

So if you would like to break into Radio-TV-Electronics—your first step is to send for your **FREE I.C.S. Career Kit**. There's no obligation . . . and there's a whole new future to gain.

Send coupon below for your
free I.C.S. Career Kit!



"How to Succeed" career guide

"Career Catalog" of job opportunities in your field of interest

"Sample Lesson" (math) to demonstrate the famous I.C.S. method



Accredited Member,
National Home Study Council

For Real Job Security—Get an I.C.S. Diploma!

I.C.S., Scranton 15, Penna.

INTERNATIONAL CORRESPONDENCE SCHOOLS



BOX E1502D, SCRANTON 15, PENNA.

In Hawaii reply P.O. Box 418, Honolulu

(Partial list of courses)

Without cost or obligation, send me "How to Succeed" and the opportunity booklet about the field BEFORE which I have marked X (plus sample lesson):

RADIO TELEVISION ELECTRONICS

- General Electronics Tech.
- Industrial Electronics
- Practical Radio-TV Eng'r'g
- Practical Telephony
- Radio-TV Servicing

BUSINESS

- Cost Accounting
- Managing a Small Business
- Purchasing Agent

DRAFTING

- Electrical Drafting

HIGH SCHOOL

- High School Diploma
- Good English
- High School Mathematics

ELECTRICAL

- Electrical Engineering
- Elec. Engr. Technician
- Elec. Light and Power
- Practical Electrician
- Professional Engineer (Elec.)

LEADERSHIP

- Industrial Foremanship
- Industrial Supervision
- Personnel-Labor Relations
- Supervision

Name _____ Age _____ Home Address _____
 City _____ State _____ Zone _____ Working Hours _____ A.M. to _____ P.M.
 Occupation _____

Canadian residents send coupon to International Correspondence Schools, Canadian, Ltd., Montreal, Canada. . . . Special low monthly tuition rates to members of the U. S. Armed Forces.

CONTENTS

AMATEUR RADIO

Telegraph Key	6
Antenna Analyzer	12
An Automatic Code Sender	17
Want to Be a "Junior Ham"?	37
Memory Box for Hams	50
Deluxe Your Heath Sixer	77
Command Control Center	96

CITIZENS BAND RADIO

SWR Meter for CB	8
CB Signal Booster	30
The COM-VOX	33
6-in-1 CB Service Set	41
The Ampli Mike	51
CB Crystal Checker	54
Voice Power Ampli	59

GENERAL EXPERIMENTER

The Battery Analyst	24
Low-Cost Direction Finder	27

Hike That "Q"	45
The "Mini R"	56
Build Your Own AC Generator	58
Electronic Watch Box	62
SCR Speed Control	66
Applying Heat with Precision	68
Photoconductor Projects	71
<i>Target Shoot for Game Room</i>	73
<i>Model Railroad Crossing Guard</i>	73
Magic Eye Wattmeter	81
Telephone Bell Extension	84
Handyman's Cable and Pipe Finder	87
3-Band Mainmast	90
SWL Antenna Tuner	94

AUDIO

Going Stereo the Easy Way	48
Master TV Antenna System	74
How to Make a Mike	80
The Stereo 120	100
Stereo Balancer	110



Learn More • Learn Faster • Learn Better through bonafide

master
mathematics
in your leisure

PROGRAMMED LEARNING

exclusive with **Britannica Schools**
a member of the Encyclopaedia Britannica Family

THESE 14 CLASSROOM-TESTED COURSES IN THE GENUINE "TEACHING MACHINE" APPROACH
BASIC MATHEMATICS • WHOLE NUMBERS AND NUMERALS •
ALGEBRA I • ALGEBRA II • PLANE GEOMETRY • SOLID GEOMETRY
• THE LANGUAGE OF ALGEBRA • TRIGONOMETRY • ANALYTIC
TRIGONOMETRY • INTRODUCTORY CALCULUS I & II • MANAGE-
MENT DECISION MAKING • VERBAL PROBLEMS • INTRODUCTION TO
SETS, INEQUALITIES AND FUNCTIONS • DESCRIPTIVE STATISTICS

Not a "scrambled book" or miniature gadget promising only "review" or "highlights" from a box.

Here is the full, traditional curriculum of mathematics, presented only after classroom testing on thousands of high school students.

You will find not just "2,000 simple steps," but 6,000 . . . 8,000, or in some areas more than 11,000 carefully developed and re-searched frames of information.

You have read about "the Roanoke, Virginia" startling success with 34 ordinary 8th grade pupils completing a full 9th grade Algebra course in less than a semester. This Britannica Schools material is the only material they used.

Now, this identical material, as prepared by

world famous Encyclopaedia Britannica experts, and as used in Roanoke, and hundreds of other high schools and colleges throughout the nation, can be yours for study in your own home.

You get the complete programmed course that permits you to progress at your own rate of speed in the privacy of your own home. You take periodic tests of your progress as you study under the guidance of your own Britannica Schools tutor.

This is no "do-it-yourself" short cut. This is a full, academic and completely tested method of programmed learning by the leading researchers and producers of programmed learning materials. You will grasp more material more quickly than by taking any other math course.

For full details on any Britannica Schools course in mathematics, fill out and send us the coupon, today. No obligation. **SOLD ONLY THROUGH THE MAIL.**

Britannica Schools
Division of Encyclopaedia Britannica Press, Inc.
14 East Jackson Boulevard
Chicago 4, Illinois
Dept. 105

NO OBLIGATION . . . ACT TODAY

Please send me full details on the course(s) I have checked. I understand there is no obligation.

Basic Mathematics Whole Numbers and Numerals
 Algebra I Algebra II Plane Geometry
 Solid Geometry The Language of Algebra
 Analytic Trigonometry Introductory Calculus I & II
 Trigonometry Management Decision Making
 Verbal Problems Introduction to Sets, Inequalities and Functions
 Descriptive Statistics

Name _____
Address _____
City _____ Zone _____ State _____
Age _____ Occupation _____

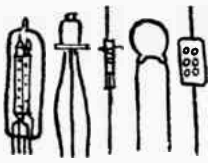

BEGINNERS PAGE

TELEGRAPH KEY

A MUST for learning and practicing Morse code is a code-practice set. Putting together your own is an interesting project if you build your key. After you learn code, you can build a code-practice oscillator (CPO).

The key shown here is constructed of materials you're likely to have around the house. The buzzer and batteries that you will have to buy will run the whole bill for materials to less than a dollar. The key should be built on a wooden base cut to the dimensions shown. If you have a piece of composition peg-board, so much the better. The punched holes in the material eliminate drilling.

Mount the $3\frac{1}{4} \times \frac{1}{2}$ inch metal strip first. Best metals for the job are aluminum or copper sheet. But any other metal will work as the moving arm of the key, if it is springy. The handle is a wooden radio knob or some other round piece of material attached to the metal strip with a wood screw.

If you use a knob with a $\frac{1}{4}$ -inch shaft hole, offset the wood screw slightly so the knob will be centered.

After the strip and knob are in place, add the lower contact. A 6-32 machine screw positioned just under the key handle will do the job. The head of the wood screw must strike the lower contact when the handle is pressed down.

The buzzer is a 1.5-volt type (Lafayette MS-437). Two batteries, providing 3 volts, are used. This improves

keying action and does not harm the buzzer. Alternatively, an old household buzzer may be used, but the voltage must be increased to about 6 volts. Four D cells connected in series (end to end) will provide this voltage.

After wiring is completed, you're ready to adjust the key. Slide a small block of sponge or foam rubber under the metal strip. This provides the spring action necessary for proper feel. Once in place, the block can be slid back and

forth to change the tension on the metal strip. Adjust it according to your preference, but don't allow spacing of the key contacts to exceed about an eighth of an inch.

Learn to operate your key properly. With your forearm resting on the table, lower your hand so your first three fingers

fall onto the key handle. Above all, don't squeeze the handle. To send, move your wrist up and down with a bouncing motion. This action is transmitted to the handle, which touches the lower contact and forms code characters.

Wrist action alone should close the key contacts. Avoid the usual tight finger approach and you won't develop a case of key cramps.

After you have learned the code and have the sending technique down pat, you can advance to a commercially manufactured key. They have more refined adjustments that enable you to regulate the key's action to suit your touch preference.—H. B. Morris

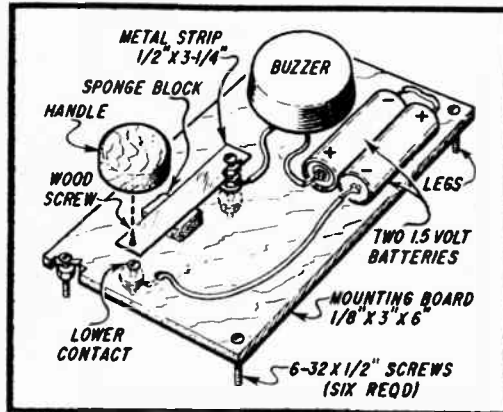

**Stop wasting time in a dead-end job!
 Enjoy the big rewards offered the
 law-trained man in business**

STUDY **LAW**

IN YOUR SPARE TIME
as a way to
increased earnings



WHATEVER your present position — whatever your previous schooling — you can multiply your opportunities for rapid promotion, big income and prestige through LaSalle law training at home.

A knowledge of Law is regarded today as indispensable equipment in every activity of business. The greatly increased role of government in business, the many new problems of Law involving taxes, insurance, contracts, liability, employment, and much more — all require the legally-trained executive who can make day-to-day decisions effectively. That is why leading corporations seek out such men for key positions and reward them with top salaries.

You can master Law easily and enjoyably at home — at remarkably low cost — under the supervision of LaSalle's distinguished Law faculty. Your study is illustrated with actual legal cases. Upon completion of your training, you are awarded a Bachelor of Laws degree if qualified. *The famed LaSalle Law Library of 14 volumes is given to you as part of your course.*

**Send
 for
 this
 Free
 Book-
 let**

For over half a century LaSalle has been an acknowledged leader in business training, with more than 1,000,000 students. Send for the free booklet "Law Training for Leadership" and see how LaSalle can help you move up rapidly in business. Address: 417 So. Dearborn, Chicago, Illinois 60605.

LA SALLE **EXTENSION UNIVERSITY**

A Correspondence Institution

417 S. Dearborn, Dept. 28-060, Chicago, Illinois 60605

Please send me, free of cost or obligation, your illustrated booklet "Law Training for Leadership."

Name.....Age...

Address.....County.....

City & Zone.....State.....

Occupation.....Working Hours...A.M....P.M.

221 Canadian residents: LaSalle, Box 1001, Montreal 3.

SWR

METER FOR CB

By David Walker

BEEN getting poor signal reports from your own mobile and other Citizens Band stations? Before you set about retuning your final or installing a new RF output tube, consider your antenna and transmission line. A mismatched antenna system sets up what are called standing waves on the line and wastes watts by reflecting power back to the transmitter. Knock down the SWR (standing-wave ratio) and the signal from your antenna goes up.

An SWR meter will tell you how well your antenna, transmission line and transceiver are matched. It will reveal coax cable that's withering from the weather and disclose damaged antenna elements. It will enable you to determine the exact length for mobile antennas having adjustable elements. It will show you when a home-brew antenna is perfectly matched to the line. Finally, it will permit you to make periodic checks of the entire antenna system.

Calibration and Use. The SWR meter should be calibrated each time it is to be used. Though CB antennas are rated at 50 or 52 ohms, calibration with a 51-ohm resistor (the nearest standard value) will prove sufficiently accurate.

Connect your transceiver's output to J1 and the 51-ohm resistor between the shell and the center pin of PL1. Set the transceiver to transmit and adjust sensitivity control R4 so the meter deflects full scale. Do this quickly or the 51-ohm resistor may overheat.

Next, plug PL1 into the transceiver's output jack and connect the 51-ohm resistor between the shell and center lug of J1. When you turn on the transceiver, the SWR meter should indicate about zero. Remove the resistor and insert your antenna plug into J1. If the antenna and line are in good condition, they will present about the same load to the meter as the 51-ohm calibrating resistor; the meter should stand near zero.

To simplify construction, the meter was designed to give relative readings only. That is, make adjustments to the antenna system to produce the lowest meter indication. However, the SWR can be determined approximately from the table on the next page.

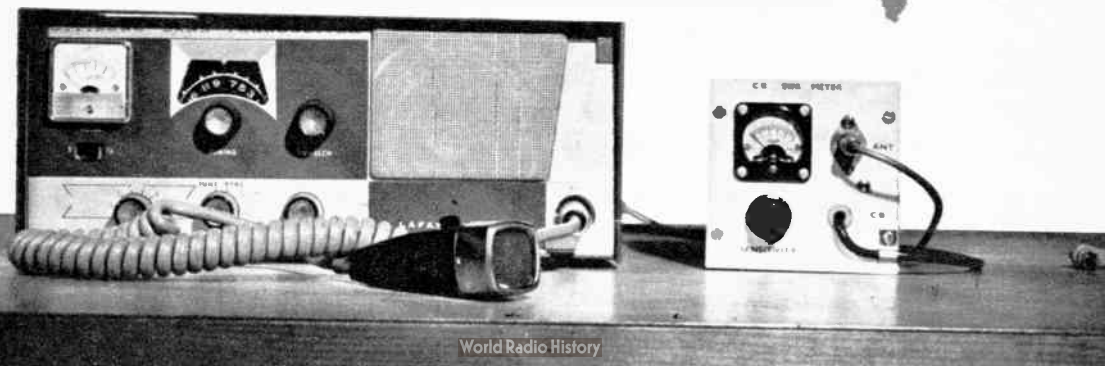

Exclusive with **RCA** ...

AUTOTEXT®

new, faster, easier way toward a career in electronics

EXCLUSIVE WITH RCA. "AUTOTEXT," developed by RCA and introduced by RCA Institutes, Inc., is a system of programmed instruction, accurately planned so that as you read a series of statements, questions, and answers, you learn almost without realizing it! It's fast! It's easy! It's fun!

NEW TREND IN EDUCATION! Programmed instruction has been proved with thousands of students. People who have had trouble with conventional home training methods in the past can now master the fundamentals of electronics almost automatically!

PROVE IT TO YOURSELF NOW! An interest or inclination in electronics is all you need. RCA "AUTOTEXT" will help you do the rest. And the future is unlimited; the jobs are available! The important thing is to get started now!

COMPLETE COURSE AVAILABLE. RCA Institutes now offers you a complete Home Training Course ("Introduction to Electronics") using the "AUTOTEXT" method. You get a complete set of theory lessons, service practice lessons, experiment lessons, and all the kits you need. You'll learn faster with less effort!

Complete selection of Home Training Courses, in addition to "AUTOTEXT"-Introduction to Electronics.

- Electronic Fundamentals (also available in Spanish)
- TV Servicing
- Color TV Servicing
- Communications Electronics
- FCC License Preparation
- Mobile Communications
- Computer Programming
- Electronic Drafting
- Automation Electronics
- Transistors
- Industrial Electronics
- Automatic Controls
- Industrial Applications
- Nuclear Instrumentation
- Digital Techniques

All RCA Institutes Home Training Courses are complete step by step easy-to-understand units. You get prime quality equipment in the kits furnished to you to keep and use on the job. In addition, RCA's liberal tuition plan affords you the most economical possible method of home study training. You pay for lessons only as you order them. If you should wish to interrupt your training for any reason, you do not owe one cent. Licensed by the N.Y. State Department of Education. Approved for Veterans.

FREE OFFER!

We'll send you complete information on the amazing new RCA "Autotext", along with a FREE SAMPLE of a Home Training lesson to prove to you how easy it is to learn this new way. Check "Autotext", and information will be rushed to you.

Classroom Training Available in New York City, and Cherry Hill (near-Camden) New Jersey.

Check "Classroom Training" and we will rush information.



RCA INSTITUTES, INC., Dept. EG-44
A Service of Radio Corporation of America 350 West 4th St., New York 14, N. Y.

The Most Trusted Name in Electronics

RCA Institutes, Inc. Dept. EG-44
350 West 4th St., New York, N.Y. 10014

Please rush me FREE illustrated book with information checked below. No obligation. No salesman will call.

Home Training (choice of courses) _____

Classroom Training (choice of city) _____

Name _____ Age _____

Address _____

City _____ State _____ Zip _____

CANADIANS: Take advantage of these same RCA Institutes Courses at no additional cost. No postage, no customs, no delay. Fill out coupon and send in envelope to: RCA Victor Ltd., 5581 Royalmount Ave., Montreal 9, Quebec.

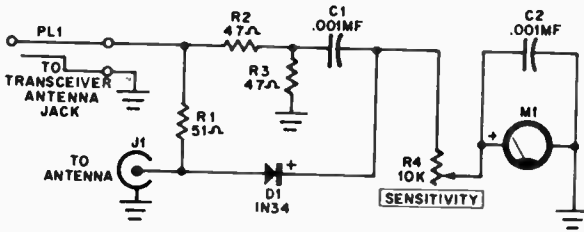

Schematic of bridge which indicates the lowest SWR rather than the absolute value of SWR. When making antenna adjustments, the object is to obtain readings as close as possible to a null or zero.

R2 and R3 are mounted at right angles to each other. Transfer of energy between these components, which compare voltages to and from antenna, leads to inaccurate readings. Leads from R2, R3 and C1 are twisted together and soldered and not connected to a terminal strip. Anchor point for incoming coaxial cable is a two-lug terminal strip with one lug serving as a ground for the shield (scrape paint from panel for good grounds). Dress shield close to coax jacket to prevent shorting hot lug. Choice of plug and jack depends on your CB transceiver. Author's model uses auto-radio connectors. Use coax type for PL1, J1 to match those on your rig.

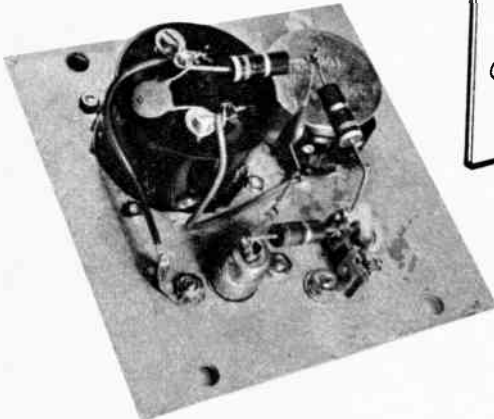
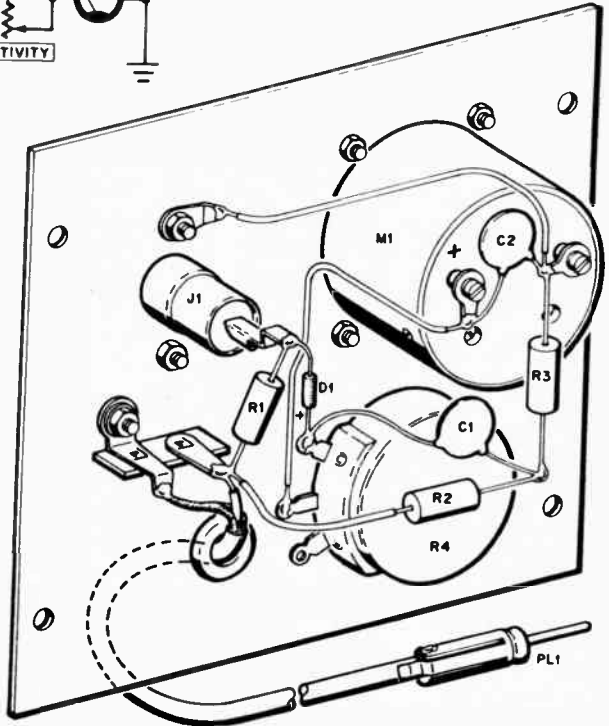

- PARTS LIST**
- R1—51-ohm, 1-watt, 5% resistor
 - R2, R3—47-ohm, 1-watt, 5% resistor
 - R4—10,000-ohm carbon potentiometer
 - C1, C2—.001 mf, 500 V ceramic disc capacitor
 - D1—IN34 diode
 - M1—0-1 ma DC milliammeter
 - PL1—Antenna plug (to match CB transceiver output jack)
 - J1—Antenna jack (to match CB antenna plug)
 - Misc—51-ohm, 1-watt, 5% calibrating resistor, 4x4x2-inch aluminum cabinet (Premier AC-442 or equiv.), two-foot length of RG58/U coaxial cable.

For practical purposes, an SWR of 2:1 or less is acceptable. Lost power at this value is negligible. Since the chart is only a rough guide, it's best to determine your own reference. After calibrating

Meter Indication (ma)	SWR
0	1:1
.2	1.5:1
.3	2:1
.4	2.5:1
.5	3:1

the meter, note the reading. Future checks should produce about the same reading if the antenna system is good.

To use the SWR meter for determining antenna length or for antenna adjustment, you'll need a field-strength meter. The technique is to peak the transmitter's final while watching the field-strength meter. Then adjust the antenna's length for lowest SWR and retune the transceiver if necessary.

A NEW WORLD OF OPPORTUNITY AWAITS YOU WITH N.T.S. ALL-PHASE HOME TRAINING IN ELECTRONICS



You can install and maintain electronic circuitry in missiles and rockets... specialize in micro-waves, radar and sonar.



You can succeed in TV-Radio Communications... prepare for F.C.C. License, service advanced satellites for industry and defense.



You can service and repair the electronic "brains" of industry—computers, data processing, and other automation equipment.



You can become a highly-paid TV-Radio Technician, an electronics field engineer, or succeed in your own sales & service business.

The N.T.S. Master Course enables you to do more, earn more in ELECTRONICS • TELEVISION • RADIO

Yet N.T.S. Training costs no more than other courses far less complete

There's a good reason why N.T.S. Master-Training opens a wide new world of opportunity for you in Electronics, Television, Radio.

Everything you learn, from start to finish, can be applied directly to all phases of the Electronics Industry.

As a result, the N.T.S.-Trained Technician can move ahead faster, in any direction — from TV-Servicing to Radio Communications to Space-Missile Electronics and Automation for industry and defense. You can go wherever pay is highest and opportunity unlimited.

Electronic circuitry, for example, is one of science's miracles that is basic to the entire field of Electronics. It is used in satellites, computers and space capsules as well as in today's television sets and high fidelity equipment. N.T.S. shows you how to service and repair electronic circuitry for all electronic applications.

YOU WORK ON MANY PRACTICAL JOB PROJECTS.

You build a short-wave, long-wave superhet receiver, plus a large screen television set from the ground up. N.T.S. training kits contain all the parts you need, at no extra cost. (See box at right.) You also receive a professional Multimeter to use during training and on the job.

ONE LOW TUITION. You need training related to all phases of Electronics. Industry demands it. Only N.T.S. provides it... in ONE Master Course at ONE low tuition.

RESIDENT TRAINING AT LOS ANGELES

If you wish to take your Electronics-TV-Radio training in our famous Resident School in Los Angeles — the oldest and largest school of its kind in the world — write for special Resident School catalog and information, or check coupon.



NATIONAL TECHNICAL SCHOOLS

WORLD-WIDE TRAINING SINCE 1905
4000 So. Figueroa St., Los Angeles 37, Calif.



YOU ENROLL BY MAIL AND SAVE MONEY. No salesman means lower costs for us, lower tuition for you.

START NOW. A whole new world of opportunity awaits the man with Electronic Home-Training from National Technical Schools — a recognized leader in technical training for 58 years.



19 BIG KITS
YOURS TO KEEP

ACTUAL LESSON

MAIL COUPON NOW FOR FREE BOOK AND ACTUAL LESSON!

NO OBLIGATION.
NO SALESMAN WILL CALL.

NATIONAL TECHNICAL SCHOOLS
WORLD-WIDE TRAINING SINCE 1905

National Technical Schools, Dept. R6H-44
4000 S. Figueroa St., Los Angeles 37, Calif.

Please Rush **FREE** Electronics-TV-Radio "Opportunity" Book and Actual Lesson. No Salesman Will Call.

Name _____ Age _____

Address _____

City _____ Zone _____ State _____

Check if interested **ONLY** in Resident Training at L.A.

High school home study courses also offered. Check for free catalog.

For more sock in your signal, build our

ANTENNA ANALYZER

By Herb Friedman, W2ZLF

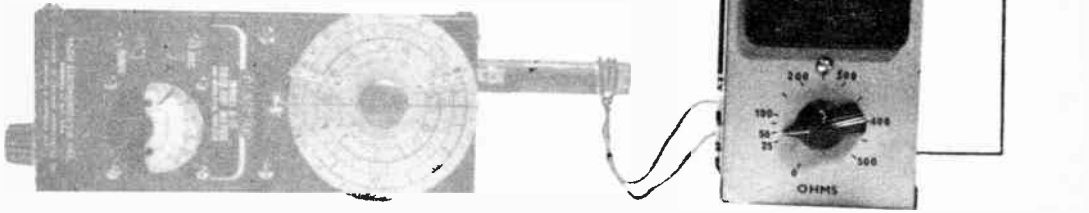

W E know a fellow who abandoned his ham gear for a while to spend his time sticking pins into the effigy of his next-door neighbor. Why? Because the neighbor's flea-power rig outperformed his super-duper, high-priced outfit every time.

If he had spent less time with the pins our friend might have realized all he had to do was get his antenna system tuned to a razor's edge. Think it's a task to be dreaded? Well, listen. EI's Antenna Analyzer can determine antenna and feedline resonance, system impedance, SWR and radiation resistance.

The Analyzer (which may also be used by CBers) requires an input signal which can come from your VFO (variable-frequency oscillator) or GDO (grid-dip oscillator). A one- or two-turn coil placed near one of your transmitter's low-power stages or near the output tank of a CB rig will pick up a sufficient signal for the Analyzer.

The Analyzer's range extends up to 30 mc and it will work with twinlead or open-wire line. If you use coaxial cable, build the adaptor shown or replace SO2 with a coax connector.

Construction. Except for M1 and SO2, use the components specified. If you use short direct leads and are careful about parts placement, the range can be extended up to 54 mc. But on 2-meters, both M1 and R2 must be indi-

vidually shielded with aluminum foil. Mount M1 as close as possible to the top of the U-section of a 5¼x3x2 ½-inch Minibox.

M1 should be at least a 200-micro-ampere meter. If you can afford a 100-microampere meter, so much the better.

R2 must be insulated from the cabinet with a half-inch length of ⅜-inch I.D. plastic tubing. Cut the tubing so the ends are squared off. Coat R2's mounting bushing with Q-dope, taking care that it does not get into the control. Push the insulator onto R2's bushing (screw the mounting nut all the way on R2 first) and set it aside for a few hours. When the Q-dope is half-hard, carefully unscrew the plastic tubing and let the Q-dope in it dry overnight. When the Q-dope dries, one end of the tubing will have threading molded in it. Re-coat R2's bushing with Q-dope and force the *unthreaded* end of the plastic insulator on R2. When the Q-dope dries, the insulator will be permanently attached to R2. Then push the plastic shaft into R2 and fasten the assembly to the panel with a standard ⅜-inch panel bushing as shown in the pictorial on the last page of this story.

Position input connector SO1 and antenna socket SO2 so their lugs line up with R2's terminals. Make certain D1's polarity is correct and take care that it is not overheated when soldering. Com-

BUILD YOUR OWN RADIO

CIRCUITS AT HOME

ONLY \$26.95

with the new PROGRESSIVE RADIO "EDU-KIT"®

A Practical Home Radio Course

Now Includes

- ★ 12 RECEIVERS
- ★ 3 TRANSMITTERS
- ★ SQ. WAVE GENERATOR
- ★ SIGNAL TRACER
- ★ AMPLIFIER
- ★ SIGNAL INJECTOR
- ★ CODE OSCILLATOR

- ★ No Knowledge of Radio Necessary
- ★ No Additional Parts or Tools Needed
- ★ EXCELLENT BACKGROUND FOR TV
- ★ School Inquiries Invited
- ★ Sold In 79 Countries



Training Electronics Technicians Since 1946

YOU DON'T HAVE TO SPEND HUNDREDS OF DOLLARS FOR A RADIO COURSE

The "Edu-Kit" offers you an outstanding PRACTICAL HOME RADIO COURSE at a rock-bottom price. Our Kit is designed to train Radio & Electronics Technicians, making use of the most modern methods of home training. You will learn radio theory, construction practice and servicing. THIS IS A COMPLETE RADIO COURSE IN EVERY DETAIL.

You will learn how to build radios, using regular schematics; how to use an solder in a professional manner; how to service radios. You will work with the standard type of punched metal chassis as well as the latest development of Printed Circuit chassis.

You will learn the basic principles of radio. You will construct, study and work with RF and AF amplifiers and oscillators, detectors, rectifiers, test equipment. You will learn and practice code, using the Progressive Code Oscillator. You will learn and practice trouble-shooting, using the Progressive Signal Tracer, Progressive Signal Injector, Progressive Dynamic Radio, & Electronics Tester, Square Wave Generator and the accompanying instruction material.

You will receive training for the Novice, Technician and General Classes of F.C.C. Radio Amateur Licenses. You will build 20 Receiver, Transmitter and Square Wave Generator, Code Oscillator, Signal Tracer and Signal Injector circuits, and learn how to operate them. You will receive an excellent background for television, Hi-Fi and Electronics.

Absolutely no previous knowledge of radio or science is required. The "Edu-Kit" will provide you with a basic education in Electronics and Radio, worth many times the complete price of \$26.95. The Signal Tracer alone is worth more than the price of the entire Kit.

THE KIT FOR EVERYONE

You do not need the slightest background in radio or science. Whether you are interested in Radio & Electronics because you want an interesting hobby, a well paying business or a job with a future, you will find the "Edu-Kit" a worth-while investment. Many thousands of individuals of all

ages and backgrounds have successfully used the "Edu-Kit" in more than 79 countries of the world. The "Edu-Kit" has been carefully designed, step by step, so that you cannot make a mistake. The "Edu-Kit" allows you to teach yourself at your own rate. No instructor is necessary.

PROGRESSIVE TEACHING METHOD

The Progressive Radio "Edu-Kit" is the foremost educational radio kit in the world, and is universally accepted as the standard in the field of electronics training. The "Edu-Kit" uses the modern educational principle of "Learn by Doing." Therefore you construct, learn schematics, study theory, practice trouble-shooting—all in a closely integrated program designed to provide an easily-learned, thorough and interesting background in radio.

You begin by examining the various parts of the "Edu-Kit." You then learn the function, theory and wiring of these parts. Then you build a simple radio. With this first set you will enjoy listening to regular broadcast stations, learn theory, practice testing and trouble-shooting. Then you build a more advanced radio, learn more advanced theory and techniques. Gradually, in a progressive manner, and at your own rate, you will find yourself constructing more advanced multi-tube radio circuits, and doing work like a professional Radio Technician.

Included in the "Edu-Kit" course are twenty Receiver, Transmitter, Code Oscillator, Signal Tracer, Square Wave Generator and Signal Injector circuits. These are not unprofessional "breadboard" experiments, but genuine radio circuits, constructed by means of professional wiring and soldering on metal chassis, plus the new method of radio construction known as "Printed Circuitry." These circuits operate on your regular AC or DC house current.

THE "EDU-KIT" IS COMPLETE

You will receive all parts and instruction necessary to build 20 different radio and electronics circuits, each guaranteed to operate. Our Kits contain tubes, tube sockets, various coils, hardware, tubing, punched metal chassis, instruction Manuals, hook-up wire, solder, selenium rectifiers, volume controls and switches, etc.

In addition, the Printed Circuit materials, including Printed Circuit chassis, special tube sockets, hardware and instructions. You also receive a useful set of tools, a professional electric soldering iron, and a self-powered Dynamic Radio and Electronics Tester. The "Edu-Kit" also includes Code Instructions and the Progressive Code Oscillator. You will also receive lessons for servicing with the Progressive Signal Tracer and the Progressive Radio-TV Signal and Consultation Service. Certificate of Merit and Discount Privileges. You receive all parts, tools, instructions, etc. Everything is yours to keep.

PRINTED CIRCUITRY

At no increase in price, the "Edu-Kit" now includes Printed Circuitry. You build a Printed Circuit Signal Injector, a unique servicing instrument that can detect many Radio and TV troubles. This revolutionizes the new technique of radio construction is now becoming popular in commercial radio and TV sets.

A Printed Circuit is a special insulated chassis on which has been deposited a conducting material which takes the place of wiring. The various parts are merely plugged in and soldered to terminals.

Printed Circuitry is the basis of modern Automation Electronics. A knowledge of this subject is a necessity today for anyone interested in Electronics.

FREE EXTRAS

- SET OF TOOLS
 - SOLDERING IRON
 - ELECTRONICS TESTER
 - PLIERS-CUTTERS
 - ALIGNMENT TOOL
 - WRENCH SET
 - VALUABLE DISCOUNT CARD
 - CERTIFICATE OF MERIT
 - TESTER INSTRUCTION MANUAL
 - HIGH FIDELITY GUIDE • QUIZZES
 - TELEVISION BOOK • A RADIO
 - TROUBLE-SHOOTING BOOK
 - MEMBERSHIP IN RADIO-TV CLUB
 - CONSULTATION SERVICE • C.C.C.
 - AMATEUR LICENSE TRAINING
 - PRINTED CIRCUITRY

SERVICING LESSONS

You will learn trouble-shooting and servicing in a progressive manner. You will practice repairs on the sets that you construct. You will learn symptoms and causes of trouble in home, portable and car radios. You will learn how to use the professional Signal Tracer, the unique Signal Injector and the dynamic Radio & Electronics Tester. While you are learning in this practical way, you will be able to do many a repair job for your friends and neighbors, and charge fees which will far exceed the price of the "Edu-Kit." Our Consultation Service will help you with any technical problems you may have.

FROM OUR MAIL BAG

J. Stalatis, of 23 Poplar Pl., Waterbury, Conn., writes: "I have repaired several sets for my friends, and made money. The "Edu-Kit" paid for itself. I was ready to spend \$240 for a Course, but I found your ad and sent for your Kit."

Ben Valerio, P. O. Box 21, Magna, Utah: "The Edu-Kits are wonderful. Now I am sending you the questions and also the answers for them. I have been in Radio for the last seven years, but like to build Radio Testing Equipment. I enjoyed every minute I worked with the different kits; the Signal Tracer works fine. Also like to let you know that I feel proud of becoming a member of your Radio-TV Club."

Robert L. Shuff, 1334 Monroe Ave., Huntington, W. Va.: "Thought I would drop you a few lines to say that I received my Edu-Kit, and was really amazed that such a bargain can be had at such a low price. I have already started repairing radios and phonographs. My friends were really surprised to see me get into the wiring of it so quickly. The trouble-shooting Tester that comes with the Kit is really swell... and finds the trouble, if there is any to be found."

UNCONDITIONAL MONEY-BACK GUARANTEE

ORDER DIRECT FROM AD—RECEIVE FREE BONUS
RESISTOR AND CONDENSER KITS WORTH \$7

- Send "Edu-Kit" postpaid. I enclose full payment of \$26.95.
- Send "Edu-Kit" C.O.D. I will pay \$26.95 plus postage.
- Rush me FREE descriptive literature concerning "Edu-Kit."

Name
Address

PROGRESSIVE "EDU-KITS" INC.
1186 Broadway, Dept. 508KK, Hewlett, N. Y.

ANTENNA ANALYZER

plete all wiring except the connection from R2 to SO1 which will be made after calibration.

Calibration. If you plan to use a GDO as a signal source, use the resistor specified for R4. However, if you use your VFO or a link pickup from the transmitter, M1 may be driven off scale. To prevent this, change R4 to 47,000 ohms. If you think you may use either a VFO or a GDO, R4 should be a compromise of about 24,000 ohms.

Set R2 full counterclockwise and connect an ohmmeter across it. Rotate R2 until the ohmmeter indicates 25 ohms, then put the 25-ohm mark on the front panel. Do the same for 50, 75, 100, 150, 200 ohms, etc., up to 500 ohms. Since R2 is linear, in-between points can be easily added. If you are only interested in a limited range of impedances (such as 25 to 100 ohms for CB work), use a 100-ohm pot for R2 (Mallory UA12L, Allied stock No. 28 M 000). Full clockwise rotation will now correspond to 100 rather than 500 ohms.

After calibration connect R2 to SO1 and check the calibration by inserting carbon resistors in SO2. Connect the signal source to SO1. A VFO can be fed directly to SO1. If you use a GDO, connect a one- or two-turn coil to the Analyzer and slip it over the GDO's coil as shown on the first page of this story. Move the loop over the GDO's coil until you get a maximum deflection on M1. Rotate R2 until M1 indicates a null. If the resistor connected to SO2 is 50

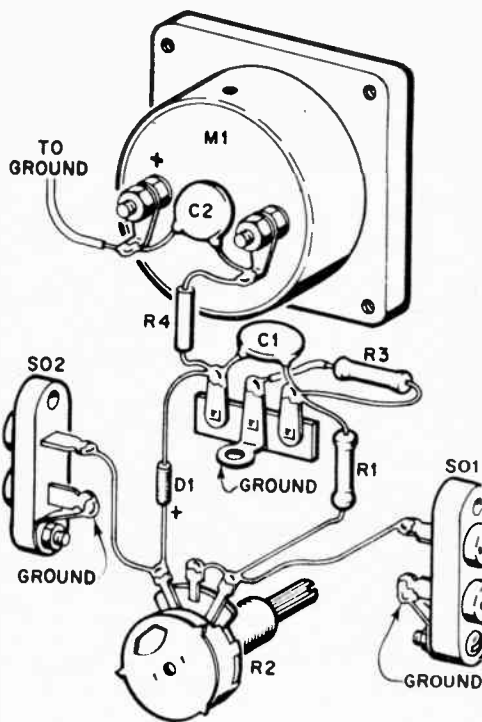

Lead to ground from M1 is soldered to lug under M1's mounting screw. Scrape paint from outside of cabinet under SO1's and SO2's mounting screw.

ohms, R2 should be opposite the 50-ohm mark. If the unit is correctly wired, the null will be at absolute zero or very close to it. If you get only a partial null, the wiring in the Analyzer may be sloppy. If the calibration is consistently off, readjust the knob on R2's shaft or re-mark the dial.

Operation. You'll get greatest accuracy from the Analyzer when it is connected to the antenna through a half-wavelength (or multiple of a half-wavelength) feedline. The half-wavelength line acts as an impedance-matching transformer. If you connect a 50-ohm impedance to one end of the feedline, the other end will appear as 50 ohms.

Here's how you use the Analyzer to determine the exact length of the half-wavelength feedline. Cut the line a little longer than the calculated length. Connect the line to SO2 and feed a signal at your operating frequency to SO1. Set R2 to zero ohms and short the open end of

PARTS LIST

- R1, R3—100-ohm, 1/2-watt, 1% resistor (IRC type DCC, Allied Radio 1 MM 492)
- R2—500-ohm, linear-taper carbon potentiometer (Mallory UA52L and SN1000 nylon shaft. Order Allied Radio 28 M 001 and 28 M 081)
- R4—10,000-ohm, 1/2-watt, 10% resistor (see text)
- C1, C2—.005 mf, 500 V disc capacitor
- D1—1N34A diode
- SO1—Crystal socket (Millen 33102, Allied 72 S 035)
- SO2—Crystal socket (Millen 33102) or SO-239 chassis-type coaxial connector (Allied 40 H 352)
- M1—0-100 micrommeter (see text)
- Misc.—3/8-inch I.D. polystyrene tubing (Allied 43 H 178)

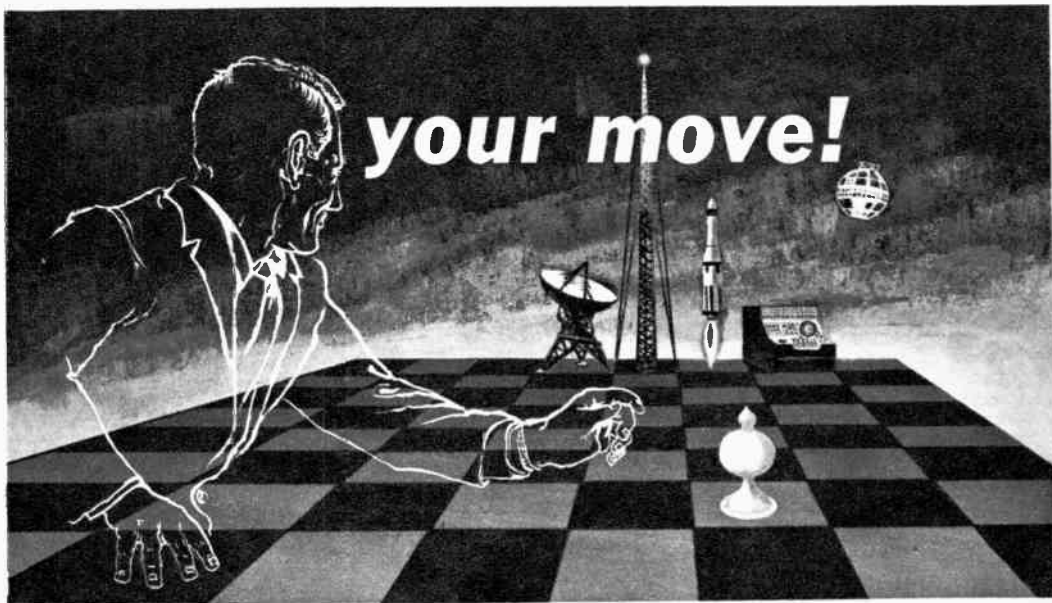

The move into electronics is your decision. **GRANTHAM SCHOOL OF ELECTRONICS** makes your move easier . . .

. . . easier by teaching you electronics in a logical, step-by-step manner, preparing you for employment as an electronics technician or engineer.

Grantham School of Electronics offers training *in the classroom, in the laboratory, and by correspondence*, as explained below.

WHAT Training is Offered

The entire Grantham Electronics training program is divided into a series of *sections or levels*, as follows:

Section IA "begins at the beginning," with the assumption that the student has no previous knowledge of electronics. It prepares him to pass all F.C.C. examination required for a *first class radiotelephone license*.

Section IB is a laboratory training program which gives the student *practical experience* in the operation and maintenance of electronic equipment. Practical lab training is most valuable to the student who understands theoretical concepts upon which it is based. Therefore, Section IB is offered to Grantham students after they have completed Section IA.

Section II begins where Section IB ends, and trains the student in advanced electronics, usually while he is

employed as an electronics technician. Section II prepares the student to advance in both status and income.

WHERE and HOW Training is Offered

Grantham School of Electronics was established in 1951, in Los Angeles, Calif. Since that time, new divisions of the School have been opened at other locations. There are now *five divisions* — located in Los Angeles, South Gate, Seattle, Kansas City, and Washington, D.C.

FCC License Training (Section IA) is offered *in the classroom* at all divisions, and is available *by correspondence* from the Home Study Department of the Kansas City Division. Laboratory Training (Section IB) is offered in Los Angeles and Washington, D.C. Advanced Electronics (Section II) is offered in residence in Los Angeles and Washington, and by correspondence from Kansas City.

Write or Phone for Free Brochure

Your future depends on you. The move into electronics must be your decision. Details of our training (in our 44-page brochure) are free for the asking. Simply mail the coupon below, or telephone one of the numbers listed — *it's your move*.

Prepare for Employment and/or Advancement in Electronics
by training with



GRANTHAM

SCHOOL OF ELECTRONICS



1505 N. Western Ave., Los Angeles, Calif., 90027
9320 Long Beach Blvd., South Gate, Calif., 90280
408 Marion Street, Seattle, Wash., 98104
3123 Gillham Rd., Kansas City, Mo., 64109
821 - 19th Street, NW, Washington, D.C., 20006

HO 7-7727
564-3421
MA 2-7227
JE 1-6320
ST 3-3614

(Mail in envelope or paste on postal card)

To: National Headquarters Office
Grantham School of Electronics
1505 N. Western Ave., Hollywood 27, Calif.

Gentlemen:

Please send me your free booklet describing electronic training. I understand that this does not obligate me in any way.

Name _____ Age _____

Address _____

City _____ State _____

I am interested in: Home Study Classroom Training G-4

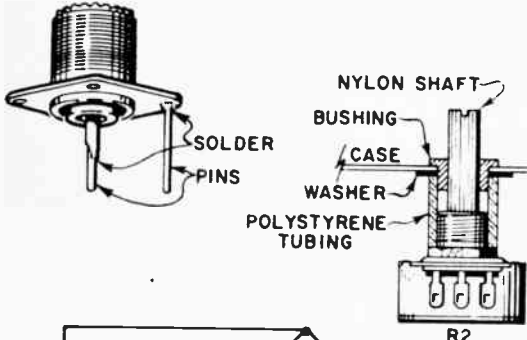

Adaptor (left) should be made if you use both twinlead and coaxial cable. The details of how R2 is mounted are shown in cross section at right.

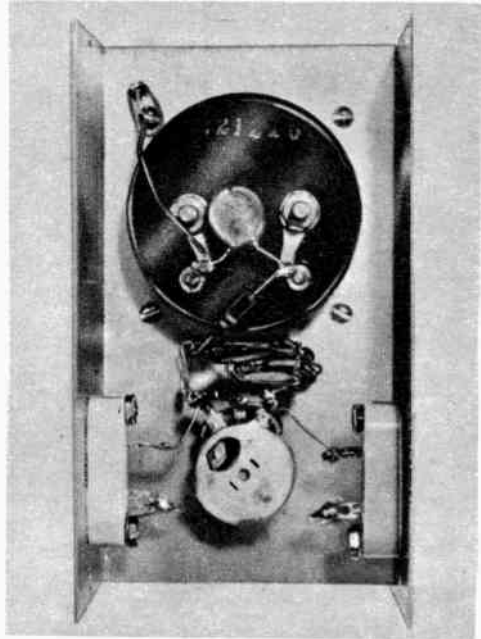

Note parts placement in author's model. When shielding M1 and R2 for 2-meter operation, be careful not to short parts with aluminum foil.

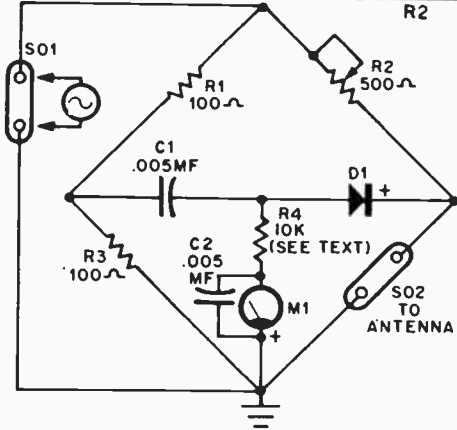

Simple bridge circuit is balanced when antenna-system impedance is same as resistance of R2. Input voltage does not have to be held constant.

the line. M1 will indicate up-scale. Cut off small sections of line then short the line. When the line is exactly a half-wavelength long, M1 will null. (The length of a quarter-wavelength section of line is determined the same way except the free end is not shorted.)

Now for antenna measurements. Connect your antenna to the free end of the half-wavelength feedline and rotate R2 for null. This setting is the antenna's radiation resistance (impedance). A complete null means the antenna is resistive and is precisely tuned to your operating frequency. If the null is not perfect, the antenna is reactive and not resonant at the operating frequency.

SWR can be determined by dividing the antenna impedance by line impedance. If the antenna impedance is 100 ohms and you are using a 50-ohm line, the SWR is 100/50 or 2.

To use the Analyzer to peak-tune an antenna or matching network, connect

the antenna (with a feedline) to S02 and set R2 to the desired impedance. Feed a signal at your operating frequency to S01. When you have adjusted the length of the antenna or its tuning device (gamma-match) and obtained a null, the system will be properly tuned.

Sometimes (as with mobile whips) you do not know what the antenna's resonant impedance should be. To determine it, connect the antenna to the Analyzer with a half-wavelength section, and set the generator to your operating frequency. Adjust the antenna as you turn R2 back and forth (at this time you are not interested in exact impedance) until you obtain a null at some setting of R2. The antenna is precisely tuned at the null. R2 indicates the antenna's radiation resistance. Knowing this you can use the tables in the ARRL Antenna Book to determine the length of transmission line needed for a matched antenna system.

NO DOUBT about it—so many hams are working phone these days that it's impossible to get a *clear* word in edgewise. SSB notwithstanding, CW is the only way out—or should we say in—for more contacts. But going back to code isn't going to be easy for many hams whose fist has grown heavy from holding a mike instead of working a key. And while the hope of going back to CW may be great, the effort required to send code again may seem insurmountable.

EI's Automatic Code Sender is the easiest way for you to recapture the thrills of DX—with less power, on wide-open CW channels and without painfully pounding out each dit and dah. Just press a microswitch button on the sender's typewriter-like keyboard for the character you want and presto!—you'll get a perfectly timed string of crisp dits and dahs.

While automatic code senders aren't new (commercially-made senders can be purchased starting at about \$300) you can build this one for about \$50. With components of the values specified, it will send 16 words per minute—if you can type that fast.

The sender is a project for an experienced builder. A lot of parts and time go into it and you have to watch what you're doing every step along the way. Con-

AND NOW, FOR THE FIRST TIME! AN AUTOMATIC CODE SENDER YOU CAN BUILD

By Morris Grossman

**You type...
It sends code!**

CODE SENDER

struction can't be rushed. We estimate it will take about 20 hours to build. But when you're finished you'll have a shack accessory to be proud of.

Construction. Rome wasn't built in a day and the sender can't be, either. One careless goof along the way may take

hours to find after the job is completed. Take it slow! We have broken construction down to five major steps which should be followed in order:

(1) *The diode matrix*—A large perforated board with 17 vertical columns and 40 horizontal rows to which are connected 80 diodes. The matrix is on the left side of the top of the sender in the photo on the first page of this story. A section of the matrix is on our cover.

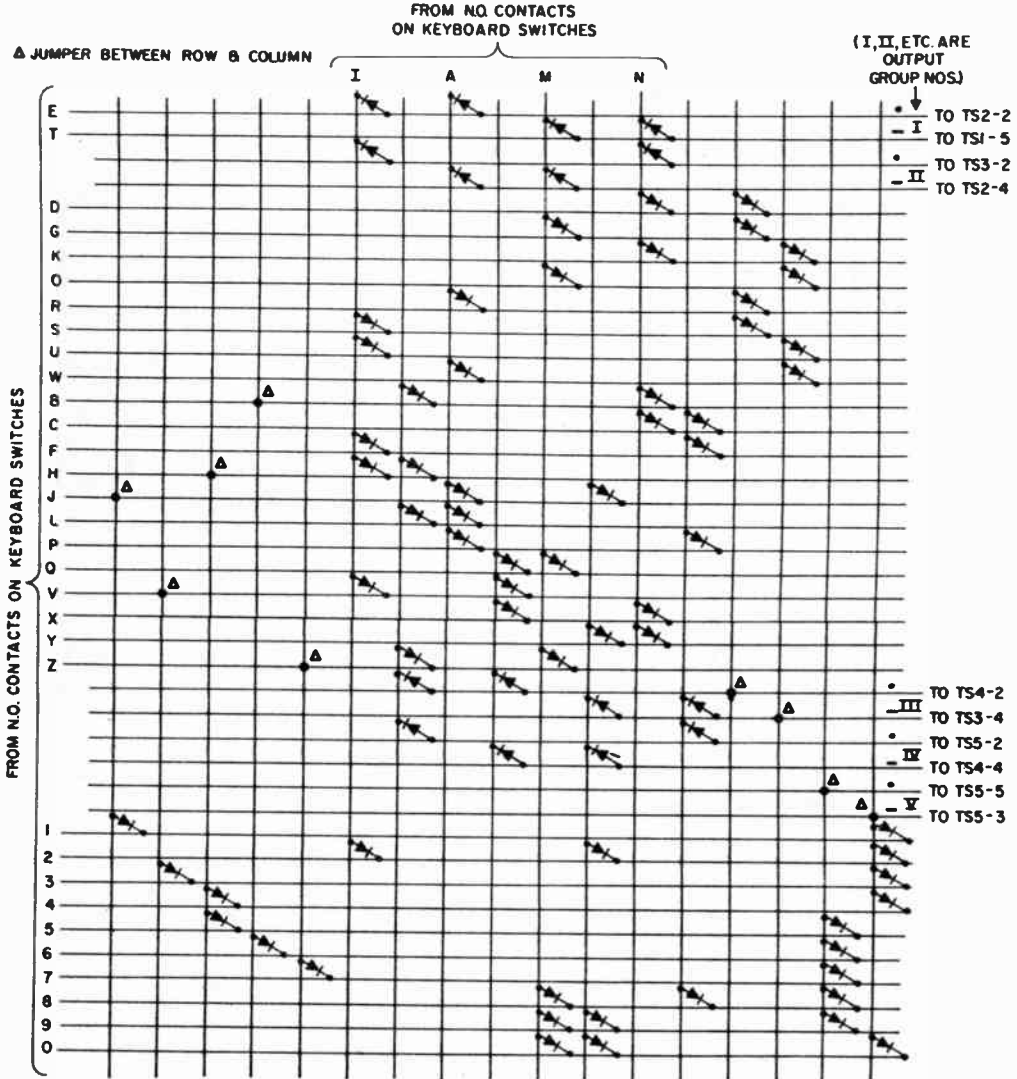

Fig. 1—Diode matrix. Be absolutely sure polarity of all 80 diodes is correct. Start at left column and work from top to bottom and left to right; 9 triangles mean there is a jumper between the row and column.

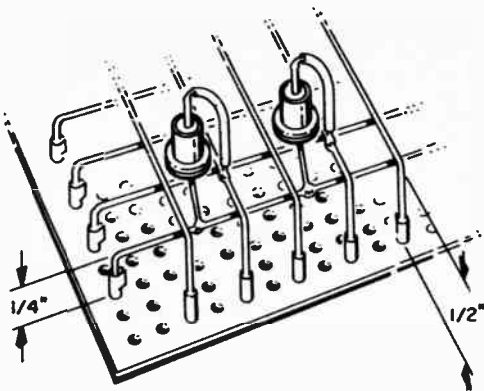

Fig. 2—Closeup of matrix shows diodes' cathode lead connected to column buss wire, spaghetti-covered anode lead connected to row buss wire.

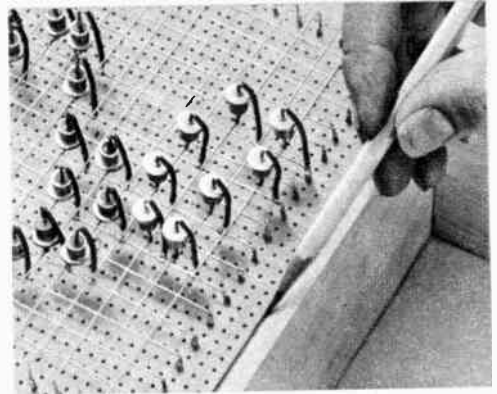

Fig. 3—Portion of completed diode matrix. Note unused rows of holes. Put a few wood screws through perforated board to hold it in frame.

(2) The wood frame and keyboard switches (Figs. 7, 9 and 10).

(3) The relay and components chassis (Fig. 5).

(4) Wiring to and between all relays (Fig. 5 and table, Fig. 12).

(5) Connections to and between the matrix, relay and components chassis and keyboard switches.

• The diode matrix is built on a $16\frac{5}{8} \times 7\frac{5}{16}$ -inch piece of perforated phenolic board. When the board is cut to this size there should be 87 horizontal rows of holes from top to bottom and 38 vertical columns of holes from left to right.

In the third row down from the top and third row up from the bottom, insert a flea clip in *every other* hole, beginning at the second column in from the left. You should end up with 17 flea clips across the top and bottom rows.

In the fifth row down from the top and second column in from the left (and first column in from the right), insert a flea clip in *every other* hole down to and including the fifth row up from the bottom. There should be 40 flea clips in both the left and right columns. The margins at the top, bottom and sides are necessary.

The 17 vertical buss wires are next. They are made of #18 solid wire and are $15\frac{3}{8}$ inches long. Cut seventeen $16\frac{3}{8}$ -inch lengths of wire, roll them flat between two pieces of wood and bend a half inch at each end 90 degrees. Insert the ends of each buss wire in the flea

clips at the top and bottom of the matrix so they're about $\frac{1}{4}$ inch above the board, as in Fig. 2.

The 40 horizontal buss wires are $6\frac{3}{4}$ inches long and are made from $8\frac{1}{4}$ -inch pieces of the same gauge wire. Bend $\frac{3}{4}$ inch at each end 90 degrees. Push the wires in the flea clips on the sides so they're $\frac{1}{2}$ inch above the perforated board, as in Fig. 2. Inspect all the buss wires to make sure they don't touch each other and that they are parallel. Now apply solder to each of the 114 flea clips. Mark each row and column on the left, top and right with the letters and numbers shown on the matrix schematic in Fig. 1.

Before installing the 80 diodes, check each with an ohmmeter set to its lowest

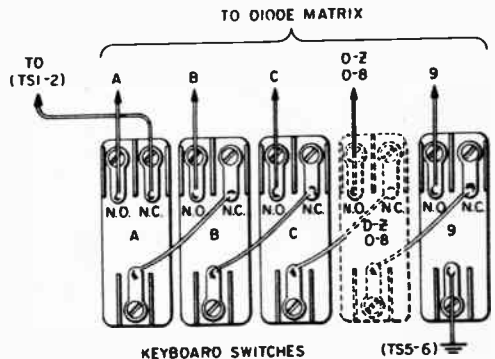

Fig. 4—If switches are arranged like typewriter keyboard, connect lead from N.C. lug to wiper lug on adjacent switch, not alphabetically as here.

CODE SENDER

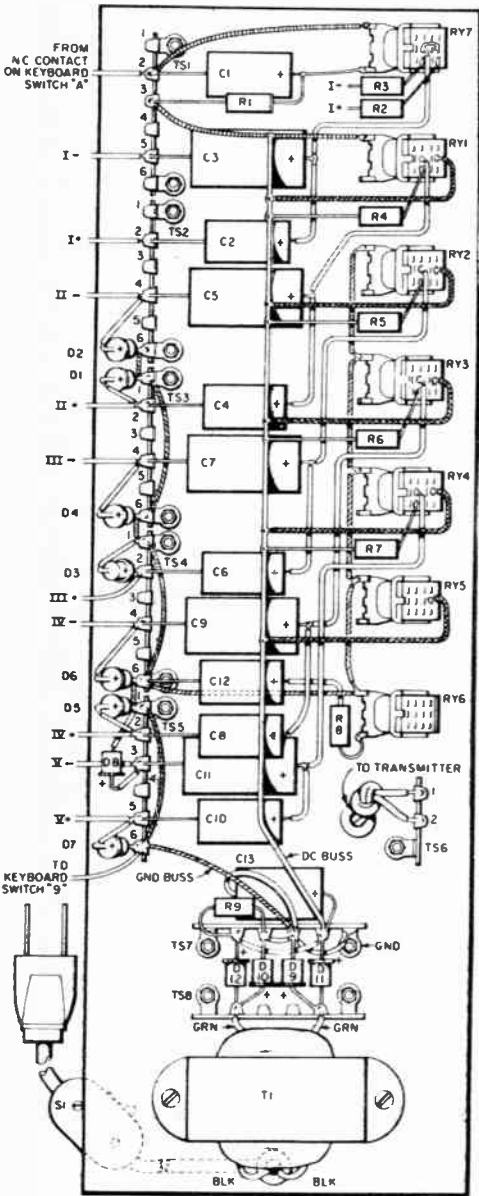

Fig. 5—Relay and components chassis. All relays, capacitors, resistors, the terminal strips and power transformer are mounted on a piece of 16½x3½-inch aluminum. Drill all holes before mounting anything. Drilling holes after the relays are mounted may leave chips in their contacts. After all parts have been installed, make the connections between them as shown. Mark top relay RY7 and number other relays in order from RY1 to RY6. Balance of wiring is covered in Fig. 12.

(R×1) range. Connect the negative lead to the cathode of the diode (see sketch at the right of Fig. 11) and connect the positive lead to the anode. The resistance should be less than 20 ohms. Reverse the leads. The resistance now should be high (over 100,000 ohms). Since diodes are non-linear, you'll measure a different forward resistance on other meter ranges and, for that matter, with different ohmmeters. The forward resistance of 20 ohms, therefore, is only approximate.

If the diode is good, connect it between the vertical and horizontal buss wires, following the schematic in Fig. 1. For example, the diode between the vertical column marked I and the horizontal row marked E has its cathode lead connected to the I buss and the anode lead connected to the E buss. Figure 2 shows exactly what the diode looks like installed. Several places will be crowded so watch for shorts between cases.

After all diodes are installed connect the negative ohmmeter lead to the row marked E at the left of the matrix. Connect the positive lead to the dot line (top) of the group I output at the right of the schematic (marked TS2-2) in Fig. 1. You should measure continuity.

Then connect the positive lead to the dash line in the group I output and to each of the other dot and dash output lines in the four other output groups marked II, III, IV and V. You should get an open-circuit indication on *all other* output lines. Using a chart of the code, go through the alphabet and numbers 0 through 9, checking every letter and number line on the matrix.

Here's how it's done for a five-character number. For the number 2, connect the negative ohmmeter lead to the 2 buss at the left (32nd row down). You should measure continuity on the *dot lines only* in output groups Nos. I and II and the *dash lines only* in output groups III, IV and V.

Where there should be continuity the resistance should be under 75 ohms (again, this will depend on the meter). Where there shouldn't be continuity, the resistance should be more than 100,000 ohms. If there is trouble, go over the connections of all diodes and look for:

(1) open or shorted diodes, (2) diode connected in reverse, (3) diode connected to the wrong buss wire, (4) missing diode or, (5) extra diode.

• **The Frame and Keyboard Switches.**

All dimensions and construction details for the frame appear in Fig. 10. While the paint is drying, solder a short length of wire to the normally closed lug on each of the microswitches before installing them. Refer to Figs. 7 and 9 for installation details.

Turn the frame over and connect the leads soldered to the normally closed lug on one switch to the wiper lug on the adjacent switch, as in Fig. 4. We have shown the hookup between alphabetically arranged switches merely to indicate electrical connectors.

When finished, turn the frame right side up and mount the matrix with the diodes facing up, as in Fig. 3. Connect the wire from the normally open (N.O.) lug on each switch to its corresponding letter or number buss (flea clip) on the left side and top of the matrix. The leads from the normally closed lug on switch A and the wiper lug on switch 9 will be connected later.

• **Relay and Components Chassis.**

Details about mounting relays RY1 through RY7, capacitors, resistors and the power transformer are explained in the caption for Fig. 5. Before installing the relays, inspect their springs to see whether they allow the contacts to make good connections in the energized and de-energized positions. The armature should move freely when depressed with your finger. Closed-contact resistance should be 0.1 ohm. The coil resistance should be about 700 ohms.

• **Wiring To and Between Relays.**

After all wiring to the relays has been completed, using Fig. 5 as a guide, refer to the table of Fig. 12. Start with RY7 and go down the line one lug (numbers at left) at a time both to make sure a connection *has been made* to that lug and to find out what connection must be made *from* that lug to another relay.

For example, under the column for RY7 there should be no connection to or from lug 1. For lug 2 there is the notation 7-8. To save space, we used shorthand and left out only the letters RY. In other

words 7-8 is an abbreviation for RY7-8. Since this is in the box opposite lug No. 2 it means there should be a jumper from lug 8 on RY7 to lug 2 on RY7, the same relay.

Let's try another. Go down the RY2 column to lug 7. Here you see 2-B and 6-12. Again, this is shorthand for RY2-B and RY6-12. This step tells you to connect a wire from lug 7 on RY2 to lug B on RY2 *and* to lug 12 on RY6. The table is set up so you *must* work from left to right, starting with RY7. Don't start in the middle. In some places you'll find the number of parts you installed earlier when wiring from Fig. 5. This is a good check on what you've done.

After all relays have been wired, install the chassis on the right side of the frame and connect the outputs (Group I, II, III, IV, V) on the matrix to terminal strips TS1 through TS5. Connect the wire from the normally closed lug on keyboard switch A (Fig. 4) to lug 2 on terminal strip TS1 and the lead from the wiper contact on keyboard switch 9 to lug 5 on terminal strip TS5. Build the power supply and connect a wire from TS6, lugs 1 and 2 to a plug to match your transmitter's input jack.

Operating Speed. Capacitors C1 through C11 determine the sender's operating speed. By doubling the value of the 20 mf capacitors (with the exception of C1 and C12) to 40 mf and the 60 mf capacitors to 120 mf, the speed will be about eight words per minute. By

PARTS LIST

R1-R8—10-ohm, 1-watt resistor
R9—5,000-ohm, 1-watt resistor
C1, C2, C4, C6, C8, C10, C12—20 mf, 50 V electrolytic capacitor (Lafayette C-100 or equiv.)
C3, C5, C7, C9, C11—40 mf, 50 V electrolytic capacitor
C13—100 mf, 50 V electrolytic capacitor
D1-D12 and 80 matrix diodes—750 ma, 100 PIV silicon top-hat diodes. Available for 9¢ each plus postage from Warren Electronics Co., 87 Chambers St., New York, N. Y. 10007.
S1—SPST feed-thru switch
T1—Power transformer: primary 117 VAC; secondary 25 V @ 1 A (Allied Radio 61 G 421 or equiv.)
RY1-RY7—APDT relay, 24-volt DC, 700-ohm coil. Allied Control Co. # TAT-4C. Available for \$3.21 each plus postage from Newark Electronics Corp., 223 West Madison St., Chicago, Ill. Catalog No. 59F481.
Keyboard switches—SPDT microswitches. Available at 5 for \$1 plus postage from Herbach and Rademan, Inc., 1204 Arch St., Philadelphia, Pa. 19107. Catalog No. TM-7059.
Misc.—130 flea clips (Lafayette MS-263), 18x7-5/16-inch perforated board (Lafayette MS-916), #18 buss wire (Belden 8019 or equiv.), terminal strips.

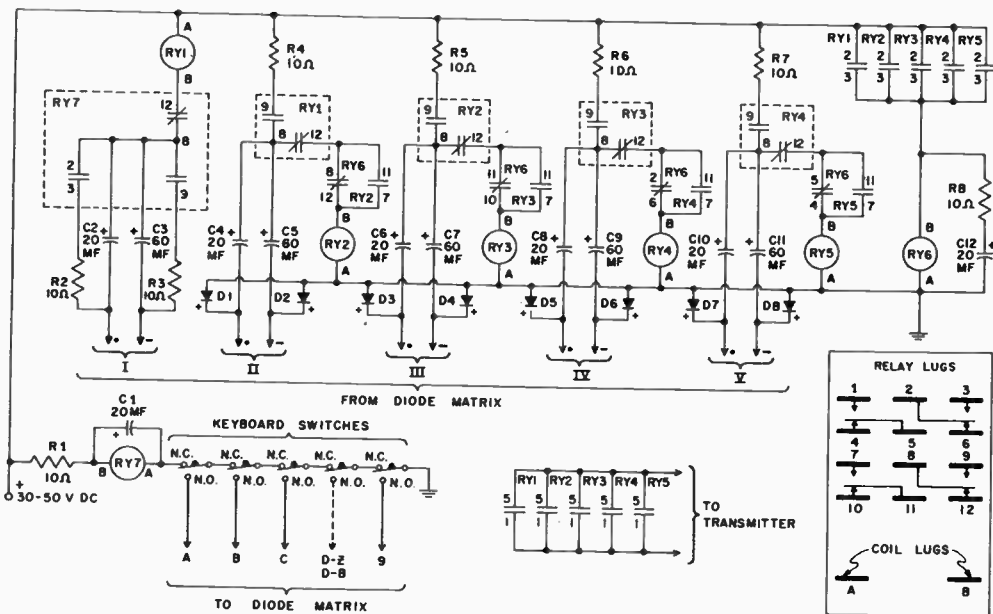

CODE SENDER

Fig. 8—Schematic of sender. Because of complex relay wiring, we used industrial symbols. Fig. 11 shows how these symbols are related to the type normally used in EI schematics. Use this schematic as a final check on all wiring.

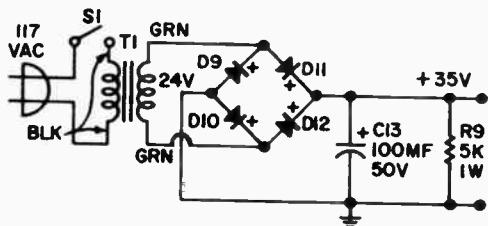

Fig. 6—Power supply. Full-wave bridge rectifier will provide a stable 35-volt output for sender.

Fig. 9—Notice how the microswitches are stacked one row above the other and offset slightly so keyboard will resemble that of a typewriter.

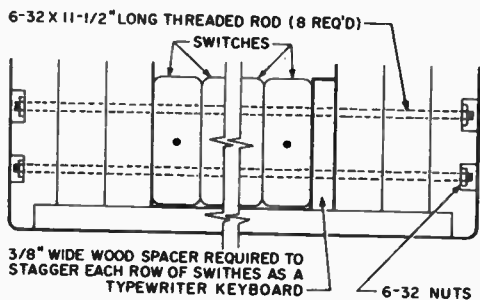
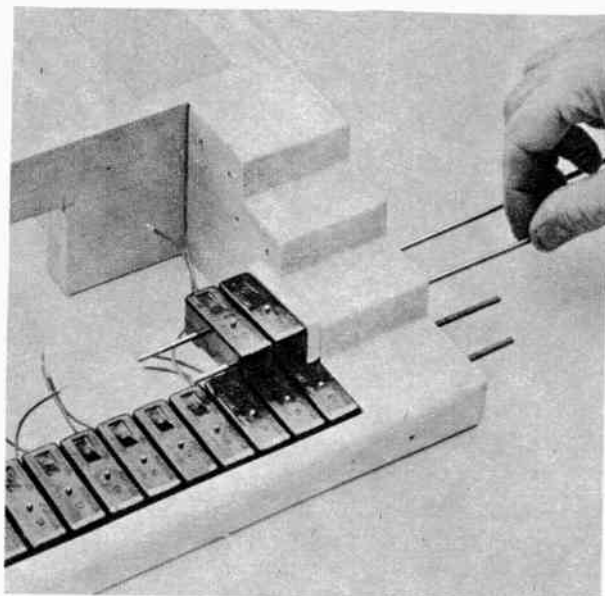

Fig. 7—Cutaway view of keyboard shows how the microswitches are mounted and are held in place.



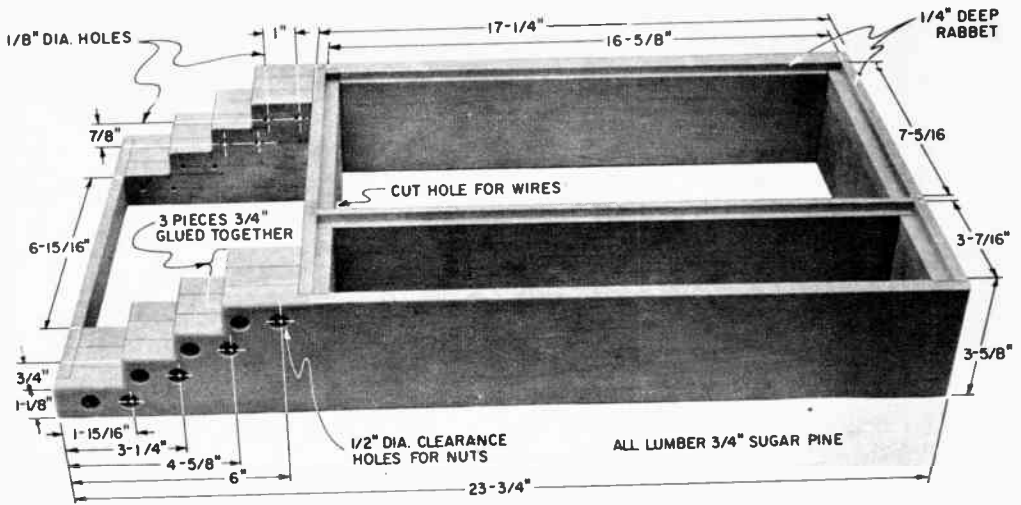

Fig. 10—Frame for the sander is built entirely of $\frac{3}{4}$ -inch-thick sugar pine. Check switches before installing. It will be a big job to remove one of the dowels from the $\frac{1}{2}$ -inch-diameter nut-clearance holes if switch has to be taken out. Matrix and relay chassis can be covered with 12x17x3-inch chassis.

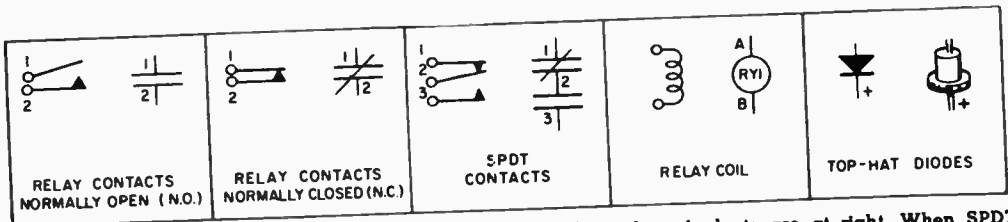

Fig. 11—Our normal relay symbols are shown at left. Industrial equivalents are at right. When SPDT relay armature transfers, think of diagonal line moving from contacts 1 and 2 to contacts 2 and 3.

		RELAY NOS.						
		RY7	RY1	RY2	RY3	RY4	RY5	RY6
LUG NOS.	1	-	2-1	3-1	4-1	5-1	TS6-1	-
	2	7-8	B+	B+	B+	B+	B+	-
	3	R2	2-3	3-3	4-3	5-3	6-8	-
	4	-	-	-	-	-	-	-
	5	-	2-5	3-5	4-5	5-4	TS6-2	-
	6	-	-	-	-	-	-	-
	7	-	-	2-8,6-12	3-8,6-10	4-8,6-6	5-8,6-4	-
	8	C2, C3	C4, C5	C6, C7	C8, C9	C10, C11	-	-
	9	R3	R4	R5	R6	R7	-	-
	10	-	-	-	-	-	-	-
	11	-	-	-	-	-	-	-
	12	1-B	2-11,6-8	3-11,6-11	4-11,6-2	5-11,6-5	-	-
A	TS1-2	B+	GND	GND	GND	GND	GND	
B	R1, C1	7-12	2-7	3-7	4-7	5-7	R8, 5-3	

Fig. 12—Connections to and between relays. Empty boxes (especially RY6) don't mean there are no wires on lugs. Connections may have been made before and when working right from RY7.

halving the value of the capacitors to 10 and 30 mf, the speed will be about 25 words per minute. Always keep a 3-to-1 relationship.

The capacitance of electrolytics, especially cheap ones, often is different from what's printed on the label. A variation of ± 20 per cent won't matter. But if the dashes sound like dots, connect a small-value capacitor in parallel with C3, C5, C7, C9 or C11, depending on which dash in a string of five is too short. Capacitors C2, C4, C6, C8 and C10 determine the length of the dots. C2 and C3 are the first dot or dash in a string of five.

The sender's speed also is affected by the power-supply voltage. Increasing the voltage to 50 volts will reduce the speed approximately 20 per cent.

The B A T T E R Y A N A L Y S T

At a glance you get a battery's terminal voltage and current drain under simulated load.

By Bert Mann

IT'S always a surprise to test dead flashlight batteries and find they check out at 1.5 volts—the same voltage as that of fresh replacements! Unusual? Not when you consider that it's also common to measure 9 volts across the terminals of a transistor-radio battery, even though the radio won't play. Until a battery is destroyed by chemical decomposition, it's always possible for it to give a reading at its rated voltage.

The explanation is simple. Any battery's voltage will measure normal without a load. But when called upon to deliver current when you connect a load, a *defective* battery's voltage drops.

To test a battery meaningfully, the terminal voltage *must* be measured with a load. EI's Battery Analyst simulates actual operating conditions by loading a battery to produce up to a 300 ma current drain.

The tester has two parts. The first, the load section, controls and indicates (in ma) the current drawn from the battery. You can test a D-size battery with as little as a 3-ma drain (to simulate the drain of a code-practice oscillator) or a 200-ma drain (to simulate a flashlight). There are five full-scale ranges of 3, 9, 30, 90 and 300 ma.

The second section is a voltmeter with full-scale ranges, chosen so common batteries will produce from one-half to full-scale deflection—the most accurate part of a meter scale.



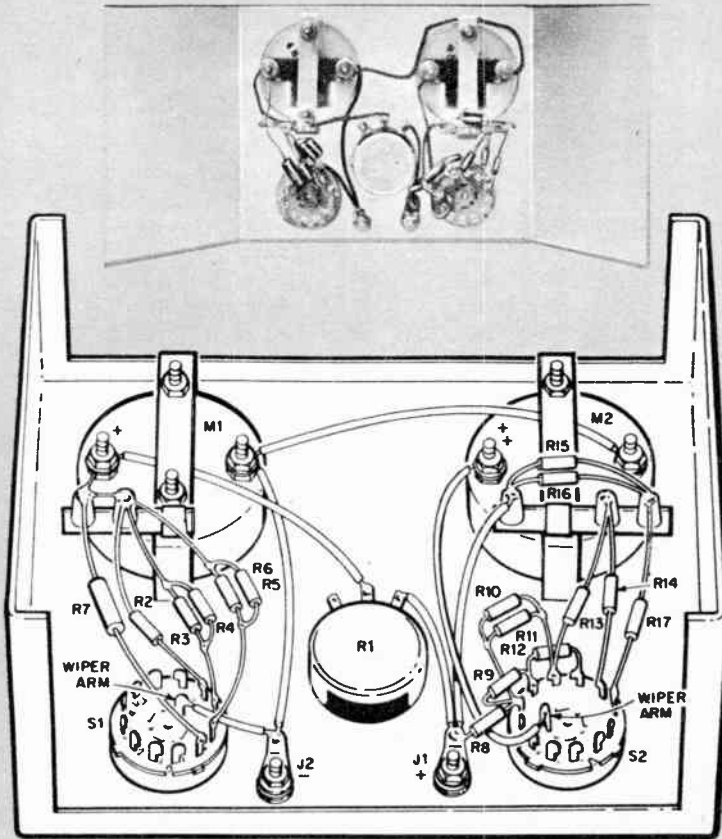

Cabinet may be made of wood, plastic or metal so long as front panel is at least 5x6 inches. Wiring is not critical. Take care not to damage plastic meter cases with soldering iron. The range switches, S1 and S2, have 12 positions. The unused terminals can be hooked up for extra voltage or current ranges if necessary.

PARTS LIST

Resistors: 1/2 watt, 5% unless otherwise indicated
 R1—10,000-ohm wirewound potentiometer (see text)
 R2—270 ohms R3, R4—110 ohms
 R5—33 ohms
 R6—36 ohms

R7—5.1 ohms, 1 watt
 R8, R13—1,000 ohms
 R9—3,000 ohms
 R10, R11, R15, R16—16,000 ohms
 R12—10,000 ohms
 R14—39,000 ohms
 R17—91,000 ohms

M1—0-3 ma Shurite type 850 meter (Lafayette MT-129)
 M2—0-1 ma Shurite type 850 meter (Lafayette MT-128)
 S1, S2—Single-pole, 12-position rotary switch (Mallory 31112J)
 J1, J2—Five-way binding posts

To keep the cost down (about \$15) yet provide good accuracy, we used low-cost meters and 5 per cent multiplier resistors. For greater accuracy eliminate the voltmeter section (M2, S2 and resistors R8-R17) and use your own VOM or VTVM.

Construction. Resistors R2-R7 were chosen to provide ranges of 3, 9, 30, 90 and 300 ma with the 0-3 ma meter specified. Do not substitute a different meter or the calibration will be incorrect. Since M1's dial has markings at 1, 2 and 3 ma, add transfer-type numbers 3, 6 and

9 above 1, 2 and 3, respectively, for the other ranges.

R1, a 10,000-ohm potentiometer, will handle batteries up to 90 volts. However, it must be adjusted carefully when testing low-voltage batteries at low current (a 1.5-volt battery at 10 ma). If you don't plan to test batteries larger than 22½ volts, change R1 to 5,000 ohms to make low-current adjustments easier.

The voltmeter section uses a 0-1 ma, 1,000-ohms-per-volt meter whose scale can be used for the 10- and 100-volt ranges. Again, apply transfer numbers

The BATTERY ANALYST

on the scale for the 2-, 5- and 50-voltage ranges. It's helpful to add a .8-volt designation (for the two-volt range) above the .4-ma point on the scale. This will be the reject voltage for 1.5-volt batteries.

The value of the multiplier resistor (resistor in series with M2) for additional voltage ranges is equal to the desired voltage range times 1,000 minus 1,000. For example, a 20-volt range would require a 19,000-ohm resistor $[(20 \times 1,000) - 1,000]$. A 40-volt range would require a 39,000-ohm resistor $[(40 \times 1,000) - 1,000]$.

Using the Analyst. Set S2 to the voltage range just above that of the battery to be tested. Set S1 to the highest current range (300 ma) and turn R1 fully counter-clockwise. Connect test leads to the battery and adjust R1 for the desired load current. (See the table below for current ranges.)

Consider the battery good if the voltage is 80 to 100 per cent of its nominal rating. A 1.5-volt battery would be good if its voltage under load is 1.2 volts or higher. A battery is *usable* if the voltage is 55 to 80 per cent of its nominal rating (.825 volts or higher for a 1.5-volt battery). If the voltage is below 55 per cent, discard the battery.

Note that transistor-equipment batteries are tested at lower current. For example the run-of-the-mill D-cell is

Battery Test Currents			
Voltage	Test Current (ma)	Voltage	Test Current (ma)
1.5 (D)	270	9.0	100
1.5 (D)*	50	9.0*	9
1.5 (C)all	50	13.5	9
1.5 (AA)all	50	22.5	30
4.5	100	22.5*	2
4.5*	50	45	9
6.0	50	90	15

*Electronic Applications Type

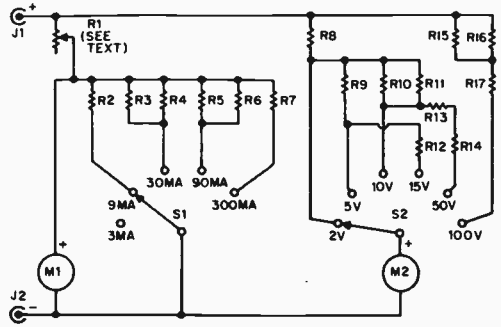

Load section of analyst consists of M1, S1, R1 and shunt resistors R2 to R7. Voltmeter section includes M2, S2 and multiplier resistors R8 to R17.

checked at 270 ma while the electronic applications D-cell, such as is used in transistor radios, is checked at 50 ma. As a general rule, batteries used in transistor equipment or to supply the B+ voltage in tube equipment, are checked at the transistor values.

Just because a full-current test rejects a battery, this does not necessarily mean it always has to be discarded. The battery that checks bad with a 200-ma drain still can provide service for many months if used in experimental projects in which the current drain is low. A crystal calibrator or code-practice oscillator are examples of devices which the author powers with "dead" batteries.

Internal Resistance

And talking about dead batteries this is how they "die." Because the material of which batteries is made is not a perfect electrical conductor, all batteries have what's called internal resistance. A way to understand this is to think of a battery as a combination of a source of voltage in series with a resistor.

The internal resistance of a new battery is very low as long as the recommended current drain is not exceeded. As the battery is used, the internal resistance increases. The result is that the voltage drop across the internal resistance (that theoretically built-in series resistor) becomes so great that the battery's terminal voltage falls to a level too low to supply current to the load. Looking at it another way, the increased internal resistance limits the current the battery can supply to a circuit in which it is a series element.



Low-Cost DIRECTION FINDER

By Len Buckwalter, KBA4480

The S-meter on your transceiver will indicate a null when the flat side of the loop antenna and the pointer are aimed directly at the source of a distant CB transmission.

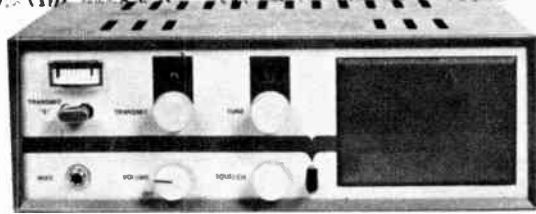

A distressed mariner many miles from shore or in the middle of a pea soup fog blesses the CB rig on his boat when he calls for assistance. But a CB operator on land or another boat may not be able to offer much help since he can't always tell readily or exactly which direction the signal is coming from. For you to be of real assistance to water-borne CBers, a directional loop antenna is a must.

Designed for mobile use, our direction finder will zero in on a signal with pin-point accuracy. The Finder can also be used to locate a transmitter

that's been causing disturbing TVI

Construction. Start by building the one-transistor RF amplifier on a piece of $1\frac{1}{8}$ x 5-inch perforated board, positioning the parts exactly as shown in the pictorial and photo. Before mounting trimmer capacitors C2 and C5, bend their connecting lugs upward and enlarge three adjacent holes in the perforated board for the mounting tabs and adjusting screw. C2 and C5 are held in place by bending their tabs flat underneath the board.

L2 and L3 are wound on 1-watt resistors rated at 1 megohm or higher

DIRECTION FINDER

Start with L2 by scraping clean the end of a length of No. 24 enameled wire and soldering it to the resistor lead. Wind five turns, bring out a half-inch loop and twist it. Wind 18 more turns, scrape the enamel from the end of the wire and solder it to the other resistor lead. The loop is the point to which C3 and the center lead of the coax from the loop (pickup coax) are to be soldered.

L3 has the same number of turns (23) as L2 but it has no loop. After L3 is installed, scrape the enamel from a spot on the fifth and sixth turns (from the ground end) and solder to this point the center lead of the coax that goes to the CB transceiver (feed coax). Q1's leads are soldered directly into the circuit, so take care not to apply too much heat to them. Cut short the lead between Q1's base (B) lead and collector (C) lead. Now install all other components.

The Finder's handle is a one-foot length of 1 1/4 OD aluminum TV antenna mast. Cut a notch for S1 at the bottom as shown in the pictorial and mount a cable clamp for the feed coax. Remove 3 inches of insulation from the feed coax so its shield will make good contact with the lug on the circuit board and handle cable clamp. For the loop, cut two slots 5/8-inch deep by 1/2-inch wide opposite each other in the top of the handle. For the pickup coax, cut a deeper slot.

Make the 9-inch-diameter loop from a 30-inch length of 3/8-inch OD copper tubing (you can get this at a plumber's supply house). Remove a 1-inch section in the top, insert C1's mounting lugs in the open ends, crimp the ends of the tubing and apply solder. Position the loop in the notches in the top and drill a #6 hole through the handle and loop for a 1 1/2-inch long #6 machine screw. Remove the loop and solder the shield of the 11-inch pickup coax to the bottom of it. Then, solder the center coax lead

Heavy wire at left of board is ground buss. Run it through top of C2, wrap it around battery and solder it to case. Shields of both pieces of coax also must be soldered to this ground buss.

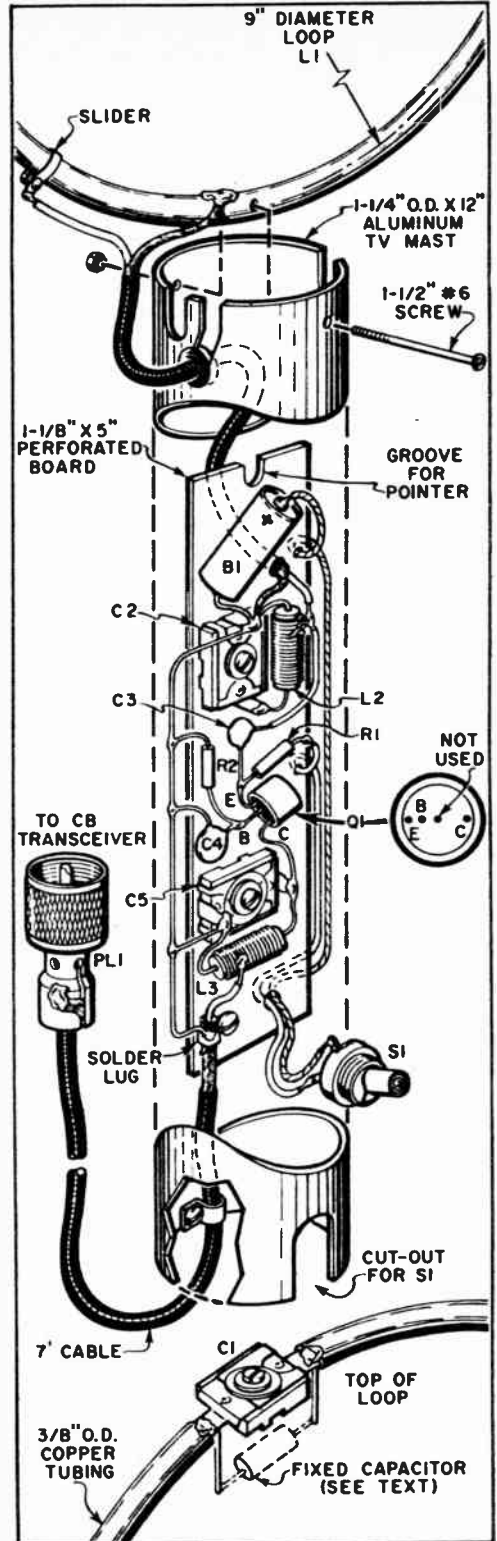

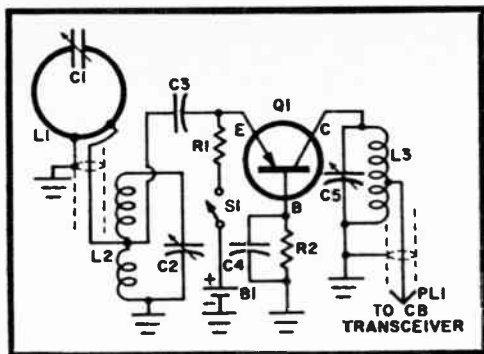

When flat surface of L1 (tuned by C1) faces station, signal is equal at its sides and S-meter nulls. Q1 amplifies the signal when L1 is turned.

(3½ inches long) to a home-brew slider. Now connect the shield on other end of the pickup coax to ground (junction of C2 and L2) and the center lead to the tap on L2.

Insert the feed coax first, sliding the entire assembly into the handle (it does not matter if the pickup coax shield on the loop touches the handle) and then mount the loop. Insert the pointer and fasten the feed-coax shield to the bottom of the handle with a cable clamp.

Tune-Up. Connect the feed coax to a CB transceiver that has an S-meter. Having connected a dummy load (#47 pilot lamp) to the output of another CB transceiver (tuned to the same channel) to reduce its output power, set this transceiver to transmit. Move a distance away and adjust C1, C2 and C5 with a nonmetallic alignment tool for a peak indication on the S-meter. Move the slider up and down on the loop to further peak the S-meter. There will be interaction between these adjustments so repeat them several times.

One or more adjustments may not produce peak indication. That is, tightening the screw on C1 all the way may make the meter needle rise but not fall. If this happens, solder a 10 or 20 mmf capacitor in parallel with C1. You should now be able to make the S-meter needle rise and fall by adjusting C1. If C2 or C5 doesn't produce a peak indication, try adding 10 or 20 mmf capacitors in parallel with them as described above. If this doesn't work, rewind L2 or L3, adding a few turns at the top.

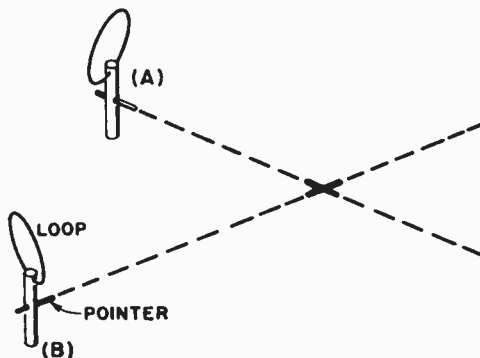

To find correct null, locate yourself on map at A, find null and draw line parallel to pointer. Drive to B and repeat. Signal's at intersection.

Except for the slider, tune the loop with C1 when you change channels and prior to each use. Another check on circuit performance can be made by connecting a milliammeter across S1 with the power turned off. You should get a reading of 1 to 2 ma.

Do not use the direction finder within close range of a 5-watt transmitter or it may be overloaded and Q1 will be damaged. In strong signal areas, there will be enough leakage through Q1 for the direction finder to work with the power off. And never use the direction finder for transmitting.

Using the Finder. Aim the flat surface of the loop in the general direction of a signal and rotate it for a null S-meter indication. In this orientation the wood pointer indicates a line along which the station lies. Since you'd also get a null with the loop rotated 180 degrees, you'll have to pull out a road map, a compass and take two fixes as shown in the diagram at the top of this page. The transmitter is where the lines cross.

PARTS LIST

- R1—470-ohm, ½-watt resistor
- R2—33,000-ohm, ½-watt resistor
- C1, C2, C5—3-30 mmf trimmer capacitor (Allied 13 L 511 or equiv.)
- C3—100 mmf, 50 V or higher ceramic disc capacitor
- C4—81 mf, 50 V or higher ceramic disc capacitor
- Q1—2N1178 transistor (RCA)
- B1—½-volt battery (Burgess NE or equiv.)
- L1—9-inch diameter loop (see text)
- L2, L3—23 turns No. 24 enameled wire (see text)
- S1—SPST switch
- PL1—Plug to match antenna jack on CB rig
- Misc.—Perforated phenolic board, solder lugs, cable clamp, 8 feet RG58/U coax.

CB SIGNAL BOOSTER

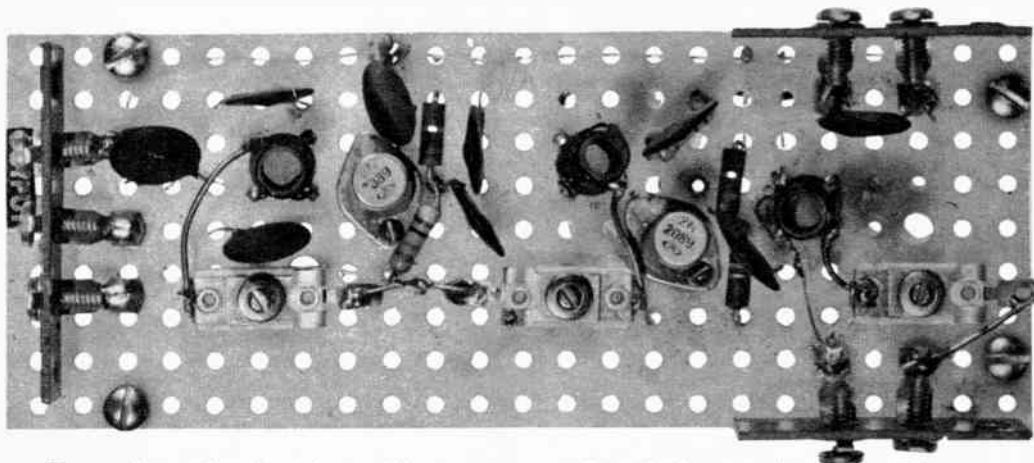

Transistorized unit achieves up to 24 db boost in reception.

By Kevin Redmond, K2HTZ

YOU can add greater sensitivity, lower cross-modulation, and quieter operation to your rig with the twenty-four db of gain provided by this versatile CB Signal Booster. Low sensitivity receivers use its high gain to improve sensitivity while high sensitivity receivers can use the gain to permit higher squelch settings and therefore quieter reception. Output impedance taps on the booster allow matching to a variety of antennas and receiver input stages. Satisfactory performance is delivered with a DC supply range of six to twelve volts assuring adaptability to various supply systems.

Construction has been simplified by mounting all parts on a perforated board. When completed, the board can be used as a subchassis mounted inside a CB rig or in a Minibox using stand-offs as mounting supports. The three coils are closewound on paper coil forms with the taps at the end of the coil nearest the mounting. Be careful not to bend the lugs too much when mounting the coil as the form may separate from its mounting base. The layout shown in the pictorial should be followed closely, except that the socket of transistor Q1 should actually be installed between L1 and L2 for the shortest possible leads. It's important that the "ground side" of trimmer capacitors C1, C2 and C3 be connected to the bottom end (D) of coils L1, L2 and L3. See photo. If this is not done hand capacitance effects will make tuning difficult.

Coupling capacitors C4 and C5 carry RF and must be kept away from ground leads and RF circuitry or coupling from the capacitor body will reduce gain or cause oscillation.

DC Check. Once the unit has been completed, check the DC operating point first. This can be done by measuring the DC

Photo of author's prototype of Booster differs slightly from pictorial below. Most wires are run on reverse side of perforated board and transistor Q1 is located between L1 and L2. The photo should be followed, particularly in the placement of trimmers C1, C2 and C3.

in the pictorial below, for the sake of clarity the component and other interconnecting leads are shown longer than required. In this unit, as in all RF devices, leads should be short and run direct as possible. The taps on the coils should be connected to the lettered lugs.

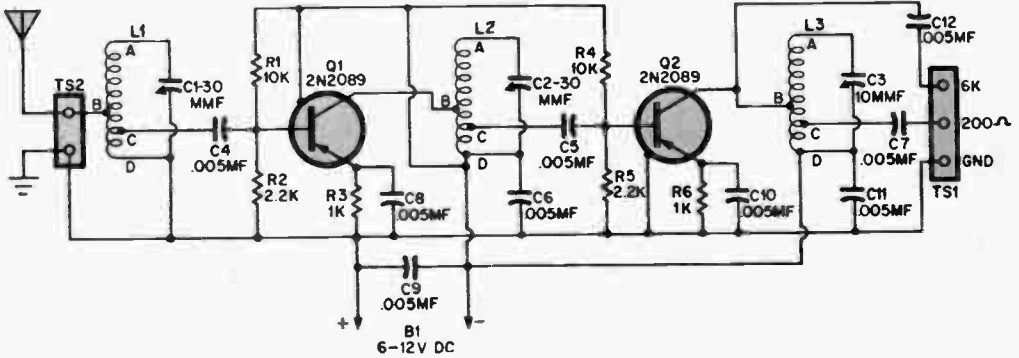

R1, R4—10,000 ohms resistor, 1/2 watt, 10%
 R2, R5—2,200 ohms resistor, 1/2 watt, 10%
 R3, R6—1,000 ohms resistor, 1/2 watt, 10%
 C1, C2, C3—2-30 mmf trimmer capacitor
 C4 to C12—.005 mf low-voltage ceramic discs or .0047 mf tubular types

PARTS LIST

Q1, Q2—2N2089 transistor (Amperex)
 L1—.285" dia. Cambion coil form, SPC-2J4L, slug removed; 26 turns closewound #28 enam. wire tapped at 1 and 6 turns
 L2, L3—Same form as L1; 26 turns

tapped at 1 and 5 turns
 TS1—3-screw terminal strip
 TS2—2-screw terminal strip
 Misc. — Perforated board (approx. 8 1/2"x2 1/2"); flea clips; plastic cabinet two 4-lead transistor sockets, hardware, etc.

A kit of the above parts (except battery, switch and cabinet) is available from PR Laboratories, South Hillside Ave., Nesconset, N. Y. \$9 postpaid.

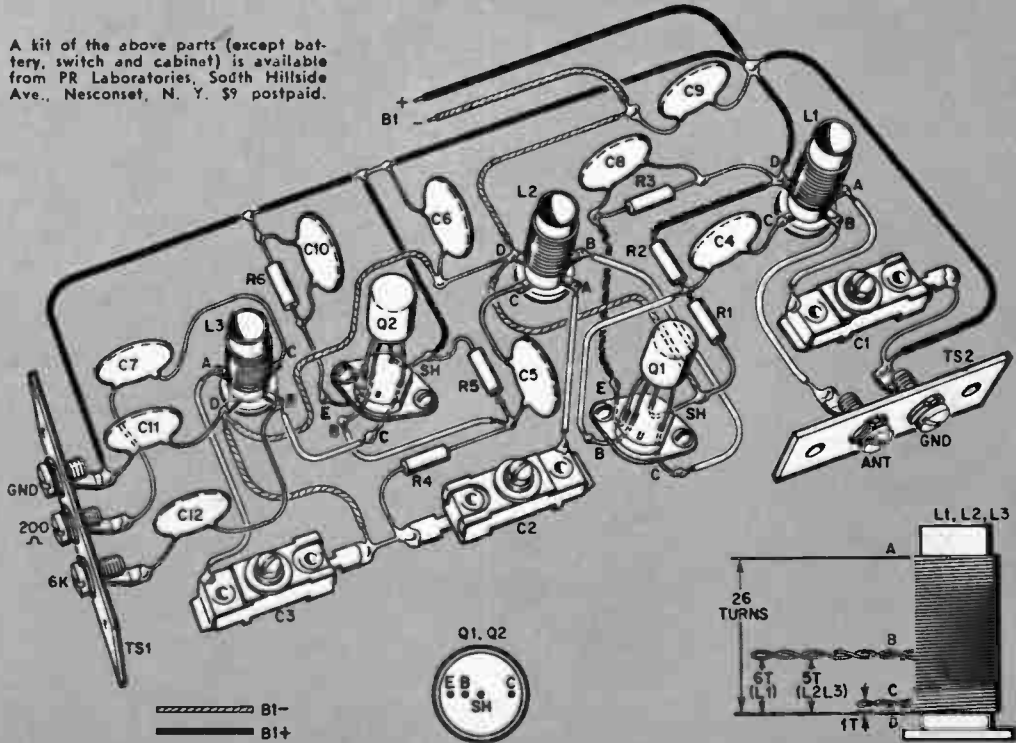

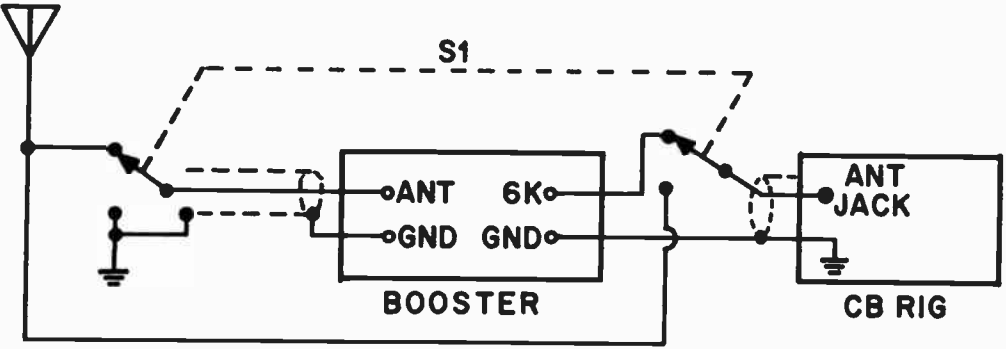

To protect the Booster during transmission periods, a double-pole, double-throw slide switch is required in addition to the transceiver's normal P-T switch. See text for specific details.

voltage across R3 and R6. At a supply voltage of 6 volts, the voltage across each of these resistors should be approximately 1 volt. Or, with a supply voltage of 12 volts, the reading will be about 2 volts. The voltages across R2 and R5 should be .25 volts higher than those across R3 and R6.

Tuning the Booster. To adjust the tuning capacitors (C1, C2, C3) connect the Booster's 6K output and Gnd terminals to a short length of coax cable fitted with a plug to match the antenna input jack of the CB receiver. The receiver should be tuned to a center band channel. A transmitter on the same channel can be used as the signal source if it is kept at least 10 feet away from the Booster. No antenna should be used for the booster at this step. Capacitors C1, C2 and C3 should be now adjusted for maximum signal as determined audibly or read by the receiver's S-meter.

If a signal generator is used as the signal source, an 18,000 ohm resistor should be used between the generator's hot lead and antenna terminal of the Booster. In addition, a 12 mmf capacitor should be installed across the antenna and ground terminal of TS2.

Using the Booster. With transceivers, special precautions must be taken not to damage the booster's transistors when transmitting. The simplest solution is to connect a DPDT switch as shown in the diagram. This switching arrangement will work with practically

all receiving systems. The booster input is shorted during transmission when the DPDT switch is thrown to the *xmit* position. Use a DPDT slide switch or other low capacitance type as both the RF input and output of the booster go through it. S1 is shown set for *receive*.

Standard antennas, including whips, are connected to TS2. An antenna with a loading coil or one which reflects a low impedance because of mismatch or overlong transmission line is connected directly to tap C on L1. Either connection is made via the slide switch mentioned above.

If your rig is transistorized, the 200-ohm output terminal on the Booster can connect directly to the base of the RF input transistor. As an alternative on a handi-talkie type rig, the 6K output of the Booster can be connected directly to the whip antenna. Gnd on the Booster connects to the ground of the CB unit. Super-regen receivers will probably only be able to operate with the direct antenna connection.

There are several inexpensive handi-talkies which use the super-regen receiver stage as their transmitter. Don't expect the Booster to be of much help.

When receiving strong stations, the Booster may provide excessive amplification and cause blocking in the CB rig's input stage. This problem is easily solved by reducing antenna length or by dropping the voltage feeding the Booster.

The COM-VOX

Amateurs or CBers can have automatic T-R switching with this voice-operated relay.

RELAX, fold your hands in your lap and let the Com-Vox switch your rig automatically from transmit to receive and back again. You're enjoying the ultimate in communications luxury with a gadget that takes the work out of the ham or Citizens Band shack.

When people hear the term VOX (voice-operated transmit/receive switching) they usually think of high-priced, single-sideband equipment and immediately count themselves out. But EI's Com-Vox, which can be added to any transmitter designed for push-to-talk operation, puts the pauper into the prince's class.

Here are some of the Com-Vox's features: Its sensitivity is adjustable. It has a time delay which can be set to turn the transmitter off between words, or keep it on up to 10 seconds after you stop speaking. And if your transmitter is shy on modulation, the Com-Vox can be used as a mike preamp. Best of all, the Com-Vox has an anti-trip circuit that really works. This means that you can raise the volume of your receiver's speaker till your ears hurt, but the Com-Vox will not operate until you speak into the mike.

Construction. Our Com-Vox is built on a 7x5x2-inch chassis. Shielded sockets must be used for V1, V2 and V3. Since space is at a premium, use ceramic disc capacitors. In order to keep down the physical size of C7 and C8, you may use 50- or 75-volt capacitors.

Since your mike's output is fed to both the Com-Vox and the transmitter, J1 is connected directly to J2 with shielded cable—only one end of which is grounded. If your transmitter requires a higher-level input signal to produce full modulation, connect J2 to

By Herb Friedman, W2ZLF



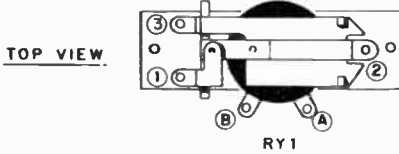
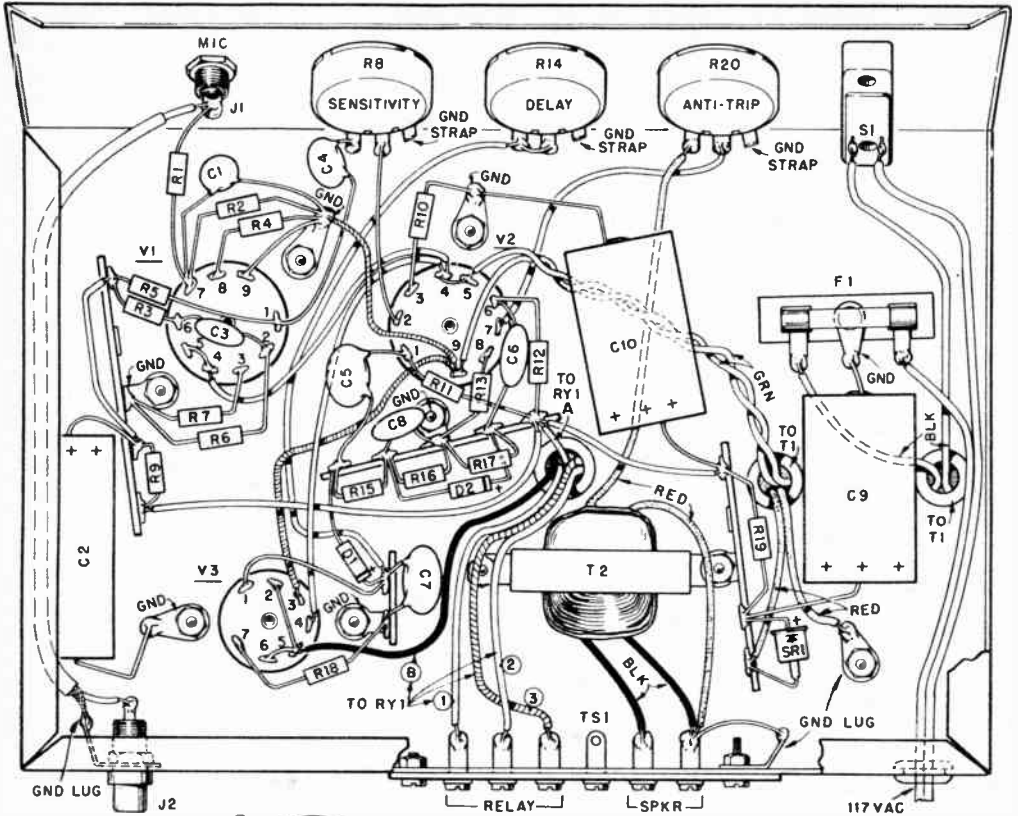

D1 and D2 have delicate leads, so handle carefully. Grip leads with pliers when soldering to prevent heat damage; and be sure the polarity is correct. Yellow band is cathode. Shield of cable from J1 to J2 is grounded at J2 only. Ground straps on R8, R14 and R20 are supplied with controls.

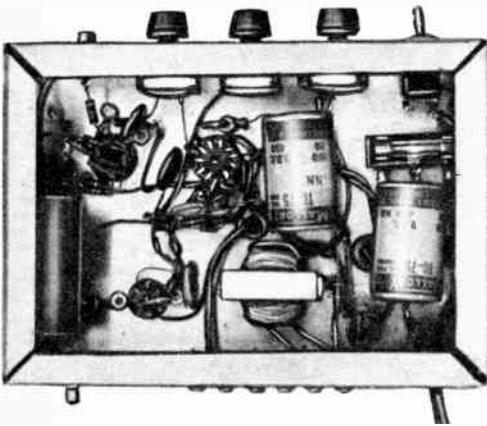

Space is at a premium under chassis. Wire the transformer, relay and all the filament leads first.

point X in the schematic. If even more gain is required, connect J2 to point Y in the schematic. In either case, ground only one end of the shielded cable. R1 and C1 are an RF filter and must not be omitted.

Twist and rout the filament leads as shown in the pictorial to keep down hum, and ground one of the filament leads to the chassis at V1. Connect two filament leads to all tubes. Do not use the chassis as common ground for one side of the filament line.

RY1 is an SPDT relay with a 5,000-ohm coil. We chose the contacts shown to illustrate typical connections. If you require additional contacts or use a different relay, be sure to use one that pulls in at about 4 to 6 ma. The pull-in current

PARTS LIST

Resistors: 1/2 watt, 10%, unless otherwise indicated
 R1—47,000 ohms R2—2.2 megohms
 R3,R5,R6,R11,R12,R15,R17 — 100,000 ohms
 R4,R7,R10,R13—2,200 ohms
 R8—100,000-ohm, audio-taper potentiometer
 R9—22,000 ohms
 R14—7.5 megohm, audio-taper potentiometer
 R16—4.7 megohms
 R18—1,500 ohms (see text)
 R19—470 ohms

R20—50,000-ohm, audio-taper potentiometer
 Capacitors: Ceramic disc, 500 V or higher unless otherwise indicated
 C1—.001 mf
 C2,C9,C10—20 mf, 450 V electrolytic
 C3,C4,C5,C6—.01 mf
 C7,C8—1 mf, 50 V or higher
 D1,D2—1N463A diode (Sylvania)
 J1,J2—Phono jacks
 S1—SPST toggle switch
 F1—1-amp fuse and holder
 RY1—SPDT relay, 5,000-ohm coil

(Potter and Brumfield LB-5 or equiv.; see text)
 SR1—Silicon rectifier, 750 ma, 200 PIV
 T1—Power transformer: 125 V @ 50 ma, 6.3 V @ 2 A (Allied Radio 62 G 411 or equiv.)
 T2—Output transformer: 5,000-ohm primary, 3.2-ohm secondary (Allied Radio 62 G 064 or equiv.)
 V1,V2—12AX7 tube
 V3—6AU6 tube
 Misc.—Chassis, cabinet, terminal strips

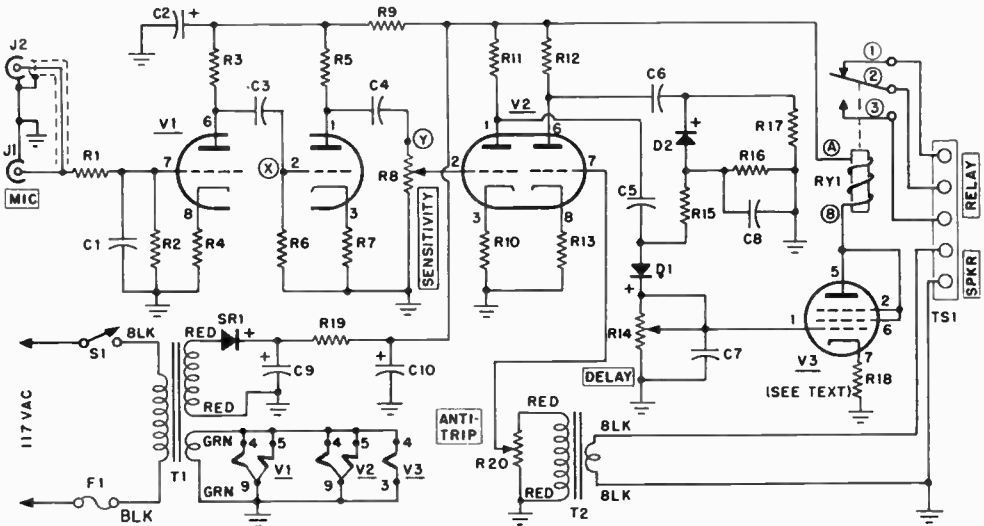

Mike voltage amplified by V1. V2 causes V3 to conduct. RY1 to close. R14, C7 time constant determines delay. Sound from speaker, amplified by right half of V2, rectified by D2, produces voltage at D2's anode offsetting mike voltage at junction of D1 and R15. This prevents RY1 from closing. Voltage at D1 when you speak in mike exceeds anti-trip voltage at D2, so D1, V3 conduct. RY1 closes.

determines the value of R18. For the specified RY1, R18 is 1,500 ohms. If you use a more sensitive relay with a pull-in current of about 4 ma, the relay may simply stay closed. If this happens, change R18 to 2,000 ohms. If RY1 still remains closed, change R18 to 2,400 ohms. But whatever relay you choose, be sure it has heavy contacts.

The voltage at RY1's terminals constitutes a shock hazard, so a cover should be put over the Com-Vox. The U-section of a 5x7x3-inch Minibox fits perfectly and can be held in place with small angle brackets. If you use a multiple-contact relay, replace TS1 with an octal socket.

Checkout. Connect a mike to J1, set R18 and R14 to mid-rotation and turn

on the power. Allow about a minute for warmup and then talk into the mike. RY1 should close as soon as you speak; if it doesn't, rotate R8 and R14 fully clockwise. If RY1 still doesn't close, look for a wiring error. If the wiring appears to be correct, check the voltage between D1's cathode and ground with a VOM or a VTVM connected to the grid (pin 1) of V3. As you speak, you should get an indication of approximately +15 volts DC. If this voltage is not present, see whether there is audio at the junction of C5 and R15. If there isn't, check V1's or V2's circuitry.

Next, connect the leads from your receiver's speaker to the speaker terminal lugs on TS1. Rotate R20 fully clockwise and adjust the speaker level to normal

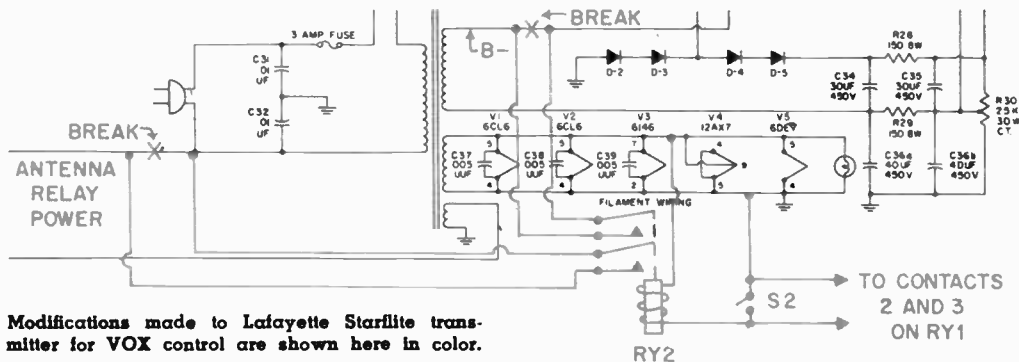

Modifications made to Lafayette Starlite transmitter for VOX control are shown here in color.

volume. If all is well you should measure between -5 and -15 volts DC between D2's anode (junction of R15 and R16) and ground. If voltage is not present, check for an audio signal at the junction of C6 and R17. If audio is present, the difficulty is in D2's circuit. If there is no audio, check the circuit around V2B.

Operation. Connect your microphone to J1 and, using a shielded cable, connect J2 to your transmitter's mike input. After setting R8 and R14 to mid-position, turn on the receiver and the Com-Vox. Adjust your receiver's speaker volume to slightly more than its usual level. Now turn R20 slowly until RY1 opens. Advance R20 an additional $1/16$ turn. R20 is now set so the sound from your speaker will not trip the Com-Vox.

Speak in a normal voice and advance (or retard) R8 until RY1 closes. Then advance R8 $1/16$ turn and then slowly adjust R14 until RY1 stays closed one-

half to one second after you stop talking (or you can set R14 for whatever delay you prefer). Since R8 and R14 interact slightly, you will have to juggle them a few times to get the correct setting.

After all adjustments are made, connect contacts 2 and 3 on RY1 to your transmitter's PTT switch leads.

If your transmitter lacks a PTT switch but has a panel-mounted mode switch, you still can use the Com-Vox. Mode switches usually are wired to set up the operating mode (CW or phone). They also connect the transmitter's power transformer B- lead to the chassis, thereby energizing the transmitter. The Com-Vox is used to make or break the B- connection to ground and to switch the antenna. The schematic above shows how to make the connections.

Mount a DPDT, 6-volt AC relay (RY2) on the transmitter chassis, connect one side of the coil to the 6-volt filament supply and the other side of the coil to terminal 3 of RY1 in the Com-Vox. Connect the other lead of the transmitter's filament supply (actually ground) to lug 2 of RY1. RY2 will now close when you speak into the mike.

One set of RY2's contacts completes the B- circuit and the other set controls the antenna-relay circuit. To use the Com-Vox, set the transmitter to the desired operating mode and *leave it there*. Every time you speak into the mike RY2 will close, switching the antenna and energizing the transmitter. To simplify transmitter tune-up, connect an SPST switch (S2) across RY1 contacts 2 and 3 so the transmitter can be kept on permanently. ●

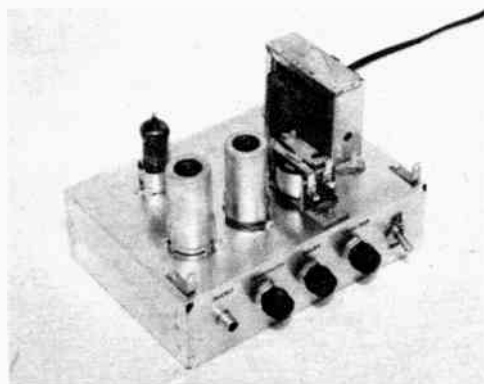

Top view of Com-Vox. Protective cover is held in place with brackets at front of the chassis.

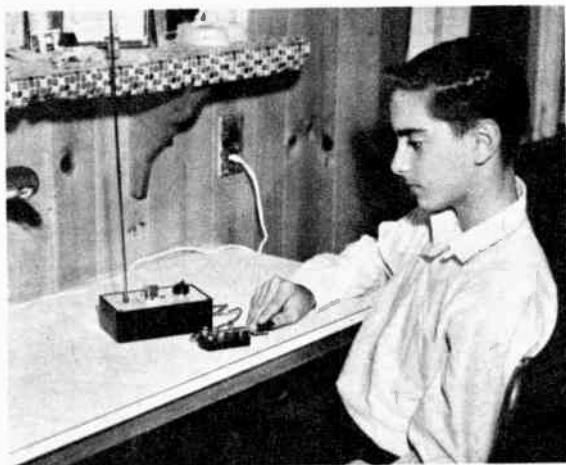

**Want new kicks from CB?
Try code on the License
Free Band. It's practice
for a ham ticket and the
transmission range beats
a pair of walkie-talkies.**

By Russ Cogan

Want to be a 'JUNIOR HAM'?

Every year thousands of Citizens Banders begin to feel cramped by the restrictions placed on them. They get the urge to experiment with their equipment, would like to chew the rag on the air, and may even want to try code. Obviously, CB isn't for them any more.

Ham radio is the answer—but for some, getting a ticket may seem to be too big a step. The easiest way to bridge the gap is with transitional equipment—and EI's Junior Ham Station is just that.

The two-transistor station consists of a 100-milliwatt CW (code) transmitter and a beat-frequency oscillator (BFO). You strap the BFO on any walkie-talkie (you don't have to modify the walkie-talkie in any way) with a 455 kc IF, enabling it to receive code. The advantage of learning code for your ham ticket this way is that you get a chance to practice on the air through hash and noise.

And the Junior Ham Station is perfect for new kicks (code) if you're tired of the same old CB routine but don't want a ham license.



JUNIOR HAM

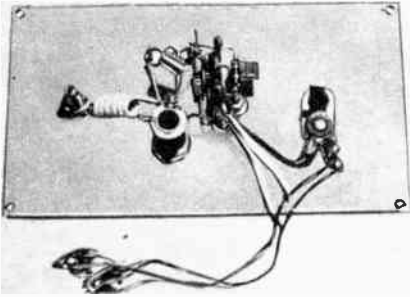

Transmitter takes little space on back of cabinet panel. Coil L2 is at left, J2 is at right.



Transmitter is a neat package. Be sure antenna is extended fully before starting the tune-up.

CW has a much greater range than voice, too. At the distance where 100-milliwatt walkie-talkie voice communication becomes unintelligible, a CW signal will come through loud and clear.

The Junior Ham Station operates on the License Free Band (see THE LICENSE-FREE BAND, May, '62 EI), so you don't need a CB license to get on the air. Just paste the Certificate of Compliance on the last page of this story on the back of the transmitter and you're in business.

One thing, though. You'll need a call. It isn't a legal requirement but it's a

quicker way to identify yourself than by using your name. Make up any number—it could even be your age or house number. But use a *number only*, no letters.

Construction. The transmitter can be built on the top panel of a 6¼x3¾x2-inch Bakelite box. The parts layout isn't critical but try to follow the pictorial as closely as possible. The parts specified must be used to comply with the conditions of the Certificate of Compliance.

Begin with coil L1, which is wound on a Cambridge Thermionic Corp. form (see Parts List). Scrape the enamel in-

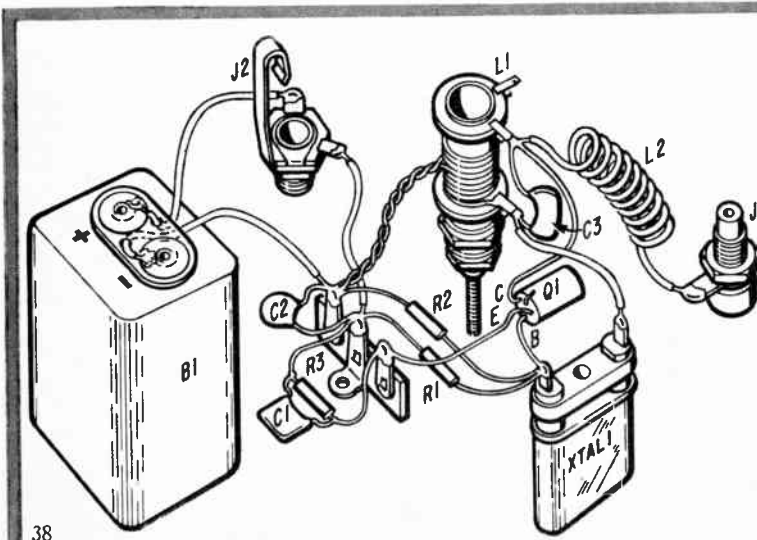

Before you mount L1, connect C3 across it and solder the lead which goes to crystal socket to lug near L1's mounting nut. L2 is ten turns of #22 insulated solid hookup wire close-wound on a ¼-inch-diameter alignment tool or a pencil. Note in schematic (right) that oscillator is turned on by the key (J2) when it closes, grounding battery's positive terminal.

sulation from the end of a piece of #22 enameled wire and solder it to one of the lugs near the mounting nut. Starting about an eighth of an inch from the form's collar, wind six closewound turns. Bring the wire out about three inches from the form, fold it back to form a loop, and wind six more turns in the same direction. Connect the end of this second winding to the lug at the bottom of the coil in line with the top lug you used.

Scrape the insulation from the loop back to a quarter inch from the form, twist the loop and apply solder. Further information about L1 and L2 is in the pictorial's caption.

The jack supplied with the antenna should not be used as it is not sturdy enough for even routine use. Instead, substitute a banana jack (J1) for it. Fill the hole in the back of a banana plug with solder and, while it is still hot, force the antenna into it as far as it will go.

The BFO is built on a 2 1/4 x 3 1/8-inch piece of perforated phenolic board. Flea clips are used for tie points. Parts values and layout are critical so don't make changes.

When you've finished wiring the BFO (connect C4 to L3 with #18 wire), glue grommets to the underside of the board at each corner. Temporarily fit the board in a plastic box to determine exactly where to drill a hole opposite C4's adjustment screw. After drilling the hole, put a little glue on the back of the

grommets and mount the board in place. Use electrical tape to hold the battery in position.

Transmitter Tune-Up. Install a third-overtone CB transmit crystal (same channel as the walkie-talkie's channel) and plug in the fully-extended antenna, making sure its tip isn't near metal. Turn L1's slug-adjustment screw full clockwise and plug a 15-ma DC milliammeter in J2. If the meter deflects to the left, reverse its leads.

Using a plastic alignment tool, turn L1's slug-adjusting screw counterclockwise. The current will rise to about 3 ma. Continue to turn the screw until the meter jumps to about 9 ma. Then give it another slight turn until the current rises to 11 ma.

Warning! Don't let the current go higher than 11 ma or the input power will exceed the 100 milliwatt legal limit. And Q1 will be damaged, too.

Remember, L1's adjustment always must be started with the adjusting screw turned full clockwise. If tune-up is started with it set elsewhere, the current will be the same but the crystal may start intermittently when you key the transmitter. Remove the meter, plug in a key and you're ready to send.

For best results use only quality crystals. The transmitter may fail to operate with off-brand crystals. We recommend crystals made by the James Knight Co., and those sold by Allied and Lafayette Radio for their own transceivers.

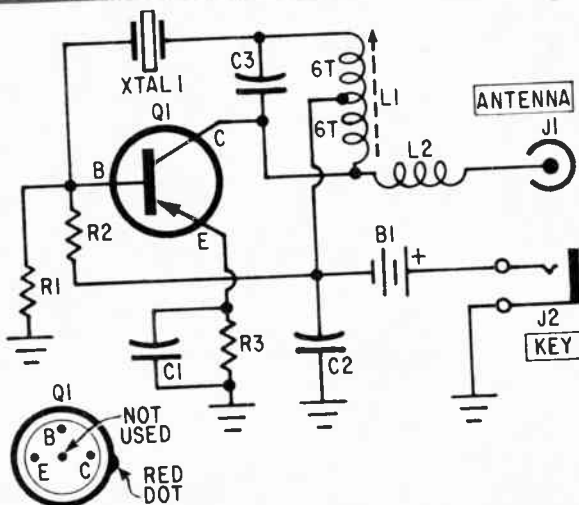

- PARTS LIST**
- Resistors: 1/2 watt, 10%
 R1—27,000 ohms R2—220,000 ohms
 R3—47 ohms R4—47,000 ohms
- Capacitors: 15 V or higher, ceramic disc unless otherwise indicated
 C1—.01 mf C2, C7, C8—.001 mf
 C3—15 mf silver mica
 C4—9.180 mmf trimmer capacitor (Lafayette C-733)
 C5—470mmf C6—47 mmf
- L1—Transmitter oscillator coil wound on Cambridge Thermionic Corp. form No. 1534-2-2 (old No. PL55-2C4L/B) Available from Newark Electronics Corp., 223 West Madison St., Chicago 6, Ill. Stock No. 40F3370
 L2—Antenna loading coil (see text)
- L3—Transistor oscillator coil (Lafayette MS-957)
- Q1—2N274 transistor Q2—2N412 transistor
- B1—9-volt battery (Eveready 246 or equiv.)
 B2—9-volt battery (Eveready 206 or equiv.)
- S1—SPST slide switch
 J1—Banana jack J2—Phone jack
 XTAL1—Third-overtone CB transmit crystal (see text)
- Misc.—Telescoping antenna (Lafayette F-343), plastic box (Lafayette MS-214), perforated phenolic board, flea clips

JUNIOR HAM

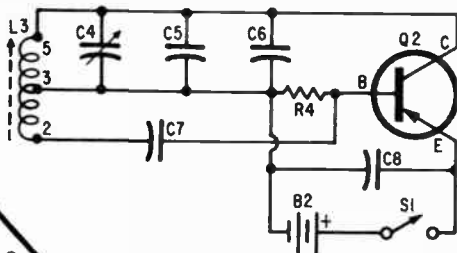
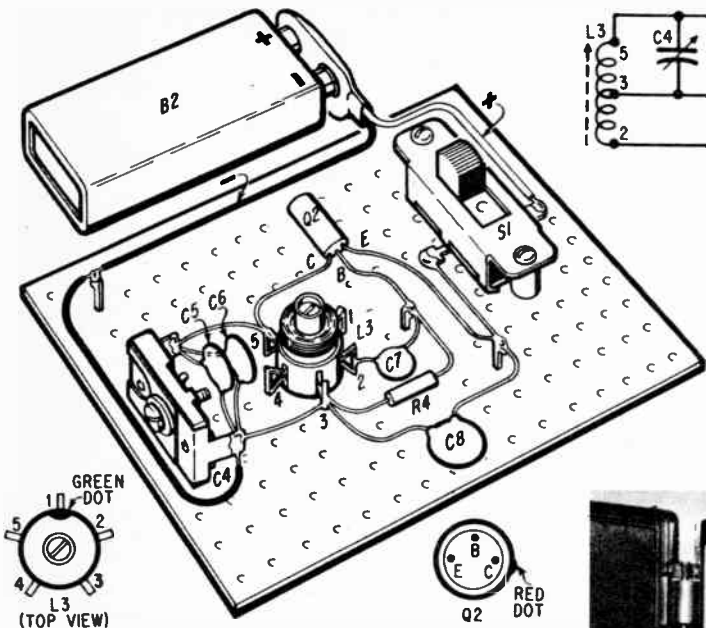

BFO schematic is above. Glue L3 to board with strong cement so it won't pull loose when connections are made to it. Mount S1 above board with 1/4-inch spacers or stack of washers. Do not mount the BFO in a metal cabinet. If you do, signal won't get out.

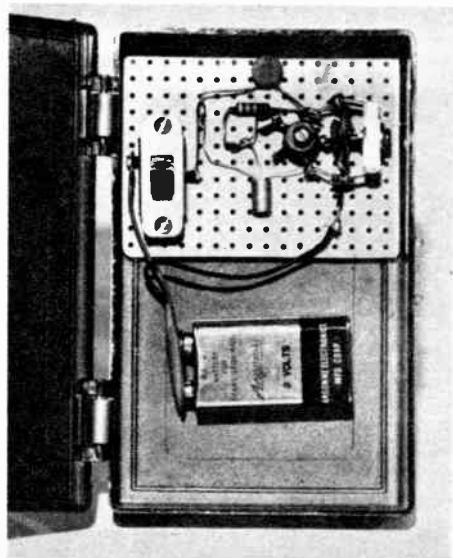

Before permanently mounting BFO board, drill hole in cabinet opposite C4 (upper right).

until the tone is loudest. This should be the BFO's normal operating position. Adjust C4 to change the frequency of the beat note.

Remember, when you operate on the License Free Band you can contact only other 100-mw stations. You *cannot* use the Junior Ham Station to work Class D (licensed) stations.

In a suburban area, the range of our station was about three or four blocks. And that was when the transmitter and antenna were in the basement. 📻

BFO Tune-Up. Using a plastic alignment tool, tighten C4's screw, then back off a half-turn. Attach the BFO to the walkie-talkie with a rubber band, near the speaker opening. Fasten down the transmitter key and adjust L3's slug until you hear a tone (beat note). Next, move the BFO around the walkie-talkie

CERTIFICATE OF COMPLIANCE WITH FEDERAL COMMUNICATIONS COMMISSION REGULATIONS, PART 15, PARAGRAPH 205

ELECTRONICS ILLUSTRATED certifies that this low-power transmitting device can be expected to comply with the requirements of Paragraph 15.205 of the FCC Regulations under the following conditions:

- When this device is assembled with components of the specified values and according to the diagrams and instructions published in this magazine.
- When used for the purpose and in the manner indicated in the instructions.
- When operated on a frequency between 26.97 and 27.27 megacycles and using an antenna limited to a single element not more than 5 feet long.

Robert M. Beason

ELECTRONICS ILLUSTRATED, New York, N. Y.
 dated: November 11, 1963

I hereby certify that I have assembled and adjusted this device in strict accordance with the above.

Owner's signature
 Date

Cut out this certificate, sign it and paste it on back of transmitter before you go on the air.

6-IN-1

CB SERVICE SET

Our complete tune-up laboratory fits into one small package!

WHAT MORE could you want for bench or field tune-ups than a complete lab in one neat package? Answer: nothing. And our 6-in-1 Service Set gives you a multi-function instrument that will permit you to do a full job on any Citizens Band transceiver. It's the most versatile, easy-to-operate piece or CB test equipment that you'll find anywhere. It's a snap to operate and will set you back only a few dollars. Take a look at what's in it and what it can do:

- Crystal-controlled IF oscillator (455 kc to 2 mc) for IF alignment.
- Crystal-controlled RF oscillator (CB channels 1 to 23) for front-end alignment.
- AF oscillator to modulate the IF and RF oscillators, and for checking the audio section of your transceiver.
- Third-overtone crystal checker.
- RF output meter for measuring the relative output power of your transmitter.
- VU meter for a visual indication of the receiver output level during alignment.

Best of all, the IF and RF oscillators don't have to be calibrated or tuned. And another big plus—the output level of the IF, RF and AF oscillators is vari-

able. There are no shared components in the Service Set so you can eliminate any circuit you don't need.

Construction. A 3x5x7-inch Mini-box will accommodate all parts without crowding. The IF, RF and AF oscillators are built as subassemblies on perforated phenolic boards; flea clips are used as tie points. Component values are critical and you should not make substitutions.

The Miller coil specified for L1 may not be available at all parts distributors. The printed-circuit equivalent (Miller 979) may be used instead, but it will have to be cemented in place. A Miller 954 would be a better choice. If you can't get Miller coils, use a Meissner No. 19-4551.

The IF and AF oscillators are built on

By Russ Cogan

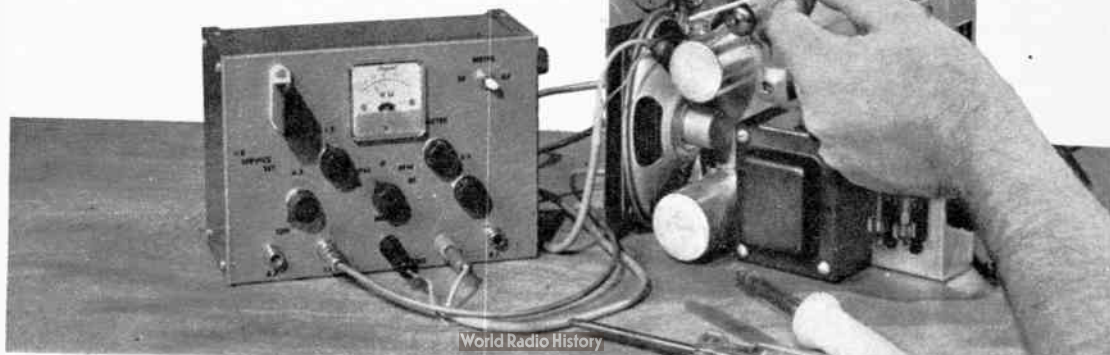

CB SERVICE SET

a 2½x4½-inch piece of perforated board, a close-up photo of which is on the last page of this story.

Cut Q2's and Q3's leads short and hold each with a pair of pliers to prevent heat damage when soldering.

Cover the right inside of the cabinet with electrical tape to prevent the flea clips protruding from the rear of the board from being shorted. A quarter-inch spacer or stack of washers will keep the board a safe distance from the cabinet. Center the board top and bottom so the Minibox cover will fit in place.

The IF-AF oscillator ground buss is connected to the cabinet through the board's mounting screws. To be sure of a good ground connection, scrape paint from the outside of the cabinet around the screw holes and use star washers under the screw heads.

The RF oscillator is built on a 1½x2¾-inch piece of perforated board. A photo of the board is on the last page of this story.

L2 is a home-brew coil and must be wound carefully. Scrape clean the end

PARTS LIST

- Resistors: ½ watt, 10% unless otherwise indicated
 R1—150,000 ohms R2—1,000 ohms
 R3—2.2 megohms
 R4, R12—50,000-ohm, linear-taper potentiometer
 R5—25,000-ohm, linear-taper potentiometer
 R6—270,000 ohms R7—33,000 ohms
 R8—680 ohms R9—10,000 ohms
 R10—15,000 ohms R11—4,700 ohms
 R13, R14—100 ohms, 2 watts
 R15—100,000-ohm, log-taper potentiometer
- Capacitors: 500 V ceramic disc unless otherwise indicated
 C1, C6—100 mmf C2, C12—.001 mf
 C3—50 mmf
 C4—5 mmf, silver mica
 C5—20 mmf, silver mica C7—.01 mf
 C8—.25 mf, 75 V
 C9—.1 mf, 75 V
 C10—30 mf, 15 V electrolytic
 C11—4 mf, 15 V electrolytic
- B1—9-volt transistor-radio battery
 B2—6-volt battery (Burgess Z4 or equiv.)
 L1—5 millihenry RF choke (Miller 650 or Meissner 19-4551. See text)
- L2—RF oscillator coil. Wound on Cambridge Thermionic Corp. form No. 1534-2-2 (old No. PLS5-2C4L/B) Available from Newark Electronics Corp., 223 West Madison Street, Chicago, Ill. 60606. Stock No. 40F370.
- T1—Transistor driver transformer (Lafayette AR-109)
- M1—YU meter (Lafayette TM-10)
 D1—1N34A diode
 Q1, Q2—2N274 transistor (RCA)
 Q3—2N217 transistor (RCA)
 J1, J2, J3—Phono jack J4—SO-239 coax connector
 J5, J6—Insulated binding posts
 S1—Two-pole, five-position rotary switch (Lafayette SW-78)
 S2—SPST switch on R12 S3—SPDT toggle switch
 XTAL 1—IF crystal. Available from Texas Crystals, 1000 Crystal Drive, Fort Myers, Florida. Prices are postpaid. 455 kc stock No. TX455; \$1.30. 1,001 kc to 1,600 kc, \$4.55; 1,601 to 2,000 kc, \$2.80. Except for 455 kc, specify frequency. Order FT-243 holder.
 XTAL 2—Third overtone CB transmit crystal
 Misc. — Crystal sockets (SO1, SO2), perforated board, flea clips, RG58/U coaxial cable

IF oscillator is in upper left corner of schematic. RF oscillator is in upper right corner. The AF oscillator is at lower left and meter circuit is at lower right. Any section can be omitted without affecting overall performance. For relative output power measurements, set S3 to RF and feed transceiver output to coax connector J4.

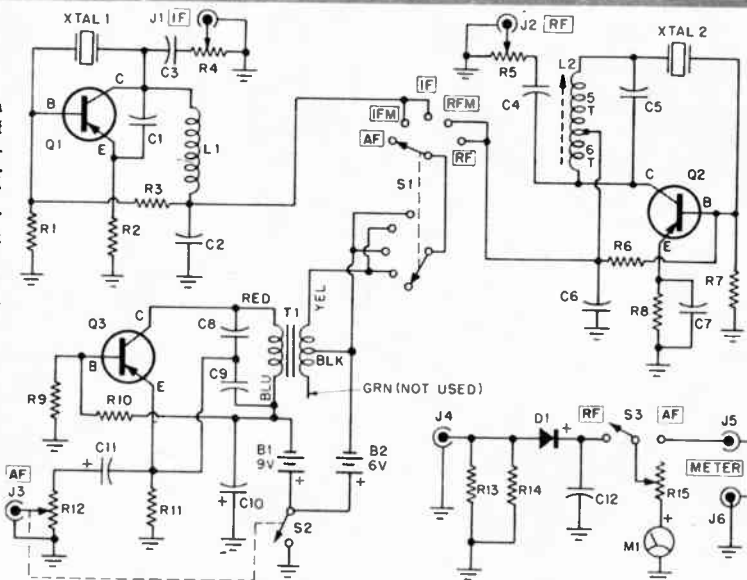

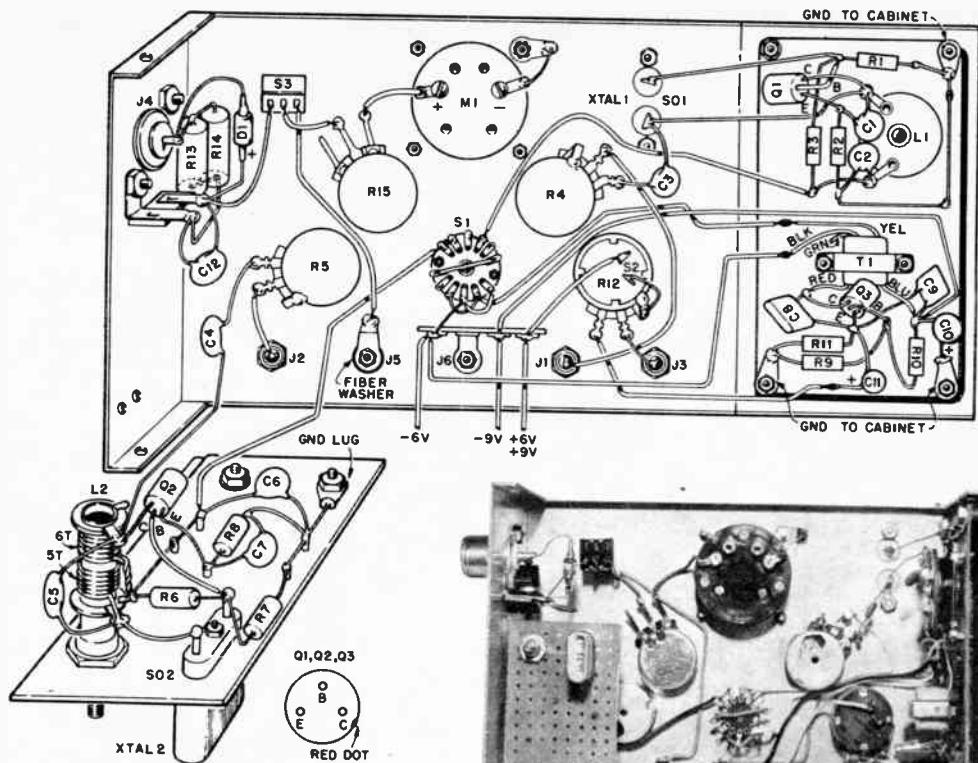

RF oscillator board has been pulled out and turned upside down in pictorial to show component location. Mount board as shown in photo, making sure the cover doesn't push up against XTAL 2.

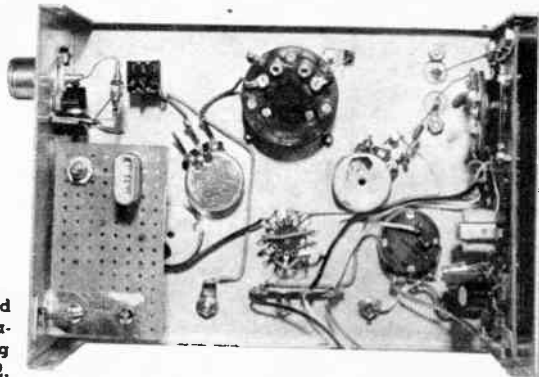

of a short length of No. 22 enameled wire and solder it to a lug on the coil form nearest the mounting nut. Starting $\frac{1}{8}$ -inch from the collar, close-wind five turns. Then, bring the wire out about two-inches from the form, fold it back to form a loop and wind six more turns in the *same direction* as the first five. Scrape the enamel insulation from the end of the wire and solder it to the bottom lug that is in line with the top lug. There should be about $\frac{3}{16}$ -inch space between the end of the six-turn winding and the form's bottom collar.

Scrape the enamel from the loop to within $\frac{1}{4}$ -inch of the form, twist and solder the leads together, and connect them to the other lug near the mounting nut.

Turn the slug-adjustment screw so the slug is a quarter of an inch in from the bottom of the coil form. The RF oscillator is now tuned and can be mounted to the cabinet with an L-shaped bracket.

Put a crystal in SO2 to be certain that

when the board is mounted, the cabinet cover fits in place.

Route the oscillator leads to the front-panel controls exactly as shown in the pictorial. Mount the batteries in the back of the cabinet and connect the leads to the terminal strip under S1. The IF and RF test leads should be about 3 feet long and must be made with RG58/U coaxial cable. The AF cable can be common shielded phono wire.

Using the Service Set. The RF crystal (XTAL 2), which goes in SO2 on the RF oscillator board, must be a third-overtone transmit type. It can be for any CB frequency, but we recommend a center channel such as 10 or 11.

The socket (SO1) for the IF crystal is on the front panel to make it easy to change crystals when working on transceivers with different IF's. Order a crystal with a frequency the same as your rig's IF and specify a FT-243 holder.

S2, which is on the AF output-level

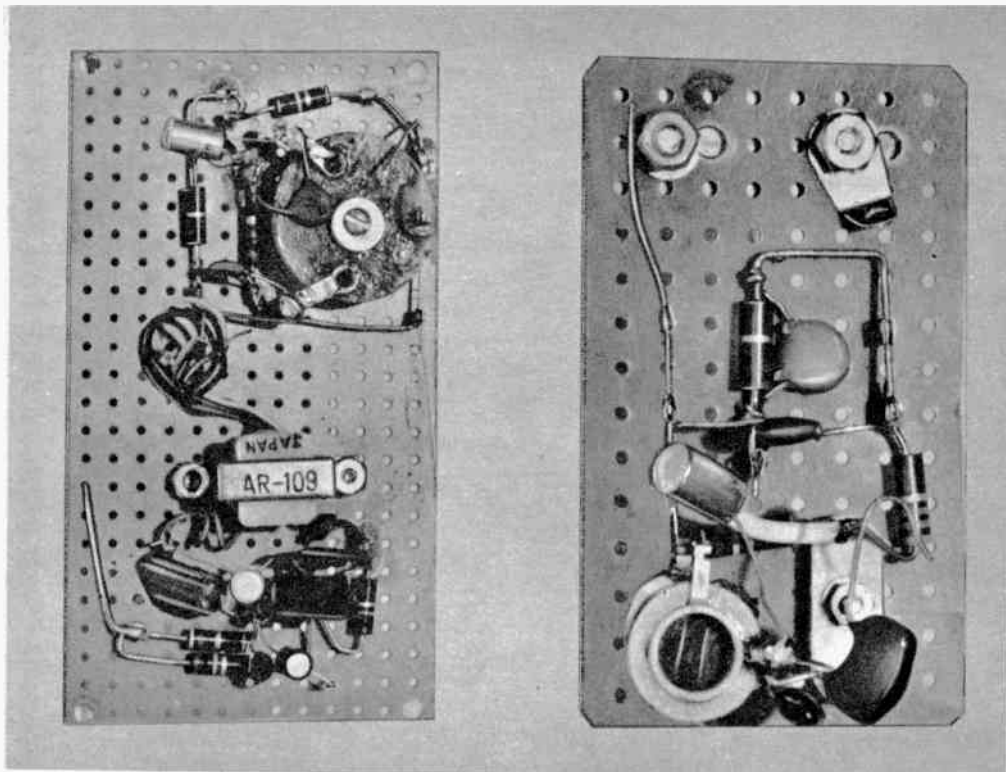

IF oscillator is at top of left board; AF oscillator is below it. Board shown at the right is RF oscillator.

CB SERVICE SET

control (R12) supplies power to all oscillators. Mode switch S1, activates only the circuits for which it is set. Going clockwise these are S1's positions: AF (audio oscillator), IFM (modulated IF), IF (unmodulated IF), RFM (modulated RF), RF (unmodulated RF).

The Service Set cannot check a crystal's quality but it can determine if it's the cause of intermittent transmitter operation. Plug the suspect crystal in SO2. If it has any life at all, you'll be able to pick up a signal on your receiver as our oscillator is guaranteed to start with a good crystal. If our oscillator works, check your transmitter's oscillator.

Transmitter Tune-Up. Connect your transceiver to J4 (R13 and R14 provide a 50-ohm load), set S3 to RF and tune the final for maximum deflection on M1. Adjust R15 for a convenient dial indication.

Receiver Alignment. Dual-conversion rigs should only be touched by the ad-

vanced CBer. Transceivers with crystal filters, frequency synthesizers and side-band circuitry should be returned to the manufacturer. However, a routine alignment job is handled this way: Connect the IF output (J1) to the grid of the converter tube, set S1 to IFM and connect J5 and J6 to the speaker terminals. Set the transceiver's volume control and R15 full clockwise. Adjust R4 to feed in just enough signal for a readable indication on M1. Following the alignment instructions supplied by the manufacturer of the rig, adjust the IF transformer slugs for a peak indication on M1. As M1's needle goes upscale, reduce the IF-signal level with R4. If the signal level is too great, the receiver's AVC will counteract your adjustments making correct alignment impossible. If your rig has an S-meter, set S1 to IF and adjust the IF transformers for peak S-meter indication.

To align transceiver front ends, set S1 to RFM, use the lowest possible input signal (control it with R5) and using the manufacturer's instructions, work for peak meter indications. ●



By Herb Friedman, 2W6045

SELECTIVITY—the ability of a receiver to reject a signal whose frequency is close to the one you want to listen to—is an absolute must for top quality Citizens Band reception. Many low-cost transceivers which are excellent in all other respects lack this one important feature which could make them hot performers all the way down the line. There are many ways to improve selectivity, but often they require major modifications to the receiver.

EI's Q-multiplier does a perfect job of narrowing your window on the band with the addition of only a capacitor and phono jack to the transceiver.

The multiplier is designed for transceivers whose IF frequency is between 1,200 and 1,800 kc. Other Q-multipliers often achieve so much selectivity (because they're designed for code reception) that speech is turned into mere mumbles. Our rig gives just enough to

reduce adjacent-channel interference without destroying speech intelligibility. And you need only a broadcast receiver to align it.

The multiplier can be used with any of your transceivers by simply plugging its connecting cable into a specially installed connector on the rear of the transceiver chassis. The rig's performance will be normal when the accessory is disconnected.

Construction. The multiplier will fit in the U-section of a 4x5x6-inch Mini-box. Wiring and parts layout are critical. Follow the plan shown in the photo of the inside. Further construction details are explained in the caption near the pictorial.

Drill a 5/16-inch diameter hole in the oscillator chassis and push L1 into it until its mounting tabs snap into place. The oscillator chassis is held in position by C3's mounting studs and screws.

Only the capacitor specified in the Parts List for C3 will fit in the chassis. Do not substitute a different type.

Transexiver Modification. Mount a phono jack on the rear apron of your transexiver's chassis close to the first IF transformer. Connect a .005 mf, 500 V capacitor from the center lug on the jack to the IF transformer lug that is connected to the plate of the mixer tube. Keep the capacitor away from the

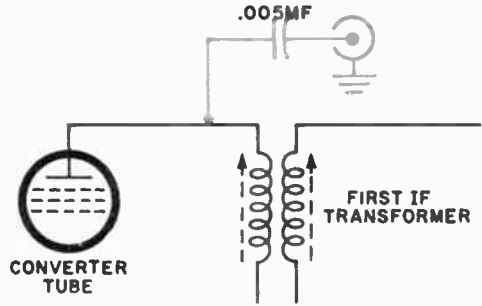

Portion of typical CB transexiver mixer/IF stage. Modification (tone) requires a .005 mf, 500 V capacitor be connected from plate of mixer to jack on chassis.

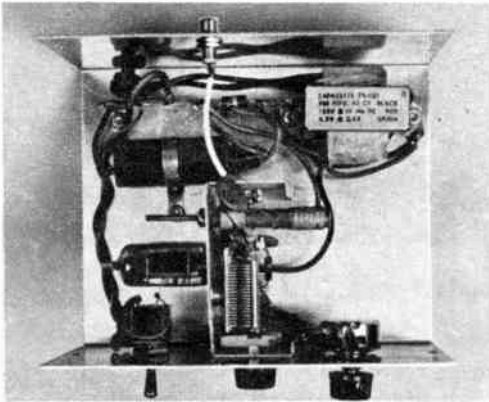

Wiring and parts layout are critical and should duplicate our model. Oscillator, built on separate chassis and held in place by C3, was turned upside down in pictorial to show parts location. Wire chassis first, then install it on its side as shown in the photo.

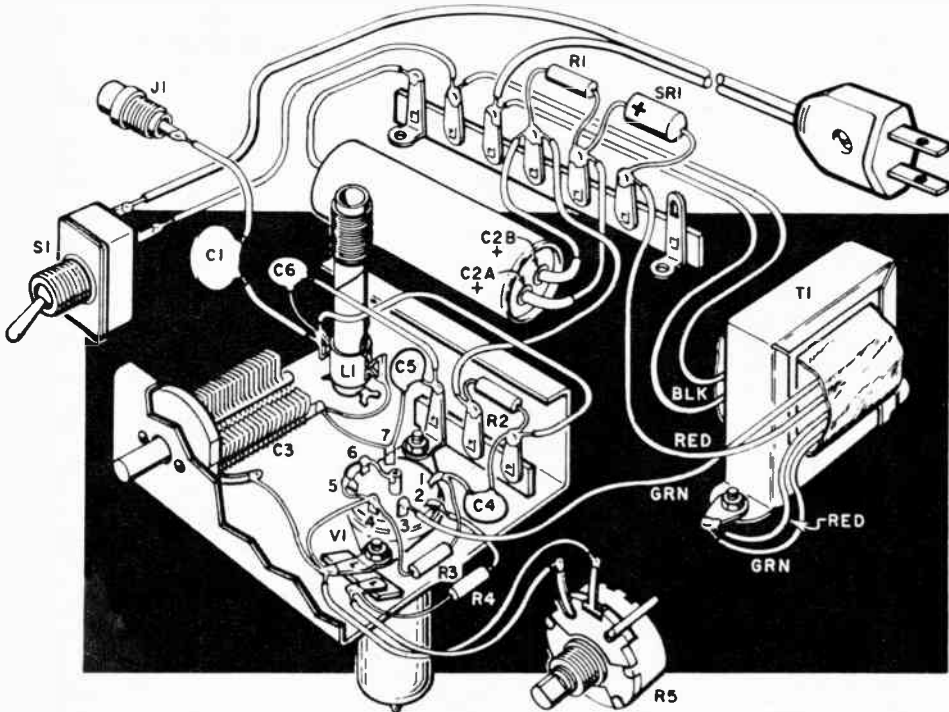

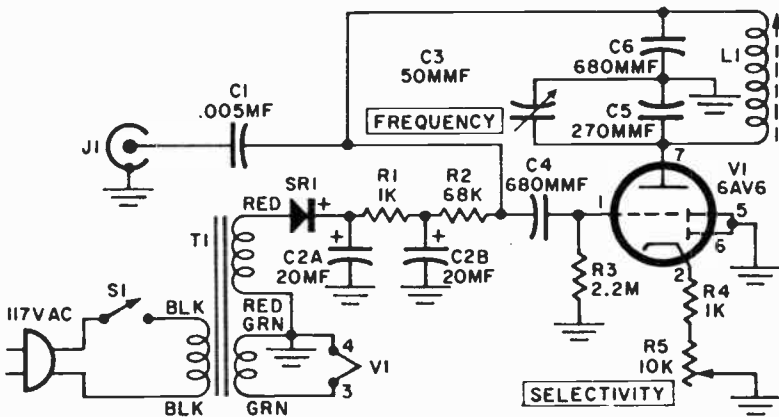

If Q-multiplier is to be used with CB transceivers with same IF frequency, C3 can be 50 mmf. If transceivers have IF frequencies that differ, use of 100-mmf trimmer for C3.

chassis and the transceiver bottom plate.

The cable to connect the Q-multiplier to the transceiver is made of two short lengths of insulated hookup wire (not shielded or coax cable) spread apart and terminated with standard phono plugs.

Aligning and Using the Multiplier. Set C3 so its plates are $\frac{3}{4}$ meshed. Turn L1's slug and R5 full *clockwise*. With the connecting cable plugged in the transceiver, turn the multiplier on but leave the transceiver off.

Place a broadcast or short-wave receiver tuned to about 1,600 kc near the connecting cable. Using a thin-blade screwdriver, turn L1's slug *counter-clockwise* until the radio becomes quiet.

Turn off the radio, set R5 full *counter-clockwise* and turn the transceiver on. Slowly adjust C3 for loudest sound or maximum S-meter indication. Then retune the transceiver and C3. Don't worry if the sensitivity appears to drop.

Next, advance R5 slowly. Eventually the multiplier will break into oscillation, causing a growl or whistle. Selectivity is maximum just below this point. Remember that while a Q-multiplier sharply reduces adjacent-channel interference, it can't eliminate interference from stations on the *same* channel.

In sharpening the selectivity, the circuit cuts off the received signal's sidebands, making speech sound muffled. When the received signal is in the clear, reduce the selectivity with R5 to restore sound quality.

Advancing R5 also increases the receiver's gain. As a matter of fact, gain may be greater than without the unit. After the multiplier is installed and you get the hang of using it, adjust the slugs of your transceiver's first IF transformer to further improve sensitivity.

It is not necessary to adjust L1 each time the Q-multiplier is used with a different rig. Simply adjust C3 for loudest signal and the Q-multiplier will be aligned to the new IF frequency. But remember, the multiplier can be used only with transceivers whose IF is between 1,200 and 1,800 kc. ●

PARTS LIST

- R1, R4—1,000-ohm, $\frac{1}{2}$ -watt, 10% resistor
- R2—68,000-ohm, $\frac{1}{2}$ -watt, 10% resistor
- R3—2.2 megohm, $\frac{1}{2}$ -watt, 10% resistor
- R5—10,000-ohm, linear-taper potentiometer
- C1—0.005 mf, 500 V ceramic disc capacitor
- C2—Dual 20 mf, 150 V electrolytic capacitor
- C3—3.2-50 mmf trimmer capacitor (see text). Hammarlund MAPC-50B (Lafayette HP-37)
- C4, C6—680 mmf, 500 V ceramic disc capacitor
- C5—270 mmf, 500 V ceramic disc capacitor
- L1—Ferrite loopstick antenna (Lafayette MS-11)
- T1—Power transformer: primary 117 VAC; secondaries, 125 V @ 15 ma, 6.3 V @ .6 A. (Lafayette TR-121 or equiv.)
- V1—6AV6 tube
- S1—SPST toggle switch
- SR1—100 ma, 400 PIV silicon diode
- J1—Phono jack
- Misc.—4x5x8-inch Minibox, $2\frac{1}{2}$ x $2\frac{1}{4}$ x $\frac{1}{4}$ -inch aluminum chassis (Premier ACH-1350)

GLANCE at the merchandise-for-sale columns in the papers or look over the second-hand equipment shelves at a hi-fi dealer and you'll notice many quality mono amplifiers for sale. They've been traded in for stereo. And when you give second thought to their price you'll realize quickly it's possible to go stereo for a lot less than you imagined.

But two mono amplifiers are difficult to operate. For one thing, speaker switching and phasing will involve disconnecting and reversing a lot of wires. Our switch box coordinates the amplifiers conveniently at their outputs.

Set mode switch S2 to *stereo* and amplifier 1 and amplifier 2 will be connected to speakers 1 and 2, respectively. Set S2 to *stereo reverse* and amplifier 1 is fed to speaker 2 while amplifier 2 drives speaker 1. If you haven't gotten around to buying a stereo cartridge and must use a mono job for mono records, set S2 to *mono* and amplifier 1 will drive both speakers. (An 8-ohm load resistor is then connected to amplifier 2.)

The two L-pads (R1, R2) come assembled together and have concentric shafts. This means you set the volume controls on both amplifiers to about the same position and adjust balance and volume to your own satisfaction with the easy-to-grip concentric knobs on the front of the switch box. Our model was built in a 9x7½x4½-inch wooden box, but you could use a metal cabinet. Only complicated job is assembling switch S2. It is made up of a Centralab index assembly and four rotary-switch sections. Assembly hints are in the captions on the next page.

The diagram on the right is a combination pictorial and schematic. The switch sections are shown in exact detail. Section A is mounted at the knob end of the switch shaft. If the impedance of your speakers is 8 ohms, connect the inputs at TS3 and TS4 to the corresponding impedance taps on your amplifier. If your speakers are 16 ohms, move the leads on the 4-ohm taps to the 8-ohm taps, and move the leads on the 8-ohm taps to 16-ohm taps (not shown on the schematic).

If speaker phasing is incorrect, flip S1, which reverses the leads to TS1. ⚡

going STEREO the EASY way

By Erwin V. Cohen



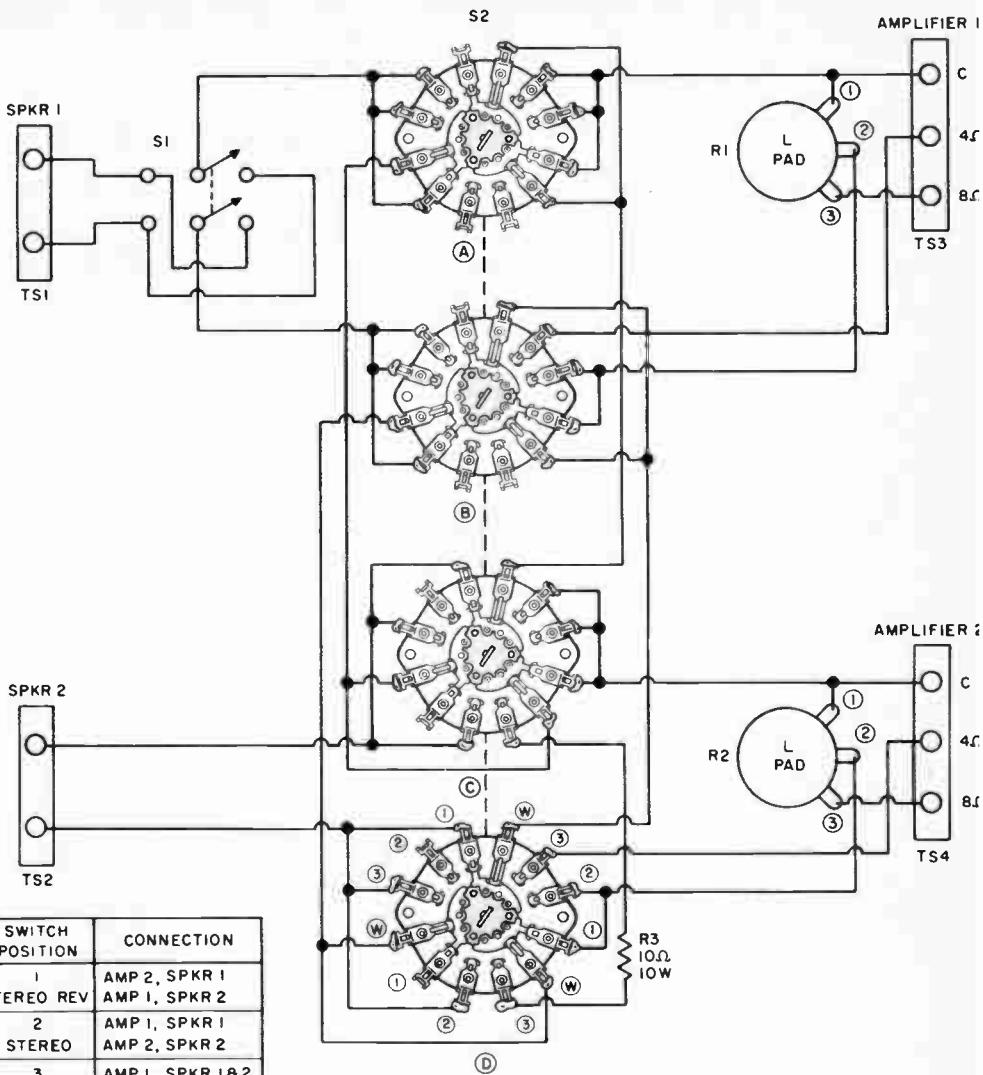

SWITCH POSITION	CONNECTION
1	AMP 2, SPKR 1
STEREO REV	AMP 1, SPKR 2
2	AMP 1, SPKR 1
STEREO	AMP 2, SPKR 2
3	AMP 1, SPKR 1 & 2
MONO	AMP 2, RESISTOR

SWITCH SHOWN IN POSITION 1

Circled numbers are switch positions. Wipers (color) turn counterclockwise from position 1.

PARTS LIST

R1, R2—Dual 8-ohm L-pad (Lafayette VC-55)
 R3—10-ohm, 10-watt wirewound resistor
 S1—DPDT rotary or toggle switch
 S2—Special switch made with Centralab P-271 index assembly (Allied Radio No. 35 B 498; \$2.10) and four Centralab LD phenolic sections (Allied Radio No. 35 B 158; \$1.05 each section) Stock numbers are from Allied Industrial catalog. Allow for postage when ordering.
 TS1, TS2—2-screw terminal strip
 TS3, TS4—3-screw terminal strip

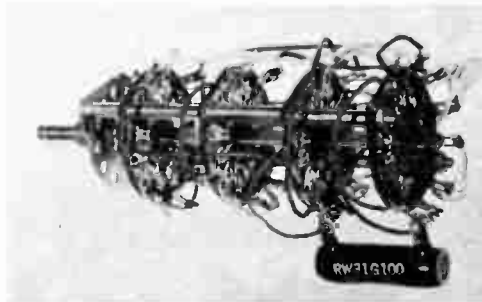

Be sure when assembling S2 that none of the sections are turned around 180 degrees. Use the wiper lug (circled W), near screw hole in section D at bottom of schematic, to guide yourself.

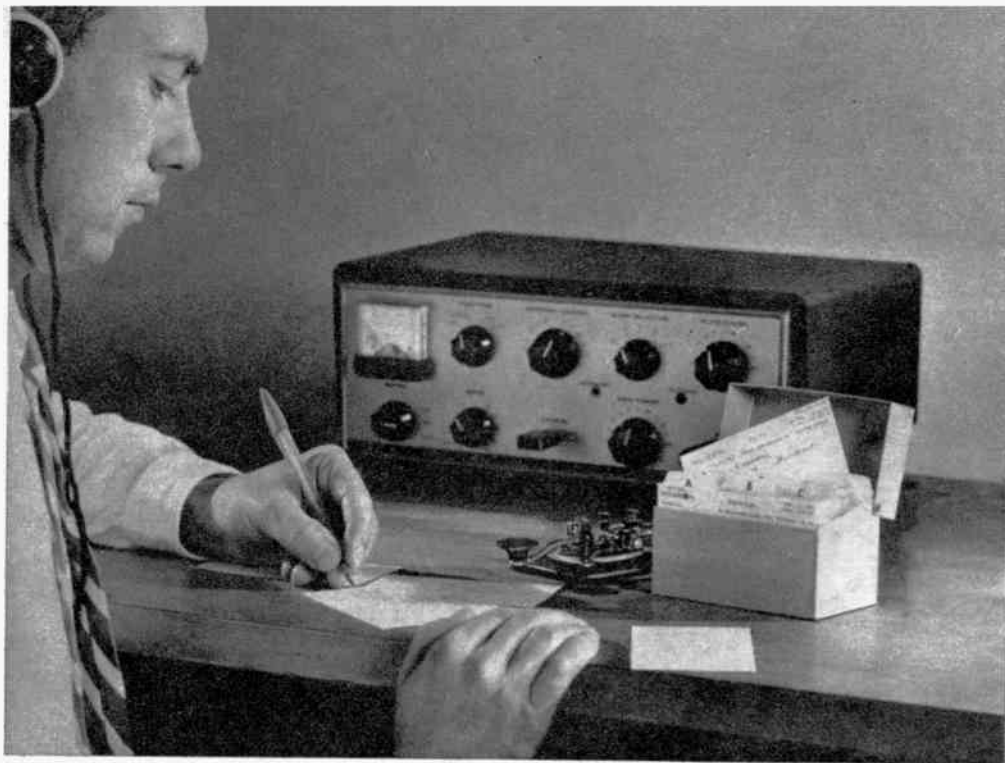

MEMORY BOX FOR HAMS

ELEPHANTS have terrific memories, or so the story goes. We don't know of any elephants who are hams, but we have run into a few rare hams with elephant-like memories. We also have come across ham after ham with perfectly normal memories, which is to say that theirs are pretty much like ours—about as good as a sieve. But that's where EI's Memory Box comes in.

Let's say the call letters of the station you're working are familiar to you and that you're super-certain you've worked the station before. But dollar-for-doughnut or kilowatt-for-key, you can't remember the other ham's handle, QTH or anything else about that previous contact. Solution? Easy—just call on EI's Memory Box.

As you can see from the photo, the Memory Box is nothing more than a common recipe holder which you can pick up at most any variety store for about 35¢. Inside are some ordinary 3x5 file cards and alphabetical index dividers. What you put on the cards is up to you, but call letters, name, address, telephone number, date, if and

when QSL cards were sent and received, and the like are all mighty useful bits of information.

The way you arrange the cards also is up to you, but it will depend in part on the type of operating you do. If most of your contacts are within the U.S., a straight alphabetical listing by call (ignoring the first letter and call area number) seems best. However, if you work a lot of DX, you might use a completely separate section of the Memory Box or even another Memory Box for foreign stations.

When establishing a contact or hearing a CQ, immediately flip through your Memory Box. If you haven't worked the station before, make out a new card as you're listening. And, if it's a station you've worked before, sit back with the assurance that you'll startle the guy at the other end with your marvelous memory. Meanwhile, of course, you can be adding more notes.

In short, nibble a few peanuts, and an elephantine memory is yours—if you have EI's Memory Box handy.

—Fred Blechman, K6UGT

THE AMPLI-MIKE

...incorporates mike and preamp in one case
...tailors your voice with volume and tone control

By Herb Friedman, 2W6045

EVEN though somebody once told you that you'd make a good radio announcer, you can't necessarily depend on your voice to knife through the airwaves when you're calling CQ on the ham bands or summoning one of your mobile Citizens Band units.

Each person's voice has different volume and frequency characteristics, and it's unusual for these factors to be at optimum for transmission of intelligence via two-way radio.

Most of the *energy* of the average voice is in the range of 90 to 500 cps. However, most of the *intelligence* is carried by the mid-range frequencies, from 500 to 5,000 cps, whose energy level is much lower. And most CB and ham transmitters don't have tone control to boost the level of this important band of frequencies.

By using the Ampli-Mike, you'll be able to produce maximum modulation and make your voice more intelligible at the receiving end. The Ampli-Mike also is equipped to boost or cut the overall level of your voice in case you're a natural whisperer or loud-mouth.

The Ampli-Mike consists of a microphone and transistor amplifier with volume and tone controls in one neat package. You can set the gain control for extra output if your voice is soft or if your rig is shy on modulation. Or, you can reduce the output if your voice is on the loud side. The frequency response can be adjusted to give you plenty of sock in the mid-range frequencies.

Construction.
Our Ampli-Mike



PARTS LIST

- Resistors: 1/10 watt, 10% unless otherwise indicated
 R1—47,000 ohms
 R2,R3—4,700 ohms
 R4—470 ohms
 R5,R7—5,000-ohm potentiometer (Lafayette VC-58)
 R6—100,000 ohms
 Capacitors: 6 volts or higher
 C1,C2—30 mf electrolytic (Lafayette CF-167)
 C3—1 mf electrolytic (Lafayette CF-128)
 C4—1 mf
 MIC—600-ohm dynamic microphone (Lafayette PA-74)
 Q1,Q2—2N220 transistor
 S1—DPDT subminiature push button switch (Lafayette SW-101)
 B1,B2—1 5-volt size AAA battery
 Misc.—Perforated board, flea clips, cabinet

is built on a 1 $\frac{7}{8}$ x3-inch piece of perforated board which is mounted in the main section of a 3 $\frac{1}{4}$ x2 $\frac{1}{8}$ x1 $\frac{5}{8}$ -inch Minibox. To keep the unit small enough to fit in the palm of a hand, we used miniature components throughout.

Use flea clips for all terminal points. Volume control R7 is a subminiature size intended for printed circuits. To mount it, insert three flea clips in a line (the tabs on R7 will line up perfectly with the clips) and press the tabs into

Microphone is mounted in 1-inch hole (cut with chassis punch) in perforated board. Secure microphone in place with a drop of epoxy cement at two points and let it set for 24 hours. Space is tight so use a small-tip iron and don't apply too much heat to the transistor or resistor leads.

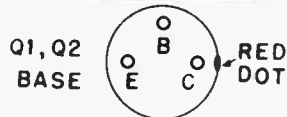
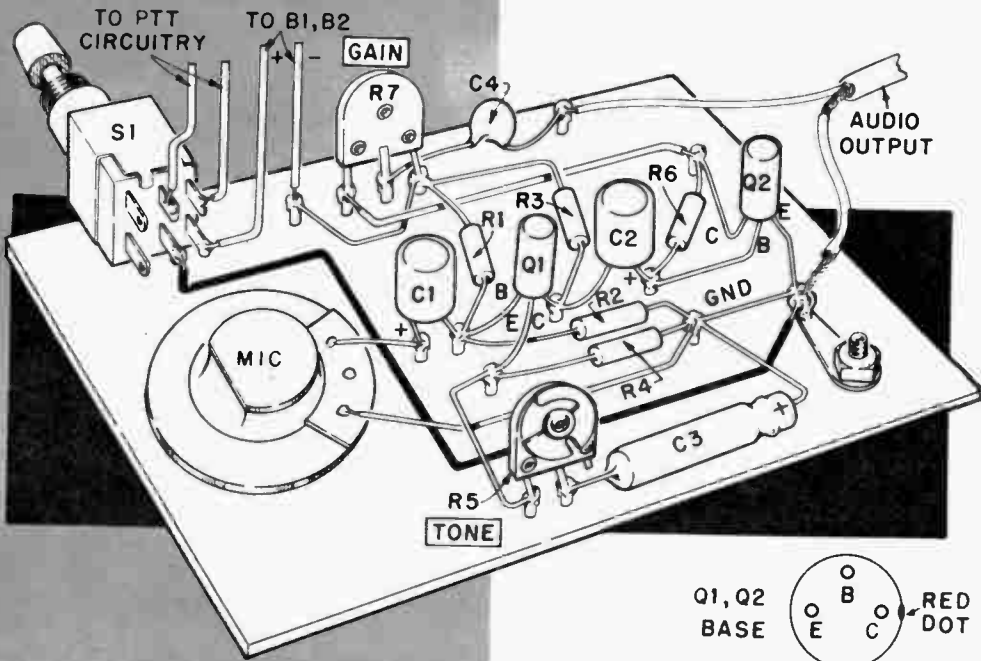
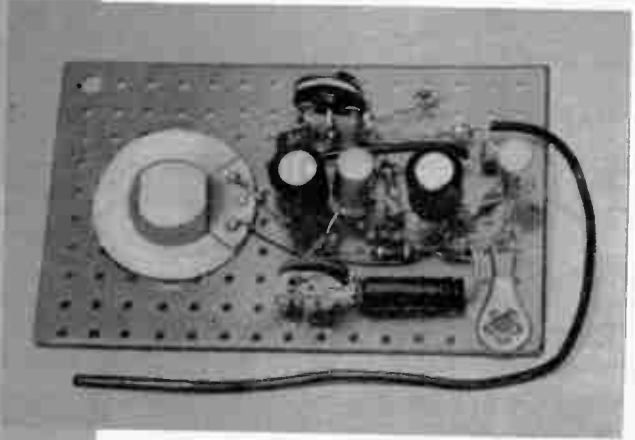

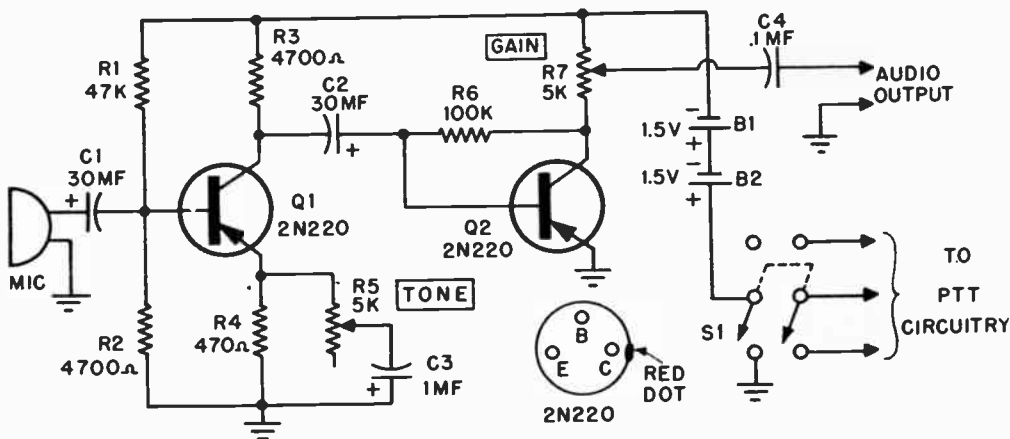

Gain of the first stage of amplifier increases at high frequencies as wiper arm of tone control R5 is moved toward end of control at emitter of Q1. PTT connection depends on the circuitry of your CB transceiver.

the clips. Apply a drop of solder.

Tone control R5 also is subminiature and is mounted similarly. However, only two of its tabs are used. Install R5 exactly as shown. Its right-hand tab is not connected and is cut short. Substitutions should not be made for Q1 and Q2, which are low-noise transistors.

Punch a 3/4-inch hole in the Minibox directly in front of the microphone and put a piece of grille cloth the same size as the perforated board on the inside of the Minibox. The cloth covers the microphone and acts as an insulator, preventing the flea clips from shorting against the metal cabinet when the board is mounted. Mount the board, using screws at diagonally opposite corners. A 1/4-inch grommet over each screw will keep the board away from the cabinet.

S1 is a miniature DPDT push button switch. Mount it on top of the Minibox so your operating finger rests comfortably on the button. One set of contacts applies power to the amplifier.

Use an ohmmeter to determine the other set of contacts that close when the button is depressed. These lugs should be connected to the PTT contacts in your transmitter's mike socket. If the PTT leads in your rig are disconnected when the PTT button is depressed, use a set of contacts on S1 that open when the button is pressed.

Drill 3/8-inch holes in the sides of the Minibox opposite R5 and R7 so they can

be adjusted when the cover is in place. Be sure to use shielded cable to connect the Ampli-Mike to your transceiver. Connect the shield to the Minibox with a lug under one of the perforated board's mounting screws.

B1 and B2 are AAA penlight cells. Since the amplifier's current drain is low, the batteries will last many months, even with heavy use. Mount the battery holder on the Minibox cover, making certain it does not touch any of the components when the cover is in place.

Plug in the Ampli-Mike, depress S1, speak in a normal voice and adjust R7 to achieve as close to 100% modulation as possible. Set R5 for best tone.

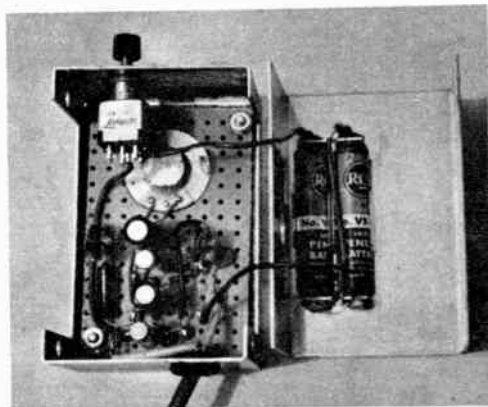

Batteries can be mounted on the back of the cabinet with a Keystone No. 138 battery holder.

CB Crystal Checker

Sure-fire gadget spots sluggish crystals in a matter of seconds.

By Herb Cenan



EVERY Citizens Bander knows his transmitter's gotta have a crystal because of that .005 per cent frequency-stability requirement. But crystals do more than establish frequency. To a degree, they also determine output power and receiver sensitivity. Best way to find out how good they are in this respect is to check what's called their *activity*.

EI's checker puts third-overtone crystals through their paces in a commonly used transmitter oscillator circuit which gives a visual indication of their condition. Construction details are explained in the captions for the pictorial and the photo of the inside of the unit.

Adjustment and Calibration. Turn L1's slug full *counterclockwise* and close C1's plates. Install a knob on C1's shaft so the pointer is at the 9 o'clock position. (C1's plates should open when the knob is turned clockwise.)

With C1's knob set at 9 o'clock, turn R3 three-quarters clockwise, insert a crystal you know to be good in SO1 and turn on power. After a one-minute warm-up, *slowly* turn C1 clockwise until M1 jumps to some peak value. Then carefully turn C1 counterclockwise until M1 peaks again, but at a point higher on the scale. If you miss this point—that is, if the needle falls back to zero—start all over again to get the needle to stay

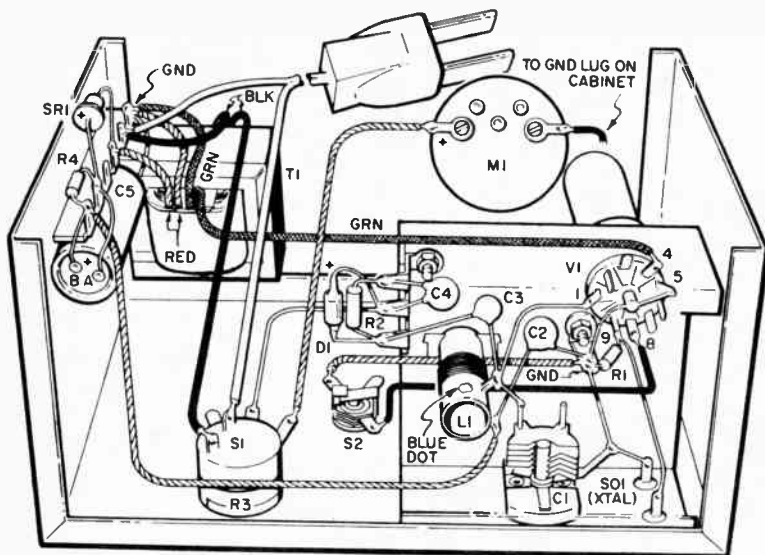

Oscillator, built as subassembly on a $2\frac{5}{8} \times 2\frac{3}{4} \times 1\frac{1}{4}$ -inch chassis, is mounted in main section of $3 \times 4 \times 5$ -inch Minibox. Chassis is held in position by C1's and SO1's mounting screws. Mount it so top of V1 will not prevent cover from being slipped in place. Layout is not critical but lead from pin 9 on V1 must be kept away from chassis. Drill a few holes in cabinet above V1 and opposite its base for proper ventilation.

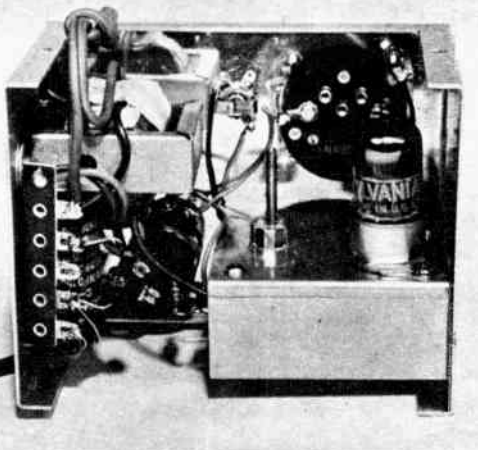

at the higher peak. Push S2. The needle should fall back to zero and remain there after S2 is released. Continue to turn C1 clockwise a bit until the needle jumps to a peak again. This is your reference point on the scale for a good crystal. Adjust R3 for any other convenient reference point around mid-scale.

Operation. Insert a crystal to be tested and repeat the entire procedure—turning C1 clockwise for a peak, backing C1 off for a higher peak, pressing S2 to zero M1 and turning C1 clockwise for another peak.

If the indication is close to the reference, the crystal is good. If not,

Many parts must be squeezed in tight quarters so install the transformer, filter capacitor, rectifier, terminal strip, meter and potentiometer in Minibox first. Build oscillator on chassis and install last.

the crystal may be the cause of lowered transmitter output power or poor receiver sensitivity.

When C1 was first turned clockwise M1 peaked, if you recall, at a slightly higher point than it did after S2 was pressed. The first indication is not meaningful since the oscillator has not yet proved itself able to start dependably. For this reason, the reference point is established after the oscillator is stopped by pressing S2.

Pressing S2 simulates what happens when component aging detunes the transmitter's oscillator, causing it to start intermittently. If the crystal is good, the oscillator may be detuned.

Always check transmit crystals against transmit crystals and receive crystals against receive crystals—not against each other. And don't use a receive crystal from one manufacturer's rig as a reference for a receive crystal from another manufacturer's equipment. While it is wise to do the same with transmit crystals, many transmitters have the same oscillator circuit, sometimes allowing crystals to be interchanged.

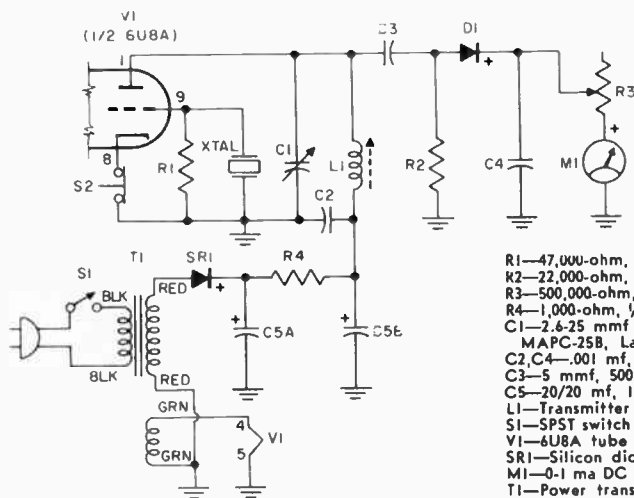

Only triode half of V1 is shown; pentode section is not used. Full-scale deflection can be obtained with 0.1 ma meter. A 25 mmf capacitor for C1 will check any 20-30 mc crystal. A 15 mmf capacitor for C1 will provide less-critical check of any rock between 25-29 mc.

PARTS LIST

- R1—47,000-ohm, 1/2-watt resistor
- R2—22,000-ohm, 1/2-watt resistor
- R3—500,000-ohm, log-taper potentiometer
- R4—1,000-ohm, 1/2-watt resistor
- C1—2.6-25 mmf variable capacitor (Hammarlund MAPC-25B, Lafayette HP-35. See schematic caption.)
- C2, C4—.001 mf, 500 V ceramic disc capacitor
- C3—5 mmf, 500 V ceramic disc capacitor
- C5—20/20 mf, 150 V electrolytic capacitor
- L1—Transmitter oscillator coil (Lafayette HP-60)
- S1—SPST switch on R3 S2—SPDT push-button switch
- V1—6U8A tube D1—1N34A diode
- SR1—Silicon diode; 100 ma, 400 PIV or higher
- M1—0.1 ma DC milliammeter (Lafayette TM-11 or equiv.)
- T1—Power transformer: 117 V primary; secondaries, 125 V @ 12 ma, 6.3 V @ .6 A (Lafayette TR-121 or equiv.)
- SO1—Crystal socket (Allied Radio 72 S 075)
- Misc.—3x4x5-inch Minibox, 2 1/4 x 2 3/4 x 1 1/4-inch aluminum chassis (Premier ACH-1350), terminal strip



The 'MINI R'

By Brice Ward

A palm-size resistance substitution box that goes from 1 to 1,111,110 ohms in 1-ohm steps.

CUT and try are the key words when determining the exact parts values required to get an experimental project to work properly. And when it comes to resistors, not only is it impossible to have *all* values at hand, it is a nuisance to keep trying different sizes until you find just the right one. Wiring a pot in the circuit, adjusting it, then removing it to measure its value isn't the fastest or most convenient way, either.

Solution—the Mini R—a resistance substitution box which, at the flick of a switch gives you resistance up to 1,111,110 ohms in 1-ohm steps. The Mini R, which uses 1 per cent, ½-watt resistors, isn't much larger than a pack of cigarettes and could easily get lost on your workbench.

To save time and money, you can purchase a complete kit of parts and assembly instructions for \$18.95. The parts list gives the details.

How does it work? Simple! Take a look at the schematic and consider just the first decade, made up of S1 through S4 and the 1-, 2-, 3- and 4-ohm resistors, and assume J2 is connected to the bottom of the 4-ohm resistor.

When all switches are open the resistance between J1 and J2 is 10 ohms. Close S2, S3 and S4 and 1 ohm is left. Open S2 and you've got 3 ohms. Close

S1 and S3, open S2 and S4 and you get 6 ohms. Close S1 and S2, open S3 and S4 and you've got 7 ohms. And so it goes right down the line with the five other decades which are connected in series.

With all switches open, the resistance between J1 and J2 is 1,111,110 ohms. Start off with all switches closed and open only those that add up to the value you require.

Construction is a snap. We mounted all 24 switches on a 2-11/16x3¼x1/32-inch-thick panel. Further construction details are covered in the diagrams and captions on the opposite page.

To save space only one 2-56x½-inch machine screw is used to hold two adjacent switches. Cut the rectangular hole for the switch slider by drilling two ⅛-inch holes and filing them out. ●

PARTS LIST

- Resistors: ½ watt, 1%
 1,2,3,4,10 ohms—Continental Wirt Type NA-15 (48¢ ea.)
 20,30,40 ohms—Continental Wirt Type NA-15 (65¢ ea.)
 100 through 400,000 ohms—Continental Wirt Type CF-15 (54¢ ea.) Resistors are available at prices listed above, plus postage, from Center Industrial Electronics, 74 Cortlandt St., N. Y., N. Y. 10007.
 S1-S24—Continental Wirt Type G-126 midget DPDT slide switch. Available for 29¢ each for the lot from Newark Electronics Corp., 223 West Madison St., Chicago, Ill. Stock No. 23F527.
 Kit of parts including case, punched panel, resistors, switches, wire and connectors is available for \$18.95 postpaid from Techni-Kits, Inc., 350 Broadway, N. Y., N. Y. 10013.

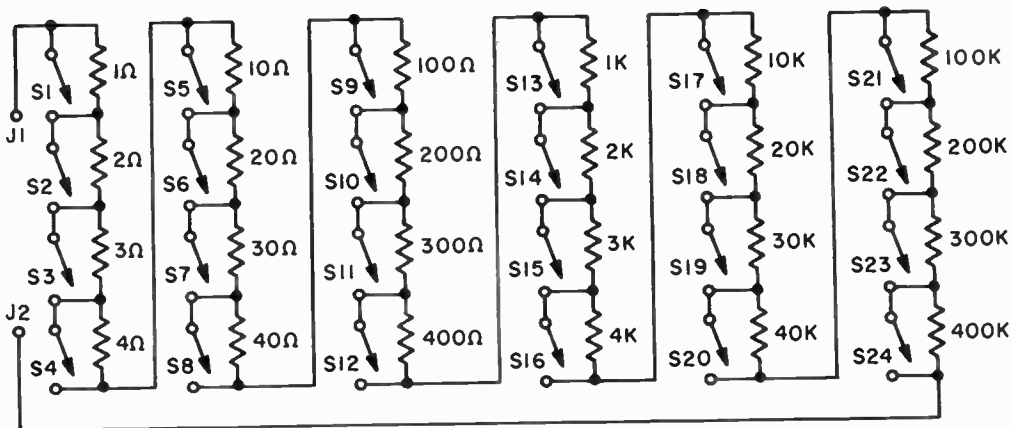

When all switches are open, resistance between J1 and J2 is 1,111,110 ohms. Closing a switch subtracts value of the resistor associated with it. Close S23 and resistance at J1, J2 is 811,111 ohms.

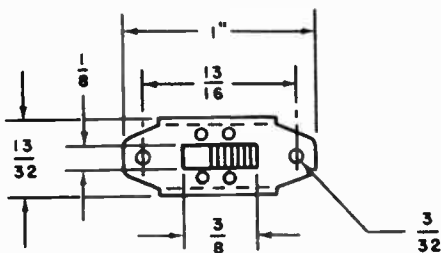

If you plan to cut and drill your own panel, use the dimensions above for the special miniature switches we have specified in parts list.

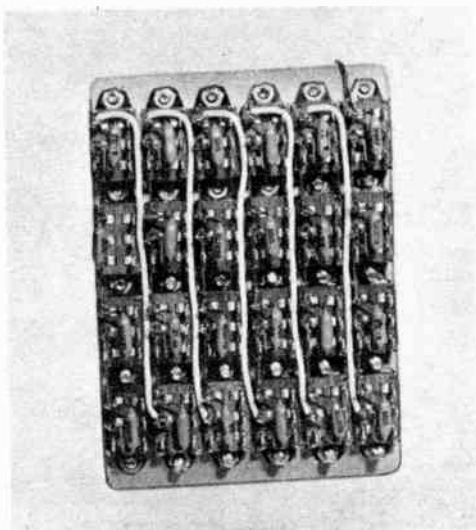

Space is tight so watch out for shorts. A small-tip iron will make the wiring job much easier.

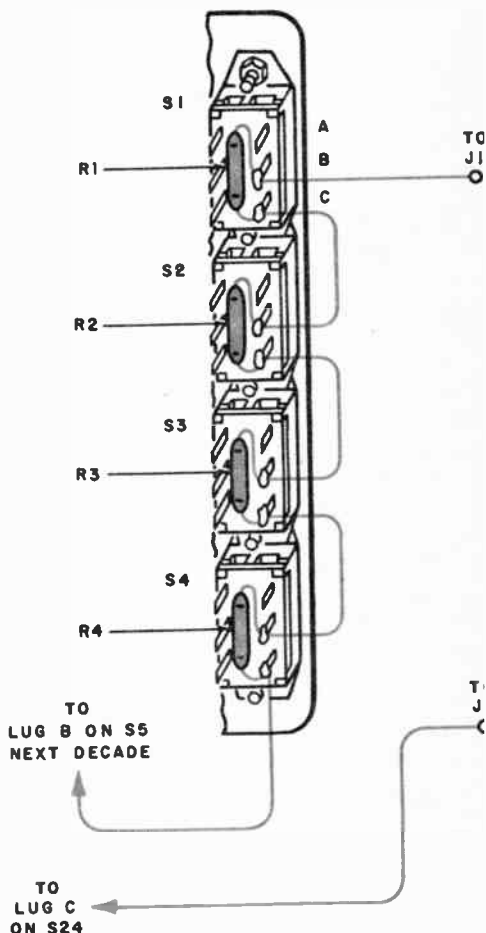

R1, R2, R3, R4 correspond respectively to 1-, 2-, 3- 4-ohm resistors. Wire other decades similarly

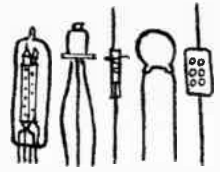

**BEGINNERS
PAGE**

build your own AC GENERATOR

AC power is widely used and taken for granted. Although we know why we need it, we never give much thought to how we get it. Our project, an AC generator, demonstrates the process of converting mechanical energy into electrical power. The generator consists of a rotating magnet and a coil of wire wound on a large iron bolt. As you turn the magnet past the head of the bolt, a current is induced in the coil which we will observe on a meter.

First, wind 800 turns of No. 28 or No. 30 enameled wire on a 2- or 3-inch long iron bolt. Leave about one-quarter inch of threads clear for mounting the bolt in the wood block. Scrape the enamel insulation off both ends of the wires and connect them to the terminal clips.

The next step is the mounting of the magnet and the construction of its support. We glued a small magnet from an old damaged PM speaker to the end of a wood dowel. Push the dowel through a hole in the support block and force a crank, made with a piece of coat-hanger wire, in a hole in the other end of the dowel.

Get hold of a 0-1 ma DC meter and adjust the zero-set screws so the needle comes to rest about mid-scale, allowing it to swing left and right. Connect the meter to the output clips. As you turn the crank, the needle will move to the left and right of its resting point, indi-

cating the generator output is an alternating current.

The electricity we generated started with a source of energy—the force exerted by your hand. As the moving magnetic field passes the head of the bolt, it produces a fairly high output current because of the combination of a large coil of wire and large bolt. In addition to being a form for the coil, the iron bolt provides a good magnetic path between the magnet and the coil.

The meter needle, moving from left to right, shows that the direction of the magnetic field determines which way the current flows. Rotate the magnet very slowly and watch the

needle. As one end of the magnet approaches the bolt, the needle moves in one direction. As the same end of the magnet moves away from the bolt head, the current reverses direction.

The speed at which the magnetic field moves past the bolt affects the magnitude of the current. The faster you turn the crank, the greater the current. This illustrates an important principle: The more magnetic lines that cross the wire *per second*, the higher the current.

Our rotating magnet and coil correspond, respectively, to the armature and field coil in a car's generator. Our generator only produces a few thousandths of a watt of power. The car generator gives over 300 watts.—H. B. Morris

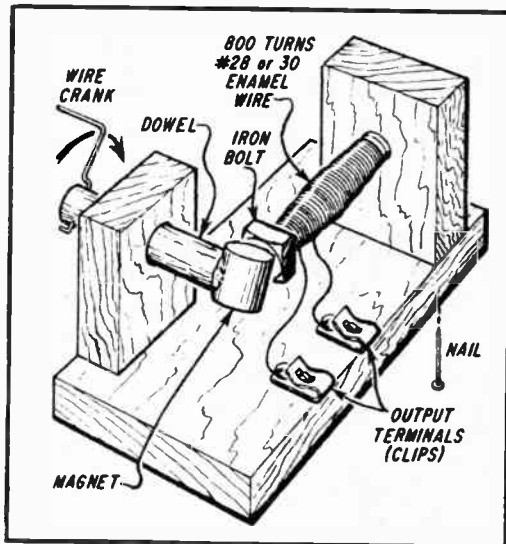



VOICE-POWER AMPLIFIER

Microphone preamp with adjustable frequency range tailors mike response to any voice.

By Russ Cogan

A SERIOUS deficiency of most CB rigs is that microphone amplification is established at a value which gives eighty-five to one hundred per cent modulation with an "average" voice. Unfortunately, voices are not average; some are loud, others are soft. Some people tend to swallow the mike—others act as though it had halitosis. All these factors help determine the per cent modulation. Frequently, in order to achieve 100% modulation with a comfortable voice level additional microphone amplification is needed.

EI's CB Pre-amplifier will provide the additional gain needed to fully modulate the transmitter. Since the preamp is transistorized, it is easily connected to either your base or mobile transceiver without tapping its internal wiring. The low current drain will give a battery life of many months. Level control R1 permits adjustment of the pre-amplification to the exact value required for your voice and mike habits.

As an added feature, the preamp is designed for low-frequency attenuation thereby providing a crisp communications quality. In addition, a variable high-frequency tone-shaping control is provided. By proper adjustment of control R5, audio quality can be varied

from sharply crisp to smoothly mellow.

The preamp is wired on a 2x3 $\frac{3}{4}$ -inch piece of perforated board. Before installing the components drill a hole in each corner of the board for the mounting screws; use a #28 drill for 6-32 screws. Input transformer T1 is held to the board with flea clips. Carefully bend T1's mounting tabs so they are at right angles to T1's frame. Place T1 on the board and insert a flea clip through the tab and board. A small drop of solder applied to the flea clips on the underside of the board will hold T1 firmly in place.

All the other board components are wired to flea clip terminals. The component leads are short so take care not to use excessive soldering heat. Use a heat sink (such as an alligator clip) when soldering transistor Q1.

The battery is held in place by brackets made from cable clamps or a strap can be cut from a tin can.

After the battery is in place mount the perforated board in the cabinet. To avoid short circuiting the flea clips which extend through the board, place a quarter-inch spacer or stack of washers between the cabinet and the board at each of the four mounting holes.

Input jack J1 is selected to mate with

Resistors: 1/2 watt, 10% unless otherwise indicated
 R1/S1—10,000 ohm pot with switch
 R2—100 ohms
 R3—100,000 ohms
 R4—10,000 ohms
 R5—50,000 ohms miniature pot
 Capacitors: All rated at 10 VDC or higher
 C1—.05 mf miniature
 C2—30 mf electrolytic
 C3—8 mf electrolytic

PARTS LIST

C4—10 mf electrolytic
 C5—.02 mf miniature
 B1—9-volt transistor radio battery
 Q1—2N109, 2N217 transistor or equiv.
 T1—Transformer: 200,000 ohms primary; 1,000 ohms secondary (Lafayette Radio TR-120 or equiv.)
 PL1, J1—see text
 Misc.—Perforated board (3 1/2"x2"); flea clips; Mini-box (5/4"x3"x2 1/4"); etc.

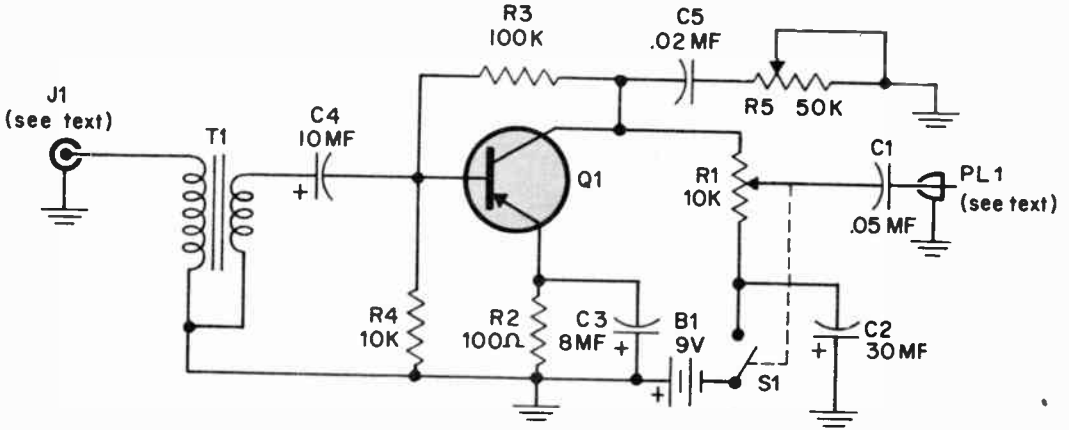

Circuit achieves its frequency characteristic with a fixed bass and a variable treble roll-off.

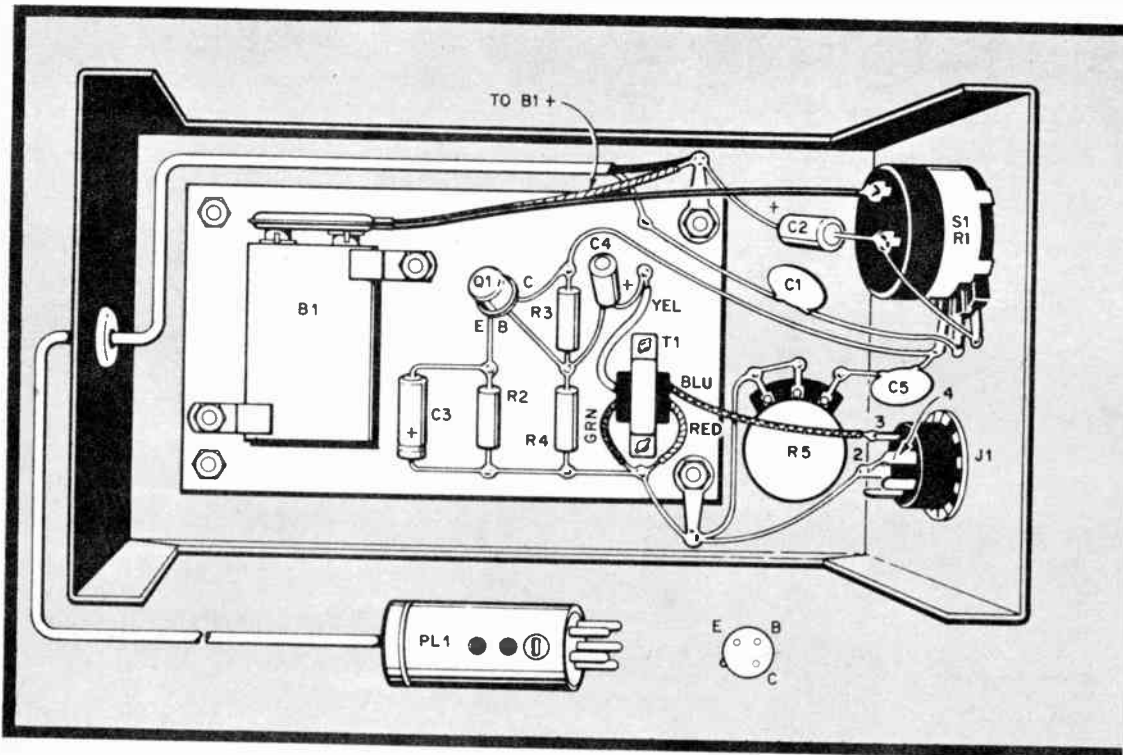

the plug on the microphone cable. Connect T1's blue lead to the J1 terminal which corresponds to the microphone's hot lead. If your mike has push-to-talk switching, run a pair of control wires from J1 through the output cable to PL1. To avoid hum pickup, the P-T-T leads should be outside the shield used for the microphone's hot lead. Do not use an output cable which has all the wires inside a single shield.

Using the Preamp. Plug the mike into J1 and output plug PL1 into the transceiver. Rotate control R5 full counterclockwise (off). Then, speaking in a normal voice, adjust R1 until the transmitter is 100% modulated. Some form of modulation meter (EI's Monitor Meter, CitizenScope, or CB Modulation Meter) is necessary when adjusting R1 since the preamp provides more than enough gain to overmodulate the transmitter. After R1 is set, R5 can be adjusted to give the desired frequency response.

Note that the preamp, is designed for the kind of bass attenuation preferred in communication work. If you desire more bass, use .1 mf for C1.

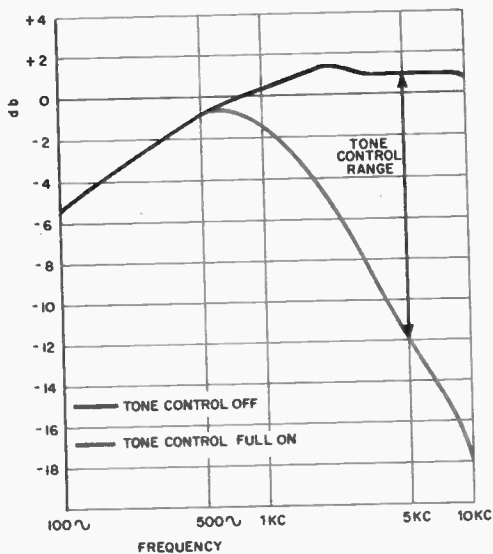

The graph above illustrates the range of tone control available; the exact curve will depend upon the frequency response characteristics of your mike. The bass attenuation is built in.

Circuit is assembled on perforated board before installation on four 1/4" standoffs in the Minibox.

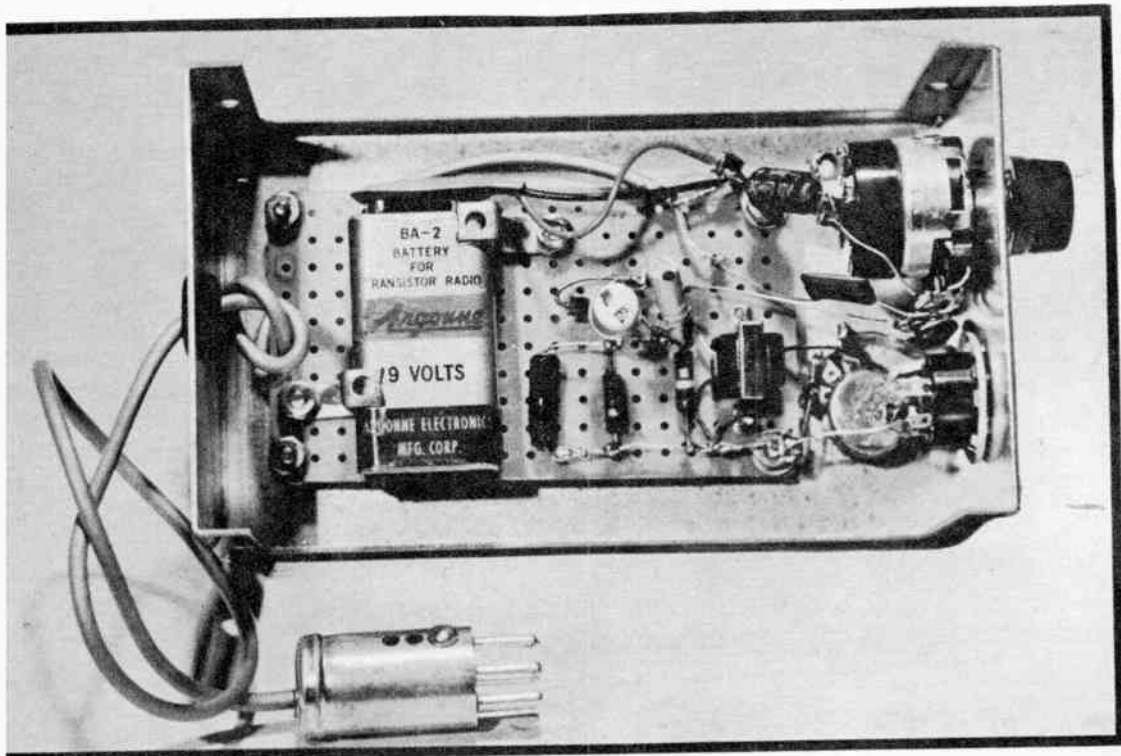

ELECTRONIC WATCH BOX

**Smoke, fire
or intruders will
make this
alarm go off.**

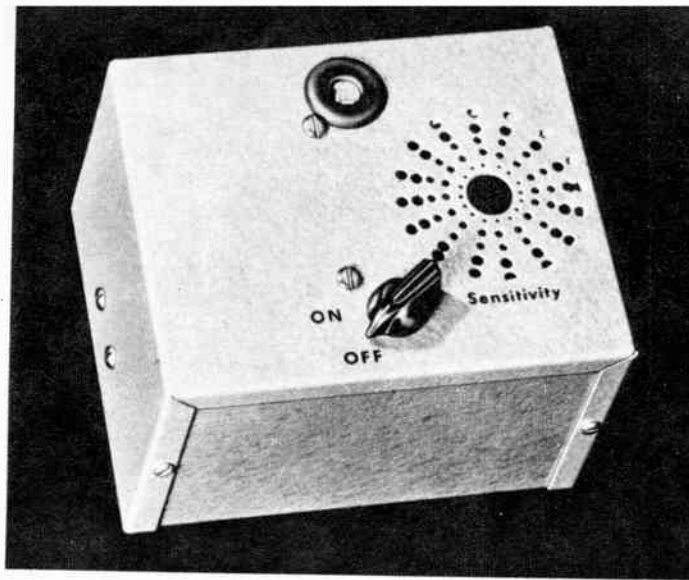

ONE of a watchdog's greatest services to man is to sound off in case of smoke, fires, or intruders. The "Watch-Box" uses a semiconductor to do the same thing, and needs only to be fed a few electrons to keep it going.

The basis of this circuit is the GE-X5 SCR driving a small speaker or earphone in a simple relaxation oscillator circuit, shown in Fig. 1.

Capacitor C1 is charged by current through resistor R1, and is discharged by the SCR into the speaker voice-coil, producing a click or pop sound. The SCR is fired by gate current, derived from the pot R2. As gate bias current increases, a point is reached where the SCR triggers. This point is determined by the setting of potentiometer R2 and the voltage across C1.

If the pot is set for a bias current just below the firing level, a very small increase in current will cause the SCR to fire and discharge C1. The voltage across C1 is then small, therefore the bias current is very low. As C1 recharges, the voltage and gate current rise until the firing level is reached. With a higher current setting of R2, the capacitor is discharged at a lower voltage, producing a faster clicking rate in the speaker.

By inserting a GE-X6 cadmium sulfide photoconductor, PC1, in series with the pot, as shown in Fig. 2, the clicking rate can be made dependent on light falling on the photocell. If R2 is adjusted to a point just below the threshold, a

slight increase in light on PC1 will cause the speaker to start clicking. More light will make the clicking faster and faster. By setting the clicking rate fast enough to produce an audio tone, very small changes in light level are easily and quickly detected.

The cadmium sulfide does not, however, respond well to infrared. By using a cadmium selenide cell, good sensitivity is obtained to the near infrared, such as produced by flames. A lead sulfide cell, although much more expensive, covers the visible spectrum and extends well out into the infrared region, reaching the emission from a hot soldering iron. An inexpensive plastic lens, of one-inch diameter or more, can be used with any of the photoconductors to greatly improve the sensitivity in one direction. The sharper the focusing, however, the more narrow becomes the field of view.

Another method of detecting long-wave infrared, and ambient temperature as well, is to use a high-resistance bead-type thermistor in place of the photoconductor. The thermistor should have a resistance on the order of 100 thousand ohms at room temperature. By carefully mounting the bead at the focal point of a good flashlight reflector, fairly respectable sensitivity to hot objects may be obtained. Since the thermistor is also sensitive to ambient temperature, it also serves to warn of overheating in the room.

This project courtesy of the General Electric Co., Rectifier Components Dept., Auburn, N. Y.

The variable-resistance type humidity sensors can be used, in place of photoconductors, to provide warning of high humidity. To invert this function, that is to sense lowering of humidity, light or temperature, place the sensing element in parallel with the pot R2, and add a fixed 100,000 ohm resistor, R3, where the sensor would normally be, as shown in Fig. 3. For best results, R3 should be made variable.

The Watch-Box may also be used for indication of noise level by connecting a high-output ceramic or crystal microphone from gate to cathode of the SCR, as shown in Fig. 4.

A ceramic contact microphone or phonograph pickup connected in the same place and placed on the floor, or on a wall, will give an indication of vibration, such as footsteps.

To detect smoke, the cadmium sulfide detector of Fig. 2 can be used in an ar-

rangement shown in Fig. 5, on page 65.

The inside surfaces of the chimney, collar, and cup should be painted a flat black, preferably by spray, or may be lined with black velveteen to reduce reflected light to as low a value as possible. Heat from the lamp creates a gentle air flow up the chimney, thus continually moving the room air. Smoke in the air will reflect light from the lamp back into the photoconductor to actuate the Watch-Box. The photoconductor should be shielded from direct light and heat from the lamp.

An alternate method of smoke detection is to use the inverted circuit of Fig. 3 and place the photoconductor at the bottom of the chimney, looking up at the lamp. It will be necessary to place an aperture disc near the lamp, however, in order to reduce light on the cell to a low level, such as in Fig. 6. The smoke in this case will absorb light,

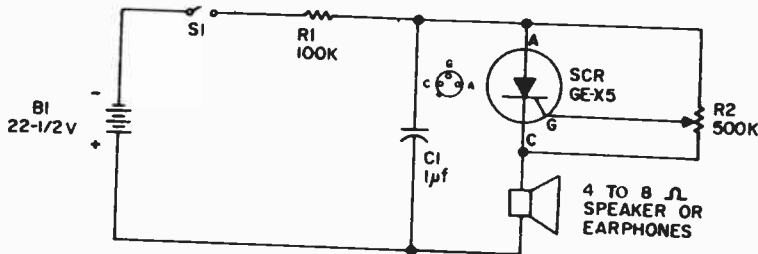
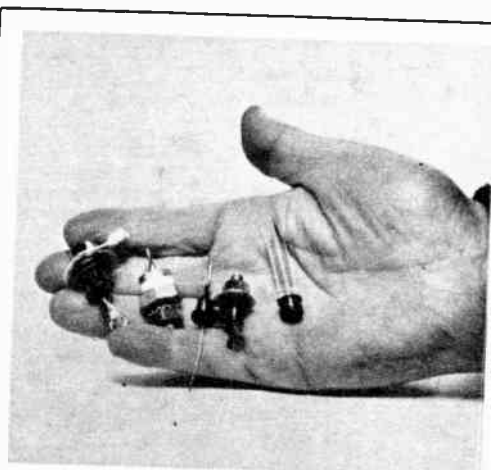

Fig. 1: Basic SCR relaxation oscillator circuit.



A relatively recent addition to the list of electronic abbreviations, "SCR" stands for "silicon controlled rectifier." This solid-state device was developed commercially by Gordon Hall, an engineer with the General Electric Co. It is unusually versatile, and can be used as a lamp dimmer, a motor speed control, a sound generator, a converter of AC to DC and DC to AC, and for many other purposes. A few representative projects of interest to experimenters are given on these pages; others are described in detail in an interesting GE booklet entitled "Silicon Controlled Rectifier Hobby Manual," copies of which are obtainable at radio dealers almost everywhere.

The accompanying photo shows a few sample SCR's sold for hobby applications.

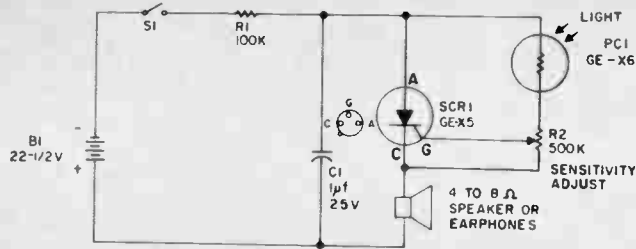

Fig. 2: Schematic of practical light-sensitive alarm.

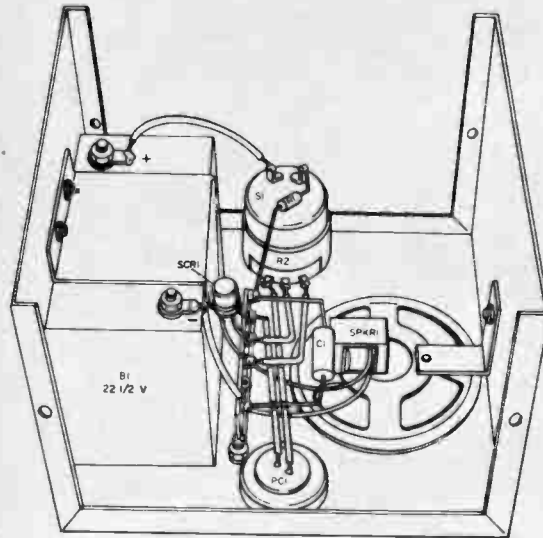

Fig. 2A: Physical layout of schematic diagram, above.

PARTS LIST

C1	— 1 μ f, 25 volt (minimum) capacitor
PC1	— GE-X6 cadmium sulfide photoconductor
R1	— 100,000 ohm resistor
R2	— 500,000 ohm potentiometer
S1	— SPST switch (on R2)
SCR1	— GE-X5 Silicon Controlled Rectifier
SPKR1	— 4 to 8 ohm speaker
B1	— 22 1/2 volt battery

thus raising resistance of the photoconductor.

For multiple input signals in one unit, diodes may be used for proper mixing, Fig. 7.

You can build your Watch-Box just as simple or as complex as you desire. The circuit of Fig. 2 can be built in a little plastic case with PC1 exposed, and used as a portable fire alarm in your

bedroom or hotel room. If you leave the blinds open slightly, the little gem will awaken you in the early dawn.

For greater peace-of-mind when using an intercom as a baby-sitter, the full complement of light, smoke, heat, sound, and humidity detectors can be employed. Just place the Watch-Box speaker near the intercom, or run out separate wires for a remote speaker.

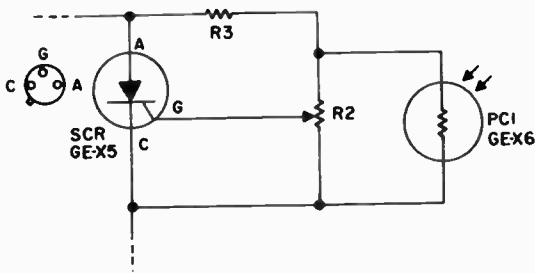

Fig. 3: Reversed-mode connection for light-sensitive oscillator.

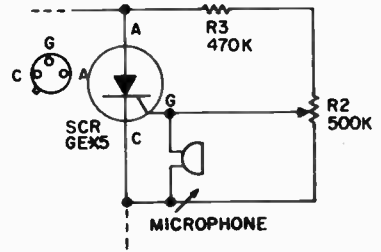

Fig. 4: Sound or vibration-sensitive control for oscillator.

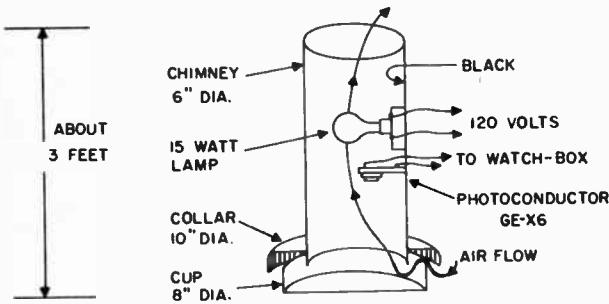

Fig. 5: Cross-section view of smoke detector.

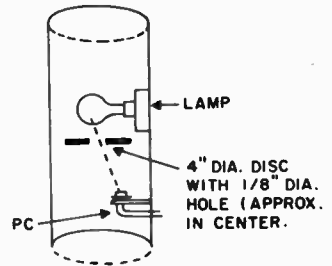

Fig. 6: Alternate arrangement for smoke detector.

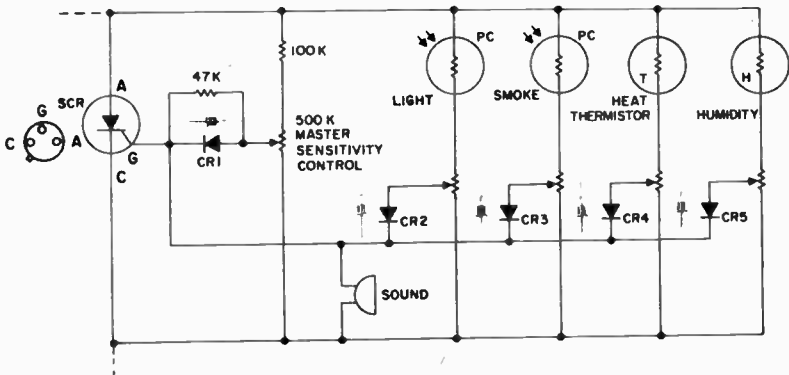

Fig. 7: Multiple input circuit.

Should an input signal get so high that the system hangs up, a push-button switch to momentarily short out the SCR should bring it back into operation. In normal operation, the SCR is commutated (turned off) by the tendency of the capacitor, C1, and inductance of the speaker coil to oscillate. A large drive on the SCR gate can cause it to fail to commutate and thus hang up.

The push-button switch is also handy to check out the system to be sure it is ready to operate.

You may want to try some of the hundreds of other variations of these circuits, such as replacing the pulse developed across the speaker to drive a larger SCR and so control lamps, larger relays, motors, fans, etc.

SCR

Controls Speed of Railroad

Box gives full and fine control over movement of model trains.

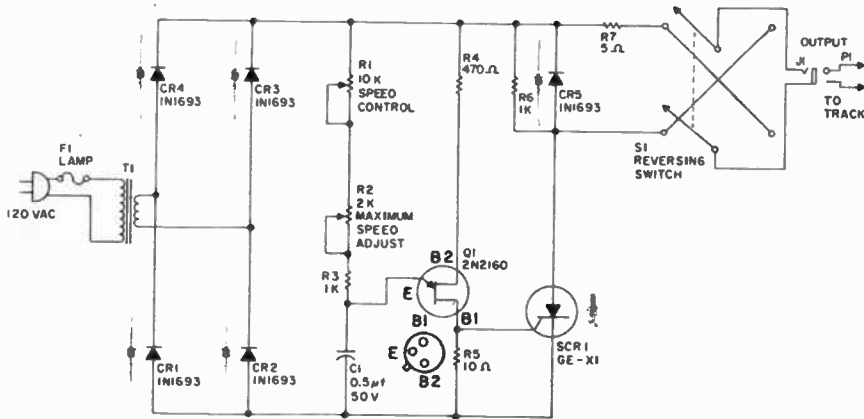
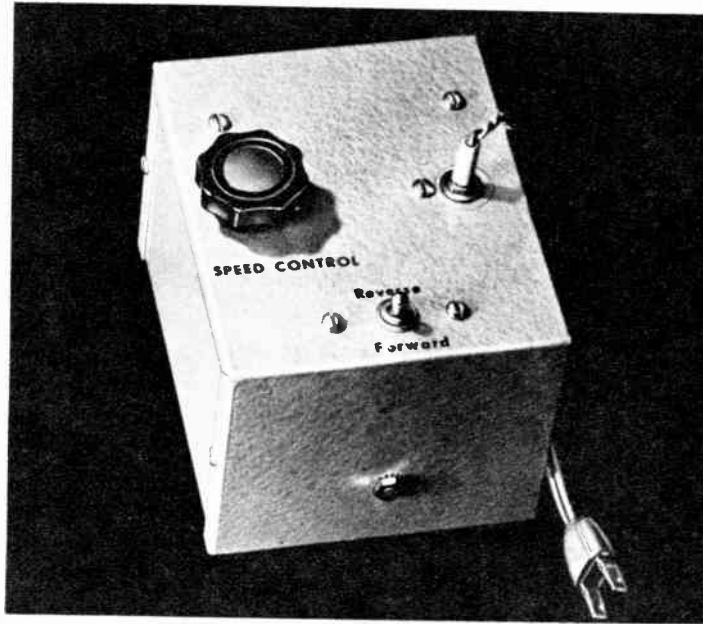

Fig. 1: Complete schematic of model railroad speed control.

SERIOUS model railroaders have been continuously plagued with problems of staggering magnitude from the earliest days of the development of this fine art.

The control of a train which the hobbyist could not sit on (without crushing) was nearly impossible before the advent of electronics. When electric

trains appeared, a new and fascinating era had begun. The control of the train became simple, if not realistic, but scale speeds were difficult to obtain accurately and smoothly. Starting and stopping were really headaches. The truly serious hobbyist cringed at the thought of turning up that rough, hot dial and watching his scale-tons of steel jounce

This project courtesy of the General Electric Co., Rectifier Components Dept., Auburn, N. Y.

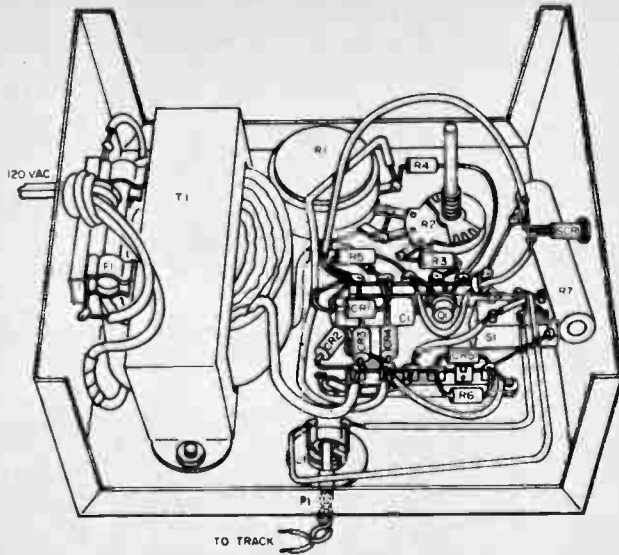

Fig. 2: Positions of parts are not critical, but this is a good layout to follow, with all parts clearly marked.

PARTS LIST

- C1 — 0.5 μ f, 50 volt capacitor
 - CR1, CR2, CR3, CR4, CR5 — G-E Type 1N1693 rectifier diode
 - F1 — $\frac{1}{2}$ amp fuse
 - J1 — Output jack
 - P1 — Output plug to track connections
 - Q1 — G-E Type 2N2160 unijunction transistor
 - R1 — 10,000 ohm, 2 watt potentiometer
 - R2 — 2000 ohm, 2 watt potentiometer
 - R3, R6 — 1,000 ohm, $\frac{1}{2}$ watt resistor
 - R4 — 470 ohm, $\frac{1}{2}$ watt resistor
 - R5 — 10 ohm, $\frac{1}{2}$ watt resistor
 - R7 — 5 ohm, 20 watt resistor or two 10 ohm, 10 watt resistors in parallel
 - S1 — DPDT switch
 - SCR1 — GE-X1 Silicon Controlled Rectifier
 - T1 — Transformer: primary, 120 volts AC, secondary, 25 volts AC (Stancor P-6469, or equivalent)
- All resistors 10% tolerance

up to a scale speed of several hundred miles per hour.

Then appeared the SCR, and another era had begun. Model trains could be controlled simply and inexpensively.

The secret of SCR's success is the ability to apply power to the engine in pulses, and to control the width of these pulses. Correct scale speeds are prac-

tical, and ultrasmooth starting and stopping are no longer an unattainable fantasy.

The bridge (CR1 - CR4) supplies pulsating DC to the firing circuit (Q1, R1-R5, C1) which phase controls the SCR. The SCR is in series with the train power and thereby controls the amount of current it receives.

Applying Heat WITH PRECISION

A single knob sets heat at desired level.

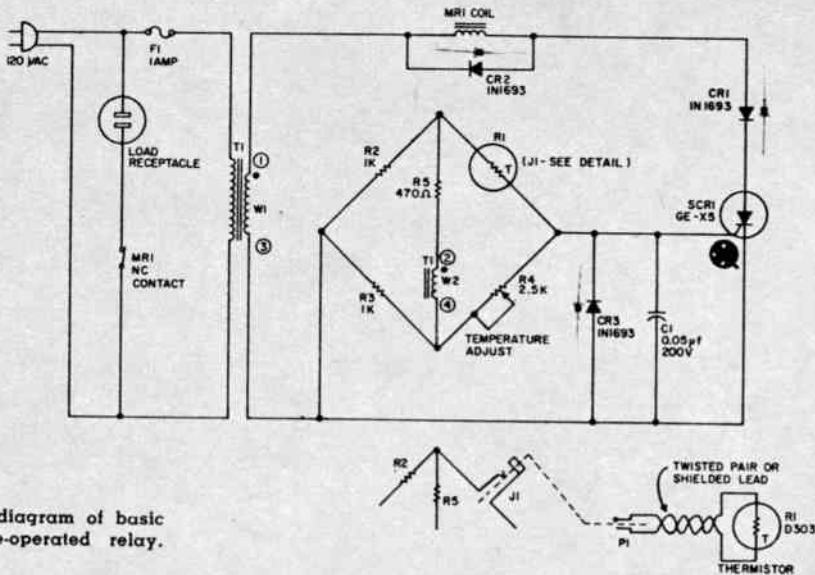
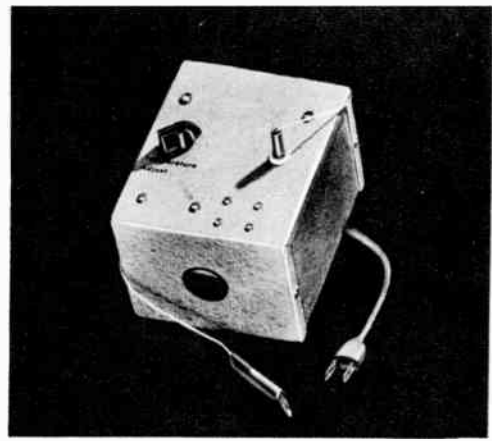

Fig. 1: A diagram of basic temperature-operated relay.

WITH the turn of a knob you can bring your soldering iron up to the temperature you want and keep it there. Or perhaps you want a tub of tepid water, or to turn on a fan when the room gets too hot, or to turn on the furnace when it gets too cold. These things plus innumerable others are possible with simple SCR temperature-controlled circuits.

The basic temperature operated relay is detailed in Fig. 1. Transformer T1 has two 12.6 volt secondary windings, W1 furnishing voltage to the relay MR1 through SCR1, the other winding W2 furnishing AC voltage to the trigger circuit of SCR1. Temperature sensing thermistor R1 is electrically connected into a bridge formed by it and R2, R3,

PARTS LIST

- C1 — 0.05 μ f, 200 volt capacitor
- CR1, CR2, CR3 — G-E Type 1N1693 rectifier diode
- F1 — 1 amp fuse
- J1 — Temperature probe jack
- MR1 — Relay, DPDT 5 amp contacts with 6 volt DC GPD coil (Potter & Brumfield GP11, or equivalent)
- P1 — Temperature probe plug
- R1 — G-E Type D303 thermistor, 0.3 inch dia., 1000 ohm at approximately 170°F
- R2, R3 — 1000 ohm, 2 watt resistor
- R4 — 2,500 ohm, 4 watt wire wound potentiometer
- R5 — 47 ohm, 2 watt resistor
- SCR1 — GE-X5 Silicon Controlled Rectifier
- T1 — Transformer: primary, 120 volts AC; secondary, W1 12.6 volts and W2 12.6 volts (UTC-FT10, or equivalent)

This project courtesy of the General Electric Co., Rectifier Components Dept., Auburn, N. Y.

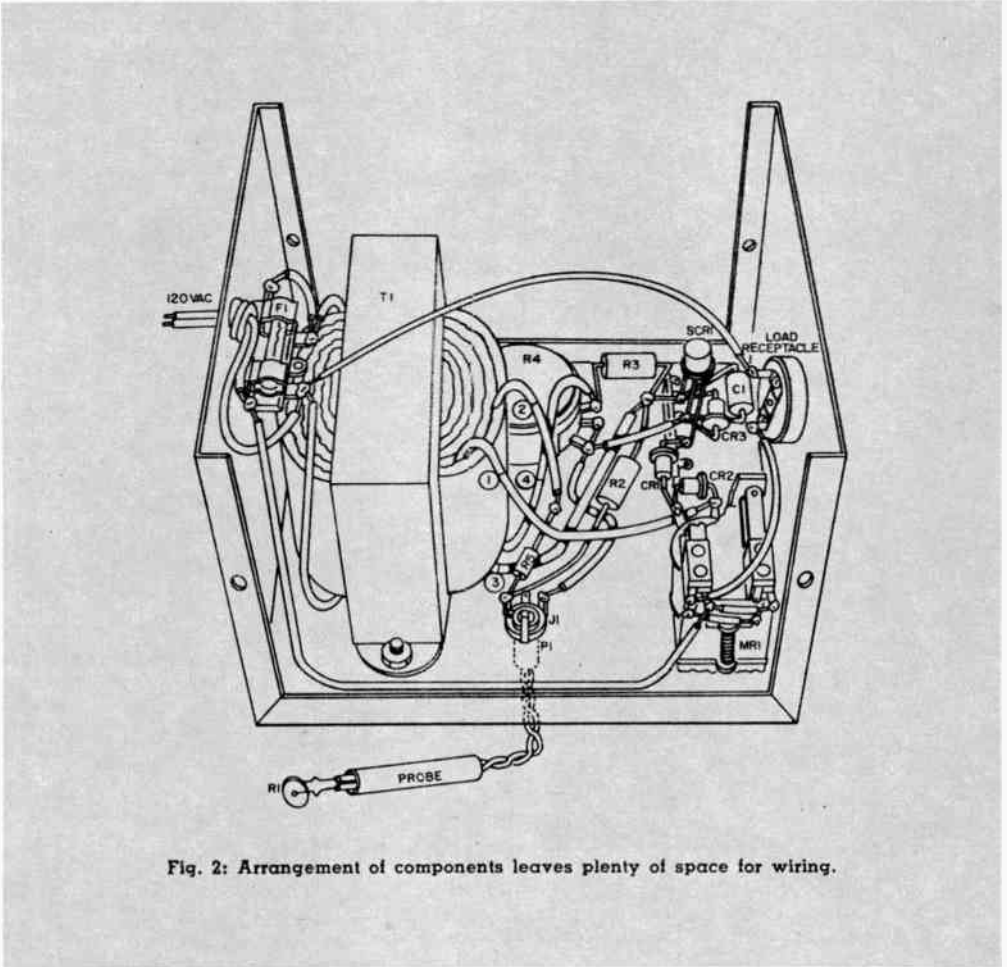

Fig. 2: Arrangement of components leaves plenty of space for wiring.

and adjusting potentiometer R4. When the resistance of thermistor R1 equals the resistance setting on R4, the bridge is balanced and none of the AC voltage introduced into the bridge by winding W2 is applied to the gate of SCR1. Hence, relay MR1 remains de-energized and its normally closed contacts apply power to the heating elements connected to the load receptacle. If temperature increases, the resistance of thermistor R1 decreases, unbalancing the bridge in a direction such that trigger current flows to SCR1 while its anode is positive. This turns on SCR1 and energizes the relay, thereby disconnecting power from the connected load. Below the preset temperature setting, R1 unbalances the bridge in the opposite direction so a

negative signal is applied to the gate of SCR1 when its anode is positive, thus inhibiting it from firing and allowing power to continue to flow to the heating elements.

Locating the thermistor on the soldering iron, in the bath water or in any other zone that must be temperature controlled will provide the necessary feedback information. If the thermistor is to control a cooling system such as a fan or air conditioner rather than a heating system, opposite action can be secured by either connecting the load to a normally open contact on the relay or by reversing the leads on the secondary winding W2.

This circuit will control the temperature at thermistor R1 within approxi-

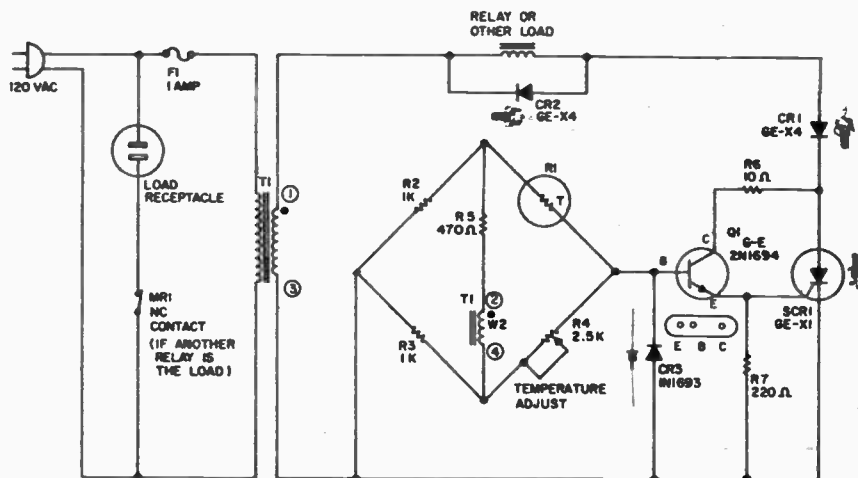

Fig. 3: Temperature-operated control for higher current loads.

PARTS LIST

CR1, CR2	—GE-X4 rectifier diode
Q1	—G-E Type 2N1694 transistor
R6	—10 ohm, 2 watt resistor
R7	—220 ohm, 2 watt resistor
SCR1	—GE-X1 Silicon Controlled Rectifier

mately one degree over the temperature range from 20°F. to 150°F. For most precise temperature control in this and other ranges, SCR1 should be kept at a relatively stable ambient temperature. For other temperature ranges, thermistor R1 should have approximately 1000 ohms resistance in the center of the desired control range.

SCR1 is rated to handle ½ ampere maximum and the contacts of relay MR1

are rated for 5 amperes at 120 volts AC. Heavier loads can be handled by using MR1 as a pilot relay to pick up a larger contactor. Alternately, 6 volt coils or other loads requiring currents of several amperes can be directly controlled by SCR1 if a larger device than the GE-X5 is used. For instance, the GE-X1 can control at least 4 amperes directly if adequately cooled. However, since its gate triggering sensitivity is inadequate for the previous circuit, a stage of transistor amplification is necessary as shown in Fig. 3. Two separate single-secondary transformers can be substituted for T1.

Other types of sensing resistors can be substituted for R1. For instance, a cadmium sulfide light sensitive photoconductor in this control will turn on a lighting load when the ambient light drops below a preset level. ●

PHOTOCONDUCTOR PROJECTS

for the Experimenter

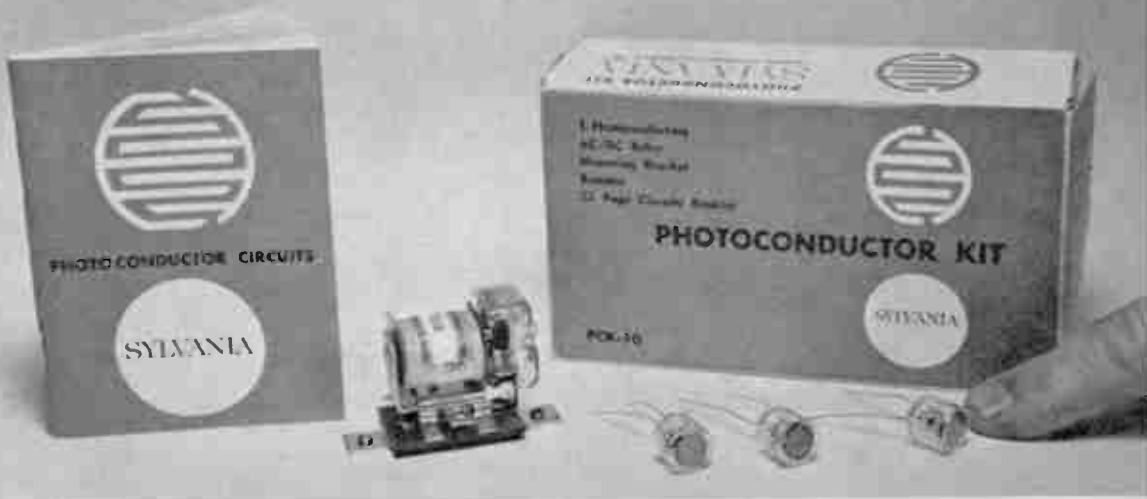

This kit includes three photoconductors, relay, and fixed resistor. The cells are less than thumb-size.

ELECTRONIC experimenters are generally familiar with photoelectric cells, but seem to be confused about *photoconductor* devices. They are quite different in both theory of operation and practical application.

A photoelectric cell generates a weak electric current when light falls on its surface. This is just about enough to register on a very sensitive ammeter for the measurement of light intensity, for example, for photographic purposes. For many other purposes, however, the low output of the cell must be amplified by vacuum tubes or transistors. A photoconductor, on the other hand, acts as a variable resistor whose ohmic value depends on the light falling on its face. In darkness, the resistance is in the order of millions of ohms, a virtual open circuit, while under the stimulation of light the value may be under 10 ohms.

The big advantage of the photocon-

ductor is its ability to control comparatively large amounts of energy *directly*, without the need for complicated amplifiers. If such a cell is connected in either series or parallel with a source of AC or DC, as shown in Fig. 1, it acts as a sensitive switch for a simple relay. In darkness, with its resistance high and the current through the relay therefore negligible, the relay remains dead. When enough light hits the cell, the current rises and the relay can be arranged so that the controlled circuit is normally open or normally closed, or two different circuits can be hooked in to operate "on" and "off" alternately.

Photoconductors are very interesting and versatile devices and lend themselves admirably to numerous electronic projects. Photo shows a convenient kit of three such cells of the cadmium sulfide type, including a relay for the control of 117-volt appliances. This is

marketed by Sylvania Electric Products, Inc., 1025 Westminister Drive, Williamsport, Pa.

The Sylvania-type T-4 photoconductors found in this kit are only a half inch in diameter and a half inch high, but they can safely dissipate 300 milliwatts (about $\frac{1}{3}$ watt). This is more than enough to actuate a variety of relays.

A simple use for photoconductors is shown in Fig. 2. This might be described as an annunciator or burglar alarm. The photoconductor and the small 7-watt lamp can be mounted on opposite sides of a door or window frame, in tubular shields of some kind so that only the light of the lamp impinges on the face of the photoconductor. With the latter so energized, its resistance is low and current flows through the relay winding to hold the armature against the open contact marked NO. The buzzer, bell, lamp or other alarm connected through the armature to the AC line therefore is not activated. Now, if a person walks through the door and thus interrupts the light beam, even for a moment, the resistance of the photoconductor jumps, the current to the relay falls, the armature contact returns to the NC or normally closed position, and the alarm is activated. It is quite simple, of course, to add a latching relay to the alarm circuit so that the latter stays on until it is released manually.

Note the simplicity of the circuit: the light source, the photoconductor and the relay connect directly to the AC line.

A variation of this arrangement suggests itself immediately for garage door control. The photoconductor can be mounted at headlight height at the edge of the door, in a tube or pipe aimed so that it receives bright light only from the headlights. The relay contacts then close only when the photoconductor is energized by the latter, and they operate the opener. A latching relay is normally part of the motor mechanism, and this shuts the motor off when the door reaches its top position. Since the photoconductor draws virtually no current from the AC line in its "dark" condition, it can be left in the 117-volt circuit permanently.

Fig. 1. Basic photoconductor circuits. In A, "dark" resistance of device is high, no current flows through the relay, the latter is dead, and the relay armature is at the NC (normally closed) position. In B, the "dark" resistance, being high, permits current from the AC or DC source to flow through relay, actuating the armature and causing the external load circuit to close. When light hits the photoconductor in the shunt circuit, the resistance falls so low that in effect it short circuits the relay winding; the armature loses its pull and load circuit opens.

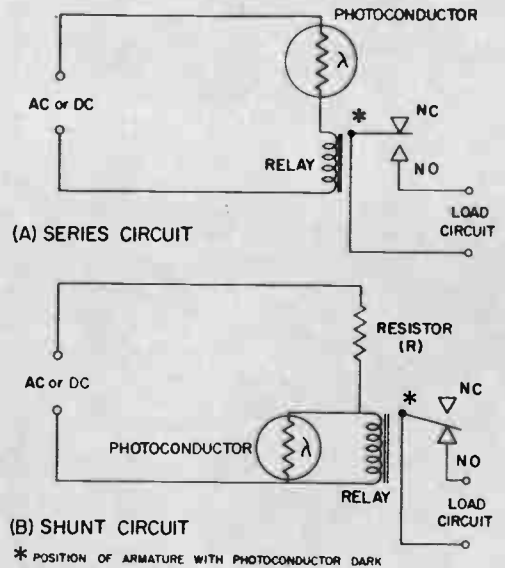
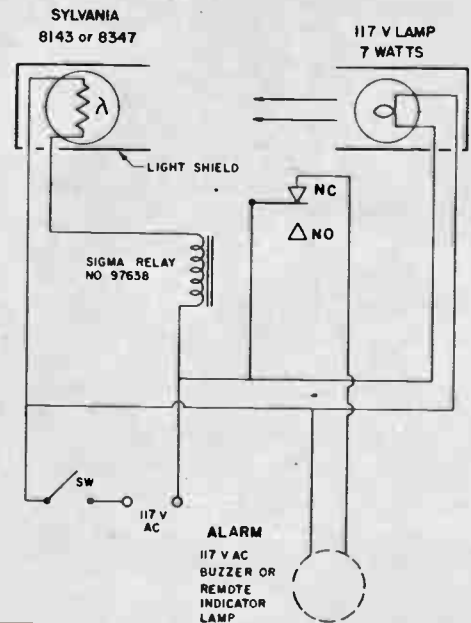

Fig. 2. A schematic of the burglar alarm, using a small 7-watt light source and photoconductor.



TARGET SHOOT FOR GAME ROOM

The circuit of Fig. 1 is a simple "Target Shoot" that can be constructed out of readily available materials. The bull's-eye is a Sylvania photoconductor mounted on a stationary or swinging target about a foot in diameter. The cell is connected via the relay to the hit indicator, which can be a red light or an ordinary bell or buzzer with a suitable resistor connected in series to reduce the line voltage to about 10 volts.

The "bullet" is a ray of light from an ordinary flashlight mounted on a piece of wood cut to resemble a rifle stock. The sharper the light beam, the greater the required shooting accuracy. A standard microswitch is an excellent "trigger," or one can be improvised from a few pieces of brass.

To prevent the photoconductor from being actuated by the regular lights in the room, mount it behind the target board, inside a small juice can.

This target shoot is always good for a lot of fun, for both adults and children alike.

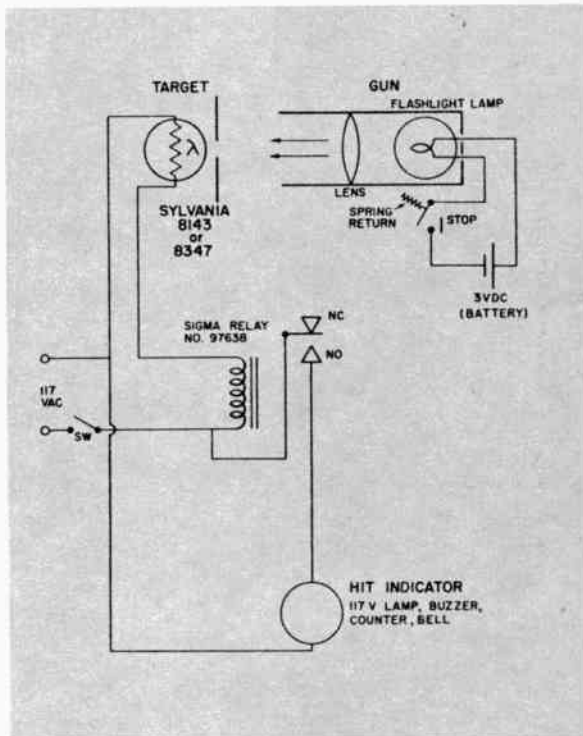

MODEL RAILROAD CROSSING GUARD

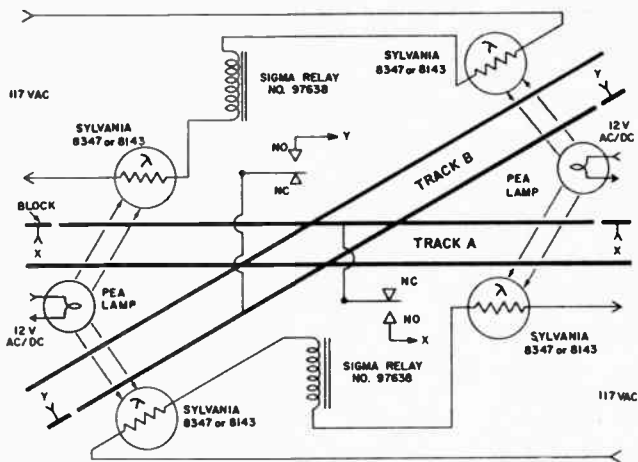

Owners of model railroads will find this a novel addition to their layouts. As shown in Fig. 2, four photoconductors and two relays are required.

As long as the beams from the exciter lamps are unbroken, the relays are energized and power is provided to the blocks via the normally closed contacts. A train approaching the crossing at one track will open the power circuit to the

blocks of the other tracks. (See above.)

The photoconductors and the pea lamps should be positioned at an angle to the cars so that the gap between cars will not affect circuit operation. This can be accomplished by mounting the lamps overhead in a signal bridge and placing the photoconductors underneath the tracks a few inches on either side of the bridge.

MASTER TV/FM ANTENNA SYSTEM

By Lon Cantor

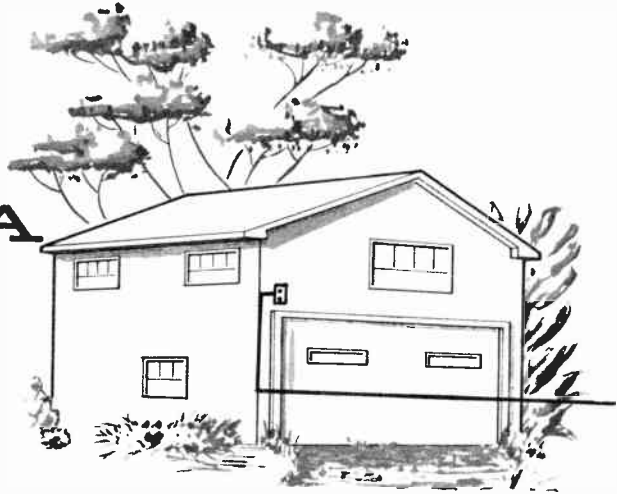

IN a day and age when most homes have two or more TV sets, the problem of what to do about antennas can get pretty messy—at least if you want top-notch results. True, many people own portable TV's which they can move from room to room. And in areas where the "rabbit ears" type of indoor antenna works well enough, such sets can get by. Other TV sets rely on their own built-in antennas. However, in all but the best signal areas, rabbit ears and built-in antennas give you an inferior picture, if any picture at all.

To get maximum enjoyment from all your TV sets, you need a good outdoor antenna. After all, a TV set has but one thing to work with, and that's the signals its antenna supplies. Give it a poor antenna, and it'll more than likely give you a poor picture. But lend it a first-class antenna, and you'll be delighted with the results.

Same thing applies to an FM set. Rely on the set's built-in antenna or a little folded dipole tucked under the rug, and you'll miss a good many stations you might otherwise pick up. And you'll get less than maximum quieting all the way across the band.

Since it's both impractical and needlessly expensive to install separate antennas for every TV or FM set you own, why not make a single antenna serve all of your sets? Our master TV/FM

antenna system, shown in the drawing, uses a single, multi-channel TV antenna and can serve as many as four sets anywhere in the house.

Matter of fact, we've shown an extension into the garage just in case you'd like to watch your favorite show while fiddling with the car. Understandably, we've pictured a garage only for purposes of illustration: the fourth lead from the box in the drawing could go into yet another room in the house. Or it might feed an outlet in the patio.

As some tinkerers have discovered, it's impossible to hook up more than one TV or FM set to a single antenna and still get good results—unless you know how. Since most antennas and TV and FM sets have a characteristic impedance of 300 ohms, hooking up more than one set to the antenna will upset the impedance match.

For example, if you connect two sets in parallel, the antenna will see only 150 ohms instead of the 300 ohms it's supposed to. Similarly, connect two sets in series, and you'll force your antenna to look into 600 ohms. In either case, a serious mismatch occurs, and precious energy will be lost.

Even more important, standing waves likely will cause some of the signal to bounce up and down on the transmission line like a yo-yo, resulting in ghosts on the TV screen. Then, too, since every

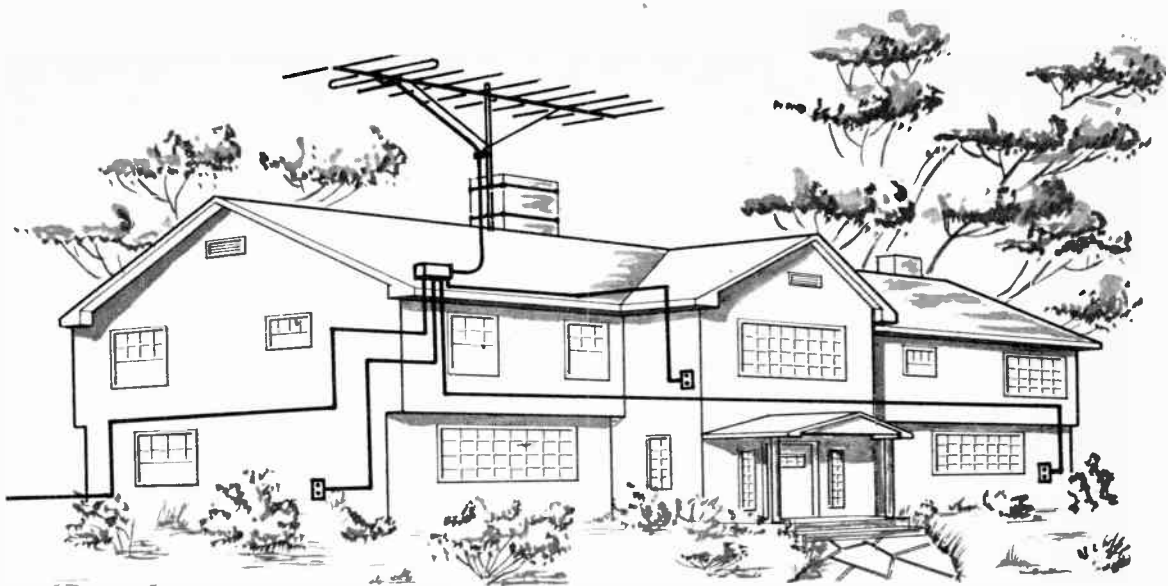

TV and FM set has its own local oscillator, inter-set interference may result unless the sets are isolated adequately.

The simplest type of distribution system uses a two- or a four-set coupler. The coupler will perform the required functions of impedance matching and receiver isolation and thus enable you to use one antenna for from two to four sets. The lines which you see in red on the drawing represent standard 300-ohm TV twinlead and can be connected to an outlet box for each TV or FM set.

Coaxial cable is another possibility for feeding the signal between coupler and sets. Though it's more expensive than twinlead, it also picks up much less man-made interference. This is especially important in cities where auto ignition and diathermy machines can be real nuisances.

If you do decide to use coax, such as RG-11/U, the impedance problem again presents itself. Both the antenna and the various sets are 300-ohm devices, while the coax itself has an impedance of 75 ohms. However, there are suitable matching transformers—the Miller 6162 is one—on the market which will do the trick very nicely. You'll need one at the output of the coupler to step the impedance down from 300 to 75 ohms, and you'll need another at every set to step it back up to 300 ohms.

In areas with very strong signals, the

300-ohm twinlead between the matching transformer and the set itself must be kept as short as possible to prevent direct signal pickup. For this reason, it's generally best to mount the matching transformer right on the back of the set.

Now that we have the basic system firmly in mind, let's consider some of the other possibilities for a home TV/FM antenna system. In the installation just described, we've assumed that a single broadband TV antenna will be used, and that its performance will be adequate for all TV channels and FM as well. But this is a lot to expect from any one antenna, especially if the antenna has to be beamed in one direction for most stations and you're desirous of picking up a weak station on channel 5.

Actually, there's no reason why you can't install two or more antennas, each designed to cover a specific band or channel. If channels 2, 4, 7 and 9 happen to be the ones you watch most, it's entirely possible to mount four single-channel antennas on your roof, rather than one broadband array. Each antenna then can be beamed in the direction of the station you wish to pick up, and the outputs of the four antennas can be fed into a four-set coupler, connected in reverse (see drawing on top of the next page).

Similarly, by using a two-set coupler, again connected in reverse, you can

MASTER TV/FM ANTENNA SYSTEM

hook up a high-band antenna—one that picks up channels 7 through 13—and a low-band antenna, covering channels 2 through 6, to a single feed line. In this case, it again would be possible to beam both antennas for optimum signal pick-up of their respective channels, rather than be stuck with the compromise type of arrangement that a single broadband antenna necessitates.

In the event that you're trying to receive one particular channel and already own a broadband antenna, you might decide to purchase a single-channel antenna and hook it up to a two-set coupler as shown in our drawing. Because the single-channel antenna is cut for that specific channel, it should be much more efficient than the broadband array. Further, as in the case of the high-band and low-band antenna installation, you can aim the single-channel antenna directly at the station you wish to receive.

For listeners in fringe areas where getting any kind of decent image is rare as picture tubes in a trash can, there's another trick to hooking up any of these multi-set or multi-antenna systems. Though today's TV receivers vary widely in sensitivity, most require on the order of 300 to 500 uv. of picture carrier signal per channel. If your

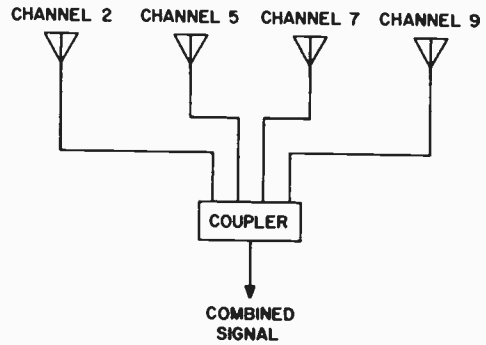

Separate, single-channel antennas beamed toward stations give best signals. Drawing shows channels 2, 5, 7 and 9, but any four channels can be included.

home is close to the transmitter, it's not unusual for your antenna to pick up 300,000 uv. of picture carrier. But let's suppose you live 30 miles away from the transmitters. You might pick up only 500 or 600 uv. of signal—enough for one TV set, perhaps, but hardly enough for four.

The answer in this case is either to use a high-gain antenna or, better yet, install a signal booster. Though it's a fairly inexpensive little gadget, a booster is actually a kind of RF amplifier which steps up the signal as it comes from the antenna.

Booster gain is expressed in decibels (db) and, for the record, a booster with a gain of 6 db will double the signal voltage, while one with a gain of 20 db will increase the signal tenfold. If you're in doubt about what kind of gain to expect from a booster, reference to a voltage/decibel conversion chart should clear up the problem.

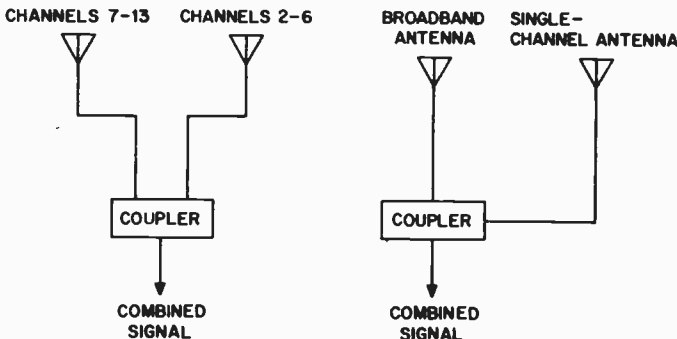

Good reception of all 13 TV channels often requires separate antennas for specific frequencies. For lowest losses, the two antennas should feed into a coupler.

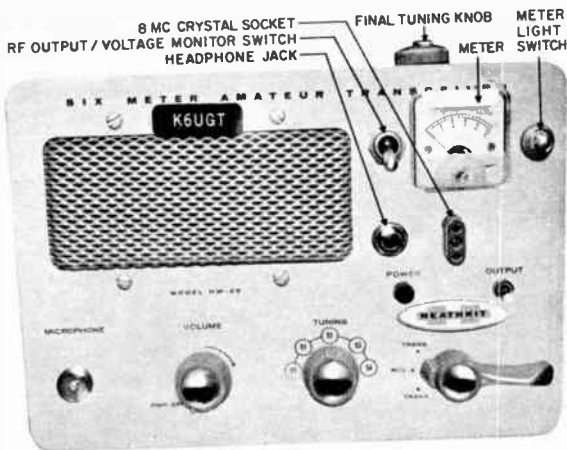

Fig. 1—Callouts point to additions to Model HW-29 Sixer. Meter-light switch turns on lamps in meter. Holders for 8-mc crystals can be added on left side of the cabinet.

Deluxe your HEATH SIXER

By Fred Blechman, K6UGT

THE Heath Sixer, a popular, top-performing 6-meter transceiver, can be given added versatility with a few simple modifications that cost only about \$8. The dress-up will provide bandspread, an RF output/power-supply-voltage meter, a headphone jack, a convenient way to tune the final and a change that enables you to use inexpensive 8-mc crystals instead of the more costly fifth-overtone type.

• **Bandspread.** Since almost all activity is on the first two megacycles (50-52 mc) of the 6-meter band, which extends from 50-54 mc, bandspread will eliminate coverage of the dead upper half of the band. The modification requires a capacitor be installed (C1, Figs. 2 and 5) in series with the existing tuning capacitor (C108 in the HW-29, C18 in the HW-29A). By using a 10-mmf capacitor for C1 you can reduce the receiver tuning range to about 1.7 mc, anywhere in the band. This effectively doubles the area that a selected portion of the band will occupy on the dial. Station tuning will now be less critical. If you don't want to spread the band out that much on the dial, use a 15-mmf capacitor for C1. For more bandspread, use a 7-mmf capacitor. Install C1 as shown in Fig. 5 between C108 (C18 in the HW-29A) and detector coil L102 (L5 in the HW-29A). Readjust the slug of L102 so 51 mc falls at about the 52.3-mc mark on the dial. If C1 is 10 mmf, the receiver

tuning range will now be about 50.1-51.7 mc. The original dial readings will no longer be correct, but this won't take long to get used to.

• **8-mc Crystals are Cheaper.** The Model HW-29 uses expensive fifth-overtone crystals in a sometimes unstable oscillator circuit. (The HW-29A has an additional tube and uses 8-mc crystals.) Eight-mc crystals can be purchased for as little as fifty cents each. To modify the HW-29, disconnect the four wires attached to oscillator coil L201. Remove the coil from the chassis and unwind all the wire from the form. Evenly wind 29 turns of #22 enameled wire in the same space of the coil form, scrape the enamel from the ends of the wire then solder to the lugs. Replace L201 and solder the four wires to the lugs they were on before.

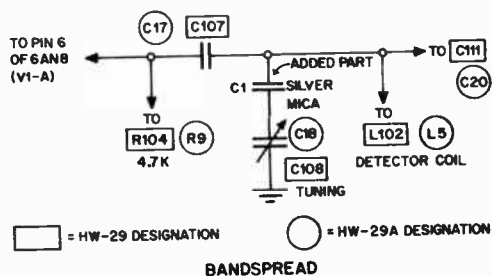

Fig. 2—A 10-mmf capacitor in series with tuning capacitor spreads half the band over entire dial.

Deluxe your HEATH SIXER

Install the crystal socket on the front panel as shown in Fig. 1. Solder #16 wire, covered with spaghetti, to the lugs on the new socket and force them in the contacts in the old crystal socket. Do not use coax or twisted-pair between the two sockets. The 8-mc crystal frequency should be one sixth the desired transmitting frequency. For example to transmit on 51 mc, use an 8,500-kc crystal. To tune up the final, plug a dummy load (#47 pilot lamp) in the antenna jack and turn on the power. Set the mode switch to transmit, and using a plastic alignment tool, adjust the slug of L201 for maximum lamp brilliance. Then detune slightly for stability. Adjust the final tuning slug in L202 for

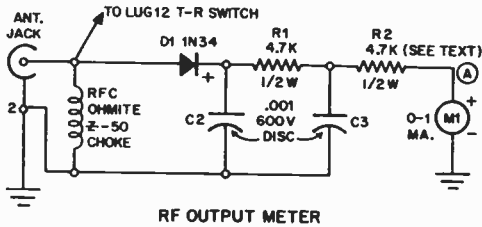

Fig. 3—RF-output-meter circuit is shown above. Be sure of the polarity of D1 before installing.

maximum brilliance of the pilot lamp.

Ideally, the slug of L201 should be in the center of the coil form. If it is too low, remove a few turns from L201 and retune. If it is too high, rewind the coil with a few more turns of wire and retune. A grid-dip meter tuned to three times the crystal frequency will indicate the correct slug position when the coil is installed and the transmitter is operating.

The 8-mc crystal oscillates on its third overtone. The output of the oscillator is then doubled in the final to produce the 50-mc output. However, some tripling may occur in the final which may interfere with TV reception on channel 5. A good low-pass filter designed to cut off above 52 mc, installed on the

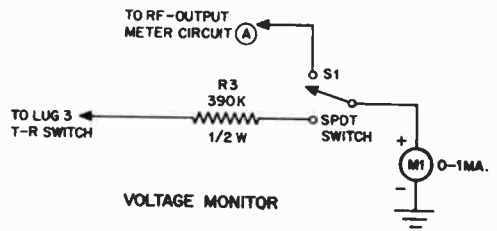

Fig. 4—Power-supply voltage-monitoring circuit requires S1 be added to the circuit in Fig. 3.

back of the Sixer, will suppress such interference.

• **RF Output Meter.** The plate current dip in the Sixer is difficult to determine. A much more accurate tune-up can be achieved by using a meter that reads RF voltage. Mount the meter on the front panel as shown in Fig. 1. The circuit is shown in Fig. 3 and the installation of the rectifier-filter network (already built in the HW-29A) is shown in Fig. 8.

The value of R2 is determined by the sensitivity and internal resistance of the meter, the efficiency of D1, power output of the transmitter and the standing wave at the metering point. If the

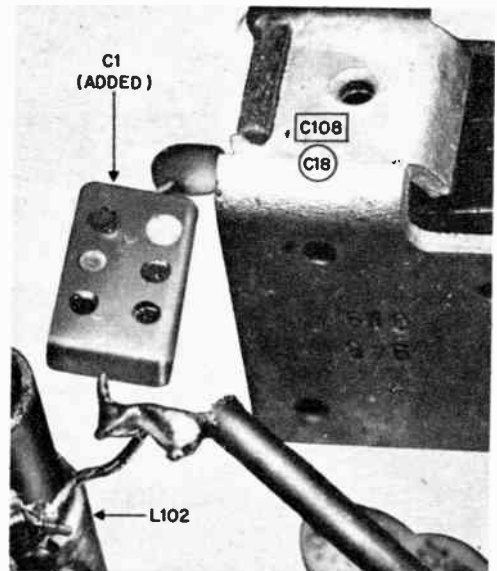

Fig. 5—Bandspread modification. Leads formerly going to C108 (C18 in HW-29A) are connected to one side of C1. Other side of C1 goes to C108.

meter pins, use a higher-value resistor for R2. If the indication is too low, decrease the resistance of R2. Do not use a meter less sensitive than 0-1 ma. as it will reduce transmitter output power.

Since the meter measures RF voltage at a particular point on the transmission line it is subject to the effect of the standing wave at that point. The meter

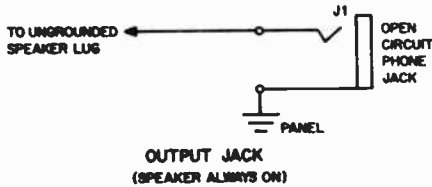

Fig. 6—The Sixer speaker will always be on if you use this circuit to add a jack for headphones.

therefore, is to be used only to indicate a maximum point when tuning and not for qualitative measurements.

• **Power-Supply Voltage Monitoring.** Since power-supply voltage is an important indication of proper operation, add a switch and resistor (Fig. 4) to the previously installed circuit to monitor power-supply voltage in both the transmit and receive modes. The actual voltage is not really important, but a radical voltage change is a clue to trouble. Normally S1 is left in the voltage-monitor position. For tune-up, set S1 to the RF output position.

• **Tuning the Final (HW-29 only).** Now that you have a front-panel RF meter and crystal, it will be a cinch to tune for maximum output with each crystal you use. Just drill a hole in the cabinet above final coil L202 and tune for maximum output on the RF

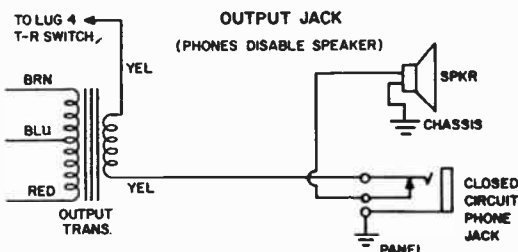

Fig. 7—Use this circuit and the headphones will automatically turn off speaker when plugged in.

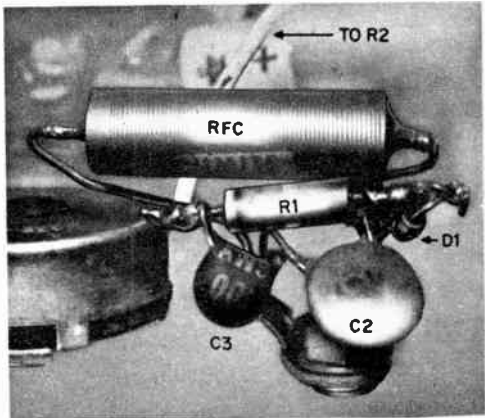

Fig. 8—RF-output-meter parts are located on rear chassis apron near regeneration control R106 (left). Don't apply excessive heat when soldering to D1.

output meter with a plastic alignment tool left in position permanently. Since the slug of oscillator coil L201 can be adjusted for a broad range, tune it to a spot which covers the crystals you plan to use the most and touch-up only the final tuning when you change crystals.

• **Universal Fusing.** The Sixer requires an 8-amp fuse for mobile operation but only a 1.5-amp fuse for AC-line operation. If you use the Sixer both fixed and mobile, you may forget to install an 8-amp fuse. Or, you may leave the 8-amp fuse in all the time reducing the protection when operating fixed. To simplify this problem, install a fuse-plug on the AC line cord with 1.5-amp fuses. Leave an 8-amp fuse in the Sixer all the time.

• **Headphone Jack.** If you would like to use headphones or a remote speaker add a phone jack on the front panel. The speaker will always be on if you follow Fig. 6. The phone will disable the speaker if you follow Fig. 7.

PARTS LIST

C1—10 mmf, 5% silver-mica capacitor (see text)
 C2, C3—.001, 600V disc capacitor
 D1—1N34 diode
 J1—Non-shorting phone jack (see text)
 M1—O-1 MA. milliammeter (Lafayette MS-454 or equiv.)
 R1, R2—4,700-ohm, 1/2-watt resistor
 R3—390,000 ohm, 1/2-watt resistor
 RFC—Ohmite Z-50 choke
 S1—SPDT toggle switch
 Misc.—Fused plug, #22 enameled wire, 8 mc crystals (U.S. Crystals, 1342 South La Brea Ave., Los Angeles 19, California) Crystal socket

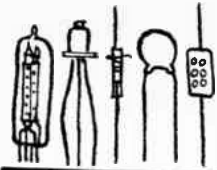

BEGINNERS PAGE

how to make a MIKE

IT'S easy to make your own microphone, especially if it's a carbon mike—the simplest type and the least difficult to adjust.

The carbon mike's operation is based on the ability of carbon to conduct an electric current. If a battery is connected across a piece of carbon a current will flow. The magnitude of the current depends on how tightly the carbon particles are packed together. The tighter the particles, the greater the current.

Let's replace the carbon rod with a container of loosely packed carbon granules and connect the battery leads to opposite sides of the container. The pressures generated by the sound waves of your voice will compress the granules to varying degrees in step with your speech. This will

vary the current flow. If the mike is connected to an amplifier through a battery and transformer, your voice will be reproduced at the amplifier's output.

Start building the mike by removing the carbon rod from a dead flashlight battery. Saw off the flat end of the battery case, scoop out the stuffing and pull out the carbon rod. Crush the rod with a pair of pliers and grind up the particles by using a round file or a metal rod as a rolling pin. Place the

granules in a small plastic (don't use metal) bottle cap and connect as shown.

The transformer may be a table-radio audio-output type with a 3.2- or 8-ohm secondary (used here as the primary) and a primary (used here as a secondary) of several thousand ohms. Or an old power transformer will do. Use the

filament winding as the primary and the plate winding as the secondary. Connect a plug to the secondary to match your amplifier's input connector. When you connect the alligator clips make sure they're well surrounded by the carbon granules.

Since it would be inefficient to speak directly into the mike element, you must use a paper tube to concentrate your voice. Make the tube from a sheet of 8½x11-inch paper rolled into a tube 2 or 3 inches in diameter.

Scotch tape will hold the paper together.

Flatten the tube slightly so the mike element will stay in place on the top. Plug the transformer into the magnetic-cartridge input of your amplifier, get close to the open end of the tube and start talking. Your voice is coupled by the tube to the granules. While talking, slide the mike back and forth for best sound. If the sound is weak, use two batteries.—H. B. Morris

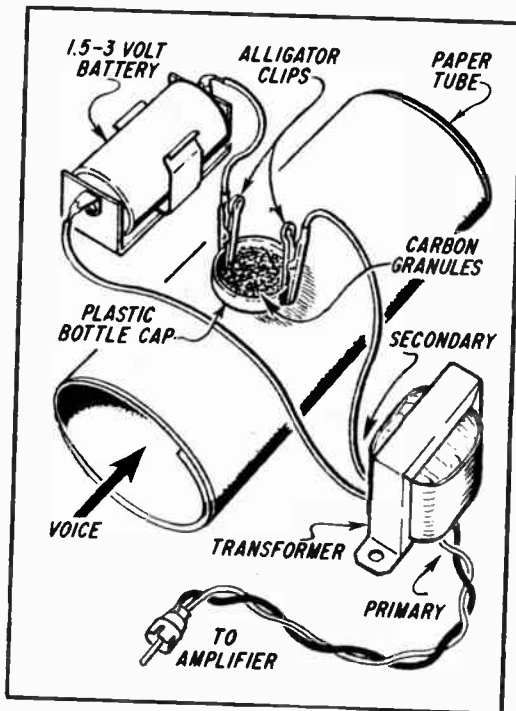

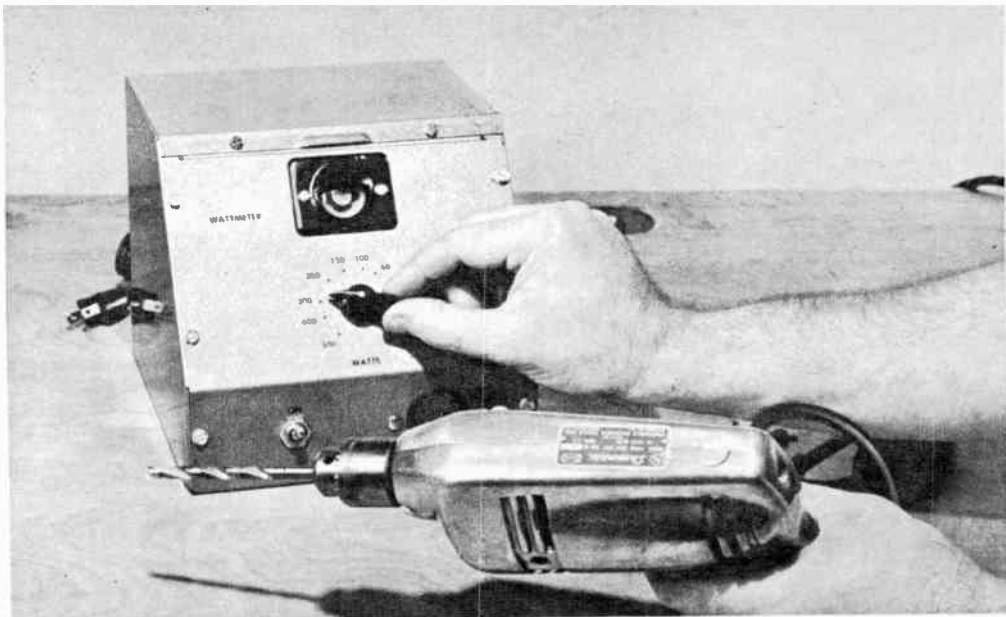

Magic Eye WATTMETER

Easy-to-build test instrument measures the power consumption of electronic equipment and appliances.

By Chet Stephens

WANT to know the actual current consumption of equipment that keeps popping fuses? Need a quick way of determining when that intermittent turns up in the gear you're servicing? Are you sure your home-brew project is fused properly? How about being able to figure in advance what it will cost to operate a new appliance? EI's Magic Eye Wattmeter will give you the answer to these and other power consumption problems, quickly, easily and accurately.

The wattmeter has a range of 15 to 1,000 watts. To determine a device's power consumption, just plug it in test receptacle SO1, turn R3 until the magic eye tube's shadow closes, then read the power directly on the dial.

If the wattmeter looks a bit more complex than others you've seen it's because of its extra stability and expanded dial. The calibration will hold indefinitely and the low-power calibration marks are not squeezed together. We've included a three-prong receptacle for appliances with a three-prong plug.

Construction

The wattmeter is built in a 6x6-inch sloping-panel cabinet. Since wiring is not critical, any layout can be used. The ground lug of SO1 need not be connected to the chassis as the three-prong socket is used merely to save you from buying a three-prong plug adaptor.

T1 is a special current transformer and there is no substitute. (Contrary to what you may have read in the past, do not try to use a 2.5-volt filament transformer for T1.) T1 is available only from Allied Radio

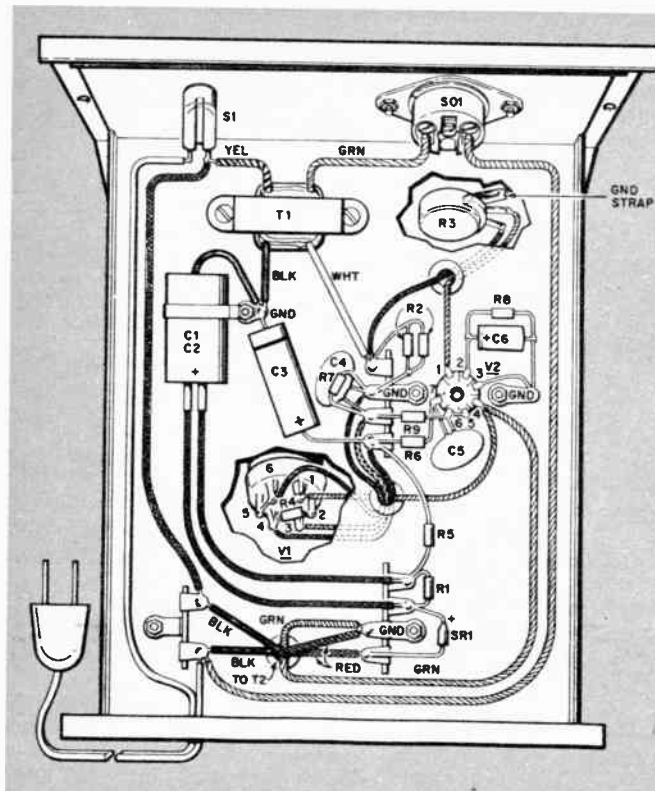

Chassis is shown in cutaway in pictorial to indicate connections to V1's socket and R3. Use a standard chassis-mount AC receptacle if your appliances don't have three-prong plugs. Note carefully the connections to SO1 and be sure you don't connect one side of the AC line to the ground lug.

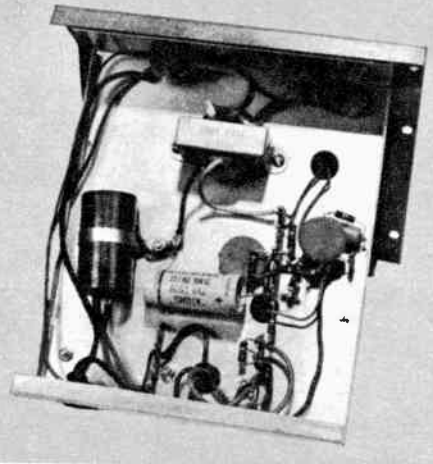

and should be ordered exactly as specified in the parts list.

Since T1 is connected on the instrument side of S1, the appliance under test is turned on and off with the wattmeter. If testing is limited to 500 watts, S1 should be rated for at least 4 amperes at 115 VAC. If you want to measure up to 1,000 watts, S1 must be rated for at least 9 amperes at 115 VAC.

R1 must have a logarithmic taper or both the high- and low-wattage dial markings will be bunched together. For extra sensitivity in the 5-to-25-watt range, remove one of the 100-ohm resistors (R2). V1 must be a 6E5 or it will be impossible to make accurate low-wattage measurements. Don't substitute a 6U5 or one of the older tube types marked 6E5/6U5.

V1 is mounted in an Amphenol tuning eye assembly which consists of a bezel, bracket, tube clamp and pre-wired socket (R4 is wired in the socket).

Calibration

Without an appliance plugged into SO1, turn on S1. After a few seconds V1 will glow green except for a dark shadow area approximately 45 degrees wide. Adjust V1 so its shadow is at the bottom. Next, rotate R3. There should be no change in the shadow angle. If V1 fails to glow or if rotating R3 changes the shadow angle, check your wiring.

Rotate R3 fully clockwise and mark a zero on the panel opposite the pointer knob. Should the knob become loose on the shaft, reset it to this mark.

You can calibrate the wattmeter with household light bulbs but use standard, quality brands. Some of the so-called lifetime bulbs consume less than the marked wattage. Connect a 100-watt bulb to SO1 and advance R3 until V1's shadow just closes. Be sure the shadow edges don't overlap. Mark 100 watts on the panel opposite R3's pointer. For higher-wattage calibrations, connect sev-

eral bulbs in parallel up to 1,000 watts.

When you advance R3 don't go beyond the point where the shadow closes. It takes a second or two for V1's shadow to open when you back off R3, making it difficult to find the point where the shadow closes. Always start with R3 fully counterclockwise and advance it slowly to prevent shadow overlap.

Using the Wattmeter

Often an intermittent in electronic equipment will be reflected by an increase in power consumption. By adjusting R3 so the shadow opens just slightly, the intermittent will cause the shadow to close. This spares you the job of keeping close tabs on the equipment waiting for the intermittent to reappear.

To determine the correct size fuse for a home-brew project, measure the power consumption and use the formula $I = W/E$ (I is current, W is power consumption in watts and E is the line voltage).

In testing to determine fuse size you

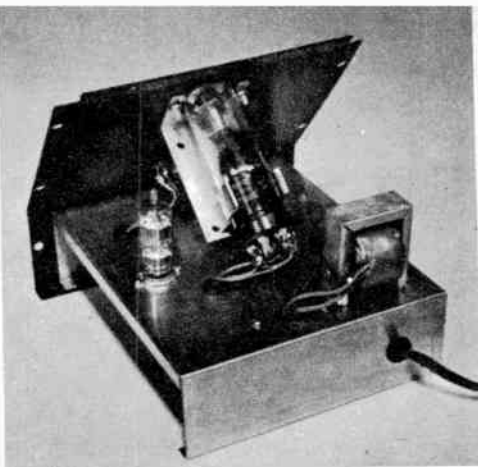

Top-chassis view. Wattmeter could be built in a smaller cabinet if portability is important.

also may solve the problem of having fuses pop for no apparent reason in equipment that is operating normally otherwise. It is not unusual for aging equipment to consume more power than it did when it was new (deteriorating filter capacitors and changing resistance values will increase current consumption enough to blow the fuse.)

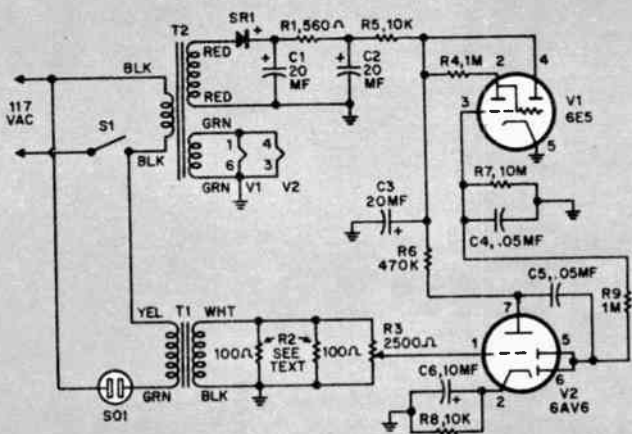

Load, in series with primary of current transformer T1, produces a voltage across secondary of T1 proportional to current consumption of appliance under test. Negative voltage on V2's diode plates (pins 5 and 6) is coupled to grid of V1. The greater the load, the greater the DC voltage applied to V1, the narrower the shadow angle. In operation, the setting of R3 is changed in proportion to current consumption of load so the same voltage is applied to the grid of V1, causing its shadow angle to be zero degrees. From 500 to 1,000 watts scale is crowded, so take care in marking dial or use larger knob.

Resistors: 1/2 watt, 10% unless otherwise indicated
 R1—560 ohms R2—100 ohms (see text)
 R3—2,500-ohm log-taper potentiometer (see text)
 R4—1 megohm (see text) R6—470,000 ohms
 R5, R8—10,000 ohms R9—1 megohm
 R7—10 megohms
 C1, C2, C3—20 mf, 250 V electrolytic capacitor
 C4, C5—.05 mf, 500 V ceramic disc capacitor
 C6—10 mf, 10 V electrolytic capacitor
 SR1—Silicon diode, 100 ma, 400 PIV

PARTS LIST

T1—Current transformer, Allied Radio Corp., 100 N. Western Ave., Chicago 80, Ill. Stock No. 39 A 842. \$1.03 plus 65 cents postage.
 T2—Power transformer: 117 V primary, 125 V @ 15 ma and 6.3 V @ .6 A secondaries. (Allied 61 G 410 or equiv.)
 S1—SPST toggle switch (see text)
 SO1—AC receptacle (Amphenol 160-2)
 V1—6E5 tube V2—6AV6 tube
 Misc.—Magic eye tube mounting assembly (Amphenol 58-MEA6; Lafayette CM-49)

TELEPHONE BELL EXTENSION

By Al Toler

SEVERAL million of Mr. Bell's customers have telephone extensions of one type or another—upstairs, downstairs, in the shop, outdoors or in the barn. An extension assuredly is handy but it is difficult to move one around or adapt it to a momentary situation. Besides, a certain amount of money is involved in having an extension, and often you merely want to know your phone is ringing; you don't particularly want a full-service telephone at hand.

El's telephone bell extension is an alerting device. Energized by the ringing signal in your phone, it rings a bell or lights a bulb or turns on some other signaling device at any remote location you choose. Hook it to a large outside bell and it could summon you from half a mile away. It's more likely, however, that you'd want to locate the extension bell in your upstairs bedroom if your phone is downstairs and you think its ring might not awaken you at night.

The extension is not connected directly to your phone (the phone company frowns on direct connections), and the all-transistor rig costs less than \$10 to build.

It works this way: When a call comes through, the extension's relay connects the 6.3-VAC secondary of T1 to the output terminals to energize an external bell. But you can use the output circuit in several other ways which we'll mention later.

The extension also can be used as a remote power sensor. For example, set it up near a washing machine in the

basement and it will turn on a signal light upstairs to tell you when the wash/dry cycle is completed. Or if you're checking your boiler's operation and don't feel like spending a day in the basement watching the cycling, you can set up the extension so you get a visual or aural indication of the boiler's operation in your living room. The extension's applications for monitoring electrically-operated devices are practically unlimited.

Construction. The extension's relay amplifier is built on a perforated-board subassembly. Flea clips are used for tie points. The wiring is straightforward and no particular care has to be taken in assembly. Just remember that relay RY1's frame is the common switch terminal and it should not touch any other components or the metal box.

C2 may give you some trouble; it is a high-capacity electrolytic and its leakage current may cause the amplifier to operate improperly. Do not mount C2, therefore, in an inaccessible place since you may have to change it after testing the unit.

The transistor and diode leads are short so be certain to use a heat sink, such as an alligator clip, on the leads to prevent overheating when soldering.

T1 can be any low-cost, low-current, 6.3-volt filament transformer. Notice that the power supply's output is negative with respect to ground. Take particular care that the polarity of SR1 and C4 is correct. Under both standby and

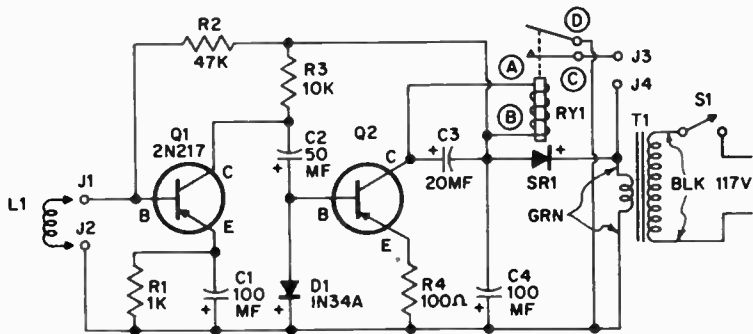

RY1's coil is 335 ohms and its contacts are rated at 2 amps. If you plan to use the extension to operate a signaling device that draws greater current, get a relay with heavier contacts or use RY1 to energize the coil of a remotely located relay.

PARTS LIST

Resistors: 1/2 watt, 10%.

R1—1,000 ohms R2—47,000 ohms

R3—10,000 ohms

R4—100 ohms

C1—100 mf electrolytic, 6 VDC or higher

C2—50 mf electrolytic, 10 VDC or higher

C3—20 mf electrolytic, 10 VDC or higher (see text)

C4—100 mf electrolytic, 15 VDC or higher

L1—Telephone pickup coil (Lafayette MS-16)

T1—6.3 V filament transformer

RY1—SPDT relay, 6 V coil (Potter

and Brumfield RS5D)

Q1, Q2—2N217 transistor

D1—1N34A diode

SR1—Silicon rectifier, 50 ma, 50 PIV

or higher

S1—SPST toggle switch

J1-J4—Insulated binding posts

Misc.—Cabinet, terminal strip

Mount binding posts J1-J4 with insulating washers so they don't touch cabinet. Watch the polarity of D1, SR1.

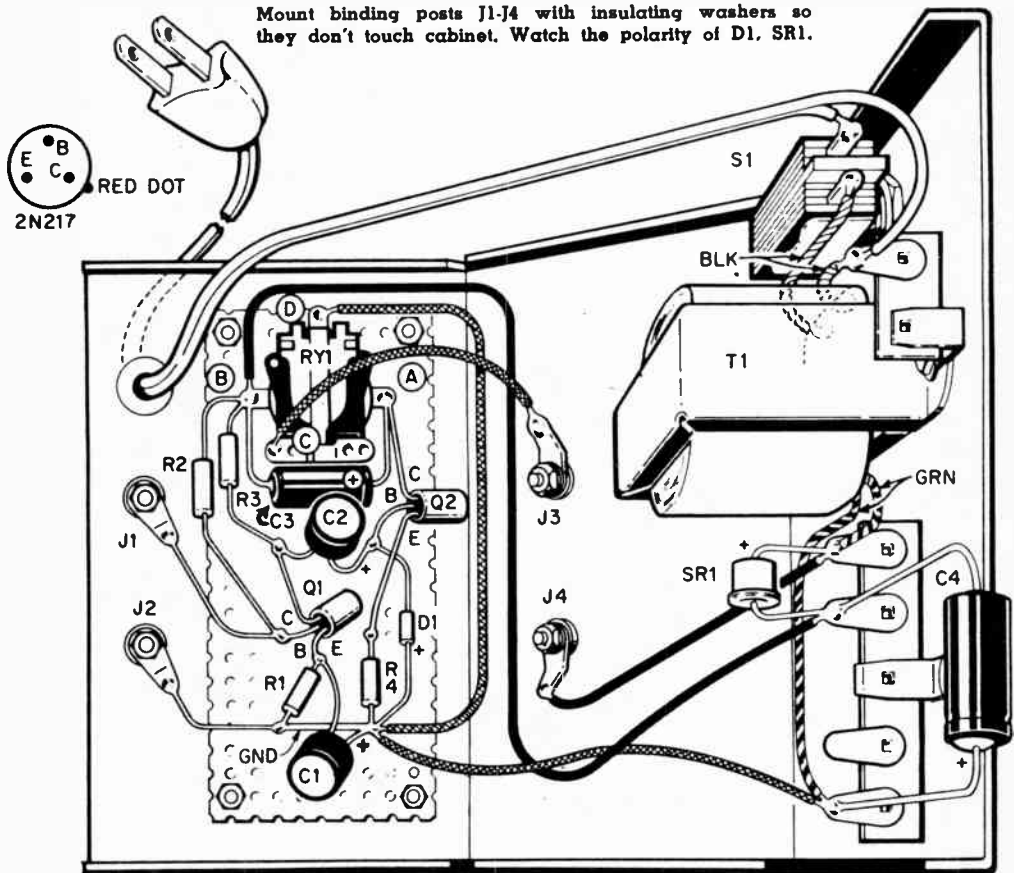

TELEPHONE BELL EXTENSION

operating conditions, the power supply delivers about 9 volts DC.

C3 may be required to prevent RY1 from chattering. Depending on

your local phone system, RY1 may close and stay closed when the phone rings or it may open and close (chatter) in time with the ring signal. If it chatters, simply connect C3 as shown.

The amplifier subassembly board is mounted on one end of a 3x4x5-inch Minibox. The power supply components are mounted on the other end of the box. To avoid shorting the flea clips, which extend through the perforated board, place a rubber grommet between the board and the cabinet over each of the corner mounting screws. To be doubly safe, put a heavy piece of paper between the cabinet and perforated board.

L1 is a standard telephone pickup coil; however, do not substitute some other type for the one we have specified. The DC resistance of the coil is part of Q1's base-bias circuit and if a coil with a different DC resistance is used, the circuit may not operate.

Checkout. Connect the shield of L1's cable to J2 and connect the inner conductor to J1. Connect a 0-20 milliammeter between the power supply and the amplifier. In the pictorial, disconnect the lead coming from the amplifier to the lug on the terminal strip to which C4 and SR1 are connected. Connect one side of the meter to the lug and the other side to the lead from the amplifier.

When power is applied, RY1 will close momentarily and the meter will indicate about 20 ma. When RY1 opens the current should fall to about .5 to 2 ma. If the idling current exceeds 2 ma, C2 has excessive leakage and should be replaced with another unit that keeps the idling current below 2 ma.

Next, check L1 by placing it near a soldering gun that is turned on, or near T1. RY1 should close for about 3 to 5 seconds. If RY1 fails to close, check for a wiring error.

Installation. Place L1 under the phone cradle. When the phone rings RY1 should close. If RY1 does not close, move L1 to a different position—perhaps under the phone. Usually the extension will work the first time if L1 is strapped to the side of the phone.

If the extension is to be used to indicate that a motor has started, L1 should be able to pick up the field within a foot of the motor.

You can use the extension to close an external circuit rather than supply power to a separate bell. To do so, connect J4 directly to terminal D on RY1. Make sure D and J4 are not both connected to the secondary of T1.

How it Works. L1 picks up the AC field set up by the ringer coil in your phone when a call comes through. The voltage across L1's terminals is amplified by Q1 and fed to Q2 causing Q2 to conduct. Q2's collector current, which flows through RY1's coil, increases and causes RY1 to close. When contacts C and D of RY1 close, the other side of 6.3-VAC secondary of T1 is connected to J3.

If you want to mount bell in Minibox there is plenty of room for it in center. If bell is to be located externally, a smaller box can be used.

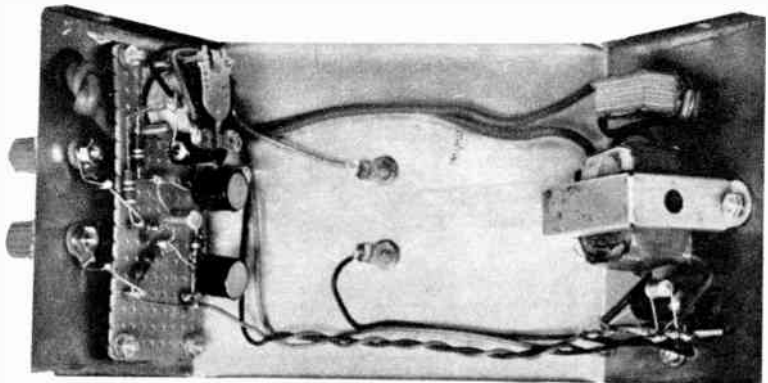

Handyman's CABLE & PIPE FINDER

By Bert Mann

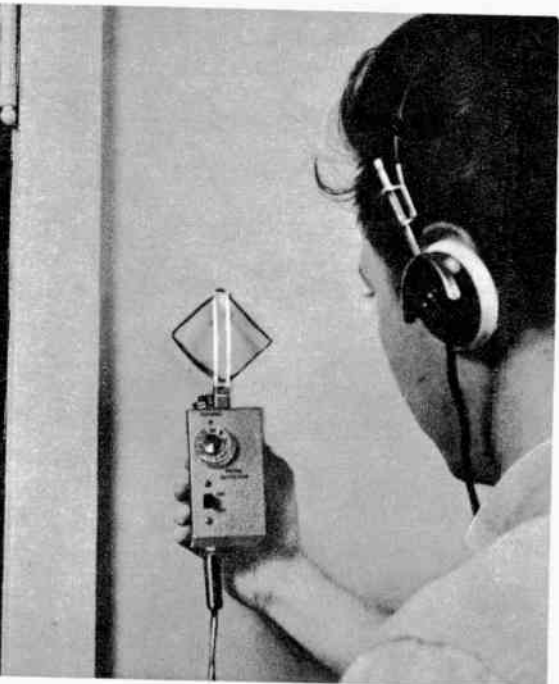

WE all know about the proverbial needle in a haystack, but it's only when you try to locate something like a water pipe or a BX cable in a wall that the saying has real meaning. Sometimes you get down to such destructive probing as is done with a hefty drill.

A much more palatable type of probing can be done with the Handyman's Cable & Pipe Finder. In seconds it will lead you unerringly to those elusive pipes, electrical junctions and cables, structure beams, wire lath and the like.

The finder will run you about \$12 and is sensitive enough to indicate the center of a pipe within a quarter inch. The unit is designed specifically for scanning walls, floors and other such structural members, having a range of 3 to 4 inches. We do not recommend that you try souping it up or start using it to look for Civil War relics. Instead, use one of the special instruments designed to look for buried treasure.

Construction. Our Finder is built in a 2¼x2¼x4-inch Minibox. To keep the size small we made a printed-circuit board with standard copper-clad perforated stock. All major components except tuning capacitor C2, switch S1,

battery B1 and jack J1 are mounted on the board. Follow the diagrams as we run through the steps in preparing the board.

Cut a piece of perforated board 15 holes wide and 10 holes high. On the copper-clad side, letter the ten rows A through J and mark the 15 columns one through 15, as shown in Fig. 1. Place a resist dot over the holes indicated (B1, G7, etc.) and join the dots with resist tape (the heavy lines in Fig. 1). Place the board in a glass or plastic tray and pour in etchant solution to cover it. Agitate at least once every minute.

After about 15 minutes, examine the board. (Do not touch it with your bare fingers; etchant solution is caustic and will burn your skin.) If the *uncovered* copper has been removed, rinse the board under running water, peel off the dots and tape and clean the remaining copper foil with scouring cleanser. Rinse again.

Figure 2 is a diagram of the reverse side of the board. Notice that here the letters are on the right side and the numbers now increase in order from right to left. Install all components and the jumper (as shown in Fig. 2),

bend the leads slightly, then apply a drop of solder to each lead at the foil. When soldering the transistors, hold the leads with a pair of pliers to prevent heat damage. Then clip all leads short.

Connect C4 to lugs 1 and 2 on T1. Solder one-inch leads to T1's lugs (including lugs 1 and 2) before mounting it on the board. The lead from lug 4 (near the green dot) goes into hole G7. All of T1's other leads should fall into place as indicated on the board. Follow Fig. 4 when installing the board in the cabinet, keeping the parts side up (they aren't shown in place in Fig. 4). Connect leads from SO1, C2, S1, B1 and J1 to the points indicated in Fig. 2.

To wind coil L1, drive four nails into a wood block so they form a 2 1/4 x 2 1/4-inch square. Wind 50 turns of No. 30 enameled wire around the nails. At the 50th turn, bring the wire out in a three-inch loop and wind five more turns. Saturate L1 with General Cement Q-dope. After the Q-dope sets, remove the nails and let the form dry overnight. Now, cement L1 to a 6 x 1/2 x 1/8-inch-thick strip of plastic or Masonite as shown in Fig. 3, and mount the coil assembly on the Minibox cover.

Scrape the enamel insulation from the coil leads and solder hookup wire to each one. Tape the hookup wire to the support strip. The first turn of L1 goes to pin No. 1, the tap to pin No. 2 and the last turn to pin No. 3 of PL1.

Adjustment. Before L1 is plugged in, turn on the Finder and place it near a radio tuned to a vacant spot on the dial around 750 kc. Adjust T1's slug with a plastic alignment tool until the radio is silenced. Plug a pair of high-impedance phones and L1 into the Finder and adjust C2 until you hear two loud whistles in the phones. These whistles should occur when C2's plates are a quarter to half meshed. Readjust C2 for the *louder* of the two whistles and put a mark on the dial and panel. This will be your operating setting for C2.

Operation. Adjust C2 so the dot on its dial is opposite the dot on the panel. The exact setting isn't terribly important so long as you hear a tone of about 2,000 cps in the phones. At this setting even a slight change in the tone's

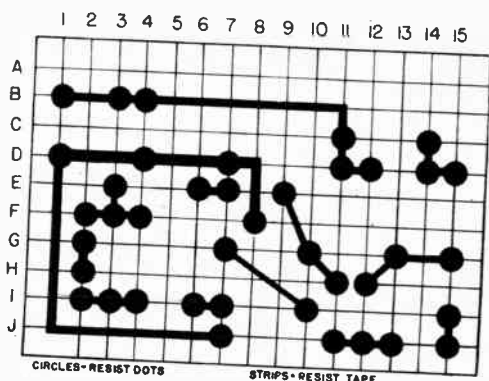

Fig. 1 (above)—Copper-clad side of circuit board shows you where to apply resist dots and tape. Fig. 2 (below)—Parts location on reverse side is shown. Q1-B, for example, is for base lead of Q1.

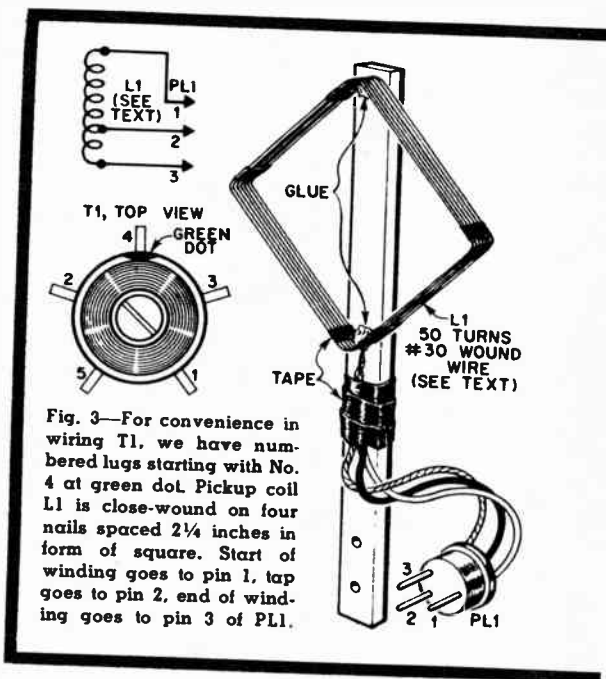
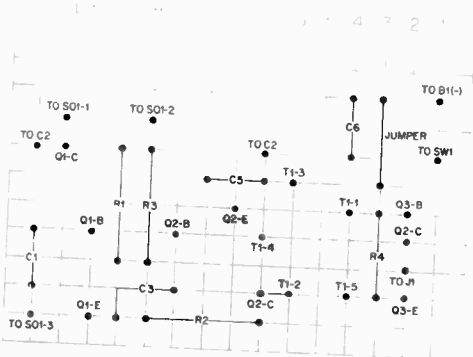

Fig. 3—For convenience in wiring T1, we have numbered lugs starting with No. 4 at green dot. Pickup coil L1 is close-wound on four nails spaced 2 1/4 inches in form of square. Start of winding goes to pin 1, tap goes to pin 2, end of winding goes to pin 3 of PL1.

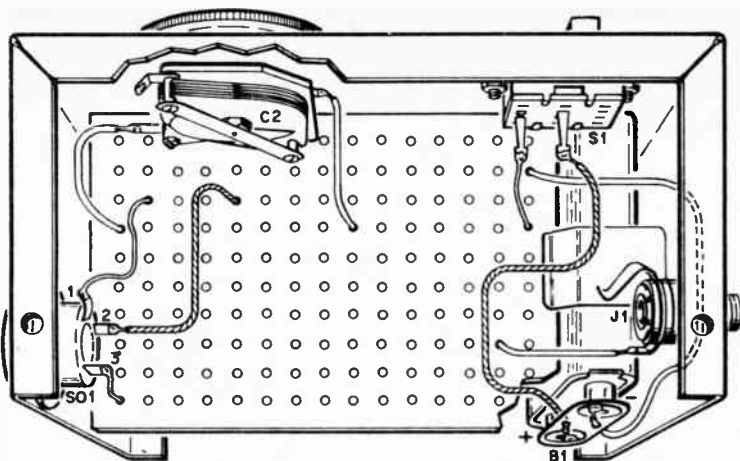
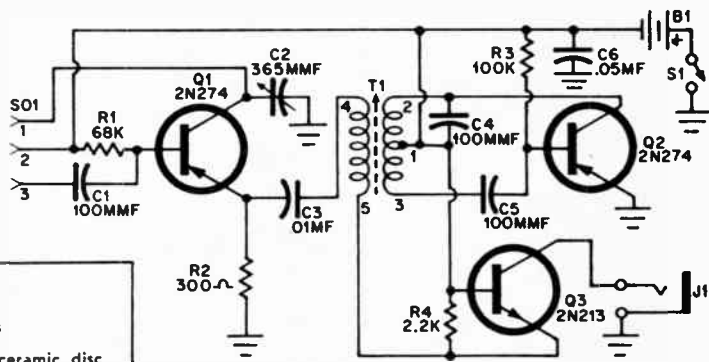

Fig. 4—After circuit board is installed, connect leads to components mounted in cabinet, using the diagram in Fig. 2 as a guide. If you'd rather not attempt to make a printed-circuit board, use regular perforated board and flea clips.

Oscillator Q2 operates at a frequency that is determined by the setting of T1's slug. Frequency of oscillator Q1 is set close to Q2 by C2. L1's inductance is changed when it is brought near a pipe. This shifts frequency of Q1 and tone in phones.



- PARTS LIST**
- Resistors: 1/2 watt, 10%
 R1—68,000 ohms R3—100,000 ohms
 R2—300 ohms R4—2,200 ohms
 C1, C4, C5—100 mF, 50 V or higher ceramic disc capacitors
 C2—10-365 mF variable capacitor (Lafayette MS-445 or equiv.)
 C3—.01 mF ceramic disc capacitor
 C6—.05 mF, 50 V or higher ceramic disc capacitor
 L1—Pickup coil (see text)
 T1—Oscillator coil (Lafayette MS-265)
 J1—Phone jack
 PL1—3-prong plug (Amphenol 78-535)
 SO1—3-prong socket (Amphenol 71-35)
 Q1, Q2—2N274 transistor
 Q3—2N213 transistor
 S1—SPST slide switch
 B1—9-volt battery
 Misc.—2 1/4 x 2 1/4 x 4-inch Minibox, copper-clad perforated board (Lafayette MS-847), resist dots (Lafayette MS-737), 1/2-inch tape-resist (Lafayette MS-736), etchant (Lafayette MS-729), No. 30 enameled wire.

frequency will be apparent when you hold L1 near metal. Try it out on a piece of pipe. Hold the Finder so L1's support rod is parallel to the pipe and move L1 back and forth across it. As you approach the pipe the tone will either rise or fall in frequency.

If you get a rise in pitch but prefer a fall, move the Finder away from the pipe and readjust C2. Now when L1 is directly over the pipe the tone should be at minimum or not heard at all. This will depend on how close L1 is to the pipe. When working over decorative

tile, adjust C2 with L1 against the tile. Wire lath in walls produces a fluttering tone or no tone.

How It Works. Oscillator Q2 operates at a fixed frequency. The frequency of oscillator Q1 is close to that of oscillator Q2 and can be adjusted with C2. Their outputs beat together and produce sum and difference frequencies. (We are interested only in the difference frequency.) For example, if oscillator Q2 operates at 800 kc and C2 maintains oscillator Q1 at 798 kc, the difference frequency is 2 kc.

When L1 is brought near metal its inductance changes, causing a change in the frequency of oscillator Q1. This lowers or raises the pitch of the tone.

The important thing to listen for as you move L1 over the wall is a change in pitch—from high frequency to a lower frequency or a null.

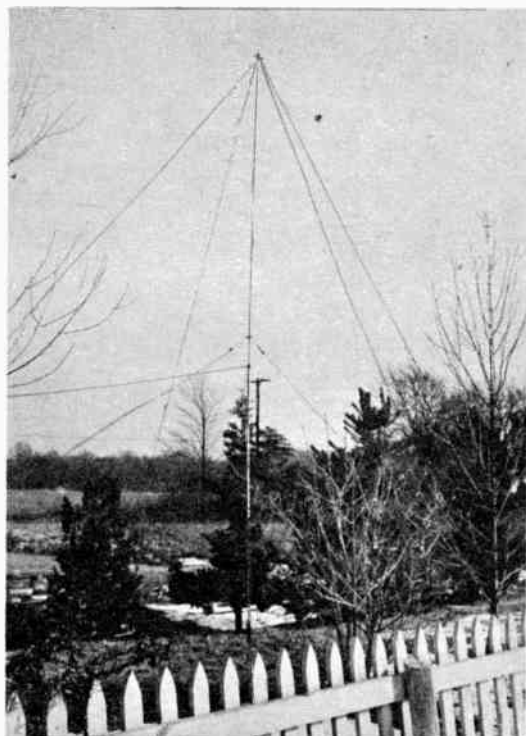

3-BAND MAINMAST

**Little work and less space
are required to build this
antenna for the low bands.**

By Edward M. Noll, W3FQJ

ONE of the biggest problems faced by the ham who wants to operate on the lower-frequency (ergo, longer-wavelength) bands is the space required for a decent antenna. For a Novice, it's a real headache because he is restricted to certain sections of 80, 40 and 15 meters if he wants to go in for anything other than purely local contacts.

If you happen to have a small ranch, you can indulge in that old favorite of hamdom, the half-wave dipole, since one cut for 80 meters runs a mere 126 feet from end to end. But when your open range is a city lot, life on 80 is a bit hectic.

Our 3-Band Mainmast Antenna, operating efficiently on 80, 40 and 15 meters, is designed to give you a decent skyhook in minimum space. It can be put up in a back or side yard, or mounted on the house or garage.

The Mainmast's unique feature lies in the fact that the four guy wires serve as parts of the antenna's radiator. They are attached electrically at the top of the mast and are insulated from the ground stakes. There also is an insula-

tor at the bottom of the mast itself.

The mast of the antenna is made up of two 10-foot lengths of half-inch steel electrical conduit (or $\frac{3}{4}$ -inch aluminum conduit). A standard coupling is used to join the two sections. A TV-type guy ring is dropped down the mast and is held at the center by the larger diameter of the coupling. A clamp-on type guy assembly is fastened to the top of the mast.

A good ground is important. For yard erection, use a 10-foot pipe driven into the ground. For roof mounting, such as on the chimney, run a large-diameter ground wire to the vent pipe or the cold-water system. The antenna can even be mounted on the vent pipe.

For an insulator between mast and ground, use a 6-inch length of $\frac{7}{8}$ -inch inside-diameter phenolic tubing with quarter-inch walls to provide rigid support. Four bolts hold the tubing in place between ground and mast. Attach solder lugs to one upper and one lower bolt to provide connecting points for the coaxial transmission line.

The guys, which we'll discuss in more

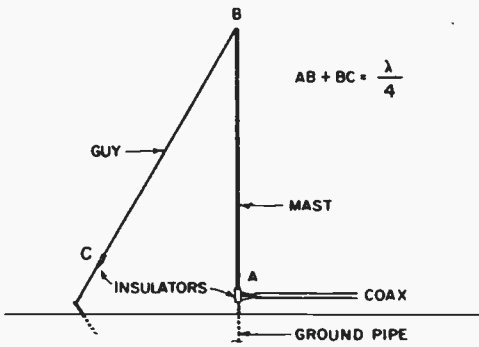

Fig. 1—Single guy wire (BC) is connected to 20-foot mast (AB) to form quarter-wave arm of antenna; second arm improves bandwidth, guying.

detail in a moment, should be about 14-gauge wire. Be sure to space them roughly 90 degrees apart around the mast. The directional letters (N, S, E, W) in Figs. 2 and 4 are merely to remind you of the 90-degree spacing.

With a 1/4-wave cut to frequency, the base feed point displays a low impedance for matching to the transmission line and the low-impedance output of the transmitter. It so happens that any 1/4-wave job cut for 40 meters can be used efficiently on 15 meters, too, because 15 meters falls approxi-

mately on the third harmonic of 40 meters.

Each of the Mainmast's guys, when added to the length of the vertical, represents a quarter-wave antenna. Thus in Fig. 1, we would add the 20-foot length of the vertical (AB) to the length of the single guy (BC) to find its electrical wavelength. The mast length also would be added to the guy on the opposite side. In other words, the mast forms part of each quarter-wave arm of the antenna.

Figure 4 shows how the longer 80-meter guys are accommodated by running each wire to a ground stake and then bringing the end back up to a guy ring at the center of the mast. Depending on your installation, you may want to tape the transmission line to the mast up to the height at which the line can be run into the shack.

The inner conductor of the coaxial transmission line is connected to the bottom of the mast and the outer shield of the coax goes to the ground pipe.

The lengths of the four guys are shown in Fig. 2. To arrive at the proper length for a 1/4-wave against ground, divide your operating frequency in megacycles into 234 (using what is called the 234 Formula). Just for the record, the complete formula we're dealing with

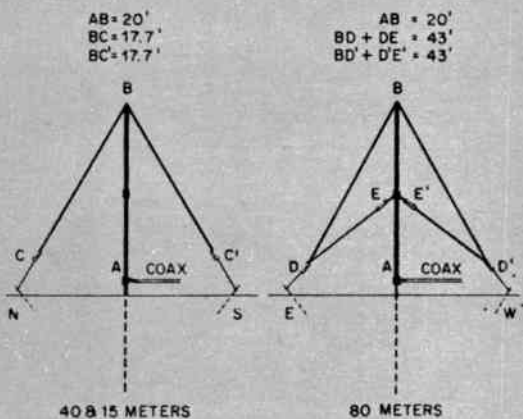

Fig. 2—Diagrams show approximate lengths for all sections. Guys BC and BC' operate on 40-15 meters; guys BDE and BD'E' are for 80 meters.

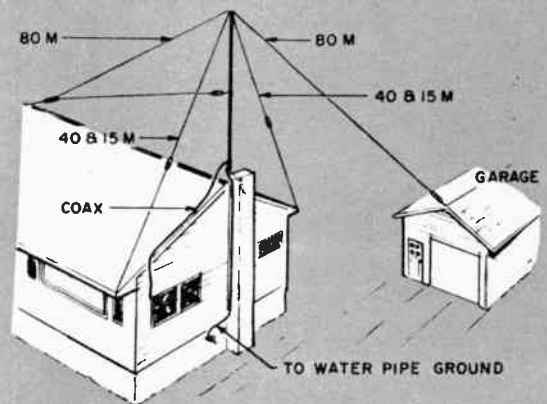

Fig. 3—Mainmast can be built in yard or mounted on building and, if there is space, one 80-meter guy can be stretched out, as in this drawing.

reads as follows:

$$\frac{\lambda}{4} = \frac{234}{F \text{ (mc)}}$$

where λ is the combined length (in feet) for the vertical (AB) and the guy (BC), and F is your operating frequency in megacycles.

The diagram at the right in Fig. 2 indicates that two of the guys should be 43 feet long. When you add the length of the guy (43) to the height of the mast (20), you get 63 feet, which is exactly what the formula gives you as the length of a $\frac{1}{4}$ -wave element cut for the center frequency of the 80-meter Novice band.

But the Mainmast, like any other antenna, is subject to some cutting-and-trying. The formula length for the 40-meter arms of the antenna simply did not operate efficiently for the author, who then went to the cut-and-try method. For resonance on both 40 and 15 meters, it was found that the shorter guys should be approximately 17.7 feet in length. We recommend that you try this length first. If you have trouble, start your own cut-and-try experiments.

In Fig. 3 we show how the Mainmast can be mounted on a chimney and, if space is available in one direction, one of the 80-meter guys can be strung out full-length to the garage or a pole.

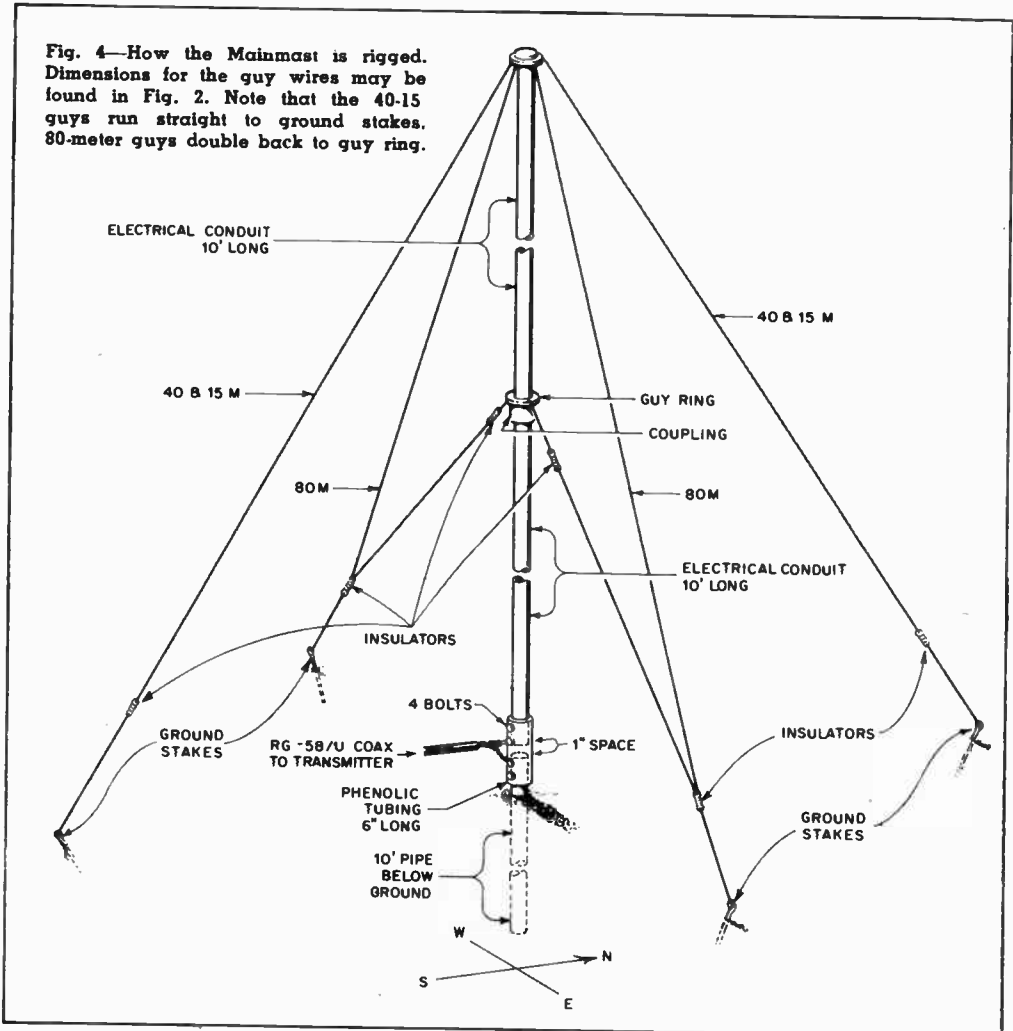

*In any CB application...you'll
outperform 'em all with a*
M E S S E N G E R



**Personal
Messenger**

Compact, hand-held 100 milliwatt or 1/2 watt models! Rugged and reliable - 11 transistors, 4 diodes. Twice the sensitivity and 40% more range than similar units with conventional circuitry - more output than similar units with same rated inputs!

- Cat. No. 242-101
100 milliwatts \$109.50 Net
Cat. No. 242-102
1/2 watts \$129.50 Net

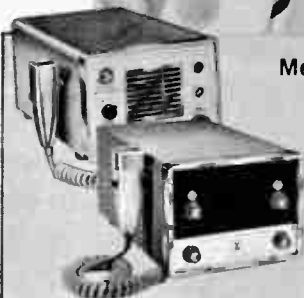

Messenger and Messenger Two

For mobile or base stations. High efficiency design makes full use of maximum allowable legal power. Excellent receiver sensitivity and selectivity. Automatic "squelch" control. 5 crystal controlled channels on the "Messenger" and 10 crystal controlled channels plus a tunable receiver on the "Messenger Two."

MESSENGER

- Cat. No. 242-127
115 Volts AC / 6 Volts DC... \$109.95 Net
Cat. No. 242-128
115 Volts AC / 12 Volts DC... \$109.95 Net

MESSENGER TWO

- Cat. No. 242-162
115 Volts AC / 6 Volts DC... \$169.95 Net
Cat. No. 242-163
115 Volts AC / 12 Volts DC... \$169.95 Net

New!

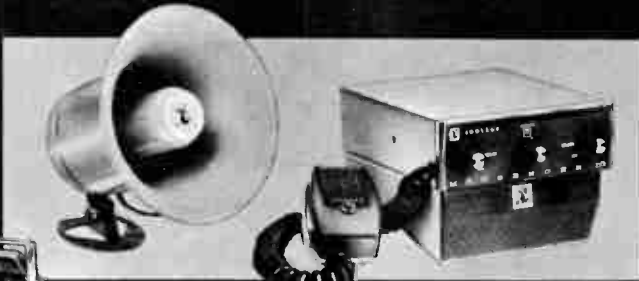

M E S S E N G E R III

The "Messenger III" offers everything you ever wanted in a CB transceiver... compact size, a husky signal, extreme sensitivity, razor-sharp selectivity - and complete flexibility for base station, mobile, public address, or battery powered portable use! Double conversion receiver - set-and-forget "Volume" and "Squelch" controls - 11 channel coverage - "Tone Alert" Selective Calling System available as accessory.

- Cat. No. 242-150 12 Volts DC Messenger III \$189.95 Net
Cat. No. 250-823 117 Volt AC Power Supply \$ 29.95 Net

WRITE TODAY

for full details

SEE YOUR DEALER/DISTRIBUTOR
AND ASK FOR A DEMONSTRATION



E. F. JOHNSON COMPANY

6811 TENTH AVE. S.W. • WASECA, MINNESOTA

World Radio History

This matcher peeps up your receiver to give you up to two more S-units.

By **RUSS COGAN**

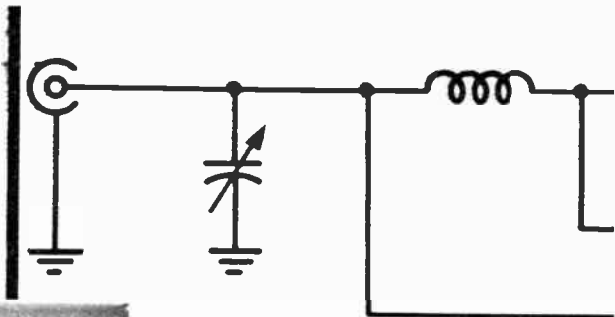

SWL

IF YOU own a fancy communications receiver equipped with an antenna-trimmer control, you've got it made. But if yours is a budget or surplus receiver hooked to a random-length antenna (and your rig doesn't have that trimmer control) we'd wager you're not satisfied with your set's sensitivity and could use EI's Antenna Tuner.

The tuner can match any antenna impedance to your receiver's input, giving you up to a 10db increase in signal (nearly two S-units) within the range of 1 to 30 mc.

Construction

The tuner is built in a compact 5¼ x 3x2⅞-inch Minibox. Since space is limited, follow the layout in the pictorial carefully when mounting C1, C2 and S1. To simplify construction, we used standard RF chokes instead of tapped or hand-wound coils.

Since S1 is detented for SPDT operation,

it must first be modified. Holding S1 sideways so the detent faces you, remove one tab on the left side of the detent stop and three tabs from the right side. The unused switch lugs (at the bottom in the pictorial) are used as tie point for the chokes. Don't attempt to wire the chokes directly to the terminals on the top of S1, which could cause shorting.

C1 and C2 have small copper trimmer straps. Remove the trimmer screws and cut off the straps before mounting. Wire to the sections of C1 and C2 that have the greater number of plates. This will produce good results from 10 to 30 mc. Actually C1 and C2 have little effect at low frequencies. If you're primarily interested in frequencies below 10 mc, connect the two sections of each capacitor in parallel. Install jumper wires between the two lugs on the top of C1 and C2 before mounting them in the cabinet.

Tuner is built in U-section of Minibox. Make sure C1, C2 and S1 don't block cover screw holes. Coaxial jack can be used for J1 if receiver has 50-ohm input. If receiver has high impedance input, use binding posts. Mount chokes and wires on S1 before installing in the cabinet.

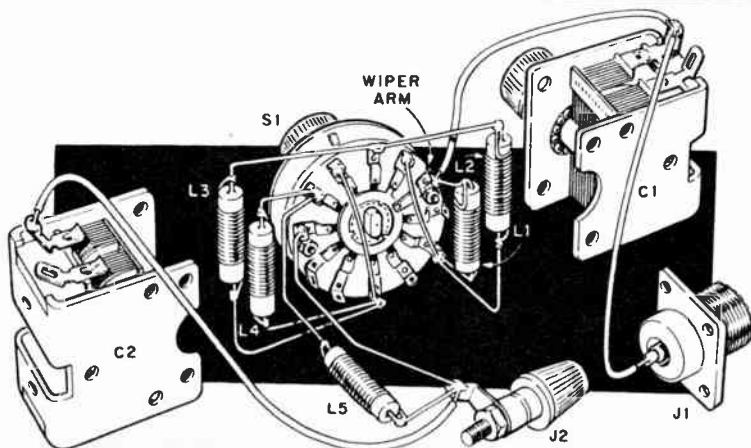

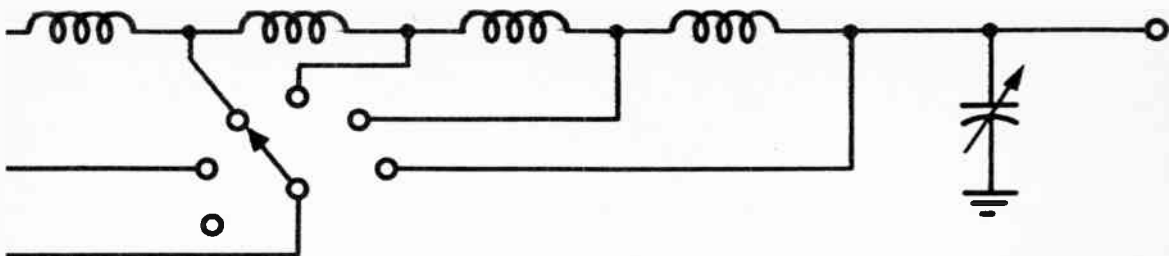

Antenna Tuner

Connect your receiver to J1 and your antenna to J2. Set S1, C1 and C2 full clockwise. The tuner is now out of the antenna line. Tune in a station and rotate S1 to the position that produces the strongest signal, then peak the signal with C1 and C2. C1 normally has little effect, but under certain conditions it may produce an extra S-unit of signal. Once the signal is peaked, try the next higher or lower position of S1 and then readjust C1 and C2.

It may be possible to find another setting of C1, C2 and S1 that will produce an even stronger signal. Try the tuner on all bands and list the peak settings of all controls.

Connection of the tuner to your receiver can affect sensitivity so try all possible connections to the receiver's antenna terminals. It is possible that the tuner will not improve performance above 15 mc with your particular receiver and antenna. If this is the

case, change L5 to a 1.5 microhenry choke (Stancor RTC-8516 or equiv.).

The tuner also can be used to reduce the signal from a strong local station which may be blocking your receiver. Adjust C1, C2 and S1 for *minimum* signal strength and you're in business. 📻

PARTS LIST

- C1, C2—Miniature two-gang superhet variable capacitor, 123 and 78 mmf sections. (Lafayette MS-261 or equiv.)
 J1—SO-239 coaxial connectors (see text)
 J2—Five-way binding post
 RF Chokes: All J. W. Miller Nos.
 L1—56 microhenries, 70F565A1
 L2—15 microhenries, 70F155A1
 L3—22 microhenries, 70F225A1
 L4—10 microhenries, 70F105A1
 L5—5.6 microhenries, 70F566A1
 S1—6-position, non-shorting rotary switch (Centralab PA-1001)

Inside view of the tuner. J1 is at the right and C1 is directly behind it. C2 and J2 are at the left.

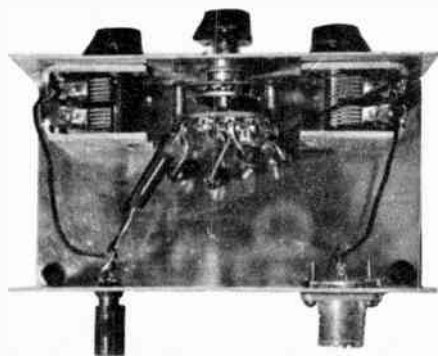

Combinations of C1, C2 and L1-L5 in this pi-network circuit match the antenna impedance to the receiver.

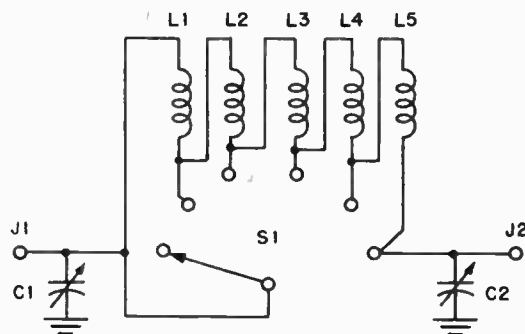

COMMAND

By Chet Stephens

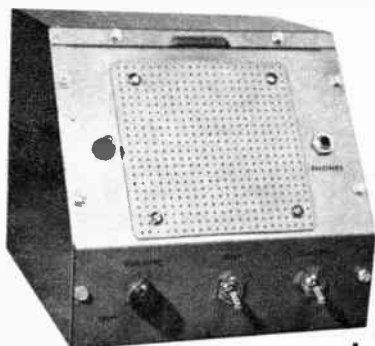
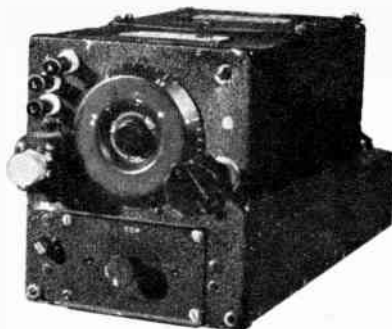

CONTROL CENTER

Try this easy, inexpensive way to get a hot receiver on the ham bands!

ONE of the great buys in surplus electronic equipment after World War II was (and still is) the Command series of Army/Navy receivers. There's a reason for the popularity of the sets. For about \$15 you get a receiver of outstanding design that is built like the Rock of Gibraltar.

Originally, the rigs were used in aircraft communications systems. Several models are available, which make it possible to tune from weather stations down around 190 kc right up to 9 mc. Three complete ham bands are covered by different Command jobs. The BC-455 model tunes 40 meters, BC-454 tunes 80 and R-25 tunes 160 meters. The table below lists the models by military designations and gives tuning ranges.

Popular as these receivers were, many people shied away from them because of the modifications and additions thought necessary to get them working. Most of the conversion plans now available show you the hard way to do it and require rewiring of the filaments and addition of a power supply and audio amplifier.

However, EI's Command Control Center (CCC) will enable you to get one of these receivers going with a mini-

mum of effort and cost. Modifications to the receiver are *not* necessary.

Our CCC provides B+ and 24 volts for the receiver filament circuit. A BFO on/off switch is provided, as well as a volume control (actually an RF gain control). The receivers originally were designed to drive headphones but the CCC contains an output transformer for speaker operation (phones still can be used). Some special parts are required but our parts list tells you where to get them.

While the CCC has only one receiver connector, a second or third switched connector can be added easily if you want to use two or more receivers without having to change the connecting cable.

Construction. The CCC is built on a 2x6x7-inch chassis which is mounted in a sloping-panel cabinet by the volume, BFO and standby controls. Only the

COMMAND RECEIVERS		
Model		Tuning Range
Army	Navy	
BC-453	R-23	190-550 kc
BC-946	R-24	520-1500 kc
—	R-25	1.5-3 mc
BC-454	R-26	3-6 mc
BC-455	R-27	6-9.1 mc

PARTS LIST

R1—100,000-ohm, 1/2-watt resistor
 R2—10-ohm, 1-watt resistor
 R3—50,000-ohm, linear-taper potentiometer with SPST switch
 R4,R5—240,000-ohm, 1-watt resistor
 C1—.01 mf, 500 V ceramic disc capacitor
 C2—8 mf, 450 V electrolytic capacitor
 C3—20 mf, 450 V electrolytic capacitor
 S1—Part of R3
 S2,S3—SPST toggle switch
 L1—Choke: 13 hy, 65 ma, 385 ohms

(Allied Radio 61 G 487 or equiv.)
 SR1,SR2—1N3196 silicon rectifier (RCA)
 J1,J2—Shorting-type phone jack
 P1—5-pin cable connector (Amphenol 91-MPM6L or equiv.)
 *P2—Connector for BC-453 Command receiver (fits all models)
 SO1—5-pin female chassis connector (Amphenol 78-565 or equiv.)
 *T1—Power transformer. Secondary: 500 V center-tapped @ 60 ma; 24-volt filament winding
 SP1—Speaker. 4", 3.2-ohm voice coil

F1—1 amp. fuse
 T2—Output transformer. Primary: 5,000 ohms; secondary: 3.2 ohms (Allied Radio 62 G 064 or equiv.)
 NLI—Panel-light assembly (Dialco No. 933 or equiv.) or NE-51H neon lamp and socket
 Misc.—Sloping-panel cabinet (Bud C-1584HG or equiv.), 2x6x7-inch chassis (Bud CB-38 or equiv.)
 *Available from Fair Radio Sales Co., Inc., 2133 Elida Road, Lima, Ohio. \$6.45 plus shipping for T1 and P2

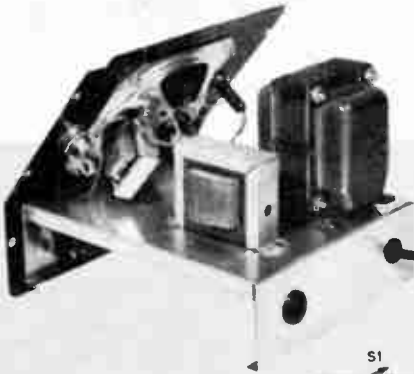

Underside of CCC chassis. Solder the ground strap supplied with R3 to R3's bottom lug. Speaker, pilot lamp and phone jack are mounted on the cabinet's front panel.

Rear view of the Control Center. Mount transformers as shown to prevent AC hum pickup by the output transformer.

CCC schematic. Volume control R3 changes gain of RF stage in receiver. Output for phones at J2 is high impedance. Closing standby switch S2 applies DC power to the receiver.

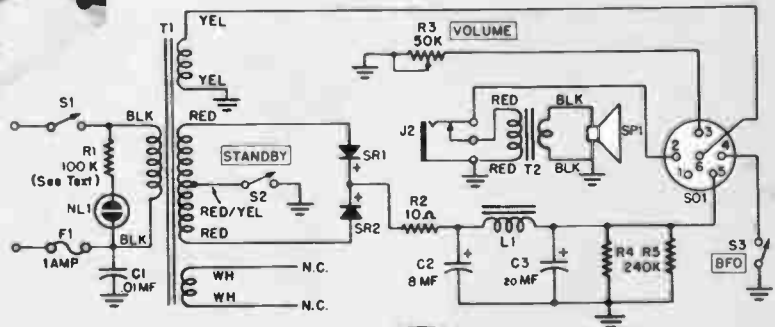

NOTE: WHITE LEADS FROM T1 ARE NOT USED

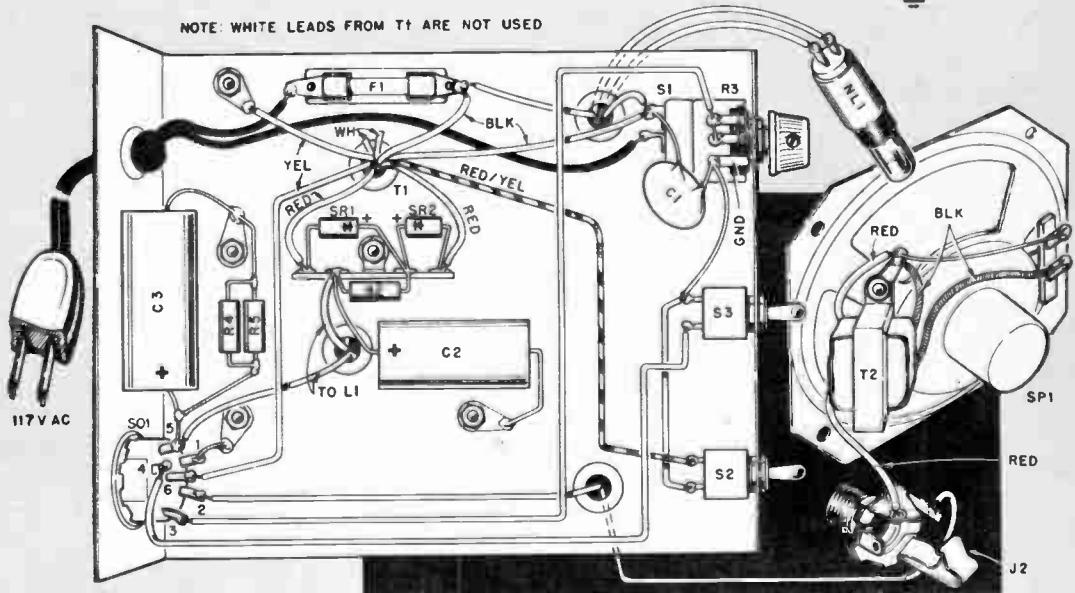

COMMAND

CONTROL CENTER

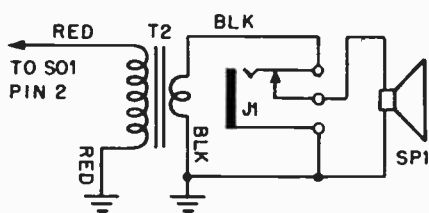

If your phones are low-impedance, connect a shorting-type jack across T2's secondary as shown.

four-inch speaker, power indicator NL1 and phone jack J2 are mounted on the panel itself. A piece of copper screen or perforated phenolic board should be placed in front of the speaker.

R1 is included in the specified neon-lamp assembly. If you use a neon lamp other than the type specified (without an accompanying resistor), be sure to add R1. R3's ground connection is made with the ground strap supplied with the control. It may appear to be connected to the wrong side of R3, but this is correct in this application. Try to obtain a speaker with a bracket for T2.

T2's wiring as shown permits high-impedance phones (2,000 ohms or more) to be connected directly to the receiver output. If you want to use low-impedance phones, J2 must be wired as shown in the separate schematic.

Power transformer T1 is a special type made for Command Receiver conversions. No instructions are supplied with it so follow the color coding shown in the pictorial and schematic. The CCC uses silicon power rectifiers, so tape the unused 5-volt white leads.

Operation. Command Receivers are designed to have a dynamotor mounted on the rear apron, and they have three banana plugs (to carry B+ and filament power) to connect to the dynamotor. Since the CCC is connected to the accessory socket on the rear of the receiver, the exposed hot banana plugs must be taped as a safety precaution.

Connect P1 to the CCC, P2 to the

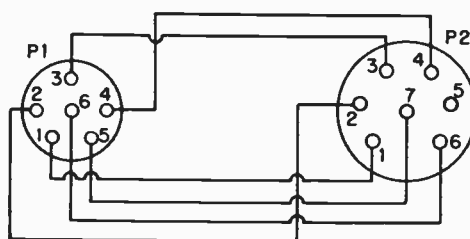

POWER CABLE: P2 PLUGS INTO SOCKET ON REAR APRON OF RECEIVER

A 6-pole rotary switch can be used to connect several Command receivers (P2) to a CCC (P1).

receiver and set BFO switch S3 and standby switch S2 to off. Turn on power with the switch on R3. After warmup, set S2 to on. As you advance R3 there should be a rushing sound. If there isn't, check the power cable connections.

Command receivers require a long-wire antenna. On the front panel of the receiver is a control marked *align input*. Adjust the setting of this control for maximum signal or noise. If you want to copy code, set S3 to on. Though the BFO's frequency is preset, it can be changed. On the right side of the receiver there is a small hole behind which is a screwdriver-adjust control which changes the BFO's frequency. Tune in a signal and use a thin-blade screwdriver (it need not be insulated) to turn the screw.

Command receivers can be converted easily to operate at other frequencies and one model, the BC-453 makes a fine Q5er. A Q5er can give a budget receiver the selectivity of a receiver costing several hundred dollars. After you have used the Command Receivers and experimented with them, you may want to make some other conversions or soups-ups. The CCC will make the job much easier. Since you already have the receiver working, you'll be digging into something you're familiar with. Both the schematic for the Command Receivers and descriptions of virtually every use and conversion for them can be found in the Surplus Conversion Manuals, Volumes 1, 2 and 3.

New Model 161 UTILITY TESTER[®] FOR REPAIRING ALL ELECTRICAL APPLIANCES MOTORS • AUTOMOBILES • TV TUBES

As an electrical trouble shooter the Model 161:



- Will test Toasters, Irons, Brailers, Heating Pads, Clocks, Fans, Vacuum Cleaners, Refrigerators, Lamps, Fluorescents, Switches, Thermostats, etc.
- Will test all TV tubes (including picture tubes) for open filaments and burned out tubes.
- Measures A.C. and D.C. Voltages, (Both 110 Volt and 220 Volt lines).
- Will measure current consumption (amperes) while the appliance under test is in operation.
- Incorporates a sensitive direct-reading resistance range which will measure all resistances commonly used in electrical appliances, motors, etc.

As an Automotive Tester the Model 161 will test:

- Both 6 Volt and 12 Volt Storage Batteries • Generators • Starters • Distributors • Ignition Coils • Regulators • Relays • Circuit Breakers • Cigarette Lighters • Stop Lights • Condensers • Directional Signal Systems • All Lamps and Bulbs • Fuses • Heating Systems • Horns • Also will locate poor grounds, breaks in wiring, poor connections, etc.

IT'S SO EASY!!



with tester's cord in outlet, current consumption of appliance is read direct on meter when line cord is connected to receptacle on panel. This typical iron takes 7 amperes (Good).



Simply insert tube in appropriate socket then follow procedure as outlined in our manual.



Control circuits of most furnaces use 24 volts obtained from step-down transformer. Here's how to check room thermostat to see if wires to it are live.



Small electric fan motor indicates 50 ohms (normal resistance).



Test Generators
READ THIS!



Test Storage Batteries
READ THIS!



Test Circuit Breakers
READ THIS!



INCLUDED FREE!!

This 56-page-book—practically a condensed course in electricity. Learn by doing.

Just read the following partial list of contents:

- What is electricity? • Simplified version of Ohms Law • What is wattage? • Simplified wattage charts • How to measure voltage, current, resistance and leakage • How to test all electrical appliances and motors using a simplified trouble-shooting technique.
- How to test all TV tubes; also simple procedure for determining which specific tube (or tubes) is causing the trouble.
- How to trace trouble in the electrical circuits and parts in automobiles and trucks.

Model 161 comes complete with above book and test leads. Only **\$22⁵⁰**

You don't pay for the Model 161 until AFTER you have examined it in the privacy of your home!

SEND NO MONEY WITH ORDER PAY POSTMAN NOTHING ON DELIVERY

Try it for 10 days before you buy. If completely satisfied then send \$5.00 and pay the balance at the rate of \$5.00 per month until the total price of \$22.50 (plus small P.P. and budget charge) is paid. If not completely satisfied, return to us, no explanation necessary.

ACCURATE INSTRUMENT CO., Inc.
Dept. D-315, 911 Faile St., Bronx 59, N. Y.

Please rush me one Model 161. If satisfactory I agree to pay \$5.00 within 10 days and balance at rate of \$5 per month until total price of \$22.50 (plus small P.P. and budget charge) is paid. If not satisfactory, I may return for cancellation of account.

Name _____
Address _____
City _____ Zone _____ State _____

the Stereo 120

120 watts of the cleanest sound this side of the concert hall.

By Harry Kolbe

DROP into your hi-fi dealer's showroom or take a look through a hi-fi catalog and you're going to reach one conclusion: the transistor stereo amplifier has arrived. Right out front with the best going is EI's Stereo 120—a solid-state stereo power amplifier with awe-producing specs you'll find hard to match. Just look at them: both channels can deliver 60 watts of 1,000 cps sine-wave power simultaneously to 8-ohm loads. The sensitivity is 200 rms millivolts for full output. Frequency response at 1 and 55 watts is flat within 1db from 5 cps (limit of test instruments) to 50 kc. Total harmonic distortion at both 1,000 cps and 20 kc is 0.75 per cent at 1 watt and 0.6 per cent at 55 watts. IM (intermodulation) distortion is below 1 per cent at rated power (60 cps and 7 kc, 4:1). Since the Stereo 120's input impedance is 400,000 ohms, it can be driven by a vacuum-tube preamp

Other outstanding features include excellent transient response, a damping factor that is uniform over the audio spectrum (fuse F2, F3), protection for the output transistors against switching transients and circuit-breaker protection of the output transistors against overdrive or shorted output terminals. Diodes mounted in the base plate (which serves as a heat sink for the output transistors) compensate for temperature rise of the output transistors.

We strongly caution against making

any changes in the power supply circuit since the power supply in The Stereo 120 has two important features: 1) heavy filtering, 2) protection for the output transistors. Using another power supply with tighter regulation could cause the output transistors to be damaged if overdriven.

You have your choice of building a mono or stereo version. EI has arranged for the author to supply a kit of parts which includes the transformers, matched power transistors and fast-acting fuses (F2, F3—see Parts List).

There are two reasons why we arranged for the author to supply a partial kit of parts. First of all, the power and driver transformers are of special design and cannot be obtained from parts distributors. Secondly, the betas of certain transistors which are starred (*) in the Parts List must be matched in order for The Stereo 120 to meet its stated specifications. While the transistors are available on the open market, their betas are likely to differ somewhat. In addition, if the transistors and transformers were purchased on the open market, they would cost you considerably more than the price stated in the Parts List.

Construction. Don't feel that the construction of a high-power transistor stereo amplifier is going to be a difficult undertaking. The Stereo 120's layout and component selection were made

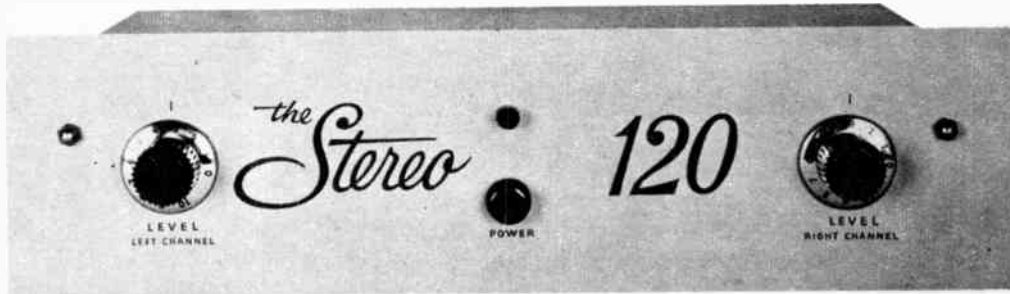

PARTS LIST		
Resistors: 1/2 watt, 10% unless otherwise indicated		
R1, R2—27,000 ohms	R30—68 ohms	
R3, R12—47,000 ohms	R31—100,000 ohms	
R4—5,600 ohms	Capacitors: All electrolytic unless otherwise indicated	
R5—10,000 ohm, logarithmic-taper potentiometer	C1—2 mf, 25 V	C2—50 mf, 10 V
R6—6,800 ohms	R7, R27—18,000 ohms	C3—50 mf, 25 V
R8, R9—10,000 ohms	R10—330 ohms, 2 watts	C4—50 mf, 3 V
R10—330 ohms, 2 watts	R11—330 ohms	C5—42 mmf, 500 V ceramic disc
R13—220 ohms	R14—180 ohms	C6—100 mf, 15 V
R15—3,300 ohms	R16—270 ohms, 2 watts	C7—500 mf, 3 V
R17—6.8 ohms, 1 watt, 5%	R18—150 ohms, 2 watts, 5%	C8, C9, C10—200 mf, 15 V
R19—120 ohms, 1 watt, 5%	R20, R24—100 ohms, 1 watt, 5%	C11—C14—500 mf, 50 V
R21, R23—240 ohms, 2 watts, 5%	R22, R26—.51 ohms, 1 watt, 5% (or two 1-ohm, 1/2-watt resistors in parallel)	C15—50 mf, 50 V
R25—120 ohms, 2 watts, 5%	R28—82,000 ohms	D1—1N2858 diode (RCA)
R29—470 ohms		D2, D3—1N2326 diode (RCA)
		S1—SR4—750 ma, 400 PIV silicon diode (Lafayette SP-241 or equiv.)
		CBI—Thermal circuit breaker, Sylvania MB-315 (Allied Radio Industrial Catalog Part # 34 B 075, 25¢ plus postage)
		Q1, Q2—2N2374 transistor (Philco) or 2N2614 (RCA)
		Q3, Q9—2N2374 transistor (Philco) or 2N591 (RCA)
		Q4, Q5, Q7, Q10—2N2148 transistor (RCA)
		*Q6, Q8—2N2147 transistor (RCA)
		S1—SPST toggle switch
		NL1—NE-51 neon lamp and holder
		F1—2 A fuse and holder
		F2, F3—GBB-1/4 Bussmann fuses
		*T1—99P10 power transformer (special)
		*T2—99A10 driver transformer (special)
		J1—Phono jack
		Misc. — Motorola MK-15 power-transistor mounting kit, silicone grease, terminal strips, 10x14x3-inch aluminum chassis, fuse holders for S1-SR4 (Lafayette EL-374)
		*Starred parts are available in a kit from Harry Koibe, P. O. Box 3, Cooper Station, New York 3, N. Y. (\$40 for stereo, \$30 for mono. Postage extra.)

Fig. 2—Since left and right channels are the same, circuit for only one channel is shown. Output transistors and the power supply are protected from overload by circuit breakers CB1 and by fuses F2 and F3.

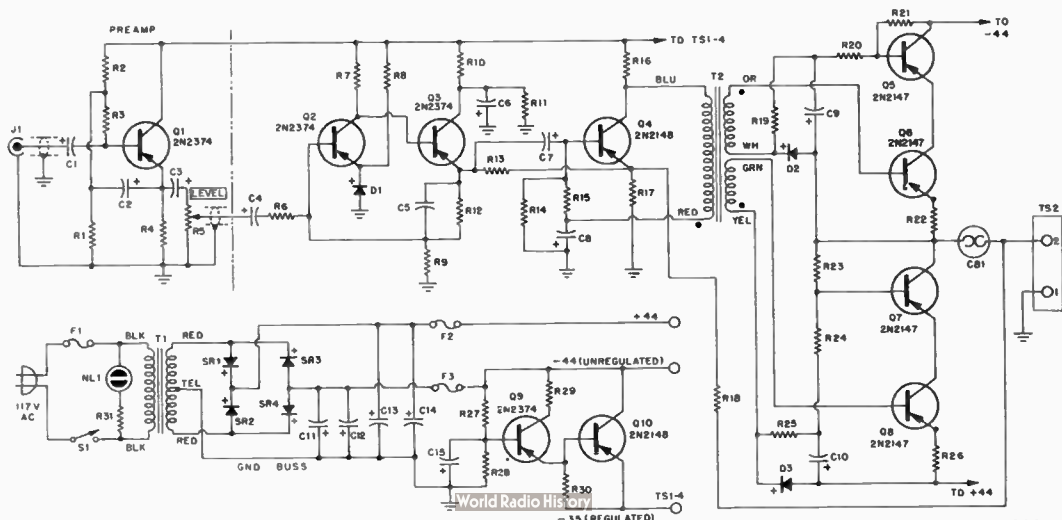

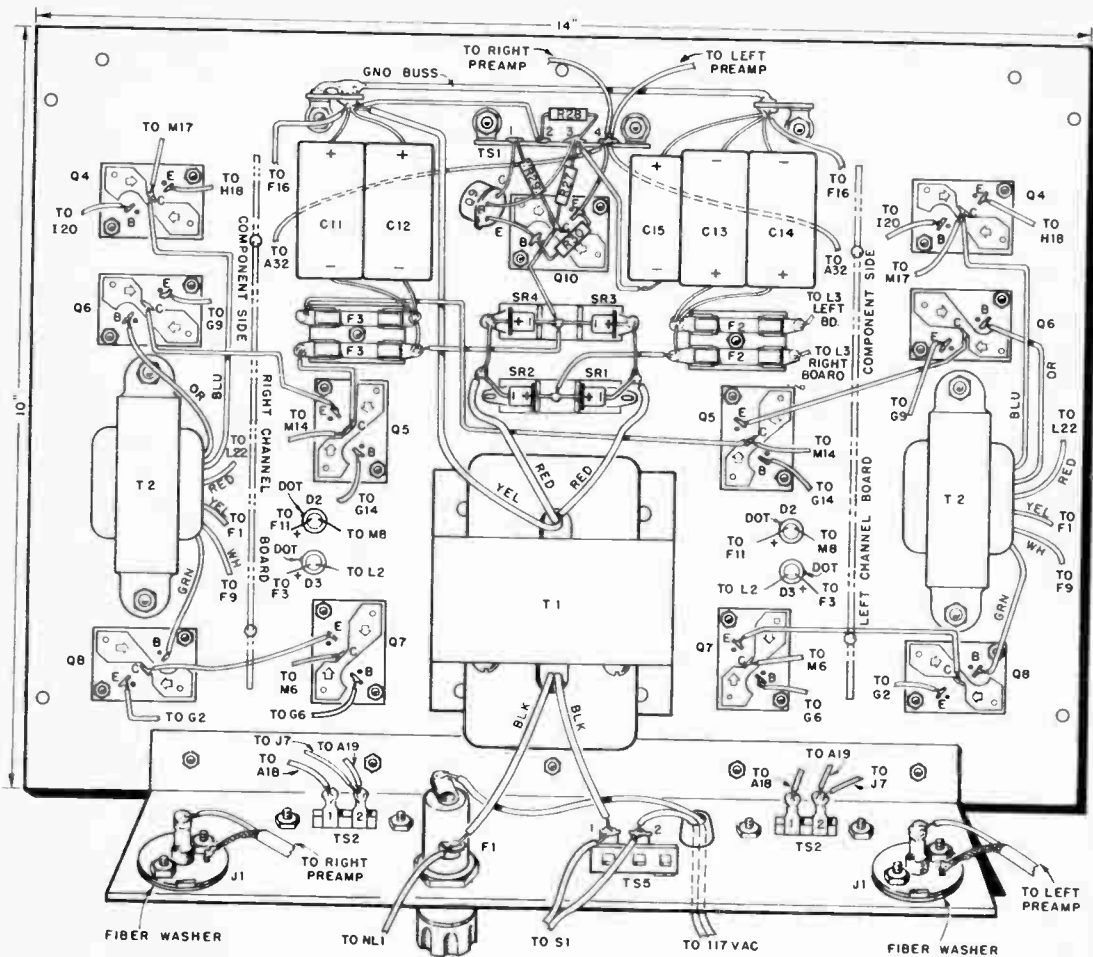

Fig. 3—Parts and their position are drawn to scale. To prepare base plate, take dimensions from here and multiply by 2.5 for full-size layout. Or, have this drawing photostated up to 10x14 inches for template. Do not solder SR1's and SR2's anode (-) leads and T1's red leads to the solder lugs on fuse holder.

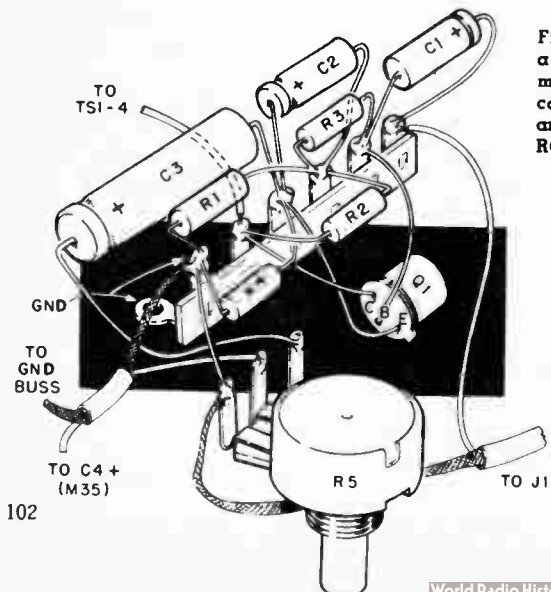
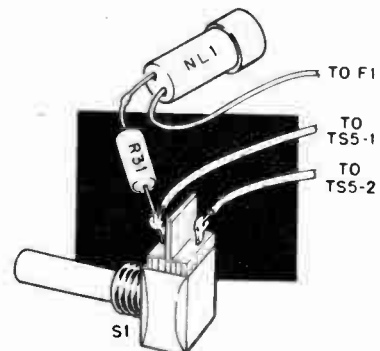

Fig. 4—Preamp (left) components are mounted on a six-lug terminal strip and, with R5, are mounted on the inside of the chassis cover. Note common-ground point for shields of wires to C4 and J1. Shielded cable to and from preamps is RG174/U. Power switch and pilot lamp are below.





FOR HAM RADIO—
Heathkit 40 Watt SSB Transceiver, Kit HW-12, \$119.95

FOR SPORTS—
Heathkit 10 Watt Walkie-Talkie Kit GW-52 \$74.95



FOR STEREO/HI-FI—Heathkit 40 Watt Hi-Fi Stereo Amplifier, Kit AA-21 \$19.95

Here are a few Heathkit values...

FOR YOUR BOAT—
Heathkit 25 Watt Radio Receiver, Kit MBW-13 \$164.95



FOR COLOR TV—
Heathkit CR-11 \$119.00



there are 245 more where these came from

FOR TEST EQUIPMENT—
Heathkit "Service Bench" VTVM, Kit IM-13, \$12.95



FOR YOUR HOME—
Heathkit Electronic Organ, Kit OD-212, \$149.95



Heathkit . . . world's largest electronic kit line—
now bigger and better than ever!

Kit builders will find savings of up to 50%, and a selection of over 250 kits behind our catalog cover.

Each kit is backed by over 30 years of kit building experience, and comes complete, right down to an easy to follow instruction manual that will enable you to build the kit of your choice in a matter of hours, without experience! If you've built a Heathkit in the past 2 years, you'll receive your FREE copy of the new Heathkit catalog automatically! If you haven't already gotten the Heathkit habit, now's the time to find out why Heathkit building is becoming America's most popular pastime.



HEATH COMPANY 112-4-1
Benton Harbor, Michigan 49023

Please send Free Heathkit Catalog.

Name _____ (please print)

Address _____

City _____ State _____ Zip No. _____

CL-170

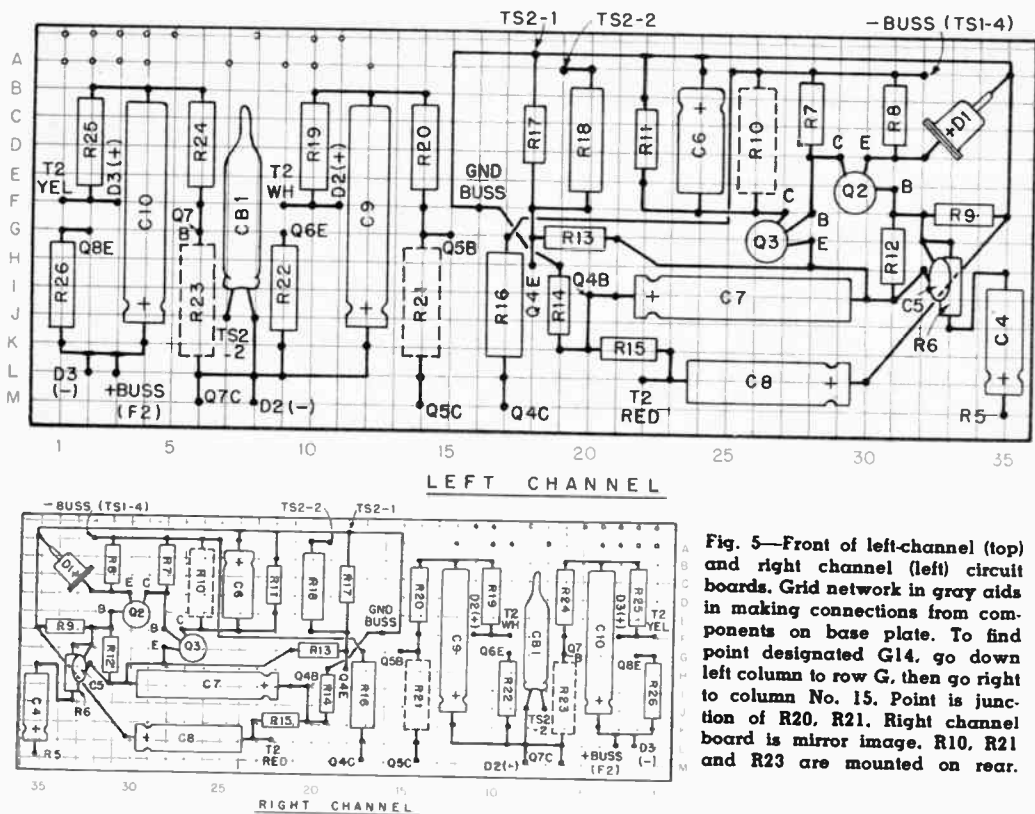

Fig. 5—Front of left-channel (top) and right channel (left) circuit boards. Grid network in gray aids in making connections from components on base plate. To find point designated G14, go down left column to row G, then go right to column No. 15. Point is junction of R20, R21. Right channel board is mirror image. R10, R21 and R23 are mounted on rear.

with an eye toward simplifying things. If three rules are carefully adhered to you should not run into any problems.

Rule 1: Be neat and take your time; this is not a project to break speed records. Dress all wires as shown in pictorials.

Rule 2: Check and double check each connection against the pictorials and schematic. After completing a major section, such as a circuit board or the power supply, check it again. And after the entire job is completed, check it from beginning to end.

Rule 3: Don't make any modifications or parts substitutions. This means use the part values and tolerances specified in the Parts List. Some latitude is permitted, but only if you have the electronic know-how to realize the consequences of what you are doing.

The first and most tedious job is laying out and drilling the base plate. The base plate is a 10x14x $\frac{1}{8}$ -inch thick piece of aluminum (alloy 2024-T3). It *must* be this thick as it serves as a heat sink for the power transistors that are mounted on it. We recommend you have

the plate cut to size where you buy it. The low minimum cutting charge is well worth it as it is not easy to cut $\frac{1}{8}$ aluminum with a hacksaw.

Using a T-square, steel ruler and a sharp scribe, rule guide lines for the eleven power-transistor sockets. The Motorola MK-15 transistor socket kits are supplied with two adhesive-backed drilling templates. One is for the bottom of a chassis and the other is for the top of a chassis. The top of the base plate corresponds to the *bottom* of a chassis, so use the template marked *back of chassis*. Orient the templates on the *top* of the base plate as shown in Fig. 3.

Scribe hole centers for T1, T2, D2, D3, TS1; also both of the ground-buss terminal strips, the rear bracket, the chassis cover, the two fuse holders for SR1-SR4 and the two circuit boards. When you have finished marking the base plate there should be (including six holes for each of the 11 transistor sockets) exactly 102 hole centers. The list following shows the number of holes required and their sizes.

Learn ELECTRONICS in Classrooms and Labs of COYNE ELECTRONICS INSTITUTE

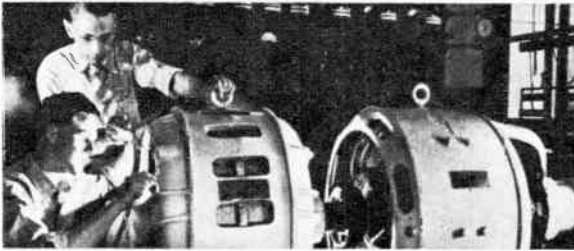

ELECTRICITY-ELECTRONICS: Motors, Generators, Computer Circuitry, Appliances, Automatic Electronic Control Units, Refrigeration and Air Conditioning.

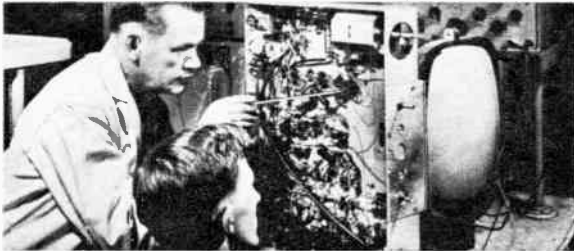

TELEVISION-ELECTRONICS: TV Receivers—Black and White and Color AM-FM and Auto Radios, Transistors, Printed Circuits Test Equipment, Closed Circuit TV.

Now is the time to train for a top-pay job in electronics. When you train at Coyne, you work on the same type of equipment you will work on outside in industry. You will be getting your training at one of the largest and best equipped schools in the country. During the past 65 years, we have put thousands of ambitious men on the road to security and personal independence in the fast-growing field of Electronics. No previous experience needed. No advanced education required.

START NOW—PAY LATER. Liberal Finance and Payment Plans. Part-time employment help for students. Mail coupon now for **FREE** copy of "Your Opportunities in Electronics." *No salesman will visit.* Send coupon, postcard or letter right away . . . before you forget.

MAIL COUPON OR WRITE TO ADDRESS BELOW

- COYNE ELECTRONICS INSTITUTE*
- Dept. 54-B
- 1501 W. Congress Pkwy., Chicago, Ill. 60607

• Name _____

• Address _____

• City _____ State _____

• Age _____ Phone _____

*Chartered as an Educational Institution Not for Profit



COYNE offers
LOW COST
TELEVISION
RADIO - COLOR TV
 Training in
 Spare Time **AT HOME**



—PLUS Two Weeks Personal Training in our Chicago Shop-Labs—FREE of any extra Tuition!

Coyne—and only Coyne—can make you such a sensational offer. No increase in cost of home training, but as soon as you graduate you are qualified to spend two weeks in Chicago, working on actual projects, getting personal instruction—with-out one cent of extra tuition. Like getting a post-graduate course free. This offer may be withdrawn at any time, but those who inquire about Coyne's home training now will be guaranteed two weeks of shop training at Coyne's expense for resident tuition. Send name for **FREE BOOK**.

Now, you can quit *wishing* you had a profitable Radio-TV Service Business of your own. Now, you can quit *dreaming* about a big pay job in Television—and *do something* to make your dreams come true. Start your basic training at home in spare time. We train you to do the work, and show you how to get the work to do—even while you are learning. No costly "put together" kits to pay for. Lowest tuition—low monthly payments. Free employment service to graduates. Send name for all facts. No salesman will call.

Send Name for FREE BOOK. No salesman will call



COYNE ELECTRONICS INSTITUTE

Chartered as an Educational Institution Not For Profit
 1501 West Congress Parkway, Dept. 54-B9, Chicago 60607

COYNE ELECTRONICS INSTITUTE
 HOME TRAINING DIVISION, Dept. 54-B9
 1501 W. Congress, Chicago 60607

Please mail free book and offer of two weeks personal training in Chicago without extra tuition for home study graduates. Explain low monthly payments.

Name _____

Address _____

City & State _____

the Stereo 120

Power transformer T1—4 #10 holes
Driver transformer T2—4 #18 holes
Rear bracket—5 #28 holes
Left- and right-channel circuit boards—2 #18 holes each
SR1-SR4 holders—1 #18 hole each
Terminal strip TS1—2 #28 holes
F2 and F3 fuse holders—1 #18 hole each
Cover—7 #28 holes
Ground-buss terminal strips—1 #18 hole each
Diodes D2, D3—4 holes (see text)

The number and size of the holes for the power-transistor sockets are stated on the drilling templates.

Base-plate drilling requires great care. The transistor socket holes must be drilled carefully or the transistor pins may short to the base plate. Use a sharp center-punch—do not hit it too hard or it will slip—to start the holes. The best way to drill the holes with home-workshop equipment is to start them with a small pilot drill. Drill D2's and D3's holes slightly smaller than the diameter (0.240 inch) of their case—more about these holes later.

After all holes have been drilled, deburr them, polish with emery cloth, and wash both sides of the base plate with scouring powder. Rinse the plate, dry

with a clean cloth and wrap it for later use.

The rear bracket is a 10¾-inch long by 2x2-inch aluminum angle bracket from one leg of which you must cut 1¼ inches. Lay out, center-punch and drill holes for TS2 (2) TS5, F1, J1 (2) and the line cord on it. The holes for J1 (2) must be large enough so a phono plug's outer shell won't touch the bracket. Set the bracket aside until later.

The left- and right-channel circuit boards are 6¾x2½-inch pieces of perforated phenolic board 15 rows high and 36 columns long (Lafayette stock number MS-305).

Except for R10, R21 and R23, all the components are mounted on the side of the board facing you (Fig. 5). Push component leads through the holes and bend them in the directions shown. (Use spaghetti on all leads that cross each other.) The black lines in Fig. 5 are on the reverse side of the board. R10, R21, and R22 must be mounted ¼ inch away from the reverse side of the board. Mount Q2 and Q3 ½ inch away from the board on the side facing you.

Connect wires to the points on the circuit boards indicated in Fig. 5 (Q4B, Q6E, for example). Tag each lead with small adhesive label. The only leads you cannot connect at this time are T2 yel, wh, red; D3 (+, -); D2 (+, -) and C3 (+). Install two #6 spade lugs on the bottom of each circuit board.

Unwrap the base plate now, and keep it as clean as possible. Mount the 11

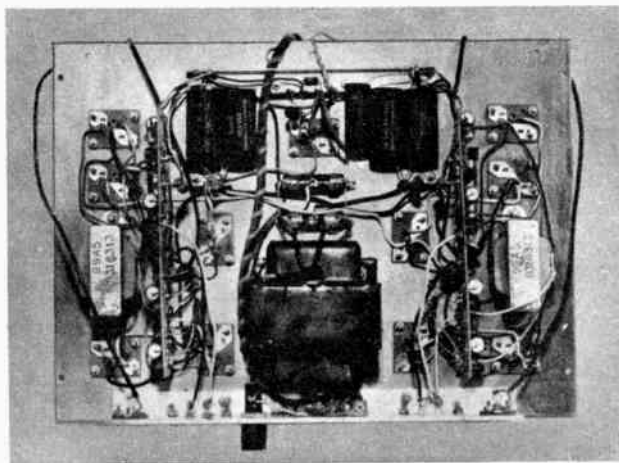

Fig. 6—Top view of amplifier. Left- and right-channel component layouts are mirror images of each other. Heavy line, top center, is ground buss made of #16 wire. Make all connections between base-mounted transistors, terminal strips and rear panel before installing left- and right-channel circuit boards in place. Be very careful when connecting the speaker leads to the output terminal strips. A frayed piece of wire shorting the terminals could damage or possibly destroy output transistors.

Take this big 196-page "Fix-it" book

FREE!

Yes, entirely FREE — and packed with plans, projects and ideas for make-it-yourself fun, ways to

save money by making home improvements and car tune-ups and repairs yourself, often doing them better than "high-priced" outside help and far easier than you might think.

How to have Vol. I shipped FREE immediately:

Fill out and mail shipping label below today. We'll send Vol. I right away FREE. Do not send it back or pay anything for it ever. Large 7½" x 11" book is typical of all 18 volumes in Practical Handyman's Encyclopedia. 3,456 pages, 7,000 show-how pictures, thousands of ideas and projects: gardening, furniture, plumbing, electrical, hi-fi, electronics... boats... cabins, cottages... photography... built-ins, kitchens, bath... concrete... etc.

After examining Vol. I, you may receive further volumes as they become ready. Examine each 7 days, then either remit only \$2.98 plus postage or return book, owe nothing. Buy one, two, as many books as you like... or whole set... or none at all. No pressure; no "catches". We stop sending books any time you write us.

Send shipping label now for FREE VOLUME I to: Practical Handyman's Encyclopedia, Dept. EH4, Box 77, Cos Cob, Conn.

PRACTICAL HANDYMAN'S ENCYCLOPEDIA

ACTUAL SIZE
7½" x 11"

ALL This and More in
Your FREE Book:

- ADDITIONAL BEDROOM
- BUILT-IN CLOSETS
- MODERN FURNITURE
- TV REPAIRS
- ANTENNA PROBLEMS
- HOME VENTILATION
- BURGLAR ALARMS
- ALUMINUM PROJECTS
- ATTIC EXPANSION
- HOUSE FRAMING
- GARDEN ACCESSORIES
- BOOSTING GAS MILEAGE
- WINDOW FRAMING
- SKYLIGHTS
- PLYWOOD PROJECTS
- POWER TOOLS
- AIR CONDITIONING
- HOME AND CAR
- TRANSMISSIONS
- DRIVE SHAFTS,
- AND DIFFERENTIALS
- SPRAY PAINTING
- OUTDOOR FURNITURE
- WEBBING
- DORMERS
- WEATHERPROOFING
- ATTIC FANS
- BAR CART
- PATIOS
- BARBECUES
- EMERGENCY
- CAR REPAIRS
- AUTO TUNE-UPS
- STARTING PROBLEMS
- CAR COOLING SYSTEM
- ROOFING
- SHEATHING
- APPLIANCE
- REPAIRS
- GUTTERS
- & FLASHING

WHY DO WE GIVE AWAY THIS LARGE VOLUME—containing over 100 projects, 400 how-to pictures, 50,000 words—without "strings" To demonstrate to home owners and hobbyists the dollars-and-cents value of our famous "how-to" Encyclopedia.

Which project do you want to start right away?

Want an extra room? Air condition your home? Trouble-free your TV antenna forever? Car tune-up, gas-saving tips? Build bar cart? Barbecue? Attic ventilator? Modern arm-chair? Free Volume I's experts guide your hands with clear photos... insiders' secrets... diagrams... checklists. Even beginners can't go wrong, waste time or materials. Save \$2.50—\$4.96 **HOURLY LABOR — DO CRAFTSMANSHIP JOBS!** Now even amateurs can handle "skilled" jobs. Save \$9 TV house calls. \$4.25 carpenters' hourly rate. Big car mechanics' bills.

SHIPPING LABEL

FROM: The Practical Handyman's Encyclopedia
Box 77, Cos Cob, Conn.

TO:

Name _____ (please print)

Address _____

City _____ Zone _____ State _____

CONTENTS: BOOK. Volume I of The Practical Handyman's Encyclopedia. 1¾ lbs., 196 pages, over 400 pictures, 55,000 words.

NO RISK NO OBLIGATION. WHAT YOU GET:

1. FREE 196-page, over 400-picture, over 100-project Volume I of The Practical Handyman's Encyclopedia. No cost at any time, no "catch," no obligation.
2. You are entitled to receive each new volume for 7 days' free approval. For those you decide to keep, you pay only \$2.98 plus shipping.
3. You never have to buy any books at all... or you can choose one or a few... or the complete matched Library set, if you wish... the choice is yours.
4. You may instruct us to stop shipping books simply by writing us and we'll cease shipping immediately.

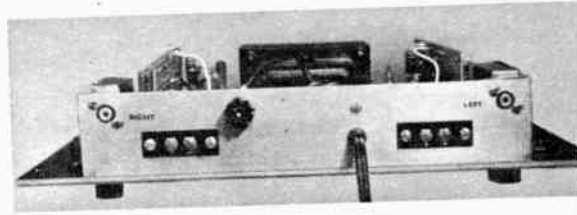
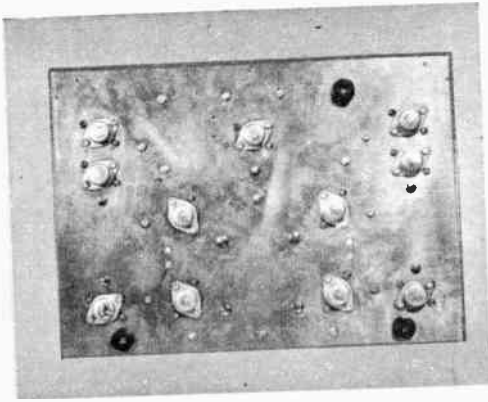

Fig. 7—Rear of amplifier (top). Note size of holes that must be drilled for input jacks so shell of plug will not touch panel. Underside of amplifier (left). Going from top to bottom, left column (3 transistors) to right, transistors are Q4, Q6, Q8, Q5, Q7, Q10, Q5, Q7, Q4, Q6 and Q8. Mounting feet should be at least 1/2 inch high for ventilation.

power transistor sockets with 6-32 round head (small head) screws. Also mount the two ground-buss terminal strips, TS1, and F2's and F3's fuse holders. Install the #16 ground-buss wire, Q9, R27, R28, R29, R30, C11-C15 SR1-SR4 as shown in Fig. 3.

Very carefully enlarge the holes for diodes D2 and D3 with a tapered hand reamer. The holes must be large enough so that moderate pressure will push the diodes into the hole for a snug fit. Push them into the holes from the top just far enough so they are flush with the bottom of the base plate.

Connect wires between Q7E and Q8C and between Q5E and Q6C. Mount T1 with 10-32 screws. Connect T1's red and yellow leads.

Mount the circuit boards and connect the leads from them to the base plate components. Connect the leads from D2, and D3 to the circuit boards, then mount and then connect both the driver transformers.

Turn the base plate over—it will rest safely on the top of T1 and the circuit boards. Install the 11 power transistors as follows: In each of the sockets' corner holes put a white plastic insulating bushing. (Plastic bushings, a mica washer and mounting screws are supplied in the Motorola MK-15 transistor mounting kit.) Carefully apply a small amount of silicone grease to both sides of the mica insulating washer and position it on the base plate. Plug the transistor in and secure it taking care not to strip the mounting threads on the socket.

On the rear bracket, mount F1, TS5, the input jacks and the speaker terminal strips. Fasten the bracket to the base plate with five 6-32 screws. Install the line cord and connect it to TS5 and F1.

The last construction step is the cover and the preamps. The cover is made from a 10x14x3-inch aluminum chassis. On one long side drill holes for the level controls, power switch, pilot lamp and preamp terminal strips.

On the other long side of the chassis, cut out a 10 1/4 x 1 7/8-inch section, as shown in Fig. 1, to clear the rear bracket. Mount six-lug terminal strips near the level controls and build the preamps using the layout in Fig. 4. For now, do not connect the leads to and from the preamps.

Checkout. Before turning on power you must make resistance measure-

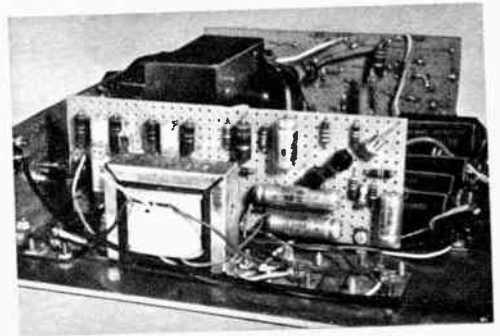

Fig. 8—Left-channel board. Driver transformer T2 (foreground) in author's model is unshielded. Transformer in parts kit will be in metal case.

ments in the output stage. This will prevent destroying the output transistors because of a wiring error. But before making the measurements it is necessary to determine the polarity of the test leads of your VOM or VTVM.

The following simple test will quickly indicate the lead polarity: 1) Select a 2N2148 power transistor and position it with the pins facing you (note that the pins are off center) and above the horizontal center line of the transistor. In this position the left pin is the base and the right pin is the emitter. 2) Connect the negative test lead of the VOM or VTVM to the metal case (collector) of the transistor and the positive test lead to the base pin. Switch the ohmmeter to the Rx10 or Rx100 scale. Note the resistance. 3) Reverse the test leads, connecting the negative one to the base pin and the positive test lead to the case. Note the reading. 4) If you obtained a much lower resistance with the positive test lead connected to the base pin, consider this test lead negative. 5) If you obtained a much lower resistance reading with the negative test lead connected to the base pin, the ohmmeter test leads' polarity is correct.

Connect the negative test lead to the chassis and connect the positive test lead to the points specified below. A variation greater than 20% from the values given indicates a wiring error or defective output transistor.

Transistor	Resistance to ground (ohms)		
	Emitter	Base	Collector
Q5	410	500	260
Q6	210	160	150
Q7	380	460	290
Q8	670	670	380

If all resistances are correct, connect the leads to and from the preamps, power switch, and pilot light to the circuit boards and base mounted components. Carefully install the cover.

The output impedance of the Stereo 120 is 8 ohms. If your speakers' impedance is 4 ohms, install a 4-ohm, 20 watt resistor in series with one of the speaker leads. Sixteen-ohm speakers can be connected directly to the output terminals.

FREE!

LAFAYETTE

RADIO

ELECTRONICS

1964 CATALOG

NO. 640



**422
GIANT-
SIZE
PAGES**

LAFAYETTE GIVES YOU MORE IN '64

- ✓ **MORE CATALOG**—it's the biggest in our 43-year history; 422 giant-size illustrated pages.
- ✓ **MORE SELECTION**—if it's in hi-fi or electronics, it's at Lafayette... tape recorders, C.B., hi-fi stereo, ham gear, test equipment, tools, radios, cameras—more than ever before.
- ✓ **MORE SERVICE**—more and more orders fully processed in 24 hours.
- ✓ **MORE BUYING POWER**—choose from Lafayette's three Easy-Pay credit plans. **NO MONEY DOWN, Up to 24 Months to Pay.**

43 Years of Dependable Service at Lafayette's Traditionally Low Prices from the "World's Hi-Fi & Electronics Shopping Center"

Mail the Coupon for Your FREE 1964 Lafayette Catalog

LAFAYETTE Radio ELECTRONICS
Dept. FEGD-4, P. O. Box 10
Syosset, L. I., N. Y.

Please send me the FREE 1964 422 giant-size page Lafayette catalog.

Name _____

Address _____

City _____ Zone _____ State _____

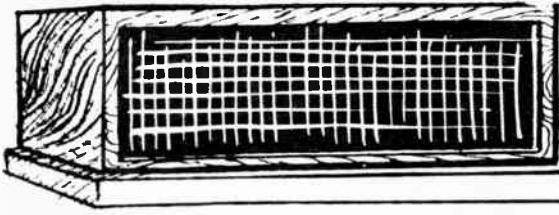

Stereo

ONE of the primary requirements for full stereo enjoyment is balance. The sound you hear from the left speaker must be at the same intensity as the sound you hear from the right speaker. Variations should occur only in the program you're listening to—not the system. Often you may juggle and re-juggle the amplifier's gain controls to achieve balance—only to find you have to go through the process again when you change your listening position.

EI's Stereo Balancer will aid in quickly setting your amplifier's volume controls for optimum sound balance, no

matter where you sit in the room.

The Balancer consists of an oscillator and a VU meter that can be connected to either the right or left speaker. The oscillator provides a *steady* signal, making balancing a snap. No longer do you have to adjust the amplifier's gain controls with a program whose level changes constantly. The Balancer's oscillator output level is set so even if your amplifier's gain control is turned up to normal, the neighbors won't be jarred off their chairs when you apply the signal.

The VU meter allows the level of each channel to be set for perfect balance. Or the VU meter can be used to produce exact *listening* balance when the channel levels must be different, such as when your speakers are of different efficiency or when your listening position is closer to one speaker than the other.

The oscillator is independent of the meter's speaker selector switch (S2). Its output is adjustable from zero to about 0.1 volt and it also can be used as a low-distortion signal source for

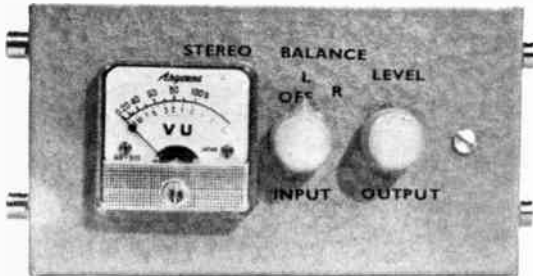

Input switch connects left or right speaker to meter. Output control sets level to amplifier.

PARTS LIST

- R1—50,000-ohm potentiometer
- R2, R3—4,700-ohm, 1/2-watt, 10% resistor
- R4—22,000-ohm, 1/2-watt, 10% resistor
- R5—3,600-ohm resistor (see text)
- C1—25 mf, 75 V capacitor (see text)
- C2—5 mf, 75 V capacitor (see text)
- C3—4 mf, 12 V electrolytic capacitor
- C4—30 mf, 12 V electrolytic capacitor
- L1—100 millihenry RF choke
- M1—VU meter (Lafayette TM-10 or equiv.)
- B1—9-volt battery
- J1, J4—phono jacks
- S1—SPST switch (on R1)
- S2—Two-pole, five-position rotary switch (Lafayette SW-78, see text)
- Misc.—Cabinet, terminal strip

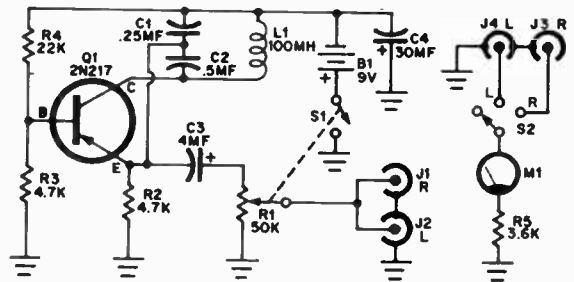

Colpitts oscillator operates at about 1,000 cps. Increasing the value of C1, C2 lowers frequency.

Balancer

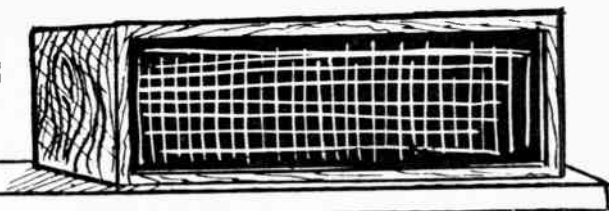

By Lawrence Glenn

troubleshooting your amplifier.

Construction. We built the Balancer on the main section of a $5\frac{1}{4} \times 3 \times 2\frac{1}{8}$ -inch Minibox. Special care when wiring is not required, other than to protect transistor Q1 and the low-power resistors from excessive heat when soldering.

Miniature components are used throughout to prevent a parts jam at the terminal strip. The specified C1 and C2 will produce a test frequency of about 1,000 cycles. C2 consists of two .25 mf capacitors connected in parallel. We did it this way because miniature .5 mf capacitors are hard to come by. If you prefer a test tone lower than 1,000 cycles, change C2 to 1 mf and C1 to .5 mf.

Q1 can be a 2N217 or a 2N109 transistor. By using R5, which is supplied with the meter, nearly full-scale readings will be obtained at low volume levels.

The VU meter is connected to either speaker by S2. S2, a two-circuit, five-position switch, was chosen only because of its small size and low cost. A single-pole, three-position or single-pole, cen-

ter-off switch may be substituted if desired.

Battery B1 is held on the side flange of the Minibox with a piece of hookup wire passed through a solder lug positioned on both sides. To prevent B1's terminals from shorting, put a piece of tape in the Minibox's cover opposite the battery connector.

Operation. Connect the Balancer to your amplifier as shown in the block diagram. Connect J1 and J2 to the right and left utility inputs, respectively (or you may use any other input). Connect J3 to the right-speaker output terminals and J4 to the left-speaker terminals. Set the amplifier's volume controls approxi-

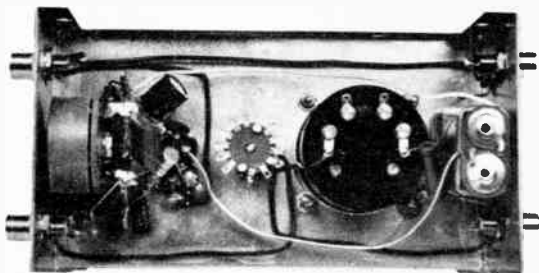

Connect components to terminal strip at left before mounting choke. Tape battery connector.

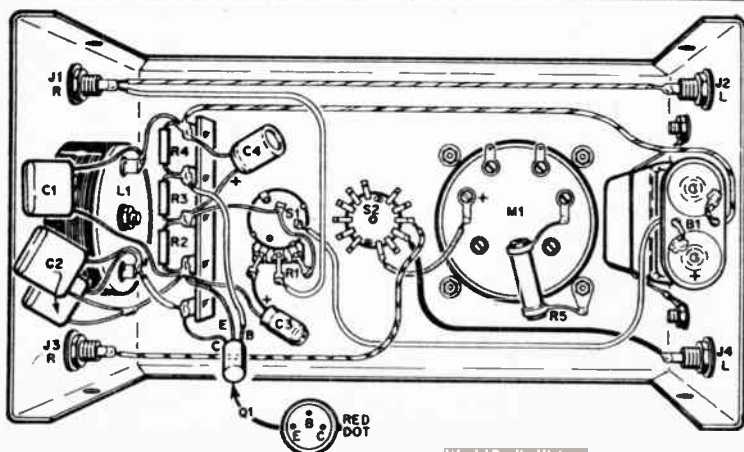

To save space, C2 is made up of two capacitors in parallel. Terminal-strip mounting lug, to which R2 and R3 are connected, is ground point. Unused lugs at top of meter are for built-in pilot lamps.

FREE Catalog

OF THE WORLD'S FINEST
ELECTRONIC GOV'T
SURPLUS BARGAINS



MOBILE AMPLIFIER

Used by the Navy for Intercom. Easily converted into a 5 Watt Mobile PA Amplifier. Uses 2/12A6 Tubes in Push-Pull; has Carbon Mic. & Radio Inputs and Headset Output. (Instructions supplied for converting to Speaker.) Voltage required for operation 12 VDC & 250 VDC 60 MA. With Instruction Book and one spare tube. Size: 7 1/2" x 7" x 10". Wt.: 15 lbs. #CMX-50126. Price, Less Dynamotor...



\$2.95

Price—With 12 Volt Dynamotor for Mobile **\$6.95**
Conversion Kit with Speaker Output, Transformer, Mic. & Phone Jacks, Switch and Cable with Plug for cigaret lighter; & Instructions **\$2.00**

HAND TYPE MAGNETO GENERATOR

Used for ringing telephone lines, output about 100 Volts. Also can be used as a shock machine—to light small bulbs, or drive worms out of lawn by placing output to metal stakes driven into ground.

GN-38 with 3 Horseshoe Magnets **\$2.95**
GN-38B Permanent Magnets—Magnet Size: 2" x 1" **3.95**
GN-41B Permanent Magnets—Magnet Size: 3" x 1 1/4" **4.95**
GN-38A with Coil Magnet **2.95**
G-25A Round Type Magneto **2.50**

Address Dept. EG • All Prices are F.O.B., Lima, Ohio • 25% Deposit on C.O.D. Orders. **SEND For FREE CATALOG!**

FAIR RADIO SALES
2133 ELIDA RD. • Box 1105 • LIMA, OHIO



*** FREE**

Fill in coupon for a FREE One Year Subscription to OLSON ELECTRONICS' Fantastic Bargain Packed Catalog—Unheard of LOW, LOW, WHOLESALE PRICES on Brand Name Speakers, Changers, Tubes, Tools, Stereo Amps, Tuners, C.B. and other Bargains.

NAME _____

ADDRESS _____

CITY _____ ZONE _____ STATE _____

If you have a friend interested in electronics send his name and address for a FREE subscription also.

OLSON ELECTRONICS
INCORPORATED

1006 S. Forge Street Akron, Ohio 44308

Stereo Balancer

mately to normal position and turn on the Balancer.

Set S2 to the *left* channel position and advance R1 until the meter indicates zero VU (100%). Then set S2 to the *right*-channel position and adjust the amplifier's right-channel volume control for zero VU indication. Your stereo system is now balanced (assuming your listening position is midway between the speakers).

If your normal listening position is not centered, you can program the Balancer for balanced sound where you sit.

If you sit closer to the right speaker, start with the right channel. Adjust the

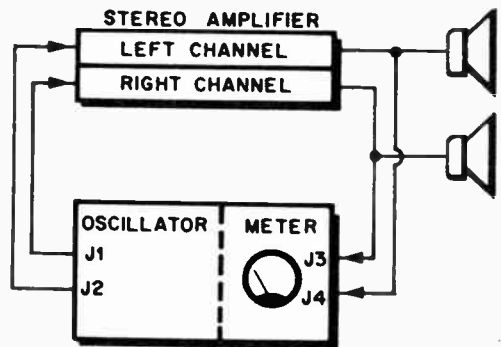

Block diagram shows the connections of the Balancer to inputs and outputs of stereo amplifier.

amplifier's right-channel volume control for a convenient meter reading—say 50%. Then set S2 to the left-channel position and have someone adjust the left-channel volume control until the sound seems (at the listening position) equal to the sound from the right speaker. The system is now balanced for off-center listening.

Note the meter reading of the left channel. It will be higher than 50%. From now on, whenever you want to balance the system for this listening position, just set the amplifier's controls to produce the same meter readings. This test can be programmed for any listening position in your room.

TRAIN AT HOME with NRI

For 50 years the leader in training men for careers in Electronics, Radio-TV

Training men to succeed in the many fields of Electronics has been NRI's only business for half a century. The NRI diploma is respected and recognized by prospective employers in business and industry throughout the U.S. and Canada. NRI graduates are enjoying higher pay, more interesting work, better futures in every field of Electronics . . . performing work for which you could qualify through NRI "learn-by-practice" methods. And NRI provides training at reason-

able cost because it is the oldest, largest home-study school of its kind. If you want the security, prestige and freedom from financial worries that come with training . . . then you want to investigate NRI's specialized instruction plans and the many career opportunities in the fast-growing Electronics industry. Write now for our two free books. Use the postage-free card below.

SEE OTHER SIDE

THE DEMAND IS GREAT FOR SKILLED TECHNICIANS



NRI's Servicing course trains you to fix black-and-white and color TV sets, radios, hi-fi, etc., shows you how to make \$3 to \$5 an hour in spare time soon after enrolling. Leads to a good full time business of your own, servicing Electronic products for the home.



Prepare for a career as an Electronic Technician in industry, business, government, the military, with NRI training in Industrial Electronics. Computers, telemetry, automation, etc. all employ the same basic electronic principles, and that is what NRI training stresses.

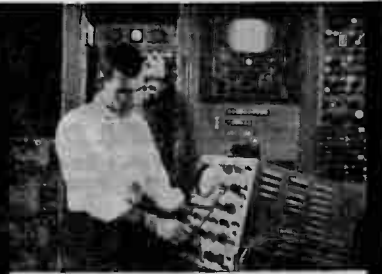

Communications offers a choice of careers operating or servicing transmitting equipment in broadcasting, aviation, marine, mobile radio, etc. From simple circuits to FCC exams, NRI courses train you quickly in one or all of the Communications fields.

**MAIL
POSTAGE
FREE
CARD FOR
2
NEW
BOOKS**

First Class
Permit
(Sec. 34.9, P.L. & R.)
Washington, D.C.
No. 20-R

BUSINESS REPLY MAIL

No Postage Stamp Necessary If Mailed In The United States

Postage Will Be Paid By



3939 Wisconsin Avenue
Washington, D.C. 20016

PICK YOUR CAREER

Join the thousands who gained success through NRI training

Thousands of ambitious men have moved up to career-level jobs or businesses of their own in Radio-TV Servicing, Communications, Industrial and Military Electronics through NRI training. The demand for skilled Technicians in this age of color TV, stereo, rockets, missiles, computers, telemetry, microwave, lasers, masers and automation is greater than the demand for engineers—4 to 7 times greater. Whether you're working in Electronics now, are a hobbyist or beginner . . . whether you're a college graduate or a man who had to leave school early . . . whatever your desire or education, there's Electronics training for you among NRI's specialized instruction plans. Choose from "short courses," specialized training in fields of Communications or intensive training for career positions. Get full details about the course of your choice without obligation. Mail card below.

1. Television-Radio Servicing
2. Industrial-Military Electronics
3. Complete Communications
4. FCC License
5. Basic Electronics
6. Math for Electronics
7. Aviation Communications
8. Marine Communications
9. Mobile Communications
10. Electronics for Automation

SPECIAL NRI EQUIPMENT MAKES TRAINING FASTER, EASIER

When you train with NRI, you "learn-by-doing" with carefully developed custom-designed equipment included—at no extra cost—with most courses. All equipment is yours to keep. Projects you build, experiments you perform, make NRI illustrated lessons come to life. Complex subjects take on practical meaning. Actual shop and laboratory experience makes learning faster, easier, makes you more valuable to prospective employers—or use it to make extra money in your own spare time or full time service business. Free books we send you show equipment, tell about the NRI Trial Enrollment Plan. Convenient monthly payments. Mail postage-free card.



SEE OTHER SIDE

MAIL FOR
2 NEW BOOKS

NO STAMP NECESSARY—NRI PAYS POSTAGE

NATIONAL RADIO INSTITUTE, WASHINGTON, D.C.
Please send me your two books about opportunities in Electronics-Automation, Radio-TV and your specialized instruction plans. (No salesman will call. Please print)

4 DE 6

Name.....Age.....

Address.....

City.....Zone.....State.....

ACCREDITED MEMBER NATIONAL HOME STUDY COUNCIL



NATIONAL RADIO INSTITUTE
WASHINGTON, D.C.
Oldest and largest school of its kind

