

**PROJECTS THAT EVERYONE CAN BUILD**

# **ELECTRONICS** **HOBBIYIST**

CC 02396

FALL-WINTER 1973 \$1.25

by the Editors of ELEMENTARY ELECTRONICS

## **Solder your way to Music!**

You can build this 12-note Music Box  
during 5 average banana breaks!

(See page 21)



### **Practical Projects**

- Action Band Portable • FM Mike • Speech Scrambler
- Super SCA Adaptor • BCB Booster • FET Timer •
- Disaster Alarm • Guitar Fuzz Booster • Auto Alarm
- Wireless Dew Detector • VHF-to-BCB Converter •
- and much, much more!!!

# SPECIAL INTRODUCTORY OFFER!

Now get **ELEMENTARY ELECTRONICS** sent to your home all year long for **ONLY \$2.67!** Order Now and Save!

\* \* \* For beginner or expert EE is valuable \* \* \*

Written by experts—you get a practical understanding of IC circuits . . . semi-conductors . . . power supplies . . . networks . . . transistors . . . pulse circuitry, much more! Get general rules

of electronics, develop trouble-shooting techniques, know how to calculate changing effects. **TRY THIS NO-RISK SUBSCRIPTION OFFER TODAY!**

**PROJECTS  
IN  
EVERY  
ISSUE**

•  
**CB  
RADIO**

•  
**SHORT-  
WAVE**

•  
**NEW  
PRODUCTS**

•  
**BASIC  
ELECTRONICS  
COURSE**

•  
**PRODUCT  
LAB  
TESTS**

## PUBLISHER'S DISCOUNT SAVINGS CERTIFICATE



Good **\$1.83** off the newsstand price of  
for **ELEMENTARY ELECTRONICS**



- Enter my trial subscription for 1 year (6 issues) of Elementary Electronics, for only \$2.67. (I save \$1.83 off the newsstand price.)
- I prefer 1½ years (9 issues) for \$3.97 (on the newsstand \$6.75).
- New Subscription       Renewal Subscription

Name \_\_\_\_\_  
(please print or type clearly)

Address \_\_\_\_\_

City \_\_\_\_\_ State \_\_\_\_\_ Zip \_\_\_\_\_

**SEND NO MONEY, WE'LL BILL YOU LATER**

You must seal (staple, scotch tape or glue) before mailing. Dept. B692

**FOLD HERE**



**BUSINESS REPLY MAIL**

First Class Permit No. 790 (Sec. 34.9 P. L. & R.) New York, N.Y.

**ELEMENTARY ELECTRONICS**

**P.O. Box 2600**

**Greenwich, Connecticut 06830**

**Dept. B692**

**CUT OUT  
AND MAIL  
TODAY!**





# FREE...demonstration lesson to prove that you can learn TV servicing at home.

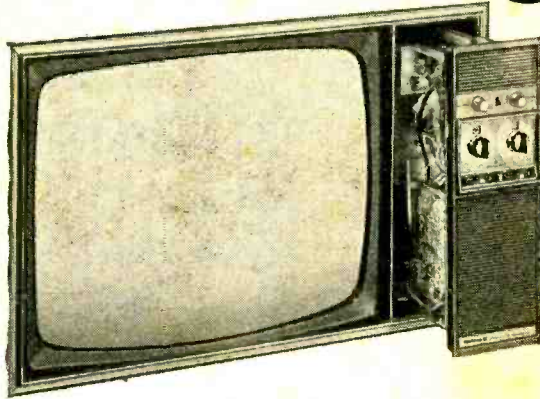

Practice on a new 25" MOTOROLA QUASAR II® chassis.

TV Servicing is a satisfying career . . . and the pay is great. Qualified men are needed now to maintain the 93 million sets in U.S. homes. And prospects for the future are even brighter.

Now . . . here's an opportunity for you to prove to yourself that **you** can learn TV Servicing . . . at home, in your spare time. ICS, the world's most experienced home-study school, will send you a **FREE** Demonstration Lesson (complete with sample questions) if you will merely fill out the coupon below and mail it to us.

In addition to your free demonstration lesson, we'll send you . . . also **FREE** . . . a brochure that describes the 25" (diagonally measured screen) MOTOROLA QUASAR II® Color TV chassis that we include in our TV Service Training Program.

This chassis with automatic fine tuning control is ideal for training purposes because it combines solid state devices with vacuum tubes to give you both kinds of practical experience.

Credit towards a Certified Electronic Technician (C.E.T.) rating will be granted by the National Electronics Association to ICS students upon completion of the ICS Career Program in TV Service/Repair.

# ICS

International Correspondence Schools  
Since 1890

School of Electronics  
Scranton, Pa. 18515

Approved for Veterans' Training. Eligible students use coupon address for service from ICS Canadian, Ltd. in Hawaii: 931 University Ave., Honolulu, Hawaii 96814  
Institution under the Guaranteed Student Loan Program. Accredited Member National Home Study Council. Canadian resi-

All parts carry Motorola's two year replacement guarantee!

The QUASAR II chassis comes to you in three basic sub-assemblies . . . NOT AS A KIT . . . because we want you to learn how to repair TV sets, not build them.

Our free literature also describes the fully assembled test equipment you receive such as the Deluxe 5" Solid State Oscilloscope, the tools and the learn-by-doing kits, all of the finest quality.

And we're going to tell you about eight other career opportunities in Electronics and the ICS Career Programs that can help prepare you for them. All you've got to do is mail the coupon. **SEND IT TODAY!**

ICS School of Electronics  
International Correspondence Schools  
Scranton, Pa. 18515

YES, I want you to mail to me without obligation, the FREE DEMONSTRATION LESSON and complete literature on the career program checked below. (Please check one.)

- |                                                      |                                                          |
|------------------------------------------------------|----------------------------------------------------------|
| <input type="checkbox"/> Color TV Servicing & Repair | <input type="checkbox"/> FCC Licensing                   |
| <input type="checkbox"/> Computer Maintenance        | <input type="checkbox"/> Communications/<br>Broadcasting |
| <input type="checkbox"/> CATV/MATV Technician        | <input type="checkbox"/> Hi-Fi Sound Systems             |
| <input type="checkbox"/> Telephony                   | <input type="checkbox"/> Industrial Electronics          |
| <input type="checkbox"/> Electrician                 | AC606T                                                   |

Name \_\_\_\_\_ Age \_\_\_\_\_

Address \_\_\_\_\_

City \_\_\_\_\_

State \_\_\_\_\_ Zip \_\_\_\_\_

# ELECTRONICS HOBBYIST

## CONTENTS

### PROJECTS

FALL/WINTER 1973

TRY A QUICKIE

- 46 Regulated 9-Volt Power Supply
- 62 Load Matcher
- 82 Groove Booster
- 82 Keep a Light Flashing in the Window

LOOK AND LISTEN

- 49 Magic Mike
- 91 Scramble Phone
- 101 Visulert
- 108 Diaper Snooper

SAFETY AND SECURITY

- 27 Electronic Alarm Generator
- 38 Disaster Alarm
- 103 Auto Alarm for Your Cartridge Player

TUNE RADIO ACTION

- 29 Build Mini-Maxi
- 43 VHF High-Band Converter
- 58 UHF Action Band Signal Shifter
- 77 Super Stable Aero-Band Receiver

TOOLS FOR TESTING

- 47 Instant Patch Box
- 59 A Designer's  $\pm 15V$  Power Supply
- 63 Build Cap Rapper

HOME HELPERS

- 33 Hour Master—a Super Timer
- 71 Double-Duty Skyhook Helps Flag Down that DX

SOUND INVESTMENTS

- 95 Super SCA Adaptor
- 21 Multivibrator Music Box
- 41 U-Pick-It
- 74 Vibra-tone

REPAIR AND UPGRADE

- 25 Detector X2
- 56 Put that Clock Radio Back on the Job
- 68 Getting 8-Track Players Back on the Level

PLUS MORE . . .

- 32 Antiquing an Old Tube into Antiquity
- 48 Compass Galvanometer
- 83 Super BCB Booster

### THE GOOD STUFF EVERY MAGAZINE SHOULD HAVE

- 5 Ask Hank, He Knows
- 12 New Products
- 13 Literature Library
- 15 Reader Service Page
- 20 Cartoon Page



# BUILD YOUR OWN RADIO

## and Electronics Circuits

### PROGRESSIVE HOME RADIO-T.V. COURSE

Reg. U. S. Pat. Off.



Training Electronics Technicians Since 1946

#### Now Includes

- ★ 12 RECEIVERS
- ★ 3 TRANSMITTERS
- ★ 50. WAVE GENERATOR
- ★ SIGNAL TRACER
- ★ AMPLIFIER
- ★ SIGNAL INJECTOR
- ★ CODE OSCILLATOR

- ★ No Knowledge of Radio Necessary
- ★ No Additional Parts or Tools Needed
- ★ EXCELLENT BACKGROUND FOR TV
- ★ SCHOOL INQUIRIES INVITED
- ★ Sold In 79 Countries

### YOU DON'T HAVE TO SPEND HUNDREDS OF DOLLARS FOR A RADIO COURSE

The "Edu-Kit" offers you an outstanding PRACTICAL HOME RADIO COURSE at a rock-bottom price. Our Kit is designed to train Radio & Electronics Technicians, making use of the most modern methods of home training. You will learn radio theory, construction practice and servicing. THIS IS A COMPLETE RADIO COURSE IN EVERY DETAIL.

You will learn how to build radios, using regular schematics; how to wire and solder in a professional manner; how to service radios. You will work with the standard type of punched metal chassis as well as the latest development of Printed Circuit chassis. You will learn the basic principles of radio. You will construct, study and work with RF and AF amplifiers and oscillators, detectors, rectifiers, test equipment. You will learn and practice code, using the Progressive Code Oscillator. You will learn and practice trouble-shooting, using the Progressive Signal Tracer, Progressive Signal Injector, Progressive Dynamic Radio & Electronics Tester, Square Wave Generator and the accompanying Instructional material.

You will receive training for the Novice, Technician and General Classes of F.C.C. Radio Amateur Licenses. You will build Receiver, Transmitter, Square Wave Generator, Code Oscillator, Signal Tracer and Signal Injector circuits, and learn how to operate them. You absolutely no previous knowledge of radio or science is required. The "Edu-Kit" is the product of many years of teaching and engineering experience. The "Edu-Kit" will provide you with the best education in Electronics and Radio, worth many times the low price you pay. The Signal Tracer alone is worth more than the price of the kit.

### THE KIT FOR EVERYONE

You do not need the slightest background in radio or science. Whether you are interested in Radio & Electronics because you want an interesting hobby, a well paying business or a job with a future, you will find the "Edu-Kit" a worth-while investment. Many thousands of individuals of all

ages and backgrounds have successfully used the "Edu-Kit" in more than 79 countries of the world. The "Edu-Kit" has been carefully designed, step by step, so that you cannot make a mistake. The "Edu-Kit" allows you to teach yourself at your own rate. No instructor is necessary.

### PROGRESSIVE TEACHING METHOD

The Progressive Radio "Edu-Kit" is the foremost educational radio kit in the world, and is universally accepted as the standard in the field of electronics training. The "Edu-Kit" uses the modern educational principle of "Learn by Doing." Therefore you construct, learn schematics, study theory, practice trouble shooting—all in a closely integrated program designed to provide an easily-learned, thorough and interesting background in radio. You begin by examining the various radio parts of the "Edu-Kit." You then learn the function, theory and wiring of these parts. Then you build a simple radio. With this first set you will enjoy listening to regular broadcast stations, learn theory, practice testing and trouble-shooting. Then you build a more advanced radio, learn more advanced theory and techniques. Gradually, in a progressive manner, and at your own rate, you will find yourself constructing more advanced multi-tube radio circuits, and doing work like a Professional Radio Technician.

Included in the "Edu-Kit" course are Receiver, Transmitter, Code Oscillator, Signal Tracer, Square Wave Generator and Signal Injector Circuits. These are not professional "breadboard" experiments, but genuine radio circuits, constructed by means of professional wiring and soldering on metal chassis, plus the new method of radio construction known as "Printed Circuitry." These circuits operate on your regular AC or DC house current.

### THE "EDU-KIT" IS COMPLETE

You will receive all parts and instructions necessary to build twenty different radio and electronics circuits, each guaranteed to operate. Our Kits contain tubes, tube sockets, variable, electrolytic, mica, ceramic and paper dielectric condensers, resistors, tie strips, hardware, tubing, punched metal chassis, Instruction Manuals, hookup wire, solder, selenium rectifiers, coils, volume controls and switches, etc.

In addition, you receive Printed Circuit materials, including Printed Circuit chassis, special tube sockets, hardware and instructions. You also receive a useful set of tools, a professional electric soldering iron, and a self-powered Dynamic Radio and Electronics Tester. The "Edu-Kit" also includes Code Instructions and the Progressive Code Oscillator, in addition to F.C.C. Radio Amateur License training. You will also receive lessons for servicing with the Progressive Signal Tracer and the Progressive Signal Injector, a High Fidelity Guide and a Quiz Book. You receive Membership in Radio-TV Club, Free Consultation Service, Certificate of Merit and Discount Privileges. You receive all parts, tools, instructions, etc. Everything is yours to keep.

### PRINTED CIRCUITRY

At no increase in price, the "Edu-Kit" now includes Printed Circuitry. You build a Printed Circuit Signal Injector, a unique servicing instrument that can detect many Radio and TV troubles. This revolutionary new technique of radio construction is now becoming popular in commercial radio and TV sets.

A Printed Circuit is a special insulated chassis on which has been deposited a conducting material which takes the place of wiring. The various parts are merely plugged in and soldered to terminals.

Printed Circuitry is the basis of modern Automation Electronics. A knowledge of this subject is a necessity today for anyone interested in Electronics.

### FREE EXTRAS

#### • SET OF TOOLS

- SOLDERING IRON
- ELECTRONICS TESTER
- PLIERS-CUTTERS
- VALUABLE DISCOUNT CARD
- CERTIFICATE OF MERIT
- TESTER INSTRUCTION MANUAL
- HIGH FIDELITY GUIDE • QUIZZES
- TELEVISION BOOK • RADIO TROUBLE-SHOOTING BOOK
- MEMBERSHIP IN RADIO-TV CLUB
- CONSULTATION SERVICE • FCC AMATEUR LICENSE TRAINING
- PRINTED CIRCUITRY

### SERVICING LESSONS

You will learn trouble-shooting and servicing in a progressive manner. You will practice repairs on the sets that you construct. You will learn symptoms and causes of trouble home, portable and car radios. You will learn how to use the professional Signal Tracer, the unique Signal Injector and the dynamic Radio & Electronics Tester. While you are learning in this practical way, you will be able to do many a repair job for your friends and neighbors, and charge fees which will far exceed the price of the "Edu-Kit." Our Consultation Service will help you with any technical problems you may have.

### FROM OUR MAIL BAG

J. Stantis, of 25 Poplar Pl., Waterbury, Conn., writes: "I have repaired several sets for my friends, and made money. The "Edu-Kit" paid for itself, I was ready to spend \$240 for a Course, but I found your ad and sent for your Kit."

Ben Valerio, P. O. Box 21, Magna, Utah: "The Edu-Kits are wonderful. Here I am sending you the questions and also the answers for them. I have been in Radio for the last seven years, but like to work with the Edu-Kits. I like to build Radio Testing Equipment. I enjoyed every minute I worked with the different kits; the Signal Tracer works fine. Also like to let you know that I feel proud of becoming a member of your Radio-TV Club."

Robert L. Shuff, 1534 Monroe Ave., Huntington, W. Va.: "Thought I would drop you a few lines to say that I received my Edu-Kit, and was really amazed that such a bargain can be had at such a low price. I have already started repairing radios and phonographs. My friends were really surprised to see me get into the swing of it so quickly. The Trouble-shooting Tester that comes with the Kit is really sweet and finds the trouble, if there is any to be found."

Progressive "Edu-Kits" Inc., 1189 Broadway, Dept. 513EN, Hewlett, N.Y. 11557

### UNCONDITIONAL MONEY-BACK GUARANTEE

Please rush my expanded "Edu-Kit" to me, as indicated below:

Check one box to indicate choice of model

- Deluxe Model \$31.95
- New Expanded Model \$34.95 (Same as Deluxe Model Plus Television Servicing Course and valuable Radio & TV Tube Checker).

Check one box to indicate manner of payment

- I enclose full payment. Ship "Edu-Kit" post paid.
- I enclose \$5 deposit. Ship "Edu-Kit" C.O.D. for balance plus postage.
- Send me FREE additional information describing "Edu-Kit."

Name .....  
Address .....  
City & State ..... Zip .....

**PROGRESSIVE "EDU-KIT" INC.**  
1189 Broadway, Dept. 513EN, Hewlett, N. Y. 11557

# EXPERIMENTER

International EX Crystal and EX Kits



OX OSCILLATOR  
**\$2<sup>95</sup>**

**OX OSCILLATOR** Crystal controlled transistor type. Lo Kit 3,000 to 19,999 KHz Hi Kit 20,000 to 60,000 KHz (Specify) **\$2.95**

**MX-1 TRANSISTOR RF MIXER** A single tuned circuit intended for signal conversion in the 3 to 170 MHz range. Lo kit 3-20 MHz. Hi kit 20-170 MHz. **\$3.50**

**SAX-1 TRANSISTOR RF AMP.** Amplifier to drive MX-1 mixer. Lo kit 3-20 MHz. Hi kit 20-170 MHz. **\$3.50**

**PAX-1 TRANSISTOR RF POWER AMP.** A Single tuned output amplifier to follow the OX oscillator. 3,000 to 30,000 KHz **\$3.75**



EX CRYSTAL  
**\$3<sup>95</sup>**

**EX CRYSTAL** Available from 3,000 KHz to 60,000 KHz. Supplied only in HC 6/U holder. Calib. is  $\pm .02\%$  when operated in International OX circuit or its equivalent. (Specify frequency) **\$3.95**

**BAX-1 BROADBAND AMP.** May be used as a tuned or untuned amplifier in RF and audio applications 20 Hz to 150 MHz. **\$3.75**



**CRYSTAL MFG. CO., INC.**  
10 NO. LEE • OKLA. CITY, OKLA. 73102  
Write for FREE Catalog

CIRCLE NO. 6 ON PAGE 15 OR 117

WRITE NOW FOR

## McGEE'S BIG SPEAKER CATALOG 1001 BARGAINS IN

SPEAKERS—PARTS—TUBES—HIGH FIDELITY COMPONENTS—RECORD CHANGERS—Tape Recorders—Kits—Everything in Electronics  
1901 McGee Street, Kansas City, Missouri 64108

CIRCLE NO. 8 ON PAGE 15 OR 117

## PARTS! CORNELL TUBES!

FREE Send For FREE  
CORNELL'S New Color Catalog  
48 Pgs. New Items IN LOTS OF 100  
**33¢** per tube  
**36¢** per tube  
ORDER FREE IF NOT SHIPPED IN 24 HOURS!

4219 E UNIVERSITY AVE. SAN DIEGO, CALIF. 92105

CIRCLE NO. 3 ON PAGE 15 OR 117

advertising contributed for the public good



# OF THE PEOPLE, BY THE PEOPLE, AND FOR THE PEOPLE.

The American Red Cross.

FALL/WINTER 1973 EDITION

# ELECTRONICS HOBBYIST

Dedicated to America's Electronics Hobbyists

*Editor-in-Chief*  
JULIAN S. MARTIN, WA2CQL/KMD4313

*Technical Editor*  
PETER L. DEXNIS, WA3LOQ

*Project Editor*  
STEPHEN B. GRAY

*Service Editor*  
JEFFREY APTER

*Workbench Editor*  
HANK SCOTT

*Citizens Band Editor*  
KATHI MARTIN, KAI0614

*Art Director*  
JIM MEDLER

*Cover Art Director*  
IRVING BERNSTEIN

*Associate Art Director*  
ANDY STEIGMEIER

*Advertising Director*  
DAVID J. MILLER

*Production Director*  
CARL BARTEE

*Production Manager*  
GERTRUD BORCHARDT

*Assistant Production Manager*  
MARYLYN BONILLA

*Instruments Division Manager*  
WILFRED M. BROWN

*Newsstand Circulation Director*  
DON GABREE

*Subscription and Marketing Director*  
ROBERT V. ENLOW

*President, Chairman of the Board (1957-1972)*  
B. G. DAVIS

*President and Publisher*  
JOEL DAVIS

*Vice-President and General Manager*  
LEONARD F. PINTO

*Vice-President and Treasurer*  
VICTOR C. STABILE, KBP0681



ELECTRONICS HOBBYIST is published Semi-Annually by Davis Publications, Inc. Editorial business offices: 229 Park Ave. South, New York, N.Y. 10003. Advertising offices: New York, 229 Park Avenue South, 212-OR 3-1300; Chicago, 520 N. Michigan Ave., 312-527-0330; Los Angeles: J. E. Publishers' Rep. Co. 8732 Sunset Blvd. Back issues available at New York office prepaid \$1.25 per copy. Copyright 1973 by Davis Publications Publishing Co.

ELECTRONICS HOBBYIST



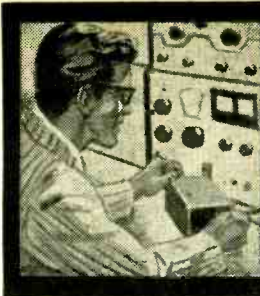

**ASK HANK,  
HE KNOWS!**

**Fast Count**

*How do I count up to eleven in the binary system of notation?*

—V.P., Utica NY

The decimal system requires that you kick off one shoe to get to eleven. However, the binary number for eleven requires only four fingers. Nope, I can't give you a quick course on binary numbers, but I will give you the decimal and binary equivalents for the first eleven numbers—see if you can figure it out.

Decimal	Binary
0	0000
1	0001
2	0010
3	0011
4	0100
5	0101
6	0110
7	0111
8	1000
9	1001
10	1010
11	1011

**It Can't Happen**

*I found the height of my antenna above sea level and the height of a Channel 2 antenna over 65 miles away. I receive the TV image fairly good and that's my problem. Our math teacher tells me the antennas are not in line with each other, the curvature of the earth puts solid ground in the way. He hasn't called me a liar, he just claims I can't measure the height of my antenna correctly. He says it is 10 feet higher than I say. What gives?*

—K.L., Monroe NY

Bend a little to the teacher, the teacher will

Hank Scott, our Workshop Editor, wants to share his project tips with you. Got a question or a problem with a project you're building—ask Hank! Please remember that Hank's column is limited to answering specific electronic project questions that you send to him. Sorry, he isn't offering a circuit design service. Write to:

**Hank Scott, Workshop Editor  
ELEMENTARY ELECTRONICS  
229 Park Avenue South  
New York NY 10003**

# exactly what you need

**LARGEST SELECTION  
ANYWHERE**

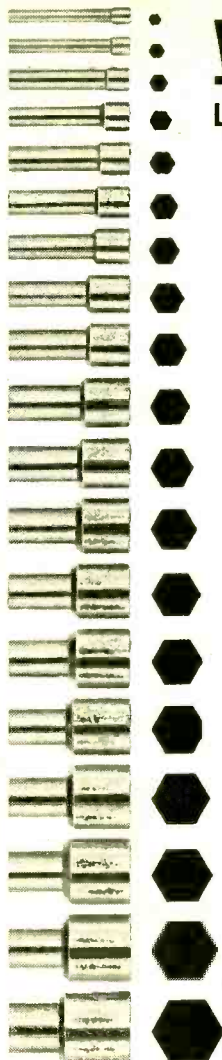

Xcelite, first with color-coded nutdrivers, offers you a size and type to drive any hex head screw or nut. Yes, metrics, too.

- hex sizes from 3/2" to 3/4" and 3 mm to 17 mm
- 3 1/2" Midgets to 21" "Super Longs"
- nickel chrome plated or plastic-dip-insulated shanks
- with clearance hole or full hollow shafts
- tough, cold drawn, accurately formed sockets, regular or magnetic
- fixed-handle or interchangeable shanks
- straight and tee handles—regular or ratcheting types
- available individually or in handy kits and sets

Made in U.S.A. to highest standards.

REQUEST FREE  
TOOL CATALOG 171



*nationwide  
availability through  
local distributors*



**professional nutdrivers**

XCELITE, INC. • 128 BANK ST., ORCHARD PARK, N. Y. 14127  
Send complete tool catalog, which includes information on all Xcelite nutdrivers.

name \_\_\_\_\_  
address \_\_\_\_\_  
city \_\_\_\_\_ state & zip \_\_\_\_\_

In Canada contact Charles W. Pointon, Ltd.

CIRCLE NO. 12 ON PAGE 150 OR 117



- THE SHOPPING CENTER FOR ELECTRONICS  
(our catalog index of Mfrs extends from ADC to XCELITE)
- HOBBYISTS . . . EXPERIMENTERS . . . SERVICE  
TECHNICIANS . . . ENGINEERS •



Your Satisfaction is Our Target  
Top Name Brands . . .  
Low Prices

AMPLE STOCKS—including  
those hard-to-find Parts  
whether you want a 15¢ capacitor,  
a \$50 FET-VOM, or a \$450 stereo  
system—you can get it at EDI!

Send for your FREE catalog Today.



**RUSH FREE CATALOG**

Name \_\_\_\_\_

Address \_\_\_\_\_

City \_\_\_\_\_

State \_\_\_\_\_

Zip Code \_\_\_\_\_

**ELECTRONIC DISTRIBUTORS INC.**

Dept. TA-2, 4900 Elston

Chicago, Ill. 60630

CIRCLE NO. 5 ON PAGE 15 OR 117

**Build  
a better  
tomorrow.**



**Take stock in America.**

With higher paying U.S. Savings Bonds.

# Ask Hank, He Knows

bend a little, and you'll both find out that TV signals do bend a slight amount. TV signals do not cast hard shadows as light does. Instead, the signal goes from very good, to fuzzy with snow, to nothing. And it takes more than 10 feet in vertical height to make a difference.

## Can't Find It

*You guys listed a Solitron integrated circuit BHA0002 for an amplifier circuit and I can't find it. What do I do?*

—H.D., Willow Grove PA

You did it, Harry, you wrote to us. Just send \$12.25 to Solitron Devices, 256 Oak Tree Rd., Tappan NY 10983 and you'll get yours.

## One For the Metric System

*What is a bayre?*

—L.M., Detroit MI

It's the c.g.s. system unit of pressure equal to one dyne per square centimeter (10.5 Newtons per square centimeter). You're not going to see much of this term in the U.S. until we swing to the Metric System whole hog. I've seen the bayre mentioned in English electronics magazines when the subject was on phono pickups.

## Look Again

*I can't find White's Radio Log. What ever happened to it?*

—T.S., Newark NJ

White's Radio Log is part of COMMUNICATIONS WORLD, a shortwave and DXer's magazine. In fact, CW is on the newsstand right now. Published by the same people that bring you this delightful mag, you can get your copy via the mail if you can't find it on the newsstand for only \$1.25. Check our mailing address on page 6.

## What's in an IC

*I know nothing about IC's and learn practically nothing from most magazines on this subject. Can you help me?*

—B. N., Conneaut OH

Two letters in the alphabet stand for a lot of electronics. For example, phase-lock-loop circuits have been known for many years, in fact a few were assembled into specially ordered receivers for the government a few years ago. However, the cost was high. An ordinary short-wave receiver would require about \$3000 worth of tube circuitry to do the job. Transistors brought the price down to about \$1000. An IC made by Signetics lowered the price to under \$5. That's what an IC is—a dollar saver. Actually, all the transistors, many of the resistors, some capacitors and internal connections for complicated circuits such as the phase-lock-loop



can be etched onto a chip with the surface area less than that of a dime. To get knowledge on the subject, I suggest you build a few circuits. Pick up a copy of 101 ELECTRONIC PROJECTS (1973 Edition) and build a few of the 30 IC projects in it. You'll learn by building.

### Look in the Scope

*I know what Lissajous figures are, Hank, but I'm not sure what I should see when the signals on the vertical and horizontal plates are of the same frequency. Is it a circle or a line slanted 45 degrees?*

—B.V.C., Miami FL

Both are correct including an ellipse whose major axis (longest dimension) is 45° from the horizontal (or vertical). Phase determines what you get. If the vertical and horizontal inputs are connected together and an AC signal supplied, a straight line will form. Shift one signal input from the other by 90° and a circle will form provided the gain controls are at equal settings. All other cases of phase shift and/or varying amplitudes form ellipses.

### Likes CB and Us

*I just finished reading the CB YEARBOOK 1973 and can't wait till 1974 for the next copy. Where can I get CB coverage every month as I got in the YEARBOOK?*

—J. K., Woodbury NJ

The staff that prepares the CB YEARBOOK works on this magazine—ELECTRONICS HOBBYIST. It's the exact same great team and I'm happy to be a part of it. In every issue we have Kathi Martin, our liberated CB editor telling it like it is. Our CB Coffee Break column is written by different people each issue, the Editor, a member of the staff or some invited guest. This way the



"It helps me while away those long, cold winter months!"

# FREE!

## LAFAYETTE 1974 CATALOG 740



Ready  
Now!

## The World's Largest Consumer Electronics Catalog

### Everything In Electronics for Home, Business, Industry

- Stereo/Hi-Fi Components • Musical Instruments and Amplifiers • CB & Ham Equipment • Tools and Test Equipment • Police and Fire Monitor Receivers • Public Address Systems • Photography Equipment • Semiconductors, Books, Parts • Plus Much More!

### Your Complete Electronics Buying Guide

Send  
Today!

Lafayette Radio Electronics  
P.O. Box 10, Dept. 47103  
Syosset, L.I., N.Y. 11791

Send FREE 1974 Catalog 47103

NAME \_\_\_\_\_

ADDRESS \_\_\_\_\_

CITY \_\_\_\_\_

STATE \_\_\_\_\_

ZIP \_\_\_\_\_

CIRCLE NO. 7 ON PAGE 15 OR 117

# TO: Electronics Hobbyist readers from the Editor of HI-FI STEREO BUYERS' GUIDE

"When you play your recordings you want the best hi-fi components you can get. HI-FI STEREO BUYERS' GUIDE tells you what they are, and whose equipment to buy. In addition to useful, authoritative articles on hi-fi componentry, every issue includes a new products Show Case, unbiased Tested in the Lab reports on quality hi-fi components, and Record and Tape Reviews on the Classics and Pops."

Let HI-FI STEREO BUYERS' GUIDE into your music life right now. Published four times a year, every issue is jammed full of information to aid you in a fuller enjoyment of your records and tapes.



Make certain you get each exciting issue by taking advantage TODAY of a special MONEY-**SAVING** introductory offer. Instead of receiving four issues; a full year subscription at the regular \$5.00 rate, you receive an extra issue, an immediate saving to you of \$1.25. Just mail the coupon below, with your payment, to HI-FI STEREO BUYERS' GUIDE, P.O. Box 2600, Greenwich, Conn. 06830.

**PAY CASH & SAVE UP TO \$2.50**

HI-FI STEREO BUYERS' GUIDE,  
P.O. Box 2600  
Greenwich, Conn. 06830

Special Introductory offer for Elementary Electronics Readers.

Okay! Enter my subscription to HI-FI STEREO BUYERS' GUIDE at the money-saving cash payment rate below:

One year (4 issues) PLUS ONE BONUS ISSUE. I enclose payment of \$5.00 and save \$1.25 off the newsstand and regular subscription rate.

DOUBLE MY SAVINGS! I prefer a two year subscription (8 issues) PLUS TWO BONUS ISSUES, a total of 10 issues. I enclose \$10.00 and save \$2.50 off the regular rates. **B406**

Enclosed is \$ \_\_\_\_\_.

Name \_\_\_\_\_ (please print)

Address \_\_\_\_\_

City \_\_\_\_\_ State \_\_\_\_\_ Zip Code \_\_\_\_\_

# Ask Hank, He Knows

column always has something to be said rather than saying something because another deadline has come around. Add to that sparkling CB editorial from time to time, and wham! Read us, you'll dig us!

## Troubles with PC Board

*How do you unsolder a component from a printed circuit board? Do I need any special tools?*

—K. H., Binghamton NY

I use the same iron to remove a part as I used to solder it in place. Sure, there are special tips, even special irons with suction attachments that slurp up solder when molten. But, the average Joe just needs some common sense and he'll do fine. First, to remove defective resistors and capacitors, cut the part in half with a hand cutter. Now, heat the point where a lead connects to the board and gently pull the part out with a long-nose plier. Pull slowly so no solder splatters. Now, remove all solder from the iron's tip and pick up excess solder from the connection until the PC board hole reappears. Sometimes you can heat the point and tap the board from behind. Be sure the hot solder splatters down to the table. Also, you can heat the spot and blow gently through the hole. Again, be careful of flying solder. Most parts with leads can be removed this way. Sockets and electrolytic cans are tougher. I rock these out of the board by heating a contact point and lifting carefully, rotating around the part until it lifts off. Remove as much solder beforehand as possible to make life easier. If you are a repairman, then I suggest you pick up some of Unger's specially designed desoldering tips.

## Indoor Car Radio Needs Power

*I would like to power a 12-volt car radio from the AC line in my den. Do you have any diagrams I could use for this purpose?*

—R. H., Estes Park CO

Sure I have, but I'm not giving them to you. The reason is simple, the parts for these circuits cost more than the Sears 28H7108 3-Ampere charger that sells for only \$7.95. It's a 12-volt rig only. If you want 6 and 12-Volt operation, then get Sears 28H7182 4-ampere charger for only \$12.95. They have other units for up to 10 amperes continuous duty for only \$34.95. Why build? You may need some filtering, but then you may not.

## Never Down

*I heard rumors that the price for an FCC Class D CB license will go down to \$15. Is that true?*

—L. K., Chicago IL

I heard the price will go up to \$25. Want to



bet? Also, Ham licenses will be \$10 each. The FCC is on a "pay-as-you-go" policy and that means you pay.

**Sky Hook Lawyer**

*My neighbor tells me that the airports will take over the licensing of all ham and CB antennas. Isn't that a bit way out?*

—L. B., Fort Worth TX

No, it is closer to the truth than you think. Actually, the day will come when all antenna masts will be limited to 20 feet, and that includes TV home antennas. If the antenna goes higher than that, the FAA must be informed and permission obtained. I guess the SST plans to fly low.

**Silly Question, Silly Answer**

*I just finished installing a burglar alarm system for the entire house. How can I be sure it is working properly?*

—H. F., Detroit MI

Turn the system on and try to break in without tripping it.

**A Question on Audio**

*I have a dual-channel stereo and I would like to know exactly what dual-channel is.*

—D.P., Detroit, MI

That's the stereo set you have, Buster, that's what dual-channel is! Seriously, hi-fi manufacturers are notorious in assigning vague, meaningless names to audio equipment. The word stereo, or stereophonic means two channels of audio. The very nature of balanced audio output for stereo sound production demands "dual-channels". But here I go sounding like a hi-fi

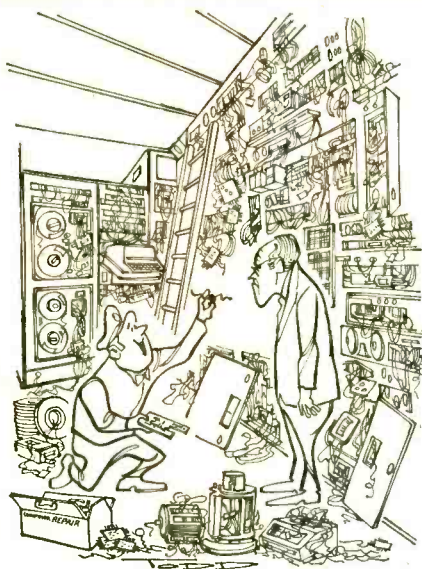

"Here's your trouble!"

**free**  
**1974 Olson®**  
**240 big page**  
**catalog**

**93 FAMOUS BRANDS!**  
**240 BIG PAGES!**  
**MANY IN FULL COLOR!**

**SAVE on the NEWEST and BEST in famous-name product lines . . .**

**A superstore of electronics at your fingertips**

- Stereo/4-Channel Sound Systems • Tape Recorders and Accessories • Radios • Phonos • Kits • Amateur and Shortwave Gear • Citizens Band • Antennas • Police/Fire VHF-UHF Radios • Electronic Calculators and Timepieces • Security • Test Equipment • 1000's of Parts, Tubes, Batteries, Wire, Hardware

**Exclusive TELEDYNE and OLSON Audio Products**

**mail this coupon today**



**Olson Electronics** Dept. CO  
 260 S. Forge St., Akron, Ohio 44327

**Send me my FREE 1974 Olson Catalog**

Name \_\_\_\_\_ Apt. \_\_\_\_\_

Street \_\_\_\_\_

City \_\_\_\_\_ State \_\_\_\_\_ Zip \_\_\_\_\_

**Send a Catalog to my friend**

Name \_\_\_\_\_ Apt. \_\_\_\_\_

Street \_\_\_\_\_

City \_\_\_\_\_ State \_\_\_\_\_ Zip \_\_\_\_\_

**CIRCLE NO. 11 ON PAGE 15 OR 117**

# Ask Hank, He Knows

manufacturer. Why don't you pick up a copy of **Hi-Fi STEREO BUYERS' GUIDE** and get the inside facts straight.

## Old for his Age

*I'm a shortwave listener and I tune the bands every night. I have a book of stations but it is in kiloHertz and I need it in megaHertz. How can I convert to megaHertz? By the way, I'm only 16, but I'm in advanced electronics.*

—S.D., Victoria TX

Just divide by 1000 to convert kiloHertz to megaHertz. That's the same as moving the decimal three places to the left. By the way, this info was covered in basic electronics.

## Needs Help

*Does anyone have a copy of the Globe Scout Model 65A manual? If you send it to me, I will make a Xerox copy and return the original to you.*

Jon Apfield WB4POT  
1679 Virginia Drive  
Eau Gallie FL 32935

Lend a hand, friends, and old Hank thanks you in advance.

## In a Rush

*I plan to fix TV sets for a living. I'd like to start collecting tubes now before I finish the course. In fact, the first lesson came today.*

—S.D., Brownsville TX

Hold on, how sure are you of completing the course. Take it easy. Put all your time and money into the learning process. In fact, why not apprentice yourself out to a TV repair shop. They have everything you need to fix a set plus the knowhow. Between books and practice, you'll soon be telling me what tubes to put into a caddy. And when you do, you'll be driving a Caddy.

## Wise Guy

*Hank, if you are so smart, what is "isochronism"?*

—L.M., Walla Walla WA

Two periodic phenomena are said to be *isochronous* when their frequencies, or periods, are equal. They need not, however, be in phase, or identical in shape. See, I'm not so dumb.

## 4-Channel

*What's the difference between SQ and QS?*

—F.B., New York NY

To the listener, practically nothing. You can't tell one system from the other except by the patent numbers. In fact, they are reasonably compatible, so much so, that SQ and QS en-



**343. MINIMOST** is an 8' outboard sports hydro you can build in just 15 hours, and at a cost of less than \$25 for materials. Its advanced underhull design makes speeds in the 30 mph range possible with a 10 hp motor. L.O.A., 8'.  
Full-size pattern set 344 \$15.00

## BUILD the REAL THING & SAVE, SAVE!



**371. JAMAICAN** is a sailing surfboard of unique construction. Fiberglass and Dynel cloth are stretched and stapled in place over a wooden framework, then resin is applied. No special building jigs or forms are needed. Foamed-in-place polyurethane adds stiffness. L.O.A., 12'; beam, 3'.  
\$5.00

Boat Builder, 229 Park Ave. S., NY, NY 10003 EH-FW3

Enclosed is \$ \_\_\_\_\_ SATISFACTION GUARANTEED.

Craft Print #343, \$5       Craft Print #371, \$5

#344 full-size pattern set \$15  
(add 50¢ for postage and handling to each print)

NAME \_\_\_\_\_ (please print)

ADDRESS \_\_\_\_\_

CITY \_\_\_\_\_ STATE \_\_\_\_\_ ZIP \_\_\_\_\_

**BUILD IT WITH CRAFT PRINTS**



coded recordings can be played on both systems and only the musical director will be able to tell the difference. As for me, I like CD-4, but that's another question.

**More on 4-Channel**

*What is CD-4 Quadraphonic Sound?*

—B.K., Syosset NY

CD-4 means Compatible-Discrete, 4-channel sound. This LP encoded technique to produce truly 4-channel discrete sound is the finest system for quadraphonic listening on the marketplace today! It is totally compatible with your present stereo records so that you can listen to full stereo on CD-4 and lose nothing. CD-4 encoded discs (at no increase in price) bring full four-channel sound to your listening area if you have the CD-4 demodulator. Also, if you only have a stereo system, buy CD-4 records. They cost no more and give perfect stereo performance playback.

**Keep Asking**

*I have a four-track tape cartridge player and I wondered if there is any way to convert it to an eight-track cartridge player. If not, is there any way I can use eight-track tapes on my tape player? If that is not possible, would you know where some good four-track tapes could be bought? Thank you very much.*

—W.T., Randolph WI

Give up the ghost on four-track and swing to eight-track by buying both the unit and tapes.

No, I doubt you can make the conversion. I'm sure, because most hobbyists who write to me do not have an iron model shop at home to do the job.



# NOW! YOU CAN HAVE YOUR OWN PROFITABLE ALARM/SECURITY BUSINESS

**Prepare at home without risk to job!**

An alarm dealer in California reported in a trade publication that he had installed 200 residential alarm systems in one year with little or no sales effort. "They just kept calling us faster than we could handle them all."

Make no mistake about it, there is great demand for new security and alarm installation businesses everywhere in the U.S.A. Yet, now you can learn everything necessary about the installation and servicing of systems, about getting customers, making estimates, running your business profitably,

right at home in state-approved training that qualifies you either for your business—or a highly-paid position in the alarm industry.

Not only can you make big money—but you can have the personal satisfaction of helping make America a better, safer place.

The course is complete in every way. There are no extras. Even the special professional tools and equipment enough to do your first job are included. Mail coupon for full information, FREE! No salesman will call.



**SECURITY SYSTEMS MANAGEMENT SCHOOL**

Division of Technical Home Study Schools  
Dept. 7480-093 Little Falls, N.J. 07424.

N.J. State Approved Diploma Awarded

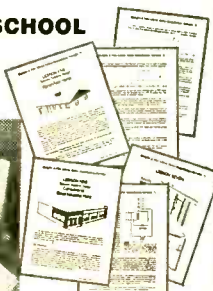

**Security Systems Management School  
Div. Technical Home Study Schools  
Little Falls, N.J. 07424, Dept. 7480-093**

**RUSH ME FREE INFORMATION ON OPPORTUNITIES IN THE ALARM AND SECURITY INDUSTRY and about your home training. No obligation! No salesman is to call.**

Name \_\_\_\_\_  
Address \_\_\_\_\_  
City \_\_\_\_\_  
State/Zip \_\_\_\_\_

CIRCLE NO. 2 ON PAGE 15 OR 117

# NEW PRODUCTS

## Telephone Amplifier

The Heathkit GD-1024 Acoustic-coupled Telephone Amplifier makes it possible to carry on a conversation without being tied to the phone—or conduct long-distance “conference” calls with the whole family taking part. The GD-1024 works with virtually any type telephone—conventional, Slim-line, Princess, etc. To use, the handset is simply placed in



the amplifier cradle. The incoming voice is then reproduced at the external speaker. Loudness can be adjusted to suit the listening area. There is no gain on the outgoing signal, as the telephone mouthpiece is sufficient to pick up your voice at any reasonable distance. Other features include all solid-state circuitry for low no-signal drain; 8-ft. speaker cord to reduce feedback, and low-cost 9-volt battery operation. Assembly time is one evening and the price is only \$14.95, mail order. For more information, circle No. 1 on a Reader Service Coupon.

## Dual Polarity Antenna

A new “super power” CB base antenna featuring a 31½-ft. boom has been announced by Avanti R & D. Called the Moonraker 6, it is a 6-element, dual polarity beam combining five sets of crossed dipole type elements plus a quad type reflector for better rejection and gain. Tunable gamma matching on both the vertical and horizontal elements handles over 2,000 watts of power, gets the lowest possible SWR, is said to provide excellent lightning protection and to be virtually trouble-free. With the antenna’s dual polarity it is possible to follow or avoid skip signals bounced off the ionosphere; when the skip

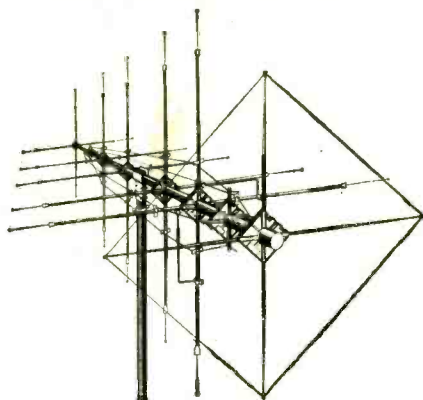

changes, polarity can be changed to eliminate the unwanted interference. DX listeners can switch back and forth and follow a conversation without the usual fade-out. Communication can be carried on with mobile units or vertically polarized base stations, then switched to horizontal if desired to contact horizontal bases. In addition to the exceptionally high power potential, Moonraker 6 specifications include 17 dB gain over isotropic, 44 dB rejection, 24 dB side rejection, and 1.2:1 VSWR. For more information, circle No. 42 on Reader Service Coupon.

## Double Jacks

Saxton Products has a patented quick-connect “Double-Jack” 2-way telephone outlet. Simply inserting the “Double-Jack” into any convenient telephone wall jack, transforms the

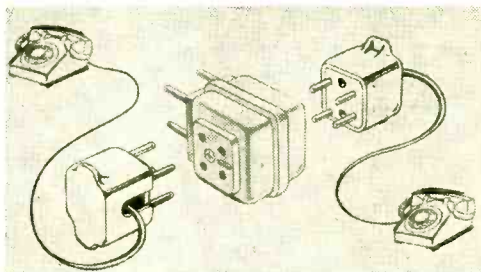

wall jack into two jacks. The “Double-Jack” permits two phones to be connected from one original jack with no reduction of power. Ideal for bedroom (his & her) extension phones. No tools are required and no wires need be connected. For further information, circle No. 44 on Reader Service Coupon.

## Micro-Mini-Microphone

This completely self-contained microphone transmitter is only 1⅞ x ½ x ⅝-inches. It will





# LITERATURE LIBRARY

101. Kit builder? Like weird products? EICO's 1973 catalog takes care of both breeds of buyers at prices you will like.

102. International Crystal has a free catalog for experimenters (crystals, PC boards, transistor RF mixers & amps, and other comm. products).

103. See brochures on Regency's 1973 lineup of CB transceivers & VHF/UHF receivers (public service/business bands—police, fire, etc.)

104. A pamphlet from *Electra* details the 6 models of the Bearcat III, a scanning monitor receiver.

105. Send for free literature of R. L. Drake's receivers—"For the ultimate in Shortwave Listening."

106. Before you build from scratch, check the *Fair Radio Sales* latest catalog for surplus gear.

107. Get *Antenna Specialists'* cat. of latest CB and VHF/UHF innovations: base & mobile antennas, test equipment (wattmeters, etc.), accessories.

108. Want a deluxe CB base station? Then get the specs on *Tram's* super CB rigs.

109. Compact is the word for *Xcelite's* 9 sets of midget screwdrivers and nut-drivers with "piggyback" handle to increase length and torque. A "show case" serves as bench stand. Cat. 171.

110. Bomar claims to have C/B crystal for every transceiver... for every channel. The catalog gives list of crystal to set interchangeability.

111. A Turner amplified mike helps get the most from a CB rig. This free brochure describes line of base & mobile station models.

112. Midland has recently published a 4-color brochure illustrating and describing over 40 CB and scanner products.

113. *EDI (Electronic Distributors)* has a catalog with an index of manufacturers' items literally from A to Z (ADC to Xcelite). Whether you want to spend 29 cents for a pilot-light socket or \$699.95 for a stereo AM/FM receiver, you'll find it here.

114. Get all the facts on *Progressive Edu-Kits Home Radio Course*. Build 20 radios and electronic circuits; parts, tools, and instructions included.

115. *Olson Electronics'* 244-page fully-illustrated 1974 catalog carries leading national brand products in all electronics categories.

116. *Trigger Electronics* has a complete catalog of equipment for those in electronics. Included are kits, parts, ham gear, CB, hi fi and recording equipment.

117. Get the *HUSTLER* brochure illustrating their complete line of CB and monitor radio antennas.

118. *Teaberry's* new 6-page folder presents their 6 models of CB transceivers (base and mobile): 1 transceiver for marine-use, and 2 scanner models (the innovative "Crime Fighter" receiver and a pocket-size scanner).

119. *Burstein-Applebee's* 1974 catalog has 276 pages of radio/TV electronics bargains. Selling for \$2, it is offered free to our readers.

120. For a colorful leaflet on the *Golden Eagle Mark III SSB receiver* and the *Mark III SSB transmitter*, write to *Browning Laboratories*.

121. *Edmund Scientific's* new catalog contains over 4000 products that embrace many sciences and fields.

122. *Cornell Electronics'* "Imperial Thrift Tag Sale" Catalog features TV and radio tubes. You can also find almost anything in electronics.

123. *Radio Shack's* 1974 catalog for

electronics enthusiasts has 180 pages, colorfully illustrated—a complete range (kits & wired) of hi-fi, CB, SWL equipment and parts.

124. It's just off the press—*Lafayette's* all-new 1973 illustrated catalog packed with CB, hi-fi components, test equipment, tools, ham rigs, and more.

125. *Mosley Electronics* reports that by popular demand the *Model A-311 3-element CB beam antenna* is being reintroduced. Send for the brochure.

126. *RCA Experimenter's Kits* for hobbyists, hams, technicians and students are the answer for successful and enjoyable projects.

127. *B&F Enterprises* has an interesting catalog you'd enjoy scanning. There are geiger counters, logic cards, kits, lenses, etc.

128. *Avanti antennas* (mobile and base for CB and VHF/UHF) are fully described and illustrated in new catalog.

129. A new free catalog is available from *McGee Radio*. It contains electronic product bargains.

130. *Semiconductor Supermart* is a new 1973 catalog listing project builders' parts, popular CB gear, and test equipment. It features semiconductor—*all from Circuit Specialists*.

131. *Heath's* new 1974 full-color catalog is a shopper's dream—chockful of gadgets and goodies everyone would want to own.

132. *E. F. Johnson's* 1974 full line of CB transceivers and accessories equipment is featured in a new 16-page brochure. A 4-color folder on monitor scanner line is also offered.

133. If you want courses in assembling your own TV kits, *National Schools* has 10 from which to choose. There is a plan for GIs.

## ELECTRONICS HOBBYIST

Box 886

Ansonia Station

New York, N.Y. 10023

Please arrange to have this literature whose numbers I have circled at right sent to me as soon as possible. I am enclosing 25¢ to cover handling. (No stamps, please).

F/W-73



- 101 102 103 104 105 106 107 108 109 110,  
111 112 113 114 115 116 117 118 119 120  
121 122 123 124 125 126 127 128 129 130  
131 132 133

Indicate total number of booklets requested  
Sorry, only 12 circled items maximum.

Are you a subscriber to this magazine? Yes  No

NAME \_\_\_\_\_

ADDRESS \_\_\_\_\_

CITY \_\_\_\_\_

STATE \_\_\_\_\_ ZIP \_\_\_\_\_

Not Valid After March 15, 1974

# NEW PRODUCTS

pick up the slightest sound and transmit it without wires, up to 450 feet through any FM radio. Tunable from 88 to 108 MHz, the Micro Mini Mike is ideal for use as a silent monitor, burglar alarm, music amplifier, intercom, baby sitter, etc. The unit furnished complete with batteries on a money back guarantee. Only \$13.95 plus 50c for postage and handling. Additional information is available from AMC Sales, P.O. Box 2923, Pasadena, CA 91105.

## Drill Anywhere

A new 1/4-in. cordless electric drill that gives power where there is no power has been introduced at \$49.99 by The Black & Decker Co. The new cordless unit, Model 7077, is priced 33% below the previous Black & Decker

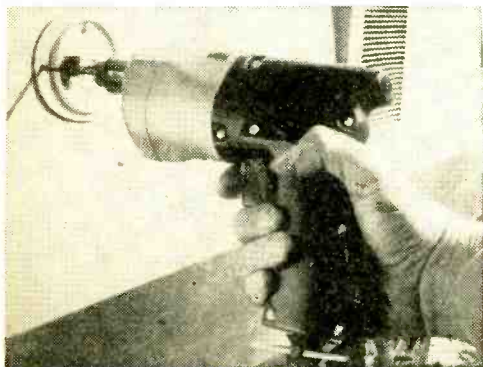

er cordless drill model. The 7077 is the result of productivity improvement programs and technological advancements. The #7077 is driven by a self-contained power pack. A charger unit that fully recharges in 16 hours is included as standard equipment. The new cordless tool drills at 800 revolutions per minute and weighs under 3 1/2 pounds. Circle No. 46 on Reader Service Coupon for more facts.

## Cool Solder

Ever wish you could solder a connection with a match? Now you can with Archer Tape Solder, from Radio Shack. Simply twist your wires together, wrap them with a piece of Tape Solder, and melt it with a match, candle

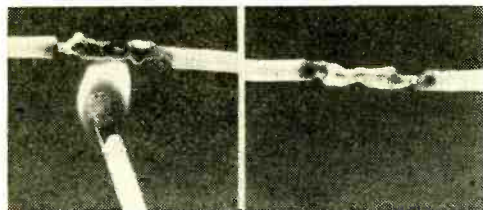

or cigarette lighter flame. No soldering iron needed! According to Radio Shack, Tape Solder is ideal for on-the-spot wiring and repairs, installing light fixtures, automotive accessories, while camping or practically anywhere. Archer Tape Solder comes in a re-sealable plastic pouch of 100 pre-cut pieces for 89¢. Available from more than 1800 Radio Shack and Allied Radio Stores in all 50 states and Canada, and through Radio Shack Authorized Sales Centers, nationwide. For more information, circle No. 48 on a Reader Service Coupon.

## Every Bench Should Have One

Recurrent sweep with automatic synchronization and a phasing control are included in the new LBO-511, wideband solid state general purpose oscilloscope/vectorscope now offered by Leader Instruments Corp., Long Island City, NY. Sweep frequency of the Model LBO-511 is in four ranges, from 10Hz to 100KHz while the phasing control is continuous from 0 to 140°. In addition, the unit has a calibrated vertical input and with 20MVp-p/cm to 10Vp-p/cm sensitivity. FET input stages plus DC coupling and push/pull amplifiers are said to account for unvarying stability and distortion-free displays of this

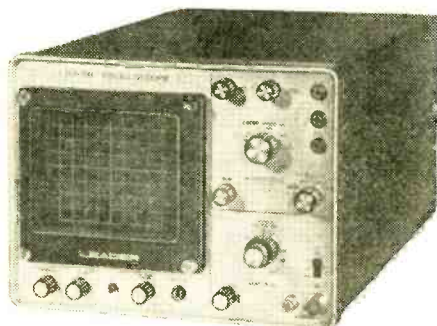

new entry. Special inputs are also included to allow use as a vectorscope. Bandwidth is at DC to 10MHz. Power requirements are 115/230V; 50/60Hz; 25VA (approx.). The LBO-511 weighs 15 lbs. and measures 7 3/8-in. H x 9 7/8-in. W x 16 1/2-in. D. Price is \$349.95. Want more facts—circle No. 32 on Reader Service Coupon.

## Stereo on the Go

The Lafayette "Auto Mate" is equipped with powerful solid-state circuitry to provide quality stereo sound playback of prerecorded cassette tapes. It is so compact it can be installed in the glove compartment of most cars. Measures only 6-in. W x 1 7/8-in. H x



# ELECTRONICS HOBBYIST

## READER SERVICE PAGE

• The Editor of **ELECTRONICS HOBBYIST** offers readers an easy way to get additional information about products and services advertised in this issue. Also, if you would like more information about any new product mentioned in our new products column, it's yours for the asking. Just follow the instructions below and the material you requested will be sent to you promptly and at no cost.

• The coupon below is designed for your convenience. Just circle the numbers that appear next to the advertisement or editorial mention that interests you. Then, carefully print your name and address on the coupon. Cut out the coupon and mail to **ELECTRONICS HOBBYIST**, Box 886, Ansonia Station, New York, N.Y. 10023. Do it today!

Void after March 15, 1974

F/W 1973

### ELECTRONICS HOBBYIST

Box 886, Ansonia Station, New York, N.Y. 10023

Please arrange to have literature whose numbers I have circled at right sent to me as soon as possible. I understand that this is a free service offered by the magazine.

1	2	3	4	5	6	7	8	9	10
11	12	13	14	15	16	17	18	19	20
21	22	23	24	25	26	27	28	29	30
31	32	33	34	35	36	37	38	39	40
41	42	43	44	45	46	47	48	49	50
51	52	53	54	55	56	57	58	59	60

Name (Print Clearly) \_\_\_\_\_

Address \_\_\_\_\_

City \_\_\_\_\_

State \_\_\_\_\_

Zip Code \_\_\_\_\_

# NEW PRODUCTS

6½-in. D. Placing a cassette into the front panel slot will start playback automatically and light goes on. Features separate tone and volume controls, plus slide lever balance



control for adjusting proper sound level in each speaker. Includes fast forward and eject buttons. Operates on 12-volt negative ground systems. Speaker impedance 4-8 ohms. Mounting brackets included for only \$39.95. Two 3-in. x 5-in. matching speaker systems are also available at Lafayette at extra cost. For more information, circle No. 34 on Reader Service Coupon.

## Snaps are a Cinch

Time Saver Tool Corporation has announced the expansion of its line of vise plier attachments. In addition to attachments for setting snap fasteners and grommets the new Handyman's Clinch-Fast Kit will include attachments for setting rivets, rivet removing,

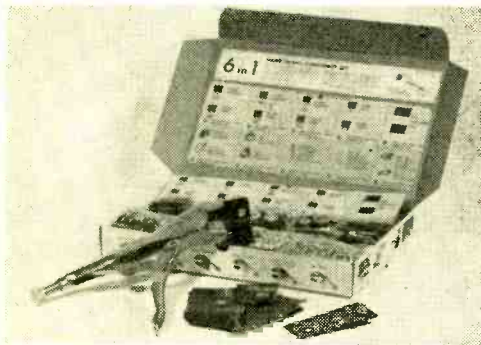

center punching, counter sinking, and Lexan slip-ons for clamping painted, plated or fragile materials. The kit also includes an assortment of snap fasteners, grommets, rivets, and one Vise Grip (No. 10R) by Petersen. Ideal for on-the-job work and for making tarps, boat and trailer covers, the kit can also be used for leather work, sheet metal fastening, and other household and shop repairs. For more info, circle No. 36 on Reader Service Coupon.

## Ultrasonic Intrusion Sensor

"The Informer", prepared by Heath Company, may not make the bestseller list, but will be a valuable addition to any bookcase because this book keeps a vigilant watch on home and belongings. Between the bogus covers of "The Informer" is the Heathkit GD-39, a sophisticated solid-state ultrasonic sensor that can be used to trigger an alarm, turn on a light, or both should it detect movement in the area under surveillance. To install, the homeowner simply plugs it into a 120 VAC wall outlet, then plugs the alarm and light into the receptacles provided. "The

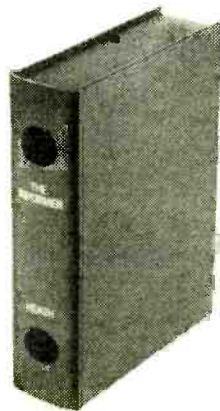

Informer" has adjustable sensitivity, automatic and manual reset, and a built-in 30 second delay circuit so the owner can enter a room and deactivate the alarm. The kit-form device can be built by a beginner in approximately two evenings, and can be positioned to survey an entire room or an entranceway. Mail order price for the Heathkit GD-39 Informer is \$49.95 FOB. For further information, circle No. 1 on Reader Service Coupon.

## CB Eyeball Messages

A set of four flags designed to alert passing motorists to a specific need of distressed au-  
*(Continued on page 111)*





# Check these Heathkit Plus-Values in electronic equipment... for every interest, every budget.

Your dollars buy more in Heathkit electronics, hand-crafted by you. More quality. More features. Better performance. Added self-service savings. Plus the personal pride and satisfaction you get from creating something of value with your own hands. It all adds up to the "plus-value" inherent in every Heathkit product. Check the new Heathkit products shown at right. They're just a few of the world's largest selection of electronic kits described in the new FREE Heathkit catalog.

NEW Heathkit Acoustic Coupled Telephone Amp. \$14.95\*



Heathkit 50-watt Stereo Receiver. \$169.95\*



NEW Heathkit Ultrasonic Intrusion Alarm. \$49.95\*



Heathkit Deluxe Metal Locator. \$89.95\*



NEW Heathkit 2-Meter Amateur Transceiver. \$179.95\*



Heathkit VHF/FM Band-Scanning 8 channel Receiver. \$119.95\*



Heathkit 6-Digit Electronic Clock-Alarm. \$34.95\*

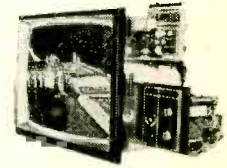

Heathkit 25V Solid-state Color TV with detent power tuning. \$599.95\*



NEW Heathkit 8-digit desktop Calculator. \$79.95\*

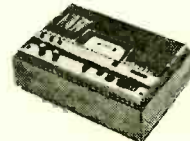

Heathkit Cassette Deck, with Dolby Circuit. \$249.95\*



NEW Heathkit 8-transistor AM Radio for first-time kit-builders. \$14.95\*



Heathkit 2 1/2 Digit VOM. \$79.95\*



NEW Heathkit 8-digit pocket Calculator. \$32.50\*

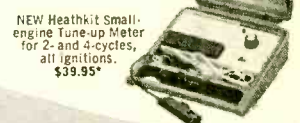

NEW Heathkit Small-engine Tune-up Meter for 2- and 4-cycles, all ignitions. \$39.95\*

See them all at your nearest Heathkit Electronic Center...or fill out the coupon below.

**HEATHKIT ELECTRONIC CENTERS** — ARIZ.: Phoenix; CALIF.: Anaheim, El Cerrito, Los Angeles, Pomona, Redwood City, San Diego (La Mesa), Woodland Hills; COLO.: Denver; CONN.: Hartford (Avon); FLA.: Miami (Hialeah); GA.: Atlanta; ILL.: Chicago, Downers Grove; IND.: Indianapolis; KANSAS: Kansas City (Mission); MD.: Baltimore, Rockville; MASS.: Boston (Wellesley); MICH.: Detroit; MINN.: Minneapolis (Hopkins); MO.: St. Louis; N.J.: Fair Lawn; N.Y.: Buffalo (Amherst), New York City, Jericho; L.I. Rochester; OHIO: Cincinnati (Woodlawn), Cleveland; PA.: Philadelphia, Pittsburgh; R.I.: Providence (Warwick); TEXAS: Dallas, Houston; WASH.: Seattle; WIS.: Milwaukee.

HEATH  
Schlumberger

HEATH COMPANY, Dept. 26-9  
Benton Harbor, Michigan 49022

Please send FREE Heathkit Catalog.

Name \_\_\_\_\_

Address \_\_\_\_\_

City \_\_\_\_\_ State \_\_\_\_\_ Zip \_\_\_\_\_

\*Mail order prices; F.O.B. factory. CL-475R

CIRCLE NO. 1 ON PAGE 15 OR 117

# PRINTED CIRCUITS

by Jack Schmidt

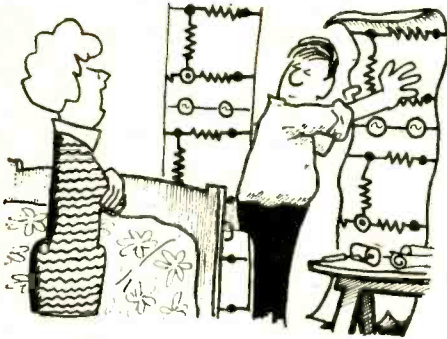

"Not on my bedroom wall!"

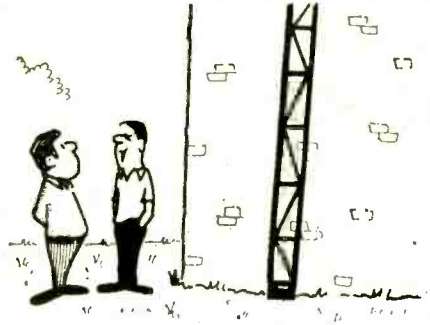

"It's painted right on the building!"

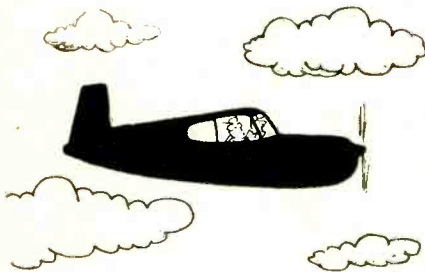

"No wonder we're lost—you've been following a schematic!"



"There's your trouble . . . three supply circuits shorted by . . ."



"How can you trace those squiggly lines on boards, Harry, then get lost going to St. Louis?"

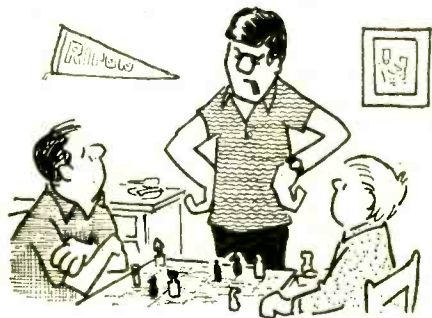

"Chess board my foot—it's the chassis boards from my home study course!"



**I replaced one Organ  
Grinder and  
a tin cup  
with my...**

**ELECTRONICS  
HOBBYIST**

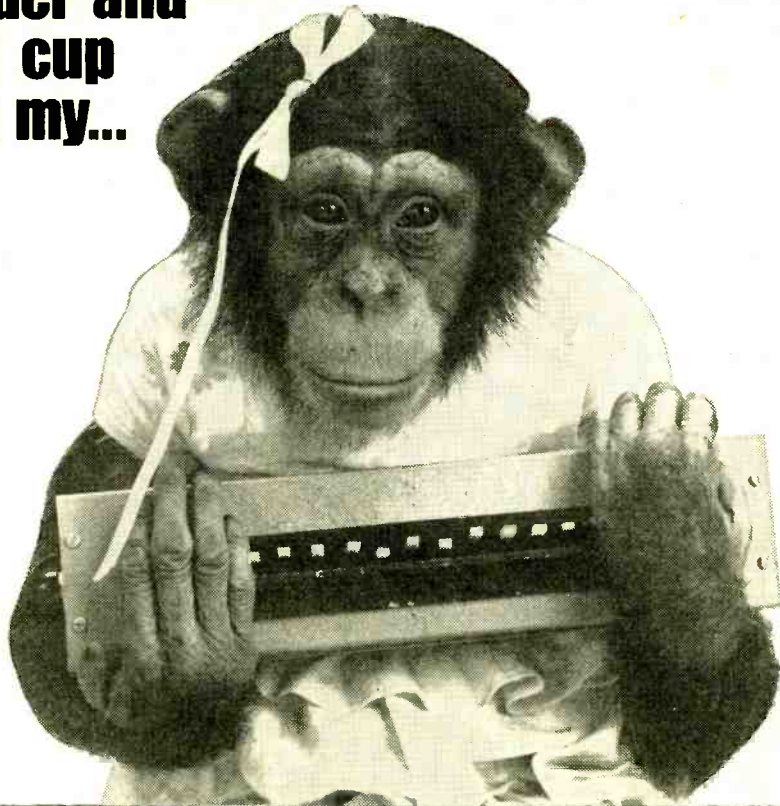

## **MULTIVIBRATOR MUSIC BOX**

**by James Robert Squires**

**E**ver see a grown man stop at the counter of a toy shop and pound out the notes of some half forgotten song on a toy piano? It happens to all of us and usually results in a special kind of music definitely not Lincoln Center but of our own making. Children share this special pleasure in music and often their uninhibited efforts at the keyboard result in something worth listening to.

To all but the sophisticated ear, tones generated by a square wave source can sound similar to those produced by a sine wave oscillator. The multivibrator music box uses 12 notes; unusual chords result from combinations of these notes. The box is portable, has an earphone jack, and can be played through your radio so that you can accompany your favorite music. Two speakers connected in parallel give plenty of volume when you want it.

**From Resistors To Notes.** Four transistorized multivibrators are used, each is capable of running at one of three frequencies by chang-

# Music Box

ing the base resistors. Depressing one of the 12 keys connects battery voltage to a different base resistor.

Outputs of the four multivibrators are summed in 680-ohm resistors and thereafter fed to an amplifier. The amplifier output, the summed result of four multivibrators, is then used to drive the output speakers—assuming that the output jack has not had either a headset or a radio-phono input plugged in.

Each multivibrator is identical in design to the others except for the frequency forming circuits in one leg of each. The frequencies go higher, piano fashion, from left to right. It establishes a sort of face value between piano and organ. However, here the similarity stops. Shying away from expensive precision values to establish exact note jumps (intervals), I used standard *RETMA* value resistors. The table indicates the switch, its approximate frequency, and also its relation to keys on a piano. The range of the music box is roughly that of a piccolo. Frequencies will, therefore, deviate from pure Steinway, so that those fortunate with perfect pitch may be somewhat pained by the box's output. (For perfectionists you might add a series of adjustable potentiometers and reduce the present "base" resistors by about 20 percent of their value. Select a series potentiometer with a resistance value about half the value of its associated base ( $R_a$  to  $R_{11}$ ) resistor.) Then, each frequency is tunable within limits.

**Building Hints.** The entire circuit was mounted on a Vectorboard. The transistor sockets and interconnector wires are installed first, leaving actual components until last. Locate parts as shown unless you can find a better way. Location is not that critical. When the circuit board is completed, mount the chassis components.

Speakers, volume control, power switch and output jack are mounted at one end, preferably near the output transistor. The entire music box is housed in a 13 x 3 x 2 $\frac{5}{8}$ -in. enclosure and can be painted to suit your own musical-color mix. Keys are any style of lever microswitch. Often these switches can be picked up at the local electronics store in the bargain section for a fraction of the manufactured cost. Spacers are used between each switch for rigidity. I used cop-

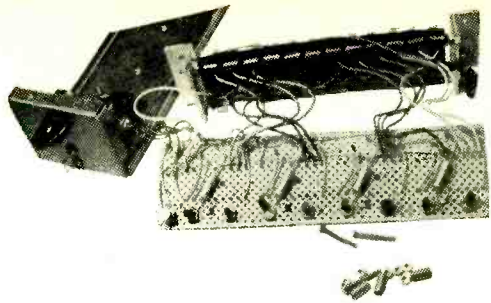

**Underside of vectorboard shows no monkey-business! Just a keyboard tiepoint, Q1 to Q9 transistors and capacitors C2 thru C5.**

per tubing to cut spacers because it was easy. You may purchase precut spacers or make your own as the mood suits you. The switch assembly is separate and is mounted on the opposite wall from the speaker deck with a rectangular opening cut in the box to project the lever switch arms through. This method of mounting the switches places them at about the right spacing for fingers,

## PARTS LIST FOR MULTIVIBRATOR MUSIC BOX

- Battery—Six AA cells in series
- Ca—0.1  $\mu$ F Mylar capacitor, 12 VDC or better
- Cb—0.082  $\mu$ F Mylar capacitor, 12 VDC or better
- Cc—0.047  $\mu$ F Mylar capacitor, 12 VDC or better
- Cd—0.033  $\mu$ F Mylar capacitor, 12 VDC or better
- C1, C6, C7, C8—0.015  $\mu$ F Mylar capacitor, 12 VDC or better
- C2 to C5—5  $\mu$ F non-polarized electrolytic or tantalum capacitor, 15-50 VDC
- J1—Jack with normally closed switch, any style
- Q1 to Q8—2N3703, HEP-57, RS 276-2024, etc.
- Q9—2N428, HEP-2, RS 276-2004, etc.
- Ra—120,000-ohm,  $\frac{1}{4}$ -watt resistor
- Rb—100,000-ohm,  $\frac{1}{4}$ -watt resistor
- Rc—82,000-ohm,  $\frac{1}{4}$ -watt resistor
- Rd—68,000-ohm,  $\frac{1}{4}$ -watt resistor
- Re—56,000-ohm,  $\frac{1}{4}$ -watt resistor
- Rf—47,000-ohm,  $\frac{1}{4}$ -watt resistor
- Rg—39,000-ohm,  $\frac{1}{4}$ -watt resistor
- Rh—33,000-ohm,  $\frac{1}{4}$ -watt resistor
- Ri—27,000-ohm,  $\frac{1}{4}$ -watt resistor
- Rj—22,000-ohm,  $\frac{1}{4}$ -watt resistor
- Rk—18,000-ohm,  $\frac{1}{4}$ -watt resistor
- Rl—15,000-ohm,  $\frac{1}{4}$ -watt resistor
- R1, R3, R10, R12, R13, R15, R16, R18—1000-ohm,  $\frac{1}{4}$ -watt resistor
- R2, R11, R14, R17—3300-ohm,  $\frac{1}{4}$ -watt resistor
- R4 to R7—820-ohm,  $\frac{1}{4}$ -watt resistor
- R8—8200-ohm,  $\frac{1}{4}$ -watt resistor
- R9—1000-ohm, audio taper potentiometer
- S1 to S12—SPST microswitch, lever type (see text)
- S13—SPST toggle or slide switch (ON—OFF)
- T1—Miniature output transformer, 500 ohms to 8 ohms (Lafayette 33-85572 or equiv.)



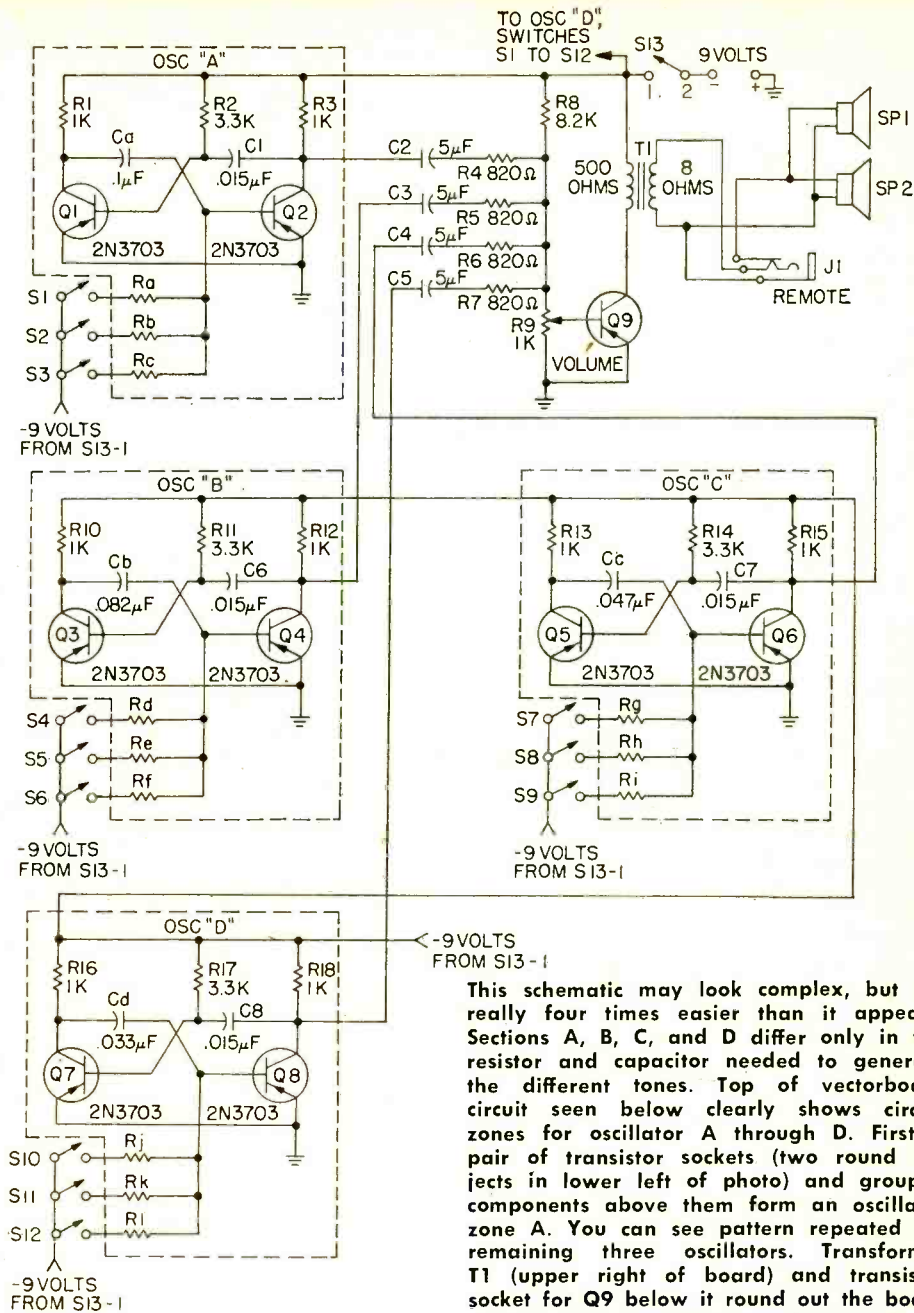

This schematic may look complex, but it's really four times easier than it appears! Sections A, B, C, and D differ only in the resistor and capacitor needed to generate the different tones. Top of vectorboard circuit seen below clearly shows circuit zones for oscillator A through D. First a pair of transistor sockets (two round objects in lower left of photo) and grouped components above them form an oscillator zone A. You can see pattern repeated for remaining three oscillators. Transformer T1 (upper right of board) and transistor socket for Q9 below it round out the board with an audio amplifier output power stage.



# Music Box

both chubby and inept.

Be careful to connect all wiring to the lower edge of the circuit board. This will allow the board to swing out and away for underside servicing and test. Mounting screws or nuts should stand clear of any component.

The battery pack is wired to the power switch S1, then onto the circuit board. It's a good idea to check your wiring prior to installing any transistors. You can do this by measuring the voltage between the collector of any transistor and its emitter. You should have 9 volts with all transistors out and no key depressed.

The keys are assembled to a subchassis which is then mounted to the main chassis behind a curtain of black felt. Mount a piece of angle aluminum below the keys if you wish to limit the travel or downward motion of the keys.

**Operation.** Just as each of the 12 separate

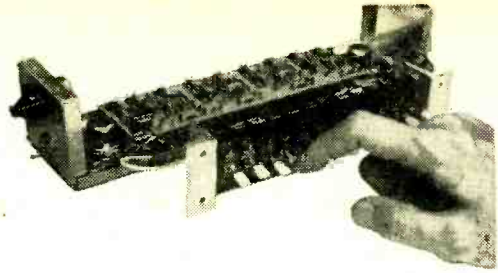

Use any SPST spring return switch you have available. Often surplus units can be used that can be purchased quite inexpensively.

keys produces an individual note, so will combinations of keys produce chord notes. I have tried to use standard resistor values. The result is that the frequency difference between notes does not match piano notes. Instead, a new kind of music called *stock value* music is generated. This music deviates from the old tonal scale and adheres to a new scale named for the resistors used to generate the music. They can, of course, be purchased from any electronics parts house as opposed to expensive precision valued resistors that would be necessary to produce the old classical scale values all those other musicians insist on using. Don't be disappointed though 'cause you're in for a treat. Stock value music has much to offer for the growing number of fans interested in electronic music. Battery life? Well, it's not as long as Tchaikovsky's Swan Lake nor as short as the theme from Exodus. I guess you can say that battery life will depend upon the number of concert recitals per week. Batteries have a way of recovering after a strenuous performance—as I am sure your friends will! And now I leave you to your moments of construction fun and hours of *stock valued* musical ecstasy. ■

## FREQUENCY CHART

Key Switch Number	Approximate Frequency (Hertz)	Approximate Musical Note	Resistor Value (10%)
S1	625	E	120K
S2	716	F	100K
S3	845	A	82K
S4	1030	C	68K
S5	1220	E	56K
S6	1561	G	47K
S7	1750	A	39K
S8	2080	C	33K
S9	2500	E	27K
S10	3030	G	22K
S11	3450	A	18K
S12	4150	C	15K

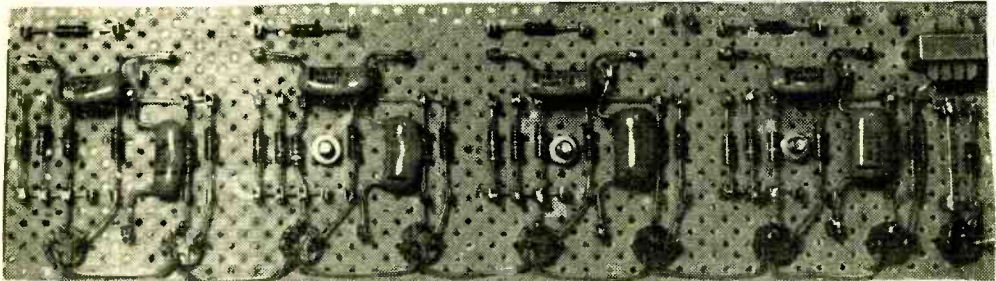

This project is based on the use of standard resistors. The ½-watt 10 percent tolerance type is usually the least expensive, but you can use any closer tolerance or ¼-watters. Exact pitch requires pots; see text.





# Improve any AM receiver with... **DETECTOR X2**

One diode and capacitor added to any AM detector will nearly double the output.

by Elmer C. Carlson

**I**F YOU CAN SOLDER to printed-circuit boards or build a solid-state electronics kit, you can convert any AM detector to an even better voltage doubler circuit. All you have to do is add two small components to the existing diode detector, and you can get about double the normal audio output. Another big bonus is a lower detector distortion and an intrinsic bass boost that's noticeable mainly on medium-priced table radios. Remember, the new circuit isn't choosy. You can put it in CB mobiles or hand-talkies, table radios or broadcast/shortwave transistor portables. You can even put this circuit in toy-type crystal sets.

Circuitry used for this high-output AM detector is the same as that used as a power rectifier for those transformerless TV power supplies. For over twenty years the circuit has been used to obtain about 240 VDC from 120 VAC power lines. The only difference are the characteristics of the components used. As an AM detector-doubler, the circuit uses high-frequency, low-current diodes instead of 500 or 750 milliamper power rectifiers. Capacitors are small at the higher (RF and IF) frequencies. A .01  $\mu\text{F}$  capacitor is usually enough. Those 80 to 200  $\mu\text{F}$  electrolytic capacitors aren't needed

for the AM detector-doubler circuit.

**Circuit Operation.** Basic circuits for the usual half-wave AM detector, the AM detector-doubler and the crystal radio circuits are given in the schematic diagrams. During

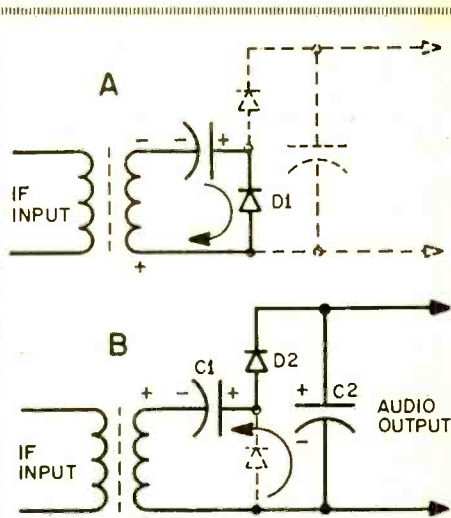

At A, C1 charges as shown for  $\frac{1}{2}$  of each IF cycle then aids (B) second  $\frac{1}{2}$  cycle, charging C2 to twice the IF.

# DETECTOR X2

one alternation of the IF carrier, diode D1 of the X2 DETECTOR *conducts*. When diode D1 conducts, it charges capacitor C1 to the peak IF voltage of that half of the cycle of the modulated sine wave. During the second half of the cycle, diode D2 conducts. Capacitor C1 discharges through diode D2, adding its briefly stored charge to that of the peak voltage of the second half of the input sine wave. At the time of discharge, the voltage across C1 is in series with the voltage applied to the secondary of the transformer during the second half of the sinewave alternation. Just as with two dry cells connected in series, these two voltages add and produce about twice the voltage that would be obtained with one diode.

**Modification Tips.** A pair of identical diodes will work best in this circuit. Any two diodes will work, but identical diodes will give better audio fidelity. Check the forward and back resistance of diodes with an ohmmeter. Select two diodes that are as similar as possible.

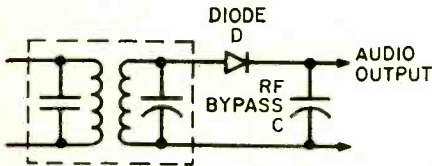

This basic AM detector is found in nearly all AM radios. Diode can be connected as shown or reversed with anode at out line.

When removing a diode from the original circuit be sure to check its operating output polarity. Make sure diodes you put into the circuit will give the same polarity audio voltage output. A diode connected

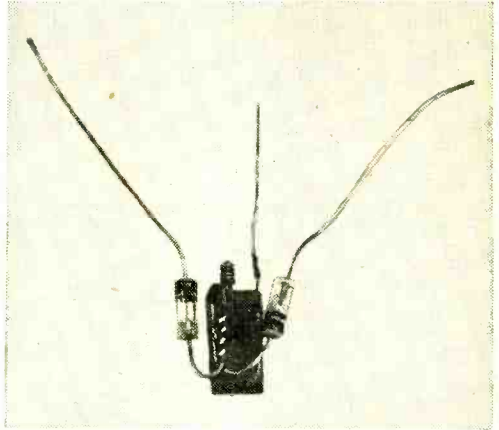

Simple three-terminal design using two new diodes and additional capacitor. Selecting a matched set of diodes drops distortion.

to the circuit in reverse may upset the bias applied to the base of a following, direct-coupled transistor or electrolytic capacitor. It's a lot easier to check the polarity first than to replace a transistor or electrolytic capacitor.

If space permits, larger-sized diodes and capacitors can be used just as effectively as the miniaturized units.

The two diodes and the capacitor can be formed into a neat, compact 3 terminal package as shown in the photo-  
(Continued on page 116)

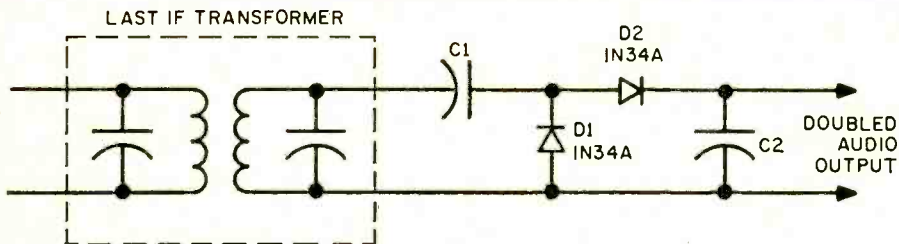

Add just a diode and capacitor to the basic circuit shown above and turn an ordinary AM detector into a doubler. It boosts audio quality by reducing distortion since the load seen by the last IF transformer is equal for both half-cycles of the IF output waveform.

## PARTS LIST FOR DETECTOR X2

C1—Capacitor, ceramic or mica. Size depends on C2, see text.  
C2—Capacitor in original detector circuit.

D1—Diode, 1N34A or 1N60  
D2—Diode in original detector circuit, see text



# SOUND OFF WITH THIS NOISEMAKER

## ELECTRONIC ALARM GENERATOR

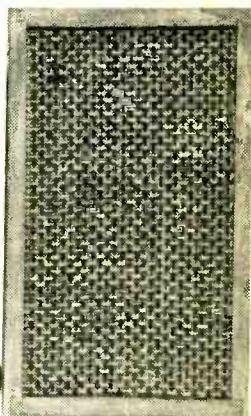
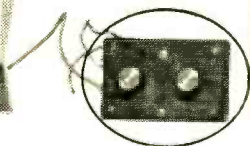
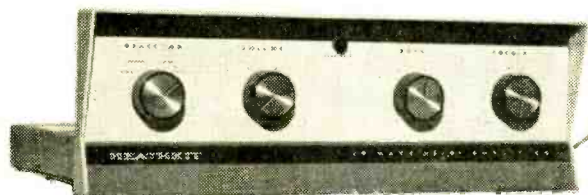

by Gary McClellan

There are times to make noise in these days of noise abatement concern. Of course, an ambulance must have a wailing siren to help clear traffic. A volunteer fire department depends on a raucous blast from a horn for its efficient operation. And certainly no one would deny a new-year's eve merrymaker his hour to howl. So whatever your interest—burglar alarm to wake-up alarm—here's an electronic alarm generator with an extra low-frequency modulation oscillator that produces a "yelp-yelp-yelp" that's sure to attract plenty of attention.

Both the pitch and repetition rate of this generator are variable over a wide range, so you can create other unusual sounds. If you want to experiment with the circuit, you will probably discover other hookups that give even more strange sounds.

**What Is It?** It's an electronic alarm generator that's inexpensive and easy to build. The parts are all common and inexpensive. There are no oddball integrated circuits to buy, and you will probably have most of the parts in your junkbox. If not, you shouldn't have to spend more than \$4 for new parts. Construction? It's very easy! The parts layout is noncritical and you can build it in any way, shape, or form you wish. Our generator uses two unijunction transistor oscillators which are DC coupled to produce the strange sounds.

Electronically, the first oscillator (which consists of C1, Q1, R1, R2 and R3) gener-

ates a series of low frequency pulses. The output of this oscillator appears across R3 as a corresponding series of voltage fluctuations. R3 also biases the second oscillator (consisting of C3, C4, Q2, R4, R5 and R6) to a point just below oscillation. This resistor must be adjusted to suit the characteristics of the unijunction used for Q2. As the voltage across R3 drops, it will reach a level where the second oscillator fires and its output frequency starts to rise with the voltage. As the voltage across R3 increases, the output frequency drops. Potentiometer R1 controls the repetition rate of the output, while pot R5 controls the frequency.

**Putting It Together.** I built my version on

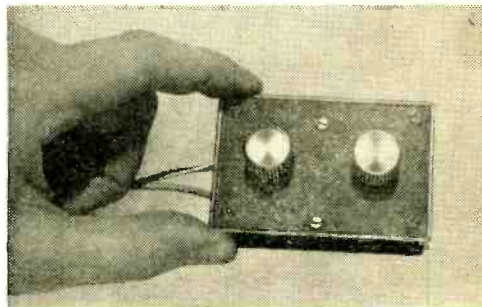

Great for attention-getting emergency type alarms. So easy to build, it's recommended for beginners. Inside the case just a dozen parts put a warbling squawk of a sound into your hi-fi, PA amp—even drives earphones!

# ALARM GENERATOR

a 1 $\frac{7}{8}$ -in. x 2 $\frac{1}{4}$ -in. scrap of perfboard and enclosed it in a Radio Shack Mini Case. This arrangement worked very well and you might want to duplicate it.

Start construction by laying out the capacitors on the perfboard. Note that C1 and C4 are positioned near the ends of the board. Next, insert all of the resistors but R3. The value of R3 will probably have to be optimized by experiment, so just ignore it for now. On our version potentiometers R1 and R5 were left off the board to save space. These pots are mounted on the front panel of the box and connected to the circuit via short leads. You should now be able to wire up most of the circuit, and you might want to add push-in terminals for the pots, output, and power leads. These terminals will make external connections to the board much easier.

When you have finished the wiring, insert the unijunctions. Be careful to check out the leads on your particular unijunctions before you solder them in. The location of the E, B1, and B2 leads may vary with the type of unijunction you use.

Finish the construction by "working" the

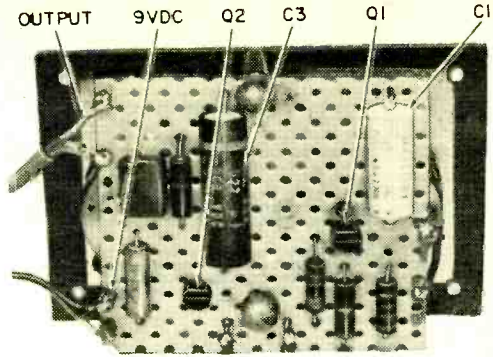

Locate parts on this photograph as you put parts together. Also, see page 115 for the complete wire layout under the perf-board. Drill two  $\frac{1}{4}$ -in. holes in one side of the box for the power and output leads. Next, the front panel: drill two holes for the pots and two holes to mount the board. Clean up the panel and apply decals if you wish. Install the two pots and temporarily wire them to the rest of the circuit with long leads. Also connect the power and output leads to the module. This completes your mechanical construction of the generator.

**Putting It To Work.** By now you should be all set to fire it up. In place of R3 connect a series combination of 330-ohm (Continued on page 115)

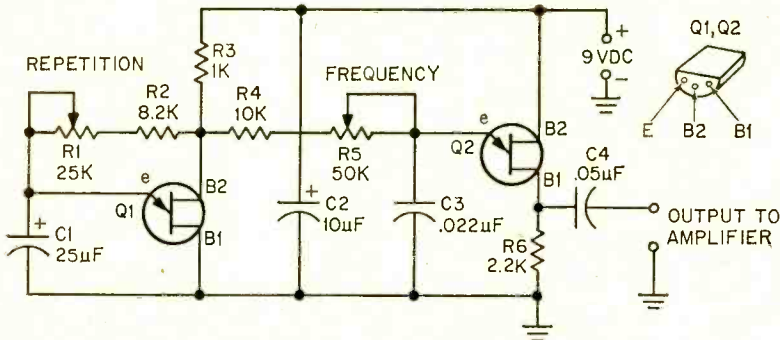

## PARTS LIST FOR ELECTRONIC ALARM GENERATOR

C1—25  $\mu$ F electrolytic capacitor, 12 VDC or better (Allied Radio 926-1547 or equiv.)  
 C2—10  $\mu$ F electrolytic capacitor, 12 VDC or better (Radio Shack 272-1002 or equiv.)  
 C3—0.022  $\mu$ F tabular capacitor, 50 VDC or better (Radio Shack 272-1056 or equiv.)  
 C4—0.05  $\mu$ F capacitor, 12 VDC or better (Radio Shack 272-1068 or equiv.)  
 Q1, Q2—Unijunction transistors, exact type not critical (Radio Shack 276-111)  
 R1—25,000-ohm potentiometer, linear taper (Radio Shack 271-094 or equiv.)  
 R2—8,200-ohm,  $\frac{1}{2}$ -watt resistor (Radio Shack

271-000 or equiv.)  
 R3—1000-ohm,  $\frac{1}{2}$ -watt resistor, see text (Radio Shack 271-000 or equiv.)  
 R4—10,000-ohm,  $\frac{1}{2}$ -watt resistor (Radio Shack 271-000 or equiv.)  
 R5—50,000-ohm potentiometer, linear taper (Radio Shack 271-1716 or equiv.)  
 R6—2,200-ohm,  $\frac{1}{2}$ -watt resistor (Radio Shack 271-000 or equiv.)

Misc.—Perfboard, knobs, spacers, wire, solder, case (Radio Shack 270-230), 9-volt battery or power supply, etc.



**O**UR MINI MAXI is a novel superregenerative receiver, covering the 80 to 175 MHz band. Though designed with minimum circuitry, it provides good sensitivity and output. This simple and easy-to-build receiver is unique in that no coupling capacitors or transformers are used between stages and almost any impedance speaker or earphone can be connected to the output. Of course, a low-impedance one will have higher output. Another feature is the use of non-critical components which can vary in value to permit using a wide range of readily available parts without impairing performance of the receiver. The Mini-Maxi will receive television, FM, aircraft, amateur, and police transmissions with just a 2-ft. whip antenna. A smaller version of the receiver, using sub-miniature components, was built into a little metal cuff-link box that could be carried in a pocket.

**How It Works.** Transistor Q1 is a superregenerative detector. The resonant circuit (inductor L1, capacitor C5, and tuning capacitor C4) is tunable over the frequency range mentioned above. Capacitor C3 provides feedback for oscillation and capacitor C2 couples the signal from the antenna to the tuned circuit. Potentiometer R3 is used as the regeneration control to set transistor Q1 to the point of oscillation.

# BUILD MINI- MAXI

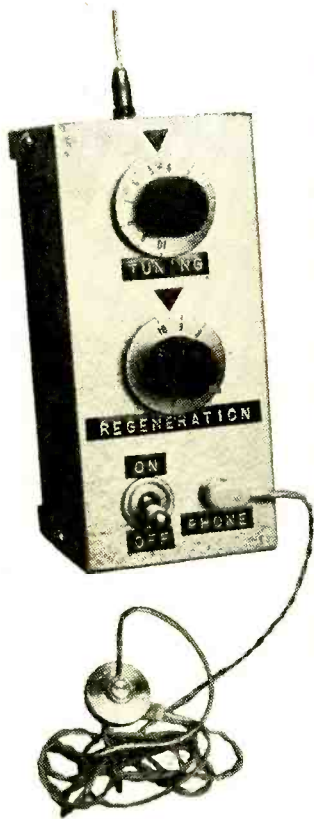

by William F. Splichal, Jr.

**A novel vhf  
superregen receiver  
that can tune in  
stations from  
50 to 200 MHz**

The audio signal developed across resistor R4 is directly coupled to the base of transistor Q2, which is in a complementary configuration with transistor Q1. Output of transistor Q2 is developed across R6 and is coupled via transistor Q3, which takes the place of a coupling capacitor between transistors Q2 and Q4. A high beta silicon transistor used for Q3 will provide a small amount of gain as well as a means of coupling transistors Q2 and Q4. The audio is further amplified by transistor Q4 and its output is applied across a suitable earphone or speaker that may be plugged into jack J2.

**Construction.** The recommended layout and wiring of Mini-Maxi as shown in the photograph can be followed provided components identical to those specified in the Parts List are used and it will fit in a 2¼ x 2¼ x 5-in. minibox. If you build the receiver in a different container, it must be a metal one to avoid hand capacitance effects detuning the receiver. Mount J1, R3, C4, S1, and J2 before wiring in the remaining components. The lead lengths on Q1, L2, C2, C3, C4, C5, and L1 should be kept as short as possible to minimize stray capacitance effects. Layout and lead length of the other components are not as critical and can be varied to suit the builder. (Turn page)

# MINI-MAXI

Transistor Q1 can be almost any pnp germanium vhf type transistor capable of oscillating at 175 MHz. Many types of small signal npn germanium audio transistors can be substituted for Q2 and Q4 with satisfactory results.

The battery is connected to a battery plug obtained from an old discharged 9-volt battery. One terminal of the plug is soldered to one of the switch terminals via a small strip of flexible metal which is insulated with tape to prevent shorting out to the box.

The 2-ft. whip antenna was made by removing the insulation from a length of #14 wire and soldering it into the end of a tip plug (P1) which will plug into J1. A more compact antenna can be made by attaching a small telescoping antenna (similar to Lafayette 18E54009) to a tip plug which will plug into J1.

Overall tuning range of the receiver can be changed by using different sizes for inductor L1. By making it with six turns in-

stead of the three previously specified, the receiver will tune from 50-100 MHz, and with two turns it will tune from 100 to 200 MHz.

**Receiver Operation.** Almost any speaker or earphone having an impedance from 4 and 2000 ohms can be connected across Mini-Maxi's output. The lower impedances will give higher output. After turning switch S1 *on*, regeneration potentiometer R3 is set by first turning it clockwise until oscillations are heard and then turning it counterclockwise until the oscillations stop and hissing is heard. Tuning capacitor C4 is then tuned to a station. The setting of the regeneration control will vary with the frequency to which the receiver is tuned and will require resetting for optimum operation. By experimenting in tuning in various type stations, the dial can be marked where the following different types of transmissions occur:

54-88 MHz	Television
88-108 MHz	FM
108-136 MHz	Aircraft
144-148 MHz	Amateur
148-175 MHz	Police and Fire

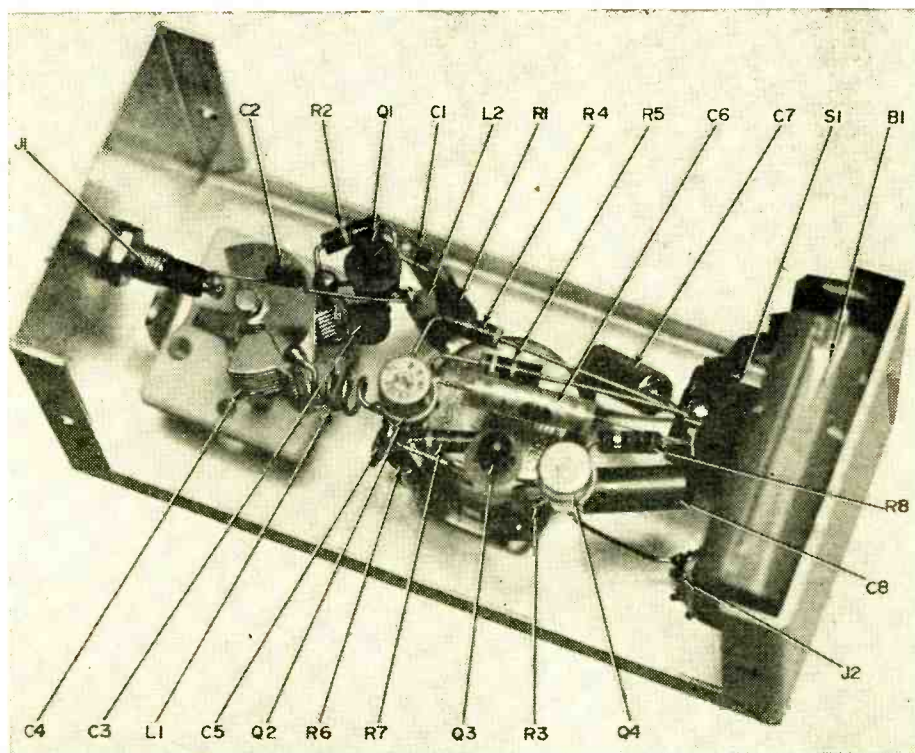

Underside view of Mini-Maxi reveals location of virtually every component it contains. Whip antenna plugs into jack J1 at left.



When receiving very strong stations, the regeneration control may have to be turned counterclockwise to reduce volume and produce an undistorted output. In some cases it may also be necessary to slightly detune the

station to reduce volume further. A nice finishing touch is to identify the controls, using press-on letters (Datak or equiv.) covered with several coats of clear, spray-on lacquer for protection. ■

### PARTS LIST FOR MINI-MAXI SUPERREGEN RECEIVER

- B1—Transistor radio battery (Eveready 216 or equiv.)
- C1, C6—15- $\mu$ F, 15-VDC electrolytic capacitor (Sprague 1152 or equiv.)
- C2—5-pF, 1000-VDC ceramic disc capacitor (Sprague 5GA-V50 or equiv.)
- C3—15-pF, 1000-VDC ceramic disc capacitor (Sprague 5GA-Q15 or equiv.)
- C4—3.7 to 52-pF variable tuning capacitor (Hammarlund HF50 or equiv.)
- C5—0.001- $\mu$ F, 1000-VDC ceramic disc capacitor (Sprague 5HK-D10 or equiv.)
- C7—50- $\mu$ F, 15-VDC electrolytic capacitor (Sprague 1160 or equiv.)
- C8—35- $\mu$ F, 15-VDC electrolytic capacitor (Sprague 1159 or equiv.)
- J1—Tip jack, nylon insulated (H.H. Smith 240 or equiv.)
- J2—Subminiature phone jack (Lafayette 99E62119 or equiv.)
- L1—3 turns #18 bare copper-tinned wire, 3/16-in. ID x 3/8-in. long (see text)
- L2—55- $\mu$ H RF choke (J.W. Miller 4629-E or equiv.)
- Q1—Pnp germanium vhf transistor

- (Sprague 2N2401) (see text)
- Q2, Q4—Npn germanium audio transistor (RCA type 2N388) (see text)
- Q3—Npn silicon, high beta audio transistor (Motorola type 2N3565) (see text)
- P1—Plug to fit tip jack
- R1—47,000-ohm, 1/2-watt resistor
- R2—220,000-ohm, 1/2-watt resistor
- R3—1000-ohm, linear taper, potentiometer (Mallory U4 or equiv.)
- R4, R7—4700-ohm, 1/2-watt resistor
- R5—3900-ohm, 1/2-watt resistor
- R6—2700-ohm, 1/2-watt resistor
- R8—1500-ohm, 1/2-watt resistor
- S1—Spst toggle switch (Cutler-Hammer 8280-K-14 or equiv.)
- 1—2 1/4 x 2 1/4 x 5-in. minibox (Premier PMC 1004 or equiv.)
- 4—Transistor sockets (Lafayette 32E42211 or equiv.)
- Misc.—Wire, solder, bolts, nuts, earphone or speaker (any low-impedance unit—see text), press-on letters or embossed tape, etc.

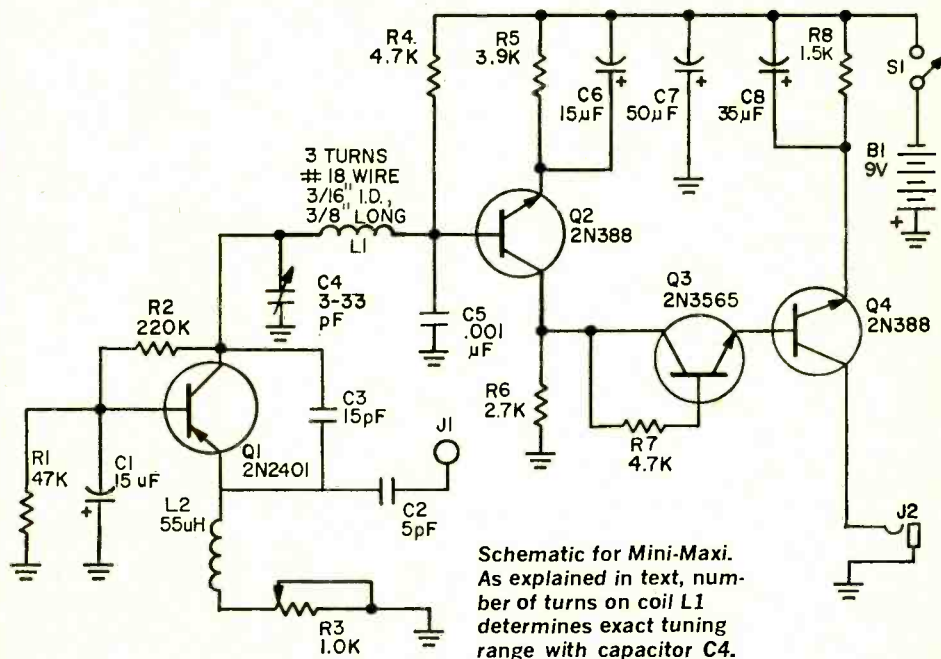

# Antiquing an Old Tube into Antiquity

by Art Traufer

Many antique radio collectors have one or more early battery radios in their collections which have bayonet shell-type sockets made for O1A type tubes. The O1A tubes require 5 volts on the filament and draw a hefty .25 amps each. Since these tubes were out of production many years ago and are becoming hard to find, it is desirable to use more modern tubes having lower filament voltages and less "A" battery drain. One such tube is the type 30 tube, which requires only 2 volts on the filament at only .060 amps!

Type 30 tubes have the same four pin arrangement as the old O1A tubes. However, the 30's base is smaller in diameter than the O1A's base and it also does not have the metal pin for use in bayonet sockets. The 30 tubes were made for use in "push-in" type sockets.

To use a 30 in an O1A bayonet socket it isn't necessary to make an adapter or to "re-tube" an O1A base with a 30 glass envelope. All you have to do is build up the diameter of the 30 base so that it fits the bayonet socket and then put small metal

pins in the base.

**How To Do It.** Buy a 12" length of Crown Line PCV-1120 1" white plastic pipe at a plumbing supply house, or buy any other plastic pipe having an inside diameter the same (or slightly larger) than the diameter of the 30 tube base. Be sure the outside diameter is the same (or slightly smaller) than the opening in the O1A bayonet tube socket.

Saw off a 1" piece from the plastic pipe, then file the tough sawed edges smooth and glue the 1" piece on the base of the 30 tube. If the plastic fits a little too loose on the tube base simply wrap a turn or two of *Mystik* cloth tape around the tube base before you apply the glue. Let the glue harden.

If the modified 30 base now fits a little too loose in the O1A bayonet socket wrap a turn or two of the cloth tape around the base.

To complete the job fasten a small metal pin in the base. To do this drill an undersize hole through the plastic and into the tube base and then twist in a machine screw

*(Continued on page 113)*

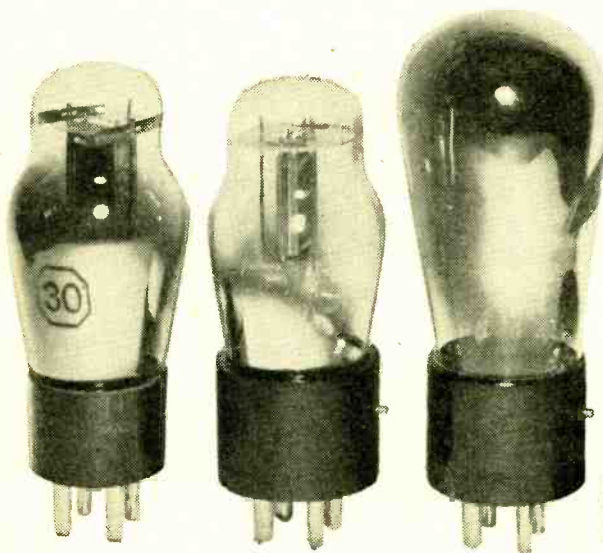

Shown from left to right are : type 30 vacuum tube unmodified, type 30 vacuum tube modified by a wider base and addition of a base bayonet pin, type O1A vacuum tube grandfather used, and last, the bayonet socket that is the cause of the problem.

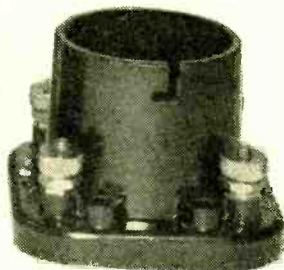

**Fabricate an O1A from a type 30 tube and keep your ancient rig on the air!**



# Hour Master... A Super Timer

Turn off to  
Electronics?

by Steve Daniels

**H**OW WOULD you like an electronic watchdog for your CB equipment, Channel 9 monitor or household appliances that will keep them turned on a specified length of time, then shut them off automatically? Could you use something to turn a TV or Stereo off at night after you've fallen asleep? What about an electric nap alarm to wake you from a snooze with music from your radio or Hi-Fi?

Well, here's one answer. It's our electronic Hour Master. Or should we say, *Your Master!* Hour Master is a wide range electronic timer and Diac-Triac full-wave speed control combined in one compact unit. It will handle literally any timing job from seconds to hours whether time-in or time-out is required. If you wish, you can even add a speed control by just adding one variable resistor to the circuit; the result is a flexibility applicable to dozens of jobs in home and shop.

**The Old Timers.** Many electronic timers up to now have been limited in length of time delay because huge capacitors were required. Hour Master can easily provide delays of an hour or more with its average

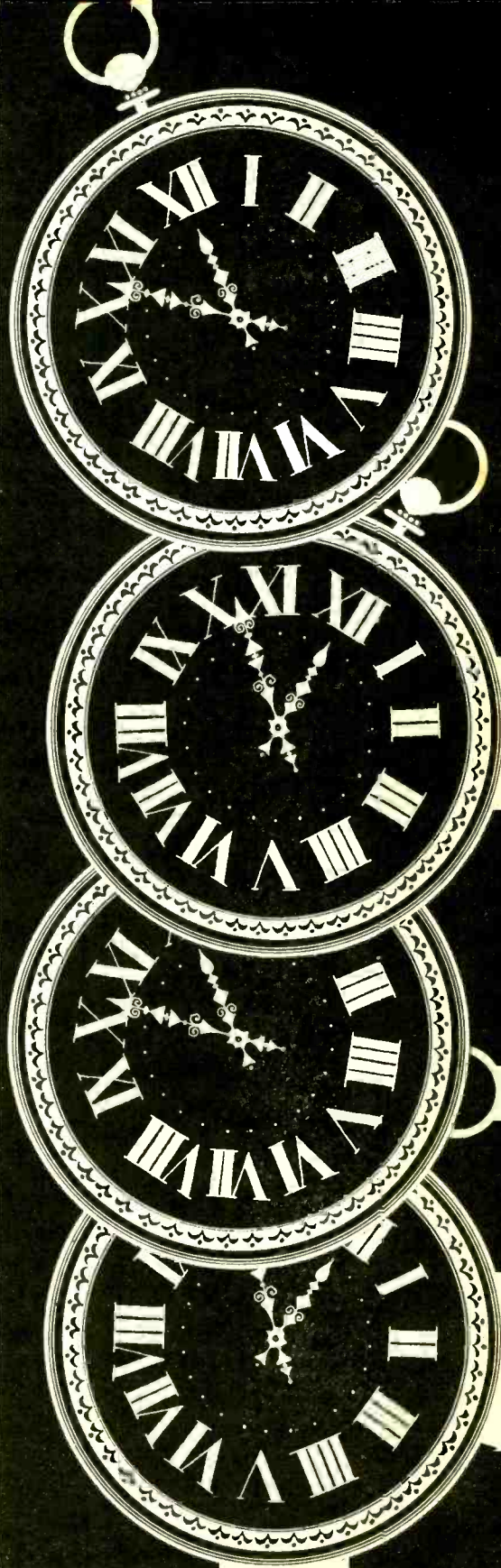

# Hour Master

sized 200 uF timing capacitor. The schematic shows how it's done. Diac D1 and Triac Q3 form a standard AC phase control which can be turned off through the contacts of relay K1. For use as a speed control, R4, a 250,000-ohm linear pot, is added as shown to points A and B. With mode switch S3 in the *out* position, you have a regular speed control. When battery switch S2 is closed, the timing circuit is armed. By pressing time-start switch S1, timing capacitor C1 is charged by the battery; when S1 is released, C1 slowly discharges through time-set pot R1 and source-follower Q1.

Time-set potentiometer R1 can be either 5 or 10 megohms. Resistor Rx sets the low limit of the timer and may be selected to

fit your needs. It was 100,000-ohms in the author's model giving him a minimum time delay of 30 seconds. Capacitor C1 may also be changed in value to modify the delay time. With a 200 uF capacitor and a 10 megohm pot, the maximum delay is well over an hour and over a half-hour with a 5 megohm pot.

**Getting Busy.** The author's model was housed in a 6¼-in. x 3¾-in. x 1⅞-in. plastic case with an aluminum panel used as the top plate of the unit. You may want to start by drilling holes in the cover for switches, pot(s), and socket. Be sure to add an extra hole for potentiometer R4 if you want the speed control feature.

Go to work on the circuit board; you can use about a 2-in. x 4½-in. piece of perforated phenolic board. Wiring is straight-forward, but keep the triac circuitry and the FET at opposite ends of (Continued on page 113)

## PARTS LIST FOR HOUR MASTER

- B1—9-volt battery, Eveready 216 or equiv.
- C1—1 to 1000 uF, 12-VDC electrolytic capacitor (see text)
- C2—0.05 uF, 600V disc capacitor
- C3—0.1 uF, 600V disc capacitor
- D1—Diac, Motorola HEP-311
- K1—Sensitive SPDT relay (Potter & Brumfield type LM5 or equiv.) (see text)
- Q1—N-channel FET, Motorola HEP-801
- Q2—NPN transistor, Motorola HEP-55
- Q3—Triac, RCA 40429
- Rx—100,000-ohm, ½-watt resistor, 10%

- R1—5 megohm to 10 megohm, linear taper potentiometer (see text)
- R2—2,700-ohm, ½-watt resistor, 10%
- R3—120,000-ohm, ½-watt resistor, 10% (see text)
- S1—SPDT pushbutton switch (Switchcraft 1002 or equiv.) (time-start switch)
- S2—SPST toggle switch (power switch)
- S3—SPDT toggle switch (mode switch)
- SO1—AC receptacle, chassis mount
- Misc.—Hardware, knobs, perforated board, flea clips, wire, solder, etc.

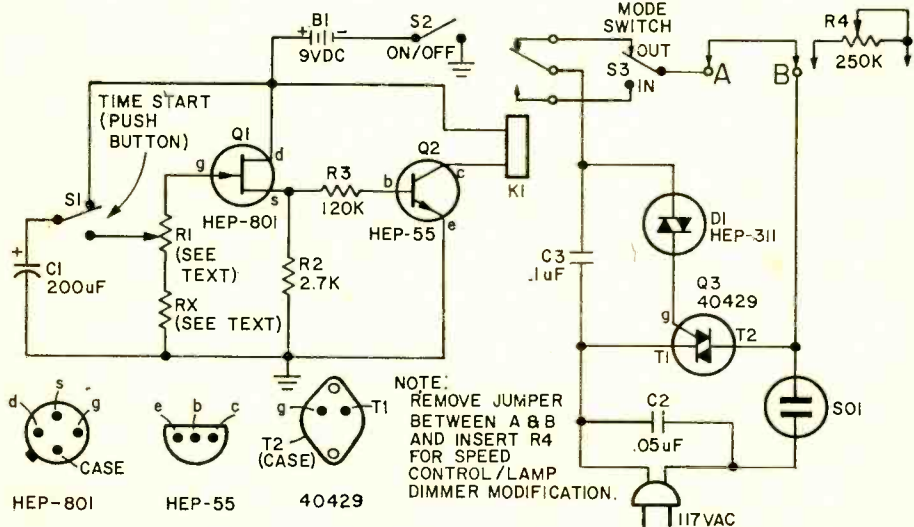



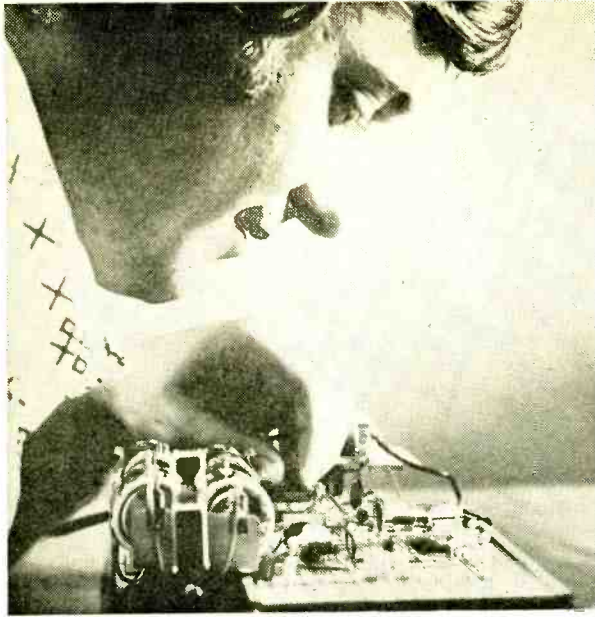

# You Learn to Make Money ...with CIE's Electronics Laboratory!

Now you can learn Electronics by performing more than 200 practical, skill-producing experiments...with authentic industrial components...at home...in your spare time.

You learn by doing! This 161-piece Laboratory includes the up-to-date equipment you'll need — such things as an IC (integrated circuit), printed circuit board, FET (field effect transistor), photovoltaic cell, DC motor, microphone, multimeter, soldering iron and power supply.

You put theory into *practice* right in your own *home*... in your spare time...while you go right on pulling down your present pay. It's CIE's exciting space-age "Electronics Technology with Laboratory" program... a unique combination of CIE's special AUTO-PROGRAMMED® Lessons and laboratory equipment. It is the *practical* way to learn Electronics!

### Prepare for a High-paying Career

You see, when you "learn by doing," you're *ready to do*...you're *armed* with the know-how to meet the challenges of a high-paying career in Electronics... prepared to go after an exciting, relevant job in a growing field such as medical technology, pollution control, radio and TV broadcasting, computers...just to name a few. Once you have some experience, you can make \$12,000 a year or more.

*But that's not all!* When you successfully complete your Electronics Laboratory course, you'll get a CIE Diploma. And, you'll be able to pass the Government FCC examination or *be entitled to a full refund of all tuition paid!* CIE's Money-Back Warranty is valid during the completion time allowed for your course.

Send today for CIE's 2 FREE BOOKS about opportunities in Electronics. For your convenience, we will try to have a representative call. Mail reply card or coupon to CIE... or write: Cleveland Institute of Electronics, Inc., 1776 E. 17th St., Cleveland, Ohio 44114.

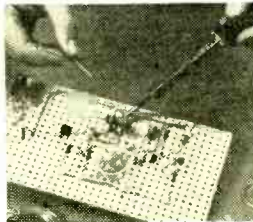

You learn how to construct circuits and connect them with a soldering iron, which is part of your CIE laboratory equipment. This "hands on" experience is extremely valuable.

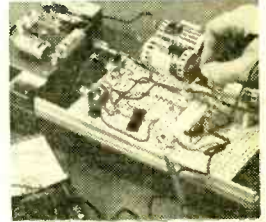

Testing and troubleshooting are an important part of your learning experience. Your laboratory has a precision multimeter to diagnose electronic troubles quickly and accurately.

### APPROVED UNDER G.I. BILL

All CIE career courses are approved for educational benefits under the G.I. Bill. If you are a Veteran or in service now, check box for G.I. Bill information.

## CIE Cleveland Institute of Electronics, Inc.

1776 East 17th Street, Cleveland, Ohio 44114  
Accredited Member National Home Study Council

Please send me your 2 FREE BOOKS — The CIE school catalog, "Succeed in Electronics" and "How To Get a Commercial FCC License."



Name \_\_\_\_\_ (Please Print)

Address \_\_\_\_\_

City \_\_\_\_\_

State \_\_\_\_\_ Zip \_\_\_\_\_ Age \_\_\_\_\_

**Veterans and Servicemen:**

Check here for G.I. Bill information.

EB-11

CIRCLE NO. 4 ON PAGE 15 OR 117

# This Disaster Alarm Can Save Your Life

by Herb Friedman

It used to be that the average homeowner wanting early warning of impending fires through smoke detection either had to go the expensive commercial-equipment route or build a not-to-reliable homebrew device. In between the two extremes was nothing on which you'd stake your life. Fact is, in most instances "Joe Average" is still being sold expensive smoke detectors for home use he'd have to throw directly into a fire before it sounded an alarm.

But times change, particularly when it comes to solid state devices, and a small *ionization detector* designed to detect gas fumes and smoke is now available for little more than the cost of a transistor. Though the device is often termed a "smoke detector" it also sniffs out carbon monoxide, methane and Iso-Butane gases, in fact, any ionized gas. A small alarm system such as the Radio Shack Disaster Alarm Kit (#28-4006) which incorporates this detector can be used as a smoke detector in the home to warn of impending fires, as a carbon monoxide detector in the garage for those of you who insist on working on a running engine with the garage doors closed, or as a gas fume detector in closed areas.

The Disaster Alarm Kit has an approximate sensitivity to carbon monoxide of 500 PPM, and 2% to 4% smoke. Unfortunately, it does not incorporate heat detection—for there can be fire before smoke. However, we'll show you how, for just pennies and two extra wires, the Disaster Alarm can be converted to a *smoke, gas, heat and burglar alarm*.

**Start With a Prefab.** The basic Radio Shack Disaster Alarm Kit is AC powered and is housed in a small white plastic cabinet that is mounted high on a wall near the bedroom area (or inside a garage or closet). The alarm sound is produced by a loud, raucous buzzer, similar to the warning horns used as interior remote fire alarm horns in commercial equipment. Once triggered, the

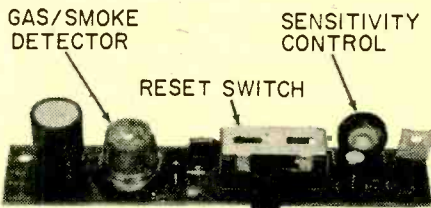

Assemble the printed circuit board exactly as described in the manual. Modifications are added to a complete and tested board.



alarm can be silenced only by operating a reset switch. Should the gas or smoke be temporarily blown away by wind the alarm will not be silenced: only the user can silence the alarm.

The kit consists of the plastic housing, power transformer, buzzer-horn, a small printed circuit board and much less than a handful of components. Construction time takes about one hour.

On the PC board is a small wire jumper labeled "J" that is used only for initial setting of a sensitivity control. After the sensitivity is adjusted the J-jumper is normally cut through. However, by bringing out the two J-jumper connections to a screw type terminal strip positioned near a hole pre-drilled on the alarm's back panel both fire and intruder detectors of the *open circuit type* can be connected into the Disaster alarm. Thus, the buzzer-horn sounds when there is gas, smoke, excessive heat or a forced entry through a door or window.

The alarm must be completed and tested before the fire/intruder modification is made. Only after you are *absolutely certain* the alarm is working properly should the following modifications be added to the alarm.

**Fire-Intruder Modifications.** The PC board is held to the cabinet by three plastic studs. Gently snap the board off the studs and flip it over. Unsolder the J-jumper which is now cut in two. In its place solder a 6 in. pair of insulated twisted wires. Then, re-install the board on the studs. Position a two terminal strip so it half covers the "extra" hole in the cabinet's rear cover, mark the mounting holes and drill for #4 or #6 screws. Bend the terminal strip's solder lugs outward so they will be horizontal to the cabinet and install the terminal strip using

POWER TRANSFORMER    TERMINAL STRIP

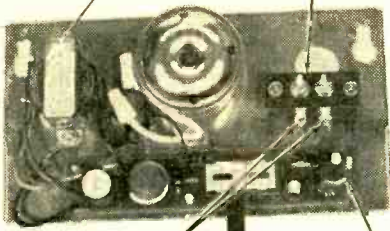

J-JUMPER WIRES    PRINTED CIRCUIT BOARD

Best location for alarm is high up in the bedroom area. Make certain resetting switch points down so that it is very convenient.



## DISASTER ALARM

a 1/2 in. spacer or stack or washers between the terminal strip and the cabinet. (You must be certain the terminal strip does not short to the metal cabinet cover.) Solder the two wires from the J-jumper connections to the terminal strip. That's the entire modification.

The Disaster Alarm will work normally with or without connections to the terminal strip. If you connect *open circuit* type heat and fire intruder detectors (such as magnetic switches) to the terminal strip the alarm will sound when ambient heat is excessive or when an intruder forces a door or window.

The heat and intruder detector switches are connected in parallel as shown in the schematic diagram. Because it's a parallel connection there is no practical limit to the number of protective devices you can use. You can place a heat detector in every room and a magnetic switch on every window. Heat detectors come in two standard values: 135°F which is used in the living areas and 190°F (or 195°F) used in furnace rooms and attics.

Take extreme care that you do not obtain *closed circuit* detectors for these cause the alarm to continuously sound. The magnetic detector usually sold in electronic parts stores is the closed circuit type. Do not let a salesman talk you into these devices. The heat and magnetic switch specified as *open circuit* has its contacts *open when safe* and *closed when activated*. If you or the salesman are in doubt as to whether you are getting the correct detector simply check it out with an ohmmeter. Open circuit detectors are usually available from security equipment distributors and many electrical supply houses.



Standard open circuit heat/fire detectors can be installed in all living areas, above the furnace and in cellar and attic.

**Final Set-up.** After your complete security system is installed, check it out in the following manner. Blow some cigarette smoke at the alarm. If the alarm doesn't trip calibrate the unit as specified in the supplied instructions, but where the instructions call for a J-jumper simply connect a clip lead across the terminal strip. Similarly, where the instructions call for cutting the J-jumper just remove the clip lead.

Applying a match near the heat detector should sound the alarm. If it doesn't you have made a wiring error. (As soon as the detector cools off it automatically resets itself.)

Check a magnetic switch by opening the door or window. If the alarm doesn't sound, look for a wiring error.

It is a good idea to periodically check the system by deliberately tripping each detector—contacts do go bad. If you discover an inoperative detector replace it immediately. ■

The alarm system with modified circuits can have any number of additional detectors added to expand system to cover the entire house, even the garage. Terminal strip is added, after alarm is built, in place of jumper "J".

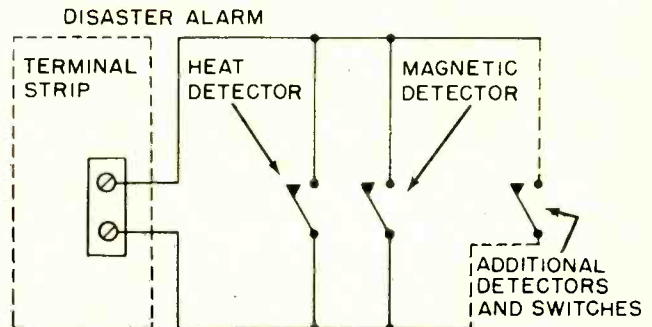



Your axe swings to a different beat with a six buck gizmo we call . . .

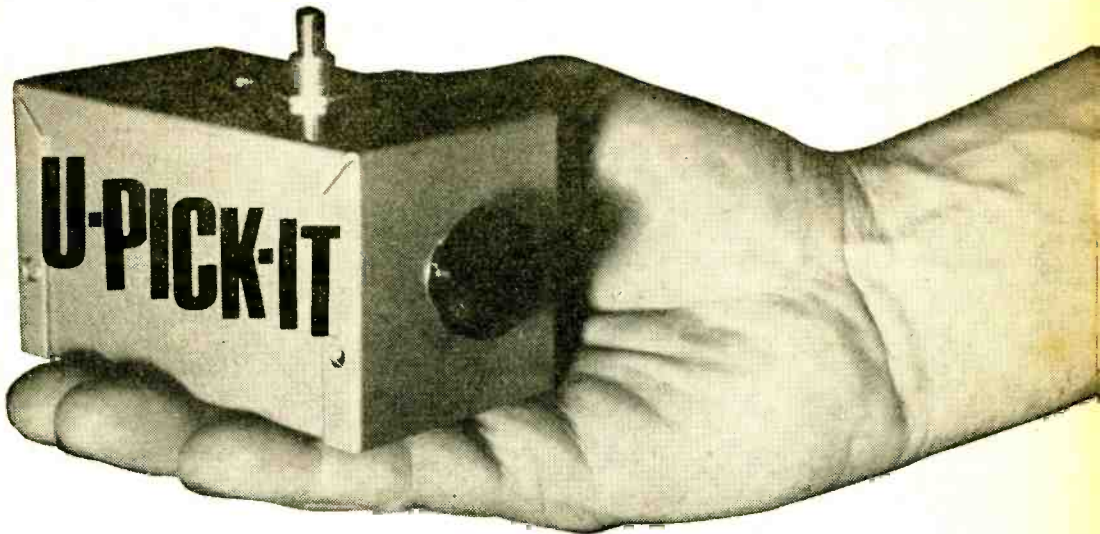

by Steve Daniels, WB2GIF

Would you spend about six bucks to tailor the sound of your guitar? Especially if you knew you'd have the great sound of that group you know is heading to the top. Or, maybe, you're not satisfied with the sounds you're getting, and want to be able to change the tone of your guitar to suit the mood of your music. We're not saying that our *U-Pick-It* will make a Segovia out of you. But it sure will make your guitar sound great, and who knows, maybe it will help you on to fame and fortune.

What does *U-Pick-It* do for your instrument? It gives you a choice of bass, treble or midrange boost just by turning a single knob. You can make that old guitar sound

twangy, smooth or raunchy at the twist of your wrist. Furthermore, *U-Pick-It's* bass boost will allow a regular guitar to be used as a string bass by giving those low notes an extra boost.

**PSO With a Difference.** Check the schematic; it will ring a bell for many of you. Basically, you'll see a phase shift oscillator with a few necessary changes. Note the network consisting of components R1, R2, and R3 isolates transistor Q1 from the loading effect of the guitar pickup. Also, potentiometer R6 is used to lower the stage gain to the point where the transistor will be amplifying rather than oscillating. The phase shift network peaks the response within a

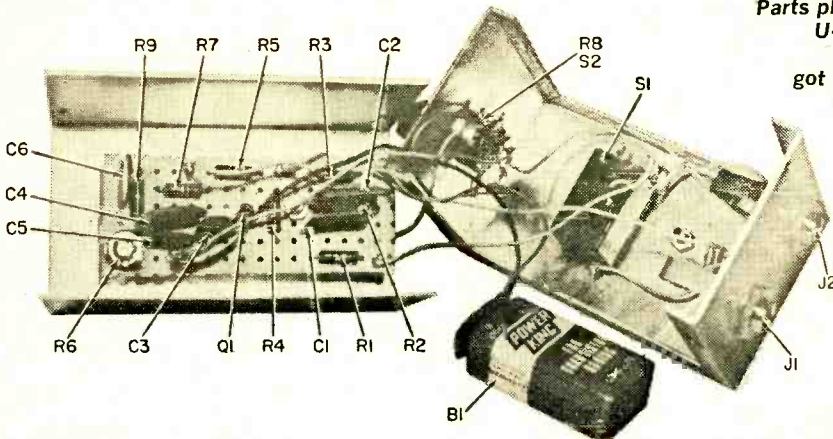

Parts placement within *U-Pick-It* presents no problems got choice of switch S1 in Parts List.

# U-PICK-IT

fairly narrow range, depending on the setting of potentiometer R8.

**You Pick its parts.** We housed *U-Pick-It*, including its own self-contained battery power supply (a 9 V transistor battery) in a 4 X 2¼ X 2¼-in. Minibox. All of the components with the exception of the input and output jacks, the *IN-OUT* switch, potentiometer R8 and the battery are mounted on a 3¼ X 1¼-in. piece of perfboard. Push-in clips are used for input, output, battery + and ground terminations.

Although the transistor doesn't have the usual triangular pin orientation, if you follow our layout, it can be mounted without having to cross over any of its leads. A word of caution now: this circuit won't work with low gain transistors. So please,

no substitutions! Besides, the one we used isn't expensive, so there really isn't a good reason to fiddle with dime-a-dozen transistors.

In the phase section, use good quality disc capacitors rated 50 VDC minimum or better. Seems we found that low voltage ones sometimes may leak too much for this application.

Drill mounting holes for the two jacks in one end of the bottom half of the Minibox. Whether you buy a commercial battery holder, or make one from a scrap of aluminum, locate the battery so that it will clear the other components when the Minibox is closed. Drill two mounting holes; one for the battery holder, and the other to support the perfboard that's raised ¼-in. off the bottom with a spacer.

*IN-OUT* switch S1 is located in the center of the top half of the Minibox. It's a push-  
(Continued on page 112)

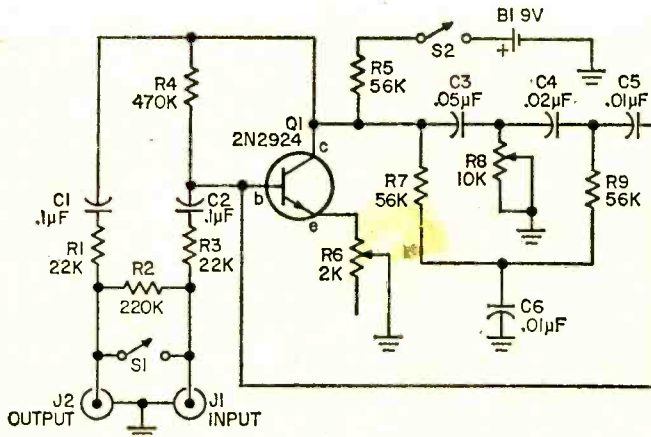

## PARTS LIST FOR U-PICK-IT

- B1**—9 V transistor radio battery (Burgess type 2U6 or equiv.)
- C1, C2**—0.1 µF, 75 V ceramic disc capacitor (Lafayette 33F69089 or equiv.)
- C3**—0.05 µF, 75 V ceramic disc capacitor (Lafayette 33F69071 or equiv.)
- C4**—0.02 µF, 75 V ceramic disc capacitor (Lafayette 33F69063 or equiv.)
- C5, C6**—0.01 µF, 75 V ceramic disc capacitor (Lafayette 33F69055 or equiv.)
- J1, J2**—Standard open circuit phone jack (Lafayette 99F2135 or equiv.)
- Q1**—Silicon, npn, high gain transistor (GE type 2N2924 or Motorola HEP 724)
- R1, R3**—22,000-ohms, ½-watt, 10% composition resistor
- R2**—220,000-ohms, ½-watt, 10% composition resistor
- R4**—470,000-ohms, ½-watt, 10% composition resistor
- R5, R7, R9**—56,000-ohms, ½-watt, 10% composition resistor
- R6**—2,000-ohms potentiometer, ¼-watt, linear taper (Lafayette 33F16452 or equiv.)
- R8**—10,000-ohm potentiometer, 1-watt, linear taper (Lafayette 33F11255 or equiv.)
- S1**—Spst rocker switch (Lafayette 34F34164 or equiv.) See text
- 1**—4 X 2¼ X 2¼-in. Minibox (Lafayette 12F83878 or equiv.)
- 1**—Battery holder (Keystone #203P or equiv.)
- 1**—Battery connector (Lafayette 99F-62879 or equiv.)
- 1**—3¼ X 1¼-in. piece of perfboard
- Misc.** Wire, solder, bolts, nuts, spacer, knob, push-in pins, etc.



# ELECTRONICS HOBBYIST

Connect this novel circuit to your FM receiver, and listen to police and fire calls, weather, marine, emergency services!



TUNE IN  
THE ACTION  
WITH

## VHF HIGH-BAND CONVERTER

by Charles Green

Cliff-hanging emergencies, weather forecasts, ham QSQ's, law enforcement patrols in action, mobile radio telephones—two-way broadcasts make listening to the VHF High Band an ever-changing adventure. Our VHF High Band Converter covers from 135 to 175 MHz, and it pulls in public safety, industrial, marine, land transportation and the 2-meter ham band signals.

You can listen to the VHF High Band with our compact converter, which connects to an FM-band home broadcast receiver. The converter uses a dual-gate FET and a UHF-type transistor in a simplified solid-state circuit. The components are housed in a 4 x 4½ x 2½-in. aluminum cabinet, with perf-board construction for ease in building. You can build it—start today!

**About the circuit.** Signals from the antenna are connected via J1 to the L1-C1 tuned circuit, and fed to gate 1 (g1) of the dual-gate FET mixer Q1. Gate 2 (g2) of Q2 is coupled via C2 to the oscillator circuit of Q2.

C11 tunes L3 (and the Q2 oscillator circuit) 88 MHz above the incoming signal frequency. The oscillator RF output is coupled via C2 to the Q2 Gate 2 (g2) and mixed with the incoming signals. The resultant 88-MHz RF output (the difference

# VHF HIGH-BAND CONVERTER

*Placement of components is critical, due to high-frequency operation. L3 is a U-shaped coil, as shown in the schematic on the opposite page.*

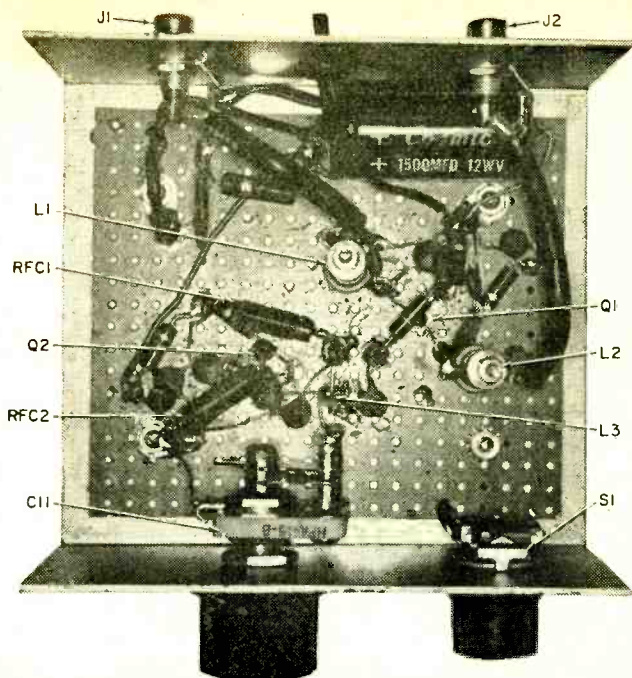

frequency between the signal and the oscillator) is fed from the Q1 drain (d) to the C5-L2 tuned circuit, and then to J2 and the FM-broadcast receiver.

The required DC power for the converter circuits is supplied by the PSI 9-volt supply, and additional filtering is accomplished by R4-C8.

**Construction.** The VHF converter is built in a 4-in. deep x 4½-in. wide x 2 ⅝-in. high aluminum cabinet. Most of the components are installed on a 3⅜-in. x 4-in. section of perforated board, with the remaining parts mounted on the front and rear cabinet panels. Because of the high-frequency operation, the component placement is critical. For best performance, follow our component layout as shown in the parts layout photo.

Variable capacitor C11 must be modified before installation. Remove rotor and stator plates until one rotor and one adjacent stator plate remains. Start construction by mounting C11 and S1 on the front panel in the same positions shown in the photo. Cut the PSI cable hole and mount J1 and J2 on the rear panel. Mount the 3⅜-in. x 4-in. perforated board section on the box bottom with ¼-in. metal spacers at each corner.

Fabricate L3 from a length of No. 18 bus wire as shown in the schematic diagram, and

mount with push-in clips close to the stator of C11. Make the connection between the C11 stator and L3 with a short length of No. 22 bus wire, then mount the oscillator circuit of Q2 and associated components closely around L3 as shown in the photo.

Position coils L1 and L2 and mount them inverted with push-in clips and short bus leads soldered to the coil terminals. Mount and wire the remaining circuit components as shown in the schematic diagram. Q1 is mounted inverted with short-leads connected to push-in clips. Do not remove the shorting wire supplied by the manufacturer until all the wiring of the converter unit is completed. Use short lengths of RG-58A coaxial cable to connect the primary wind-

## Suggested Frequencies for Listening

Service	Approx. Freq. (MHz)
2-Meter Ham Band	144-148
Tow Trucks	151
Taxicabs	152
Telephone calls	153
Fire	154
Police	155
Marine	157
Trucks	160
Weather	162



ing of coil L1 to J1, and the secondary winding of coil L2 to J2. These primary and secondary windings are made of one turn of No. 22 hookup wire, and are wound around the center of each of the L1 and L2 coils. Make all wiring as short and direct as possible, except the leads to S1. Position the S1 leads under the perf board and close to the box bottom.

**Alignment and Calibration.** Tune your FM receiver to a selected clear frequency at the low end of the band (our receiver was tuned to 88 MHz), and connect the converter's J2 to the receiver external antenna and ground terminals. Use coaxial cable for best results. If the receiver does not have

external antenna and ground terminals, wind one turn of hookup wire around the antenna loopstick and connect these leads to the coaxial cable to J2. Be sure that there is no connection to the chassis of a transformerless (AC-DC type) receiver to prevent possible electrical shock. Connect P1 to the AC line and set S1 to ON.

Connect a signal generator to J1, and adjust the generator controls for a 150-MHz modulated output. Most FM receivers employ a ratio detector and will detect a strong AM modulated signal. Therefore, a standard AM-modulated signal generator will be OK for alignment of this converter. Adjust C11 until you hear the signal in the FM receiver,

### PARTS LIST FOR VHF HIGH-BAND CONVERTER

- C1,C2—5.25-pF, 12-volt ceramic disc capacitor  
 C3,C4,C6—300-pF, 12-volt ceramic disc capacitor  
 C5—27-pF, 12-volt ceramic disc capacitor  
 C7,C16—500-pF, 12-volt ceramic disc capacitor  
 C8—1500-uF, 12-volt electrolytic capacitor  
 C9,C10—5000-pF, 12-volt ceramic disc capacitor  
 C11—Modified Hammarlund HFA-15-B (original capacity 2.8 to 16 pF), plates removed to leave 1 rotor and 1 stator (see text). Lafayette 40F28411 or equiv.)  
 C12,C13,C14—200-pF, 12-volt ceramic disc capacitor  
 C15—3.3-pF, 12-volt ceramic disc capacitor  
 J1,J2—Phono jacks  
 L1—0.088 to 0.12-uH coil (J. W. Miller 20A107RB1 or equiv.)  
 L2—0.108 to 0.18-uH coil (J. W. Miller 20A157RB1 or equiv.)

- L3—see text  
 P51—9-volt DC power supply (plug-in module type) (Calectro N4-057 or equiv.)  
 Q1—3N141 field-effect transistor (RCA)  
 Q2—HEP-56 transistor (Motorola)  
 R1—120,000-ohm, 1/2-watt resistor  
 R2,R3,R5,R8—220-ohm, 1/2-watt resistor  
 R4—51-ohm, 1/2-watt resistor  
 R6—10,000-ohm, 1/2-watt resistor  
 R7—4700-ohm, 1/2-watt resistor  
 RFC1,RFC2—0.82-uH RFC (J. W. Miller RFC-220 or equiv.)  
 S1—SPST rotary switch (Calectro E2-159 or equiv.)  
 MISC.—4x4 1/2 x 2 3/8-in. aluminum cabinet (LMB 442 or equiv.) perforated board, push-in clips, 1/4-inch metal spacers, No. 18 and 22 bus wire, hookup wire, knobs, ground lugs, RG-58A coax.

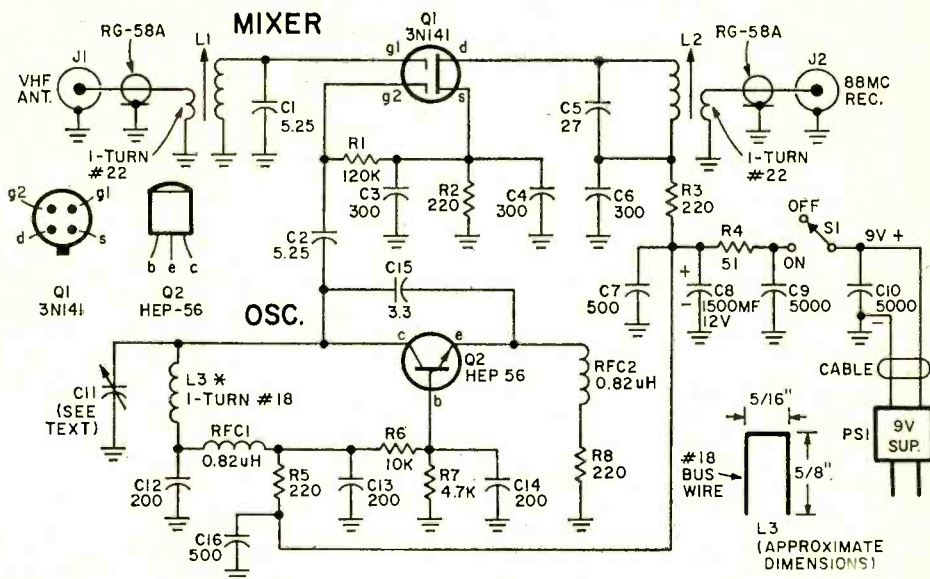

# VHF CONVERTER

then adjust L1, L2 for maximum signal. Tighten L1 and L2 tuning screw nuts.

Tune C11 from maximum to minimum capacity, and calibrate the converter dial with the signal generator. Our converter unit is calibrated from 135 MHz to 175 MHz. The tuning range is dependent upon the circuit wiring and size of L3. If necessary, change the size of L1 to cover the range.

**Operation.** For best signal reception, use a ham 2-meter ground-plane antenna, or a

commercial antenna that is designed to cover the 135 to 175 MHz range. The antenna should be mounted as high as possible, with a coaxial cable feed to J1. A whip antenna can be used to receive strong local signals.

The reception sensitivity and selectivity is dependent upon the FM receiver used with the converter unit, and a stable drift-free receiver is best for long-term monitoring. Generally, a transistorized FM receiver should be best. It can be tuned as a band-spread dial to separate crowded FM signals. Signals may not be on constantly, so tune slowly and monitor each frequency for a considerable length of time. ■

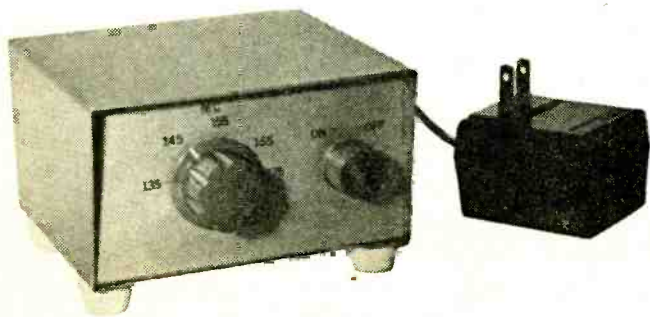

The converter gets its power from a 9-volt plug-in module, which simplifies the construction.

## REGULATED 9-VOLT POWER SUPPLY

Providing 9 volts at approximately 250 mA, this lab-type power supply will handle many experimenter projects including the VHF high-band converter above. Actually, T1 can be a 6.3-V imported filament transformer since they usually give approximately 12-V peak at less than 500 mA output. Change the Zener diode to 12 or 6 volts (and possibly the value of R1) and you get a regulated 12- or 6-volt supply. For 12 volts, use a 12-V filament transformer. Filtering is very good since the equivalent capacitor equals the value of C2 times the gain of G1. It can add up to thousands of uFs. For lab use, put in an aluminum cabinet.

### PARTS LIST FOR REGULATED 9-V POWER SUPPLY

- C1—500-uF, 25-VDC electrolytic capacitor
- C2—100-uF, 15-VDC electrolytic capacitor
- D1—Motorola HEP-175 50-PIV diode bridge rectifier
- D2—Motorola HEP-104, 9.1-V Zener diode
- Q1—Motorola HEP-240, 10-watt npn transistor
- R1—560-ohm, 1/2-watt resistor
- T1—12-V filament transformer (see text)
- I—Aluminum cabinet, select size to fit components or wire into existing project
- Misc.—Wire, hardware, perfboard, line cord, solder, on/off switch optional, etc.

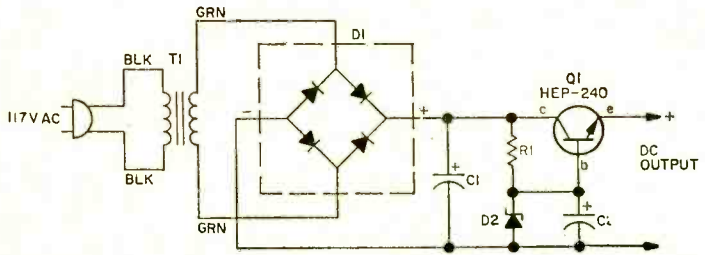

Most of the heat generated by this circuit comes from the iron losses in T1. Be sure to allow for a few vent holes above and below T1. An on/off switch may be added to T1's primary circuit.



# INSTANT PATCH BOX

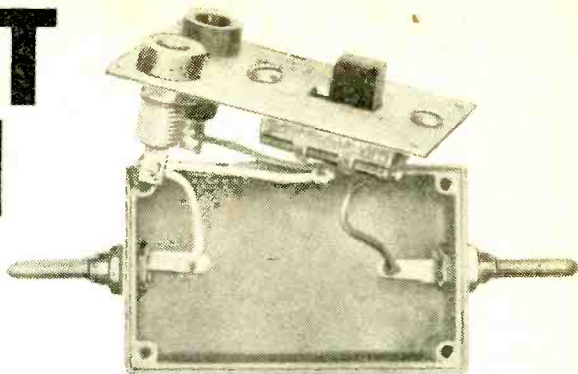

Speed up  
substitutions with this builders aid

by James A. Fred

The INSTANT PATCH BOX is one of the little luxuries that simplifies electronic experimenting and makes it more enjoyable. Haywire lash-ups often get the job done, but feedback, oscillation, or inaccurate meter readings sometimes make the end results worthless. This little blue box provides a shielded, no-nonsense method of substituting resistance, capacitance, or inductance into a circuit with a minimum of problems.

Essentially, the INSTANT PATCH BOX consists of a small metal box with a cover in which are mounted a SPST slide switch, two banana jacks, and two banana plugs. The box is the smallest that will do the job and keep distributed capacitance and inductance to a minimum. The circuit is extremely simple as you can see from the schematic diagram. A voltage is fed into one banana plug and either through the switch or through the component plugged into the banana jacks. The switch allows conduction through the plugged-in compo-

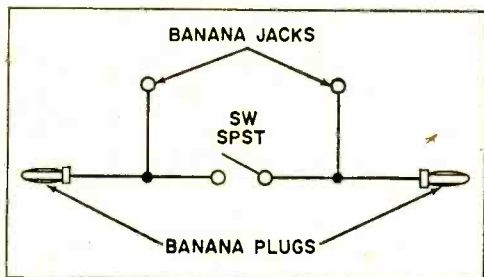

nent, or provides a shorted path across the banana jacks.

You will not find a parts list with this

article since you should select parts to fit your needs. Check your junk box for parts on hand, and pick up what you can't find at your local electronics shop.

When . . . you have built the instant patch box, what can you do with it? Let us suppose for a minute you have an experimental circuit you are working on. You are trying to determine the correct size bias resistor to use. Connect the box into the circuit with the banana jacks and alligator clips. You can now plug different size resistors into the banana jacks and short out the jacks if you wish. All this is possible without touching a soldering iron to the circuit. Once you get into the habit of using this builders aid, you may wonder how you got along without it!

Construction is simple. Secure the parts listed, make the proper size holes, and mount the parts. There is only one precaution to take and that is to be sure to use insulating washers when mounting the ba-

This almost too easy circuit gives you the option of (1) adding an extra component to your haywire circuit or (2) shorting across the component at the flip of a switch. You can vary the terminals to suit your needs.

nana plugs. They must not short to the metal box.

Incidentally, you don't have to use the same combination of input plugs or component jacks that I did. You can use 5 way binding posts, BNC connectors, tip plugs and jacks, or other types of hardware. Just be sure and use connectors that are compatible with your other test equipment. ■

# COMPASS GALVANOMETER

by T. A. BLANCHARD

Many electrical measuring instruments today are based on the design of the d'Arsonval *String Galvanometer*, but substitute a needle-suspended coil riding on jeweled bearings for the hanging coil employed in the original precise lab instrument.

The galvanometer is not often used to measure quantity of current flowing in a circuit, but rather to indicate the polarity and presence of small currents by comparison to null methods. The compass galvanometer (made from the illustration at right) can be used with a Wheatstone bridge to indicate null points.

The d'Arsonval instrument suspends a small coil between the pole faces of a permanent *horseshoe* magnet. When a current flows through the coil it becomes an electromagnet and its *like* poles repel the *like* poles of the horseshoe magnet, thus causing the coil to turn on the connecting wire. The strength of the current through the coil determines the extent of the coil's rotation.

A small pointer attached to the moving coil registers on a curved dial, or a tiny mirror is attached to the galvanometer string. A beam of light is aimed at the mirror, bouncing the beam off to a wall screen or chart to give great magnification of tiny current changes in a darkened room.

**Making A Simple Galvanometer.** A small amount of insulated magnet wire, any Boy Scout pocket compass and a 2¼ x 3½-in. scrap of plywood is what you need to make the compass galvanometer. Cut a strip of cardboard ¾-in. wide and 3¾-in. long. Score the cardboard ¾ in. from each end, with a dull knife blade and crease so the cardboard form resembles a C or bridge shape. Now glue the cardboard to the edges of the wood base. Do not use tacks!

Bind the cardboard with a rubber band until glue or cement dries. Wind 25 turns

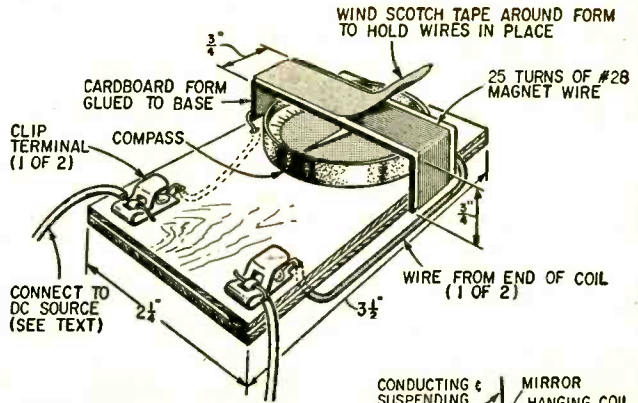

Easy to build, the compass galvanometer (above) can be assembled in an hour at practically no cost. At right is hanging coil galvanometer used in labs.

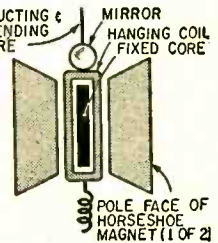

of #28 magnet wire around the cardboard. Heavier wire and fewer turns will work, too, with a slight drop-off in sensitivity.

Scotch tape is wound around the finished coil to keep the wire turns in place. Connect the ends of the coil to screw terminals or clips. Slip the compass under the coil in a position where its needle comes under the coil and parallel to the coil turns.

Connect the galvanometer in series with a flashlight battery and bulb, a buzzer or a toy motor, etc. When the circuit is closed, the compass needle will be drawn so that it is at right angles to the coil. A slow swing of the needle indicates the circuit is drawing little current. A rapid swing denotes an increase in current flow.

To show how sensitive this simple galvanometer is, connect what appears to be a dead flashlight cell across the terminals, immediately breaking the circuit. The compass needle will spin at a merry clip, indicating there is still some life in the "dead" cell.



# MAGIC -MIKE

Use it with any FM set  
connected to your PA!  
No mike line needed!

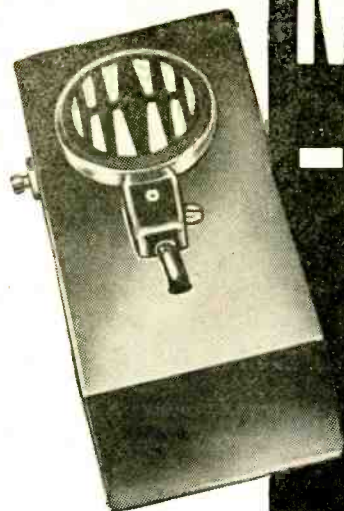

by Steve Daniels  
WB2GIF

When the FCC opened the FM band to permit legal use of low-powered transmitters for wireless microphones, telemetering and for measurement, they opened a Pandora's Box for many an experimenter. Within the short space of time after the FCC relaxed their regulations, there was a flood of flea-power devices on the market. Some were good, some bad, but most had one basic inherent problem. Body capacity affected the tuning of the device, which, in turn, affected its usefulness.

No doubt about it. For a speaker or performer to be completely free of a fixed position—dictated mostly by the best location for a floor microphone in a PA system—is probably the dream of all would-be orators and very-off-Broadway thespians. So, as soon as the new wireless microphones were introduced, there was a rush to try them out.

It didn't take long before it was discovered that this ideal device was not so ideal. Problem was, when tuned up on the bench, the little devils worked perfectly. But, after the bench tune-up, when concealed in the clothing of a voluptuous young chick, or, for that matter, an uninteresting looking gentleman, the tuning was off.

Just by walking or breathing, the signal quality, as well as its output level changed,

and so at times there was poor sound. Or, no sound at all! This is very disturbing for any performer whose roller-coaster voice levels causes the audience to loose a tomato/egg barrage!

**Simple Magic.** Our *Magic-Mike* certainly solves the tuning problem and so ultimately solves the major drawback of this equipment. You may well ask what makes *Magic-Mike* so different, especially when we note that a commercially-produced transistorized oscillator is used to generate the signal? Secret is, we added an FET (Field Effect Transistor) buffer stage to the output of the commercial unit. That isolated the tuned elements of the oscillator from the antenna and thereby eliminated the problem of body capacity disturbing the tuning of the oscillator. This buffer stage is comprised of components R1, C1, C2, L2 and Q1. These are wired as an RF amplifier. Transistor Q1 is an *n* channel FET operating in a positive ground circuit which may appear to be a bit unusual.

**Microphone Making.** Sure, you could wind coils and assemble transistors, resistors and capacitors together into a basic oscillator. But if you're like us—a little on the lazy side—it's much simpler, and cheaper, to buy a commercially-built unit to start your proj-

# MAGIC MIKE

ect. We used an Archer model 277-205 FM Wireless Microphone. It's available through *Allied Radio Shack* sales outlets. The module's easier to work with if you use just the printed circuit board without the housing.

Start your module mashery by prying off the bottom plate of the Archer module and removing the printed circuit board with its components from the housing. We mounted this circuit board, along with a  $\frac{3}{4}$  X  $1\frac{3}{8}$ -in. piece of perfboard (on which the buffer stage components are mounted) and the battery, microphone element and power switch into a 4 X  $2\frac{1}{8}$  X  $1\frac{5}{8}$ -in. bakelite utility case supplied with aluminum cover panel.

Drill mounting holes for the switch, the microphone, the antenna, the circuit board, and the battery clamp in the plastic utility case. You can see the arrangement we used in the photos. The layout isn't critical; however, we suggest you use the basic arrangement shown in the photos to simplify the construction project.

The crystal lapel microphone was fitted with a metal spring clip that can be bent to pass through a hole in the bakelite face of the utility cabinet. The clip's then crimped to hold the microphone in position. A scrap of aluminum was pressed into service as a battery clamp, holding it tightly inside the case.

The perfboard is mounted on two 6-32

machine screws with  $\frac{1}{4}$ -in. spacers raising it off the surface of the case. The printed-circuit board is suspended from the perfboard by soldering a stiff solid wire lead and capacitors C1 and C2 to circuit connecting points between them.

**Buffer Stage Assembly.** Drill mounting holes in the perfboard to match the spacing of the mounting bolt holes you drilled in the plastic case. Mount three push-in pins on the free end of the perfboard for mounting and making connections to the FET (Q1). Resistor R1 is mounted between the pins that connect to the *gate* (g) and *source* (s) pins of Q1.

Next comes coil L2, which is made by winding 3  $\frac{1}{2}$  turns of #22 bare copper wire on a  $\frac{3}{16}$ -in. diameter. Use a  $\frac{3}{16}$  in. diameter dowel rod to form the coil. After it's wound, spread it out and solder the antenna lead to the center turn. When these operations have been completed remove the dowel rod and discard it. After winding the coil the turns should be spread apart so that total length of the coil is  $\frac{5}{16}$ -in.

Solder coil L2 directly to the leads of capacitor C2 and cut off any excess coil lead wire. One end of C2 is connected to the drain (d) of Q1, and the other end is soldered to the 9V plus terminal on the printed circuit board that connects to the center tap of the coil (L1) on this circuit board. Except for the minus battery lead which is run from one side of the power switch to the *source* (s) terminal of Q1, the buffer stage is now finished.

The only other connections required to complete the project are your microphone and the plus battery leads. The shielded microphone cable supplied is cut to a length of about 2-in. Skin back the shielding about  $\frac{1}{2}$ -in. Then connect the center lead of this cable to the proper tab on the Wireless Mike module printed circuit board. The shield of the mic cable is soldered to the ground bus at this same end of the pc board.

The 9V battery connector is soldered to the assembly so that the red wire (plus lead) is connected to the tab on the printed circuit board where you connected C2. The black lead (minus lead) is soldered to one side of the power switch.

Now that the hard (?) work has been completed, there's little left to do. Fasten the perfboard assembly and printed circuit board to the case. Then mount S1 into the hole you drilled for it, insert the battery and you're ready to test *Magic-Mike*.

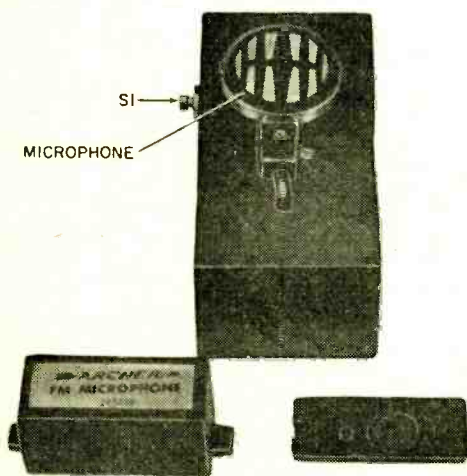

Heart of our Magic-Mike is FM wireless mike module shown with its cover on. We removed pc board from case to make easier assembly.



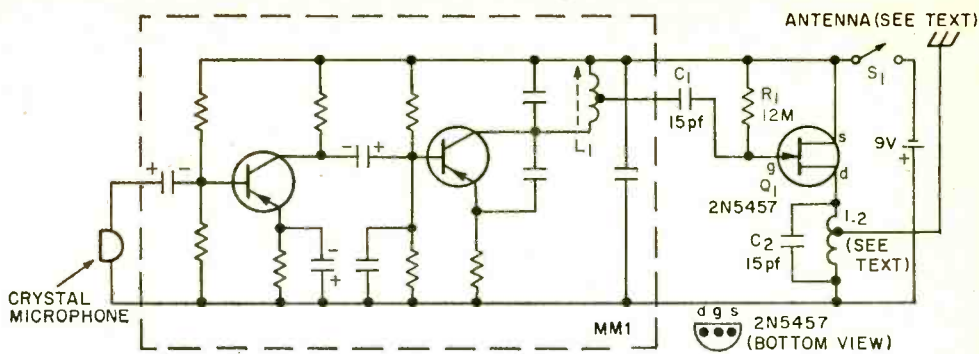

### PARTS LIST FOR MAGIC-MIKE

- B1**—9V Battery (Eveready 216 or equiv.)  
**C1, C2**—15 pF, 1000V ceramic disc capacitor (Lafayette 32F01514 or equiv.)  
**L2**—3½ turns #22 bare copper wire (see text)  
**MM1**—FM wireless microphone module (Allied Radio Shack 277-205 or equiv.—see text)  
**Q1**—n channel FET, Motorola MPF103 or HEP 801 or 2N5457  
**R1**—12,000,000-ohm, ½-watt carbon resistor

- 1**—4 X 2½ X 1½-in. plastic mini utility box with aluminum panel (Lafayette 99F80780 or equiv.)  
**1**—Battery connector (Allied Radio Shack 270B325 or equiv.)  
**1**—Crystal lapel microphone (Allied Radio Shack 33B100 or equiv.)

**Misc.** Wire, solder, bolts, nuts, spacers, perfboard, push-in terminals, aluminum strip for battery clamp, etc.

One thing not mentioned—the antenna discussed above—is soldered to the center tap of coil L2. It should be made from a piece of #22 stranded wire about 18-in. long. You might try points other than the exact physical center of coil L2 as the final connection point for the antenna. A spot a little ahead or perhaps behind the midpoint may produce a better signal.

So okay, already, how does a smart operator like you groove on *Magic-Mike*? Just follow the

instructions that come with the Archer module! We haven't changed the module's basic how-it-works principles. All we've done is to provide a means of eliminating one of the principle drawbacks inherent in all of these units. Namely, the problem of a chick's body capacity broadly detuning the oscillator. ■

*It's easier to follow our layout although circuit isn't critical. If you want to make it small enough to hide in performer's clothes go ahead and try it. The case we used may be a little too deep.*

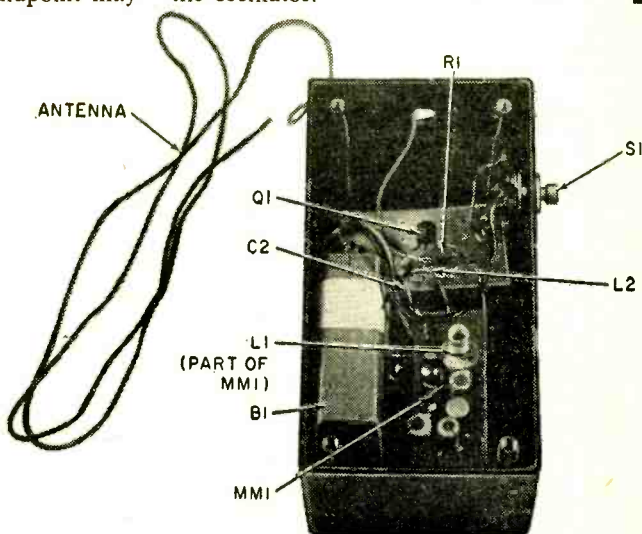



# **BUILD YOUR OWN BELL & HOWELL SOLID-STATE 25-INCH DIAGONAL COLOR TV!**

**It's an enjoyable way to learn new skills that could launch you on a brand-new career in electronics!**

**For free information, mail postage-free card today!**



# A complete at-home learning program in home entertainment electronics!

Send for free information now about this complete, learn-at-home program. Our Bell & Howell Schools representative is ready to bring you all the facts you need.

## Work on this exciting "hands on" project integrated into your learn-at-home program!

As part of your program, you build yourself a Bell & Howell solid-state color television set. This important project gives you "hands on" experience with solid-state circuitry—the kind of *practical* experience you'll need to build a successful career.

## Attend special "help sessions" . . . talk to your instructors in person!

If you'd like some personal advice at any point in your program, you can arrange to attend a special "help session" and talk over special problems with a qualified Bell & Howell Schools instructor.

## Master the most up-to-date solid-state circuitry

As color TV moves more and more in the direction of *total* solid-state circuitry, you'll be thoroughly familiar with the most advanced "trouble-shooting" techniques for these sophisticated circuits.

## Fix stereo systems . . . FM-AM radios . . . phonographs . . . tape recorders

The thorough knowledge of electronics you gain from completing this course and building your own color TV set will be enough to service almost *any* type of home entertainment electronic device—even some that aren't on the market yet!

## Earn extra part time income—or start a business of your own!

The skills you acquire through this unique program can help you earn extra money—or start a business of your own in color TV servicing. We've helped many people start new careers or businesses of their own in electronics.

## Exclusive Electro-Lab® electronics training system—yours to keep!

To make sure you get practical experience with instruments used daily by professionals, we've integrated into your program three precision instruments you assemble yourself: a Design Console, an Oscilloscope and a Transistorized Meter. (See details at right.)

## For Free Information, Mail Card Today!

"Electro-Lab" is a registered trademark of the Bell & Howell Company.



5-inch picture (measured diagonally)

Detach postage-paid reply card and mail today for free information about . . .

### ■ Bell & Howell Solid-State 25-inch Diagonal Color TV:

Ultra-rectangular tube • 25-inch picture measured diagonally • full 315 sq. inch viewing area • solid-state modular circuitry • 4 advanced IC's • 100 transistors • 72 diodes • individual plug-in circuit boards • special UHF/VHF tuning features • built-in self-service components.

■ **Design Console:** "Breadboard" circuits without soldering for both solid-state and vacuum tube experiments • patented modular connectors • transistorized dual-range regulated DC power supply • 12.6 volt center tapped AC power supply • sine and square wave signal generator • test speaker.

■ **Oscilloscope:** Professional technician's diagnostic instrument • 5-inch screen • wide-band • sharp screen images • calibrated for peak-to-peak voltage and time measurements • 3-way jacks for leads, plugs, wires.

■ **Transistorized Voltmeter:** Measures current, voltage, resistance on large dial • combines vacuum-tube voltmeter with multimeter • sensitive, 4-inch, jewel-bearing d'Arsonval movement.

**NEW** . . . with your first lesson, you get the brand-new Laboratory Starter Kit: A volt-ohm meter (VOM) with design panels • modular connectors • experimental parts • battery power source. Gives you *immediate* "hands on" experience with your very first lesson.

If card has been removed, write:  
An Electronics Home Study School  
DEVRY INSTITUTE OF TECHNOLOGY

ONE OF THE  
**BELL & HOWELL SCHOOLS**  
4141 Belmont, Chicago, Illinois 60641

523

# Put that Clock



By F. J. Bauer W6FPO

When the clock radio blows, it is hardly worth your while trying to find out why the radio chassis quit. Unless the trouble is something obvious like a bad electrolytic capacitor or output transistor, why not replace the AM radio chassis with a new one? If you have a portable transistor radio with a broken case or a bad speaker, you can use it as a replacement chassis by making a simple change in the clock radio power supply. If you have no spare transistor radio, you could install a code practice

oscillator in place of the radio. It will not awaken you to music, but it will wake you up with the tone of your choice.

**Radio-Fix-It.** If you decide to replace the AM radio chassis with working unit, it is a good idea to retain the tuning capacitor and audio gain control of the original clock radio. The original knobs may then be used without the bother of having to mate them to replacement control shafts. The only catch is that the tuning capacitor of both receivers should be electrically identical for proper tuning.

Simply remove the mounting plate with the controls on it from the defunct chassis and wire the assembly to the replacement chassis after removing the old tuning capacitor and gain control. The additional lead lengths make no difference in the performance of the replacement set. Also, the modification will not affect tuning dial settings noticeably, since these receivers have only an approximate tuning scale. However, play it smart, keep the leads reasonably short. This completes the mechanical job of adapting the replacement AM chassis to the cabinet.

Many clock radio chassis run on a 15-VDC supply instead of the usual 9 VDC for portables. If your replacement chassis is designed for 9 VDC, you may still use the

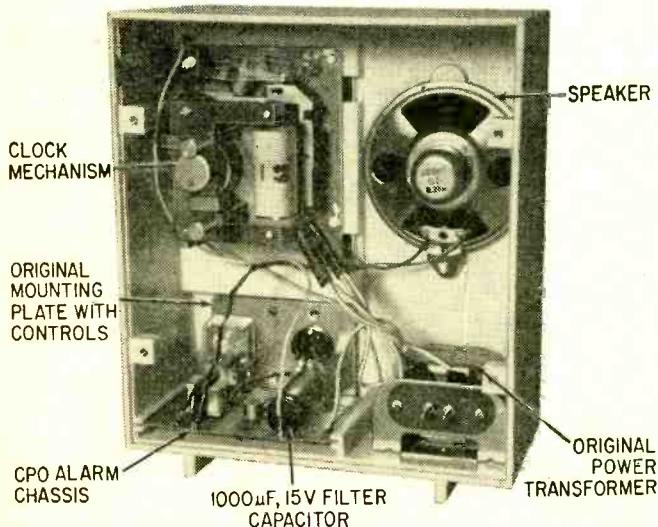

Here's a great way to salvage a good clock that caught radio failure! The Rx includes either a new transistor radio chassis or your own home-built one-transistor tone generator. Either way, your sack-time terminator doesn't sound quite as harsh when you revamp it yourself. Or does it?



# Radio Back on the Job...

original power transformer in the clock radio, but it will be necessary to add a dropping resistor in the DC filter circuit of the power supply. See the *Power Supply* schematic diagram. Experiment with the value of the series dropping resistor, R1, until the voltage to the chassis is about 9 VDC. Start with, say, 1000 ohms and *gradually decrease* the resistance value until the proper voltage is obtained with the AM radio volume set at minimum. A convenient way to do this is to use a potentiometer. There is no danger of damaging the potentiometer since the power dissipated is only a fraction of a watt. Remove the potentiometer from the circuit and replace it with a one-watt fixed resistor that closely approximates the potentiometer setting. Insert the fixed resistor into the circuit and recheck the voltage.

Now check the performance of the receiver at normal volume. The power supply voltage will drop on volume peaks, but not enough to cause serious distortion.

**Add A Tone.** If you have no suitable AM chassis available as a replacement, why not install a code practice oscillator instead? Its

dulcet tone will awaken you just as readily as any local radio station would. A suggested circuit for the CPO, using a minimum of parts, is shown in the *CPO* schematic diagram. The oscillator requires 3 volts, or so, for proper operation and a series dropping resistor, R1, in the filter circuit should be selected as described previously to give this output voltage.

The 5000-ohm potentiometer, R2, should be adjusted for a pleasing tone and, if you prefer, replaced with a fixed, 1/2-watt resistor of the nearest standard value. In some cases, it may be necessary to add a capacitor, C2, across the primary of T2 to get the tone you want, since the frequency of oscillation of the oscillator depends to a degree upon the characteristics of the transformer used. Do not use a capacitor larger than .25  $\mu$ F. It may result in unstable oscillation and low output. After the capacitor is permanently installed readjust R2 for a pleasing tone and check the oscillator for prompt starting.

That's all there is to giving the old clock radio a new lease on life. Pleasant dreams! ■

## A BUILD IT FAST PROJECT

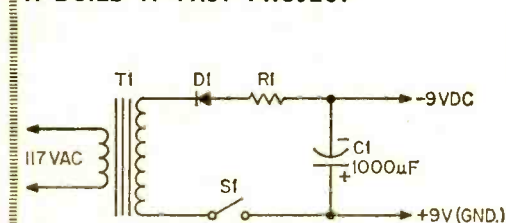

### PARTS LIST FOR POWER SUPPLY

- C1—1000- $\mu$ F 15-VDC electrolytic capacitor. (Use capacitor in clock radio or replace.)
- D1—Diode rectifier, 200 PIV, 1A (Use unit in clock radio or replace.)
- R1—1/2-watt resistor (See text for selecting value)
- S1—SPST switch (Alarm switch in clock movement)
- T1—Power transformer (Use unit in clock radio or replace with 115-VAC primary; 12-VAC, 1.2-A secondary.)

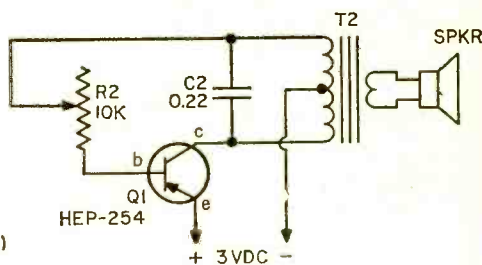

### PARTS LIST FOR CPO

- C2—0.22- $\mu$ F, 100-VDC disc or tubular capacitor.
- Q1—Audio transistor, PNP, 2N427, 2N396, SK3004, HEP-2, HEP-254, etc.
- R2—5000 or 10,000-ohm potentiometer, taper not critical.
- SPKR—Use original unit in clock radio or replace with speaker with same physical dimensions.
- T2—Audio output transformer (Salvage from old transistor radio or Radio Shack 273-1381, or equiv.)

# UHF ACTION BAND... SIGNAL SHIFTER



by Morrie Goldman  
WA9RAQ



**Clever  
nothing-to-build  
technique puts  
UHF action band signals  
on any 30-50 MHz  
low band FM monitor**

**I**F you already own a low band 30-50 MHz Action Band (public service) monitor and would like to tune the UHF public service band as well, here's a simple solution: Just connect the output of a standard UHF TV converter to the antenna input of your low band monitor. Since a UHF television converter must cover a broad frequency range (470-890 MHz) and since its IF output is also broad, it is possible to tune-in UHF Action Band (450-470 MHz) signals on a low band monitor.

**A Little More Detail?** Most TV converters are designed with an IF output on channel 5 or 6; a few use 2 or 3. Whenever the converter is fed into a lower frequency IF, the tuning range of the converter is effectively shifted lower (the dial calibration moves up). While tuning a UHF TV converter connected to a TV set, you may have already noticed the effect. If your converter's IF output is adjusted for channel 6 and you switch to channel 3 or 4, the cali-

bration moves up. There is a limit to this of course, but it is far enough below 450 MHz to make a hook-up like this work the way we want it to.

The connections are simple. We just substitute the low band monitor receiver for the normal TV set connections. With a converter output of channel 5 or 6, tune your monitor to about 49 MHz. If your converter's output is channel 2 or 3, try around 40 MHz. Now tune your UHF converter slowly around channel 17. If there is UHF activity in your area, you should be hearing it.

**Final Hook-Up.** A regular UHF TV antenna should prove suitable in most areas. Of course, an outdoor antenna is preferred. At my home in Chicago, many UHF stations (including police, taxi, radiotelephone, etc.) are "solid copy" using just a low-cost UHF converter, regular UHF TV antenna, and either of my two low band monitors, one of which is an \$18 portable! ■



# A Designer's



# ±15V

## POWER SUPPLY

Read about new standards you build into a simple lab-grade supply

by Herb Friedman

**W**ITH VERY FEW EXCEPTIONS, equipment and projects using operational amplifiers require a bipolar power supply, that is, a power source with both positive and negative voltage outputs in relation to ground. While it is generally possible to power an opamp from a single-ended power source, this technique requires a lot of extra hardware and filtering, and more often than not causes more problems than it's worth. The best way to power an opamp or a project using an opamp is with a dual tracking bipolar supply. Now, thanks to the latest in IC technology you can build a  $\pm 15V$  dual tracking supply for well under \$20.

**It's Short Proof.** The bipolar supply shown in the photographs puts out up to 100 mA with full overload protection; in the event of a short circuit, the supply automatically

shuts down before it's damaged. The really big plus in operation is *dual tracking*, which requires an explanation. The usual way to obtain a dual voltage output is shown on next page; a center-tapped transformer, bridge rectifier and Zener diode regulators do a fine job in non-critical circuits. This circuit is usually used for audio preamplifiers. However, suppose you power not only an opamp but a relay amplifier connected across half the output; the opamp might pull 10 mA while the relay amp pulls 60 mA from one half the supply. This will usually cause a voltage drop on one half of the supply. If the opamp is in a critical circuit, the voltage unbalance between each side of the supply can cause improper circuit operation. Further, internal power supply heating can change the characteristics of the Zener

# BI-POLAR SUPPLY

diodes, again causing voltage mismatch.

A dual tracking supply, on the other hand, does just what it says, tracking one side against the other. Any voltage change on one side of the circuit automatically corrects the voltage on the other side to match. Heating effects are also compensated for on the opposite side, so that regardless of load current, ambient heat or whatever, the voltages on both sides of the supply track together. In the model shown the worst-case mismatch is 0.15 volts (150 millivolts). If one side is -15.00 volts, the other side can be, worst-case, +15.15 volts.

Two more big pluses for the bipolar supply are voltage regulation and extra, electronic filtering. Within the power line range of 100 to 135 volts, the bipolar supply output will not vary more than 0.004 volt (typical), nor will current output changes from zero to full load (100 mA) cause more than a 0.005 volt typical variation. There is better than 120 dB filtering, with the ripple components less than 20  $\mu$ V.

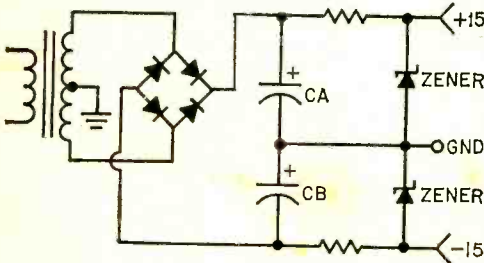

**Simple Zener-regulated shunt-type supply lacks regulation, tracking ability and stability necessary for precision use.**

**Smaller Caps.** In short, this is an ideal supply for the lab and experimenter as it eliminates any worry about the power supply; you can spend your time checking and developing the circuit rather than fussing with power supply regulation and filtering. Actually, the circuit is not much more expensive than a cheap diode-type supply because it doesn't require brute-force filter capacitors which often cost more than an integrated circuit regulator.

The heart of the bipolar supply is IC1, a complete integrated regulator that replaces 21 transistors, 7 Zener diodes and 11 resistors. Until this IC was made available a dual tracking bipolar supply took all these

parts. In addition to regulation, IC1 also features current limiting; just two  $\frac{1}{2}$  watt resistors protect IC1 against damage if the output current attempts to exceed 100 mA. Though the worst-case regulation is specified as 1 percent, in actual tests on complete supplies the regulation was better than 0.5 percent.

**Construction.** The entire power supply is built on a 2 $\frac{3}{8}$ -in. x 4-in. printed circuit board which can be mounted inside any cabinet along with the equipment it is powering. Alternately, it can be installed in a small cabinet as shown for use as a bench or test supply. The cabinet shown in the photographs is a DeLuxe Metal Utility Cabinet from Radio Shack priced well under \$3.

If you use the template available in the parts list to lay out your PC board, we suggest you use the Radio Shack parts specified in the parts list since lead spacing matches the printed circuit board component mounting holes. No components other than IC1, however, are critical and substitutions can be made.

First step is to prepare a printed circuit board. Cut a section of copper-clad board—any type, to size and scrub the copper clean with steel wool or a strong household cleanser such as Comet. Place a piece of carbon paper, carbon side towards the copper, on the board and tape the board under the full-scale template provided and secure the board in position with a few strips of Scotch or masking tape.

Using a sharp pointed tool such as a scribe, indent the copper at each mounting hole by pressing the point of the tool firmly through the template and into the foil. The

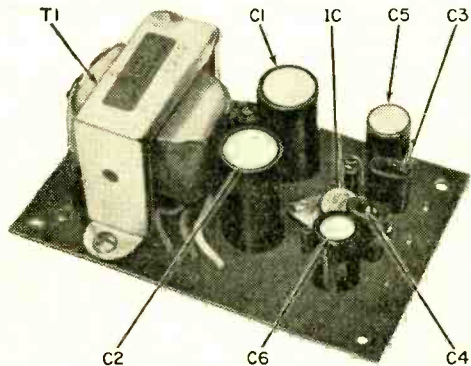

**The printed circuit board template is available free. Check details at the end of the parts list on the opposite page.**



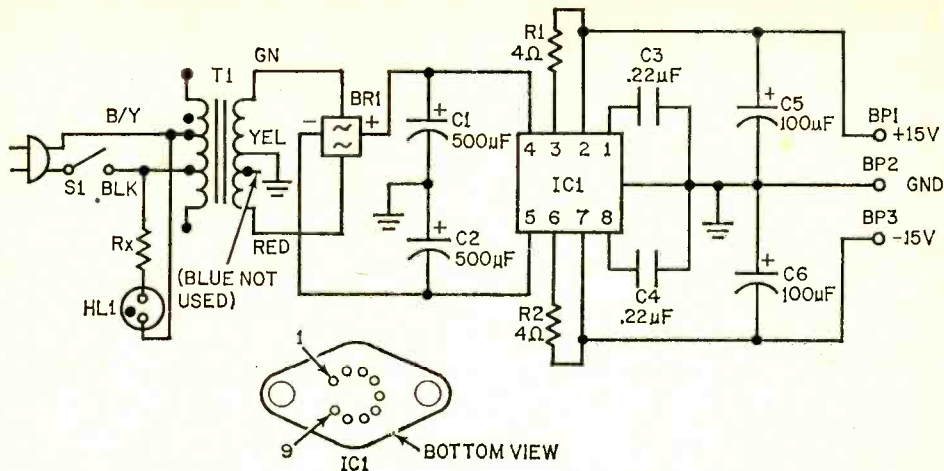

### PARTS LIST FOR $\pm 15\text{V}$ BIPOLAR POWER SUPPLY

- BP1, BP3—Insulated binding post (any style)  
 BP2—Grounding binding post (any style)  
 BR1—Bridge rectifier, 100 PIV, 500 mA or better  
 C1, C2—500  $\mu\text{F}$  electrolytic capacitor, 35 VDC or better  
 C3, C4—0.22  $\mu\text{F}$  mylar capacitor, 50 VDC or better  
 C5, C6—100  $\mu\text{F}$  electrolytic capacitor, 35 VDC or better  
 IC1—Integrated circuit regulator, Motorola 1568R  
 L1—Neon pilot lamp assembly with internal re-

- idents will provide the markings for the component mounting holes. Using a ball point pen and a lot of pressure, trace the foil outlines on the template. Remove the copper-clad board from under the template and using a resist ink pen trace the foil outline on the board; then fill in the areas with resist. No foil should be less than 1/16-in. thick as undercutting by the etchant will produce a slightly thinner foil.
- Pour enough etchant into a container slightly larger than the PC board so there's at least 1/4-in. depth. Then float the PC board on top of the etchant with the copper side down into the etchant. Every few minutes agitate the etchant container to speed up removal of the undesired copper. After all the undesired copper has been removed (about 20 minutes) rinse the board under running water and remove the resist with a small rag soaked with resist remover, resist solvent or acetone.
- Holes And Such.** All component mounting holes are drilled with a #55, 56 or 57 bit. The board's corner mounting holes should clear a #4 screw; the transformer's and IC1's

- sistor (Radio Shack 272-328 or equiv)  
 R1, R4—4 or 5 ohms, see text  
 Rx—Part of NLI assembly  
 T1—Low voltage rectifier transformer (Allied Electronics, No. 705-0127, 401 E. 8th Street, Fort Worth TX 76102)
- Misc.—Printed circuit materials, cabinet, wire, solder, etc.  
 For a free full-size drawing of the circuit board used in the project, send a Self Addressed Stamped Envelope to Electronics Hobbyist, Template Offer, 229 Park Avenue South, New York, NY 10003.

mounting holes should clear a #6 screw. Do not make the holes larger than needed.

Install bridge rectifier BR1 first, using extra care in orientation. The usual terminal arrangement of the low cost "surplus" bridges available to the experimenter usually have a similar lead arrangement. Note that one terminal is marked +, indicating the positive DC output. Two other terminals are generally marked with a "—" (sine wave) or the letters AC indicating the connections from the power transformer. The fourth lead, the one diagonally opposite from the + lead, is the negative DC output. Make certain your bridge rectifier has this terminal arrangement. If it has any other lead arrangement you must modify the PC board template (if you use it) to correspond to the difference. Install BR1 so that when the leads pass through the board to the foil side the + lead comes through the "plus" hole.

Allow about 1/4-in. space between the bottom of BR1 and the PC board and solder the leads to the foil. Then install and solder IC1. IC1 can fit the board both right and wrong. Make certain the space between the

bottom of BR1 and the PC board and solder the leads to the foil. Then install and solder IC1. IC1 can fit the board both right and wrong. Make certain the space between the

bottom of BR1 and the PC board and solder the leads to the foil. Then install and solder IC1. IC1 can fit the board both right and wrong. Make certain the space between the

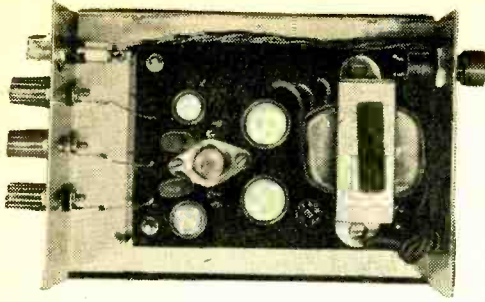

**Birds eye view of the 15 V bi-polar power supply for professional-type applications.**

pins faces the nearest edge of the PC board, then secure IC1 with two short #6 screws. Install power transformer T1 and all other components. T1 has several unused leads, simply cut them off at the transformer with diagonal cutters.

Current limiting resistors R1 and R2 should be 4 ohms, a somewhat expensive and difficult value to obtain. You can substitute two parallel 10 ohm, 10 percent, 1/2-watt resistors (Radio Shack series 271-000); the board already has the extra mounting holes for two resistors at R1 and two resistors at R2. The difference between the required 4 ohms and the resultant 5 ohms from the parallel resistors will have no appreciable affect on the power supply operation.

To make a bench supply, the PC assembly can be installed in a metal cabinet as shown. The three output terminals are 5-way binding posts. Two outside posts, used for the + and - voltage outputs, are insulated from the cabinet. The center terminal, the com-

mon ground, is connected to the cabinet by its own mounting nut (do not place an insulator under the nut).

Power switch S1 mounts on the rear apron and can be any type of SPST switch. To prevent the foil on the underside of the PC board from shorting to the cabinet use a 1/4-in. metal spacer or stack of washers between the board and cabinet at each mounting hole. If desired, a neon pilot lamp can be installed. Make certain the pilot lamp is the type with a built in current limiting resistors of 56,000 to 200,000 ohms.

**Service Note.** If the power supply fails to operate properly, if, for example, there is voltage on one side but not on the other, or if both voltages are extremely low, it is most likely that the polarity of C1, C2, C5 or C6 is reversed. Take extra care to check that C2 and C6 have their *positive* terminal connected to ground. If you use the Radio Shack capacitors specified in the parts list, all polarities are correct when the vertical arrow on each capacitor faces the same direction. But don't take chances. The capacitors you get might have the arrow misprinted or used to denote another polarity. Doublecheck that the polarity is correct.

If the capacitor polarities are correct and the output voltage is nearly correct but tends to wander, if the output voltage can't settle down to a rock steady value when current is drawn, it is most likely that you have used the wrong primary connections on T1. The proper wires are color-coded. Use a secondary output voltage of 40 volts rms center-tapped (20-0-20). ■

## Load Matcher

□ Most audio circuits transfer their maximum power at minimum distortion only when the output impedance is matched to the load impedance. But it is often necessary to connect equipment of differing impedances. For example, how do you correct an amplifier with a 600 ohm output into an amplifier with a 50 ohm input? Usually, if the 50 ohm input is connected across the amplifier with a 600 ohm output, the excessive loading caused by 50 ohms will sharply reduce the output of the 600 ohm amplifier, and will generally increase the distortion sharply.

A minimum loss pad is the device used to match a high impedance to a low impedance. Though there is always a signal

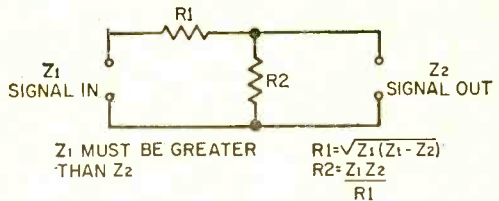

level loss through a pad, the circuit shown provides the absolute minimum loss that can be obtained while providing a precise match. If the resistance values work out to odd values, such as 134 ohms, use the closest standard value. Though 5 percent tolerance resistors are suggested, almost as good performance will be obtained with 10 percent resistors. ■



# Build CAP RAPPER

by Herb Friedman

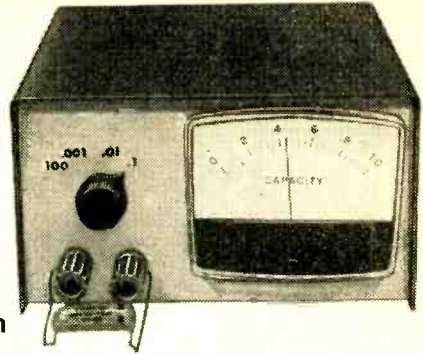

**W**ITHOUT DOUBT a direct reading capacity meter is the fastest and probably the most reliable way to check and sort small capacitor values. Simply place the unknown value capacitor across the instrument's test terminals and a meter directly indicates the correct value with no potentiometers to balance or false *magic eye* indications to confuse things.

Direct-reading capacity meters were once strictly a laboratory item. Now, using modern solid state devices, you can build a high-accuracy model for your own shop for less than \$20—money you'll get back many times over by sorting out those *50 capacitors for a \$1* in a matter of minutes, rather than hours.

Also, because the direct reading capacity meter is so easy to use, you'll no longer get hung up on capacitors which are nowhere near their indicated values. For example, small disc capacitors can easily be 20, 50 and sometimes 100 percent off their indicated value. Now imagine the next oscillator you build that calls for a 20 pF capacitor; after hours of troubleshooting you find it doesn't work because the capacitor is really 50 pF! With a direct reading capacity meter you can, in seconds check each and every capacitor value before it's installed in your project.

The Direct Reading Capacity Meter shown in the photographs checks capacity from 4 pF to 0.1  $\mu$ F in four switch selected ranges. The test voltage applied to the "unknown" capacitor is a square waveform 15 V peak-to-peak maximum, so it's safe for just about all capacitors generally used, and it presents no shock hazard to the user. The overall accuracy is just about 5 percent, allowing for the tolerance of the meter movement itself and the capacitors you use for alignment. In actual practice the overall accuracy can work out to about 3 percent.

**How It Works.** Integrated Circuit 1 is a

multivibrator producing square waves which are applied to the unknown capacitor connected across binding posts BP1 and BP2. The current that is allowed to pass through the capacitor is measured by meter M1, whose scale is linear (no tricky calibration needed). Since the capacitor's reactance determines the current flow, the meter indication is in direct proportion to the total capacity.

Meter calibration is obtained by varying the multivibrator output frequency from approximately 20 to 20 kHz. (The DC voltage applied to the unknown capacitor is essentially 100 mV worst-case, so you don't have to worry about DC voltage ratings.)

Though meter movement M1 is 50  $\mu$ A, a simple-to-make 0 to 1 scale simplifies measurements. Three ranges are indicated as .001, .01 and .1, representing full-scale values. If range switch S1 is set to .01 and the meter indicates .6 the "unknown" capacitor value is .01 x .6 or .006  $\mu$ F. If the range switch is set to .001 and the meter

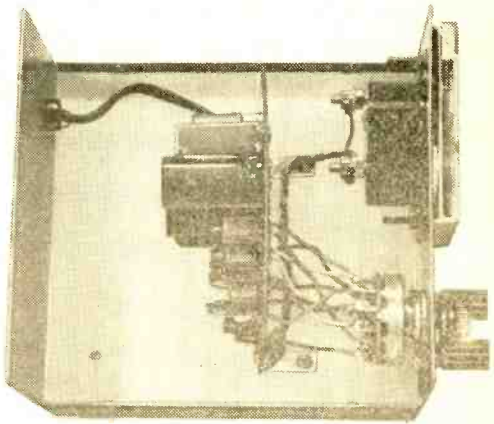

This technical teething ring tells you instantly the value of an unmarked capacitor. All but front panel parts are on a PC board.

# CAP RAPPER

indicates .2, the unknown capacitor is .001 x .2 or .0002  $\mu$ F.

The fourth range switch position is marked 100, meaning 100 pF full scale. This has been done to avoid answers with four or more decimal places and because small-value capacitors are generally marked directly in pF, such as 10 pF, or 68 pF. To obtain the correct value for small capacitors multiply the meter reading by 100 pF. For example, if the meter reads .4 the capacitor value is .4 x 100 pF or 40 pF. In actual practice you won't have to bother

instrument capacity can rise well above 10 pF.

The most critical part of the meter is the square-wave generator, so use a PC board as specified; do not substitute point-to-point wiring. There are no stability or accuracy problems if you use the PC layout template.

Note that even though IC1 is the round TO-55 type, we have used a socket. While the socket is not critical, the entire assembly is a lot easier if the socket is used, and it also avoids soldering-heat damage to the IC. IC1's socket is a 14 pin type with only eight terminals used for IC1. Before starting any assembly, fan-out IC1's leads so they match the socket. Using only finger pressure—no tools—fan out IC1 number 1

Use the exact size template found later in article to make your PC board. This somewhat oversized view shows component (top) side of board and X-ray view of copper area.

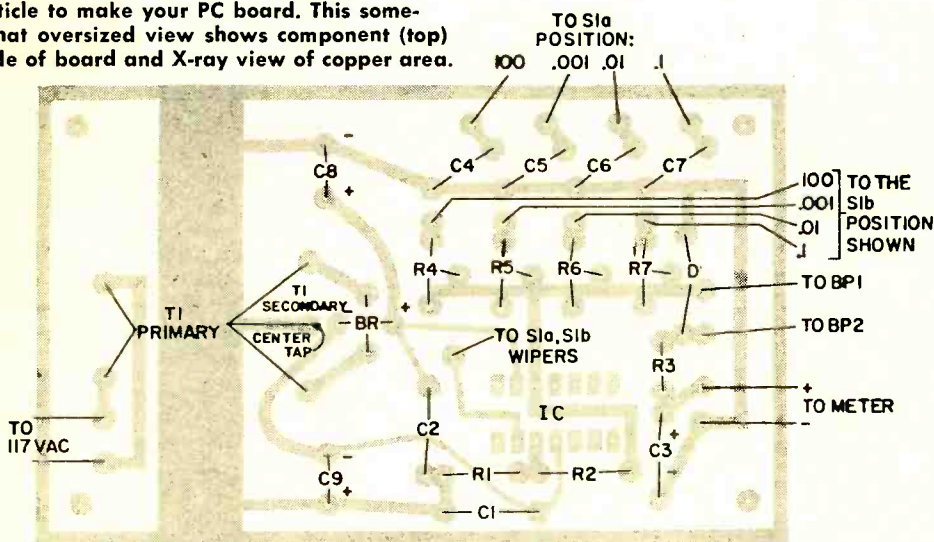

with the calculations as the meter reading will suffice—you'll know that a .4 reading on the 100-scale is 40 pF. The same applies to the other ranges. This procedure is a lot simpler than cluttering up the meter scale with four sets of numbers.

**Putting It All Together.** This is one project in which neatness will work against you, so assemble the capacity meter exactly as described; do not try for square-corner wiring, that's fine for military equipment but not the capacity meter. Where short, direct wires are specified, make them short and direct even if it all starts to resemble a rat's nest. With the assembly procedure specified and shown in the photographs, the meter can read capacitor values below 10 pF; if you get too neat with the wiring between the PC board and range switch, the inherent

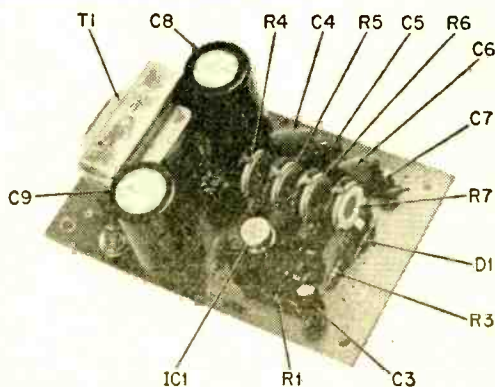

Most parts are called out in this photo. Also, check the front cover for another (in color) look at the printed circuit board.

through number 4 leads so they are in-line to one side. Similarly, fan-out the number 5 through number 8 leads so they are in-line on the opposite side. Take careful note that the lead opposite the tab on IC1's case is the number 8 lead—check with the small diagram next to the schematic. Using diagonal cutters, cut *each* group of leads approximately 3/4-in. below IC1's case. You should end up with two sets of leads cut straight across. Using finger pressure, line up each set of leads so they exactly match the socket connections, then insert IC1 into the socket to *open* the socket connections. Remove IC1 and set it

aside until all other assembly is completed.

We suggest you use a Radio Shack IC socket as it is imprinted with a white color dot on one end; you can use this dot to correspond with IC1's tab. When you install the socket on the PC board, the white color dot should face power transformer T1.

**Make The Board.** To make the PC board, first cut a piece of any type of copper-clad board to 2 3/8-in. x 3 7/8-in. and scrub the board clean with steel wool or a strong household cleanser such as Ajax or Comet; rinse thoroughly and dry. Place a piece of carbon paper on the foil (carbon side against the foil)—and tape the PC board

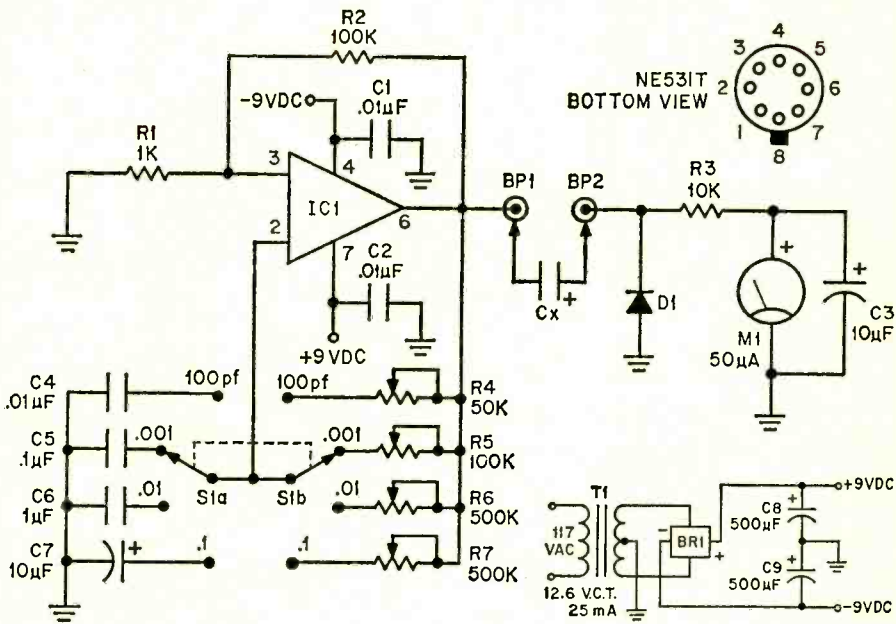

**PARTS LIST FOR THE CAP RAPPER**

- BP1, BP2—Insulated binding post (any style)
- BR1—Bridge rectifier, 25 PIV, 100 mA or better
- C1,C2,C4—0.01 µF capacitor, 25 VDC or better
- C3—10 µF electrolytic capacitor, 6 VDC or better
- C5—0.1 µF capacitor, 25 VDC or better
- C6—1.0 µF capacitor, 25 VDC or better
- C7—10 µF electrolytic or mylar capacitor (see text)
- C8,C9—470 or 500 µF electrolytic capacitor, 35 VDC or better
- D1—Diode, silicon, 1N456A
- IC1—Integrated Circuit, Signetics NE531T (Available from Circuit Specialists Co., Box 3047, Scottsdale AZ 85257)
- M1—Meter, 50 µA (Radio Shack 22-017 or

- equiv.)
- R1—1000-ohm, 1/4-watt resistor
- R2—100,000-ohm, 1/4-watt resistor
- R3—10,000-ohm, 1/4-watt resistor
- R4—50,000-ohm trimmer potentiometer
- R5—100,000-ohm trimmer potentiometer
- R6,R7—500,000-ohm trimmer potentiometer (Radio Shack 271-221 or equiv.)
- S1—Rotary switch, 2-section, 4-circuit (DP4T, see text)
- T1—Low voltage transformer, 12.6V C.T., 120 mA
- Misc.—Wire, solder, cabinet 5 1/4-in. x 3-in. x 5 7/8-in. (Radio Shack 270-253 or equiv.), etching solution, PC board material, etc.



# CAP RAPPER

under the full-scale template provided. Indent the copper foil at each component mounting hole by pressing a sharp pointed tool, such as a scribe or an ice pick, through the template at each hole. Then, using a ball point pen, trace the foil outlines. Remove the copper-clad board from the carbon paper and, using a resist-ink pen, fill in all the foil areas to be protected.

Fill a container with approximately ¼-in. of etchant and float the PC board on top with the foil side down (foil against the etchant). Every few minutes agitate the etchant container to insure a continuous flow of fresh etchant under the foil. After all the excess copper has been etched away—in about 20 minutes—rinse the board under running water and strip off the resist with steel wool or resist solvent (all PC supplies are available from Radio Shack).

Using the indents in the foil as guides, drill all holes with a number 58, 59 or 60 bit. Then enlarge the T1 mounting holes and the corner mounting holes to clear a number 4 or 6 screw. The two holes near T1 used for the line cord should be enlarged with a number 50 bit.

**Install The Parts.** Install all PC board components starting with the IC socket. Take particular care when soldering the socket leads that you don't get a solder bridge across two leads. Transformer T1 is a miniature 12.6 V center-tapped unit at 120 mA. You can use a transformer rated as low as 25 mA. A transformer larger than 120 mA will not fit on the board.

Take care when mounting bridge rectifier BR1. Note the diamond lead pattern shown in the diagram. If the bridge rectifier you obtain has a different lead configuration, you will have to modify the PC board's foil layout accordingly. Leave approximately ¼-in. space between the bridge rectifier and the PC board. Make certain filter capacitors C8 and C9 are installed with the polarity correct. The arrow indicating the negative terminal should face the same way on both capacitors. If you use Radio Shack capacitors, the arrows will face the edge of the board where capacitors C4 through C7 are mounted.

After the IC socket, T1, BR1, C8 and C9 are installed, mount trimmer controls R4, R5, R6 and R7 on the board. Control R4,

which is 50,000 ohms, is positioned closest to T1; then comes R5 which is 100,000 ohms and R6 and R7 which are each 500,000 ohms. The ends of the trimmer leads have a small bend at the tip; installation on the board will be much easier if you squash the tips flat with long nose pliers.

Next, install all the resistors, C1 and C2, C3, and diode D1. Bend the D1 leads so the diode body does not touch the R7 wiper terminal. Finally, install capacitors C4 through C7. The mounting holes for C4 through C7 match miniature components; that is, the printed circuit type with both leads out the same end. Any voltage rating from 25 VDC and up can be used. Though capacitor C7 is specified as a tantalum type, the circuit will usually work with an ordinary electrolytic. The tantalum simply insures long-term stability and is not much more expensive than an ordinary electrolytic. Take note that tantalum capacitors generally have the *positive* (not negative) lead marked with a color dot.

**Panel Components.** Meter M1 is 50  $\mu$ A Calectro, chosen to fit the cabinet. Any 50  $\mu$ A meter can be substituted. Using the edge of a knife with care, snap off the plastic cover (the front of the meter) and remove two screws holding the scale in place. Carefully, so as not to bend the pointer, slide the scale out from under the pointer. Using the same dimensions from the 0 to 50 marks, prepare an 0 to 1 scale and cement it to the original scale. Slide your new scale under the pointer, re-install the two screws and snap the plastic cover back in place.

Install M1, two insulated binding posts (BP1 and BP2) and range switch S1 on the panel. S1 can be anything that has two circuits and 4-positions—whatever you can get at low cost. For example, the unit shown uses a surplus three-circuit 4-position switch, the extra terminals aren't used. No power switch is used because the unit is plugged in when it's needed. If you want a power switch place it on the rear apron next to the line cord.

**Final Assembly.** Install the PC assembly as shown; it is positioned about 1½-in. behind the back of the meter case. The connections to C4 through C7 should be at the top, and the PC board foil should face S1. Note that a metal chassis mount is secured under one of the T1 mounting screws, providing a ground connection to the cabinet. If you use a different mounting for the PC

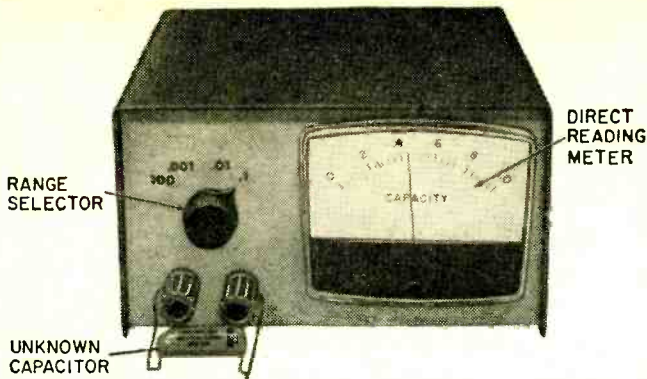

Be sure you understand the operating principles of this direct reading capacity meter. Any capacitor whose value is greater than the range to which you have the unit switched will peg the meter offscale. Simply lower the range switch until the pointer moves back down.

board, make certain you have a connection between the cabinet and the PC board ground foil.

Install the PC-board-to-panel wiring in the following order using the shortest, most direct connection. Leave just a smidgen of slack to avoid strain on the wires. Plastic insulated, solid number 20 or 22 wire is suggested. Note that the wires from S1 enter the foil side of the board. Make certain they don't short any components when they pass through to the top of the board. Of course, solder to the foil side of the board.

Since you are measuring capacitance (C) with this circuit, it's a good idea to duplicate this template exactly to hold down stray C.

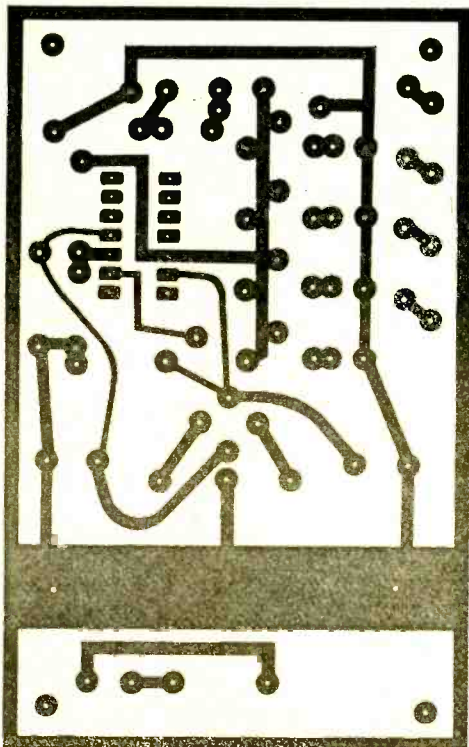

Install a wire from the R4 "hole" to S1; then R5, R6 and R7. Install a wire from C4 to S1, then C5, C6 and C7. The wires from the capacitor connections will probably cross, so just separate them about 1/8-in. Install wires from BP1 and BP2, keeping them at least 1/4-in. apart. These wires should not touch any other wire or component.

Twist together about 8 inches of red and black wire (positive and negative). Connect the black wire to the negative output PC board terminal—the one closest to the bottom of the cabinet. Connect the red wire to the positive output (directly above the black wire). Route the wires along the bottom of the cabinet, spaced about 1/2-in. from the PC board, to the meter. Connect the red wire to the positive (+) meter terminal, and the black wire to the remaining terminal. Then install the linecord.

Finally, install IC1 in its socket. The tab should point towards or be directly above the white color dot on the socket. Rotate each trimmer control towards the IC.

**On The Mark.** Maximum accuracy is assured if the calibration capacitors represent, as close as possible, half-scale; for example, if calibrating the 100 pF range, use a 50 pF capacitor. The voltage across the binding posts is negligible and you can change capacitors with the power on.

The calibration capacitors can be 5% or 1% silver mica, or anything else with a 5% worst-case tolerance. Don't use ordinary capacitors as they can be 50% off value and still be within their tolerance. Each range calibration is independent of the others, what you do to one range does not affect any other adjustment.

Note that when the calibration capacitors are first installed, meter M1 will "pin", this is normal. If the meter indicates a very low

(Continued on page 119)



# Getting Eight-Track Players

## on the Level



by Homer L. Davidson

□ Does music bust in where it is not wanted on your auto eight-track stereo tape unit? In other words—two music channels are being heard at the same time. Man, that's crosstalk! With a simple Auto Stereo Head Leveler, which we tell you how to build, you can quickly touch up those critical playback adjustments and eliminate crosstalk or co-channel distortion. Not only will the Leveler stamp out crosstalk, but it can serve as a balance meter, and it can give some indication of frequency response. It's cheap at half the price—actually less than a buck, or you may now have the parts in your junk box at no cost at all. Just clip the leads of the Leveler to the stereo output speaker leads and you're in business. But, read on 'cause we're going too fast.

**How It Works.** Most car-stereo, 8-track, tape decks have a speaker and power output plug at the rear of the unit. The Stereo Head Leveler can be attached on these connec-

tions or at the speakers themselves. Clip the Leveler to each speaker and common ground lead. Leave the speakers connected with the Leveler in the circuit and hear the music, or tone, as you make the head adjustments.

When rotating the volume control on the tape deck, the pilot light will illuminate proportionally to the music, or sound level, taken from the tape. The light is brightest with the balance control at its center position, indicating correct balance. Height and azimuth adjustments can be made on a regular music tape, but accurate adjustments are made with a cartridge test tape. Since the channels of music are very close together, only a slight adjustment of the height screw on the head assembly is needed to correct crosstalk conditions. Generally, the height screw may be off a smiggen—so go very easy.

**Construction.** A 47 pilot light, two 7.5-



A whole host of tests and checks can come from a handfull of junk box parts. Pep up any 8-track auto tape player with hints and techniques revealed in this article. Turn the page for an inside view of this simple but handy tester.



ohm, 5-watt wirewound resistors and three alligator clips are the only parts used. The light and two resistors are mounted inside a small plastic box. Drill and prepare the mounting holes before placing the parts inside the plastic box. Heat the tip of an ice pick or sharp metal point with a soldering iron to make holes in the plastic. Holes are made in each end and top of box for flexible test leads.

Twist one end of each wirewound resistor together and bend the remaining ends so the resistors will fit snugly inside the plastic box. Form a loop in the remaining end in front of each hole so flexible test leads can be soldered and will not pull out through the hole. Bolt the pilot light socket in place and solder a wire to the metal socket shell. Connect one end of both resistors to this point. Insert a flexible lead through the top hole, tie a knot and solder to the remaining pilot light socket. Recheck the wiring and the Leveler is ready for use!

**Hookup Procedure.** Clip the Stereo Balance Leveler to the speaker leads of the stereo 8-track tape deck speaker leads. Now locate the height and azimuth adjustments near the tape head. Generally, the height adjustment screw is located right behind the tape head assembly and the azimuth screw is off to the side of the tape head. These two adjustments can be made on most tape units by removing a plate located on top of the outer case and adjusting inside with a screwdriver. Some units have manual and screwdriver adjustments at the bottom side of tape player. In most cases, the tape player will have to be dropped down from the dashboard to get at the top adjustments. It may be wise to remove the unit and take it to the test bench. The height screw selects the correct channels and eliminates crosstalk conditions. Adjustment of the azimuth screw levels the tape head on the playing tape for good frequency response. Both of these adjustments are made for maximum brightness of the pilot light.

Before making adjustments set the volume control so the pilot light with Leveler just begins to glow. Turn the bass, treble and balance control to the center position. When the balance control is at center balance position, the pilot light will be brightest. Manually trigger each channel through several times to see if the channel program selector is functioning properly. If not, a good clean-up of gear, pivot arm and solenoid will produce clean program change over. Use a

swab of cotton dipped in alcohol. Also, it's possible to have foreign material such as gum wrappers and excessive oxide dust preventing automatic or manual switch function. Now, before attempting any adjustments, determine if crosstalk is noted on all channels. If crosstalk is noted on just one channel, a slight touch-up of that channel may cure the problem. Recheck each and every channel for crosstalk conditions.

**Adjustments.** Start adjustment at top or bottom channels of the stereo tape player. If adjustments are to be made with a regular stereo cartridge, select one with constant or continuous music. A good stereo cartridge test tape is inexpensive and can save you money in the long run. Recheck the balance control and position where the pilot light is brightest. It is possible one of the channels may be weak, throwing the balance control off to the side. In case the balance control is way off, repair the defective stage before attempting to make head adjustments. Sometimes when using a regular stereo cartridge one of the speaker channels may be recorded a little lower resulting in the balance control off to one side. An audio, 8-track, test cartridge will produce accurate speaker balance and separation.

When making these adjustments always keep the tape player in upright position. If laid on its side or upside down, the tape head assembly may not be in the correct position resulting in improper and repeated adjustments. Remember, the height adjustment may be off  $\frac{1}{16}$  inch of a turn and requires just a touch-up. Make the height adjustment with the tape playing back about 1000 Hz. Any band of frequencies from 750 to 5000 Hz can be used. Some audio test tapes have a 7500 Hz azimuth or tilt test signal for azimuth adjustments. This test is for proper angular positioning of the playback head with relationship to the tape. Make both adjustments for greatest brightness of pilot light in the Leveler.

After making azimuth and height adjustments check for crosstalk on each tape track. Turn the balance control to the far left and listen for crosstalk. Check the right channel in the same manner. Test each track with a recorded cartridge and listen for crosstalk at the end of each recording.

**Other Tests.** Besides tape head alignment you can check the tape player for frequency response, equalization, sweep frequency, intermodulation distortion, channel identifica-

# Eight-Track Players

tion and separation on an audio test cartridge.

A series of tones from 70 to 8000 Hz are used for checking the overall frequency response of the tape player system on frequency response and equalization test. Adjust the volume until the bulb barely glows and leave it. In perfect equalization the brightness of the light should be approximately the same on all frequencies.

A continuous frequency sweep from 8000 down to 70 Hz is used in sweep frequency test. It will clearly indicate any serious peaks or dips your tape players may have. Don't be surprised if the tone varies up and down in the speakers. This sweep frequency test will also indicate any serious resonant peaks in the speaker or mounting location.

Intermodulation distortion tests will show up any "buzz" or indicate trouble in poor

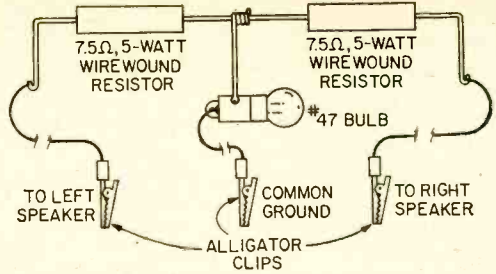

**Use a number 51 lamp for high power installations. Its shape is shown above. The number 47 lamp bulb, shown on the first page, is for average power players.**

circuitry, dirty heads, bad speakers, etc. Now is the time to clean up that dirty tape head.

The channel identification and separation test will identify each channel and check placement of speakers. You can check the gain of each channel by turning the balance control fully to each channel under test. Notice the gain of each channel. All speakers should be connected in making these tests. ■

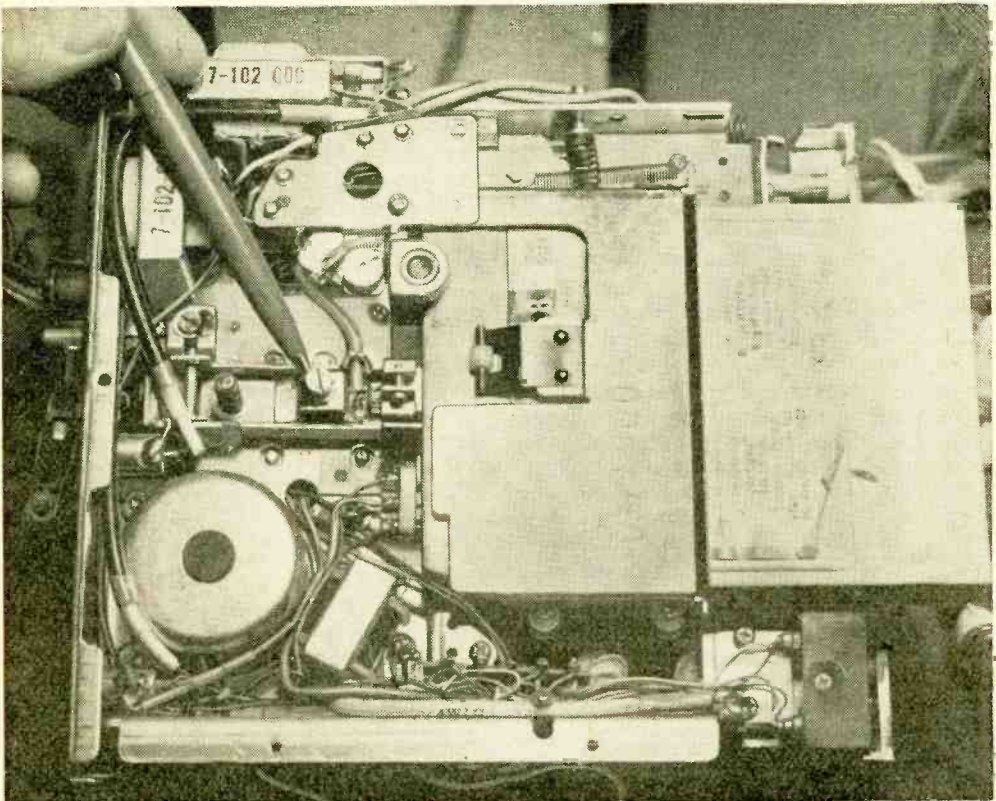

Simply connect the auto-stereo head leveler to the left and right speaker connections. Clip the common wire to common speaker ground. Be sure to locate the height screw shown.



## DOUBLE-DUTY SKYHOOK HELPS...

# FLAG DOWN THAT DX

by Elmer C. Carlson



**I**F the neighborhood vigilantes come to lynch you every time they get a little squiggle in their TV picture, it's time to run up the flag and take down your attention-getting antenna. Don't quit! Just go underground with this flagpole antenna. If you carefully hide your antenna lead, the neighbors will never suspect a thing and go looking for someone else to blame for their TVI.

**Easy To Build.** With our flagpole antenna you put together your own flagpole. Sometimes it's almost impossible to find a ready-made flag pole, but you can put together a flagpole using the simplest of hand tools, a little effort, and low-cost materials available from any well-stocked hardware or building supply store.

For SWLing and BCB DXing the antenna length can be as long as practical. But remember, the flagpole also has to hold the flag on those 8 or 10 flag raisin' holidays in each year. If you don't run up that flag, the neighborhood vigilantees might just get suspicious and come knocking at your door once again!

The length of the flagpole antenna isn't really critical because the "flagpole" can be tuned either electrically or mechanically. For easier construction, break down the project

into four separate tasks: assemble the flagpole, bend the TV-mast brackets, attach the brackets to the house, and the final assembly, erecting the flagpole. Actually, more than half of the work can be done indoors with just the final assembly being done outdoors.

**Flagpole Assembly.** First, the lengths of aluminum pipe or thick-wall tubing must be joined. If the "flagpole" is to be no more than 14½ feet in length, only two sections will have to be joined. For a "flagpole" between 14½ and 21 feet, three lengths must be joined. To reinforce the joint, drive a tight-fitting dowel into the smaller diameter section of the two lengths to be joined. The length of the dowel used should be somewhat longer than the amount of overlap in the two lengths of aluminum pipe. For example, if there is an 18 inch overlap—18 inches of the smaller diameter tube telescoped inside the larger—you should use about 24 inches of dowel.

Next, mark the aluminum pipe to show how much of the smaller diameter pipe should be telescoped into the larger diameter pipe. Put marks on the larger diameter pipe at 4 and 14 inches. Now telescope one pipe into the other and drill a ¼-inch hole (or



# FLAG DOWN THAT DX

use a #35) at least 1/2 inch deep into the pipe at the 4-inch mark. Drive a #8 gimlet-point pan-head sheetmetal screw into the hole. Now drill the second hole, at the 14-inch mark.

It is important to drive that first screw into its pilot hole *before* drilling the second hole as this will make sure that both sets of holes through the sides of the pipes are properly aligned when you drive the screw into that second hole. At this time you can remove that first sheetmetal screw and separate the pipes if it's more convenient for you to store the flagpole temporarily or to carry it out of the workshop.

If three lengths of pipe are to be used, just repeat the procedure for the second joint.

Before you go running outside with the "flagpole" be sure to attach the top ornament or cap (from the flag set) to the end of the top section of the flagpole. And don't forget to attach the small awning pulley to the cap. Once attached, the cap and pulley do not have to be removed.

**Bracket Bending.** If you can mount the TV antenna wall brackets on the side or end of the house, you won't have any bracket bending to worry about. Unfortunately, such installations are rare because they are not usually practical or architecturally suitable for an honest-to-goodness flagpole.

But it's easy to bend the low-priced wall brackets so they will hold the "flagpole" at an angle when one bracket is mounted on the house proper and the other is attached to the eaves of the roof. Even if you don't have a bench vise, it's still not difficult to bend the brackets. Instead of a vise you can use a large adjustable open-end wrench.

After both legs of the bracket are bent, place the bracket on a flat surface to see if the bracket has enough angle to it. (You can put the other half of the dowel into the clamp of the wall bracket to get a better idea of what the angle of the "flagpole" will be.) When you are satisfied with the angle the bent bracket will give the "flagpole," just bend the second bracket to match the angle of the first bracket.

**Attaching The Brackets.** First attach the upper bracket to the eaves of the roof. You can use #14 round-head wood screws, but

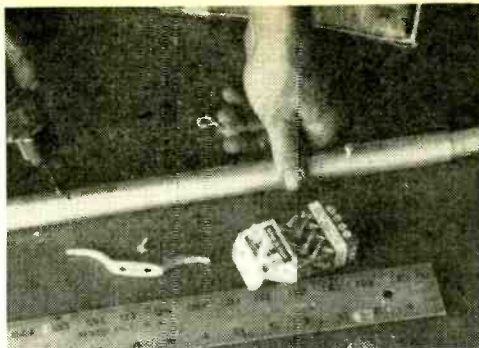

Items used are found in most hardware and building supply stores. Holes through pipe and dowel are shown drawn on the next page.

## Bill of Materials

Flag set (one with a 3 x 5-foot flag)  
8-foot length 3/4-in. o.d. (1/2-in. i.d.) aluminum pipe  
8-foot length 1-in. o.d. (3/4-in. i.d.) aluminum pipe  
3 or 4-foot length 1/2-in. o.d. hardwood dowel  
4-inch TV mast bracket  
25-foot length of venetian-blind cord  
Small awning pulley (one required)  
Small awning cleat (one required)  
Small lanyard clips (two required)  
Miscellaneous. 1/2-in. number 8 gimlet-point pan-head sheetmetal screws, lag screws, flat washers, masonry anchors or toggle bolts



A small lead weight sewn into the bottom corner of the flag will prevent it from becoming wrapped during a windy day.

lag screws are a lot easier to work with on a ladder. The square head on the lag screw makes it easy to tighten with a wrench, while the wood screws need considerable effort and pressure to keep a screwdriver in the slot. Applying enough pressure to a screwdriver while at the top of a ladder isn't easy—or very safe either.

Once the upper bracket is attached to the house, insert the bottom section of the mast into the clamp. Tighten the clamp with your fingers just tight enough to help hold the bottom section of the "flagpole" while you adjust it to match the angle of the bent wall brackets.

Attach the lower bracket to the bottom section of the "flagpole" about 3 inches up from the end. If you don't think your eye is good enough to set the "flagpole" straight

insulate the antenna since roof flashings (those metal edgings) and rain gutters would seem to be useful as conductors for added signal pick up. Sure, they can give you more signal, but sometimes they can give you less. Those additional conductors can add directional effects to your almost vertical flagpole antenna, instead of more signal you'll get less signal from some directions. Be safe. Insulate! Afterwards you can test the effects on the SWL and BCB signals by using short jumpers or clip leads to connect to those handy flashings and gutters. Remember, these additional conductors may improve signal strength on some frequency bands or from some directions while making the reception of signals worse for other frequency bands or directions.

The insulating material you use is not too important. It should not be too soft and it should not readily absorb water. Wide plastic tape or strips of plastic (cut from milk or liquid detergent containers) can be wrapped around the "flagpole" and field in place with tape or cord. The thicker the insulation the better, just don't make it so thick that it won't fit in the clamps of the wall brackets.

**Erecting The Flagpole.** This last step includes the final assembly. Join the lengths of aluminum pipe and then thread the venetian-blind

**Large diameter tube fits into a smaller tube with hardwood dowel for support and added strength.**

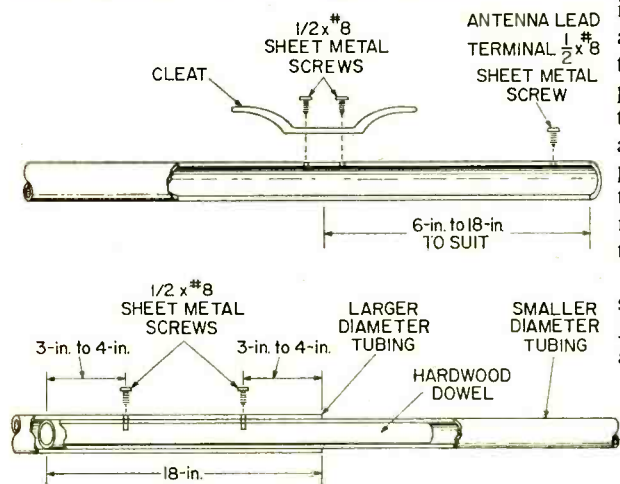

out from the side of the house you'd better use a level. While holding the level against the side of the pipe, mark the location of the holes of the bracket on the wall. Also mark the position of the upper bracket on the mast, and the top and bottom edges of both clamps before you take the mast down. These marks will show where the antenna insulators must go if they are needed. If your wall is a non-conductor, like wooden lap siding or asbestos siding, you may not need insulators if the climate is dry. Attach the lower bracket to the wall of the house. If the wall is brick or concrete you'll need expansion anchors. For a cinder block wall you may need toggle bolts if you drill into one of those open areas of the block. For wooden or asbestos siding you can use lag screws.

**Antenna Insulators.** For SWLing and BCB DXing it may not seem necessary to

cord through the awning pulley. Be sure to unroll the complete length of cord and tie the two ends together to prevent their slipping out of the pulley. Now all you have to do is slip the flagpole into the loosened clamp of the lower bracket and replace the clamp of the upper bracket.

**Finishing Up.** All the hard work is finished—just a few final touches left and then you'll be all through. Drill two more holes to attach the lead-in wire and the cleat (to hold the rope) to the "flagpole" antenna. If you tie down the lead-in wire with nylon fish-line or lacing cord, the lead-in will be almost invisible except for close inspection. Tie a pair of lanyard snaps to the ends of the venetian blind cord to make it easy to attach and remove the flag. Wrap the loose end of the rope around the cleat, connect the other end of the lead-in to your receiver. Tune across the band and see who QSLs. ■



# VIBRA-TONE

Dig it! This pocket vibra-tone has three voices, an eleven note keyboard, real vibrato and uses only three IC's in a real Hep circuit. It builds with new stick-on printed circuit material.

by Darrell Thorpe

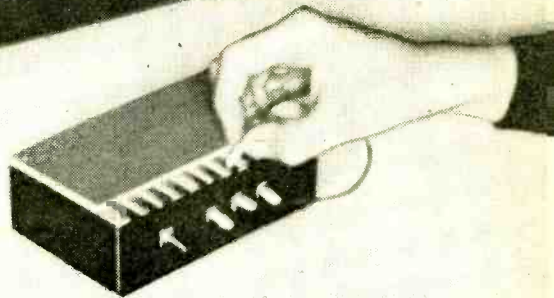

Maybe, to make a hit at a party, to spring a surprise on the boys in the combo, or give the kids a terrific toy, all you need is this pocket Vibra-Tone. Made from three low-cost integrated circuits and only a few other parts, the vibra-tone provides a really excellent little musical instrument—and it includes the sophisticated effects of voicing and vibrato that you would expect to find only in rather expensive musical instruments.

This project is simplified by the use of integrated circuits and instant printed circuits. A new technique has recently become available to the hobbyist. It's a new concept of instant printed circuits that permits you to rapidly build projects directly from a schematic diagram. This new approach consists of a complete family of circuit sub-elements and associated circuit materials. With instant printed circuits there is no messy etching and in most instances you don't need to drill any holes.

**How-it-Works.** Dual buffer IC1 is the tone oscillator. Capacitor C1 and a set of tuning resistors—R9 through R19—provide a tuned musical scale. A note will sound-off when-

ever a probe is touched to one of eleven pads on the vibra-tone's keyboard. Since C1 is fixed for all of the notes, the pitch or musical tone is proportional to the total resistance at each position.

A second oscillator, which is part of IC3, (pins 1 to 7) provides a fixed low frequency of about 6 Hz, with C3 and R1. This signal is filtered and attenuated in R2 and C4, and fed back to pin 12 of the tone oscillator, IC1. This provides a periodic frequency modulation to the tones, which is an excellent vibrato. The tone output from IC1, pins 5 and 10, passes through resistor R5 to switch SW2 that selects this particular tone when it is closed. This same output from IC1 also goes to pin 2 of IC2, a dual J-K flip-flop. This integrated circuit provides two flip-flops, and each of these, by the natural binary count action, can divide any input frequency exactly by 2. This division by 2 produces two new frequencies exactly  $\frac{1}{2}$  and  $\frac{1}{4}$  the input frequency, these are the same notes one and two octaves lower.

**Changes Tone.** The first flip-flop output, pin 13 of IC2, is the one octave lower output. This goes through R6 to switch SW3.

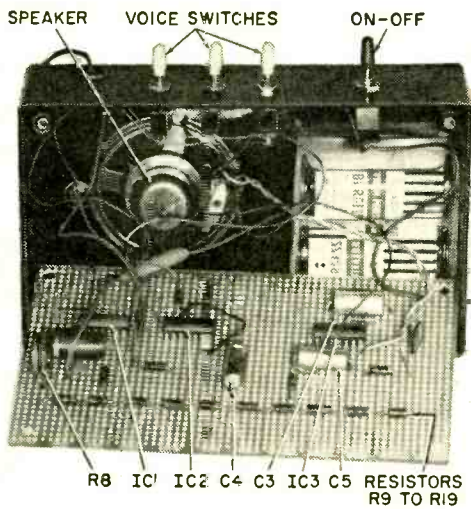

PHOTO BY MARVIN

Pin 13 also connects to pin 6 of IC2, the second flip-flop input. This provides a sec-

ond division by 2, providing a tone two octaves lower than the oscillator. The range switches, SW2 to SW4, are terminated on a common line which goes to pins 9 and 10 of IC3. Part of IC3 was used for the vibrato oscillator. However it also provides a simple two-stage audio amplifier. One of the gates (input 9, 10 and output pin 8) provides the first stage. Pin 8 drives pins 12 and 13 through C5. R4 provides bias. Pin 14 drives the 8-ohm speaker. C6 suppresses high frequency oscillations which might occur in this amplifier. The circuit operates on 3 volts, conveniently provided by two C cells in series, and draws approximately 120 mA standby current.

**Quick Put Down.** The instant printed circuit sub-elements consists of printed conductive patterns on a very thin epoxy glass board backed with pressure sensitive adhesive. Sub-elements are available for all types of integrated circuits, transistors, and other components, and, any combination of circuit element configuration can be mixed on one board. The circuit sub-elements are all pre-drilled with holes on a 0.100 inch grid. That is, they perfectly match the pattern of



Parts location suggestion when stick-on printed circuit construction is used. Wiring is applied to underside of board.



# VIBRA-TONE

0.100 inch vectorboard.

For this project, three 14-lead dual in-line printed circuit sub-elements are used. To use one of these sub-elements, strip off the protective backing and stick it in position, matching the holes in the printed circuit sub-element with holes in the vectorboard.

To use the conductive tape, hold one end and strip off its protective paper as the tape is laid down. A knife blade is then used to cut the tape. For best adhesion, roll the tape down with the side or heel of the knife. The adhesive on the copper tape is electrically conductive and, provided it is burnished for good adhesion, will make electrical contact. However, to eliminate any possibility of opens or intermittents, solder is

(Continued on page 118)

## PARTS LIST FOR VIBRATONE

- B1—Two C cells in series
- C1—0.1  $\mu$ F Mylar capacitor, 15 VDC or better
- C2—0.002  $\mu$ F disc capacitor, 15 VDC or better
- C3—10  $\mu$ F, 10 VDC electrolytic
- C4, C5—1  $\mu$ F, 10 VDC electrolytic
- IC1—Integrated circuit, HEP-571, MC799 or equal
- IC2—Integrated circuit, HEP-572, MC790 or equal
- IC3—Integrated circuit, HEP-570, MC724 or equal
- R1—6800-ohm,  $\frac{1}{4}$ -watt resistor
- R2—120,000-ohm,  $\frac{1}{4}$ -watt resistor
- R3—68,000-ohm,  $\frac{1}{4}$ -watt resistor
- R4—3300-ohm,  $\frac{1}{4}$ -watt resistor
- R5, 6, 7—22,000-ohm,  $\frac{1}{4}$ -watt resistor
- R8—1000-ohm, trim pot
- R9—1500-ohm,  $\frac{1}{4}$ -watt resistor, 5%
- R10—240-ohm,  $\frac{1}{4}$ -watt resistor, 5%
- R11, 12, 13—300-ohm,  $\frac{1}{4}$ -watt resistor, 5%
- R14—150-ohm,  $\frac{1}{4}$ -watt resistor, 5%
- R15—360-ohm  $\frac{1}{4}$ -watt resistor, 5%
- R16—430-ohm,  $\frac{1}{4}$ -watt resistor, 5%
- R17—510-ohm,  $\frac{1}{4}$ -watt resistor, 5%
- R18, 19—620-ohm,  $\frac{1}{4}$ -watt resistor, 5%
- SW1, 2, 3, 4—SPST toggle or slide switch
- Misc.—8-ohm speaker, battery holder, printed circuit material and board, cabinet, wire, solder, probe (banana plug or equal), etc.

Vectorboard and instant printed circuit material for this project are available for \$4.50 from Circuit Specialists Co., Box 3047, Scottsdale, AZ 85251

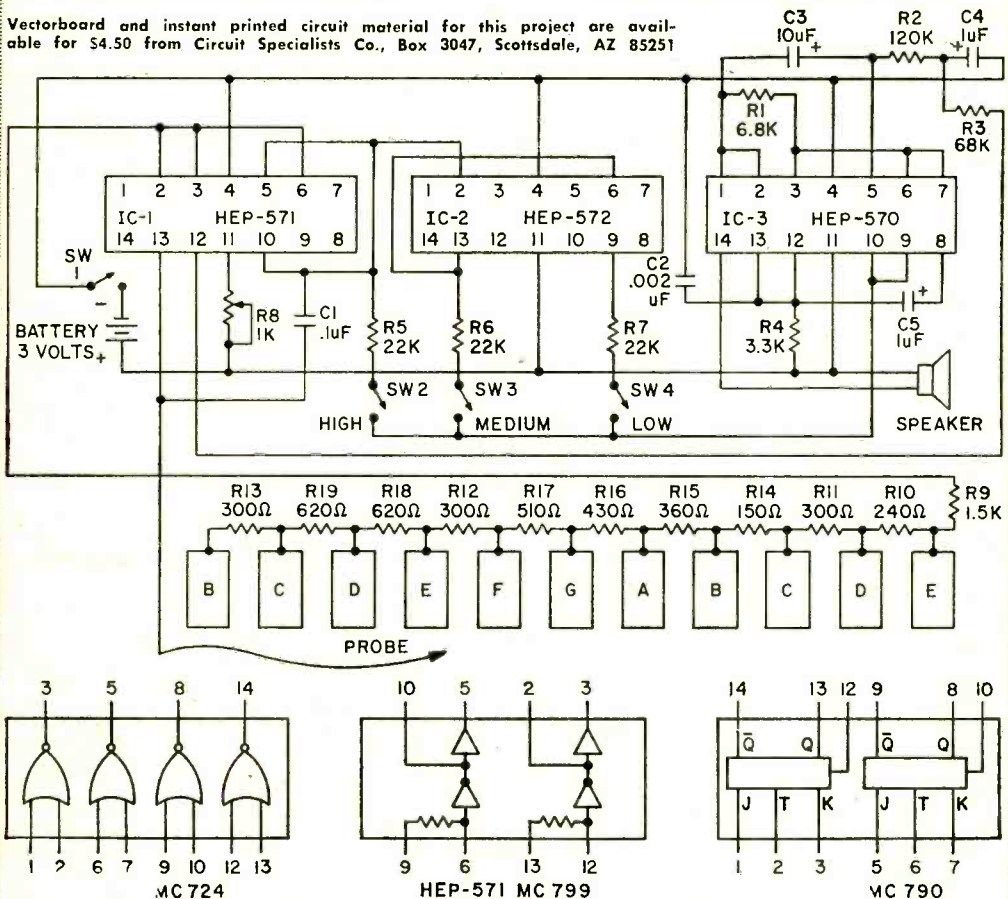



Snap Project for  
**Audiophiles**

build...

# BIG NINE

by David B. Weems

**A**ny good speaker should sound big, even if it's small. Big in the sense that it is expansive, which too often means expensive. Another way a speaker can sound big, to our conditioned ears, is with rich bass. A speaker that combines full bass with spacious highs will sound big at both ends of the audio range.

The big nine, described here, does just that. It offers big sound at a bargain price because you build your own wide-sound speaker system. Even with a high compliance 15-inch woofer for the bass and multi-directional high compliance mid-range speakers and dome tweeters for the highs, your speaker cost is only about \$65.00 per enclosure. And you can make two big nine enclosures from



# Big Nine

only 1½ sheets of ¾-inch unfinished plywood. A few tools are all you need, particularly if you have your local lumber yard cut out the parts for you.

After getting the parts home, mark and cut out the speaker holes at the proper locations (see Fig. 1). The outside edges of the

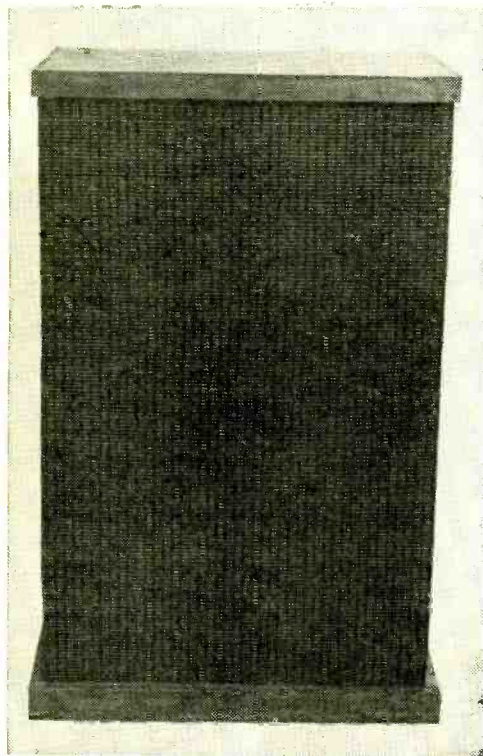

An assembled Big Nine stands a full three feet tall, nearly two feet wide. Trim both top and bottom after stapling grill cloth.

holes for the mid-range speakers and the tweeters should be beveled off with sandpaper, a file, or a sabre saw set at 45°. If left intact, the sharp edge at the outside of the speaker panels can cause diffraction and interference effects which will affect the mid-range and high-frequency response.

**Speaker Cutouts.** Select a sample speaker of each size and center it at each speaker hole. Mark the location of pilot holes for speaker mounting screws. Drill 3/32-inch pilot holes for the mid-range speakers and tweeters. For the woofers drill ¼-inch holes at each mark and install "T-nuts" from the

front of the board to receive 3/16-inch stove bolts. If you can't find 3/16-inch T-nuts, you can substitute slightly longer 3/16-inch flathead stove bolts installed from the front.

Next set up the parts on your work bench to form a partial enclosure. Mark a line

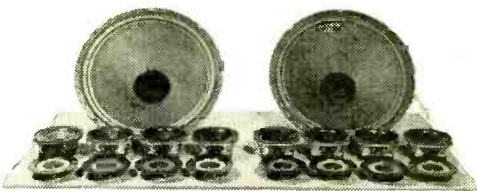

A total of eighteen speakers fill your room with a powerful sound. Fifteen inch woofer has a polyfoam suspension and low resonance.

where the edge of a panel butts against another panel. For example, you will mark lines on the bottom and sides to outline the edge of the front panel when the front is flush with the front edges of the other panels. You will also mark lines on the bottom to show the inner edges of the sides, and so on until you have outlined the position of each panel. Next measure and cut glue blocks to fit each corner location. The approximate length of the glue blocks is given in the bill of materials, but you may find that minor differences in panel dimensions will require these lengths to be trimmed or increased slightly.

Now attach glue blocks to panels, using glue and screws. It is much easier to install all the glue blocks at once, with the panels flat on your work bench, than later after the panel is fastened to another panel. Drill shank holes of about 13/64-inch through

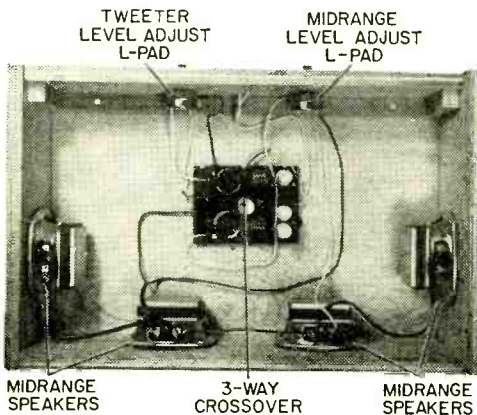

Remove top cover to see L-pads, crossover network, and the four mid-range speakers. Parts substitutions are possible. See text.





# Big Nine

Now install the mid-range speakers with screws and the woofer with bolts. Both mid-range units and the woofer have adequate gaskets, no caulking compound needed. The mid-range speakers should be mounted upside down so that their terminals are pointed up for easy wiring.

Install the crossover network with four non-magnetic screws, aluminum or brass, and with "spacers" between the crossover network board and the partition. Pieces of plastic tubing or rubber grommets about  $\frac{3}{8}$ -inch long will serve as spacers or stand offs. After the screws are installed, tap the network board lightly and check for rattles. If loose, the board will tend to "sing," but not very musically.

Drill two  $\frac{1}{4}$ -inch holes through the mid-range back (H), for the speaker leads.

Ream the holes on the outside of the back so that a two-terminal strip, screw type, will fit flush against the back. Split a 12-inch piece of lamp cord far enough to feed the two leads through the holes from the inside of the back, and solder them to the terminal strip. Install the strip with glue and small screws.

**Install The Controls.** Drill  $\frac{3}{8}$ -inch holes for the control shafts; then enlarge the holes on the outside surface with a  $\frac{3}{4}$ -inch drill to recess the retaining nuts. Tighten the nuts on the shafts, then stick the control plates on the back with contact cement. Install the mid-range back panel with screws —no glue.

Wire the speakers using lamp cord for conductors. The logical first step in speaker wiring is to connect the paralleled pairs of mid-range and tweeters. Wire the left pair of each in parallel, and the right pair of each in parallel. Use care to see that the same conductor on a piece of lamp

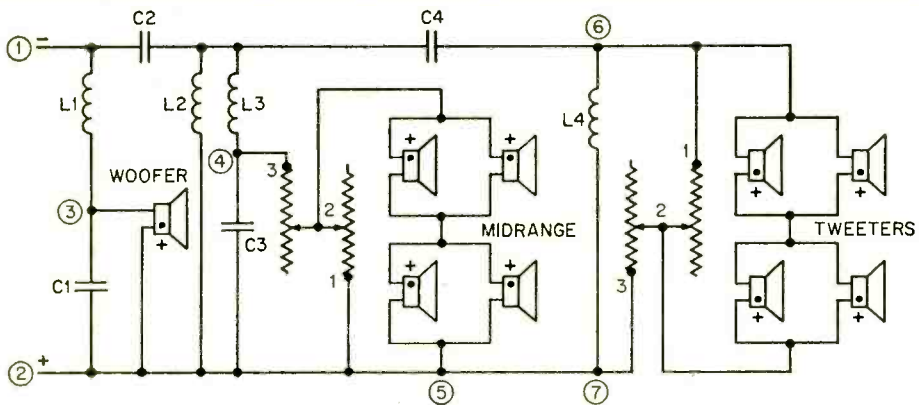
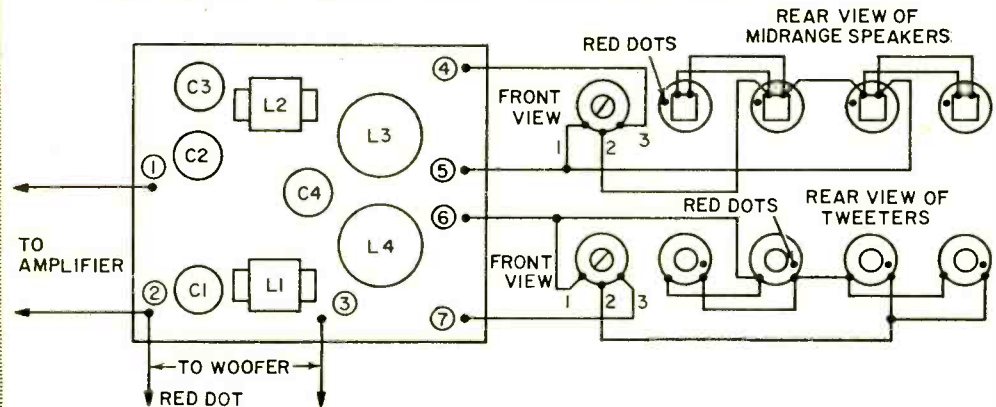

Figure 2, above, shows the Big Nine wiring diagram for bill of material parts.

Figure 3, below, is a pictorial wiring of the speakers, L-pads, and crossover.



cord goes to the red dot on each speaker in the pair. After the pairs are wired, connect the pairs together by a single conductor from the red dot terminal on one pair to the unmarked terminal on another pair. This puts the two parallel pairs in series when the four speakers are wired by connecting the proper tap on the crossover network through the control to the red dot on one pair and the unmarked terminal on the other pair. (See Figures #2 and #3.)

In order to keep the wiring straight, it's a good idea to split several pieces of brown lamp cord and equal lengths of white lamp cord. Use the individual leads to connect the speaker to the network and controls, a brown lead for negative and a white lead

for positive, or vice versa. The leads to the woofer and tweeters can be carried through the partition through two ¼-inch holes. After wiring, fill the space at each end of the holes with caulking compound.

**Check For Phase.** Before soldering the speaker wires, hook up the system to an amplifier or other source and test to see if the speakers and controls are working right. Keep the volume low when the back is off. You should hear bass from the woofer, mid-range from the squawkers, and highs from the tweeters. Now listen to each mid-range speaker in turn, without changing any controls on the amplifier or the speakers. Each of the four speakers should

*(Continued on page 116)*

### Bill of Materials for Big Nine

Quantity	Speakers, Network and Controls	
1	15 in. high compliance woofer (CTS-FR-15-20-8)	about \$19.95 each
4	5 in. high compliance speakers (XS-510)	about 3.99 each
4	3 in. tweeters (CTS-2TA3)	about 3.95 each
1	3-way crossover network, Norelco (4304-07X)	about 7.95 each
2	8-ohm L-pads (Radio Shack 40-980 or equiv.)	about 1.99 each
	See Hints-On-Parts for more information.	
	<b>¾-in. Plywood</b>	
1	20¼ x 36-in. front panel (A)	
1	20¼ x 29⅞-in back (B)	
2	13¾ x 36-in. sides (C, D)	
2	13¾ x 21¾-in. top and bottom (E, G)	
1	13 x 20¼-in. partition (F)	
1	5¼ x 20¼-in. M-R back (H)	
	<b>¾ x ¾-in. Pine Blocks</b>	
4	28¼-in. Vertical side blocks	
6	20¼-in. Bottom and partition front and back, top rear	
4	10¾-in. Bottom and partition sides	
	<b>Trim</b>	
2	13¾ x 1½ x ¼-in. Top	
1	22¼ x 1½ x ¼-in. Top	
2	13¾ x 2 x ¾-in. Base (sides)	
1	23¼ x 2 x ¾-in. Base (front)	
	<b>Miscellaneous</b>	
150	Grille cloth, approx. 52 x 36-in.	
32	#8 x 1¼-in. flathead wood screws	
32	#8 x ¾-in. panhead sheet metal screws (mid-range speaker mounting)	
8	#8 x ½-in. panhead sheet metal screws (tweeters)	
8	3/16-in. T-nuts	
8	3/16 x 1¼-in. round head stove bolts with washers (woofer mounting)	
	Flat black paint, terminal strip, lamp cord, glue, etc.	





# Keep a Light Flashing in the Window

□ The night is dark, rain is falling and the parking lot is dismal. Where the heck is your car? That's easy—right over there under that twinkling star! Well, it's not a star but one of those 3-volt thermal-blink lights found in so many kids toys.

You, too, can be fortunate if you plan in advance. In fact, plan for others. Build a blinking light for your doorway or driveway, if all the houses on your street are similar. This way visitors can look for the twinkling star and find you pronto.

Hyman Wallin of Silver Spring, Maryland did just that and sent a sample to the Editors of *ELEMENTARY ELECTRONICS*. He soldered the bulb directly to a terminal strip yanked from a defective transistor battery. Next, he snapped it to a two-cell battery holder that mated the snap terminals on the battery strip. It's that easy. Mr. Wallin used C cells, but anything larger will be good and last longer. You can cement an alligator clip for fastening purposes. Lights out!  
—Emmett Fluffin

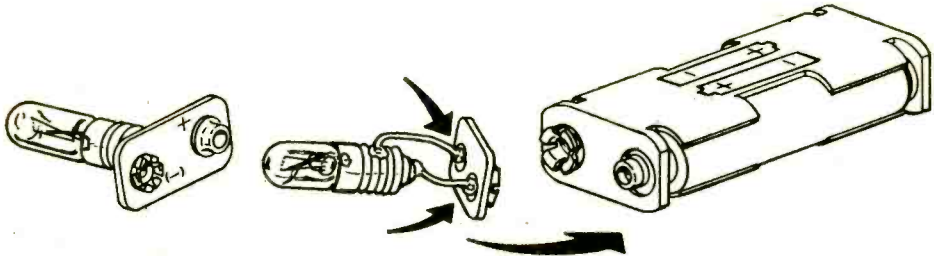

## Groove Booster

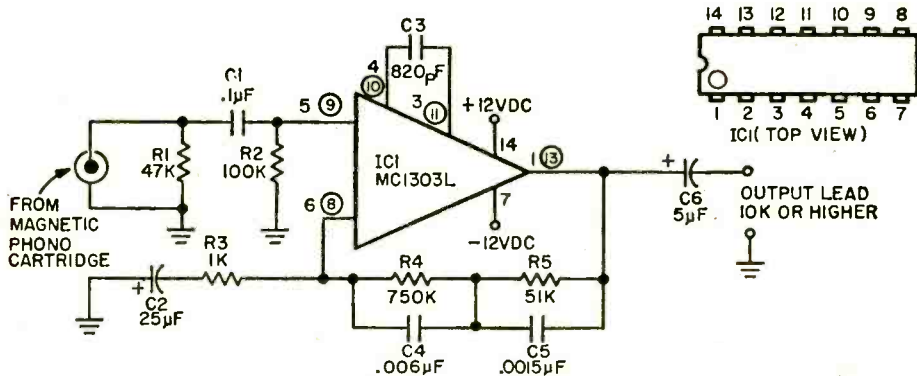

Using a dual operational amplifier IC, the Groove Booster will provide a fully equalized 1 V rms output from standard phono magnetic pickups. The terminal numbers which are circled on the schematic are the connections for one of the two independent stereo amplifiers on the single IC chip. The uncircled numbers are the terminals for the stereo second IC. Power supply terminals #14 and #7 are common to both stereo amplifiers. Note that the power supply is  $\pm 12$  volts to ground. Two 6 volt batteries in series can be used for each side of the power supply. If batteries are used, connect 25  $\mu\text{F}$  capacitors from

pins 7 and 14 to ground—and get their polarity correct. ■

### PARTS LIST

- C1—0.1  $\mu\text{F}$ , 3 VDC
- C2—25  $\mu\text{F}$ , 3 VDC
- C3—820 pF, 500V VDC disc
- C4—0.006  $\mu\text{F}$ , 100V VDC disc
- C5—0.0015  $\mu\text{F}$ , 100V VDC disc
- C6—5  $\mu\text{F}$ , 25 VDC
- IC1—Motorola MC1303L
- R1—47,000-ohms, 1/2-watt
- R2—100,000-ohms, 1/2-watt
- R3—1,000-ohms, 1/2-watt
- R4—750,000-ohms, 1/2-watt
- R5—51,000-ohms, 1/2-watt

# Super Booster

**Add this devilishly simple RF booster to any Broadcast Band rig, and watch the once dead BC Band come alive—by Lars Jorgensen**

Imagine your receiver's broadcast band dial jammed from end to end with a solid wall of signals! Pip-squeek stations that normally can't be heard with headphones *can* come booming into your shack at \$9. A dream? Nope! That's just the kind of performance you'll get with Electronics Hobbyist's Super Booster.

Here's a preamplifier specifically designed for BC DX'ers. Whether you live in a concrete and steel tower, or out in the boondocks with plenty of space for a long-wire antenna, the Super Booster will dig out signals you've never heard before. The average gain of Super Booster is almost 42 dB—that's 7 S-units "extra" sensitivity!

As shown in our figure, the booster can function either as an "electronic antenna", with signals received only by loopstick antenna coil L1, or as a preamplifier, with long-wire antenna signals coupled to L1 through L2. Coil L2 is supplied as part of the specified antenna loopstick; you have no coil winding problems.

Signal voltage appearing across L1 and C1 is coupled to Field Effect Transistor Q1 which provides approximately 20 dB gain on top of the L1/C1 resonant gain. The output of Q1 feeds

transistor Q2, connected as an emitter-follower. This transistor stage provides an additional 10 to 15 dB power gain, and also provides a low-impedance output for connection to the relatively low impedance receiver input.

Though intended for direct connection to a receiver's antenna input terminals, CW's super Booster can also be used with "loop antenna radios" by connecting the booster's output to a loopstick antenna (a duplicate of L1), and then positioning this loopstick near the radio. We'll show how both connections are used.

The total current drain of Super Booster is less than 2 mA. Power is provided by a standard 9V transistor radio battery. The 2U6 type will last at least 3 months, even under heavy service. An "activator" type battery can last a year or more. With such low power consumption, there is no reason to build an external AC power supply for Super Booster.

**—Construction.** Though the circuit appears very simple, extreme care must be taken in the circuit board preparation. Reason is, the very high gain can cause total instability if a single component, or printed foil-circuit is out of position. We suggest that no attempt be made to use point-to-point wiring; use a PC board which is an exact copy of the supplied template. The board can be of type XXXP; there is no need for a more expensive board.

Make no component substitutions; Q1 and Q2 should be the specified types. Through the circuit might work with some "general purpose replacement type NPN and MOS tran-

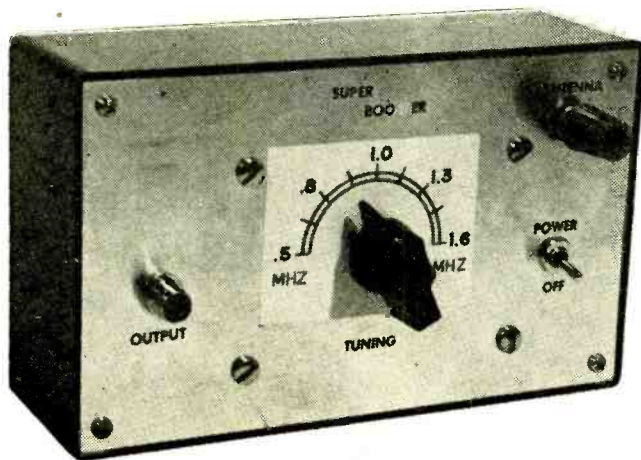



# SUPER BOOSTER

Placement diagram for SB's parts. If the output is fed to an AC/DC-type rig, disconnect the link and ground J2's cold end separately.

sisters," it probably won't work with other dime-a-cheapies. Worse yet, it might work only on very weak signals while distorting on strong signals.

The specified components will provide distortion-free performance on signals as high as 80,000  $\mu$ V. You can expect Super Booster to provide its great performance until the battery voltage falls below 6 volts.

The circuit board and a *very short* connection to output jack J2 are the only critical assemblies. You may make mechanical modifications to Super Booster as long as the general layout approximates the unit shown in the photographs. Any cabinet can be used; the PC board has a built-in hand-capacitance shield. For maximum stability, though, a metal front panel will reduce the possibility of RF instability caused by the signal being fed into the receiver radiating back into the booster's input

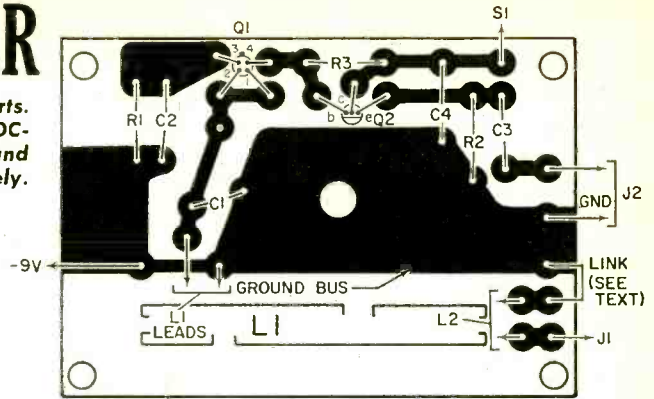

**—Making the PC Board.** Cut a piece of copper-clad board to the size of the template and scrub the copper surface clean with a strong household cleanser such as Ajax. Or, use steel wool and a liquid detergent. Place a piece of carbon paper (carbon side towards the copper) over the board and tape the board under the template. Next, find a sharp pointed instrument, such as an ice-pick or scriber, and indent the copper foil at each component mounting hole by forcing the point of the tool through the template and into the copper. Use only hand pressure, not a hammer. Then, using a ball

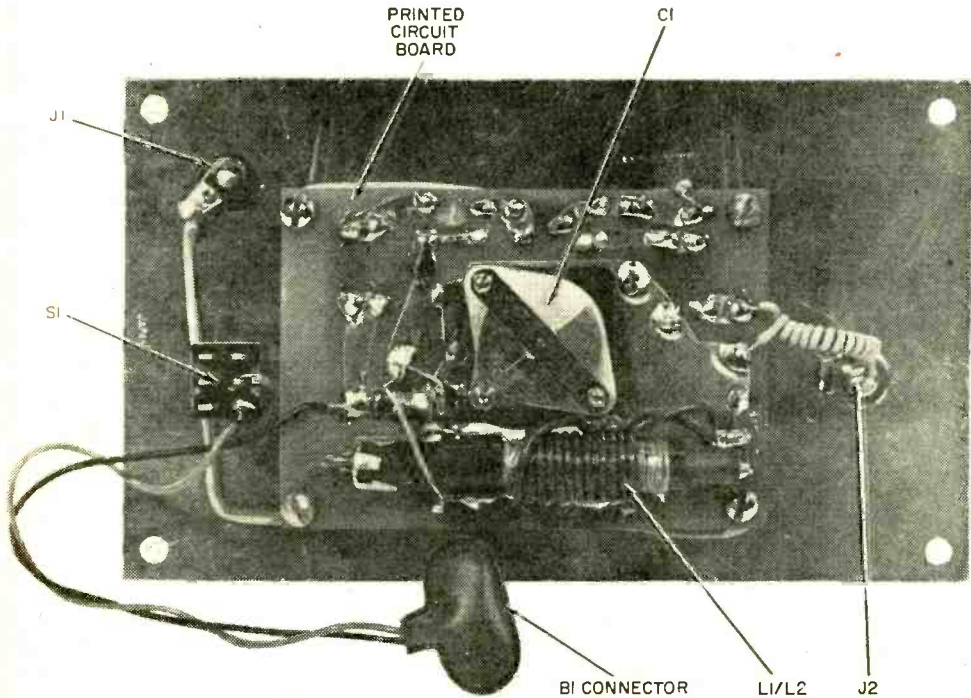

This is Super Booster's printed circuit board drawn full-size. If you make your own PC board, follow this pattern exactly; RF instability, or regeneration, could result if you don't.

Our diagram shows where the various components are mounted on this PC board. Follow the layout carefully.

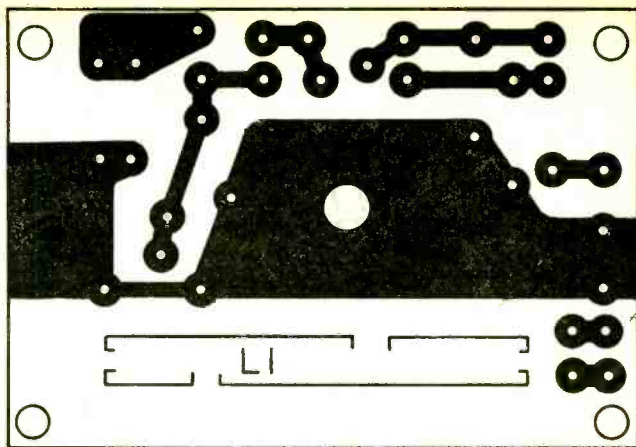

point pen, trace the outline of each foil area.

Remove the board, discard the carbon paper, and fill in the outlines with a resist pen such as supplied in the Allied Radio Shack printed circuit board kits. Allow about 15 minutes for the resist to dry and then immerse the board under at least 1/4" of etchant.

When all the excess copper is dissolved—about 45 minutes later—rinse the board thoroughly and remove the resist with a cloth moistened in rubber

cement thinner or by scrubbing with steel wool.

All of Super Booster's component mounting holes, except the one for tuning capacitor C1, are drilled with a number 58, 59 or 60 bit. Capacitor C1 requires a 3/16" mounting hole. The holes in the corner of the PC board, used for mounting the completed PC assembly, should clear #4 or #6 screws—which-ever you prefer.

The PC board is best assembled in the following manner: install capaci-

#### PARTS LIST FOR SUPER BOOSTER

- B1—9 volt transistor radio battery (Burgess type 2U6 or equiv.)
- C1—365 pF subminiature poly-type variable capacitor
- C2,C3,C4—0.05  $\mu$ F, 50 VDC disc ceramic capacitor
- J1—5-way universal binding post
- J2—RCA-type phono jack
- L1—loopstick antenna
- L2—loopstick antenna (optinal for radios without antenna terminals—see text)
- PL1—RCA-type phono plug—see text
- Q1—dual gate mosfet n-channel transistor (RCA 40600)
- Q2—bipolar npn transistor (G.E. 2N 3394)

- R1—1,000-ohms, 1/2-watt composition resistor, 10% tolerance
  - R2,R3—4,700-ohms 1/2-watt composition resistor, 10% tolerance
  - S1—single pole, single throw switch
- A complete set of components, including J1,J2, S1,B1, and an undrilled printed circuit board is available for \$13.95 (includes postage) from the Electronic Hobby Shop, Box 587, Brooklyn, N.Y. 11202. Add \$1 for antenna loopstick L3 if needed. Canadian add \$2 extra. New York state residents must add sales tax. No foreign orders, please. Speedy service offered when postal money order accompanies order. Otherwise allow 6-8 weeks for delivery.

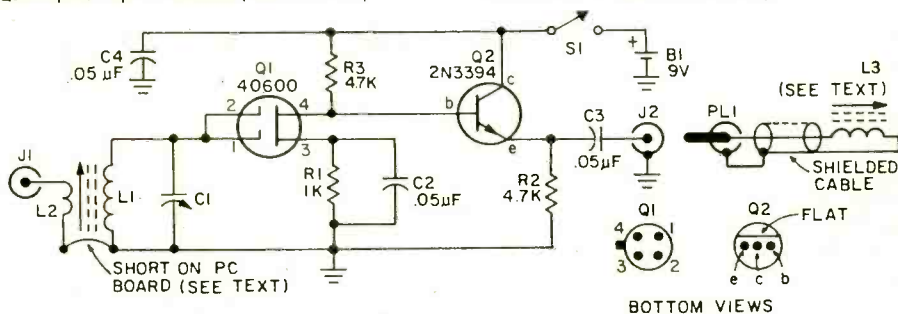



# SUPER BOOSTER

tor C1 first, then all other components except Q1. Then push Q1's leads through the holes in the PC board and solder them home. Finally, solder the two power leads to their respective points if you intend to check out the booster before installation in the cabinet.

Note that Q1 is supplied with a shorting clip around all the leads. *This clip must be left in position until the booster is completed and ready for operation.* If the clip is removed, a high static voltage from the tip of the soldering iron, or a voltage generated through normal handling, might destroy Q1.

Position transistor Q1 so that the tab sticking out from the case faces the nearest edge of the PC board. Position transistor Q2 so that the round side of the case faces the nearest edge of the PC board; the flat side faces the far edge of the PC board.

Note that there are no crossed leads for Q1 and Q2. When they are oriented so the tab and round end are properly aligned, the transistor leads will plug straight into the board.

Note that L2's leads have individual printed foil connections. Normally, one foil is connected to the boosters' ground through a shorting wire. The remaining foil connects to antenna jack J1. If, for some reason, you prefer a separate antenna ground, open the shorting wire and install a "ground" jack on the panel. Connect the proper foil to the ground jack.

Because the components are mounted on the side of the pc board facing the cabinet panel, stand-offs must space the board away from the panel. You'll find, however, that C1's tuning shaft will be too short to pass through the panel for application of a tuning knob. But the cure's simple enough; simply cut off a section of shaft from an old potentiometer and epoxy-cement the section to C1's shaft. Or, use a plastic extension sleeve (such as the type supplied for "insulated shaft" potentiometers); the sleeve is rigid to support a knob.

The loopstick coil is cemented to the board with General Electric's RTV Silicon Rubber adhesive. Use no other

brand or type of adhesive. Other brands, such as Dow-Corning's Silastic, are conductive at RF frequencies, and will ruin the electrical properties of the coil.

Check that the foil area outlined on the board has the indicated "breaks". You don't want a closed loop. If you forgot and made a closed loop, cut four breaks as indicated with a knife or hand grinder. Apply a thin layer of Silicon Rubber adhesive inside the marked coil area and press L1-L2 into the adhesive. Make certain L1's connection terminals are parallel to the board, with L2's leads away from the board. Then allow sufficient time for the adhesive to dry.

We suggest you check out the PC assembly before it is installed in a cabinet. Remember to remove Q1's shorting clip! Simply pull on the end of the clip with long nose pliers and the clip will unwind from around Q1's leads.

Connect a DC milliammeter rated at 5 mA or higher between the battery's positive terminal and the board's positive foil. Connect the battery's negative terminal to the board's negative foil. The meter should indicate slightly less than 2 mA. If the meter indicates 1 mA or less, or more than 2.5 mA, check for a component mixup or incorrect installation of Q1 and Q2. If the meter reading is correct, disconnect power and install the board in a cabinet.

We recommend a plastic cabinet with aluminum panel such as shown in the photographs. The plastic cabinet allows direct signal pickup by the loopstick, which will be more than adequate for most DX'ing. Keep antenna jack J1 as far as possible from coil L1. Keep output jack J2 as close as possible to the board's output terminals. The power and antenna input leads should be flat against the panel.

Make up a short, shielded output lead by wrapping a solid-conductor, insulated wire around another wire. Keep the wrap turns against each other. Using the shortest possible length of this shielded wire, connect J2 to the board's output terminals. Make certain the "ground" wire goes from J2's ground lug to the ground foil.

Adjust L1's slug clockwise with a small screwdriver until only  $\frac{1}{4}$ " of the slug's adjusting screw sticks out of the coil form. The other end of this screw,

*(Continued on page 90)*

# DON'T BUY A NEW CAR OR LIGHT TRUCK UNTIL YOU BUY A COPY OF...



**AutoFacts Keeps on Scoring for Consumers!**  
**Dan Carrigan of New Orleans La. writes—**

"I have to let you know how grateful my wife and I are to your publication. We just ordered our first new vehicle and got a great deal thanks to AutoFacts! Armed with the specific cost information we did battle with local dealerships. I found that just showing the manager my AutoFacts book had an amazingly disarming effect. When all was said and done we had saved \$1010 from the quoted price of the first dealership we consulted. Keep up the good work—we appreciate you!"

signed/Dan Carrigan

## SPECIAL BONUS FOR AUTOFACTS READERS!

\* How to get a new car for only \$125 over dealer's cost.

Through the United Auto Brokers' Car/Puter organization, you can take delivery, without delay, of a brand new car for just \$125 over cost. Your purchase includes freight and pre-delivery service. You take delivery of a new car of your choice from a local dealer and you get the same new car warranty and service as if you had paid full list. Car/Puter's 48-hour computerized service that helps you make the best new car deal on your own.

\* Certain limited production or specialty models priced higher. Some foreign models not available.

"... valuable for the consumer in the market for a car. Car/Puter's AutoFacts lists the 'dealer' (wholesale) costs of new cars with all optional extras itemized and of many used cars. For comparison shopping or nitty-gritty haggling—invaluable."  
 —from The New York Times Book Review

**AutoFacts—**

- ✓ makes you a smarter buyer!
- ✓ can save you up to \$1000!
- ✓ helps tailor your purchase to your pocketbook!
- ✓ tells you whether you're being offered a good deal or not!

## NOW ON ALL LEADING NEWSSTANDS

If you prefer, complete and mail this coupon to Car/Puter's AUTOFACTS, Davis Publications, 229 Park Avenue South, New York, New York 10003.

- Send 1974 New Car Yearbook and Buying Guide. Payment enclosed of \$1.50 plus 25¢ for postage and handling.
- Send AUTOFACTS 1974 New Car Prices edition. Payment enclosed of \$1.50 plus 25¢ for postage and handling.

**NOTE:** Write publisher for bulk rates. Add \$1.00 per issue for orders outside Continental U.S.A. and Canada.

- I prefer a full year's subscription of four issues (1974 New Car Yearbook and Buying Guide; 1974 New Car Prices edition; 1974 Spring/Summer New Car Prices edition; Spring/Summer 1974 Used Car Prices edition).

\$6.00 for full subscription is enclosed.

name \_\_\_\_\_ (please print)

address \_\_\_\_\_

city \_\_\_\_\_ state \_\_\_\_\_ zip \_\_\_\_\_ DR-AFX

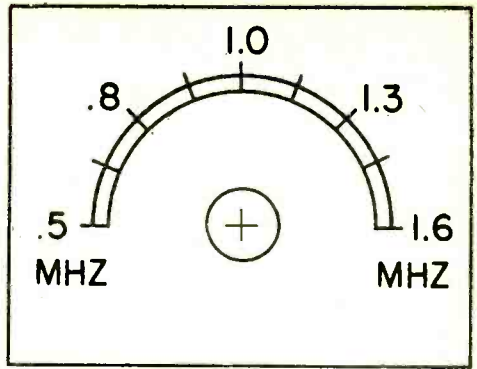
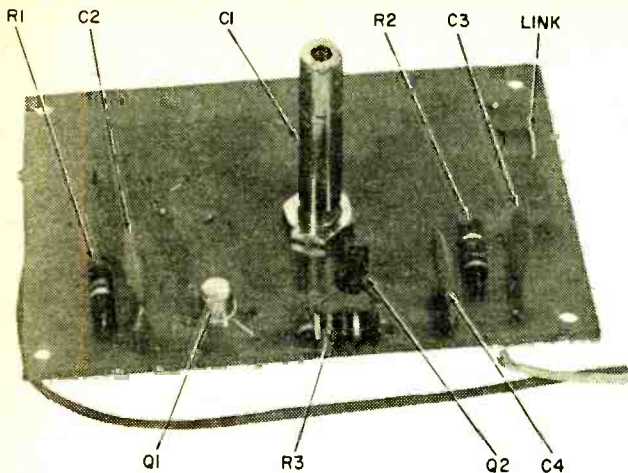

Here's what finished PC board looks like before it's mounted to front panel with standoffs. Tuning dial faceplate can be used as is; just paste it down!

(Continued from page 86)

the slug itself, will protrude about  $\frac{1}{4}$ " out the end of the form. The slug is generally secured with wax, so the first turn or two might require a little extra force; don't be afraid to adjust the slug if it "feels" tight.

Make up a connecting lead to go from output jack J2 to the receiver's antenna terminals. Any shielded wire or coaxial cable can be used. Install a phono plug on one end. For least signal attenuation, the lead should not exceed 15 inches.

If the Super Booster will be used with a transistor radio having a built-in loop antenna and no external antenna terminals, connect the free end of the output lead to a loopstick antenna—merely an exact duplicate of L1! If the loopstick has an antenna winding, such as found on the specified loopstick, simply unwind the few turns and connect the output lead to the coil's solder terminals. Position this coil on the radio's case opposite its built-in antenna and tape the coil in position.

**—Using Super Booster.** Turn on both the receiver and booster and tune in the desired station. Adjust tuning capacitor C1 for maximum signal strength or highest S-meter reading. As a general rule, the direct signal pickup by L1 will be more than adequate. If greater sensitivity is needed, connect 6 to 15 feet of wire to antenna jack J1. If you have the space needed for an outdoor longwire antenna, take note that the signal level into the receiver can be so high as to overload the receiver.

If there is a strong local station in

your area, it is possible that its signal strength will be so greatly boosted that it might swamp the receiver when listening to a weak signal on the other end of the dial. If this occurs, simply detune the booster away from the strong local until its interference is gone. While this might sacrifice some gain on the desired station, the actual loss will be slight.

It is possible that the booster's output might radiate back into the input (particularly when using a loopstick coupling coil). You'll know when this happens—the booster breaks into self-oscillation—as evidenced by receiver blocking, or signals being tuned in and then "lost" when C1 is adjusted. If this happens, position the booster as far away from the receiver as possible. And, keep an external antenna, if used, well away from the receiver and the booster's output. Do this, and under normal conditions, there should be no instability.

Under certain conditions Super Booster will provide an additional benefit which should not be construed as improper operation. Some inexpensive rigs are highly prone to marine band "image" interference when signals at the high end of the BC band are received. The booster, by providing tuned pre-selection, will eliminate or suppress these images while providing signal amplification. Do not assume the loss of image interference means reduced sensitivity; actually, the desired signal will be getting full boost while the image signals are squashed. ■



build e/e's...

# SCRAMBLE PHONE

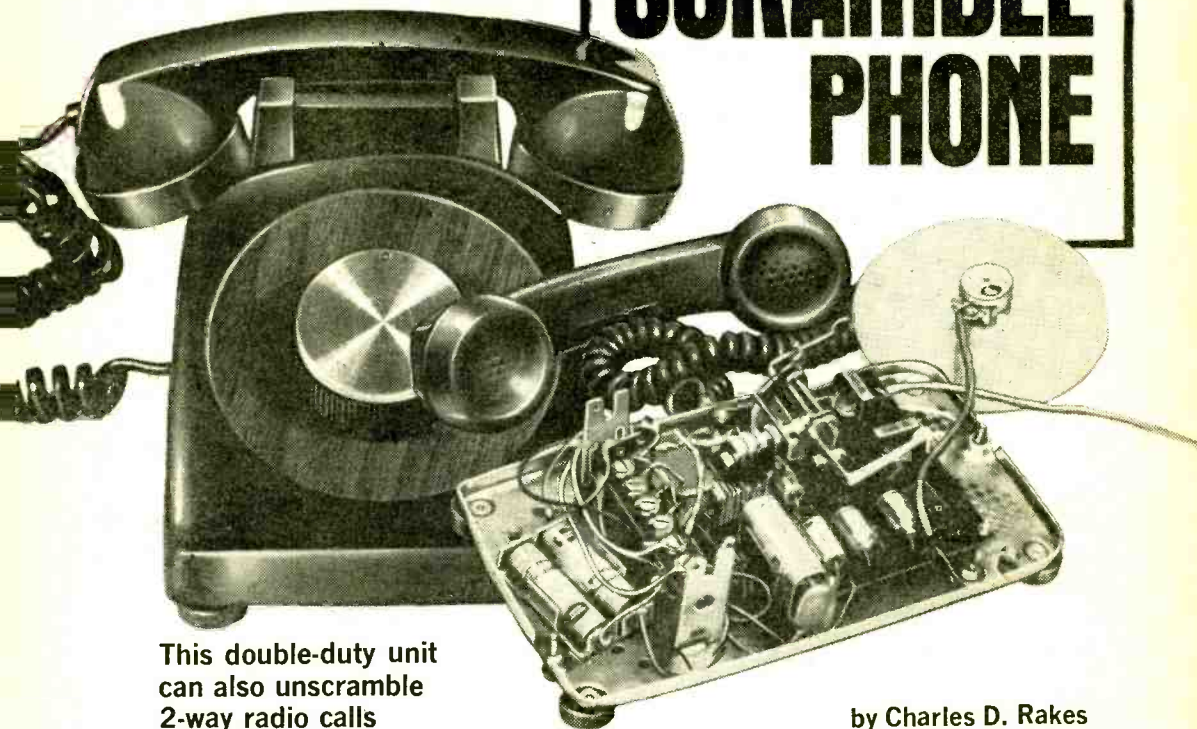

**This double-duty unit  
can also unscramble  
2-way radio calls**

by Charles D. Rakes

**D**emand ultimate privacy in your telephone conversations? If so, a secure phone link can be yours with these three easy and exciting steps. 1. Place your call with Ma Bell's instrument. 2. When your party answers, switch to your special scrambler phones. 3. A soft buzz in the ear piece says your security phone link is operational. Your line is secure. Conduct your call in complete privacy no matter how many ears are party-line-listening!

All it takes is a pair of **ELECTRONICS HOBBYIST** Scramble Phones. And with this double duty unit, you can try your hand at decoding scrambled conversations that are sometimes heard on radio receivers covering the VHF high band (148-176 MHz). The basic scrambler circuit (available in kit form, see parts list) can be simply modified for radio by removing two fixed resistors and replacing them with a dual-potentiometer.

Wait a minute! Before your soldering iron overheats, let me say that this scrambler will decode information that is encoded in the *single inversion* mode only. The highly sophisticated scramblers that are sometimes

used today can not be decoded with this decoder, but in many areas the single inversion system is still in use and may be decoded with our unit.

**How It Works.** IC-1 and the associated circuitry form a stable audio tone generator which feeds a buffer amplifier, Q1 and Q2. The tone output is taken from the emitters of the transistor pair to supply a carrier voltage for a balanced modulator made up of four diodes—D1 through D4—and T1 and T2. If the two transformers and the four diodes are perfectly matched (which is almost impossible to achieve and not necessary in any case) no carrier will appear at the input or output of T1 or T2. In a practical circuit, a small amount of unbalance will occur and produce a low-level carrier tone at the input and output of the balanced modulator. This tells you your scramble phone is working.

A telephone carbon mike and ear piece are connected to the low impedance winding of T1, with a three volt battery supplying the necessary mike current. When the mike is spoken into, the carrier voltage is allowed to pass, in part, through transform-

## SCRAMBLE PHONE

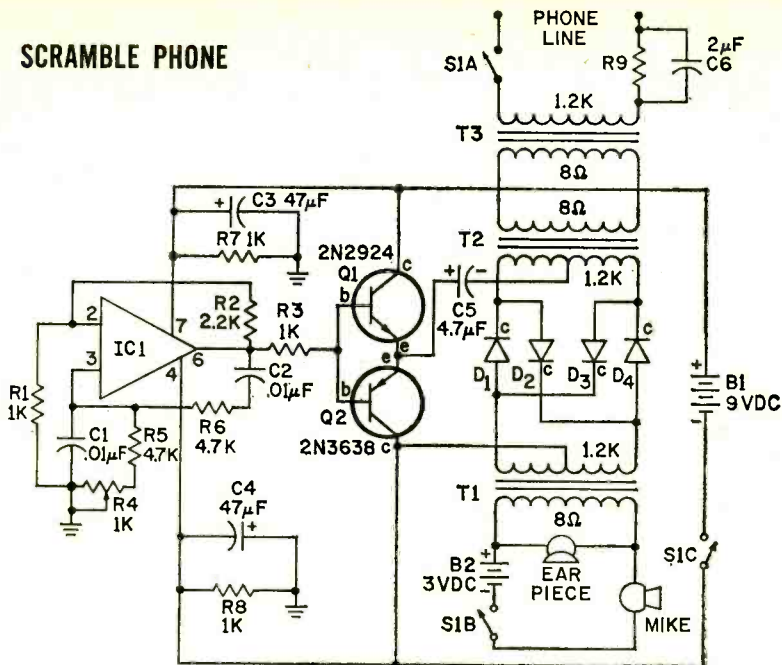

### PARTS LIST FOR SCRAMBLE PHONE

B1—9-volt battery, Eveready 216 or equiv.  
 B2—3-volt battery, two AA penlight cells in series  
 C1, C2—0.01  $\mu$ F polystyrene capacitor, 100 VDC or better  
 C3, C4—47  $\mu$ F electrolytic capacitor, 25 VDC or better  
 C5—4.7  $\mu$ F electrolytic capacitor, 25 VDC or better  
 C6—2  $\mu$ F paper or mylar capacitor, 50 VDC or better  
 D1 to D4—Diode, IN914, HEP-156  
 IC1—Integrated circuit, Signetics N5741K or equiv.  
 Q1—NPN transistor, 2N2924, HEP-724  
 Q2—PNP transistor, 2N3638, HEP-716  
 R1, R3, R7, R8—1000-ohm,  $\frac{1}{2}$ -watt resistor  
 R2—2,200-ohm  $\frac{1}{2}$ -watt resistor

R4—1000-ohm potentiometer  
 R5, R6—4,700-ohm,  $\frac{1}{2}$ -watt resistor  
 R9—Limit line current to 25mA (see text)  
 S1A, S1B, S1C—Phone hook switch (see text)  
 T1 to T3—Small transistor audio transformer; 8-ohm primary, 1,200-ohm center taped secondary.

Misc.—Surplus telephone (see Lafayette, Radio Shack, EDI, BA catalogs), battery holders, hardware, knob, wire, solder, etc.

An etched and drilled printed circuit board is available for \$4.95 (includes postage and handling). A complete kit of all parts that mount on the PC board, plus the drilled board and R4 are available for \$16.95 (one kit) and \$30.95 (two kits). Add one dollar (Canadians add \$2) for handling when ordering the complete kit(s). Postal Money Order speeds shipment. Order from KRYSTAL KITS, Highway 102 East, Bentonville AR 72712.

ers T2 and T3, and on to the telephone network. The only purpose of T3 is to match the impedance offered by most telephone lines.

Trim potentiometer R4 is used to make a fine frequency adjustment of the oscillator so that two scrambler units may be synchronized to the same carrier frequency. Both oscillators must be operating at the same frequency to produce the best decoded speech quality. This control is referred to as the speech *clarity* control.

The best overall carrier frequency range to use for speech scrambling is between 2 kHz and 3.5 kHz.

**Listening In.** If the scramble phone is to be used for only receiver speech decoding, then only one unit is required. The operation is much the same as for telephone encoder/decoder purposes, with the exception that it is used only as a decoder. The carrier oscillator is made variable so the decoder may be synchronized to the same carrier frequency as is used in the encoder. The output of the receiver is connected to the 8-ohm winding of T2 (T3 is not required for this use) and the decoded information is developed across the 8-ohm winding of T1. A small speaker may be connected across this winding, or a low impedance ear-







## SCRAMBLE PHONE

### MODIFICATION 1.

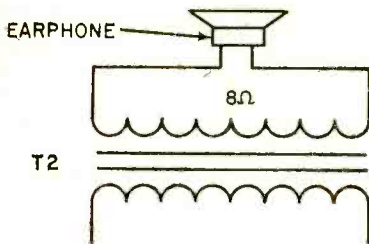

REMOVE T3, ADD EARPHONE

### MODIFICATION 2.

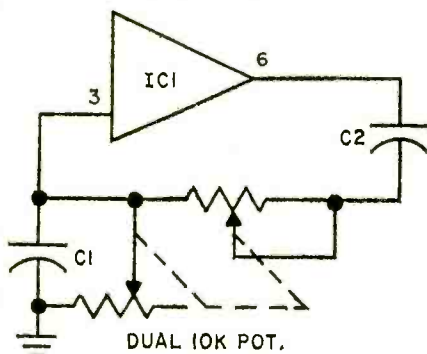

ADD DUAL POT, REMOVE R4, R5 AND R6.

### MODIFICATION 3.

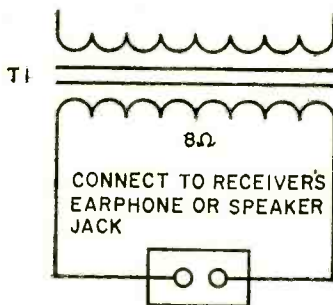

REMOVE PHONE HANDSET AND 3-VOLT BATTERY, ADD TERMINAL STRIP

It is possible to decode some older scrambler systems heard on 2-way radio bands. However, this single inversion mode circuit will not work with multi-inversion systems also in use. Dual pot is Allen-Bradley CJK1N200P103U or equiv.

phone will do for monitoring the decoded speech. No mike or 3-volt battery is necessary for decoding operations.

**Putting It Together.** The circuit layout isn't critical and any suitable scheme can be followed, but the layout shown for the PC board would be a good one to use. No matter what construction plan is used, PC board or bread board, extra care should be taken when connecting the IC, diodes, and transistors to the circuit. Care should also be taken when connecting the three transformers, so that the low and high impedance windings are not reversed.

The size of the PC board allows the

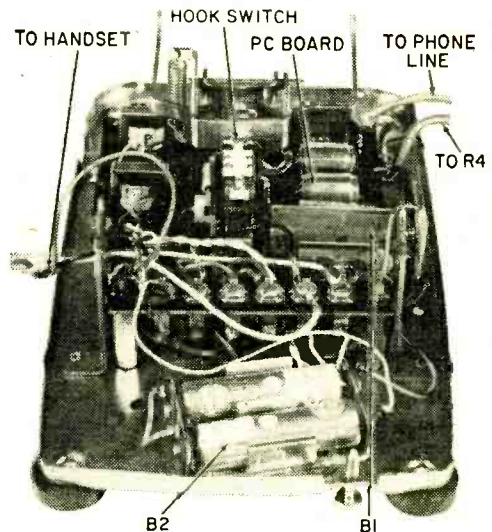

Inside completed Scramble Phone. Surplus phones are available from a number of mail order firms as well as their local stores.

scrambler to be mounted in the base of a standard telephone. All parts located inside the phone, with the exception of the hook switch, can be removed to make the construction job an easy one. Check the pictures when mounting the board and batteries.

In some telephones, the hook switch contains enough switch contacts to function as the three switches, S1A, S1B, and S1C; but if you have one that does not contain enough contacts, a separate switch must be added to switch the battery power. For the scramble phone to automatically bridge the telephone line when the handset is off-hook, at least one section of the hook switch must be used for S1A.

If a dial telephone is selected, the dial  
(Continued on page 118)

# SUPER SCA ADAPTOR

by  
Herbert Friedman

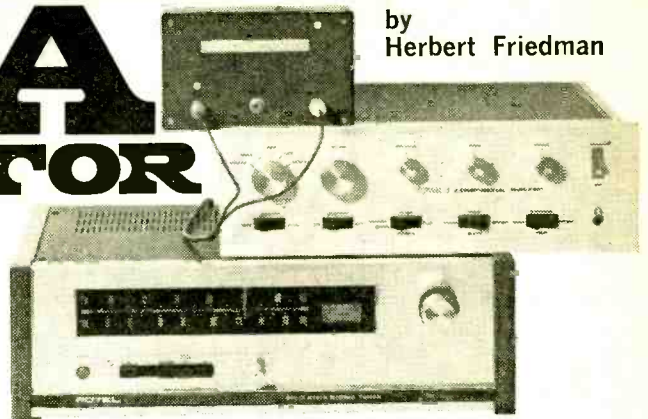

## Hot Enough For DXing

**Y**OU can build a Super SCA detector that's powerful enough for DXing! It's a two-IC circuit in an *amplifier* and *phase locked loop* detector configuration. And it's superior to many other PLL detector circuits because it has an IC amplifier to boost and *lift* the relatively weak 67 kHz sub-carrier signal from the FM signal. That makes it a must for fringe areas.

But let's go back to what SCA is. When a Subsidiary Communication Authorization (known as SCA) is granted to an FM station by the FCC, that station is permitted to transmit a second program *in addition* to its regular program by a special method of modulation. A standard FM radio, even a stereo radio, cannot detect these special broadcasts. The regular listening audience hears only the standard mono or stereo programming. In fact, there is no way of even telling whether or not a station engages in SCA programming. That is, not without a special SCA adaptor that you can build!

If you think you'd like to tune to these hidden broadcasts, we've provided this special project. Special because its high sensitivity permits reception of SCA signals that other low cost adaptors miss.

**What You Can Hear.** For some time now, SCA has been used to transmit educational programs and continuous weather reports to specialized audiences; however, it is *primarily* used for background music—the type heard in restaurants and shopping centers. For example, in the New York City area there are FM stations with SCA programming in light popular music, while others specialize in music of India and Greece.

Best of all, this pleasant, interesting music is never interrupted by an endless barrage of commercials or the patter of an announcer in love with his own voice.

**How it's done.** SCA programming is transmitted by a 67 kHz FM sub-carrier that is impressed on the main FM carrier. When a station broadcasting SCA is received by a standard FM tuner, the SCA sub-carrier is simply wiped out—the listener has no idea it exists. To receive SCA, the FM tuner's output is usually passed through a filter that wipes out everything except the SCA sub-carrier and its modulation. When the sub-carrier is demodulated, the output is only the SCA program; to the SCA listener, the standard programming doesn't exist.

Until recently it took a lot of expensive hardware to receive SCA programs: a very sensitive receiver and a rock-steady detector. (A good receiver is needed because the SCA carrier is only 10% of the total FM signal.) Though many low cost SCA



Adaptor above is teamed with Rotel RT-620 AM/FM tuner and Dynaco SCA-80Q amplifier

# SUPER SCA ADAPTOR

adaptors have been available in project or wired form, most had a tendency to burp, gargle or distort on the very weak signal level of the SCA.

While the radio-astronomy crowd had a great weak-signal detector known as the phase locked loop, it was also true that the astronomical phase lock detector was astronomical in price. But thanks to modern solid-state techniques, the Signetics Corpor-

ation has come up with a phase locked loop detector specifically intended for SCA detection that is priced well under ten dollars.

Available in the standard 8 pin round and 14 pin DIP IC packages, the Signetics SE/NE565 requires virtually no external hardware for SCA detection. Most important, since the phase lock detector automatically locks on the incoming SCA carrier frequency, the Signetics SE/NE565 will demodulate SCA subcarriers of either 65 kHz or 67kHz without adjustment; whichever subcarrier frequency the broadcasting station uses will be received equally

## PARTS LIST FOR SUPER SCA ADAPTOR

- B1,B2—6-volt battery, RCA VSO68 or equiv.  
 C1,C9—470 pF disc capacitor, 15 VDC or better  
 C2—47 or 50 pF disc capacitor, 15 VDC or better  
 C3—0.005 uF disc capacitor, 15 VDC or better  
 C4,C7—0.1 uF disc or Mylar capacitor, 15 VDC  
 C5,C6—100 uF electrolytic, 15 VDC or better  
 C8—7 or 10 pF disc capacitor, 15 VDC or better  
 C10,C11—0.001 uF disc or Mylar, 15 VDC  
 C12,C14—0.02 uF disc, 15 VDC or better (see text)  
 C13,C17—0.05 uF disc or Mylar, 15 VDC or better  
 C15,C16—2000 uF electrolytic capacitor, 15 VDC or better  
 IC1—Integrated circuit amplifier, NE531T (Signetics). Write to Circuit Specialists Co., Box 3047, Scottsdale AZ 85257 for IC prices.  
 IC2—Integrated circuit PLL, NE565A (Signetics)  
 R1,R5,R6—4700-ohms, 1/4-watt resistor, 5%  
 R2,R4—47,000-ohms, 1/4-watt resistor, 5%  
 R3—470-ohm, 1/4-watt resistor, 5%

- R7—1800-ohm, 1/4-watt resistor, 5%  
 R8—5000-ohm potentiometer, PC board mounting  
 R9,R10,R11—1000-ohms, 1/4-watt resistor, 5%  
 SR1 to SR4—Silicon diodes, HEP-154 or equal  
 S1—Toggle or slide switch, SPDT  
 T1—Small filament transformer, 12.6 volt center tapped  
 Misc.—6 x 3 1/2 x 2-in. case, printed circuit material, etchant, RCA phono jacks, push-in clips, hardware, wire, solder, etc.

The printed circuit board for the Super SCA project is available direct from Electronics Hobby Shop, Box 587, Brooklyn NY 11202 for only \$4.95 (includes postage and handling). Canadian shipments add \$2 extra. New York state residents must add sales tax. No foreign orders, please. Postal money orders will speed delivery of Super SCA PC board. Otherwise allow 6-8 weeks for delivery.

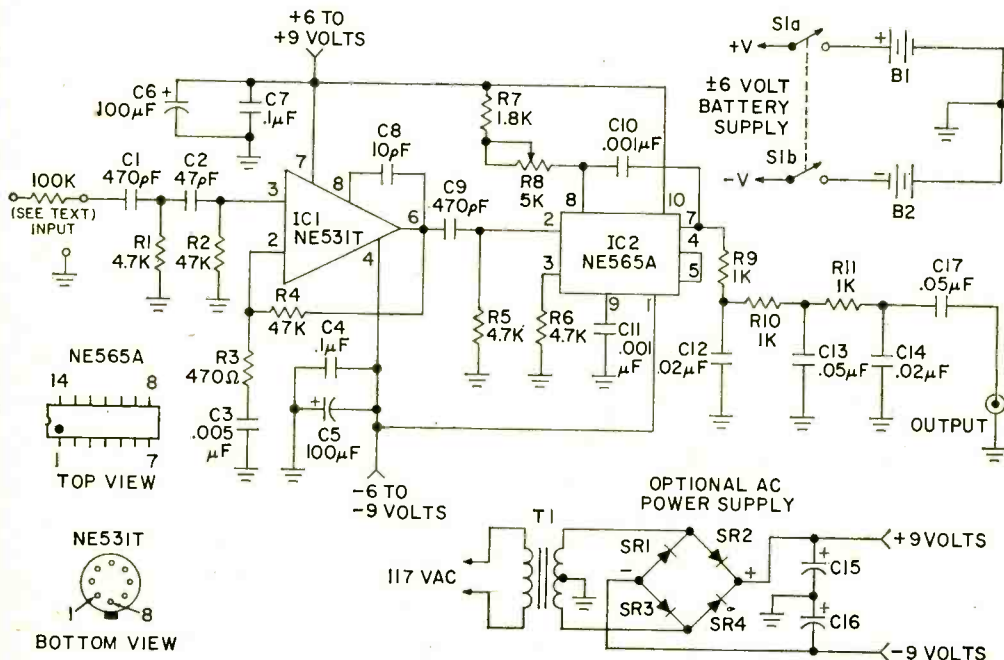



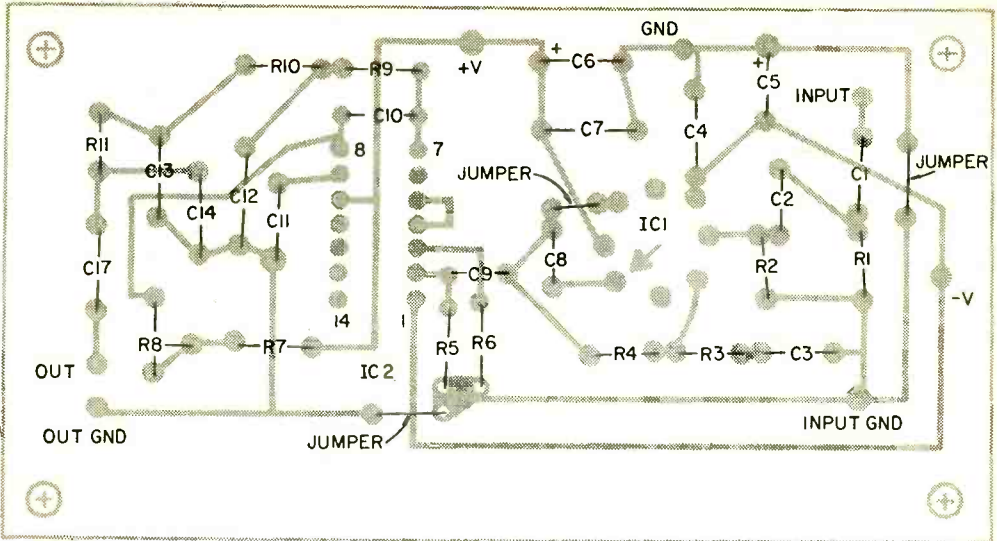

JUMPER WIRES

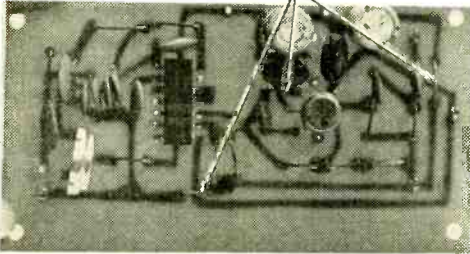

Strong backlighting, left, shows printed circuit wiring through a completed circuit board. Layout above and photo on next page show where to place components.

well with this unit.

**Combination Gets Results.** Unfortunately, the phase lock detector requires at least 80 mV for good reception, and this means that usually only one or two stronger or local SCA stations can be received. To make our SCA adaptor the best there is, we have combined the phase lock detector with a high gain operational amplifier. The result is

a Super SCA Adaptor that can receive SCA programs on a real cheap FM tuner and an indoor rabbit-ear antenna.

Another plus feature for our Super SCA Adaptor is that no large filter coils are needed to suppress the main channel program. Even SCA programming on stereo stations is received cleanly and with no trace of stereo hash. And because large, bulky coils are not needed, the entire adaptor can be assembled on a 2 1/4-in. x 4 1/4-in. printed circuit board for which we provide the template.

Because our adaptor gain is high, it must be assembled on a PC board exactly as

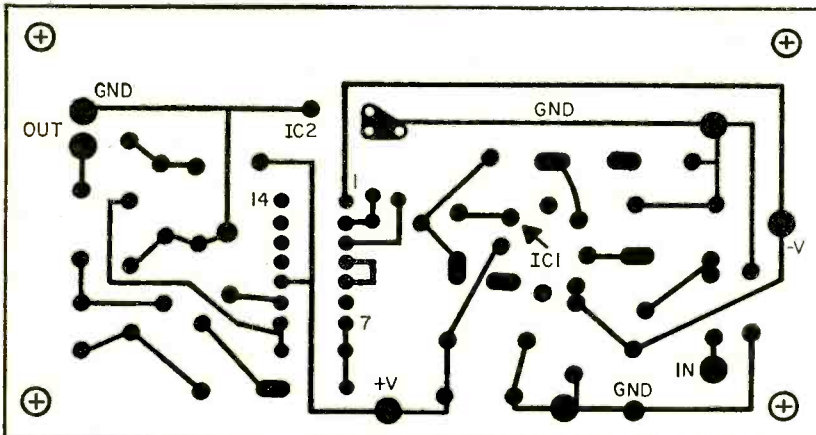

Exact PC board size. Transfer image to copper clad board using carbon paper. This is the bottom (copper) side of your board.

# SUPER SCA ADAPTOR

described to insure complete stability.

**Some Tech Talk.** The signal from your FM tuner's detector before de-emphasis is applied to operational amplifier IC1 through a high pass filter consisting of C1, C2, R1 and R2. The filter's rollover frequency is 60 kHz, which removes a substantial part of the main channel information. Frequency response of the amplifier is tailored by the feedback loop through R3 and C3 to further suppress main channel information. IC1's output is fed through high pass filter C9 and R5 to IC2, the phase lock loop detector. IC2's output is passed through a low pass filter consisting of C12, C13, C14, R9, R10 and R11 which provides de-emphasis and noise suppression. The output level at C15 is about 50 to 100 mV, depending on the signal, and can be fed to your hi-fi or utility amplifier.

Since SCA frequency response is limited to 7 kHz, just about any amplifier can be used.

Note that the adaptor requires a bi-polar power supply in the range of  $\pm 6$  to  $\pm 9$  volts. The power supply can be either batteries or a power line bridge rectifier using a center-tapped 12 volt filament transformer as shown on the schematic. Since the adaptor requires only about 10 mA of current, any small transformer can be used.

**How to Etch a Circuit.** Your first step is to prepare the PC board. Since the board must be precise, we suggest you work directly from the supplied template rather than through an intermediate tracing. Cut a section of any type copper clad board to 2 1/4-in. x 4 1/4-in., clean the copper surface with a strong household cleanser such as Ajax or Comet and place a piece of carbon paper, carbon side towards the copper, on the board. Tape the board under the template and, using a sharply pointed tool such as a scribe, indent the copper foil at each component mounting hole by pressing the point of the tool through the template into the foil. (Each indent will serve to mark the hole's location when the board is drilled.) Using a ball point pen and firm pressure, trace the outline of the foil areas.

**Continue.** . . . Remove the board from under the template, discard the carbon paper and, using a resist pen such as the Kepro RMP-700, available from Allied Radio, fill in the foil areas with resist. Note that some of the IC1 and IC2 pins are not used, though they must pass through the board. Place a drop of resist over the indents so you'll know where to drill after the unwanted copper is etched away. Similarly, mark the indents at the corner mounting hole locations. Make certain you mark IC1 terminal number 8; you can use a drop of resist.

Immerse the PC board under at least 1/4-in. of etchant for about 45 minutes and then inspect the board. If all the unwanted

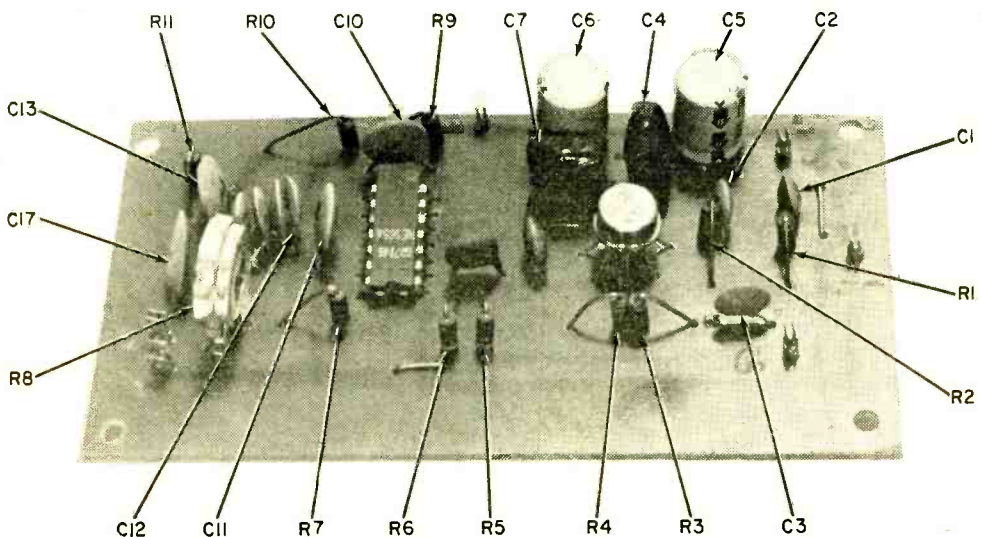

Completed circuit board. Resistor R8 easily adjusts frequency of PLL to 67 kHz.

copper has not been etched away, re-immerses the board in five minute intervals until all the copper not protected by resist has been removed. Then rinse the board under running water and remove the resist by scrubbing briskly with a steel wool pad such as Brillo.

Using a #56 drill bit, drill the holes for the connecting terminals (push-in terminals) and trimmer potentiometer R8. Drill the corner mounting holes to clear a #4 or #6 screw and drill the remaining component holes with a #58, #59 or #60 bit.

**You Can Buy the Board.** You don't have to make a printed circuit board for the Super SCA—you can buy one. The Electronics Hobby Shop is offering the PC board completely etched ready for drilling and assembly. This beats trying to copy the author's board layout exactly, and the mess and expense of etching copper.

**Mount the Components.** Install IC1 and IC2 before any other components. Note that the IC1 lead opposite the case tab is number 8. Insert the leads (begin with number 8) and push IC1 toward the board until there is about  $\frac{3}{8}$ -in. between IC1 and the board. Solder the wires and cut off the excess.

Hold the PC board so you are looking at the top with IC1 to the left. Hold IC2 so the notch is away from you and insert IC2's leads into the matching holes. *Doublecheck the notch before soldering.* It is correct if the distance from the notch to the edge of the PC board is greater than that of the unnotched end to the opposite edge of the PC board. If all is okay, solder IC2.

Install trimmer potentiometer R8 and solder. Make certain you use sufficient soldering heat to flow solder to R8's terminals.

Then install the three wire jumpers and, finally, the remaining components taking extreme care that the polarity of capacitors C5 and C6 is correct. Note that C5 has the positive lead connected to ground.

While capacitors C12 and C14 are indicated as 0.02  $\mu$ F, they are not the easiest to obtain in miniature size. You can substitute two parallel-connected 0.01  $\mu$ F capacitors. Simply twist their leads together and insert them into the matching holes. Do not tin the twisted leads prior to soldering as they will not fit into the holes if tinned.

**Set-up and Checkout.** Either a bi-polar battery power source or a standard bi-polar power supply can be used. Since there is

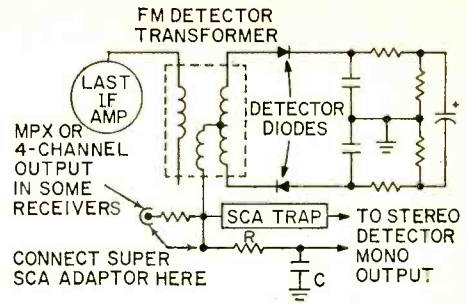

**Always connect SCA adaptor before de-emphasis network R, C as shown above. Most tuners, receivers do have an MPX jack for a home SCA, or 4-channel use.**

essentially no difference in performance between a  $\pm 6$  V and  $\pm 9$  V power supply, use whatever you have available. For long-term battery life we suggest Burgess type Z4 6 volt batteries (or their equivalent).

The Super SCA adaptor connects to your mono FM tuner or receiver detector *before* the de-emphasis. If you connect after the de-emphasis network, you will find the 67 kHz subcarrier has been filtered from the signal, so you will get nothing but noise from the adaptor. The figure shows a typical FM detector output, the de-emphasis network and the correct connecting point for the adaptor. Since it is possible the adaptor might load down the detector for normal FM reception, we suggest a switch be installed, so the adaptor can be removed from the circuit for normal FM listening.

The adaptor is most conveniently connected through a phono jack installed in the tuner's rear apron, though you can use a direct wire connection.

Note that if you have one of the older mono FM tuners with an "MPX output" you already have the correct connection as the MPX output is the non de-emphasized detector output. Similarly, if you have a modern FM Stereo tuner with a "4-channel decoder" or a "quadrasound decoder" output you also have the correct connection; they are also non de-emphasized detector outputs.

Connect the tuner's detector output to the adaptor with the shortest possible length of shielded cable or ordinary zip cord, or install the adaptor directly in the receiver if there is sufficient room. Connect the adaptor's output to any high gain amplifier; for example, the microphone input of your hi-fi amplifier, or a utility amplifier is fine, or maybe an old tape recorder. (See page 100)



# SUPER SCA ADAPTOR

**R8 Locks Loop.** Tune in a station you know is transmitting an SCA program (a call to your local station should get you the info.) and adjust trimmer potentiometer R8 for best sound quality. Normally, the reception will be almost completely garbled, then fade into a clean signal as R8 is adjusted, then fade into garbling again as R8 is further adjusted. Set R8's wiper so it is approximately midway between the two points of garbled sound. Usually, the best sound will occupy a broad part of the R8 adjustment range, so don't try to be too fussy.

If you don't know which station(s) are transmitting SCA, set R8 to the mid position and tune every station very carefully and slowly. When you hear anything that sounds like distorted music, try adjusting R8; if it is real SCA, it will turn *clean* as R8 is adjusted. Some stereo stations might cause sound bursts that you think are SCA.

If adjusting R8 doesn't bring in a clean signal, it's not SCA. Note that once R8 is adjusted there is no stereo hash interference on SCA signals. Hash will only be heard from non SCA signals.

**Problems?** The high sensitivity of this system may require desensitizing procedures; in the event you cannot receive *any* SCA stations, you either have none in your area or you have made a construction error. If the non-SCA program from the tuned-in station is heard breaking through the SCA programming, follow the suggestions in our troubleshooting box. If your adaptor doesn't work at all, beg, borrow or steal an oscilloscope and check input and output waveforms as shown in the scope photos. Just be sure to return the scope so we don't get in trouble with John Law for inciting a felony!

**What's Your Beef?** Here are some hints to help you steer clear of trouble—straight toward your musical enjoyment and SCA DXing!

☞ *If your problem is a weak signal re-*  
(Continued on page 117)

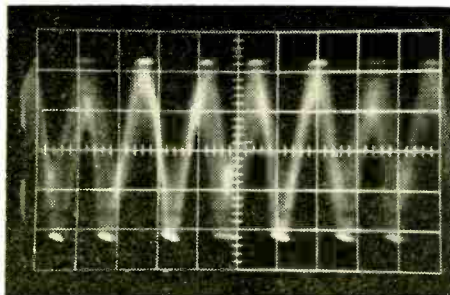

A

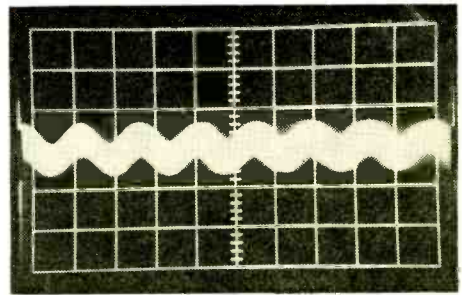

B

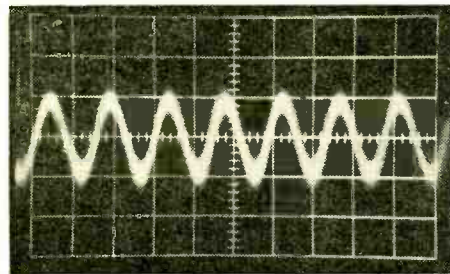

C

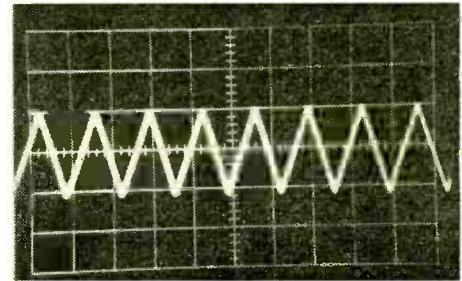

D

Oscilloscope patterns quickly locate any possible difficulty. You can use a general purpose scope since the signals are under 100 kHz. With "triggered" scopes, set the time base to 10  $\mu$  sec/cm. Photos B and C are input and output of IC1, the 67 kHz amplifier. If signal is clipped as in A, main channel program may break through—see text for cures. Normal IC2 pin 9 waveform at D. Vert. sens: B, 20mV/cm; C, 1V/cm.

# VISULERT

## ADD A FLASHING LIGHT TO YOUR TELEPHONE BELL

by Robert S. Kelland

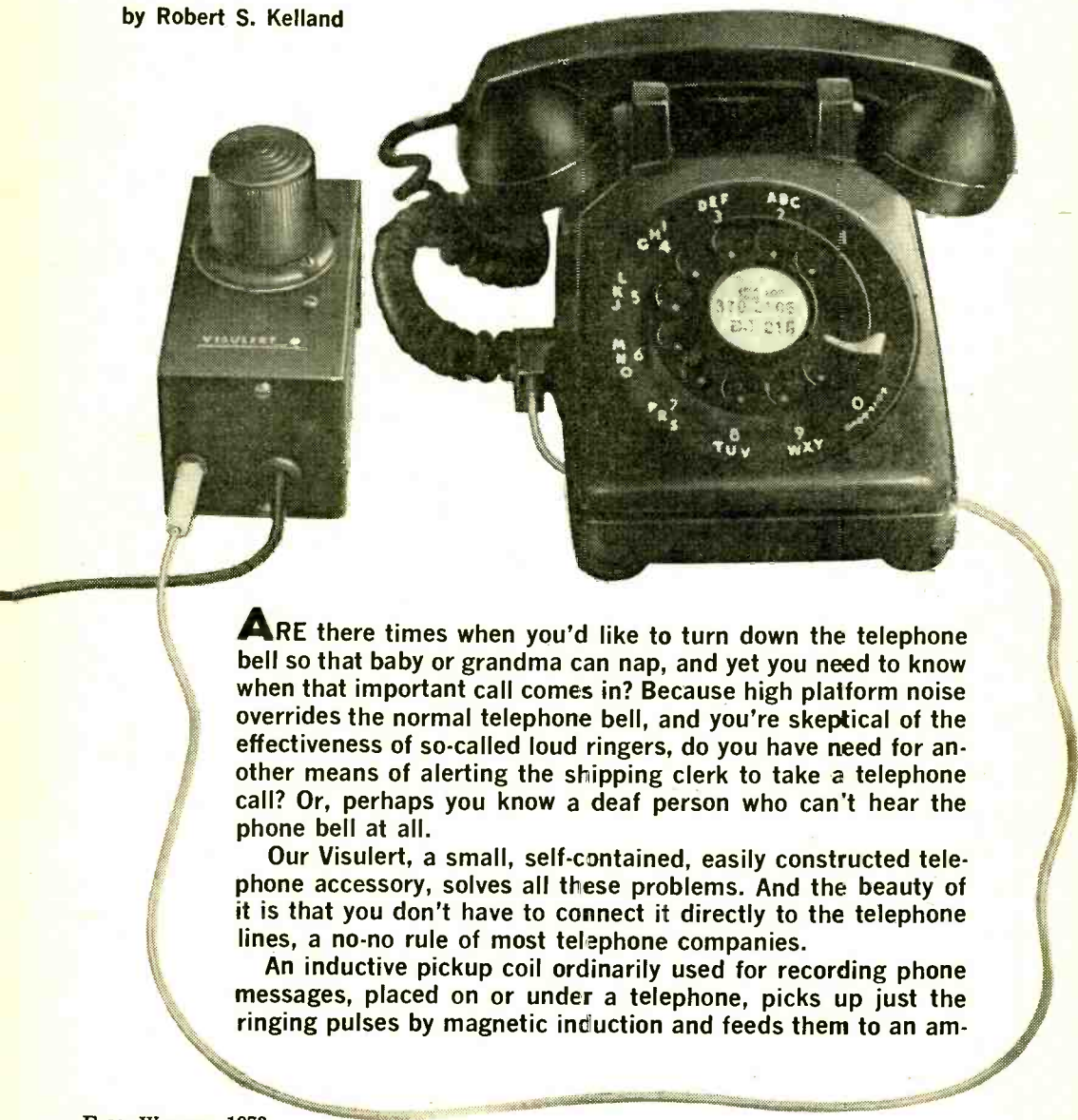

**A**RE there times when you'd like to turn down the telephone bell so that baby or grandma can nap, and yet you need to know when that important call comes in? Because high platform noise overrides the normal telephone bell, and you're skeptical of the effectiveness of so-called loud ringers, do you have need for another means of alerting the shipping clerk to take a telephone call? Or, perhaps you know a deaf person who can't hear the phone bell at all.

Our Visulert, a small, self-contained, easily constructed telephone accessory, solves all these problems. And the beauty of it is that you don't have to connect it directly to the telephone lines, a no-no rule of most telephone companies.

An inductive pickup coil ordinarily used for recording phone messages, placed on or under a telephone, picks up just the ringing pulses by magnetic induction and feeds them to an am-



# VISULERT

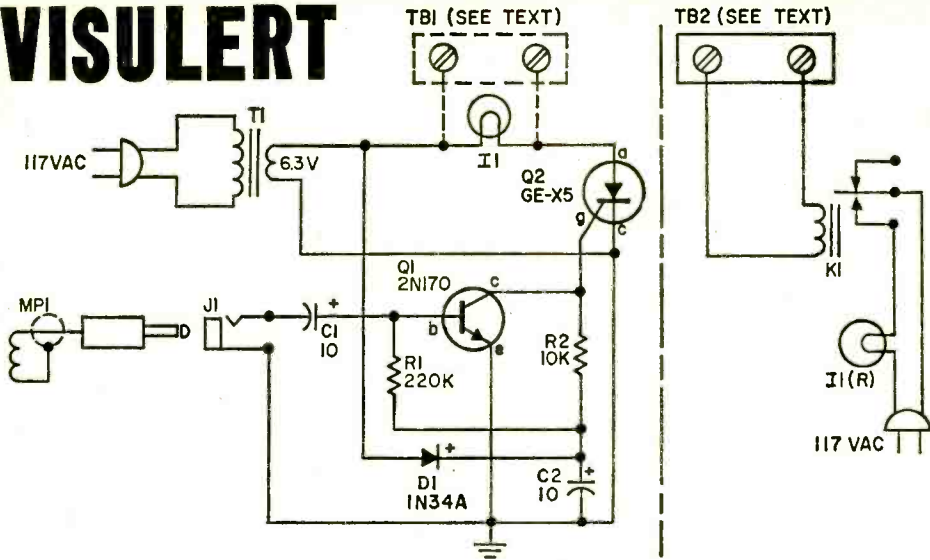

## PARTS LIST FOR VISULERT

- C1, C2—10- $\mu$ F, 35-VDC miniature electrolytic capacitor (Radio Shack 272-1025 or equiv.)  
 D1—75-PIV, 50-mA silicon diode, type 1N34A  
 I1—Panel-mounting pilot lamp assembly with clear plastic dome lens (Lafayette 99E63406 for miniature bayonet base lamp 32E66194 or equiv.) (note: our model was adorned with the addition of a large plastic lens salvaged from a toy fire engine)  
 J1—Miniature phone jack (Lafayette 99E63141 or equiv.—includes matching plug)  
 MPI—Inductive pickup coil assembly (Radio Shack 44-533 or equiv.)  
 Q1—GE 2N170 npn germanium transistor  
 Q2—GE X5 silicon-controlled rectifier  
 R1—220,000-ohm, 1/2-watt resistor  
 R2—10,000-ohm, 1/2-watt resistor  
 T1—Filament transformer; primary 117 V, 50-60 Hz; secondary 6.3 V at 1.2 A (Radio Shack 273-050 or equiv.)  
 1—4 x 2 1/4 x 2 1/4-in. aluminum minibox (Lafayette 12E83704 or equiv.)

- 1—AC power cord (Lafayette 12E39011 or equiv.)  
 1—2 point + ground lug tie strip (Lafayette 32E12073 or equiv.)  
 1—5 point + ground lug tie strip (Lafayette 32E12131 or equiv.)  
 Misc.—Hookup wire, solder, hardware, spray paint or pressure-sensitive vinyl sheet (Contac or equiv.), grommets, etc.  
 If remote lamp is used add following:  
 I1(R)—50 to 250W, 117V lamp bulb in porcelain Edison base lamp socket, 3/4-in. diameter base (Lafayette 13E1359 or equiv.—mount on outer surface of junction box or cover panel of suitable box used)  
 K1—Spdt miniature ruggidized remote control relay (Lafayette 99E60915 or equiv.—mount on inner surface of box cover panel)  
 1—Pane for box (Lafayette 19E37010 or equiv.)  
 1—6 1/4 x 5 1/4 x 2 1/4-in. Bakelite Box (Lafayette 19E20016 or equiv.)  
 2—2-contact screw terminal strip (Lafayette 32E644488 or equiv.) (TB1, TB2)

plifier in the Visulert. This amplifier triggers an SCR that switches a lamp *on* and *off* in step with the pulsing of the ringing signal.

**How It Works.** Provided magnetic pickup MPI is properly located within the ringer's magnetic field an electrical voltage is induced in the coil of MPI whenever the ringer of a telephone is energized. This voltage is fed via jack J1 to the base of transistor Q1. The resulting amplified signal output on the collector of Q1 is coupled to the gate of silicon controlled rectifier Q2 and triggers it *on* whenever the signal appears on its gate. Lamp I1 is turned *on*

each time Q2 is triggered *on* and remains *on* until Q2 is triggered *off* by a drop in the induced signal level. Since the ringer voltage is pulsating, the Visulert will flash its lamp *on* and *off*, following the ringer pulses.

**Building Visulert.** Our model is housed in a standard 4 x 2 1/4 x 2 1/4-in. aluminum minibox. Though the layout isn't critical, you will speed up your construction time by following our layout as shown in our photos.

All of the components are mounted either directly on the minibox or to tie strips, which  
 (Continued on page 114)



# ***BUILD IT FAST..***

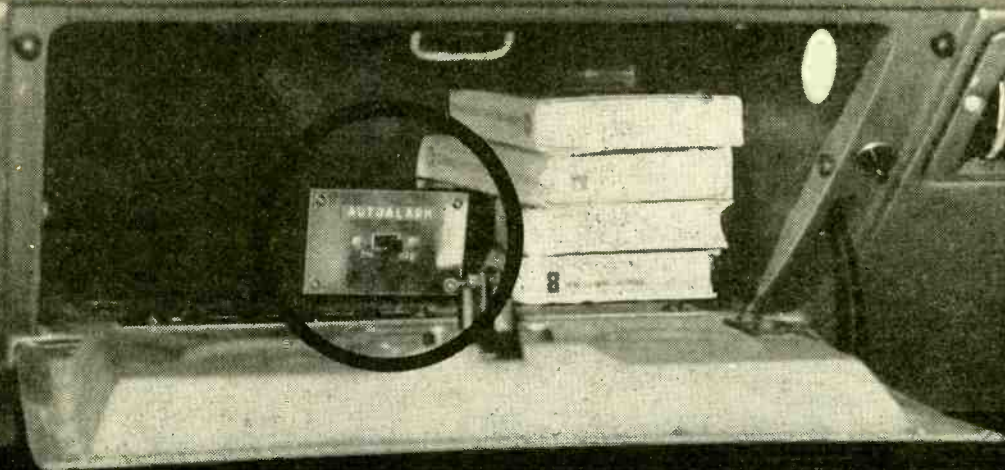

## ***AUTO ALARM FOR YOUR CAR TAPE PLAYER***

by Herbert Friedman

**T**he police estimate that in a large city such as New York the life expectancy of an unattended Corvette is about 10 minutes—after that it has a new "owner." The life expectancy of a mobile cassette or 8-track tape player is about 24 hours, for they are really hot resale items.

Actually, most of the fancy tape player lock-alarms are useless—they are too obvious, too easily bypassed, and are often stolen along with the tape player! Our AutoAlarm sounds a car's horn continuously if anyone removes the tape player. And once triggered, the horn can be turned off only by the AutoAlarm's switch.

All it takes is a few dollars worth of experimenter's components to throw together an AutoAlarm that will give you just about as much protection as you can get because it doesn't look like an alarm. Tucked away in the glove compartment or under the seat, a single wire runs to the tape player's case—a wire that looks as if it's an ordinary ground wire.

The entire AutoAlarm is assembled directly on the back of a SPST slide switch. The assembly can then be installed in any small metal or plastic cabinet. Silicon Controlled Rectifier SCR1 can be just about any type rated at 25 PIV (peak inverse volts), 5-Amps

(Continued on next page)

# AUTO ALARM

or higher, such as the HEP-R1220.

To identify the SCR leads, lay it flat on the table so the side with the metal rim (around the mounting hole) faces up; the side *without* a rim should be against the table. The SCR leads will now conform to the layout shown.

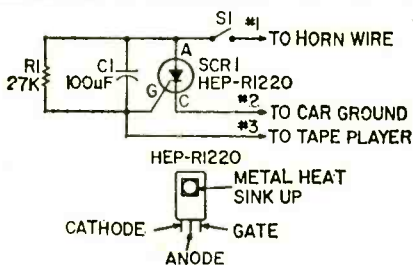

This simple circuit can be wired quickly. Switch S1 is closed for normal operation.

## PARTS LIST FOR MOBILE TAPE AUTO ALARM

- C1—100 uF electrolytic capacitor 15 VDC or better
- R1—27,000-ohms, 1/2-watt resistor
- SCR1—HEP-R1220 or equiv (see text)
- S1—SPST slide switch (alarm off)
- Misc.—Metal or plastic cabinet, wire, hardware, solder etc.

No wiring precautions are necessary other than to doublecheck that the C1 polarity is correct; its positive terminal connects to SCR1's anode (A) terminal.

The other figure shows how to connect the AutoAlarm. Note that AutoAlarm wire #2, from SCR1's cathode, must connect to the car body (ground) while the #3 wire also connects to ground *but* through the tape player's case. Wire #1 connects to the horn control wire which generally enters at the bottom of the steering column (sometimes in the engine compartment, sometimes under the dash).

**How It Works.** There is a positive voltage from the car battery across a horn button when it is open. By closing the horn button, the circuit is completed and the horn will sound. This positive voltage is applied to SCR 1's anode. The SCR's gate is grounded through the tape player's case, so the SCR is normally off. When the tape player is removed from its mount, the auto-alarm's #3 wire is disconnected from

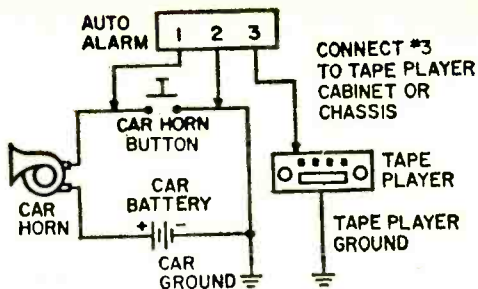

Intermediate solenoid found on most autos in place of horn in our simple diagram does not alter operation. Connect #1 to button. Remember, the curved side of electrolytic capacitor symbols, such as C1, represents the terminal that must be connected to the negative voltage (with respect to the plus capacitor connection). In this circuit, it means the negative terminal of capacitor C1 must be connected to the gate terminal of Silicon Control Rectifier SCR1 at left.

ground. The SCR gate is no longer grounded, so current can flow through R1 to the gate. The SCR turns on, effectively shorting its anode to its cathode. This means the horn control wire is now grounded, so the horn will sound.

Once the horn is sounded it can only be turned off by opening switch SW1.

To make it easy for the thief to trigger the AutoAlarm we suggest that the #3 wire be 22 or 24 gauge stranded—thin enough to be easily broken when the player is removed. The #1 and #2 wires should be 18 gauge stranded.

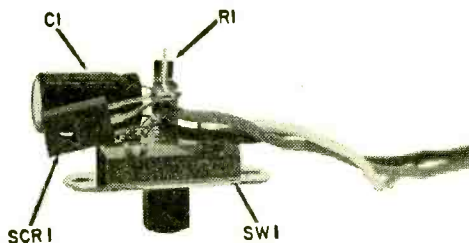

Here you can see just why we say, "Build it fast." And a simple three point installation means you install it fast, too! Count 'em, just four components and some wire make up this protective device that can save you a lot of grief over a lost, expensive player.

So the next time you park your wheels in a rough place, lock the car and take the keys with you. You can't expect to protect your tape player when the whole car is heisted!



# How many more opportunities can you afford to miss in the next 9 months?

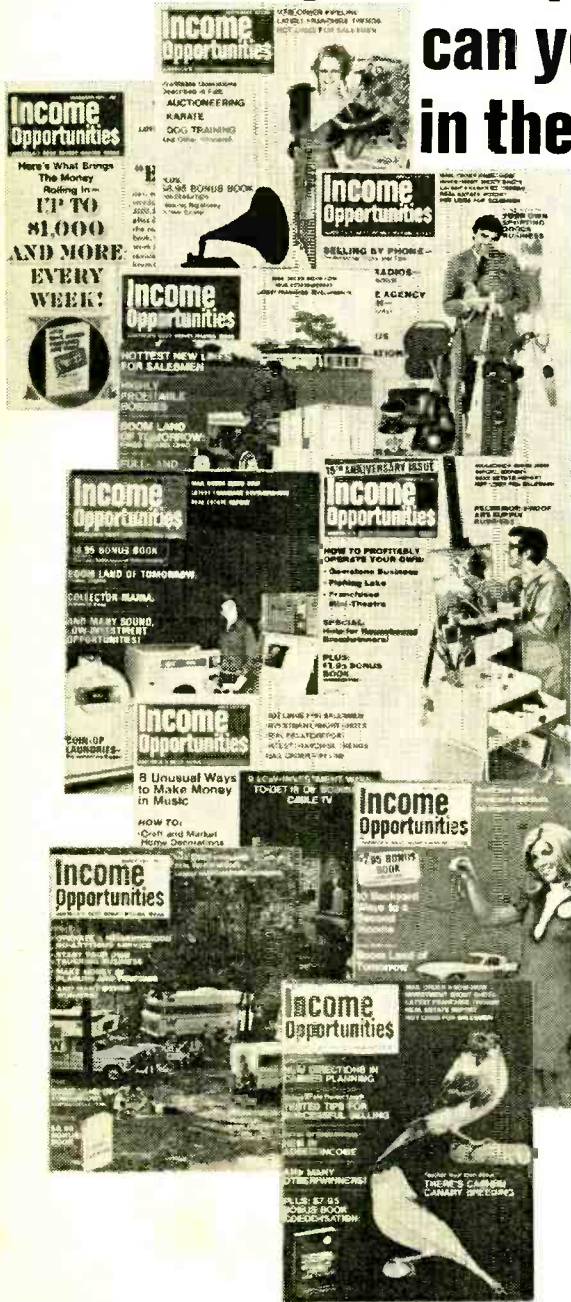

Now, you can discover for yourself the amazing variety of money-making opportunities *that are still yours for the taking... if you know where to look to find them!* For more than 15 years, *Income Opportunities* has shown thousands of people the newest, proved ways for cashing in on hobbies, sidelines, and the coming trends in consumer-buying habits. For that extra income each month—in your spare time—or full time, here is where you'll find these opportunities for *personal or business gain.*

See the independent business opportunities for a second income... the franchise opportunities still open in many fields today (with more coming!)... the profits in a service business you can start at home... the hot lines for salesmen, reports on winners in real estate, tips on investments.

*Income Opportunities* is the country's leading magazine of money-making ideas. It brings you unusual ways to make money in such fields as music and auctioneering—even in karate and dog training. And you'll *learn the professional techniques* of others who are making it big in mail order and selling by telephone—how to start, how to operate profitably!

You'll find a wealth of opportunities in *Income Opportunities* during the next 9 months that can get you started now toward that second income or your own independent business. Can you afford to miss them?

## SAVE WITH THIS INTRODUCTORY OFFER

9 OPPORTUNITY-PACKED  
**MONTHS ONLY \$2.98**

- Enter my trial subscription for 9 months for \$2.98.  
I save \$2.77 off the regular subscription price!  
I save \$3.77 off the newsstand price!
- I prefer 12 months for \$3.98. I save \$5.27 off the single copy price!
- Please bill me.
- Payment enclosed

name \_\_\_\_\_  
(please print)  
address \_\_\_\_\_  
city \_\_\_\_\_ state \_\_\_\_\_ zip \_\_\_\_\_

**INCOME OPPORTUNITIES**  
MAIL COUPON P.O. Box 2600  
TODAY TO: Greenwich, Connecticut 06830  
B918



# Diaper Snooper

It's time for a change

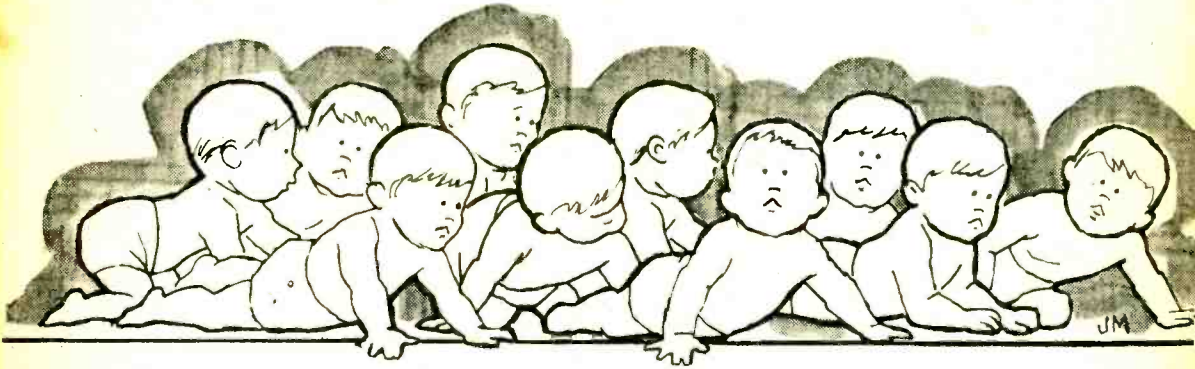

by James E. Lockridge

**I**T'S POKER NIGHT. The boys are at your house. You've just drawn your fourth King and, while your wife is playing bridge at the neighbors, you put on your best poker face to get ready for the kill.

Then the phone rings just as Junior starts screaming. The phone can wait, but what about Junior? If it's a wet diaper it can wait two or three minutes; Junior's done it before and besides, you can get him something nice with what four Kings can draw. What'll it be, Junior, the phone or four Kings?

Well, perhaps the problem would be simpler if Junior were equipped with a little gadget we call a Diaper Snooper. It's a remote radio moisture alarm that's fun, useful, and easy to build. It senses moisture and produces a tone on any FM radio tuned to its transmitting frequency. Or, if you want to indicate a remote occurrence, a minor *circuitectomy* turns the unit into a switch operated, remote radio alarm and reduces the already rock bottom cost of components. It is completely silent in operation and produces no electrical hazards such as shock, sparks, or heat build up. No relay is used, which contributes to keeping size and cost to a minimum, and it uses a very inexpensive FM transmitting module.

**The Pink Pampers.** Originally, this gadget was designed for use in baby's diapers. It's an excellent device for alerting a parent to wet diapers as soon as possible to prevent

diaper rash. It would be useful in initial potty training, in training older children with bed wetting problems, or with geriatric patients. One major advantage of its use with children or sick people is that the alarm is actually heard over the radio in another room.

The transmitter, limited in radiation to comply with FCC standards, will broadcast loud and clear about 300 feet. The more powerful the receiver, the longer the range and the louder the signal. By varying resistor R1 slightly from unit to unit, a different identifying tone would tell which one of a multi-unit installation was transmitting. Try changing R1 in 20 per cent steps; an increase will lower the tone.

**Inside Story.** The circuit is composed of four simple circuits working together. They are a DC amplifier, a UJT (unijunction transistor) relaxation oscillator, a voltage divider, and an FM transmitter module. A 9-volt battery was chosen because of its availability and compactness. The entire unit can easily be constructed in a space no larger than the battery, with the finished unit plus battery in a plastic box about the size of two batteries.

The first simple circuit is the moisture detector-DC amplifier. The moisture detector plate (WP1) is simply two conducting plates held close together, but not touching. You can buy the detector for a buck from a source noted in the Parts List or make one

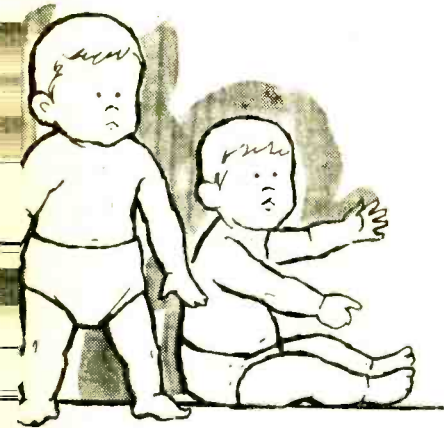

from a small (1-in. x 3/4-in.) piece of unused printed circuit board. Simply etch, cut or file a 1/32-in. groove down the middle of the plated side and connect a lead to each half.

When wet, some current is passed across the insulation and is amplified by Q2 and Q3. Resistor R6 protects Q2 and provides for better differentiation between wet and dry. When Q3 is forward biased by Q2, current is passed to two other simple circuits: the UJT relaxation oscillator and voltage divider. (The voltage divider provides the lower voltage required by the FM transmitter module.)

The heart of the oscillator is Q1, a unijunction transistor. An RC network consisting of R1 and C1 determines the audio frequency to be heard over the FM receiver. This frequency can be so low that separate, individual clicks are heard or it can be as high as you desire. Values given provide a pleasing "warning horn" tone. The output of this oscillator feeds through

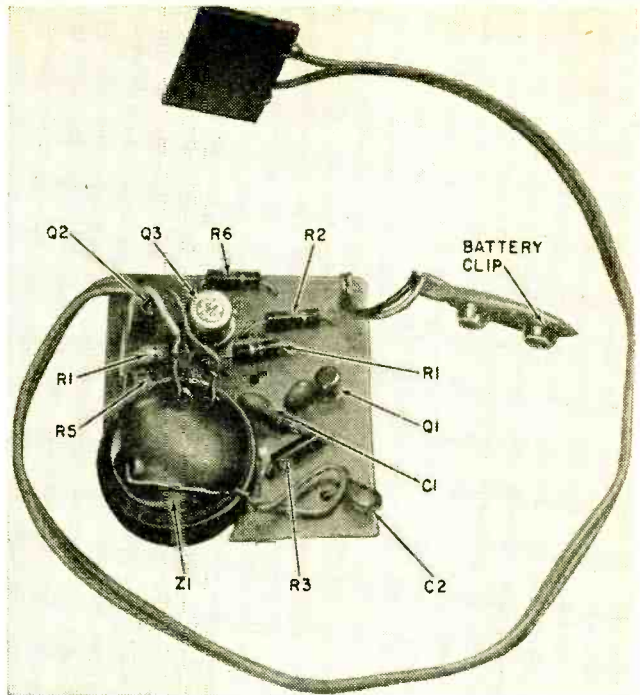

Junior, upper left, points to completed snooper before installation in plastic case, below. FM module is seen in lower left of circuit board.

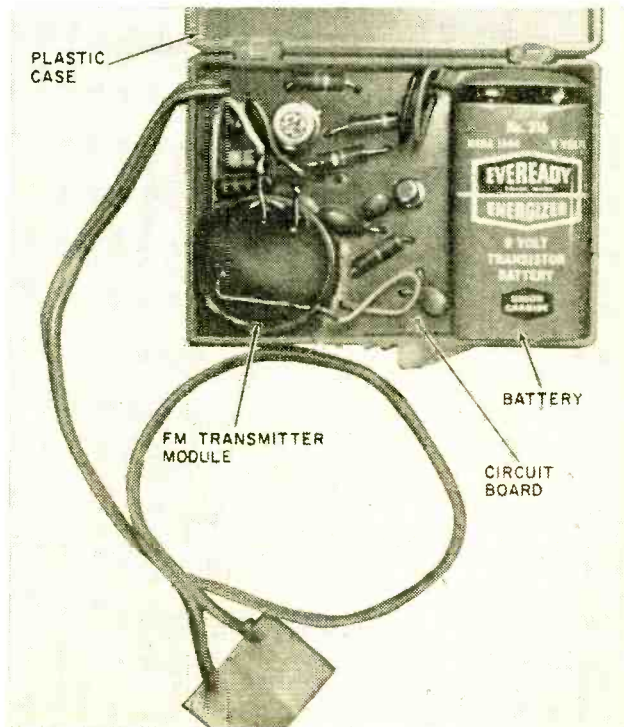



# DIAPER SNOOPER

C2 to the audio input (mike input) of a small FM transmitter module.

**Low Cost FM.** Let's go back to the front of the oscillator circuit now and pick up where the voltage divider circuit taps off. This circuit steps down the 9-volt battery voltage to the 1½-volts required by the FM module.

The FM wireless mike transmitter module is an amazing little gem available at the remarkably low price of \$2.98. Its performance is commendable, even for transmitting music. In our application, fidelity isn't important, but the potential is there. The module is a small, thick black plastic package with four wires protruding from one side. The wires are: the antenna (no connections here), the audio input (from the oscillator circuit), the power input (from the voltage divider circuit), and the common ground. The module transmits on an FM frequency around 95 MHz. but the frequency can be adjusted by changing the length of the short antenna wire or by placing a coin behind

the module opposite the side the wires are on; instructions are included with the module. In use, consideration should be given to the fact that the capacitance of a thumb or hand on this side of the module will change the transmitting frequency slightly.

The 9-volt transistor radio battery lasts for many weeks if WP1 is wetted only occasionally. What leakage exists across Q3 with WP1 dry doesn't appear to affect battery life much. As battery life deteriorates after several weeks, simply turn the volume up on the receiver.

The *circuitectomy* referred to earlier for converting the unit to a switch operated remote radio alarm simply requires the replacement of the DC amplifier portion of the circuit (R6, WP1, Q2, Q3) with a switch of your choice: mercury, push-button, any kind will do; it depends on your application, needs, and imagination.

**Catch 88-108.** A good example of a potential application for the modified circuit would be a situation in which the writer found himself while stationed overseas. I was exasperated by the neighborhood hood-

(Continued on page 114)

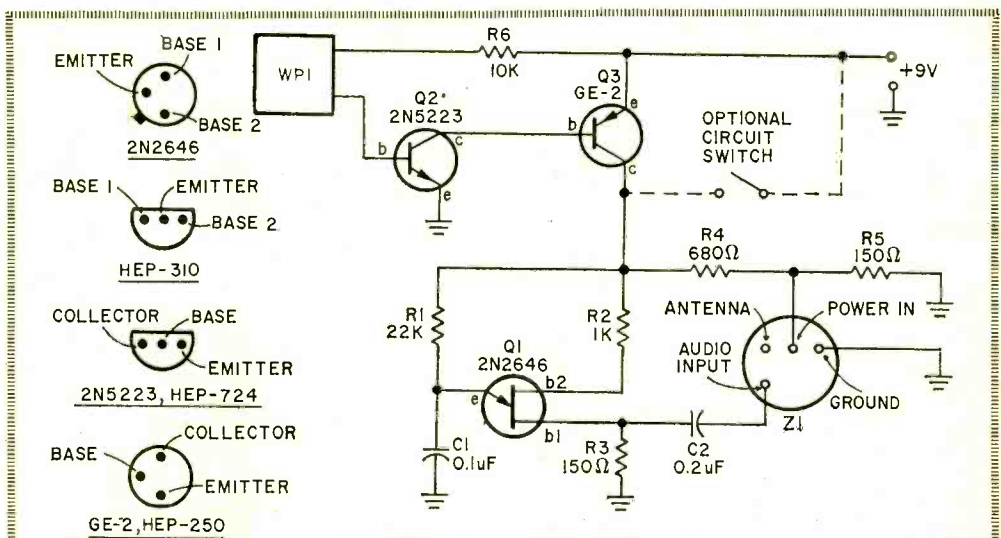

## PARTS LIST FOR DIAPER SNOOPER

- C1—0.1 uF, 12-VDC disc capacitor.
- C2—0.2 uF, 12-VDC disc capacitor.
- Z1—FM Wireless Microphone Transmitter Module (Lafayette Radio Cat. #19-55277, \$2.98)
- WP1—Moisture detector plate, see text (Science Fair Electronics, 2615 W. Seventh St., Ft. Worth, Texas 76107, \$1.00 each)
- Q1—Unijunction transistor, 2N2646, HEP-310 or equiv.
- Q2—NPN transistor, 2N5223, HEP-724 or equiv.

- Q3—PNP transistor, GE-2, HEP-250 or equiv.
- R1—22,000-ohm, ½-watt resistor, 10%
- R2—1,000-ohm, ½-watt resistor, 10%
- R3—150-ohm, ½-watt resistor, 10%
- R4—680-ohm, ½-watt resistor, 10%
- R5—150-ohm, ½-watt resistor, 10%
- R6—10,000-ohm, ½-watt resistor, 10%

Misc.—Perforated board, wire, solder, small plastic box (2x2½x1-in.), etc.

## New Products

*Continued from page 16*

tomobile travelers is now available. Auto Distress Flags utilize four visual signs to indicate the type of aid needed: out of gas, flat tire, mechanical failure, or injury. Red, white, and blue colors are used to achieve maximum visibility, and each plastic flag measures 16-in. x 24-in. All flags are backed with a strip of self-adhesive tape for convenient mounting on rear window or bumper areas. Flags fold flat and compact for handy storage in glove compartment, console, or trunk. Great for travelling CBers—never can tell when the battery will go! Sets of four flags are available at \$1.25 per set, postpaid, from Aladdin's Safety Leisure Products/A Div. of Aladdin's Bazaar, 4811 S.W. 44th Avenue, Ft. Lauderdale, Florida 33314. Satisfaction guaranteed.

### Telephone Answering

The Phone Butler, a telephone answering device and home message center, with a suggested retail price of \$99.95 has been introduced by Metrotec Electronics, Inc. a subsidiary of BSR (USA) Ltd. It is shipped with a professionally pre-recorded answering mes-



sage for an authoritative, attention-commanding sound, and to aid microphone-shy users. But there is also provision for home recording of personal messages with a built-in condenser microphone. All functions are activated by pushbuttons for simple and fool-proof operation. The Phone Butler can record up to 30 messages on a special cassette, and a "Message Waiting" indicator light is illuminated whenever a call has been taped. The Phone Butler is factory set to answer after as many as five rings for use while someone is at home, but unable to answer the phone promptly every time. For more information, circle No. 40 on Reader Service Coupon.

### Powerful Hippo

"Powerful enough to brag about." That's how Avanti describes its new 5-foot Hippo mobile antenna. Base loaded, with tunable tip to allow adjustment for the lowest possible VSWR,

the Hippo 5 (Model AV-325) will handle 500 watts. The new antenna features "Hermicoil", a tough ABS molded covering that hermetically moisture-proofs the coil to keep down noise and keep performance up. The Hippo 5 has its own snap mount and needs no additional mounting hardware. It is priced complete at only \$29.95. For more information on the Hippo 5, circle No. 38 on Reader Service Coupon.



### Temp Sensor

What's the temperature outside? In the garage? In the freezer? It's easy to find out by pressing one of three buttons. Olsen's deluxe Multi-Probe Electronic Thermometer F-201 is useful for other purposes, for exam-

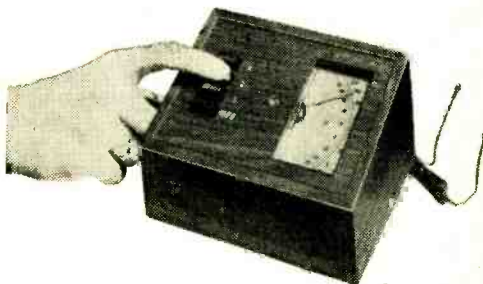

ple: darkroom, aquarium, hot-house, scientific use and many others. Three sensor probes on 15-foot cords offer accuracies of  $\frac{1}{4}$ -degree. Distances can be extended up to 1000 feet with ordinary lamp extension cord. And the price is right—\$49.95. For further information and the Olsen catalog, circle No. 29 on Reader Service page.

### Tune in FM and TV Audio

The new "Eavesdropper" radio from Midland International receives standard VHF televi-

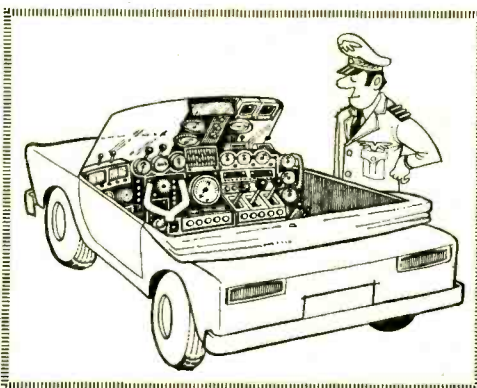



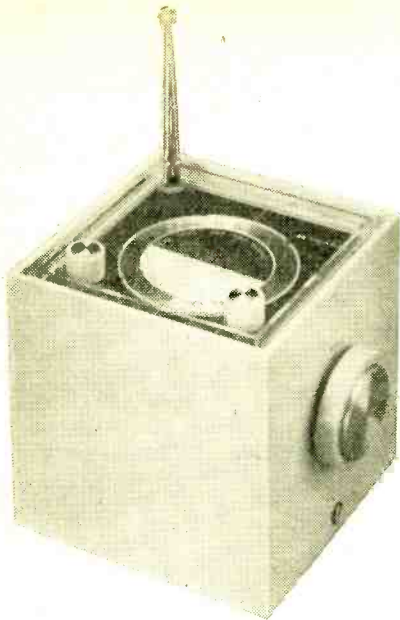

sion audio as well as FM broadcasts. Battery-powered, the compact radio permits the listener to enjoy the audio portion of TV shows. Radio is equipped with jack for earphone or pillow speaker—can be used with television video for private listening in bed, etc., without disturbing others. Features include a superheterodyne receiver, RF amplifier. Includes 4 "C" batteries and earphone. Suggested retail price for model 11-707

is \$29.95. For more information, circle No. 39 on Reader Service Page.

### Fix CB

Even if you don't know anything about electronics, you can learn how to repair CB radios if you study this course and can master the use of hand tools. Lessons, which can be learned in two hours or less, are mailed to you weekly. And, they're easy to study because they employ the step-by-step programmed-instruction technique! Before you start learning about CB radio circuits, you learn about the fundamentals of electronics as explained in simple easy-to-understand language—without pain and without having to know math except simple arithmetic and the most basic algebra. For more information from CB Radio Repair Course, Inc., circle No. 41 on Reader Service page. ■



*"He's been broadcasting 'Mayday' on that thing for three days. This morning he found out that it's a cassette recorder!"*

## U-Pick-It

*Continued from page 42*

button ON-OFF switch that we picked up in the electrical supply section of the local

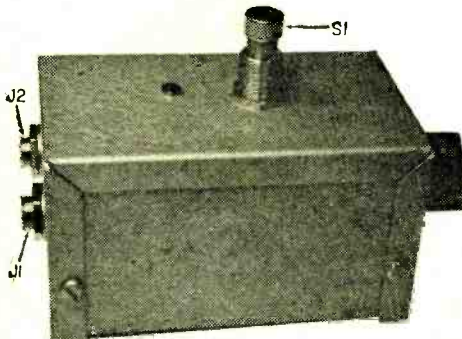

**Author's U-Pick-It has input, output jacks mounted on minibox's end. We suggest you mount R6 so it's adjustable from outside.**

hardware store. This kind of switch is normally used on desk lamps and the like. We have listed in the parts list, however, a rocker-type switch because, on second thought, we feel it is more practical since you can tell at a glance whether it's ON or OFF. Don't care to make a rectangular opening to mount a rocker type, either? Then use a regular toggle switch mounted with a marker plate to indicate its status.

After mounting and wiring all of the components on the perfboard, check your work to be sure you've wired it correctly. Then mount it in position in the bottom half of the Minibox as shown in our photo.

**Getting to the Gig on Time.** Connect the battery, plug your guitar into the input jack, and connect the output jack to the *normal* guitar input on your power amplifier. Standard patch cords in varying lengths are available with a phone plug on one end to match the input jack on *U-Pick-It* and a choice of plugs on the opposite end so you can match the input jack of your amplifier. (More)

Turn both units on, and open switch S1 so that the short circuit it places across *U-Pick-It's* input/output jacks is removed. After the amplifier has warmed up, adjust trimmer potentiometer R6 with a small screw driver to a point just below feedback with potentiometer R8 set at its midpoint position.

Once the setting is achieved, turning the knob on R8 to the right or left of center should now change the sound of the guitar. One extreme in rotation will favor bass and the opposite extreme will favor the treble while R8's midpoint setting will favor the midrange. ■

## Antiquing an Old Tube

*Continued from page 32*

about  $\frac{3}{32}$ -in. in diameter letting the screw cut its own threads in the hole. Clip off the screw leaving about  $\frac{1}{8}$ " projecting from the base and then file the clipped end of the pin smooth.

Caution: Do not drill too deep into the tube base or you might strike the glass inside the base and ruin the tube. Use a depth marker on the drill so you will not drill too deep.

**Who Has It?** Possible sources for type 30 tubes or other battery tubes having the same type bases as the 30s and having low filament voltages and low filament drain:

George Haymans, WA4NED, Box 468, Gainesville GA 30501. George has a good stock of new type 30 tubes at this writing. Write him for prices. He also has type VT-25 tubes which are similar to type 30s.

Barry Electronics, 512 Broadway, New York NY 10012

Cornell, 4213 University Ave., San Diego CA 92105

Steinmetz, 7519 Maplewood, Hammond IN 46324

Transelectronic, Inc., 1306 40th St., Brooklyn NY 11218

United Radio Co., 56 Ferry St., Newark NJ 07105

Zalytron, 469 Jericho Turnpike, Mineola NY 11501

A purist collector may say that you are cheating when you substitute a 30 for an 01A job. Maybe so, but your restored ancient receiver will be operative, and if you're lucky, you may uncover an O1A. ■

## Hour Master

*Continued from page 34*

the board to prevent AC fields from affecting the FET's gate. Regarding relay K1, sensitive types with coil resistances of 1000 to 2500-ohms will work if R3's value is adjusted to give the proper drive to relay-driver transistor Q2, (decrease R3 in 20% steps for more drive). The triac is mounted on perforated board together with a heatsink of 15 gauge aluminum. No insulating washer is needed, but be sure that other parts do not touch the heatsink. Diac D1 is mounted under the board. It isn't polarized so just wire it in. When the board is all done, mount it in the case on a pair of fiber or metal spacers. Make the bracket for the battery from a scrap of aluminum and screw it in place.

**Operating Info.** The triac specified is good for 600 watts, and the phase control will handle anything but fluorescent lamps and induction motors. If you want to handle more power, use a bigger triac in the same series. You will have to if you want to extend control to such high power items as household irons or hotplates. Now, wire the system together being careful to use heavy leads in the power control section.

Connect a floor lamp or worklight to receptacle SO1 and apply primary power to the system. The lamp should now light, and if you've included control R4, the

*(Continued on page 115)*

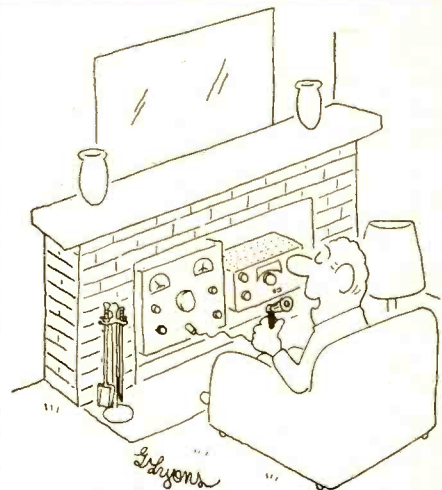

*"I'm running 250 watts straight up the chimney!"*



## Visulert

Continued from page 101

support them away from the metal to prevent shorts. Before soldering electrolytic capacitors and diodes, check to be sure that you have them properly polarized. Also, doublecheck that connections to Q1 and Q2 are correct before soldering to avoid application of too much heat, if you must unsolder and resolder them, since excessive heat can damage solid-state devices. In fact, we recommend that you use an alligator clip as a heat sink by temporarily clipping it to each lead being soldered.

**Remote Lamp.** In the event you require a brighter lamp than the standard bulb listed, or want the lamp located on a wall or site outside the area of the telephone—where it can be universally observed—make the following modification. Remove the bulb and connect the leads to terminal strip TB1 for connecting the remote lamp control leads. Mount a 6.3-VAC relay, a standard 110-V lamp socket, and TB2 in a container suitable for the remote location. Wire it as shown in the schematic. By using low voltage (6.3 VAC) the interconnecting remote control leads can be small-sized insulated wire. The 6.3 V that is switched by the SCR (Q2) to turn the low voltage lamp *on* and *off* will now be used to operate the remote relay, which will, in turn, control 117 VAC to the larger lamp bulb.

**Checking Out Visulert.** After doublechecking your hookup for possible errors, shorts, or cold soldered connections, plug the power

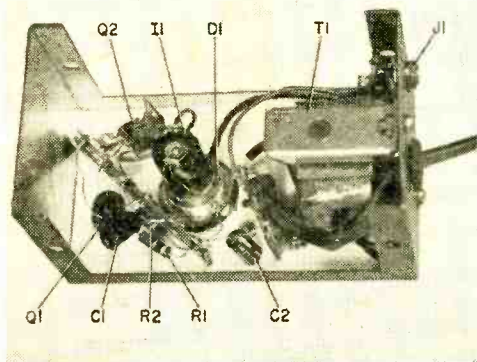

You can see how all of unit's parts are mounted either to tie strips or directly to mini-box in this opened up view of Visulert.



We used conventional round magnetic phone pickup. You may have a flat version available that can be conveniently placed under phone.

cord into an AC outlet, and plug magnetic pickup MP1 into J1. Now bring the pickup near power transformer T1. If the unit is working correctly the radiated AC field around the transformer will produce a signal in the magnetic pickup device, triggering the SCR (Q2) to turn *on* lamp I1. Each time you move the pickup close to the transformer, the lamp will be lit; as you move MP1 away from T1's magnetic field, the lamp will go out. When this checkup has been completed you can close up the mini-box and place Visulert in service.

**Using Visulert.** The suction cup on the pickup coil we used serves a dual purpose. It permits you to easily orient MP1 into the magnetic field of the telephone ringer and also holds it in position once the ideal location is found. If the pickup you use is one of the flat types, place it under the phone near the exit of the handset cable.

Regardless of the type, you'll have to move the pickup around the base of the phone to locate the magnetic field of the ringer. Remember, of course, the only time you can locate the pickup is when the phone is ringing. Reason is that Visulert's operation is dependent upon the relatively high magnetic field of the ringer to develop a control signal to fire the SCR. ■

(Continued from page 113)

brilliance should be variable. Now set power switch S2 to *on* and mode switch S3 to *in*; the lamp will go out. Press time-start switch S1, hold it for a moment and release. The lamp will light and remain on for a period determined by the setting of R1, the time delay control. By plugging

## Diaper Snooper

Continued from page 110

lums who repeatedly rifled my car at night and stole anything that wasn't welded to the floor. The door locks didn't work because they had been broken by thieves months before. Try as I would, I could never catch them in the act. The local police department didn't speak English, and wasn't interested

## Vibra-Tone

Continued from page 76

highly recommended at all points of termination.

**Double Up.** Note that in some instances two pads are required at some termination points. Be sure that these overlap and that solder flows between the pads for a good connection. The components terminated on the pads should be mechanically secure without support from the pad. That is, resistors and capacitors should be pushed through holes in the board so that the component rests firmly on the vectorboard.

Identify the IC's and insert them correctly in the board. Once the IC's are mounted, the other parts, resistors and capacitors can be mounted in any order. Electrolytic capacitors have a polarity marking. Be sure the positive (+) end is properly connected. Tuning resistors R9 to R19 must be the resistance values indicated, and be sure they are  $\pm 5\%$  as specified, otherwise the tuning may be way out. The 5% resistors have a gold band. If the vibrato is too strong causing a break up on the lowest two or three notes, vary the size of resistor R3; an increase will decrease vibrato.

**Tune Up.** Trim pot R8 provides some adjustment of the tone over the entire scale. Adjust this control as required to tune the vibratone. ■

a clock into the output and noting when it turns off at various settings of time delay pot R1, it should be a simple matter to calibrate the control for various settings.

With S3 in the *in* position, the load will be on for the time you select. In the *out* position, the load will turn on after the desired interval. ■

in my problem anyway, so I tried to avoid the problem by keeping all loose items out of the car. I finally solved the problem by moving to a less infested neighborhood, but had I built a switch operated version of this remote radio alarm, it would have enabled me to catch 'em red handed. It could easily be wired to the courtesy light system with a voltage divider to step down the car battery to the voltage required by the unit. Tape the unit to a car window on the side towards the house so the auto frame won't block the transmitted energy. ■

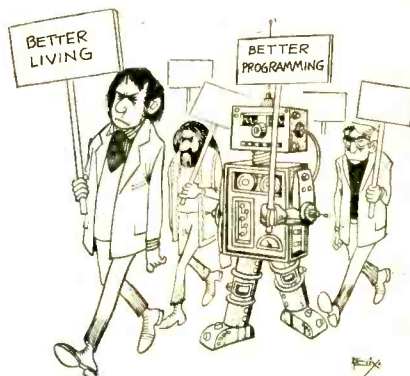

## Alarm Generator

Continued from page 28

resistor and a 5000-ohm pot. Connect a pair of 2000-ohm headphones (or the AUX input of an amplifier-speaker combination to the output and connect a 9 volt power supply to the power leads. Now adjust the pot until you get a good sound. If all's well you should be able to get an attention grabbing sound by adjusting the pots on the front panel. If not, try interchanging the unijunctions. When you are satisfied with the results, remove the pot/resistor

combination, measure it with an ohmmeter, and replace it with a resistor of the closest value.

In operation, the ELECTRONIC ALARM GENERATOR works very well as an alarm device with just headphones as a repro-

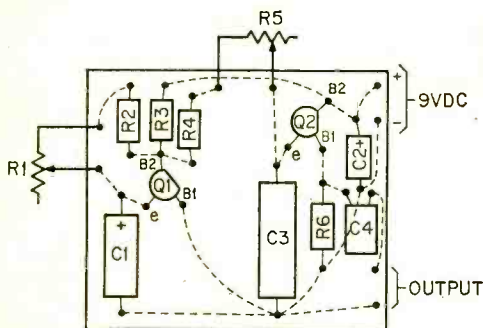

**Top view of the Electronic Alarm Generator**  
Dashed lines represent wiring underneath a completed board. Unit will drive headphones

ducer. If your application calls for more volume, connect it to an amplifier. Just be careful with the special effects. You wouldn't want to attract a flight of passionate wild ducks winging it south this fall! ■

## Detector X2

*Continued from page 26*

graph. Once the leads are carefully soldered, the whole unit can be dipped in a potting compound to protect the leads and protect the components themselves from damage and accidental circuits.

☞ Never use a capacitance value for C1 that is larger than that used for the rf bypass capacitor (C2) in the original detector circuit. Try a value about half that of C2, first. A small-value capacitor will charge to the peak voltage faster than one of too much capacitance. A too-small-value capacitance will discharge too soon. Neither value will give maximum audio voltage output.

☞ It may be necessary to "peak" the detector transformer since the added components will have some capacitive loading effect on the transformer tuning.

**Voltage Multipliers.** It is possible for additional diodes and capacitors to be added for voltage tripling and quadrupling, although selection of capacitors becomes more critical. ■

## Big Nine

*Continued from page 81*

be producing sound at equal loudness. Perform the same test with the tweeters. Operate the controls to see if they reduce the volume of the mid-range, or tweeters, when rotated to the left. Double check your wiring and, if satisfied, solder all lugs. Connect a 1½-volt flashlight battery to the terminal strip. Reverse the battery if necessary until the woofer cone moves forward at contact. Put a drop of red paint on the terminal connected to the positive pole of the battery.

The woofer compartment should be lined with a minimum of about 2 inches of fiber glass batting on the walls and back panel. House insulation grade of fiber glass is low in price and works very well, but first it must be stripped from its paper backing. The fuzzy edge should be faced away from the walls, toward the cabinet interior. The chief purpose of the fiber glass is to kill reflections in the upper frequency of the woofer, but it will also help slightly to reduce any tendency toward booming. You can experiment with different amounts of fiber glass until the woofer sound is right.

Screw down the back, then prepare the top. The top will be installed with screws through the sides, back, and front into blocks under the top. The blocks should be cut to short lengths, except for a long block at the back, so that they can be positioned at intervals between speaker positions. Glue and screw the blocks to the under side of the top. Before installing the top, loosely fill the mid-range compartment with fiber glass pads. Arrange the pads flat so that their edges face the speakers.

**Finishing Touches.** It is somewhat easier to stain and finish the top and trim pieces before putting on the grille cloth. Sand lightly, stain, and finish to your own taste. Staple grille cloth to the back edge of one side and wrap it around tightly; then staple or tack at the back edge of the other side. Install the trim pieces with finishing nails. If glue is not used, you can easily remove the trim and grille cloth later for a change of cloth.

Now connect the speakers to your amplifier. Observe polarity by connecting the red dot terminal of each Big Nine speaker system to the positive sides of your am-



# ELECTRONICS HOBBYIST

## READER SERVICE PAGE

• The Editor of **ELECTRONICS HOBBYIST** offers readers an easy way to get additional information about products and services advertised in this issue. Also, if you would like more information about any new product mentioned in our new products column, it's yours for the asking. Just follow the instructions below and the material you requested will be sent to you promptly and at no cost.

• The coupon below is designed for your convenience. Just circle the numbers that appear next to the advertisement or editorial mention that interests you. Then, carefully print your name and address on the coupon. Cut out the coupon and mail to **ELECTRONICS HOBBYIST**, Box 886, Ansonia Station, New York, N.Y. 10023. Do it today!

Void after March 15, 1974

F/W 1973

**ELECTRONICS HOBBYIST**  
Box 886, Ansonia Station, New York, N.Y. 10023

Please arrange to have literature whose numbers I have circled at right sent to me as soon as possible. I understand that this is a free service offered by the magazine.	1	2	3	4	5	6	7	8	9	10
	11	12	13	14	15	16	17	18	19	20
	21	22	23	24	25	26	27	28	29	30
	31	32	33	34	35	36	37	38	39	40
	41	42	43	44	45	46	47	48	49	50
	51	52	53	54	55	56	57	58	59	60

Name (Print Clearly) \_\_\_\_\_

Address \_\_\_\_\_

City \_\_\_\_\_

State \_\_\_\_\_

Zip Code \_\_\_\_\_

plifier output terminals. Begin listening with the mid-range and tweeter controls fully clockwise. If the sound is too bright, adjust the tweeters back by degrees. If the bass is less prominent than you like, rotate both mid-range and tweeter controls counter clockwise until the sound is balanced. Unless your room is acoustically asymmetrical, such as heavy curtains near one speaker, you should try to keep the controls on both speakers at similar settings for good

stereo performance.

**Hints-On-Parts.** Prices for parts shown in the bill of materials are for CTS speakers available from McGee Radio, 1901 McGee Street, Kansas City MO 64108. However, you can substitute similar-size speakers and parts from other sources such as the 40-1224 tweeter and 40-1339 crossover network from Radio Shack. The crossover includes the L-pads to make the job of interconnecting speakers an easier one. You can even use 3/4-inch flake board in place of the regular plywood to cut your wood costs. Grill cloth, hardware, terminal strips and other miscellaneous items can be purchased from local hardware and electronic stores as well as from your favorite mail order catalog. Smart shopping and use of junk parts can hold your parts costs to as little as \$65 per speaker, and even less.

**Summing Up.** If you are not used to a large woofer, you will note the difference right away. Amplifier controls may require different settings than for small speakers. But the important difference is that there is a firmness to the bass that is missing with most small systems.

With the proper balance you will begin to appreciate the advantage of the side facing speakers. A change of listening position produces much less change in stereo quality than with conventional speakers. Also, the better dispersion produces the illusion of a wider sound source, a big one.

A further advantage is that mid and high frequency power is divided between four speakers. Each of the small speakers is working far below its power limit, with reduced distortion in the frequency ranges where the ear is most sensitive to distortion. The result is a smoother sound. Two Big Nines add up to impressive stereo. ■

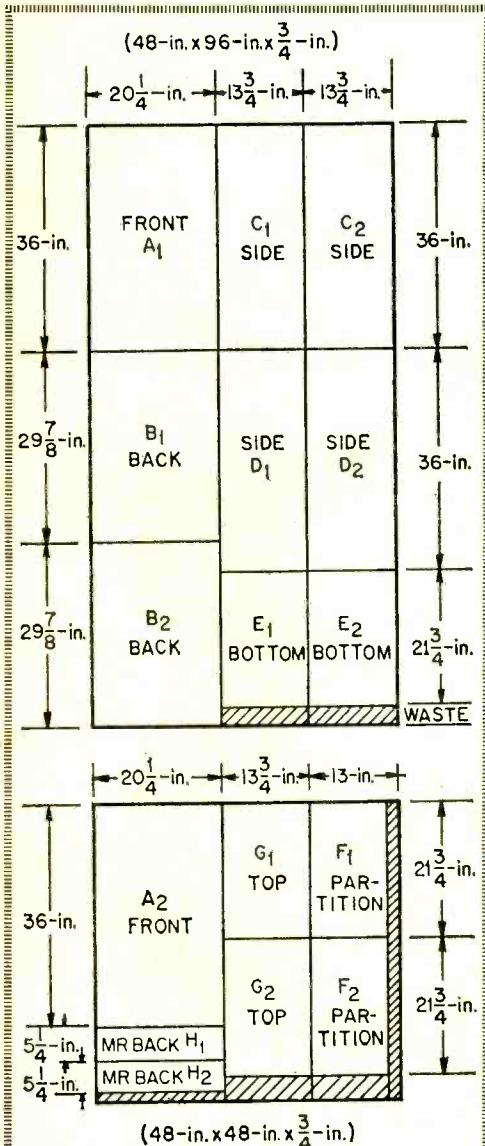

(48-in. x 96-in. x 3/4-in.)

(48-in. x 48-in. x 3/4-in.)

This cutout guide provides you with pieces for two complete systems. The letters refer to those in Figure 1.

## Scramble Phone

Continued from page 94

may easily be removed and replaced with a metal or plastic plate. The clarity potentiometer can be mounted at any convenient location on the phone's base plate, but be very careful not to let any component interfere with the operation of the hook switch.

**Scrambling A Phone.** Connect the two scramble phones together (phone line outputs connected to each other) but separated by at least twenty feet. Lift either of the hand sets and you should hear a low level

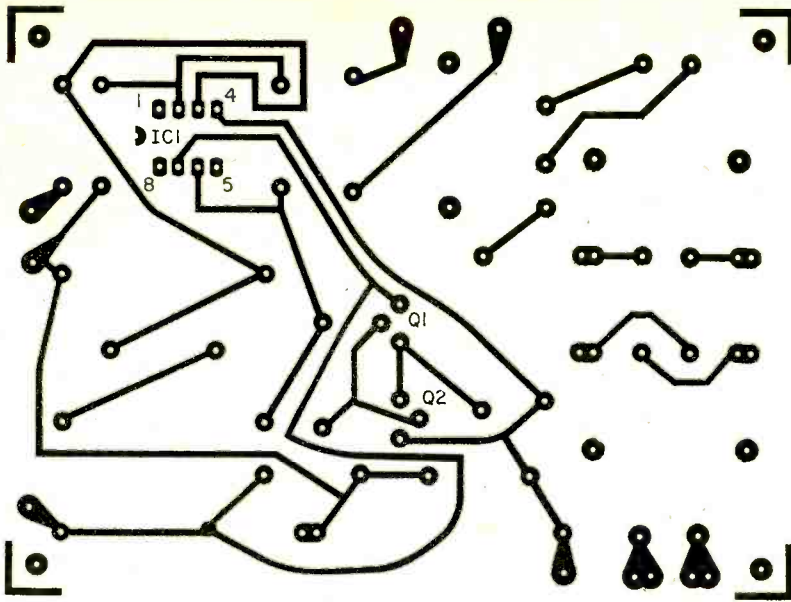

Exact PC board size. Transfer image to copper clad board using a piece of carbon paper. This is the bottom (copper) side of your scrambler board.

tone; talk into the mike and you should hear your own unscrambled voice in the ear piece. This reception of your own voice is normal and occurs when using a standard telephone; it is called the *sidetone*.

Have a friend or another member of your family talk over the scramble phone. If your reception isn't clear or sounds like Donald Duck, adjust the *clarity* control for the best voice quality. This simply puts the two oscillators on the same frequency.

**Scrambler Hook-Up.** This job is a simple one. All that's required is to parallel the output of transformer T3 with the telephone lines. But before doing so, make the following tests. If you are in doubt about which two wires on the telephone terminal block are the telephone circuit, take a DC volt meter and check between pairs until 24 to 48 volts is measured. This test must be performed with the telephone on hook. The second important check to make before connecting the scrambler phone determines the line current. This test is made as follows. Set the VOM to measure DC current on the 50 or 100mA range, and place the meter in *series* with a lead from the high (1.2 K) impedance winding of T3. Pick up the phone. If the circuit current is greater than 25mA, then the resistor/capacitor network C6 and R9 must be added in series with the scrambler phone and the telephone circuit. This should reduce the circuit current to a value close to 25mA, but if not, adjust the value of R9 (start with a 1000-ohm, 1/2-watt resistor) until this current value is

reached.

**Security Link-Up.** After connecting one of the scrambler phones at your location and another at the home of a friend, dial his number with your standard telephone. When the party answers and agrees to go to the scrambler mode, pick up your scramble phone, and have your friend do the same. You can now continue your conversation in complete secrecy. If either of the scrambler oscillators should drift in frequency, just set the *clarity* pot for the best voice quality. ■

## Cap Rapper

*Continued from page 67*

reading you have pre-set the trimmers in the wrong direction. Set S1 to 100 (pF), install a calibration capacitor across the terminals, and adjust R4 until the meter indicates the correct capacitor value. In a similar manner, calibrate the .001, .01 and .1 ranges. Recommended calibration capacitor values are *approximately* 50 pF, .0005  $\mu$ F (500 pF), .005  $\mu$ F and .05  $\mu$ F.

If you cannot adjust the trimmers so the meter indicates a *low* enough reading (if the meter reads higher than the indicated capacitor value) you had the trimmer pre-set to the wrong side. Simply rotate the trimmer to the opposite side; the meter reading will rise, pin the pointer and then decrease to the correct reading as the trimmer(s) are adjusted. ■



# CLASSIFIED Market Place

FOR BIGGER PROFITS! NEW CAREER OPPORTUNITIES!  
READ AND REPLY TO THESE CLASSIFIED ADS

Classified Ads 65¢ per word, each insertion, minimum 15 words, payable in advance. For information on Classified ads—to be included in our next **ELECTRONICS HOBBYIST**—write R. S. Wayner, Classified Mgr., 229 Park Avenue South, New York, N. Y. 10003.

## ADDITIONAL INCOME

WIN \$1,000,000.00 in the New Jersey State Lottery. Rush \$3.00 for complete details and instructions. Satisfaction Guaranteed. Davidson's, Box 274-SM, Belleville, Illinois 62222.

## AGENTS WANTED

ADULT Films 1000 Titles, Send \$1.00 and Phone Number B & R Tape Company, Box 118, Bryan, Texas 77801.

## AUTHORS SERVICE

Publish your book! Join our successful authors: publicity advertising promotion, beautiful books. All subjects invited. Send for free manuscript report and detailed booklet. Carlton Press, SMH, 84 Fifth Avenue, New York 10011.

## AUTO PARTS & ACCESSORIES

AIRMASTER Gas Saver. Fits All Cars. \$14.95. Airmaster, Lenora, Kansas 67645.

SAVE GAS. Instant mileage Computer. Satisfaction Guaranteed. \$2.00. Schurman 5002 San Vicente, Los Angeles, Calif. 90019.

## BLUEPRINTS, PATTERNS & PLANS

NEW CRAFT PRINT CATALOG—choose from over 100 great easy-to-build plans. Send \$1.25 (completely refunded with your first order). BOAT BUILDER, (CP Div.)—229 Park Avenue South, New York, N.Y. 10003.

## BOOKS & PERIODICALS

WIRETAPPING Expose! Your Privacy Invaded. Details \$1.00 (Refundable). Don-Q, Box 548, Seattle, Washington 98111.

\$10.00 GIFT Certificate Free With Giant Adult Catalog. Send \$1.00 To: D. EG. Slater, Route 3, Box 59, Mission, Texas 78572.

## BUSINESS OPPORTUNITIES

I made \$40,000.00 Year by Mailorder! Help others make money! Start with \$15.00—Free Proof! Torrey, Box 318-T, Ypsilant, Michigan 48197.

MAKE Magnetic Signs. Big profits. Details. Universal, Lenora, Kansas 67645.

1000% PROFIT Bronzing Baby Shoes In Your Home. Free Honest Facts. NBC-DG. Gower, Mo. 64454.

HERBALISM! The home gold mine! Free lesson. Seeds. Herbalism institute-D, 1339 Remuda, Glendora, Ca 91740.

## BUSINESS OPPORTUNITIES—Cont'd

HOW To Make Money Addressing. Mailing Envelopes. Offer Details 10¢. Lindbloom Services, 3636 Peterson, Chicago 60659.

FREE—Wholesale Catalog and Sales Plan. JAM Enterprises, 3100X Liberty Avenue, Pittsburgh, Pa. 15201.

FREE Book "2042 Unique, Proven Enterprises." Beat inflation with fabulous, successful "Little Knowns." Work Home! Haylins-Ell, Carlsbad, Calif. 92008.

SELL SELF HELP (ALPHAGENIC) RELAXED MEDITATION CASSETTE TAPES. They really work for golfers, plain Janes, lonely hearts others. High profit repeat sales. Dealer info \$1.00. BERGQUIST, Box 1307, Temple, Az. 85281.

\$1000 MONTHLY possible from your own home. write Jordan, Box 884, Dept. DC7, Visalia, Calif. 93277.

BUSINESS for sale by owners, send for free brochures. Indicate kind, location, price. Interstate Business Marketing, P.O. Box 1888, Pueblo, Co. 81008.

## CAMERAS & PHOTO SUPPLIES

POPULAR Cameras—Accessories! Best Prices! Mandarin, 214 Shawns Building, Hong Kong.

## COINS, CURRENCY & TOKENS

CANADIAN! Silver Dollars 1968-73 Ten for \$14.95. Silver Halves 1910-66 Twenty for \$13.95. Benny Lee Ltd., 331 W. Pender St., Vancouver, Canada.

## DO-IT-YOURSELF

CONVERT TV to 6-ft. wide screen! B&W/Color. Do-It-Yourself—easy! Kit. Instructions, lens, \$12.95 up. Free Illustrated Details. Macrocoma, SMC-9, Washington Crossing, Penna. 18977.

## EDUCATION & INSTRUCTION

HIGH SCHOOL DIPLOMA for adults. Earn State Diploma. Accepted by Civil Service, business, colleges. Low cost. No tedious study. Money-back guarantee. Details: H-S Programs, Suite 25 22,1221 Avenue of Americas, New York, N. Y. 10020.

ORDINATION Certificate. Details Free Ministry of Service, Box 526, Seymour, Texas 76380.

## FARMS, ACREAGE & REAL ESTATE

GOVERNMENT LANDS—Low as \$1.25 Acre! Buy, lease or homestead. Free Details! Lands Digest, Box 25561-JC, Seattle, Wa. 98125.

## FARMS, ACREAGE & REAL ESTATE Cont'd

FORTUNES IN LAND! Buy CHEAP! On SIGNALS! Your community or any state. Free information. Land Signals, DLDP-3, Box 325, Scottsville, Texas 75688.

## GIFTS THAT PLEASE

FREE CATALOG OF UNIQUE GIFTS. Write: A&V Mailorder Specialties, C5, Route #1, Moorefield, Nebraska 69039.

## HEARING AIDS

HUGE SAVINGS! BUY DIRECT! Eliminate dealer markups 20 days FREE Trial Terms arranged. No salesman will call. LLOYD'S-79, Rockford, Illinois 16108.

## HYPNOTISM

HYPNOTIZE STRANGERS in 30 Seconds! Most powerful hypnotic device ever created! Complete easy instructions included. Guaranteed only \$2.00. From: WORLD-30C9, 3047 University, San Diego, Ca. 92104.

## INVENTIONS WANTED

We either sell your invention or pay cash bonus. Write for details. Universal Inventions, 298-3, Marion, Ohio 43302.

## LOGIC

LOGIC NEWSLETTER. Design, Theory, construction. Sample copy \$1.00. Logic Newsletter, POB 252, Waldwick, N. J. 07463.

## MAGIC TRICKS, JOKER NOVELTIES & PUZZLES

CATALOG 10¢ 1,500,399 Tricks, Novelties, Jokes, Etc. Elbee, 7408-S, San Antonio, Texas 78207.

## MONEYMAKING OPPORTUNITIES

Guaranteed Home Income raising chin-chillas 25¢. Chinchilla, 11DC2, Fort Richey, Fla. 33568.

\$40.00 DAILY possible tying fishing flies at home. Details 25¢. Flyco, Box 481-EH, Albany, Oregon 97321.

\$2500.00 MONTHLY in your mailbox GUARANTEED. Send 25¢ + stamped self addressed envelope. Odyssey, Box 12560DC, Philadelphia, Pennsylvania 19151.

Make Your Classified Ad Pay. Get "How To Write a Classified Ad That Pulls." Includes certificate worth \$2.00 toward classified ad in S & M. Send \$1.25 (includes postage) to R. S. Wayner, Science & Mechanics, 229 Park Ave., South, New York 10003.

THERE IS NO CHARGE FOR THE ZIP CODE—PLEASE USE IT IN YOUR CLASSIFIED AD

# CLASSIFIED MARKET PLACE—Cont.

## MONEYMAKING OPPORTUNITIES Con't.

**SELL Your Photos.** Report tells How. Where. Color Slide Markets. Only \$1.00. Charlene's, 8600 East Evans Avenue. Denver, Colorado 80231.

**JOIN "Money-Getters Guild"** 25¢. Russell Advertising, Box 612-D New Philadelphia, Ohio 44663.

## MUSIC & MUSICAL INSTRUMENTS

**TAPES** don't have to cost a fortune. Our catalog offers a complete selection of over 1,000 8-Tracks, Cassettes, and LP's at below 50% off. Write now for a free catalog to: Eastern Music Distributors, Dept. 109, 2568 East 21st Street, Brooklyn, New York 11235.

## OF INTEREST TO WOMEN

**\$25.00 DAILY** Possible addressing-stuffing envelopes Typewriter-longhand, also Clipping News items at home. Information: Send stamped addressed envelope. Ame-7, Box 310, Le Mars, Iowa 51031.

## OPTICAL GOODS—TELESCOPE

**EYEGLASSES Wholesale—Free Catalog.** A-Z Optical Company, Box 175, Dept. 28 E. Bay Station, Brooklyn, N.Y. 11235.

## PERSONAL

**ORIENTAL** introductions! Photographs, descriptions, questionnaire, brochure, details. \$1.00. INTER-PACIFIC, Box 30 SC, Birmingham, Michigan 48012.

**SINCERELY** interested in Marriage? Fourteen Years experience. Social Introduction Service, Box 1547, Eugene, Oregon 97401.

## PERSONAL Con't.

**CONTRACEPTIVES** for Men—by mail! Eleven top brands—Trojan, Conture, Jade, and many more. Three samples: \$1. Twelve assorted samples: \$3. Free illustrated catalogue with every order. Plain package assures privacy. Fast and reliable service. Satisfaction guaranteed or your money refunded in full. POPLAN, Box 2556-DCG6, Chapel Hill, N.C. 27514.

**AVOID** Embarrassment. Latex family planning items available privately by mail. Free details. Donald King, Box 336C, Ehrenberg, Arizona 85334.

## PHOTOGRAPHY—PHOTO FINISHING

**SAVE HUNDREDS OF DOLLARS!!!** Make your own S&M Densitometer. Send \$3.00 for detailed drawings and instructions. A must for successful Photography in your darkroom. Order direct from: S & M Instruments, Dept. EH9, 229 Park Avenue South, New York, New York 10003.

## RADIO & TELEVISION

**"DISTANCE One Tuber"** Handbook—50¢. 15 Distance one tube plans—25¢ Catalog 25¢, refundable. Laboratories, 1477 EH, Garden Grove, California 92642.

**TV TUBES** 36¢ each. Send for Free 48 page color catalog. Cornell, 4217-W University, San Diego, California 92105.

**FREE CATALOG—Tremendous** electronic bargains. Computiks, Box 41885, Mountain View, Calif. 94040.

**DISCOVER** how to avoid calling the serviceman. Save by servicing home equipment yourself. Send \$1.25 for magazine. **RADIO-TV REPAIR—229 Park Avenue South, New York, New York 10003.**

## REMAILING SERVICE

**RECEIVING - Forwarding - Remailing.** monthly rates. Nortex, Drawer 430, Weatherford, Texas 76086.

## SALESMEN—DISTRIBUTORS

**"PERMANENT Match-Pen"** fast seller, brand new. Ball point pen and instant lighter combined. Sample \$1.50. H. Blanchard, 206 Plain St., Stoughton, Ma. 02072.

## SCIENCE & CHEMISTRY

**LASER Tube—\$9.50.** Bargain Laser Catalog—\$1.00 (Refundable). Plasma Systems. "EHS73", Box 3261, San Jose, California 951106.

## STAMP COLLECTING

**FREE** Stamps, Approvals. Send 10¢. UX Stamp Co. 320 Congress, Austin, TX, 78701.

## SURPLUS EQUIPMENT

**GIANT** 120 Page Canadian Surplus Catalog \$1. Etc. Dept. DG, Box 741, Montreal.

**BARGAINS:** Surplus Electronics, free catalog. Atlantis (EH), Box 12654, Tucson, Arizona 85711.

## TREASURE FINDERS—PROSPECTING EQUIPMENT

**SUCCESSFUL** Treasure Hunters use White's Detectors from: Paul B. Marvel, R. D. 1, Box 83-EH, Frankford, Delaware 19945.

# EARN HUNDREDS OF DOLLARS MORE!!

## WITH S & M SUPERSENSITIVE PHOTO METERS

Use the **MODEL A-3 DARKROOM METER** with dial lights to become a darkroom PRO. It is **EASY** to use at the enlarger with the ½ in. high EASEL probe to determine accurate exposures for B & W or color photography.

Use the A-3 to improve your darkroom skills; to eliminate waste of prints, chemicals and time; to standardize your work for increasing productivity and earning by **HUNDREDS OF DOLLARS.**

Use the **MODEL 102 LIGHT METER** with **STANDARD** probe to determine exposures from dawn to twilight, to moonlight! **SPECIAL FEATURES?** Four sensitivity ranges; EV-EVS-LV settings; ASA settings from 3 to 25,000; f/stops from 0.7 to 90; exposure times from 1/15,000 sec. to 8 hours.

Use the A-3 or Model 102 as a densitometer to find the highlights and shadow densities of your negatives and the **CORRECT** paper for printing.

**OTHER APPLICATIONS?** Ground-glass, slides, photomicrography, holography and **MORE!**

These marvelously accurate and extremely sensitive battery-powered Meters use plug-in probes. Each is supplied here with the probe of your choice, exposure computer, carrying case and manual. This is your opportunity to use one free for 10 days without obligation. Mail the coupon today.

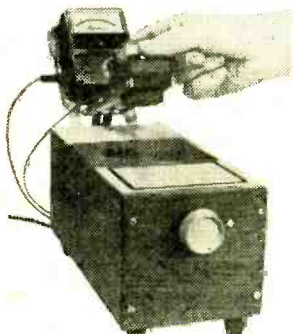

**SCIENCE & MECHANICS, Instruments Division,** Dept. EH-FW3, 229 Park Avenue South, N.Y., N.Y. 10003

Send the S & M Photo Meter with probe indicated, computer, case and manual. Complete instructions supplied to make your own densitometer. If not satisfied, I may return the Meter within 10 days for a complete refund.

(Add 10% for Canadian and Foreign orders; N.Y.C. residents add 7% for sales tax.)

- Darkroom Model A-3 @ \$79.95 with
- Light Meter Model 102 @ \$57.50 with
- Standard probe;  Easel probe; or  Mini-probe.

For additional probes:

- ½ in. diameter Standard probe @ \$7.50
- ½ in. high Easel probe @ \$7.50
- ¾ in. diameter Mini-probe @ \$7.50
- Densitometer probe \$7.50

- Check or money order enclosed, ship ppd.
- Company Purchase Order attached.

NAME \_\_\_\_\_  
 ADDRESS \_\_\_\_\_  
 CITY \_\_\_\_\_  
 STATE \_\_\_\_\_ ZIP \_\_\_\_\_



# NOW you can train at home building a NEW 25" DIAGONAL Solid State Color TV engineered by NRI for learning and trouble-shooting

*So much better for learning TV servicing than any hobby kit, because NRI designed and created it as an educational tool.*

Unlike hobby kits which are designed for creating a TV set as the end product, NRI built its exclusive 25" Diagonal Solid State Color TV kit as a real training kit. You can introduce and correct defects . . . for trouble-shooting and hands-on experience in circuitry and servicing. The kits include a wide-band oscilloscope, color bar crosshatch generator, transistorized volt-ohmmeter and other valuable equipment that can soon have you earning \$5 to \$7 an hour servicing color sets in your spare time.

**Handsome woodgrain cabinet, at no extra cost. (Offered only by NRI)**

**New square-cornered Sylvania picture tube**

**100% solid state chassis**

**6-position detented UHF channel selector**



**Modular construction with plug-in circuit boards**

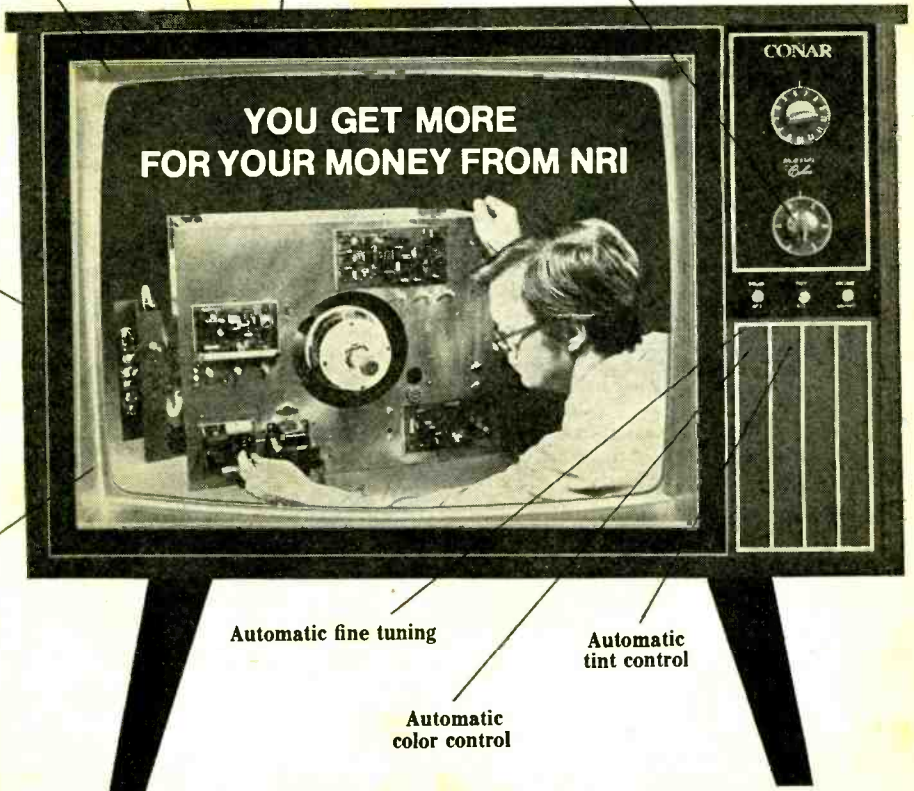

**Automatic degaussing**

**Automatic fine tuning**

**Automatic tint control**

**Automatic color control**



# NRI FIRSTS make learning Electronics fast and fascinating—to give you priceless confidence

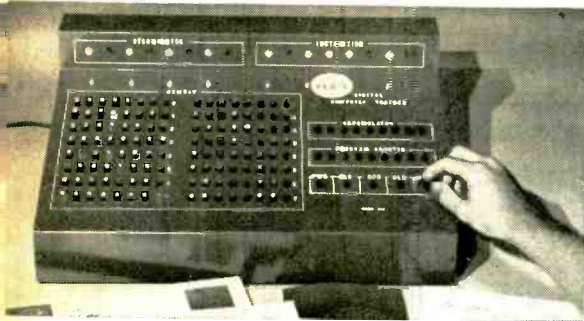

**FIRST** to give you a complete programmable digital computer, with memory, you build yourself . . . to learn organization, operation, trouble-shooting and programming. This remarkable computer is one of ten training kits you receive with the new NRI Complete Computer Electronics Course.



**FIRST** to give you true-to-life experiences as a Communications Technician. Every fascinating step you take in NRI Communications training, including circuit analysis of your own 15-watt, phone/cw transmitter, is engineered to help you prove theory and later apply it on the job. Studio equipment operation and trouble shooting become a matter of easily remembered logic.



**FIRST** to give you completely specialized training kits engineered for business, industrial and military Electronics Technology. Shown is your own training center in solid-state motor control and analog computer servo-mechanisms. Telemetering circuits, solid-state multivibrators and the latest types of integrated circuits are included in your course.

The NRI color TV and digital computer kits are the latest in a long line of "firsts" for NRI. For more than fifty years, NRI has been providing unique 3-dimensional home-study training that has helped hundreds of thousands of students reach their goals quickly and easily.

What NRI provides is a combination of kits and bite-size texts that give you hands-on experience while you are learning. The texts average only 40 pages each, and they are fully illustrated. You are taken step-by-step from the first stages into the more advanced theory and techniques . . . with an expert instructor ready at all times to provide valuable guidance and personal attention. (The level of personal attention provided is more than you would receive in many classrooms.) Once you've grasped the fundamentals, you move with confidence and enthusiasm into new discoveries in the fascinating world of electronics.

You start out with NRI's exclusive Achievement Kit, containing everything you need to get moving fast. Lessons have been specifically written so that experiments build upon one another like stepping stones. You can perform a hundred experiments, build hundreds of circuits . . . as you learn to use the professional test equipment provided, building radios and TV sets, transmitter or computer circuits. It's the priceless "third dimension" in NRI training . . . practical experience.

## Train with the leader—NRI

Compare training kits, texts, techniques and overall training . . . and you'll find that you get more for your money from NRI. Whatever your reason for wanting more knowledge of Electronics, NRI has an instruction plan that will meet your needs. Choose from major programs in Advanced Color TV Servicing, Complete Computer Electronics, Industrial Electronics and the other special courses designed to meet specific needs. With NRI home training, you can learn new skills while you're still working at your present job . . . and turn yourself into the man in demand.

### GET FACTS ABOUT GI BILL

If you have served since January 31, 1955, or are in service now, check GI line on postage-free card.

## Send for free NRI catalog

MAIL THE POSTAGE-FREE CARD FOR THE FREE NRI CATALOG IN THE FIELD OF YOUR CHOICE. YOU WILL BE UNDER NO OBLIGATION. NO SALESMAN WILL CALL.

If the card has been used, write direct to:



**NRI TRAINING**  
3939 Wisconsin Ave.  
Washington, D.C. 20016

# You'll read it first in



Here is your introduction to this great magazine of automobiles, home improvement, science, new products and new ideas. S&M brings you each issue for even less than the low, low single copy price. **TAKE ADVANTAGE OF THE PUBLISHER'S DISCOUNT SAVINGS CERTIFICATE AND SAVE UP TO \$6.86!** (See Coupon below.)

### Why we make this unprecedented offer to new readers

Science & Mechanics is fast becoming the favorite recreation magazine for people who want to have fun with all new developments in the "mechanical" field today... without any mechanical experience needed!

And the one issue you bought at the newsstand (or borrowed) is not enough to show you how Science & Mechanics reports to you about your special recreation interests. Not just cars, but boats, motorcycles, airplanes, all-terrain vehicles, surf-sailing, snowmobiles, motor homes and campers... as well as fields of current concern, such as ecology, blackouts, transportation, many more with a scientific or mechanical basis.

Until you actually read the first few issues, you'll find it hard to believe that every month Science & Mechanics brings you such an enormous variety of useful information and reading pleasure. You'll read it just for enjoyment... use it for the

wealth of helpful, money-saving hints and ideas it offers. Science & Mechanics is the single magazine that can stir your imagination if you're the kind of person who is curious about things that might concern you or your family. Or if you're just interested in what's happening as a result of today's fast-moving science achievements.

### Know where to find the answers— subscribe now

In Science & Mechanics, you discover things you can find nowhere else. And if you can find it elsewhere—**YOU'LL FIND IT FIRST IN S&M!**

And, unlike other magazines in the field Science & Mechanics doesn't just write about well-known personalities. You'll find such newsmakers as Mario Andretti, Andy Granatelli, Don Garlitz, Raymond Loewy, Cotten Owens, Mark Donohue, Senator Proxmire, Senator Brooke often writing about themselves for S&M.

Try Science & Mechanics. Try it under the no-risk subscription offer shown in the coupon. Just fill it in, and mail the coupon to Science & Mechanics, P.O. Box 2600, Greenwich, Connecticut 06830. Send your subscription in **TODAY.**

**Publisher's  
Discount  
Savings  
Certificate**  
●  
**Good for  
up to  
\$6.86  
in  
Savings!**

- Send me 12 Months of SCIENCE & MECHANICS for ONLY \$2.57 (Regular newsstand price \$6.00).
- Yes! Double my savings. Send me 24 Months for ONLY \$5.14 (I save \$6.86 off the newsstand price).
- Bill me     Payment enclosed
- New Order     Renewal    **B808**

Name \_\_\_\_\_  
(please print)

Address \_\_\_\_\_

City \_\_\_\_\_ State \_\_\_\_\_ Zip \_\_\_\_\_

Mail coupon TODAY to: SCIENCE & MECHANICS  
P.O. Box 2600, Greenwich, Conn. 06830