

ELECTRONICS

C&E HOBBY HANDBOOKS

Electronics Theory Handbook

WPS 36288

SPRING 1985 \$2.50
IN CANADA \$2.75

PRIMER ON BASIC AC THEORY

Robots
Are
Here

Power
Supply
Design

Amps
And
Op-Amps

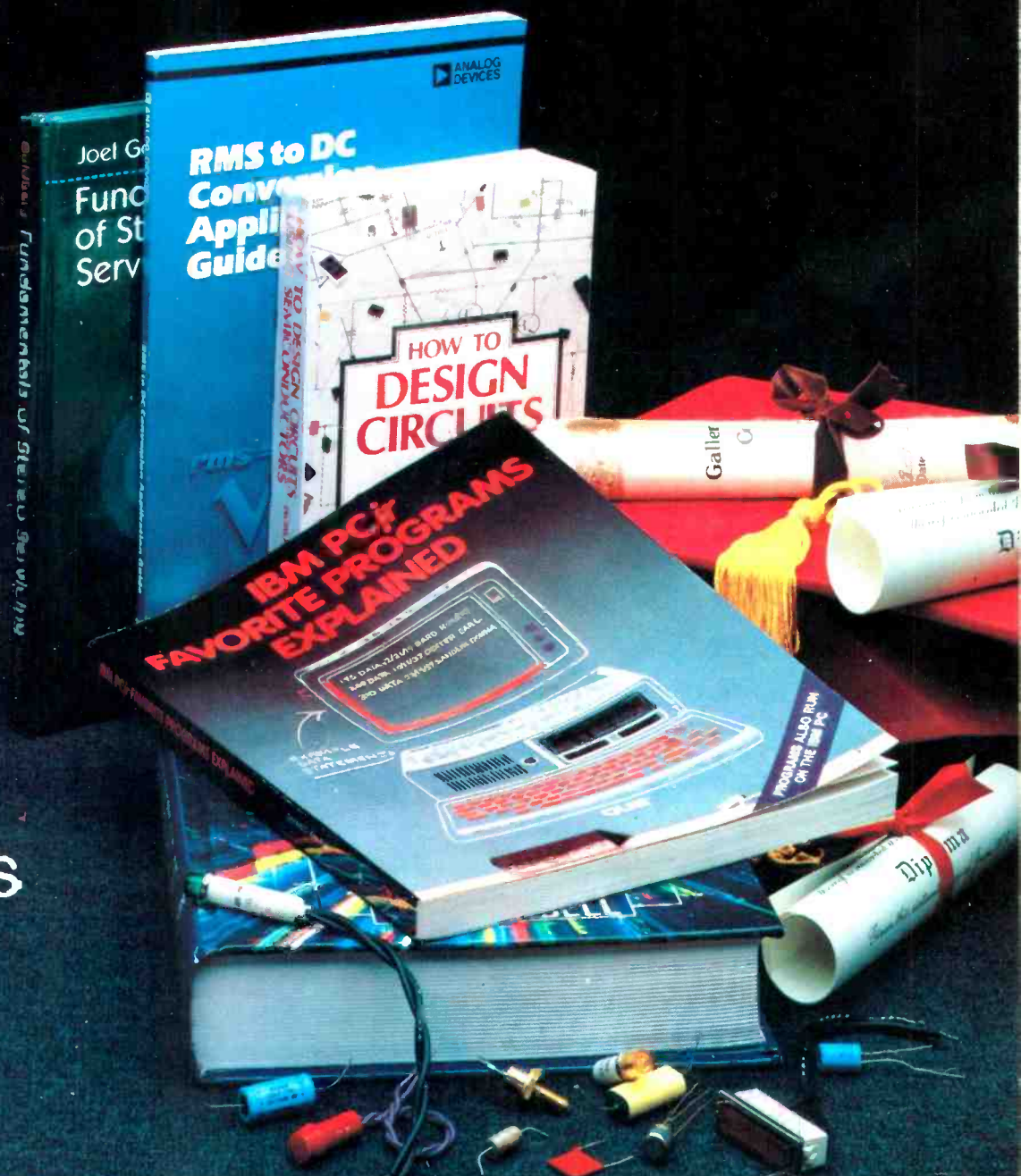

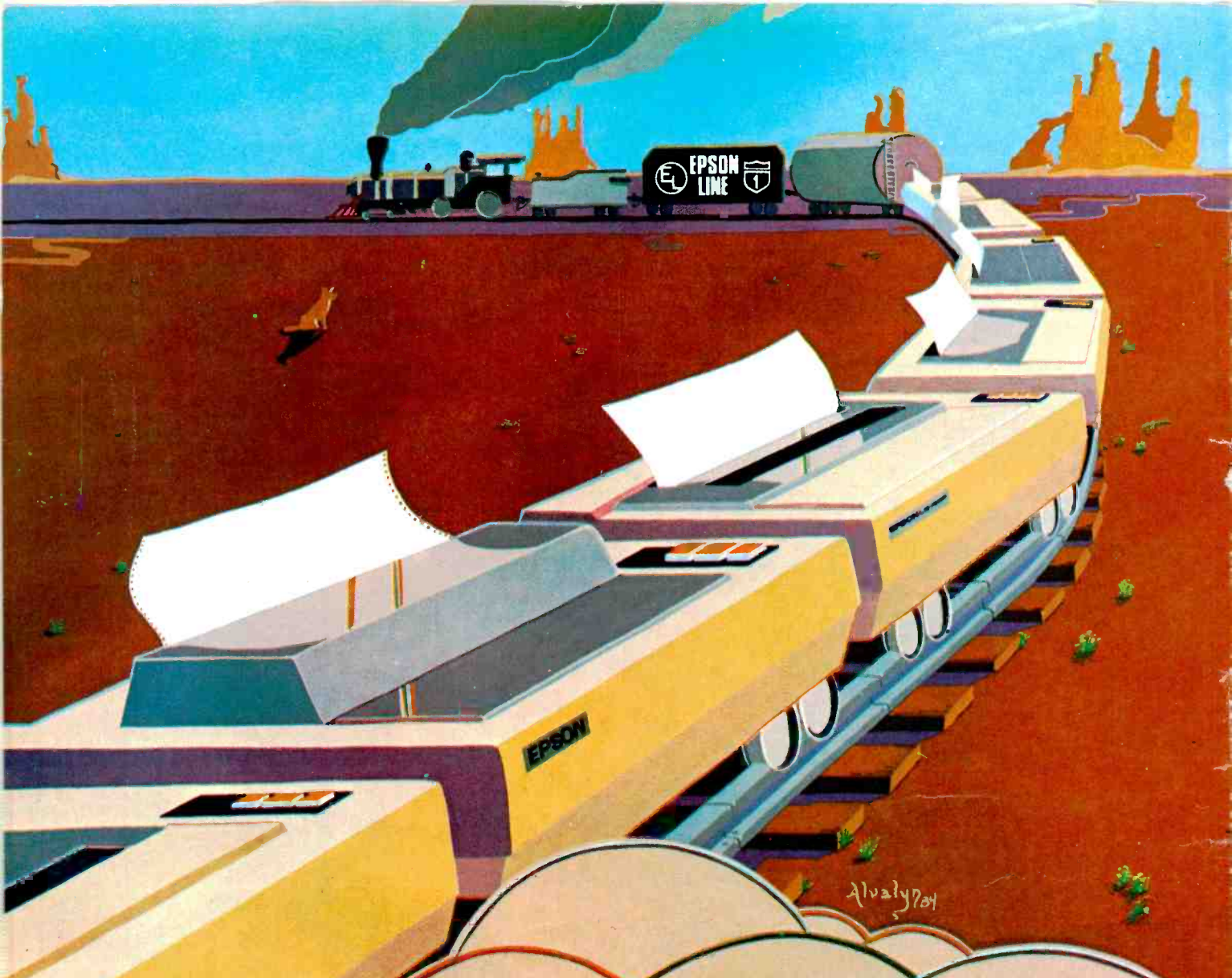

The Epson® Line. A printer for all reasons.

Epson is the best-selling name in printers for small computers the world has ever seen.

Because we make the right printer for virtually every computer. And every job.

Something for everybody.

Our reliable, affordable RX™ Series printers, for instance, are perfect for the small business or home user. Our FX-80™ and wide-carriage FX-100™ provide all the speed, graphics capability and features anyone could ask

for. And our new LQ-1500 is an astonishing breakthrough for business—it switches effortlessly between letter quality and high speed draft printing.

What's more, any printer you buy in the U.S. with the Epson name on it is guaranteed for a full year. Which is four times longer than the guarantee on most printers.

Get on board.

No matter what kind of computer you own, or what job you intend for it, your printer should be an Epson.

Because we build a better printer, price it fairly, guarantee it longer, and give you the one thing you don't always get from a printer company.

A choice.

Number one. And built like it.

EPSON
EPSON AMERICA, INC.

2780 Lomita Boulevard • Torrance, CA 90505 • Call (800) 421-5426 for the Epson dealer in your area. In California call (213) 539-9140.

Epson is a registered trademark of Epson Corporation. RX, FX-80 and FX-100 are trademarks of Epson America, Inc.

Electronics Theory Handbook

THE STAFF

PUBLISHER
Don Gabree

ASSOCIATE PUBLISHER
H.M. McQueeney

CREATIVE COORDINATOR
Tony DeStefano

SECRETARY/TREASURER
Lillian Beck

CONTROLLER
William Aronson

EDITOR
Hank Scott

ART DIRECTION
Newgraphics, Inc.

ASSOCIATE ART DIRECTOR
Joe DeStefano

MARKETING MANAGER
Jordan Malmel

ADVERTISING SALES
C&E Hobby Handbooks, Inc.
300 W 43rd Street
New York, N.Y. 10036
(212) 397-5200

EAST COAST
Worldwide Publications
(201) 231-1518

WEST COAST
J.E. Publishers Representative
(213) 467-2266

Electronics Theory Handbook, Volume 8, Number 3, a quarterly publication published by C&E Hobby Handbooks, Inc. Editorial and Business offices 300 W 43rd Street, New York, N.Y. 10036, (212) 397-5200. PERMISSIONS: Material in this publication may not be duplicated or reproduced in any form without permission. Requests for permission should be directed to—Don Gabree, C&E HOBBY HANDBOOKS, INC., 300 W 43rd Street, New York, N.Y. 10036 (212) 397-5200, ISSN 0364-9067. ADVERTISING OFFICES: New York, 300 West 43rd Street (212) 397-5200 or (201) 231-1518. Los Angeles, J.E. Publishers Rep. 6855 Santa Monica Blvd., Los Angeles, CA 90038 (213) 467-2266. EDITORIAL CONTRIBUTIONS must be accompanied by return postage and will be handled with reasonable care; however, the publisher assumes no responsibility for the return or safety of manuscripts, artwork or photographs. All contributions should be addressed to PUBLISHER, C&E HOBBY HANDBOOKS, 300 W. 43rd Street, New York, N.Y. 10036. C&E Hobby Handbooks Inc. a division of J.Q. Adams Productions. Second Class Entry applied for. Copyright © 1985 by C&E HOBBY HANDBOOKS, Inc.

CRYSTALS

32.768khz	1.85
1.0mhz	3.85
1.8432	3.85
2.0	2.85
2.097152	2.85
2.4576	2.85
3.2768	2.85
3.579545	2.85
4.0	2.85
5.0	2.85
5.0688	2.85
5.185	2.85
5.7143	2.85
6.0	2.85
6.144	2.85
6.5536	2.85
8.0	2.85
10.0	2.85
10.738635	2.85
14.31818	2.85
15.0	2.85
16.0	2.85
17.430	2.85
18.0	2.85
18.432	2.85
20.0	2.85
22.1184	2.85
32.0	2.85

DIP SWITCHES

MS4	\$.78
MS6	.88
MS8	.95
MS10	1.25

OSCILLATORS

1Mhz	9.6768	19.6608
2.4576	10.000	20.000
2.7648	10.240	20.100
3.120	13.230	23.6725
3.6864	14.000	24.00
4.000	14.31818	25.000
4.032	14.175	28.636
4.9152	14.7456	26.824
5.000	15.000	29.498
5.0688	16.000	30.000
6.000	16.257	32.000
6.336	16.984	35.488
7.168	18.000	40.000
8.000	18.432	50.000
9.216	18.6624	80.000
9.218	19.3536	

PRICE EACH

1	\$18.95
10	\$13.95
25	\$ 9.95

I/C SOCKETS

8 pin ST	12	20 pin ST	28
14 pin ST	14	24 pin ST	29
16 pin ST	16	28 pin ST	38
18 pin ST	19	40 pin ST	48

800-341-4468



World Distributors, Inc.

709 N. Memorial Parkway
Huntsville, Alabama 35801
(205) 539-0441



TLX 810-726-2135/810-726-2174

TERMS: Shipping & Handling Charge \$2.50
Min. Charge Order \$15.00

KeproClad

by Kepro Circuit Systems, Inc. T.M.

At Home Professional Quality Fine Line PCB's.

Introducing an easy, inexpensive, step by step method for the home production of professional quality printed circuit boards without a major equipment investment—KeproClad, by Kepro, makers of quality industrial equipment and supplies. KeproClad was designed for the home user who needs professional results with:

A Simple Circuit Board;

Use KeproClad unsensitized copperclads. These boards come in 2 popular sizes with 1 sided foil, a marking pen, all for a suggested retail price as low as \$3.50.

A Fine Line Detailed Board;

Use KeproClad photosensitized copperclads. Available in 2 sizes with 1 or 2 sided foil. These copperclads use the latest technology of negative acting dry-film photoresist. This material is rugged, yet holds extremely fine detail. It comes with a pre-measured amount of developer and sells for as little as \$3.90 (suggested retail).

Other KeproClad products such as a photo reversal kit for making negative film, etch, tin plating solution and photoflood lamps are all available at your local distributor. (For the distributor nearest you, call or write:

KEPRO CIRCUIT SYSTEMS, INC.
630 Axminster Drive., Fenton, MO 63026-2992
In MO 314-1630 Toll Free 800-325-3878

Electronics Theory Handbook

4 — Editorial **5** — Letters **6** — New Products **8** — Bookmark

FEATURES

- | | |
|--|---|
| 9 — Solar Electricity | 68 — Synthesizer Science |
| 12 — The Robot's Are Here | 72 — Solar Power Station |
| 17 — Inside Test Equipment | 73 — Power Supplies
for IC Circuits |
| 24 — Basic Course In AC Theory | 76 — Op-Amps —
How to Use Them |
| 43 — The Way AVC Works | 79 — Amplifiers that Oscillate |
| 46 — How Transmitters Work | 83 — AM/FM Receiver Alignment |
| 50 — Inside Your Power Supply | 86 — Signal Propagation |
| 53 — Understanding Electronics | 88 — The UART |
| 61 — Electronics Language | 92 — Understanding Superhets |
| 63 — How Floppy Disk Systems Work | |

COVER PHOTO: GEORGE MATTEI



ELECTRONICS BOOK CLUB

The Best Source for Hobbyists and Professionals
for Over 19 Years!

Time- and Money-Saving Advice . . .
Practical Troubleshooting & Repair Tips . . .
State-of-the-art Technology . . . Hundreds
of Projects . . . Plus, Exceptional Savings

Take Any 4 Books for Only \$2⁹⁵

Values to
\$87.90

Join Now, Get A Utility Apron FREE!



1559
List \$21.95

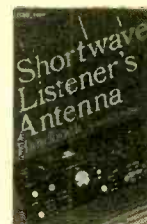

1487
List 15.95

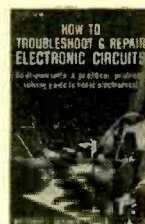

1218
List \$18.95



1183
List \$16.95



1277
List \$21.95



1685
List \$17.95



1682
List \$14.95



800
List \$19.50 (paper)



1542
List \$21.95



1690
List \$19.95



1531
List \$17.95



1465
List \$16.95



1650
List \$19.95



1709
List \$18.95



1536
List \$14.95



1108
List \$16.95



1625
List \$13.95 (paper)



1565
List \$16.95



1561
List \$19.50 (paper)



1811
List \$21.95



1604
List \$15.50 (paper)



1673
List \$13.95



1393
List \$14.50 (paper)



1449
List \$19.95

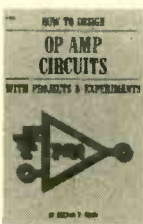

1765
List \$21.95



1605
List \$19.95



1616
List \$19.95



1679
List \$17.95



FREE Utility Apron

7 very good reasons to join the Electronics Book Club

- **Big Savings.** Save 20% to 75% on books sure to increase your electronics know-how
- **No-Risk Guarantee.** All books returnable within 10 days without obligation
- **Club News Bulletins.** All about current selections—mains, alternates, extras—plus bonus offers. Comes 13 times a year with hundreds of up-to-the-minute titles to pick from
- **Automatic Order.** Do nothing and the Main selection will be shipped automatically! But . . . if you want an Alternate selection—or no books at all—we'll follow the instructions you give on the reply form provided with every News Bulletin
- **Bonus Books.** Immediately get a Dividend Certificate with every book purchased and qualify for big discounts of 60% to 80%
- **Extra Bonuses.** Take advantage of added-value promotions, plus special discounts
- **Exceptional Quality.** All books are first-rate publisher's editions selected by our Editorial Board and filled with useful up-to-the-minute information



ELECTRONICS BOOK CLUB

P.O. Box 10
Blue Ridge Summit, PA 17214

Please accept my membership in the Electronics Book Club and send the 4 volumes circled below, plus, my FREE utility apron billing me \$2.95 plus shipping and handling charges. If not satisfied, I may return the books within ten days without obligation and have my membership canceled. I agree to purchase 4 or more books at reduced Club prices (plus shipping/handling) during the next 12 months, and may resign any time thereafter.

800 1108 1183 1218 1277 1393 1449 1465 1487
1531 1536 1539 1542 1561 1565 1604 1605 1616 1625
1650 1673 1679 1682 1685 1690 1709 1765 1811

Name _____ Phone _____

Address _____

City _____

State _____ Zip _____

Valid for new members only. Foreign applicants will receive ordering instructions. Canada must remit in U.S. currency. This order subject to acceptance by the Electronics Book Club.

CEHB-385

WERE THE GOOD OLD DAYS REALLY GOOD?

I can remember the good old days in publishing when doing business was so much simpler than it is today. We had no word processors, web presses, Xeroxs, electronic typesetting, and the like to complicate our lives. We had a simple set of rules we followed that assured us of being successful in our publishing undertakings. One such rule was: "Never use the word 'theory' on the cover—especially not as part of the magazine's title!"

So much for rules! We broke the rules in the mid-70's when we published the first **Electronics Theory Handbook**. I reasoned that some profit may be sacrificed every so often so that a meaningful magazine could be delivered to a small audience almost like a public service broadcast you hear on radio and see on TV these days. It was a rude awakening for many of us, because we thought that if we broke the rules, the newsstand sale would be a disaster. Fortunately, the magazine reading public didn't know about the rule, so it bought what it wanted and liked. Consequently, **Electronics Theory Handbook** became a top seller in its field.

The entire publishing world has since discovered that the rules should be such that they offer to the public the best kind of magazine the public wants! The great con game of the '60s and '70s is over. All our research is now geared to what you want and how publishers can best give that to you! That's why, from its inception, **Electronics Theory Handbook** has been a winner.

To this day I continue to think that **Electronics Theory Handbook** is a public service to our readers. You seek the kind of magazine that will provide the background, and/or refresh prior learnings, so that you can best apply this knowledge in the practice of your hobby. We'll keep on doing our thing and you keep on doing yours.

Sincerely yours,

Don Gabree, Publisher

AMAZING SCIENTIFIC and ELECTRONIC DEVICES

LASER DEVICES

- LC5 BURNING CUTTING CO2 LASER \$15.00
- RUB3 RUBY LASER RAY PISTOL 15.00
- LR63 IR LASER RIFLE/PISTOL 10.00
- LG03 VISIBLE RED LASER RIFLE 10.00
- LHP/LLD LASER LIGHT XMTR/RCVR SYS 10.
- LHC2 BEGINNER simulated VISIBLE LASER 5.

SCIENTIFIC & ELECT

- TCL3 SOLID STATE TESLA COIL 35KV 6.00
- BTC3 250 THOUSAND VOLT TESLA COIL 9.00
- BTC5 1.5 MILLION VOLT TESLA COIL 15.00
- HVM3 125 THOUSAND VOLT DC SUPPLY 8.00
- IOG3 ION RAY FORCE FIELD GUN 8.00
- HEG1 MILLION WATT 500 JOULE SOURCE 10.

ULTRASONIC ACCOUSTICAL

- PPF1 PHASOR PAIN FIELD GENERATOR 15.00
- PSP3 PHASOR SHOCK WAVE PISTOL 7.00
- IPG5 POCKET PAIN FIELD GENERATOR 7.00
- RAT2 RAT AND PEST ELIMINATOR 6.00
- HT9 HIGH FREQ. LISTENING DEVICE 8.00

SECURITY & PROTECTION

- DEVI DEVASTATING DEVICES 10.00
- PPG1 PHASOR PROPERTY GUARD 15.00
- MFT1 MINI VOICE XMTR 2-3 MILE 7.00
- INF1 INFINITY TRANSMITTER 15.00
- PSW3 PHASOR BURNING STUN WAND 8.00
- PG1 PARALYZING WAND 10.00

WE STOCK ALL PARTS NECESSARY FOR CONSTRUCTION OF THE ABOVE PROJECTS.

• CATALOG CONTAINING HUNDREDS MORE OF ALL NEW AMAZING and FASCINATING PLANS. EASY TO BUILD KITS and ASSEMBLED ITEMS \$1.00. CATALOG INCLUDED FREE WITH ANY OF THE ABOVE PROJECT PLANS. SEND CASH. CHECK, MO, VISA, MC TO:

INFORMATION UNLIMITED

P.D. BDX 716, DEPT. CE AMHERST, NH 03031

WANTED: PROJECTS

How would you like to find your home-brew project in the next issue of **ELECTRONICS HOBBYIST** or in one of its sister publications? It's all up to you! Build your project for yourself—it should have a real purpose. Then, if you think it is good enough to appear in one of the Hobby Handbooks, let us know about it.

Write us a short letter describing your project. Tell us what the project does. Provide us with a schematic diagram and a few black-and-white photographs of the project—photos are important. Once we read your letter, we'll let you know, one way or the other, whether we would like to purchase your article describing the project. Send your letter to:

DON GABREE, PUBLISHER
C&E HOBBY HANDBOOKS
 300 WEST 43RD STREET
 NEW YORK, N.Y. 10036

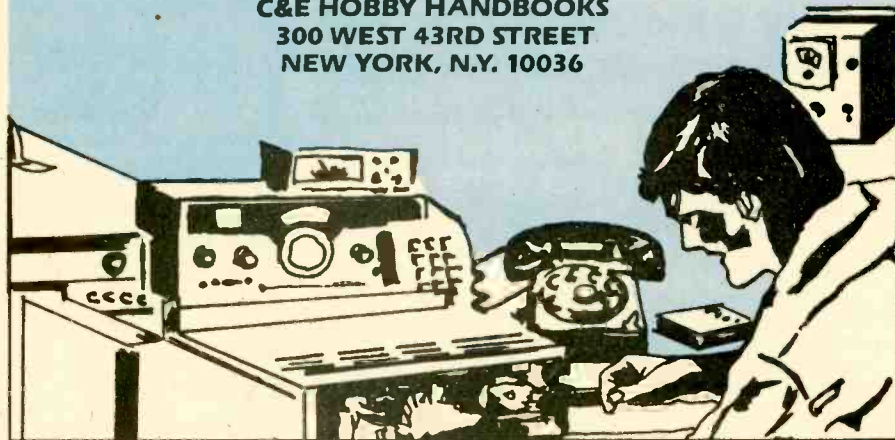

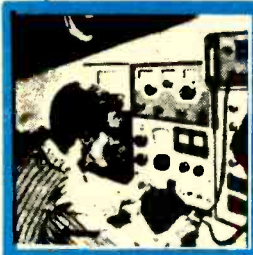

Ask Hank, He Knows!

Got a question or a problem with a project—ask Hank! Please remember that Hank's column is limited to answering specific electronic project questions that you send to him. Personal replies cannot be made. Sorry, he isn't offering a circuit design service. Write to:

Hank Scott, Editor
C & E HOBBY HANDBOOKS INC.
300 West 43rd Street
New York, N.Y. 10036

Print Out

Parents, they can drive a guy crazy! My Dad wants me to buy a Daisy-wheel printer for my computer. He says that the dot-matrix job I now have is not good enough for college reports. Mom says that I should pick up a IBM Selectric. (I prefer a new video tape deck.) What do you say, Hank?

—D.D., Brocksville, OH

Take a good look at the new electronic typewriters that are now on the marketplace. I like the Juki 2200 and others like it. The 2200 has built-in serial or parallel interface, bidirectional printing (in the computer mode, of course), automatic underline, relocate, centering, carriage return, 10-, 12-, and 15-pitch, lift-off correction, and a letter-quality Daisy wheel. The list price is \$429.00 and it's what you need. You won't have enough left over to buy a quality video tape deck, but you can stock up on raw tape!

All Fingers, No Thumbs

In the octal count, what comes after 007? And why?

—B.O., Lynchburg, VA

Imagine that you belong to a race of people who have only four fingers on each hand (easy to do if you don't count thumbs). Now, count on your fingers to nine! You can't do it unless you go back to the first finger. You know that computers start counting from zero so in order to reach 007, one must count 000, 001, 002, 003, 004, 005, and 006 first. After 007, when you run out of fingers, you jump to 010. Then you continue with 010, 011, 012, etc. In other words the numerals 8 and 9 do not exist.

Go Cellular

Is now the time to buy a cellular phone or is the price still coming down?

—V.K., Hauppauge, NY

The price will always drop—relatively speaking. By that I mean, yes, there will be some erosion of the high prices of today, but the buyers of tomorrow will see more features added to the equipment that they buy. It is always like that! However, you do have to weigh the loss of service while you wait without the cellular phone. My suggestion is to look into a lease or lease-buy deal. This way you can be taking as you ride today and trade up when a better deal shows up. Remember to read the lease's fine print very carefully.

In the Too-Fast Line

My girl is on her third speeding ticket and I suggested that she get a radar detector. Can you recommend a good buy?

—T.Y., Richardson, TX

Sure I can, but that will not help when she piles into a utility pole at 90 miles-per-hour. Why don't you kiss her good bye now (while she's still pretty), or yank free one or two spark plug wires and save her life.

Play Ball

My little league is thinking about adding FM two-way sports radios to the umpire behind the plate so that the fans can understand what is happening on the field. We have over 500 fans in the stands for some games (they donate \$2 per person) and if we can pep up the attendance figures, our league will be in great shape. Any suggestions?

—M.K., Chicago, IL

Great idea! Maybe the umps will stop those terrible sounds and say, "Ball one. Strike Two. Foul tip, count is still two strikes and 3 balls. Etc." Of course, when some of those dads pop out of the dugout, maybe the mikes should be turned off. Write to Maxon Systems, Inc., 10725 Ambassador Drive, Kansas City, MO 64153.

Still Analog

With the coming of the DMM (digital multimeter) why are they still producing those old-type "analog" multimeters—you know, the ones where the meter pointer bounces about?

—D.P., Coarsegold, CA

For the very reason that the pointer bounces about. When checking the alternator voltage against rpm as the auto's motor is accelerated, only the analog types can give you a clear picture provided you can't afford a dual pen chart recorder. Also, digital meters give reading updates every 1.5 to 2.0 seconds during which time there could be a circuit spike or dropout that will remain hidden, and with it the cause of failure for that piece of equipment. Don't give up on analog's. As for me, I'm still using the Simpson 260 which I think is the greatest analog buy on the market!

Look for the Obvious

My dot-matrix printer is not printing all the dots. The electronics is working perfectly. I have checked every circuit. What's wrong?

—K.W., Golden, CO

Oil! Did you put that one drop of quality machine oil into it that it needs? Check the printer's manual for details.

AC Theory

Hank, I am great working with several computer languages, however, I know so little about basic DC/AC theory. Any suggestions?

—D.R., Tempe, AZ

Sure enough! If you have a copy of *Electronics Theory Handbook* in your hands, you got what you need. Take a look at the abbreviated short AC course we have to offer between the covers. Better still, read it carefully and learn—that's what it's for!

New Products

SATELLITE ANTENNA

The P-611, a high performance eleven-foot satellite antenna, is designed specifically for the do-it-yourselfer and it is available in plans or kit form. Detailed assembly and instructions are included. No electronic skills or outside help are necessary. Common shop tools and basic carpentry/mechanical skills are all that's required for building the P-611 Satellite Antenna Kit #1.

The P-611 Satellite features a rot-resistant redwood perimeter frame for an aesthetically pleasing appearance; an all-steel polar mount and curve-shaping framework for strength and durability; a galvanized steel-mesh surface for reduced wind loading; and a patent-pending curve-shaping process for maximum surface accuracy.



Add a satellite receiver and a low-noise amplifier (LNA) to the P-611 antenna and you'll have an operational earth station capable of receiving over 100 television channels from orbiting satellites. The P-611 Satellite Antenna Kits sell for \$395 to \$795. The P-611 Satellite Antenna Plans sell for \$38. GFI Products Catalog is available for \$1.00. Write to Ghost Fighers, Inc., 3206 Highway 93, Stevensville, MT 59870. Tel.: 406/642-3405.

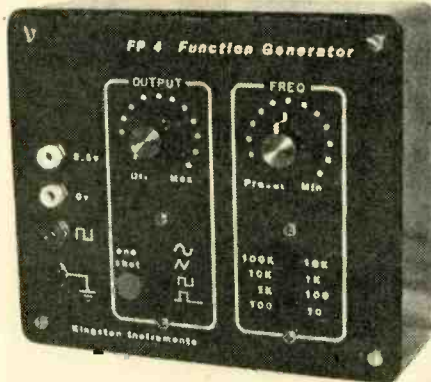

FOUR-FUNCTION GENERATOR

Kingston Instruments offers a compact function generator with a combination of features that make it useful for both analog and digital testing. The FP-4 Function Generator is \$49.95 ready to use, and is available in kit form for \$29.95.

The sinewave distortion, less than 1% THD, is unusually low for an inexpensive instrument. In addition to the usual sine, square and triangle outputs, a one-shot mode is provided which is especially useful for digital work. It delivers a single, clean pulse with each press of a front panel button. Square and pulse outputs are compatible with TTL, CMOS and most standard logic.

For more information, contact Kingston Instrument Co. 3805 Ashford Avenue, Fort Worth, Texas 76133.

SHIELDED/ENCAPSULATED AUDIO TRANSFORMERS

Santee, California—Mouser Electronics announces a line of audio transformers designed for demanding PCB applications.

Quality features make the ME429-7200 series a versatile design choice. These transformers are fully

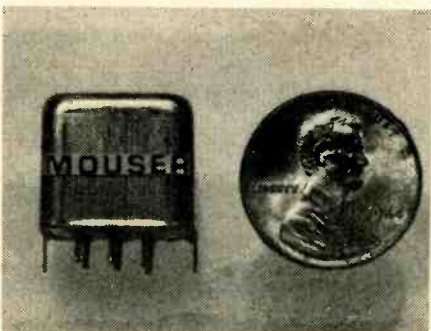

shielded to reduce spurious magnetic and electrostatic fields. The transformer body is entirely encapsulated in epoxy. This permits operation at high temperatures and keeps the PCB mounting pins securely attached to the transformer bobbin. Encapsulation also makes for stable mounting with plug-in ease. They are ideal for pulse and audio applications.

The transformers are only .65" square and .6" high. Lead spacing is .16". They are E1-14 core type and output a maximum .075 watts. Resistance ranges from 35 to 550 ohms primary, 1 to 500 ohms secondary. Stock impedances range from 500CT to 10KCT primary, 8CT to 10KCT secondary. Custom impedances are available.

They are priced as low as \$2.05 in quantities of 500.

Write or call for free catalog: MOUSER ELECTRONICS, 11433 Woodside Ave., Santee, CA. 92071 (619) 449-2222.

A P PRODUCTS ADDS NEW ALL CIRCUIT EVALUATOR

Mentor, Ohio—A P PRODUCTS INCORPORATED introduces the ACE 109, the newest and lowest priced solderless breadboard in its well-known line of All Circuit Evaluators.

Ideal for designing, testing and modifying small circuits, the ACE 109 combines the plug-in ease of 0.1" x 0.1" solderless matrix with the convenience of eight separate distribution buses of 25 tie-points each. Buses can be used for power, ground and signal lines and more.

The matrix of 840 solderless plug-in tie-points accepts DIPs of all sizes and a wide variety of discrete components with leads up to .032" in diameter. DIP capacity is up to nine 14 pins DIPs. The terminals are spring tempered copper alloy and the insulator is acetal copolymer.

Circuit elements are easily interconnected with ordinary #22 AWG

New Products

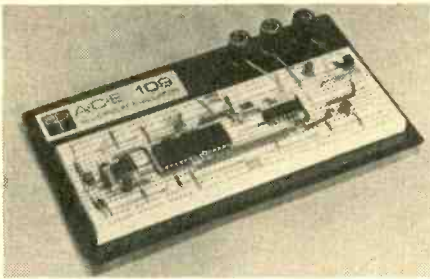

solid wire. (Or use pre-measured, pre-formed Jumper Wires by A P PRODUCTS.) The solderless braeements are permanently mounted to a metal base plate which functions as a ground plane. Connections to power supplies, signal generators or other external equipment are made via three standard 5-way binding posts attached to the base plate.

Manufacturer's suggested resale price of the ACE 109 is \$19.95.

With the addition of the ACE 109, A P now offers eight All Circuit Evaluators for fast, solderless circuit building and testing. The eight ACE's range from breadboards with 728 tie-pins and 8-16 pin DIP capacity to models with 3648 tie-points plus 36-14 pin DIP capacity.

FUSED, AC CHASSIS RECEPTACLE

Santee, California—*MOUSER ELECTRONICS* announces a new AC receptacle with built-in fuse protection.

Model 16J522 AC chassis receptacle protects your product against power surges with a built-

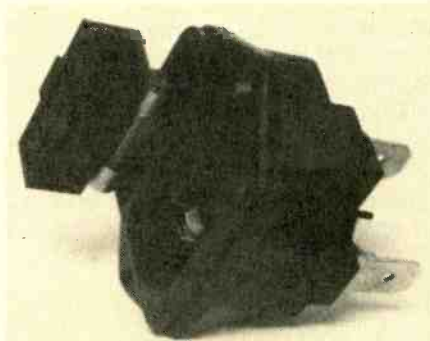

in compartment for replaceable fuses. It accepts up to a 6 amp midget (.20" x .79") fuse and, as an anti-shock safety feature, the fuse compartment cannot be accessed until the power cord is completely removed.

A locking tab snaps the fuse into contact. The receptacle features a storage space for a spare fuse and push-on terminals with a special plating for easy soldering.

The receptacle measures 1.2" x 1.1" and has molded screw brackets for secure chassis mounting. It mates to standard CEE-22, Belden 17250 and 17251, Peco C3120, Electro Cord E1015, E1024, etc.

The fused, AC receptacle costs as little as \$1.59 in quantities of 500. Write or call for FREE catalog!

WATCH SEVERAL DIFFERENT PROGRAMS ON DIFFERENT TV'S WHILE HOOKED UP TO A SINGLE ANTENNA OR CABLE!

A new electronic device called the Video Multiplier adds an exciting new dimension to the



enjoyment of viewing cassettes or video discos in the home having two or more TV sets. This compact unit is connected in minutes to the VCR, antenna (or cable) system—without tools...and it can be inconspicuously located anywhere. Hook it up and forget it!

With the Video Multiplier each member of the family can simultaneously watch the cassette or disc on his own TV set, picking it up on the UHF band—or can tune to any broadcasting channel of his choice.

The Video Multiplier transmits the same clear TV/VCR picture you now receive, does not create

interference of any kind and is fully guaranteed. It retails for only \$89.88 and is available from LENNY KACHADOORIAN, 250 Merrick Road, Box 113, Rockville Center, N.Y. 11571.

New...MINI-VAC The Powerful Micro-Cleaner With The Delicate Touch

A revolutionary new tool for Micro-Cleaning, the MINI-VAC is a lightweight, quality constructed



vacuum cleaner that is designed to remove minute particles of dust and debris from hidden and hard to reach areas. Unlike compressed air, which simply disperses the pollutants, MINI-VAC vacuums them permanently away. MINI-VAC is the tool for all reasons and seasons. It is perfect for computers, camera equipment, typewriters, stereo equipment, arts and crafts, automobiles and a hundred house uses. MINI-VAC is equipped with two interchangeable wands, two fine bristle brushes, a cloth vacuum bag, and the motor is DC powered (uses a 9-volt battery not included). It is compact, portable, versatile. Goes everywhere, gets into everything. 5" x 1 1/4" x 1 1/4". MINI-VAC is a major breakthrough in micro-cleaning! Carries a 90 day guarantee. Black and silver. 6 oz. Complete with instruction. \$29.95 plus \$2.00 each shipping and handling. USA only. The Pine Cone, Blake Building, Dept. E-84, P.O. Box 1378, Gilroy, California 95021.



BOOKMARK BY BOOKWORM

BEGINNER'S GUIDE

Discover the wonders of electrical phenomena using the exciting, hands-on projects and experiments outlined in *Beginner's Guide to Electricity and Electrical Phenomena*. The spread of topics cover everything from static electricity and magnetism to digital logic and microcomputer architecture was masterfully orchestrated by author W. Edmund Hood!

Ideal for beginners, this complete guide explores the fundamentals in an entertaining yet highly enlightening style by combining basic electronics theory with exciting hands-on projects. It's all here for the taking... from single experiments to advanced projects like a sound-powered telephone using two crystal microphones. You'll find all the projects both interesting and useful.

Find out how home wiring operates, from the fuse box to types of lighting, how digital logic works, and even what a BASIC program looks like. Exciting projects scattered throughout provide you with hands-

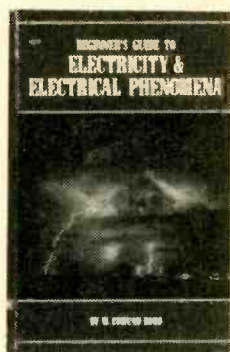

on understanding of how an electroscopes works, and how you can build one yourself; how a telephone works using a carbon microphone that you put together, and how to build a simple transformer.

This thoroughly up-to-the-minute guide is the ideal reference for students, hobbyists, do-it-yourselfers, and anyone else who wants a firm understanding of the exciting world of electricity. Published by

Tab Books, Inc., Blue Ridge Summit, PA 17214. This paperback, 250-page, book sells for \$10.25 at bookstores or direct from the publisher.

WHERE TO LISTEN

The *5th Edition* of the *Confidential Frequency List* by Oliver P. Ferrell has been greatly expanded in terms of number of frequencies and

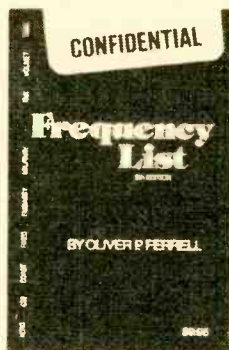

stations, and ancillary remarks. A wholly new section of the book is devoted to a reverse listing by callsign, location, service, mode and frequency. The number of details entered in the *5th Edition* exceeds 100,000 items concerning 8500 frequencies and stations. Handling this magnitude of information was only possible with the aid of a minicomputer word processor.

In the past 20 years there have been numerous changes in the use of the high frequency (HF) spectrum. Two-way HF communication has become more affordable greatly expanding the usage base. Stationary satellite relays have siphoned off a majority of the RTTY press broadcasters and many of the large radiotelephone links between continents. The text stress an apparent vulnerability in satellite communications—especially for the military and ships at sea. For your copy write to Gilfer Associates, Inc., P.O. Box 239, 52 Park Avenue, Park Ridge, NJ 07656. The softcover, 225-page book sells for \$9.95.

INSIDE DATA COMMUNICATIONS

With the title *Understanding Data Communications* and nine others in the expanded *Understanding Series*, manufacturer and publisher Texas Instruments, Inc. (one of the world's leading high-tech corporations) provides a series of books for the reader interested in today's elec-

tronics technology. The text was written by a team of writers.

Understanding Data Communications shows how digital signals are used to communicate information. In an easy-to-read style, the book explains the codes used for data communications, the types of messages, and the transmission channels, including fiber optics and satellites. The text covers how modems work and how they interface to the terminal equipment. Published by Texas Instruments Incorporated, P.O. Box 225474, M/S 8218, Dallas, TX 75265. This 272-page paperback sells for \$19.95 at better bookstores and direct from the publisher.

GETTING TO THE TROUBLE

In the new book *Handbook of Advanced Troubleshooting*, author John D. Lenk provides a practical system of advanced troubleshooting for the most common areas of electronic equipment: communications, television, and microprocessor-based systems.

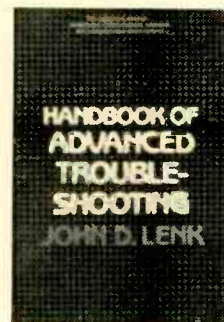

Among its features, the book: reviews basic troubleshooting techniques using the author's *universal troubleshooting approach*; shows how techniques can be applied to electronic equipment now in use as well as equipment being developed for the future; discusses a variety of test equipment for advanced service or troubleshooting; explains how operating principles or characteristics of the test equipment relate to specific problems; and includes over 175 illustrations (schematics, troubleshooting charts, and test connection diagrams) directly tied in with subject matter. Available at college and technical book stores, or directly from the publisher—Prentice-Hall, Inc., Englewood Cliff, NJ 07632. This hard cover book of 306 pages sells for \$23.95.

Solar Electricity

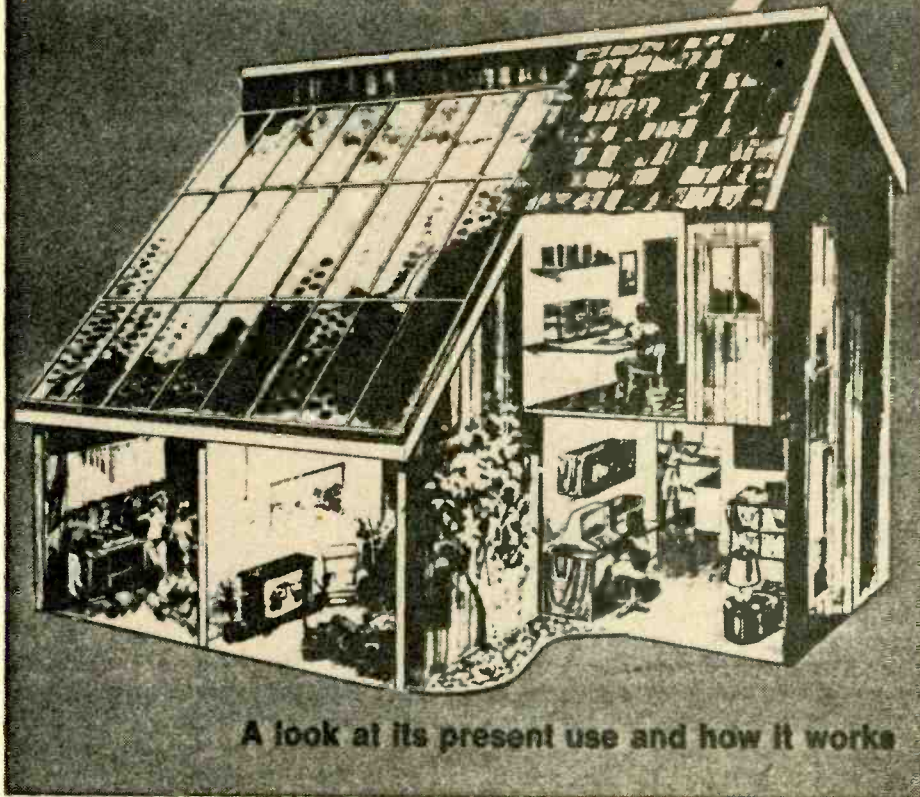

THE SOLAR CELL, or photovoltaic cell, makes a direct conversion from sunlight (solar energy) to electricity. No fossil fuel is required. Moreover, photovoltaics are safe and nonpolluting and are manufactured from materials in relatively abundant supply. Manufacturing costs are high, but declining steadily, while other methods of generating electricity involve energy costs that are rising sharply. A hope of the U. S. Department of Energy is to reduce the cost of producing electricity with photovoltaics to 50 cents per peak watt by the mid-80's. Additionally, photovoltaics require no moving parts and minimal maintenance. Associated components have a long life and no waste products are generated.

Solar Radio. Photovoltaic supplies are used extensively in the radio-communication services, such as for repeater, relay and rebroadcast stations that must be mountain-top located or located at a remote site where there is no source of power. The two-way radio services in particular can now make use of repeater sites at high locations where there is no convenient power. Weak signals from mobiles can be picked up by the receiver and then retransmitted to obtain a reliable coverage over a much larger area. High locations permit a greater separation be-

tween relay stations of a point-to-point system and more economical operation. TV and FM broadcast signals can be picked up and rebroadcast from high locations to obtain extended and better coverage into remote areas.

Radio station WBNO, Bryan, Ohio is the first AM radio station to operate with a photovoltaic power system. This project is sponsored by the U.S. Dept. of Energy and managed by the MIT Lincoln Laboratory. The solar system has a 15 kilowatt peak rating, and delivers 128-volts DC to the station. Power is supplied by 800 photovoltaic modules employing 42 cells per module. This photovoltaic power system keeps 60 lead-acid cells under charge.

Marine beacons, buoys and other navigation equipment can be powered with solar cells and associated batteries. A number of railway signaling systems are now powered with photovoltaics.

"Sun City." In another project sponsored by the U.S. Dept. of Energy, a small Papago Indian settlement has become the site of the world's first village powered by a photovoltaic power system. The village has a population of 95 and its location is 17 miles from the nearest available utility power. The solar array provides 3500 peak watts.

Basic Operation. The basic solar cell is a semiconductor diode. Most often,

Electronics Theory Handbook 1985

it is made of pure silicon properly doped to obtain a PN junction as seen in Fig. 1. The N-type silicon is doped with phosphorus, while the P-type silicon is doped with boron. The N-silicon has free electrons while the P-silicon has free-moving positive charges called holes. At the PN junction region, the charges neutralize and with no incident light, there is no charge motion.

The arrival of light-rays at the thin N-silicon layer permits a penetration of photons to the junction region. The light energy forces electrons out of the crystal structure. This motion of charges produces an output current when there is a load path connected between the positive P-silicon terminal and the negative N-silicon terminal. The current varies linearly with the amount of light striking the cell and the cross-sectional area of the cell. The absolute output current is also a function of the load resistance and the conversion efficiency of the cell.

If a solar cell is directed toward the sun at noon on a clear day, the energy striking that cell will be approximately 100 milliwatts per square centimeter. This results in maximum current as demonstrated by the top response curve of Fig. 2. Note that a light level of 100 milliwatts per square centimeter is re-

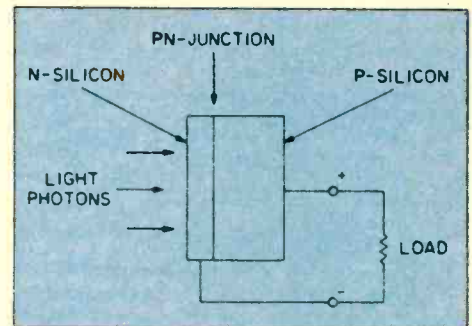

Fig. 1. A load connected between the N and P junctions will receive current flow when light photons hit the N junction.

ferred to as "1 sun." If the light level is reduced to 0.5 sun, corresponding to 50 milliwatts per square centimeter, the output current is halved.

The open circuit voltage of a silicon cell is approximately 0.57-volts. This corresponds to zero output current. When the load connected to the cell is of a resistive value that results in a

Solar Electricity

cell voltage of 0.45-volts, there is maximum power delivered to the load. As shown in Fig. 2, almost maximum current flows. A reduction in the load resistance below this value results in very little change in current. In fact, the solar cell can be short-circuited and there will be no damage or significant increase in the load current. This condition too is shown in Fig. 2, with the same current present from right above the knee of the curve over to the zero voltage value.

In practice then, the voltage produced by a single silicon solar cell is between 0.4 and 0.45-volts. The size and shape of the cell has nothing to do with this value. The level of the output current as a function of a given light intensity is related directly to the cell area regardless of the shape of the cell, be it circular, semicircular, rectangular or any other configuration. Under the illumination of 1 sun, a typical 3-inch diameter solar cell will produce an output current of 1.2 amperes at a voltage of 0.45. A similar 2¼-inch diameter cell (about half of the area of the previous one) will provide an output current of 550 milliamperes.

The efficiency of a solar cell is the ratio of the electrical power output over the light power input:

$$\% \text{ Efficiency} = \frac{\text{Power output}}{\text{Power input}} \times 100$$

Efficiency is important and determines the electrical power output that can be obtained for a cell of a given size. The

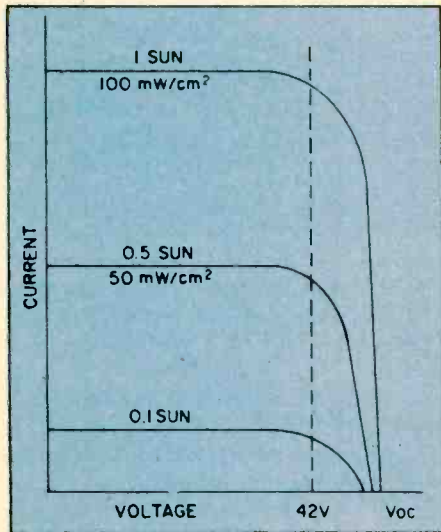

Fig. 2. Response of solar cell. Current is reduced in proportion to light intensity. One Sun yields 100 milliwatts maximum.

greater the efficiency, the more power that can be obtained with a solar panel of a given dimension. Typical efficiencies of modern silicon solar cells fall between ten and twelve percent.

Series and Parallel Connections. Higher voltage and higher current capability can be obtained with appropriate series and parallel connections of solar cells. The voltage is increased when cells are connected in series just as there is a voltage increase when batteries are connected in series. Also, there is a higher current capability when solar

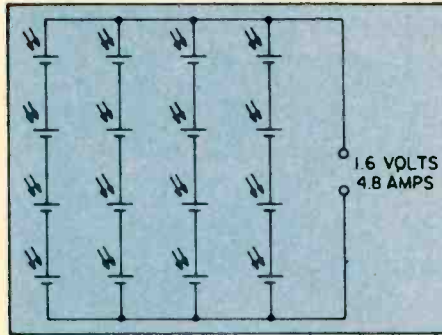
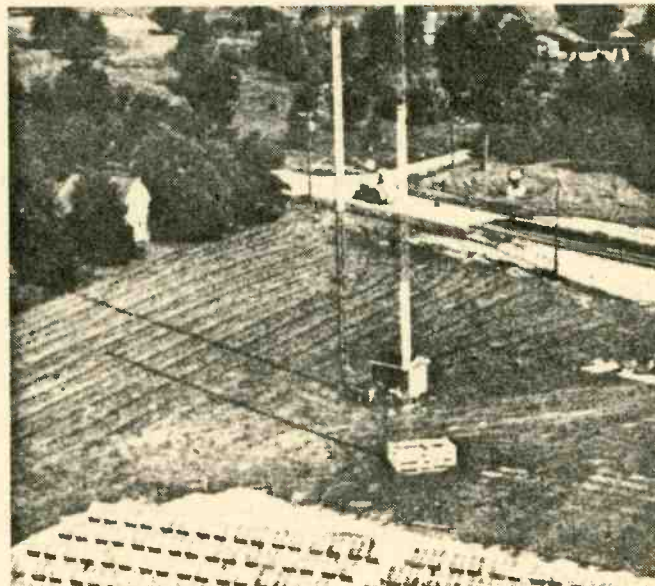

Fig. 3. Connecting solar cells in series increases voltage and in parallel increases current. Series/parallel steps up both.

cells are connected in parallel just as the current capability is increased when batteries are connected in parallel. Four, 0.4-volt solar cells connected in series will provide an output voltage of 1.6-volts (4 x 0.4). Four, 1.2 ampere cells connected in parallel will result in a current capability of 4.8 amperes (4 x 1.2). If 16 of these 0.4-volt and 1.2 amperes cells are connected in series-parallel, as shown in Fig. 3, the output will be 1.6-volts with a current capability of 4.8 amperes.

Photovoltaic Solar Panels. A solar



The transmitter of AM radio station WBNO in Bryon, Ohio is said to be the first using photovoltaic power. An array of 800 modules containing 33,600 cells produce 15 kilowatts peak and delivers 128-volts DC to the station. Sixty lead-acid cells are kept effectively charged by this system.

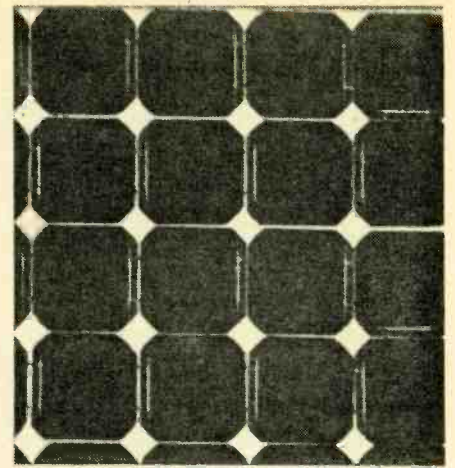

Fig. 4. Modern hi-density solar panel in frame. Model consists of sixty-four square cells producing up to 34 watts of power.

photovoltaic panel is the result when many solar cells are mounted in a series-parallel arrangement on a frame. Note that the solar panel of Fig. 4 consists of 64 square cells. The Solarex HE-51 21-inch by 21-inch solar panel provides a peak power capability of 34 watts. Its rating is 2.1 amperes at 14-volts nominal. The response of the panel is shown in Fig. 5. Based on the average insolation in the United States, the panel is capable of providing approximately 63 ampere-hours of electricity per week.

When a higher voltage is desired, panels can be connected in series just as individual solar cells. For example, two such panels in series would provide an output of 28-volts. Two of them connected in parallel would provide a current capability of 4.2 amperes.

Complete Power Supply. A complete solar power supply, including battery and load, is shown in Fig. 6. In sunlight, the solar panel charges the bat-

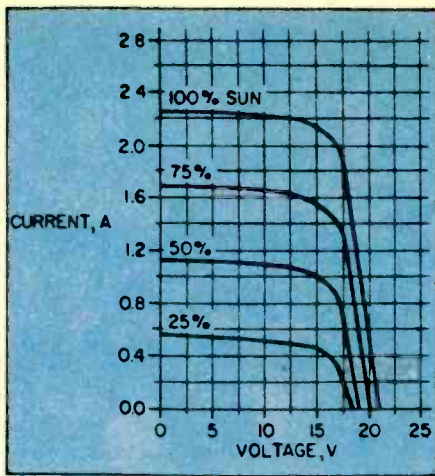
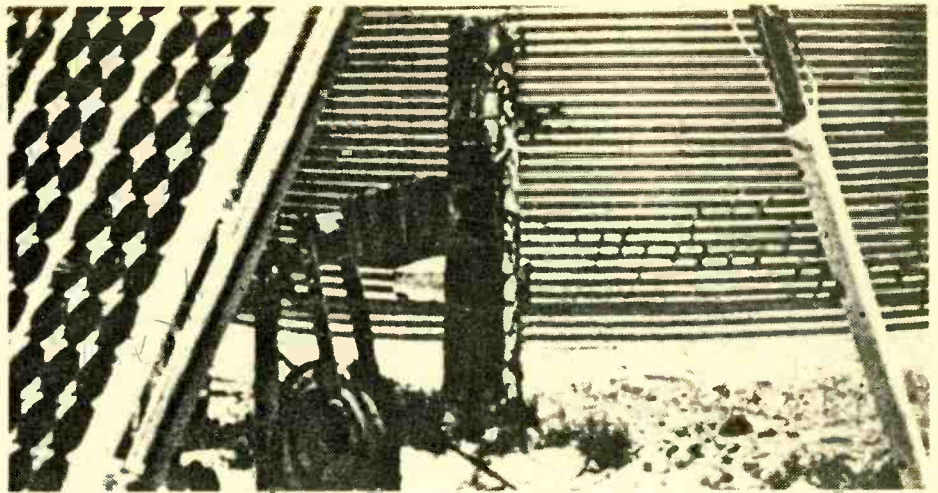

Fig. 5. A performance chart of the solar panel in Fig. 4. Note that voltage output remains at constant nominal 14-volts.



This water pump, miles from a power source, draws its electrical power from a bank of solar cells. Such pumps can transform arid deserts into arable, productive farmland.

tery through a blocking diode. The load is connected across the battery. In darkness and at low light levels, the battery supplies the necessary energy to the load on a continuous basis. Theoretically, the solar panel must be capable of supplying at least the same number of ampere-hours to the battery as the load demands from the battery. Of course, in practice, system losses and other variables require that the solar panel and battery capabilities be greater than the actual load demand.

The blocking diode is an important part of the charging system. In darkness and low illumination, the battery voltage could exceed the solar panel voltage. Without the diode in the circuit, the battery would then discharge into the solar source. Under the con-

An additional factor that must be known is the number of peak sun-hours per day for a mounting site. This information is available from appropriate charts and tables. Peak sun-hours in the southwest, for example, would be greater than along the east coast. Consequently, the ampere-hour capability would require more solar panels at a mounting site in the east as compared to one in the southwest. The average peak sun hours and the daily load in ampere-hours can be used to determine the total current in amperes that must be supplied by the solar system according to the following relationship:

$$\text{Amps} = \frac{\text{Ampere-hours per day}}{\text{Peak sun hours}}$$

As a safety margin, the amperes required should be a figure which is at least 20% greater than the above calculation. The capacity of the battery is usually made substantially greater than the above ampere-hour figure. Thus the battery should be capable of supplying the necessary power for an extended period of time, perhaps a week, assuming that illumination at the site could be low because of poor weather conditions extending over such a period of time.

A Typical Example. Assume that a radio transceiver was to be powered by a solar panel. On transmit, the current demand is 1 ampere; on receive, 0.1 ampere. Over a period of a day (24 hours) the intermittent operation of the transmitter involves a total time period of 8 hours. The receiver is in operation for the remainder of the 24 hour period. Consequently, the ampere-hours (Ah) drawn by the transmitter and receiver are:

$$\text{Transmit} = 1 \times 8 = 8 \text{ Ah}$$

$$\text{Receive} = 0.1 \times 16 = 1.6 \text{ Ah}$$

The total demand is 9.6 ampere-hours (8 + 1.6).

Assume at the site of the solar panel there are an average of 4 peak sun hours. Consequently, the current (I) that must be made available by the solar power system becomes:

$$I = \frac{\text{Ampere-hours}}{\text{Peak Sun Hours}}$$

$$I = \frac{9.6}{4}$$

$$I = 2.4 \text{ amperes}$$

Allowing a 25% safety factor, the solar system should be capable of delivering an average current I_{av} of:

$$\begin{aligned} \text{Average Current} &= \\ &= 2.4 + (0.25 \times 2.4) \end{aligned}$$

$$I_{av} = 3 \text{ amperes}$$

If the transceiver operates at 12 volts, the rating of the solar panel should be about 14-volts at 3 amperes.

In this arrangement, on an average basis, the ampere-hours delivered by the solar panel would be 12 (3 × 4), while the average demand of the transceiver would be 9.6 ampere-hours.

Conclusion. In the next decade, the photovoltaic power supply will become increasingly popular. This is especially so in the field of radiocommunications and wherever low-powered electricity is required. Further along will be the high-powered systems now costly and experimental, but with a bright future in a world of renewable energy scarcity. ■

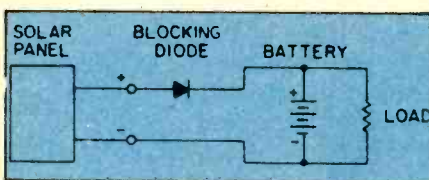

Fig. 6. Blocking diode prevents battery from discharging into solar panel when light is absent or at a very low level.

dition of high battery voltage and low charge voltage, the diode is reverse-biased. Consequently, the anode becomes more negative than the cathode and the discharge path into the panel from the battery is opened.

The solar panel must supply the total power required by the load. This it must do when sunlight is available. The battery function is to smooth out the power delivered to the load as the sunlight varies, and to supply power when the light level is low.



For years they've been saying The Robots Are Coming, and some still say so. Fact is

THE ROBOTS ARE HERE!

We call them robots if they do jobs humans used to do, or are still doing. *Robotlike* means doing a job mechanically, as though a machine were doing it.

Most people know that robots are already used in producing cars in Japan, and here in the US the major car makers are rapidly converting much of their production to include robots in their assembly lines. Industrial robots are taking over much of the drilling, welding and painting, and soon will be doing much more complicated jobs they've been developed for in other manufacturing processes all around the world.

Not only cars and kitchen appliances, but transistor radios, digital watches, and nearly all processes which involve mass production of precision appliances are now being robotized, or will be soon.

Not Man-like Machines

The robot is not a man-like machine which can do most things humans can do. Those are demonstration "robots," or sophisticated toys, or learning tools. They will be discussed in this article, but the important robots of the future (which are here today) are *programmable* machines which can do jobs formerly done by humans,

but now, or soon, are better done by machines.

In the last two years microcomputer and microprocessors, which are the heart of micros and robots have begun to outnumber human beings. That's right, there are beginning to be *more of them* than there are of *us*! I'm not talking about intelligent electronic *beings*, of course, but about obedient electronic *servants*. Most of them are small *special-purpose* computers, such as are used in automobiles for controlling ignition, microwave ovens and other appliances for controlling their operation, and of course, our own special interest, microcomputers, (micros from here on) which are desktop or smaller *general-purpose* computers, for home, business and entertainment.

By the late Eighties it's estimated that over half of all workers will in some way be involved with computers and robots either using them or working on them or designing them or fixing them. Computers will control most of the machines doing mass production, and even most service-related work. Yet by the beginning of 1984, less than ten per cent of the children in the US had taken any computer-learning classes.

In the years ahead people without some familiarity

Far from fanciful humanoids like Topo by Androbot (left, facing his Master), real robots are hard at work day and night in factories producing automobiles and appliances. More thousands are being installed every day. Above is an educational robot arm from Feedback, Inc. Armdraulic MK II 1052 has a memory of eight program sequences, each with up to 64 preprogrammed arm positions. The MK II 1052 can be controlled by remote pendant or an optional microcomputer.



with computers, at least using the keyboard to put data in, and get information out, will be in worse shape than an illiterate of the 1950s up to today. You will have to be at least slightly computer-literate in the years ahead, as jobs shift more and more to controlling the machines that do the real work.

It's estimated that there are now over a billion microcomputers world-wide, of which at least 10 million are home/business micros. As time goes on there will continue to be more and more small computers serving us in ever more ways and controlling (under our supervision) the work of production and of our daily lives.

Staying Ahead of Micros

People who are at home with computers and robots, especially how to design and/or (not how they work and how to fix them) will be in better shape to get ahead and stay ahead in the coming world. Everyone knows that things will never be the same again.

The Robot Brain

All robots have electronic brains. That is, they are run by microprocessors, which are the controlling part of

microcomputers. Generally, a robot will have a microcomputer for its brain, receiving input signals from its "eyes," its "ears," and other sensing parts, such as its sonar (distance-measuring sense).

The microprocessor is similar to, and often exactly the same as the CPU (central processing unit) of a microcomputer, which we call simply a micro. Although such a robot "brain" can be extremely sophisticated, taking in continuously-changing information from its "senses" and directing its "feet," usually wheels if it's a mobile robot, or more often its arms (most have only one).

It's brain is still much less complicated than our own brains. It works only by digital switches, millions of On and Off switching, which is *digital counting*. For an explanation of digital counting, and how computers work, see the article in this issue on How Computers Work, and also the one which explains How Computers Count.

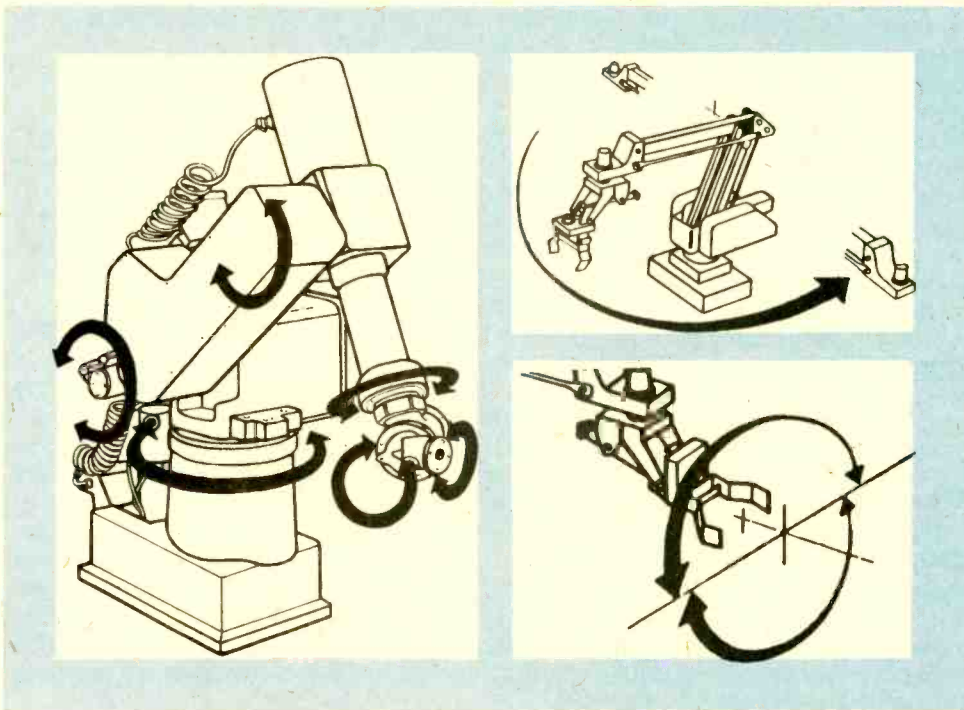

Heavy-duty industrial robot at left above for production assembly by Cincinnati Millacron shows six degrees of motion on fixed pedestal. Above top drawing illustrates wrist motions of gripping claw at end of robot "arm" while lower drawing shows how arm rotates in horizontal plane. Microprocessor in base controls arm in five axes of motion to demonstrate and teach industrial robotics in school. Apple IIe micro is used here.

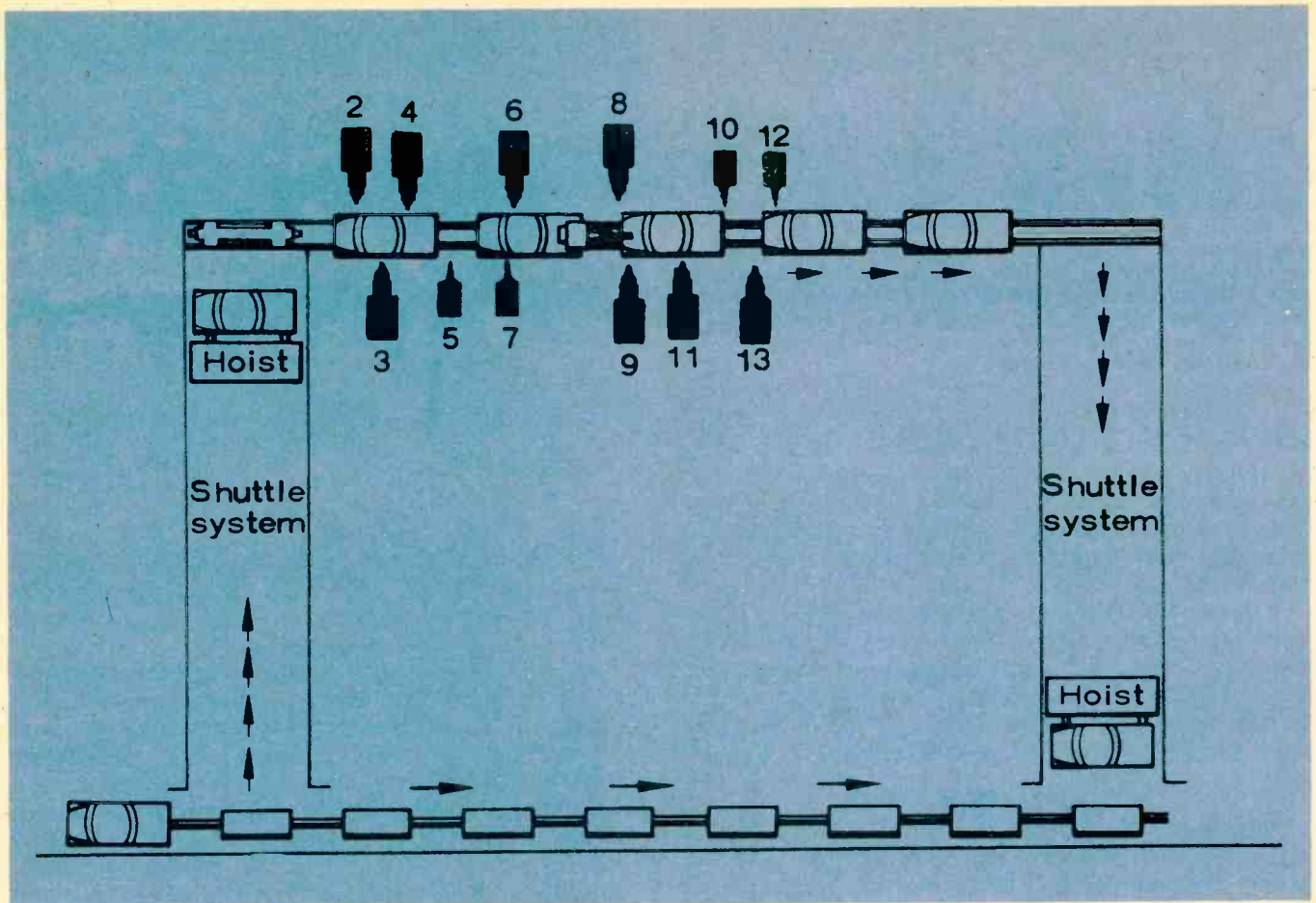

Drawing shows true (Industrial) robots on production line doing spot welding at Chrysler auto factory. Shuttle system raises units to welding position. 12 spot welders move slowly with units during actual welds. Shuttle system at right lowers welded units.

How The Brain Works

The diagram on this page shows, in simplified block form, how a microcomputer works. It's the same as the brain of a robot. It takes in information, either from its senses, or from a preprogrammed tape or other memory. It then does things depending on what the input information tell it to do. These things are most often picking something up, moving it, painting it, welding it, drilling it, and/or replacing it somewhere else.

Small industrial robots are already used widely to sort small objects, to pick them up and place them into larger assemblies, and for dozens of other dull, simple, repeated tasks. Robots can be used for any job which is repeated enough to make it pay by replacing a human's work. Some robots are already doing jobs which are dangerous for humans, and they will continue to do more and more of them.

Intelligent Robots

If a robot is to do a job which depends on varying conditions, it can receive information as shown on the second diagram. This is called self-intelligence, and is a robot of greater complexity.

Although robots can be made to move around, it will be along time before moving robots will do very complicated tasks. Most moving robots are just for demonstra-

tion, or for learning about robots and computers. One such robot is the one sold by the Heath Company (both as a kit, and factory-assembled) and described in another article in this issue.

Industrial Robots

Most of the robots in existence now, and increasing in the future, are industrial robots. They are an outgrowth of automation (automatic machines) which started in the Fifties, and became established widely in many factories in the Sixties. The programmable robot—as distinguished from a control system built into the machine itself, began to appear in the late Sixties.

Today there are more industrial robots in Japan than anywhere else. It's believed they have well above 15 thousand industrial robots at work now, with many more being added each month. The US is second, with perhaps half or more that number, steadily growing of course. Germany and Sweden are believed to have between five and eight thousand robots each, on production lines, with other countries also adding them.

The Soviet Union of course has many robots in similar applications, but it's much harder to estimate their numbers, which are believed between those of Japan and the US. These numbers are purely for industrial, useful robots, and do not include toys or learning machines.

Four Kinds of Robots

Robots already in use which can be programmed to perform particular operations fall into four groups:

- (1) Fixed-sequence robots
- (2) Variable-sequence robots
- (3) Numerical control robots
- (4) Playback robots

The last category are robots which can be taught a sequence of complicated operations by a worker who "walks" the robot through its paces. Once the operator is satisfied the robot can do the job perfectly, it's on its own; the sequence is stored in its memory and thereafter it can keep doing the task(s) as long as desired. That's usually until the robot is needed to do another job, or the job is changed to become even more complex. These are called "second-generation" robots.

More recent (third-generation) robots can be programmed to respond to changes in the situation. These are usually something which it can sense by sight or by feel; visual or tactile sensing (or both). In other words, these more sophisticated robots can detect changes in the world around them and make decisions based on that information. These decisions affect the actions of the robot.

Fixed Sequence Robots

These machines perform successive steps in a given order. Preset conditions and information are built into the robot and they are not readily changed. Such machines are barely capable of being called robots because they are designed for a specific, relatively simple operation or series of steps.

Variable Sequence Robots

These robots are similar to the above type, except that the information placed into them can be changed readily to accommodate new and different jobs.

Numerical Control Robots

The first numerical control machines (and still the most numerous) were programmable machine tools in machine shops. In these a skilled machinist teaches the programmable machine (a drill press is a simple example, or a milling machine is a more complex one) how to handle a series of operations on a piece of raw metal. After he's gone through the operation correctly the machine can do it. If it makes any slight mistakes he reprograms the memory of the machine (usually a tape) and the machine can then do it properly.

These numerical control machines are used widely, and the information they use can be on punched cards (IBM cards) as well as magnetic tapes.

Playback Robots

This is an extension of the numerical control system. The word playback suggests the tape *playing back* the sequence of operations *recorded* on it by the human operator, the "teacher."

How They Work

Industrial robots are generally fixed in place, though obviously they may be moved for new tasks. Most often they consist of an *arm* mounted on a base, with the



Robodroid (above) includes micro keyboard for programming moveable "head" which speaks and converses through speaker.

electronics (brain) in the base. The arm is capable of motion in two or more axes, up to a maximum of eight. See the diagrams showing left-right arm mobility, and rotation of the "wrist." These are two of the possible axes of motion, which are among those the human arm can make (much more easily).

The possible motions for a robot arm (and a human one) are as follows:

- (1) Arm sweep, or left-to-right movement
- (2) Shoulder up-and-down movement
- (3) Elbow extending (arm goes backward/forward)
- (4) Body turning (left/right)
- (5) Wrist up/down (pitch)
- (6) Wrist left-right (yaw)
- (7) Opening of hand (gripper)
- (8) Change direction of hand (gripper)

Many robot arms use only five or six of these motions, even so achieving a great deal of movement and complicated tasks.

The third diagram shows a modern six-axis robot which can do very involved tasks on an assembly line. Most robots, if they simply paint, or weld, or cut or drill, are much simpler of course.

What's Ahead

The programmable robot which can respond fully to changes in its environment is the ultimate robot of course. Robots who can understand spoken commands and answer "intelligently" as in the movie 2001, are on the way. But even when they appear to understand, it will only be to a limited number of commands.

GE Looking Ahead

Until now, matching robots to specific industrial tasks has been done by trial and error, requiring the creation of expensive prototype robots. Recent research and advances at the General Motors Research Laboratories have produced a computer system that can be used not only to select the right robot for the job, but also to program it to perform the job in the most efficient way.

Dozens of Kinds

There are several dozen different kinds of robots, each with different capabilities. Until now, choosing the right robot for a particular task has been mostly a manual process, involving a great deal of time and money. By combining three previously separate disciplines into a single research computer system, two General Motors scientists have made the introduction of robots, on a much larger scale than ever before, to the automobile factory a more rational, less costly job.

Roboteach

Roboteach is the name of the computer system which combines the three separate disciplines: (1) Robotics, (2) Solid Modeling, and (3) Simulation. Designed and developed by GM researchers Mary Pickett and Robert Tilove, it implements a powerful new programming language for manipulating robots. The language *specifies* robot *motions* (Robotics). However, this language cannot specify the robot's environment, its physical situation. Thus it cannot automatically account for physical obstacles, or prevent collisions.

Using only robot programming languages, actual physical testing of the robot is required to make it work in a real, physical environment.

Solid modelling, on the other hand, provides a complete representation of the physical environment (in mathematical terms). But solid modeling represents only one environment. It cannot deal with changing conditions.

While robot programming is without physical context, solid modeling is nothing but physical context. Neither by itself is adequate.

In addition to these two disciplines, the robot and its physical context must be *simulated*, in a series of discrete steps, converting the program into a series of continuous motion. Thus *simulation* is the third discipline combined with the first two into a computer program for teaching the robot its tasks.

Roboteach combines the three disciplines in a computer representation of the environment, the robot, and the task. This permits GM (and other using Roboteach) to reach decisions about the real world (robotizing a job) without the previously high expenditure of time and money, or setting the robots up ahead of time in a real, factory setting.

More Robots Coming

Not only are robots proliferating rapidly, but the tasks they will do are becoming more complex, making the need for off-line (ahead-of-time planning and programming) more urgent. When there are only half a dozen types of robots in a factory programming them by today's show-and-teach methods for each new job is possible. But when there are hundreds of robots, as is beginning to be the case at GM and other large factories, the value of being able to reprogram them without actually taking each type onto the factory floor is of enormous value, both in time and money.

Looking Ahead

Special-purpose robots will dominate production within a few decades, and ultimately be able to repair themselves. Until that time, however, people who know about computers will be needed to design, build, and repair the robots which do the work. That time is now, and any wise person entering the work force will do well to learn all he can about microcomputers, the brains of the machines of today, and even more, of the future. ■



**Here's GOOD NEWS... the up-dated
White's Radio Log is available.
Enjoy Your Radio Hobby**

**AN UP-TO-DATE DIRECTORY OF NORTH AMERICAN
AM, FM AND TV STATIONS INCLUDING A SPECIAL
SECTION ON WORLD-WIDE SHORTWAVE STATIONS**

**Only \$6.35 (ppd)
SEND FOR YOUR
COPY TODAY!**

CLIP AND MAIL COUPON TODAY TO:

WORLDWIDE PUBLICATIONS INC.

P.O. BOX #5206, NORTH BRANCH, N.J. 08876

NAME: _____
ADDRESS: _____
CITY: _____
STATE: _____ ZIP: _____

INSIDE TEST EQUIPMENT

In this section, **ELECTRONICS THEORY HANDBOOK** will describe the origins, theory and uses of two important pieces of test equipment, the **Frequency Counter** and the **Digital Multimeter (DMM)**. Both have distinct advantages over their analog counterparts and are now used widely by technicians and hobbyists in virtually every area of electronics.

The Digital Multimeter

THIS HANDBOOK, ATTEMPTS to introduce its readers to new developments in instrumentation, will now discuss advances in the measurement of voltage, current, and resistance. In the past, measurement of these parameters have utilized analog devices; however, with the advent of large scale integration semiconductor chips, a new generation of digital sampling techniques has been developed that allows accuracy to laboratory standards with moderately priced equipment. Full appreciation of the flexibility and advantages of the newer digital devices is apparent when comparison is made with analog equipment.

The relationship between current and voltage for steady state linear direct current applications is called Ohm's Law. This "Law," the most basic concept of electronics, is written

$$E = IR$$

The basic unit of voltage (E) or electromotive force is the volt. The basic unit of current (I) or time rate of change of charge is the ampere. Resistance (R) is measured in ohms.

IMPEDANCE

Things become more complex when steady state AC circuits are investigated. The units of voltage and current do not change; however, there is now a dynamic relationship between voltage and current which must take into consideration the phase angle between these two parameters. Simple DC resistance becomes a complex impedance. Impedance by definition is voltage divided by current and is the sum of the resistive

COMPONENTS AFFECTING IMPEDANCE

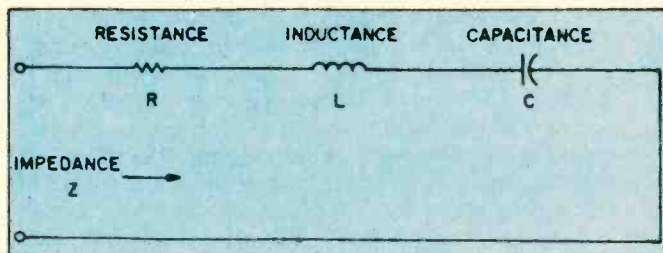

plus reactive components of the circuit. Coils and capacitors determine the magnitude of the reactance of a given circuit. It is beyond the scope of this article to deal in depth with the problem of complex impedance, but some knowledge is necessary for an understand-

ing of voltage measurements.

The DC resistance of an *ideal* capacitor is infinity. Actual capacitors have leakage dependent upon their composition, e.g. electrolytics will have much more leakage than ceramic or mica capacitors. An *ideal* inductor has zero resistance. Actual inductors have a series resistance which is a function of diameter, temperature, length, and composition of the wire used in their windings.

Under transient and AC conditions, the current flow in an inductor always *lags* the voltage flow, whereas the current in a capacitor always *leads* the voltage.

CAPACITOR CURRENT/VOLTAGE PHASING

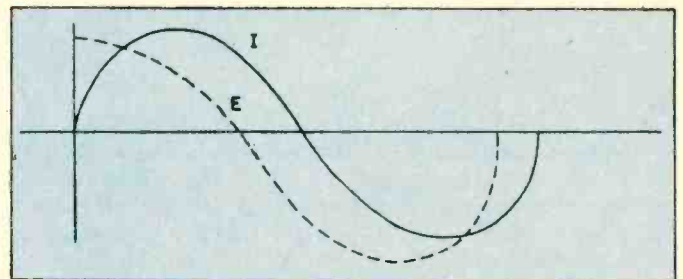

INDUCTOR CURRENT/VOLTAGE PHASING

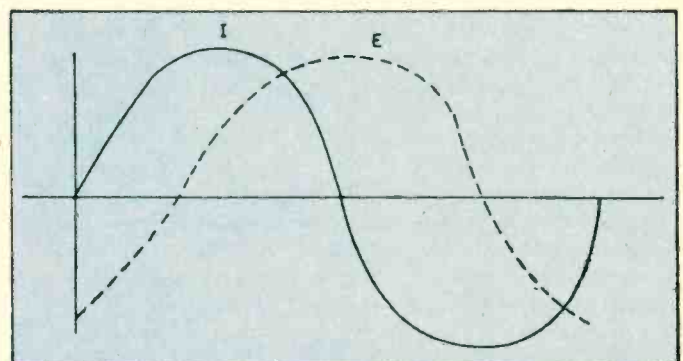

Any measurement of voltage under these conditions must take into consideration the changing nature of voltage and current flows and the impedance of the measuring device.

DESIGN CRITERIA

Certain criteria can be formulated concerning the

equipment used to measure direct or alternating currents or voltages. First, the device should be accurate and capable of measuring both AC and DC currents or voltages. Second, linearity should be present over a wide range of readings. Third, the impedance of the device should be sufficiently high so as not to "load down" the circuit being measured. Fourth, measurements of resistance should be taken at low voltages so as not to alter the resistance of complex circuits that consist of active and passive elements. Last, the readings should be reproducible and not a function of the temperature, humidity, or the supply voltages necessary to power the measuring device.

THE STONE AGE

In the past, several methods were used to accomplish these goals. For AC, high frequency, and transient measurements, the oscilloscope provided the "gold standard" for a reproducible, high quality, high

OSCILLOSCOPE MEASUREMENTS

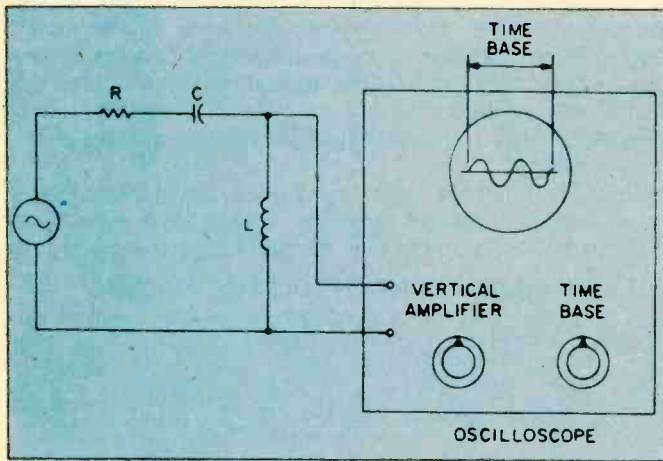

impedance device that had reasonable linearity. If the device was well calibrated, and had gain stability, measurements to two significant figures could be made over a wide range of voltages and frequencies. By use of suitable coupling devices, measurements of current could also be made. With appropriate attenuators, an oscilloscope could be made to have an input impedance of 10-megohms which was sufficient for most circuits. The phase relationship between voltage and current was easily demonstrated using dual sweep or chopped-beam oscilloscopes. Difficulties were commonly encountered with DC and very high frequency AC measurements, and with obtaining an accurate time base for the horizontal sweep circuit. Finally, the oscilloscope was not portable and proved to be a fragile device that was tied to a service bench.

Most measurements of voltage, current, and resistance not done on an oscilloscope were obtained with portable devices using D'Arsonval galvanometers called "meters." These devices, like the oscilloscope, suffered from several major faults. First, because of distortion in the magnetic field, true linearity was never achieved over the entire range of readings. Second, accuracies of only two or perhaps three significant places were available. Third, as with the oscilloscope, under certain conditions parallax (difference in reading that is dependent on the position of the observer) was a major problem. Fourth, the basic resistance of

the galvanometer was low, on the order of 20,000-40,000-ohms-per-volt for expensive equipment, and 5,000-10,000-ohms-per-volt for less costly gear. Impedances, when AC voltages were measured, were commensurately lower—on the order of 1,000-5,000

GALVANOMETER CONSTRUCTION

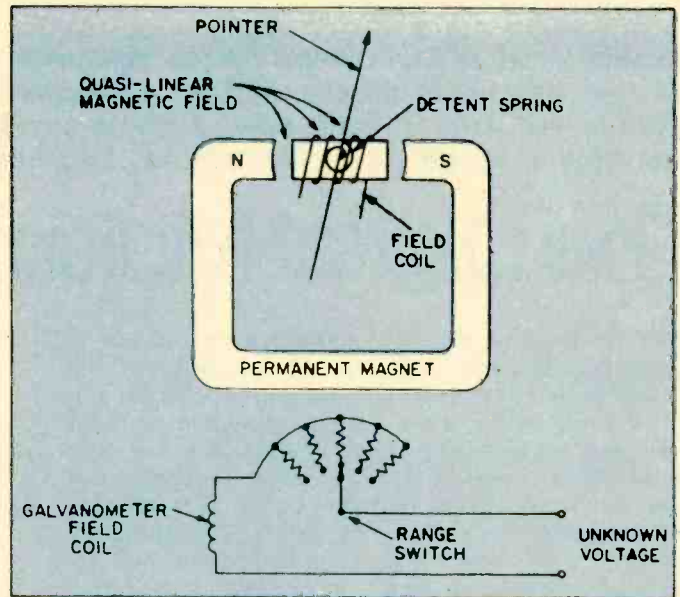

ohms. Lastly, the devices were basically fragile and easy to burn out. In spite of these shortcomings, the analog volt-ohmmeter was and is a popular, inexpensive device that sells for prices ranging from approximately \$10 to \$150, depending upon the accuracy, ranges, functions, and input resistance.

True laboratory standard accuracy—voltage readings to three and four significant places—could be obtained using D'Arsonval-type devices that operated over very narrow ranges and were used in bridge circuits that compared the unknown voltage to a known standard voltage. Unfortunately, this equipment was expensive, difficult to use, and not portable.

In another class of devices, the low basic input resistance of the galvanometer was improved by using vacuum tubes (VTVM) or semiconductor devices (eg, FET). Unfortunately, this was done at the expense of doubling the price of the equipment and adding the problem of gain stability and input offset voltages.

DIGITAL DESIGNS

With the advent of large scale integrated circuits, an alternate means of measuring voltage, current, and resistance became available. This class of devices converted the analog signal, e.g. the current, voltage, or resistance, and displayed it in digital form. Higher accuracies were obtained by expanding the scale of measurement and eliminating meter reading errors—parallax and nonlinearity. Therefore an order of magnitude advantage was obtained. For example, if a high quality volt-ohmmeter had an accuracy to 1 percent of a given reading, similar quality digital devices could be made to read to 0.1 percent accuracy. Such an advantage is obvious when analyzing complex circuitry using semiconductor components. Furthermore, the ohmmeter function of these new generation digital

INSIDE TEST EQUIPMENT

devices uses very low currents when compared to the standard volt-ohmmeter. Lastly, the input impedance of these devices is in the 10-megohm range, shunted by a small capacitor of approximately 50 pF.

Digital volt-ohmmeters are only as good as their amplifier stability and linearity, internal voltage and time references, and method of eliminating offset voltages. Various schemes have been devised to provide automatic zeroing, programmable or long term stability, and minimal offset voltages. Input signals are converted into a scaled DC voltage, which is then transformed into a digital readout by integration, logic, and display circuits. DC voltages to be measured are applied across a voltage divider. A decade fraction of this voltage is selected by the range switch. The signal

TYPICAL FUNCTION DIAGRAM

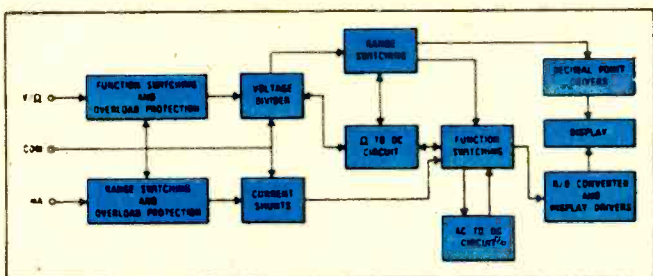

is then passed into a DC voltmeter which consists of an automatic offset correction (auto zero) circuit, a dual slope integrator, and a digital processing and multiplexing device. The reference voltage is derived from a highly stable Zener diode.

AC MEASUREMENTS

AC voltages are measured in a similar manner, except a precision shunt-resistor is used to yield a DC voltage proportional to the RMS of the unknown AC signal. A precision shunt-resistor is used to isolate the bridge circuit. Resistance measurements are made by generating a known constant current which flows across the unknown resistor. The voltage drop is applied to the buffer amplifier and the current is measured. Resistance measurements are made by passing

the unknown current through a precision shunt-resistor which develops an AC or DC voltage proportional to the current in the shunt resistor. This voltage is again applied through the bridge (for AC currents), buffer, and integrator circuits. Various degrees of auto ranging are available depending upon the design and price of the instrument. This auto ranging refinement allows wide ranges of voltage to be measured with one setting of the range selector without internal overload. Some manufacturers offer a high low ohm feature that permits in-circuit resistance measurements at voltage levels below the conduction threshold of semiconductor. The high ohm feature allows semiconductor junction tests by measurements of forward and reverse resistance ratios.

ACCURACY

As mentioned earlier, the specifications of digital multimeters are normally in the range of 0.5 percent of the reading, plus 0.1 percent of the range \pm one count for DC voltages. A display reading of 1.00-volt DC from a low impedance source will have an uncertainty of ± 0.0035 volts; a truly amazing feat. Because of the sampling nature of the device and the auto ranging features, response time is usually less than 3 seconds to within stated accuracy. Settling time for the semi-ranging devices (100 percent overvoltage) is typically 1.2 of a second.

Optimal performance can be obtained by observing

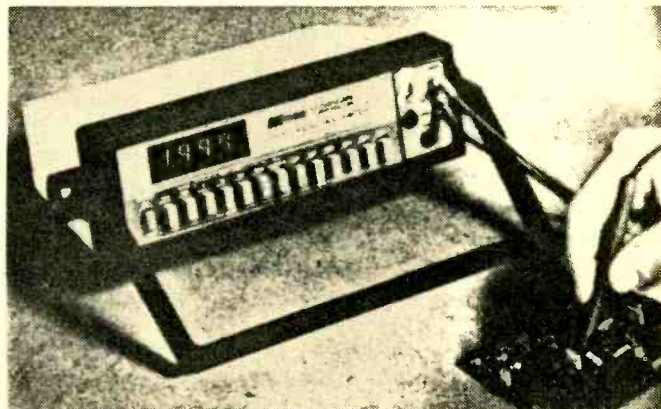

B&K Precision's model 2830 digital multimeter offers 4-place red LED readout, high/low resistance range selection, direct DC/AC current readout, a convertible carrying handle and desk prop.

Handwritten notes on a piece of paper:

50 Feb 7 - 1088
 1250
 0521
 0520
 0520
 15501

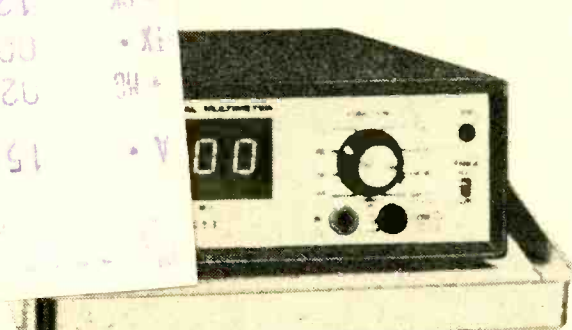

Heath's IM-2212 digital multimeter offers auto-ranging, which selects the proper voltage, current, or resistance range for more convenient measurements. It weighs 8 lbs., less optional NiCads.

a number of precautions when test measurements are made. Ground loops must be avoided since differences of ground potentials may set up loop currents and distort the measured value. Problems of this type can be almost completely eliminated by using battery operated equipment. Ground loops may be lessened by connecting the test source ground to true earth ground if possible. In floating DC or AC measurements, it is possible to introduce a common mode voltage by reactive coupling when the line cord is connected. Again, problems of this type can be almost entirely eliminated by using a battery operated meter. If only AC operation is available, this type of measurement should be made on the highest range possible consistent with usable measurement resolution. Most devices will handle up to a 100 percent full range overvoltage with meaningful readings.



An example of a handheld digital multimeter is B&K Precision's model 2815. The new LSI IC has built-in shielding against strong RF fields, making it a hot item with hams, CBers and radio techs.

The basic design features of the digital multimeter make it the ideal replacement for the existing analog multimeters and FET/VOMs or VTVMs. In addition to

providing equivalent functions and range, the inherent accuracy and features of this type of instrument provide a significant margin of improved performance over comparably priced analog meters. Digital multimeters are priced from \$60 to several hundred dollars and come in kit or assembled form. Outstanding examples of this type of instrument are the Heath model IM 2212 auto ranging digital multimeter kit, the B&K Precision 2830 3½ digit multimeter, and the new inexpensive Radio Shack model 22-197 hand-held liquid quartz 3½ digit display unit.

CONCLUSION

In summation, the proven stability of dual-slope integration combined with precision, ratio-trimmed resistor networks and advanced LSI technology has generated a series of digital multimeters that provide extreme versatility and accuracy at an affordable price. They have virtually made the hand-held galvanometer-based analog volt-ohmmeter obsolete. Their major drawback is in their time to settle on a given reading and the necessity of using sampling techniques. They are an exciting, accurate, and dependable way of making basic measurements of voltage, current, and resistance in modern electronic circuitry. ■

The Frequency Counter

THIRTY YEARS AGO FREQUENCY COUNTERS were large expensive devices reserved for colleges, the military service, and those repair facilities that had the funds to afford a counter. Most frequency measurements were done rather crudely with oscilloscopes using either Lissajous patterns or a calibrated time base sweep circuit. In any event exact frequency measurements were rarely available to the average experimenter. With the technological explosion promoted by the ever expanding consumer electronics market the need to accurately determine frequency has become apparent. Digital display of frequency or time which was once a rarity has now become commonplace.

HOW THEY WORK

The unit of frequency measurement is the Hertz. Frequency also implies time since the Hertz by definition is a cycle per second. Therefore, the period of a given frequency is defined as the reciprocal of that frequency. This can best be visualized by examining this diagram.

The simplest serial counter is one made up of two bistable devices known as "flip flops". This two bit

THE CYCLE

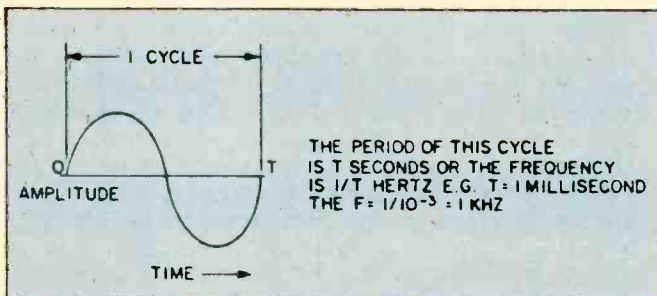

serial counter has four distinct states. It is important to note that this device counts in the binary number system. Adding an additional flip flop will yield 2^3 , or eight

GLOSSARY OF TERMS

BCD	Binary Coded Decimal
CMOS	Complementary Metal Oxide Semiconductor
DTL	Diode Transistor Logic
FET	Field Effect Transistor
FF	Flip Flop or Bistable Multivibrators
LED	Light Emitting Diodes
LSI	Large Scale Integration
RTL	Resistor-Transistor Logic
SSI	Small Scale Integration
TTL	Transistor-Transistor Logic

states, and adding N flip flops serially will yield 2^N states. Unfortunately our number system uses the base ten, not the base two. For example, the number ten in our decimal system would be 1010 in the binary or base two system. Any base ten number has an equivalent "binary coded decimal" (BCD) number.

If a precise gate interval is used in conjunction with the counter just described, frequency could be determined from the number of cycles counted during the gate period. A gate period of one second would yield a frequency equal to the number of cycles counted during this gate period. Likewise, if the gate period was .1 second, then the frequency would be 10 times the number of counts. After counting the number of pulses or counts in a gate period, some method must be devised to display and store this information until the frequency is updated during the next counting period. The scheme

INSIDE TEST EQUIPMENT

COUNTER BUILDING BLOCKS

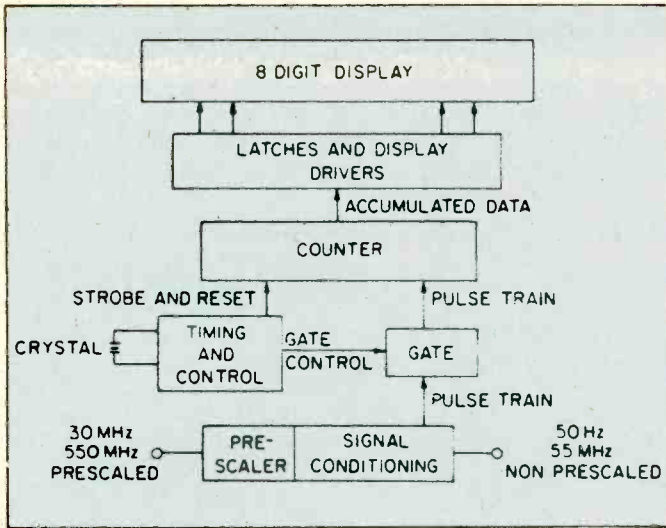

then consists of a clock oscillator which generates the gate period, a decade counter, and latch and digit driver elements plus the actual digital display.

ACCURACY

The frequency counter's accuracy is a function of its time base stability (accuracy of the gate period), which is dependent on the quality of the quartz crystal. Most counters use either the readily-available color burst TV crystals (3.579545 megahertz) or other specially designed crystals in the 4 to 10 megahertz range. To achieve a 1 part per million accuracy in the count frequency requires that the crystal oscillator have no more than 1 part per million drift over the temperature range 20 to 40 degrees centigrade (ambient temperature). Stability is achieved by pre-aging this crystal.

In the past, discrete digital elements were required in the design of a frequency counter. These sub-units were formed of "small scale integration" (SSI) building blocks of individual "diode transistor logic" (DTL) or "transistor-transistor logic" (TTL) circuits. With the advent of "large scale integration" (LSI) circuitry, it is possible not only to include a decade counter and gate within a single chip but also to place the latch circuitry and "light emitting diode" (LED) segment drivers all in one module. A typical example of such an LSI chip is the 7208 manufactured by the Intersil Corp. The maximum signal frequency which a typical LSI decade counter chip can handle is between 6 and 7 megahertz. This device is not designed to handle sinusoidal inputs as are commonly encountered during servicing applications. Also, frequencies up to 600 megahertz are now in common use.

VERY HIGH FREQUENCIES

The usefulness of a given counter chip can be extended by prescalers. A prescaler is a BCD device which counts an input frequency and divides it or prescales it to a desired output frequency. For example, if a 60 megahertz signal is to be counted by a device whose maximum frequency is in the 6 megahertz range, then a divide-by-ten circuit is necessary for useful counts to

appear. Prescalers usually are SSI devices which consist of a number of flip flops that divide the incoming frequency, "square it," and present a pulse for every tenth cycle of the original frequency. Extension of the frequency range to the 600 megahertz region can be obtained by coupling additional prescalers that are specifically designed to work at these frequencies. Useful input impedances and high sensitivities are obtained by placing amplifiers in front of the prescaler.

The input impedance of the wide-band mid-frequency amplifier is typically 1 megohm and obtained by bipolar "field effect transistors" (FET's). Amplification is then achieved by a broad band multi-stage receiver that commonly has a Schmidt trigger to "square up" the output.

The advantage of high input impedance in this fre-

PRESCALER AMPLIFIERS

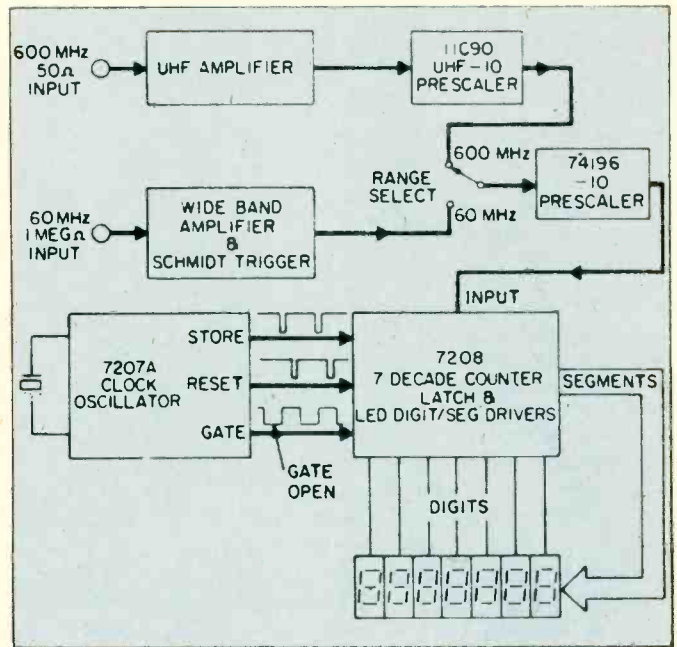

quency range is quite evident, since most harmonic oscillators will cease to operate or shift frequencies when loaded by a few thousand ohms. UHF prescalers have reasonable sensitivity without pre-amplification but again some means of impedance matching must be obtained. This is commonly done with a high frequency RF transistor and special UHF techniques to keep self inductance at a minimum and prevent possible attenuation. High input impedance in the UHF/VHF range is not desirable since the reactance of shunt capacitance is present in coaxial input cables, jacks, and various leads. Therefore, a nominal input impedance of 50 ohms is used for counting in the UHF/VHF range.

CHOOSING A COUNTER

Frequency counters are available both in kit and assembled forms and, depending on the price range, various options are available including initial zero suppression, gate indicators, AC and portable DC operation, attenuators, and temperature compensation of the crystal oscillator.

Any counter will perform properly when connected to the output of a pure sine wave signal generator. In many instances, however, frequency measurements must be made on complex electrical signals. In general, a signal may have an irregular wave shape containing noise and

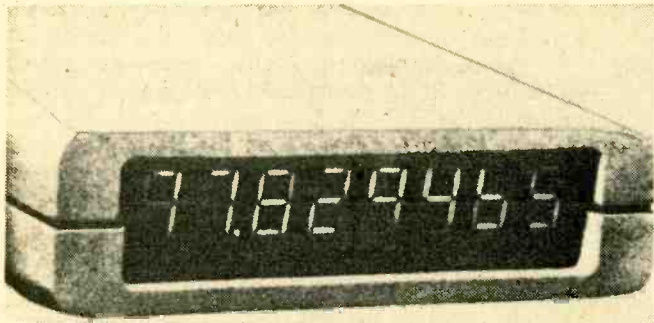

The MAX 100 from Global Specialties Corp. is a portable eight digit counter for field or lab use. Range is 20 Hz to 100 MHz.

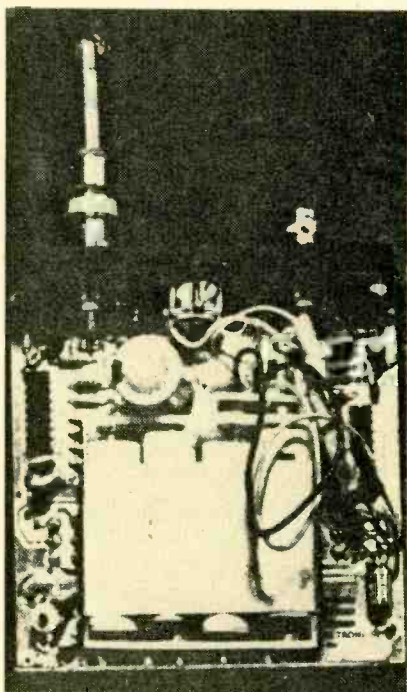

The Optoelectronics Model 7000 is a very compact Frequency Counter kit with seven digits and a resolution of 10 Hertz up to 60 Megahertz. It covers up to 550 Megahertz. This photo shows the upper side of PC board, including the battery pack. A good amount of wiring mounts on the other side of the board too.

ments can only be made with some knowledge of the counter's characteristics.

Most counters use Schmidt triggering circuits to "square up" input signals before counting takes place. Such a trigger has a hysteresis band between triggering points. Counter circuits usually trigger on the trailing edge of a square pulse.

Commonly used methods to prevent these problems consist of attenuation of the signal with significant noise, removal of dc components, increasing the signal to the counter when there is significant harmonic distortion, and eliminating ringing by the proper selection of a series damping resistor. Analyzing a few of these meth-

DERIVING SQUARE WAVES

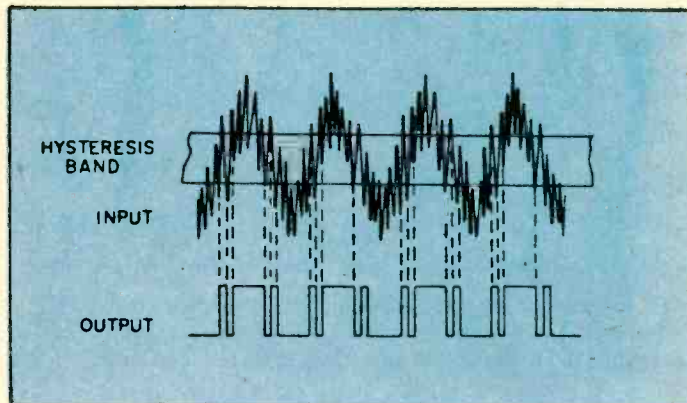

ods may prove useful in developing a practical approach to the problem of frequency measurement.

COUPLING

Let us assume that we have a signal that has ringing. This ringing will cause false triggering at every crossing of the hysteresis band as shown.

A series damping resistor which acts as a low pass filter will effectively diminish the amplitude of the ringing while leaving the basic frequency of the fundamental component unchanged.

The effect of such a series damping resistor can be analyzed as follows: for frequencies less than 60 megahertz, most counters have an input impedance of approximately one megohm and require a 10 millivolt signal for a consistent count.

The easiest method of coupling an unknown signal to the counter is by means of a short length coaxial cable. A 2½-foot length of coaxial cable has a shunting capacity of approximately 80 picofarads. The input capacitance of most counters is approximately 20 picofarads. Since these two capacitances are in parallel, the total capacitance seen by an external load is approximately 100 picofarads. A simple resistance in series with the coaxial cable will form a voltage divider. The voltage across the shunt capacitance would be equal to:

$$V_{\text{counter}} = V_{\text{signal}} / (R_{\text{Damping}} / WC + 1) \text{ where } W = 2\pi f$$

Maintaining a voltage of approximately 10 millivolts across the input of the counter will then require a damping resistance of the order of

$$R_{\text{Damping}} = V_{\text{signal}} / WC \times 10^2 \text{ if } V_{\text{signal}} \gg 10^{-2} \text{ Volts}$$

harmonics. It may also be combined with higher and/or lower frequency signals of reduced amplitude. When noise spikes and interference are present, the count may appear unstable and a significant amount of error can result. Noise or interference therefore can be seen by the counter as a signal and an erroneous reading may occur.

THE WRONG NUMBERS

Some inexpensive frequency counters have a remarkable tendency to display totally inaccurate counts that are both stable and reproducible. This condition can occur when the input signal level is just below the counter's sensitivity threshold. The counter's input amplifier tries to amplify and convert this low level signal into a countable square wave. Unfortunately there may be no indication when this condition occurs because the frequency displayed can be higher, lower, or fairly close to the actual frequency. Some high priced counters have a feature called clean drop-out, where all zeroes are displayed whenever the input signal is less than the counter's sensitivity threshold. Special precautions must therefore be taken when using inexpensive counters and measuring complex signals that are at or just above the threshold sensitivity. Accurate measure-

INSIDE TEST EQUIPMENT

A good compromise is to place a ten thousand ohm resistor in series with the coaxial cable for adequate damping of most signals.

When signals in the audio range are analyzed, a more elegant low pass filter should be placed in series with the probe. A two-stage filter with a 12 dB per octave final band pass attenuation is seen in the next figure.

LOW PASS PROBE

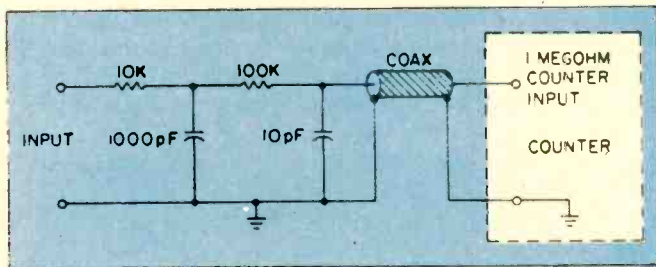

Here, the two cut-off frequencies are arbitrarily chosen at 10 kilohertz and 100 kilohertz and may be changed by varying the resistor-capacitor combinations of (R_1 , C_1) and (R_2 , C_2).

RF measurements in the high frequency to ultra high frequency range can be accomplished either through use of small whips, "rubber duck" antennas, or more elaborate coupling techniques. Feed-through terminators such as the Heath SU 511500 or Hewlett-Packard 10100-C are specifically designed to couple a counter to an RF source. A home brew RF coupling technique is shown in the following diagram.

RF PROBE CIRCUIT

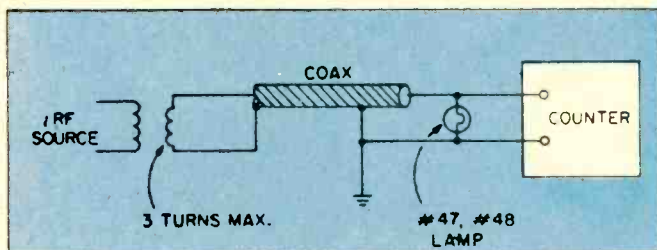

Three turns of number 18 gauge wire is fed by a suitable length of coaxial cable that is terminated in a number 47 lamp. This lamp will act as a 50 ohm termination for the coax. Such a scheme will work at the counter's one megohm or 50 ohm input impedance sources.

PUTTING THEM TO WORK

Now let's look at a couple of practical applications of frequency counter techniques. You are a licensed technician and a citizen's band transceiver is brought to you because of claimed frequency deviation from the desired channels. All frequencies have been found to be in error by the user. The frequency counter can make your trouble shooting much easier.

First, using an RF probe and having the transmitter keyed, the frequencies of the various channels can be measured. If an error exists and the channels are 10

kilohertz apart, then the problem is not in the dividing circuit of the phase lock loop circuitry but rather in one of the harmonic oscillators. On the other hand, if the frequencies are not ten kilohertz apart, the problem is in the phase lock loop circuitry.

The proper probe for measuring the frequency of an oscillator consists of a voltage divider formed of two capacitors. If one uses a high impedance probe directly, the oscillator may be loaded down and a false reading obtained. As we have discussed, 10 millivolts are required for accurate counting. Since the impedance of a 2½-foot long piece of 52-ohm coaxial cable combined with the input capacitance or shunting capacitance of the counter is a total of 100 picofarads, a 5 picofarad series capacitor will form a 1/20th voltage divider which should convert each volt of oscillator signal to a 50-millivolt signal across the input of the frequency counter.

If the problem is with the balanced mixer circuit, and the first IF frequency of the transceiver is known, the balanced mixer oscillator should be adjusted accurately to this frequency. If the problem is with the phase loop oscillator, then the reference oscillator should be checked and adjusted. By using these techniques, accurate frequency alignment can be made within 60 hertz with commonly available counters and 6 hertz in counters with temperature control units.

Another application would be to measure the frequency response of an audio amplifier. With a suitable low pass filter installed in series with the input probe, an inexpensive audio oscillator can be made of a pair of moderately priced operational amplifiers. The RC oscillator need not be calibrated since the frequency counter will serve as the reference for your measurements. A simple audio volt meter can then be used to measure the amplitude variation as a function of frequency. The frequency counter therefore has allowed an inexpensive device to become a very accurate frequency generator.

Similar technique can be used to calibrate AM and FM receivers. Low cost oscillators can be made from UHF and VHF transistors or TTL circuitry. The output of these inexpensive RF sources is then fed into the frequency counter and circuit to be aligned. The accuracy of these frequencies is determined by the accuracy of the frequency counter. IF and RF frequency circuits can be aligned by monitoring the AGC voltage, audio output, or signal strength on the output meter of the receiver. This technique can also be used to evaluate and adjust sonar, depth finders, and fish finders. From the above discussion, it is clear that any inexpensive signal generator becomes a precision piece of equipment when it is used in conjunction with a frequency counter.

Frequency counters may also be used as signal detectors. Present day state-of-the-art devices have sensitivities in the order of 10 millivolts for signals of from six hertz to sixty megahertz. Therefore, they may be used to detect strong sources of RF radiation, trouble shoot individual oscillators in a given complex piece of equipment, or even detect the source of unwanted, spurious, or parasitic oscillations.

Thus, it is clear that a modern portable inexpensive counter is an indispensable tool to anyone interested in electronics. Considering their capabilities, frequency counters are a splendid "buy" and in kit form within the pocket range of most hobbyists. They are accurate, stable, sensitive, and compact, and their number of uses are only limited to the imagination of their user. Creative designers and LSI circuitry have thus opened another door in the development of imaginative electronics. ■

A Short Course in BASIC AC ELECTRICITY

The Editors of **Electronics Theory Handbook** present here a brief, compact course in basic AC electricity. No one basic course can be complete, but there is one that is undoubtedly the finest in existence today for those who wish to be self-taught on the subject. That course is contained within a complete major literary undertaking compacted into five volumes bearing the title ***Basic Electricity/Electronics** that is published by Howard W. Sams and Co., Inc. Those portions appearing here were taken from Volume 2—*How AC and DC Circuits Work*.

Each chapter of the original work began with a section called "What you will learn," was followed by measured doses of facts to be learned, contained therein brief questions (and answers) to reinforce what was learned, and closing paragraphs, "What you have learned," that sums up the knowledge implanted in that chapter.

In no way could we hope to copy the style and scope of these chapters in the work that appears here. Instead, we have condensed several chapters into one basic course with a quiz at the end (and answers) to present to you a portion of the basic AC electricity knowledge contained in the original work. Should the presentation style be to your liking, we suggest that you examine the entire Basic Electricity/Electronics series at a local bookstore. You could write to the book publisher directly and obtain a catalog of texts offered in which that series of volumes is included and described.

Now, to the short course that we present. Read it carefully even though you know the subject. It is an excellent refresher course, and it will reinforce your prior learnings. ■

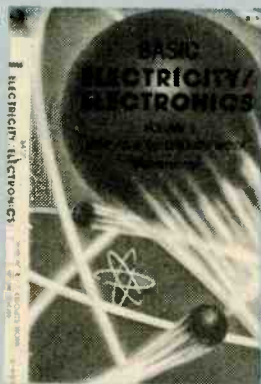

Basic Electricity/Electronics, five volumes, \$11.95 each, published by Howard W. Sams Company, Inc., 4300 West 62nd Street, Indianapolis, Indiana 46268. Available at most quality bookstores in North America.

COPYRIGHT 1981 HOWARD W. SAMS COMPANY, INC.

BASIC AC CIRCUIT

The basic AC circuit is very similar to the basic DC circuit. The only difference is that an AC generator is used as a voltage source instead of a battery. In any AC circuit, the voltage shown at the generator in *RMS* voltage. The frequency shown is in Hertz, and the resistance is in ohms.

OHM'S LAW

Ohm's law, as you learned it for DC circuits, can also be used when AC is supplied to a resistive circuit. In a basic AC circuit, all calculations will be made with *rms* voltage and current values, unless other values are specified. Ohm's law also applies to peak values, but peak values are not generally very useful. Let us look at a basic AC circuit and see what happens as the switch is closed.

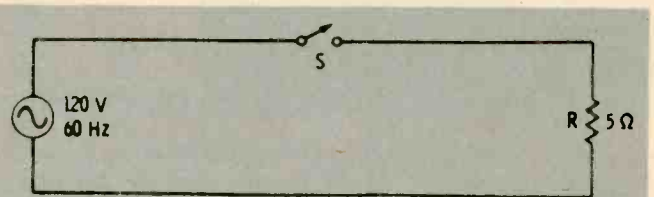

Fig. 1 An AC series circuit.

From Ohm's law, we find that the current in the above circuit will be $I = \frac{120}{5} = 24$ amperes. But, since this is an AC circuit, we also know that both the 120 volts and the 24 amperes are *rms* values; that is, they are the working values. Since AC voltage and currents appear as sinewaves, the voltage actually varies. The current also varies. See Fig. 2.

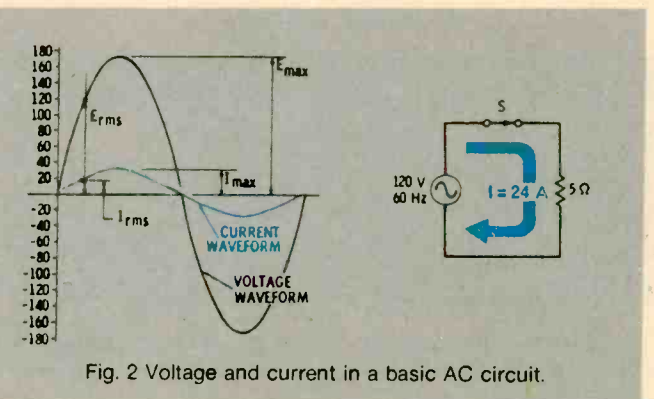

Fig. 2 Voltage and current in a basic AC circuit.

PHASE

When both the voltage and the current rise and fall together in exactly the same fashion, they are said to be **in phase**. When they do not, they are **out of phase**.

When an AC circuit contains only pure resistance, the voltages and currents will always be **in phase**. When voltages and currents in an AC circuit are in phase, Ohm's law can be applied in the same manner as in DC circuits, provided you use the same kind of values (*rms* volts, etc.) for the voltages and currents.

POWER IN A BASIC AC CIRCUIT

Power is the work done by the current, and it is

measured in watts. In DC circuits, you have seen how power equals the voltage multiplied by the current. You also learned that the power in a resistance equals the value of the resistance multiplied by the current squared. However, voltage and current must be in phase if they are used together in an AC formula. For example, $P = E \times I$ is true only when voltage and current are in phase.

It is therefore a good idea when working with AC circuits to use only $P = I^2 R$ for finding power. When using this formula, it makes no difference whether the voltage and current are in phase or out of phase.

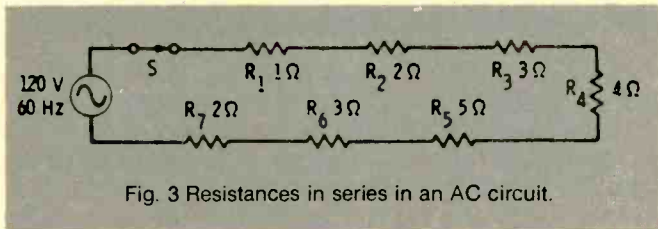

Fig. 3 Resistances in series in an AC circuit.

AC CIRCUITS WITH RESISTANCES IN SERIES

Fig. 3 is an AC circuit with its resistances in series. To find the current in this circuit, you must find the equivalent resistance of the resistors in series (the one resistance that can replace all the other resistances).

This AC series circuit can be treated in the same way as a DC series circuit. Since the resistors are all in series, the equivalent resistance is the sum of all the resistances.

$$R_{eq} = R_1 + R_2 + R_3 + R_4 + R_5 + R_6 + R_7$$

AC CIRCUITS WITH RESISTANCES IN PARALLEL

Fig. 4 is an AC circuit with its resistances in parallel. The formula and solution for the equivalent resistance of the two resistors in parallel in Fig 4 is:

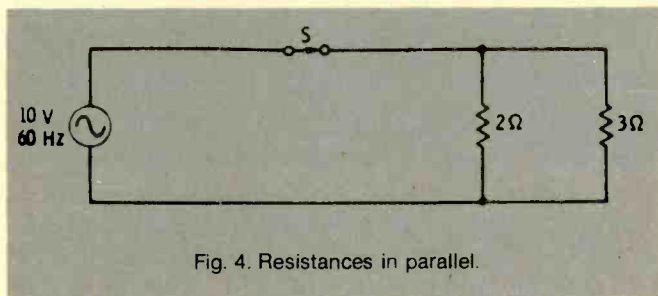

Fig. 4. Resistances in parallel.

$$R_{eq} = \frac{R_1 \times R_2}{R_1 + R_2} = \frac{2 \times 3}{2 + 3} = \frac{6}{5} = 1.2 \text{ ohms}$$

In an AC circuit with two **equal** resistances in parallel. The formula and solution for the equivalent resistance of the two **equal** resistors in parallel is:

$$R_{eq} = \frac{R_1}{2} = \frac{8}{2} = 4 \text{ Ohms.}$$

Did you notice **three** important facts about parallel resistances?

1. The equivalent resistance is always smaller than either of the parallel resistances.
2. When two parallel resistances are equal, the equivalent resistance is one half as large as either resistance.
3. Frequency does not enter into the calculations.

Combinations of resistances can be simplified one step at a time. Fig. 5 gives an example of how to simplify a combination of parallel resistances.

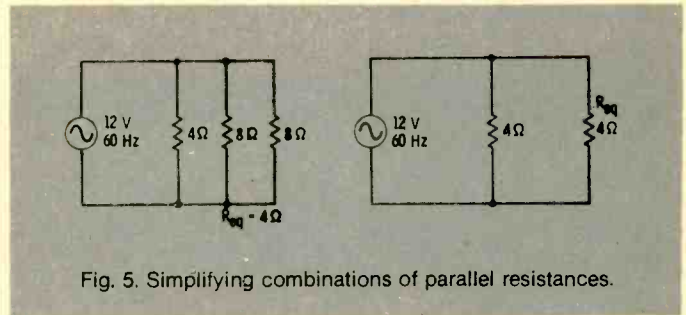

Fig. 5. Simplifying combinations of parallel resistances.

RESISTANCES IN SERIES AND PARALLEL

Now that you have learned how to handle resistors in series and pairs of resistors in parallel, it is easy to solve combinations of resistances by breaking them down into simple groups of resistors in series or pairs of resistors in parallel. Fig. 6 gives an example of how to break down a combination of series and parallel resistances.

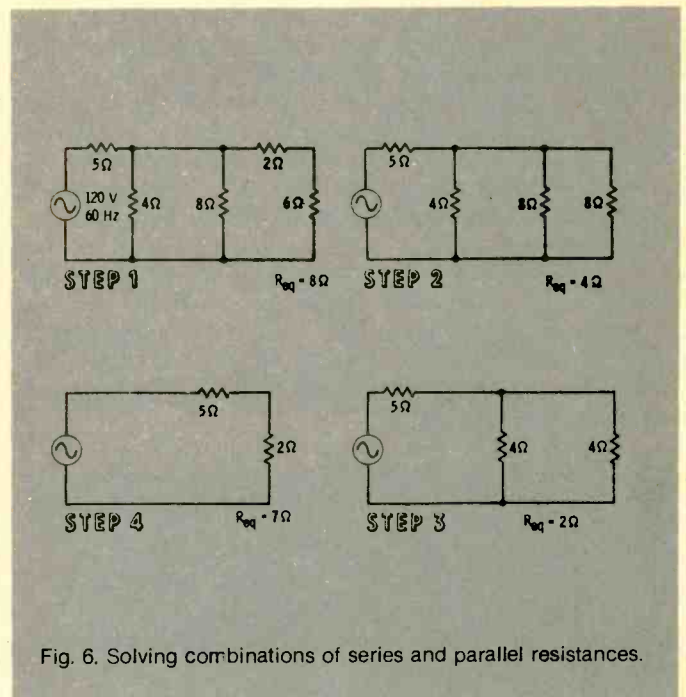

Fig. 6. Solving combinations of series and parallel resistances.

WHAT IS INDUCTANCE?

When current begins to flow in a conductor, a magnetic field builds up around it. As the magnetic field builds up, its expanding lines of force cut the conductor and generate a voltage that opposes the

increasing current. This opposing voltage, or **counter emf**, is greater when the current is changing more rapidly. In fact, the counter emf is proportional to the **rate of change** of the current, but always opposes it. When current is decreasing, the counter emf attempts to keep the current flowing.

When a sinewave current flows in an inductor (coil), the current is continually changing. Notice, in Fig. 7, that it is changing faster at the points where the sinewave crosses the zero line (points 1 and 3). It is not changing at all at the **instant** of each positive and negative peak (points 2 and 4).

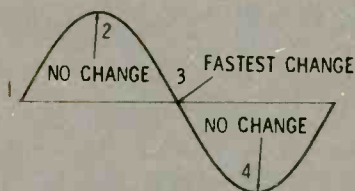

Fig. 7. Current at the peaks is steady for an instant.

The voltage in the inductor follows the rule just given. At point 1 in the illustration of Fig 8, the current is rising at its fastest rate. Therefore, the counter voltage, trying to keep the current from increasing, is at its negative peak. At point 2 on the wave, the current is not changing at all and, at this point, the counter voltage is zero. At point 3, the current is decreasing at its maximum rate, so the counter voltage, trying to keep the current from decreasing, reaches its positive peak. At point 4, the current is at its negative peak and is not changing at all. The counter voltage is zero.

We can follow the current sinewave waveform point by point and, at every instant, calculate its rate of change and the resulting counter emf. The resulting voltage waveform is another sinewave, but this one is 90° out of phase with the current. This is the waveform of the **counter emf**.

In order to keep the current flowing, and external voltage that is exactly equal but opposite to the counter emf must be applied. This is the **applied emf**, and it is 90° ahead of the current. We say that **in an inductance, the current waveform lags the applied voltage waveform by 90°**.

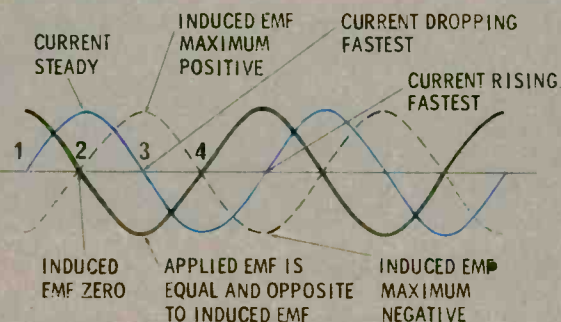

Fig. 8. Current lags the applied voltage by 90°.

In a DC circuit, inductance has an effect only when the direct current first starts to flow, and then again when you try to stop it. But, in AC circuits, the voltage is constantly changing and the inductance is constantly trying to retard the change in current. Fig. 9 illustrates the symbol for inductances.

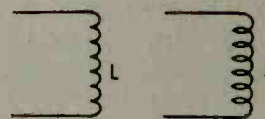

Fig. 9. Symbols for inductance.

The unit of inductance is the **Henry**. A coil is said to have an inductance of 1 Henry if the current through it, changing at a rate of 1 ampere per second, encounters an opposition, or counter voltage, of 1 volt. This means that the **opposition to current change** shows up as a voltage opposing the applied voltage. All conductors have some inductance. Straight wires have very small amounts while coils have much more. In formulas, inductance is represented by the letter **L**. A coil or inductor is indicated on diagrams by one of the symbols shown in Fig. 10.

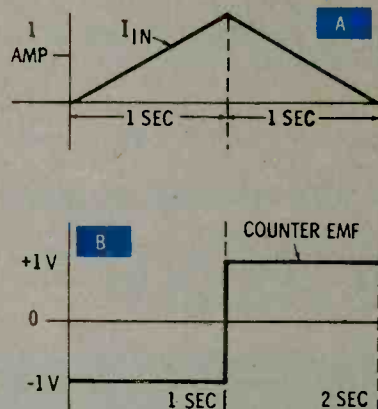

Fig. 10. Changing current produces a counter emf.

In part A of Fig. 10, with the current **increasing** at 1 ampere per second, a counter voltage of 1 volt appears and opposes the increase in current. In part B, as the current is **decreasing**, the inductive counter voltage of 1 volt is in a direction that tends to keep the current flowing. One Henry is a very large value of inductance. Therefore, inductances in milliHenrys (mH) and microHenrys (μ H) are more often found.

HOW DOES INDUCTANCE AFFECT AC CURRENT?

If a sinewave voltage is applied across a resistor, the current through the resistor also has a sinewave waveform. At every instant of the voltage waveform, the current is determined by Ohm's law and equals

E/R. The two sinewaves, voltage and current, are exactly in step; they are said to be **in phase**.

Inductance resists a change in the current. But the voltage value in a sinewave is always changing and, therefore, as always trying to change the current through an inductance. This means that inductance acts at all times in an AC circuit and **retards** the change in the current. This results in a **current wave** that is delayed after the applied voltage wave. The current wave **lags** the voltage wave by exactly 90° , or one quarter of the period of the sinewave waveform. The two waves are **out of phase** by 90° . See Fig. 11.

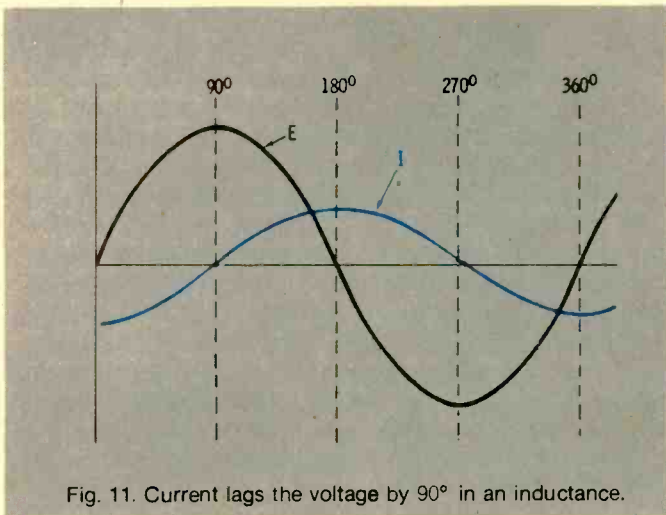

Fig. 11. Current lags the voltage by 90° in an inductance.

In a circuit containing only resistance, the voltage and current are in phase, and the voltage and current vectors have the same position. In a circuit having only inductance, the current vector is 90° behind the voltage vector (Fig.12). The length of each vector represents its magnitude.

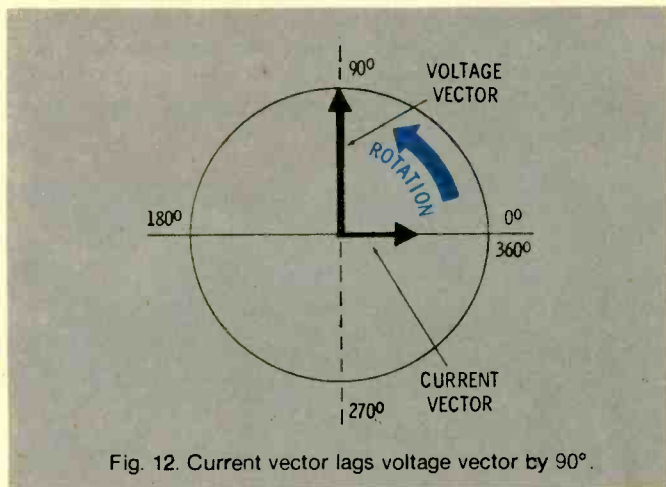

Fig. 12. Current vector lags voltage vector by 90° .

Inductance, unlike resistance, **consumes no power**. When the current in the circuit is **increasing**, inductance **takes energy out of the circuit**. It converts this energy into a magnetic field. When the current in the circuit is **decreasing**, however, this magnetic field collapses, and **all the energy returns to the circuit**. Energy is borrowed, but none is used. Refer to diagrams in Fig. 13.

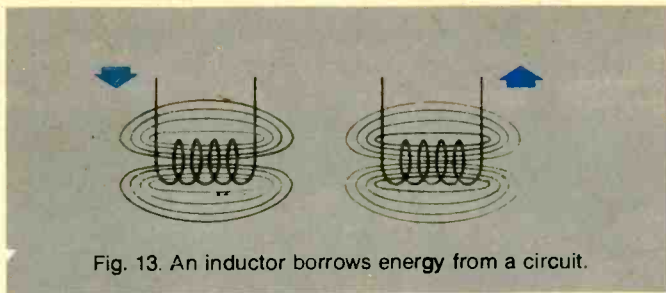

Fig. 13. An inductor borrows energy from a circuit.

FACTORS INFLUENCING INDUCTANCE VALUE

Several factors determine the amount of inductance in a coil. One of the most important factors is the number of turns in the coil. The inductance of a coil is proportional to the **square of the number of its turns**. This means that if a certain coil has twice as many turns as another coil, it will have four times as much inductance. If it has three times as many turns, it will have nine times as much inductance, etc. The diameter also affects the inductance of a coil. **The larger the diameter, the more inductance it will have.**

Placing an iron core in the center of a coil is another way to increase inductance. A coil wound on an iron rod **has much more inductance** than an air-core coil. This is because an iron core can sustain a much greater magnetic field than air and, as you have learned, the inductance of a coil is related to the amount of magnetism it can produce.

INDUCTANCE AND INDUCTION

Inductance is closely related to **induction**. Inductance is a circuit property. Induction, on the other hand, is the interaction between an electric current and a magnetic field. Whenever a current flows in a conductor, it sets up a magnetic field around the conductor. See Fig. 14.

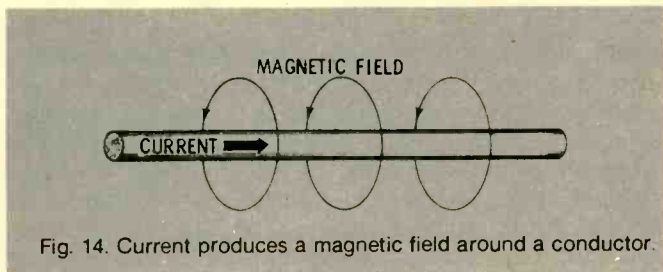

Fig. 14. Current produces a magnetic field around a conductor.

A good way to remember the direction of an induced magnetic field is the **left-hand rule**. With your left hand grasping the wire and your thumb pointing in the direction of the current, the curved fingers of your hand indicate the direction of the field. The direction of the magnetic field is always the direction toward the north-seeking pole of the magnet.

A coil with a direct current flowing through it in a particular direction acts as a magnet with a fixed polarity, just as if it were a bar magnet. When the current is AC instead of DC, the polarity of the magnetic field alternates in the same manner as the current. Conversely, if an electrical conductor is

moved through a magnetic field (Fig. 15), an electric current is **induced** in the conductor. This is the principle that causes generators to work.

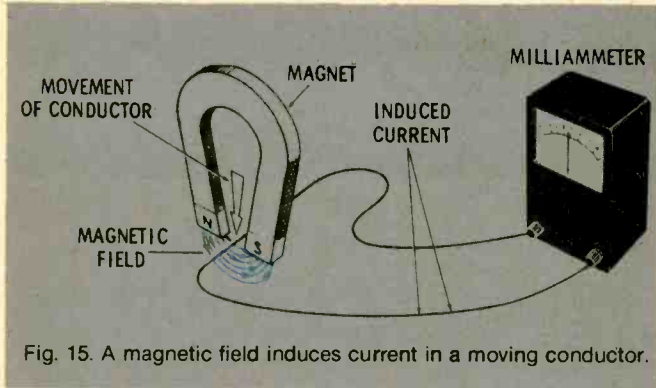

Fig. 15. A magnetic field induces current in a moving conductor.

If a coil is connected to an ammeter and a bar magnet is moved through the coil (Fig. 16), the ammeter will show that an electric current flows. This current is **induced** by the magnetic field only. If you move the bar magnet back and forth through the coil continuously, the induced current will be an alternating current. Use the lowest amperage range on the multimeter for this experiment.

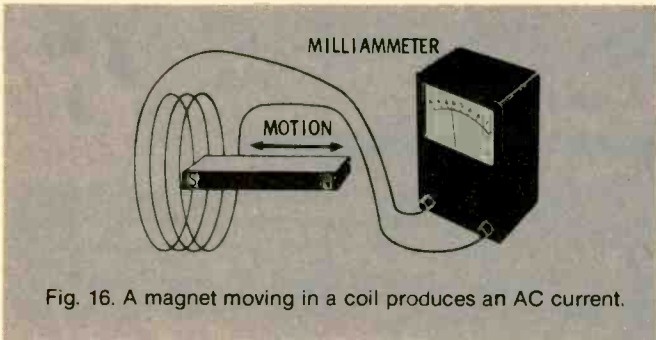

Fig. 16. A magnet moving in a coil produces an AC current.

INDUCTIVE REACTANCE

When current in an inductor is changing, inductance opposes the change by generating a counter emf. In a DC circuit, this effect is present only at the time that a switch is being closed or opened, and it dies away in a few moments. In AC circuits, however, current is constantly changing, so inductance is constantly acting to oppose it. The faster the current changes, the more opposition there will be. Obviously, the higher the frequency of a current, the faster the current will change. Inductance, therefore, tends to offer more opposition at high frequencies than at low frequencies.

In an AC circuit, this reaction to a changing current is present in addition to ordinary resistance. This opposition to the flow of an AC current through an inductor is called **inductive reactance**. The greater the inductance of the circuit, the greater is the inductive reactance. Inductive reactance does **not** oppose the flow of DC current (zero frequency). The more rapidly the current is changing, the greater the opposition, or inductive reactance, will be. Since the rate of change in the current depends on the frequency of the current,

the higher the frequency is, the greater will be the opposition to current flow.

The symbol for inductive reactance is X_L . Inductive reactance (X_L) is measured in Ohms, as resistance is (but don't confuse the two). The formula for inductive reactance is:

$$X_L = 2\pi fL$$

where,

X_L is the inductive reactance in Ohms,
 π equals 3.14,
 f is the frequency in Hertz,
 L is the inductance in Henrys.

From the formula, it is apparent that X_L increases with frequency. When the frequency is doubled, X_L doubles. Why is this? Because when the frequency is doubled, the current is reversing twice as fast, and the opposition to this change (caused by the inductance) also doubles. Notice, too, that if the frequency in the formula is equal to zero, inductive reactance disappears completely. A DC current has zero frequency and is not affected by inductance.

Inductance is very useful because every inductive circuit is **frequency sensitive**. This principle is used in filters, antennas, and many other applications. It means that an inductive circuit passes direct current and low-frequency alternating current, but it impedes the higher frequencies.

APPLICATION OF INDUCTANCE

Because inductive reactance depends on frequency, inductance is often used in **filters**. Filters are special circuits that have the property of allowing certain frequencies to pass while blocking others. There are, for example, **low-pass filters** which pass low frequencies and block high ones, and **bandpass filters** which pass only a certain band of frequencies. The following are two simple filters that depend only on inductance. The first one, which has an inductance in series, blocks high frequencies (Fig.17). It is a **low-pass filter**.

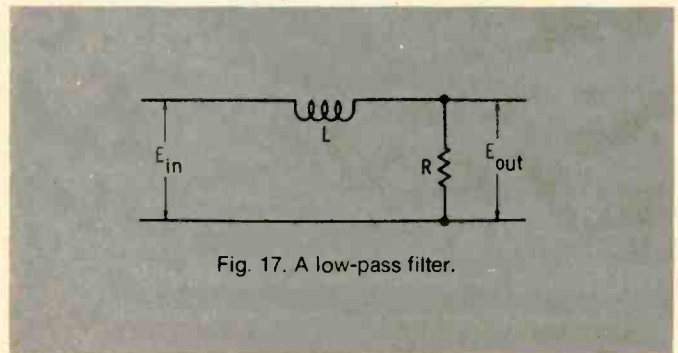

Fig. 17. A low-pass filter.

The second circuit has an inductance in parallel, or across it. This inductance will **bypass** the low frequencies (Fig. 18). As the frequency increases, voltages across the inductor increases. Therefore, there is more output voltage at high frequencies, and the circuit acts as a **high-pass filter**.

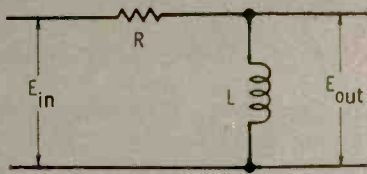

Fig. 18. A high-pass filter.

TRANSFORMERS

You are now aware that a moving magnetic field generates an electric current in a conductor, and also that current flowing in a conductor produces a magnetic field. These two effects can be combined in a circuit such as in Fig 19. One coil has a current flowing in it. It is an AC current that sets up an alternating

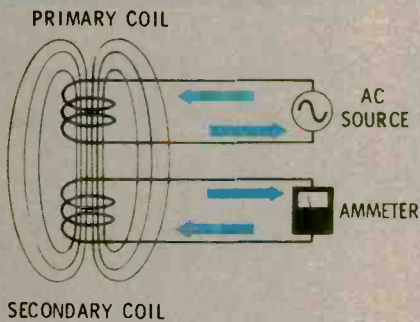

Fig. 19. The transformer principle.

magnetic field in and near the coil. If another coil is placed next to it, there will be a second alternating current induced in the second coil. The first coil is the **primary** coil, the second coil is the **secondary** coil, and the combination of the two is a **transformer**. Most commercial transformers appear as shown in Fig. 20.

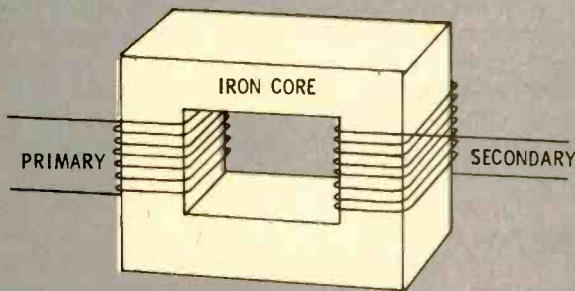

Fig. 20. Most transformers have an iron core.

An iron core is used to increase the magnetic flux and to channel it to the secondary coil. The primary coil sets up a magnetic field in the core, and the secondary coil converts the field back to electric current. Power is actually transferred from the primary to the secondary. A lamp or other load placed in the secondary circuit will operate.

One of the main advantages of using transformers is

that they can **change voltage**. They do this because the voltage induced in the secondary depends on the number of turns in the secondary as compared to the number of turns in the primary coil. If the turns in the secondary are doubled, the induced voltage will be doubled (but no more power, because the current will be halved). The **voltage ratio** of the secondary to the primary is the same as the **turns ratio**. So, if the primary of a transformer has 1000 turns and the secondary has 100 turns, it is **step-down transformer** because it steps down the primary voltage by 10 (1000/100). If the connections are reversed, it becomes a **step-up transformer** with the same ratio.

INDUCTIVE CIRCUITS

A good way to understand circuits containing inductance is to work through a simple problem. For example, the illustration in Fig. 21 shows a schematic of a basic inductive-reactance AC circuit. Assume that the resistance in the leads and the coil is negligible. The problem is to find the rms value of the current in this circuit. Ohm's Law still applies.

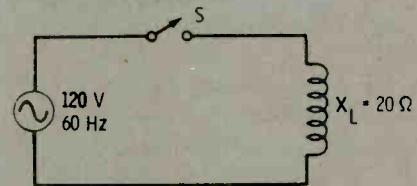

Fig. 21. A basic inductive-reactive circuit.

$$I = \frac{E}{X_L} = \frac{120}{20} = 6 \text{ amperes}$$

You have learned that power in a circuit is:

$$P = EI$$

where E is the voltage and I is the current.

With a sinewave waveform, the power at any time during the cycle is the product of the voltage and the current at that moment (Fig. 22). In a resistive circuit, power has a pulsating waveshape.

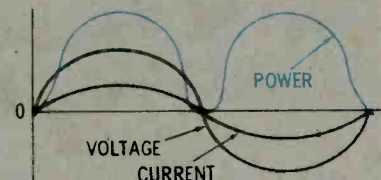

Fig. 22. Power in a resistive circuit.

You have already learned that no power is dissipated in a circuit that contains only inductance. A look at the waveforms in Fig. 23 will help you understand this. Between points B and C, both current and voltage are positive. If you multiply their values, it appears that

power is being dissipated exactly as in a resistive circuit. Between points D and E, both current and voltage are negative, and again you have exactly the same situation as in a resistive circuit—power appears to be dissipated. But, between points A and B and points C and D, there is a situation that never exists in a resistive circuit.

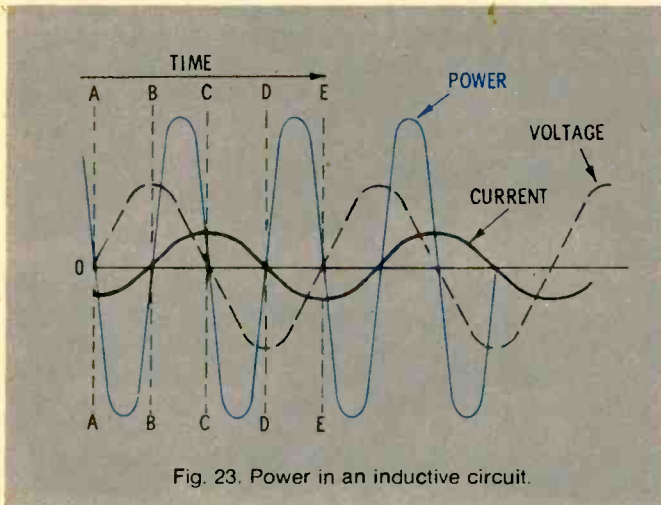

Fig. 23. Power in an inductive circuit.

As you can see, there are pulses of negative power as well as positive power. The positive-power pulses represent the time when the circuit is utilizing power to produce a magnetic field. The negative-power pulses represent the time when the circuit is absorbing power from the magnetic field. The negative pulses and the positive pulses are equal and cancel each other, so the total power dissipated is zero. Two important rules that you must remember are:

When you multiply positive values by positive values, or negative values by negative values, the results are positive values.

When you multiply positive values by negative values, the results are negative values.

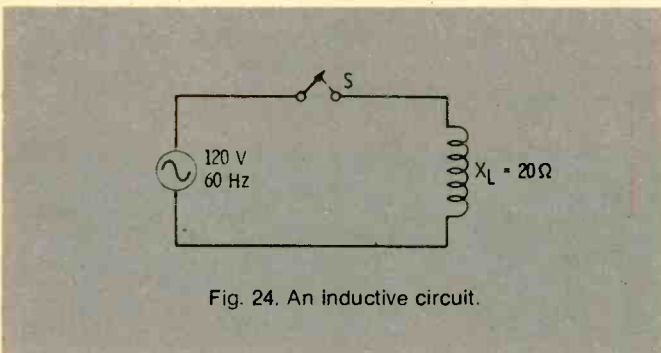

Fig. 24. An inductive circuit.

Inductive reactance in a circuit changes with frequency, but inductance stays the same. To find how the circuit in Fig. 24 behaves at other frequencies, you must determine the inductance. Use the formula:

$$L = \frac{X_L}{2\pi f} \text{ (this is a form of } X_L = 2\pi fL \text{)}$$

Inductors in Series

The simplest form of a series inductive circuit is one with two inductors in series. To find the current in the circuit of Fig. 25, and X_{L1} and X_{L2} , and then use Ohm's law with the equivalent X_L .

If the value of each inductance (L) is known, add the individual inductances to find the total inductance and then calculate X_{Leq} for the circuit.

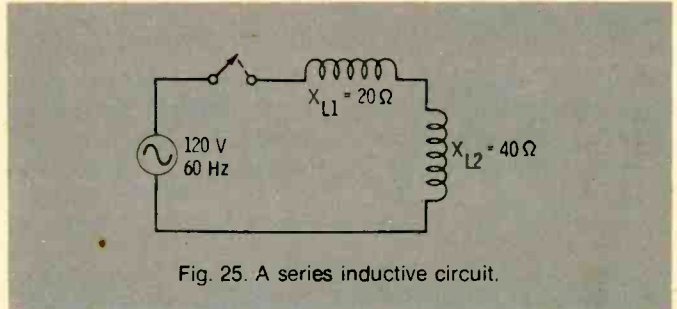

Fig. 25. A series inductive circuit.

PARALLEL INDUCTIVE CIRCUITS

A circuit containing pure inductances in parallel can be treated much like a parallel resistance circuit. The simplest parallel circuit in Fig. 26 can be solved using the formula:

$$X_{Leq} = \frac{X_{L1} \times X_{L2}}{X_{L1} + X_{L2}}$$

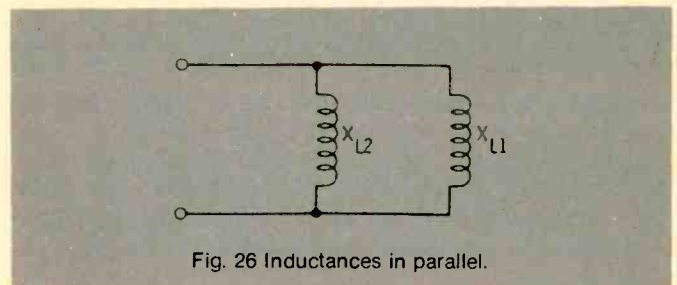

Fig. 26 Inductances in parallel.

As with resistance, the equivalent inductive reactance of two inductors in parallel is always smaller than that of either single inductor. Combined series and parallel circuits, or large groups of inductors in parallel, can be simplified in steps by using the same method that you used with resistances. Refer to Fig. 27.

Q FACTOR

An RL circuit is one that contains both resistance and inductance. You are more likely to encounter circuits of this sort than pure inductive circuits or pure resistive circuits. In fact, even the connecting conductors in a circuit have some inductance, and every coil has some resistance.

It is sometimes important to know how "good" or how "pure" the inductance of a coil is. This quality is usually measured with a factor called Q . This is simply a ratio, $Q = \frac{X_L}{R}$. With a large Q , the power loss in the coil will be small, and the inductance will be more

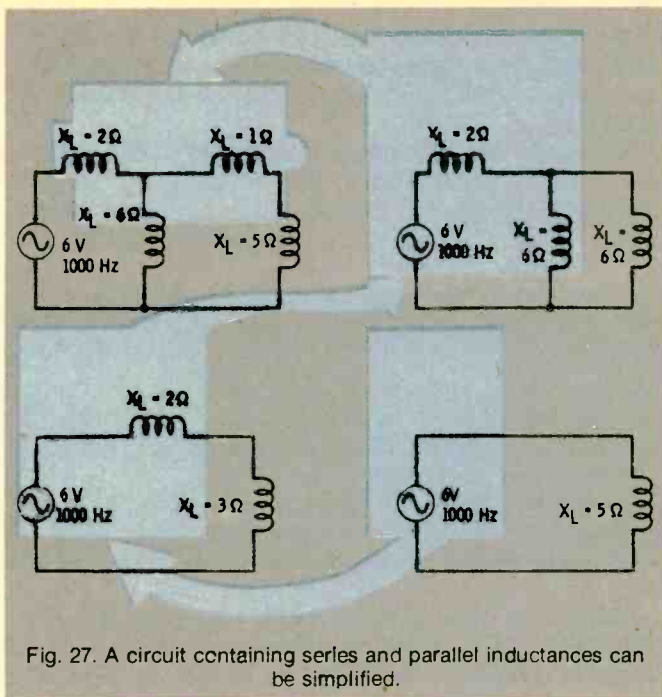

Fig. 27. A circuit containing series and parallel inductances can be simplified.

efficient. Notice, however, that Q varies with frequency, because the inductive reactance varies. For example, a coil with an X_L value of 5000 Ohms at 10,000 Hz and a DC resistance of 50 Ohms will have a Q at that frequency of 100 ($\frac{5000}{50}$). If this same coil is used at 5000 Hz, its inductive reactance will only be 2500 Ohms, and its Q will equal 50 ($\frac{2500}{50}$).

TIME CONSTANT

A different method that is used to measure the relative amounts of resistance and inductance is a very important factor when dealing with pulse circuits. The shape of a pulse is changed by inductance.

When a pulse is passed through an RL series circuit, the roundness of the current rise and the time it takes for the current to rise to its final value depend on the amounts of inductance and resistance in the circuit. As you would expect, the greater the value of inductance, the slower the current will build up. At the same time, the resistance in the circuit has the opposite effect—the smaller the resistance, the longer the current takes to reach the steady-state conditions. See Fig. 28. (The reason is that when the resistance is smaller, the final current will be larger, and it will therefore take longer to reach the final value.)

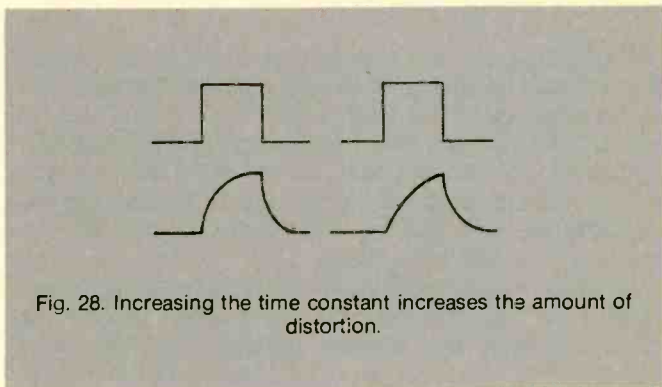

Fig. 28. Increasing the time constant increases the amount of distortion.

When dealing with filters and pulse circuits, circuits containing L and R in series are often described by their **time constant**. This is a measure of how quickly the current in the circuit reaches its final peak value. The time constant equals L/R and is expressed in seconds. If a circuit has an L/R time constant of one-half second, the current will reach 63% of its maximum (peak) value in one-half second when a voltage is applied to the circuit. See Fig. 29.

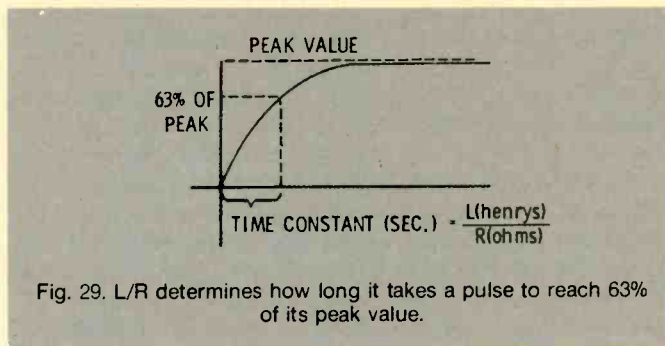

Fig. 29. L/R determines how long it takes a pulse to reach 63% of its peak value.

PHASE

It has been previously explained that AC voltage and current are always in phase in a purely resistive circuit and that AC current through an inductance always lags the applied voltage by 90° . When resistance and inductance are combined in a single circuit, the amount of phase difference between the current and voltage depends on which (resistance or inductance) has the greater value; that is, it depends on the Q of the circuit.

If the applied voltage has a sinewave waveform, the current through an RL circuit will also have a sinewave waveform. Therefore, you can think of it as being

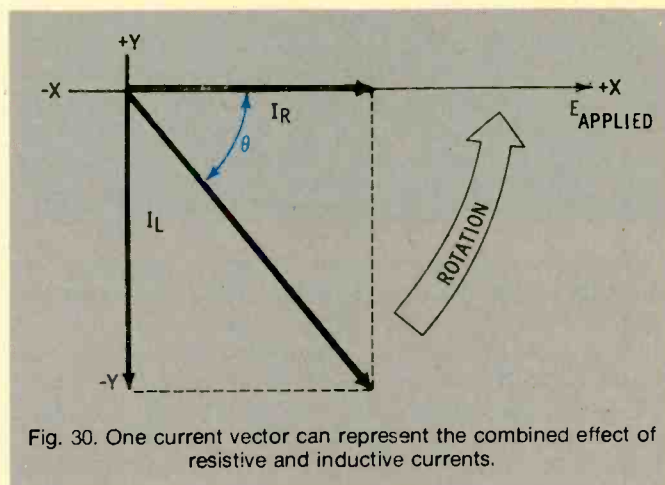

Fig. 30. One current vector can represent the combined effect of resistive and inductive currents.

generated by a rotating current vector. However, this vector is a combination (or resultant) of the resistive and inductive current vectors. As you see in Fig. 30, these two vectors form the two sides of a rectangle, and the overall (resultant) current vector is the diagonal of the rectangle. The angle labeled with the symbol θ is the **phase angle**, the number of degrees by which the overall current lags voltage.

IMPEDANCE

To find the current flowing in a purely inductive circuit, you apply Ohm's law, using inductive reactance instead of resistance ($I = E/X_L$). Inductive reactance, of course, equals $2\pi fL$ and varies with frequency and inductance.

What happens when both resistance and inductance are in series in the same circuit? Say, for example, that the resistance is 3 Ohms, and the inductive reactance (for a specific frequency) is 4 Ohms. As you know by now, the current through the resistance in an AC circuit is **in phase** with the applied voltage, while the current in the inductance **lags 90° behind** the voltage. Just as the rms value of the resistive current cannot be added to the rms value of the inductive current to find the overall current, the 3 Ohms of resistance cannot be added to the 4 Ohms of inductive reactance. Instead, the overall effect of the two must be found in the same way that the overall current vector is found. The overall effect of resistance and reactance working together is called **impedance**. The symbol for impedance is **Z**.

RELATIONSHIP OF X_L , R , AND Z

One simple way to find the overall effect of 3 Ohms of resistance and 4 Ohms of inductive reactance is to draw a line 4 units long pointing downward. This line represents the inductive reactance. Then draw a line 3 units long at right angles to the first line. This line represents the resistance. The two lines form two sides of a rectangle. The diagonal of the rectangle will represent the impedance.

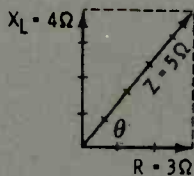

Fig. 31. Impedance can be expressed in polar form.

Notice the angle between R and X_L vectors. This angle is usually indicated by the Greek letter *theta* (θ) and is referred to as the phase angle.

It is not enough to say that a circuit has an impedance of 5 Ohms; you must also know the angle by which the current and voltage are out of phase. There are two ways to do this. You can express impedance in *polar form*, $Z \angle \theta$. In the example in Fig. 31, Z is 5. Or, you can express the impedance as the sum of 3 Ohms resistance plus 4 Ohms inductive reactance. A short way of saying this is $3 + j4$. The j tells you that the 4 is 90° ahead of the 3. In general, $Z = R + jX_L$. This is the *rectangular form* of impedance. Although you can find impedance by drawing vector diagrams and measuring, there are other ways of finding the value of impedance.

As long as θ remains the same, the proportion

between reactance and impedance will be the same. The proportion between resistance and impedance and between reactance and resistance will always be the same.

When any two facts about a combination of X_L and R are known, the other facts can be found by using a table of *trigonometric functions*. Some trigonometric relationships of X_L , R , and Z are given in Fig. 32.

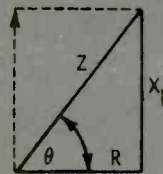

$$\begin{aligned} \tan \theta &= \frac{X_L}{R} \text{ or } R = \frac{X_L}{\tan \theta} \\ \sin \theta &= \frac{X_L}{Z} \text{ or } Z = \frac{X_L}{\sin \theta} \\ \cos \theta &= \frac{R}{Z} \text{ or } Z = \frac{R}{\cos \theta} \end{aligned}$$

Fig. 32. Trigonometric relationships.

Using the relationships shown in Fig. 32, the impedance of an inductive circuit, for which X_L is 7 Ohms and R is 10 Ohms, can be found.

$$\tan \theta = \frac{X_L}{R} = \frac{7}{10} = 0.700$$

$$\theta = 35^\circ; \sin \theta = 0.574$$

$$Z = \frac{X_L}{\sin \theta} = \frac{7}{0.574} = 12.2 \angle 35^\circ \text{ ohms}$$

(You will need a trigonometric table for this calculation.)

Determining the impedance of the circuit in Fig. 33. To do so requires the summing of resistors and inductors first.

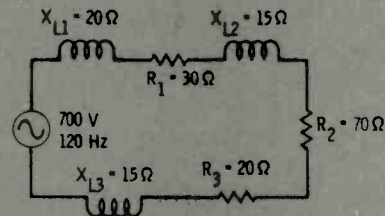

Fig. 33. Inductors and resistors connected in series in a circuit.

WHAT IS CAPACITANCE?

Capacitance is the property of an electrical circuit that **opposes a change in voltage**. Capacitance has the same reaction to the voltage that inductance has to current. This means that if the voltage applied across a circuit is increased, capacitance will resist that change. If the voltage applied to a circuit is decreased, capacitance will oppose the decrease and try to maintain the original voltage.

In a DC circuit, capacitance has an effect only when voltage is first applied, and then again when it is removed. **Note that current cannot flow through a capacitance.** However, an AC current appears to flow

through a capacitance—you will learn how later. Since voltage is constantly changing in AC circuits, capacitance acts at all times to retard these changes in voltage.

A basic capacitor (sometimes called a condenser) is shown in Fig. 34. It consists of two conducting metal plates separated by a layer of air or other insulating material, such as paper, glass, mica, oil, etc. The insulating layer is called the **dielectric**.

All capacitors have two plates and a separating layer. In practice, these are often stacked or even rolled into a compact form.

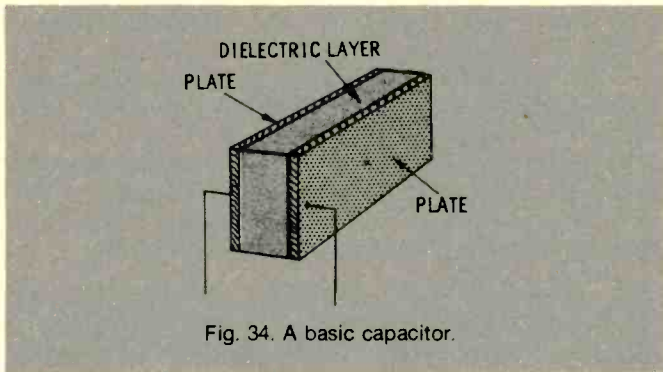

Fig. 34. A basic capacitor.

When a capacitor is first connected to a battery, electrons from the negative terminal of the battery flow to the nearest capacitor plate and remain there. They can go no farther, since the second plate is separated from the first by an insulating layer. Electrons are moved from the opposite capacitor plate and flow into the positive terminal of the battery. After this initial movement of electrons, one plate is filled with all the

and
rons.
e and
urther

er, so
f the
hat is

er of
at the
e.

nce is
e in a
s (in
p the
1 volt
rans-

e of 1
liffer-
r the
hold
lates.
micro-
or in
riated

HOW DOES CAPACITANCE AFFECT AC CURRENT?

Although current cannot flow through a capacitor, an AC current appears to do just that. The reason lies in the nature of capacitance. If the voltage across the plates is continuously varied, the number of electrons on one plate of a capacitor repels electrons from the other plate. Decreasing the number of electrons on the first plate allows electrons to be attracted back to the other plate (Fig. 35). Thus, an AC voltage can, in effect, get across the dielectric; since the voltage is alternating, it causes an AC current on the other side of the dielectric. In other words, **voltage changes** are transmitted across the gap.

If a capacitor has the same voltage as the applied voltage, no current will flow to or from it. However, if the applied voltage changes, the capacitor voltage will no longer equal the applied voltage. Current will flow trying to equalize the two voltages. In a circuit, this means that if an AC sinewave voltage is applied across a capacitor, an AC sinewave current will appear on the opposite side, even though no electrons cross the dielectric layer.

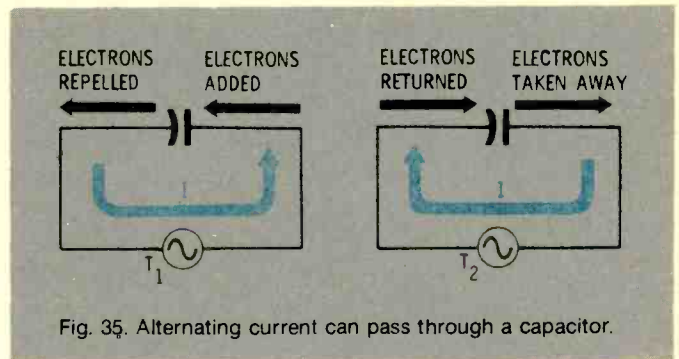

Fig. 35. Alternating current can pass through a capacitor.

PHASE

Just as with inductance, current and voltage are not in phase in a capacitive circuit (Fig. 36). The voltage lags the current (current leads the voltage) by 90° .

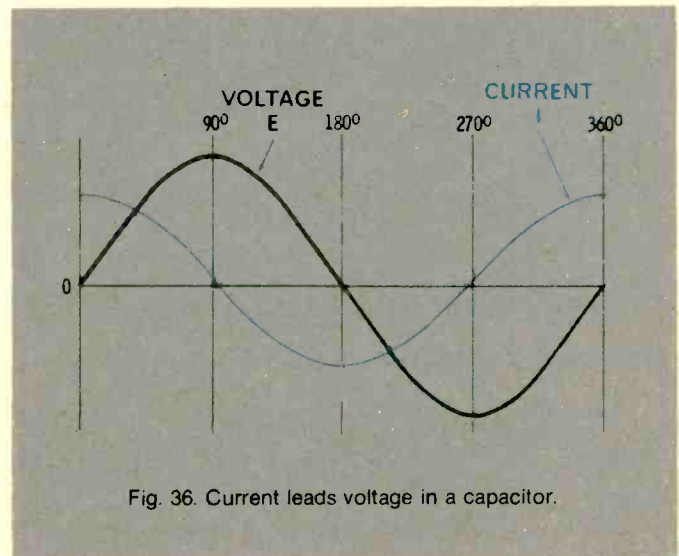

Fig. 36. Current leads voltage in a capacitor.

At any instant, the current flowing into or out of a capacitor is proportional to the rate of change of the applied voltage. This can be seen in the illustration given in Fig. 37. The applied voltage is changing most rapidly at time A, the beginning of the sinewave cycle. Therefore, the current is maximum. At time B, the voltage across the capacitor has reached its peak and for the moment, is not changing. Therefore, current at this instant is zero. At time C, voltage across the capacitor again is changing quite rapidly (but in the negative direction) and, so, the current is at its negative peak. At time D, when the voltage reaches its negative peak and is momentarily not changing, the current waveform passes through zero once more. If we trace the current from point to point along the voltage waveform, the result is a sinewave, but one that **leads the voltage by exactly 90°**. Thus, if the voltage across the capacitor is a continuous sinewave voltage with a constant amplitude, the current through the capacitor circuit has a sinewave waveform that is 90° ahead of the voltage waveform. Refer to Fig. 37.

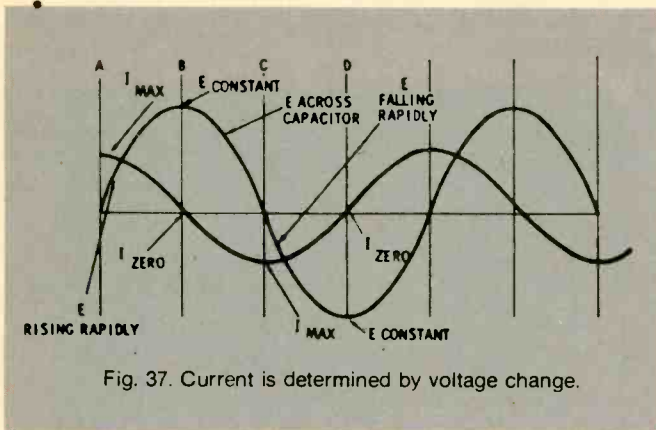

Fig. 37. Current is determined by voltage change.

Thus, current and voltage vectors in a capacitive circuit are 90° out of phase. In the illustration given in Fig. 38, the current vector is **ahead** of the voltage vector by 90°.

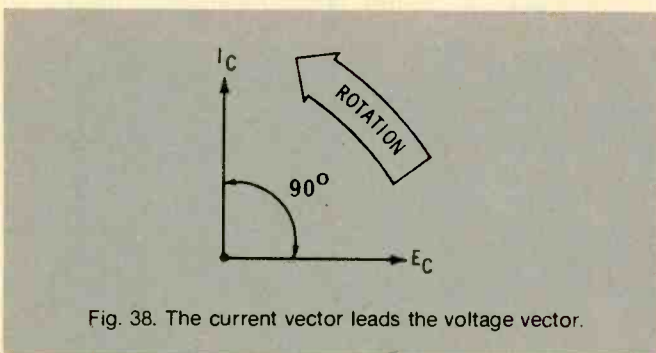

Fig. 38. The current vector leads the voltage vector.

FACTORS AFFECTING CAPACITANCE VALUE

The amount of electrical charge that can be stored in a capacitor (the number of electrons that can be placed on the plate) varies with the **area** of the plates. Consequently, capacitance varies directly with area—if area is doubled, the capacitance is doubled. When the area is doubled or twice as many plates are

connected in parallel, there is twice as much area to store electrons, and the capacitance is therefore twice as great. See Fig. 39.

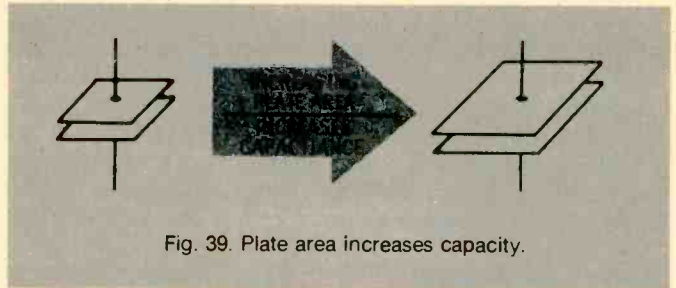

Fig. 39. Plate area increases capacity.

Capacitance can also be increased by placing the plates closer together. When the plates are closer, the attraction between the negative charges on one side and the positive charges on the other side is greater, and thus more charge can be stored. It is, of course, necessary to keep the plates far enough apart so that the charge does not cross the gap. See Fig. 40.

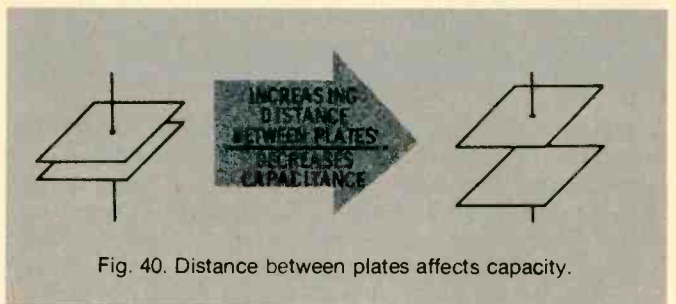

Fig. 40. Distance between plates affects capacity.

Higher values of capacitance can be obtained by using an insulating material (dielectric) other than air. This allows the plates to be placed closer together without permitting the charge to cross the gap. Dielectrics such as mica, glass, oil and Mylar are a few of the materials that can sustain a high electric stress without breaking down. This property is called the **dielectric constant**. See Fig. 41. The higher the dielectric constant is, the better is the dielectric. Air has a dielectric constant of 1, glass about 5, and mica 2.5 to 6.6.

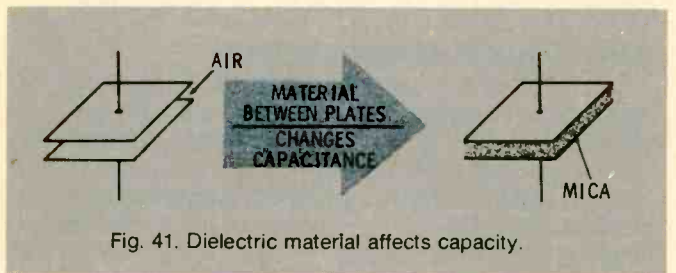

Fig. 41. Dielectric material affects capacity.

CAPACITIVE REACTANCE

Like inductance, capacitance has a reactance—an opposition to the flow of alternating current. But capacitive reactance **decreases** as frequency increases.

Suppose a capacitor is connected in series with an alternating voltage source. There is no resistance in the

circuit. Because the circuit in Fig. 42 contains no resistance, the voltage across the capacitor will be the same value as the source voltage at every instant.

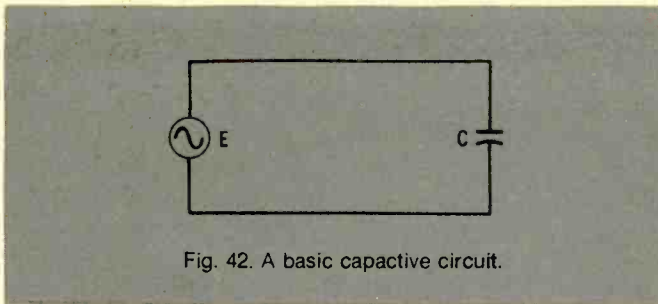

Fig. 42. A basic capacitive circuit.

When a capacitor is charged up to voltage E , it stores an amount of energy equal to the capacitance times the voltage. If the peak voltage of the AC source is E , the capacitor will have stored a particular amount of energy every time the voltage sinewave hits its peak, and again stores that amount whenever the voltage reaches its negative peak. Refer to Fig. 43. The energy depends only on capacitance and peak voltage.

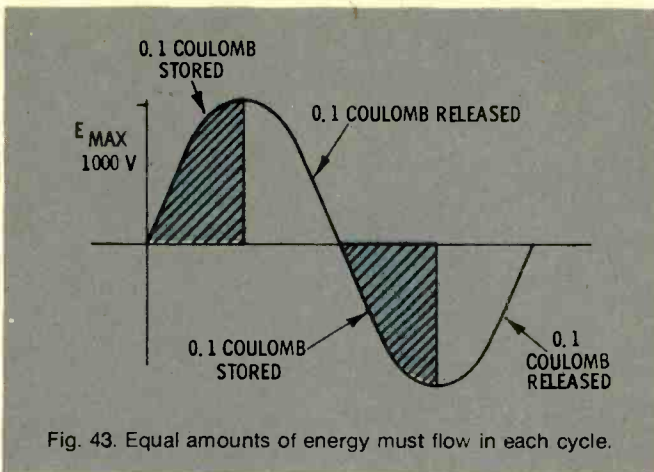

Fig. 43. Equal amounts of energy must flow in each cycle.

What happens when the frequency of the power source is doubled? If the peak voltage (E) is unchanged, the capacitor will charge every half cycle to the same amount as before. But, it will have to do this twice as fast because the frequency is doubled. This means that the same amount of energy must flow into the capacitor in only half the time. See Fig. 44. And, since the voltage is the same, we must have twice the current to supply this same amount of total energy.

What does this mean? The frequency was doubled, and this doubled the current flowing into the capacitor—yet, the input voltage remained the same. A pure capacitance lets twice as much current flow if the frequency is doubled.

Capacitive reactance is the opposition that pure capacitance offers to the flow of current. It is expressed in **Ohms**, and its symbol is X_C . Capacitive reactance depends on frequency. As the frequency increases, the rate of change of applied voltage increases, and the current also increases. As the frequency is reduced, the rate of change of the voltage goes down, and less current will flow.

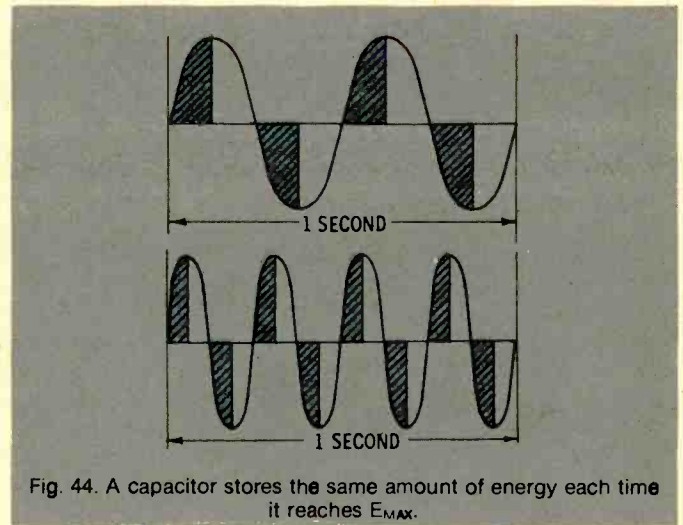

Fig. 44. A capacitor stores the same amount of energy each time it reaches E_{MAX} .

At this point, you can more easily see why capacitor current leads the voltage across the capacitor. It is necessary for the capacitor to charge up to the given voltage, and this charging is done by the current. Hence, the charging current will reach its maximum value at the time the charging is going on at the greatest rate; that is, when the rate of change of voltage is the most rapid.

As the capacitor approaches full charge, the voltage rate of change slows down, and the current decreases. When the capacitor is fully charged and its voltage has reached maximum, there is no charging current flowing—that current has already dropped to zero at this time. A similar process occurs during discharging. At all times, current leads the voltage by 90° , or one quarter of the cycle. In a steady-state AC situation, when the applied voltage has a sinewave waveform, both voltage and current will have sinewave waveforms.

Capacitive reactance depends on frequency. Since it lets more current flow as the frequency increases, capacitive reactance must decrease as the frequency increases. It also depends on the size of the capacitance. As capacitance increases, more current must flow into the capacitor to charge it to the same voltage (since the amount of energy stored equals $C \times E$). As a result, capacitive reactance decreases when capacitance increases. The formula for capacitive reactance is:

$$X_C = \frac{1}{2\pi f C} \text{ ohms}$$

where,

f is the frequency in Hertz,

C is the capacitance in Farads.

Capacitive reactance can be used in calculating current in a purely capacitive circuit with the use of Ohm's law.

$$I = \frac{E}{X_C}$$

A BASIC CAPACITIVE CIRCUIT

First, let's review what you have learned about

capacitance by applying it to the basic capacitive circuit shown in Fig. 45. You have already learned that when a sinewave AC voltage is applied, the current in a capacitor always leads the voltage by 90° . You have also learned that a capacitor consumes no power; all the energy it takes out of a circuit in one quarter cycle is returned in the next quarter cycle.

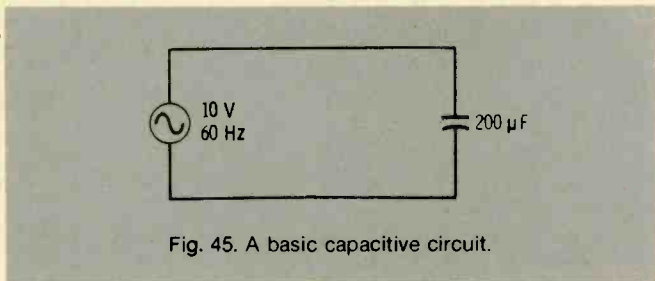

Fig. 45. A basic capacitive circuit.

Both of the above statements are true, not only for a single capacitor, but also for any combination of capacitors. In fact, any circuit that contains only pure capacitances, no matter how many capacitances it may have, it will behave as if it were one capacitor.

CAPACITORS IN PARALLEL

Capacitors add in parallel. See Fig. 46. It is easy to understand why this is true if you remember that the more plates a capacitor has, the greater is its capacitance. If two capacitors are connected in parallel, you can find their equivalent capacitance just by adding their values. If a $200\text{-}\mu\text{F}$ and a $400\text{-}\mu\text{F}$ capacitor are connected in parallel (see Fig. 47), the equivalent capacitance of the combination is $200\text{ }\mu\text{F}$ plus $400\text{ }\mu\text{F}$, or $600\text{ }\mu\text{F}$. This is also true with three, four, or any other number of capacitances connected in parallel.

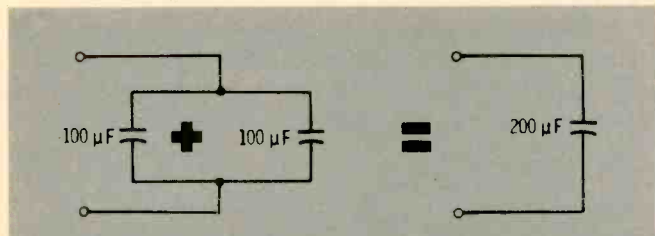

Fig. 46. The more plates a capacitor has, the greater is its capacity.

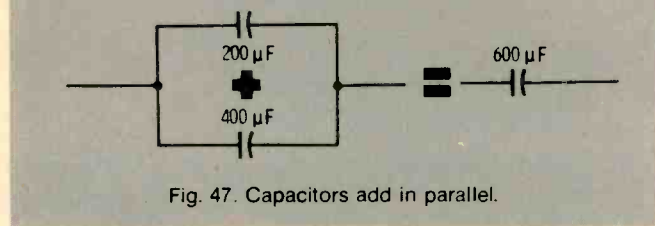

Fig. 47. Capacitors add in parallel.

CAPACITORS IN SERIES

If two capacitors are connected in series (see Fig. 48), what is their equivalent capacitance? We cannot simply add C_1 and C_2 together. Instead, we use the relationship:

$$C_{eq} = \frac{C_1 \times C_2}{C_1 + C_2}$$

What is the total capacitance of $200\text{ }\mu\text{F}$ and $400\text{ }\mu\text{F}$ connected in series? Using the above relationship, the total capacitance is calculated to be:

$$C_{eq} = \frac{200 \times 400}{200 + 400} = 133\text{ }\mu\text{F}$$

Notice that this equivalent value is smaller than either of the individual capacitor values.

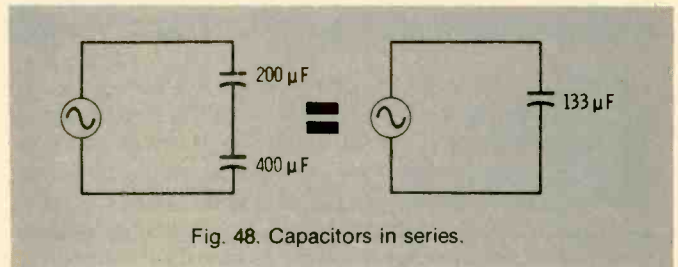

Fig. 48. Capacitors in series.

Complicated circuits can be simplified by analyzing them in steps as shown in Fig. 49.

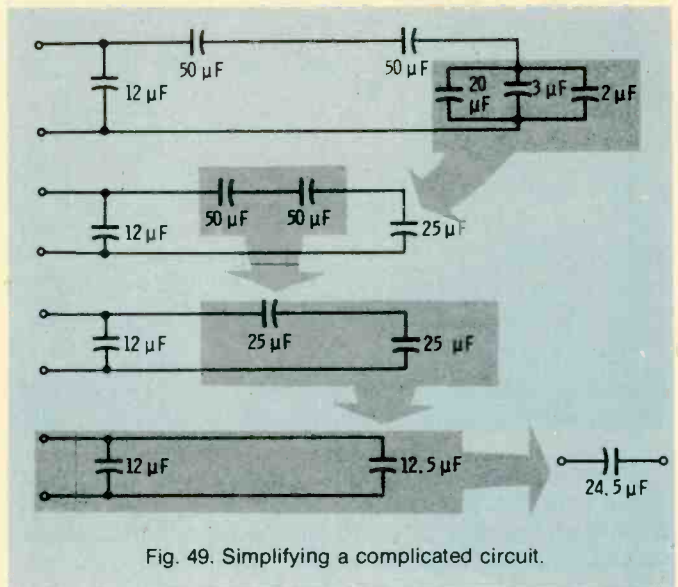

Fig. 49. Simplifying a complicated circuit.

On the preceding pages, capacitance values were combined, not capacitive-reactance values. You must not confuse the two. To combine capacitive-reactance values, whether in series or in parallel, use the same rules that apply to resistance—add series values and combine parallel values by use of the formula:

$$X_{eq} = \frac{X_1 \times X_2}{X_1 + X_2}$$

RC CIRCUITS

Actually, an entirely pure capacitance does not exist. The leads of capacitors have some small value of resistance. Also, the dielectric layer is never quite perfect; it has some extremely high value of resistance. So, if you wanted to be very accurate, you would

represent these unwanted resistances by inserting their values in your circuit diagram, and treat them just as if they were actual resistors. For the most practical purposes, however, you can disregard them.

Now let's see what happens if we put capacitors and resistors in the same circuit. As you already know, we cannot add resistance and capacitance, because they are two different quantities (resistance is measured in Ohms, capacitance in Farads). Instead, it is necessary to use capacitive reactance, which you learned about in the previous chapter. However, just as with inductance, in order to add resistance to capacitive reactance, it must be remembered that a resistive current is in phase with the voltage, while a capacitive current leads the voltage by 90° . So the two cannot be added directly—they must be added vectorially (Fig. 50).

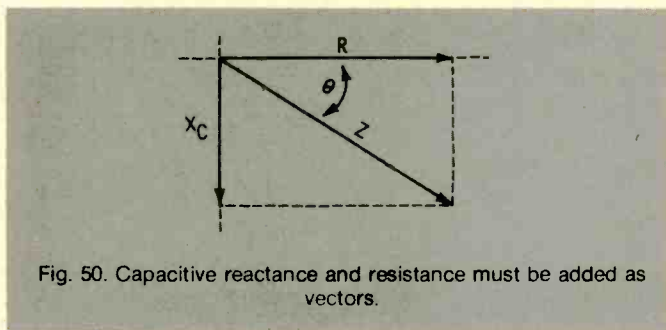

Fig. 50. Capacitive reactance and resistance must be added as vectors.

IMPEDANCE

The capacitive-reactance vector is 90° behind the resistance vector in Fig. 50. The resulting quantity, **impedance**, is somewhere between the two, and its length (quantity) is the diagonal of the rectangle they form. This is **capacitive impedance**, which is different from inductive impedance because it lags the resistance vector. The way to write capacitive impedance is $R - jX_c$; the minus sign tells the story. All inductive impedances are represented by a $+j$ and all capacitive impedances by a $-j$ in front of the X .

If you have a table of trigonometric functions, you can get a more accurate measurement of impedance, using the same formulas that you used to find inductive impedance. Remember, these formulas apply to both inductive and capacitive impedance.

$$R = Z \cos \theta \quad X_c = R \tan \theta \quad X_c = Z \sin \theta$$

$$R = \frac{X_c}{\tan \theta} \quad \frac{X_c}{R} = \tan \theta \quad Z = \frac{R}{\cos \theta}$$

$$\frac{R}{Z} = \cos \theta \quad \frac{X_c}{Z} = \sin \theta \quad Z = \frac{X_c}{\sin \theta}$$

RC TIME CONSTANT

The ratio between R and C has an important effect on the characteristics of a circuit. The way this ratio affects AC voltage and currents is indicated by a **time constant** in much the same way that the effects of combined inductance and resistance were indicated.

What happens if you apply a pulse, such as a square wave, to a series RC circuit? See Fig. 51. The capacitor will oppose the sudden change of voltage and will gradually **charge** to source voltage E . The rate of charge (the initial current that will flow) is limited by resistance R . In fact, the initial current will be $I = E/R$

and will gradually decrease to zero as the voltage **builds up** across the capacitor.

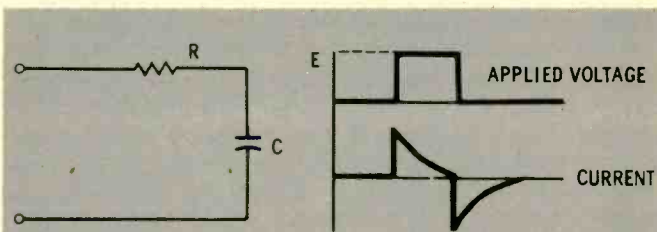

Fig. 51. A square pulse through an RC circuit.

The voltage across the capacitor will start at zero and will build up smoothly until it equals source voltage E . The voltage across the resistor will, at any instant, equal the difference between the source voltage and the voltage across the capacitor; it will also be a spike as shown (Fig. 52).

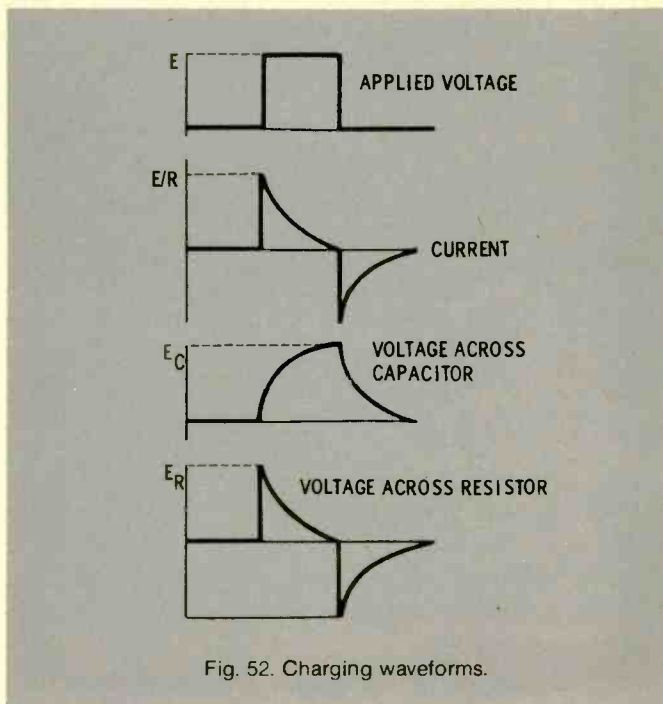

Fig. 52. Charging waveforms.

The rate of charging—the steepness of the capacitor voltage curve—depends on how much current the resistor will allow to flow. The higher the resistance, the less the current flow and the slower will be the charging rate. This fact is expressed in numbers by the **time constant** of the circuit. The time constant of a series RC circuit is simply $R \times C$, where R is Ohms, C is in Farads, and the time constant is in seconds. **RC** is the time it takes the capacitor to charge to 63.2% of the source voltage. For example, if R is 10,000 Ohms and C is 10 microFarads, RC is $10,000 \times \frac{10}{1,000,000} = 0.1$ second.

When a capacitor has been charged, it actually contains a certain amount of stored energy. The stored energy is C times E coulombs, where C is the

capacitance in Farads and E is the voltage to which the capacitor is charged.

If a charged capacitor is connected in a circuit, its stored energy is released into the circuit. An example of this is a battery-capacitor photographic-flash circuit. Capacitor C is charged up to the battery voltage by throwing the switch to position **A** (Fig. 53A). The rate of charge depends on the resistance in the battery circuit (wire resistance and the internal resistance of the battery). When a flash is desired, the switch is moved over to position **B** (Fig. 53B). The capacitor,

However, if the amount of energy stored is important, the delay can only be varied by changing the resistance.

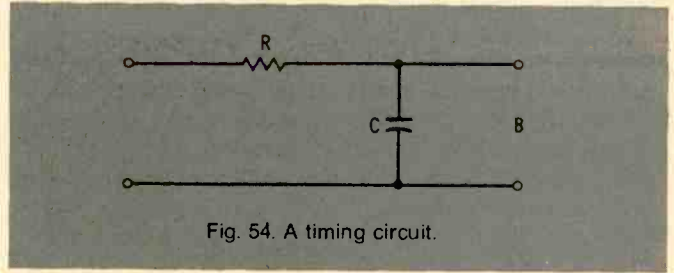

Fig. 54. A timing circuit.

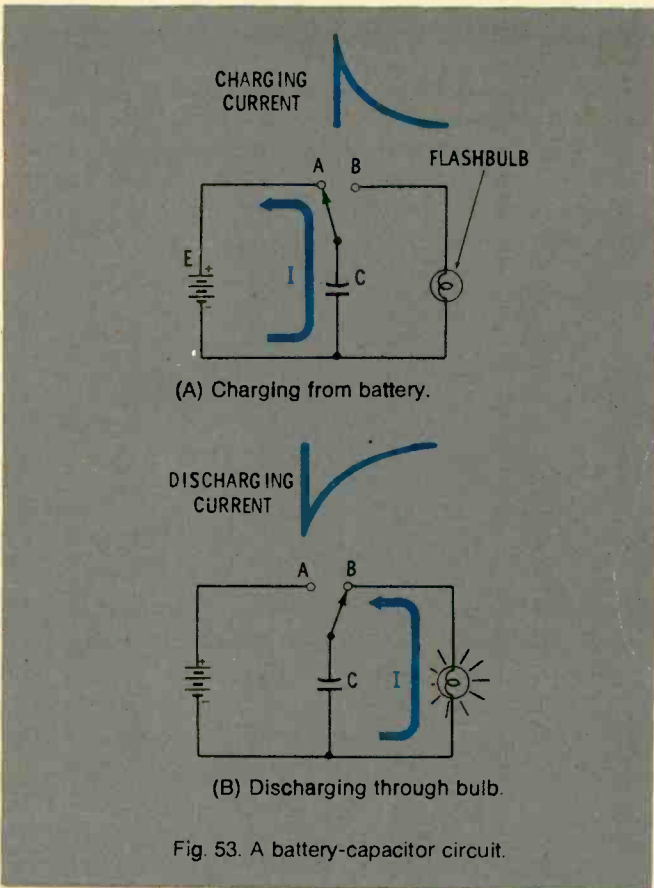

Fig. 53. A battery-capacitor circuit.

which is charged to full battery voltage (E), has not opposing voltage in the new circuit, and its discharge is limited only by the resistance of the flash bulb. The stored energy flows through the flash bulb and, in doing so, fires the bulb. The discharging current follows the curve shown in the figure; again, the speed of discharge depends on the time constant of the circuit.

An RC series circuit can be used as a timing device. See Fig. 54. It is, in fact, often used this way (e.g., in television receivers). In the circuit of Fig. 54, the length of time that it will take for the capacitor voltage to rise to some given value can be calculated. If some device (which will be triggered only when this given value of voltage is reached) is connected across the output terminals **B**, the device (such as a gas diode) will be triggered after a predictable time delay from the time that the input voltage (E) is applied.

The length of the time delay can be controlled by varying either the resistance or the capacitance.

RLC IMPEDANCE

When vector diagrams are used to find the impedance and phase angle (as in the previous chapters), $+jX_L$ is always drawn upward, while $-jX_C$ is always drawn downward. This leads to the idea that inductance and capacitance provide opposite reactions.

What happens if a circuit contains both inductance and capacitance in series? The two reactances cannot be just arithmetically added to find the total reactance. $+jX_L$ and $-jX_C$ tend to offset each other, and the total effect is their difference.

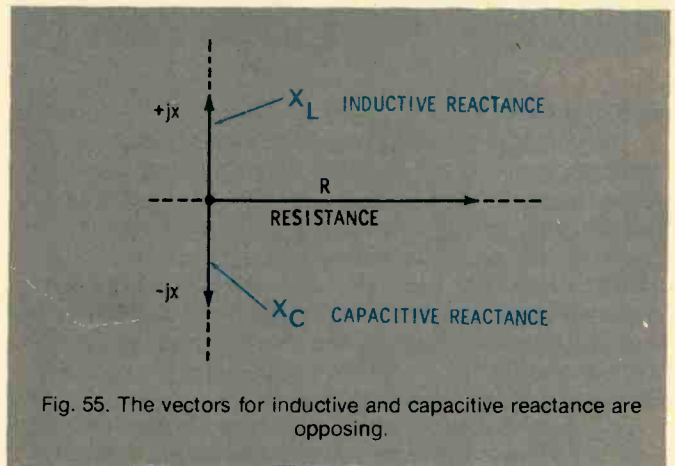

Fig. 55. The vectors for inductive and capacitive reactance are opposing.

This difference is in the direction of the greater of the two reactances (Fig. 55). So, if a circuit contains a capacitor, the reactance of which is $-j50$ Ohms, and an inductor, the reactance of which is $+j100$ Ohms, the net result is equivalent to an inductive reactance of $+j50$ Ohms. A series circuit containing L and C behaves either as a capacitor or as an inductor, depending on whichever of the two components has the greater reactance at the operating frequency.

If a resistor is connected in series with an LC circuit, the impedance of the circuit will simply be the resultant reactance (whether inductive or capacitive) in series with the resistor.

RESONANCE

A special case arises when the capacitive reactance and the inductive reactance are equal. When this condition exists, the reactances cancel each other and the circuit appears to be purely resistive. This can

happen at only one frequency, however, for each particular set of inductive and capacitive values. At a low frequency, the inductive reactance is low and the capacitive reactance is high. The circuit, therefore, behaves as a capacitance. If the frequency of the applied voltage is gradually increased, the inductive reactance will gradually decrease. At some point, the two reactances become equal, and thus cancel. This point is called the **resonant frequency** of the circuit. If the frequency is increased further, the inductive reactance becomes greater than the capacitive reactance, and the circuit will behave as an inductor.

Every L and C combination has one, and only one, resonant frequency. It is the frequency at which the inductive and capacitive reactances are equal (Fig. 56).

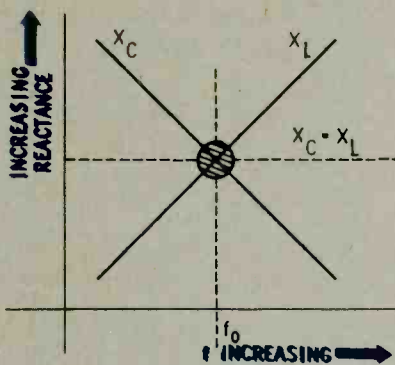

Fig. 56. Every LC combination has one resonant frequency.

RESONANT FREQUENCY CALCULATION

The resonant frequency (f_0) formula is derived as follows:

$$2\pi f_0 L = \frac{1}{2\pi f_0 C}$$

Multiplying by f_0 ,

$$2\pi f_0^2 L = \frac{1}{2\pi C}$$

Dividing by $2\pi L$,

$$f_0^2 = \frac{1}{4\pi^2 LC}$$

Taking the square root of both sides,

$$f_0 = \frac{1}{2\pi\sqrt{LC}}$$

Q OF A RESONANT CIRCUIT

At resonance, the voltage across the capacitor and across the inductor is greater than at any other frequency. See Fig. 57. The effective current in the circuit is also higher at the resonant frequency than it is below or above resonance.

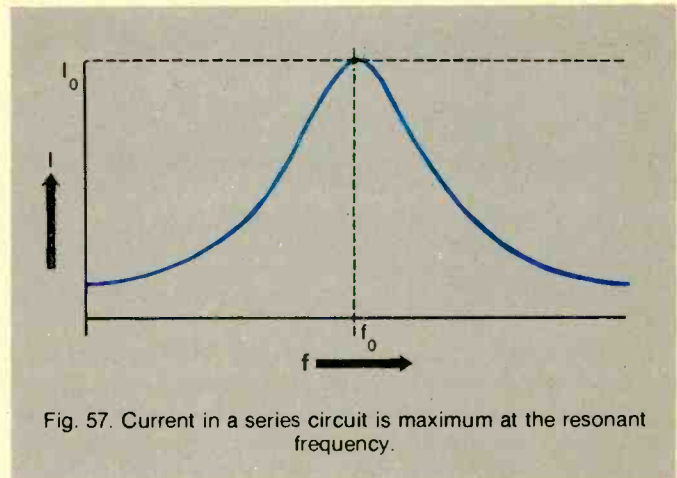

Fig. 57. Current in a series circuit is maximum at the resonant frequency.

The quality of a resonant circuit can be measured by the **Q factor**. The Q of a circuit is the ratio of the energy stored in the capacitor and inductor divided by the energy dissipated in the resistor.

The amount of reactive opposition to current flow at a specific given frequency is not affected by the Q of the circuit. The resistive opposition, however, does vary according to the Q factor. This means that the shape of the resonance curve depends on this factor. If the frequency is changed from f_0 to a frequency where the reactance is low, and if the Q is high (resistance is only a few Ohms), the total impedance will be halved. If the Q is low (resistance is high), the total impedance will be increased by only a small amount, and the current decrease will be very small. The Q factor determines the exact shape of the resonance curve of a circuit. For example, if the resonant frequency is multiplied by $1/Q$, and if the frequency of the input signal is changed from the resonant frequency by this amount, the current will be 0.707 times the resonant current. However, if the frequency is changed by $1/2Q$ times the resonant frequency, the current will be 0.447 times the resonant current. Refer to Fig. 58.

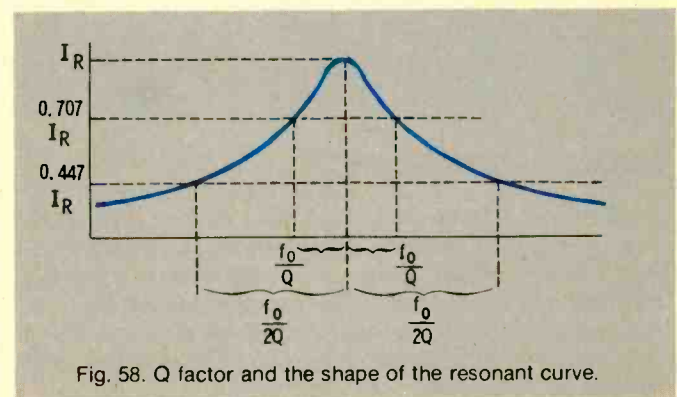

Fig. 58. Q factor and the shape of the resonant curve.

APPLICATIONS

Frequency-selective properties of series resonant circuits are useful in applications where it is desired to pass one particular frequency with more ease than others. Thus, the circuit can act as a filter. Refer to Fig. 59.

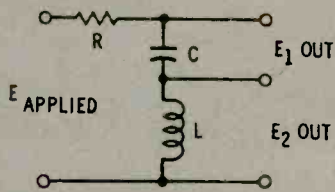

Fig. 59. A bandpass filter.

If the voltage across either L or C is used for the output, the voltage will be much greater for signals having the resonant frequency than for signals above or below this frequency. Such a circuit is called a **bandpass filter**. The width of the bandpass depends on the circuit Q—the higher the Q, the sharper the resonance curve and the narrower the bandpass.

In a radio-frequency circuit, a high-Q tuned circuit can be used to select the desired station and reject all others. In a power supply, a circuit using fairly large L and C values may be used to reject undesired frequencies.

PARALLEL RESONANT CIRCUITS

A parallel resonant circuit is made up of inductance and capacitance (see Fig. 60) so that each of the two branches shows reactance. The capacitive losses are usually associated with the coil rather than with the capacitor. The resistance is usually shown as being in series with the inductance.

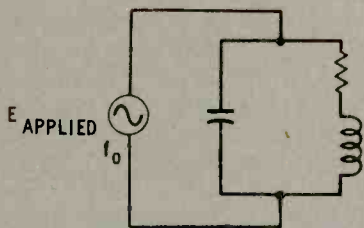

Fig. 60. A parallel resonant circuit.

PARALLEL RLC CIRCUITS

When an AC voltage is applied to a parallel RLC circuit, each of the two branches shows reactance. The capacitive reactance in the capacitor branch is high at low frequencies, and decreases as the frequency increases. Similarly, the inductive reactance of the inductor branch is low at low frequencies, and increases as the frequency increases.

The capacitor has a high reactance and the inductor a low reactance at frequencies below resonance. Consequently, most of the current flows through the inductive branch and lags the applied voltage. Similarly, if the frequency is above resonance, most of the current will flow in the capacitive branch and will lead the applied voltage.

At some particular frequency, the two reactances in

a parallel resonant circuit are exactly equal. Since there is an AC voltage applied across each branch, both kinds of current are present—an inductive current in the inductive branch and a capacitive current in the capacitive branch. At resonance, the two currents are equal. But because one of the current **leads** the applied voltage by 90° and the other **lags** the voltage by 90° , the two currents are 180° out of phase with each other. This means that they cancel (add up to zero). See Fig. 61.

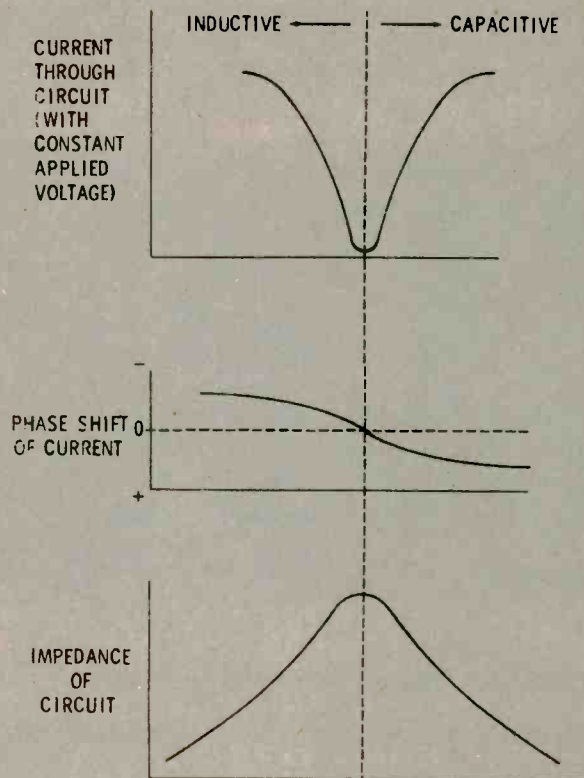

Fig. 61. I_L , I_C , and impedance in a parallel resonant circuit.

The applied voltage was kept constant as the frequency was varied. Since current is minimum through the circuit at resonance, a parallel circuit has a higher impedance at the resonant frequency than at any other.

TIME CONSTANTS

L/R and RC time constants (see Figs. 62 and 63) indicate how quickly current or voltage builds up when a sudden increase in DC voltage (such as a square wave) is applied to a particular combination of L and R or C and R. One time constant is the time required for voltage (or current, depending on the circuit) to reach 63% of its peak value. The percentage of the peak value can be calculated for any elapsed time if the time constant of the circuit is known. The curves for the voltage increase across a capacitor, or the current increase through an inductor, are exactly the same if the time constants of the two circuits are the same.

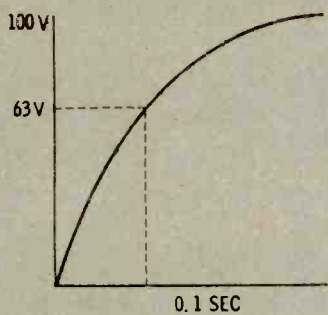

Fig. 62. Capacitor voltage when RC equals 0.1 second.

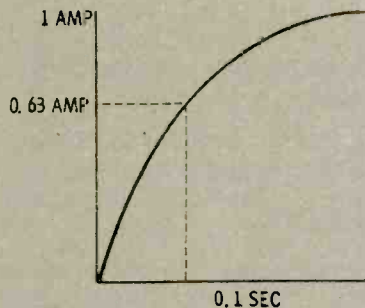

Fig. 63. Inductor current when L/R equals 0.1 second.

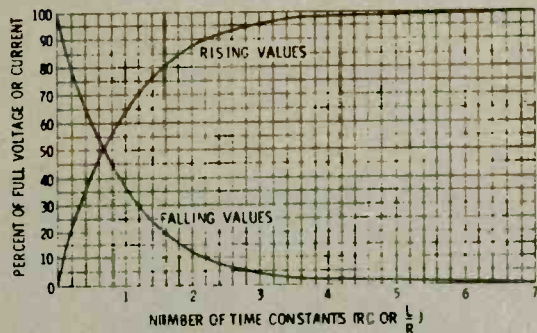

Fig. 64. Universal time-constant chart.

A **universal time-constant chart** can be used to calculate the growth and decay of voltage and currents in any RL or RC circuit to which a sudden step voltage is applied. All you have to know is the final voltage and current, and the time constant of the circuit. See Fig. 64.

Calculate both the voltage across the capacitor and the current in the circuit in the diagram shown in Fig. 65. The time constant is:

$$RC = 1000 \times 0.5 \times 10^{-6} = 0.5 \times 10^{-3} = 0.5 \text{ millisecond}$$

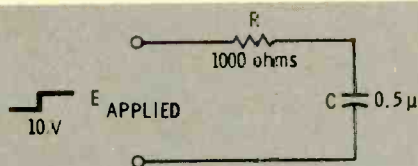

Fig. 65. Circuit for an example problem.

When the 10 Volts is first applied, the current will be $E/R = \frac{10}{1000} = 0.01$ Ampere. Using the time constant and the falling curve in the chart, it can be seen that at the end of one time constant (0.5 millisecond), the current is about 37% of its full value ($0.37 \times 0.01 = 0.0037$ ampere). At the end of two time constants (1 millisecond), current will be 13% ($0.13 \times 0.01 = 1.3$ milli-Amperes). At the end of three time constants, the current will be 5% of its full value ($0.05 \times 0.01 = 0.5$ milliAmpere), and so on.

The voltage across the capacitor can be determined in a similar manner. When the switch is first closed, E_c is zero. This voltage gradually increases to the value of the power supply, or 10 Volts. At the end of one time constant (0.5 millisecond), E_c will be 63% of maximum (6.3 Volts). At the end of two time constants (1 millisecond), E_c will be 87% of maximum (8.7 volts), etc.

The same chart can be used when the voltage is suddenly removed (the switch is opened). In this case, E_c decays according to the falling curve.

QUESTIONS ANSWERS

Here are 29 questions and answers on the subject material you have just completed reading. The questions are taken from the original published work, Basic Electricity/Electronics that is described on the first page of this basic course. The questions and answers are only a small portion of the many that interlace the original work where they follow immediately after the subject matter presented. Should you have trouble answering the questions presented here, the Editors suggest that you obtain the original volume, or volumes, and begin a self-teaching program to bolster your basic understanding of AC circuits.

- Q1. Voltage and current are always in phase in AC circuits containing only _____.
- Q2. An electric heater, an electric iron, and a lamp are fed from the same outlet (connected in parallel). Find the equivalent resistance if you know that the individual resistances are 4 Ohms, 30 Ohms, and 150 Ohms, respectively.
- Q3. When current is trying to increase, inductance (makes it increase more quickly; slows down the increase).
- Q4. What units are used to measure the inductance of a coil?
- Q5. An inductor stores electrical energy by producing a _____.
- Q6. Moving a conductor in a magnetic field _____ a current in the conductor.
- Q7. How is the inductive reactance of a circuit affected by the input signal?
- Q8. If an Ohmmeter is used to measure a coil, it will indicate (DC resistance, inductive reactance).
- Q9. A filter that allows only high frequencies to pass

is called a _____.

- Q10. How does a transformer work?
- Q11. A "pure" inductance (which has no resistance) would have a (high, low) Q.
- Q12. The time constant of a circuit indicates the time it takes a pulse to reach ___% of its maximum value in that circuit.
- Q13. Name two differences between capacitance and inductance.
- Q14. Explain what happens when you remove the battery from across a charged capacitor and place a shorting wire across the leads of the capacitor.
- Q15. What would happen if you tried to repeat the above experiment without first discharging the capacitor?
- Q16. When AC voltage across a capacitor is maximum, the AC current through the circuit is _____.
- Q17. When an AC current through a capacitor circuit is maximum, the AC voltage across the capacitor is _____.
- Q18. If you had two capacitors of low value, how could you combine them to get a larger capacitance?
- Q19. How does a mica capacitor differ from an air capacitor of the same physical size?

- Q20. How does an increase in the input frequency affect capacitive reactance? Inductive reactance?
- Q21. Capacitive impedance is expressed in component form as $R - jX$. Inductive impedance is expressed as _____.
- Q22. How do capacitance and inductance affect a DC input?
- Q23. What is the resonant frequency of a circuit containing 2 Henrys in series with $2 \mu F$?
- Q24. At what frequency would you measure the Q of a circuit?
- Q25. What is the Q of a circuit whose resonant frequency is 1000Hz, inductance is 0.5 Henry, and resistance is 10 Ohms?
- Q26. What is the impedance at resonance of a parallel resonant circuit consisting of a 1-Henry inductor with 1 Ohm of DC resistance, and a $1-\mu F$ capacitor?
- Q27. If the resonant frequency of a circuit is 1000 Hz, L is 1 Henry, and the Q of the circuit is 80, what is the impedance of the circuit at resonance?
- Q28. Is a high or a low power factor desirable in the electrical circuits that are used to transmit the power?
- Q29. How can inductive reactance be cancelled in order to increase the power factor in an inductive circuit?

- A10. An AC current produces a changing magnetic field in the primary coil of a transformer. This changing field produces an AC current in the secondary coil of the transformer.
- A11. A "pure" inductance would have a high Q.
- A12. The time constant of a circuit indicates the time it takes a pulse to reach 63% of its maximum value in that circuit.
- A13. Capacitance opposes a change in voltage while inductance opposes a change in current. Capacitance blocks direct current while an inductance does not.
- A14. The electrons from the negative plate rush through the shorting wire to the positive plate until both plates have the same number of electrons. The voltage across the plates is then at zero potential.
- A15. Once the capacitor has been charged, there is no "kick" (needle movement) when you connect the ohmmeter probes. The capacitor is already full and can take no more charge.

- A1. Voltage and current are always in phase in AC circuits containing only resistance.
- A2. $R = 3.44 \text{ Ohms}$
- A3. When current is trying to increase, inductance slows down the increase.
- A4. Henrys, millihenrys, and microhenrys are units used to measure inductance.
- A5. An inductor stores electrical energy by producing a magnetic field.
- A6. Moving a conductor in a magnetic field induces a current in the conductor.
- A7. Inductive reactance increases as the frequency of the input signal increases.
- A8. If an Ohmmeter is used to measure a coil, the reading will indicate DC resistance.
- A9. A filter that allows only high frequencies to pass is called a high-pass filter.

- A29. Inductive reactance can be canceled by capacitive reactance.
- A28. A high power factor is desirable.
- 502,400 Ohms
- A27. $Z_o = 2\pi fLQ = 6.28 \times 1000 \times 1 \times 80 =$
- A26. $Z_o = \frac{L}{CR} = \frac{0.00001 \times 1}{1} = 1 \text{ Megohm}$
- A25. $Q = \frac{R}{X_L} = \frac{R}{2\pi fL} = \frac{10}{3140} = 314$
- A24. At its resonant frequency.
- A23. $f_o = \frac{1}{6.28 \times \sqrt{2 \times 0.000002}} = 79.6 \text{ Hz}$
- A22. Capacitance blocks DC current. Inductance offers no opposition to DC current.
- A17. When AC current through a capacitor circuit is maximum, AC voltage across the capacitor is zero.
- A18. Combining two capacitors in parallel would produce the same effect as a single capacitor with more plates and, therefore, would result in a higher capacitance.
- A19. A mica capacitor has a higher capacitance than an air capacitor of the same physical size.
- A20. An increase in frequency results in a decreased inductive reactance, and an increased inductive reactance.
- A21. Inductive impedance is expressed as $R + jX$
- A16. When an AC voltage across a capacitor is maximum, AC current through the circuit is zero.
- A17. When AC current through a capacitor circuit is maximum, AC voltage across the capacitor is zero.

THE WAY AVC WORKS

□ A WORLD WITHOUT AVC—Automatic Volume Control—would be filled with fractured audio and video. Explanation is that AVC is the steadying force in receivers of most every description—from tiny AM portables to communications receivers, TV sets, and just about everything else that breathes in a signal. Remove AVC from your table radio and it would probably break up on local stations. Take it out of your TV set and color might scramble and spill through the image—or pictures turn negative because of signal overload.

Blast It. It's been said that AVC "makes strong signals weak and weak signals strong." That simple definition goes back to AVC's original objective of reducing "speaker blasting." The phrase is perfectly descriptive because an uncontrolled receiver produces ex-

cessively loud sounds in the speaker while receiving strong signals. You *could* adjust the radio's volume control by hand, but imagine doing it—in an automobile while driving. Your hand might never leave the volume control!

This is where AVC comes to the rescue. It senses the wavering signal, develops a control voltage in proportion to that signal, then applies it as a continuous correction. It also cures a problem that no amount of volume-control fiddling can cure. It's an overload condition where strong signals drive the receiver's early stages into highly distorted operation, resulting in mushy, unintelligible audio in the speaker.

Though a car in motion is one cause of fluctuating signals, there are others. Atmospheric fading due to changes in the ionosphere has a tremendous effect

on the strength of shortwave (3 to 30 MHz) stations. At higher frequencies (VHF and UHF-TV, for example), passing vehicles, changes in tree foliage, and even moisture content in the air vary the number of microvolts induced in an antenna by a distant transmitter.

In all of these cases, an AVC circuit attempts to compress or expand the signal into some mid-range or average value. As you might suspect, AVC can't recover a signal deeply submerged in atmospheric noise and make it readable. Nor can it clean the snow from a far-away TV station arriving in a remote fringe area. But it is capable of some pretty miraculous stunts, as we'll see shortly.

The AVC Idea. Almost every AVC circuit follows a similar general route. First, it taps into the receiver circuit at

some point to sample a bit of the incoming signal. The sample provides information on the relative strength of the arriving station. Next, the sampled signal is processed into a form which enables it to control the radio-frequency amplification of the receiver. This becomes the AVC control voltage and it's fed back to some earlier point in the receiver.

If a powerful station is being received, it produces a high AVC voltage, which reduces the receiver's ability to amplify. Upon receipt of a weak signal, little AVC voltage develops, so the receiver runs at high amplification.

From Carrier to Control. The overall idea appears in Fig. 1. We've shown a standard broadcast station transmitting a signal whose carrier is increasing from weak to strong in three steps. Note that the carrier is assumed to be originating from the station at three fixed levels, with no audio modulation at this time. (Audio causes a complication we'll get to in a moment.)

The changing carrier signal enters the receiver antenna and proceeds through RF and IF stages until it reaches the diode detector. Since the alternating carrier can go through the diode in one direction only, it's rectified so only the negative portion appears at the resistor forming the diode load. The AVC signal, however, is still hidden within the rectified carrier, as shown by the dotted line. This means that it must be processed further before it becomes a suitable control signal—a DC voltage which varies in step with carrier strength.

This is where the problem of audio modulation (voice or music on the carrier) complicates AVC development. The trouble is that intelligence on the carrier is AM, or amplitude modulation, which is electrically similar to the changing carrier strength AVC will attempt to fight. It would hardly be suitable if AVC attacked loudness changes

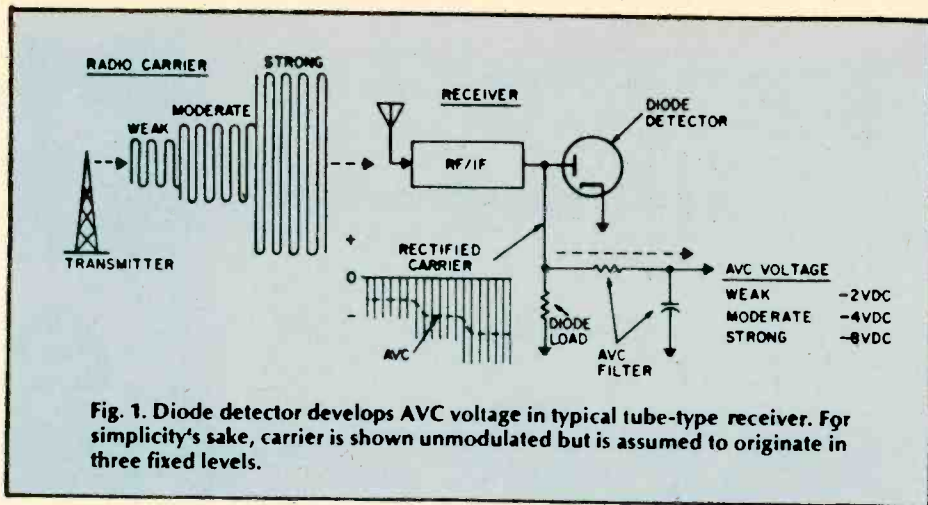

in the program, rather than average changes in carrier signal. Fortunately, it's possible to fashion a filter which ignores audio in the sampled carrier.

As shown in Fig. 1, there's an AVC filter comprised of a resistor and capacitor. In a typical tube circuit these values are a few megohms for the resistor and about .05 μ F for the capacitor. They form a filter which responds at the rate of about 0.1 second (its *time constant*). This interval of time has been carefully selected to fulfill certain boundaries of AVC operation.

First, the filter must remove any audio modulation from the sampled portion of carrier. Since audio variations occur much faster than 0.1 second (the lowest audio tone is about 20 times per second), the filter smooths out any audio in the AVC circuit. Yet, the AVC filter must not respond *too* slowly. When driving in a car, for example, you might receive a fluttering signal and need fast-acting AVC to exercise quick control.

The 0.1-second filter, therefore, is designed as a compromise which attempts to fit AVC response between the two extremes. In some advanced receivers, an AVC selector switch (Fig. 2) enables the operator to choose his

rate to improve the receiver's performance on certain specialized signals such as code (CW), single sideband, or other non-standard carriers.

DC Up Front. To this point the circuit has developed a control voltage that's synchronized to incoming carrier strength. As shown in Fig. 1, the carrier has produced a shift of from -2 to -8 DC volts at the output of the filter. This is approximately the AVC voltage you'd measure in typical tube-type receivers. Now it's only necessary to provide a feedback loop to carry the AVC back to an earlier stage. How this is done is illustrated in the actual schematic of a typical tube radio in Fig. 3.

The AVC signal is developed across the diode load resistor and filtered in the resistor and capacitor indicated (R2 and C6). From there, the line is usually termed the *AVC bus* and extends back to the control grid of the IF amplifier. As an incoming signal grows stronger, a correspondingly higher negative AVC voltage is created. Result is that the gain of the IF stage is reduced accordingly.

Solid AVC. Millions of tube receivers still survive, but solid-state should end that era in a few years. Transistor receivers are subject to the same signal

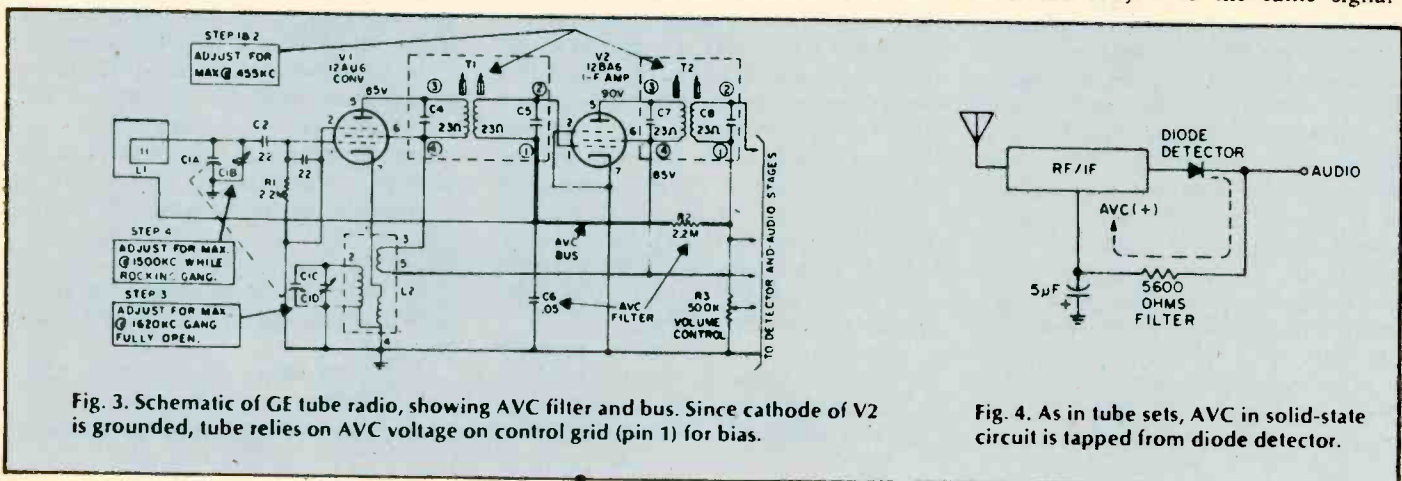

Fig. 4. As in tube sets, AVC in solid-state circuit is tapped from diode detector.

fluctuations and similarly require AVC circuitry. In looking at transistor circuits, you may find that the term *voltage* is often supplanted by *current*.

When discussing amplification in tubes, it's almost always a matter of controlling grid voltage, which is generally negative in polarity. (The current flow in a receiving tube grid is infinitesimal and usually ignored.) Transistors, though, may be discussed in terms of current since the terminal voltages (unlike tubes) are very low. Because of these differences, AVC action in tube circuits is usually described as *negative grid voltage*, while the solid-state version is in terms of *base current*.

Another difference is that the polarity of a receiving tube grid is almost always negative; transistor current, in contrast, may flow in either direction, depending on whether an npn or a pnp transistor is being controlled.

Schematics for solid-state AVCs are fairly close in appearance to tube versions, as shown in the typical portable in Figs. 4 and 5. Note that a sampling of carrier signal is taken at the output of a diode detector. At this point the carrier is already rectified to DC and needs only to be smoothed in the AVC filter. Note that the polarity of AVC voltage is shown as positive (+) since the transistors being controlled are of pnp type (Fig. 5).

In pnp semiconductors, a positive-going voltage applied to the base causes lower current and a reduction in amplification (the reverse of a tube circuit). You will also find transistor AVC which runs in the negative direction. This indicates an npn transistor is being controlled since its amplification decreases with the application of negative voltage.

Fig. 5 traces the major AVC points in a commercial solid-state circuit. Note that the carrier sample isn't trapped from the regular AM detector; instead, a separate AVC diode is connected to an earlier point in the receiver (see lower right of Fig. 5). This car receiver has an RF amplifier up front and it

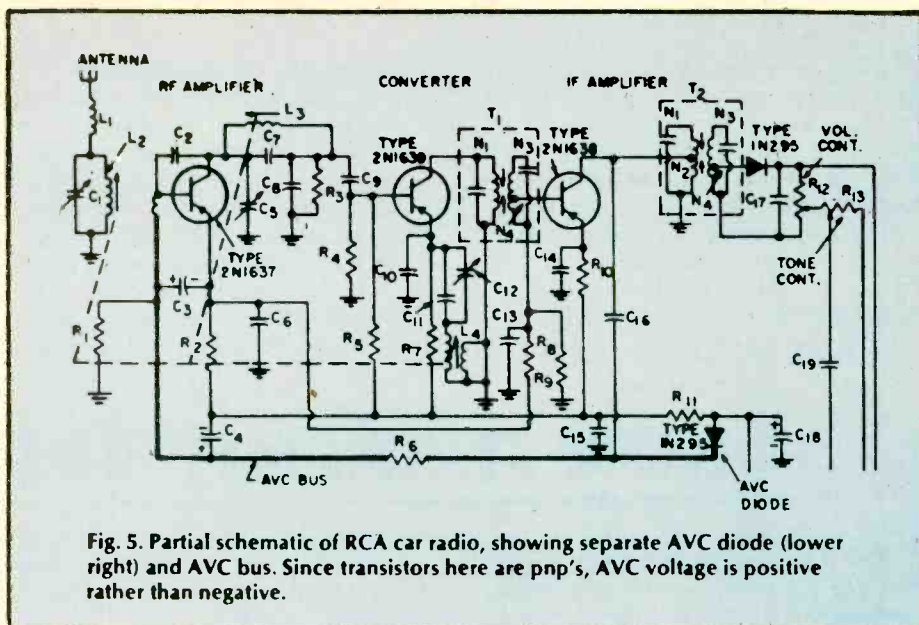

Fig. 5. Partial schematic of RCA car radio, showing separate AVC diode (lower right) and AVC bus. Since transistors here are pnp's, AVC voltage is positive rather than negative.

produces sufficient AVC voltage for the tap-off to occur at this early point. The remainder of the AVC bus resembles the tube circuit; the carrier is rectified, filtered, and applied back to the input stage. Since the RF transistor is a pnp type, an increasing carrier produces rising positive voltage and a consequent drop in transistor gain.

What's the Delay. AVC circuitry described to this point works well for table and other consumer type radios. But there's always something better. One improvement is *DAVC*, for delayed AVC, to overcome one disadvantage of regular AVC on weak signals. To operate at highest sensitivity, a receiver should run wide open, or at maximum amplification. The trouble occurs when a weak signal entering the receiver commences to generate a small, but effective, AVC voltage. AVC comes on too soon and receiver sensitivity is prematurely reduced.

In the delayed AVC scheme, AVC must first overcome some fixed reference voltage before it starts to reduce amplification in the receiver's front end. For example, a conventional receiver may start to generate AVC voltage

when a carrier of about 5 microvolts is in the antenna. A high-performance ham or communications set, though, might delay AVC action until the signal attains a strength of 10 microvolts.

Another improvement in deluxe receivers is amplified AVC, meaning the control voltage is boosted before being applied back to an earlier stage. This could produce AVC voltage swings of from 0 to 35 volts, instead of a more conventional range of 0 to 7 volts. The net result is better control of the receiver under dynamic changes in signal strength.

It's AGC, Too. Though AVC began as a technique for controlling average audio level, nearly identical concepts are applied in receivers which produce pictures, navigational read-outs, or other intelligence of a non-audio nature. Since latter-day AVC may no longer control volume, its designation changes to *AGC*, for Automatic Gain Control. Incidentally, this term is technically more accurate even for regular radios because it's receiver radio-frequency gain, *not* audio volume that's directly regulated. A good example of AGC is in TV receivers for keeping picture contrast reasonably constant over a wide swing of signal strength. Let's examine the TV signal in some detail because the method of generating a control signal is different from that of a radio.

The video carrier which brings the TV signal to the home is not a suitable source of AGC voltage. The picture carrier changes strength with lights and darks in the scene which happens to be on the screen during a particular moment. Back in our simple radio, we could filter out audio modulation fairly easily. However, video modulation can

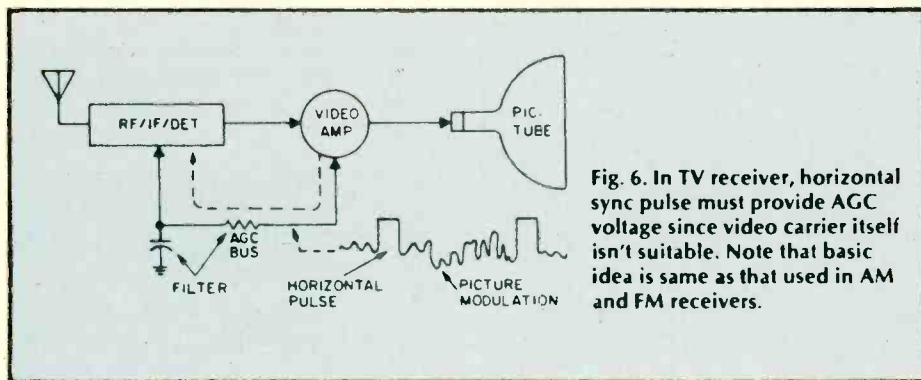

Fig. 6. In TV receiver, horizontal sync pulse must provide AGC voltage since video carrier isn't suitable. Note that basic idea is same as that used in AM and FM receivers.

receivers are envisioned as having response equal to that of stereo FM tuners, on the order of 15 kHz. The introduction of AM stereo will finally force AM broadcasters to pay attention to the range of audio frequencies they transmit. Likewise, equipment manufacturers will devote more attention to the AM section of AM/FM receivers. Current design practice seems to regard the AM

section almost as a necessary evil.

DXers will find themselves hunting for distant stations broadcasting in stereo, and the improved AM receivers will be a boon for CBB DXers. Other special equipment, such as directional CBB loop antennas, will likely become available. Yet the improved audio range of AM stereo stations will cause more co-channel interference and may make

digging out weak foreign stations on the "split" frequencies between the even 10 kHz frequencies a difficult task.

And even those who only tune the shortwave bands may not be left out—international shortwave broadcasts are AM, after all! Wouldn't you like to spend a cold winter evening listening to South Seas music from Radio Tahiti—in stereo? ■

HOW TRANSMITTERS WORK

□ One if by land, and two if by sea..." says the famous poem by Longfellow commemorating the midnight ride of Paul Revere in April of 1775. Revere's fellow patriot, who hung the two (if by sea) lanterns in the steeple of the Old North Church of Boston 200 years ago, was engaged in *communicating by modulation*, just as surely as today's CBER who presses the PTT switch on his microphone. For *modulation* simply means *variation*, or *change*—and it's modulation, whether you're changing the number of lanterns hanging in a church steeple, or using electronic circuitry to change the radio wave emitted by an antenna in accordance with your voice.

All communication is by modulation. For centuries, the American Indians sent messages by "modulating" a smoke stream with a wet blanket, and primitive tribes have long communicated by modulating the beat of their jungle drums. Later, semaphore flags were used to send messages by modulating their position. Even these words you are reading can be considered modulation of the surface of a piece of paper with spots of ink.

But almost all of today's long-distance instantaneous communication is carried out by modulating radio waves. In fact, this means of communicating is now so commonplace that even the Man the Street unknowingly refers to modulation when he speaks of "AM" and "FM". These familiar abbreviations stand for *Amplitude Modulation* and *Frequency Modulation*, respective-

ly, and refer to the two common methods of changing a radio wave to make it broadcast words or music from one place to another.

Introducing the Carrier. A radio wave broadcast from the antenna of a transmitter is, in the absence modulation by speech or music, an unchanging, constant sine wave, as shown in Fig. 1. It is as constant and as unchanging as the steeple of the Old North Church, and conveys no more information than a steeple. It simply gives you something to monitor for the possible later appearance of a signal.

Just as the steeple was a support or carrier on which to hang the information-giving lanterns, so the radio wave becomes the carrier upon which the speech or music is "hung". In fact, the unmodulated wave is usually referred to as the *carrier*.

The carrier may be shown as a simple sine wave, as in Fig. 1.

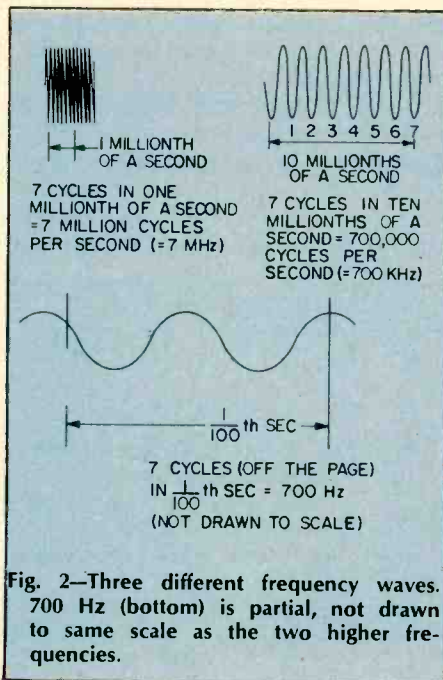

Fig. 2—Three different frequency waves. 700 Hz (bottom) is partial, not drawn to same scale as the two higher frequencies.

The height, or amplitude of the wave, indicates the strength of the signal, while the time it takes the wave to complete a certain number of cycles determines the spot on the radio dial where the signal will be received. For example, as shown in Fig. 2a if it takes only a millionth of a second for the carrier to complete seven cycles, then it will complete 7,000,000 cycles in one second, and the signal will appear on a receiver's dial at the 7,000,000-cycle-per-second (7-megahertz) point, which is on the edge of the 40-meter ham band. Such a carrier has a *frequency* of seven MHz.

On the other hand, a carrier taking longer to complete the same number of cycles—say, seven cycles in 10 millionths of a second (Fig. 2b)—would complete only 700,000 cycles in one second, and would be found on the dial at 700 kHz (700 thousand Hertz), which is in the standard broadcast band.

As can be seen from the above numbers, carrier frequencies are normally very high—much higher than the speech or music (audio) frequencies which we will cause the carrier to carry. For example, when a flutist plays the note F above middle C, he produces vibrations in the air which can be visualized as in Fig. 2c. Here, the time for 7 vibrations is only *one fiftieth* of a second, which is a frequency of only 350 cycles per second (350 Hertz).

But a constant (*unchanging*) carrier wave conveys no information. Something about the wave must be *varied*

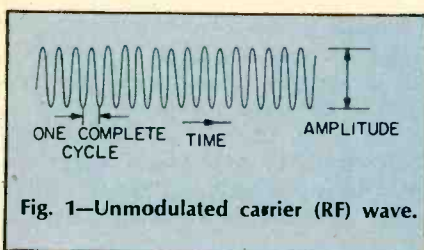

Fig. 1—Unmodulated carrier (RF) wave.

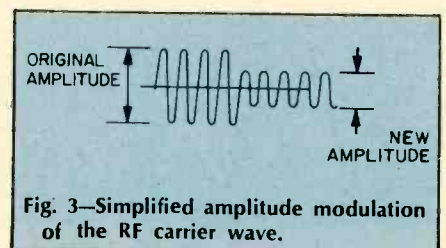

Fig. 3—Simplified amplitude modulation of the RF carrier wave.

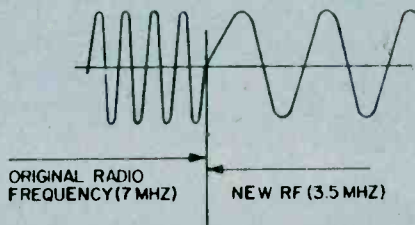

Fig. 4—Simplified frequency modulation of the RF carrier wave.

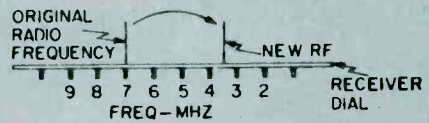

Fig. 5—If the frequency modulation were a simple change from one RF carrier frequency to another, an AM receiver could receive it if retuned.

(modulated) to convey information to the listener. What can be changed, so that the listener can recognize that a signal has been sent to him?

AM and FM. Looking again at Fig. 1, you can see that a carrier has two obvious characteristics—its height, or *amplitude*, and its *frequency*. Changing either of these can cause a receiver to recognize that a message has been sent. If the amplitude is changed, we call it *amplitude modulation*, or AM. If the frequency is changed, we call it *frequency modulation*, or FM.

A very simple type of AM is shown in Fig. 3. Here the amplitude of the carrier wave has been changed suddenly to half its former value.

This change in amplitude is a simple form of AM, and can convey simple messages. If Paul Revere had been a CBer, he could just as easily have pre-arranged a code signal which said "... one drop in carrier amplitude if by land; two drops in carrier amplitude if by sea ..." and served the American cause just as well (though Longfellow's poetry might have suffered).

The other obvious characteristic of

the carrier wave of Fig. 1 is its *frequency*. We can also modulate this characteristic, as shown in Fig. 4. Here, instead of a sudden change in amplitude, there is a sudden change in frequency, from 7 MHz to 3.5 MHz. This is a very simple form of FM, and can also be used to convey simple messages. Since the drop in frequency represents a shift in the carrier's location on the dial, as shown in Fig. 5, two receivers, one tuned to 7 MHz and the other to 3.5 MHz, could detect this shift in frequency, and the listener could interpret it as a signal, according to a pre-arranged code.

What's PM? While the Man in the Street has made AM and FM household phrases, these modulation methods are only two of the three ways a radio frequency carrier wave may be modulated. The third method, *Phase Modulation*, or *PM*, although virtually unknown to most people, is nonetheless extremely important in such fields as data transmission and color television.

Phase modulation can be visualized as in Fig. 6. Here, neither the amplitude nor the frequency is varied, but

the carrier is made to pause for a moment, and then to continue as a sine wave slightly delayed from the original. This delay is called a *phase shift*. Phase shift is usually measured in *degrees*. A phase shift equal to the time needed for an entire cycle is 360° . In the sketch, a sudden phase shift of about 70° (less than a quarter cycle) is indicated. By suitable receiver circuitry (found in every color TV receiver), this sudden change in phase can be interpreted as a signal. In color TV, it might represent a shift in hue from green to yellow.

Amplitude Modulation—A Closer Look. The sudden drop in amplitude shown in Fig. 3 is a good way to show the general scheme of AM, but it fails to tell us very much about how AM is used, every day, in our AM receivers and CB rigs. Here there are (hopefully) no sudden shifts in carrier amplitude, but instead, there is a remarkable re-creation of speech and music from a distant transmitter. How is this done?

To explain, let us assume that our flutist stands before a microphone in a broadcasting studio, ready to play his 350-Hz F-above-middle-C. Let's also

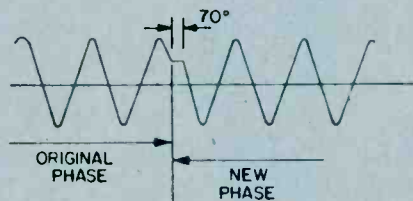

Fig. 6—Simplified phase modulation of the RF carrier wave.

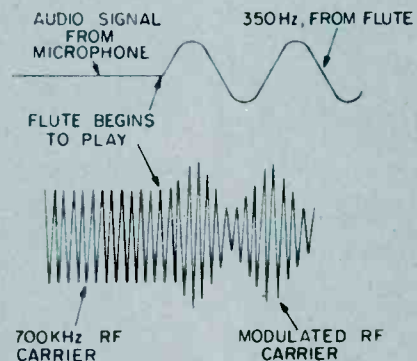

Fig. 7—The audio signal (sound) modulates the RF carrier wave.

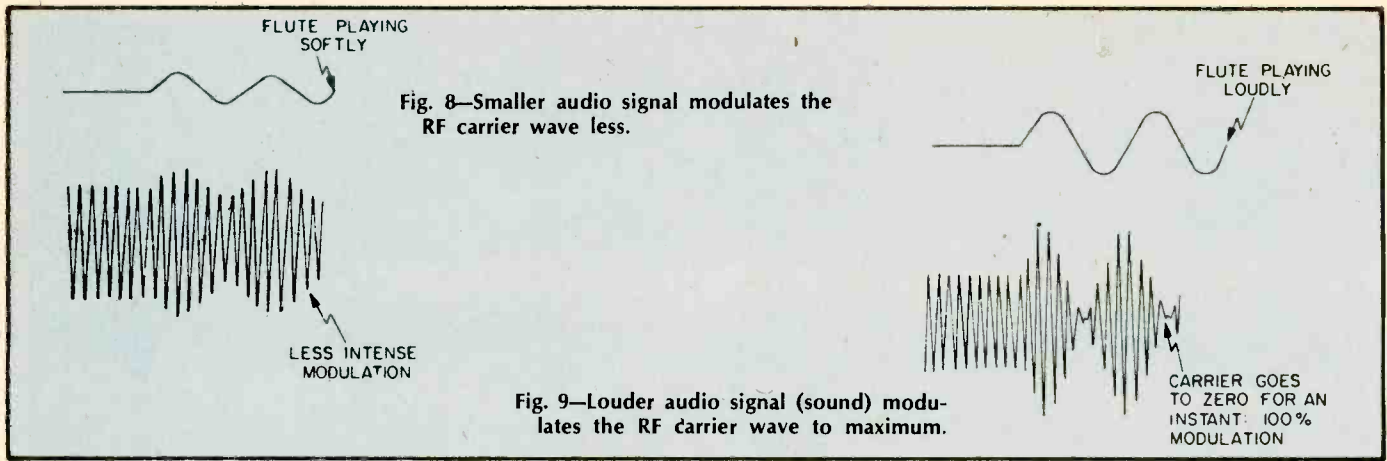

Fig. 8—Smaller audio signal modulates the RF carrier wave less.

Fig. 9—Louder audio signal (sound) modulates the RF carrier wave to maximum.

assume that the broadcasting station is assigned a carrier frequency of 700 kHz. Figure 7 shows how the carrier wave will appear just before the flutist plays, and just after he begins.

As you can see, the 350-Hz audio tone from the flute causes the amplitude of the carrier to rise or fall in accordance with the rise or fall of the flute wave. Note that both the top and bottom of the carrier wave are affected by the flute waveform. It is as though the carrier had been squeezed into a snug-fitting envelope, forcing it to conform to the waveform of the flute sound. The shape thus formed by the tips of the modulated carrier wave is often called the *envelope*.

The envelope of an amplitude-modulated carrier is therefore a good replica of the audio waveform coming from the studio microphone. Every shading, every change, in the sound striking the microphone will be faithfully traced out by the tips of the carrier wave. For

example, if the flutist were to play more softly, the result will be as in Figure 8. If he plays more loudly, Figure 9 is the result. You will note that in Fig. 9 the amplitude modulation is so intense that, at one point, the carrier's amplitude goes to zero for an instant. This is called 100% modulation, and represents the loudest sound AM can handle. If the flutist plays even *more* loudly, the result is as shown in Fig. 10. As the figure shows, the envelope is no longer a faithful replica of the original audio waveform, so the listener will receive a distorted sound. This condition is called *overmodulation*, and is undesirable.

Hardware for AM Systems. One of the most-straightforward methods of producing AM is the method invented by the Canadian Reginald Fessenden, in 1905. In his system, a radio frequency generator produced the carrier wave, which was fed to the antenna through a carbon (variable-resistance) microphone. See Fig. 11.

Since a carbon microphone varies its resistance in accordance with the speech or music, the microphone in this primitive system acted as a valve to allow more or less of the RF carrier wave to pass to the antenna. In this way the carrier wave broadcast by the antenna was amplitude modulated by the sound waves striking the microphone.

More Up-to-date Modulation Methods. Although nobody puts carbon microphones in series with antennas any more, the more modern modulation methods, such as those found in AM broadcast transmitters or CB transmitters are still rather similar to the primitive carbon-mike method. The typical modern AM system (Fig. 12), still employs an oscillator (which is crystal-controlled, to ensure that the carrier frequency is constant, and thus is found at a known spot on the dial), and a power amplifier to strengthen the carrier before feeding it to the antenna. The amount of "strengthening" is con-

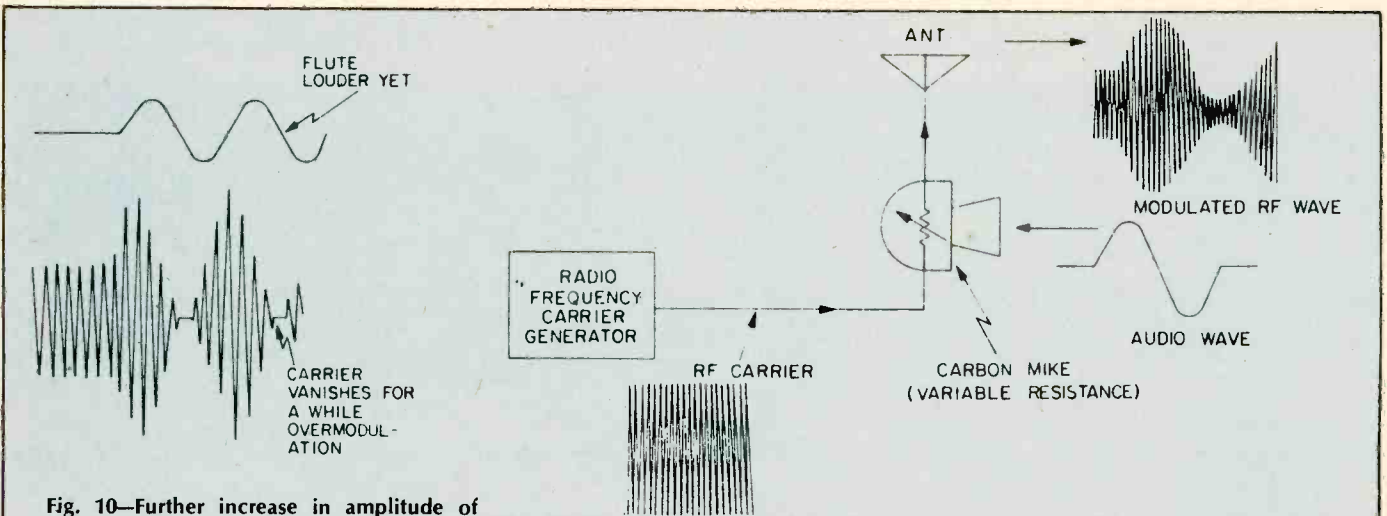

Fig. 10—Further increase in amplitude of audio signal causes overmodulation.

Fig. 11—The first radiotelephone broadcast transmitter, invented by Canadian Reginald Fessenden, who broadcast voice and music to a few ships at sea on Christmas Eve, 1905. It worked, but was very noisy.

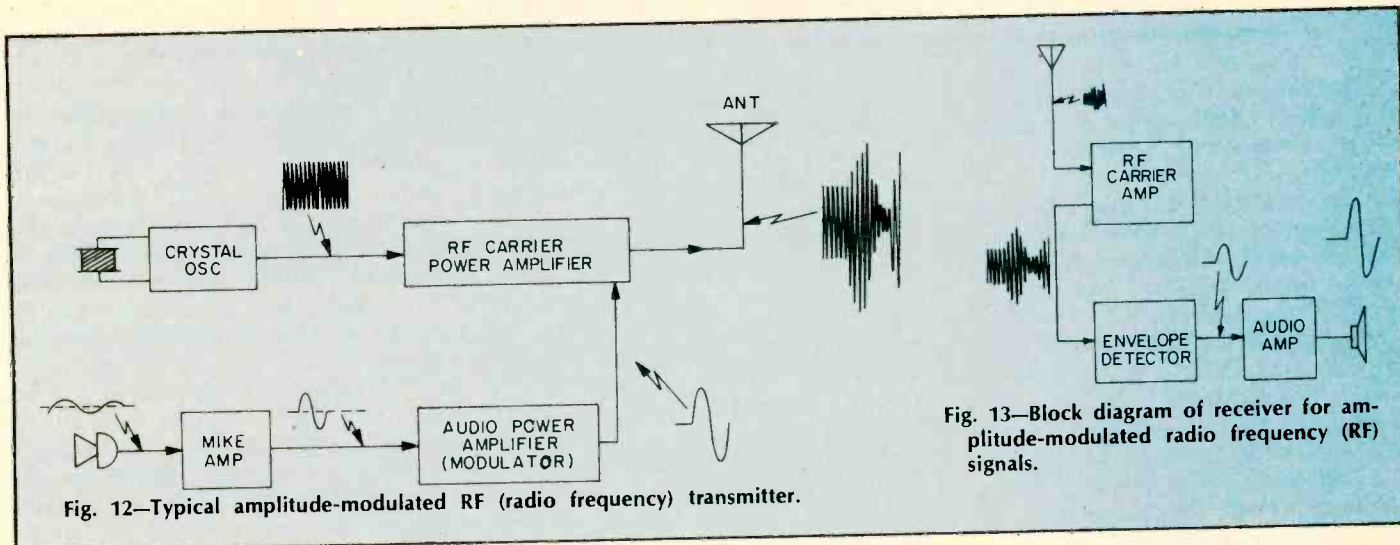

Fig. 12—Typical amplitude-modulated RF (radio frequency) transmitter.

Fig. 13—Block diagram of receiver for amplitude-modulated radio frequency (RF) signals.

trolled by the audio signal, and the music to a distant point.

Receiving the Signal. At that distant point, we all know that the carrier power delivered to the antenna is in this way amplitude-modulated and the radiated carrier will convey the speech or wave may be intercepted by a suitable antenna and applied to a receiver. A simple receiver is shown in block diagram form in Fig. 13. Here, the weak signal from the antenna is first ampli-

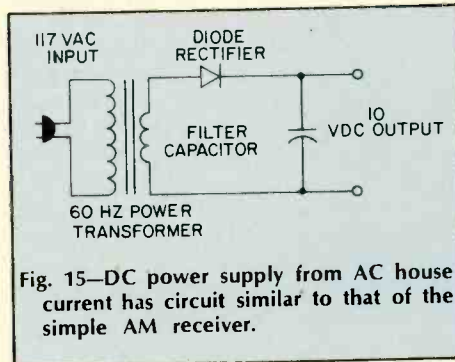

Fig. 15—DC power supply from AC house current has circuit similar to that of the simple AM receiver.

117 volts to 105 volts is *actually amplitude modulation*, of the 60-Hz input sine wave, and the drop in the output DC has "detected" the AM that occurred at the input! This is shown in Fig. 16.

So a simple AM detector may be thought of as a power supply arranged to change its output very quickly in accordance with the amplitude changes in the AC (carrier) at its input. And, since these fluctuations in amplitude of carrier represent the original audio signals, the "power supply" (detector) output will be the same as the original audio. It's interesting to note the power sup-

plied wave is further amplified and then fed to a loudspeaker, which re-creates the original speech or music.

The Detector—Heart of the Receiver. By looking at Fig. 13, you can see the detector is the heart of the AM receiver which extracts the original signal from the amplitude-modulated carrier. The circuit that does this job is surprisingly simple. It resembles very closely the circuit of a typical power supply. In an AC power supply, when 117-volts AC is applied at the input plug, a DC voltage appears at the output. If, because of a brown-out or for some other reason, the 117 volts at the input drops to, say, 105 volts, the DC output will drop correspondingly. In a power supply, this output drop is undesirable—we want the DC output to remain constant even though the input AC varies. Notice that the drop in voltage of the 60-Hz power line input from

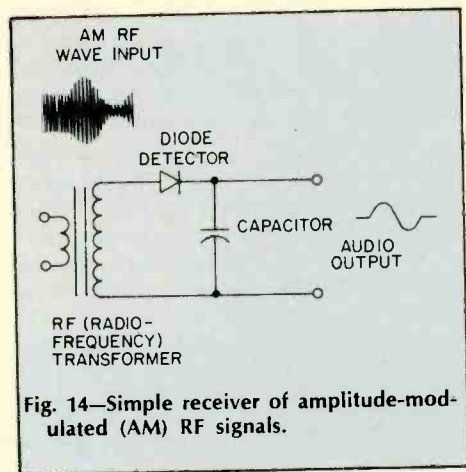

Fig. 14—Simple receiver of amplitude-modulated (AM) RF signals.

fied in a carrier-wave amplifier, (an RF (radio frequency) amplifier, and applied to a *detector* which can extract the original audio signal from the amplitude-modulated RF carrier. This au-

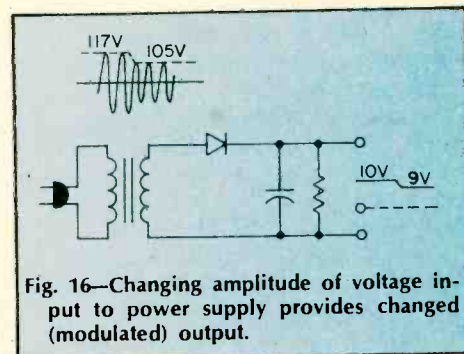

Fig. 16—Changing amplitude of voltage input to power supply provides changed (modulated) output.

ply's undesirable trait, unsteadiness in output when the input is unsteady, is the useful operating characteristic of the same circuit when used as a detector!

INSIDE YOUR POWER SUPPLY

□ The catalog of a leading electronics supplier contained this glowing description: A superhet shortwave receiver covering the standard broadcast band through 20 Meters. Its cabinet was luxurious walnut, its audio output push-pull into a high-quality speaker. The set boasted low current drain and the latest circuitry. The price?—a mere \$49.75.

The catalog was Allied Radio's and the date was 1932. The radio was a console meant for the living room, and it no doubt pulled in the A&P Gypsies with reasonable fidelity. The thing is, it required batteries for power.

Here's the battery complement for the handsome, but hungry. *Knight 8* vintage receiver: three 45-volt "B" batteries for tube plates; one 2-volt "A" cell for lighting filaments; one 22.5-volt "C" battery for biasing tube grids. This mountain of Evereadys cost \$9.00, a rather steep tab even in the good old days. And they could have pooped out right in the middle of a Herbert Hoover speech.

Super Supplies. That danger is gone, thanks to power supplies. Now a receiver takes raw electricity from the utility company and converts it to filament, plate, or bias voltages. It does the same for transistorized circuits. Or it perhaps participates in the growing trend to 3-way operation, where you use the same device at home, in a car, or carry it as a portable. The supply not only powers the equipment in the home, it also recharges the portable batteries. Cost is low because AC power is priced about 7¢ per kilowatt hour—which means you can operate a plugged-in table radio for about 100 hours on a few pennies per day.

Though power supplies operate circuits of vastly different voltage and current requirements, the basic principles are the same. In most instances a supply accepts house current—usually 117 volts AC alternating at 60 Hz (cycles)—and performs the following steps.

● **Transforming Voltage.** The power company provides 117 volts for home outlets, but it's hardly the value that many electronic devices demand. The plates of receiving tubes require about 100 to 250 volts for operation, while transmitting tubes may need a "B+" several hundred volts higher. Transistors, on the other hand, usually function at less than 30 volts. So the first task of the supply is to transform voltage to the

desired value. In many CB sets, for example, there's plate-voltage requirement of 250 and filament-voltage requirement of 12.6 VAC. The power transformer delivers these levels.

● **Changing AC to DC.** Furnishing correct voltage is not enough. Those voltages must often be DC—and the power company provides alternating current. So the second function of a supply is to *rectify*, or convert AC to DC. If a rectifier malfunctions in your radio you'll soon learn its function. The symptom is annoying hum in the speaker (caused by 60-Hz alternations in the audio). In a TV set, suffering rectifiers can put a thick, dark, "hum" bar across the screen.

● **Filtering.** Though rectifiers change AC to DC the product is far from suitable because it contains objectionable ripple. This will be attacked by the filter, which smooths the pulsations to pure DC.

The final step of the supply depends on the designer. He can add a *bleeder*, choose a *regulator*, or insert a *divider* at the output. We'll look at these extras, but first consider how the supply's basic parts operate.

The Transformer. In Fig. 1 is a typical power transformer that's been produced by the millions with only slight variations. As we'll see, the transformer acts to create a voltage change between its primary and various secondary windings. The trick's based on the turn-ratio between the various windings. If turns in the secondary number twice those of the primary, then output voltage doubles; if turns in the secondary are a fraction of those in the primary,

then a stepdown in voltage occurs.

Thus, in Fig. 1, the rectifier filament, which operates at 5 volts, has few turns compared to the primary; the high-voltage winding at 500 volts, however, has about five times as many turns as the primary. The colors shown for the windings, incidentally, are standard and observed by many transformer manufacturers.

The *centertap* connection of a winding splits the voltage in half. In our example, the high-voltage secondary is capable of 500 volts across the full winding (red to red), but only 250 volts between the centertap (red/yellow) and either end. The most important job for a centertap occurs in a *full-wave* supply, as we'll see in a moment. Note that a protective fuse and a power switch are located in one primary lead of the transformer.

Rectification. The two filament voltages from our transformer (5.0 for the rectifier and 6.3 for other tubes) will need no further processing. AC can be applied directly for filament heating (or for lighting pilot lamps on the front panel). High voltage, however, must be converted to DC before powering tube plates or transistor collectors and drains.

A circuit for changing AC and DC is a *half-wave* rectifier, shown in Fig. 2. It's based on a diode's ability to conduct current in only one direction. The rectifier cathode boils off electrons (negative) which are attracted to the plate when the plate is driven positive by incoming AC.

When the next half-cycle of the AC appears, the plate is driven negative, so electrons are repelled at this time. The

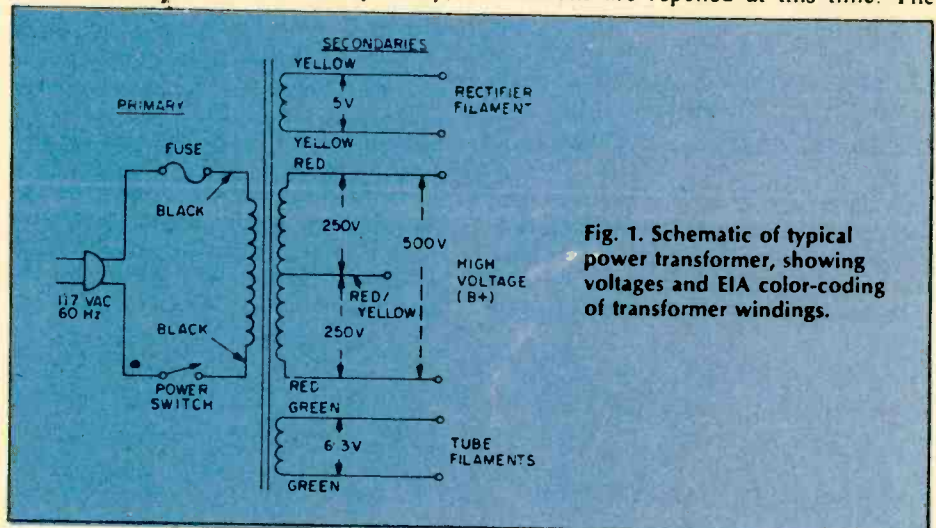

Fig. 1. Schematic of typical power transformer, showing voltages and EIA color-coding of transformer windings.

net result is shown in the output: a series of positive voltage pulses appearing at the load. (The dotted line shows where the negative side occurred.)

In practical circuits the half-wave rectifier is usually reserved for light-duty power supplies. It's inefficient because it fails to make use of AC voltage half the time (during the negative pulses). Secondly, those wide spaces between pulses are difficult to filter because of low ripple frequency. In a half-wave rectifier, the pulsations occur at 60 Hz, the same frequency as the applied line voltage. But don't underrate the half-wave supply because it's been used in just about every 4- or 5-tube table radio now playing. After all, its power requirements are low and the circuit is inexpensive to manufacture.

Full-Wave Supplies. Transmitters and higher-power equipment overcome the half-wave's shortcomings with the full-wave system. It's nothing more than a pair of diodes that are driven alternately so they consume every bit of AC input voltage. The key to full-wave operation is the centertap on the transformer's secondary winding. As applied AC appears across the complete winding, it makes the top end negative (as shown in Fig. 3) and the bottom end positive.

The centertap at this time establishes the zero voltage point because it's at the common, or grounded, side of the circuit. During the time the lower diode (No. 2) has a positive plate, it does the conducting. Next, the applied AC voltage reverses and makes the top diode plate (No. 1) positive so this tube now conducts.

This load-sharing combination of two diodes and a centertapped power transformer not only improves efficiency, but doubles the ripple frequency. An input of 60 Hz emerges as 120 Hz in a full-wave arrangement because every half-cycle appears in the output. This reduces the pulsating effect (cycles are closer together) and the DC becomes easier to filter.

If you purchase a transformer, watch out for one pitfall. It may be rated, say, "250 volts CT" and appear to be suitable for a rig with a 250-volt plate supply. In a full-wave supply, however, the transformer voltage output would be only 125, since a centertap reduces the voltage of a winding by one half. This can be avoided by specifying a transformer that has 250 volts *each* side of centertap or, stated another way, "500 volts CT."

Solid-State Rectifiers. Tube rectifiers are still widely found in electronic equipment, but they're destined for the Smithsonian Institution. Solid-state

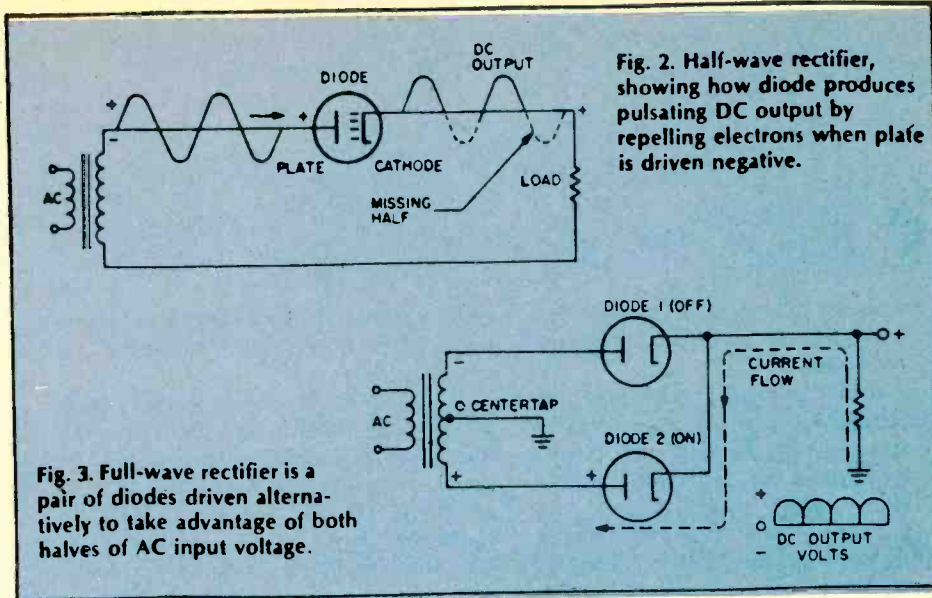
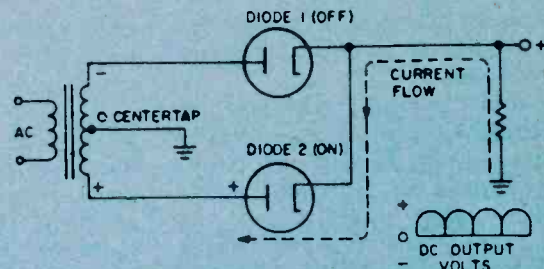

Fig. 3. Full-wave rectifier is a pair of diodes driven alternately to take advantage of both halves of AC input voltage.



equivalents are superior because they don't need filaments or heaters to accomplish the same rectifying action. They're several hundred times smaller and much cooler in operation. Instead of a huge 5U4 vacuum-tube rectifier in your TV set you're now more apt to find a pair of tiny silicon diodes.

Circuits using these semiconductors, though, are similar to those of vacuum tubes. As shown in Fig. 4, diodes can be used in equivalent half- and full-wave arrangements.

Unlike tubes, though, solid-state diodes rectify AC and DC by a semiconductor effect at the diode junction (a region between the anode and cathode). The action, in simplified fashion, occurs when "current carriers" in the material flow toward and away from the junction under the influence of applied AC. When few carriers appear at the junction, little current gets through the diode; conversely, when many carriers are in the area, they reduce the junction's opposition to current flow. Depending on the way the diode is connected in the circuit, it can recover either the positive or negative half of the AC.

Bridge Rectifiers. Another common arrangement is the full-wave bridge (Fig. 5). Though it uses four diodes, it offsets this disadvantage by an ability to produce the same output as a regular full-wave supply without a centertapped

transformer. It accomplishes the feat by operating one pair of diodes during each half cycle. And as one diode pulls current out of the load, its partner pushes current into it.

The net effect is a total voltage across the load which is about equal to the applied AC. We've shown how it occurs for diodes 1 and 2 in the diagram (Fig. 5) but a comparable action occurs in the other diodes when the AC switches polarity.

Filtering. The next major section of the supply is the filter, which smooths out the ripple. Its two major components are often a capacitor and a choke which eliminate pulsations by dumping a small amount of current from the peak of each ripple into the "valleys" between them. The result, as shown in Fig. 6, is pure DC fit for a tube or transistor.

In operation, pulsating DC arrives at the filter choke, a coil of wire wound on a soft iron core. As the name implies, the choke attempts to oppose any change in current flow. The rippling part of the wave, therefore, encounters high reactance in the choke and fails to get through. This is aided by the filter capacitor which is charged by ripple voltage.

As the ripple falls (between pulses), the capacitor discharges part of its stored current into the "valley." Thus the combined effect of choke and ca-

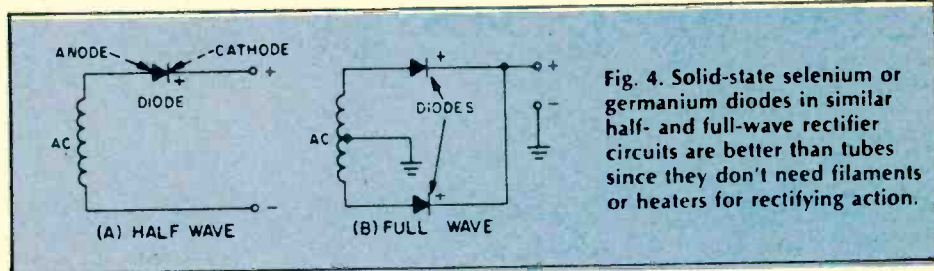

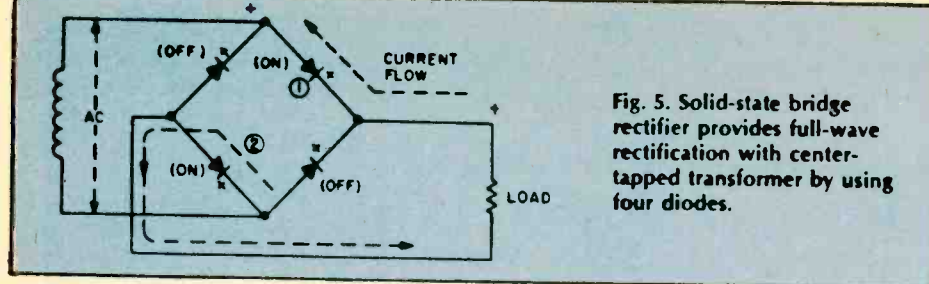

Fig. 5. Solid-state bridge rectifier provides full-wave rectification with center-tapped transformer by using four diodes.

capacitor results in smooth DC which can have ripple as low as a few percent of the total voltage.

You won't find the choke in some power supplies because it's an expensive item. Many designers eliminate it (especially in mass-produced equipment) by using a resistor instead, as shown in Fig. 7. The resistor does the job of filtering, but with one penalty: it reduces the amount of available voltage at the output. Yet, the loss can be tolerated in many circuits and filter resistors are common.

Another use for resistors in a supply is to serve as a *bleeder*, also shown in Fig. 7. In this function, it protects parts in the supply from possible damage due to sudden voltage surges when the supply is first turned on. Also, a bleeder helps stabilize voltage output when the load changes (as in a keyed ham transmitter) by always drawing some small degree of load current. Bleeders, too, are found in dangerous high-voltage circuits where they bleed-off the stored charge of filter capacitors that could deliver a lethal shock to a repairman (even after the equipment has been turned off.)

Note that a tap can be added to the bleeder to provide a second output voltage from the supply. Now the bleeder becomes a *voltage divider*. As such, it can supply the designer with multiple output voltages for operating various devices in a circuit.

Voltage Regulation. A ham who's received a "pink ticket" from the FCC for chirpy signals, a color TV that's gone fuzzy, a shortwave receiver that won't stay on frequency—all may suffer from a problem in voltage regulation. Line-voltage fluctuations or other electrical swings can cause poor, unstable

operation. So the engineers have come up with methods for "stiffening" a power supply.

If, say, line voltage changes from 105 to 130, they design the circuit to operate at 100 volts. Whatever voltage arrives over the line is reduced to 100, and the surplus is dumped (usually in the form of heat). To perform this task, the regulator establishes a reference point, then regulates around it.

A common example is the zener diode found in the power supply of many CB transceivers. Since these rigs can operate from a car's battery or generator, supply voltage can swing from 11 to 15 volts. This could happen if you're standing for a traffic light, then pull away, causing a shift between car battery and generator. If the CB set is on at this time, receiver tuning could be thrown off because of large changes in local oscillator voltage.

A zener diode can compensate for the shift, as shown in Fig. 8. At first glance it appears as an ordinary diode connected backward. Since the cathode (upper) terminal is connected to the positive side of the supply, there's a "reverse bias" condition. A zener diode, however, "breaks down" (or "avalanches") whenever its rated (zener) voltage is exceeded. In our example, the zener is a 9.1-volt unit, so the diode conducts current as the supply voltage shifts from 11 to 15 VDC.

Yet we see 9.1 volts indicated at the output. Secret of the zener's ability to hold at 9.1 is that it detours part of the supply current as the voltage increases. Since a resistor is in series with that current flow, a voltage drop (as shown) appears across the resistor. Thus, any increase in supply voltage is dissipated across the resistor and effectively sub-

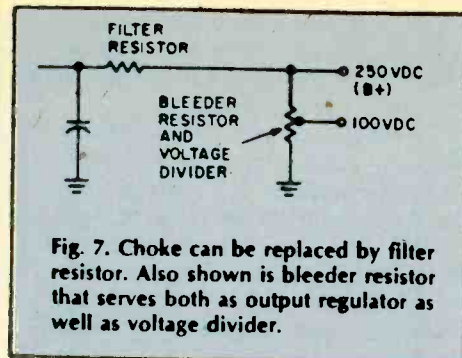

Fig. 7. Choke can be replaced by filter resistor. Also shown is bleeder resistor that serves both as output regulator as well as voltage divider.

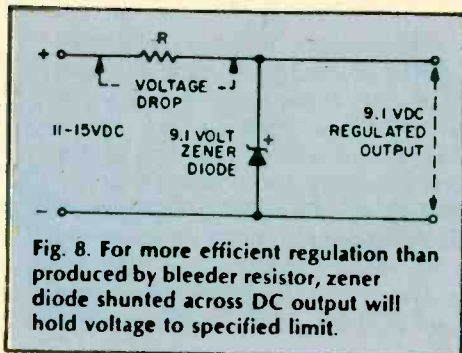

Fig. 8. For more efficient regulation than produced by bleeder resistor, zener diode shunted across DC output will hold voltage to specified limit.

tracted from the output. This automatic and continuous action occurs for any voltage above 9.1—the zener's nominal rating—so the output is said to be regulated.

Fusing Power Supplies. You can protect your power supply by installing a fuse or circuit breaker on the primary or secondary side of the transformer. A fused primary gives good overall protection but does not have the sensitivity needed for some circuits. By installing a fuse between the transformer's secondary center tap and ground you can improve fusing sensitivity. In solid state circuits the value of the fuse is all-important due to the low voltages involved, but since fuses do not react fast enough to save a transistor or IC chip you might have to resort to semiconductor protection such as using a zener diode.

More and Merrier. This barely brushes the subject of power supplies, since the variations are nearly endless. More than 20,000 volts for the picture tube of a color TV are derived from a special "flyback" transformer. It captures voltage from rapidly moving magnetic fields in the set's horizontal scanning section. An oscilloscope power supply contains strings of adjustable voltage dividers to move the pattern of light on the screen in any direction.

There are also high-current supplies with massive rectifiers for battery charging and super-smooth lab supplies for circuit design. But behind most of them are the simple principles which transform, rectify, filter, and regulate a voltage so it can do the job at hand. ■

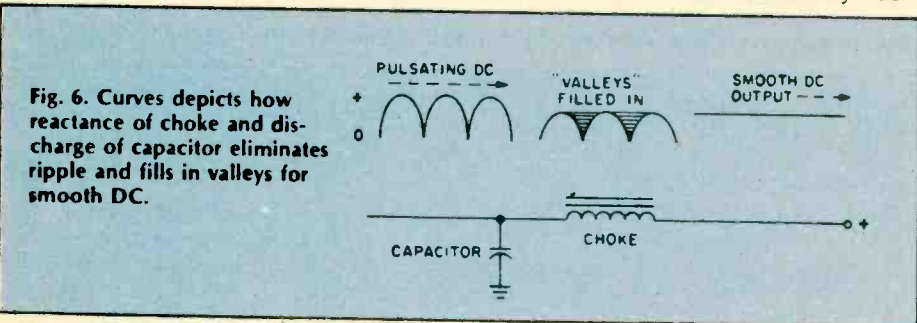

Fig. 6. Curves depicts how reactance of choke and discharge of capacitor eliminates ripple and fills in valleys for smooth DC.

UNDERSTANDING ELECTRONICS

One of the most thought-provoking discoveries of modern physics is the fact that matter and energy are interchangeable. Centuries of scientific headscratching about the nature of matter, the mystery of fire, and the once-terrifying crack of lightning have all come to focus on the smallest particle that is the building block of any given substance: the atom. An atom is necessarily matter and yet this atom of matter can undergo nuclear fission and release quantities of energy that are beyond the imagination. In the atom lies the secret of all phenomena.

By the beginning of the 19th century, the atomic theory of matter—which actually originated in 5th century Greece when the atom was named—was firmly established. It was due primarily to the efforts of 17th century scientists who—actually working in the tradition of medieval alchemy—sought the prime constituent of all matter. Mainly through the work of John Dalton, whose investigations as to how various elements combine to form chemical compounds, it came to be regarded that *an atom* was the indivisible and indestructible unit of matter.

This viable and working view of the indestructible atom served science until 1897 when the atom itself was found to be destructible! To anyone concerned with electricity or electronics, the year 1897 is a memorable

version of a cathode ray tube—the modern version of which is in almost every home today in the form of the television picture tube. Before Thomson's experiment, it was discovered that when electric current was passed through a gas in a discharged tube, a beam of unknown nature traveled through the tube from the negative to positive terminal (opposite to the direction conventionally held as the direction of the flow of current).

This "cathode ray" beam also traveled in a straight line and was deflected by electric or magnetic forces applied perpendicular to the beam. What Thompson did was to use these facts to determine for one of the mysterious particles comprising the beam of cathode rays the relationship of its mass, m , to its electric charge, e . By deflecting the beam with a known electric force (Fig. 1) and then measuring what magnetic force applied in the opposite direction would bring the beam back to its original undeflected position, Thompson could determine the relationship of e to m . He established a definite value for e/m and thereby "discovered" the electron which as we now know, is 1,837 times smaller in mass than the lightest atom, the hydrogen atom. It also carries the smallest charge that occurs in nature; every electric charge is actually an integral multiple of the charge of the electron.

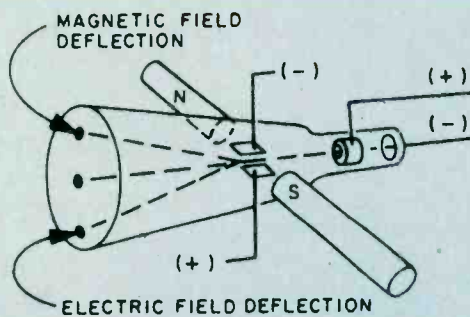

Fig. 1. Electron beam, like that in a TV picture tube (CRT), can be deflected magnetically or by an electric field. Force needed "measured" the electron.

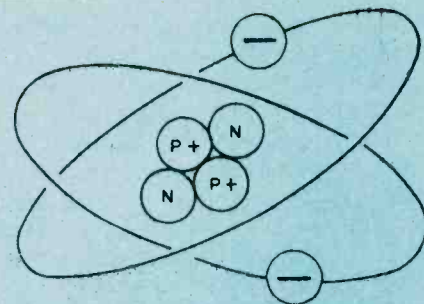

Fig. 2. Charge of each electron balances that of a proton. Other particles affect atomic mass but can be omitted in study of electronics.

one: it was the year J. J. Thomson, the English physicist, identified and experimentally revealed the existence of the first subatomic particle—the *electron*!

The First "Electronic" Experiment. We blithely speak of electricity as the flow of electrons yet, often, we are little aware of the great body of research that went into elucidating this fundamental of basic electricity. In fact, before the discovery of the electron, convention held that the flow of electric current was in the direction that a positive charge moved. This convention of *positive current*, being the flow of positive charges and opposite to the direction of electron flow, is still found to be useful in circuit analysis and is used even today.

Thomson's experiment established that a particle much lighter than the lightest atom did indeed exist. The electron, as it was named, was the first subatomic particle to be defined.

The experiment was conducted utilizing a rudimentary

From Minus to Plus. With the discovery of the electron, it was still over a dozen years into the 20th century before a graphic conception of the atom evolved. Since the atom is electrically neutral and electrons are negatively charged, the existence of positively charged particles was a necessity, and the existence of a *proton* was postulated. Eventually the nuclear model of the atom was evolved. Each atom was conceived to resemble a solar system in miniature. The nucleus—positively charged—is surrounded by a number of electrons revolving around it; the charges balance and the atom is electrically neutral (Fig. 2). Further research in the 20th century has gone on to reveal more elementary particles than you can shake a stick at: neutrons, positrons, neutrinos, mesons, quarks, and more. The number continues to grow and yet the ultimate nature of matter remains a riddle. But, in a discussion of basic electricity, only the electron and

proton need concern us.

Electrons in Orbit. An atom of matter has a number of electrons orbiting around its nucleus. A hydrogen atom for example, has a single electron; carbon on the other hand has six. These electrons are arranged in rings or shells around the central nucleus—each ring having a definite maximum capacity of electrons which it can retain. For example, in the copper atom shown in Fig. 3 the maximum number of electrons that can exist in the first ring (the ring nearest the nucleus) is two. The next ring can have a maximum of eight, the third ring a maximum of 18, and the fourth ring a maximum of 32. However, the outer ring or shell of electrons for any atom cannot exceed eight electrons. However, heavier atoms may have more than four rings.

The Outer Orbit. The ring of electrons furthest from the atom's nucleus is known as the *valence ring* and the electrons orbiting in this rings are known as *valence electrons*. These valence electrons, being further from the nucleus, are not held as tightly in their orbits as electrons in the inner rings and can therefore be fairly easily dislodged by an external force such as heat, light, friction, and electrical potential. The fewer electrons in the valence ring of an atom, the less these electrons are bound to the central nucleus. As an example, the copper atom has only one electron in its valence ring. Consequently, it can be easily removed by the application of only the slightest amount of external energy. Ordinary room temperature is sufficient to dislodge large numbers of electrons from copper atoms; these electrons circulate about as free electrons. It is because of these large numbers of free electrons that copper is such a good electrical conductor. There could be no electrical or electronics industry as we know it today if it were not for the fact that electrons can fairly easily escape, or be stripped from the valence ring of certain elements we refer to as "conductors."

Electronic Charges. If an electron is stripped from an atom, the atom will assume a positive charge because the number of positively charged protons in its nucleus now exceeds the number of negatively charged orbiting electrons. If, on the other hand, the atom should gain an electron, it will become negatively charged as the number of electrons now exceeds the protons in its nucleus. The atom with the deficiency of electrons is

known as a *positive ion*, while an atom with a surplus of electrons is known as a *negative ion*.

Presence of an electrical charge on a body can be illustrated by use of an electroscope (Fig. 4). Two leaves of aluminum or gold foil hang from a metal rod inside a glass case so they're free from air disturbances. When the metal rod is touched by a charged body, the leaves acquire static electricity of the same polarity and, since like charges repel, they stand apart. The greater the charge, the further apart the leaves spread.

Electron Flow. When an electrical conductor is placed between these two oppositely charged bodies, free electrons are attracted by the positive body—free electrons will move through the wire. This movement of free electrons will continue only until the excess of electrons is equally divided between the two bodies. Under these conditions, the charges on both bodies will be equal and the electron flow will end.

In Fig. 5 are a battery, lamp, and connecting leads between the battery and lamp. In this instance, the battery serves as an electric charge pump—free electrons continually developed at its negative terminal by chemical action flow through the connecting leads and lamp back to the positive terminal of the battery by the attraction of oppositely charged bodies. The battery, connecting leads, and lamp form an electrical circuit which must be complete before the free electrons can flow from the battery's negative terminal to its positive terminal via the lamp. Thus, the battery serves as a source of potential difference or voltage by continually supplying a surplus of electrons at its negative terminal. Summing up, we can say a flow of electric current consists of the movement of electrons between two oppositely charged bodies.

We cannot progress very far into the study of electricity without first becoming familiar with the basic properties of electrical circuits. Just as we define distance in feet and inches, so do we define electrical properties in specific terms and units.

Potential. Earlier, we saw that an electric charge difference has to exist between the ends of an electrical conductor in order to cause a flow of free electrons through the conductor. This flow of electrons constitutes the electric current. The electric charge difference, or potential difference, exerts a force on the flow of free

Fig. 3. The number of electrons to each ring are limited—2 in first; 8 in second; 18 for the third; and a total of 32 in fourth orbital ring. The last ring of electrons cannot have more than eight electrons.

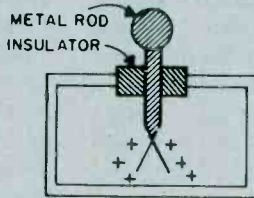
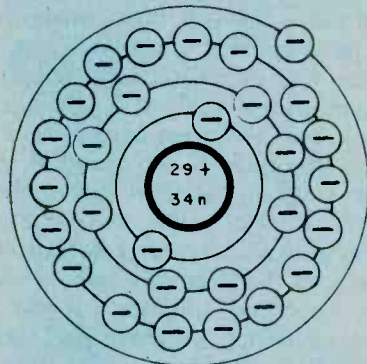
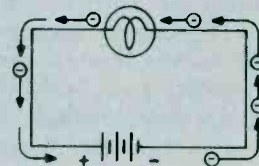

Fig. 4. Electroscope is a simple device to indicate electrical charges that are too weak to be measured with standard meters. The two leaves of gold foil pushed apart in the presents of a charged surface.

Fig. 5. Electron flow in any circuit is from negative to positive.



electrons, forcing them through the conductor. This electric force of pressure is referred to as electromotive force, abbreviated EMF.

The greater the charge or potential difference, the greater will be the movement of free electrons (current) through the conductor as there will be more "push and pull" on the free electrons. The symbol used to designate electrical potential is the letter E which stands for electromotive force. The quantity of EMF is measured by a unit called the volt. Hence, the common name most often used in place of EMF is *voltage*.

Current Intensity. We have learned that an electric current consists of a flow of charge carriers (generally free electrons) between two points of different electrical potential. The rate of flow of these charges determines the intensity or strength of this current flow. Current strength is expressed in units known as *amperes*. One ampere of current flows in a circuit when 6,240,000,000,000,000 electrons flow out of a negative terminal, through a conductor, and back into a positive terminal in one second. The symbol for the ampere is the letter *I* which stands for intensity.

Resistance. The flow of electric current through a conductor is caused by the movement of free electrons present in the atoms of the conductor. A bit of thought then indicates that the greater the number of free electrons present in the atoms of a particular conductor, the greater will be its electrical conductivity. Gold, silver, and copper rank as excellent electrical conductors, as their atoms readily release free electrons. On the other hand, the atoms of such elements as sulphur have almost no free electrons available and they are thus very poor electrical conductors. Such materials are known as electrical insulators. Between these extremes lie elements such as carbon whose atoms have a moderate number of free electrons available and thus are moderately good electrical conductors.

Even the best electrical conductors offer some opposition to the passage of free electrons. This opposition is called resistance. You might consider electrical resistance similar to mechanical friction. As in the case of mechanical friction, electrical resistance generates heat. When current flows through a given resistance, heat is generated; the greater the current flow, the greater the heat. Also, for a given current flow, the greater the resistance, the greater the heat produced.

Electrical resistance can be both beneficial and undesirable. Toasters, electric irons, etc. all make use of the heat generated by current flowing through wire coils. Resistance is also often intentionally added to an electrical circuit to limit the flow of current. This type of resistance is generally lumped together in a single unit known as a resistor.

There are also instances where resistance is undesirable. Excessive resistance in the connecting leads of an electrical circuit can cause both heating and electrical loss. The heating, if sufficient, can cause a fire hazard, particularly in house wiring, and the circuit losses are a waste of electrical power.

Electrical resistance is expressed by a unit known as the *ohm*, indicated by the letter *R*. An electrical conductor has a resistance of *one ohm* when an applied EMF of *one volt* causes a current of *one ampere* to flow

through it.

Resistance Factors. There are other factors beside the composition of the material that determine its resistance. For example, temperature has an effect on the resistance of a conductor. As the temperature of copper increases, for example, its resistance increases. The increase in temperature causes the electrons in the outer ring of the atom to resist release to the free electron state. This increase in resistance is known as a *positive temperature coefficient*. Not all conductors show this increase in resistance with an increase in temperature; their resistance decreases with an increase in temperature. Such materials are said to have a *negative temperature coefficient*. Certain metallic alloys have been developed which exhibit a *zero temperature coefficient*: their resistance does not change with changes in temperature.

As you might suspect, the length of a conductor has an effect upon its resistance. Doubling the length of a conductor will double its resistance. By the same token, halving the length of a conductor will cut its resistance in half. Just remember that the resistance of a conductor is *directly proportional* to its length.

The cross-sectional area of a conductor also determines its resistance. As you double the cross-section of a conductor, you halve its resistance; halving its cross-section doubles its resistance. Here again, the "why" of this is pretty easy to see: there are more current carrying electrons available in a large cross-section conductor than in a small cross-section conductor of the same length. Therefore, the resistance of a conductor is *inversely proportional* to its *cross-sectional area*.

Circuit Relationship. Now that we have a basic understanding of voltage, current, and resistance, let's take a look at just how they interact under circuit conditions.

Fig. 6. In A, B, and C, the value of the resistor remains constant while the supply voltage is altered with a resulting current change.

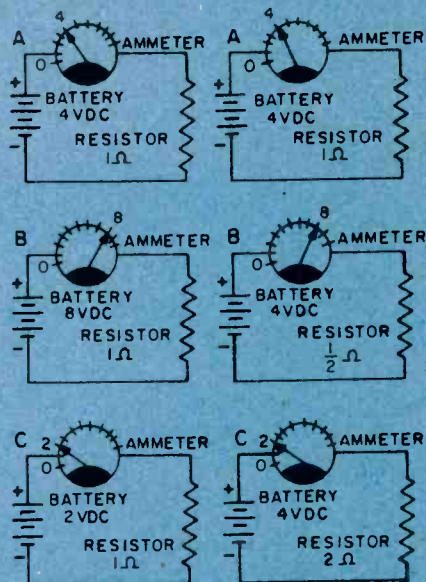

Fig. 7. Battery voltage A, B, and C is held constant while resistor is halved and doubled in value. Resulting current changes are basis for Ohm's law.

Fig. 6A shows a battery, ammeter (a device to indicate current strength), and resistor connected in series. Notice that the ammeter indicates that 4 amperes are flowing in the circuit.

Fig. 6B shows the identical setup with the exception that the battery voltage has now been doubled. The ammeter now shows that twice the original current, or 8 amperes, is now flowing in the circuit. Therefore, we can see that doubling the voltage applied to the circuit will double the current flowing in the circuit.

In Fig. 6C the same circuit appears again; this time, however, the battery voltage is one half its original value. The ammeter shows that one half of the original current, or 2 amperes, is now flowing in the circuit. This shows us that halving the voltage applied to the circuit will halve the current flowing through the circuit.

All this boils down to the fact that, assuming the same circuit resistance in all cases, *the current flowing in a circuit will be directly proportional to the applied voltage*—increasing as the voltage is increased, and decreasing as the applied voltage is decreased.

In Fig. 7A we again see the circuit consisting of the battery, ammeter, and resistance. Notice that the ammeter indicates that 4 amperes are flowing through the circuit.

In Fig. 7B we see that the value of resistance has been cut in half and as a result, the ammeter indicates that twice the original current, or 8 amperes, is now flowing in the circuit. This leads us to the correct assumption that for a given supply voltage, halving the circuit resistance will double the current flowing in the circuit.

Fig. 7C again shows our basic circuit, but with the resistance now doubled from its original value. The ammeter indicates that the current in the circuit is now one half of its original value.

Summing things up: for a given supply voltage, *the current flowing in a circuit will be inversely proportional to the resistance in the circuit.*

Ohm's Law. From what you have seen so far, you are probably getting the idea that you can determine the current flowing in a circuit if you know the voltage and resistance present in the circuit, and the voltage if you know the current and resistance, or the resistance if the voltage and current are known.

Fig. 8. Shaded portion of triangle indicates unknown quantity in the formula. Visible factors appear in their proper mathematical relation. Just fill in the known values and go on with multiplication or division.

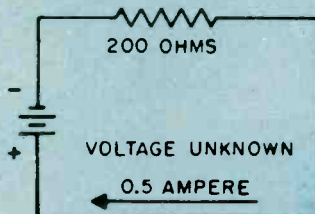
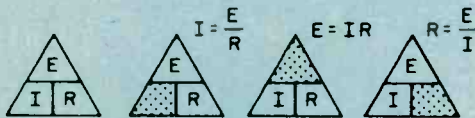

Fig. 9. Unknown quantity, voltage, found easily by applying Ohm's law.

All this is quite correct, and if formally stated by Ohm's law as follows:

$$I = \frac{E}{R}$$

Where: E = voltage (volts)

I = current (amperes)

R = resistance (ohms)

Now, let's take a look at how this formula is used:

To find voltage:

$$E \text{ (voltage)} = I \text{ (current)} \times R \text{ (resistance)}$$

To find current:

$$I \text{ (current)} = \frac{E \text{ (voltage)}}{R \text{ (resistance)}}$$

To find resistance:

$$R \text{ (resistance)} = \frac{E \text{ (voltage)}}{I \text{ (current)}}$$

A handy way to remember Ohm's law is by means of the triangle shown in Fig. 8. Simply cover the quantity (voltage, current, or resistance) that you want to determine, and read the correct relationship of the remaining two quantities. For example, if you want to now the correct current (I), put your finger over I and read E/R. Covering E or R will yield I × R or E/I, respectively.

Ohm's Law to Determine Voltage. Let's delve a bit more deeply into Ohm's law by applying it to a few cases where we want to determine the unknown voltage in an electrical circuit. Take a look at Fig. 9, which shows a simple series circuit consisting of a battery and resistor. The value of this resistor is given as 200 ohms, and 0.5 ampere of current is flowing through the circuit. We want to find the value of battery voltage. This is easily done by applying Ohm's law for voltage as follows:

$$E = I \times R$$

Let's go through this again, this time using a practical illustration. Fig. 10 shows a string of light bulbs, the total resistance of which is 400 ohms. You find that the bulbs draw 0.3 amperes when lighted. Let's say you would like to operate this string of bulbs from the standard 120-volt house current, but you don't know the voltage rating of the individual bulbs. By using Ohm's law for voltage, you can easily determine the voltage to light the bulbs as follows: (unknown voltage) = 0.3 (amperes) × 400 (bulb resistance) = 120 volts.

A word of caution. When cool, the resistance of a filament light bulb is much lower than when heated. As the filament is heated, the resistance increases due to positive temperature coefficient of the material as discussed earlier.

Ohm's Law to Determine Current. Now, let's take a look at a few examples of how to determine the value of unknown current in a circuit in which both the voltage and resistance are known.

Fig. 11 shows a series circuit with a battery and resistor. The battery voltage is 20 volts DC and the value of resistance is 5 ohms. How much current is flowing through the circuit?

$$\text{Ohm's law for current: } I = \frac{E}{R}$$

$$I = \frac{20 \text{ (battery voltage)}}{5 \text{ (resistance in ohms)}}$$

$$I = 4 \text{ amperes}$$

You will note that the 15 ampere fuse will not blow in this circuit.

Again to get a bit more practical, let's take a look at Fig. 12. Here we see an electric heater element connected to the 120-volt house line. We know that this particular heater element has a resistance of 20 ohms when hot. The house current line is fused with a 15-ampere fuse. We want to know whether the heater will draw sufficient current to blow the fuse. Here's how to find this out by use of Ohm's law for current.

$$I = \frac{120 \text{ (line voltage)}}{20 \text{ (Heater resistance in ohms)}}$$

$$I = 6 \text{ amperes}$$

We find from the above use of Ohm's law for current that the heater draws 6 amperes, so it can be safely used on the line fused with the 15-ampere fuse. In fact, a 10-ampere fused line can also do the job.

Ohm's Law to Determine Resistance. Ohm's law for resistance enables us to determine the unknown value of resistance in a circuit. Fig. 13 again shows a simple series circuit with the battery voltage given as 20 volts and the current flowing through the circuit as 0.5 ampere. The unknown resistance value in this circuit is found as follows:

Ohm's law for resistance:

$$R = \frac{E}{I}$$

$$R = \frac{20 \text{ (battery voltage)}}{0.5 \text{ (current in amperes)}}$$

$$R = 40 \text{ ohms}$$

Fig. 14 is a practical example of how to determine unknown resistance. Here, we want to operate a 6-watt light bulb from the 120-volt house line. What value of series dropping resistor do we need to drop the 120-volt

house current down to 6 volts? The bulb draws 0.2 ampere when illuminated (hot).

We must first determine the voltage which must be dropped across the series dropping resistor. This is done by subtracting the line voltage (120) from the bulb's voltage (6). This gives us a value of 114 volts which we use in conjunction with Ohm's law for resistance as follows:

$$R = \frac{114 \text{ (voltage drop)}}{0.2 \text{ (current in amperes)}}$$

$$R = 570 \text{ ohms}$$

Resistance in Series. Many practical electrical and electronic circuits use two or more resistances connected in series. The point to remember in this case is that the total resistance is the sum of the individual resistances.

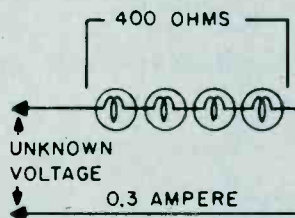

Fig. 10. Although problem looks different the basic circuit is same as that for Fig. 9.

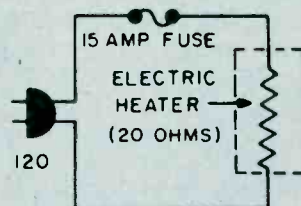

Fig. 11. Formula needed here is different since current is unknown. Just look for triangle in Fig. 8 that has I shaded.

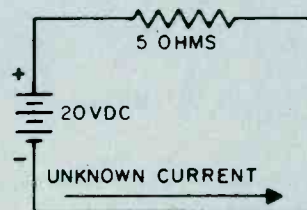

Fig. 12. Basic circuit is same as that in Fig. 11. Although three factors are given, current is unknown quantity.

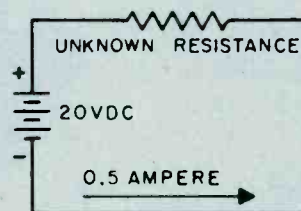

Fig. 13. Most Ohm's law problems are simple series circuits or can be reduced to simple series circuits.

This is expressed by the formula:

$$R \text{ (total resistance)} = R_1 + R_2 + R_3 + \text{etc.}$$

where R_1, R_2, R_3 , etc. are the individual resistances. Thus, in Fig. 15 the total of the individual resistances is $R \text{ (total)} = 40 + 6 + 10 + 5 = 61 \text{ ohms}$.

Resistance in Parallel. Resistances may also be connected in parallel in a circuit as in Fig. 16. In this case the current flowing in the circuit will divide between the resistances, the greater current flowing through the lowest resistance. Also, the total resistance in the circuit will always be less than the smallest resistance since the total current is greater than the current in any of the individual resistors. The formula for determining the combined resistance of two parallel resistors is:

$$R \text{ (total)} = \frac{R_1 \times R_2}{R_1 + R_2}$$

Thus, in Fig. 16 the effective resistance of R_1 and R_2 is:

$$R \text{ (total)} = \frac{2 \times 4}{2 + 4} = \frac{8}{6} \text{ or } 1.33 \text{ ohms.}$$

In a circuit containing more than two parallel resistors as in Fig. 17 the easiest way to determine the total circuit resistance is as follows: first, assume that a 6-volt battery is connected across the resistor network. Pick a value that will make your computations simple. Then determine the current flowing through each of the resistors using Ohm's law:

$$I = \frac{E}{R_1} = \frac{6}{2} = 3 \text{ amperes}$$

$$I = \frac{E}{R_2} = \frac{6}{3} = 2 \text{ amperes}$$

$$I = \frac{E}{R_3} = \frac{6}{6} = 1 \text{ ampere}$$

Next, add the individual currents flowing through the circuit:

$$I = 2 \text{ amp.} + 3 \text{ amp.} + 1 \text{ amp.}$$

$$I = 6 \text{ amperes.}$$

Inserting this 6 amperes in Ohm's law, the total circuit resistance is found to be:

$$R = \frac{6}{6} = 1 \text{ ohm.}$$

The combined equation for determining the total

resistance of n number of resistances in parallel would be:

$$\frac{1}{R} = \frac{1}{R_1} + \frac{1}{R_2} + \frac{1}{R_3} + \dots + \frac{1}{R_n}$$

Quite often an electronic circuit will contain a combination of series and parallel resistances as in Fig. 18. To solve this type of problem, first determine the combined resistance of R_2 and R_3 :

$$R \text{ (total)} = \frac{6 \times 12}{6 + 12} = \frac{72}{18} = 4 \text{ ohms.}$$

This total value of R_2 and R_3 may be considered a single resistance which is in series with R_1 , and forms a simple series circuit. This simple series circuit is solved as follows:

$$R \text{ (total)} = 6 + 4, \text{ or a total of } 10 \text{ ohms.}$$

Power. The amount of work done by electricity is termed the *watt* and one watt is equal to one volt multiplied by one ampere. This may be expressed as: $P = E \times I$ where E = voltage in volts, I = current in amperes. Also:

$$P = \frac{E^2}{R} \text{ and } P = I^2 R$$

As an example, assume that a toaster draws 5 amperes at an applied voltage of 115 volts. Its wattage would then be:

$$P = 115 \times 5 = 575 \text{ watts.}$$

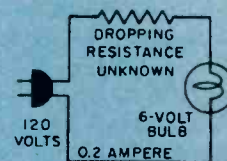

Fig. 14. This Ohm's law problem is somewhat more complex.

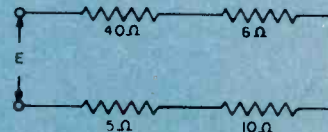

Fig. 15. Resistance in series is added. As far as voltage applied and current flow is concerned the individual resistors are only one.

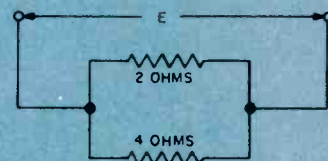

Fig. 16. Resistors in parallel are added algebraically—the result will always be a value less than that of the lowest in the circuit.

Magnetism and the Electron. The atom and a concept of its structure were a necessary preface to our discussion of basic electricity. By the same token, both are necessary to understanding basic magnetism.

As we've mentioned, electrons are in continual motion about the nucleus. The orbit is, in fact, a small loop of current and has a magnetic field that's associated with a current loop. In addition, experimental and theoretical investigation seems to indicate that the electron itself has a spin. Each electron, having its own axis, is a spinning sphere of electric charge. *Electron spin*, like the quantum and wave theories of light, is not so much a literal interpretation of a phenomenon as a useful concept that holds water when applied to the phenomenon of magnetism.

When the electron spins, the charge that is in motion produces a magnetic field. And, to briefly state the electronic explanation of magnetism, it seems that the magnetic properties of matter can be attributed to the orbital and spinning motion of the electrons comprising the atoms of the matter.

Millennia of Magnetism. Some of the basic principles and effects of magnetism have been known for centuries. The Greeks are credited as the ones who first discovered magnetism. They noted that a certain type of rock had the ability of attracting iron. Later, the Chinese noted that an elongated piece of this rock had the useful property of always pointing in a north-south direction when suspended by a string. This was the beginning of our compass.

This strange stone which intrigued people over the centuries is actually a form of iron ore known as magnetite. Not all magnetite shows magnetic properties. Another name for the magnetic variety of magnetite is lodestone—the term lodestone being derived from two separate words, lode and stone. The term "lode" stands for guide, hence lodestone means "guide stone."

All magnets, whether natural or manmade, possess magnetic poles, which are commonly known as the magnet's north and south pole. As is the case of the electrical charges (which we studied earlier) between unlike magnetic poles and repulsion between like poles, it has been found that this magnetic attraction and repulsion force varies inversely as the square of the distance from the magnetic poles.

The Magnetic Field. We all know how a magnet exerts a force of attraction on a piece of magnetic material such as iron or steel. Also, when the north poles of two magnets are brought close together, they will try to repel each other, while there will be attraction between the north and south poles of two magnets. Although it is not clearly understood just what this force of magnetic attraction and repulsion is, it is convenient to visualize magnetic lines of force which extend outward from one magnetic pole to the other as illustrated in Fig. 19.

Permeability. Magnetic lines of force can pass through various materials with varying ease. Iron and steel, for example, offer little resistance to magnetic lines of force. It is because of this that these materials are so readily attracted by magnets. On the other hand, materials such as wood, aluminum and brass do not concentrate or encourage the passage of magnetic lines of force, and as a consequence are not attracted by magnets.

The amount of attraction a material offers to magnetic lines of force is known as its permeability. Iron and steel, for example, possess high permeability since they offer little resistance to magnetic lines of force. Nonmagnetic materials have low permeability. For practical purposes, we can say that reluctance is to magnetic lines of force what resistance is to an electrical current.

Electromagnetism. Any electrical conductor through which flows an electrical current will generate a magnetic field about it which is perpendicular to its axis as shown in Fig. 20. The direction of this field is dependent upon the direction of current flow, and the magnetic field strength proportional to the current strength. If this current-carrying conductor is wound into a coil, forming a solenoid, the magnetic field will be increased by each individual turn that is added. If an iron core is inserted in this current-carrying coil, the generated field will be increased still further. This is because the lines of force are concentrated within the iron core which has considerably less reluctance than the surrounding air.

The magnetic power of a multi-turn current-carrying coil through which a core is inserted is proportional to the current flowing through the coil as well as the number of turns in the coil. The current through the coil is termed *ampere turns*. As an example, if a coil consisting of 200

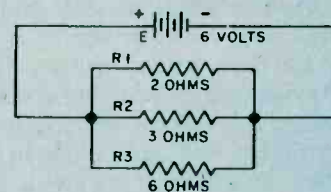

Fig. 17. Ohm's law can be used to determine the equivalent resistance of two or more resistors in parallel. Total current—then solve for ohms.

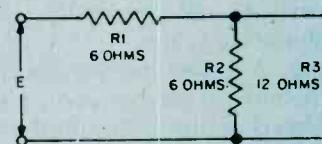

Fig. 18. Series-parallel circuit is not really difficult. Add R2 and R3 algebraically. Add effective resistance to R1 for total resistance.

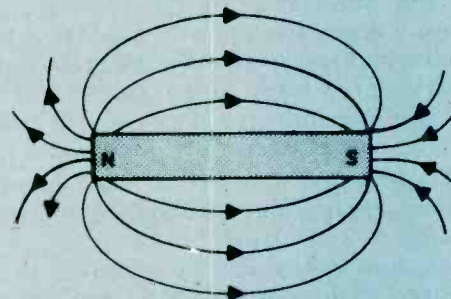

Fig. 19. Lines of force around bar magnet can be made visible by sprinkling iron filings onto white paper over magnet. Lightly tap the paper and all the filings will line up with the lines of force.

turns is carrying 2 amperes, its ampere turns equal:

$$\begin{aligned} \text{Ampere turns} &= 200 \text{ turns} \times 2 \text{ amps.} \\ \text{Ampere turns} &= 400 \text{ ampere turns} \end{aligned}$$

Similarly a coil of 100 turns through which a current of four amperes flows also has 400 ampere turns.

Electromagnetic Induction. We saw earlier how a current-carrying conductor will generate a magnetic field which is perpendicular to the conductor's axis. Conversely, a current will be induced in a conductor when the conductor is passed through a magnetic field. The strength of this induced current is proportional to both the speed at which it passes through the field and the strength of the field. One of the basic laws pertaining to electromagnetic induction is Lenz's law which states: "The magnetic action of an induced current is of such a direction as to resist the motion by which it is produced."

Fig. 21 illustrates two coils, A and B, which are placed in close proximity to each other. Coil A is connected in series with a switch and battery so that a current may be sent through it when the switch is closed, and coil B is connected with a current-indicating DC meter. When the switch is closed, current will flow through coil A, causing a magnetic field to be built up around it. In the brief instant that the field is building up to maximum, it will "cut" the turns of coil B, inducing a current in it, as indicated by a momentary flick of the indicating meter. When the switch is opened, breaking the current flow through coil A, the field around coil A will collapse, and in so doing will again induce a current in coil B. This time, however, the flow of current will be in the opposite direction. The meter will now flick in the direction opposite to when the switch was closed. The important thing to remember is that the conductor must be in motion with respect to the magnetic field or vice versa in order to induce a current flow. You can perform this simple experiment using two coils made of bell wire wrapped around large nails, a few dry cells in series, and a DC zero-center scale meter.

Self Induction. As mentioned a short while ago, a magnetic field is built up around a coil at the application of current through the coil. As this field is building up, its moving lines of flux will cut the turns of the coil inducing a counter-electromotive force or counter-EMF which opposes the current flowing into the coil.

The amount of counter-EMF generated depends upon the rate of change in amplitude of the applied current as well as the inductance of the coil. This value of inductance is dependent upon the number of turns in the coil; a coil with many turns will have greater inductance than a coil with few turns. Also, if an iron core is inserted into the coil, the inductance of the coil will increase sharply. The unit of inductance is known as the *Henry*.

The Transformer. One of the most important and widely used applications of magnetic induction is the transformer.

Fig. 22 shows the basic construction of a typical transformer. While two separate windings are shown here, some transformers can have as many as five or six windings.

A transformer consists of two or more separate windings, electrically insulated from each other. One

winding, known as the primary winding, is fed from a source of alternating current.

The alternating currents flowing through the primary induce a current in the secondary winding by virtue of magnetic induction. The transformer core is constructed from a relatively high permeability material such as iron which readily conducts magnetic flux between the primary winding and the secondary winding.

The alternating current flowing in the primary of the transformer produces a variation in the magnetic flux circulation in the transformer core which tends to oppose the current flowing in the primary winding by virtue of self-induction. The counter-EMF is just about equal to the voltage applied to the primary winding when no load is connected to the transformer's secondary winding.

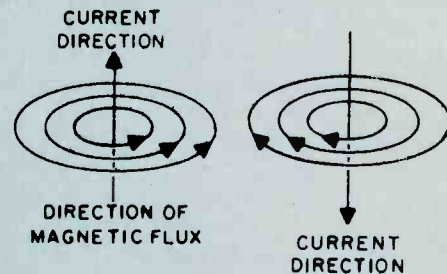

Fig. 20. Direction of flux lines is changed by direction of the current. Heavy current is needed to make flux lines visible with sprinkled filings.

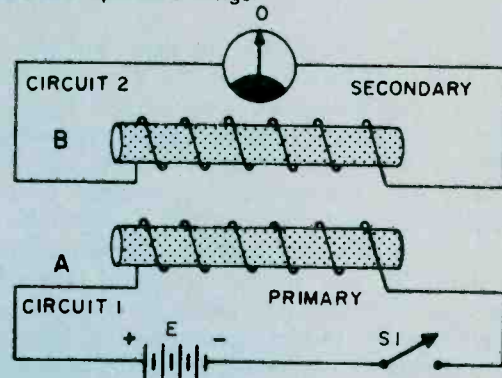

Fig. 21. Two-core transformer is inefficient since an air gap at either end does not have permeability of a ferrous metal and some flux lines do not go through core of secondary winding (B)—their effect is lost.

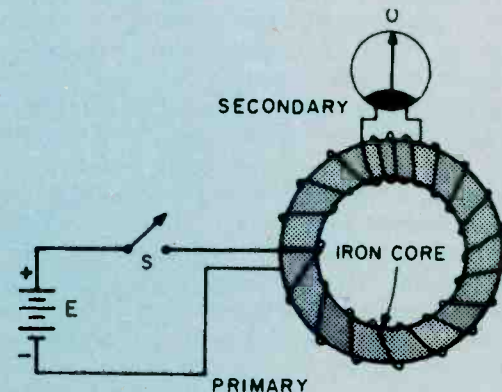

Fig. 22. Toroidal core is highly efficient but is very difficult to manufacture. Familiar C- and E-shape core has less waste and windings are slipped over the core. Efficiency is good—about 90 percent for most designs.

This accounts for the fact that very little current flows through the primary winding when no load is connected to the secondary. The negligible current that does flow under this no-load condition is known as the transformer magnetizing current. As the current drawn from the secondary winding increases, the primary current will increase proportionately due to the reduction in the counter-EMF developed in the primary winding of the transformer.

In any transformer the ratio of the primary to secondary voltage is equal to the ratio of the number of turns in the primary and secondary windings. This is expressed mathematically as follows:

$$\frac{E_p}{E_s} = \frac{N_p}{N_s}$$

where E_p = primary supply voltage
 E_s = voltage developed across secondary
 N_p = number of primary turns
 N_s = number of secondary turns

The above formula assumes that there are no losses in the transformer. Actually, all transformers possess some losses which must be taken into account.

Transformer Losses. No transformer can be 100 percent efficient due to losses in the magnetic flux coupling the primary and secondary windings, eddy current losses in the transformer core, and copper losses due to the resistance of the windings.

Loss of magnetic flux leakage occurs when *not all* the flux generated by current flowing in the primary reaches the secondary winding. The proper choice of core material and physical core design can reduce flux

leakage to a negligible value.

Practical transformers have a certain amount of power loss which is due to power being absorbed in the resistance of the primary and secondary windings. This power loss, known as the copper loss, appears as heating of the primary and secondary windings.

There are several forms of core loss—hysteresis and eddy current losses. Hysteresis losses are the result of the energy required to continually realign the magnetic domain of the core material. Eddy current loss results from circulating currents induced in the transformer core by current flowing in the primary winding. These eddy currents cause heating of the core.

Eddy current loss can be greatly reduced by forming the core from a stack of individual sheets, known as laminations, rather than from a single solid piece of steel. Since eddy current losses are proportional to the square of core thickness, it is easy to see that the individual thin laminations will have much less eddy current loss as compared with a single thick core.

Another factor which effects eddy current loss is the operating frequency for which the transformer is designed to operate. As the operating frequency is increased, the eddy current losses increase. It is for this reason that transformers designed to operate at radio frequencies often have air cores and are void of ferrous metals.

Theory and Practice. We've come a long way from our initial discussion of the atom and its importance for an understanding of electricity and magnetism. And there's still a long way to travel to understand all about the subatomic nucleus and its satellites and how they are being harnessed in an ever-expanding electronics technology. But, we move ahead by mixing theory with practice—so, put your new knowledge to work in a project or two! ■

ELECTRONICS LANGUAGE

Anyone who has built a small project or read a beginning article on electronic theory is certain to have run across such terms as *microFarad*, *milliHenry*, and *milliAmpere*—not to mention *megaHertz*, *megOhm*, and *kiloHertz*. The prefixes here, *micro-*, *milli-*, *mega-*, and *kilo-*, are an important part of the electronic vocabulary. It follows, then that anyone who wants to be proficient in electronics will have to develop skill in understanding and using the "language."

These prefixes are used to change the value of an electronic unit of measure. For example, if you see a resistor with the familiar brown/black/green color code, you *could* call it a 1,000,000-ohm resistor. The thing is, it's usually less awkward to call it a 1-megohm resistor. Purring the prefix *meg-* or *mega-* before the Ohm inflates the value of the unit, Ohm, by 1,000,000 times.

Similarly, one kiloVolt is recognizable as 1,000 Volts, and one kiloHertz as 1,000 Hertz, and so on. These prefixes are usually so automatic with electronics aficionados that they will invariably refer to a millionaire

as a guy who has one megabuck!

The Mini Side. At the other end of the scale, the *milli-* and *micro-* prefixes are useful for shrinking units. A Farad, for example, is too big a unit to use in everyday electronics. In dealing with the real-life capacitors (the kind you solder into circuits), we normally use a basic unit of *one-millionth* of a Farad—a *microFarad*. The prefix *micro-* cuts up a unit into a million tiny slices, enabling us to use one such slice as a convenient-sized unit. A microAmpere, similarly, is a millionth of an Ampere; a microVolt, one millionth of a Volt.

If you need larger slices, the *milli-* prefix is available, which provides a unit only one-thousandth the size of the basic unit. A milliAmpere, for example, is a thousandth of an Ampere; that is, it takes 1000 mA (milliAmperes) to equal 1 Ampere.

To handle these tiny slices of units, it's wise to spend a few minutes learning *scientific notation*, which is designed to make it easy to handle very large and very small numbers. Once you've mastered this technique,

you can manipulate all the various-sized units of electronics as easily as you can add two and two!

The Maxi Side. Take, for example, the familiar *kiloHertz* (known at one time as the *kilocycle*). A broadcasting station operating at 840 kHz (kiloHertz) in the broadcasting band is radiating 840,000 cycles of RF energy every second. To change from 840 kHz to 840,000 Hz, you can think of the "kilo-" as being replaced by "x 1000", thus:

840	kilo	Hertz
840	× 1000	Hertz
840,000		Hertz

But you can also write "1000" as "10 x 10 x 10". And you can write "10 x 10 x 10" as "10³". (Ten to the third power, or ten cubed.) As we develop these ideas further, you will see how you can greatly simplify your future work in electronics by thinking of the prefix "kilo-" as being replaceable by "x 10³", thus:

$$840 \text{ kiloHertz} = 840 \times 10^3 \text{ Hertz}$$

Similarly, a 6.8-megohm resistor, measured on an ohmmeter, will indicate 6,800,000 ohms. In this case, the prefix "meg-" can be replaced by "x 1,000,000":

6.8	meg	Ohms
6.8	× 1,000,000	Ohms
6,800,000		Ohms

But you can write "1,000,000" as "10 x 10 x 10 x 10 x 10 x 10" (six of them; count 'em), which is 10⁶. Thus, you should learn to mentally replace "meg-" with x 10⁶, so that 6.8 megOhms becomes a 6.8 x 10⁶ Ohms. The 6 is called an *exponent*, and shows how many 10s are multiplied together.

The Minus Crowd. What about the "milli-" and "micro-" prefixes? "Milli-", we've said, is one-thousandth; in a way it is the opposite of the "kilo-" prefix. Make a mental note, then, that milli- can be replaced with "10⁻³" (read as "ten to the minus three power"), which is 1/10 x 1/10 x 1/10 = 1/1000. Similarly, the "micro-" prefix can be considered as the opposite of "meg-", and replaced by 10⁻⁶.

The beauty of this approach appears when you are faced with a practical problem, such as, "if 1.2 milliAmperes flows through 3.3 megOhms, what voltage appears across the resistor?" From our knowledge of Ohm's law, we know that E = IR; that is, to get Volts (E) we multiply current (I) times resistance (R). Without the aid of scientific notation, the problem is to multiply 0.0012 Amperes by 3,300,000 Ohms, which is rather awkward to carry out. The same problem, however, is very easy in scientific notation, as can be seen below:

$$\begin{aligned} E &= (1.2 \times 10^{-3}) \times (3.3 \times 10^6) \\ E &= 3.96 \times 10^3 \text{ Volts} \\ E &= 3.96 \text{ kiloVolts} = 3960 \text{ Volts} \end{aligned}$$

The answer is 3.96 x 10³ Volts, or 3.96 kiloVolts. We obtained the answer by multiplying 1.2 x 3.3 to get 3.96, and adding the -3 exponent to the 6 exponent to get 3 for the exponent of the answer. The advantage of scientific

notation is that the largeness and smallness of the numbers involved is indicated by numbers like 10⁶ and 10⁻³, and the largeness or smallness of the answer is found by *adding* the 6 and the -3.

What about a division problem? For the sake of a good illustrative example, consider the unlikely problem of finding the current when 4.8 megaVolts is applied across 2 kilOhms. The problem is written as:

$$\begin{aligned} I &= \frac{E}{R} \\ &= \frac{4.8 \text{ megaVolts}}{2 \text{ kilOhms}} = \frac{4.8 \times 10^6 \text{ Volts}}{2.0 \times 10^3 \text{ Ohms}} \\ &4.8 \div 2 = 2.4, \end{aligned}$$

where 2.4 x 10³ Amperes = kiloAmperes.

In division, then finding the size of the answer becomes a *subtraction* problem, in which the exponent representing the size of the divisor ("bottom" number) is subtracted from the exponent representing the size of the dividend ("top" number).

A more practical division problem answers the question, "What current flows when 5 Volts is applied across 2.5 kilOhms?"

$$\begin{aligned} I &= \frac{E}{R} = \frac{5 \text{ Volts}}{2.5 \text{ kilOhms}} \\ &= \frac{5.0 \times 10^0}{2.5 \times 10^3} = \frac{5.0 \times 10^{-3}}{2.5} \\ &= 2.0 \times 10^{-3} \text{ Amperes} \\ &= 2.0 \text{ miliAmperes} \end{aligned}$$

Note that it's perfectly legal to use 10⁰ (ten to the zero power) to indicate a unit that has no prefix—in other words, one of anything.

For the Solving. Here are a few more problems:

1. The inductive reactance of a coil is given by

$$X_L = 2\pi fL$$

What is the reactance of a coil whose inductance L = 22 milliHenries, when an alternating current of frequency f = 1.5 megaHertz is applied to it?

$$\begin{aligned} X_L &= 2 \times \pi \times (1.5 \times 10^6) \times (22 \times 10^{-3}) \\ &= 207.24 \times 10^3 \text{ Ohms} \\ &= 207.24 \text{ kilOhms} \end{aligned}$$

2. An oscillator is connected to a wavelength-measuring apparatus, and the wavelength of its oscillations is determined to be 2.1 meters. What is the frequency of the oscillator?

$$F = \frac{\text{speed of light}}{\text{wavelength}}$$

$$F = \frac{3.0 \times 10^8 \text{ meters per second}}{\text{wavelength}}$$

$$F = \frac{3.0 \times 10^8}{2.1 \times 10^0} = 1.4286 \times 10^8 \text{ Hertz}$$

We wish this answer had come out with a "10⁶", instead of a "10⁸", because we can convert 10⁸ Hertz directly to megaHertz. However, we can change the answer to 10⁶, by shifting the decimal point of the 1.4286. Remember this rule: To *lower* the exponent, shift the decimal point to the *right*. (Of course, the opposite rule is also true.) Since we wish to lower the exponent by 2, we must shift the decimal point to the right by two places:

$$1442.86 \times 10^6 \text{ Hertz} = 142.86 \text{ megaHertz}$$

3. A 3.3 microfarad capacitor is being charged from a 20-volt battery through a 6.8-kilOhm resistor. It charges to half the battery voltage in a time given by

$$T = 0.69RC$$

For the particular values given in the problem, what is the time taken to charge to half the battery voltage?

$$T = 0.69 \times (6.8 \times 10^3) \times (3.3 \times 10^6) \\ 15.4 \text{ milliseconds}$$

4. A 365-pF variable capacitor and a 2-μH coil are found collecting dust in your junk box. You decide you might like to incorporate them into a radio but you need to know the resonant frequency of this inductive/capacitive circuit. You apply the formula:

$$f = \frac{1}{2\pi LC}$$

Since C = 365-pF or 365 × 10⁻¹² Farads and L = 2-μH or 2 × 10⁻⁶ Henrys we can use these numbers, the formula and

our new knowledge of exponents to determine the frequency.

$$f = \frac{1}{2\pi (2 \times 10^{-6}) \times (365 \times 10^{-12})}$$

$$= 5,894,627.6 \text{ Hertz} \\ = 5,895 \text{ kiloHertz} \\ = 5.895 \text{ megaHertz}$$

Tera to Atto. Since scientific notation is so potent, you'll probably be interested in the meaning of *all* the prefixes used in the scientific community, not just the four (micro-milli-, kilo-, and mega-)—that we've discussed so far. Very common in electronics is the *micro-microFarad*, which is 10⁻⁶ × 10⁻⁶ Farad, or 10⁻¹² Farad. This is more commonly known as the *picoFarad*. Similarly, a thousandth of a microAmpere is 10⁻³ × 10⁻⁶ Ampere, or 10⁻⁹ Ampere. This is known as a nanoAmpere. At the other extreme, 1000 megaHertz is called a gigaHertz. See the Table of electronic prefixes and their meanings for all these prefixes, and, for a rundown of their meanings and pronunciations.

The jargon of electronics which has grown up around their prefixes is just as important as the prefixes themselves. Here are some examples of "jargonized" prefixes as they might appear in speech:

Puff—a picoFarad (from the abbreviation, PF).

Mickey-mike—a micro-microFarad (which is the same as a puff).

Meg—a megohm. Also, less often, a megaHertz.

Mill—a milliAmpere.

Megger—a device for measuring megohms.

dB (pronounced "dee-bee")—a deciBel, which is one-tenth of a Bel.

Mike—a microFarad. Also, to measure with a micrometer.

So, if you understand the prefixes and know their corresponding exponents, you'll have command of another set of important tools to help you do practical work in electronics. In addition, you'll be ready for the inevitable wise guy who'll ask if you can tell him the reactance of a 100-puff capacitor at 200 gigaHertz. After calculating the answer in gigaseconds, reply in femt-Ohms!

HOW FLOPPY DISK SYSTEMS WORK

Sooner or later just about every serious computer hobbyist reaches their computer's memory limit. There are some applications that require too much I/O action to be practical with a cassette based system or require too much memory space to fit in a RAM. It's this need for high-volume storage and rapid access time that makes a hobbyist disk system desirable. These systems don't come close to commercial hard disk systems in terms of

performance but they can easily fill the computer hobbyist's memory bill.

Floppies have become the missing link to a midrange of random access memory systems. The floppy offers higher performance at lower cost than cassette and similar types of Input/Output (I/O) devices.

Well Packaged. The present standard floppy is an 8-inch flexible disk of a plastic material coated with a

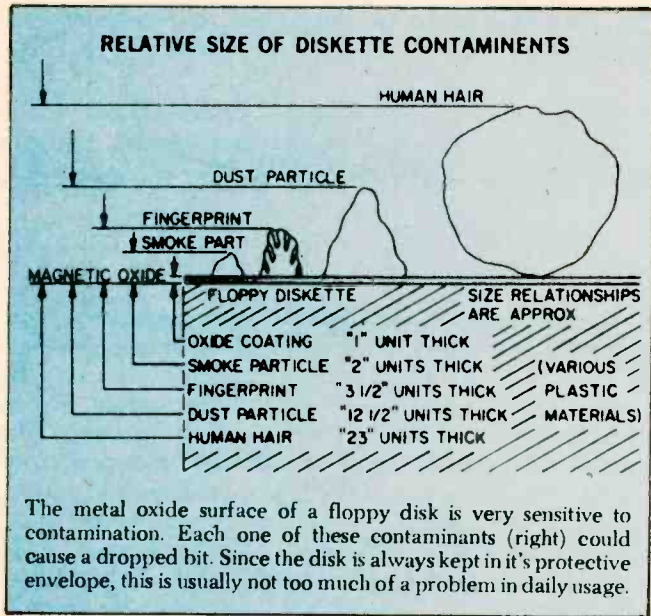

magnetic oxide. Looking a little like a popular 45 RPM record, it is sealed inside a jacket and there are no grooves on the surface.

The disk cannot be removed from the jacket which is designed to protect the recording surface. The disk is visible at a slot, a spot, and a hole in the center of the jacket. Users are told by the instructions that we must not touch exposed areas of the disk or write on it with anything firmer than a Q tip. Finally the user is admonished to return the jacketed disk to its outer envelope after they have finished using it.

The natural skin oil of fingerprints can damage the quality of music in needle and groove recordings, and in the super-miniature world of floppies, a fingerprint can destroy an entire segment of data. A dust particle can waste a dozen sectors and a human hair can reduce the effectiveness of the *Read/Write/Erase (R/W/E)* heads.

It is understandable why the media, as the flexible disk is sometimes called, is permanently sealed with all of those implicit instructions. There is, however, an internal jacket wiper that continually cleans the rotating disk and removes contaminants, and floppies are reasonably rugged.

Hardware. The disk-drive hardware is add-on equipment to the main frame of the computer. Inside the drive are motors, driving mechanisms, and interfacing electronics that enable the drive unit to "talk" with the controller.

The diskette is inserted into the drive unit through a small door in the front. Once the door is shut, it is locked by the drive unit logic until the door release button is pushed to disable the drive assembly. The drive spindle centers and grasps the center of the diskette firmly as the motor comes up to speed. During power-up the diskette reaches a speed of 360 RPM, and *R/W/E* heads are stepped out to track 00 and a mechanical index hole provides the first location pulse for disk timing. In the IBM format this is the only reference to a physical location on the disk.

The floppy is firmly held against the recording surface, and the heads are positioned by a precise stepping motor. While the heads are positioned over the

desired track, they ride above the spinning diskette. Once the correct track is located, in what is called a "seek operation," a head loading coil pulls the heads down onto the magnetic surface. This operation is called loading the heads and it is controlled by a computer program.

When the heads are to be moved again, in another seek operation, to a new track, they are first unloaded, stepped to a new track, and then reloaded to a new track. This requires about three milliseconds per track of movement. It will further require about 50 milliseconds, per track, to move the heads and about 15 milliseconds of settling time.

Part of System. Floppies should always be thought of as a part of a sophisticated cluster of mechanical drivers, computer electronics, and software called a computer. Fundamentally this computer consists of a central processor unit (CPU), some memory, some interfacing devices, called controllers here, and an entry device such as a keyboard CRT, and some software.

Computer operation is made possible by a written program entered into the computer's memory and operated on by the internal microprocessor. The programs are fed by any one of a number of techniques: a paper tape punch, keyboard, cassette tape, or teletype. All of these are slow and time consuming. New ways are continually being introduced to feed the voracious appetite of computer memories. Floppies are the most

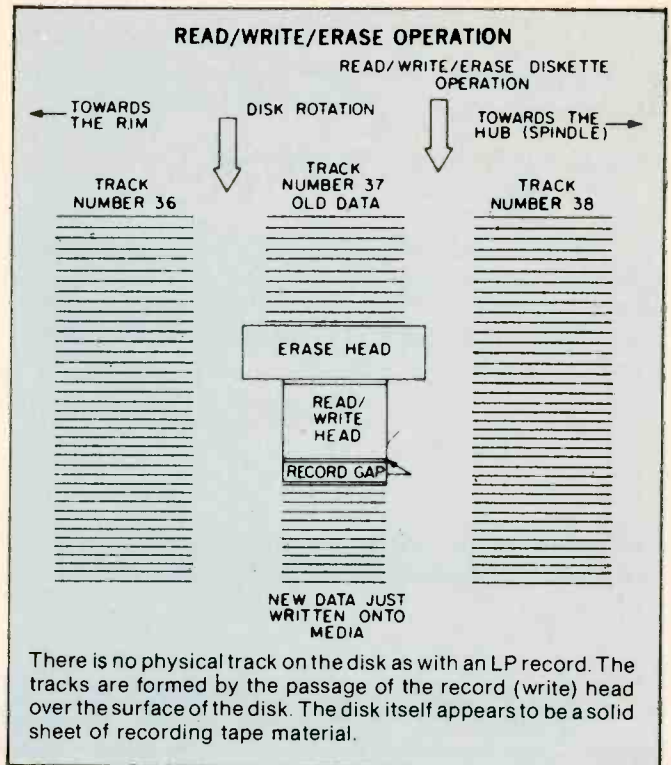

versatile of the program instruction loading techniques.

In a computer's time frame things go on a million times faster than in our brain's time frame. In such a whirlwind existence, telling computers what to do was a difficult problem. The answer was in the development of software which the computer could store in memory for reference each time it needed a new program instruction.

Software. The computer—the IC's, printed circuit boards, filter capacitors, chassis, and power supply—are

WITH CIE, THE WORLD OF ELECTRONICS CAN BE YOUR WORLD, TOO.

Look at the world as it was 20 years ago and as it is today. Now, try to name another field that's grown faster in those 20 years than electronics. Everywhere you look, you'll find electronics in action. In industry, aerospace, business, medicine, science, government, communications—you name it. And as high technology grows, electronics will grow. Which means few other fields, if any, offer more career opportunities, more job security, more room for advancement—if you have the right skills.

SPECIALISTS NEED SPECIALIZED TRAINING.

It stands to reason that you learn anything best from a specialist, and CIE is the largest independent home study school specializing exclusively in electronics, with a record that speaks for itself. According to a recent survey, 92% of CIE graduates are employed in electronics or a closely related field. When you're investing your time and money, you deserve results like that.

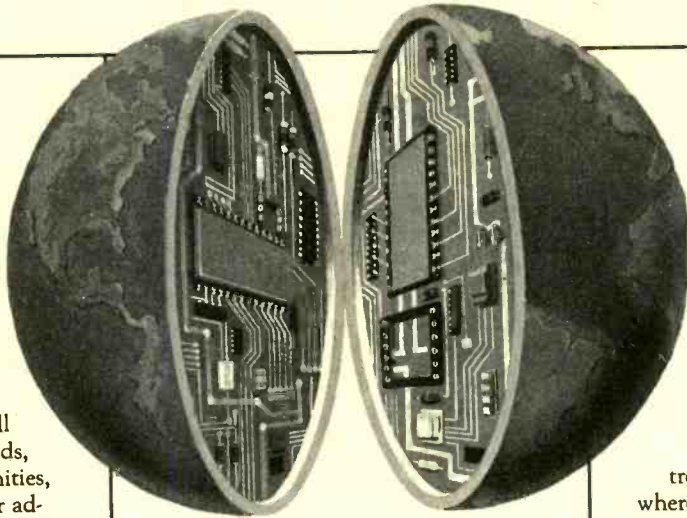

INDEPENDENT STUDY BACKED BY PERSONAL ATTENTION.

We believe in independent study because it puts you in a classroom of one. So you can study where and when you want. At your pace, not somebody else's. And with over 50 years of experience, we've developed proven programs to give you the support such study demands. Programs that give you the theory you need backed with practical experience using some of the most sophisticated electronics tools available anywhere, including our Microprocessor Training Laboratory with 4K of random access memory. Of course, if you ever have a question or problem, our instructors are only a phone call away.

START WHERE YOU WANT, GO AS FAR AS YOU WANT.

CIE's broad range of entry, intermediate, and advanced level courses in a variety of career areas gives you many options. Start with the Career Course that best suits your talents and interests and go as far as you want—all the way, if you wish, to your Associate in Applied Science Degree in Electronics Engineering Technology. But wherever you start, the time to start is now. Simply use the coupon below to send for your FREE CIE catalog and complete package of career information. Or phone us at 1-800-321-2155 (in Ohio, 1-800-362-2105). Don't wait, ask for your free catalog now. After all, there's a whole world of electronics out there waiting for you.

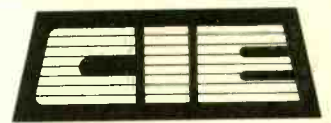

Cleveland Institute of Electronics, Inc.

1776 East 17th Street
Cleveland, Ohio 44114
216-781-9400

A half century teaching electronics.



Cleveland Institute of Electronics, Inc.

1776 East 17th Street, Cleveland, Ohio 44114

YES...I want to learn from the specialists in electronics—CIE. Please send me my FREE CIE school catalog, including details about CIE's Associate Degree program, plus my FREE package of home study information.

Print Name _____

Address _____

City _____ State _____ Zip _____

Age _____ Area Code/Phone No. _____ / _____

Check box for G.I. Bill bulletin on educational benefits: Veteran Active Duty

MAIL TODAY!

all part of the hardware. All of this state-of-the-art electronics is just so much junk without a program, a way to make the computer compute. The instructions, written in computer languages, are called software.

We talk with the floppy (human to floppy) through a series of interpreters comprised of software and hardware. First we place our instructions, using perhaps, Fortran in a machine assembly language. Located within this language and acting as a general interpreter, is a section of software called a file manager. Its job is to take general instructions, count words to be put on the floppy, calculate the number of sectors, tracks and floppies that will be needed to store your file. All we do is to tell the file manager how much and where; it will do the rest. It will even put the data on the floppy then check to see if it got there, and if not correct its own errors. The special language of the computer is based on the numbers zero and one.

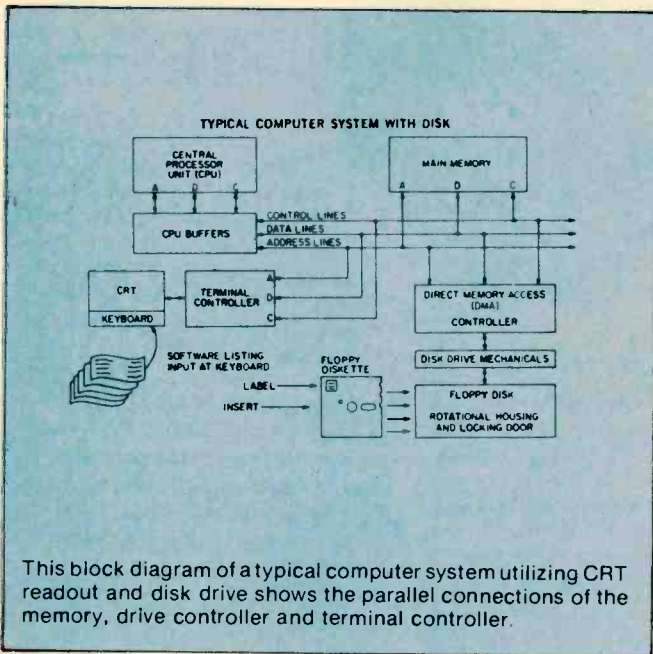

These two values comprise one "bit" of information. At this level there are no grey areas, no informational maybes. Facts are either a zero or they are a one. In this language a word has only one length of the micro-computer. It is 16-bits long. That is 16-bits having two states or thirty two pieces of information. However most peripheral devices, such as the floppy controller, that hunk of electronics that interfaces (talks) between the floppy and the CPU, is designed to speak in half words. This half word is called *Byte*, pronounced "bite." A byte has 8-bits so there are two bytes to a full 16-bit word computer.

The story doesn't stop here. A new term is emerging in the industry as they learn to manipulate the byte. It is the half byte and is called a nibble.

Disk Mechanics. The R/W/E slot in the floppy jacket is two inches long by 1/2-inch wide. That little hole on the opposite side (8 inch diskette) is the mechanical index hole, which is a physical starting place (read by a LED sensor) for recording information on the oxide surface.

On a tape cassette you can break off a plastic tab thereby preventing further over recording on that

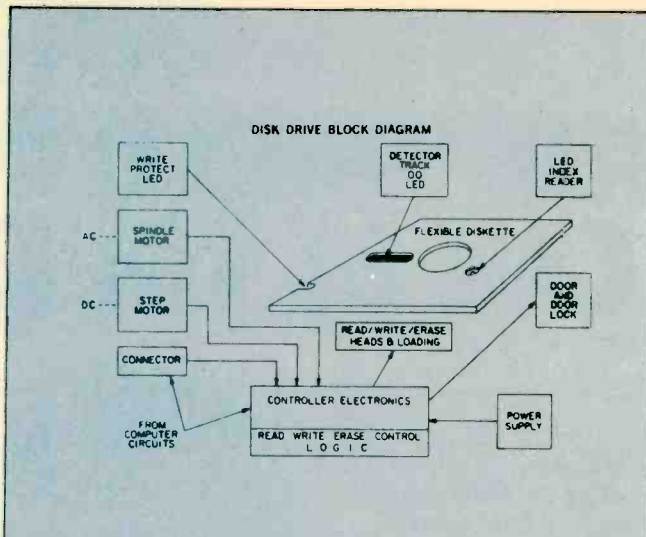

You can easily see from this diagram how the physical configuration of the disk is related to the various electronic systems needed to control information storage and retrieval.

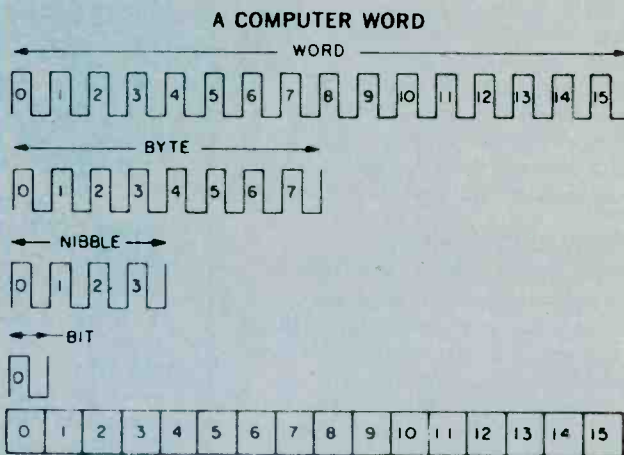

Software is the artful manipulation of the WORDS, bytes, nibbles, and bits utilized in transferring something meaningful between humans and machines without resulting in the total disorientation of the two parties involved.

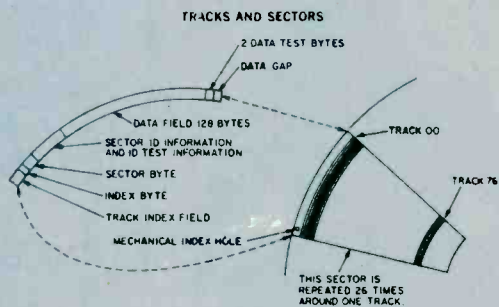

This diagram shows the relationship between track information and sector information as they are physically located upon the disk when utilizing the IBM-type disk formatting.

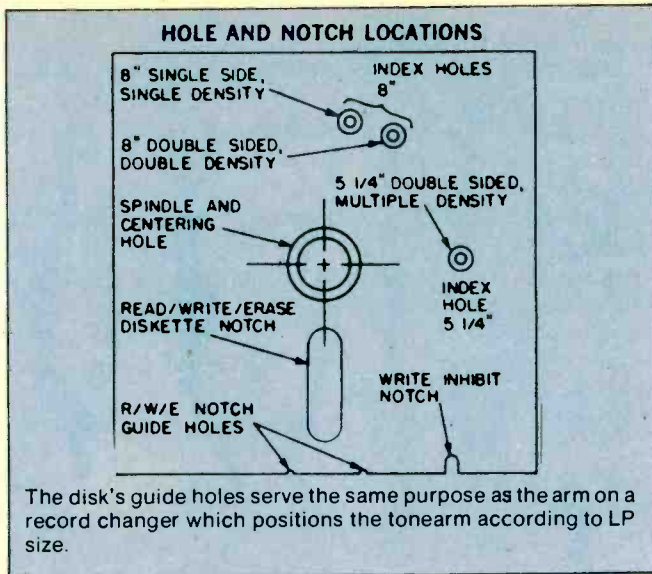

cassette. An industry term for this is 'record protect.' Floppy disk jackets have this same feature, in a slightly different form. On some jackets there is a write protect slot cut in the paper of the jacket. When not needed the slot is covered over. This slot permits a photo-optical system to shut off the *write* electronics when the system detects a slot. In this way valuable programs already recorded are not destroyed by writing over the program. With some drive units there is a switch to override this system, with other drives we must tape over the write protect slot.

The erase head most widely used may be either a tunnel-erase or a straddle-erase head. The tunnel-erase head design minimizes the influence of noise from data in adjacent tracks. This more clearly defines the erase band and improves the signal to noise ratio. Present usage seems to favor the tunnel-erase head design.

To place information on the diskette (to *write*) and to retrieve information (to *read*) a software plan called a *format* is employed to pre-organize diskette data fields. Where only a single reference is made to the mechanical index the resulting formatting is called soft sectoring. Most of the information presented here is for a single density, soft-sectored, IBM formatted diskette. After receiving the pulse that represents the index hole, the rest of the floppy is formatted from the software, or computer program.

IBM Format. The IBM 3470 formatted diskette, one of the more popular industry standards, has 77 tracks, with 26 sectors, (data spaces) formatted per track. There are 128 bytes per sector, 256 nibbles, or 1024 bits. The total numbers of sectors per single density diskette is 2002. Of the tracks, 74 are for data storage, two are set aside as alternate "bad tracks reserves," and another track is reserved for maintenance purposed. A typical data transfer rate from floppy to controller is 250 kilobytes per second.

The tracks are numbered from the outside in with number 00 on the rim. Number 76 is the last track and is nearest the hub. Remember that there are no real tracks that you can see. They are the products of a software format, in this case IBM format 3470. These single sided, FM coded (more about that in a moment) disks can have

a recording density of 3408 bits per inch.

A second type of sectoring is called hard-sectoring. Thirty two holes are cut in the diskette. These become the index marks for each sector. There is a 23% increase in data packing in hard-sectoring but the industry seems to prefer the soft-sectored format.

The sectors each contain a data field, with data gaps to guard this information, sector and track identification, again with gaps to protect this information, and guard bytes to further isolate sectors of information. All activity is in byte-length half-word groups.

Frequency Mod. The technique used to place data on the diskette is called Frequency Modulation (FM). Clock Pulses, 4 micro-seconds apart, from a 250-KHz clock generator, are placed on the floppy sectors forming data cells. This is the time from one clock pulse to the next. A magnetic transition within a data cell is read from the data stream as a one; no transition as a zero. The data bit will fall into the center of a 4 microsecond data cell.

When the controller performs a read operation, the data stream going back to the drive electronics and on to the controller where the data is separated from the clock pulses, a known frequency, and also the index mark, sector data, and addressing information is removed before sending the data on to the Central processing unit.

As you might imagine there are sometimes errors in either a read or a write operation. A software test program is designed to search out these errors. They will be classed as either hard or soft errors. That is an error traceable to a piece of hardware such as a faulty motor is a hard error. An error traceable to a poorly formatted sector will be a soft error. One possible soft error would be a bad sector such that data could not be written into the sector. The controller would store the address of that sector in a *Bad-Sector* file in memory and search out another sector. Later if the computer addressed that bad-sector, the file manager would discover that it was bad and immediately go to the address of the new sector used in place of the damaged one. At some future date the user might want to replace the floppy if there are too many bad sectors.

As the industry gets better at the techniques to pack and crunch data onto a small recording surface, floppy usage will increase. Shugart and Perneck, among others, are offering the double density floppy employing a recording code permitting double data packing using the MFM or Modified Frequency Modulation code. Two

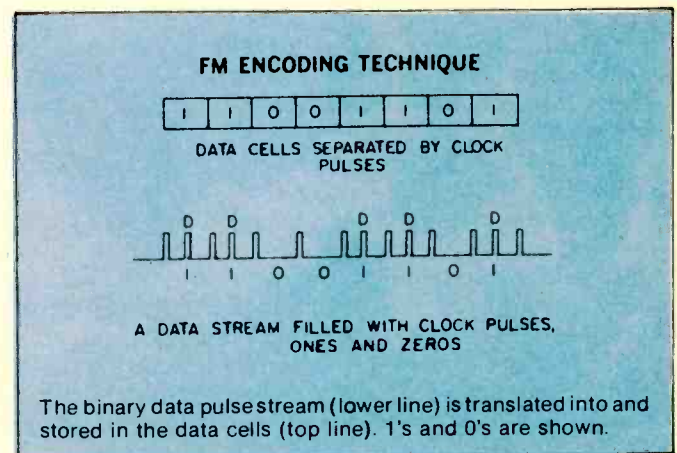

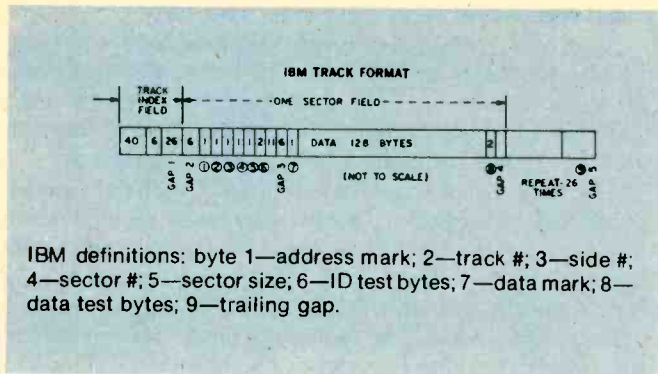

other codes now in use are the Modified MFM or the Group Code Recording (GCR) technique. Double sided recording heads have also been introduced allowing recording on both sides of the floppy with transfer rates

of 500 Kilobytes per second and 256 bytes per disk sector.

Mini-Floppy. Hardly had this double density, double sided floppy been introduced when the mini-floppy popped on the stage. Only 5¼ inches in diameter, it uses a coding scheme called the Modified MFM, with the index hole shifted 90 degrees to the right. The Radio Shack add-on TRS Mini-Disk System, uses a mini floppy. Cost is about \$500 for the "first Disk-Drive." As with all disk systems, a certain number of sectors are devoted to housekeeping, sometimes called labeling. Those sectors usually consists of a directory, test programs, and other sector and track information so that it will talk smoothly with its computer system.

The flexible diskette is a very useful peripheral device used with a I/O controller and can be used to store special diagnostics (hardware test programs) and debugging routines. ■

SYNTHESIZER SCIENCE

There is no doubt that electronic synthesizers have made a major impact on the world of music, and are here to stay. No longer are they limited to experimental avant-garde works. There are dozens of albums of traditional music (both classical and popular) played on synthesizers, and they are widely used in radio and television commercials, and popular music of all kinds; rock, jazz, and even western.

A good synthesizer can take the place of literally dozens of other instruments, and can easily produce sounds that would be difficult, if not impossible, to duplicate on acoustic instruments. Synthesizers are fascinating to experiment and practice with.

Many people, however, are reluctant to try them, fearing they are too complex for the beginner.

Actually, synthesizers can be quite easy to understand, if you just take them one step at a time. Synthesizers are really nothing more than packages of modules, that can be connected in various ways to produce different sounds. Once you understand the basics it's not hard to design an experimental synthesizer of your own.

Basically, there are four types of modules in synthesizers; oscillators, which produce the basic signal; filters, which modify the harmonic content, or tone of the signal; amplifiers, which modify the dynamics or volume of the signal; and, finally, some method of controlling all the modules.

You could use potentiometers to control all these devices manually (in fact, that is what the early electronic music composers did). That method is very awkward and tedious. Most modern synthesizers use some form of voltage control in their electronic circuit.

The voltage to a voltage-controlled oscillator (VCO) would control the frequency of the signal, or the pitch. The voltage to a voltage-controlled filter (VCF) will determine how much of the original signal will be

attenuated. The voltage to a voltage-controlled amplifier (VCA) determines the strength, or level of the signal.

Keyboards. There are a number of voltage sources that are used in synthesizers. The most common is the keyboard, which is similar to those found on pianos and organs. Figure 2 shows a simplified voltage control keyboard. Each switch is a key. If S1 is closed, none of the resistors are in the circuit, so the full five volts is available at the output. If S2 is closed, R1 is brought into the circuit, so the output voltage is dropped to a lower value. For this example, let's assume all four resistors are equal, and each has a one volt drop across it. This means that closing S2 produces a four volt output. S3 would bring both R1 and R2 into the circuit (in series, so their values add), so the output would now be three volts. S4 would bring 3 resistors into the circuit, giving a two volt output, and S5 is connected to all four resistors, giving an output of only one volt.

One important thing to notice with this kind of arrangement, is that only one voltage can be produced at one time. That is, the keyboard is monophonic. Polyphonic (multiple note) keyboards are used in commercially available synthesizers, but they are outside the scope of this article.

You can build a monophonic keyboard like Figure 1 from a toy organ keyboard. The switches marked B are for a trigger signal (explained later) which simply tells the synthesizer when a key has been depressed. There are two switches for each key.

The resistor values would be determined experimentally. The exact voltage doesn't matter so much as the pitch of the VCO, so you'd hook the keyboard to the VCO and try various resistors until it sounds right. You can use fixed resistors connected with spring clips, or potentiometers, which are more expensive, but give you precise control of the sound.

Sequencers. Another common voltage source is the

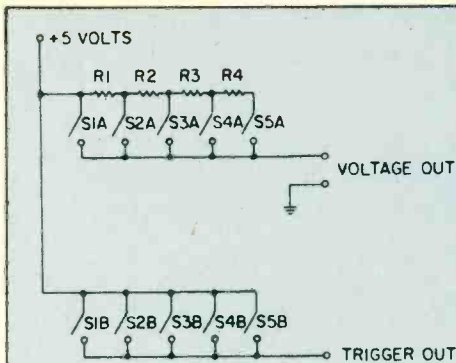

Fig 1. In this version of a simplified voltage keyboard, each switch is a key.

Complex in appearance but simple to understand, electronic synthesizers are not an avant-gard musical instrument. Today they are a permanent part of music and will no doubt remain there for quite a long time.

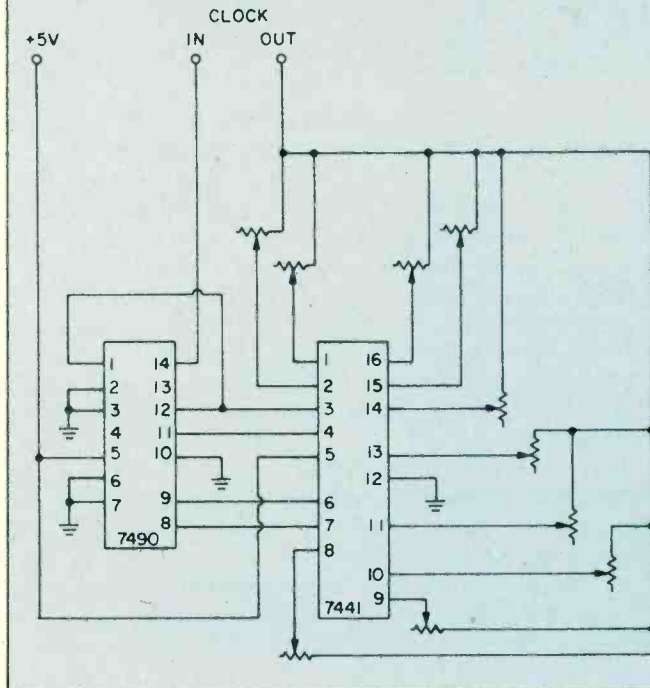
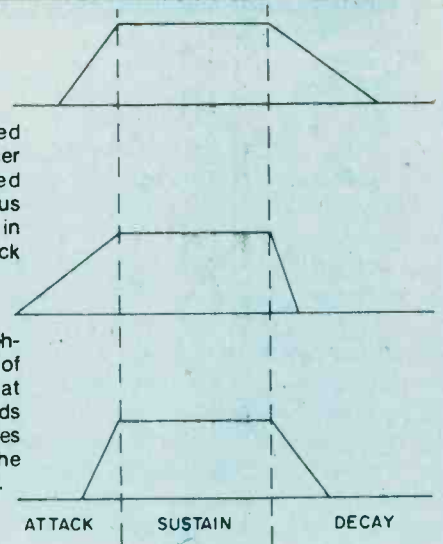

Fig. 2. This simplified schematic of a sequencer utilizes two integrated circuits to order various voltages that are used in producing music. A clock controls the sequence.

Fig. 3. These three sketches illustrate the range of envelope voltages that can be made. The speeds of attack and decay modes are controlled thru the envelope voltage mode.



sequencer. As the name suggests, this device produces a sequence of voltages. For example, a sequencer's output might be set to 5V, 4V, 3V, 3.5V, 3V, 2.5V, 3V, 4V. When the sequence reaches its last position, it loops back around and starts over.

A schematic for a simple sequencer is shown in Fig. 2. Note that the sequencer requires an oscillator to control it. This is not the VCO that produces the signal you hear. It is a separate oscillator, or clock, that controls the speed of the sequence, consisting of a low frequency square-wave.

As a matter of fact, a spare oscillator can also be used as a varying voltage source. If the controlling oscillator is a very low frequency you can hear its wave-shape (discussed below), but it is in the audible range, very complex tones can be produced.

Function Generators. Another varying voltage source is the function generator or envelope generator. When a function generator receives a trigger signal (such as from a keyboard's second set of switch contacts) its output voltage rises from zero to some specific maximum level (attack). The maximum level is usually held for as long as the trigger voltage is present (sustain). When the key is released, the voltage drops back down to zero (decay).

Figure 3 shows some typical envelopes. Figure 4 is the schematic of a simple function generator. Any of these voltages can control a VCO, a VCF, or a VCA, in any combination that you wish to try.

Synthesizing a Flute. For discussing the rest of the synthesizer, let's assume we want to synthesize a flute sound.

We start out with a VCO to produce the original signal. VCO's may produce any of a number of wave-shapes. The most common are shown in Figure 5. A sawtooth-wave has all of the harmonics. For example, if the frequency of the sawtooth is 100 Hz., then it will also contain tones at 200 Hz. (the second harmonic + 2 x 100), 300 Hz. (3rd harmonic + 3 x 100), 400 Hz. (fourth harmonic), 500 Hz. (fifth harmonic), and so forth. The ear automatically combines all of these tones into one raspy sound with an apparent pitch of 100 Hz.

A square-wave, on the other hand, only has odd harmonics. Again, assuming a fundamental frequency of 100 Hz., there will also be tones at 300 Hz. (third harmonic), 500 Hz. (fifth harmonic), 700 Hz. (seventh harmonic), and so on. The resulting sound is rather reedy, vaguely similar to an oboe.

A triangle-wave also contains all the odd harmonic,

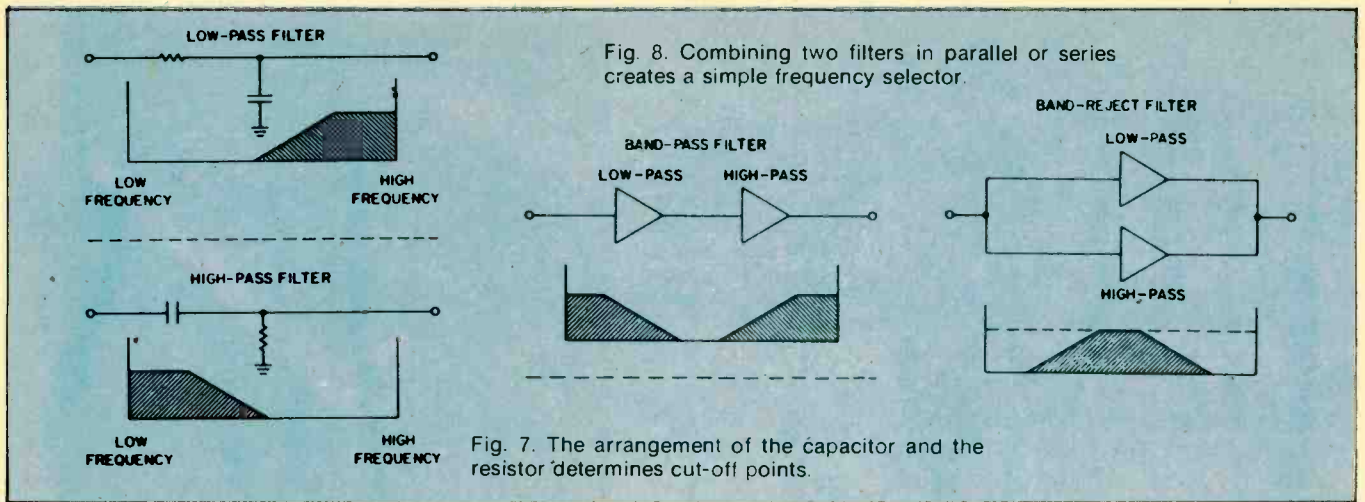

Fig. 8. Combining two filters in parallel or series creates a simple frequency selector.

Fig. 7. The arrangement of the capacitor and the resistor determines cut-off points.

but they are somewhat weaker than in a square-wave, so the sound is brighter.

A sine-wave has no harmonics, and the sound is very piercing. Actually, it is somewhat unpleasant to listen to by itself, so this waveform is usually only used as a fluctuating voltage source to control other modules for such effects as tremolo and vibrato.

Filtering. Since the sound of a flute is somewhere in between that of a triangle-wave and a sine-wave, we start out with a triangle-wave, and filter out some of the upper harmonics. (A square-wave could also be used, but more filtering would be required). For this purpose we would use a low-pass filter, which lets low frequencies pass through it, but blocks higher frequencies (i.e., harmonics). For most synthesizer uses low-pass filter is the handiest, but its mirror image, a high-pass filter can also be useful. If you combine these two basic filters as in Figure 8, you have a band-pass or a band-reject filter, so there are a number of effects that can be achieved.

The filters in Figure 7 are fixed filters. That is, their cut-off frequencies are determined by the components values, and remain constant unless the components are changed. This can be troublesome in a synthesizer. Let's say you want a sound with the fundamental, the third and the fifth harmonics only. If we start out with a 1,000 Hz. signal, the third harmonic is 3,000 Hz., and the fifth is 500 Hz. So we use a low pass filter to block everything about 5,500 Hz. Now, suppose we double the frequency and play a 2,000 Hz. note. The third harmonic would be unaffected at 4,000 Hz., but the fifth harmonic would be 6,000 Hz., which means it would be blocked by the filter. Or, if we reduce the frequency to 500 Hz., the filter will pass the fundamental (500 Hz.), the third harmonic (1,500 Hz.), the fifth (2,500 Hz.), and also the seventh (3,500 Hz.), and the ninth (4,500 Hz.). Obviously the sound can change quite a bit as the pitch varies.

The solution is to use a VCF, and control it along with the VCO. The patch is shown in Figure 9.

We now have a flute-like sound, but unfortunately, it won't sound very realistic, because each note will instantly be at its maximum level as soon as the key is depressed, and will instantly cut off when the key is released. Real-world sounds aren't like that, and the effect is terribly unnatural. Here is where the function generator and VCA come in. The new patch is shown in Figure 12.

Since the flute is a wind instrument, the sound will take some time to build up to maximum, as the player blows air through the tube. We can simulate this with a fairly slow attack. The sound will also take some time to die out when the player stops blowing, but not as long as it took to build. We'd use a moderate decay time. The envelope voltage applied to the VCA would look like Figure 13. When no key is depressed, the VCA is cut off. No sound is heard. When a key is depressed, the function generator is triggered. A changing voltage is applied to the VCA. The volume of the signal will vary in step with the voltage.

The noise generating circuit shown in Fig. 14 is a simple but important addition to the synthesizer. It makes for a great deal of flexibility and provides background noise for effect.

At this point we have a fair impression of a flute. Just how good it will sound will depend on the quality of the circuit. Those shown in this article are suitable only for experimentation.

We can do a little more to improve realism. For instance, we could add a little noise, as in Figure 15, to simulate the sound of the musician's breath. This noise should have a somewhat faster attack and decay, than the VCO signal, at a much lower level.

We could also add a tremolo (or fluctuating effect) by controlling the VCA with a very low frequency sine wave oscillator (about 5 or 6 Hz.). The bias is a manually adjusted negative voltage that is equal to the peak voltage of the sine wave. This is to cancel out the sine wave when the function generator is not triggered. Thus, the VCA will be cut off between notes.

Synthesizing a Drum. Now that we've synthesized a flute, let's go back to the patch in Figure 15. Would you believe this is the same patch you would use to produce a drum sound? In this case the level of the noise should be much higher than that of the VCO, and the envelopes would be changed to those of Figure 18A.

Figures 18B and 18C show additional envelope settings for unique sounds, not heard in nature. Even with this simple patch, many variations are possible. Besides changing the envelope, you could change the waveshape of the VCO, or substitute a second FCO for the noise generator, or use high-pass or band-pass filters instead of the low-pass module. You could also use a function generator (or oscillator) to control the filters, or

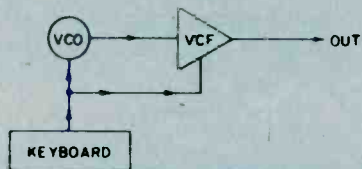

Fig. 9. Using a VCF with a VCO, the proper harmonics of an instrument can be created.

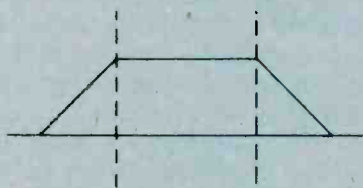

Fig. 10. A low-pass VCF is used to control frequency. Enclose photocell and lamp together.

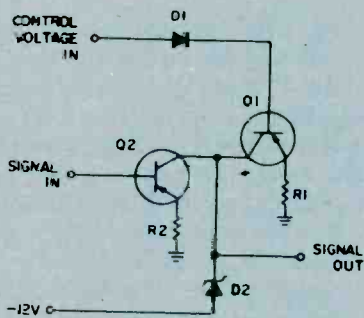

Fig. 11. A simple device, a VCA controls the volume generated so synthesized sound seems real.

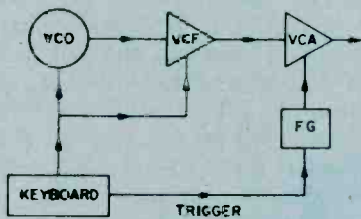

Fig. 12. This block diagram illustrates how the VCA control fits into the synthesizer.

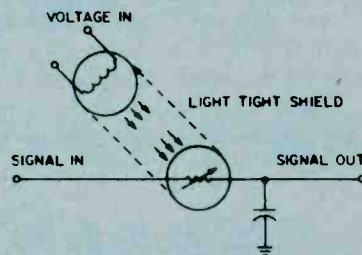

Fig. 13. The VCA has an envelope voltage, which is shaped like this, applied to it.

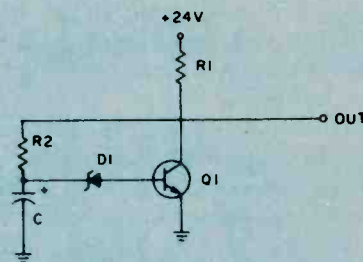

Fig. 14. The noise generator of the synthesizer provides background noise for effect.

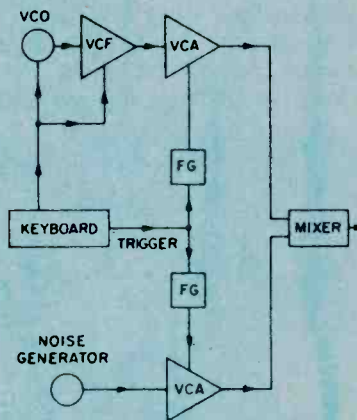

Fig. 15. Adding a little noise to the circuit adds strange qualities to the sound.

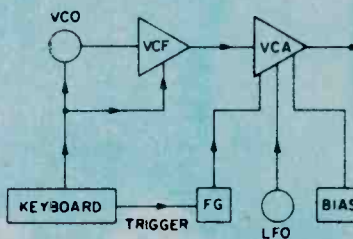

Fig. 16. A variation of the basic patch, which is given in Fig. 15, for the tremolo effect.

use your imagination.

As you can see, synthesizers really aren't as complex as they seem, yet you can get hours of pleasure out of the simplest collection of modules. Each variation in the way the modules are wired together, will give you a different audio effect. Think of yourself as the conductor who orchestrates the sounds of many musicians. With a

synthesizer, you have many more possibilities than with acoustic instruments. The latest trend in music is called New Wave. Its sounds are generated strictly from synthesizers, without any acoustic instruments being used. Eerie sounds seem to echo through distant galaxies, producing strange & hypnotic effects.

SOLAR POWER STATION

By the early 1900's, Israel expects to meet much of its electricity needs with solar generated power. An all solar powered 150 kilowatt generating plant was put into service in late 1979, and more ambitious projects are slated for the future.

The Ein Bokek project, located on the shores of the Dead Sea, makes use of the concept of the solar pond—a body of water whose salt content is such that the water in its depths rises to high temperatures—and a turbogenerator powered by this heat energy. The combination of these two relatively simple and low cost technologies has made possible an innovative approach to electricity production. This large scale application of solar technology is the first of its type.

Solar Priorities. The Israeli government was understandably interested in giving a high priority to the development of solar energy. Continuing hostility from the oil-producing Arab countries dictated energy conservation long before it became necessary for the rest

of the world. Israel was one of the first countries to take advantage of the abundant and free energy from the sun; nearly ever rooftop sports a solar water heater, with its distinctive panels and collecting tanks.

A 15,000 square foot solar pond was constructed at Ein Bokek by excavating an area of the Dead Sea shore, damming the seaward side, and lining the excavation with a black, heat-absorbing rubber substance. Water was let in, and its salinity level was constantly monitored to ensure that the proper gradient level would be reached. The high salt and mineral content prevents normal convective cooling, and the salinity increases with depth. The water at the bottom of the pond rose nearly to boiling temperature after a few hours under the desert sun.

The hot water was then circulated through a heat exchanger, where it heated an inorganic working fluid to the gaseous state. This gas powers a turbine attached to an electric generator.

The turbogenerator system that converts the heat of the solar pond into electricity is a unit known as the Ormat Energy Converter (OEC). This is a low-temperature, low-pressure generating system that was originally designed to produce electricity from waste heat. It uses a closed system wherein the working fluid is heated up, used to run a turbine, then condensed and used over again. The OEC is ideal for use in applications where a constant 175-200°F heat flow is available.

Encouraged by the success of the pilot plant at Ein Bokek, the Israeli government has the project's two contractors, Ormat Turbines and Solmat Systems, at work on a 5,000 kilowatt power station. This generating station should be operational by 1981, and will be the first module of a system with an eventual capacity of 2,000 megawatts. Meanwhile, the Ein Bokek plant has been constantly producing 150 kilowatts, day and night, winter and summer. The Dead Sea is a body of water approximately 50 miles long and 11 miles wide: an enormous potential for electricity generation!

A Practical Energy Source. Solar ponds occur naturally in many parts of the world, including the U.S., and they can be man-made as well. While the Ein Bokek project was built in an area where temperatures in excess of 100°F are common, the solar pond is equally viable in more temperate climates.

This ambitious Israeli project is just one example of how the dependence on expensive and potentially hazardous energy sources can be offset by solutions developed from Nature. ■

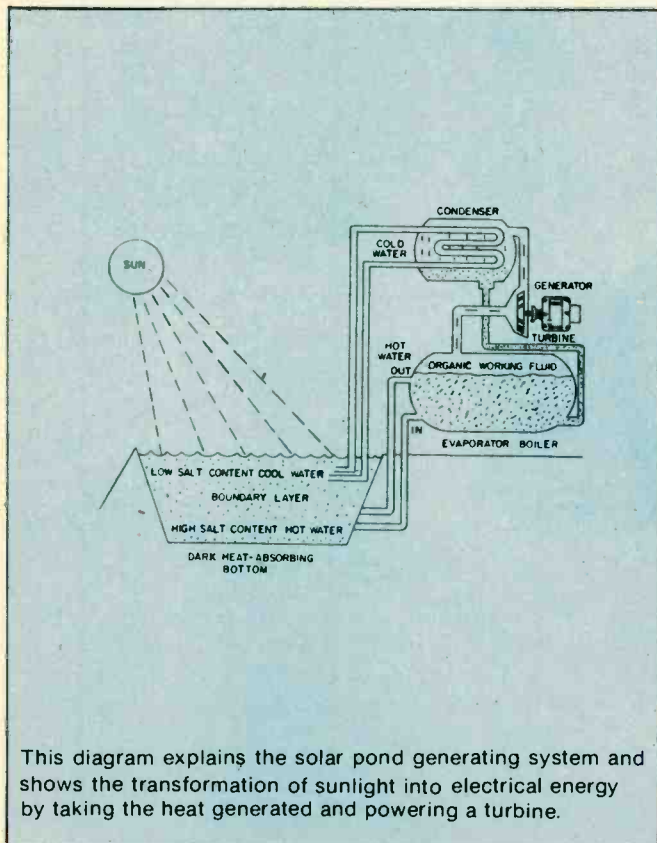

This diagram explains the solar pond generating system and shows the transformation of sunlight into electrical energy by taking the heat generated and powering a turbine.

POWER SUPPLIES FOR IC CIRCUITS

Recently I ordered a single-board computer that is used as a development system and trainer. It is a good microcomputer trainer and is used by many schools.

I was ready to begin fingerboning 6502 commands into the microcomputer when I noticed that the machine had no power supply. In my haste to get into this type of microcomputing, I had overlooked the power supply. The company price list revealed a power supply, but it cost \$50. Since it was only a 5-VDC, 4-amp, with ± 12 -VDC, 500-mA on the side, it was easy to beat that \$50 price.

There are several popular circuits used in power supplies for typical low to medium current range microcomputers. For really big computers, which require 25-ampere supplies, we will defer to the makers of commercial supplies.

The S-100 is probably the most popular mainframe microcomputer on the hobbyist market. Also, there are plenty of industrial, scientific and engineering computers on-line and many of them are S-100 machines.

The S-100 system utilizes distributed voltage regulation. All digital devices, especially, TTL, require regulated DC power supplies. One approach is centralized regulation. In these machines, there is a 5-volt DC high current power supply located somewhere in the machine. It will supply the same power to all printed circuit cards plugged into the microcomputer's motherboard.

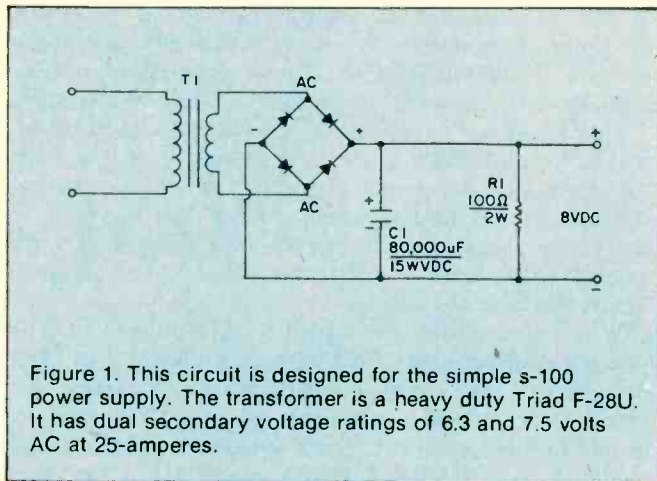

Figure 1. This circuit is designed for the simple S-100 power supply. The transformer is a heavy duty Triad F-28U. It has dual secondary voltage ratings of 6.3 and 7.5 volts AC at 25-amperes.

Lots of Current. It seems that a problem with a centralized system is that the voltage can be 5-volts only at one system location. Since these supplies draw large amounts of current there will be a sufficient voltage drop in the printed wiring tracks to reduce the voltage below the viable level for TTL devices (4.5 to 4.75 volts).

Some power supplies, those that use feedback type regulators, have a sense line sampling the output voltage. These power supplies are a little more useful because the sense line can be connected to the point on the motherboard where the voltage level is critical. The power supply will then attempt to keep the voltage at 5 volts DC at that point.

But at all other points, the voltage will be higher or lower, depending upon where the 5-volt line is connected to the PC board and how far that point is from the point of measurement. In my own Digital Group, Inc. Z-80 system, I measured the voltage at 5.25 at one point, and 4.8-volts at the far end of the system. If it had been any lower at the extreme end, some of the memory devices may have trouble functioning properly and if any higher it would have burned out TTL devices right and left.

Another problem with the centralized regulator system is the power supply cost. A 5-volt DC, 15-ampere power supply can cost a lot more than building an unregulated 8-volt S-100 power supply and then using buck apiece 1-ampere, 5-volt three-terminal regulators on each card.

Disaster. One final problem with the central method is the parts replacement cost if something should go wrong. If the series pass element of the power supply shorts or if the voltage reference element goes open, both events will cause the full unregulated power supply input voltage (8 volts on the S-100) onto the 5-volt bus—with disaster following for the TTL devices on the board.

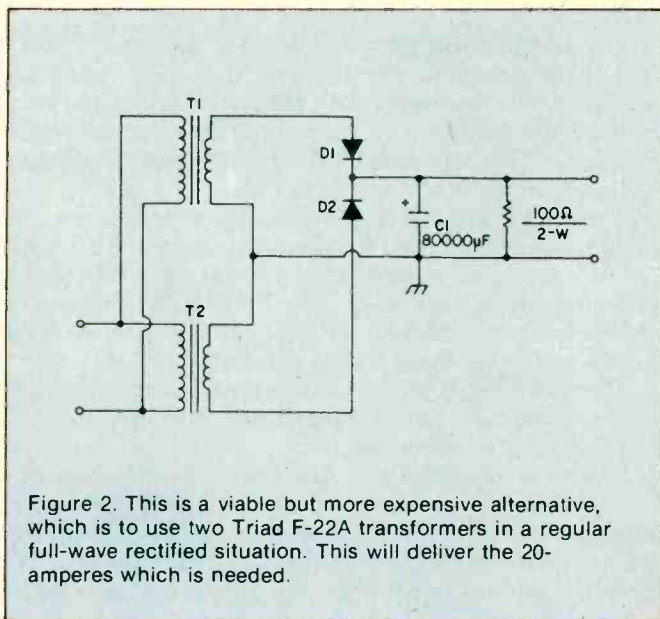

Figure 2. This is a viable but more expensive alternative, which is to use two Triad F-22A transformers in a regular full-wave rectified situation. This will deliver the 20-amperes which is needed.

When one of these big supplies opens up a shotgun blast of high voltage, there might be significant damage before the overvoltage protection circuit works. The higher the input voltage, with respect to the output (5-VDC) line, the worse the damage. On the S-100 type of power supply, only the devices on the offending regulator are affected. While the other scheme could wipe out the entire system, the S-100 will burn up only the devices on the single board.

The problem is that we need to supply the 8-volts DC required by the array of three terminal 5-volt DC regulators used on S-100 boards. Furthermore, this voltage must be backed up with not less than 10 amperes of current for even moderate systems. For some systems,

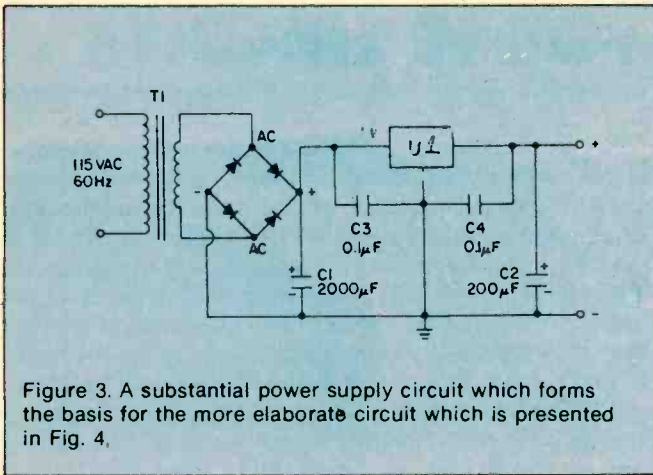

Figure 3. A substantial power supply circuit which forms the basis for the more elaborate circuit which is presented in Fig. 4.

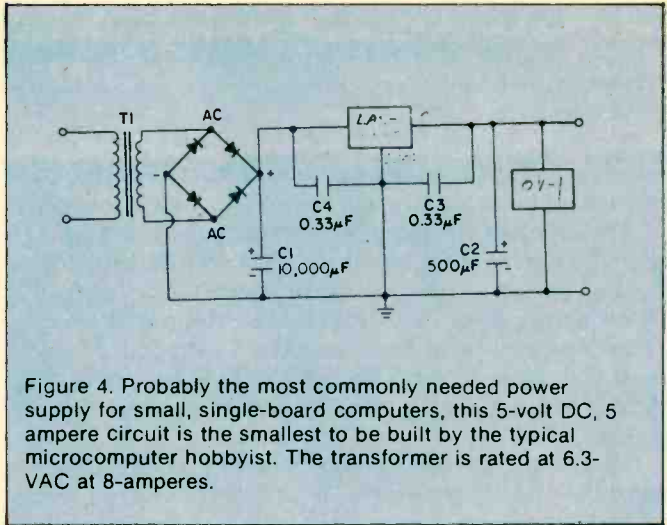

Figure 4. Probably the most commonly needed power supply for small, single-board computers, this 5-volt DC, 5 ampere circuit is the smallest to be built by the typical microcomputer hobbyist. The transformer is rated at 6.3-VAC at 8-amperes.

even more current is required.

Fig. 1 shows the circuit for the simple S-100 power supply. I have built this circuit into a Vector cabinet containing the Vector S-100 motherboard and there was plenty of room. Keep in mind when you use this cabinet, however, that the aluminum used in its construction will not support the transformer that I specify here. Place a piece of 3/8-inch ply wood between the main support struts to support the transformer. Alternatively, cut up a 5- to 7-inch high piece of 19-inch rack panel to make the support.

The transformer specified here is the Triad F-28U. This heavy duty device is rated at 6.3/7.5 VAC, 25-amperes. The dual secondary voltage rating is one factor making this transformer more useful to microcomputer builders. The regulators used in S-100 require at least 8 volts DC at their input to operate.

Under fully loaded maximum current conditions, this level is sometimes hard to maintain using just a 6.3-VAC transformer, as we have only an 800-millivolt margin allowing for voltage drop. The 7.5 volts AC, however, will, when rectified, keep us in the gallgame. The voltage is selected using the primary winding.

There are three lines to the primary: a common and two voltage taps. Select the primary tap that yields 7.5-VAC across the secondary.

Bridge Rectifier. Since this transformer is use in a bridge rectified situation, we cannot legally draw more than one-half of the 25 amperes it is rated to deliver. This 12.5 amperes will supply many small S-100 systems, but is insufficient for larger ones. We can stretch the point by properlyf cooling the transformer. Overheating is due to exceeding the transformer's primary rating.

I have used this same transformer at 20-amperes in a bridge rectified situation and it ran cool, because I placed a 100 c.f.m. muffin fan a few centimeters from the transformer. Place the fan so that it will blow along the same line as the laminations to maximize cooling. This will allow the air to blow into the windings, not into the fish papr covering on th outside of the winding.

The rectifier is any of the 25-ampere, 50 volt PIV (or more) stacs that are available. I used the General Electric GEBR-425 device. Be a little wary of some companies' ratings in this type of device; they tend to be optimistic to your detriment. I heat-sinked the rectifier using one of the larger finned aluminum sinks designed to TO-3 transistors (but undrilled to I could customize it for the

rectifier).

The rectifier/heatsink combination was positioned so that the air from the fan would also blow over the heatsink, improving heat transfer. Silicone heat transfer grease was used on the surface of the mounted rectifier.

The capacitor is probably the single most important part of this power supply. The nominal rating is given at 2000-uF to 50,00-uF range, depending upon whether or not you attempt to get the entire 25 amperes out of the transformer. But this is a minimum and in the case of the S-100 system, I doubt the wisdom of the standard because of the distributed regulation system used.

I prefer to use as much capacitance as I can obtain. For my own power supply, I found an 80,000-uF at 15-WVDC computer grade capacitor at a local distributor. My recommendation is some value of capacitance between 75,000-uF and 200,000-uF even if two or more units have to be wired in parallel to achieve the value.

Small Load. The 100-ohm resistor is used to place a smallminimum load on the power supply. It was found that output voltage was over +12 volts under no load conditions and that seemed a little too close to the working voltage of the filter capacitor. As a result, I tried various values of load, and found that 100-ohm, 2-watt seems the best solution.

When wiring this power supply, remember that when you are dealing with a high current situation. Use heavy duty wire and wire connectors in this supply. I recommend at least 8-gauge wire, or, two 12-gauge wires in parallel, for each run. Such wire sizes are not usually available in radio-TV parts distributors, but auto parts stores almost always carry them.

There are several alternatives to the transformer selected for this project. You could, find a surplus transformer rated at 6.3 or 7.5-VAC at bunches of current. These transformers are popular with the designers of high power radio transmitters as filament transformers and are occasionally seen in electronic surplus stroes or in the hamfest markets. Or you could use the Triad F-22A transformers.

This is a 6.3-VAC, 20 ampere model, so is rated slightly lower than the F-28U that was specified. It will deliver 10 to 20 amperes in the bridge configuration, depending upon how brave you are. A viable, if expensive, alternative, is to use two Triad F-22A transformers in a

regular full-wave rectified situation (see Fig. 2). This will deliver the 20 amperes required. In this circuit, the primary windings are connected in parallel, while the secondaries are connected in series.

If you accidentally connect the secondaries backwards, then the output voltage will be zero. In that case, reverse the connections of either the primary or the secondary of one of the transformers. The problem is phasing the AC sine wave properly. Diodes D1 and D2 are stud-mounted 50 volt PIV, 25 ampere (or more) types. Again, the rectifier should be sturdily heatsinked.

Low Grade Supply. This power supply project is probably the lowest grade power supply that will be useful to microcomputerists. It is useful for small digital projects of any type using TTL (or CMOS operated at 5-VDC) and some of the smaller single board computers. The transformer can be any 6.3-VAC filament transformer rated at 2 amperes or more.

The rectifier is a bridge stack rated at 50 volts PIV, 1 ampere or more. The capacitor used in the filter fills the 2000-uF/ampere rule, although it would not hurt to use more capacitance. The output capacitor is strictly optional, although recommended because it improves the transient power supply response. It has a value that follows the rule 200-uF/ampere. It will be happy with any value from 100 to 500-uF.

The small value capacitors are used to improve the immunity of the regulator to noise on the input voltage line and from within the computer. These capacitors should be mounted as physically close to the regulator as possible. Most builders place them directly on the regulator terminals.

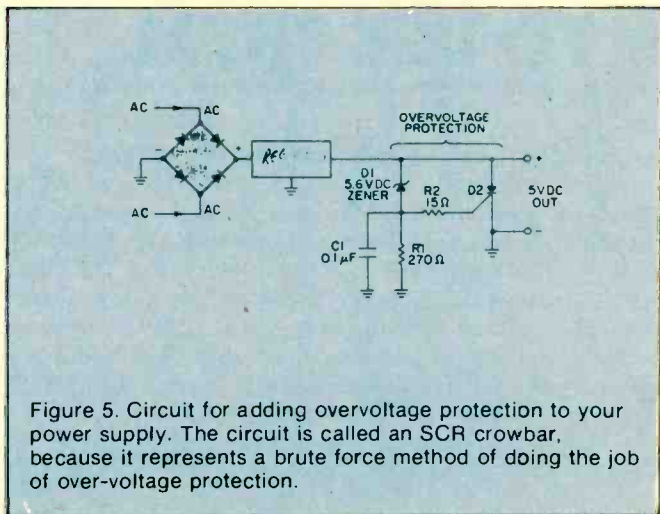

Figure 5. Circuit for adding overvoltage protection to your power supply. The circuit is called an SCR crowbar, because it represents a brute force method of doing the job of over-voltage protection.

The regulator itself can be any of the standard three-terminal 5 volt IC regulators: LM-309, 7805, LM-340-5, etc. Avoid the plastic TO-220 package types, as they should be limited to 750-mA unless well heatsinked.

Common Power Supply. The 5-volt, 5-ampere power supply (see Fig. 4) is probably the most commonly needed on small single-board computers.

The transformer for this power supply is rated at 6.3 VAC/8-amperes.

There are also several regulators now on the market that will hack at 5 amperes. The regular that was selected was the Lambda Electronics, Inc. (515 Broad Hollow Rd., Melville, N.Y., 11746) type LAS-1905.

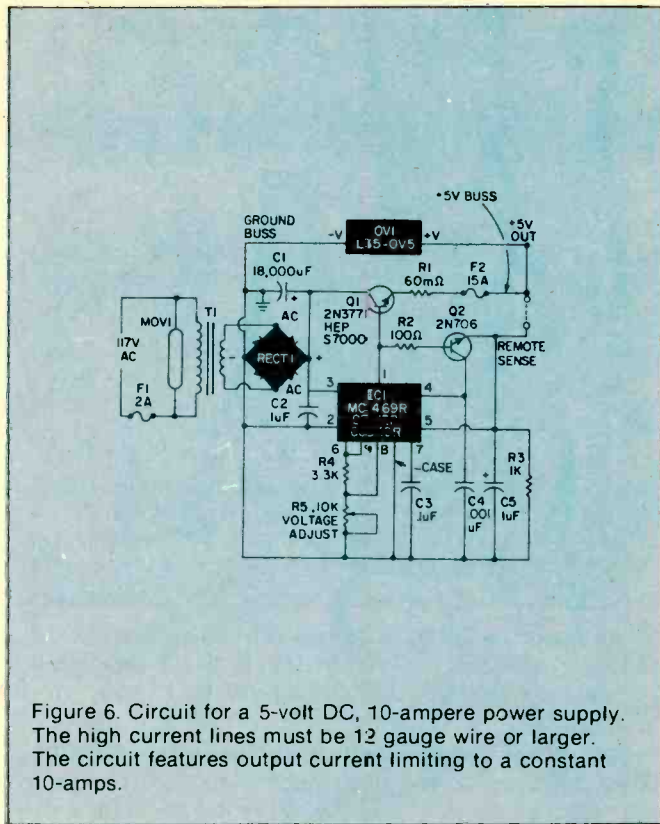

Figure 6. Circuit for a 5-volt DC, 10-ampere power supply. The high current lines must be 12 gauge wire or larger. The circuit features output current limiting to a constant 10-amperes.

The rectifier used is the same 25 ampere rectifier as used in the S-100 power supply project.

Follow The Rule. The filter capacitor (C1) follows the 2000-uF/ampere rule, so a 10,000-uF unit was selected. Note that 8000-uF/25-WV-DC is commonly available.

The device labeled OV-1 in Fig. 4 is an over voltage protection module made by Lambda. These devices are designed to trip at 6.6-volts and will short the power supply line to ground if the voltage reaches this point.

If you wish to build your own overvoltage protection circuit then try something like the circuit in Fig. 5. The circuit is called an SCR crowbar, probably after the fact that it represents a brute force method of doing the job. Diode D2 is a silicon controlled rectifier (SCR) and is rated to handle at least the current of the power supply. It is connected in parallel across the +5-volt DC output lines, but remains inert until a voltage appears at the gate terminal.

This triggering voltage is supplied by Zener diode D1. At potentials less than 5.6-volts, the normal TTL operating range, the zener will not conduct current. But, at potentials greater than 5.6-volts DC the Zener conducts and creates a voltage drop across R1 that will fire the SCR. When the SCR turns on, the output lines of the power supply are shorted by ground. This will blow the primary fuse or burn out the transformer if there is no primary fuse.

10 Amp Supply. Fig. 6 shows the circuit for a 5 volt, 10-ampere power supply. This is the circuit that I used on my first Digital Group, Inc. computer. The regulator is a Motorola MC1469R (HEP C6049R also works). There are two suffixes available for the MC1460; buy the one with the R otherwise, the rating is too low. This device is a 500-mA regulator but is insufficient to power the computer. We can boost the output current by using the

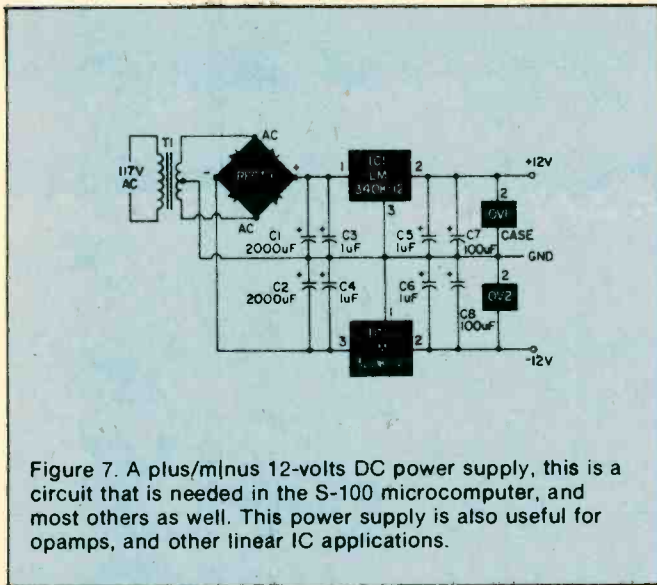

Figure 7. A plus/minus 12-volts DC power supply, this is a circuit that is needed in the S-100 microcomputer, and most others as well. This power supply is also useful for opamps, and other linear IC applications.

IC regulator to control the base circuit of a series-pass transistor (2N3771). The heavy lines in Fig. 6 are the high current lines and there must be 12 gauge wire or larger.

This power supply features output current limiting, which means that the maximum output current, even into a short circuit, will be 10-amperes. The active element in the current limiter is transistor Q2. The base-emitter bias of this transistor is the voltage drop across the 60-milliohm (R1) resistor in series with the emitter of

Q1. When the current reaches 10 amperes, the voltage drop is 0.6 volts, which is sufficient to turn on Q2 and shut down the supply. You can make a 60 milliohm resistor by connective five 0.33 ohm auto radio fusistors in parallel, or by winding one of fine gauge wire yourself.

The exact output voltage can be adjusted using potentiometer R5. Set the output voltage as close to 5.0 volts as you can.

The last power supply that we will consider here is the ± 12 VDC, 1 ampere circuit shown in Fig. 7. This circuit is also needed in the S-100 microcomputer and most others as well. The transformer is a Triad F-56X (or equivalent), rated at 25.2 VAC at 2.8 amperes. The extra 800-mA gives us a margin of safety. Nowt: when buying the transformer for this supply, make absolutely sure that the transformer that you buy has a centertapped secondary!

The rectifier is a 2-amp or greater bridge stack rated at 100 WVDC or more. Note that we are not using the rectifier as a fullwave bridge, but as a pair of half wave bridges, with the transformer center tap as the zero-volt reference. The output of one half-bridge will be negative to ground, while the other is positive to ground.

The filter capacitors are selected for the 200-uF/ampere rule, but should be higher because this circuit uses halfwave rectifiers. I recommend that you use 2000-uF for light-duty loads, but 3000-uF or 5000-uF or more for the full 1-ampere per side. This will compensate for the halfwave voltage rectification.

This power supply is also useful for operational amplifiers, and other linear IC applications. ■

OP-AMPS — HOW TO USE THEM

Few linear, (non-digital) integrated circuits (ICs) have achieved the wide popularity of the op amp in hobbyists projects of every description. Combined with few other circuit components, the op amp circuit vastly outperforms the multiple transistor circuit of yesteryear. Because you will encounter the op amp time and time again in many circuit applications and may desire to work up your own op amp circuits, it is essential to become familiar with the device.

This will introduce you to the basics of op amp circuits and applications. Four simple rules of operation are logically applied to trace and deduce the operation of the basic linear op amp circuits. Test circuits are included for "hands on" familiarity. Only a few mathematical relationships are listed to effect a comparison of the several circuits.

Some Basics. As shown in Fig. 1a, the op amp has two input terminals and one output terminal. A plus sign at one input identifies the *non-inverting* or "follower" input. When this input goes positive (with respect to the other) the output voltage, V_{OUT} , also goes positive, thus "following" the polarity of the input. The minus sign at the other input identifies the *inverting* input. When this input goes positive (with respect to the other), V_{OUT} goes negative, thus "inverting" the polarity of the input. In technical terms, the input stage of the op amp is a balanced "differential input" amplifier and is one which

responds to the *difference* between the voltages.

Output voltage V_{OUT} equals V_{IN} times $AVOL$ ($AVOL$ equals the open-loop voltage gain as listed on spec sheets for the op amp used). Input impedance (AC resistance) Z_i and output impedance S_{oi} are shown in Fig. 1b. These are the primary characteristics of the op amp. If a perfect op amp could be constructed, $AVOL$ and A_i would be infinitely large and Z_{oi} would be zero. Actually, for a general purpose 741 op amp, $AVOL$ equals 200,000, Z_i equal 2 megohms, and Z_{oi} equals 74 ohms.

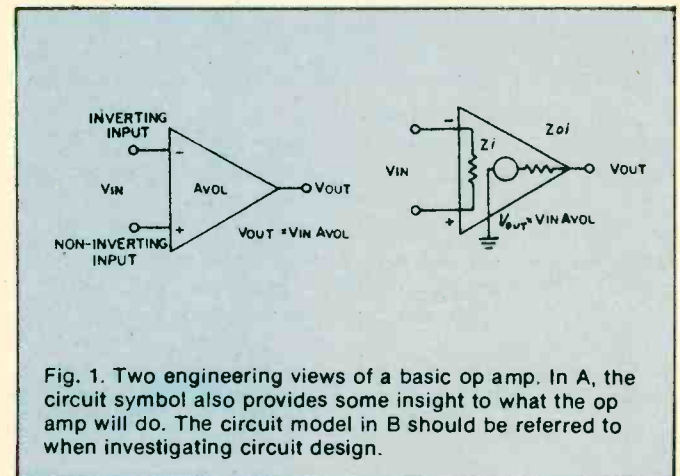

Fig. 1. Two engineering views of a basic op amp. In A, the circuit symbol also provides some insight to what the op amp will do. The circuit model in B should be referred to when investigating circuit design.

Important Concept. In linear applications such as an AC or DC amplifier, the op amp is operated closed-loop with negative feedback. To do this, the loop is "closed" by connecting a feedback circuit from the output terminal to the *inverting* input; this results in negative feedback. That portion of the output voltage fed back to the input tends to negate, or oppose, the applied input signal voltage. As will be shown later, the resulting closed-loop gain, AV_{CL} , is very much smaller than the open-loop gain. Also, the closed-loop gain now depends on the particular feedback circuit itself and not on the actual value of the open-loop gain. This makes it possible to build amplifiers with precise closed-loop gains. Among other beneficial effects, negative feedback imparts high linearity and stability to the amplifier.

Rules Of Operation. A few basic facts of op amp operation will be stated as rules and applied to the operation of several circuits. The implications and meanings of these rules will become clear as you apply them to the circuits.

1. The *difference* in voltage between the + and - input terminals is always small and can be assumed to be zero. (This fact is a direct result of very high AV_{OL} .)

2. The current entering the + and - input terminals is small and can be assumed to be zero. (This rule is a direct result of a very high Z_i .)

3. If the + input terminal is at ground voltage or zero, the - input terminal can be assumed to be virtually at ground voltage or zero. (This rule is also a direct result of high AV_{OL} .)

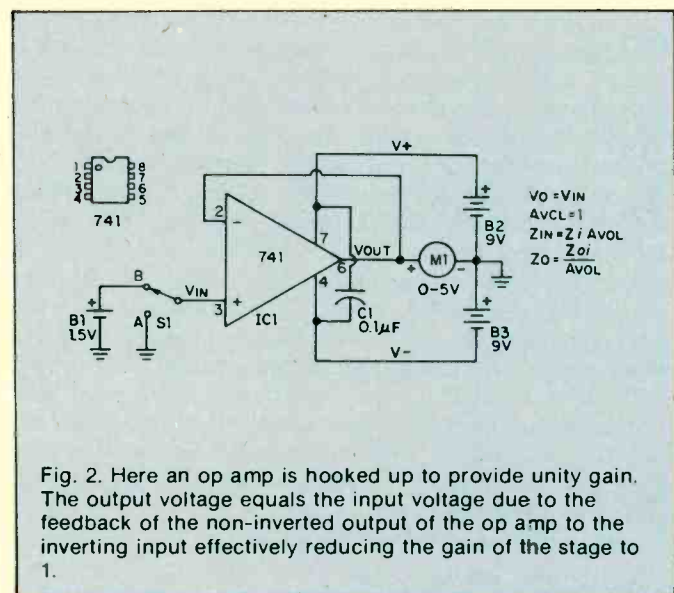

Fig. 2. Here an op amp is hooked up to provide unity gain. The output voltage equals the input voltage due to the feedback of the non-inverted output of the op amp to the inverting input effectively reducing the gain of the stage to 1.

4. When an op amp is connected in a negative feedback configuration, a voltage change at the + input must result in an equal voltage change at the - input terminal. (This is a description of rule 1 in operation.)

Setting Up. Breadboard the op amp circuit shown in Fig. 2. You can use perforated board and flea clips to assemble the circuit. Better still, use a solderless breadboard kit. Use only the 741 op amp for IC1. These are short-circuit proof and are internally frequency compensated to prevent oscillations. Switch S1 may be simulated by a clip lead.

Install disc capacitor C1 as close as possible to the IC.

Use either a common tie point for all ground connections or a heavy ground bus. Keep the input lead wires well separated from the output lead wires. The prototype breadboard uses a 50 μ A DC meter connected in series with a 100,000-ohm, 1% resistor for meter M1. Alternately, you can use your VOM (1000 ohms/volt or better) to measure output voltage. Use two fresh nine-volt transistor batteries for B2 and B3 and 1½ volts (an AA cell) for B1.

• **Unity Gain Follower.** Simplest of the op amp circuits, the unity-gain follower shown in Fig. 2 has a direct connection from output to the inverting input. This provides one-hundred percent negative feedback. With switch S1 at position A, the + input is grounded and meter M1 indicates zero. By rule 3, the - input is at virtual ground. Therefore, V_{OUT} is also at virtual ground. With S1 set to position B, the meter now indicates the voltage of battery B1, near 1.5 volts. By rule 4, the 1.5 volt increase at the + input must be accompanied by a 1.5 volt increase at the - input. Hence, V_{OUT} must rise to 1.5 volts.

The resulting closed-loop gain, or AV_{CL} , is unity (one unit out for one unit in). However, the high AV_{OL} inside the IC itself is still present, enforcing close compliance with the several rules. As noted on Fig. 2, actual input and output resistances Z_{IN} and Z_o are much improved due to feedback. The resultant input resistance now equals Z_i times AV_{OL} or 400,000 megohms for the 741 op amp! The resultant output resistance now equals Z_{oi} divided by AV_{OL} , or .0035 ohms! Consequently, the unity gain

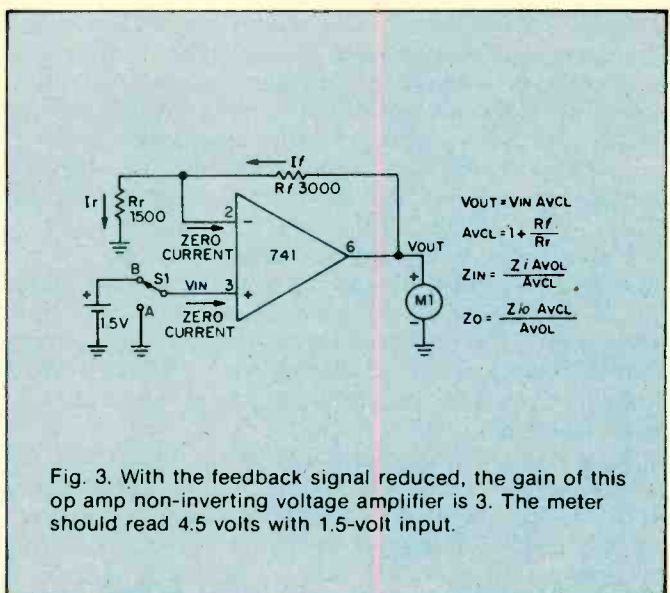

Fig. 3. With the feedback signal reduced, the gain of this op amp non-inverting voltage amplifier is 3. The meter should read 4.5 volts with 1.5-volt input.

follower can duplicate the input voltage at its output without loading down the input voltage source due to the high input resistance and with high accuracy due to the low output resistance. Actually, input and output resistances are degraded somewhat by secondary factors. Nevertheless, this unity gain follower offers the highest input resistance and lowest output resistance of the several basic circuits.

• **Non-Inverting Voltage Amplifier.** Stable op amp voltage amplification is obtained by feeding back only a portion of the output voltage. Alter your breadboard circuit to include feedback voltage divider resistors R_f

and R_r , as shown in Fig. 3. With R_f equal to $2R_r$, only one-third of the output voltage is fed back to the inverting input.

With S1 at position A, the + input is at ground voltage and the meter indicates zero. By rule 3, the - input is at virtual ground or zero. With zero voltage across R_r , current I_r is zero. In view of rule 2, I_f always equals I_r and is zero in this case. With zero current in R_f , the - input and the output voltage must be equal and zero in this instance.

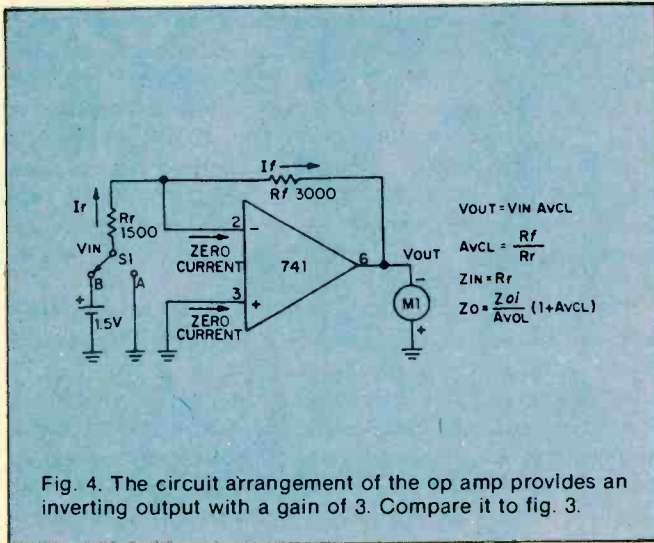

Fig. 4. The circuit arrangement of the op amp provides an inverting output with a gain of 3. Compare it to fig. 3.

With S1 at position B, the + input is raised 1.5 volts and the meter indicates 4.5 volts. By rule 4, the - input must rise to 1.5 volts matching that at the + input. The op amp does this by forcing a current into the feedback voltage divider as shown. With 1.5 volts across R_r , current I_r equals 1.5 volts divided by 1500 ohms, or 1 mA. Also, the voltage across R_f equals 1 mA times 3000 ohms or 3 volts. Thus, V_{OUT} equals 1.5 plus 3 or 4.5 volts.

Closed-loop voltage gain AV_{CL} equals $1 + (R_f/R_r)$ or 3 in this case. Compared with the unity gain circuit, actual output resistance Z_o is three times greater and input resistance Z_{IN} is one third that of the unity gain circuit. This reflects the effect of feeding back 1/3 of the output voltage. To obtain a closed-loop gain of ten, resistor R_f must equal $9R_r$, and so forth.

● **Inverting Voltage Amplifier.** Alter the breadboard circuit to that of Fig. 4 including reversal of the meter. With S1 at position A, the meter indicates zero. The proof of this result is identical to that of the non-inverting voltage amplifier with switch at position A. With S1 at position B, the meter indicates 3 volts (actually, minus 3 volts since the meter is now reversed).

In this case, the - input does not rise to 1.5 volts. By rule 3, with + input grounded, the - input must remain at virtual ground. Therefore, and quite importantly, the voltage across R_r equals the input voltage, or 1.5 volts divided by 1500 ohms, or 1 mA, flowing in the direction shown. Since I_f equals 1 mA times 3000 ohms, or 3 volts. With the - input at virtual ground, the output voltage must be minus 3 volts as indicated on the reversed meter.

The closed loop voltage gain, AV_{CL} , is simply R_f/R_r , or 2 in this case. Quite unlike the previous cases, actual input resistance Z_{IN} equals R_r , the input resistor.

Compared with the unity gain non-inverting amplifier, actual output resistance Z_o is greater by a factor of $(1 + AV_{CL})$ or three times as much, still acceptable small at this (and even much higher) gain.

By connecting additional input resistors to the - input and upon applying several input voltages, the amplifier will sum the several input voltages at the output. For this reason, the amplifier is often termed a summing amplifier and the - input is termed the summing node or input.

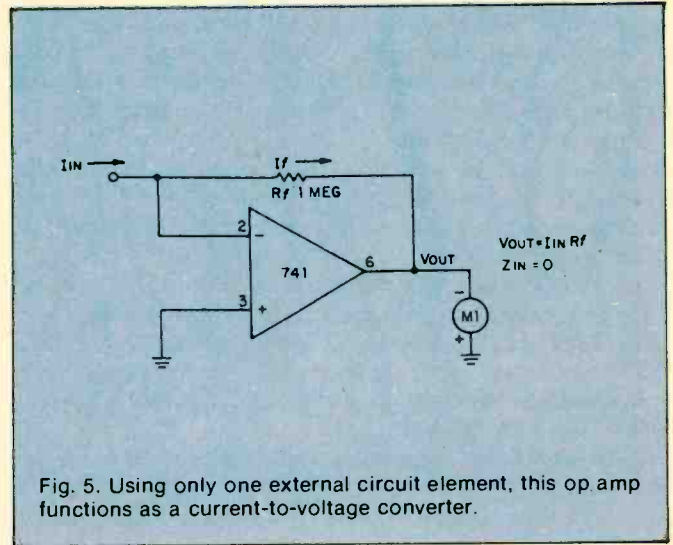

Fig. 5. Using only one external circuit element, this op amp functions as a current-to-voltage converter.

● **Current to Voltage Converter.** A variation of the inverting amplifier, the current to voltage converter shown in Fig. 5, omits input resistor R_r . Because the - input must remain at virtual ground for linear operation, this circuit cannot accept an input voltage. Instead, it accepts an input current and is used to measure very small currents. If I_{IN} were 1 microA, the output voltage would be 1 microA times 1 megohm, or 1 volt. By making R_f very large, the circuit can measure extremely small currents. The input resistance of this circuit is zero. The output voltage, V_{OUT} , equals I_{IN} times R_f .

If you breadboard this circuit, you may observe a small output voltage at zero input current. This output "offset" voltage is caused by the flow of a small bias current from output to input through the large feedback resistor, R_f . Unless special op amps having very low bias currents are used, it is necessary to include a nulling circuit to reset.

● **Input Bias and Offset.** Although rule 2 assumed zero input currents, an op amp does require a small input current I_b to bias the input stage into linear operation. For the 741, I_b may range up to $.5 \mu A$. The difference between the input bias currents at the two inputs is the input offset bias current z_{iio} . This current is usually much smaller than I_b . Both I_b and I_{io} cause an objectionable output offset voltage with R_f is very large. To restore the output voltage to zero, add the nulling circuit potentiometer R_1 and resistor R_2 as shown in Fig. 6. With S1 open, adjust the control until meter indicates zero.

If R_r is small, and upon closing S1, you may observe that the meter again loses its zero. This is caused by the input offset voltage V_{io} resulting from slight mismatches of the input transistors. Input offset voltage V_{io} is

defined as that input voltage required to restore V_{OUT} to zero. It is measured under open-loop conditions with very low value resistors at the input. For the 741, V_{io} may range up to 6 millivolts. Conveniently, the 741 includes terminals allowing compensation for input offset voltage. Add potentiometer R_3 and adjust the control with S_1 closed, until the meter indicates zero. If both circuits are included, adjust the controls several times in succession.

Conclusion. Having become acquainted with the basic operation of the op amp, and with some knowledge of the six primary op amp specifications, you will now be able to experiment with op amp circuits with some degree of confidence rather than apprehension. With some appreciation of how and why the circuit functions as it does, how the performance of the several circuits compare with each other, and how negative feedback plays its part, you will find that op amp literature and circuits are more easily understood. ■

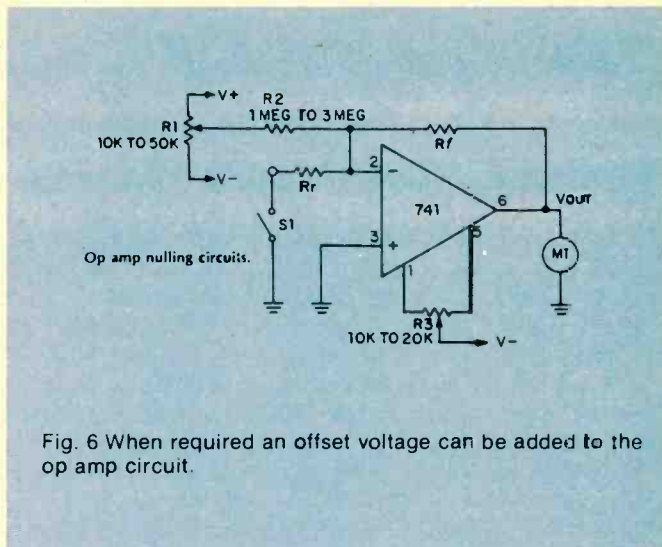

Fig. 6 When required an offset voltage can be added to the op amp circuit.

AMPLIFIERS THAT OSCILLATE

As any slightly cynical experimenter can tell you, if you want an oscillator, build an amplifier—it's sure to oscillate. Conversely, if you want an amplifier, (this same cynic will tell you), build an oscillator—it's sure to fail to oscillate, and you can then use it as an amplifier! This is well known as a corollary to Murphy's famous law, "If anything *can* go wrong—it *will*!"

Our informed cynic must have had long and unhappy experience with negative-feedback amplifiers, which are known to have at least two outstanding characteristics:

1. They function beautifully if carefully designed and built.
2. Otherwise, they oscillate!

Why do they oscillate? Or, more basically, how does a feedback amplifier differ from an oscillator?

The fundamental block diagrams of an oscillator and an amplifier with feedback bear a strong resemblance to each other, as you can see from Fig. 1. From a block diagram viewpoint, both diagrams are *very* similar. Both contain some type of amplifying device, and both have part of their output signal fed back to their input. There are only two major differences between them:

1. The amplifier with feedback contains an *inverting* amplifier; the oscillator contains a *non-inverting* amplifier.
2. The oscillator doesn't have an input.

The circuit action obtained from these two circuits is entirely different. In the amplifier with feedback, the output waveform is upside down with respect to the input, so when it is fed back to the amplifier input, it cancels a portion of the input waveform. The output is therefore less than it would be without feedback. See Fig. 2.

The feedback signals from inverting amplifiers are not "in phase" with the input signal and subtract (or reduce) the input signal level to the amplifier. When a feedback signal does this, it is called *negative feedback*.

So Why Negative Feedback? Of course, if you merely want the biggest possible gain for your money, negative feedback's not your game. However, negative feedback

offers other advantages, which can be summed up by saying that the amplifier's output, though smaller, is always nearly constant for the same input signal. For example, if the amplifier weakens with age, and the output tries to drop, there is less signal to be fed back; hence there is less cancellation, and the output is restored

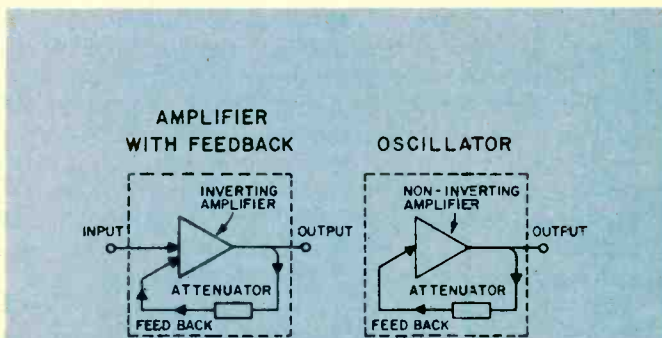

Fig. 1. Two block diagrams compare an inverting amplifier (A) to an oscillator (B).

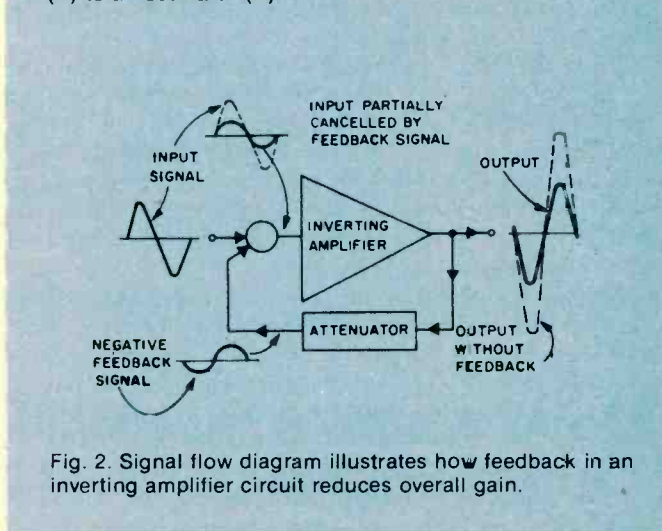

Fig. 2. Signal flow diagram illustrates how feedback in an inverting amplifier circuit reduces overall gain.

almost to its former level. Similarly, if you feed a high-frequency signal through the amplifier—so high in frequency that the amplifier can barely amplify it—the resultant drop in output reduces the feedback voltage, produces almost no cancelling feedback signal, and keeps the output nearly the same as it was at lower frequencies. Moreover, any clipping or other distortion of the waveform inside the amplifier produces an output waveform which does not match the input; hence the non-matching part is not cancelled, and the distortion is removed, or at least greatly reduced. Without this action, hi-fi amplifiers would not exist.

So the loss in output you obtain from negative feedback repays you by providing less distortion, better long-term stability, and better frequency response—that is, the best and most uniform output in response to *all* input frequencies.

On the Flip Side. The oscillator, on the other hand, is not supposed to give the best output from all input frequencies, but is instead made to give an output at a *single* frequency—with no input at all. It's not surprising that the opposite type of internal amplifier (non-inverting) is used to obtain this opposite result. See Fig. 3.

In the oscillator, any output at all (probably the result of some random noise in the internal amplifying device) is fed back, non-inverted, to the input, where it does not cancel but instead serves as the signal at the input. This feedback signal causes an even larger output, which results in an even larger signal fed back, further reinforcing the input signal, and so on.

You guessed it—this type of feedback signal is commonly referred to as *positive feedback*. In theory, the output waveform should continue to get larger forever. In practice, the amplifier is limited in the maximum size of the signal it can deliver, so the output waveform stops growing in this amplitude. As it stops to grow, so does the positive feedback signal. Now the signal reduces rapidly and the positive feedback signal lends a hand until the signal can get no lower. This is the beginning of the first cycle of many to follow.

All well and good, you say, but if the major difference between feedback amplifiers and oscillators is the inverting or non-inverting nature of their internal amplifiers, why does an amplifier sometimes oscillate? What turns an inverting amplifier into a non-inverting one?

To answer this question, first observe that an inverting amplifier, in passing a sine-wave signal, *effectively* shifts the signal's phase by 180° as shown in Fig. 4. We say *effectively*, because it doesn't really shift the timing by delaying the signal (which is what a real phase-shifter does) but, by turning the signal upside down, the amplifier makes it look like a signal which has been delayed (phase-shifted) by 180° .

A real phase-shifter, on the other hand, is normally nothing but a fistful of judiciously connected resistors and capacitors (and sometimes inductors) which can be designed to give a 180° phase shift at a *single* frequency, such as 1,000 Hz, for example. In contrast to an inverting amplifier, it provides this phase shift by actually delaying the signal. See Fig. 5.

What happens if we combine an inverting amplifier and a 180° phase-shifter? Take a look at Fig. 6.

This combination will shift the phase of a given frequency by a total of 360° (an entire cycle) so the output is identical to the input. In effect, this combination (at 1,000 Hz) *will behave the same as a non-inverting amplifier*. See Fig. 6.

Therefore, if we build a feedback amplifier which contains the normal inverting amplifier but also (inadvertently) contains a 180° phase-shift network, the resultant circuit will oscillate at the particular frequency, (1,000 Hz in the figure) for which the phase-shifter provides 180° phase shift. See Fig. 7.

How can one "inadvertently" make a phase-shifter? It's easier than you might think. The circuit shown in Fig. 8A will provide 60° phase shift at 1,000 Hz. Three such networks connected in a "ladder" (see Fig. 8B) will provide $3 \times 60^\circ = 180^\circ$ of phase shift. (But not at 1,000 Hz. Because of the way the networks load each other, the 180° shift occurs at 707 Hz. However, if an amplifier were located between each network, then the amplifier will oscillate at 1,000 Hz.) This network, if dropped into a normal feedback amplifier circuit, will convert it to an oscillator.

This circuit (Fig. 9) is known as a *phase-shift oscillator* and is widely used in electronics.

Of course, when you set out to build a phase-shift oscillator, you *deliberately* insert a phase-shifter to make the circuit oscillate. How could one ever *inadvertently* place such a circuit in a feedback amplifier, thereby producing unwanted oscillations?

Phase-shift circuits can "hide" within an amplifier, posing as other circuits. For example, vacuum-type amplifiers often have grid circuits arranged as shown in Fig. 10A. Does that resistor/capacitor circuit look familiar? In form, it's just like the phase-shift circuit above. And transistor amplifier circuits often take the

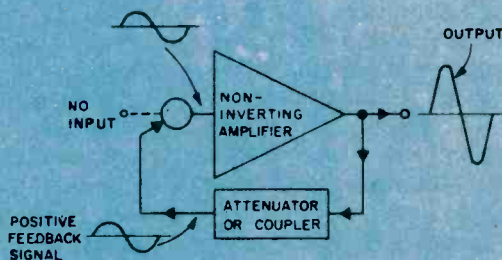

Fig. 3. Signal flow diagram shows how feedback signal from a non-inverting amplifier provides the positive feedback to produce an output signal larger than it would otherwise be without feedback.

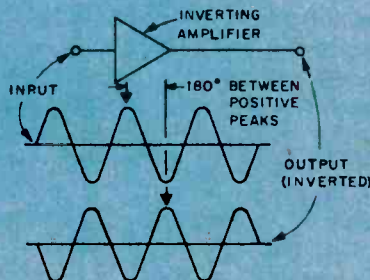

Fig. 4. The apparent phase shift of the output signal from the input signal is 180 degrees.

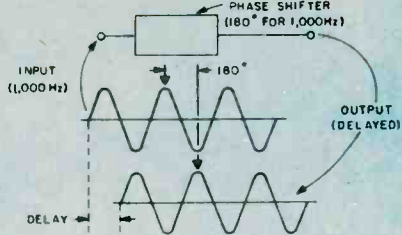

Fig. 5. The passive phase-shift circuit actually delays the output signal by a time interval measured in degrees by that portion of a sine wave so delayed. This effect appears to the apparent delay of an inverting amplifier.

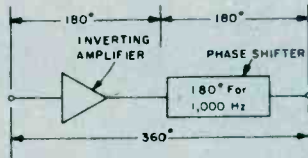

Fig. 6. Combining an inverting amplifier and 180-degree phase-shift circuit results in a 360-degree phase shift at 1000 Hertz only, which results in a non-inverting amplifier circuit.

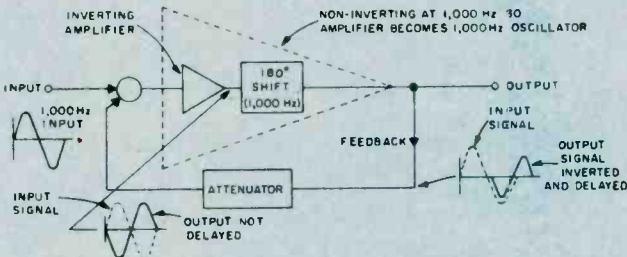

Fig. 7. Since the 180-degree phase shift is frequency selective, this non-inverting amplifier will oscillate at 1000 Hertz.

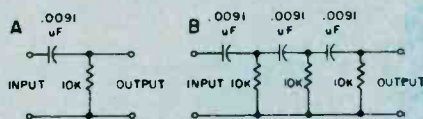

Fig. 8. In this diagram, a simple network (A) offers 60-degrees of phase shift at 1000 Hertz. Ladder three such circuits in series and the total phase shift at 1000 Hertz will be 180 degrees.

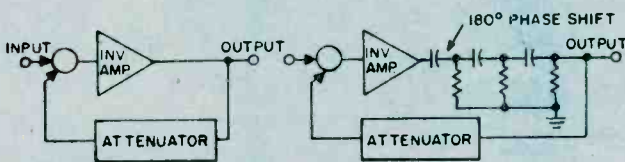

Fig. 9. Two inverter amplifiers are shown here with one having a 180-degree phase-shift network added to induce positive feedback. The RC elements limit this oscillation to be a fixed frequency.

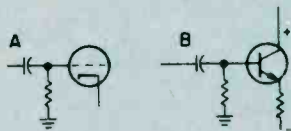

Fig. 10. External parts in this amplifier circuit have the same effect as the phase-shift circuit in Fig. 8A. However, values for the resistance and capacitance are selected to produce almost no phase-shift within the amplifiers normal frequency bandpass.

form shown in Fig. 10B.

Again, the coupling/biasing network looks just like the basic phase-shifter network. At some frequency, this network will provide 60° of phase shift. If we use three such identical networks in a three-stage amplifier we have a 180° phase-shift network "buried" inside the amplifier, masquerading as three normal coupling networks. If this three-stage amplifier is used as part of a feedback amplifier arrangement, the amplifier will oscillate at some frequency, and be quite useless for the purpose for which it was intended.

More Trouble. This is not the only way an amplifier can get into trouble. There are other types of phase-shifters that can creep into amplifiers, unrecognized, and drive the unwary experimenter up the nearest wall. This circuit (shown in Fig. 11A) can also produce a phase-shift of 60° at 1,000 Hz. Three of them, can produce the 180° phase-shift required for oscillation. See Fig. 11B. This particular network can invade amplifiers in an even more insidious fashion. The "masquerading" part of the circuit is shown heavy in Fig 11C. The dotted capacitor doesn't appear physically in the circuit, because it is the so-called "stray capacity" associated with wires, sockets, terminals, etc. Three of these circuits hiding in an amplifier, can produce an unwanted oscillation. See Fig. 12. Since the stray capacities are so small, this "oscillator" will oscillate at a very high frequency; often so high that it is undetected as an oscillation. However, such oscillation can make an amplifier behave erratically; sometimes distorting, sometimes not; sometimes overheating, sometimes not. Fig. 7 and Fig. 12 have a lot in common.

Are feedback amplifiers the only culprits in this oscillating-amplifier business? Absolutely not! Often, so-called "straight" amplifiers—with no *intentional* feedback—will gaily oscillate away. But watch that word *intentional*. Close inspection of these misbehaving circuits usually uncovers an *unintentional* feedback path hiding within the amplifier. Consider the innocent-looking circuit in Fig. 13. This is an ordinary two-stage amplifier, obviously assigned the task of converting a small, positive-going signal into a large, positive-going signal. To help it along, the designer has even provided a decoupling network, R1 and C1. At high frequencies, C1 acts like a short circuit, effectively isolating (decoupling) the amplifier's power bus, Ecc +, from the main power bus, Ecc + +. But, at low frequencies, the capacitor acts like an open circuit—it just isn't there! A small part of the output voltage now appears across R1, and is coupled through the amplifier's power bus back to the input, arriving there with the same polarity as the normal input. True, the signal unintentionally fed back isn't very large, because the unintentional feedback path provides substantial losses for this stray signal. For example, the signal may arrive back at the input 100 times smaller than it was at the output. However, if the amplifier has a gain of 101, it makes an even larger output signal out of the fed-back signal, which then is fed back as an even larger voltage and oscillation begins.

Careless construction can get you into trouble, too. The amplifier shown in Fig. 14 is trying to convert a 10-millivolt input into a 200-ma signal needed by the load, R2. The builder has tied all ground returns to a heavy

ground bus, and returned this bus to ground at only one point. Unfortunately, that single ground wire has to carry both the tiny input signal and the large output current. And, since every wire has *some* resistance, the actual circuit includes an 0.06-ohm resistor that does not appear in the original construction schematic diagram, but must be considered and is shown in Fig. 14.

Again, an uninvited, unintended feedback path has appeared, coupling the output back to the input. In the sketch, the large output current, flowing through the tiny ground-lead resistance, produces a voltage which is even larger than the original input voltage. And, since this voltage is also connected to the input (through the bias resistor R3), the fed-back voltage appears uninverted (and uninvited!) at the input, and will cause the amplifier to oscillate. What is to be done to convert these oscillators back into well-behaved amplifiers?

The general rule is *divide and conquer*. In the example just above, we can conquer the oscillation by dividing the ground returns, making sure that the high-current output circuits and the sensitive input circuits have their own private and individual paths to the power supply. See Fig. 15.

Short leads to the input connector are also helpful in squashing oscillations.

The misbehaving decoupling network, R1 and C2 in Fig. 13, can also be brought under control by dividing the network into *two* decoupling networks as shown in Fig. 16.

The stray capacities causing the unwelcome phase shifter to hide in the best divide-and-conquer approach to this amplifier are harder to exorcise. Your amplifier is to put feedback around only a pair of stages instead of three or more. This way, there are only two pairs of stray Rs and Cs lurking in the amplifier, and it takes at least three such pairs to make an oscillator.

The coupling capacitors, which combined to make a phase shifter in the very first example, can be prevented from ganging up on the amplifier and making it oscillate by making the product of each capacitor times its associated resistor (called the "RC product") 5 or 10 times larger or smaller than the other RC products. For example, in a three-stage feedback amplifier which has all its base resistors the same values, you could make the three coupling capacitors 2 μF , and 10 μF , and 60 μF , respectively. Again, you have divided the coupling capacitors into three widely-separated values, and conquered the oscillation. ■

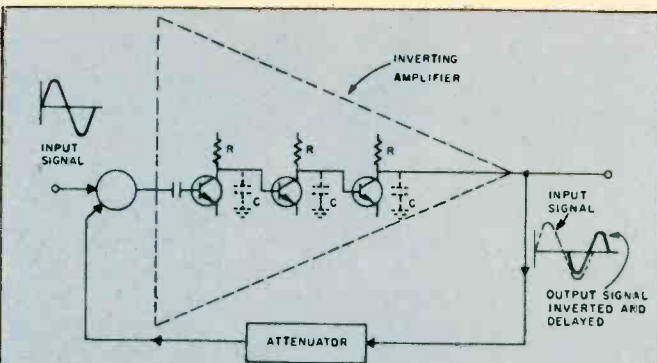

Fig. 12. An inverting amplifier may oscillate due to stray capacitance in these external circuit amplifiers providing a 180-degree phase shift at some very high frequency. Output signal is within frequency bandpass of the amplifier before phase shift causes oscillation (positive feedback).

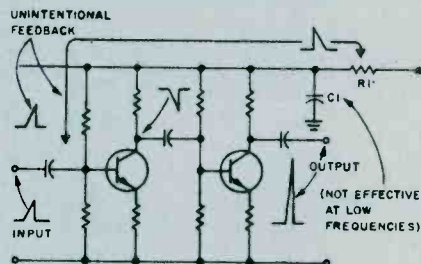

Fig. 13. Low frequency feedback occurs because the capacitor C1 is not effective at these low frequencies. Thus, any portion of the output signal that will cause a ripple in the power supply will serve as a positive feedback.

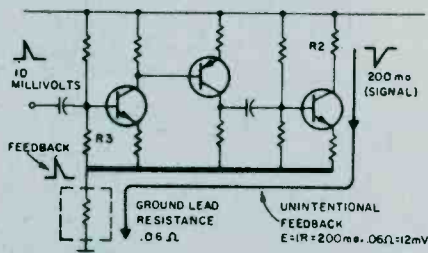

Fig. 14. A ground bus has a finite resistance, and, when high-current output signals mix with low-level signals in the same bus, positive feedback may result with the attending possibility of oscillation.

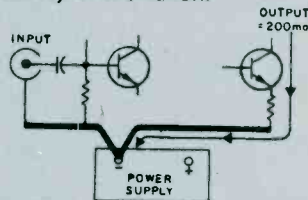

Fig. 15. Divide and conquer—separate input connections from output connections to different buses, and a good deal of the unwanted signal mixing will not occur. The resistance of the power supply must be very low otherwise all that is gained using this construction technique will be lost.

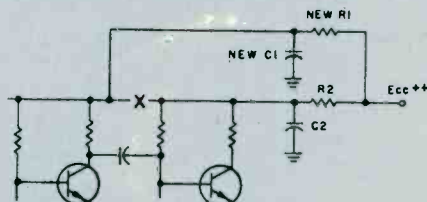

Fig. 16. A good idea is to split up the voltage distribution to many circuit points by two or more power supply decoupling networks. Compare this diagram to Fig. 13.

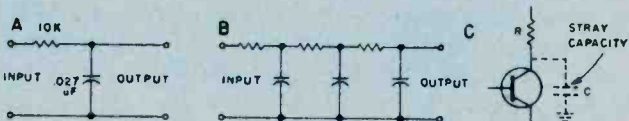

Fig. 11. Don't get confused with the circuit elements shown in (A) with those shown in Fig. 8A. The reversal of parts converts the basic circuit from a coupler to a filter with the attending phase shift. Three series-connected filters have the same effect (B) by providing 180-degree phase shift. Hidden capacitance (C) internal to the circuit element and in the external wiring will provide some phase shift of the output signal in this amplifier.

AM/FM RECEIVER ALIGNMENT

The words "receiver alignment" often conjure up a mysterious and complicated procedure which can be performed only by an expert. While it is true that receiver alignment should not be attempted by anyone who does not have the necessary skills and equipment, it is not a very difficult procedure if you have some basic guidelines. This article will explain the various procedures for aligning AM, FM, and AM/FM receivers using a minimum of equipment.

Before getting into the mechanics of receiver alignment, it is important that the service technicians understand the basic operation of the receiver, and why proper alignment is necessary. To this end, a discussion of the modern superheterodyne receiver will follow.

Receiver Fundamentals. Virtually every AM and FM receiver manufactured today is a superheterodyne receiver. They utilize a built-in RF oscillator and mixer circuit to convert the received signal to a lower

frequency called an intermediate frequency (IF). In a given AM or FM receiver, the IF remains the same frequency regardless of which radio station is being received.

The basic advantage of this type of circuit is that the greatest part of the RF gain, and bandpass characteristic of the receiver, is provided by the IF stages, and is a constant for all received frequencies. Thus, the manufacturer of the receiver can precisely determine the sensitivity and selectivity of the receiver. Proper alignment ensures that the receiver performs exactly the way the manufacturer intended. Refer to Fig. 1, which is a simplified schematic diagram of the RF and IF sections of a typical modern day AM receiver.

In Fig. 1., simplified AM radio schematic, you will note a combination mixer-oscillator stage, and two stages of IF amplification. This circuit is typical of a minimum cost AM receiver which has a two gang tuning

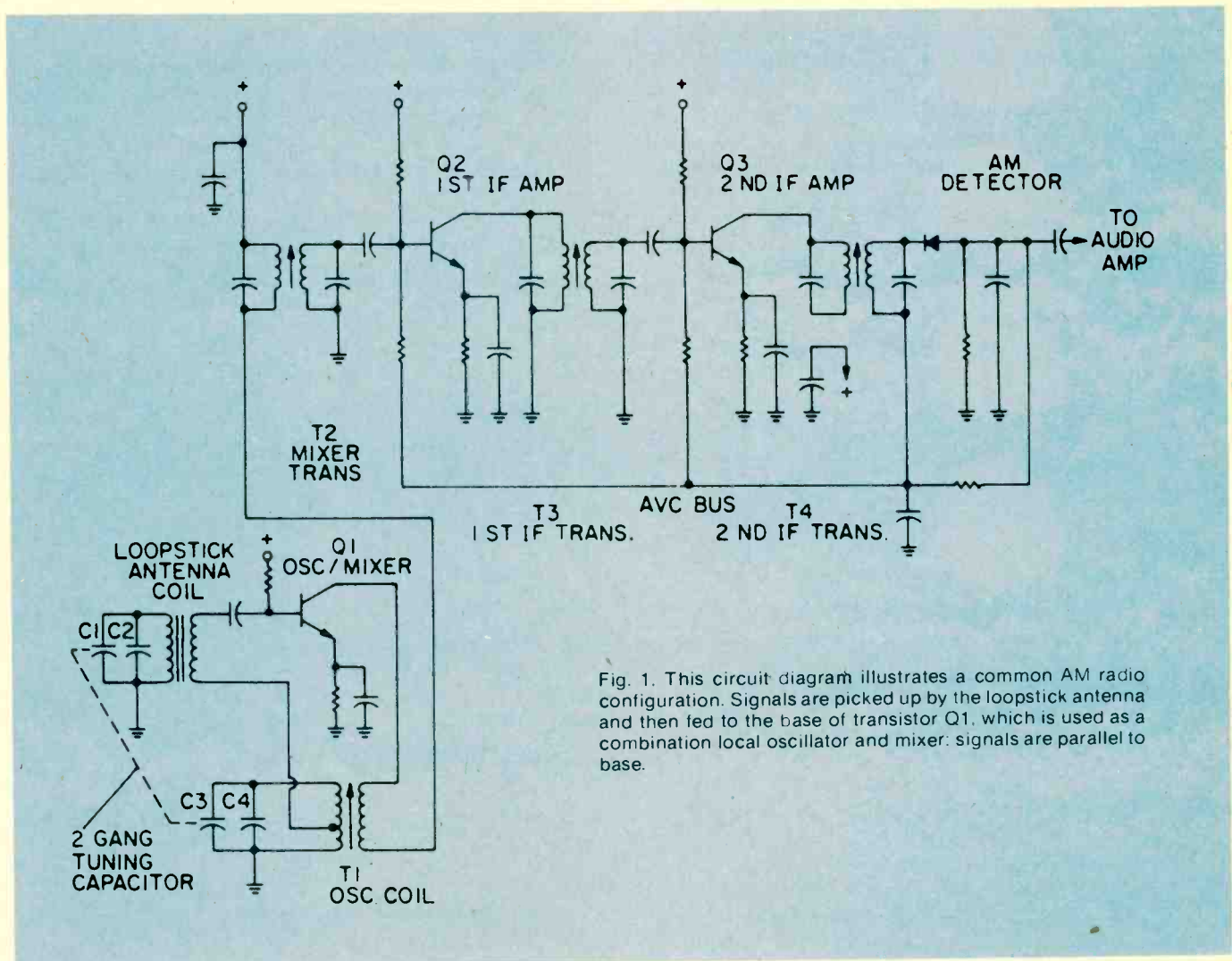

Fig. 1. This circuit diagram illustrates a common AM radio configuration. Signals are picked up by the loopstick antenna and then fed to the base of transistor Q1, which is used as a combination local oscillator and mixer: signals are parallel to base.

capacitor and no FR amplifier. Such a circuit might be used in a common pocket-sized AM transistor radio. More expensive receivers will use a similar circuit with the addition of a transistor stage for RF amplification.

In the circuit of Fig. 1, the received signals is picked up by the loopstick antenna and is fed to the base of Q1. This transistor stage is used as a combination local oscillator and mixer, and is actually a Hartly oscillator with the received signal being placed in series with the base drive of the oscillator. The frequency of oscillation is determined by C3, C4 and T1. At the same time C1, C2 and the loopstick antenna are tuned to the received signal frequency. The output of T2 contains several frequencies: the radio station frequency, the local oscillator frequency and two new frequencies equal to the sum and difference of the local oscillator and received frequency.

It is the function of the two IF stages, Q2 and Q3, to amplify the difference frequency (IF) and reject all others. This is accomplished by tuning all IF transformers, T2, T3, and T4, to the specified frequency. For most AM receivers, this is 455 KHz. The tuning of these transformers is performed during alignment of the receiver.

FM Circuitry. Fig. 2, is a simplified schematic of a typical FM receiver. In this diagram you will note the similarity with the AM receiver schematic of Fig. 1. This basic difference, aside from the higher operating frequency, is that the FM receiver employs an RF amplifier stage, Q1.

Most FM receivers have at least one RF amplifier, since it is the nature of FM transmission that weaker signals than AM are usually encountered. Good FM reception

requires a solid signal in the IF amplifier, so that effective limiting takes place. Note also the requirement of a three gang variable capacitor instead of the two gang as appears in Fig. 1. The additional cost and size of this capacitor is one reason why most AM receivers have no RF amplifier stage.

Although the IF amplifier stages of the AM receiver and FM receiver appear to be similar, there is a substantial difference in the way in which they are designed. The bandwidth of an AM radio station is just 10 KHz, and the receiver must be designed to have an IF bandwidth no greater than this. Such a narrow bandwidth is easily controlled by the design of the IF transformers which, when turned to the same frequency such as 455 KHz, will provide the desired bandwidth of 10 KHz.

In the case of FM reception, and especially Stereo Multiplex FM, good reception requires a receiver with at least 150 KHz bandwidth. It is the nature of FM to have significant sidebands on either side of the carrier frequency, as far away as 75 KHz. Such a wide bandwidth in the IF stages of an FM receiver cannot be attained by tuning each stage to the same frequency. What is done is to stagger tune each stage, so that the resultant overall response has the required bandwidth. Note that each IF transformer in Fig. 2 has separate tuning slugs for primary and secondary which permit stagger tuned alignment.

Because of the problem of attaining proper alignment in the IF stages of an FM receiver, the more expensive designs utilize special filter circuits which are tuned to the factory and require no adjustments in the field. You will find that many modern stereo receivers are designed

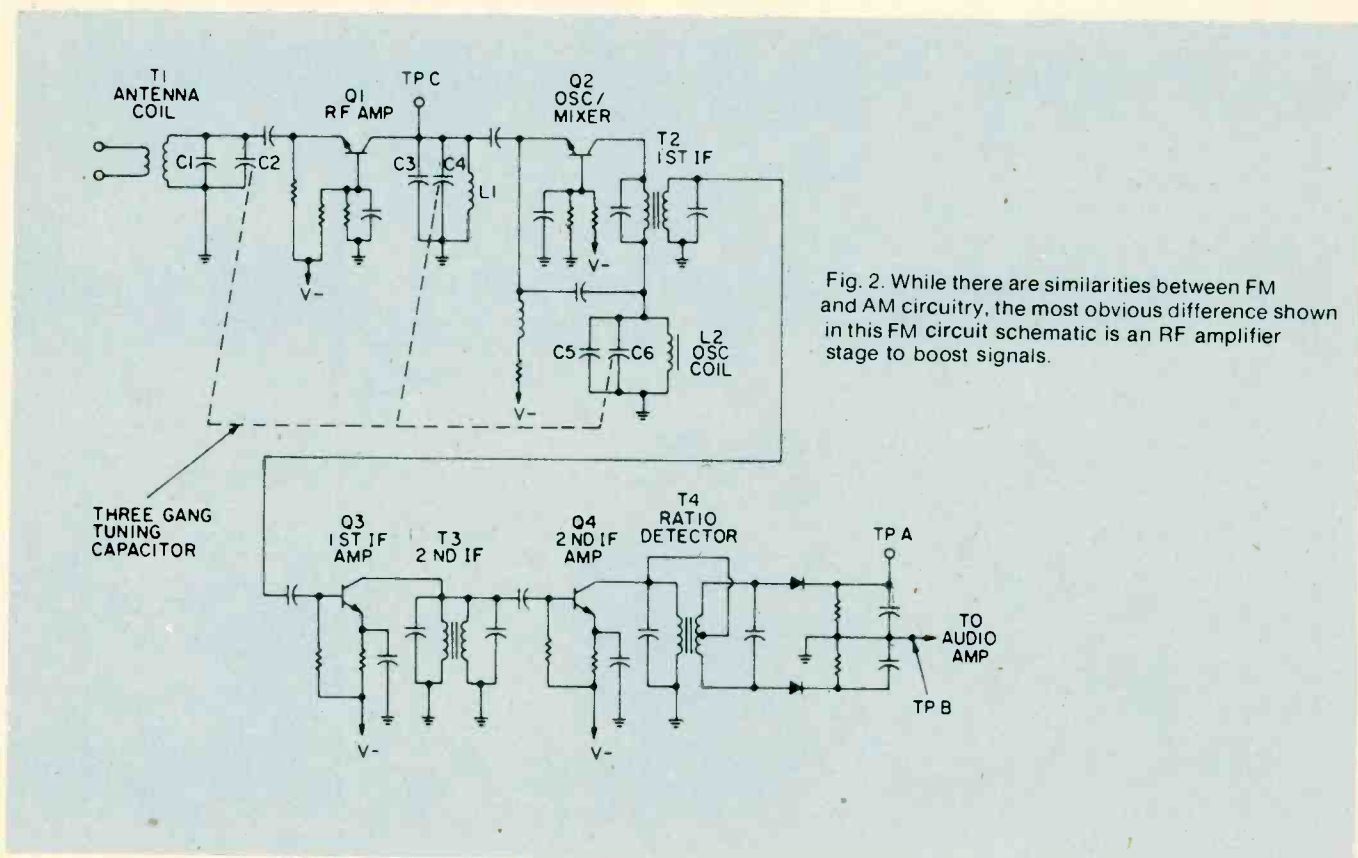

Fig. 2. While there are similarities between FM and AM circuitry, the most obvious difference shown in this FM circuit schematic is an RF amplifier stage to boost signals.

this way. However, these types of receivers still require alignment of the RF and local oscillator sections of the unit as you would expect.

AM Receiver Alignment. Alignment of an AM receiver is a relatively simple procedure, and can actually be performed by using existing radio stations as a signal source instead of a signal generator. However, if a signal generator is available, it is always best to use it as described in the following paragraphs.

When performing the alignment of an AM receiver, connect a few loops of wire across the output cable of the signal generator and loosely couple the loops to the AM antenna coil. Use the smallest RF output from the generator that will produce a reliable meter reading. For a tuning indicator you can connect a VTVM or VOM set to measure AC volts across the voice coil of the speaker.

An alternate method is to measure the DC voltage level on the AVA (Automatic Volume Control) line of the receiver. This requires a high impedance DC voltmeter such as a VTVM.

The alignment procedure will, of course, depend upon the number and type of adjustments in the specific

receiver under test. If possible, obtain the manufacturer's alignment procedure. In the absence of such information you can use the following procedure.

IF Alignment. The first adjustment to be performed is the IF alignment. Set the signal generator at 455 KHz. with about 30% to 90% amplitude modulation. Loosely couple the output of the generator to the antenna coil of the receiver and listen for the audio modulation in the receiver speaker as the RF generator is varied about 455 KHz. If you do not obtain any audio around this frequency, the IF of the receiver may be another frequency, such as 262 KHz.

Once you have determined the proper frequency, set the generator at 455 KHz. or whatever the specified intermediate frequency may be. Connect the VOM across the voice coil of the receiver and adjust the IF transformers (T2, T3, and T4 in Fig. 1) for the maximum reading of the meter.

As you progress with the IF alignment, you may find that you can lower the RF output of the signal generator to prevent overload of the receiver. When you are satisfied that all IF transformers are tuned so that no

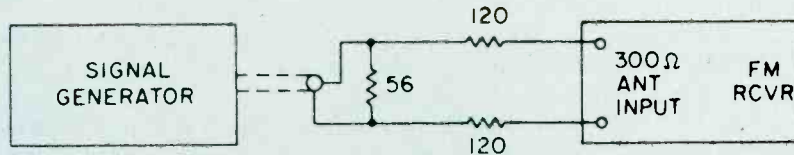

Fig. 3. A matching circuit must be used when attaching sweep generators to FM sets.

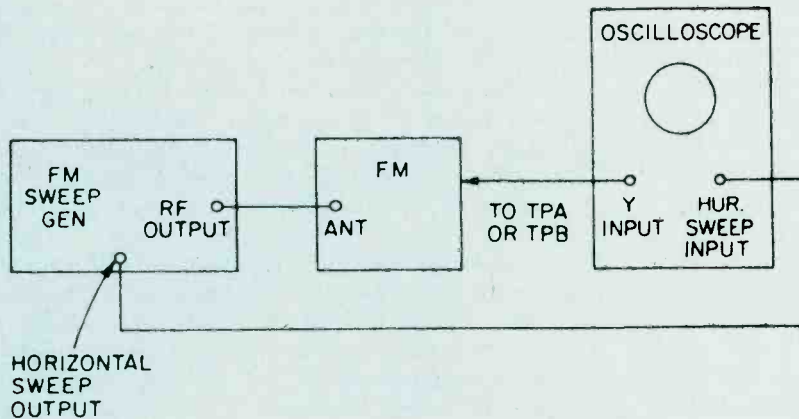

Fig. 4. When using both a sweep generator and oscilloscope for aligning an FM set, they must be connected in the manner shown in the diagram on the right side.

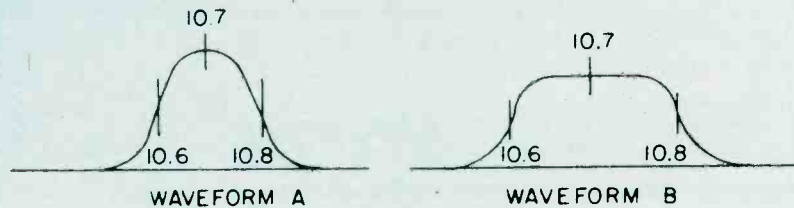

Fig. 5. The lower-quality FM receivers will have a waveform resembling A; while better sets will show something more like B.

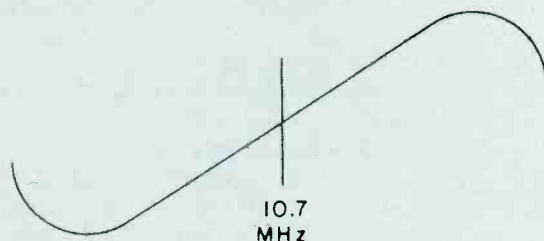

Fig. 6. Adjust the secondary of the discriminator transformer 'til it centers 10.7 MHz.

further increase in meter reading can be attained, the IF alignment is complete.

The next set of adjustments will align the upper and lower settings of the tuning capacitor. This is accomplished in two steps, which will have to be repeated several times, since the adjustments have some interaction with each other.

The initial adjustments are made at the high end of the broadcast band. Set the tuning dial to a silent point (where no radio station is received) near 1600 KHz. Set the RF signal generator to the same frequency. Adjust the two trimmer capacitors (C2 and C4 in Fig. 1) for maximum meter reading.

Then set the tuning dial of the receiver to a silent point around 600 KHz. and set the signal generator to the same frequency. Adjust the oscillator tuning coil (T1 in Fig. 1) for maximum meter reading.

Repeat the adjustments for 1600 KHz and 600 KHz as described above until no further improvement can be made. Once you have done this, the AM alignment will be completed.

FM Receiver Alignment. Proper FM alignment requires the use of a sweep generator and oscilloscope, unless the receiver under test has a fixed tuned IF section which is permanently aligned at the factory. The generator may be coupled to the antenna terminals of the receiver using the circuit of Fig. 3, which matches the 50-ohm impedance of the generator to the 300-ohm input impedance of the FM receiver.

Some receivers may have highly selective front ends which make injection of the 10.7 MHz IF through the RF stages difficult. In these receivers you may couple the output of the signal generator to the input of the first IF amplifier stage through a 10-pf capacitor. This point is shown in Fig. 2, as test point C. Use only sufficient signal strength to achieve a usable display on the oscilloscope. Fig. 4, is a typical connection diagram of the receiver, generator and oscilloscope.

The first section of the FM receiver to be aligned is the IF amplifier. Set the signal generator to a center frequency of 10.7 MHz. and a sweep width of about 450 KHz. An FM sweep generator should have a marker system which allows you to identify the important frequencies of interest, such as 10.6, 10.7, and 10.8 MHz. These markers indicate the desired bandwidth of the IF amplifier.

Connect the Y input of the oscilloscope to test point A of Fig. 2, and adjust the scope controls to obtain a display

similar to Fig. 5. Adjust all IF transformers (T2, T3, & T4 in Fig. 2) so that the amplitude of the display is maximum, while preserving the symmetry of the waveshape at about 10.7 MHz. Bear in mind that low cost FM receivers will have a waveshape similar to that of waveform A, while high quality receivers will have the preferred waveshape B of Fig. 5.

The next step is the adjustment of the Ratio Detector or Discriminator. Connect the Y input of the oscilloscope to test point B of Fig. 2, and adjust the secondary of the Ratio Detector or Discriminator transformer (T4 of Fig. 2) to place the 10.7 MHz marker at the center of the S curve, as shown in Fig. 6. Readjust the primary of the same transformer for maximum amplitude and straightness of the line between the positive and negative peaks. This completes the alignment of the IF section of the receiver.

Trimmer Adjustments. The final adjustments to the FM receiver are made to the trimmer capacitors, which are connected in parallel with the main FM variable capacitors. These are shown in Fig. 2 as C1, C3 and C5. Note that some FM receivers, especially the higher quality ones, may have four such trimmer capacitors. These adjustments are made with the FM tuning dial set to near the high end of the range, (108 MHz).

Set the FM dial to a silent point near 108 MHz. Set the signal generator to the same frequency as the dial setting, and couple the output of the generator to the antenna terminals of the receiver as shown in Fig. 3. Connect a DC voltmeter to test point A as shown in Fig. 2, and use only enough signal output from the generator to attain a reliable meter reading. Adjust C1, C3, and C5 as shown in Fig. 2, for maximum meter reading.

As a final check, set the receiver dial to a silent point near the low end of the range, 88 MHz, and set the generator frequency to the same frequency. Now, by varying the generator about 88 MHz while watching the DC voltmeter, you can determine how accurate the FM dial is.

Keep in mind that if you do make this adjustment you will have to go back to 108 MHz and readjust the trimmer capacitors again. In addition, if you are working on an AM/FM receiver slipping the dial pointer will also require a realignment of the RF section of the AM receiver. For these reasons it is not recommended that the dial be slipped unless it already has been placed far out of calibration through some previous servicing procedure. ■

SIGNAL PROPAGATION

The propagation of all radio waves may be defined as: "The traveling of wave energy through the atmosphere." How do signals get from one side of the world to the other? The ionosphere, a region of the earth's atmosphere extending upwards from 50 to 350 miles (80-560 kilometers), has ionized layers with the ability to reflect electromagnetic energy of certain frequencies.

The purpose of this article is to review, briefly, the components of the ionosphere, some propagation characteristics, and some ways that you can tell whether or not the amateur bands are in good condition for DX

communications.

The Ionosphere. In 1901, Marconi succeeded in transmitting radio signals from England to America, over the bulge of the earth. Since it was known that electromagnetic waves travel in straight lines, Heaviside and Kennelly proposed in 1902 that the radio waves had been reflected from an atmospheric layer consisting of free electric charges. Heaviside called it the "electrified layer", and others called it the "Heaviside layer." Later, Appleton discovered between the two layers, and to make room for other possible layers, he called the

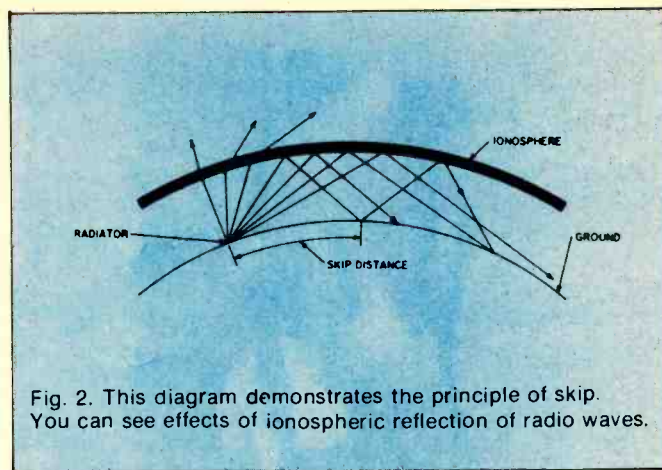
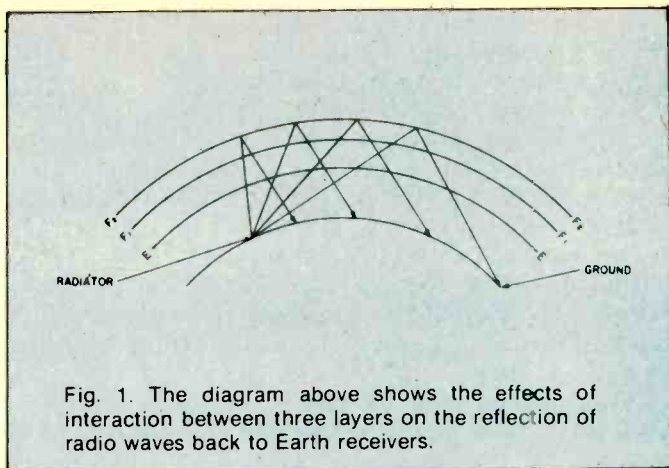

Heaviside layer the E layer, and the new layer the F layer. Subsequently a lower layer was discovered, called the D layer. It was also found that the F layer consisted of two layers which separated during the day and merged at night, and the concentration of electrons decreased in all layers at night.

The D-layer (50 miles or 80 km up) assembles during the day and disappears at night. It primarily affects 160 to 180 meters, limiting daytime coverage to groundwave by absorbing skywave signals.

The E-layer (75 to 120 km up) provides stable skywave coverage during the day on 10 through 40 meters, and on 80 to 160 at night. The nominal skip distance is around 1,000 miles (1,600 km), but double hops can and do occur. During primarily the summer months, sporadic-E—extra-thick patchy clouds of ionization—opens 6 and 10 meters for short duration openings during the day or night.

The F-layer at night is about 200 miles (320 km) high, and during the day, it separates into the F₁-layer (125 miles or 200 km up), and the F₂-layer (250 miles or 400 km up). These layers are the mainstays of the DX'ers looking for worldwide coverage. A single hop covers 2,000 to 3,000 miles (3,200-4,000 km), and multiple hops cover up to 12,000 miles (19,300 km). What gets reflected by the F₁ and the F₂-layer depends upon the degree of ionization and the angle of the arriving signal at the ion layer.

The Maximum Useable Frequency. The maximum useable frequency (MUF) is simply defined as the highest frequency that can be used over a particular transmission path.

The MUF is affected by three variables: the 11-year sunspot cycle, the annual cycle, and the daily cycle.

Mid-1980 is generally predicted as the next peak in the sunspot cycle. Although the upcoming peak is not expected to equal the all-time historical cycle centering on 1958 when the MUF cleared 100 MHz on many occasions, 10 and 15 meters should be superlative.

The annual cycle varies from summer to winter. Due to the amount of solar radiation received by the several ion layers, the MUF is lower during the winter than summer (although atmospheric noise during the summer may hide those benefits). The overall height of the F₂-layer during the winter day is lower too, by some 200 miles (320 km) than during the summer day. The F₁-layer is also lowered somewhat. The effect is that more hops

are required to cover the same distance, thus introducing more variables into the degradation of the signal over the transmission path. Winter or summer, the height of the nighttime F layer remains about the same.

The daily cycle is the most variable. The MUF is higher during the day than at night. During the short winter day, the "day" effect may seem brief. The twilight hours of DX'ing during the winter may be longer, and very interesting.

Twilight DX'ing. The rate of change of ionization is greatest at sunrise and sunset. (Listen to the broadcast band (540-1600 KhZ) for a vivid example of this.)

80 and 40 meters provide very interesting DX'ing conditions worldwide during the twilight hours. The specialty of greyline DX'ing, sending signals around the world following the day-night demarcation, is a science in itself. The key is in timing, knowing when both ends of the path will be in twilight. Take a look at *80 Meter DX'ing*, by ON4UN, John Devoldere (from the Ham Radio Publishing Group, Greenville, NH 03048), for a further discussion of this type of DX'ing.

On the higher bands, DX'ing the twilight hours, by pointing your antenna into the daylight, can maximize the coverage of your signal. In the daylight, the ionization at the reflection points of the transmission path are near maximum, and any D-layer absorption is rapidly disappearing.

Band Conditions. Aside from the three-fold variables affecting the MUF, there are other short-term, solar-induced factors that affect propagation.

Sunspots, storms on the surface of the sun, can affect conditions by several types of radiation. Sudden ionospheric disturbances (SIDs) caused by solar flares can cause instant blackouts of worldwide radio communications on the earth.

Other, less severe, disturbances caused by intense radiation from the sunspot (or group of sunspots) tend to be longer lasting. As the radiation is sprayed outwards (just like pointing a garden hose away from you and turning quickly in a circle), sweeping across the earth, the effects on the earth may last from four to five days at a time. The sun rotates on an average 27 period, and the long-lived sunspot eruptions may have a recurring effect on the earth approximately 27 days, and multiples thereafter, until the particular sunspot (s) disappears.

The Auroral Zones. The magnetic poles of the earth draw most of the particles toward the north and south

polar regions. These auroral zones are centered roughly 23 degrees from the magnetic poles.

The size of the auroral zones changes with the intensity of the solar radiation. Flares and sunspots will increase the geomagnetic activity in the polar regions.

Signals traversing the auroral zones will have a characteristic polar flutter induced on them. If the geomagnetic storm is severe enough, signals will be absorbed.

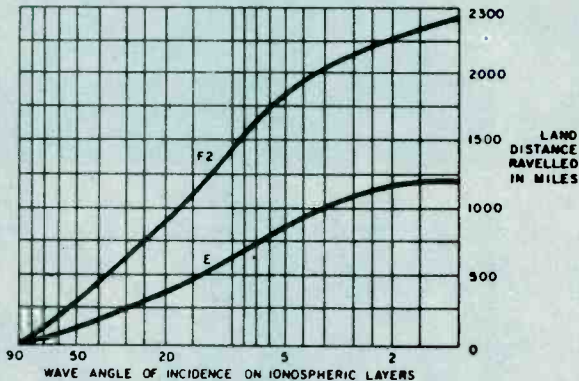

Fig. 3. The graph above shows the relationship between the angle of incidence of radio waves striking the "E" and "F2" layers of the ionosphere and the distance which they will travel over land. Obviously, the lower the angle, the greater the distance travelled by the waves.

As signals travel a Great Circle path, the high latitude paths will be the first to disappear as these reflection points are absorbed. As the storm continues, the lower latitude signal paths will disappear into the noise and, eventually, only signals from the south (in the northern hemisphere) will be heard. Those reflections points are outside the enlarged zone.

Sources of Information. How do you know if band conditions are good enough to warrant your time and effort to chase some DX? One time-consuming way is to tune across the bands, stopping at each signal encountered to see who it is.

An alternate method is to do some homework. A number of the amateur magazines offer long-range forecasts which are based upon extrapolations of current data. The newsletters offer more up-to-date forecasts, projecting just a week or two into the future.

Such newsletters include: the weekly *hr report* (Greenville, NH 03048), the weekly *West Coast DX Bulletin* (77 Coleman Drive, San Rafael, CA 94901), the bi-weekly *Long Island DX Association Bulletin* (Box 173, Huntington, NY 11743), and the bi-weekly *Mail-A-Prop* (11307 Clara St., Silver Spring, MD 20902). Except for *hr report*, send a #10 SASE for subscription information.

A telephone call to Dial-A-Prop (516-883-6223) will deliver a message tape 24 hours a day, seven days a week. Tapes are normally updated on Tuesdays.

Also, WIAW runs a weekly propagation bulletin amongst its daily airing of news and OSCAR bulletins. Check a recent copy of *QST* for the schedule, or ask the ARRL (Newington, CT 06111) for a WIAW schedule (send as SASE).

The most timely information is provided by WWV. Unlike the other sources cited above, the National Bureau of Standard's propagation information is oriented for the engineer and scientist, and not for just the radio amateur.

WWV's Propagation Bulletin. At 18 minutes past each hour, WWV (on 2.5, 5, 10 and 15 MHz) broadcasts a tape supplied by the National Oceanic and Atmospheric Administration's Environmental Research Laboratories.

The message contains number counts of the solar flux, the A-index, and the K-index.

The solar flux is a measure of solar radiation: units range from 60 to 400. The higher the flux, the higher the MUF. In late 1978, the flux was averaging 160.

The A-index is a measure of geomagnetic activity ranging from 0 (extremely quiet) to 400 (very disturbed) units. An A-index of more than 20 usually wipes out polar path signals. Only on a very few occasions in the past five years have I seen this index exceed 100.

The K-index is mathematically related to the A-index and is a measure of geomagnetic activity. Its range is 0-9.

As the flux and A-index counts are updated daily at 0000 GMT, and the K-index is updated every six hours at 0000, 0600, 1200, and 1800 GMT, it is possible to track short-run variations from day-to-day and from six-hour period to six-hour period.

In practical terms, you can build a set of references for yourself by noting the WWV counts under normal and abnormal conditions. The set of references may differ for different operators. The better the equipment and the antennas, the longer you have to work DX under worsening or marginal conditions.

Conclusion. I have only touched on some the principles and highlights of propagations and determining band conditions. One of the better books for those seeking further readings is a classic by Stanley Leinwoll, *Shortwave Propagation*, published by John F. Rider Publishers, New York, 1959. It would be worth hunting for on library shelves. For a detailed explanation of the H+18 WWV bulletin, pick up a copy of *Introduction to Solarterrestrial Phenomena and the Space Environment Services Center* Stephen J. Mangis, NOAA Technical Report ERL 315-SEL 32, put out by the U.S. Government Printing Office, Washington, 1975.

Amateur band DX'ing doesn't *have* to be hit or miss. Do a little reading and a little studying, and watch your DX totals go up. ■

THE UART

No, UART does not mean United Authority for Radio Tubes! It stands for *Universal Asynchronous Receiver Transmitter*. The UART is a special LSI integrated

circuit that allows us to make a serial communications or I/O port for our microcomputers. With a single UART chip and a few other devices mounted on a blank S-100

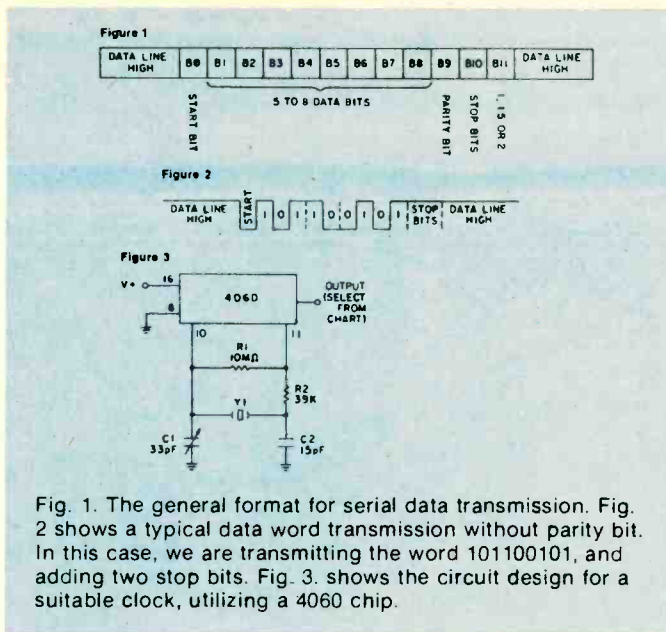

Fig. 1. The general format for serial data transmission. Fig. 2 shows a typical data word transmission without parity bit. In this case, we are transmitting the word 101100101, and adding two stop bits. Fig. 3. shows the circuit design for a suitable clock, utilizing a 4060 chip.

prototyping card (such as the Vector® products), we can make a serial I/O port rather easily. So who is the designer of a serial I/O for *your* microcomputer? Well, with the UART, *thou* art!

Serial Data Transmission. Transmission of data from one unit to another might take place over a distance of a few feet, a few yards, several miles or across a continent. Except in the shortest runs, e.g., from one equipment cabinet to another, it is usually more economical to use *serial* data transmission, in which the bits of the word are sent over the communications channel one by one. If we wanted to use parallel transmission, which is a lot faster, it would require not less than one wire or radio or telephone channel for each bit transmitted—and that can be expensive! In serial transmission, only one channel is needed, so that it is the lowest cost way of accomplishing the job!

But microcomputers tend to have parallel organization. The eight-bit data bus is a parallel structure. Before we can transmit the data over a serial channel, therefore, we have to assemble the data in serial form. This was once a bit difficult, and required the interaction of both hardware and software, but today, we can make the job a lot easier because of the UART.

This LSI device will accept parallel format data on the transmitter inputs, send it out in serial form, and then reassemble it in parallel form on the receiver end. The typical UART contains both receiver and transmitter sections, so it may be used as either receiver, transmitter, or both.

The UART will also add certain bits needed in the parallel transmission. Figure 1 shows the general format for serial data transmission. The data line will sit HIGH (i.e. logical 1) when there is no transmission taking place. The data word transmission begins with a start bit, which is a LOW condition. The transmission equipment, and the receiver section of the UART, sees the HIGH-to-LOW transition of the start bit as the signal that the data word is beginning. Following the start bit, are five, six, seven or eight bits of the data word. The typical UART chip is programmable to permit any of these data word

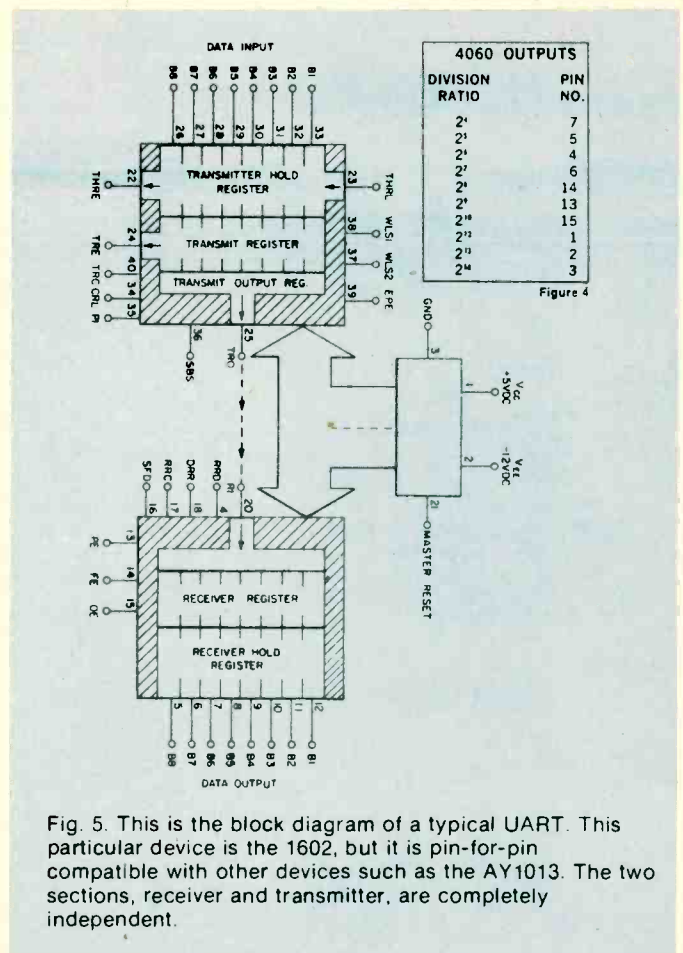

Fig. 5. This is the block diagram of a typical UART. This particular device is the 1602, but it is pin-for-pin compatible with other devices such as the AY1013. The two sections, receiver and transmitter, are completely independent.

bit lengths. The ninth bit could be a parity bit.

The concept of parity is used to check the data transmission for errors. The parity can be odd, or even, and this refers to the number of HIGH bits in the data word. The UART will set the parity bit HIGH or LOW to make the parity of the total word equal to that programmed into the system. Finally, there are 1, 1.5 or 2 stop bits. For most of our applications, we will use 2 stop bits, but some applications (like teletypewriters, for example) require 1.5 stop bits.

Figure 2 shows a typical data word transmission (without parity bit). In this case, we are transmitting the word 101100101, and adding two stop bits.

Clocking In. Data transmission means that the operations of the transmission are independent of a master system clock. But this does not mean that the clock must be accurate, and relatively stable. In general, RC-timed clocks are not acceptable, so we must use crystal control of the clock.

Figure 3 shows the circuit for a suitable clock, while Fig. 4 shows the pinouts for various division ratios of the internal counter of the 4060 chip used in the oscillator. The 4060 chip is a multistage binary counter that includes its own oscillator stage.

The 4020 device, incidentally, is similar, except that it does not have the oscillator. Crystal Y1 will have a frequency selected by the desired baud rate of the data transmission, and the division ratio selected. The clock frequency applied to the input of the UART must be 16 times greater than the desired baud rate. If, for example,

we want to drive a 300 baud printer from the UART, then clock frequency must be 16×300 , or 4800 Hz. If we select the 2^9 output of the 4060, the division ratio is 256, so the frequency of the oscillator should have a crystal

frequency of 256×4800 Hz, or, 1,228.8 kHz. A frequency of 1.229 MHz is a standard crystal frequency, so that could be used. Trimmer capacitor C1 could then be used to trim the frequency to exactly 1.2288 MHz.

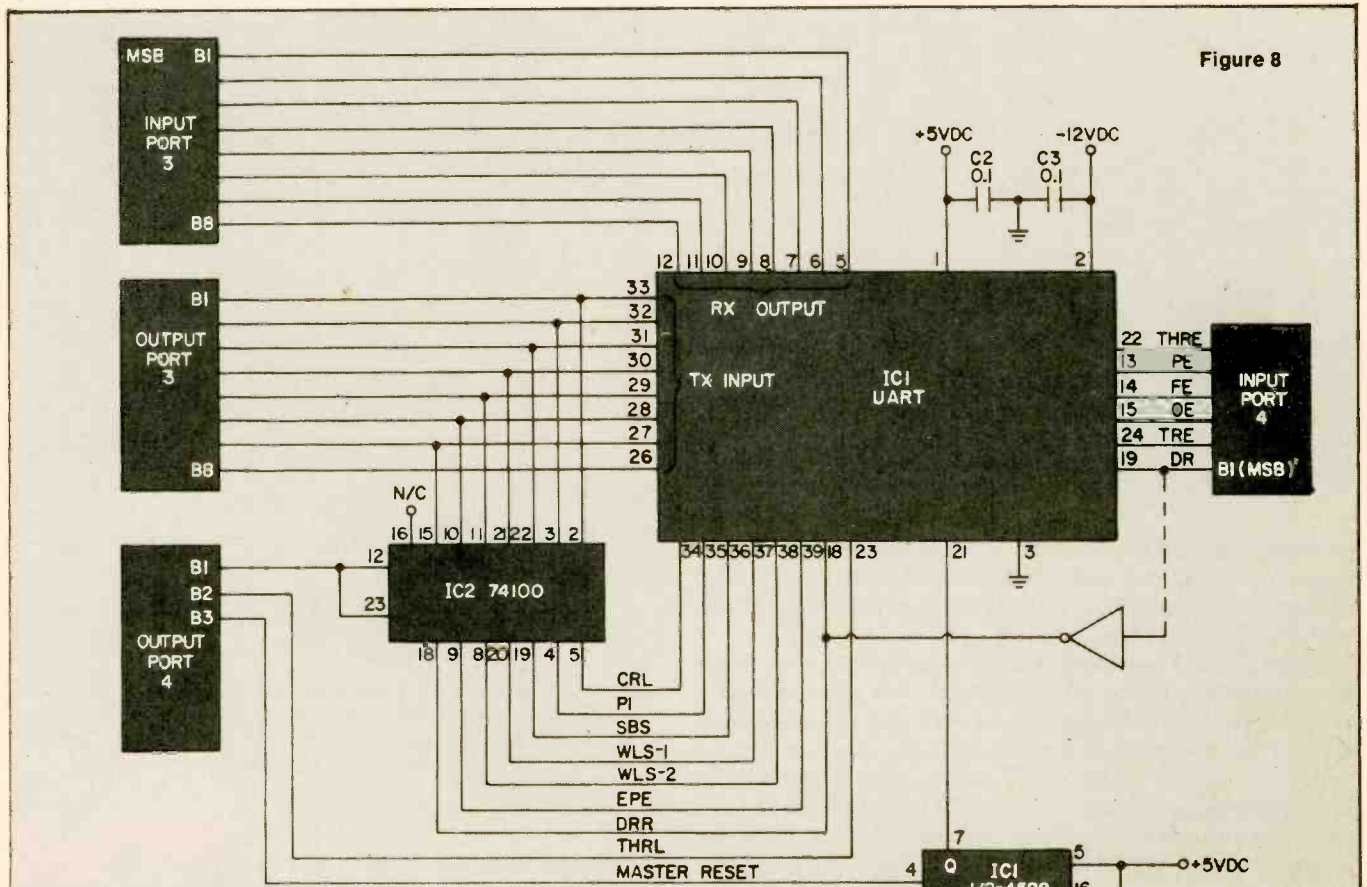
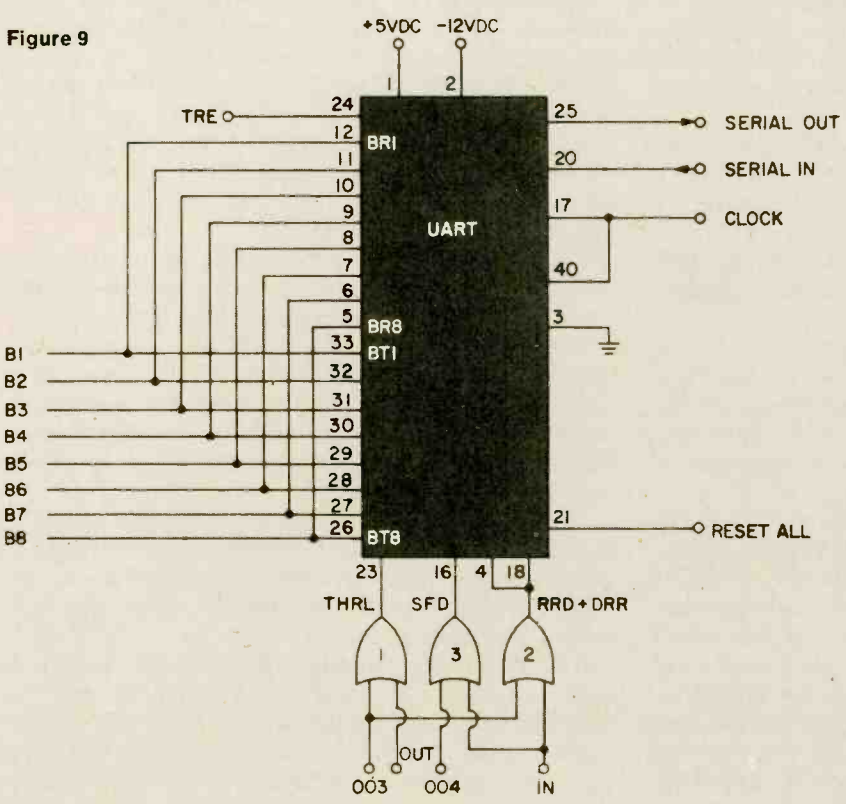

Figure 8

Figure 9



The transmitter section circuit of the UART is shown in Figure 6. The receiver section of UART is shown in Figure 7. The transmitter requires eight input bits, a clock at 16X the baud rate, and certain programming commands. The receiver obeys the control signals wired into the transmitter section. Figure 8 shows the connection of the UART to a data bus. All the outputs of the UART are tri-state. The methods shown in Figure 8 are basically for the 8080A device, but similar connections will allow use of the Z-80 and others. Figure 9 shows a method for connecting the UART to I/O ports of an existing microcomputer device.

The **UART**. Figure 5 shows the block diagram of a typical UART. This particular device is the 1602, but it is pin-for-pin compatible with devices such as the AY1013 and others. The two sections, receiver and transmitter, are completely independent except for the common connection to the power supply and control section. We can use either the receiver, the transmitter, or both sections at once.

The transmitter section contains an eight-bit *transmitter hold register*, and a *transmitter register*. The hold register is a buffer, or storage area. When the THRL (transmitter hold register load) control line is brought LOW data on the eight input lines is loaded into register. This data is transferred into the transmitter register for assembling into serial format and then for transmission.

The transmitter section also has certain other control lines, including the following: THRL, WLS1, WLS2, EPE, THRE, TRE, TRC, CRL and PI. These are defined as follows:

THRL	Transmit Hold Register Load
WLS1,2	Word Length Select
EPE	Even Parity Enable
THRE	Transmit Hold Register Empty
TRE	Transmit Register Empty
TRC	Transmit clock
CRL	Control Register Load
PI	Parity Inhibit

The receiver section is a mirror image of the transmitter section. The serial data is disassembled from serial to parallel format, and the eight parallel bits are stored in a receiver register. The receiver output is the *hold register* which is connected to the eight-bit output lines. These output lines are tri-state types, so will float at a high impedance when not enabled. This feature allows us to connect the UART directly to a data bus, an application that will be covered later.

The receiver section also has its own signals: PE, FE, OE, RRD, DRR, RRC and SFD; which are defined as follows:

PE	Parity Error
FE	Framing Error
OE	Overrun Error
RRD	Receiver Register Disconnect
DRR	Data Receive Reset
RRC	Receiver Clock
SFD	Status Flag Disconnect

Basic UART Connections. One of the principal attractions of the UART device is the simplicity of its connection, allowing almost anybody to implement circuits based on the UART. The transmitter circuit is shown in Fig. 6, while the receiver circuit is shown in Fig. 7.

The transmitter requires eight input bits, a clock at 16× the baud rate, and certain programming commands. It also has a reset (pin no. 21 resets both the receiver and transmitter, as well as the status flags) control terminal. The control flags must be set either HIGH or LOW, depending upon the requirements of the situation. We apply +5 volts to each line through a 1000 ohm, ¼-watt

resistor, which sets the terminal permanently HIGH. A grounding switch will set the pin LOW if desired. In most of our applications, I suspect that these pins will be HIGH. In that case, they are shorted together, and then connected to the +5 volt line through a single 1000 ohm resistor. In an application later in this article, we will allow setting of the control lines under program control.

The receiver section is shown in Fig. 7, and it is even simpler than the transmitter section if the transmitter section is also included in the circuit. The reason for this is that the receiver section obeys the control signals wired into the transmitter section. If the receiver section is to be used alone, however, we will also have to include the appropriate control signals. Otherwise the circuit is the same as in Fig. 7. We have a 16× clock, serial input, eight output data lines, and certain flags: DR, PE, FE, and OE. We also have the DRR signal input. In the circuit shown the *data received* (DR) line is inverted and applied to the *data receive reset* (DRR) line. The inverter allows us to rest the DR flag.

UART Interfacing. The UART can be interfaced to the computer in several different ways. We can connect it directly to the data bus, either as a memory-mapped device or a dedicated I/O port, or, we can connect it directly to an I/O port of the computer. One of the applications to follow will allow you to interface the UART to existing parallel I/O ports of a microcomputer.

Figure 8 shows connection of the UART to a data bus. This particular method of connection is possible because all of the outputs of the UART are tri-state. This means that, unless the output is enabled, the line floats at a high impedance to both ground and +5 volts. But, when the line is enabled, it will have a low impedance to +5 volts when HIGH and a low impedance to ground when LOW. In Fig. 8, we take advantage of this feature and connect the receiver output lines in parallel with the transmitter input lines and the data bus of the microprocessor. We can connect the *master reset* (pin number 21), to either the system power/on reset, or, to some point that can be used to reset the UART.

The methods shown in Fig. 8 are basically for the 8080A device, but similar connections will allow use of the Z-80, 6502 or 6800 devices. Also, programming for each microprocessor will be different, so no examples will be given here.

A method for connecting the UART to I/O ports of an existing microcomputer is shown in Fig. 9.

The circuit in Fig. 9 uses two I/O ports to control the UART. Input port number 3 is connected to the receiver output lines of the UART. The receiver status flags are connected to input port number 4, although some of these will not be used by some programmers. There are two output ports used (3 and 4). Port number 3 is used to output the eight data bits, plus the control signals to the control inputs of the UART. Port number 4 is used to control the circuitry.

The 74100 device is used to store the control signals output from port number 3 so that the same port can also be used for the data bits to follow. But this IC is not strictly needed because the UART contains its own register to input the control signals. We could connect PI, SBS, WLS1, WLS2, EPE, and DRR to the output lines in parallel with the transmitter input lines. The CRL (control register load) line can then be brought HIGH

of it.

If you do want to buy a power mike, there are some things to remember. First, not all power mikes fit all radios.

Second, it takes some skill to install a power mike. And third, if your radio has a mike gain knob on it, you already have a power mike.

Now, I don't want to offend you or make you feel unwelcome, but why don't you take your radio and get out?!

INSIDE SUPERHETS

□ Born out of necessity during World War I, the superheterodyne receiver circuit topped all existing conventional receiver types on electronics' popularity chart. And, to this day, none of the "conventional" radios of that era have been able to recapture electronics' limelight. Stranger yet, every branch of electronics is still being swept along the path of Progress by a circuit that should have gone the way of the flivver and the flapper. From military and industrial to commercial and consumer—everybody who's ever seen a radio, and certainly a television set, has found himself staring face to face with a superheterodyne receiver. The fact is, you'd be hard-pressed to find any up-to-date radio—even the integrated-circuit-and-ceramic-transformer variety—that doesn't somehow utilize the superhet circuit.

After the First World War, the "All-American Five," at it was dubbed, took its place in living rooms and parlors from coast to coast. And it continues to be built today as its inventor generally conceived of it, way back when the circuit was made to track and help locate enemy aircraft spitting fire over French skies.

Narrow Squeeze. The superheterodyne found itself ruling the receiver roost largely because it had a redeeming quality no other receiver of that vintage era could boast. Called *selectivity*, this hitherto unheard-of quality endowed the superhet with the ability to select the particular station a listener wanted to hear (and later see), and reject all others. Indeed, it was a revolutionary step forward in receiver design. But selectivity was hardly a quality needed back in grandfather's day. Why?

First, grandpop used to listen to signals sent by spark-gap transmitters. The primitive spark signals generated by those common-as-apple-pie transmitters were extraordinarily broad. It was like listening to the lightning crashes you can pick up as you tune across the dial of an AM radio during a thunderstorm. More important, though, there were fewer signals on the air. So selectivity wasn't too important.

The year 1922 saw the meteoric rise of radio for entertainment and com-

munication. As hundreds of stations took to the air it became apparent that the primitive receiving gear capable only of broad-bandwidth reception couldn't even begin to handle the impending traffic jam beginning to build on the airwaves. And the problems of receiving only one station, without an electronic cacaphony drowning it out, takes us back even further into electronics' primeval time.

Cat's Whiskers and TRF. Digging through to the bottom of the twentieth century, we uncover two electronic fossils: the cat's whisker crystal receiver, and the tuned radio frequency (TRF) receiver. These were popular predeces-

sors of the superhet circuit.

The crystal set had the least selectivity of either circuit, and what it did have was obtained mostly from one measly tuning circuit. Consisting of a coil and a homemade variable capacitor, these crude tuning devices could barely pick out a desired radio signal and, hopefully, reject all RF intruders trying to elbow their way into the listener's headphone on either side of the signal. The cat's whisker consisted of a strand of fine wire for gently probing, or tickling, the crystal's natural galena surface in order to locate its most sensitive point. Though the cat's whisker detector could extract audio signals

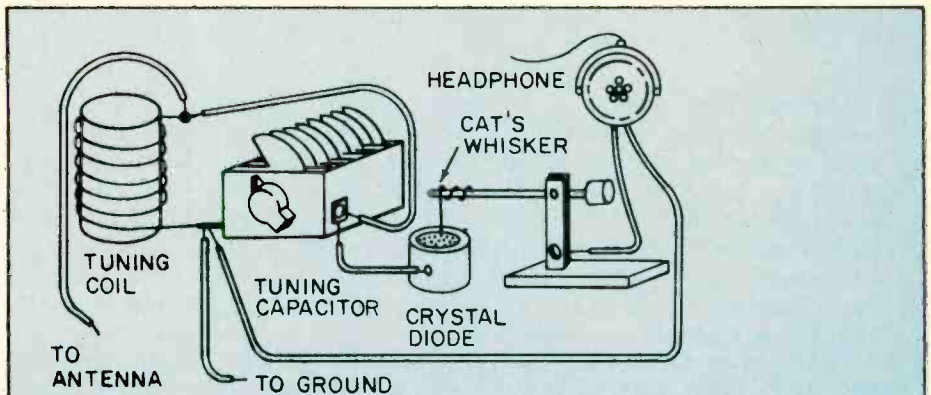
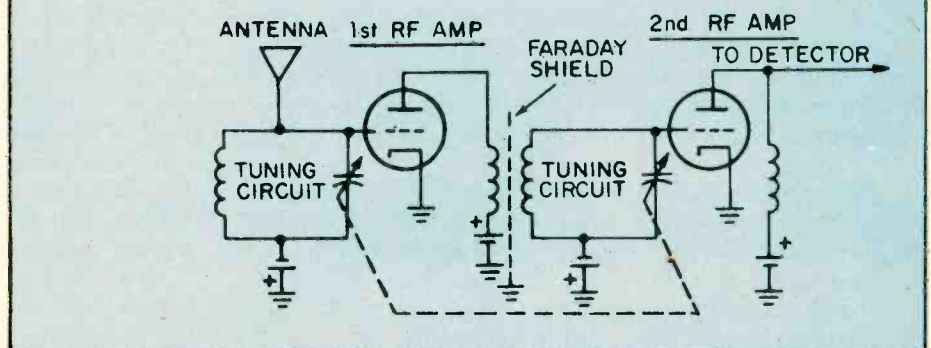

Fig. 1. Schematic representation of crystal radio shows how cat's whisker gently contacted diode surface in order to achieve demodulation of RF signal. Earliest semiconductor diodes made were miniature crystal diode/cat's whisker affairs encased in glass package.

Fig. 2. Our schematic shows relatively advanced tuned radio frequency receiver. First TRFs had individually adjusted tuning capacitors; ganged units were still to be invented. By adjusting battery voltage twist ground, tuning circuit, radio gain's varied.



from the amplitude-modulated radio frequency signal, the galena detector creasing the listener's chances of picking up stations other than the desired one.

Matters improved with the TRF receiver. It aimed for, and hit, sharper reception dead center, by adding more tuned circuits. This feat wasn't practical with crystal sets, because this circuit's inherent losses ran too high to gain any benefit from any additional coils.

The invention of the triode vacuum tube gave engineers the perfect amplifying device. Circuit losses could now be overcome with ease; the TRF took over where the cat's whisker left off, dooming the crystal set to mantelpiece and museum.

Three or four amplified radio-frequency stages were customarily added prior to the TRF's detector, all the while adding to selectivity's cause. However, all wasn't perfect in TRFville.

The amount of noise introduced by the tubes limited the number of TRF stages. So the Silver-Masked Tenor's strains could still be heard with those of the Clicquot Club Eskimos—but not by his choice, or that of the listener.

Pitching the Low Curve. The public soon learned that these newfangled TRF receivers weren't exactly the living end. The TRFs, as a rule, failed to perform satisfactorily as frequencies inched higher into kilohertz land. Seems that as the frequency of the signal went up, the TRF's tuned circuit efficiency for that frequency dropped almost proportionately.

To demonstrate this, look at our example. The bell-shaped curve represents response of a tuned circuit selecting some low-frequency station. The circuit delivers good selectivity, and interference on a slightly higher frequency is rejected.

But examine what happens when a similar tuned circuit is operated on a higher frequency. Although the curve's proportions remain the same, it's actually responding to a much greater span of frequencies. Now it's possible for two closely spaced stations to enter the response curve and ultimately be heard in the speaker.

Since tuned circuits grow more selective as frequency is lowered, wouldn't it be to our technical advantage to receive only low-frequency signals? This idea probably occurred to Major Edwin Armstrong, because his invention, the superheterodyne circuit, does just that.

Superselectivity. By stepping signals down to a lower frequency than they were originally, the new circuit could deliver neat-as-a-pin selectivity on almost any band. The fact is, this develop-

ment helped open the high-frequency bands, and by the 1930s virtually every receiver adopted the Major's superheterodyne idea.

The word "superheterodyne" is, by itself, revealing. It begins with *super*, for supersonic, referring to a new signal created within the radio. The generated signal is neither in the audio nor higher radio-frequency range, but in between. *Hetero* means combining, the *dyme* is force. The newly-created ten-dollar term, *superheterodyne*, neatly sums up this circuit's action.

Major Blocks. You can get a good picture of the superhet in its natural habitat if you look at our block diagram. Though our schematic shows a tubed receiver, all equivalent stages tend to do the same job regardless of whether the receiver is transistor or tube. Now that you know what the superhet does and how it looks, let's take a peek at how it works.

For sake of illustration, assume a signal of 1010 kHz in the standard BC band enters the antenna, and from there is sent down the line to the mixer. But what, you ask, is mixed?

Our frequency mish-mash consists of the different frequencies made up of the desired station on 1010 kHz, and a second signal generated internally by the local oscillator. This oscillator perks at a frequency of 1465 kHz, for reasons which you'll understand in a moment.

True to its name, our mixer combines both signals from antenna and oscillator. And from these two frequencies, it delivers yet another frequency that is the *difference* between them—namely 455 kilohertz. So far, our superhet circuit changed, or reduced the desired signal to a frequency having an

intermediate value. Beating two frequencies together in order to produce a third signal is known by members of the Frequency Fraternity as mixing, heterodyning, or beating. And some engineers prefer to call the lowly mixer a converter; this term often appears in schematics. But whatever name you throw its way, the result is the intermediate frequency.

There's something else you should know about the intermediate, or IF, frequency. It always remains the same no matter what station you tune to. If you sweep the dial across the broadcast band in one continuous motion, the IF frequency remains constant. How's this accomplished?

It's done by tuning the incoming signal simultaneously with the local oscillator. That's something akin to the mechanical rabbit which paces greyhounds at a race track. In the superhet a ganged tuning capacitor performs this dynamic-duo feat.

Take a close look at the tuning capacitor, and you'll see physically smaller plates assigned to the local oscillator. Since these plates are smaller than the antenna stage capacitor plates, the effect is to lower the capacity, and *raise* the frequency of the oscillator stage. That's how the oscillator stage consistently produces a signal which is 455 kHz above the incoming frequency. But why bother, you ask?

More Muscle, Too. When we convert each incoming station's frequency to the same IF, we gain another advantage besides better selectivity. A *fixed-tuned* amplifier always operates at higher efficiency than one which needs to muscle a multitude of frequencies. There are fewer technical bugaboos in

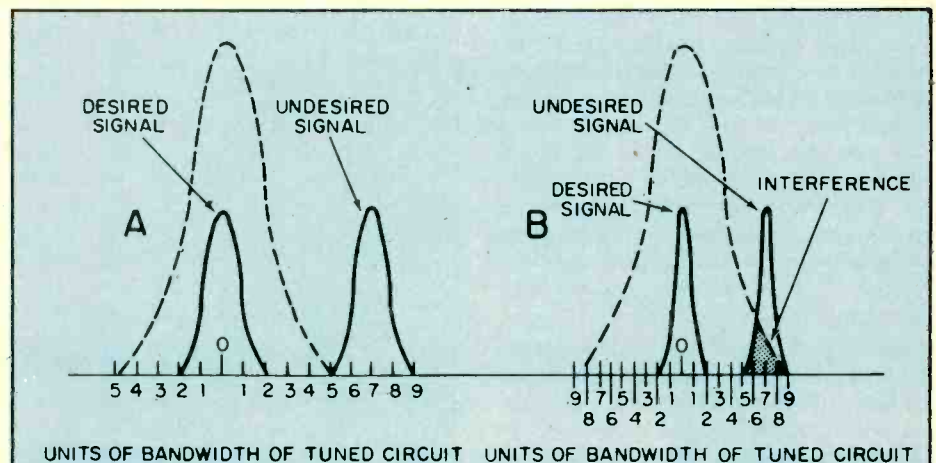

Fig. 3. Tuned-circuit bandwidth varies proportionally with frequency. Tuned circuit A, working at low frequency, rejects unwanted signal. Tuned circuit B, working at high frequency, can't completely reject undesired signal; interference results.

a one-frequency amplifier, so our tubes or transistors can operate more effectively at this lower frequency. And, last but not least, circuit layout and wiring are less critical. All of this is well and good, but how do we actually extract our Top-Forty tunes, news, and weather from our super-duper-het?

Sound Sniffing. The detector stage recovers original audio voltage from the station's signal. Since we're cranking the RF voltages through a superhet circuit, the RF signal did a quick disappearing act, only to appear as an IF frequency of 455 kHz. Though the original carrier (1010 kHz) is converted downward in frequency to 455 kHz, any audio voltage variations impressed upon the carrier remain the same. So if a musical note of 1000 Hz was sounded back in the radio studio, the note still remains that value in both RF and IF circuits, despite the mixing process.

Like a ladle skimming heavy cream off the top of a jug of fresh milk, the detector rectifies either the positive- or negative-going portion of the carrier, skimming off the audio signals from the carrier. Though audio modulation appears during both positive and negative swings of an amplitude-modulated carrier, only one half of the available signal is used. If both positive and negative portions of the RF signal were detected simultaneously, the audio signals would cancel each other at the output!

Now let's look at the stages of an ordinary solid-state superhet circuit that might be found in a common table radio or transistor portable.

Simplified Schematic. Our diagram is pretty typical of transistorized superheterodyne circuits. Of course, there may be variations on this circuit's theme, like the addition of an RF amplifier ahead of the mixer to improve sensitivity. The number of IF stages also varies with receiver quality, and specialized items such as filters may appear in ham and SWL rigs.

If you can follow our basic block diagram you'll have the key to virtually any solid-state superhet. In order to further simplify matters, many resistors and capacitors not essential to our tour through solid-state superhet country have been omitted.

Leading the pack on our superhet speedway is the antenna tuning circuit. Loopstick antenna L1 grabs the RF signal out of the ether, and also serves in partnership with the tuning capacitor in the tuning circuit. You sharpies will also notice that the antenna tuning capacitor is mechanically joined to the oscillator tuning capacitor. (This is represented schematically by a dotted line.) Remember now, we want to develop the

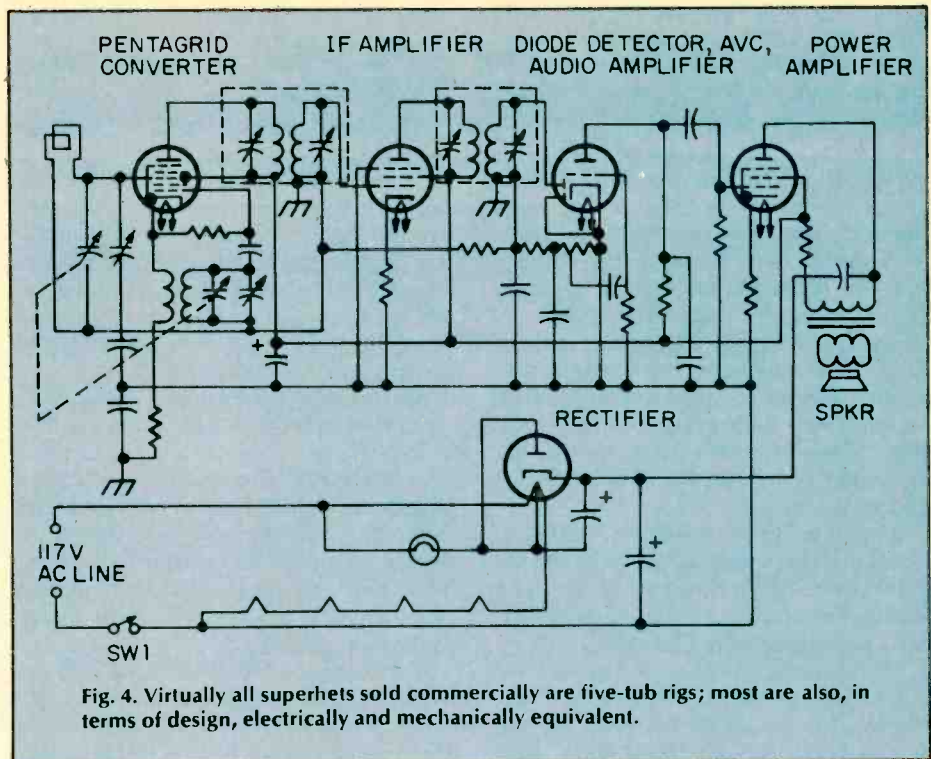

Fig. 4. Virtually all superhets sold commercially are five-tube rigs; most are also, in terms of design, electrically and mechanically equivalent.

IF frequency. This ganged, antenna/oscillator capacitor ensures the necessary *tracking* of the local oscillator with the radio-frequency signal.

The oscillator frequency is developed by the oscillator portion of our variable capacitor, and coil L2. In our superhet's schematic, the oscillator signal is capacitively coupled from the oscillator transistor base and sent on its way to the mixer stage. The mixer, therefore, "sees" both oscillator and incoming station frequencies. The electrons from oscillator and antenna circuit get it all together in the mixer's base, producing

our intermediate frequency:

If you could look at the mixer's output, you'd see more than just the IF signal. In fact, the mixer's load contains a jumble of frequency byproducts. As signals combine in this circuit, they add, subtract, and recombine in many ways. It's as if you had to separate the wheat from the chaff with a pair of tweezers!

Only the desired signal emerges from the mixer stage because intermediate-frequency transformer IF1 picks the proper signal to the exclusion of all the others. Now our freshly-created signal passes through a stage of IF amplifica-

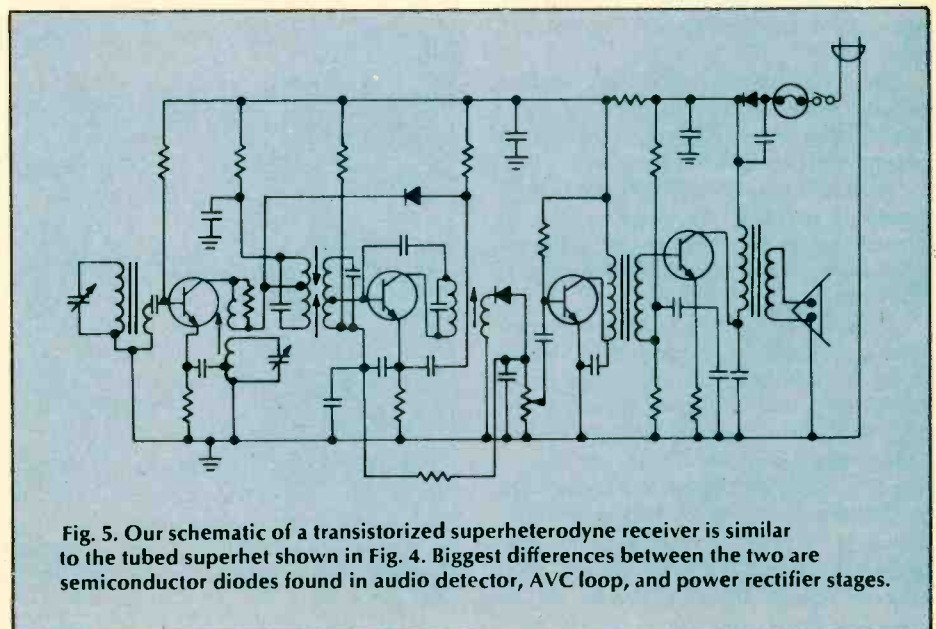

Fig. 5. Our schematic of a transistorized superheterodyne receiver is similar to the tubed superhet shown in Fig. 4. Biggest differences between the two are semiconductor diodes found in audio detector, AVC loop, and power rectifier stages.

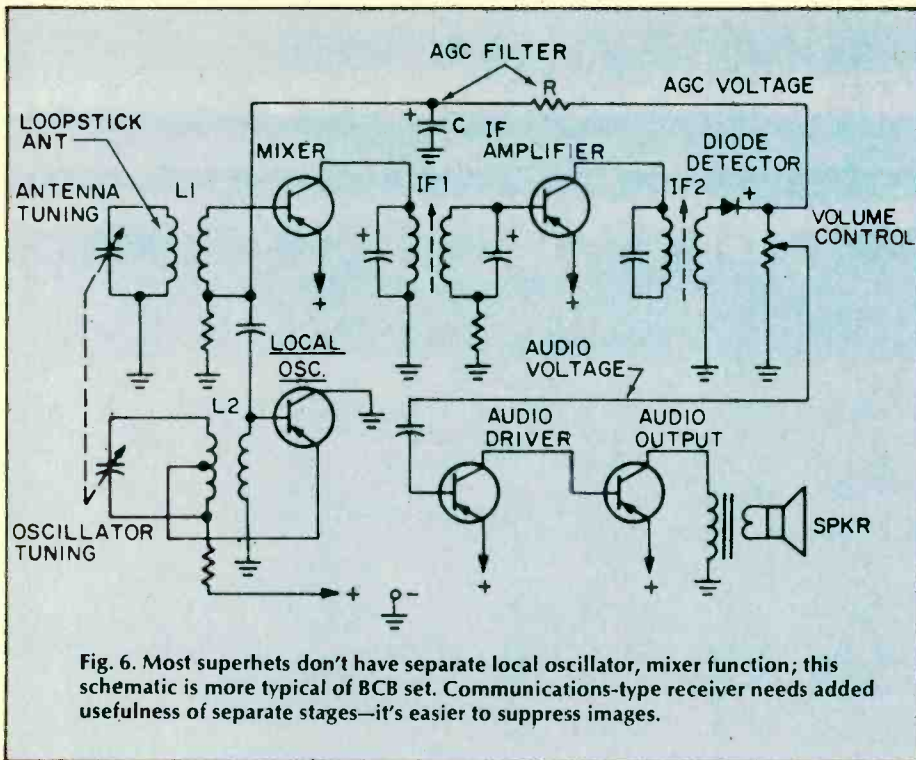

Fig. 6. Most superhets don't have separate local oscillator, mixer function; this schematic is more typical of BCB set. Communications-type receiver needs added usefulness of separate stages—it's easier to suppress images.

tion, and receiver selectivity is further whipped into shape by the second intermediate-frequency transformer, IF2.

As we've already described, the detection process takes place at the diode, regaining the radio station's original audio signal. This audio voltage is fed from the volume control to both audio stages where they're further amplified and sent to the loudspeaker.

The detector diode doesn't merely extract soul sounds from the ether; it also delivers a second voltage output. Called AGC (Automatic Gain Control), this voltage controls our mixer's amplification, preventing the speaker from blasting when you suddenly tune your radio to a strong station. In our simplified schematic, the AGC voltage is a posi-

tive-going voltage which increases proportionately with rising signal strength. But before AGC can control receiver gain, it's filtered for pure DC in a resistor and capacitor network.

The result is a DC signal which can be used to control the gain of the mixer transistor. Thus, if a strong RF signal tries to muscle its way through this stage, the mixer is subjected to a higher bias voltage on its base terminal, which tends to put the brakes on our mixer's gain.

Pitfalls, Yet. Let's not lionize the king of receivers, though, for sometimes its growl turns to a puny purr. The biggest problem, and the most annoying, is a form of interference peculiar to the superhet known as an *image*. Produced by a mathematical mixup, images are all of those undesired signals finding easy routes to travel through your receiver. Take a look at our image explanation; you'll see the receiver is tuned to a desired signal of 8000 kHz.

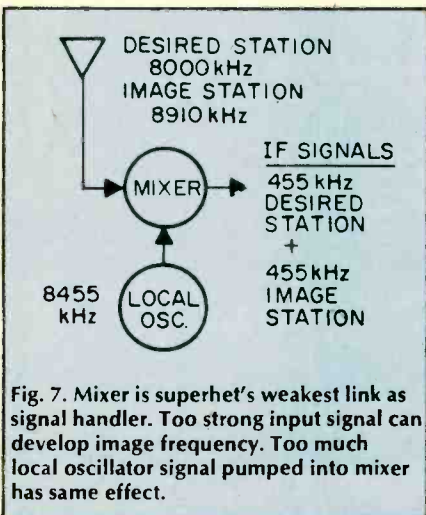

Fig. 7. Mixer is superhet's weakest link as signal handler. Too strong input signal can develop image frequency. Too much local oscillator signal pumped into mixer has same effect.

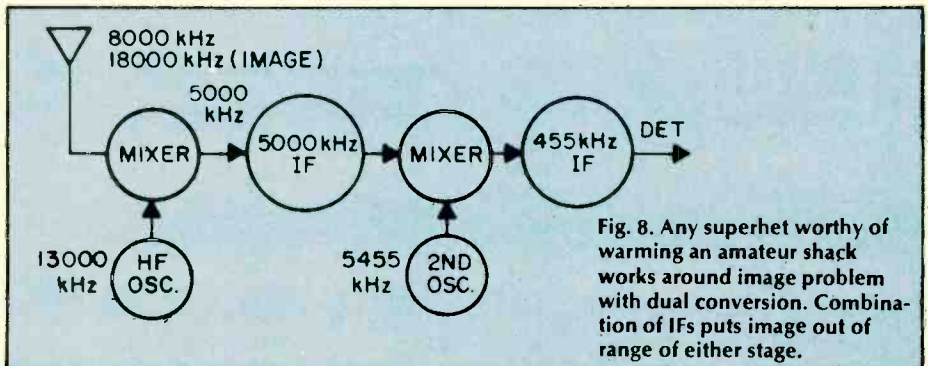

Fig. 8. Any superhet worthy of warming an amateur shack works around image problem with dual conversion. Combination of IFs puts image out of range of either stage.

The local oscillator generates a frequency of 8455 kHz, which places it exactly in our IF signal ball park. But note that a second station—a pop fly on 8910 kHz—also happens to be 455 kHz away from the local oscillator. For each oscillator frequency there are now two station frequencies giving identical IF frequencies. It's up to your receiver to strike out the image station. Otherwise, the RF ball game will turn into a rout!

You might expect the receiver's antenna tuning circuit to completely reject the image signal. After all, it's supposed to be tuned to generate a very high IF frequency, positioning any images developed by the mixer well outside the tuning range of the antenna circuit. Looking at our example of a double superhet, you'll see one IF amplifier perking at 5000 kHz and another working on 455 kHz. Now if we receive an incoming signal on 8000 kHz, the local oscillator, now called a high-frequency oscillator, generates a frequency at 13,000 kHz, so the first IF signal works out to 5000 kHz. Your receiver would have to pick up a signal falling on 18,000 kHz to produce any image. Naturally, the image frequency in this instance is significantly removed from the antenna circuit, so the image is greatly attenuated.

While high IF frequencies work well against image interference, they also revive Nagging Problem Number One: the higher the frequency of a tuned circuit, the poorer its selectivity. Since this situation also applies to IF stages, a *second* conversion is required, bringing the first IF signal down to 455 kHz, where we can sharpen our receiver's selectivity curve. That's how the double-conversion receiver solves both image and selectivity hassles. Any ham or SWL rig worthy of an on/off switch is sure to have this feature. But don't think of dual conversion as a receiver cure-all.

Dual conversion is *not* usually found in entertainment receivers—radio broadcast and TV for example, because it's too sharp! High selectivity could easily slice away sidebands in an FM stereo program and kill its multiplexed chan-

nel, or rob a TV image of its fine picture detail.

But, for all its faults, the basic super-

het circuit we've been talking about must be doing something right. Every year several million superhets are sold

in the U.S. Not bad for a circuit that might have gone the way of the hip flask, eh?

Lab Test C&E HOBBY HANDBOOKS For Yourself

In case you're not all that familiar with us, we're *not* a publication for electrical engineers and other wizards. No way, C&E HOBBY HANDBOOKS are expressly for people who like to build their own projects and gadgets—and maybe get a little knee-deep in tape, solder and wire clippings in the process.

In fact, we have a sneaking suspicion that our readers like us because they think we're just as bug-eyed and downright crazy over great new project ideas as they are. And I guess they're right!

C&E HOBBY HANDBOOKS thinks of you who dig electronics as the last of a special breed. It's more than just the "do-it-yourself" angle—it's also the spirit of *adventure*. In this pre-packaged, deodorized world, building your own stereo system, shortwave receiver, darkroom timer or CB outfit is like constructing a fine-tuned little universe all your own. And when it all works perfectly—it really takes you to another world.

**C&E HOBBY HANDBOOKS
knows the kinds of projects
you like—and we bring 'em
to you by the truckload!**

Ever hanker to build a sharp-looking digital clock radio? Or to hook up an electronic game to your TV? Or an easy-to-build photometer that makes perfect picture enlargements? Or a space-age Lite-Com so you and the family can talk to each other on a light beam? We've got it all to get you started.

Has your sound system gone blooey just when the party's going

Get switched on

great? Do you shudder when your friendly neighborhood electrician hands you the bill? C&E HOBBY HANDBOOKS can help.

Of course, we can't make you a master electrician overnight. But we can show you the fundamentals of repair plus maintenance tips.

IF YOU'RE NEW TO ELECTRONICS YOU GET A "BASIC COURSE"!

It gives you the complete, ground-floor lowdown on a variety of important electronics subjects. For example—Understanding Transistors ... How radio Receivers Pull in Signals ... Cathode Ray Tubes Explained ... How Capacitors Work ... Using Magnetism in Electronics. And more!

ENJOY GREAT ARTICLES LIKE THESE

- How to Build Your Own Transformer
- How to Select the Right Shortwave Receiver
- The Burgeoning World of Microcomputers
- Quickdraw Rickshaw—The Electric Car that Really Gets Around
- What's Really Wrong with FM Radio?
- How to Power-Up Your Antique Radio
- The Vanishing Vacuum Tube
- How to Customize Your CB Antenna
- Those Incredible TV Sets of the Future
- Listening in on the Forgotten Continent
- DXing Endangered Species
- Sandbagging—CB Fun Without a License
- The World's Worst Hi-Fi Components

TRY A FEW ISSUES AND EVALUATE OUR ...

- **HOW-TO-DO-IT HELP.** Tips and pointers that add up to money saved. For example—tuning up your tape player ... all about radios ... whys and hows of turntables ... care and feeding of speakers.

- **EXCITING DISCOVERIES.** Whatever your particular interest in electronics, you'll be entering a world of discovery in the pages of C&E HOBBY HANDBOOKS

