

HAM TIPS

from



Published by RCA Manufacturing Company, Inc., Camden, N. J., U. S. A.

VOL. 2 — No. 3

CAMDEN, N. J.

MAY—JUNE, 1939

REINARTZ TAKES POSITION WITH U. S. NAVY DEPT.

Will Administer Field Activities of N. C. R.

Mr. J. L. Reinartz, who for the last few years has been associated with RCA as technical consultant on amateur tube applications, recently left RCA to take on new work with the U. S. Navy Department. As liaison officer for the Naval Communications Reserve, in the office of the Director of Naval Communications, he will administer the field activities of this organization from Washington.

Radio amateurs from coast to coast will remember the many interesting lectures and demonstrations given by Lieutenant Reinartz while on his numerous speaking tours sponsored by RCA. His many friends at RCA and in the amateur fraternity all wish John the best of luck and success in his new work.

HAS 30-WATT FILAMENT

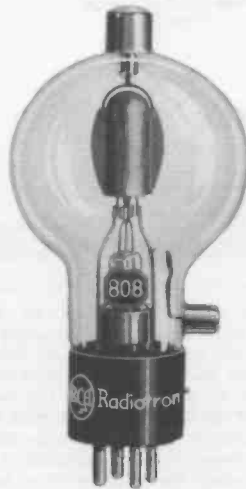

The RCA-808 high-perveance triode is an excellent tube for cw or phone rigs of the medium power class. Amateur net price is only \$7.75 at all RCA Power Tube Distributors.

RCA-808 TANTALUM-PLATE TRIODE FB FOR MEDIUM-POWER RIGS

Push-pull 808's Take 400 Watts Input on CW —270 Watts on 'Phone

A large percentage of all amateur transmitters, both 'phone and cw, fall in the medium-power range where the input to the final stage runs somewhere between 100 and 300 watts. The RCA-808 is one of the best triodes available for transmitters in this power class. A single 808 can be operated at a d-c plate input up to 200 watts in cw service, and up to 135 watts in plate-modulated-telephony service.

WINNER!

W3BES, owned by Jerry Mathis of Philadelphia won the 9th A.R.R.L. Sweepstakes with a pair of RCA-809's in his final amplifier! During 40 hours of 1938 contest, W3BES worked 502 stations. His total score was 84,001.25 — a real record.

The 808 has a sturdy, heavy-duty, thoriated-tungsten filament designed to operate at 7.5 volts and 4 amperes, or 30 watts. The ruggedness and generous electron-emitting capability of this filament can be appreciated by comparing it to the 32.5-watt filament used in the old-familiar 203-A and 211 tubes, which have twice the rated plate dissipation of the 808. The tantalum anode of the 808 not only gives the tube a high instantaneous overload capability, but assists in maintaining a high vacuum.

Grid and Plate Connections On Bulb

The manner in which the grid and plate leads of the 808 are brought out through the bulb to metal cap terminals helps to insure good insulation and low inter-electrode capacitances. This construction also simplifies the mechanical layout and wiring of a push-pull stage employing a tuned-grid circuit, with link coupling to the driver.

Due to its small, close-spaced electrodes, high perveance, and low grid-plate capacitance, the 808 is particularly suited for efficient operation on the higher frequency amateur bands—40, 20, 10, and 5 meters. It is rated for full input at frequencies up to 30 Mc., and for 75% of maximum input up to 60 Mc. At 10 meters, the 808 operates as stably and is practically as easy to drive as at 20 meters. Many amateurs use a single 807 in the output stage of their exciter units. It so happens that a single 807 operating at 60 watts input will furnish just the right amount of excitation for two 808's in push-pull, even when the latter are plate-modulated—at frequencies up to 30 Mc. Thus, the 807—push-pull 808 arrangement makes a very logical combination.

Push-pull 808's, CW Telegraphy Circuits UC-17 and UC-18 show such a transmitter, designed for break-in

(Continued on page 2, column 1)

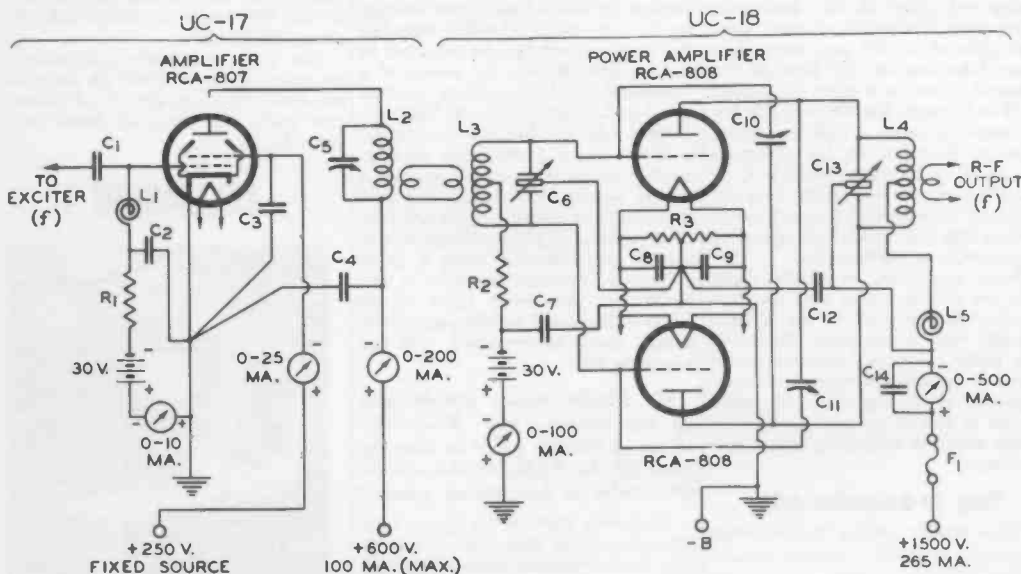

CW TELEGRAPH TRANSMITTER

Power Output 300 Watts*

C₁ = 15 to 50 μ f mica
 C₂, C₃, C₄ = 0.005 μ f mica
 C₅ = 2 μ f/meter*
 C₆ = 2 μ f/meter/section*
 C₇, C₈, C₉, C₁₁ = 0.005 μ f mica
 C₁₀, C₁₂ = 2.8 μ f*
 C₁₃ = 0.002 μ f, 5000 v.

C₁₄ = 1.1 μ f/meter/section†
 R₁ = 7000 ohms, 1 watt
 R₂ = 2800 ohms, 25 watts
 R₃ = 50 ohms, c.t., wire-wound
 L₁, L₂ = R-f choke
 L₃, L₄, L₅ = Tune to frequency "†"
 L₅ = R-f choke, 300 ma.

F₁ = $\frac{1}{2}$ A. high-voltage fuse
 f = Operating frequency
 * Approximate.

† Capacitance in actual use.
 NOTE: Rotor shaft of C₁₂ is at the d-c plate potential; an insulated coupling shaft must be inserted between the rotor shaft and the control dial.

HAM TIPS from RCA

RCA-808 Triode FB For Medium-Power Amateur Rigs

(Continued from page 1, column 4)

operation where the crystal oscillator is to be keyed. A 6L6 can be used in the oscillator stage (see circuit UC-1 in Sept. *Ham Tips*), followed by as many frequency doublers as may be required. A 6L6 connected as a high- μ triode, with the screen tied to the control grid, makes a good doubler for this purpose due to the fact that no fixed bias is required (at a plate voltage of 400 volts) to reduce its plate current to a safe value when the key is in the oscillator stage is up.

With a 40-meter crystal, the oscillator plate circuit can be used to double to 20 meters so that 20-meter operation can be obtained with the oscillator driving the 807 directly, with no intermediate doublers required. For 10 meters, only one doubler is needed between the oscillator and the 807, assuming again that a 40-meter crystal is used. The 807, in this transmitter arrangement, should usually be operated as a straight amplifier, rather than as a doubler, so as to furnish adequate excitation to the 808's.

Push-pull 808's, Plate-Modulated

If it is desired to use plate modulation with amplifier stage UC-18, a few changes are necessary. The d-c plate input should not exceed 135 watts per tube, or 270 watts total. With a plate supply of 1250 volts (the maximum rating for plate-modulated telephony), an input of 270 watts is obtained at a d-c plate current of 216 ma. The use of partial fixed bias is not essential; therefore, the 50-volt "C" battery can be omitted. The required grid bias of -225 volts (approx.) can be obtained from grid leak R_2 , the value of which should be changed to 3500 ohms. The total d-c grid current should be adjusted to a value somewhere between 60 and 70 ma.

The "modulation impedance" of the push-pull stage is $R = E/I$, or $1250/0.216 = 5800$ ohms (approx.). For 100% sine-wave modulation of the 270-watt input to the r-f stage, a modulator delivering 135 watts of audio power is required. This a-f power can be obtained quite easily from two 808's in class B, which are rated to deliver 190 watts at 1250 volts. This arrangement has the advantage that a single 400-ma., 1250-volt power supply can be used for both the final r-f stage and the class B modulator.

Power Supply Should Have Good Regulation

The power supply, which should have excellent voltage regulation, might well consist of two 866's in a full-wave rectifier circuit, with a 15- or 20-henry choke-input filter. Allowing about 100 volts drop for the rectifier tube and filter, the power transformer should have about 1500 volts RMS each side of the high-voltage center tap. A two-section filter with a 4- μ f filter condenser

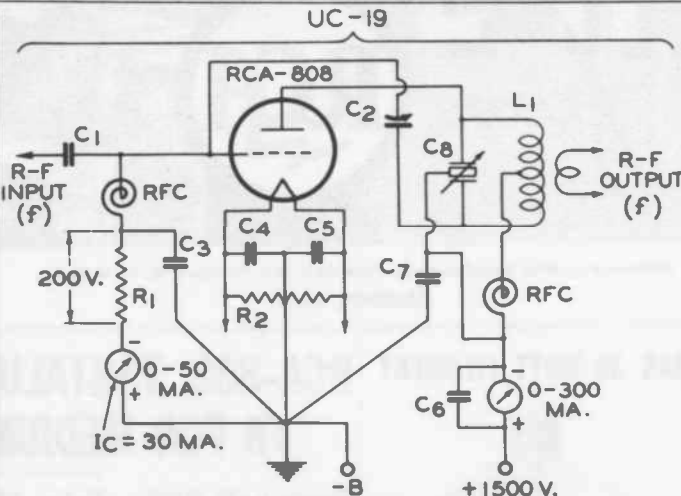

Class C Telegraph Power Output 150 Watts*

$C_1 = 0.0005 \mu\text{f mica}$
 $C_2 = 2.8 \mu\text{f}^*$
 $C_3 \text{ to } C_5 = 0.005 \mu\text{f mica}$
 $C_6 = 0.002 \mu\text{f mica, 2000 v.}$
 $C_7 = 0.6 \mu\text{f/meter/section}$
 $R_1 = 6700 \text{ ohms, 10 watts}$
 $R_2 = 50 \text{ ohms, c.t., wire-wound}$
 $L_1 = \text{Tune to frequency "f"}$

RFC = R-f choke
 $f = \text{Operating frequency}$
 $\mu = \text{Approximate.}$
 $\uparrow = \text{Capacitance in actual use.}$

NOTE: Rotor shaft of C_8 is at the d-c plate potential; an insulated coupling shaft must be inserted between the rotor shaft and the control dial.

QUESTIONS AND ANSWERS

by RCA's Engineering Department

Q. Is it characteristic of the RCA-808 to show color on its plate at very low power inputs? How can one tell when the plate of an 808 is dissipating the rated amount of power?

A. It is perfectly normal for the 808, 806, and other tubes employing tantalum anodes to show a bright, orange-red color at the maximum rated plate dissipation of each type. The plate of an 808 may even show some color due to the heat of the filament alone. At a plate dissipation of 12 to 15 watts, the 808 will definitely begin to show a dull red color. Thus, at the relatively low power input of 45 or 50 watts, in class C r-f amplifier service, some plate color can normally be expected; it is not necessarily a sign that the tube is operating improperly, or inefficiently.

Some amateurs, especially those who are used to tubes with graphite anodes, do not like to see a tube operate with a red plate. However, the plate color of tantalum-anode tubes is actually of value, in many cases, as a warning when the plate circuit is out of resonance and as a rough means of indicating circuit performance.

Easy to determine color

It is a simple matter to determine

before and after a 10-henry smoothing choke will provide a d-c output voltage having less than 0.5% ripple. No filter condenser should be used ahead of the input choke.

For information on a single-ended 808 r-f amplifier, please refer to the discussion of circuit UC-19.

exactly what plate color an 808 should show when it is dissipating its maximum rated power of 50 watts. The grid lead should first be shorted directly to ground, or to the midpoint of the filament circuit, with the r-f excitation removed. The d-c plate input should then be adjusted to 50 watts while the tube is in a non-oscillating condition. The plate voltage and current values can easily be adjusted until their product equals 50 watts, by means of an adjustable resistance in series with the positive high-voltage lead. This method requires both a plate milliammeter and a plate voltmeter. If it is more convenient to use a fixed plate voltage for the test—say 1250 volts—then the d-c plate current can be adjusted to the required 40 ma. by means of a variable d-c grid bias voltage inserted in the grid return lead to the filament. A 22½-volt "C" battery shunted by a 25,000- or a 50,000-ohm potentiometer (receiver type) will provide a simple means of varying the grid bias and plate current. If the test is to be accurate, the plate voltage should always be measured with a good voltmeter. Because the tube is not oscillating, the entire input of 50 watts is dissipated by the plate. Such a test, made as described, will not harm the tube.

Q. Under some conditions of operation, my RCA-807 shows a bluish color in the top part of the bulb. Is this a sign the tube is becoming gassy?

A. A blue glow in the top or near the sides of the glass bulb is usually due to fluorescence caused by stray electrons from the cathode which strike the interior of the bulb. This fluorescence is a natural effect and in no way indicates that the tube is not performing properly. A gassy tube is usually indicated by a blue glow inside the electrode structure, between the cathode and plate.

RCA-808 HAS 150 WATTS OUTPUT ON CW-100 ON 'PHONE

A typical single-ended r-f amplifier employing an RCA-808 is shown in circuit UC-19. Operating at its maximum rated d-c plate input of 200 watts in class C telegraph service, the 808 is capable of delivering an output of about 150 watts. An 807, 809, or 6L6, operating as a frequency doubler, is suitable for the driver stage. The r-f output of the driver should be in the order of 15 to 20 watts (for a discussion of driving-power considerations, refer to page 146 in the TT-3 Transmitting-Tube Manual).

In this circuit, capacity input coupling and grid leak bias are used because of their simplicity and convenience. Keying can be accomplished in the filament center-tap return to ground. If the oscillator stage is to be keyed for break-in operation, a partial fixed bias of about 30 volts (from a battery or other suitable d-c source) should be used, in order to reduce the plate current of the 808 to a low value when the key is up. The remaining 170 volts of grid bias can be obtained from grid leak R_1 , the value of which should be reduced to about 5700 ohms.

Single 808, Plate-Modulated

If it is desired to plate-modulate the single-ended 808 amplifier shown in circuit UC-19, the plate-supply voltage should be reduced to 1250 volts. At this plate voltage, the d-c plate current corresponding to the maximum rated d-c power input of 135 watts is 108 ma. A carrier output of slightly over 100 watts can be expected with these operating conditions. The "modulation impedance" of the 808 stage is $1250/0.108$, or about 11,600 ohms.

For 100% sine-wave modulation, an audio power of about 68 watts is required. This amount of a-f power can easily be obtained from two 809's in class B.

TELEVISION



RCA Victor Television Attachment TT-5. Has 24 tubes plus 5" kinescope. Attaches to any radio for sound.