

HAM TIPS



A PUBLICATION OF THE RCA TUBE DIVISION

Vol. XV, No. 4

December, 1955

A SECONDARY FREQUENCY STANDARD

By R. M. Mendelson, W2OKO

RCA Tube Division, Harrison, N. J.

W2OKO set out to design a frequency standard for ham use that would equal or surpass the performance of many commercial units. After reading his article most hams will be inclined to agree he has succeeded admirably. Here is a secondary frequency standard that can be built by the average ham with little difficulty and, more important, at low cost. It provides accurate and highly stable 10-Kc, 100-Kc, and 1-Mc markers, with the 1-Mc markers readable up to 250 Mc. In addition to marking the ends of amateur bands, it may be used for receiver calibration, for frequency measurement of received signals, for supplying an accurate, stable signal when "polishing" crystals, and as a signal generator for intermediate-frequency or front-end alignment.



"The licensee of an amateur station shall provide for measurement of the emitted carrier frequency . . . of sufficient accuracy to assure operation within the frequency band used." (FCC Regulation 12.135)

A versatile frequency standard providing 1-Mc harmonics readable to at least 250 Mc, 100-Kc harmonics readable to 150 Mc, and 10-Kc harmonics readable to 30 Mc is described in this article. The fifth harmonic of the 1-Mc oscillator may be set to within less than $\frac{1}{2}$ cycle of the 5-Mc signal of WWV—the radio station of the National Bureau of Standards. This is an accuracy of better than one part in 10 million. And, if the instrument is allowed to warm up, its setting after 24

hours of operation in a room of fairly constant temperature will still be within 5 cycles of the 5-Mc signal of WWV—a drift of no more than one part per million. These figures may be more clearly appreciated when it is realized that the dials of the most expensive amateur communications receivers have divisions no smaller than 1 Kc, and are readable at best to 500 cycles.

The complete schematic diagram of the unit is shown in Figure 1. A cathode-coupled crystal oscillator circuit utilizing an RCA-12AT7 (V_1) operates at a fundamental frequency of 1 Mc. One triode section of V_1 operates as a cathode follower, the other triode section as a grounded-grid amplifier. The crystal and capacitor C_4 act as a series-

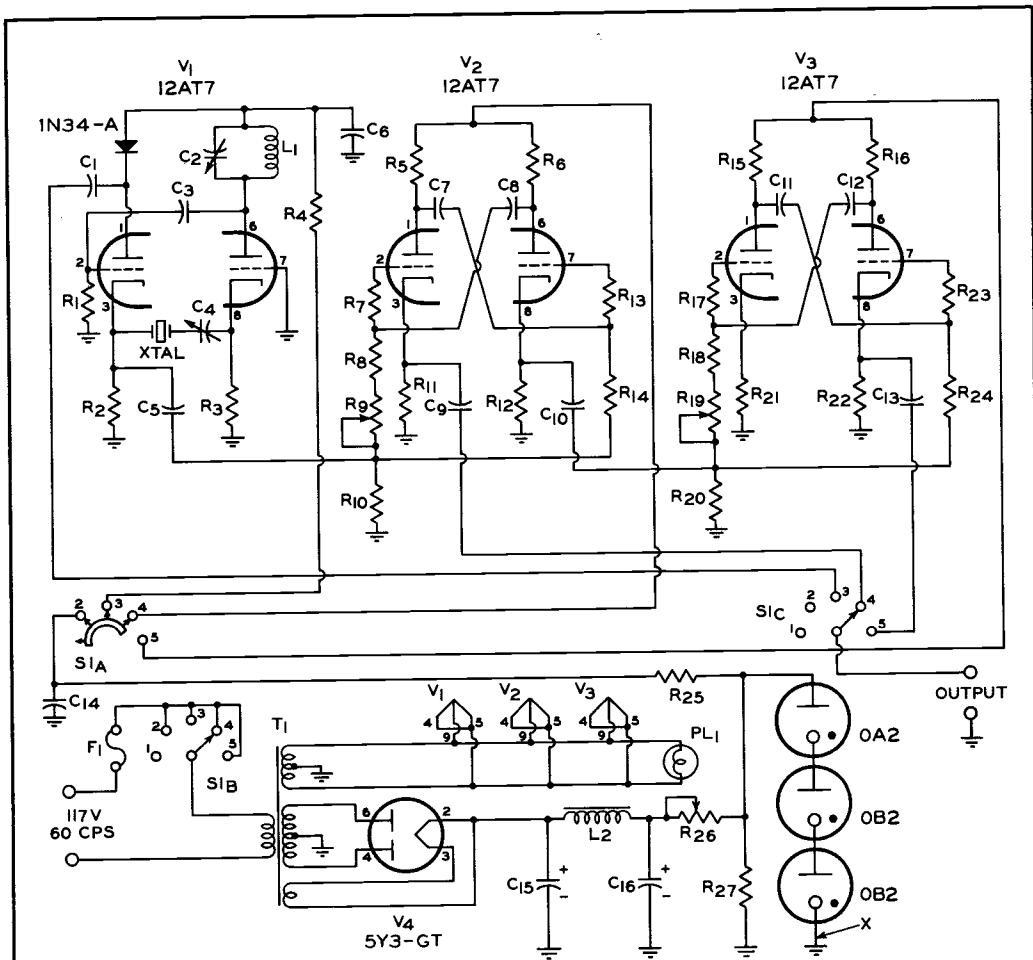

Figure 1. Schematic diagram and parts list. Positions of the three-pole ganged switch S1 are as follows: 1—Off; 2—Standby; 3—1 Mc; 4—100 Kc; 5—10Kc (S1 shown in 100-Kc position). S1 switches three circuits, but only two switch sections are needed because S1A and S1B are on opposite faces of same section.

- | | | | |
|---------------------|--|---------------------|--|
| C ₁ | 15 μ mf silver mica (Sangamo RR-1415). | R _{7, 13} | 200 ohms \pm 5%, 1 watt. |
| C _{2, 4} | 50 μ mf variable, with lock (Hammarlund APC-50C). | R _{6, 18} | 5,500 ohms \pm 1%, 1 watt (Continental Carbon X1). |
| C ₃ | 500 μ mf silver mica (Sangamo RR-1350). | R _{9, 19} | Potentiometers, 5,000 ohms (Clarostat 58-5000). |
| C ₅ | 2000 μ mf silver mica (Sangamo CR-1220). | R _{14, 24} | 7,450 ohms \pm 1%, 1 watt (Continental Carbon). |
| C ₆ | 2500 μ mf mica (Elmenco CM-30). | R _{15, 16} | 39,000 ohms \pm 5%, 1 watt. |
| C _{7, 8} | 270 μ mf silver mica (Sangamo RR-1327). | R _{17, 23} | 51 ohms \pm 5%, 1 watt. |
| C ₉ | 100 μ mf silver mica (Sangamo RR-1310). | R ₂₅ | 1,000 ohms \pm 5%, wire-wound, 10 watts. |
| C _{10, 13} | 1000 μ mf silver mica (Sangamo RR-1210). | R ₂₆ | 3,000 ohms wire-wound adjustable, 10 watts (Ohmite 1029). |
| C _{11, 12} | 1500 μ mf silver mica (Elmenco CM-30). | R ₂₇ | 82,000 ohms \pm 5%, 1 watt. |
| C ₁₄ | .01 μ f ceramic (Erie GP-333). | S ₁ | 3-pole, 5-position ceramic rotary switch (Centralab sections GG, R, and index assembly P121). See text for modification. |
| C _{15, 16} | 40 μ f, electrolytic, 500 WVDC (Mallory FP-288). | T ₁ | Power transformer, 320-0-320 v, 70 ma; 5 v, 2 amp; 6.3 v, 2.5 amp. (Stancor PC8408). |
| F ₁ | Fuse, 3 AG, 2 amp. | XTAL | Crystal, 1 Mc \pm .0025%, hermetically sealed (International Crystal Manufacturing Co. FX-1). |
| L ₁ | Plate tank inductance (Grayburne Varichoke V6). See text for modification. | | |
| L ₂ | Filter choke, 8 h, 85 ma (Stancor C1709). | | |
| PL ₁ | Pilot light, 6-8v (#40 or #47). | | |
| R ₁ | 100,000 ohms \pm 5%, 1 watt. | | |
| R _{2, 3} | } 1,000 ohms \pm 5%, 1 watt. | | |
| R _{10, 11} | | | |
| R _{12, 20} | | | |
| R _{21, 22} | | | |
| R ₄ | | | |
| R _{5, 6} | 3,000 ohms \pm 5%, 1 watt. | | |
| | 10,000 ohms \pm 5%, 1 watt. | | |
| | | Miscellaneous | |
| | | Chassis | 7" x 9" x 2", steel (Parmetal C-4511). |
| | | Cabinet with Panel | 12 $\frac{3}{4}$ " x 8" x 8 $\frac{1}{2}$ ", steel (Parmetal CA-300). |
| | | Turret Sockets | 9-pin (Vector type 6N9T). Three needed. |
| | | Crystal Socket | Ceramic (Millen 33302). |
| | | Binding Posts | (Superior 5-way). Two needed. |

resonant circuit between the two cathodes. Because the crystal operates in a low-impedance circuit, it is affected only slightly by variations in tube or stray capacitance across it.

The fundamental frequency of the crystal oscillator circuit may be varied several hundred cycles by adjustment of C_4 . This flexibility eliminates the need for a specially calibrated crystal and allows any well-designed hermetically sealed crystal to be used.

L_1 and C_2 form a circuit that is parallel-resonant at 1 Mc and serves as the plate-load impedance for the grounded-grid amplifier. C_3 provides feedback to the grid of the cathode follower. The RCA-IN34-A diode provides high harmonic content in the cathode-follower output.

V_2 and V_3 , also RCA-12AT7's, are cathode-coupled multivibrators operating at 100 Kc and 10 Kc, respectively. V_2 is controlled by the injected 1-Mc signal from the crystal, and is synchronized at the proper sub-harmonic by adjustment of R_9 . V_3 is controlled by the injected 100-Kc signal from V_2 and is synchronized at the proper sub-harmonic by adjustment of R_{10} .

The stability of this frequency standard is enhanced by voltage regulation of the power supply and by careful layout that keeps heat away from the crystal.

Construction

Although the oscillator is, in itself, very stable, its best performance can be obtained only with sturdy construction. Toward this end, turret sockets are used for the three frequency-generating stages. The terminal lugs on the turrets hold the small parts rigidly and minimize the effects of vibration or shock. To minimize rf losses, bus wire leads are used extensively. And finally, only "quality" parts are used. The advantage of a resistor or capacitor that will hold its value with age more than offsets the few cents extra in cost.

The placement of components has been carefully designed to keep heat sources away from the crystal and the one-megacycle tuned circuit, and it is suggested that the builder follow the layout illustrated in Figures 2 and 4.

Instead of the usual practice of fastening the chassis to the lower portion of the panel, this chassis is bolted to the panel about half-way up. This arrangement allows freer circulation of air within the cabinet, and at the same time yields a neater panel appearance. Two screws through the back of the cabinet support the chassis from the rear.

To provide a small, sturdy coil (L_1) for

the 1-Mc tuned circuit, it was deemed best to use a commercial slug-tuned coil. However, the coil specified in the parts list had slightly too much inductance to resonate at 1 Mc in the circuit as built at W2OKO. Rather than pull turns off the heavily waxed coil, a small brass slug 11/16" long by 1/4" in diameter (cut from an old potentiometer shaft) was used in place of the original iron slug in the coil form. The iron slug was removed and the brass one cemented into the open end of the coil form, flush with the end of the form. This brass slug lowered the inductance of L_1 sufficiently to allow it to resonate at 1 Mc with C_3 and the associated stray capacitance. [*The 1-Mc coil LS-3 manufactured by Cambridge Thermionic Corp. should resonate without modification in this circuit. Ed.*]

The other item to be modified is the ceramic switch. If the switch is assembled from the components specified in the parts list, it is

VALUABLE DATA FOR HAMS

A revised and enlarged edition of the *RCA Receiving Tube Manual*—for many years the amateur's guide to electron tubes and circuits—is now available from your RCA tube distributor.

Like former editions, the latest Manual contains a well-rounded section on electron-tube theory, tube characteristics and applications. Another section contains 22 schematic diagrams illustrating tube applications. And this new 336-page edition features a 26-page supplement filled with data on 51 tube types recently added to the RCA line.

All-in-all, the revised *RCA Receiving Tube Manual* (RC-17) belongs close to hand in every ham shack.

While you're at it, ask your RCA tube distributor to show you the newest edition of RCA's popular *Power and Gas Tubes Booklet* (Form PG-101B). This completely revised 24-page booklet contains the latest technical data on 178 vacuum power tubes; gas, mercury-vapor, and vacuum rectifier tubes; gas and mercury-vapor thyratrons; ignitrons; magnetrons; and vacuum-gauge tubes. Each tube type is covered by a text description, tabular data, and a base- or envelope-connection diagram—all easy to locate and highly informative. In addition, photographs are shown of many representative tube types. No matter what your interest is in power or gas tubes and their applications, the new *RCA Power and Gas Tubes Booklet* is sure to be of value.

only necessary to hacksaw carefully through the shorting ring of the GG section, drill out one rivet and remove part of the ring, as shown in Figure 3. This modification provides single-knob control for application of high voltage to the proper tubes as the various output frequencies are selected.

Adjustment

After the wiring has been carefully checked, adjust R_{26} to about 2000 ohms, and insert a 50-ma meter in series with the string of voltage regulator tubes (at point X in Figure 1). Apply ac power by rotating the control knob to "Standby." After warm-up, note the current flowing through the regulator tubes. A value of 30 ma is desired. *Shut off the power* and adjust R_{26} accordingly. It will later be noted that as V_1 , V_2 , and finally V_3 are put into operation by the control switch, the regulator current will drop, due to current drain by these tubes. If 30 ma of regulator current flows during standby, there should still be a slight current flowing in the 10-Kc position, when all tubes are operating.

Loosely couple the frequency standard to a communications receiver. With capacitors C_2 and C_4 at mid-position, turn the control switch to the "1 Mc" position and locate a low harmonic signal at, for example, 2, 3, or 4 Mc. With the receiver beat-frequency oscillator turned off, adjust C_2 for a maximum reading on the receiver's S-meter. It should now be possible to detect clean, strong, signals at 1-Mc intervals up to well over 250 Mc.

To adjust the 100-kc multivibrator, set potentiometer R_9 to mid-position and tune the receiver to a band where continuous coverage of at least 1 Mc is available. It is now best to operate with the receiver bfo turned on. Locate and note two points on the dial 1 Mc apart by tuning in signals from the standard. Rotate the control switch to the 100-Kc range, and tune in one of the multivibrator harmonics between the 1-Mc markers. If R_9 happens to be set properly, the note should be clean; if the note is rough, adjust R_9 to give a steady, controlled signal. Then, starting at one of the previously noted 1-Mc marks, tune the receiver through the range to the other marker. Numbering the first 1-Mc marker as "1", there should be 11 markers up to and including the last 1-Mc marker note. If there are less, increase R_9 ; if more, decrease R_9 to obtain control at the correct sub-harmonic of 1 Mc. Repeat the process until the proper number of markers are counted. These should be clean signals, with no rough notes between. In this condition, signals should be heard in a good receiver to well over 150 Mc.

To adjust the 10-Kc multivibrator, set potentiometer R_{19} to mid-position and tune the receiver to a band where a continuous coverage of at least 100 Kc is available. As above, locate two end points—this time 100 Kc apart—and then rotate the control switch to the "10 Kc" position. Proceed as before. Tune in a signal between the 100-Kc markers, adjust R_{19} for a smooth note, then count the notes between the end markers. Adjust R_{19} for a count of 11 clean beats (including the end markers).

At this point, check that the voltage regulator tubes are still glowing. Although the glow should be faint, the current reading on the meter should be about 8 to 10 ma. If it is not, readjust R_{26} , *after shutting off the power*. The meter may now be removed from the circuit.

Before proceeding with the final adjustment of the crystal oscillator it is well to age the components for about 48 hours with the switch set for 10-Kc signals. After aging, check the multivibrators for proper synchronization. After this check, the frequency standard is ready for calibration against WWV.

The standard may be calibrated by matching the proper harmonic of its 1-Mc signal against either the 5-Mc or 10-Mc signal of WWV. It should be noted that there are a number of methods of frequency-matching more accurate than the system of eliminating an audible beat note. The method used at W2OKO was similar to that described on p. 462 of the 1955 ARRL *Radio Amateur's Handbook*. By this method (using the receiver bfo), the standard was set with ease to within less than $\frac{1}{2}$ cycle of WWV's 5-Mc signal, as noted earlier in this article.

Figure 2. Top view of chassis. A portion of the chassis deck is cut away to clear switch S_1 .

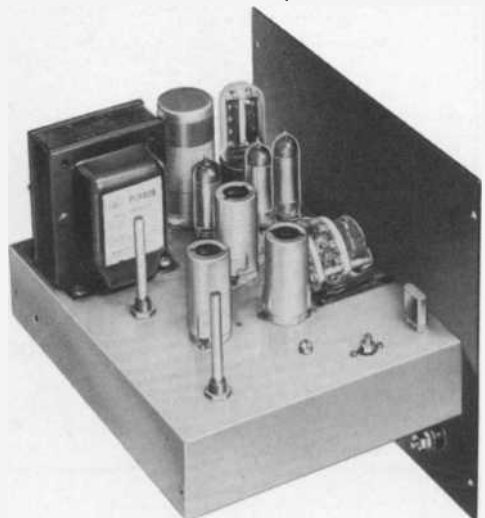

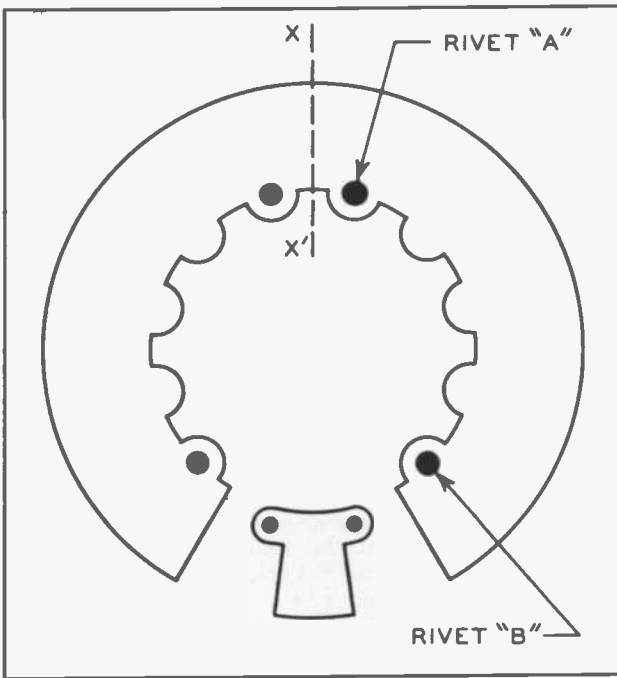
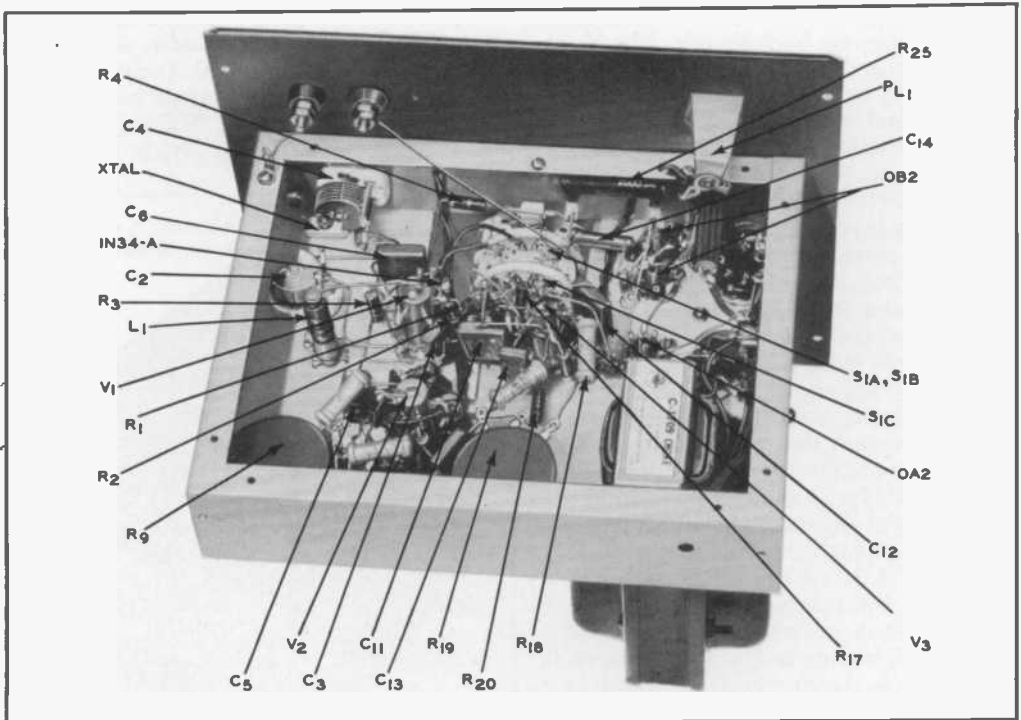

Figure 3. S1A face of switch section GG before modification. (S1B is on opposite face of this section.) Saw through switch plate along line X-X'. Drill rivet "A" until it is loose, but do not remove. Drill rivet "B" and remove. Remove portion of switch plate to right of line X-X'. Crimp rivet "A" tight again. (Rivet "A" helps secure S1B.)

Figure 4. Bottom view of chassis. Note brass slug mounted inside the coil form of L₁. The placement of components has been designed to keep heat sources away from the crystal and the 1-Mc tuned circuit (L₁, C₂); turret sockets allow neat, sturdy construction. It is suggested that the builder follow this layout as closely as possible.





From your local
RCA distributor,
headquarters for
RCA receiving
and power tubes.

RCA HAM TIPS
is published by the
RCA Tube Division,
Harrison, N. J.
It is available free
of charge from
RCA Distributors

Harvey Slavik, Editor
Charles Howard, W2QIH
Technical Editor

Copyright 1955
Radio Corporation of America

WHEN MAILING
PLACE POSTAGE HERE



FORM 3547 REQUESTED

Devices and arrangements shown or described herein may use patents of RCA or others. Information contained herein is furnished without responsibility by RCA for its use and without prejudice to RCA's patent rights.

73

...and happy
hunting
for '56