



HAM TIPS



A PUBLICATION OF THE RCA ELECTRON TUBE DIVISION

VOL. 19, NO. 2

© 1959, RADIO CORPORATION OF AMERICA

JUNE, 1959

5-BAND MOBILE TRANSMITTER

A 50-Watt Rig for Phone and CW Operation

By George D. Hanchett, W2YM

RCA Electron Tube Division, Harrison, N. J.

Did you know that a reciprocal agreement makes it possible for United States radio amateurs to operate their ham equipment in Canada—and vice versa?*

This agreement has probably inspired many hams—as it did W2YM—to include portable or mobile operation in their cross-the-border vacation plans.

The 50-watt transmitter described in this article started out to be a simple single-band mobile job for use on a Canadian fishing trip. As the design progressed, however, more and more features seemed necessary or desirable, and it finally emerged as a five-band, crystal-controlled rig for phone and CW operation on 80, 40, 20, 15, and 10 meters.

This transmitter features a bandswitching system which automatically provides the proper drive for the final on each band, and remote control of practically all operating functions from a dashboard control unit. It was designed to operate from a 12.6-volt car battery and 450-volt, 250-milliampere dynamotor. With minor modifications, as described later, the rig can be operated from dynamotors or other plate-supply sources delivering as little as 300 volts.

Figure 3 shows the circuit of the trans-

mitter. For its structural features and layout, see the photographs on pages 3 and 4, as well as the picture below.

The rf section consists of a crystal-oscillator stage using an RCA-7056, a buffer-frequency-multiplier stage using an RCA-7054, and a final stage using an RCA-6883. The modulator section includes a two-stage voltage amplifier using an RCA-7058 twin triode, and a class AB₁ output stage using RCA-7027-A's.

Recently introduced types, the 7054, 7056, and 7058 are similar, respectively, to the 12BY7A, 6CB6, and 12AX7, but specially designed for use in mobile communications equipment operating from 6-cell storage batteries. These types have heaters which operate dependably at any voltage between 12 and



*See FCC Commission Rules and Regulations, Part 12—Amateur Radio Service, Appendix 4.

15 volts and can withstand momentary excursions from 11 to 16 volts.

The 6883 is the 12.6-volt equivalent of the 6146.

The 7027-A's used in the output stage of the modulator are RCA beam power tubes designed especially for use in high-fidelity applications. They have characteristics similar to those of the 6L6-GB but with substantially higher plate-voltage and grid-No. 2 voltage ratings (600 volts and 500 volts, respectively) and higher power-output capabilities in class AB₁ service. They were selected for use in this transmitter because their high plate- and grid-No. 2-voltage ratings permitted them to be operated directly from the 450-volt supply, and because they easily provide the audio power required for 100% plate and grid-No. 2 modulation of the 6883.

Keying for CW operation is accomplished in the cathode circuit of the final amplifier.

The power-supply unit, shown schematically in Figure 1, contains the dynamotor, a filter capacitor for the 450-volt line, the relays used to open and close the main battery and dynamotor-input circuits, and fuses for these circuits.

The dashboard control unit, shown schematically in Figure 2, contains the heater- and plate-power on-off switches, a crystal-selector switch, the receiver-B+ switch and relay, and a switch used to transfer the car speaker from the broadcast receiver to the communications receiver and vice versa. It also contains a heater-circuit fuse, pilot lamps showing the condition of the heater and plate-supply circuits, and the input connectors for the microphone and key.

Circuit Details

The transmitter is designed to use 3.5-Mc crystals for 80 meters, 3.5- or 7-Mc crystals for 40 meters, and 7-Mc crystals for all other

bands. In the 80-, 40-, 20-, and 15-meter positions of the bandswitch (S₁), the oscillator output is untuned. In the 10-meter position of the bandswitch, the oscillator output is tuned to twice the crystal frequency—that is, to 14 Mc—by C₆ and L₁. The second stage, therefore, operates as an amplifier on 80 meters, as either an amplifier or a doubler on 40 meters (depending on the crystal used), as a doubler on 20 and 10 meters, and as a tripler on 15 meters.

L₂, the grid-circuit coil for the 6883, is a 2-inch length (32 turns per inch) of B & W Type 3008 Miniductor, tapped as shown in Figure 3, and is tuned by C₁₅. In the 80-meter position of the bandswitch, the total capacitance across L₂ is increased by the addition of C₁₃. The 6883 is neutralized by a bridge circuit consisting of C₁₄, RFC₄, and C₁₆, to assure good stability of the 6883 on all bands.

The plate tank for the 6883 is a conventional pi-network type using two tapped coils. L₄, the coil for the 20-, 15-, and 10-meter bands, is a 10-turn winding of No. 10 enameled copper wire, having an inside diameter of 1 inch and an overall length of 1¾ inches. L₅, which is in series with L₄ for the 80- and 40-meter bands, is an 18-turn section of B & W Type 3018 inductor. Positions of the taps on L₄ and L₅ are given in Figure 3.

L₃ is a parasitic-suppressor choke consisting of 6 turns of plastic-insulated hookup wire, about ¼ inch in diameter, and is installed directly between the plate-cap connection of the 6883 and the plate end of RFC₅.

The adjustable loading-capacitance at the output end of the pi network consists of a 140-μμf variable capacitor (C₂₆), and a group of fixed capacitors controlled by the band-switch and the "Coarse Loading" switch S₃. A 500-μμf capacitor (C₂₅) is connected in parallel with C₂₆ in the 80-meter position of

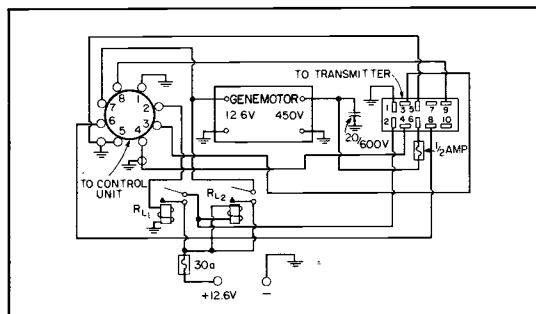

Figure 1: mobile power supply.

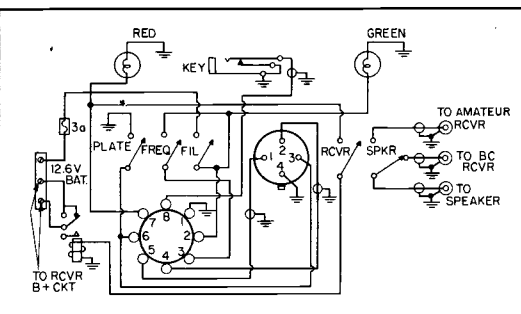
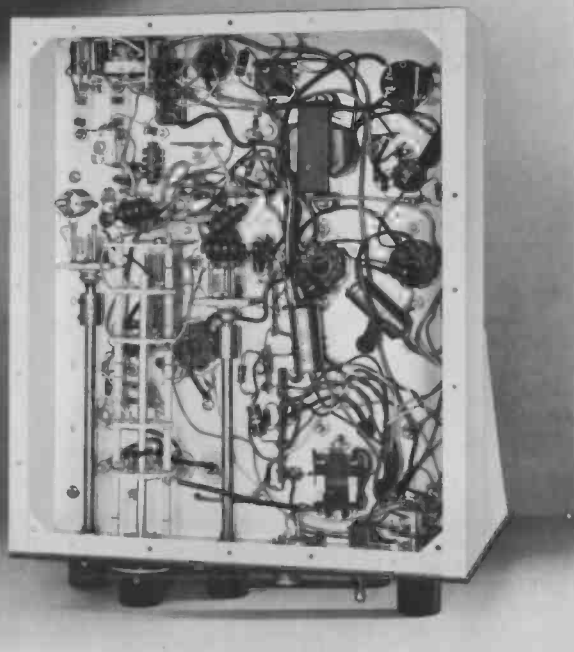

Figure 2: mobile control unit.



The microphone-cable shield is not grounded anywhere except at the socket for the 7058.

the bandswitch, and the nine 150- μ f capacitors (C_{27} through C_{35}) are successively added in parallel with C_{36} when S_3 is rotated counterclockwise.

The modest and noncritical drive requirements of the 6883 permitted the use of a simple step-type drive control ganged with the bandswitch. As shown in Figure 3, section S_{11} of the bandswitch is connected to taps on a resistive voltage-divider network across the 450-volt supply circuit, and automatically adjusts the grid-No. 2 voltage of the 7054 buffer/frequency multiplier so as to provide the proper drive for the 6883 on each band.

The voltage-divider network shown at the input to the modulator circuit in Figure 3 was designed for use with the transistorized microphone described in the September, 1956, issue of HAM TIPS. (Please note that the three-wire cable shown in this previous HAM TIPS article has been changed to a four-conductor cable. This change was made so that the ground connection for audio can be made right at the 7058 socket, thereby eliminating any possibility of ground-current pickup.) Alternate input connections for use

with a carbon microphone are also shown in Figure 3 (see inset).

To minimize the drain on the 450-volt supply under no-signal conditions, the 7027-A's are operated with somewhat higher bias than that required for true class AB₁ operation. Although this method of operation might cause severe distortion of a steady-tone modulating signal, it has relatively little effect on the quality of speech modulation

Close-up view of the bandswitch shows detail of 6883 grid coil.

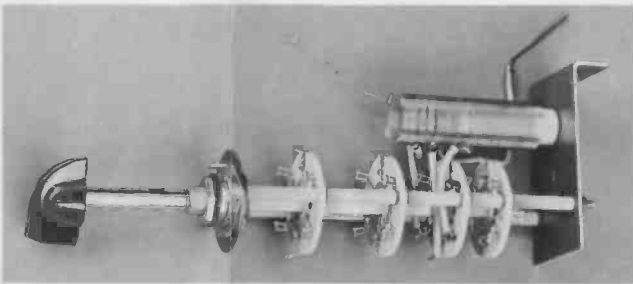

because of the very low average power of speech signals.

Changeover from phone to CW operation is accomplished by means of the "PHONE-TUNE-CW" switch (S_6). In its "TUNE" position, this switch removes grid-No. 2 voltage from the 6883 and plate and grid-No. 2 voltage from the 7027-A's, so that the oscillator and buffer/multiplier stages can be tuned without danger of damage to the final amplifier.

The meter and associated switch (S_2) are used to measure: the 7054 grid-No. 1 and plate current; the 6883 grid-No. 1, grid-No. 2, and plate currents; and the combined plate and screen currents of the 7027-A's.

Switch S_5 is mounted on the modulator gain-control potentiometer (R_{20}), and may be used to remove heater voltage from the modulator tubes when long periods of CW operation are contemplated.

Mechanical Features

The transmitter was built on a 10-inch by 12-inch by 3-inch aluminum chassis and a 10-inch by 10-inch panel. The tubes and output network of the rf section are enclosed in a 5-inch by 7-inch by 9-inch aluminum utility box.

The bandswitch (S_1), shown on page 3, was assembled from Centralab steatite wafers and spacers to permit each section to be located as near as possible to the associated stage or components. L_2 , the grid coil for the final stage, is mounted on a small standoff insulator on the bandswitch support bracket.

The taps on L_2 were made by cutting the coil stock $\frac{1}{2}$ turn beyond the desired tap point, bending back the cut ends $\frac{1}{2}$ turn, and twisting them together. The twisted leads were then soldered to make them as stiff as possible. (This procedure is repeated for

each tap, making sure that the removed turns are not counted.)

The crystal-selector switch and relay permit change of the operating frequencies directly at the operating position. If the crystals are selected so that the resulting output frequencies are separated by not more than about 0.05%, it will not be necessary to re-adjust the transmitter when shifting from one crystal to the other.



Looking at the top of W2YM's five-band mobile transmitter. Note neutralizing capacitor C_{14} mounted on small bracket and standoff insulation between 6883 and 7054.

The "DYNAMOTOR ON-OFF" switch on the transmitter panel and a local microphone connector (J_1) permit the transmitter to be operated directly at its location in the trunk compartment.

Modifications

If the transmitter is to be operated from a plate supply delivering less than 450 volts, it will be necessary to change the values of the series resistor in the plate-supply circuit for the oscillator and buffer/doubler stages (R_{22}), the grid-No. 2 resistor for the 6883 (R_{12}), and the cathode resistors for the 7027-A's (R_{32} and R_{33}). The proper values for these resistors for various plate-supply voltages are shown in Figure 3.

This transmitter has been in use for about one year and has produced very rewarding signal reports as well as some excellent DX. The reports indicate that the quality of the phone signals provided by the transistorized microphone is greatly superior to that of most mobile transmitters using conventional carbon microphones.

Figure 3: Schematic diagram and parts list of the five-band mobile transmitter. See inset for suggested speech amplifier circuit for use with carbon microphone.

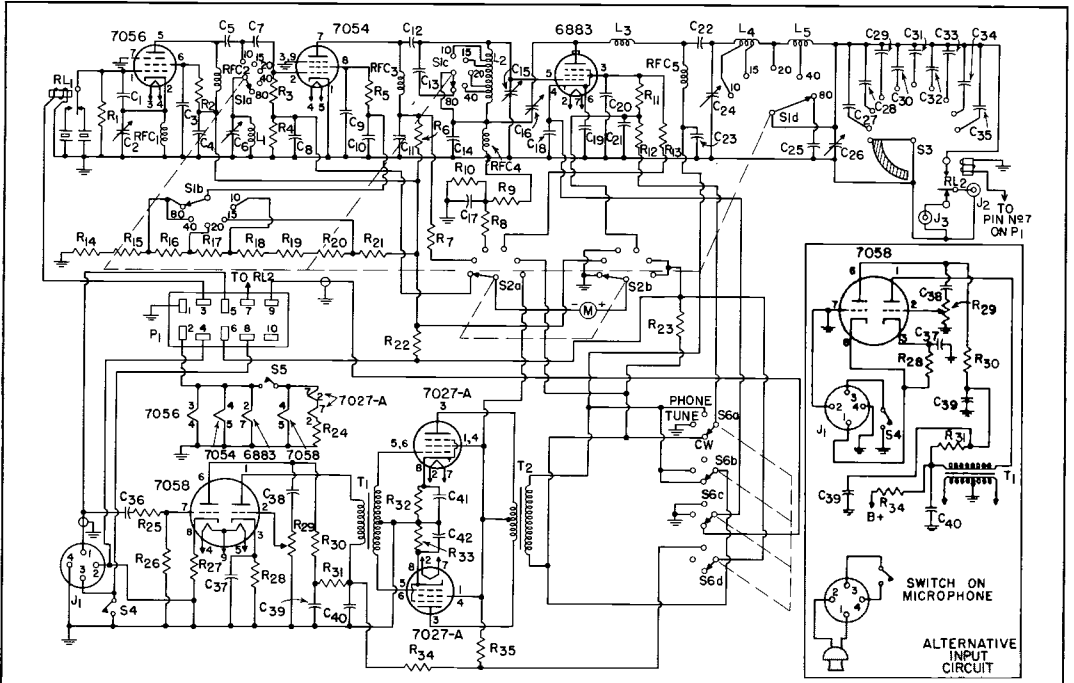

- C₁—22 μ f, mica
- C₂—80-400 μ f, compression mica
- C₃, C₄, C₈, C₉, C₁₀, C₁₁, C₁₇, C₁₈, C₁₉, C₂₀, C₂₁—.001 μ f, Disc Ceramic, 600 v
- C₅, C₇, C₁₂, C₁₈, C₁₉, C₂₀, C₂₁—.002 μ f, mica
- C₆, C₁₅—50 μ f, variable (Hammarlund HF-50 or equiv.)
- C₁₃—47 μ f, NPO Ceramic or equiv.
- C₁₄—.001 μ f (Erie Feed-Thru Ceramic or equiv.)
- C₁₆—3.5-12 μ f, tubular trimmer (Centralab or equiv.)
- C₂₂—.002 μ f, mica, 1500 v (Aerovox #1467LS or equiv.)
- C₂₃—.001 μ f, 1500 v, disc ceramic
- C₂₄—325 μ f, variable (Hammarlund MC-325-M or equiv.)
- C₂₅—500 μ f, mica
- C₂₆—140 μ f, variable (Hammarlund HF-140 or equiv.)
- C₂₇, C₂₈, C₂₉, C₃₀, C₃₁, C₃₂, C₃₃, C₃₄, C₃₅—150 μ f, mica
- C₃₆—.01 μ f, 400 v, paper
- C₃₇—10 μ f/25 v, electrolytic
- C₃₈—.005 μ f, 400 v, paper
- C₃₉, C₄₀—20 μ f/450 v, dual electrolytic
- C₄₁, C₄₂—50 μ f/50 v, electrolytic
- J₁—Amphenol #91-PC4F or equiv.
- J₂—antenna connector, coax.
- J₃—receiver-antenna connector, coax.
- L₁—12 turns B & W #3007
- L₂—57 total turns B & W #3008, tapped at 5½, 8½, 11½, and 26½ turns from grid end
- L₃—6 turns hook-up wire, ¼" diameter
- L₄—11 turns #10 enameled wire, 1" inside diameter, 1¼" long, tapped at 5½ and 8½ turns from plate end
- L₅—18 turns B & W #3018, tapped at 8 turns from L₄
- M—0-3 ma, 2"
- P₁—Jones type 300 (P310AB) or equiv.
- R₁—100,000 ohms/½ watt
- R₂—33,000 ohms/½ watt
- R₃—68,000 ohms/½ watt
- R₄, R₅, R₆, R₇, R₈, R₁₀, R₁₃, R₂₇, R₂₈—1,000 ohms/½ watt
- R₉—27,000 ohms/1 watt
- R₁₁—110 ohms/1 watt (made by connecting two 220-ohm/½-watt resistors in parallel)
- R₁₂—12,000 ohms (300 v), 18,000 ohms (350 v), 22,000 ohms (400 v), 24,000 ohms (450 v)—2 watts
- R₁₄, R₁₅, R₁₆, R₁₇, R₁₈, R₁₉, R₂₀—5,100 ohms/½ watt
- R₂₁—12,000 ohms/1 watt
- R₂₂—none (300 v), 1,200 ohms (350 v), 3,300 ohms (400 v), 4,700 ohms (450 v)—1 watt
- R₂₃, R₃₅—10 ohms/½ watt
- R₂₄—1 ohm/½ watt
- R₂₅, R₂₆, R₃₀—47,000 ohms/½ watt
- R₂₉—½ megohm/½ watt, volume control with switch (S₅)
- R₃₁, R₃₄—3,900 ohms/½ watt
- R₃₂, R₃₃—860 ohms (300 v), 1,000 ohms (350 v), 1,200 ohms (400 v), 1,500 ohms (450 v)—2 watts
- RFC₁, RFC₂, RFC₄—2.5 mh, National R-50 or equiv.
- RFC₃—1.0 mh, National R-50 or equiv.
- RFC₅—1.0 mh, National R-300 ST or equiv.
- RL₁, RL₂—12-volt dc relays, SPDT
- S₁—4 pole, 5 position (made from Centralab PA-305 index and four PA-17 stearite sections)
- S₂—2 pole, 6 position (Centralab PA-2003 or equiv.)
- S₃—single pole, 10 position, progressively opening (Centralab PA-2052 or equiv.)
- S₄—SPST, toggle
- S₅—SPST (see R₂₉)
- S₆—4 pole, 3 position (Centralab PA-2011 or equiv.)
- T₁—3-1: single plate to push-pull grids (Thordarson 20A19 or equiv.)
- T₂—10,000 ohms P to P to RF load (Thordarson 21M67 or equiv.)



From your local
RCA distributor,
headquarters for
RCA receiving
and power tubes.

RCA HAM TIPS
is published by the
RCA Electron Tube
Division, Harrison,
N. J. It is available
free of charge from
RCA distributors.

Harvey Slovik, Editor

IF IT'S ELECTRONICS
ALL BARBEY'S FIRST

GEORGE D. BARBEY CO., INC.
Reading Pottstown
Lancaster Lebanon

FORM 3547 REQUESTED

WHEN MAILING
PLACE POSTAGE HERE



Information furnished by RCA is believed to be accurate and reliable. However, no responsibility is assumed by RCA for its use, nor for any infringements of patents or other rights of

third parties which may result from its use. No license is granted by Implication or otherwise under any patent or patent rights of RCA.

25 out of the 34 transmitting-type tubes used in ARRL Handbook transmitters and modulators are High-Perveance Beam Power types.

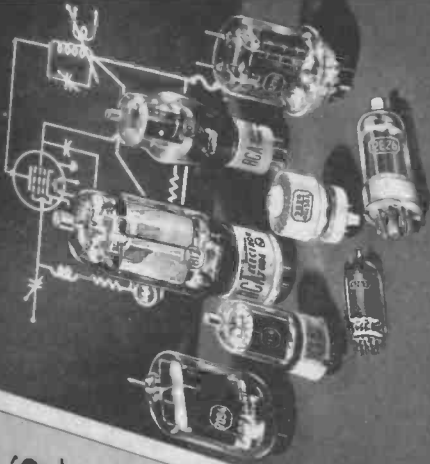

36th EDITION, 1959
**The radio
amateur's
handbook**
THE STANDARD MANUAL OF AMATEUR
RADIO COMMUNICATION

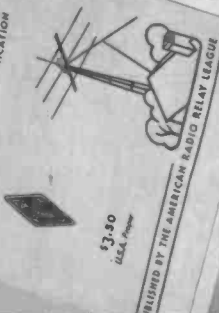

\$3.50
U.S.A. Price

1959
EDITION

..... OVER 70%
**HIGH-PERVEANCE
BEAM POWER!**

High-perveance beam power tubes—originally developed by RCA—are sweeping the field.

For example, in the 1959 Radio Amateur's Handbook, the official technical textbook of the ARRL, 21 of the 22 transmitter and modulator circuits shown employ transmitting-type power tubes.

Why do transmitter designers "standardize" on high-perveance beam power tubes?
First: Beam power makes it practicable to use smaller, less expensive drivers... fewer stages... fewer components... fewer tuning controls... simplified band-switching. Second: High-perveance design enables you to get the power you want at lower plate voltage. And you know the savings that can mean.

So whether you are rebuilding or "re-tubing," ask for RCA High-Perveance Beam Power Tubes. They're available in all amateur power ratings—from your RCA Industrial Tube Distributor.

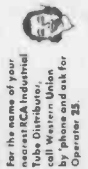

For the name of your nearest RCA Industrial Tube Distributor, call Western Union by phone and ask for Operator 23.

RADIO CORPORATION OF AMERICA
Electron Tube Division
Harrison, N. J.

