

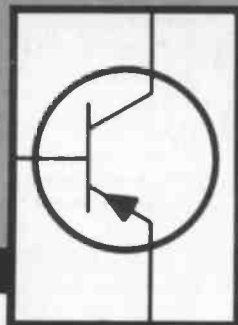

HAM TIPS



A PUBLICATION OF THE RCA ELECTRON TUBE DIVISION

VOL. 21, NO. 4

©1961, RADIO CORPORATION OF AMERICA

DECEMBER, 1961

Transistors As RF Power Amplifiers

By J. B. Fisher, WA2CMR/6
Field Sales Engineering
RCA Semiconductor and Materials Division
Somerville, N. J.

Recent advances, particularly the advent of the high-frequency "mesa" device and the use of silicon, have brought transistors to the point where they may usefully serve as drivers for high-power-output tubes, or as power stages themselves. To effect a smooth transition from tube to transistor circuit design, however, the experimenting amateur should be aware of the major differences between the two devices. Some of the important considerations for rf power amplifier design are discussed below.

Class of Operation

The transistor is a natural class C amplifier because the emitter-base contact potential must be overcome before collector current will flow. A transistor connected as shown in Figure 1 is automatically biased in the class C region. As shown by the curves of Figure 2, a positive voltage of 0.3 volt for germanium types or 0.6 volt for silicon types must be applied to the base before collector current starts to flow.

Figure 1: Transistor connected as shown is automatically biased in class C region.

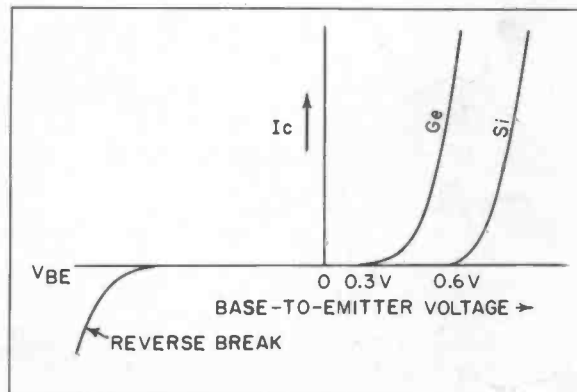
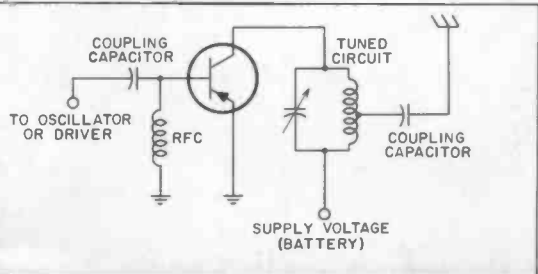

Figure 2: Before collector current will flow, a positive voltage of 0.3 volt or 0.6 volt must be respectively applied to base of germanium or silicon transistor types.

For class B operation, the transistor is forward-biased to the point where collector current just begins to flow. For class A or linear operation, additional forward bias is applied until the desired collector current is drawn.

The circuit for class A or class B operation is shown in Figure 3. The emitter resistance R_3 helps to stabilize the transistor and reduces the possibility of "thermal runaway" in the event of overheating.

"Base-leak" bias may be developed as shown in Figure 4. As base current is drawn, capacitor C charges to the voltage developed across R. If the time constant of RC is long, as compared to one cycle of the transmitted frequency, the charge is retained for this

time. This procedure requires additional driving power to the transistor, however, and does not appreciably increase efficiency.

Care must be taken to insure that the base is not driven too far in the reverse direction. Such "overdriving" could damage the transistor or cause loading of the preceding stage.

Matching

For maximum power output and gain, both the input and output of a transistor circuit should be matched. This procedure differs from tube-circuit design, in which the grid input is usually considered as a high impedance and no attempt is made to match into it.

The input impedance of grounded-emitter stages decreases with increasing power out-

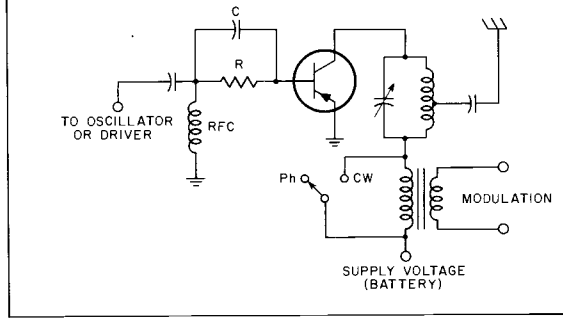

Figure 4: "Base-leak" bias and collector modulation.

[Detailed information on matching is given in the "RCA Silicon VHF Transistors Application Guide" (1CE-228). You can obtain this publication from your local RCA semiconductor distributor. It is also available for 50¢ from Commercial Engineering, RCA Semiconductor and Materials Division, Somerville, N. J.]

Efficiency

If a transistor is operated well below its alpha cutoff frequency (the frequency at which the forward current gain is 0.707 times its low-frequency value), the theoretical maximum efficiencies for its class of operation can nearly be achieved. For example, the circuit shown in Figure 5 has provided better than 90% efficiency at 50 megacycles with an output of 1 watt. Efficiencies close to 75% can be obtained in class B stages, and nearly 50% in well-designed class A stages.

Neutralization

The greatest similarity between tubes and transistors is in the area of neutralization. The feedback capacitance, sometimes referred to as $C_{b'e}$, is equivalent to grid-plate capacitance in tubes. This capacitance is the major cause of self-oscillation within the transistor.

Figure 5: Schematic of class C, grounded collector, common emitter amplifier.

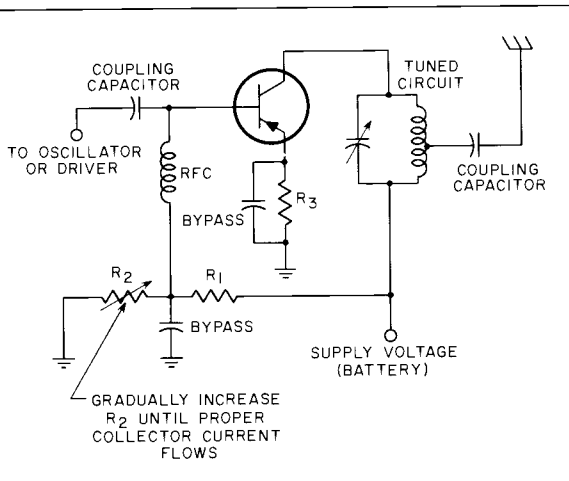

Figure 3: Schematic of class A or B amplifier.

put and is lowest for high-power transistors. Typically, this impedance ranges from 1,000 ohms in the milliwatt region to about 5 ohms for power of 1 watt or more. Grounded-base input impedance is always low, usually in the range from 100 ohms down to about 5 ohms.

Output or collector impedance R_{out} is best obtained from the power required P_{out} and the supply voltage E , as follows:

$$R_{out} = \frac{E^2}{2 P_{out}}$$

This equation is not exact, but it does provide an approximate figure for design purposes. The output is always capacitive. This capacitance is generally designated by the manufacturer as C_{ob} . The input is usually capacitive at frequencies below 50 megacycles, but may become inductive at higher frequencies.

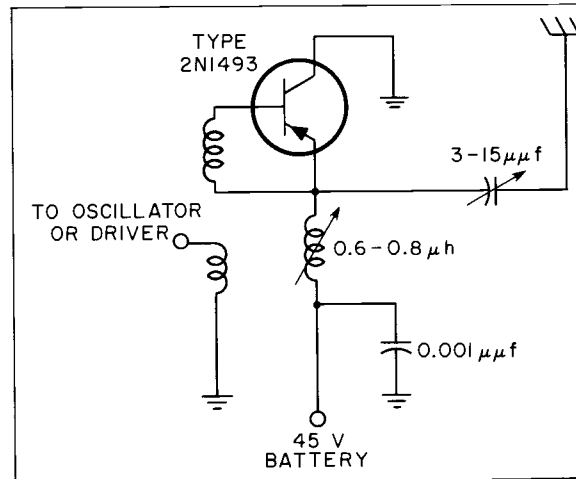

If the transistor is operated in the common-emitter configuration, this capacitance feeds back a small portion of the collector signal to the base. If this signal is sufficient to overcome base losses, the unit will oscillate. This situation is equivalent to that observed in grounded-cathode operation of triodes. In well-shielded radio-frequency amplifiers, it should be possible to operate the transistor at frequencies up to one-third to one-half its alpha cutoff frequency before neutralization is required.

The common-base configuration, like grounded-grid tube operation, is less subject to self-oscillation because the phase shift between input and output is minimized. At frequencies close to alpha cutoff, however, even this configuration should be neutralized.

Neutralization is accomplished by canceling out the effects of C_{bc} . Typical neutralization circuits are shown in Figure 6. If the transistor is operated class A, C_n may be adjusted by applying the drive to the output tank, with dc voltages on, and tuning for minimum rf at the input tank. For class C

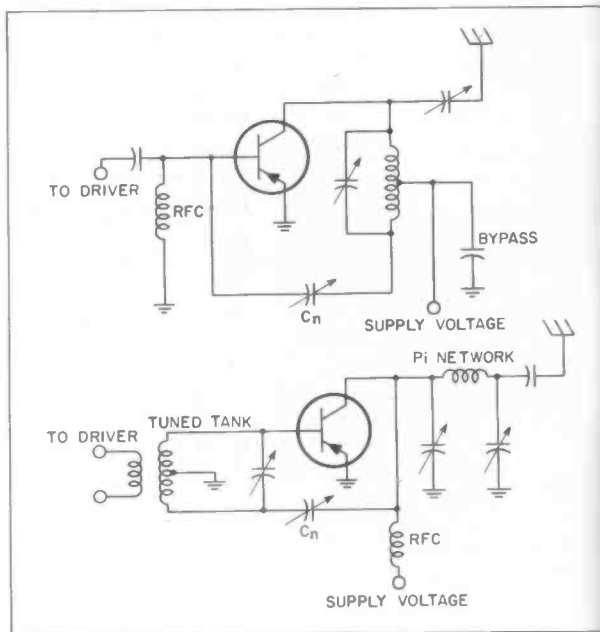

Figure 6: Typical neutralization circuits.

NEW RCA-6DS4 NUVISTOR TRIODE

Improves Two-Meter Converter

By R. M. Mendelson, W2OKO

RCA Electron Tube Division, Harrison, N. J.

Crystal-controlled VHF converters are usually designed for low noise and maximum sensitivity to improve reception of weak signals. For this reason, no provision is made for adjusting the gain of the rf amplifier.

The nuvistor two-meter converter described in HAM TIPS (May, 1961) was so designed, and the RCA-6CW4 triode amplifier was operated "wide open" at all times. With only weak signals present, this arrangement is good. However, strong local signals can cause loading of the converter and cross-modulation.

Crossmodulation can be reduced by the use of automatic gain control on the 6CW4. The newly announced RCA-6DS4 nuvistor triode, however, is much better suited for this application because of its added feature of semiremote cutoff. Because the agc voltage in a communications receiver is not developed

until a reasonably strong signal is received, the converter still has maximum sensitivity for weak signal reception.

Circuit Changes

Modification of the original converter is very simple. The new RCA-6DS4 is substituted in the same socket for the RCA-6CW4. One resistor and two capacitors are added.

As stated in the text under "Circuit Changes," to modify W2OKO's original two-meter converter, substitute an RCA-6DS4 nuvistor triode (with semiremote-cutoff characteristic) in the same socket for the RCA-6CW4 nuvistor triode, and add one resistor and two capacitors.

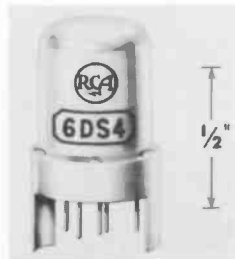

operation, C_n is made approximately equal to $C_{b'c}$, and is then adjusted for best stability of the amplifier with drive.

Heat Transfer

Heat transfer is an important problem in transistor-circuit design, although it is seldom encountered with tubes. Some means should be employed to remove heat from the transistor, especially when its maximum collector dissipation is approached. Heat transfer may be accomplished by solidly attaching or mounting the transistor case to the chassis or heat radiator. If the collector is internally tied to the case, the circuit shown in Figure 5 may be used. In this circuit, the collector is at rf and dc ground potential, although the transistor is operating in the common-emitter configuration.

Modulation

Modulation may be applied to the collector, base, or emitter of a transistor, as it may be applied to the plate, grid, or cathode of a tube. The efficiencies and percentages of modula-

tion available from each type are very similar to those available in tubes. Collector modulation is shown in Figure 4.

Power Output

The amount of power available from a transistorized transmitter is determined by the type of transistor used. There are some low-cost germanium power transistors available with reasonably high alpha cutoff (about 7.5 megacycles) that should work well on 80 meters. With a pair of these (e.g., 2N1905's at an optional list price of about \$6.00 apiece), a well-designed circuit will develop approximately 15 watts at 80 meters directly from a 12-volt storage battery. A new type now in development will put out 18 watts on 10 meters and 10 watts on 6 meters. RCA also has developmental types that will produce the maximum legal limit of 1 kilowatt on 80 meters. For the present, these types are limited in distribution and are relatively high in cost; but the amateur can look forward to their general availability in the not-too-distant future.

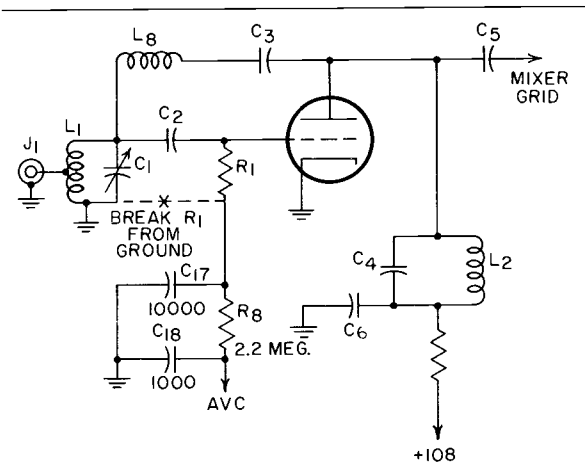

R_8 —2.2 megohms, ½ watt

C_{17} —10,000 pf ceramic disc (Centralab type DD 103 or equivalent)

C_{18} —1,000 pf ceramic disc (Centralab type DD 102 or equivalent)

The agc voltage is obtained from the communications receiver with which the converter operates.

Figure 1 shows the modification of the grid circuit of the rf amplifier. The original grid

Figure 1: Modification for AVC. (Refer to the May, 1961, issue of HAM TIPS for complete schematic diagram and parts list for W2OKO's nuvistor two-meter converter.)

resistor, R_1 , is lifted from ground and re-wired through the new R_8 to the spare contact on the Jones socket. C_{17} and R_8 are added as close to R_1 as possible, and C_{18} is added at the Jones socket.

The source of the agc voltage in the communications receiver is easily found by studying the receiver schematic and locating the agc line in the chassis wiring. The agc voltage should vary from zero at no signal to about 8 to 10 volts negative at maximum signal.

One word of caution is advisable. Some communications receivers use a fixed bias between grid and ground for the rf and if stages. If this bias is applied through the receiver agc circuit, it is always present. Thus, it would also be applied continuously to the converter and would greatly reduce its sensitivity. The receiver to be used must have zero voltage on the agc line in the absence of signals.

The effect of this simple circuit addition makes the change very worthwhile, especially in areas of strong signal reception.

BEAM POWER

For
All Powers

Whether you're on SSB, AM, or CW—QRP or QRO—there's an RCA beam power tube for every amateur transmitter power level and for frequencies to 500 Mc and beyond.

Beam power tubes make it practical to build compactness into your rig. They do the job with fewer stages, less expensive components, fewer controls. RCA beam power tubes deliver the power with relatively low plate voltages. Thousands of commercial transmitters prove out these facts.

For more usable "transmitter watts" for your dollars, "socket-up" with RCA beam power tubes. Check the chart at right for the types you need—and order direct from your RCA industrial-tube distributor.

RCA's newest beam power tube types for use in ham radio.

Popular RCA "Beam" Power Tubes for Transmitter Application (listed according to power-input ratings)								
RCA Type	Class of Service	Max. Plate Dissipation Watts		Max. Plate-Input Watts	Max. DC Plate Volts	Max. Freq. For Full Input (Mc)	Max. Useful Freq. (Mc)	Heater (H) or Filament (F) Volts
		CCS	ICAS					
5763	CW AM	12	13.5	17 15	350 300	} 50	175	6.0 (H)
6417	Same as RCA-5763, except for heater voltage							
2E26	CW SSB AM	10	13.5	40 37.5 27	600 500 500	} 125	175	6.3 (H)
2E24	Same as RCA-2E26, but has quick-heating filament							
6893	Same as RCA-2E26, except for heater voltage							12.6 (H)
832A*	CW AM	15	—	50** 36**	750 600	} 200	250	6.3▲ (H) 12.6● (H)
807	CW SSB AM	25	30	75 90 60	750 750 600			60
6524*	CW SSB AM	20	25	85** 85** 55**	600 600 500	} 100	470	6.3 (H)
6850*	Same as RCA-6524, except for heater voltage							
4604	CW	—	25	90	750	60	175	6.3 (F) quick-heating
6146	CW SSB AM	20	25	90 85 67.5	750 750 600	} 60	175	6.3 (H)
6883	Same as RCA-6146, except for heater voltage							
7203 / 4CX250B	CW SSB AM	250	—	500 500 300	2000 2000 1500	} 500	—	6.0 (H)
813	CW SSB AM	100	125	500 450 400	2250 2500 2000			
8072	CW SSB	100†	—	660 990§	2200 2200	500	500	12 to 15 (H)
8121	CW SSB	150	—	660 990§	2200 2200	500	500	13.5 (H)
8122	CW SSB	400	—	660 990§	2200 2200	500	500	13.5 (H)

*Twin-type **Total for both units ▲ For parallel-heater connection
● For series-heater connection ■ Maximum ratings for amateur use †May be higher, depending on cooling techniques § In "two-tone" operation. For a signal having a minimum peak-to-average power ratio less than 2, such as in "single-tone" operation, this value is 660 watts.

For technical data on any of these types, write RCA, Commercial Engineering, Harrison, N.J.





From your local
RCA distributor,
headquarters for
RCA receiving
and power tubes.

RCA HAM TIPS
is published by the
RCA Electron Tube
Division, Harrison,
N. J. It is available
free of charge from
RCA distributors.

Harvey Slovik, Editor

IT'S ELECTRONICS
AL. BARBEY'S FIRST

GEORGE D. BARBEY CO., INC.
Reading Pottstown
Lancaster Lebanon

BLK. RT.



Information furnished by the Radio Corporation of America is believed to be accurate and reliable. However, no responsibility is assumed by RCA for its use; nor for any in-

fringements of patents or other rights of third parties which may result from its use. No license is granted by implication or otherwise under any patent or patent rights of RCA.

RTTY

TV

*Operating Modes May Come and Go
... But The Message Will Stay Forever*

AM

SSB

FM

CW



Photo of Antique Rotary Switch Cap courtesy of ABRL

A Joyous Christmas And A Bright New Year



from the Gang at the RCA Electron Tube Division



The Most Trusted Name in Electronics