

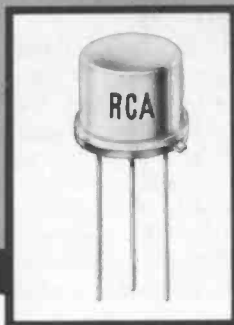

HAM TIPS



A PUBLICATION OF RCA ELECTRONIC COMPONENTS AND DEVICES

VOL. 26, NO. 4

© 1966, RADIO CORPORATION OF AMERICA

FALL, 1966

A Solid-State A-M Transmitter For Two-Meter Operation

By D. W. Nelson, WB2EGZ*

RCA Defense Electronic Products

With the advent of RCA "overlay" technology, the useful power and frequency of silicon transistors have been extended to ranges earlier thought unattainable. Today's devices can provide a minimum of 15 watts of output power at 400 MHz. Transistors that can handle 5 watts at 1 GHz should be on the market in 1967. Simultaneously, continual refinements in development and manufacturing have brought these transistors within reach of the amateur's purse. In the following article, WB2EGZ describes the use of the moderately priced RCA-40290 "overlay" transistor in conjunction with several other transistor types in a 2-meter A-M transmitter having more than 1.5 watts of output power. Over-all cost of the transistor complement is about \$20. Although WB2EGZ's transmitter design is most suitable for amateur application, and its construction poses an interesting challenge to the able craftsman, the project is not recommended for the inexperienced builder.

Circuit Description

Figure 1 shows the circuit schematic for this solid-state transmitter. The first three RF stages use silicon diffused transistors. An RCA type 40080 is used for the 72-MHz oscillator stage. The transistor for the second stage, a doubler, is an RCA type 40404 operating, in this case, class A. Although, traditionally, a doubler operates class C, the class C circuit appeared to load the oscillator too much and was unstable during variations in supply voltage. The class A circuit not only eliminates the need for a buffer stage, but provides higher output. The third stage, another 40404 transistor, operates class C as the first 144-MHz driver.

The second driver and the final stage of

this transmitter employ "overlay" transistors to provide greater gain. The RCA type 40290, which is used for both stages, is a variation of the RCA type 2N3553 particularly suited for AM systems using low voltage (12-15 volt) power supplies. The 2N3553 would be a good alternate in this circuit, but may have lower power output.

Modulation is provided by six inexpensive RCA silicon transistors in a novel circuit arrangement which has negative feedback for improved audio quality. Direct coupling of the stages improves the efficiency of the amplifier while helping to reduce its cost.

Design Considerations

In a transistorized RF amplifier, one of the greatest problems is that of obtaining an optimum power transfer from one stage to the

*Central Engineering, Camden, New Jersey

next. Because of the relatively low gain of the transistors, closer coupling is required for greater power transfer. Unfortunately, the higher efficiency associated with close coupling also results in a wider bandwidth and poorer filtering of the harmonics. Another disadvantage of a close coupling technique is the lack of a "tank" tuned circuit for dipping a Grid Dip Oscillator. Thus a compromise coupling is desirable.

A 72-MHz crystal which operates at the fifth harmonic of its basic frequency helps to reduce the number of troublesome harmonics which are present. A compromise in power was made by the use of a high-Q tank for the output of the doubler, and an inductive coupling to the first driver stage. The double tank used in the output of the final stage provides good coupling and the means of "dipping" to the correct frequency. It is also more effective in filtering the sub-harmonics which are present in this type of circuit.

In an earlier design, a 48-MHz crystal oscillator, followed by a tripler, was considered because the crystals are readily available. However, the channel-10 TV interference which resulted proved the circuit to be a poor one.

Some designers dislike the use of an overtone crystal as a frequency source in a transmitter; however, in recent years this application of the device has found wider acceptance. These crystals, which are ground flat, may be excited in the odd harmonics (3rd, 5th, 7th) of the basic frequency by the use of a high-Q circuit tuned to the desired harmonic. The principal disadvantage of an overtone crystal is the low power level at which it must be driven. If the crystal is overdriven to produce the desired output, spurious outputs at slightly higher than the desired frequency will occur. Also, a frequency shift, sometimes permanent, may result. Obviously, either condition is undesirable. However, sufficient amplification, provided by an additional amplifier, avoids these difficulties and establishes the overtone crystal oscillator as a desirable frequency/power source.

Modulation of a transistorized transmitter differs in several ways from that of the normal tube transmitter. These differences are a result of the low gain of the transistor at very high frequencies. In a transistor circuit, the RF power delivered by the driver stage to the final amplifier stage is a significant portion of the total power output of the transmitter — perhaps 10% to 20%. For this reason, 100% modulation may not be possible

without modulation of the driver stage. In higher-power transmitters, more than one driver will be modulated. Besides the advantage of higher total modulation, modulation of the driver allows it to be operated at a lower quiescent value and thereby reduces its average dissipation.

In this transmitter, the modulation is switched to the driver stage by diodes arranged so that the driver always peaks in a positive direction. This technique has been found very useful in assuring upward modulation.

Transistor Cooling Considerations

The power rating of a transistor or diode is based on the maximum safe operating temperature of the semiconductor junction. In all power applications, transistors must be properly cooled by conduction of heat away from the junctions. In this transmitter, cooling of the RF final stage is provided by a special heat sink; cooling of the modulator output transistors is effectively provided by the brass chassis. Thermal conductivity from the transistor to the heat sink is improved by the application of a thermal compound, such as silicone grease. Figure 2 illustrates how the modulator output transistors are insulated from the chassis by means of a mica spacer and two nylon feed-through washers supplied with the transistor. Although silicon semiconductors can withstand higher temperatures than germanium types, *it cannot be stressed too strongly that heat sinks and a thermal compound must be used to achieve long life in power transistors.*

Furthermore, transistors are easily destroyed by momentary overloads; *therefore, connections should be double-checked before the transistors are inserted in the sockets.* Also, remember that *transistors should never be inserted or removed when the power is on.*

If, for some reason, a stage is unstable and oscillates, the transistor may become overheated. It is wise, therefore, to keep a receiver turned on while experimenting with the transmitter. If a stage breaks into oscillation, noise will be heard over a wide band on the receiver. At this point, turn off the transmitter, correct the problem, and be sure that the transistors are reasonably cool before applying power again.

Construction

The entire transmitter is assembled on a sheet of brass measuring 5 inches by 9½ inches. This is later mounted on an inverted

5-by-9½-by-2-inch chassis as shown in Figure 3. Figures 4 and 6 show the top and bottom views, respectively, of the assembled transmitter. Although the brass sheet has been silver-plated for enhanced electrical conductivity, the transmitter should operate satisfactorily without the plating. Those who prefer to silver-plate the brass sheet can obtain a practical-type compound from Cool-Amp Company, Portland, Ore. The chassis

layout provided to full scale in Figure 5 is strongly recommended. No attempt has been made to compress the size of the transmitter. Leave the task of miniaturization to the professionals.

Transistor sockets have been used, except with the audio power units, to eliminate the danger of overheating the leads when soldering. The use of sockets also facilitates replacement of the transistors when necessary.

Although small Augat sockets were used for the author's circuit, these may be replaced by the TO-5 sockets without sacrificing efficiency. TO-5 sockets were used on the breadboard and are somewhat easier to solder.

The greatest single cause of poor transmitter efficiency is ineffective bypassing. The best bypass capacitors are feed-through types having a ferrite filtering element. An improvement over the single bypass element may

be obtained by the use of a second capacitor having a different value. Ceramic disc capacitors are effective in bypassing and have been used wherever practical to reduce cost.

Alignment

The suggested steps for alignment are as follows:

1. With the RF transistors secured in their

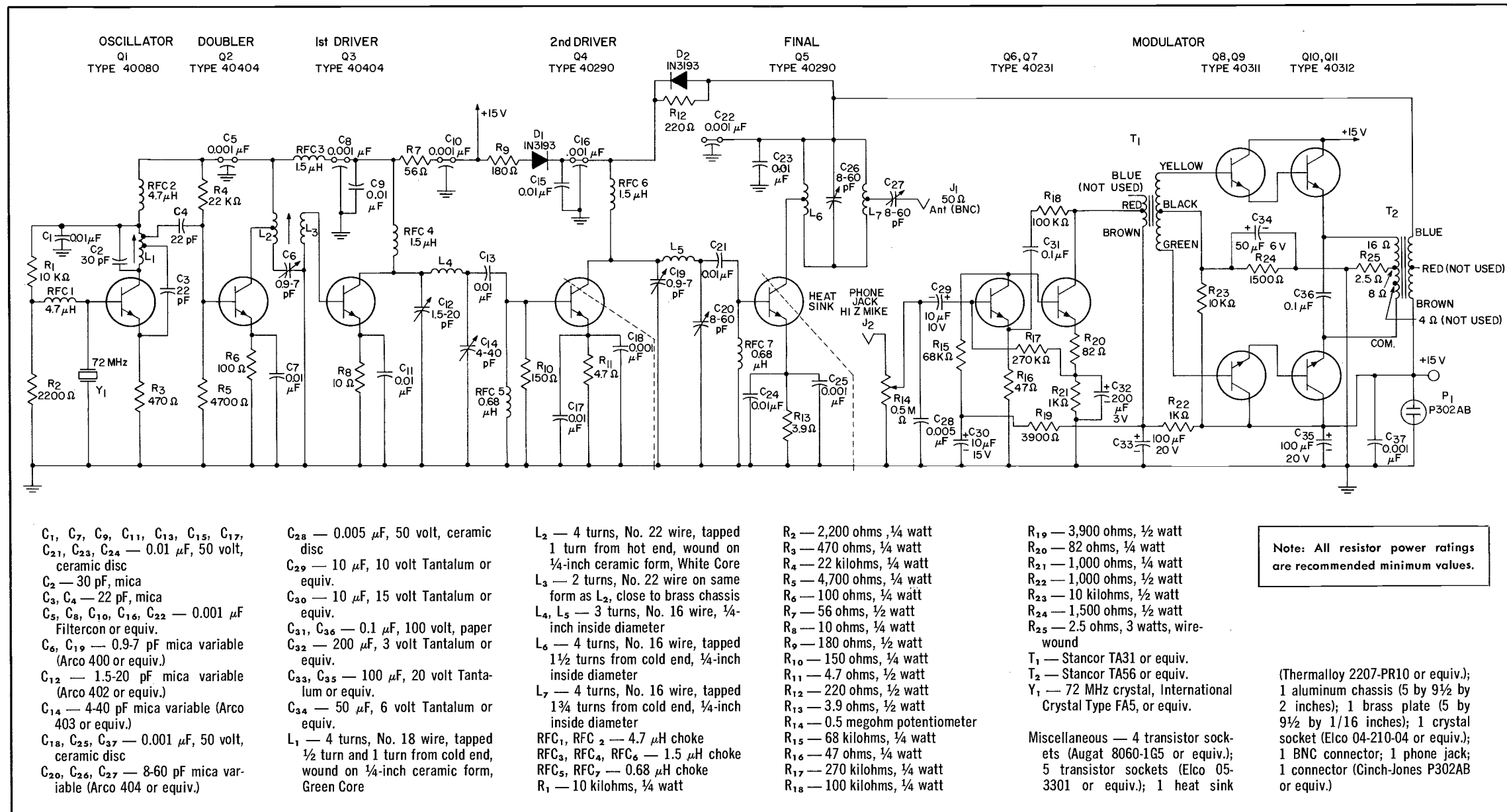

Figure 1: Schematic diagram and parts list of the WB2EGZ solid-state A-M transmitter for two-meter operation.

Note 1: 0.002-inch mica insulator
 Note 2: Remove burrs from chassis holes

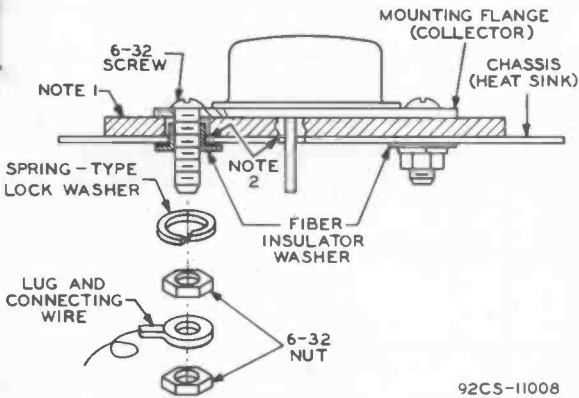

Figure 2: Method for mounting AF power transistors in the WB2EGZ solid-state transmitter.

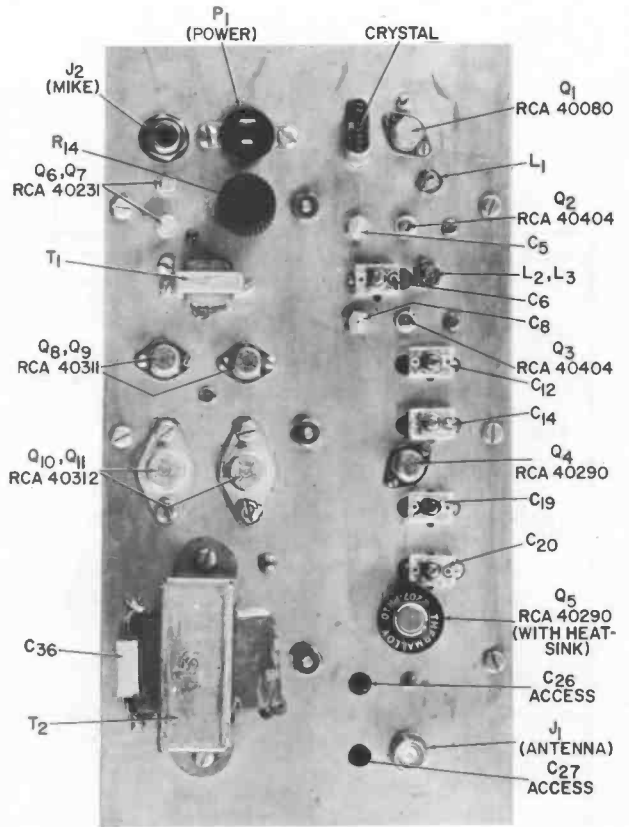

Figure 4: Top view of transmitter.

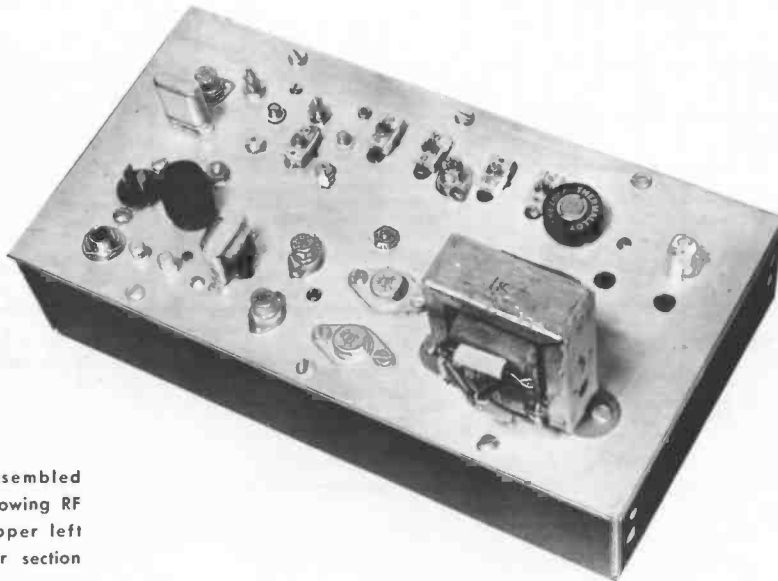

Figure 3: Assembled transmitter, showing RF section of upper left and modulator section of lower right.

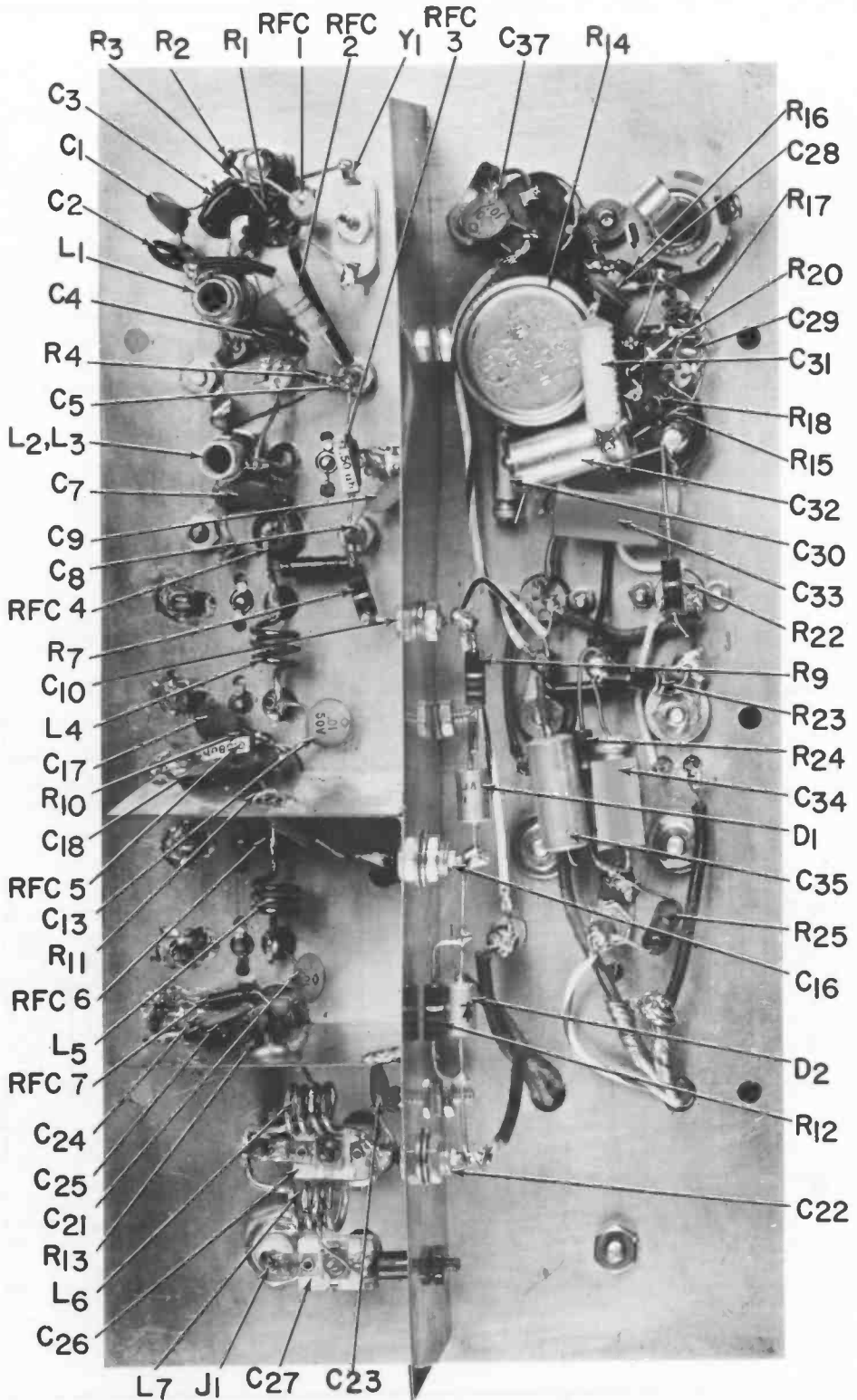

Figure 6: Bottom view of transmitter, showing RF section above and modulator section below.

sockets and the power off, tune the oscillator, doubler, and final tank circuits to their respective frequencies.

2. Remove the 40290's, apply power, and tune the first three stages for a maximum current flow by measuring the voltage drop across the 56-ohm resistor (R_7). This reading should be about 2.0 volts. At this moment, the signal heard on your receiver should be very strong.

3. Next, connect the output of the transmitter to an appropriate 50-ohm load and insert the 40290 transistors, remembering that power must be off when inserting or removing transistors. Assuming that the circuit is stable when the power is turned on, the pi networks may be tuned for maximum output. Several combinations of capacitor settings may give good output, so look for the best combinations of tuning. Retuning the oscillator and buffer may be helpful. If any stage is unstable, oscillations will be detected on the receiver. Retuning will usually correct this instability. Another indication of improper tuning (or some other difficulty) is a very abrupt change in output when tuning. It may be necessary to tune one stage at a time for maximum collector current before optimizing the power output. Unmodulated power output should be $1\frac{1}{2}$ to 2 watts.

4. Before proceeding with the alignment, proper operation of the modulator should be verified. Disconnect the RF side of the modulation transformer and connect a 100-ohm, 1-watt resistor across it. Using an oscilloscope and an audio generator, check the waveform for a 28-V p-p output without distortion. If clipping or distortion occurs at this level, the bias voltage for the power stage should be adjusted for the best sinusoidal pattern by changing the value of R_{24} .

To tune the transmitter for best modulation, it is necessary to monitor the signal with an oscilloscope. One way to accomplish this is by using the technique employed by W2GQK ("RF 'Sample-Box' for 'Scope Monitoring of Amateur Transmitter Output" — HAM TIPS, Vol. 26, No. 3, Summer, 1966). As the latter method appeared subsequent to the author's completion of the transmitter, the technique used in this instance was to connect the vertical input of the 'scope across the output of the final IF stage in the receiver (see Figure 7). The RF envelope of the transmitter may now be viewed.

5. With the modulator connected to the transmitter, apply power. Use a test tone, at

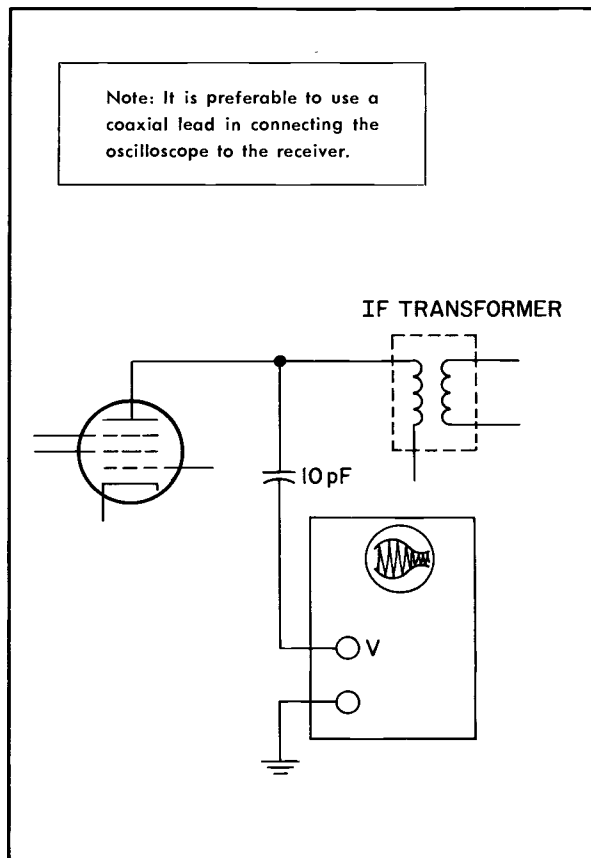

Figure 7: Schematic diagram showing method used by W2EGZ to connect the signal from the transmitter to an oscilloscope.

1 kHz for example, to modulate the carrier at some level below 30%. If distortion is observed in the envelope, adjust the final tank circuit and input capacitors slightly. Now the modulation may be increased to a greater value, such as 50%, and the envelope rechecked for distortion and upward modulation. Repeat the procedure until an 80% modulation level is achieved.

Caution: At this modulation level, adjustments in tuning should be made very carefully because it is extremely easy to detune the circuit far enough to exceed the ratings of the transistor. As a precaution, the modulation level should not be advanced to 100% during tone tests.

If the average power output decreases as the modulation is increased (downward modulation), detune L_2 until upward modulation results. When the other circuits are properly retuned, the average output will be almost as

RCA HAM TIPS is published by RCA Electronic Components and Devices, Harrison, N. J. It is available free of charge from participating RCA Industrial Distributors. It is also available on a two-year subscription basis (\$1 for eight issues to cover costs of handling and mailing). Please make check or money order payable to Radio Corporation of America, and remit to "Radio Corporation of America, Section 882, Harrison, N. J. 07029."

Information furnished by the Radio Corporation of America is believed to be accurate and reliable. However, no responsibility is assumed by RCA for its use; nor for any in-

fringements of patents or other rights of third parties which may result from its use. No license is granted by implication or otherwise under any patent or patent rights of RCA.

great as the original unmodulated carrier. During alignment, care must be exercised to prevent overheating the transistors. After correct alignment, none of the transistors should be too hot to touch.

Although precise linearity is best determined using a trapezoidal pattern on the monitor scope, the author obtained good results by observing the RF envelope and listening for distortion in the tone. If sidebands are wide, slight tuning readjustments will help correct the wave form. Some broadness may be expected because the driver is modulated and because the output capacitance changes when a transistor is modulated. Before going on the air, set the modulation level to peak at 90% with the microphone to be used.

"On the Air"

Most hams contacted by the author have been surprised that transistors could be used to generate a signal on 2 meters so effectively and so inexpensively. In one band opening, a good contact was made with a station located 185 miles away. The power output averages 1.5 watts when using a 15-volt supply. Power consumption at this level is about 8 watts — a lot less than it takes to light the heaters of the smallest tube rig. Although operation of the transmitter from a 12-volt source is possible, the power output will be reduced. Should you desire to operate the

transmitter using a power supply having wide variations of output voltage, it is advisable that you tune the transmitter using the lowest supply voltage. Direct operation from an automobile supply would not be practical without providing some means of regulation within the transmitter.

Care in the construction of a transistorized transmitter — as well as extreme patience in its alignment — are the keys to success. The rewards are a great feeling of pride and countless hours of trouble-free operation.

Acknowledgment: As with all projects of similar magnitude, the suggestions and experience of many people have been carefully integrated to make this transmitter a prime example of "results through cooperation." To George Hanchett, W2YM, go special credits for his aid in bringing costs "into line". The author is likewise indebted to Stan Matyckas, WB2IXE, for his contributions to the modulation techniques used. Some other useful references were as follows:

Adley, David L., "Designing 160-MHz FM/CW Solid-State Circuitry," Motorola Applications Note AN/68.

Alexander, Wilson E., "4W-200Mc Transistor Amplifier," Fairchild Application Data APP92, November, 1963.

Belke, R. E., Cleary, J. F., et al, "GE Transistor Manual," 7th Edition, 1964, pp 241-258.

Matyckas, S. J., "Design of an Amplitude-Modulated VHF Transmitter Using the RCA TA2267," RCA Application Note SMA-10.

Rheinfelder, W. A., "Modulation of Driver Stage to Increase Power Output of A-M Transmitter," "Semiconductor Products," March, 1962.