



# Bell Laboratories Record

---

*Volume Seven*

AUGUST, 1929

*Number Twelve*

---

## The Story of Short-Wave Transoceanic Telephony

By A. A. OSWALD  
*Research Department*

THE year 1924 brought forth the conclusion that the results of two years of previous work on short waves justified an active interest in the problems of short wave operation on a large scale. Orders to build at Lawrenceville, New Jersey, came in 1928; 1929 sees the station in operation. The development and installation of the United States terminals for the four new transoceanic radio-telephone channels is a splendid example of cooperation in research and engineering. Extending over a half-decade, the project which culminates in the stations at Lawrenceville and Netcong, New Jersey, and their counterparts in England involved the work of several score of engineers, scientists and others. By tracing the history of the work, there may be given a new impression of its magnitude; by mentioning some of the men who contributed, an idea may be conveyed of the variety of talents required for its success.

Until the latest stages of this work

brought its problems of systems development, short-wave investigation was confined to groups working at first under H. W. Nichols and after his death under W. Wilson. Late in 1921 R. A. Heising and J. F. Farrington began a study of methods of generating and receiving radio signals with high frequencies and measuring the intensities of their fields. These investigations dealt with comparatively low powers, not exceeding about 200 watts; so successful were they that the design of higher-powered equipment was initiated. J. C. Schelleng and E. B. Ferrell, working on short-wave transmitters, developed power amplifiers, for association with Mr. Heising's high-frequency oscillators, to the point of putting from three to five kilowatts into the transmitting antennas. J. C. Gabriel and G. Thurston, under the direction of Mr. Farrington, further developed the generating and modulating circuits and added crystal control. With the added power field-strength measurements



*Engineers in charge of the development of the short-wave radio transmitters and receivers. Left to right: A. A. Oswald, M. J. Kelly, W. Wilson, R. A. Heising, J. C. Schelleng, H. T. Friis*

were made on several wavelengths at distances up to a thousand miles in various directions. Meanwhile H. T. Friis and E. Bruce concerned themselves with short-wave reception, and devised suitable antenna systems, receivers, and field-strength measuring equipment.

A further simultaneous survey of field strengths at great distances over a wide area was then made; using the various portable measuring sets that had been developed, men from the Laboratories and the American Telephone and Telegraph Company made observations on signals from Deal at numerous distant posts. Participants in this experiment were: C. R. Englund, F. B. Llewellyn, and F. H. Willis (A. T. & T.), first at Cleveland and later at Chicago; J. G. Chaffee, E. J. Sterba, and S. Wright, first at Minneapolis and later at Dickinson, North Dakota; J. F. Farrington, E. G. Ports, and E. A. Krauth, first at

Shelby, Montana, and later at Seattle; C. V. Litton, H. C. Baumann, and G. M. Eberhardt, on a truck moving from fifty to three-hundred miles west of New York; F. R. Lack, G. Thurston, and G. Southworth (A. T. & T.), on the steamship "Republic" bound for Bremen; E. Bruce, F. A. Hubbard, and G. D. Gillett (A. T. & T.), on the steamship "Minnewaska" bound for London; and A. G. Jensen, at New Southgate, England. Between Deal and New Southgate, where Mr. Jensen has been assisted by English engineers, these observations have continued up to the present.

The good results of the tests warranted a commercial trial; in 1927 the Deal transmitter was associated with the New Southgate receiver as an eastbound short-wave experimental channel, auxiliary to the long-wave system which was by that time in full commercial operation. During that summer it could always be used in

combination with the long-wave west-bound channel, and, indeed, it was in use more than half the time, under the direction of N. F. Schlaack. This operation clearly demonstrated the complementary properties of long-wave and short-wave systems. Of the two major hazards to good radio transmission, static and magnetic "storms", the long-wave system proved adversely affected by the former and comparatively little affected by the latter, whereas the short-wave system showed the reverse properties.

So ended the initial experimental stage of the development, the stage in which the fundamental circuits were determined. The design of a first commercial transmitter was next undertaken by the late H. R. Knettles, under the supervision of the writer and assisted in the mechanical design by J.

L. Mathison. E. J. Sterba and E. B. Ferrell worked at Deal on directive transmitting antennas; Messrs. Friis, Bruce and R. S. Ohl continued at Cliffwood their work on directive receiving antennas and other receiving problems. The first transmitter designed with commercial operation in view was installed at Deal, and at Cliffwood a receiver was built by H. C. Baumann to serve as a model for later commercial design.

The success of the short-wave development and the increase in transatlantic traffic over the long-wave system combined to decide the American Telephone and Telegraph Company and the British Post Office to establish a complete two-way short-wave channel, to be opened June 1, 1928. To a site purchased at Netcong the Cliffwood receiver was accordingly

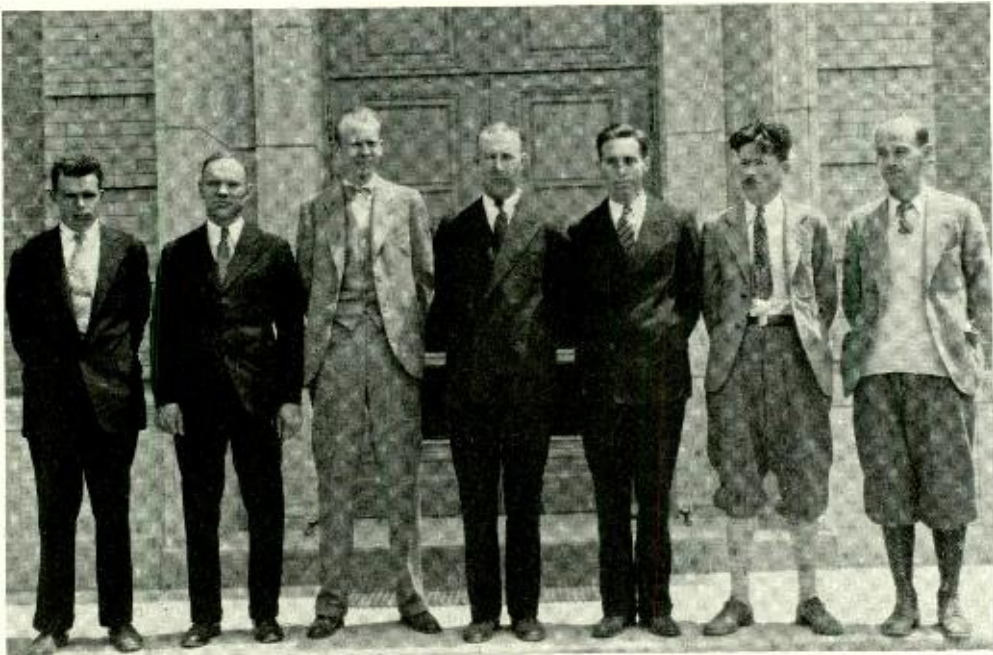

*Engineers associated with the development of the radio transmitters, on the steps of the main building at Lawrenceville. Left to right: E. B. Ferrell, F. F. Merriam, A. Oxehufwud, N. F. Schlaack, C. F. P. Rose, N. E. Sowers, E. J. Sterba*



*Engineers associated with the development of the radio receivers. Left to right: F. A. Hubbard, F. A. Polkinghorn, J. C. Gabriel, J. L. Mathison*

moved by E. J. Howard and L. R. Lowry, for use in association with the transmitter at Deal. Systems groups,\* which had designed wire-line equipment for the long-wave channel, installed at Deal, Netcong, and Walker Street the necessary additional equipment, incorporating improvements made in the meantime, and the channel went into service at the time scheduled.

But use of the transatlantic service was increasing so rapidly that the American Telephone and Telegraph Company found that more channels and facilities independent of those at Deal would be necessary to handle the business. Ordering in May, 1928, a channel to replace Deal, and two more to England and one to South America, the American

\* BELL LABORATORIES RECORD, April, 1926, page 44.

Company purchased in August a transmitting site at Lawrenceville and scheduled the opening of the first transmitter for June 1, 1929. The intensive work necessary to meet this date was immediately started by these Laboratories and the Long Lines Department. Mr. Schelleng continued circuit studies toward further improvement of the transmitters, and Mr. Friis of the receivers; the coordination of the group activities of the Laboratories, and the design and layout of the apparatus

and stations, were the responsibility of the writer.

M. E. Fultz, C. F. P. Rose and A. Oxehufwud, assisted by J. L. Mathison, redesigned the transmitter in accordance with experience gained at Deal and incorporated crystal-oscillator systems based on the work of F. R. Lack. N. F. Schlaack and E. B.



*The Laboratories' short-wave receiving laboratory at New Southgate, England, where A. G. Jensen (right) is assisted by R. Hamilton and other British engineers*

Ferrell set up and tried out at Deal all doubtful features of the new design. M. E. Fultz and F. F. Merriam, in cooperation with the American Company's architects, prepared the station plans, including the safety system and other operating features. In September the Long Lines Department broke ground at Lawrenceville, and by January the station was sufficiently advanced to permit installation of the power equipment. Technical supervision of its installation and test was given by Messrs. Oxehufwud and Rose, assisted by B. H. Nordstrom, and by T. J. Crowe, experienced as foreman of the Plant

Department's electricians. Messrs. Ferrell and Rose, and N. E. Sowers, conducted tests and adjustments on the radio apparatus. Messrs. Sterba and Merriam, assisted by G. M. Eber-

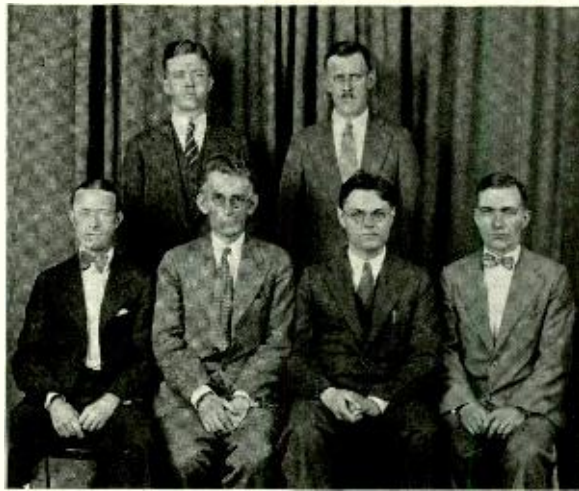

*Engineers associated with the development of the wire-line terminal equipment. Left to right: front, W. F. Malone, C. C. Munro, F. L. Morgan, H. M. Pruden; back, P. V. Koos, H. H. Spencer*

hardt and P. H. Smith, designed the antennas and transmission lines and gave technical supervision to the Long Lines crews which erected and tested them. Work extended to holidays and

artificially illuminated nights. Tracings taken in late evening from drafting boards under Mr. Mathison's supervision at West Street were rushed to Lawrenceville to guide the following morning's work.

Meanwhile F. A. Polkinghorn, with the assistance of F. A. Hubbard, J. C. Gabriel, E. G. Ports, J. L. Mathison and H. L. Holley, supervised the design and construction of a receiver based on a model constructed and tested in the Laboratories. This model incorporated many new features of commercial form but embodied substantially the fundamental circuits previously determined by Mr. Friis and



*Engineers in charge of the development of the wire-line terminal equipment. Left to right: front, D. C. Meyer, E. J. Johnson, R. H. Kreider, E. Vroom; back, K. M. Fetzner, J. E. Cassidy, E. D. Johnson, J. L. Larew*

his group at Cliffwood. The set, wired at West Street by A. C. Chaiclin and tested there by Messrs. Gabriel and Hubbard with the assistance of A. Hartmann and D. M. Black, was finally installed at Netcong by Messrs. Hubbard and Black, who then gave it further tests with the cooperation of the Department of Development and Research. Mr. Bruce, assisted by L. R. Lowry, R. M. Whitmer and F. Giovanini, gave technical supervision to the erection of the receiving antennas by Long Lines crews; tested the antennas; and substituted, for the open-wire transmission lines previously used, the concentric-pipe transmission lines developed by C. B. H. Feldman at Cliffwood.

At transmitting, receiving, and control stations, the work of the Systems Development Department on voice-frequency equipment was meanwhile being completed. E. D. Johnson, of R. S. Wilbur's group, prepared the circuits for line-terminal audio-opera-

tion and testing, with the assistance of E. Vroom, C. C. Munro, and H. M. Pruden; and J. A. Coy, working under D. C. Meyer, made general layouts of the necessary equipment. Detailed engineering of equipment, and its installation, was then undertaken by E. J. Johnson's group. Under J. L. Larew the wire-terminal power plant for Lawrenceville was designed and tested by H. H. Spencer, and for Netcong and Walker Street by R. P. Jutson. All other telephone equipment became the concern of R. H. Kreider, under whom J. E. Cassidy and P. V. Koos designed and installed equipment at Lawrenceville, W. H. Bendorf and F. L. Morgan at Netcong, and R. B. Simon, W. F. Malone, J. D. Nedelka, F. A. MacMaster, J. N. Loomis and E. A. Bescherer at Walker Street. This work was complete when E. D. Johnson's group returned to test its circuits in their actual physical embodiment and announced them satisfactory.

Contributions from other groups were too numerous for complete mention. Of special interest are a band-pass filter, to operate at an intermediate radio frequency of about four hundred kilocycles, from C. E. Lane and his men; and a new differential relay from J. R. Fry's group. In the vacuum-tube laboratory directed by M. J. Kelly, special tubes for receiving circuits, including new shield-grid types, were developed by H. A. Pidgeon and J. O. McNally, and new power tubes for the transmitters were developed to meet high-frequency requirements by H. E. Mendenhall, V. L. Ronci and C. E. Fay.

Throughout all the development, moreover, the unfailing support, extending to overtime work, of the Plant and Commercial Departments



*Engineers associated with the development of short-wave vacuum tubes. Left to right: front, H. A. Pidgeon, V. L. Ronci; back, H. E. Mendenhall, J. O. McNally*



*J. A. Coy*



*F. R. Lack*



*E. Bruce*

was indispensable. In a special shop in 4-K, F. Berger took charge of building the transmitting and receiving sets. By arrangement with B. B. Webb's group, maximum assistance in the commercial phases of the work was secured. W. F. Johnson, assisted by H. W. Dippel and R. W. Mutchler, arranged for the purchase and delivery of the necessary materials from suppliers. Under K. B. Doherty, J. F. Lewis handled estimates, case-authorization, ordering and billing; and G. F. Doppel the manifold problems of scheduling and production, with the assistance of C. W. Stevens and H. S. Enger at West Street and P. May at Lawrenceville. C. Deyo took charge

of storage, and of export to South America.

On June 1 as scheduled a year before, the first transmitter at Lawrenceville was cut into operation, and commercial service was initiated by a call from Cleveland to London. A week later the new channel was reported by the Long Lines Department as giving substantially better service than either of its predecessors. The second channel, replacing Deal, will be opened on September 1, and the third on December 1. Service to South America, where E. J. Howard is now making transmission observations on signals from Deal, opens next February.

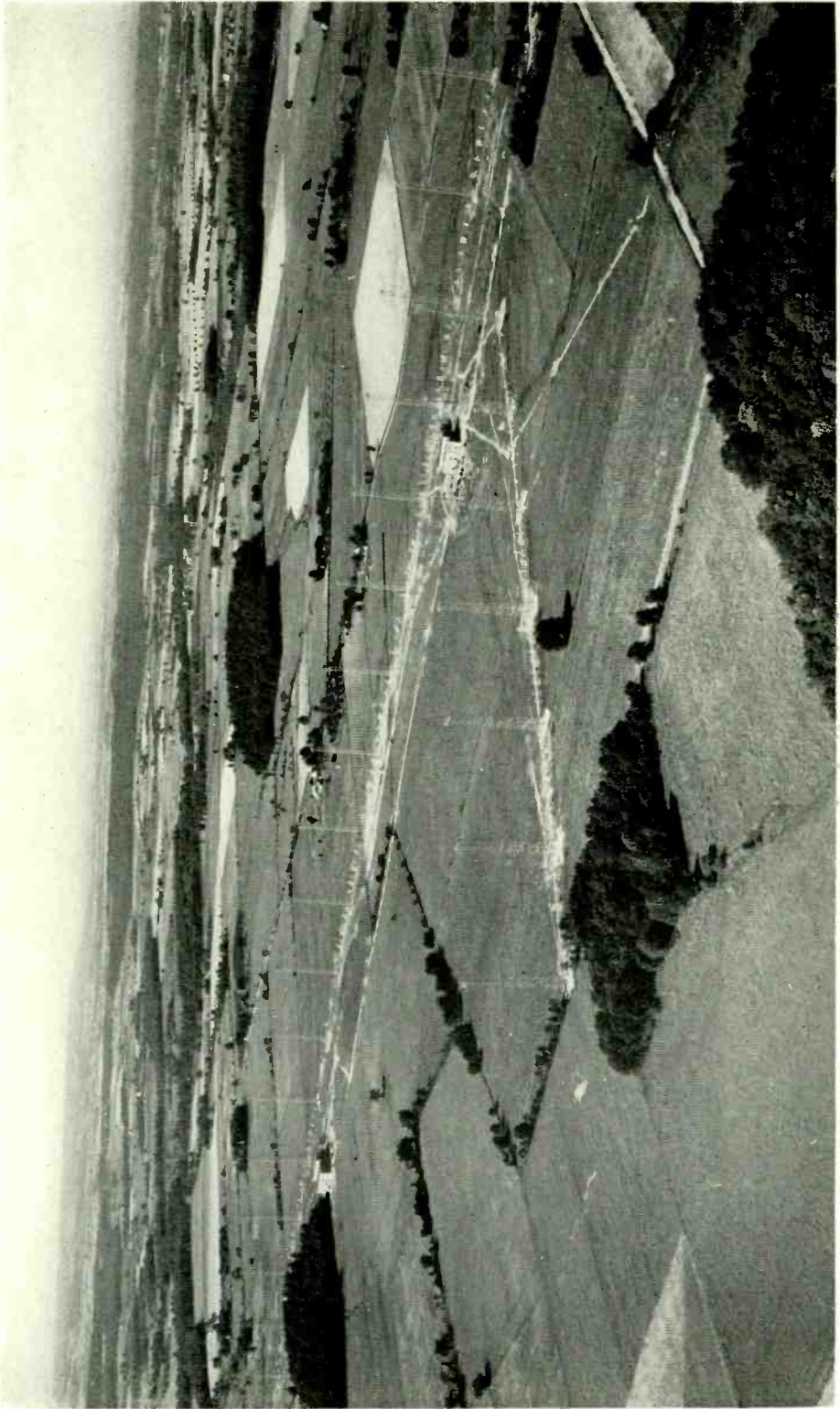

Fairchild Aerial Surveys, Inc.

*General view of the grounds at Lawrenceville*





# Transmitting Station at Lawrenceville, N. J.

By M. E. FULTZ  
*Research Department*

---

AT the request of the American Telephone and Telegraph Company, the problem of planning a four-channel short-wave radio transmitting station, for commercial telephone service to Europe and South America, was undertaken in the spring of 1928. The selection of transmitting frequencies, circuits and antennas to be used, was based upon experience with the installation at Deal and the development work conducted at that station during the previous two years.

Due to the particular type of antenna selected, and the fact that each transmitter was to operate on any one of three assigned frequencies, a total of twelve independent antennas for the four channels was necessary, each requiring a linear distance of 500 feet for its structure. These antennas have directional characteristics which necessitate placing them broadside to the direction in which transmission is desired. Since it was not considered advisable to place obstructions directly in front of any antenna, straight line formations were selected. With this arrangement, an extremely long line of towers results when several channels transmit in the same direction. This is the case at Lawrenceville, N. J., where three of the four transmitters work to England.

The space requirements for a single antenna were arrived at on the basis of a fixed linear distance be-

tween towers which would most satisfactorily accommodate any one of the three antennas. This was done so that all tower spacings would be uniform and flexibility obtained for shifting groups or interchanging the antennas in a group in case it was later found desirable to make such changes.

In order to avoid undue loss in the transmission lines feeding these antennas, each transmitter should be located as nearly central to its three antennas as possible. It was, therefore, decided to separate the four transmitters and install not more than two in a single building. Accordingly two two-story buildings identical in layout, insofar as the transmitter installations are concerned, were erected by the American Telephone and Telegraph Company.

On the ground floor of each building, occupying the entire width at the rear, are transformer vaults and rooms for water-cooling units. Directly in front of these and also extending the full width of the building is the power room, a general view of which is shown in Figure 1. There are three motor-generator sets to a group for supplying power to the various units of one transmitter, and three such groups located in this room. The left and right hand groups are the regular machines for the two transmitters, while those of the middle group serve as spares for either. Between each group of machines, in a

screened enclosure, is located a transfer switch unit. It consists of three groups of double-throw gang-operated switches, which, when thrown in the proper direction, substitute entire spare motor-generator sets, including their automatic starting compensators, for the corresponding regular units associated with a transmitter. An interlocking system prevents the simultaneous use of a spare motor-generator set on two channels.

On the right hand side of the room is a standard twenty-four-volt power plant to meet the requirements of the telephone line-terminal equipment. On the left, between the first two automatic starting compensators, one of the generator noise filters is visible. This particular filter, the coil of which has a current-carrying capacity of six hundred amperes, is used in the supply line to the filaments of the transmitter tubes. Water pumps, water stor-

age tanks, and a motor-generator set for sleet-melting, are also located in the power room.

As a precaution against vibration in the building, all rotating machinery was mounted on concrete piers which rest on cork mats several feet below the power room floor. Cork linings surround these piers where they pass through the floor.

Directly over the power room and of equal floor area is the transmitter room (Figure 2). Here are located two transmitters, in line, on one side of the room and two power-control boards, in line, on the other. A transmitter and its power-control board face each other with a seven foot aisle between them. Associated with each transmitter is an audio-frequency control turret, located on a desk which stands in this aisle near the center of the room. The radio operator, in this position, can communicate directly

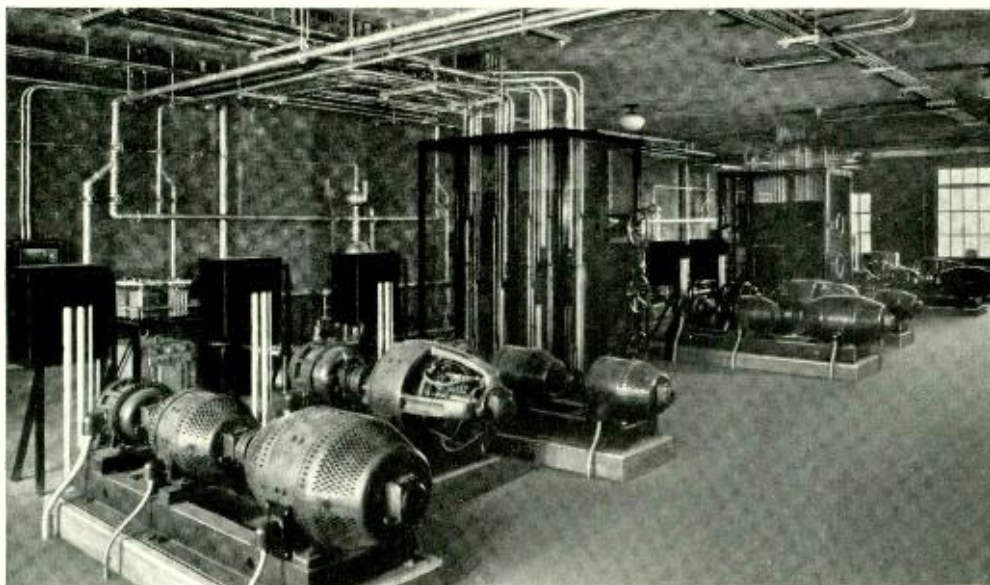

*Fig. 1—General view of power room, showing the three groups of motor-generators (the center one a spare) for supplying the power to the transmitters, and the two screened transfer switch units*

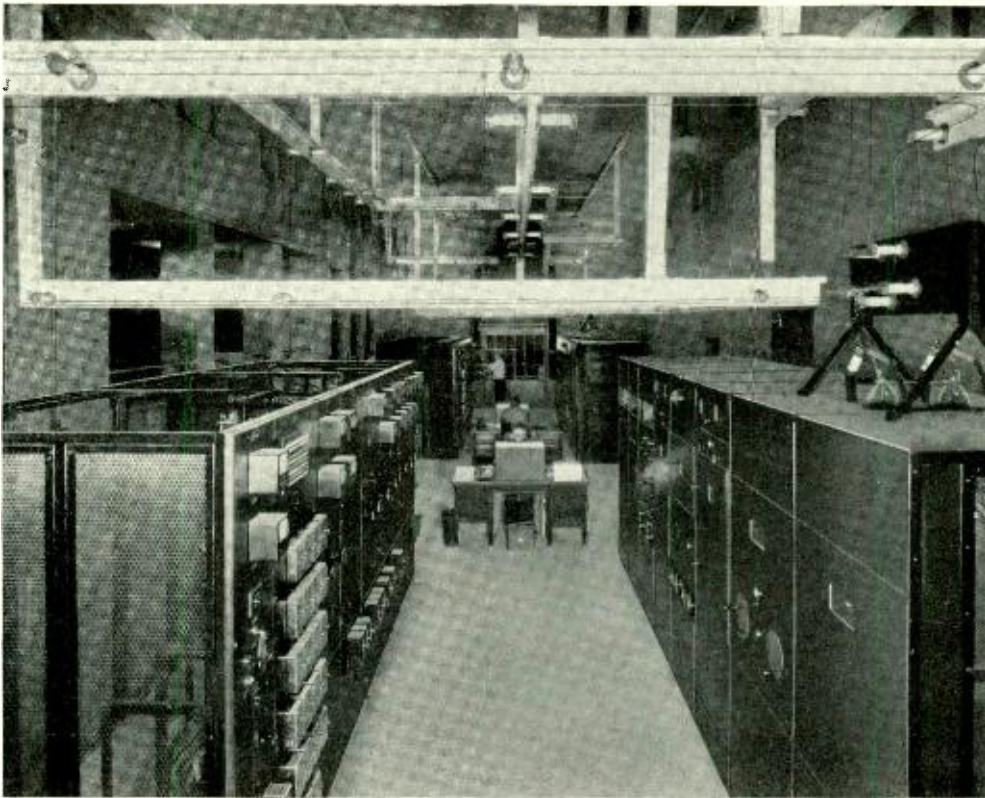

*Fig. 2—General view of transmitting room. Left, power boards; right, transmitters; center, monitoring desks; left center room, rectifiers*

with the New York control operator and monitor the input and output of the radio transmitter.

Extending back over the top of the middle transformer vault from the center of the room, and at a slightly higher floor level, is a room containing two six-phase high-voltage rectifiers (Figure 3), for supplying direct current to their respective transmitters. Beneath the rectifiers, on each side of the middle transformer vault, is a high-voltage switch chamber. Each contains a double-throw 25,000-volt switch by means of which either rectifier can be transferred from its regular transformer to a common spare. The transfer not only involves substituting a transformer but also

all other equipment located in a transformer vault. In addition, therefore, to the eight high-voltage connections, provision is made for changing control circuits and the connections to certain protective features by mechanically connecting a twelve-pole double-throw switch to the high-voltage switch. With this arrangement a complete substitution of transformer-vault equipment is possible by operating a single switch handle in the transmitter room (Figure 4).

The equipment comprising each transmitter proper is contained in seven independently shielded units mounted side by side on a common sub-base. Three of the units are devoted to input equipment and the

other four to power amplifiers and their associated circuits.

The power-control board (Figure 5) consists of motor-generator control-panels and distribution panels, nine in all, equipped with the necessary apparatus for controlling and applying power to the associated transmitter. All apparatus is remotely controlled from this point. Independent control of the various motor-generator sets may be had from their respective panels and power applied to the transmitter by working in the

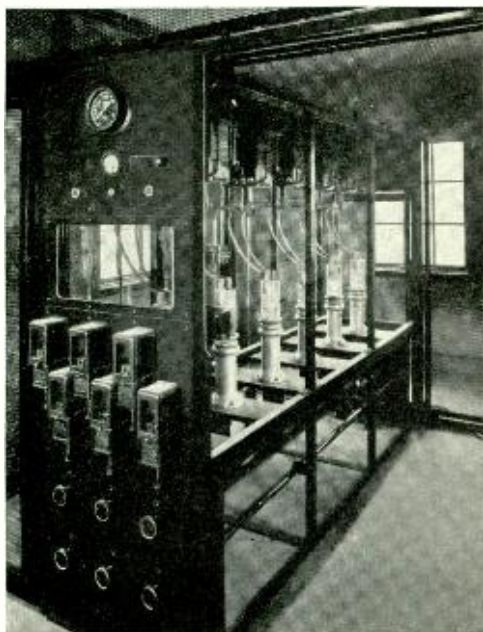

*Fig. 3—One of the two six-phase high-voltage rectifiers for supplying direct current to the transmitters, located in a raised room leading off the center of the transmitting room*

proper sequence. The final step is the application of high voltage to the plates of the power-amplifier tubes, which is possible only when conditions are such that it will cause no damage. The fulfillment of these conditions is insured through the agency of an

alarm and protective circuit, which is also effective in turning off the high voltage should trouble develop while the transmitter is in operation. It consists of a group of relays with associated signal lamps and may justly be termed the guardian of the transmitter. Most of these relays are located on the second panel from the left and are clearly visible in Figure 5. The signal lamps, of which there are forty-eight, are located within the rectangular area at the top of the panel. Thirty-six of these lamps serve to indicate circuit conditions prior to applying high voltage to the transmitter and causes of interruptions thereafter. These indications are specific to the more probable difficulties, and group the remaining in such a manner that their causes may readily be determined.

A guardian is not always infallible; sometimes it becomes necessary to guard the guardian. To this end the power supply for the alarm and protective circuit has been subdivided into twelve independently fused circuits. Twelve signal lamps connected to the load side of the fuses indicate fuse and power-supply conditions on these circuits. The lamps have a two-fold purpose: they indicate whether the alarm and protective circuit is telling the truth; and if it is not, they reduce to one-twelfth the places where this circuit is to be investigated for trouble.

When trouble develops in the transmitter itself, the protective circuit disconnects the high-voltage plate supply to the power amplifiers. Some of the conditions which cause this circuit to function are: overloads in amplifier and rectifier anode circuits; excessive water temperature; and failure of grid-biasing potential, filament-heat-

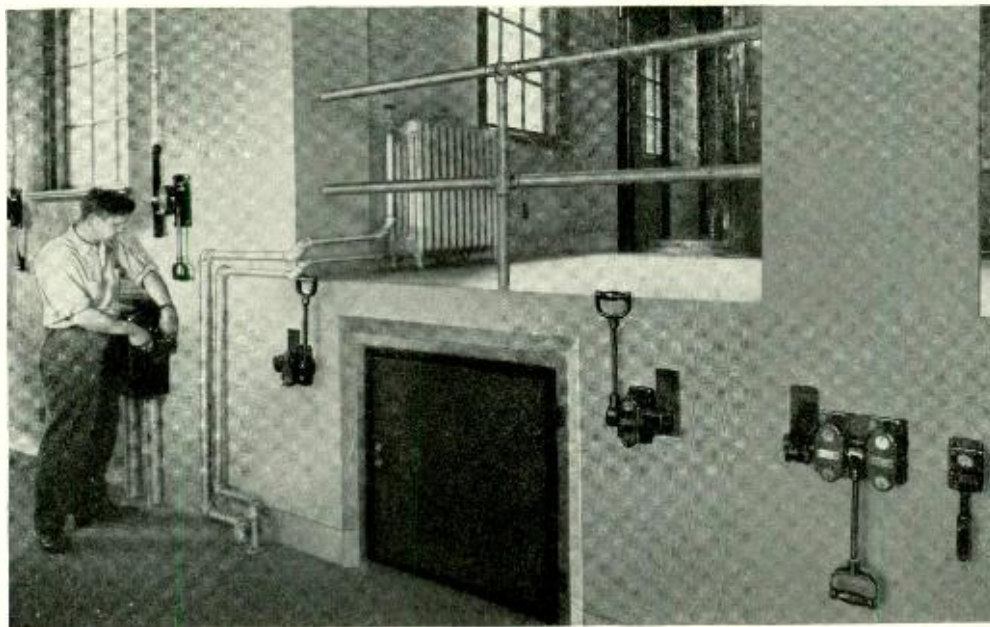

*Fig. 4—Switch-handles of the interlocking system, in the transmitting room*

ing supply or water flow. Each time an interruption occurs, one or more lamps go out and an audible signal operates for ten seconds to attract the station-operator's attention. By consulting the signal-lamp panel, causes for interruptions, and in most cases the particular thing responsible, may readily be ascertained and the transmitter returned to service with a minimum loss of time. An effective system should always indicate danger when something happens, regardless of whether it is a bonafide failure in equipment or a defect in the signal itself. In the system used at Lawrenceville, signal lamps operate on the principle of "light on" when conditions are correct and "light off" when trouble occurs. Had the reverse scheme been selected, a burned-out lamp might cause endless delay. A dark lamp in the present system, when the circuit is operating normally, convicts itself.

The power-control board has also

been equipped with a master control system, to facilitate operations during routine handling of the set in commercial service. By throwing one switch the master control may be cut into or out of service. If it is in service, all equipment is automatically started and power applied to the transmitter by momentarily depressing the master "start" button. This completes all necessary operations up to the final step of applying the high voltage to the power amplifiers. The transmitter may be shut down by depressing the master "stop" button.

Each channel is provided with its own water-circulating system for cooling the anodes of the rectifier and power-amplifier tubes. It is, while operating, a closed circulating system, consisting of two water pumps, a water meter, three water-cooling units (Figure 6), a storage tank, and the necessary valves and the like. A closed circulating system is one in which the column of water is unbroken from

the discharge side of the pump to the suction side. At Lawrenceville this is the condition which exists when the pump is operating; but, as soon as the pump stops, all water drains from the cooling units, and the pipes to and from them, into the storage tank in the power room.

In designing a water-cooling system for vacuum tubes it is important to prevent aeration of water and to eliminate air circulating in the water columns around tube anodes. Precaution against trouble from the latter was taken by the installation of air valves at strategic points in the feed and discharge lines. For the proper operation of the cooling units

it is necessary to locate them in a room open to the outside atmosphere and for this reason draining is essential to prevent freezing of the water in winter during idle periods. Although the discharge side of the system drains when the pump stops, water is retained in the tube jackets at all times by check valves in the feed line. Only one of the two pumps is used to circulate water. Either can be cut into service, and a change from one to the other can be effected, from the power control board. It is unnecessary to operate valves, and the attendant, therefore, is not required to leave the transmitter room in order to make a change.

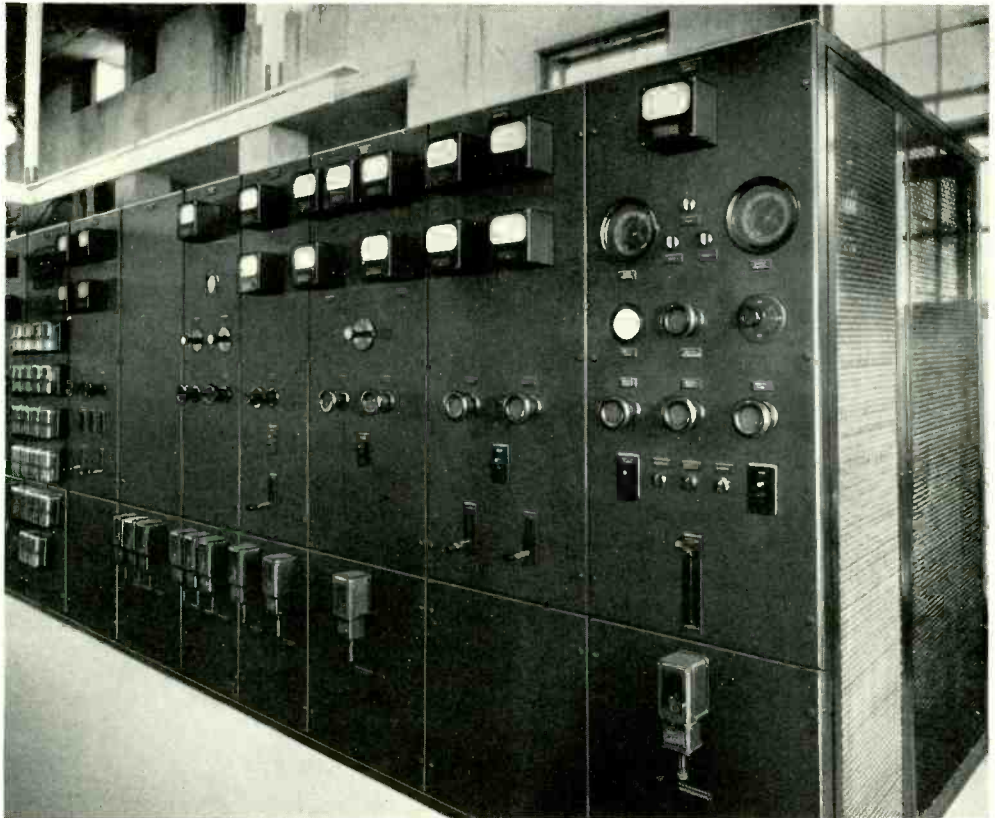

*Fig. 5—One of the two power-control boards, in the transmitting room, for remotely controlling the power supply to the transmitters*



*Fig. 6—The three water-cooling units associated with water-cooled vacuum tubes in transmitters and rectifiers*

At present one and eventually two three-phase power-transmission lines, following different routes from the Lawrenceville substation of the Public Service Electric and Gas Company, will supply power to the radio station. At the property edge the overhead line terminates and underground cable-runs continue to outdoor substations. Each building has its own substation, where the voltage is stepped down from 4000 to 2300 volts, and whence four 2300-volt cables supply all power for the building.

Two of these cables, each of which supplies one transmitter, terminate in the power-transformer vaults of their respective transmitters. A bank of step-down transformers in each vault supplies all auxiliary power requirements for one transmitter at 220 volts. The main load, the rectifier transformer, connects directly to the 2300-volt supply and steps up the voltage to 12,600 maximum. A tie cable between the two power-trans-

former vaults permits the operation of two transmitters on a single cable in case of a failure on one cable.

The other two 2300-volt cables, one of which is a spare, provide for the building's light and power requirements. They terminate in a vault in another section of the building which is altogether independent of the transmitter layouts.

For the safety of personnel and the protection of equipment in the

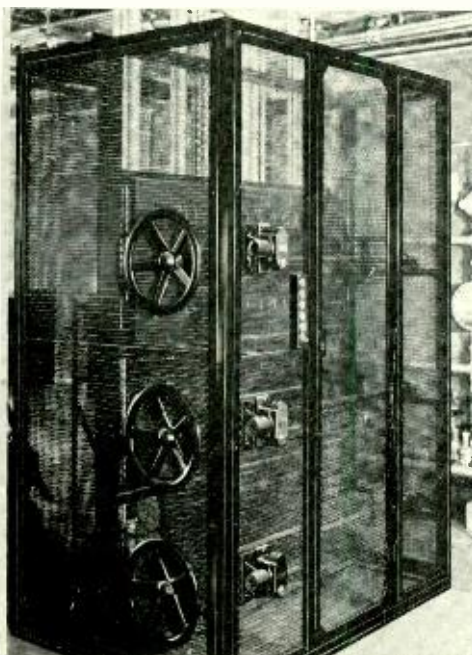

*Fig. 7—One of the two transfer switch units, in the power room, for substituting motor-generator sets*

plant an interlocking system has been adopted which is similar to that employed in modern central power stations but modified to meet the special requirements of the radio installation. It is a mechanical, key-operated scheme, in which the locking units are attached directly to switch-operating handles or vault-enclosure doors. Its protective feature lies in the fact that

a particular key is required to perform a certain operation. The completion of the operation locks the key in the unit and releases another key which permits executing a subsequent operation. In some cases where several conditions must be satisfied before it is safe to replace a key, a unit known as a transfer-key interlock is used, in which several keys are required, each in its proper place, to free a single key.

Some operations which the interlocking system prevents are: opening disconnect switches under load; gaining admittance to "live" enclosures; throwing switches in the wrong sequence; and tying two transmitters to a single spare piece of equipment. The layout is arranged for operating convenience, and in such a manner that its use will not occasion undue loss of time. To this end, for example, the disconnect-switches in the transformer vaults are remotely controlled by operating handles located in the transmitter room (Figure 4).

A near view of one of the transfer-switch units appears in Figure 7. Here the interlock units controlling the movement of the switches, a key box, and an enclosure-gate lock, are clearly visible. The key permitting entrance to this unit occupies the lower position of the key box. It is shown in place and not available until five conditions have been satisfied, and five keys obtained and inserted in their proper places in this unit. Upon removing the lower key the other five are locked in place and not obtainable until the removed key has been returned. The key operating any en-

closure gate is not recoverable until the gate has been closed and locked.

This safety interlocking scheme is not confined to equipment within the building. It is a progressive system extending from the main 4000-volt power supply disconnect-switches, through the substations and buildings, to and including the antenna disconnect-switches.

The transmitters proper are not equipped with interlocking units such as have been described. Protection is obtained by an electrical system employing electric door-locks and door-switches, entirely automatic in its operation. Except by force or other unusual methods, access to any compartment is not possible until the high-voltage supply line to the transmitter has been grounded. In performing this operation, all sources of power supply to the transmitter, except that for heating filaments, are disconnected, and then all door-locks are energized. Upon opening any door, the grounding switch is locked in the grounded position and is not released until all transmitter doors have been closed again.

Adequate provision has been made for the expansion of this multi-channel transatlantic project. The present property will accommodate several more two-channel buildings of the present type, and their necessary antenna structures. Should future development make possible the use of longer transmission lines or smaller antennas, the layout of the building itself is such that additional transmitters may be installed by building to either side of the present structure.





# The Transatlantic Short-Wave Transmitters

By E. B. FERRELL  
*Research Department*

---

THE scheme of transmission used in transatlantic short-wave telephony, and the method by which this scheme is carried out, are fundamentally neither novel nor unfamiliar. Carrier power is obtained by amplifying the output from a crystal oscillator and multiplying its frequency, in two steps. The carrier is then modulated by the voice currents, and the resulting radio-frequency signals are amplified in two stages, and finally brought to the antenna where the carrier and both side bands are radiated. But with these fundamentals familiarity ends. The high powers and high frequencies employed have made necessary the design of new equipment and the solution of novel difficulties; a simple example well illustrates the nature of some of these problems.

Everyone believes that Ohm's law holds as well at twenty million cycles per second as it does at twenty cycles per second, but of the validity of this belief it is rather difficult to give any practical demonstration. An ordinary ammeter of the thermocouple type is no longer accurate at these frequencies. But worse than that inaccuracy is the difficulty of placing the meter in the circuit. If it is desired to measure the current in a tuned circuit, the conductor is cut, the meter is inserted and the reading is noted. Probably an appreciable part of the current in question is flowing through some stray

capacity and not through the meter. This probability not only casts doubt on the accuracy of the measurement, but raises the question of what current really should have been measured. Almost certainly the insertion of the meter has changed the stray capacities, and the circuit must be re-tuned. The circuit may not even function as it did before.

Such stray, or distributed, capacities and inductances furnish the problems which, probably more than any other, distinguish the design of short-wave from that of other radio apparatus. This problem becomes more difficult with increase of either power or frequency. Increase in power requires higher voltages and currents, and thus larger apparatus spaced farther apart. The augmented bulk increases both the stray capacities and the unwanted inductance of leads, and higher frequency makes worse their bad effects. From this standpoint, higher frequency and higher power are mutually antagonistic.

The short-wave transmitter now used at Lawrenceville, N. J., on the transatlantic telephone circuit has a power limit of fifteen kilowatts. With the present method of modulation, which is the same as that used by broadcasting stations, this corresponds to sixty kilowatts on the peaks, with one-hundred per cent modulation. That is, a fifteen-kilowatt telephone set of this type could, with proper

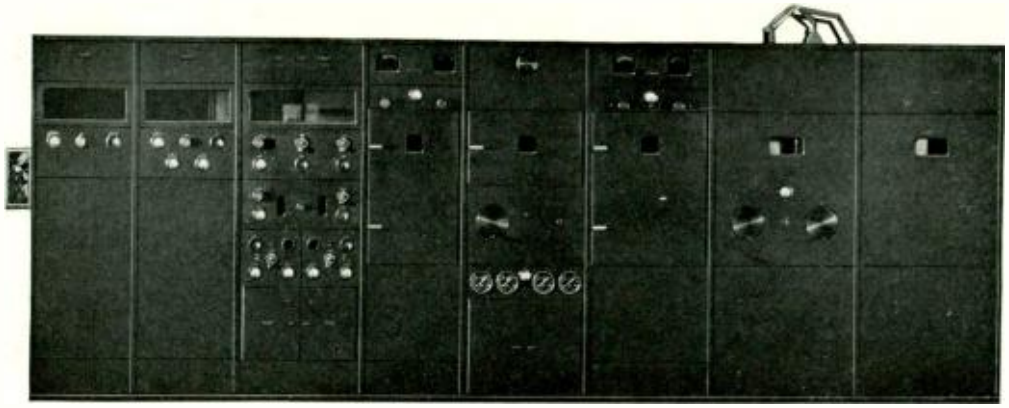

*Fig. 1—Broadside view of the Lawrenceville transmitter. Left to right: two units for speech-amplification, a unit for radio-frequency generation and modulation, a unit for each of the first stage of radio-amplification, the interstage circuit, and the last stage of amplification, and a double-sized unit for the output circuit. The overall length of the set is as much as three-eighths of a wavelength*

power supply, be pushed to sixty kilowatts as a telegraph set.

The idea has been kept in mind that other systems, such as single side-band with suppressed carrier, might be used. For this reason the amplifiers, which could be used with any probable system of modulation, have been extensively developed instead of high-powered oscillators or harmonic generators. The amplifiers have also been made "linear,"\* and have been built as a more or less distinct unit, so that they could be used with other types of input equipment employing new systems of modulation. Electrically "last," the amplifiers and their problems will be described first and most extensively.

Across the plates of the amplifier tubes there exist capacities, which are composed of the capacities within the tube, the direct capacity between the tube mountings, and the like. The value of this composite capacity in the

\* The term "linear" is used here not to indicate that the tubes are operated on a linear portion of a dynamic characteristic, but that the output of the amplifier is proportional to the input.

first stage is about fifty micromicrofarads. In the last stage, where six tubes are used, it is about one hundred micromicrofarads. This value cannot be appreciably reduced by any change in design which now seems desirable. The reactance of one hundred micromicrofarads at twenty megacycles is about eighty ohms. Thus the designer is faced at the outset with a generator—the tubes—which has an internal impedance of a few thousand ohms, but across whose terminals is strapped an eighty-ohm reactance. This condition is an important limitation in the design of succeeding circuits.

Each short-wave channel operated by the Bell System for transoceanic telephony uses at least three frequencies, covering a range of at least two to one. To cover this range with a single variable condenser would be almost impossible. The initial capacity of the circuit is very high, and placing a variable condenser in parallel with it would only aggravate the condition of low reactance between plates. Moreover, at the voltages

used, a condenser of any considerable capacity occupies many cubic inches. Instead of changing the operating frequency by a variable condenser, therefore, the coils of each circuit to be tuned to the final operating frequency must be changed for each such major change in frequency.

In the first stage of amplification, the variable element which makes exact tuning possible is a series condenser, inserted in the middle of the inductance. This lowers the net capacity in the circuit, thus permitting the use of larger and more easily constructed coils, and provides a means of coupling to the load of that stage. In the last stage, this series capacity becomes solely a coupling capacity, and the actual tuning is done by means of a short-circuited turn. Because of space and insulation difficulties a turn whose plane could be rotated was not used. Instead, its coupling to the main coils is varied by sliding it up or down, into or out of the field.

Problems of strays arise with inductances as well as with capacities. It is important that various parts of the transmitter be shielded from each other to prevent stray capacities from forming low-impedance feed-back couplings. To this end each stage of amplification, and at high power each tuned circuit, is in a separate shielded compartment. The elements themselves are rather large, and to keep down stray capacities, as well as to prevent actual voltage breakdown, they are spaced well away from the shields. This makes the compartments from twenty-four to thirty inches across. In an early design, the lead joining the interstage tuning condenser to the grid of the last stage was a little over two feet long. With the return circuit, this formed a loop

of one or two microhenries inductance, causing serious resonance troubles within the operating range of frequencies. Since this inductance could not be reduced, it was increased a little to form a new mesh in the circuit. The interstage circuit is now a double-mesh circuit, with the variable tuning condenser as the common element.

Singing, the common name for spurious or parasitic oscillations, which caused a considerable amount of trouble in early development, is avoided at the operating frequency by neutralization. At higher frequencies this simple remedy is inefficient, and a very stubborn singing in the neighborhood of seven meters occurs. This has been eliminated principally by introducing resistance components into some of the stray capacities which are coupled to the circuit.

In addition to these two types of singing, there are five other well defined types. They have occurred for the most part in circuits involving choke coils and have been eliminated by the introduction of resistance in such a way as to have a damping effect at the singing but not at the operating frequency.

Although these problems of the amplifiers are aggravated due to the combination of high frequency and high power there, problems of as great difficulty beset the design of the low-powered equipment. An interesting example is that of providing crystal control for the high-frequency carrier.

Since crystals cannot be operated if they are as thin as would be required to give the frequencies used here, thicker crystals of lower frequency are used in conjunction with harmonic generators. The crystal is

of suitable thickness to give three and a third megacycles. The crystal oscillator drives a tube whose plate circuit is tuned to the third harmonic, ten megacycles. The action may be compared to that of driving a pendulum by giving it a sharp blow on every third swing. To gain much amplitude these blows must actually push the pendulum for very short intervals

and must be very carefully timed. Electrically, the harmonic generator tube is operated with high grid bias so that current may flow in its plate for only a short part of each cycle of the driving frequency. The plate circuit is tuned in such a way that these short pulses of current flow only for a short part of every third cycle of the output frequency.

This harmonic generator drives another which doubles the frequency, thus giving a final frequency of twenty megacycles. The plate circuit of this last harmonic generator is also the tuned circuit of a simple push-pull oscillator. Thus, although the oscillator supplies most of the power to this circuit, its frequency is controlled by the harmonic generator and indirectly by the crystal oscillator. The accuracy and stability of the final frequency is then the same as that of the crystal oscillator.

This controlled oscillator is modulated by means of a two-stage speech amplifier. The first stage has a six-hundred-ohm input impedance and uses a fifty-watt tube. The second stage uses four 250-watt tubes in parallel.

The need for simplicity and symmetry

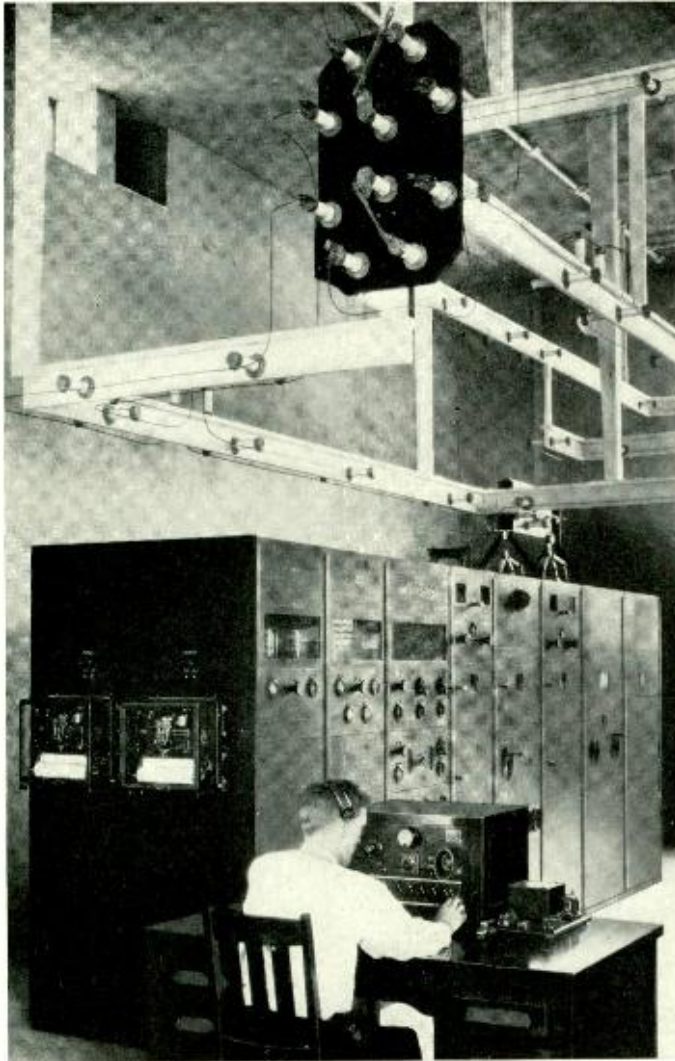

*Fig. 2.—The transmitter of Figure 1 in the transmitting room of Building A at Lawrenceville*

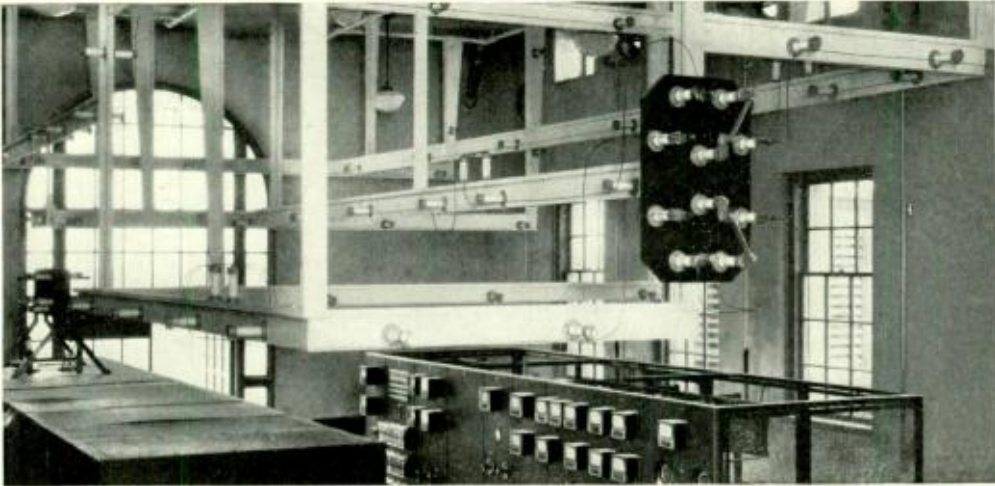

*Fig. 3—A corner of the transmitter room*

in the radio-frequency circuits has prevented the insertion of ammeters at convenient points, to study the characteristics of the transmitter. For the desired radio-frequency indications, therefore, monitoring rectifiers are used: five-watt tubes, used as two-element rectifiers, with 100,000 ohms resistance in their plate circuits. The high resistance, together with the stray capacities, constitutes a peak voltmeter which has linear characteristics. These radio-frequency voltmeters are used in pairs. The sum of the rectified currents of a pair is most often the reading of interest, but the difference of the two can be used to measure the unbalance of the circuits. A pair is coupled, through small capacities, to the grids of the first stage of high-power amplification, another to the grids of the last stage, and a third to the plates of the last stage.

The monitoring rectifier on the plates of the last stage of amplification is also used to judge the quality of the speech. Since it has linear characteristics, it serves for distortion measurements at audio frequencies.

For example, if a pure eight-hundred-cycle tone is impressed on the transmitter, it, together with any of its harmonics which are produced by distortion in the transmitter, will be heard in the output of the monitor. Its amplitude can be measured by a standard audio-frequency measuring set. The ratio of that amplitude, expressed as peak current, to the direct current output of the monitor gives the per cent modulation. The harmonics may be separated by filters and measured, to indicate the amount of distortion. It is found that, when the transmitter is in proper adjustment and the audio-frequency tone is such as to give one-hundred per cent modulation, the distortion products are all as much as twenty-five decibels below the fundamental.

The frequency, twenty megacycles, corresponding to a wavelength of fifteen meters, is mentioned several times in this article, merely as a typical frequency. The sets installed at Lawrenceville will operate within the range of fourteen to forty-five meters with fifteen-kilowatt carrier output.

# Short-Wave Transmitting Antennas

By E. J. STERBA  
*Research Department*

THE antenna system is the first object to attract the attention of a visitor to the plant at Lawrenceville, N. J., for the tower line west of Princeton is visible several miles from the station. Upon arriving at the station grounds, the antenna system appears to be a complicated network of wires on rugged towers extending more than a thousand feet past the observer. Appreciating that this extended construction is associated with directive transmission, he may feel that the structure is far too complicated for ready explanation. Yet the fundamentals of direc-

broadcast antenna is constructed so as to radiate in all directions with equal intensity, because broadcast reception is generally desired in all directions about the station. For this purpose a single vertical wire or several closely spaced vertical wires may be employed. If a vertical-wire antenna is erected upon an ideal transmitting site, the electric intensity in any direction about the antenna and for a constant distance from the antenna may be represented by the radii of a circle (Figure 1-A), signifying equally good reception in all directions about the antenna. The area of the circle is approximately proportional to the power radiated.

If, however, radio transmission is required only between two points, the radiation of energy in all directions other than that in which the receiving station lies is wasted effort. Suppose, for example, that the receiving station is located at N60°E with respect to the transmitter. If some modification is made in the antenna so that radiation occurs only between the radii five degrees to either side of the direction to the receiving station, and if the power of the radio transmitter is readjusted so that the signal-strength from the simple antenna and from the modified antenna are equal at the receiving station, the area of the shaded ten-degree sector in Figure 1-B is proportional to the power radiated— $10/360$  of that required

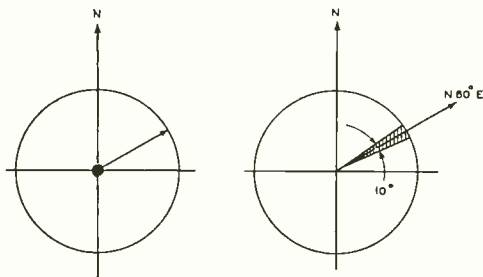

Fig. 1-A (left)—Electric intensity about a broadcast transmitter. The area of the circle is proportional to the power radiated; Fig. 1-B (right)—Shaded area represents energy radiated if transmission is confined to a ten-degree sector

tive transmission and thus of the antenna are quite simple.

A background of broadcast experience has familiarized nearly everyone with a transmitting antenna. The

for the simple antenna. If this ideal case could be set up, the radio transmitter connected to the modified antenna would consume one thirty-sixth of the power formerly consumed. In telephone nomenclature, an equivalent signal strength would be secured from a source 15.6 decibels lower in power level. It is thus of some economic importance to determine how an antenna may best be modified so that radiation is confined to a narrow sector within which lies the chosen direction.

Heinrich Hertz, who in 1887 and 1888 discovered means for producing and detecting radio waves, constructed the first directive antenna. Employing wavelengths of less than one meter, Hertz experimentally concentrated radio waves in a chosen direction by means of a short antenna lying in the focus of a metallic parabolic surface (Figure 2). In principle the scheme was very much like that of an automobile headlight. Hertz also observed that radio waves of the same length from different sources produced interference patterns—recurring positions of intense and feeble signal-strength—near the sources.

Parabolic reflectors similar to Hertz's experimental antenna have been employed for a number of years in short-wave radio transmission. It is essential that the dimensions of the parabolic reflecting surface be several wavelengths, and hence it is impracticable that the surface be a conducting sheet except for use at very short wavelengths. This difficulty was overcome by using a number of wires, spaced so as to outline the surface, and set at critical lengths so as to be resonant at the operating wavelengths.

Interference, well known with light waves and observed by Hertz with radio waves, is an alternative method

for producing directive transmission.\* If two or more narrow parallel slit-sources of monochromatic light are directed upon the same surface an interference pattern is produced, visible as a family of light and dark strips. It is brought about by the difference in phase of the radiation from the two

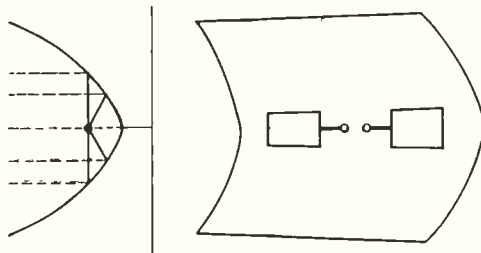

Fig. 2—Parabolic reflector employed by Hertz. The antenna is at the focus of the metallic parabolic surface

sources due to the difference in length of path between the two sources and the screen.

Directive radio transmission by means of wave interference may readily be obtained by transmitting simultaneously from the same transmitter with two or more suitably spaced antennas. If two antennas, one wavelength apart and each carrying unit current, are driven in phase, the electric intensities from both antennas, several wavelengths away in the direction normal to the two, are in phase because the paths from the antennas to the receiving point are equal. The field in this direction is the sum of the fields from the individual antennas. If, however, a direction thirty degrees from the normal is considered, the path from one antenna is one-half wavelength longer than from the other, and the time it consumes

\* The "reflectors" discussed in the preceding paragraph depend ultimately, of course, on interference also.

in traveling this additional distance puts the radiation from one antenna one-half period behind the other. The intensities in this direction are exactly out of phase and thus the net intensity is zero. By simple trigonometry

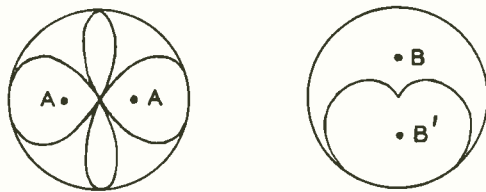

Fig. 3—Directive intensity characteristics for: (A) two antennas spaced one wavelength apart and driven in phase; (B) two antennas spaced one-quarter wavelength apart and driven ninety degrees out of phase (B leads B')

the polar diagram of Figure 3-A may be obtained, representing the intensity in all horizontal directions about the antenna. The radii of the circle enclosing the four-leaf figure represents the intensities which would be realized if the two antennas were very close together.

Forming an example of another simple directive system are two antennas spaced one-quarter wavelength apart and driven ninety degrees out of phase with each other. Since a quarter period is consumed in traveling the distance between antennas, the radiations from the antenna which bears the current lagging ninety degrees will lag an additional ninety degrees upon arriving at the adjacent antenna, and the fields from the two antennas will cancel in this direction. In the opposite direction the fields both lag the same amount and are additive. The polar diagram for this case is given in Figure 3-B, in which again the circle enclosing the figure represents the radiations which would

proceed from the two antennas if these were coincident and in phase. It has been found by experiment that two antennas will form this second system if one is driven by the transmitters and the other is parasitically excited. The parasitic antenna is usually called the "reflector antenna."

The above two schemes may be combined in several possible ways to give unidirectional systems. In general the polar diagram of the combined system may be obtained by superimposing the two diagrams and multiplying by each other the lengths of the coincident radii to obtain the lengths of the new radii.

Simple directive systems, such as

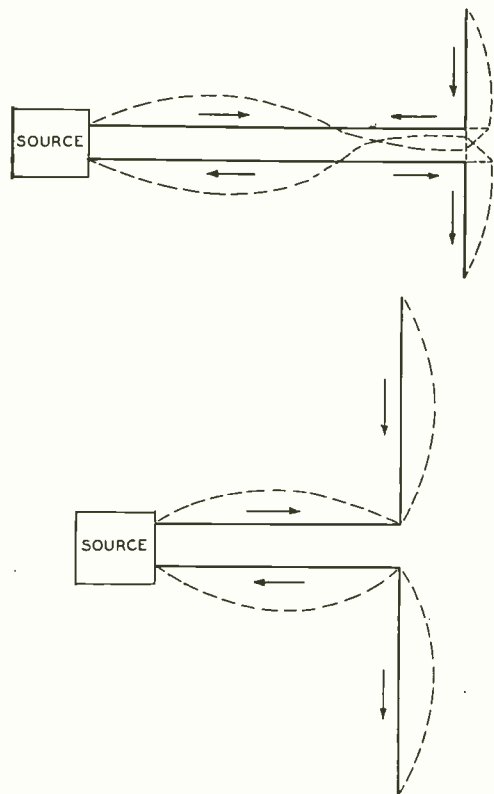

Fig. 4-A (above)—Line bent into a Hertz antenna; Fig. 4-B (below)—Line bent into two Hertz antennas



those described, were proposed by S. G. Brown in 1899 and J. S. Stone in 1901, and many others have since devised increasingly complex and more efficient schemes. Later G. A. Campbell, of the American Telephone and Telegraph Company, proposed a directive scheme comprising several rows, each bearing several antennas in suitable phase relations. He established in a general manner the relations between the spacings and phasings and devised methods whereby the performance of the system, however complex, could be predicted.

In the polar diagrams, the area of the figure, as compared to the area of the enclosing circle, is approximately proportional to the relative power consumption of the directive and the non-directive systems and thus an approximation of the gain of the directive system may be obtained by expressing the ratio of the areas in transmission units. The reason for this gain may be suggested by another simple example. If two antennas, several wavelengths apart, each have a resistance  $R$  and carry a current  $I$ , the total power consumed is  $R I^2 + R I^2 = 2 R I^2$ . The intensity at a point where the radiations are in phase is proportional to  $2 I$ . This same intensity could be obtained by exciting one antenna alone with  $2 I$  units of current but the power consumption would then be  $4 R I^2$ , or twice as much as before. In general the improvement factor of a directive antenna is nearly proportional to the number of antennas, when they are separated by more than about one-half wavelength. This is only approximately true because two antennas, when close together, react upon each other.

There are many methods for the

mechanical construction of directive antennas; that now being employed at Lawrenceville depends upon the manner in which waves stand upon transmission lines. It is generally known that the current in an open-circuited line recurs along it in standing maxima

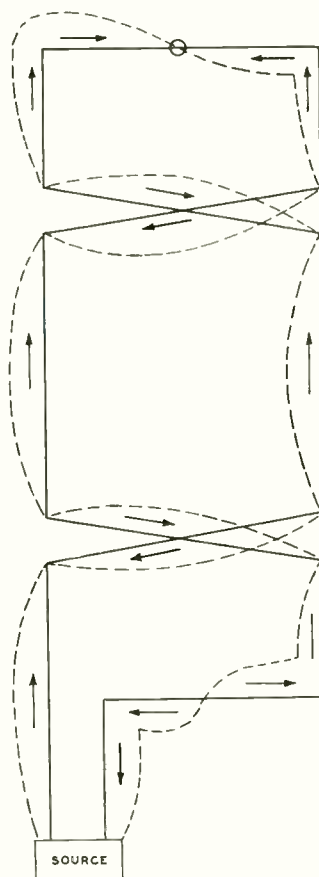

Fig. 5—A panel for the Lawrenceville antenna system. The vertical members are radiators; the crossed members are transmission-line phase shifters. The line may be open or closed at the center of the top cross-piece, since there is a standing-wave node, and thus no current flow, at that point

and minima, that the phase difference between successive current maxima is 180 degrees and that the phase difference between corresponding points



*A part of the line of towers supporting the antennas*

on the two wires is 180 degrees. The radiation from an open-circuited line is small, but if the ends of the line are bent outward, the radiation from these ends will be greatly augmented and the balance of the line will act largely as a means for transmitting power to the radiating end. If the bent portions are each one-quarter wavelength long, a one-half wave Hertz antenna is formed (Figure 4-A). An even more efficient antenna may be formed by bending over a one-half-wave portion of the line; in this case the bent-over portion is equivalent to two Hertz antennas driven in phase (Figure 4-B).

Thence it is only a small step to the panel arrangement of the Lawrenceville antenna system (Figure 5). Here the vertical wires are the radiating members, all excited in phase, and the horizontal pairs are transmission lines

for distributing the current to the radiating elements in the desired phase-relations. The panel is equivalent to four Hertz antennas, two of which are stacked one above the other and of which the two groups thus formed are spaced one-half wavelength apart. Complete reinforcement of signal intensities takes place only in the horizontal direction normal to the panel. In all other directions destructive interference occurs; complete cancellation occurs in the plane of the panel.

By computation and by experiment it has been shown that a power improvement of four decibels is acquired from the horizontal spacing of one-half wavelength, and of two decibels from the vertical stack of two. The net power saving is approximately six decibels: the panel consumes but one-fourth the power which would be re-

quired by one element to produce the same intensity in the chosen direction.

A second similar panel, excited parasitically, is placed one-quarter wavelength behind the first to act as a reflector and thereby create an unidirectional system. It has been found that the reflector reduces the power required to maintain a given intensity in the desired direction by approximately three decibels, and thus brings the gain of the two-panel system up to nine decibels. The two-panel system, therefore, requires but one-eighth the power which would be necessary in a simple antenna producing the same intensity in the desired direction.

Larger power savings may be effected by employing many antennas properly connected together. Practically, however, considerations of mechanical construction, investment and maintenance limit the size of the system. The complex nature of short-

wave transmission also leads to a lowering of the optimum size of the antenna. For wavelengths of the order of sixteen meters, improvements of twenty decibels (a power ratio of one hundred) are practicable.

The connection of a number of antenna panels to a common feeder line must accomplish proper phase and impedance relationships. The former may readily be obtained through adjusting the lengths of interpanel lines, by tape-line measurements. The conventional methods for building up the load impedance to the surge impedance of the feeder line, however, are far from satisfactory for high-power work at short wavelengths. In this case one of the less familiar properties of a transmission line is used for transforming impedances.

If a line of surge impedance  $Z_0$ , exactly one-quarter wavelength long, is terminated with a load  $Z_r$ ; the

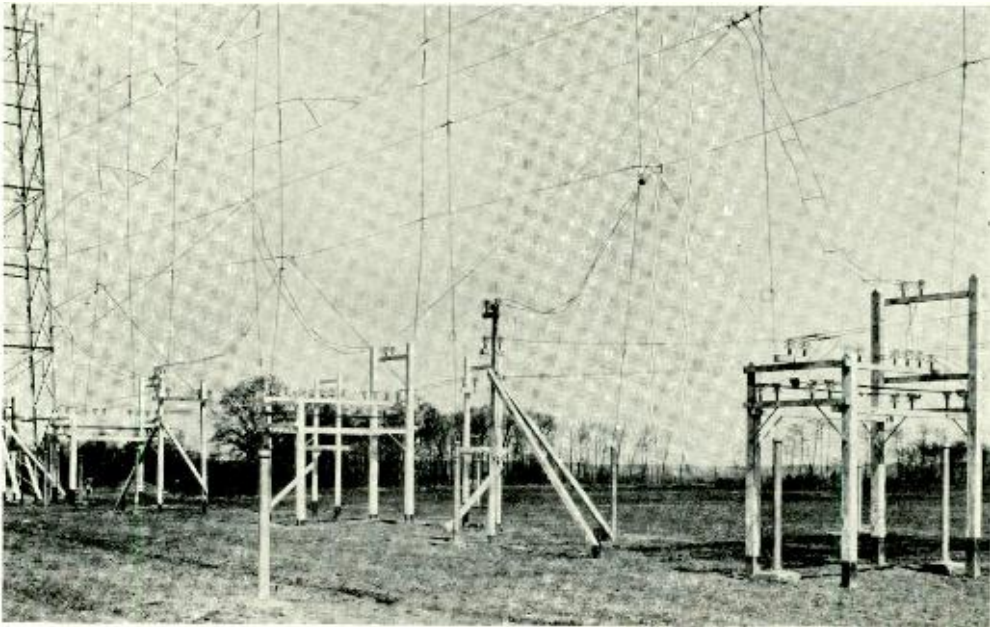

*Lower edge of antenna curtain, and frames supporting the quarter-wave lines for effecting sleet-melting connections and proper terminating impedances*

sending-end impedance of the line is  $Z_o^2/Z_n$  and, if  $Z_n$  is a pure resistance, the sending-end impedance is a pure resistance. Such a quarter-wave line is employed in the Lawrenceville antenna system. Since a line bearing standing waves is being terminated at one upon which standing waves are not desired the receiving-end of the quarter-wave line is connected at either a current maximum or minimum, to ensure a resistance load.

A transmitting antenna is adversely affected both mechanically and electrically by sleet. The sleet load may strain the system to the breaking point and thus put the antenna out of service for a long period, and the mass of ice, having a dielectric constant of eighty, may detune the antenna and destroy the effectiveness of the system. Sleet is, therefore, removed in the Lawrenceville system, by heating

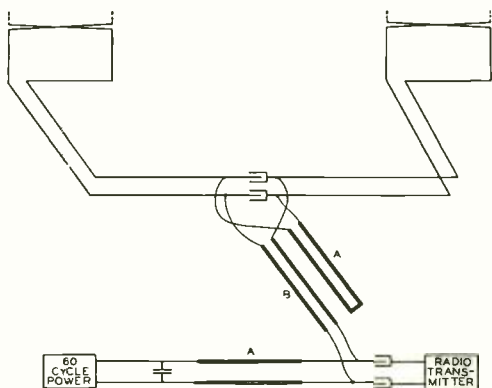
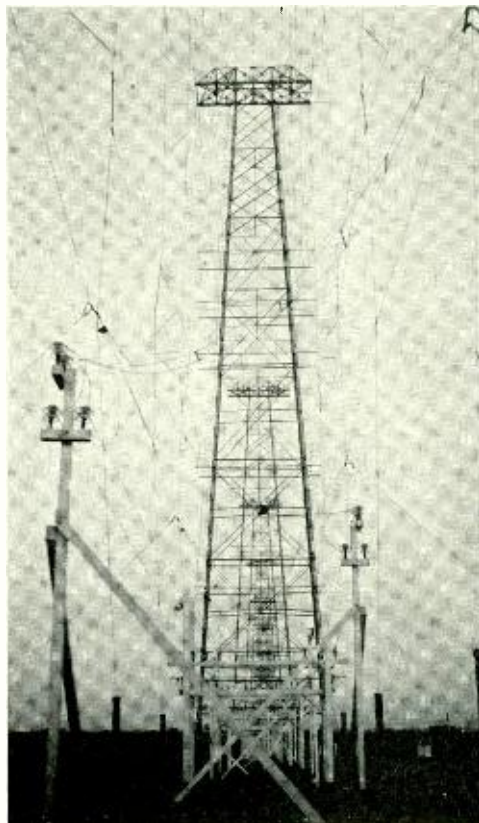

Fig. 6—Antenna connections for melting sleet from the Lawrenceville antenna

the wires with low-frequency currents of about 150 amperes at a potential of nearly a thousand volts in each antenna. All elements in the antenna are arranged to be in series for the low-frequency currents and the vertical elements in phase for the radio-frequency currents (Figure 6).

Another relatively unfamiliar property of transmission lines is utilized to effect this arrangement. If a line one-quarter wavelength long is short-circuited at the receiving end, the sending-end impedance is very large. Such



Looking down a tower line at Lawrenceville. Photo by G. M. Eberhardt of the Research Department

a line may be connected across a circuit of relative low impedance without disturbing its radio-frequency functions. From Figure 6 it may be seen that the anti-resonant circuit of quarter-wavelength bars, in combination with several condensers which readily pass radio frequencies but which block low frequencies, and in combination with two antenna panels, forms a series

circuit for the low-frequency currents and the power source. The two panels, however, are in parallel with each other and with the feeder line at radio frequencies. Both the low and the high-frequency powers may be applied simultaneously to the antenna.

For three of the four communication channels at the Lawrenceville radio plant, the antenna system is supported by a row of nineteen towers at right angles to the direction of England; for the fourth, a row of seven towers is placed at right angles to the direction of Buenos Aires. Guys run along the tops of these towers to anchors on the ground at the ends of the rows. The towers, 250 feet apart and 180 feet high, are designed to withstand the load of the largest antenna that can be supported in a bay, when covered with a coating of ice one-half inch in radius and subjected to a gale of ninety miles per hour. Each antenna occupies two tower-bays. The antenna-curtains them-

selves are supported by messenger cables and may be lowered or hoisted by individual winches; the curtains are constructed from No. 6 B&S wire and are held in position by insulated sections of steel harness. The several panels in each curtain are interconnected by transmission lines which lead to frames where proper connections are made and impedances built up to terminate the power leads from the radio transmitters.

The practicability of directive systems is dependent upon the shortness of the transmitted wavelengths. A twenty decibel antenna, operating on five hundred meters, would be approximately ten wavelengths or fifteen thousand feet long and two wavelengths or three thousand feet high. The investment in such a plant would probably never return dividends. Fortunately the wavelengths used in the transoceanic short-wave system are such that directive effects can economically be obtained.



# The Transatlantic Short-Wave Receivers

By F. A. POLKINGHORN  
*Research Department*

THE function of the radio-telephone receiver is to select the desired signal, to amplify it, and then to detect or demodulate the signal so that its voice-frequency components may be sent over a telephone line to a subscriber.

The problem of selecting the desired signal to the exclusion of others is a major design problem. A directive antenna system serves to discriminate to a considerable extent between signals arriving from different directions, but to only a slight extent between the desired signals and others closely adjacent in frequency. The receivers built for the short-wave transoceanic channels are of the double detection or "superheterodyne" type. This type was chosen be-

cause it is well adapted to give a high degree of selectivity desired, and to provide the large amplification required with a minimum of trouble from regeneration or singing.

Each transmitter and receiver of the transatlantic circuits must be capable of operating on any one of three frequencies in the range between 9,000 and 21,000 kilocycles in order that the operators may pick a frequency upon which transmission is good at any particular time. At the receiving station each receiving unit consists of three antennas and a receiving set. The antennas are located several hundred feet apart so that they do not influence one another. At each antenna there is a circuit which aids in obtaining the desired direc-

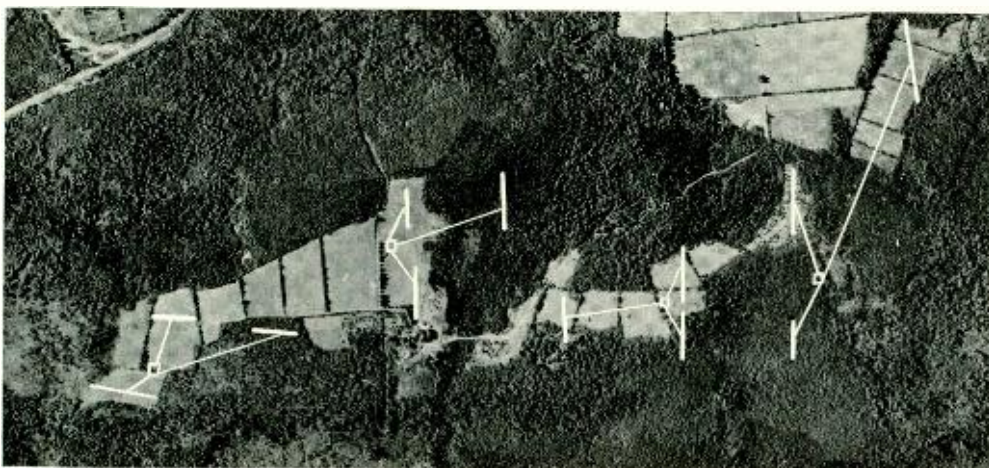
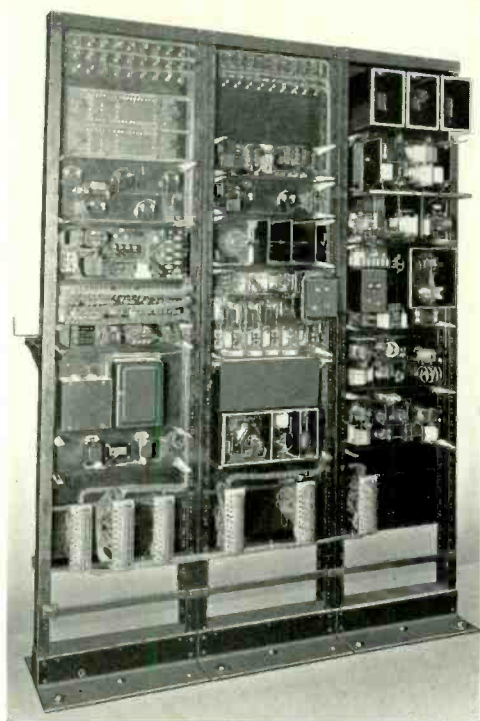

Fig. 1—Airplane view of Netcong, N. J., showing locations of receivers (as white squares), antennas (as heavy white lines), and antenna transmission lines (as light white lines)



*Fig. 2—Rear view of a receiver*

tional characteristics from the antenna and acts as a transformer to connect the antenna to the transmission line leading to the receiver. This transmission line, formed by copper tubes, one within the other and separated by insulating rings, is supported a few inches above the ground. It follows a sinuous course, with bends to allow for expansion and contraction under temperature changes.

The receiver has three antenna circuits which are always connected to their respective antennas and to the grids of three screened-grid vacuum tubes of the 246-A type. A switch in the plate circuits of these tubes determines which of the antenna circuits is to be used at any one time. An additional stage of screened-grid amplification is then used.

The incoming signals next reach the

first demodulator where they are combined with another frequency such as will give a beat, or intermediate, frequency of 400,000 cycles. For example, if it is desired to receive a frequency of 18,310 kilocycles, the beating oscillator of the receiver is adjusted to either 17,910 or 18,710 kilocycles. Either of these frequencies when combined with the received frequency of 18,310 kilocycles gives a beat frequency of 400 kilocycles. This intermediate frequency is then passed through a narrow band-pass filter. Six additional stages of amplification

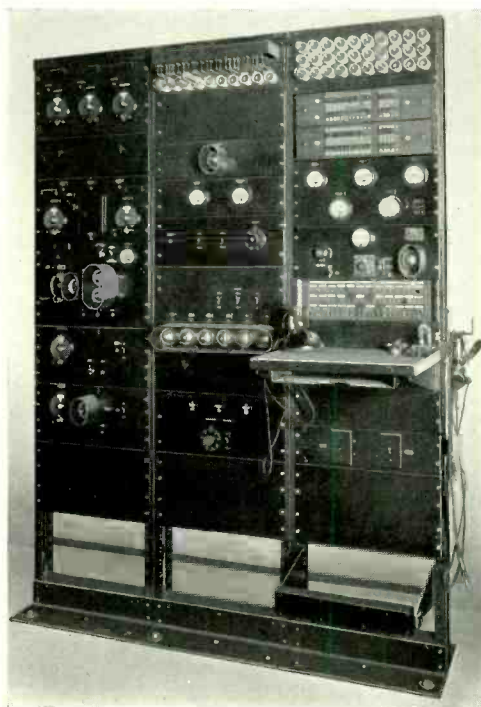

*Fig. 3—Front view of a receiver*

follow the filter. An attenuator is inserted between the first and second stages for control and measuring purposes. Another band-pass filter is used to connect the last amplifier to the second demodulator, where the speech frequencies are reproduced.

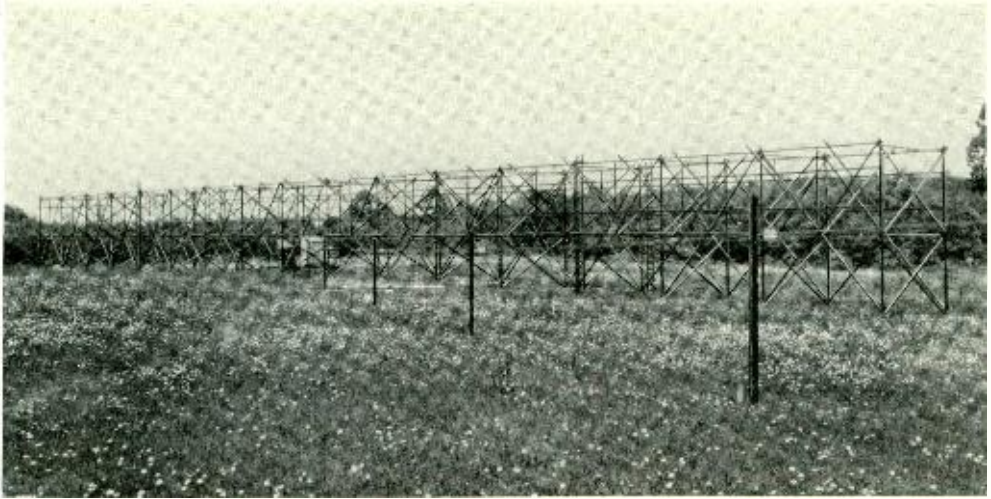

*Fig. 4—General view of a receiving antenna*

One stage of voice-frequency amplification brings the speech-level to that required for transmission over the cable to the central terminal building, where the speech is further amplified and sent over the line to the transatlantic operator in New York.

When received at any single point, waves of the frequencies used on these channels are subject to wide fluctuations of intensity, probably because the waves proceed over several different paths to the point, and there aid or oppose each other in a random manner.\* This fading causes the voice-frequency output of the receiver to vary somewhat periodically at frequencies between once every few seconds and many times a second. Such changes in volume are quite disconcerting to a subscriber and consequently an automatic gain control has been included in the receiver to minimize this trouble.

The automatic control acts to change the gain in the receiver in inverse proportion to the strength of

the received signal, thus causing the output level to remain substantially constant. This is accomplished by using an additional amount of intermediate-frequency amplification in an auxiliary amplifier, rectifying the output of this amplifier and applying the rectified output voltage as additional bias on the grid of the first demodulator. An increase in the received signal tends to increase the output of the rectifier which, when applied to the grid of the first demodulator, decreases its efficiency and greatly reduces the rise in output volume of the receiver over what would otherwise be obtained.

The appearance of these receivers is quite different from the ordinary receiver used for broadcast reception. Since the receivers are an integral part of the telephone plant, standard telephone construction was used as far as was practical. All apparatus is mounted on brass panels which are in turn mounted on relay racks. The panels are faced with mats of furniture steel to hide the numerous screw holes necessary for mounting

\* *H. T. Friis, BELL LABORATORIES RECORD, July, 1928.*



the many small parts in place. Fuse panels provide protection for all plate and filament circuits. In addition each plate circuit is provided with a protective lamp.

Any filament or plate current may be read by inserting a short-circuiting plug into the corresponding jack in a jack strip, and thus connecting one of the meters on the meter panel into the circuit through an auxiliary fuse. This means may be used to keep the set in operation while replacing a fuse. A dummy plug placed in a jack will open its circuit; an external meter may be plugged into a circuit by means of a cord.

Telephone and telegraph facilities for use of the operator are mounted directly on the set. Head receivers and a monitoring coil are provided so that the operator may monitor the circuit when required. A volume indicator is constantly connected across the output of the voice-frequency amplifier. By observing the volume indicator and the meters connected in the second demodulator and rectifier

a good idea of how the set is operating can be obtained at any time. A high-frequency oscillator and an intermediate-frequency oscillator are included in the receiver so that the set may be completely adjusted, and the adjustments be readily checked, without the aid of a received signal.

For all tubes "filament-failure lamps" are provided, which give a red indication when a filament fails. Since there are a large number of tubes of four different types in the set, a name plate is used to designate each tube position and the type of tube to be used in that position.

Shielding, to prevent regeneration in the high-frequency and auxiliary gain-control amplifiers, is provided by the mats, parts of which are hinged on certain panels to form doors opening into compartments behind the panels where the tubes and circuits are placed. Throughout the design of the receiving equipment every effort has been made to ensure convenient and reliable operation in routine commercial use.



# Short-Wave Receiving Antennas

By E. BRUCE  
*Research Department*

IMPROVEMENTS in any point-to-point radio system should be made first at those places where a given overall result is least costly to secure. In particular the effect of increasing the power of a transmitter can equally well be secured by improving the effectiveness of either the transmitting or the receiving antenna. The expense of high-power transmitters is very great, and the designer of receiving antennas can command a considerable working budget without being underbid by the designer of transmitters.

The design of receiving antennas is important for other reasons as well. An apparently irreducible minimum of noise is inherent to the input circuits of the first vacuum tube\* of the radio receiver. To override this noise, increased antenna efficiency, through directivity, becomes the most fruitful means of increasing the signal "pick-up." When static rather than internal noise is the limiting factor, antenna directivity again accomplishes an improvement. Signal waves come from a rather definite direction toward the receiver; static disturbances, on the other hand, come from nearly all directions at random. The directional receiving antenna, responsive only in the direction from the transmitter, takes full advantage of the

desired signals, but discriminates against all static disturbances except those which approach the antenna from the responsive direction.

An antenna will develop directional properties if it is built up of distinct wire-segments or "elements," and if these elements are spaced apart by a suitable and fairly large fraction of the wavelength of the signal which the antenna is expected to pick up. Only with the use of "short waves" did it become economically practicable to build systems large enough compared with the wavelength to take advantage of this directivity. The short-wave transatlantic antenna employs a row of equi-spaced elements, identical in their phases and power levels. This form of antenna is often termed "broadside," as it is maximally active to waves proceeding perpendicularly to the row of elements.

There are numerous ways of so interconnecting spaced elements as to obtain specified phase and power relations; the way most suitable for commercial use is, of course, that which necessitates least adjustment and which accomplishes the desired directivity with the simplest structure. A long wire can be folded back and forth in space in a simple manner to give the desired phase relations for "broadside" directivity. If the attenuation along it is negligible, the elements will all have equal power levels with reference to all points of the antenna.

\* *The cause and effect of the random voltage fluctuations which occur in resistances are discussed by J. B. Johnson in the RECORD for February, 1927.*

Such a structure is shown in Figure 1. The lengths of the vertical elements, and the spaces between them, are one-quarter of the length of the signal wave which the antenna is expected to pick up. Such a wave, traversing the antenna, induces in the vertical elements voltages which are equal but whose phase relations depend on the direction of approach of the wave. In analyzing the behavior of the antenna, these electromotive forces may be represented by lumped voltages at the central points of the verticals.

Each lumped voltage can be supposed to cause in the wire a succession of electrical disturbances whose sense and magnitude depend on the sense and magnitude which the volt-

age has at the successive instants. The disturbances successively originated at a voltage source can be regarded as passing out along the wire in both directions from the voltage source, as two trains of disturbances which retain their senses and magnitudes. The passage of such a train constitutes a current. When two currents passing in the same direction are composed of disturbances which correspond in sense at all points, the two reinforce each other. When, however, the disturbances composing two currents passing in the same direction are of equal magnitudes but opposite senses, the two cancel.

Thus from each source of voltage electrical disturbances will pass both to the receiver and to the open end of the antenna. Those proceeding to the open end will be reflected there and will thence in turn pass, with magnitudes unchanged but with senses reversed, to the receiver. Maximum reception will occur when the signal wave approaches in such a direction that the voltages it induces in the antenna produce disturbances which are additive on reaching the receiver. No reception will occur when these disturbances cancel at the receiver.

When the signal wave is proceeding broadside to the antenna, it induces in the vertical elements voltages which are identical in phase from the

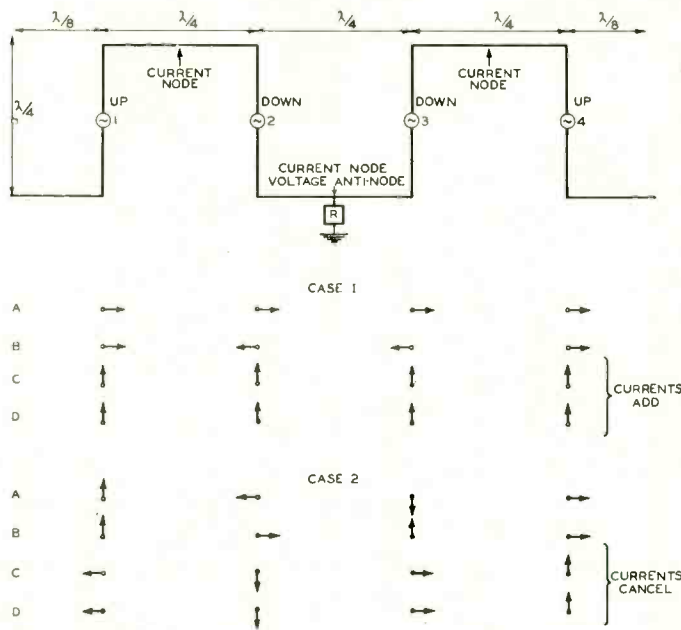

Fig. 1—Behavior of broadside antenna to broadside (Case 1) and end-on (Case 2) waves. The vectors are drawn below the elements whose electrical effects they represent. A—space voltages; B—wire voltages; C—currents in R (directly propagated); D—currents in R (by open-end reflection)

standpoint of the plane of the verticals. Figure 1, Case I, shows in row A voltage vectors drawn below the elements to represent the voltages at a particular instant. The manner of connecting the verticals, however,—alternately at their upper and lower ends—vitaly distinguishes between the voltage phases viewed from the plane standpoint and from the wire standpoint. When the vertical elements and their horizontal connections are regarded as one continuous wire, the folding in space effectively alternates the voltage phases of the successive vertical elements of the wire, for either side of the receiver R. These voltage vectors are shown in row B.

At each source of voltage, similar voltage vectors recur with a frequency equal to that of the incident wave. Since one wavelength is the distance between sources of voltage whose voltage vectors are simultaneously similar, each disturbance propagated in either direction arrives at the next similar voltage source exactly one cycle later. Thus the disturbances propagated in either direction reinforce one another. The currents proceeding toward the receiver do so in phase and produce an additive effect. Their current vectors appear in row C. Those proceeding toward an open end likewise do so in phase, and are there reflected back toward the receiver with their component disturbances reversed in sense. Since the total current reaching the open end travels a quarter-wavelength from the last voltage source to the end and an equal distance back to that source again, a half-cycle elapses between the two visits. But the reflected current of reversed disturbances finds there on its second visit a reversed voltage,

propagating a reinforcing current. The reflected currents, therefore, proceed toward the receiver in phase with, and thus adding to, the directly propagated currents. These current vectors appear in row D. Altogether it is evident that the antenna is in this case making the most of all its currents for the benefit of the receiver.

When, as in Case II of Figure 1, the wave approaches the antenna end-on—at right angles to the broadside wave of Case I—the antenna acts with very different effect upon the receiver. In Case I any one part of a signal wave traversed all elements of the antenna simultaneously; in Case II it traverses them successively. Alternate sources of voltage, which are a half wavelength apart in space, are a full wavelength apart along the wire. Thus any part of a signal wave which has induced a voltage in an element will reach the next-element-but-one through space a half cycle before the disturbance it caused in the first element, proceeding in the same direction, can reach the new element through the wire. The disturbance proceeding in the opposite direction will reach the next-element-but-one a cycle and a half after the part of the wave which produced it has passed that element. This is the time of the signal in advancing a half wavelength through space plus the time of the disturbance in returning a full wavelength through the wire. When either disturbance reaches the next-element-but-one from its source, a later part of the signal wave will be inducing an equal but opposite voltage in that element. The resulting disturbance will be equal and opposite to the arriving one and will cancel it. All currents, therefore, in either direction in the antenna will annul one another, so

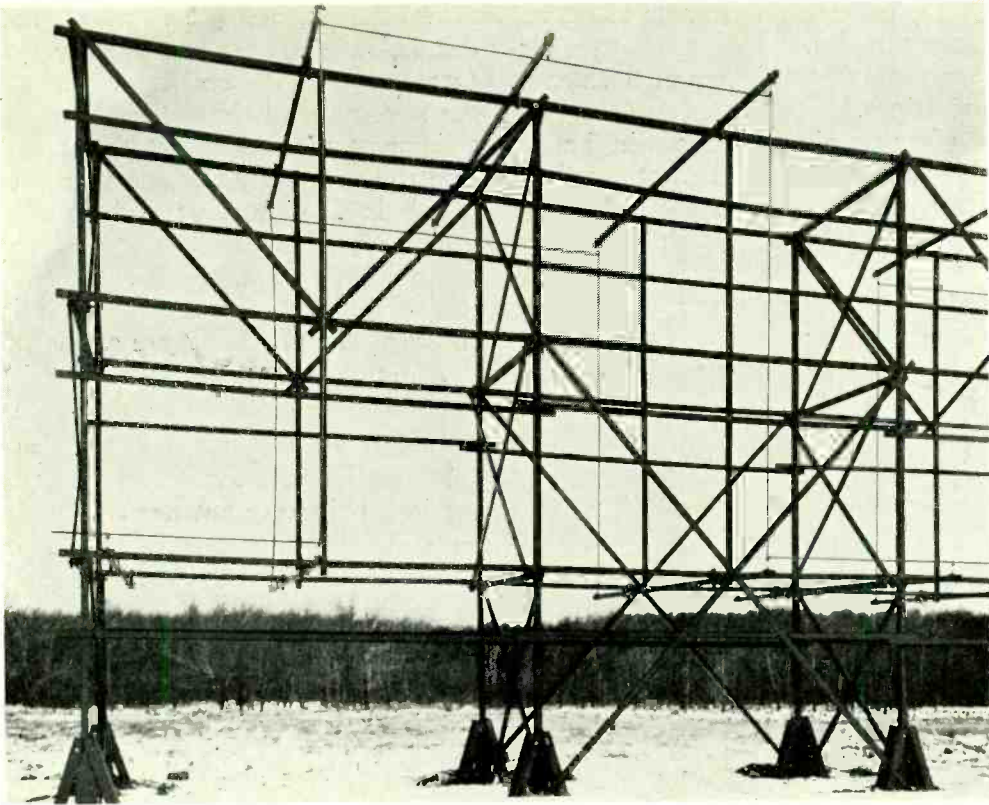

Fig. 2—One end of a short-wave directional receiving antenna at Netcong, N. J.

that the receiver will not be energized.

This antenna, accordingly, has maximum sensitivity to a broadside wave (from either direction) and no sensitivity to an end-on wave. To waves of intermediate direction it has intermediate sensitivity. Relative sensitivity can be plotted against direction in a polar diagram to show the sensitivity-characteristic of the antenna.

A valuable feature of this antenna is that it does not permit the currents induced in its vertical elements to suffer loss through reradiation from its horizontal elements. Such loss could be accomplished only by the passage of the currents along the horizontal connections. Due to the plurality of voltage sources, the electrical disturb-

ances add in such a way that the current is in standing waves. Fixed current nodes occur in these standing waves at each multiple of a half wavelength measured from the open end: at the centers of the horizontal elements. Thus the net value of current in each horizontal is small at all times and is composed of disturbances which at either side of the node are opposite in sense. In directions perpendicular to the horizontals the radiations from the opposite currents cancel, at any appreciable distance. In other directions the fact that the currents are small and opposite makes radiation negligible. The symmetry of the antenna either side of R, moreover, causes the antenna to act as a whole about R in the same manner as

do the horizontal elements about the current nodes. This symmetry further assures cancellation of horizontal radiations.

Figure 2 shows one of the broadside antennas constructed at Netcong, New Jersey, for reception from England. It contains, in each of the two rows, twenty-four elements spaced a quarter wavelength apart. As was

shown before, a single row does not discriminate between broadside waves from opposite directions. To avoid the bi-directional characteristic which a single row would exhibit, the second identical row is spaced a quarter wavelength behind the first and so connected with it that the two differ in phase by a quarter period. The resulting unidirectional characteristic is shown by the plot in Figure 3.

A broadside antenna of this size delivers to the receiver a power greater by nearly forty times (sixteen decibels) than that delivered by a single, vertical, half-wave antenna. If static were distributed uniformly around the antenna, the improvement in the ratio of the signal power to the static power would likewise be nearly forty fold. When discrimination against directional static can be effected by use of the deep minima in the directional characteristic, still greater improvements in the signal-to-static ratio are possible. The variability in the apparent direction of received waves\* is of course a major factor in limiting the degree of directivity which it is useful to attempt. Within this limitation directional receiving antennas accomplish great increases in the efficiency of point-to-point radio systems operating on short waves.

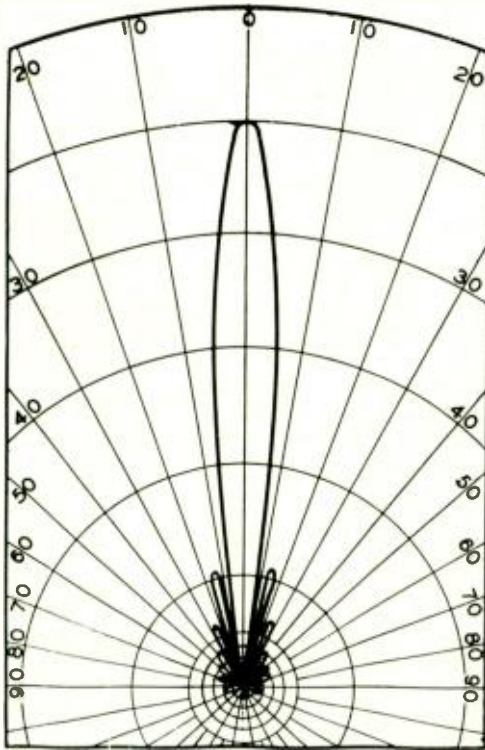

Fig. 3—Directional characteristic of Netcong antenna

\* BELL LABORATORIES RECORD, July, 1928, page 359.

---

# NEWS

*and Pictures of the Month*  
*including*  
*Notes of the Club*

---

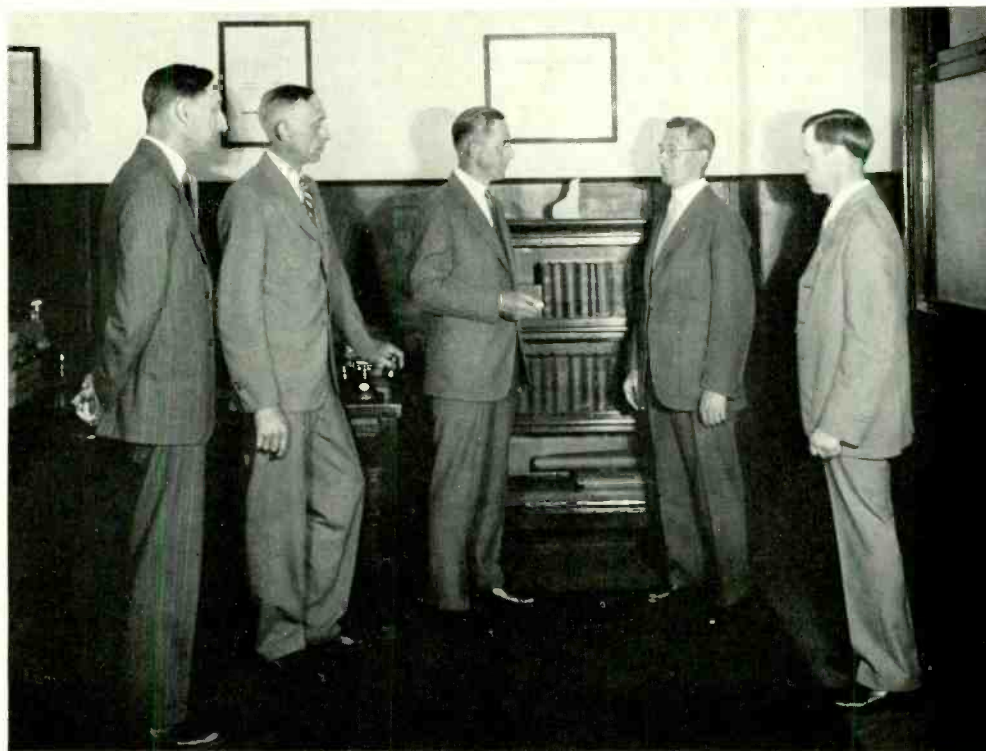

*Twenty years ago William Fondiller—Assistant Director of Apparatus Development—came to the Laboratories with a letter of introduction from Michael I. Pupin. Within his organization are three other men—W. J. Shackelton, H. H. Glenn, and J. C. Wright—who also completed twenty years' service in July. On the morning of July twelfth, R. L. Jones presented the 20-year service buttons to these four men in Mr. Fondiller's office and later in honor of the occasion entertained the group at an informal luncheon*



## News Notes

---

**T**HE EMPLOYEES' Benefit Committee has been delegated authority by the Board of Directors to bridge automatically all breaks in Bell System service of members of the Laboratories, when they complete ten years of continuous service before reaching the age of sixty-five years. The only exceptions are breaks which occur before the completion of six months of continuous service.

The Committee also has been authorized, at its discretion, to bridge, before ten years of continuous service have been completed, any break occurring for educational reasons, and any break of less than six months which occurs after the completion of six months of continuous service. Except in case of breaks for educational reasons, the discretionary authorities of the Committee will be used only in unusual cases after a thorough investigation of all the facts.

A. F. Weber, the Secretary of the Committee, will notify those members of the Laboratories who are affected, as soon as adjustments of their service records have been made.

\* \* \* \*

**DURING** the past year some four hundred members of the Laboratories have continued their studies through courses in one or another of the night schools of greater New York. Of this number about half are studying for a degree; and ten, shown in the accompanying photograph, received bachelor degrees this year.

At the Polytechnic Institute of Brooklyn, S. F. Farkas was awarded a Summa Cum Laude, an honor incorporated in its curriculum only this year; but a search of the records indicated no previous candidate with equally high average grades.

\* \* \* \*

**THE SIXTEENTH** meeting of the Telephone Pioneers of America will be held at Minneapolis on October 18-19.

\* \* \* \*

S. P. GRACE has returned from a two months' tour of the Pacific Coast where he delivered a number of lectures before various scientific and technical bodies. Great interest was shown in all of these talks. The attendance, mounting to several thousands in many instances and filling the halls to the overflowing, far exceeded any of the previous meetings held during the year by the societies. R. M. Pease was in charge of the demonstrations given at each of these lectures.

### SYSTEMS DEVELOPMENT

H. M. SPICER visited the Palmer Electric Company at Waltham, Massachusetts, to discuss proposed modifications in the design of the Palmer master switch used in panel machine switching.

C. BORGMANN went to Cincinnati for the purpose of investigating ringing conditions on switchboard cable.

H. D. BRUHN spent several days at Wilmington, Delaware, and James-



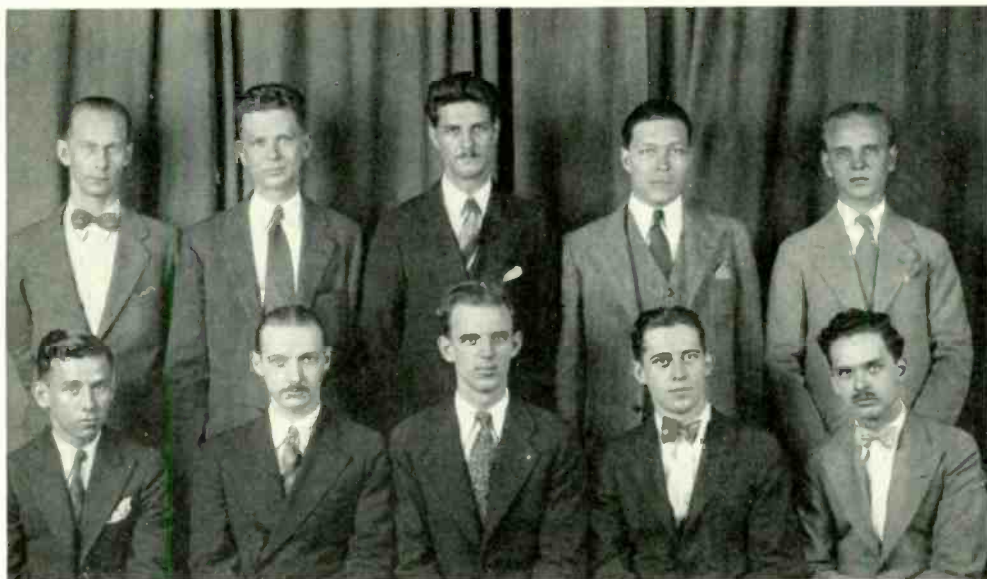

*Receiving bachelor degrees this year from night schools in the vicinity of New York are: standing, left to right—J. H. Bullwinkel, R. C. Williams, E. A. Krauth, M. A. Warren, and S. F. Farkas; seated—E. F. Ennis, G. Gottron, W. Kalin, O. C. Bleicher and J. R. Hefele*

town, New York, in connection with PBX problems.

CONFERENCES with Western Electric engineers required the presence of J. Irish and C. H. Achenbach in Hawthorne during the past month.

H. A. MILOCHE was at Cleveland to confer with engineers of the Ohio Bell Telephone Company on various projects concerned with the new Akron Toll Office.

DURING THE month F. S. Kinkead, H. H. Spencer, J. H. Sale, R. P. Jutson, and W. E. Burke visited Durham and Greensboro, N. C., and Greenville, S. C., to observe trial installations of recently developed apparatus on toll repeater stations.

L. M. ALLEN was at Chicago to observe the installation of the 701-A PBX at the joint warehouse of the Western Electric and Illinois Bell Telephone Company. While at Chicago he visited the Hawthorne plant and later on the same trip visited De-

troit, Jackson and Kalamazoo in connection with toll line dialing matters. He also stopped off at Cleveland for the purpose of undertaking circuit studies.

A TRIAL INSTALLATION of toll line dialing between Kalamazoo and Detroit, Michigan, was observed by L. M. Allen and J. Meszar.

C. W. GREEN, R. W. CHESNUT and J. A. MAHONEY went to Washington to view a new automatic pilot channel for carrier telephone systems. Tests along the line of this installation between Washington and Jacksonville are being made by W. F. Kannenberg, D. M. Terry and C. M. Hemmer.

R. A. LECONTE visited Allentown, and D. T. Osgood, Bedford, Pennsylvania, where tests are being made on program transmission over cable circuits.

A. F. BURNS, C. H. BIDWELL, J. M. DUGUID and C. W. VAN DUYN

visited Springfield, Massachusetts, and Syracuse, New York, where improved methods of supplying central-office tones are being tested.

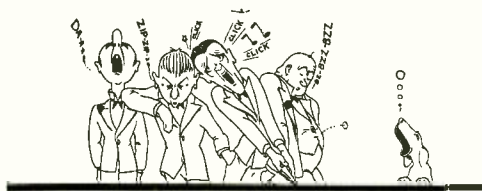

W. J. LACERTE and E. J. DONOHUE visited Syracuse, New York, where an improved out-trunk preselector is being tested. Mr. Lacerte also visited Gary, Indiana, where a newly devised number checking arrangement is under investigation.

M. E. KROM spent several days at Ellenville and Penn Yan, New York, on a study of subscribers' line ringing positions.

H. E. POWELL visited Jamestown, New York, where improved rural line service is under investigation.

V. T. CALLAHAN and F. F. SIEBERT have been at Cincinnati to investigate an improved method of starting gasoline engines.

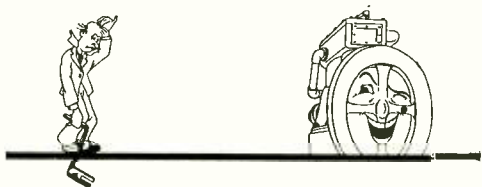

B. M. BOUMAN visited Gardner, Massachusetts, and Chicago on work connected with various improvements on operators' chairs.

#### PATENT

THE PATENT DEPARTMENT reports that E. W. Adams, W. C. Kiesel, E. C. Laughlin, I. A. McCordendale and G. H. Stevenson were at

Washington and J. G. Roberts was at Chicago in connection with the prosecution of patents during the period from June 7 to July 5.

#### OUTSIDE PLANT DEVELOPMENT

R. H. COLLEY visited the Forest Products Laboratory at Madison, Wisconsin, and conferred with members of the staff in regard to standard fiber strength values for poles.

IN CONNECTION WITH studies of preservative treatments on poles, particularly lodgepole pine poles, G. Q. Lumsden, D. C. Smith of the Amer-

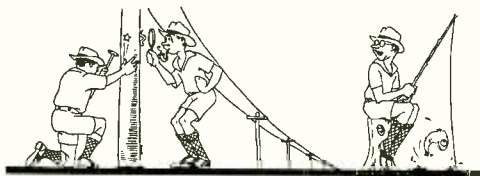

ican Telephone and Telegraph Company, and R. W. Lindsay of the Mountain States Telephone and Telegraph Company made an inspection tour of pole lines in Montana and Wyoming. C. H. Amadon was at Denver and Salida, Colorado, during the greater part of June to observe these preservative treatment methods.

C. D. HOCKER, C. S. GORDON, F. F. FARNSWORTH and E. M. HONAN attended the annual convention of the American Society for Testing Materials at Atlantic City.

F. F. FARNSWORTH has been in Florida to observe the wearing qualities of various paints used on Bell System motor vehicles.

C. S. GORDON's work on drop wire production took him to the plant of the New York Insulated Wire Company at Wallingford, Connecticut, to observe manufacturing methods. While on this visit he went to the Reliable Manufacturing Company's

plant at New Haven to investigate the manufacture of strand dynamometers.

#### INSPECTION ENGINEERING

G. D. EDWARDS and A. F. GILSON visited Brazil, Indiana, to discuss with several manufacturers of clay conduit matters concerning proposed inspection survey conferences.

W. A. SHEWHART presented a paper entitled *Basis for Analysis of Test Results* at the convention of the American Society for Testing Materials at Atlantic City.

R. M. MOODY visited the Gray Telephone Pay Station Company in Hartford, Connecticut, in connection with studies of coin-box telephone stations.

S. H. ANDERSON and I. W. WHITESIDE, Philadelphia Field Engineer, visited several telephone offices in the Pennsylvania area to investigate the operation of telephone power equipment.

H. W. NYLUND, St. Louis Field Engineer, recently visited Dallas, Oklahoma City, Cushing, and Tulsa, to conduct investigations of telephone equipment.

W. E. WHITWORTH, Omaha Field Engineer, was in New York to confer with members of the Department regarding field engineering activities.

#### APPARATUS DEVELOPMENT

J. R. TOWNSEND presented two papers at the American Society for Testing Materials meeting at Atlantic City. The first, *Physical Properties of Non-Ferrous Metals*, was written jointly by himself, W. A. Straw of Hawthorne, and C. H. Davis of the American Brass Company. It gave further information about the joint specification studies being made by

the Bell System and the American Brass Company.

The second paper was written jointly by Mr. Townsend and C. H. Greenall and described fatigue studies of non-ferrous metals in progress at the Laboratories to determine life characteristics of such materials used in telephone apparatus springs.

At this meeting H. A. Anderson presented the annual report of the Committee on Die Cast Metals and Alloys, of which he is Chairman. Over fifty committee members representing principal suppliers and users in the United States are cooperating in investigating die castings, many of which are used in the handset and other telephone apparatus.

Other members of the Department staff who attended the meeting were W. Fondiller, W. J. Shackelton, H. N. Van Deusen, J. M. Wilson, and F. F. Lucas.

H. N. VAN DEUSEN spent the week of July 8 at Hawthorne in conferences on various material problems.

C. H. GREENALL attended a conference at Kearny to establish standards for Rockwell hardness tests of sheet metals.

G. W. FOLKNER has been at Hawthorne working on various manufacturing problems on multiple banks.

D. C. LLOYD has been at Kingston, New York, conducting contact tests on pilot wire regulators for toll lines.

R. M. PEASE has returned from a two months' tour of the Southwest and the Pacific Coast where he gave demonstrations in conjunction with S. P. Grace's lectures.

J. G. FERGUSON read a paper *Shielding in High Frequency Measurements* at the summer convention of the American Institute of Electrical Engineers at Swampscott. S. J.

Zammataro also attended the meeting.

G. R. LUM visited the Philadelphia Instrument Shop in connection with development of vacuum-tube sockets.

R. V. TERRY and E. W. GENT visited the Olsen Testing Machine Company at Philadelphia to inspect a dynamic balancing machine there. While at Philadelphia they also visited the Bilgrim Machine Company.

PILOTED BY Thomas Durfee the Laboratories plane flew to Hartford where its 400-H.P. Wasp motor was given a general overhauling in the Pratt and Whitney shops. The work required several days to complete after which the plane was returned to its base at Hadley Field. The plane has recently rounded out a full year of service during which its engine-hour record has totaled over 400 hours.

A. B. BAILEY was at Weymouth, Massachusetts, where he supervised the installation of the transmitting equipment for station WEEL, the new 1000-watt broadcast station of the Edison Electric Illuminating Company. He also directed the installation of the 500-watt broadcasting equipment for the Tremont Temple at Boston.

J. C. HERBER is supervising the installation of the five kilowatt broadcasting equipment of Larus and Brothers Company of Richmond, Virginia.

THE CONVERSION of the equipment of the five kilowatt broadcasting station of the Zion Institute and Industries at Zion, Illinois, to crystal control was supervised by O. W. Towner. He also supervised the installation of the one kilowatt broadcasting equipment of the Toledo Broadcasting Company at Toledo.

F. A. HINNERS supervised the installation of the one kilowatt broadcasting equipment of the City of New York.

A PAPER entitled *Telephone Transmission Networks* by T. E. Shea and C. E. Lane was read at the Dallas meeting of the American Institute of Electrical Engineers.

#### RESEARCH

C. J. DAVISSON has been honored by election to membership of the American Philosophical Society and to fellowship in the American Academy of Arts and Sciences. With F. S. Goucher he attended a dinner given by the Research Corporation at the Century Club in honor of Professors Bergen Davis of Columbia and W. Heisenberg of the University of Leipzig.

AT THE ANNUAL meeting of the American Federation of Organizations for the Hard of Hearing of which Harvey Fletcher is president, a paper, *Audiometer Technique in Public Schools*, was read by J. B. Kelly. E. G. Shower also attended the meeting.

C. H. G. GRAY has returned from abroad where he attended meetings of the *Comité Consultatif International des Communications Téléphoniques à Grande Distance* at Berlin. While abroad he participated in conferences in London and Paris to consider questions concerning the Master Reference System for Telephone Transmission. A paper on this subject written by Mr. Gray and W. H. Martin of the American Telephone and Telegraph Company was presented by the authors at the meeting of the American Institute of Electrical Engineers at Swampscott.

L. H. CAMPBELL and A. E. SCHUH

spent several days at the plant of the Imperial Color Works at Glens Falls, New York, in carrying on investigations of color pigments and their incorporation into paint and lacquer products.

A. N. GRAY visited the Simplex Wire Company at Boston on matters concerning rubber covered wire.

L. E. KROHN, accompanied by D. W. Mathison of the Apparatus Development Department, was at Hawthorne on studies of manufacturing methods of 200-point step-by-step banks.

H. H. LOWRY visited the Jeddo-Highland Coal Company at Jeddo, Pennsylvania, in connection with the investigations which are being made of new sources of coal for use in transmitter carbon.

A. C. WALKER spent several days with the Eastman Kodak Company at Rochester in studying properties and uses of cellulose acetate.

IN COMPANY WITH J. J. Pilliod and A. B. Clark of the American Telephone and Telegraph Company, O. E. Buckley sailed on the S.S. "Nerissa" for St. Johns, Newfoundland. Their trip was made to observe the laying of a short cable which is to be used for a study of interference measurements in the vicinity of Trinity Bay. They were later joined by W. S. Gorton.

J. B. JOHNSON with E. O. Scriven and N. Insley of the Apparatus Development Department attended a

conference at the Nela Laboratories at Cleveland on lamps for sound film reproduction.

W. A. MARISON attended the summer convention of the American Institute of Electrical Engineers at Swampscott.

C. W. BORGMANN, J. M. Finch, A. N. Gray, C. L. Hippensteel, J. H. Ingmanson and A. C. Walker attended the American Society for Testing Materials convention at Atlantic City.

A PAPER *Apparent Modulation of Light by Films of Dielectrics on Cathodes of Alkali Metal Photoelectric Cells* was presented by A. R. Olpin at the joint meeting of the American Physical Society and the Pacific division of the American Society for the Advancement of Science held at Berkeley, California. While on the Pacific coast, Mr. Olpin visited the Crocker Research Laboratory in San Francisco and inspected the Farnsworth system of television.

C. F. P. ROSE is in Buenos Aires supervising the installation of transmitting and receiving apparatus preliminary to placing into operation the radio channel from South America to the United States.

#### PUBLICATION

P. C. JONES addressed a college training group of the Bell Telephone Company of Pennsylvania at Philadelphia. His subject was *The Functions, Accomplishments, and Prospects of Bell Telephone Laboratories.*

## *Bell Laboratories Club*

The silver trophy, "The Start," awarded to the company scoring most points in the men's competition: Won by the Bell Telephone Laboratories. The large silver cup awarded to the company scoring the most points in the women's competition: Won also by the Bell Telephone Laboratories. Such was the share of prizes garnered by the Laboratories as the last smoke of Starter Murchison's gun cleared away in the second annual track and field meet of the Bell System Athletic League at Erasmus Field, June 22.

Two hundred and thirty men and women representing fourteen branches of the Bell System in the metropolitan district competed for the prizes in the twelve events.<sup>1</sup> The Laboratories men scored a total of twenty-one points and the women sixteen.

The West Street men did not place in the shorter distances which were

the 100, 220, and the 440 yard dashes but in the 880 yard event Bonilla broke the tape twenty yards in front of his nearest rival and scored five points for our team. Moffat came in third in this race, adding an additional point to our total.

In the shot-put Vesely added three points more and Pasanen who had led throughout the trial jumps had to be content with second place in the broad jump. Coincidentally enough, he was beaten in the last jump by the same man from the New York Telephone Company, Long Island, who defeated him on the last jump in 1928.

The high jump again was won by New York Telephone Company, Long Island, with Nelson of the Laboratories landing in third place.

After a bad start in the mile relay, our team, by supreme effort, managed to finish in second place.

Again this year the tug-of-war proved to be the feature of the games. In the trial pull, our team, coached and trained by Bill Calmar, defeated New York Telephone, Eastern Manhattan, with ease, but in the finals it was not until the last five seconds of the three minute pull that we were able to take the event from the New York Telephone Company, Long Island. Throughout the entire three minutes the tape see-sawed across the center mark. Considerable interest and rivalry was shown in this event and amidst the greatest excitement ever witnessed at a Bell System meet, Calmar's strong men pulled the tape on their side one-quarter of an inch,



*Bonilla wins the eight-eighty for the Laboratories*

just an instant before the gun was fired announcing the end of the pull. C. T. Boyles, judge for the event, declared the Laboratories the winner.

Last but not least we want to tell about the creditable showing of our women athletes—and there is much to tell. For five years Marie Boman has stood out as the best woman athlete in the Bell System competition, and on June 22 she again demonstrated that she can beat the best that the associated companies have to offer. In the trial heats for the sixty yard dash she had things all her own way, and then won the finals in the exceptionally good time of seven and nine-tenth seconds. Miss Smith, also of the Laboratories, finished second, in eight seconds flat.

Miss O'Neil finished in second place in the basketball throw; this event being won by Miss De Martini of Bronx-Westchester who repeated her victory of last year.

The quarter-mile relay for women was also won by the Laboratories. Miss Boman, running as anchor, demonstrated that she still had considerable speed left after her previous runs and won this event for her team by a fifteen yard lead.

#### POINT—SET—MATCH

We admit that the English Singles Tournament at Wimbledon is the tennis classic of the year. Nevertheless we can claim that our recently completed Singles Tournament aroused no less keen competition. Fifty-eight men in all took part in the tournament which resulted in Sam Durand being crowned singles champion of the Club.

Many exciting matches were played and numerous upsets took place in the early rounds. K. S. Johnson, who

was seeded as Number Two man, was eliminated in the third round by Tolman, and Lamoreaux, Number Four man, was put out in the second round by Langborgh.



*Marie O'Neil wins second place in the basketball throw*

J. C. Kennelty deserted the golf committee temporarily to serve on the tennis committee and was kind enough to make arrangements for the semi-final matches which were played at the Marine and Field Club at Bath Beach. In the semi-final round Durand defeated Elliott in three straight sets, 6-1, 6-3, 7-5, but it took Entz five sets to eliminate Tolman, who, after losing the first two sets, 6-2 and 6-3, staged a come-back, winning the third and fourth sets, 5-7 and 3-6. The strain, however, was evidently too much and Entz won the fifth, 6-0.

The finals were played on the Notlek Courts, Tuesday evening, June 25, and after four hard-fought sets



*Nelson scores in the high jump*



*Pasanen wins 3 points in the broad jump*

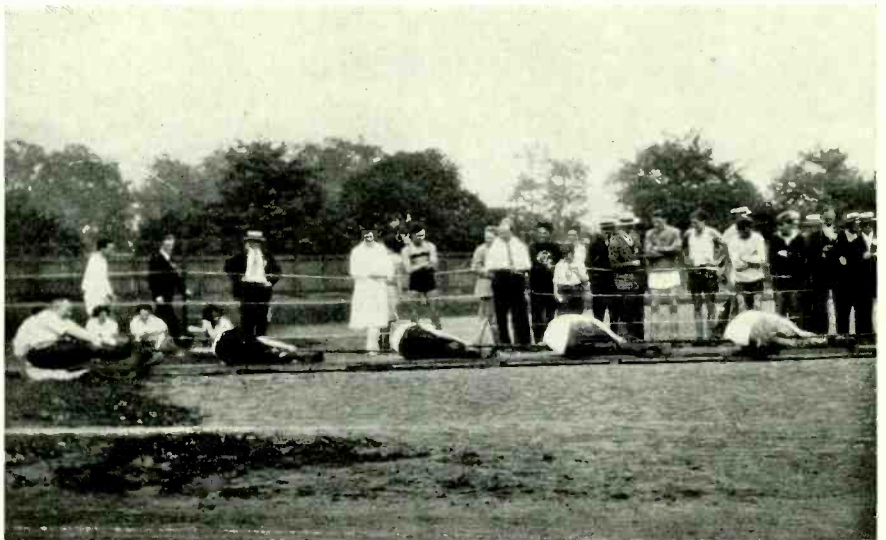

*New York Tel., Eastern Manhattan—*





*The winning relay team: Marie Boman,  
Emily Smith, Katherine Fenton, Marie  
O'Neil*



*Marie Boman finishes first in the sixty-  
yard dash*



*loses to the Laboratories in a trial heat*

Durand was declared the winner. The score of 6-3, 6-4, 4-6 and 6-1 does not tell the true story of the match. Every point of each set was bitterly contested and many times the games went to deuce before game point was scored. Both players were very cautious in the first two sets but opened up in the third. It was in this set that Entz made his bid for victory, winning the set 4-6. After the ten minutes rest period at the end of the third set, Durand came back on the court, cut loose with a brand of tennis that Entz could not handle, and won the fourth set and match.

From the caliber of tennis displayed by our players in this tournament we feel confident of placing a successful eight-man team in outside competition. The Club doubles championship will start on Saturday, September 7. For information regarding entrance in this tournament consult W. Kuhn.

#### GLEE CLUB

The Laboratories Glee Club assisted in a song recital given by the pupils of Vere Richards before a large audience in Carnegie Hall.

#### GOLF NEWS

On Saturday, June 29, the Laboratories held its first golf tournament with the New York Telephone Company, Manhattan Area. Two eight-man teams competed in this tournament, which was held on course number five of the Salisbury Country Club and resulted in a victory for the Laboratories team by a score of 6½ to 5½. The scoring was based on match play with a point for each match and a point for low ball in each foursome. The results of the matches follow:

Kramer, N.Y.T., defeated Hillier, B.T.L., 3 up.  
Groves, N.Y.T. defeated Thorn, B.T.L., 6 up.  
Bittner, N.Y.T. defeated Kellogg, B.T.L., 5 up.

Seaman, N.Y.T. defeated Wood, B.T.L., 3 up.  
Roberts, B.T.L., defeated LeCluse, N.Y.T., 8 up.  
Kidde, B.T.L., defeated Morgan, N.Y.T., 5 up.  
Clark, B.T.L. defeated La Voie, N.Y.T., 8 up.  
Burwell, B.T.L., defeated Brody, N.Y.T., 8 up.

This match is the first of a number of similar tournaments which will be held with teams from other commercial houses and associated companies in the metropolitan district.

In winning this tournament from the New York Telephone Company, the Laboratories' team is awarded a trophy to be retained for one year.

On Saturday, July 13th, at the Salisbury Country Club, the Laboratories' golf team made a clean sweep of their matches with the golfers of the International Telegraph and Telephone Company. All eight men playing for the Laboratories won their matches and also won the one point allowed for best ball in each foursome, making the final score 12-0.

From the caliber of golf displayed by our team, we feel sure that these men can hold their own with the best from associated companies and commercial houses in the metropolitan district. J. G. Roberts defeated his opponent nine up and eight to play, turning in an eighty-one which was low for the tournament.

The tabulation follows:

- W. L. Downing defeated E. Wagenstein 5 up, medal score 87.
- E. H. Clark defeated F. C. Shann 4 up, medal score 87.
- G. E. Kellogg defeated D. McDonald 5 up; medal score 86.
- J. Hillier defeated C. Wagenstein 5 up, medal score 90.
- H. W. Wood defeated G. H. Gray 5 up, medal score 86.
- J. G. Roberts defeated J. Goodrich 9 up, medal score 81.
- G. T. Lewis defeated S. Babcock 5 up, medal score 86.
- J. C. Kennelly defeated W. J. Brown 5 up, medal score 94.

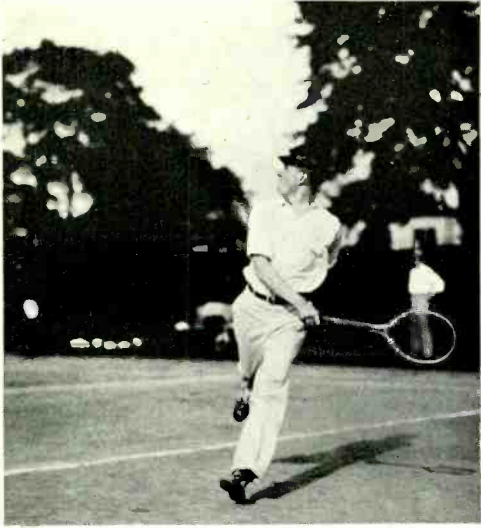

*Tolman, semi-finalist*

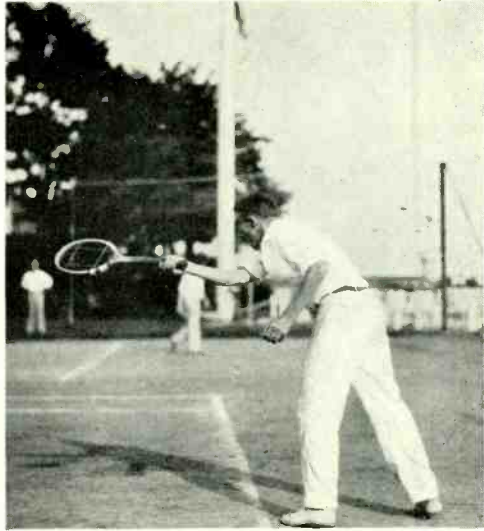

*Elliott, semi-finalist*

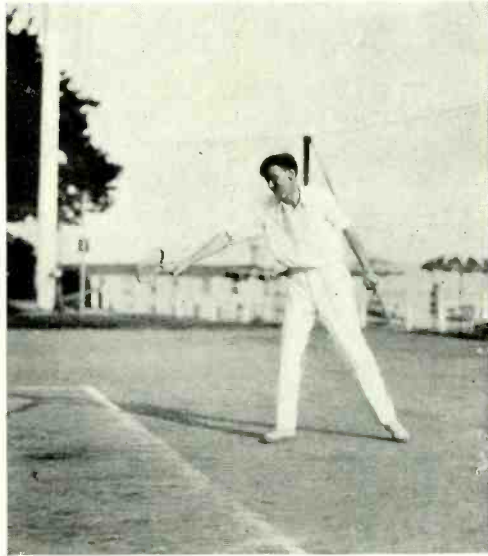

*Durand, winner*

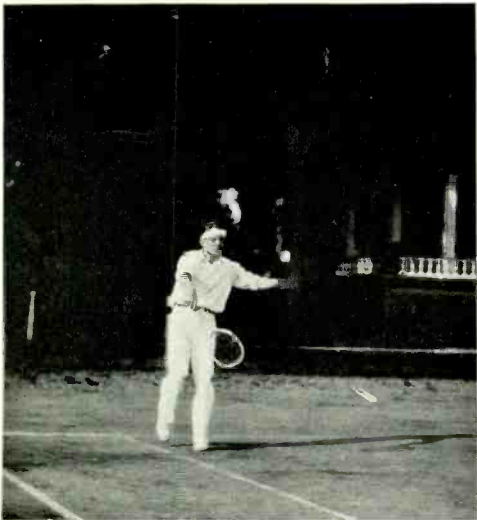

*Entz, runner-up*



## Contributors to this Issue

---

A. A. OSWALD received from Armor Institute of Technology the B.S. degree in 1916 and the E.E. degree in 1927. With the Laboratories since 1916 he has been continuously engaged in its successive radio projects. He took part in the development of long-wave transatlantic telephony, and was at Montauk for the early transmission experiments. During the World War he had charge of the field-testing of airplane-telephones for the Signal Corps, and devised a method of radio-control for airplanes in flight. From 1919 to 1922 he assisted in the development of ship-to-shore communication. Since then he has been concerned with the long-wave and short-wave transoceanic systems.

M. E. FULTZ received the E.E. degree from Pennsylvania State College in 1914. From two years with both the Marconi Wireless Company and the International Radio Company he received wide radio experience, then joined these Laboratories in 1920. He has participated in the ship-to-shore, long-wave (at Rocky Point) and short-wave radio-telephone developments.

E. B. FERRELL received the B.A. degree in 1920, and the following year the B.S. degree in electrical engineering, from Oklahoma University. After three years as instructor in mathematics there, he received the M.A. degree, then came to the Research Department of these Laboratories to work on short-wave radio

problems. He has had a large part in the development of the transmitters at Lawrenceville.

E. J. STERBA received the B.E. degree from the University of Iowa in 1920, and joined the Research Department of these Laboratories in the fall of that year. Since 1922 he has been engaged in the development of radio antennas, especially short-wave transmitting antennas of the directive types.

F. A. POLKINGHORN received the B.S. degree in electrical engineering from the University of California in 1922. After two years with the Naval Radio Laboratory at Mare Island, and a year in San Francisco engineering the development and manufacture of vacuum tubes, he joined the Pacific Telephone and Telegraph Company for transmission and plant methods work. Since 1927, when he was transferred to these Laboratories, he has worked on radio transmission and reception.

AFTER three years with the United States Navy, E. Bruce entered Massachusetts Institute of Technology in 1920, and joined the Engineering Staff of the Clapp-Eastham Company in 1922. In 1924 he received the B.S. degree in electrical communications and came to the Research Department of these Laboratories. Mr. Bruce has been principally concerned here with the development of short-wave field-strength measuring equipment and directive receiving-antenna systems.