

BELL LABORATORIES RECORD

LIBRARY
JAN 15 1932

U. S. PATENT OFFICE



THE TIME FACTOR
IN TELEPHONY

O. B. Blackwell

—
HYDROGENIZED IRON

P. P. Cioffi

—
TELETYPEWRITER
SERVICE

G. A. Locke

JANUARY 1932 VOL. 10 No. 5

BELL LABORATORIES RECORD

Edited by the Bureau of Publication:

PAUL B. FINDLEY

Managing Editor

PHILIP C. JONES

Associate Editor

Board of Editorial Advisors:

O. E. BUCKLEY, W. FONDILLER, H. A. FREDERICK,
O. M. GLUNT, H. H. LOWRY, W. H. MATTHIES,
JOHN MILLS, D. A. QUARLES, J. G. ROBERTS,
W. B. SANFORD, G. B. THOMAS, R. R. WILLIAMS

BELL TELEPHONE LABORATORIES, INCORPORATED
463 West Street, New York, N. Y.

Articles in this Issue

Time Factor in Telephone Transmission	138
<i>O. B. Blackwell</i>	
Nation-Wide Teletypewriter Service	144
<i>G. A. Locke</i>	
Coal for Transmitters	150
<i>J. R. Fisher</i>	
Adjustable Frequency Generator for the Voice Range	155
<i>J. R. Power</i>	
Hydrogenized Iron of High Permeability	159
<i>P. P. Cioffi</i>	
Mortar Bandage Conduit Joints	164
<i>J. M. Hardesty</i>	
The Lapel Microphone	170
<i>W. C. Jones</i>	
Portable Balance Unit for A-C Precision Bridge	173
<i>S. J. Zammataro</i>	

BELL LABORATORIES RECORD

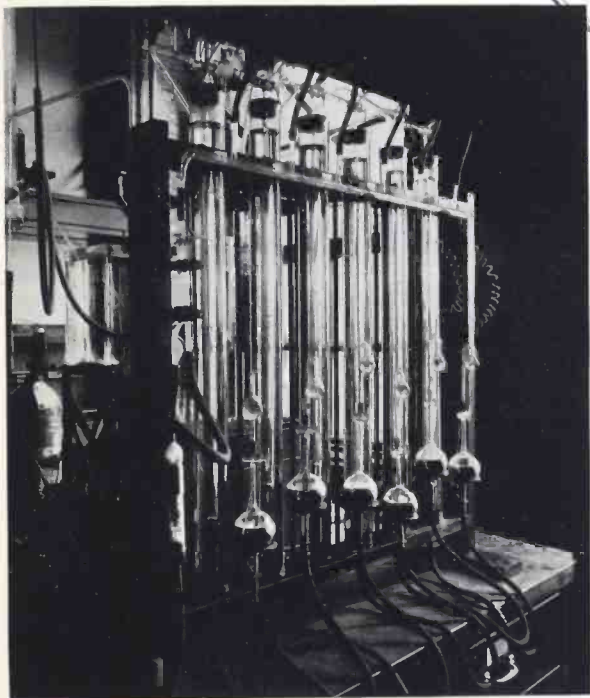

Apparatus developed by the Chemical Department for measuring absorption of oxygen by organic solids such as rubber and asphalt

VOLUME TEN—NUMBER FIVE

for

JANUARY

1932

The Time Factor in Telephone Transmission

By O. B. BLACKWELL,

American Telephone and Telegraph Company

UNTIL comparatively recent years the telephone engineer could assume for all practical purposes that speech was transmitted instantly between the ends of telephone circuits; and he needed to give little attention in his problems to the time of transmission. The rapid extension of the range of commercial telephony and the use of long telephone cables have changed the situation and emphasized problems of time in telephone transmission, which are of large technical interest and difficulty. Speed and time of transmission, as a result, are receiving more consideration—a fact readily verified by a glance at the papers on transmission published in recent years.

Time enters telephone problems because the speed of transmission of electrical impulses has a finite value. Whenever a change in applied voltage is made at one end of a circuit, some evidence of the change is transmitted to the receiving end at the speed of light. Except in radio, however, no

sufficient action is ordinarily transmitted at this speed to be of use, and speed so defined is largely of theoretical importance.

The speed that the engineer generally has in mind while considering electrical transmission is that at which the crests and troughs of the waves pass along a line when a single-frequency potential is continuously applied at the sending end. This is usually referred to as the "speed of phase transmission in the steady state." In the transmission of intelligence, however, the potential is not a steady single frequency, but varies in accordance with the signal being transmitted, as is illustrated by the sending of a dot over a carrier telegraph channel. In that case a voltage of a single frequency is applied to the circuit for a short interval and then removed; with the result that a spurt of energy travels along the line. The speed with which it travels is the speed which is of importance to the transmission engineer, whether concerned with telegraphic or telephonic signals.

Since speed of transmission is usually not the same for all frequencies, the narrow range of frequencies to which it applies must always be specified. It is then defined approximately as the speed with which a dot impulse travels when caused by the application of a voltage of frequency corresponding to the mid point of the frequency range. Speed so defined will differ considerably for different

Type of Circuit	Approx. Speed in Miles per Second
Cable circuits loaded with 88-mh. coils at 3,000 foot spacing....	10,000
Cable circuits loaded with 44-mh. coils at 6,000 foot spacing....	20,000
Cable pairs of non-loaded 16 B. & S. gauge	130,000
Non-loaded open-wire pairs....	180,000
Radio	186,000

Fig. 1—Typical transmission speeds for various types of circuit

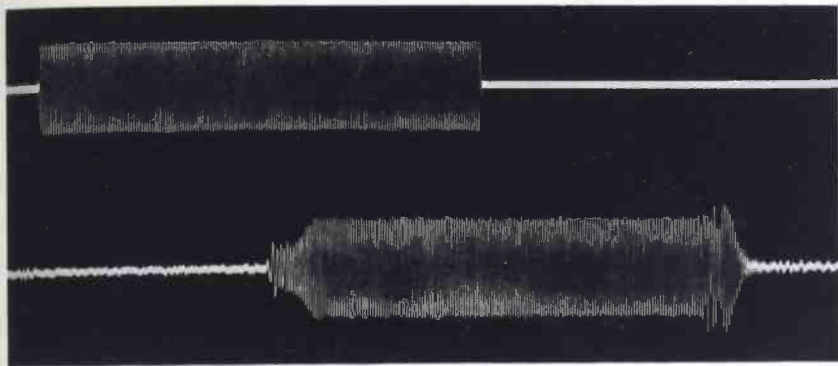

Fig. 2—Illustrating delay distortion where the higher frequencies are delayed more than the lower

types of circuits. It is the same as the speed of light in the case of radio and also for the ideal and limiting case of a pair of open wires of zero resistance in free space, separated from all other conductors, and without leakage.

Actual non-loaded open-wire circuits, however, transmit at a slightly lower speed as is shown in the table of Figure 1. The retardation existing comes largely from the glass insulators and the resistance of the wires which causes an effective increase in inductance. The greater retardation of cable circuits arises from the increase in capacity between wires, due to the necessity of using a certain amount of solid dielectric, and particularly to the increase in inductance from loading coils which are inserted to reduce attenuation. In operation some further retardation is caused by apparatus necessarily inserted at the terminals and at intermediate points along the circuit. Delays because of such apparatus will, in general, reduce the speeds of Figure 1—which are for bare circuits—by from 10 to 25 per cent.

These transmission speeds are low

enough for certain types of circuits to produce an appreciable time of transmission for some of the longer lines of the present day. Several types of problems arise in telephone transmission as a result. The most direct effect is the delay—by an interval equal to twice the transmission time of the circuit—between the asking of a question by a speaker at one end of the circuit, and his reception of the reply.

Telephone engineers have devoted considerable attention to the effect of delays of various amounts, using in their study artificial delay circuits of several types, electrical, mechanical, and acoustical.* They have found it possible to talk fairly satisfactorily over circuits with time delays as great as .7 seconds in each direction, but recommend for commercial service delays of only about a third of that amount.

With non-loaded construction, transmission speeds are high enough so that conversations could be carried on between the most remote places on the earth without difficulty. For loaded circuits, however, the situation is

* BELL LABORATORIES RECORD, May, 1931, p. 430.

different. With a 4,000-mile circuit, representing perhaps the greatest wire-line distance between any two points in this country, a two-way delay of 0.8 second would be introduced by using the slowest construction listed in the table.

Another direct effect of the time of transmission on telephone conversation is a distortion of the speech waves due to unequal velocities for different frequencies. The effect of this is to introduce transients which make the received wave of different form from that sent out. This distortion is pronounced only when the circuit is long compared to the wave length of the frequencies to be transmitted. For electrically long circuits care must be exercised in their design to insure that the times of transmission for all frequencies of the transmitted band are sufficiently alike to avoid objectionable effects.

When any wave shape is applied to a circuit, the transmitted wave can be mathematically expressed as the sum of an infinity of sinusoidal waves of frequencies ranging from very low to very high values. If then a sinusoidal wave of some single frequency is suddenly applied to the sending end of a line, the effect may be considered as due to an infinity of sinusoidal waves

so proportioned and phased as to add up to zero until the instant of application of the wave, and at that instant to equal the steady-state value. These component waves are propagated over the line individually, each with a definite velocity. If the transmission speed of the line is the same for all frequencies, the overall wave shape will be the same at the receiving as at the sending end. If the velocity is not independent of frequency, more or less distortion will accompany the establishment of the wave.

Distortions produced by delay are well illustrated by oscillograms showing various types of impulses as they are sent and as they are received. Figure 2 shows such oscillograms for a spurt of 1,600-cycle current applied to and received from a loaded circuit with delays in the upper part of the transmitted band fairly large compared to those in the lower. It will be observed that because there is a general delay for all frequencies no discernible effect reaches the receiving end till a definite time after the application of the current at the sending end. Because of smaller delay, the components of lower frequency arrive first, and only after a definite time does the received spurt resemble the applied form. At the end of the spurt

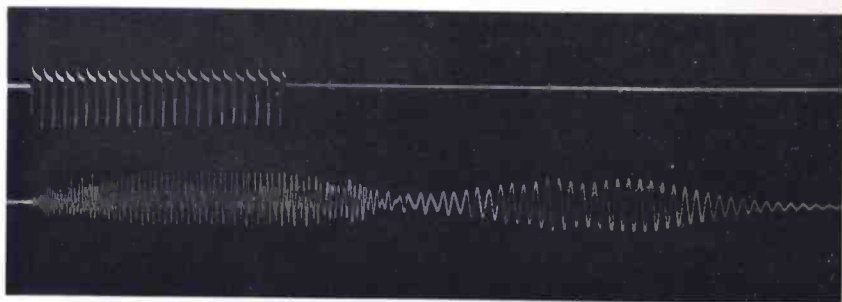

Fig. 3—An example of delay distortion when the lower frequencies are delayed more than the higher

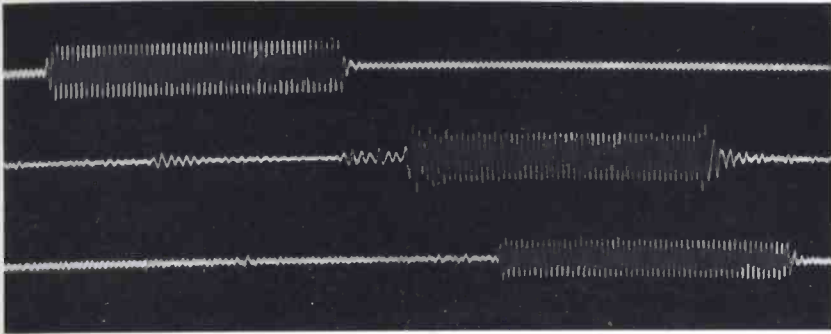

Fig. 4—Delay distortion may be corrected to a large extent by the use of delay equalizers

somewhat similar distortion occurs except that the higher frequencies, because of their greater delay, form the tailing-off section.

When the frequency-delay characteristics of a circuit are opposite to those applying to the last illustration, that is when the delay is greater at the low frequencies and less at the high, the effect is quite different as shown in Figure 3. The applied current in this case was of 200 cycles, but contained many harmonics. Here the high frequencies are received first and the low frequencies enough later to give the appearance of a double spurt of current.

It is possible to correct for distortions of this kind by the insertion of proper networks. In Figure 4 for example, are shown three oscillograph records of a 1,000-cycle current sent over 600 miles of composited, 19-gauge, loaded side-circuit. The upper line shows the applied spurt; and the middle line, the received current. The effect of delay distortion at the beginning and end of the spurt is plainly evident. The last line shows the received current when delay correcting networks are employed. By their use the transients at the beginning and

end of the spurt are almost completely eliminated although the delay in the reception of the signal has been somewhat increased.

Still another result of the existence of appreciable times of transmission is the production of echoes caused by reflection of electrical energy at points of discontinuity in the circuit. Some of them return to the receiver of the talker's telephone so that if the effects are severe he may hear an echo of his own words. Others enter the receiver of the listener's telephone and cause an echo to follow the direct transmission.

Such reflections occur, of course, regardless of the magnitude of the time of transmission, but they are usually considered as echoes only when there is an appreciable delay in the transmission. The seriousness of the effect is thus a function of both the time delay and the loudness of the echo. Although echo effects occur in all actual telephone circuits, it is only when the circuits are long enough to require a number of repeaters that they become serious. The length of such circuits makes the echoes appreciable, and the repeaters, because they overcome the high attenuation in the

circuit, make the echoes even louder.

The most important points of discontinuity are at the ends of the circuit since echoes from these points have the longest distance to travel and thus are delayed the most. In four-wire circuits these are the only points of discontinuity, but successive echoes may occur, circulating several times around the circuit as shown in Figure 5. Reflections occur at each end of the line at the balanced transformers which join the two separate one-way circuits, comprising the line, to the wires running to the subscriber's set. They are caused by imperfect balances between the networks, *N*, and the subscriber loops. The more accurately networks simulate subscriber circuits the less applicable will be the echoes, but it is impracticable to obtain perfect balance in an economical telephone plant.

In a long two-wire circuit, because of the use of the balanced transformers at each repeater, many more echo paths are possible. Although echoes can affect both talker and listener if pronounced, they generally have the greatest effect on the talker who may gain an uneasy feeling that the listener wishes to break in on the conversation.

Although time of transmission is thus in many ways something to be compensated and corrected, it is used to advantage in certain very long circuits. Here, in the form of delay circuits, it serves as an auxiliary to switching devices employed for preventing both the building-up of undesirable echoes and, in long radio telephone circuits, the occurrence of instability or the setting up of oscillations. An arrangement used at the terminal of the long-wave transatlan-

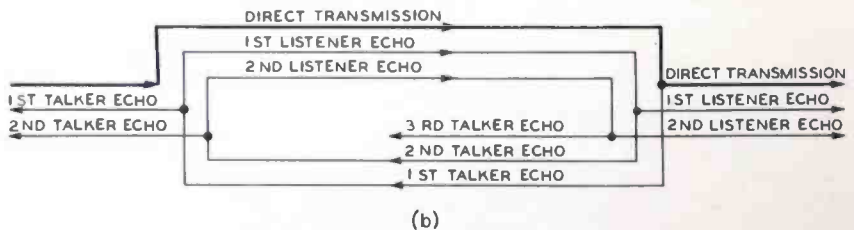
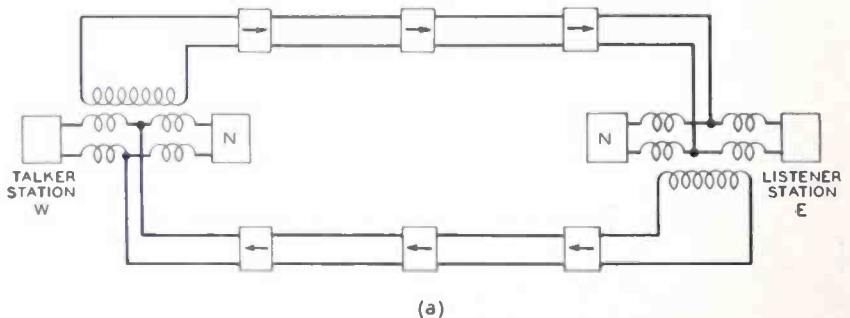

Fig. 5—Although echoes occur only at the ends of a four-wire line, they may circulate around the circuit several times

tic channel has already been described in the RECORD.* The purpose of such devices is to render inoperative transmission in the direction opposite to that of the speech waves going over a circuit at a particular instant.

Another effect of the time of transmission is the phenomenon of fading in radio, due to trains of waves arriving simultaneously at the receiver over two or more paths which have different times of transmission. These trains of waves from the transmitting station are received sometimes in phase agreement, strengthening, and alternately in opposition, weakening,

* RECORD, November, 1927, p. 80.

the received signal. Although mentioned here for completeness, this phenomenon is beyond the scope of this article which is limited to conditions holding when not more than one path is employed for transmission in each direction.

There are, of course, other effects of the time of transmission of electrical currents. For telephone circuits, however, the major effects have been covered. For the most part the delays are short, but with the prospects for talking over ever increasing distances, opened up by modern developments, they promise to play a part of continually increasing importance.

What Can I Sell?

The results thus far in the Telephone Sales Campaign demonstrate that successful selling is dependent in large part on recognizing sales opportunities. Below are some illustrations of sales opportunities and typical sales.

LOCATION	SALE
1. Residence not having telephone service	1. Main station service
2. Two-floor residence with single telephone	2. One or more extension stations
3. Residence with party line service	3. Individual line service
4. Large residence having one or two telephones	4. Additional extensions, wiring-plans, or 750-A PBX
5. Business, shop, office, store which does not have telephone service	5. Main station, public or semi-public service
6. Business (or residence) on calls to which one frequently encounters busy reports	6. Auxiliary lines or additional PBX trunks
7. Business where executives have only one PBX extension station	7. Additional PBX extension lines with wiring plan providing pick up by secretary
8. Business office or store where several employees use the same extension station frequently	8. Sell additional PBX station
9. Members of firm or family whose names are different from that now listed	9. Sell additional listing
10. For the aid of persons who are hard of hearing	10. Deaf set (23-A amplifier) if trial proves it to be helpful

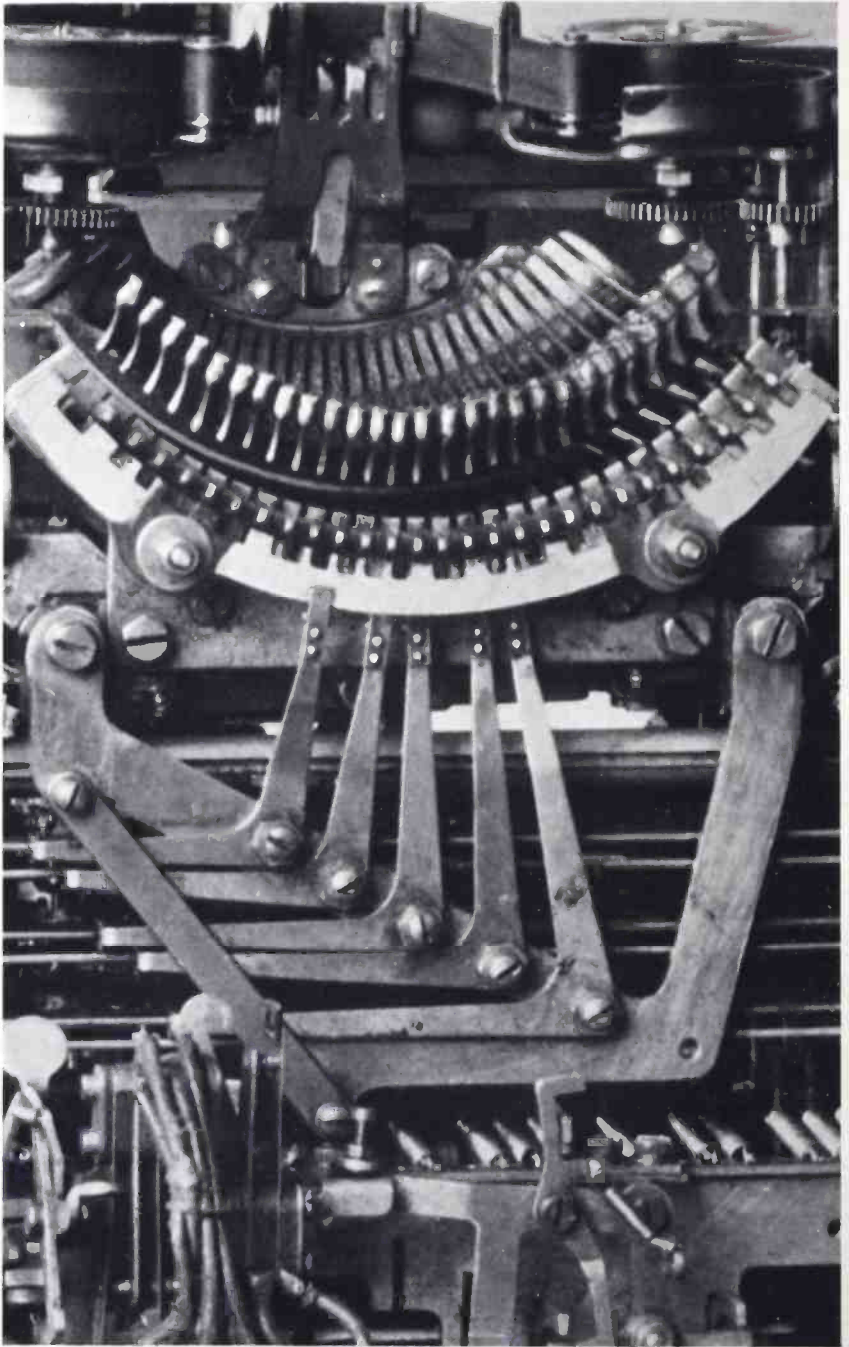

Nation-Wide Teletypewriter Service

By G. A. LOCKE
Telegraph Development

A COMMUNICATION service which offers the flexibility of telephone service in the transmission of the written word was made available November 21, when the American Telephone and Telegraph Company and its associated companies announced the inauguration of teletypewriter switching service.

The teletypewriter* transmits typewritten messages electrically over wires, so that whatever is typed at one end of a circuit appears, practically at the same instant, at the distant end, also in typewritten form. Teletypewriters have been in extensive use for some years in connection with private wire service contracted for by large business concerns having branch offices, banks, brokers, press associations, police departments, air transport lines and others.

In order to provide the new service, teletypewriter exchanges will be established at various points throughout the country so that a subscriber to the serv-

ice may transmit written messages directly to any other subscriber, anywhere, at any time. In other words, this makes possible for the typewritten word a nation-wide, inter-connecting service similar to that which the telephone system now provides for the spoken word. This new service is a "two-way" service, permitting inquiry



Fig. 1—Anyone who can operate a typewriter can operate a teletypewriter

* RECORD, Sept., 1926, p. 3.

and reply to be made immediately on the same connection.

A conducting pair is brought to the premises of each subscriber to the new service, much as for a telephone, and is there connected to a teletypewriter. Again, as for the telephone, the subscribers' loops terminate in teletypewriter exchanges which are interconnected by toll lines. Thus for

the most part the system is composed of equipment standard in pre-existing practice. The chief novelty is the central office switchboard.

This board, known as "Teletypewriter Switchboard No. 1," has been modeled after telephone switchboards, but contains many features peculiar to teletypewriter service. A section of the laboratory model of the board

is shown in Figure 1. Most evident is the substitution, for the operator's telephone set, of an operator's teletypewriter on the keyshelf of the board. Like the subscribers, the operators communicate over the system exclusively by printing equipment. The switchboard will be used initially for combined inward, outward and through service, but it has been designed so that it can be separated into inward, outward and through boards.

When a subscriber presses the "call" key (Figure 2) on the right hand side of his teletypewriter, the machine is put in operation and at the switchboard the calling lamps light over the jacks in the subscriber's multiple. One or more of those operators before whom the lamps are lighted answer by plugging into the subscriber's jack with the rear cord of an idle cord circuit, and

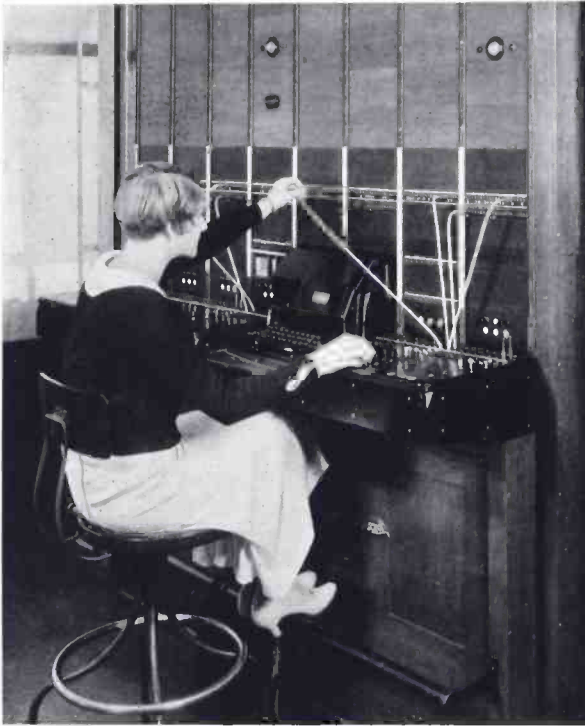

Fig. 2—At the board in the Graybar-Varick laboratories which demonstrated the commercial feasibility of the new service, Miss Ann Barioni, of the Telegraph Development group, shows how a call is put through. Conspicuous differences between teletypewriter and telephone switchboards are the replacement of the operator's telephone set by an operator's teletypewriter, and of the "busy" tone by a large "busy" lamp which, in the case of the board shown above, is mounted over the multiple

throwing the typing key in the cord circuit, which brings the operator's teletypewriter into the circuit. Only the first operator who plugs in obtains the line, and it is apparent to the other operators that they have not obtained the line, because the busy lamps over their teletypewriters light, and because their teletypewriters remain inoperative.

Having obtained the line, the operator types "OPK" on her teletypewriter, and this signal appears on the subscriber's teletypewriter. The subscriber then types the number of the desired station, and the operator, before whom the number is printed, proceeds to complete the call. If it is a local call, she tests the called multiple for busy by touching the tip of the front cord to the sleeve of the called subscriber's jack. If the line is busy, the busy lamp over her teletypewriter lights and she types a "busy" report to the subscriber.

If the line is not busy, she plugs the front cord into the called subscriber's jack and operates a ringing key connecting twenty-cycle ringing to a standard ringer at the called subscriber's station. Plugging in the cord lights a supervisory lamp associated with that cord. Operating the ringing key extinguishes this light and lights a ringing-guard lamp. The ringing on the cord is automatic, and the guard lamp remains alight until the subscriber answers. Accordingly the operator can retire from the circuit and complete other calls, for there remain definite indications of which cords are being used for ringing, and of whether the subscribers have answered.

A subscriber answers by pressing the "answer" key on the right hand side of the teletypewriter, thus starting his motor, removing the ringing,

extinguishing the ringing-guard lamp, and connecting the subscribers together for operation in either direction. When the communication has been completed, the originating subscriber sends a "stop" signal by press-



Fig. 3—The teletypewriter both sends and receives, producing records of all messages at both ends of the call. The only special controls which must be added to the standard teletypewriter to equip it for the new service are three push-button keys for "call," "answer," and "recall," mounted on the right hand side. The box behind contains the ringer, and relays associated with the push-button keys

ing the "FIG" key and the "STOP" key on the keyboard of the teletypewriter. This signal stops the motors of both subscribers' teletypewriters and illuminates the supervisory lamps in the cord circuit at the board. The operator then pulls down the cords.

At any time during his call a subscriber can recall the operator by pressing the "recall" key at the right hand side of his teletypewriter, thus causing the supervisory lamp in the cord circuit to flash repeatedly. The operator can go in on the line by

plete, the operator tells the calling subscriber to proceed, and retires from the circuit.

When a subscriber desires connection with a distant city, the operator plugs into a toll-line jack shown to be idled by an idle-line indicating lamp.

She calls over this line by the ringing key which now simply opens the line for a short period, thus lighting a calling lamp at the distant city. The distant operator plugs in, operates her typing key, and types the name of her city. On receiving the called number, she completes the call as for a local connection. The "stop" signal lights supervisory lamps in both cities and both operators pull down their cords.

Calls to a city not directly accessible from the originating point are built up through intermediate offices as

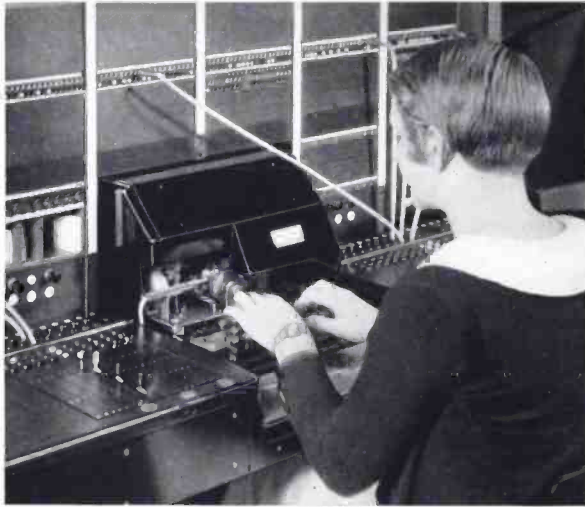

Fig. 4—In each cord circuit are (front to back) a typing key, a splitting key, a ringing key, an unattended-service and toll-signal key, a supervisory lamp for the front cord, a ringing-guard lamp, and a supervisory lamp for the back cord

merely throwing the typing key in the cord circuit.

One of the most interesting features of the system is that it provides for unattended service for those subscribers who contract for it. Wherever this arrangement has been made, if a called subscriber does not answer, the operator asks the calling subscriber if he wishes to leave his message. If he does, she presses a push-button key in the cord circuit, which starts the motor at the absent subscriber's teletypewriter and extinguishes the ringing-guard lamp. Knowing thus that the connection is com-

plete for a single city-to-city toll connection. To give the disconnect signal to the intermediate offices, the originating operator presses the unattended-service key and removes the toll cord. The supervisory lamps then light at the through points. Any operator can recall the operators participating in a toll connection by pressing the unattended-service key while the toll cord is up, thus causing lamps to flash at all intermediate points.

A unique service which the switchboard supplies is the conference connection, for subscribers who wish simultaneous connection with more than

one other subscriber or who wish to add another subscriber to a connection already established. The operators can connect together as many as ten teletypewriters in each city to which the call passes.

The permissible speed of teletypewriter transmission is sixty words of six letters each, per minute. The communication path permits transmission in either direction alternately, just as in a telephone call. A receiving subscriber who wishes to transmit can interrupt by pressing his break key, which halts the recording of the outgoing message on the sender's teletypewriter. This serves notice on the sending subscriber to cease typing, and also prepares his teletypewriter to receive the incoming message.

The Teletypewriter Switchboard No. 1 has a capacity for 3,600 subscriber lines in the upper part of the jack field and 840 toll lines in the lower part. In each operator's position are eighteen cord circuits. The originating operator times each call by a one-tenth minute electric clock and fills out a charge ticket.

Known as teletypewriter exchange service, the new facilities have come into rapidly increasing use since their inauguration. For the many types of communication which must pass rapidly and accurately, which can proceed even in the absence of the called party, and of which records must be retained at both ends, the service should prove invaluable.



How a permalloy rod responds to the earth's magnetic field is a demonstration often made by Mr. Grace. Proper orientation of the rod determines whether it will pick up a thin sheet of permalloy or let it fall. Mr. Grace has recently addressed enthusiastic audiences in Chicago, Urbana and Springfield, Illinois



Coal for Transmitters

By J. R. FISHER

Chemical Research

THE relationship between a telephone and a prehistoric tree is not as remote as one might think. A logical journey can be mapped directly back from telephone to tree—a journey on which the main stopping-places are carbon and coal. It is generally known that the operation of the ordinary telephone transmitter depends upon variations in resistance at carbon contacts, and that the manner of preparing the carbon granules affects their usefulness. But with the strange way in which these granules are manufactured most people are not fully familiar.

This way is in sharp contrast with the way of manufacturing most telephonic equipment. In discussing the preparation of copper wire, for example, it would be academically thorough to treat of the natural processes by which copper ores were formed and the individual differences which the ores displayed, for smelting destroys these individual differences, ordinarily producing a uniform metal in which no trace of different origins remains. But in producing carbon for telephone transmitters from coal, there is no process analogous to copper-smelting; individual differences in the

coal profoundly affect the product. Thus the ultimate origins of transmitter carbon cannot be overlooked: its manufacture must be regarded as a continuous process requiring many hundred thousand years, in which Nature performs the first steps out of reach of human control.

Looked at in this light, coal is not the raw material from which transmitter carbon is manufactured but an intermediate stage in a manufacturing process for which the raw material was vegetable matter prehistorically grown, withered, fallen, and matted in layers upon the ground. Upheavals of continents submerged these layers beneath seas which deposited sand and silt upon them. Removed from the sea by new upheavals, the sand and silt hardened into sandstone pressing upon the vegetable debris. This pressure and the resulting temperature together gradually formed the vegetable matter into coal which further upheavals brought to light.

Carried out in the casual way characteristic of Nature, these manufacturing steps produced a material extremely varied in properties. Telephone engineers must take where they can find them the special properties desired in coal for microphone carbon, and learn enough about Nature's

manufacturing methods to predict where material with these properties can be had.

Three properties are particularly desired in coal for telephone use:

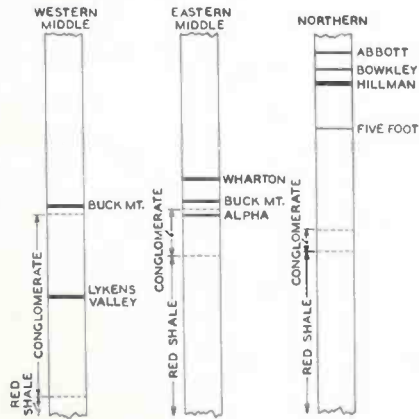

Fig. 2—Approximate columnar sections through some Pennsylvania coal fields, showing some of the anthracite beds whose coal has been tested for transmitter purposes

hardness, cubical fracture, and freedom from porosity. Unless the ultimate granules are hard, abrasion in use will affect their surfaces, changing the resistance and reducing the sensitivity of the transmitter. If they are flat, it is difficult to sift them to a uniform size. Finally unless they

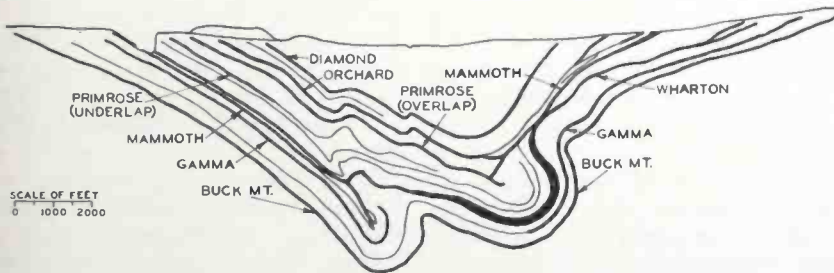

Fig. 1—Section through the eastern-middle coal field of Pennsylvania, showing some of the anthracite beds. The Bell System's coal comes from the lowest, the Buck Mountain, vein

are relatively free from pores, they will absorb and discharge gases during cycles of heating and cooling.

The desired properties are found only in the variety of coal known as

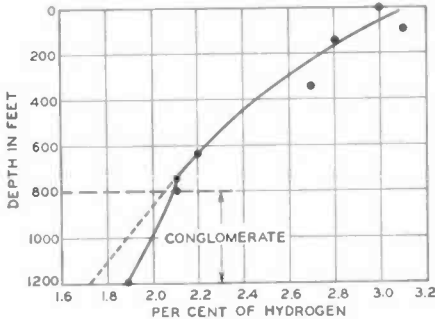

Fig. 3—The hydrogen content of anthracite decreases regularly with increase in its depth of burial (calculated for the above plot from an arbitrary zero) until the underlying conglomerate is reached

anthracite, and not always there. Anthracite is a hard, glossy form of coal; when burned, the heat it produces bears a high ratio to its weight. Since for all coal this heat is roughly proportional to the amount of fixed carbon the coal contains, the ratio of fixed carbon to volatile matter is called the “fuel ratio” and is used to give a quantitative ranking to coal. Anthracite has a fuel ratio not less than ten; bituminous, the softer coal, a ratio between three and six.

It would naturally be supposed that anthracite must have been subjected to higher pressures during its formation than bituminous; yet the two are found at the same levels, where the vertical pressures would be about the same. In contrast to bituminous, however, anthracite is found only in those parts of coal-bearing regions which show signs of much past geological disturbance, and this particular situ-

ation has led to the “thrust-pressure” theory of its production which reconciles the apparent contradiction.

According to this theory, coal forms “incompetent” beds, relatively plastic and tending to assume any imposed shape in contrast to the adjacent “competent” beds of sandstone and conglomerate, which cannot change shape appreciably. When sufficiently violent geological disturbances occur, the competent beds move and fracture and the incompetent beds adjust their shapes to these movements. The shifting of rock over rock can place enormous pressures on the coal: for example, by assuming a configuration in which a layer of rock acts as a lever with large mechanical advantage, to develop a local pressure which is ultimately communicated through the entire bulk of the relatively plastic coal. Thus in a geologically disturbed area coal may be subjected to far higher pressure than at the same levels in an undisturbed region.

It is noteworthy that even in areas of intense folding anthracite is not found where the underlying rocks and

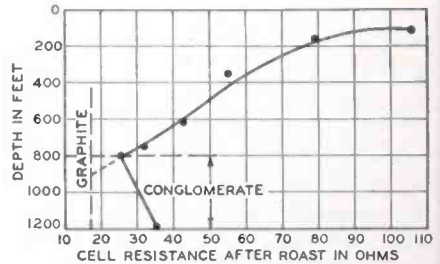

Fig. 4—Even after coal has been ground and roasted for use in transmitters, greater depths of the original burial of the raw coal are still reflected in decreased resistance in the transmitters (measured for the above plot at 1.5 volts). The cell resistance of graphite is a lower limiting value for carbon

the coal itself are not fractured. It is therefore supposed that even high temperatures and pressures will leave coal soft unless provision is ultimately made by fracture for the escape of volatile products. On the other hand, if fracture occurs too early in the coal's history, insufficient pressure may be developed. Thus there appears to be an optimum time, relative to the pressures exerted, for fracture to occur.

The coal fields of Pennsylvania (Figures 1 and 2) admirably illustrate the contrast between the conditions under which anthracite and bituminous are produced. The best anthracite is found among the Appalachian mountains in the eastern part of the state, markedly more complicated in geologic structure than the bituminous field farther west. Probably the anthracite region suffered an unusual amount of lateral compression when the mountains were developed, subjecting even the small undisturbed areas in the region to intense sidewise thrust-pressures. The anthracite is moreover far more fractured than the bituminous. It is from the middle of this region, along the main limb of the Appalachian mountains, that the Bell System takes all the coal for its transmitters.

In any series of coal seams in one region, the pressures might be expected to increase with depth. Granted adequate release of volatile constituents, this results in an increase of the fuel ratio with depth, a relation known as the Law of Hill. This law has proved of value in the selection of transmitter carbon: the lowest coal beds invariably produce the best carbons. For telephone purposes the hydrogen content of anthracite, varying roughly in inverse proportion to the fuel ratio, is a better rating than that

ratio (Figure 3). That depth of burial has a direct effect on electrical characteristics is shown in Figure 4. From the relation thus indicated between hydrogen content and electrical characteristics (Figure 5), it has been concluded that no coal with a hydrogen content greater than 2.2 per cent can be used.

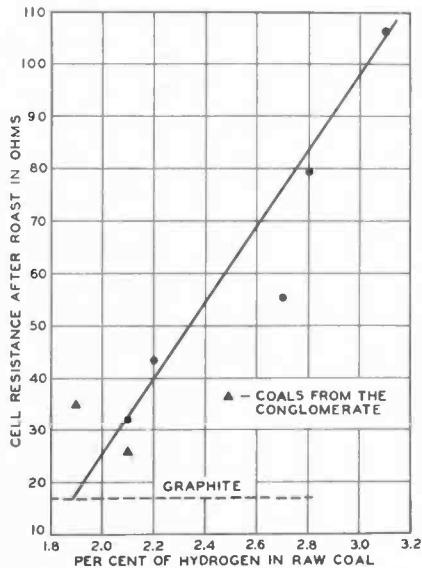

Fig. 5.—From the data of Figures 3 and 4 a useful relation between hydrogen content of raw coal and cell resistance of finished carbon can be obtained

Although hydrogen content has been the most valuable guide in the selection of coal, this chemical index is not an all-sufficient criterion. Close examination of almost any piece of anthracite discloses layers of three physically different constituents: "anthraxylon," deep black, very compact, and of bright luster; "atritus," grayish black, less compact, and duller; and "fusain," black, porous, and dull. For transmitter carbon anthraxylon is much the most suitable. This constitu-

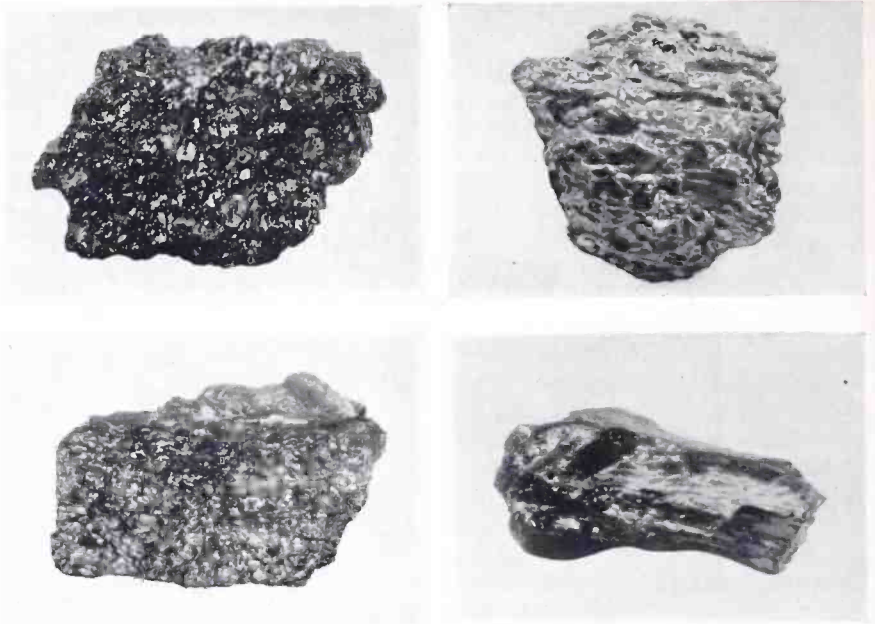
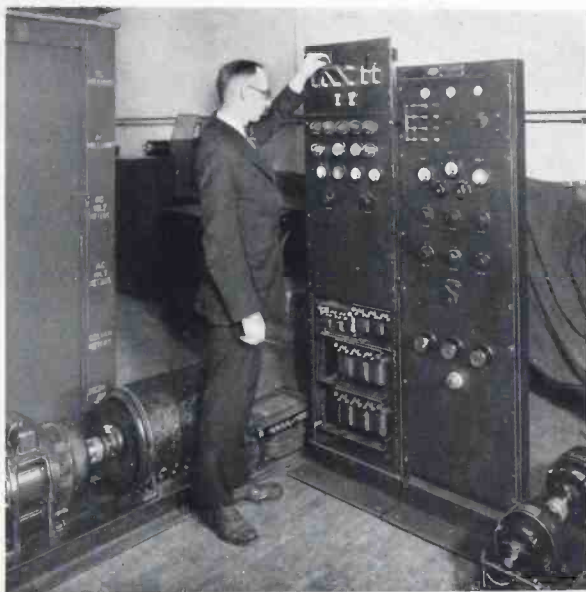

Fig. 6—Of the four types of grain which anthracite displays—short, fairly short, fine, and long—only the first three are suitable for transmitter carbon

ent in turn is found to have four different types of grain—short, fairly short, fine, and long—of which only the first three types lead to the “blocky” fracture desired in coal for transmitter carbon (Figure 6). Recalling this fracture, the miner terms such coal “bird’s-eye coal,” because its freshly broken surfaces show small rounded eyelike forms.

As long ago as 1918 the comparative rarity of suitable coal was realized, and to ensure a standard carbon a large quantity of anthracite, mined in the Upper Lehigh Basin, was stored at Hawthorne. By 1927 the need for

restocking coal became imminent and the exhaustion of the earlier mine made it necessary to search for another source. After study of many coals, a mine at Drifton Colliery was selected; the current output of carbon is manufactured from this material. Meanwhile the study of coals from other sources continues. Still more fundamental studies, of the physical chemistry of carbon, are determining why one coal is good and another is not, and are laying the foundation for producing artificially a material from which satisfactory transmitter carbon can be made.



An Adjustable Frequency Generator for the Voice Range

By J. R. POWER

Special Products Development

FOR several years the American Telephone and Telegraph Company and the National Electric Light Association through a Joint Subcommittee on Development and Research have been jointly studying interference between power and communication circuits and methods for avoiding it by coordination of their systems. One of the important aspects of this problem is the induction of disturbances in the telephone circuits by higher harmonics of nearby power circuits. In the course of these studies it became necessary to obtain an easily adjusted source of power capable of producing the harmonics of power line frequencies, that fall

within the voice range. A three-phase generator was needed capable of delivering as much as 100 volts-amperes per phase at any frequency between 200 and 3200 cycles per second. Additional requirements were that the frequency should remain constant at any set value within limits of ± 0.1 per cent, and that each of the three phases be independently controlled so that various unbalanced conditions could be simulated.

Such a wide range of frequency and such precise frequency regulation precluded the possibility of using any commercial machine now on the market. As a result the Laboratories was asked to develop such a power

source and furnish one model. The apparatus designed consists of two units: an adjustable-frequency motor-generator set and a vacuum tube control circuit. The assembled apparatus is shown at the head of this article.

Frequency is proportional to speed in a generator, and to secure the sixteen-to-one frequency range in a single generator would have required a range of speed difficult to obtain in a motor. This difficulty was overcome by building four generating elements, all mounted on the same shaft, with frequencies increasing in geometric ratio. Thus one generating element was wound for a minimum frequency of 200, the next for 400, the next for 800, and the last for 1600. With this arrangement and with a motor with a two-to-one speed range, any frequency from 200 to 3200 could be obtained.

Structural features of the generator are shown in Figure 1. The units are of the inductor alternator type. The principle of operation is indicated by the partial cross-section

of Figure 2. The field flux is generated by the large windings on the salient poles, and in the inductor alternator the armature conductors are in the form of coils wound on teeth in the face of the field poles. The rotor, which carries no windings, also has teeth but they have twice the pitch of those on the field poles. In the position shown on the sketch, flux is flowing through teeth a, c and e of the pole and teeth A, B and C of the rotor. As the rotor turns, however, and tooth A comes under b, the flux will shift from tooth a to tooth b and in doing so will cut the armature conductors and generate an electromotive force. Adjustable condensers are placed in the leads from the generator to form a tuned circuit so as to neutralize the high impedance of the winding.

The number of teeth required on the rotor depends on the frequency to be generated so that it differs for each of the four generators. There are twice as many teeth on the rotor of the 400-cycle generator as on that of the 200-cycle generator, etc. Each

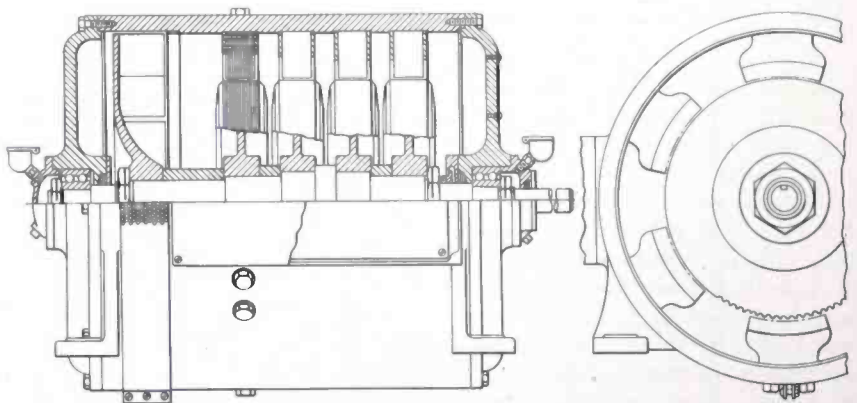

Fig. 1—The adjustable frequency generator consists of four generators mounted on a single shaft

generator has six poles—one pair being used for each of the three phases. The field coils for each phase are connected in series for all four alternators and for each phase there is a rheostat so that each phase may be controlled independently. Since only one of the alternators is used at a time this method is satisfactory and permits a minimum of equipment. Direct-current excitation is obtained from a small separate motor-generator set.

The drive for the generator is a standard adjustable speed repulsion motor with the addition of a small inductor alternator, used for speed control, built in one end. This alternator is of a design similar to that of the main generators except that it has a much smaller output and is only single phase. Since the motor and main generator are directly coupled together the frequency of the pilot alternator is a measure of that of the main generator. The speed of the motor is controlled by a three-legged reactor similar to those already described in the RECORD* for controlling the speed of the motors driving sound picture recorders. Windings on the two outer legs of the reactor are connected in series with the motor. The drop across these windings is increased, and thus the voltage across the motor—and the motor speed—is decreased, by decreasing the magnetic saturation of the reactor by a reduction of the current flowing

through the winding on the middle leg.

A simplified schematic of the circuit with which the speed is controlled is given in Figure 3. The output of the pilot generator on the motor is connected to a tuned circuit consisting of an inductance and an adjustable capacitance. This circuit is tuned to

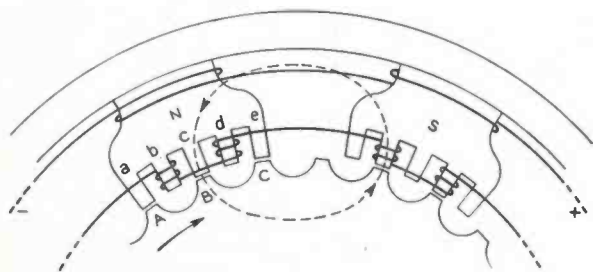

Fig. 2—Generator action in an inductor alternator is produced by changing the path of the magnetic flux by a set of rotating teeth

a frequency slightly above that corresponding to the speed at which it is desired that the motor run. Just below resonance frequency the voltage across the tuned circuit increases rapidly with frequency. In series with a negative direct-current potential it forms the grid bias for the vacuum tube V_1 .

The relation between the direct and alternating current biases is such that at the desired speed only small pulses of current, corresponding to the upper parts of the positive halves of the waves from the pilot generator, flow in the plate circuit of V_1 . If the motor increases in speed, however, the voltage across the tuned circuit increases rapidly and causes more current to flow in the output circuit of V_1 . This output circuit is so coupled to the grid of another tube V_2 that the output of V_2 decreases as

* BELL LABORATORIES RECORD, November, 1928, p. 101.

that of V_1 increases. The output of V_2 supplies current for the middle leg of the speed-regulating reactor and thus acts to control the speed of the driving motor.

This arrangement furnishes a very sensitive control which rapidly offsets

3) is incorporated in the actual control circuit. This compensation is obtained by using part of the voltage drop across the middle leg of the reactor as an additional bias for the detector tube V_1 . The actual circuit

also differs from that shown in employing vacuum-tube rectifiers for furnishing the various plate and biasing voltages, in using four vacuum tubes in a parallel push-pull arrangement in place of the amplifier tube V_2 on the sketch, and in other details.

The complete multi-frequency power unit for inductive coordination studies thus includes a main motor-generator unit, which is about two feet high and weighs 500 lbs., a small motor-generator

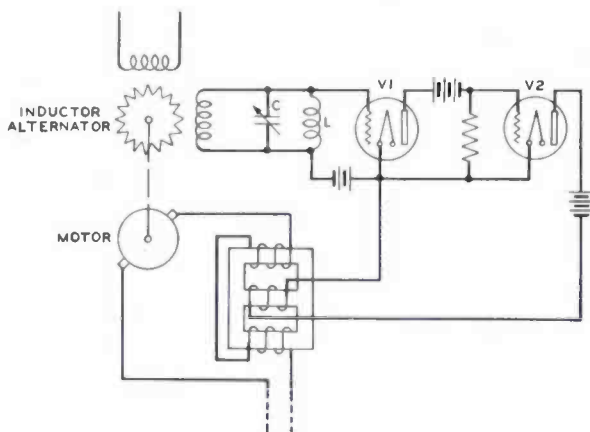

Fig. 3—Simplified schematic diagram of circuit controlling speed of inductor alternator

any change in speed of the motor. The circuit shown, however, would require a slight change in motor speed in order to produce the required change of current in the reactor. To avoid this, and to return the motor to the desired speed after each tendency to change, a compensating circuit (not shown in Figure

for supplying excitation for the main generators, a three-legged reactor, and two panels mounting the control equipment. Any frequency from 200 to 3200 may be obtained and held to within a tenth of one per cent. The equipment has proven very satisfactory in use and has greatly facilitated the study of inductive effects.

Hydrogenized Iron of High Permeability

By P. P. CIOFFI
Special Research

BECAUSE of their very extensive use in communication systems, magnetic materials are of fundamental importance to the Bell System. So great is the Laboratories' interest in the field that even in the early stages of the development of permalloy, when it seemed that the apex of desirable magnetic characteristics had been reached, a new program of investigation was inaugurated to determine the basic factors controlling the magnetic properties of iron. Certain of the results of this study have already been recorded. Of particular importance were the experiments with single crystals of iron.* Very high permeability was obtained, but the significant fact was that single crystals grown by high temperature heat treatment in hydrogen had higher permeability than those produced at lower temperatures in vacuum by Dr. D. D. Foster of these Laboratories, or than those grown in hydrogen by other experimenters elsewhere. The secret of the high permeability thus seemed to be in something other than the

development of a single crystal.

One of the methods of growing single crystals developed in the Laboratories consists in passing a zone of heat along a wire of small diameter in an atmosphere of hydrogen. At 910° C. the crystal structure of iron changes, and the essential feature of the method is to cool the wire from a temperature above this critical point to one below it over a very short section of wire. In this narrow region of cooling, a small alpha crystal on the cool side grows by feeding on the atoms undergoing rearrangement. To

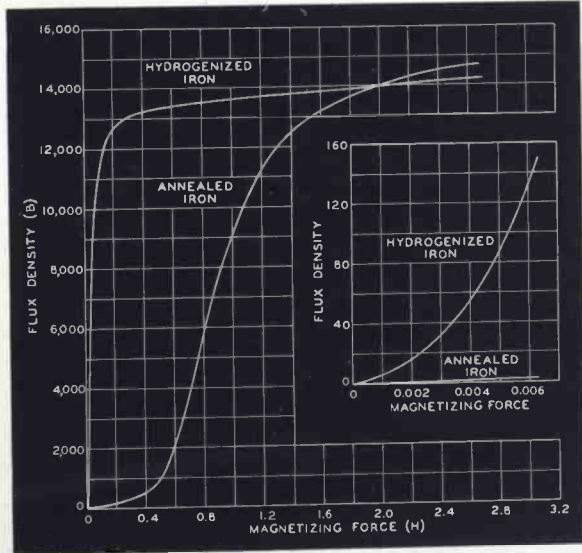

Fig. 1—Magnetization curves for ordinary annealed and for hydrogenized iron show the much greater relative magnetic softness of the new material

* BELL LABORATORIES RECORD, June, 1927, p. 343.

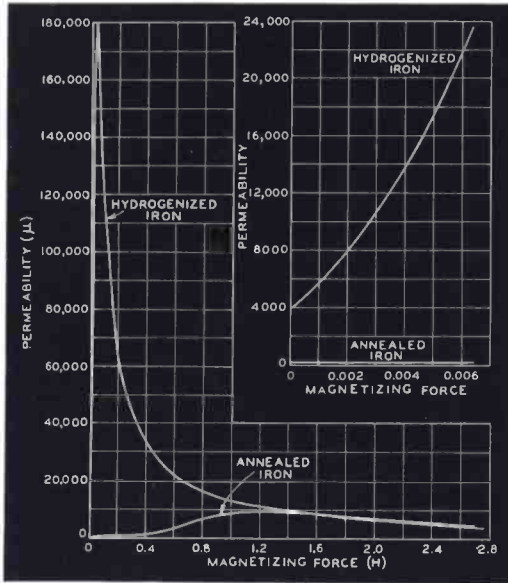

Fig. 2—Permeability of hydrogenized iron rises to very high values while that of iron has scarcely started to rise

obtain satisfactory results, the hot zone had to be at a temperature of nearly 1500° C.

When it was discovered that the single crystals grown in this manner had magnetic qualities superior to those of single crystals grown under other conditions, an investigation was undertaken to discover the cause of this difference in result. From these studies it was found that the better magnetic properties were dependent not upon crystal size but upon the high temperature heat treatment in hydrogen. Crystal size proved to be of secondary importance. As a result methods have been developed for producing iron with magnetic characteristics, which, regardless of the grain size of the crystals, in several respects are superior even to those of permalloy. An announcement of the discovery was made in a letter to the

editor of Nature, which was published early in August of 1930. The essential features of the process for iron are: heat treatment in hydrogen at a temperature between 1400° and 1500° C. for approximately 18 hours, and a subsequent anneal at a temperature below 910° C.—the point where the crystal structure changes. The resulting product is known as hydrogenized iron.

Very early experiments with wires of small diameters indicated that the essential factors were the high temperature heat treatment in hydrogen followed by slow cooling. Rapid cooling over the entire range did not produce the desired results. Extensive experimental work, however,

revealed that the cooling could be rapid over all but a narrow temperature range from 910° to 890° C. This is the region where the crystal structure changes from the gamma to the alpha phase, which suggested that the slow cooling over this transition was necessary to relieve the lattice strains introduced by the crystal transformation. It was therefore concluded, and subsequently demonstrated experimentally, that the cooling could be as rapid as desired over the entire range provided the metal was subsequently annealed at some temperature below the alpha-gamma transformation point. It was later found that even the severe overstrains produced by "hard-working" could be removed by such an anneal—a fact of considerable importance, since it allows the anneal to be deferred until the metal has been formed into its final shape.

Curves showing the relationship between flux density and magnetizing force for both ordinary annealed iron and hydrogenized iron are shown in Figure 1. Of particular importance for much telephone apparatus is the relationship at very small magnetizing forces, shown by the inset of the same illustration. The ratio of flux density to magnetizing force, called permeability, is one of the three most important characteristics of magnetic materials, and in all of them hydrogenized iron proves superior to ordinary iron.

Permeabilities of the same two specimens are shown in Figure 2. From these it will be observed that the maximum permeability for hydrogenized iron is far higher than for ordinary annealed iron. The actual figures are about 180,000 and 10,000, a ratio of 18 to 1. These maximum points, however, occur at different values of magnetizing force for the two materials. For the same values of magnetizing force, the ratio of the permeabilities may be even greater. With a value of 0.04 gauss, for example, the permeability of hydrogenized iron is more than 500 times as great as

that of ordinary iron. Permeability at zero magnetizing force, known as the initial permeability, is twenty times greater for hydrogenized iron than for ordinary iron for the sample shown, and in some specimens has been found to be as much as fifty times greater.

When the magnetic flux in a material varies cyclically, the curve of flux density does not follow the same path for increasing and decreasing field intensities. Hysteresis loops are formed as shown in Figure 3, and the area of these loops is proportional to the work done in carrying the material through the magnetic cycle. Areas of the loops for hydrogenized iron and annealed iron differ greatly as shown in the illustration. The actual hysteresis loss for hydrogenized iron at the flux density shown, less than 200 ergs per cubic centimeter per cycle, is only 1/16 that of ordinary iron. A comparison of the hysteresis of hydrogenized iron with permalloy is shown on Figure 4. These curves are for lower values of flux density because permalloy saturates at a much lower value of flux density than does either ordinary or hydrogenized iron. The hysteresis loss

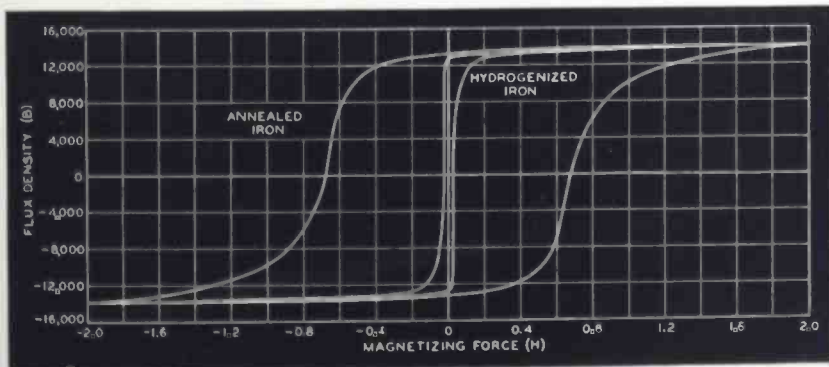

Fig. 3—Hysteresis losses of hydrogenized iron and regular iron present a striking contrast

of hydrogenized iron is only $1/3$ that of permalloy over the range shown.

The third important magnetic characteristic is coercive force. Its measure is the magnetizing force required to reduce the flux in the specimen to zero and in most cases it is desirable to have this force as small as possible.

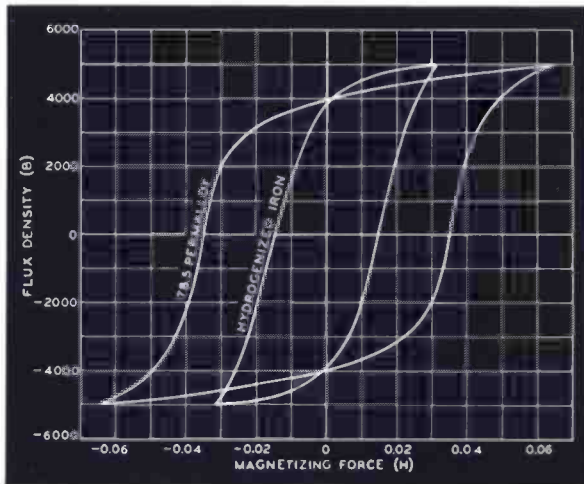

Fig. 4—Hysteresis of hydrogenized iron proves to be even better than permalloy

On the curves of Figures 3 and 4, it is the distance along the horizontal axis from the axis of ordinates to the point where either side of the hysteresis loop crosses the axis of abscissas. Its value, like that of hysteresis, also depends upon the maximum flux originally in the sample and so is different for the two illustrations, but the values for the two metals of each figure are comparable. From Figure 3 the coercive force for hydrogenized iron at a flux density of 14,000, some 0.025 gauss, is only about $1/27$ of that of ordinary iron, and from Figure 4, at a flux density of 5,000, it is only about half that of permalloy.

Not only can hydrogenized iron be produced with magnetic properties far superior to those of ordinary iron, but the values obtainable are consistently reproducible. With slight modifications the high temperature treatment will also give large improvements in the properties of iron alloys. An initial permeability of 35,000, the highest value ever reported in any material, has been obtained in permalloy containing 4% molybdenum. The maximum permeability obtained with this specimen is 140,000.

One of the interesting properties of hydrogenized iron is its extreme mechanical softness. It is almost as soft as annealed copper. Magnetic and mechanical softness have been known to be closely associated for a long time so that with the high degree of mag-

netic softness obtained in hydrogenized iron, it is not entirely surprising to find a high degree of mechanical softness accompanying it. During the early experiments unusually high permeabilities were occasionally obtained, and it was suspected that the results were due to some impurity. Investigation revealed that the large increase in permeability obtained in these cases was due to the presence of water vapor in the hydrogen. Advantage was immediately taken of this, and the high permeabilities now reported are secured by incorporating larger amounts of water vapor in the hydrogen by bubbling

through water at room temperature.

It is not yet known in what manner the high temperature hydrogen treatment produces the remarkable results secured. It is known, however, that improvements in magnetic characteristics may be obtained by purification, and chemical analyses show that the high temperature hydrogen treatment purifies iron of harmful impurities. Further evidences of this are large grain growth and mechanical softness. Carbon is one of the most harmful impurities known. As little as one atom of carbon per 2,000 atoms of iron, which is ordinarily found in commercial magnetic iron, is probably sufficient—together with other impurities—to account for its low permeability. The high temperature hydrogen heat treatment reduces the carbon to an amount undetectable by the usual methods of chemical analysis,

and it is reasonable, therefore, to believe that the improvement in magnetic characteristics is due to purification. During the treatment, however, an absorption of hydrogen takes place amounting to about one atom per 1,000 atoms of iron. With what is known today regarding the large effects on the physical properties of metals of very small amounts of impurities such as carbon, another possible interpretation is that the absorbed hydrogen itself is essential for the good characteristics of hydrogenized iron. Whether or not absorbed hydrogen plays any important part in these results and what the function of the water vapor is, remain at present uncertain. Investigation is being continued and a technique is under development for determining the relative importance of purification and absorbed hydrogen.



Mortar Bandage Conduit Joints

By J. M. HARDESTY
Outside Plant Development

NEARLY fifty years ago the demand for telephone service had already grown to such an extent that it became necessary to find ways of putting communication wires underground, particularly in certain city locations. For most of the early underground installations, cables were constructed by drawing insulated wires through lead pipes, which were then filled with paraffin. These cables were laid in the ground, usually in a wooden trough, and covered over with pitch or asphalt.

By 1883 it had come to be realized that a system of ducts was needed for housing cables so that any cable which, because of defect or for other reason, needed to be withdrawn could be readily recovered. For the first

of these installations the conduit employed was iron pipe, with an outside diameter of approximately three inches. It was encased in concrete and terminated in waterproofed brick manholes. From 1884 to 1890 the duct material most used for cable "drawing-in" subways was either iron pipe or wooden conduit.

About this time vitrified clay or glazed tile was also tried for cable conduit. The first designs were not very satisfactory, but within two or three years the manufacturers of this material learned how to make hollow clay ware which could be fabricated with one, two, or several ducts in the same piece. This type of conduit was not expensive to install, and also when put in the ground it was more perma-

ment than iron pipe, which would rust, or wood conduit, which was apt to decay. Consequently, in the telephone field in the United States, vitrified clay conduit has been for many years the most used type of underground conduit for main line construction. The various units in common use in the telephone plant today are shown in Figure 1.

In installing clay conduit the sections laid in the trench are doweled together with short steel pins to align the ducts. To make the joints reasonably tight, it has been the practice to trowel cement mortar over each joint, first applying a strip of cheesecloth to keep the mortar from entering the ducts. To seal the joint at the bottom, a pat of mortar is first laid in the bottom of the trench and into this the tile is bedded.

When these troweled mortar joints are carefully made, they are usually sufficiently tight so that even after a number of years not enough silt enters the ducts through the joints to prevent pulling cables in or out. It is often difficult, however, to make sure of a good job, particularly underneath the tiles, or between two tiles laid closely side by side where the joint cannot be reached with a trowel. Often an infiltration of silt will not cause trouble until several years after the line has been installed, but when the trouble does appear, it is paid for dearly in the extra cost of rodding and cleaning the ducts, or in excavating to clear obstructions.

Many types of con-

duit joints have been tried to discover a method of joining which would be more effective in excluding silt and still be as practical as the troweled mortar joint. These have included plastered asphalt joint coverings, melted asphalt, or asphalt emulsions applied on cloth strips and wrapped around the joint, mortar joint coverings confined close to the joint by thin sheet metal forms, and joints made with conduit having special shaped ends (as bell and spigot ends) joined with cement mortar, or with soft gaskets. Experience and study of all of the different methods have led to the conclusion that, for general application in the Bell System, a method is desirable which is still better than these from the standpoints of strength, silt tightness, and ease of application.

Within the past year a new method for joining clay conduit has been developed which promises to be both practical to use and effective in excluding silt. This is called the "Mortar Bandage Conduit Joint." As the name implies, the new joint covering is a bandage or poultice which is wrapped around the joint. This ban-

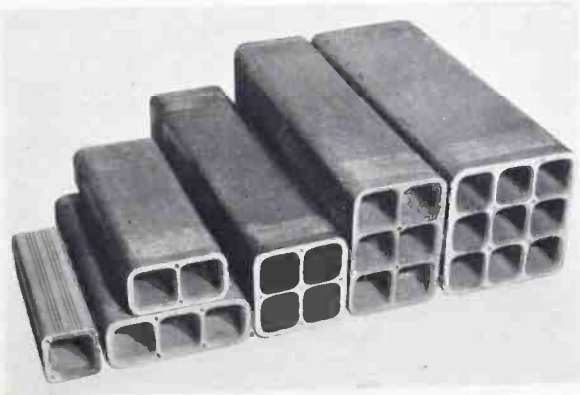

Fig. 1—Types of vitrified clay conduit used in the telephone plant

dage is from five to seven inches wide, with a cheesecloth envelope filled with plastic cement mortar which hardens after the joint has been wrapped.

Schemes similar to the mortar bandage joint have been tried before, but have not proved satisfactory. As with many inventions which seem simple in the finished state, there were several problems of technique and materials which had to be solved before a satisfactory bandage could be made. One of these was to design a bandage easy to handle and apply uniformly and yet thick enough to provide a strong joint. A bandage constructed by merely encasing a half-inch thick ribbon of mortar in a cheesecloth covering did not handle satisfactorily because the mortar filling slumps or sags down in the casing. To avoid this the bandage was built up first of a quarter-inch layer of mortar, then a strip of reinforcing cheesecloth, and finally a second quarter-inch layer of mortar.

The design of the bandage and the kind of mortar used had to be adjusted to insure a firm bond to the surface of a vitrified clay conduit. This was accomplished by using cheesecloth with meshes large enough to allow the cement mortar paste to flood through when the bandage was pressed against the tile, and by employing a mortar with the desired amount of cement paste. The mortar found most effective to use was a

1:1½ mixture of special portland cement and sand, plus a small amount of diatomaceous earth, a very fine powder which, holding a large amount of water, makes the mortar plastic and keeps it so for a considerable time. When the bandage is pressed against the surface of the conduit, this water is available for flooding cement mortar paste through the cheesecloth, if it is used within half an hour after making.

The bandage had to be designed so that it was not messy to handle and so that the water would remain inside, available for hardening the mortar after the joint was wrapped. This was accomplished by putting a piece of stiff waterproofed paper in the bandage so as to be on the outside of the bandage and just under the outer cheesecloth covering when the joint is wrapped. The construction of the bandage is shown in Figure 2.

The paper is shown being put in place in the photograph at the head of this article. It keeps the cement mortar paste from flooding through to the outside of the bandage and at the same time allows it to flood freely through to the tile surface. To keep it compressed firmly against the conduit until the cement mortar hardens, the wrapped bandage is tied firmly in position by cotton tapes.

A method has been worked out whereby bandages in condition, ready for use, can be made up quickly and easily in the field. A portable bench is provided as shown in the photograph at the head of this article and at it two men can make bandages at the rate of about one per minute.

A strip of cheesecloth three times as wide as the steel tray is laid lengthwise down the tray so that the edges of the cloth hang over the sides and

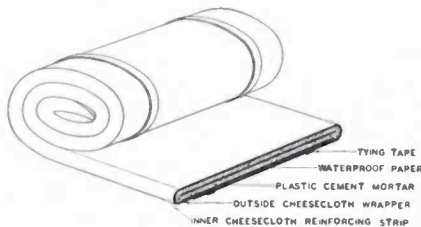

Fig. 2—Cross-section of mortar bandage showing interior construction

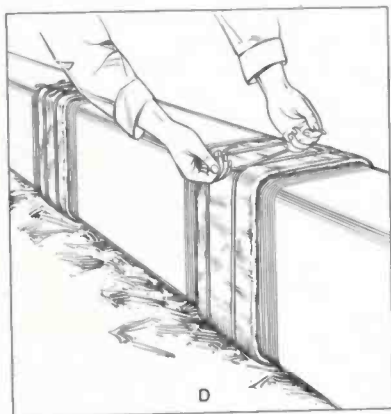
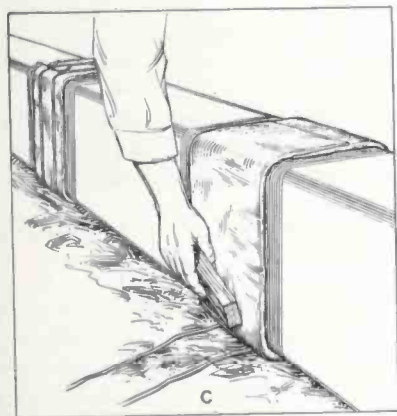
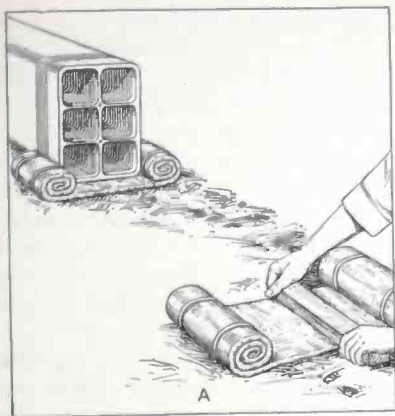

Fig. 3—A graphic description of the method of applying the bandage

on it is troweled a quarter of an inch of mortar. On this mortar is placed the reinforcing strip of cheesecloth and on top of it another quarter inch of mortar is troweled. The water-proof paper is then laid on and the edges of the outer cheesecloth wrapper are folded over it. In the meantime the tying tapes have been laid on the raised shelf at the side of the steel tray, and the bandage is now tipped over on top of them. The bandage is then rolled up from both ends together with the tapes and is ready

to be applied to the conduit. The various steps in the application are shown in Figure 3. The bandage is partially unrolled and placed in the bottom of the trench where the conduit joint will lie. To cause the cement mortar paste to flood through and make a good joint, the inside is patted or smoothed as shown at "A" of the illustration. After it has been wrapped around the joint, the outside is stroked for the same purpose as shown at C. The final step is firmly tying the wrapping tapes to hold the



Fig. 4—Taking a motion picture illustrating the making and applying of mortar bandage joints to serve as instructions to the field

bandage tight to the conduit until a firm union has been formed by the hardening of the cement.

Clay conduit runs joined with mortar bandages are strong enough to be self-supporting over any reasonable length of span, such as might happen in case a cross trench is opened underneath it. In certain tests that have been made, a 6-foot unsupported span of two-duct conduit laid flat and containing three joints withstood a 1000-pound load. These high strengths that can be developed in mortar bandage joints are expected to make possible considerable savings in telephone plant work by reducing the number of occasions in which the concrete base or concrete top now commonly employed to maintain conduit alignment, are required.

Mortar bandage conduit joints are decidedly more effective in excluding silt and water from conduit runs than any other type of joint which has been investigated. At the Laboratories' Field Experiment Station at Chester, New Jersey, this has been tested several times in specially constructed "flooding trenches."

Another advantage of the new joints is that since the mortar is confined in a cheesecloth envelope it is not apt to be cracked or injured by slight motions of the conduit, such as those caused by the workmen stepping on the tiles. In fact, after the bandages are put on, the conduit can be shifted to align it in the trench without injury, provided this is done before the mortar has started to set. A feature of greater importance is that back-

filling on mortar bandaged joints can be done immediately after the joints are finished, rather than waiting for several hours as is required in the case of the troweled mortar joint.

Some 10,000 duct feet of conduit joined with mortar bandages have been installed at Chester by the Laboratories' engineers under field conditions not essentially different from those encountered in the telephone plant. This new joining method has also been used already by several Associated Companies on test jobs. The technique involved in making and using the bandages is easily acquired by the same workmen that are employed in making the ordinary troweled mortar joints, provided they learn how to start in the right way.

Printed instructions illustrated by still photographs have been circulated to the Associated Companies explain-

ing how to join conduit by the new method. Such written descriptions, however, have not proved to be altogether satisfactory in conveying an adequate idea of just how to handle bandages to make the job easy, of the most desirable consistency of mortar, or of just why it is important to make bandages with the particular form of construction shown in Figure 2.

To illustrate more vividly, therefore, certain of these important features of mortar bandage construction and use, a talking motion picture has been made by the Laboratories for circulation to the Associated Companies by the American Telephone and Telegraph Company. This is the first case of what might be called "Animated Handbook Instructions for the Construction of Outside Plant." Figure 4 shows the taking of this picture at Chester.



The Lapel Microphone

By W. C. JONES

Transmission Instruments Engineering

MANY speakers, unfamiliar with the use of the conventional stationary microphone, mar the public-address programs in which they take part by straying away from the instrument. To permit the speaker to move about more freely, a microphone has been developed which is worn on his clothing and moves with him. This microphone is an adaptation to public address use of the essential elements of a transmitter recently developed for operators. It is only about an inch in diameter and weighs about

one and one-half ounces. A thirty-foot length of flexible cord provides the connection to the amplifier of the public address system.

The diaphragm is made of thin aluminum, formed into a cone to provide sufficient stiffness to cause it to vibrate as a unit throughout the frequency range of interest. A number of impregnated paper rings, about four ten thousandths of an inch thick, support the edge of the diaphragm. The dimensions of the recess into which these rings fit are such that the rings separate slightly from one another. This not only provides a resilient support for the diaphragm but also adds a certain amount of damping which reduces the effect of resonance and improves the response characteristics.

Unlike the carbon microphones now in use in public address work, in which the diaphragm forms one of the electrodes, the diaphragm of the lapel microphone is insulated by a coating of phenol varnish from the granular carbon. Electrical connection to the carbon is made through two stationary cylindrical electrodes, insulated from each other by a ceramic barrier which also serves to define the current path through the carbon. In order to increase the life of the microphone and reduce the noise which results from moving it about, the space between the electrodes is filled practically full of carbon.

A rubber covering for the micro-



Fig. 1—H. L. Lundberg demonstrates how, when the lapel microphone is in use, the jack and plug are placed in the coat pocket

phone eliminates the disturbing noise which would otherwise result from rubbing against the speaker's clothing, or would be picked up through the clip which is provided for attaching it to the clothing. The clip is so arranged that the microphone can be attached to either the inside or outside of the breast-pocket of a coat, or to the lapel. The latter position is preferable, for it brings the micro-



Fig. 3—Associated with the lapel microphone, an input circuit attenuates the lower frequencies which the microphone picks up from the speaker's chest, and prevents clicks when the microphone is cut in or out of circuit

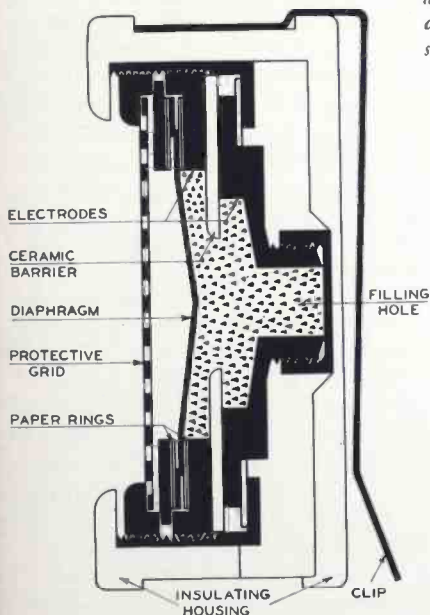

Fig. 2—The lapel microphone is of the granular carbon type, with an unstretched cone-shaped diaphragm of aluminum. The two electrodes are stationary and are electrically insulated from the diaphragm

phone closer to the speaker's lips and increases the intensity of the speech without adding to the interfering noise. In the case of a woman, the clip can be fastened to her dress with a pin.

The frequency response characteristics of the lapel microphone compare favorably with those of the stretched diaphragm type now in use. Owing to the smaller size of the lapel model, less sound field distortion is introduced. When worn on the speaker's clothing, however, the instrument picks up sound as the result of chest vibration in addition to that reaching it through the air. The part due to chest vibration is rich in low frequencies, and if unattenuated results in a "deep" unnatural quality of transmission. A special input circuit has therefore been provided for connecting the microphone to the public address amplifier. This circuit attenu-

ates the low frequencies sufficiently to correct for the effect of chest vibration. Provision is also made in this circuit for supplying direct current to the microphone, and suppressing clicks when it is switched in and out of circuit.

Complete equipment, consisting of the microphone, the flexible cord and the apparatus unit which contains the input circuit is shown in Figure 3. The unit shown is arranged for connecting only one microphone at a time and is provided with a lamp which lights when the microphone is connected in circuit and is ready for use. Another unit permits a number of microphones to be connected at one time, of which any one can be selected at will. A plug and jack are provided in the cord so that the microphone can be disconnected if desired. The plug contains a small condenser to prevent the cohering of the carbon granules which would otherwise occur were the plug withdrawn from the jack while the microphone is connected in circuit. When in use, the plug and jack are placed in the coat pocket. This prevents mechanical vibration from

being transmitted through the cord to the microphone and introducing noise.

Mr. S. P. Grace was the first to use this microphone. His audiences have marveled at the loudness and clearness with which his voice reached them, even in large auditoriums, and for the most part have been unaware that he was using a microphone. They have only realized its part when he called to their attention that he had concealed the microphone in his coat pocket, and the cord by passing it down his trouser leg. The portability of the instrument has enabled him to move about freely while demonstrating his apparatus, in a way which would otherwise have been quite impossible.

It is expected that the lapel microphone will find application in churches, convention halls, banquet rooms, lecture rooms, and the like. The instrument will be a boon to speakers who depend on gestures for effective delivery, who must turn to explain lantern slides or use a blackboard, or who find it difficult to put their personality into their message if their position is restricted.



Portable Balance Unit for A-C Precision Bridge

By S. J. ZAMMATARO

Telephone Apparatus Development

FROM the description* of the more important a-c precision bridges designed for laboratory use, it is evident that a substantial portion of the construction is alike in the various types. This portion, consisting principally of the ratio arms and the transformers for the detector and power source, may be considered as the balance unit. Completed by the special standards of impedance, it becomes a full-fledged impedance bridge.

A completely self-contained bridge is generally of greatest usefulness for a specific type of measurement. A balance unit by itself, however, offers considerable flexibility in use with sepa-

rate external standards where measurements of a miscellaneous character are required. For this purpose, therefore, there has been developed a special unit containing only the essential elements of the balance portion of a bridge. In the interest of economy and convenience the dimensions of the unit have been kept within $8 \times 8 \times 10\frac{1}{2}$ inches, while its weight has been limited to fifteen pounds. By careful design this small size and weight have been obtained without sacrifice of precision.

One of the important features of any bridge designed for alternating-current measurements is the shielding. Without shielding stray admittances would exist between various elements

* RECORD, December, 1929, p. 167.

of the bridge and between elements and ground. The operator would also contribute his share of stray admittances which would be doubly pernicious because their value would change with each new position the operator assumed. All these stray admittances would form a sort of secondary network through which would circulate a portion of the bridge current, thus upsetting the true balance. Some of these stray admittances are indicated by the dotted capacities of Figure 1a as they would exist in a balance unit. The general principles followed in the application of shielding have already

been discussed in the RECORD,* but their application to such a balance unit requires consideration of all the particular connections and uses involved.

The first step toward controlling the offending admittances is to surround each element with a shield. This substitutes a single admittance between unit and shield for the varying admittance which, without it, would exist between the unit and other units and ground. The next step is to establish a definite potential for the shields by connecting them to one or the other terminal of the shielded ele-

* RECORD, November, 1931, p. 88.

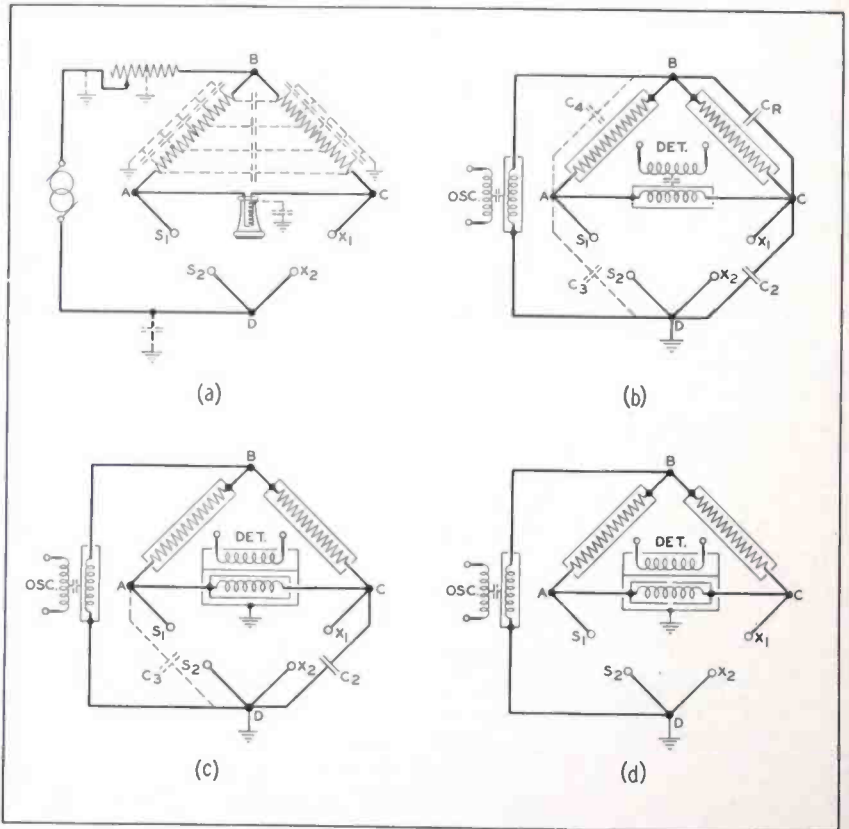

Fig. 1—Successive steps in studying the application of shielding to the balance unit

ments. That terminal is selected in each case, which results in the least unbalancing effect on the bridge network of the admittance of the shield. Because of the changeable positions and usually uncontrollable conditions of the power source and the detector, it is impractical to consider them as constituent elements of the bridge system. They are, therefore, coupled to the bridge network by suitable transformers, which can be treated as elements of the bridge, and suitably shielded. The balance unit so shielded is shown in Figure 1b.

For the moment it may be considered that the impedance to be measured will be grounded, as indicated by the ground at D. This eliminates the ground admittance of the shield of the power transformer and places the admittances of the shields of the ratio arms across the B-D diagonal, where they do not affect the balance of the bridge. The admittance of the detector shield, indicated by the dotted capacity C_3 across AD, may be compensated by an equal admittance, C_2 , connected across CD. Similarly the admittance between the shields of the ratio arms and the detector transformer, represented by the dotted capacity C_4 , falls across the ratio arm AB and can be balanced by an equal admittance, C/R , across the arm BC.

The arrangement of Figure 1b is not entirely satisfactory, however, because any changes of admittance in the detector affect the admittance between the shield of the bridge winding of the detector transformer and the unshielded winding, and hence are reflected in the admittance across AD. To remedy this condition a second

shield, connected to ground, is placed around the first shield of the bridge winding and extended to include the other winding of the transformer. With this arrangement, shown in Fig-

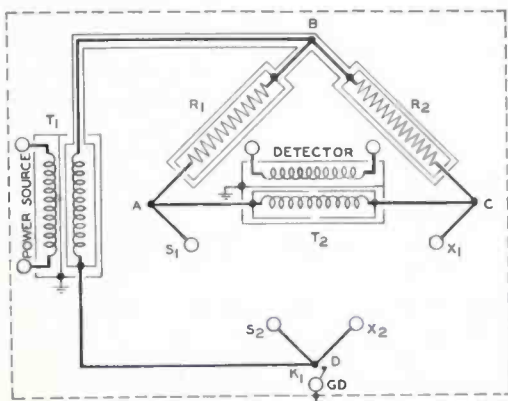

Fig. 2—Diagrammatic representation of the completely shielded balance unit

ure 1c, not only is the bridge network made free from detector disturbances, but the admittance which formerly existed between the inner shield of the detector transformer and the ratio arm shields is eliminated, and thus the compensating admittance C/R becomes unnecessary.

It is possible to eliminate the other compensating admittance, C_3 , also, by splitting the inner shield of the detector transformer winding and connecting the two halves to the two corners A and C. The admittances across AD and CD are now of about half the value they were previously and being of like character help to preserve the impedance arm balance over a wide frequency range. The detector transformer needs only a single shield since, with grounded measurements, any disturbances from the power source are reflected across the BD

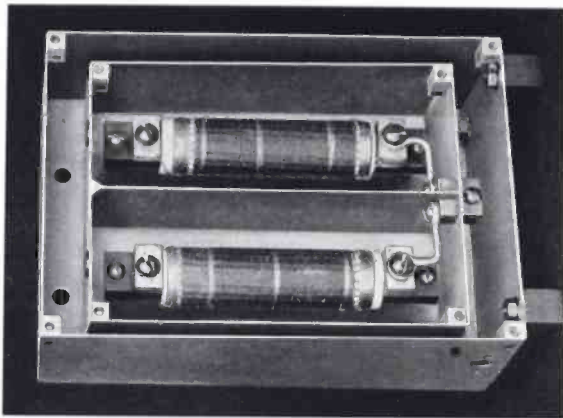

Fig. 3—Woven wire ratio arms enclosed in their double shield

diagonal and do not influence the bridge balance.

While such an arrangement, shown in Figure 1d, is adequate for grounded measurements, additional refinements are required when the test impedance is to be measured in the balanced-to-ground condition. With this arrangement the ground is removed from D and ground potential must be established at a point midway between the corners C and D. Removing the ground from D results in an admittance to ground from all four corners of the bridge, and considerably complicates the problem. If, however, the ground admittance from the B corner is eliminated, the only requirement will be that the ground admittance from D be equal to the sum of the ground admittances from A and C.

This may be accomplished by placing a second shield around the ratio arms and extending it to enclose all wiring at the potential of B. By connecting this shield to the D corner, the admittance from B falls across

BD where it is harmless and at the same time permits the simple balanced-to-ground relation to hold. With D ungrounded, however, it is necessary to double shield the power transformer to prevent disturbances in the power source from altering the admittance from D to ground. With the addition of an outer grounded shield around the whole assembly, as a further precaution against variable ground admittances the arrangement is satisfactory for both grounded

and balanced-to-ground measurements. The new balance unit is shielded in this manner, as shown in Figure 2, and a key is provided which will ground D for grounded measurements or leave it ungrounded for balanced-to-ground measurements.

The ratio arms have a resistance of 1,000 ohms to satisfy the requirement for maximum bridge sensitivity based on an average test impedance of 1,000 ohms. The resistance of each arm is made up of No. 38 double silk-insulated manganin wire woven into a fabric sheet approximately three inches square. This sheet is wrapped once around a hollow isolantite spool about an inch in diameter and three inches long and then thinly coated with superlax for protection. The size of the unit is ample to give a dissipation of $2\frac{1}{2}$ watts, which is sufficient for usual impedance measurements. By the use of the woven construction, inductance and distributed capacitance are reduced to a minimum so that an extremely low phase angle is obtained with practically constant resistance

over a wide frequency range. A set of the ratio arms assembled in their double shield is shown in Figure 3. They are matched to better than .005 per cent in resistance and to 0.1 $\mu\mu f$ in phase angle over a frequency range of from 100 to 100,000 cycles.

To reduce adequately stray electromagnetic fields, the transformers are designed with the primary and secondary windings equally distributed around a toroidal core of high permeability and the whole coil assembly is potted in a cast aluminum case. Surrounding the winding that connects to the bridge are two tinfoil shields insulated from each other by hard pressed-paper separators. The inner shield is in two equal sections which may be connected together for the power transformer, or individually connected to the opposite terminals of

the winding for the detector transformer.

The completely assembled balance unit, removed from the outer metal housing, is shown below. All shielding, including the pipes inclosing some of the wiring, is made of aluminum, and the whole assembly is mounted on an aluminum panel by means of hard-rubber supports of low loss. In the photograph at the head of this article the various terminals can be seen on the top of the completely housed unit. The key for the ground connection is near the front edge. The lightness and compactness of the unit makes it very convenient for use where precise tests of a miscellaneous kind are necessary. With it impedances may be compared to an accuracy of 0.1 per cent over the frequency range of 100 to 100,000 cycles.

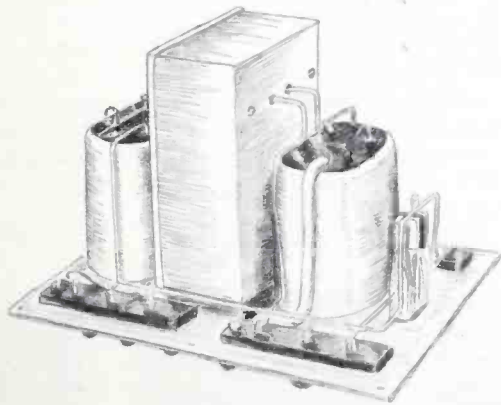



Contributors to this Issue

O. B. BLACKWELL, after graduation by M. I. T. in 1906, entered the American Telephone and Telegraph Company. Loading was then in its infancy, toll cables were short and good telephone transmission limited to about a thousand miles. He contributed to the development of the Boston-New York-Washington cable, to New York-Denver transmission, and to the important advances of transcontinental and transatlantic telephony which followed. In 1914 he became Transmission Protection Engineer and in 1919, with the formation of the D & R Department, Transmission Development Engineer.

AT THE completion of an engineering student training course at Hawthorne, W. C. Jones came to West Street in 1914 to assist in the development of telephone instruments. The World War interrupted studies which were being made of means for quantitatively determining the response of microphones and for improving their frequency characteristics. Until the Armistice, Mr. Jones was engaged in the development of submarine detection systems at the various experimental stations

established by the Navy. Since the War, Mr. Jones has been engaged in further telephone instrument studies at the Laboratories, and has had a part in developing improved telephone transmitters and receivers, the cone loud speaker, and recording, reproducing and loud-speaking equipment for sound pictures. In 1922 he took charge of a group working on transmission instruments involving the magnetic circuit, and three years ago he assumed responsibility for telephone instrument development.

BEFORE graduating from Cornell, S. J. Zammataro spent three summers on coil design with the Engineering Department of the Western Electric Company. After getting his E.E. degree in 1921, he joined the Technical Staff of what has since become Bell Telephone Laboratories and for four years was engaged in testing work in the Special Products Laboratory. He later became interested in alternating current bridge measurements and now is supervisor in charge of this field.

J. R. POWER received a B.S. degree in



O. B. Blackwell



W. G. Jones



S. J. Zammataro



J. R. Power



J. M. Hardesty



A. B. Kouwenhoven

Electrical Engineering from the Carnegie Institute of Technology in 1927. Entering the Apparatus Development Department of the Laboratories that same year, he became engaged in the development of special motors and generators with particular reference to voltage and speed regulation. The major portion of his work has been on problems connected with sound picture reproduction.

J. M. HARDESTY graduated from the University of Texas in 1923 with a B.S. degree in Civil Engineering. At the end of a two-year appointment as a Research Assistant in the Engineering Experiment Station at the University of Illinois, he received a M.S. degree in Civil Engineering. The following two years he spent in

the Graduate School of the same university on work leading to a Ph.D. degree in engineering. In the fall of 1927 he joined the Outside Plant Department of the Laboratories and since then his work has been chiefly connected with problems relating to materials and methods of construction used in underground conduit installations.

ARTHUR B. KOUWENHOVEN joined the Western Electric Company in March, 1929, as a member of the General Commercial Engineers' Department. Since that date he has been engaged in the preparation of literature describing Western Electric Products and at the present time, under J. C. Winslow, is supervisor of the group responsible for this work.



J. R. Fisher



G. A. Locke



P. P. Cioffi

J. R. FISHER joined the New York Telephone Company's Plant Department in 1921, where he worked on battery-feed problems for the switchboard group. Meanwhile pursuing chemical studies at Brooklyn Polytechnic, he received the B.S. degree in 1927. The following year he transferred to the Chemical Department of these Laboratories, undertaking the investigations into the physical chemistry of carbon, which he is still continuing. In 1930 Brooklyn Polytechnic awarded him the M.S. degree.

G. A. LOCKE entered the Bell System in 1908 by way of the New York Telephone Company. In 1914, he transferred to the Engineering Department of the Western Electric Company, where he engaged in the development of printing-telegraph apparatus. During the war he went to France as a member of the Signal Corps in a special unit dealing with printing and other telegraphic communication circuits. On returning to this country in 1919, he again became associated with the Laboratories, spending three years on printing-telegraph development in the Systems Department, and then transferred to the

Research Department, where he worked on apparatus for high-speed transatlantic telegraph cable. During this period he received both a B.S. and an E.E. degree from Cooper Union. In 1928 he joined the toll development group, where he has since been engaged in the design of telephone typewriter systems. As supervisor of the group developing telegraph switching methods, he was largely responsible for the new teletypewriter exchange.

P. P. CIOFFI entered the Research Department of the Laboratories in 1917, where he took part in vacuum tube development work. This subsequently involved a study of gases occluded by glass, the clean-up effect by carbon filaments, and the effect of gases on the thermionic emission from carbon filaments. During this time he was continuing his studies outside, and received a B.S. from Cooper Union in 1919 and an E.E. in 1923. He also studied engineering at the Brooklyn Polytechnic Institute, and physics at Columbia, from which university he received an A.M. in 1924. For the last ten years he has been engaged in studies of the properties of magnetic materials.

ANNOUNCING A NEW TELETYPEWRITER SERVICE



THE BELL SYSTEM offers to the public a new Teletypewriter Service. Any subscriber to this service may be connected, through the teletypewriter "central," to any other subscriber, whether he be around the corner or across the continent. Subscribers can type back and forth by wire, for short or long periods, just as they now hold conversations by telephone.

This important development for the business world parallels the other progress which is constantly being made in the telephone art.

Messages, inquiries, reports—typed in one office—are instantly and accurately reproduced on the other subscriber's teletypewriter. Typewritten copies made by both sending and receiving machines are available for permanent records. The principal feature of this new service, which distinguishes it from existing private line

teletypewriter service, is that any subscriber may ask for any other subscriber and be connected immediately.

Further information about this new development in nation-wide communication will be furnished gladly by your local Bell Telephone Business Office.

Teletypewriter Service provides two-way communication.

Speed of connection is as fast as telephone service.

A typewritten record, one or more copies, is produced simultaneously by both sending and receiving machines.

Material transmitted may be recorded on forms if desired.

Teletypewriters are like ordinary typewriters in appearance.

Teletypewriters can be operated by any one who can operate a typewriter.

You can use Teletypewriter Service any time you need it.

A most economical form of record communication.

AMERICAN TELEPHONE AND TELEGRAPH COMPANY

