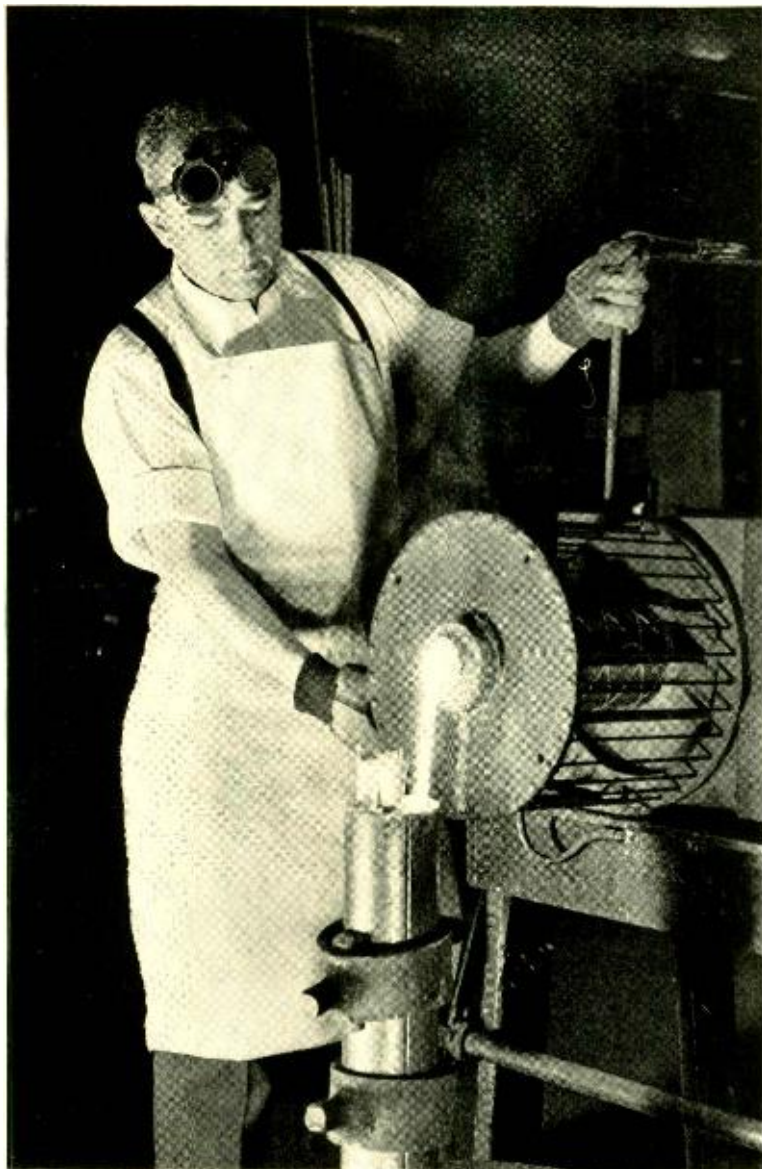


# BELL LABORATORIES RECORD



APRIL  
1938

VOLUME XVI  
NUMBER VIII

*Casting a magnetic alloy*



## Broad-Band Carrier System for Cables

By M. L. ALMQUIST  
*Toll Transmission Development*

**O**F the broad-band carrier systems, the type K for cables was the first to go into regular commercial service. Two complete systems have been installed in existing cables between Toledo and South Bend, a distance of 150 miles, and have been under test for a number of months. The tests included a period of operation during which the channels were used for commercial traffic with very satisfactory results. The system operates on 19-gauge non-loaded pairs, and provides twelve one-way channels per pair. Like the other broad-band systems, type K employs a four-wire circuit—different pairs being used for transmission in the two directions. The same frequencies, however, serve for both directions of transmission, so that shielding is essential between the oppositely-directed

transmission paths. In existing plant, this shielding will be obtained by employing different cables for the two directions of transmission. Where new cable is to be provided, the same arrangement may be used, or the pairs in a single cable may be divided into two groups separated from each other by an internal shield which would normally consist of several layers of copper and iron tape.

The twelve channels mentioned provide voice circuits with a useful frequency range of over 3000 cycles. Any of the channels may be used for voice-frequency carrier-telegraph systems and thus supply twelve (or more) telegraph channels in place of a single voice channel. In addition, arrangements are also to be made to allow a program channel to be substituted for certain of the voice channels.

The frequency band employed for transmission over the cable extends from 12 to 60 kilocycles. The band below twelve kilocycles is not employed at present except for direct current on a few pairs which are used as pilot wires for controlling the automatic transmission regulators. Below about ten kilocycles the attenuation curve changes its slope rapidly and thus equalization and regulation become more difficult, while above ten kilocycles the slope is more nearly constant. This may be seen from the curve for non-loaded pairs at a temperature of fifty-five degrees as shown in Figure 1.

The twelve channels for the type-K system are obtained from the same channel terminal equipment as is employed in our other broad-band systems. This provides twelve sidebands in the range from 60 to 108 kc—the twelve carriers spaced 4000 cycles apart from 64 to 108 kc. The carriers are suppressed and the lower sidebands only are used. These high frequencies were selected chiefly because they permitted the use of crystal filters which, because of their sharp cut-offs, give efficient use of the total frequency band. Since over the cable the transmitted frequencies are

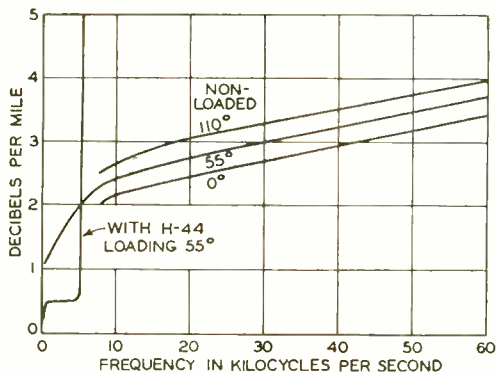


Fig. 1—Attenuation characteristics for loaded and non-loaded 19-gauge cable pairs

April 1938

from 12 to 60 kc, a second modulation, using a carrier of 120 kc, is employed to relocate the entire twelve-channel group into a 48-kc band directly below 60 kc. This double

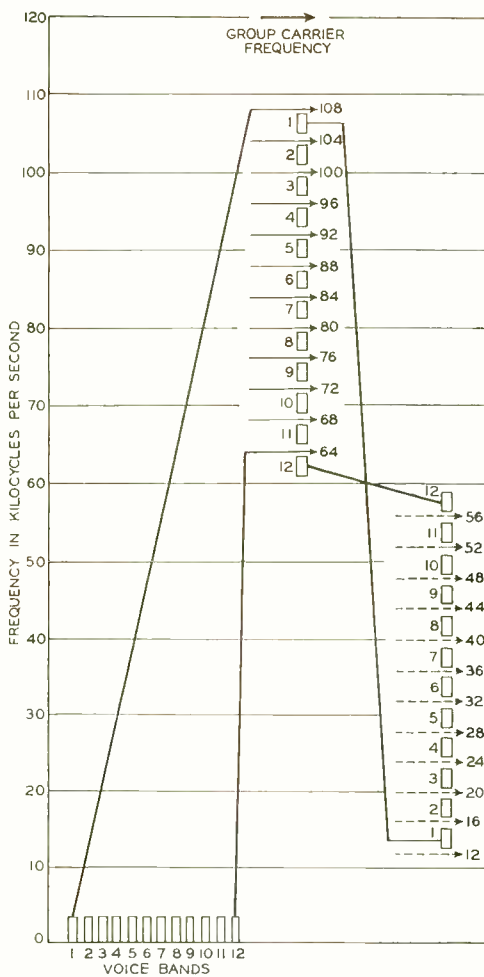


Fig. 2—By double modulation, twelve voice-frequency channels are first raised to occupy the band from 60 to 108 kilocycles, and then lowered to the band from 12 to 60 kilocycles for transmission over the cable

modulation is represented diagrammatically in Figure 2, where the twelve original voice channels are shown at the lower left. The channel modulators raise them to the band

from 60 to 108 kc, and these modulation as a group with the "group carrier," and selection of the lower side-band, relocates them in the band from 12 to 60 kc. The arrangement of the apparatus is indicated in Figure 3.

The attenuation of non-loaded cable pairs at carrier frequencies is very much higher than that of loaded pairs at voice frequencies. As indicated in Figure 1, a 19-gauge pair with H-44 loading, which is the type generally employed on long four-wire circuits, has an attenuation of about one-half db per mile at voice frequencies, while at 60 kc a non-loaded pair has an attenuation of nearly 4 db per mile, or roughly eight times as much. The loading gives to the cable pair the characteristics of a low-pass filter, and results in comparatively low attenuation up to about 5000 cycles with a very rapid increase above this point. Although very good at voice frequencies, such

loaded pairs are unsatisfactory for carrier operation, and the loading must accordingly be removed when carrier is applied.

To take care of this large increase in attenuation, increased gain has been provided in the repeaters and in addition they are located at shorter intervals; instead of the usual 50-mile repeater spacing for loaded cables, repeaters for non-loaded carrier circuits will be spaced about every 16½ miles—two repeater stations being added between the present repeater stations on existing lines. These auxiliary repeater stations have been designed so that they need no attention except for periodic visits for maintenance purposes. The existing repeater stations at the 50-mile intervals will be provided with alarms to give indication of troubles occurring in the auxiliary stations.

As shown in Figure 1, the attenuation of cable pairs varies not only with

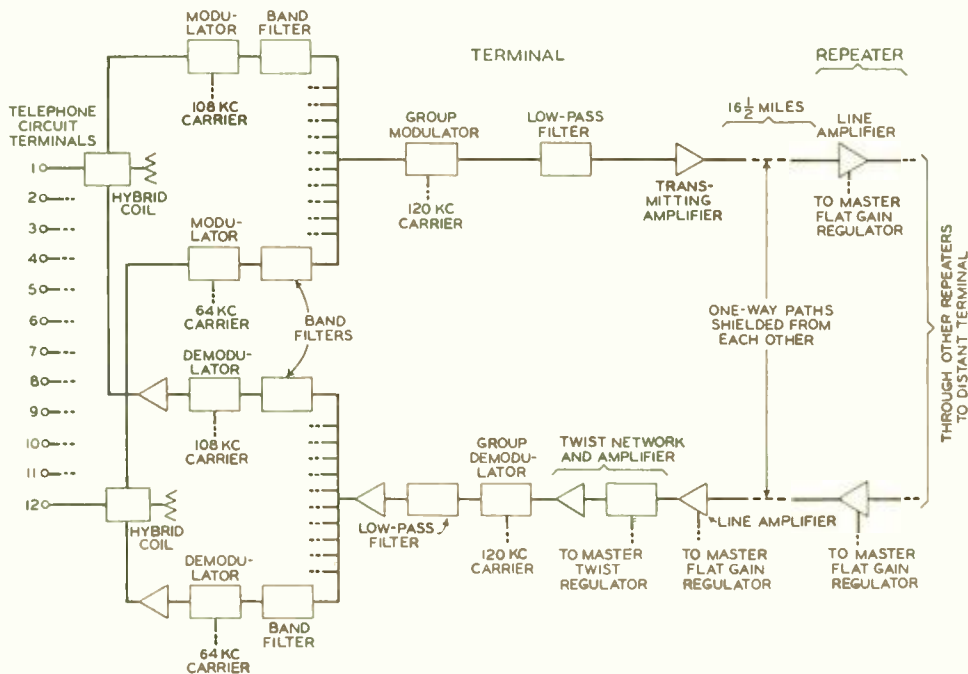
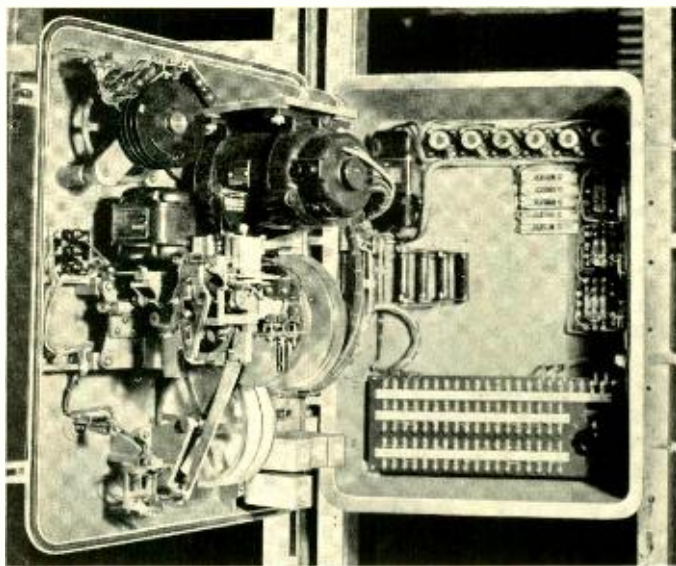


Fig. 3—Schematic arrangement of apparatus for the type-K cable-carrier system

frequency but also with temperature. A change from 0 to 110 degrees Fahrenheit will change the attenuation nearly 0.6 db per mile. Although this wide temperature range is found only over long periods of time — usually six months or so — temperature changes of 30 degrees occasionally take place within an hour on aerial cables. Because of these large changes in attenuation and the rapidity with which they may occur, automatic regulators

are provided to maintain the net loss of the overall circuit within satisfactory limits. These regulators control the repeater gains in accordance with the change in resistance of one of the pairs of the cable, which serves as a pilot wire.

The transmitting terminals and the repeaters have been designed to operate at output levels of the order of 9 db above that at the transmitting toll-switchboard. The loss at 60 kc of a 16½-mile repeater section at a temperature of 110 degrees is about 64 db, so the level at the input to the repeater would be about -55 db under these conditions. Some repeater sections will be longer than this, and amplifiers have been developed which are capable of providing a gain of about 75 db. Since there are very many amplifiers in tandem, it is essential that each amplifier be particularly stable with respect to fluctuations in the voltage of the power supply. They must also be unusually free from distortion to prevent interchannel interference, which would otherwise occur



*Fig. 4—The master twist regulator*

when so many channels are carried by a single amplifier. All of these characteristics are obtained by the use of stabilized feedback.

The feedback feature also provides a means for making the gain-frequency characteristic of the amplifier correspond approximately to the loss-frequency characteristic of the line. Heretofore, it has been common practice to equalize the line by networks which produce a loss complementary to that of the line, so that the combined loss of equalizer and line is constant for all frequencies. A flat-gain amplifier is then employed. By placing a suitable network in the feedback circuit, however, the amplifier gain is made to vary with frequency according to the attenuation curve for 55 degrees of Figure 1. Thus, the feedback amplifier itself equalizes the line at 55 degrees, and the regulators need only make changes in gain to correspond to the change in attenuation with temperature.

To perform this regulation, two types of regulators are employed. One,



*Fig. 5—J. P. Kinzer at the automatic transmission-measuring set, which measures net loss of complete circuit from 12 to 60 kilocycles in fifteen seconds. The sealed terminal bay is located at the right*

known as the flat-gain regulator, varies the gain of the repeater at all frequencies by an amount equal to the change in attenuation at 28 kc. It does this by controlling a variable air condenser in the feedback circuit of each repeater. Since the major part of the variation in gain made necessary by temperature changes is accomplished by this regulator, flat-gain regulators are installed at each repeater station on the cable route.

The change in loss with temperature, however, is not the same at all frequencies, and as a result, after the flat-gain regulator has operated there remains a small residual correction to be made at all frequencies but 28 kc. This deviation is known as twist

and correction is made by "twist" regulators. Because of the smaller amount of this regulation required, twist regulators are needed only at intervals from 100 to 200 miles. Instead of operating an air condenser, the twist regulator controls the operation of a switch associated with an adjustable network. As shown in Figure 3, this network is located in the output of the regular line amplifier, and a second amplifier is provided to make up for the losses in the network. The master controllers for the two types of regulators are similar except for such differences as are necessary because of this difference in the control element. In both cases, synchronous motors in the master controller and at the repeater are employed to make the change in gain.

The increase in the range of frequencies to be transmitted over the cables has made it

necessary to apply additional measures to reduce the crosstalk between pairs. This is accomplished by providing coils to couple each carrier pair to every other carrier pair; and the coupling of the coils is adjusted to balance out the crosstalk. To balance 100 pairs, which is the largest number planned for in any one cable, 4950 coils are required. For balancing purposes, each repeater section is treated as a unit and thus requires one such set of coils for each cable. Some re-splicing and transposing of pairs is required in addition to aid further in the reduction of crosstalk.

Because of the low levels reached on the carrier pairs, steps are required to prevent high-frequency noise caused

by reays and other devices at the voice-frequency repeater stations from entering the cable via its voice-frequency pairs and thence being induced into the carrier pairs. For this purpose, coils that introduce longitudinal impedance at carrier frequencies are provided in each voice-frequency pair at each voice-frequency repeater station. Additional precautions are also required where open-wire branch lines enter the cable. Within the office, all carrier equipment and wiring are carefully shielded.

One of the outstanding features of the new equipment is its compactness and small size. In the type-C carrier system, which was designed some years ago, approximately one bay of rack space was required for each two-way channel terminal, while with the new cable-carrier system, one such bay would accommodate twelve two-way channel terminals. This reduction in size has been effected through the use of new devices, such as copper-oxide modulators and demodulators, crystal filters, and new core materials such as permalloy, and through improvements in the design of many other parts. Other new features are hermetically sealed filters to avoid the effects of humidity, and sealed test-terminals, which provide in one unit a moisture-proof termination for outside cable, and jacks for testing lines and repeaters. Another important advantage of the telephone circuits of the type-K system is the high velocity of transmission which results from the use of non-loaded cable pairs.

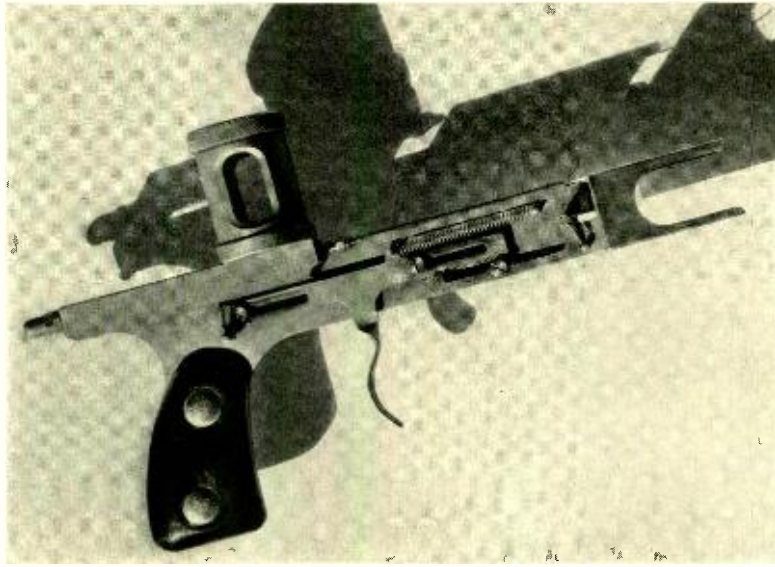
In addition to improving transmission performance and equipment design, further steps have been taken also to safeguard the service and to simplify maintenance. Pilot channels are provided which permit the performance of the system to be observed

while it is in service, and thus troubles may be detected before they become serious. Arrangements have also been developed for testing the vacuum tubes while the system is in service. The carrier supply, which is common to ten systems, is arranged so that in case of failure, within about two milliseconds an emergency supply will be connected automatically.

This application of broad-band carrier to existing types of cable represents another major step in the development of the carrier art. Besides making possible a larger number of circuits provided by the existing plant, its use should result in improved service and in more economical facilities.



*Fig. 6—M. M. Bower with the recorder that is used for measuring the resistance of the pilot wire during the trial period*



## Steel in the Telephone Plant

By I. V. WILLIAMS  
*Metallic Materials Engineering*

**B**ESIDES the steels employed primarily for their magnetic characteristics, which are not here considered, a quantity of steel—large both in amount and variety—is needed to meet the intricate and diverse requirements of the Bell System plant. Proper apparatus design requires a detailed knowledge of the various combinations of characteristics that may be obtained from the mixtures of iron, carbon, and other alloying substances that come under the generic name of steel. There are almost an infinite number of types available, with properties and prices varying over an equally wide range. Tensile strength will vary from 40,000 to over 400,000 pounds per square inch, with elongation from sixty per cent down to zero. Prices will range from a few cents to over a dollar per pound. Within these ranges steel can be found

to fit almost any set of properties that is desired except that, in general, high tensile values are nominally accompanied by low elongation and low impact resistance.

The properties of steel are chiefly controlled by the carbon content, the alloying components, the heat treatment, and the amount of cold working that the steel receives. An increase in carbon content tends to increase the tensile strength and to lower the elongation. Various alloying elements also have a tendency to increase the tensile strength without as great a decrease in elongation as results from the addition of carbon. The maximum effect of carbon or of the alloying elements on the physical properties, however, can be realized only by proper heat treatment. The importance of the heat treatment may be seen in the fact that a one per cent carbon



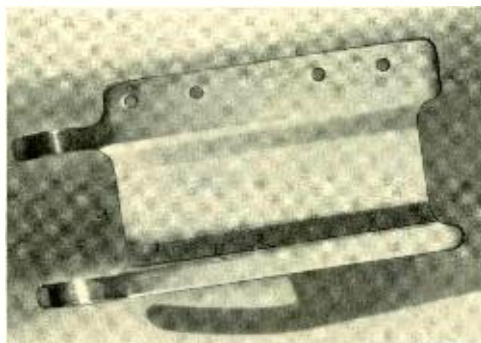
steel in the annealed condition may have a tensile strength of about 80,000 pounds per square inch, whereas by suitable heat treatment this tensile strength can be increased to 300,000 pounds per square inch.

Possibly the greatest amount of steel used in the telephone plant is employed for structural purposes such as racks and frames. These parts are made from low-carbon steel, the carbon usually being less than 0.3 per cent, and the parts are designed so that the stresses are not excessive for steel of this type. Structural steel is rolled to shapes that have been designed to distribute the stresses so as to allow the most economical use of the material. Low-carbon steel is also used for panels of various types. Here again the panels are so designed that the stresses are comparatively low, and full advantage is taken of the strength and stiffness of the steel. To permit painting or metallic plating, a smooth-finished sheet is ordinarily employed for this purpose.

Moving parts such as gears, cams, pawls, and bearings require widely varying types of steel. The choice will depend upon the severity of the working conditions which the parts have to undergo, and involves a study of the amount of abrasion or wear likely to occur, the amount of impact which can be expected, and the loads that

have to be withstood, as well as such special factors as corrosion.

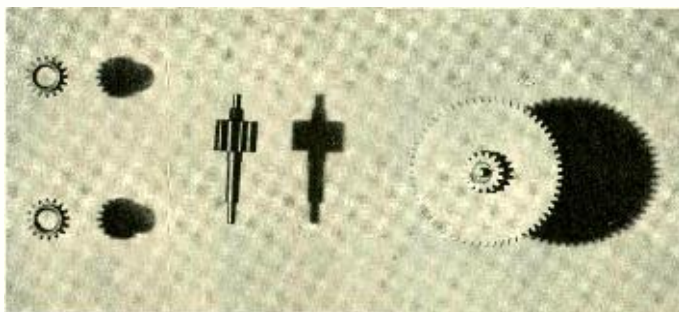
Lightly loaded parts that move at comparatively low speeds, and are not subject to shock, can be made of soft steel. As working pressures or speeds increase, or where shock or special wear conditions are encountered, some harder type of steel must be used. Usually a case-hardened steel or a



*Fig. 2—A nitrided film guide*

full-hardened steel is chosen for this work. The case-hardened steel is a low-carbon steel on which a hard surface has been produced by heating in some carboniferous material at temperatures ranging from 1400 to 1750 degrees Fahrenheit, followed by quenching or, in some instances, by special heat treatments to attain the desired physical properties. Full-hardened steels are of higher carbon content, usually from 0.5 to 1 per cent

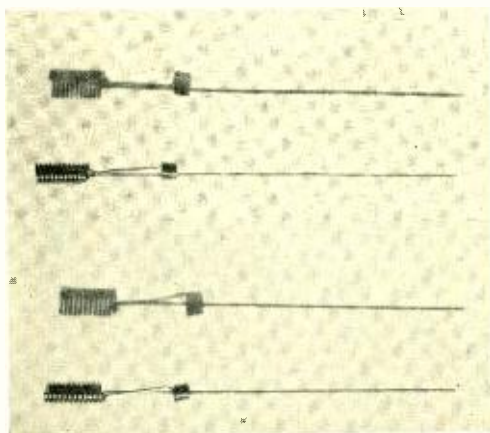
carbon, and may have alloying elements present. These steels are hardened throughout by heating to temperatures from 1375 to 1600 degrees Fahrenheit and quenching either in oil or water, depending upon the composition of the steel and the hardness de-



*Fig. 1—A group of pinions used in machine switching dials*

sired. They are then tempered by reheating at temperatures varying from 400 to 1100 degrees Fahrenheit. The case-hardened parts have soft cores and hard cases, and are usually considered most suitable for parts which are subject to high speeds or considerable impact. The full-hardened steels are considered more useful where slower speeds, higher loads and less impact are encountered. These special properties must be borne in mind when specifying the steel for a part which is to be subjected to wear.

For applications where high speed and light pressures are accompanied by severe abrasive conditions, nitrided steels have been found particularly useful. These are steels which have been particularly designed to permit hardening by the formation of nitrogen compounds. The alloying elements used are generally aluminum, chromium, and vanadium, which assist in the formation of the hard case. Other alloying elements are sometimes added to produce special properties, such as greater elongation and shock resistance. The method of hardening consists in heating the steel in a



*Fig. 3—Selecting fingers for the crossbar switch are made from spring stainless steel. The properties of this type of steel approach those of music wire*



*Fig. 4—This dial for colored handsets has stainless steel finger wheel and finger stop*

sealed chamber at a temperature of approximately 1200 degrees and passing ammonia over it while it is at this temperature. The ammonia breaks down to provide nascent nitrogen which forms nitrides with the components of the steel. These nitrides form a harder case on the surface of the steel than can be produced by any other method. Because of the extreme thinness of the case, its exact hardness is very difficult to determine, but various investigators have estimated that it is between 800 and 1000 Brinell, whereas the ordinary steels cannot be hardened much beyond 650 Brinell.

Nitrided steel proved particularly valuable for the film guide in sound picture apparatus, to mention one application. This guide is subjected to continual rubbing as the film passes over it at high speed and with an intermittent motion that produces a slapping effect. Many materials were tried for this part, including chromium-plated brass, tool steel, both plain and chromium-plated, and case-hardened steel. All wore out very rapidly. It was then decided to try

ni steel, which was a new development at that time, and the guide wore very satisfactorily and was adopted for use.

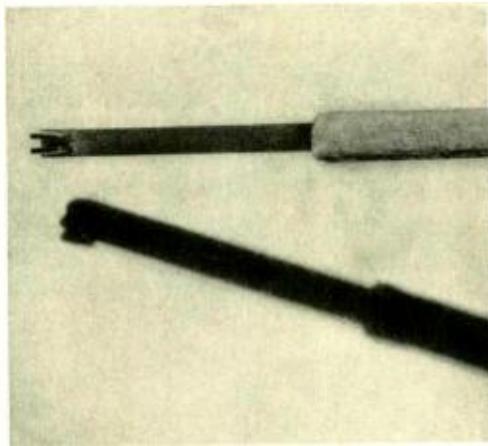
Springs are among the most important pieces of telephone apparatus made of steel. These are of many types, one of the most important being the helical-wound springs, which are generally made of music wire. Due to its special method of manufacture, music wire is the strongest of ordinary engineering materials. It develops a tensile strength of over 400,000 pounds per inch in the small sizes, and yet can be kinked without breaking. Springs of this material are particularly resistant to shock and, if worked below one-third of their tensile strength, have very good fatigue resistance.

Another type of spring material used in large quantity is clock-spring steel. This is another material that requires a very special manufacturing method since it is hardened in long strips of several hundred feet. Tensile strengths of 300,000 pounds per square inch or better are obtained. Although these springs do not have the ductility or resistance to shock of the music-wire springs, they have higher fatigue limits and can be worked at higher stresses.

There are other springs which require the properties of clock-spring steel, but which, because of their shape, cannot be formed in the heat-treated condition. For these applications a clock-spring steel composition is used but the parts are heat treated after forming. This is a more expensive method of manufacture, but has to be employed in many instances.

Widely used of late are the stainless steels. These fall roughly into three classes, those containing approximately 13 per cent of chromium, which are capable of being hardened

by heat treatment; those containing sufficient chromium, generally 16 per cent or more, so that the resulting steel will not respond to heat treatment; and a group containing nickel and chromium. These latter steels do not respond to heat treatment, and usually contain a minimum of 17 per cent chromium and 7 per cent nickel. The percentage may run much higher than this, but the ratio between the two alloying elements is usually constant. This group is the most resistant



*Fig. 5—An alloy steel tool in which space limitations demand the use of material of high strength*

to corrosion, and the corrosion resistance increases with the increase of alloying elements.

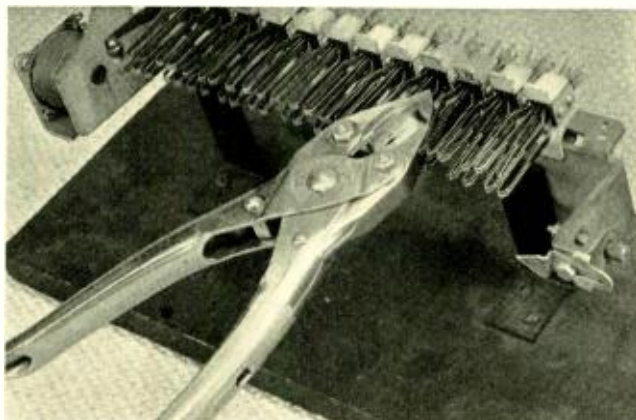
A rather specialized use of steel, and one for which stainless steel is particularly fitted, is for escutcheon plates and other parts subjected to handling, in which appearance is an important factor. Because of the high polish that stainless steel will take, and because of the high resistance to corrosion that it exhibits, it is becoming much more popular for such uses. The escutcheon plate on the coin-return chute of the coin box is one place where this steel is now being

used. It is also being used for dial finger wheels for colored handsets.

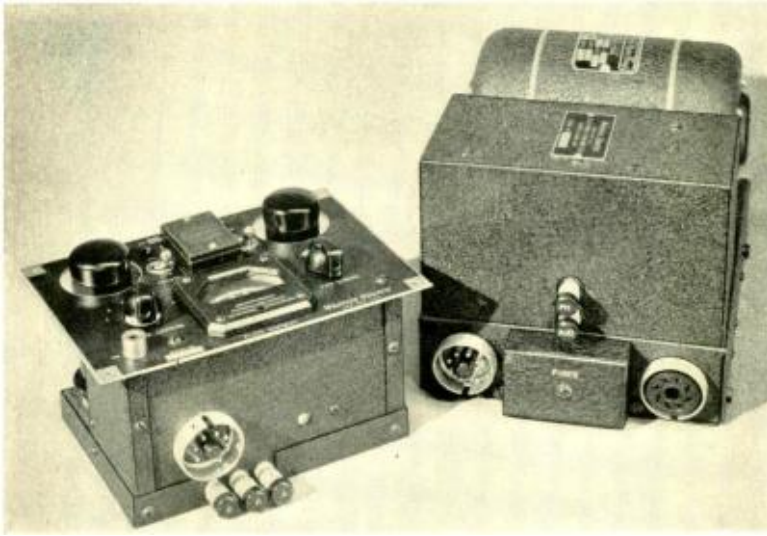
Tools used in the maintenance of telephone apparatus use a large amount of steel, and the choice of a suitable type is of considerable importance because of the severe service to which these tools are put. Some tools, where the size is large enough to permit the stresses to be kept at low values, can be made of cold-rolled steel. This material makes an inexpensive tool, which if properly used, is generally very satisfactory. Because of the space limits encountered in using most of the Bell System tools, however, the stresses developed are very high, and as a result the tools usually have to be made of a high-grade, high-strength material. Case-hardening is employed in some instances. This is the intermediate step in the improvement of the tools, the final step being the use of high-carbon steels or of medium-carbon alloy steels.

Since it is desirable to keep the number of stock items required as small as possible, an attempt is made to use one or two materials for tools.

Carbon tool steel of approximately 1 per cent carbon, or a chrome-vanadium steel containing about  $\frac{1}{2}$  per cent carbon, 1 per cent chromium, and  $\frac{1}{4}$  per cent vanadium, is generally employed. Because the alloy steel is somewhat cheaper than high-carbon tool steel, and exhibits better properties for tools, most of the new tools are made from this material. Hardness is varied to suit the purpose for which the tools are to be used by changing the temperature at which the tools are tempered. By varying the hardness it is generally possible to make a satisfactory tool for any purpose from one or the other of the two steels mentioned. An exception was a tool for cleaning message-register switches. This consists of a device for agitating the catch on the message register and, at the same time, squirting carbon tetrachloride on the bearings. It was found that carbon tetrachloride etched most of the materials which were tried for this use. Steel of the 18 per cent chromium, 8 per cent nickel type was found to be satisfactory for this use, and the tool was made up entirely of this material.



*Fig. 6—Sequence switch springs are cut in the mounted position on the frame with the rotor removed by means of this splitting tool in which a very hard steel is used for the cutting blades*



## A Multi-Frequency Transmitter for the Private Plane

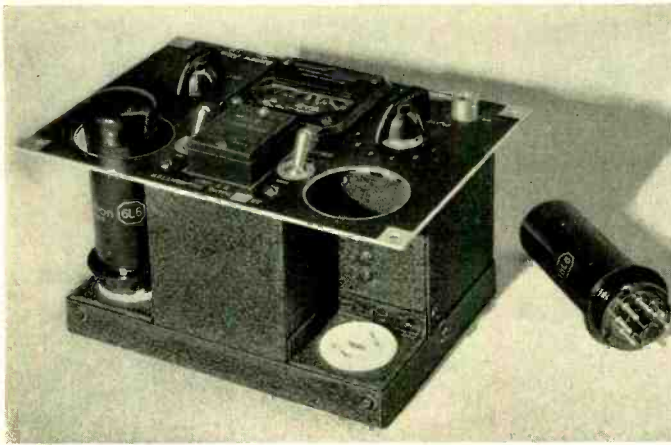
By E. A. BESCHERER  
*Radio Development Department*

THE importance of radio to air transportation is too well known to require emphasis. Radio receivers are used almost continuously on transport flights to follow radio beacons and to receive weather reports, and two-way communication is employed to make periodic reports to the airline headquarters and to communicate with the airport officials before landings. What is perhaps not so commonly known is that while there are some 400 planes operating on scheduled airline flights, there are nearly 9000 coming under the classification of private planes. Although these private planes in general are small and do not need such elaborate equipment as the transport planes, they do a great amount of all-weather flying, and must be able to receive beacon signals and weather

reports, and communicate with Department of Commerce Stations, and with airport officials to receive landing instructions.

With the needs of the private flyer in mind, the Western Electric Company has had available for a number of years radio equipment\* particularly arranged for the small plane. Weight is always important in an airplane, but the difficulty in providing radio transmitters for private planes is largely one of meeting space requirements. For the most part the private planes are small, and space within reach of the pilot is at a premium. Even though the previous transmitters have been small, it has been necessary either to place them where they were not easily accessible, or to provide a

\*RECORD, December, 1935, p. 136 and January, 1936, p. 161.



*Fig. 1—The radio-frequency unit of the 25A transmitter, showing the external mounting of the tubes*

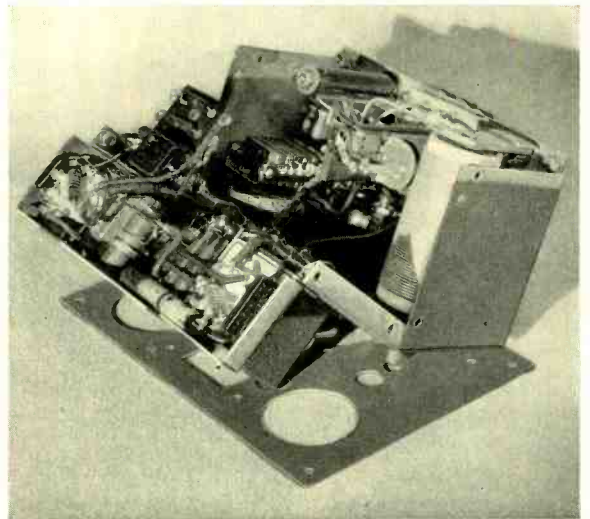
control and tuning unit on the instrument panel with the added weight and expense of flexible shafting that it requires. This difficulty, which has heretofore seemed unavoidable, has now been overcome by a radically new design. The 25A radio transmitter is the result.

An outstanding feature of the new design is the construction of the transmitter in two parts; a radio-frequency unit, which incorporates the tuning elements, and a power and audio unit, which includes the remainder of the transmitter and the dynamotor. The radio-frequency unit is small enough to be mounted directly in the instrument panel, thus permitting direct tuning, and making it simple to substitute other quartz plates when the operating frequency is to be changed, while the other unit, which requires no attention, may be mounted in any convenient place in the plane.

The radio-frequency unit, shown in Figure 1, is approximately  $6\frac{1}{4}$  inches wide,  $4\frac{1}{2}$

inches high, and 4 inches deep. The face-plate, which covers the front of the unit, extends beyond these dimensions sufficiently to permit mounting the transmitter flush in the instrument panel. The two vacuum tubes and the quartz plate holder, which are included in this unit, project through the cover plate. This makes it very easy at any time to change the

transmitting frequency by changing the quartz plate holder. Only a single quartz plate is provided as standard equipment with the transmitter, but the holder is of the double type so that two crystals may be used if desired. A small switch directly at the left of the holder permits the desired crystal to be selected as needed. On the front of the face plate are all the controls needed to operate the trans-



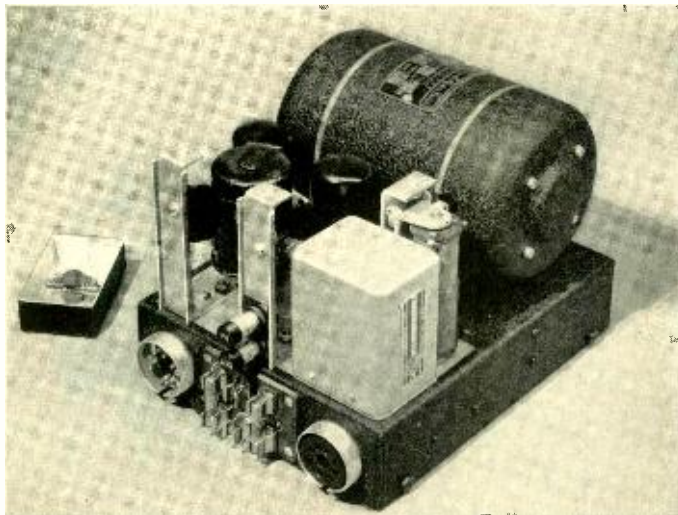
*Fig. 2—The radio-frequency unit with face plate removed and the unit open at the hinge*

mitter. In addition to the crystal switch, there is included a power switch for connecting battery to the filaments, an antenna-tuning control, a plate-loading switch, a plate-current meter used for tuning, and a jack for the microphone. The receptacle for the multiple-conductor cord connecting this unit to the power and audio unit is mounted on the chassis behind the instrument panel, and is evident in the photograph at the head of this article.

Although the division of the transmitter into two parts made it possible to place all the apparatus used for control or tuning within the narrow limits of the radio-frequency unit, the construction and maintenance of the set would have been difficult but for another innovation. This is the arrangement of the radio-frequency unit itself in two parts, which are hinged together and may be opened like a traveling case for assembly or maintenance. This is indicated in Figure 2, which shows the unit open at the hinge. Without this provision the necessary compactness of the assemblage would not only have retarded the original assembly, but would have made the replacement or repair of the parts exceedingly slow and difficult, since to reach some of the elements within the unit many other elements would have to be removed. The two parts when closed are fastened together by two screws on each side, and the face plate, which is removed for opening the unit, is

fastened both to the unit and to the instrument panel.

Another novel feature is the mounting of the two tubes external to the unit itself, so as to provide ample air circulation for cooling. This arrangement may be seen in Figure 1. The body of the unit is in the shape of a T



*Fig. 3—The audio and power unit with cover removed*

with a short stem, and one tube is mounted on each side of the stem. The quartz plate holder projects through the faceplate into the stem of the T, and the unit is hinged in the cross of the T just behind the tubes. Further accessibility to the high-frequency unit is provided by making the two side plates of the stem of the T removable.

The power and audio unit is shown in Figure 3, and in the photograph at the head of this article. Mounted on the rear of the base is the dynamotor, which is driven from the ship's twelve-volt battery, and supplies high voltage for the plates. On the front of the base is the audio amplifier, the relay for starting the dynamotor, and a control relay. This latter relay oper-

ates the dynamotor relay and the antenna relay in the high-frequency unit for transferring the antenna between receiver and transmitter. On the front of the base of this unit are two receptacles—one for the multi-conductor cord to the radio-frequency unit, and one for the cord to the battery. Between these receptacles are three fuses under a common cover. One of the fuses is in the high-voltage circuit, one in the filament circuit, and one in the main power circuit. The cover is equipped with clips that fit over the main fuse and withdraw it when the cover is removed. This avoids the possibility of anyone's coming in contact with the high voltage when changing a fuse. The binding posts shown are for connections to the radio receiver and antenna.

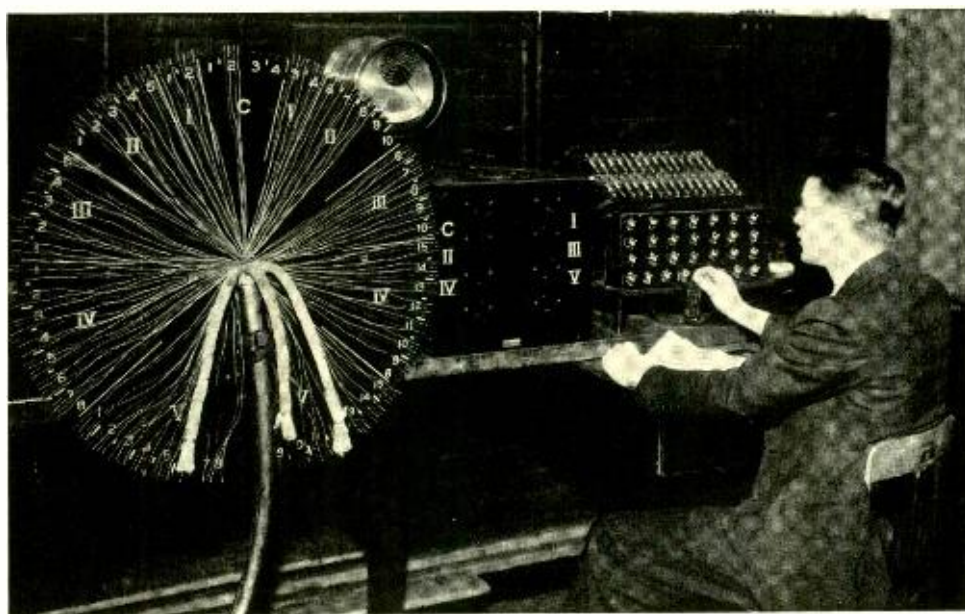
Operation of the set is very simple. With the desired quartz plate in place and the power switch in the "on" position, the six-position loading switch is turned to a predetermined position dependent upon the frequency, and the tuning control is then turned until the needle of the plate current meter makes a marked dip, indicating a resonance. Other crystals may be substituted for the one with which the set was tuned without the necessity of retuning provided the frequency change is not greater than five per cent. The microphone includes a press-to-talk switch. With this switch released, the antenna

is connected to the radio receiver, and the transmitter is disabled. When the switch is pressed, relays operate to start the dynamotor, to transfer the antenna to the transmitter, and to provide sidetone for the head receiver.

This simple operating procedure is made possible by the electrical design of this transmitter, with which A. G. Fox has been associated. One of the unusual features is the employment of a band-pass transformer as a coupling between the oscillator and power amplifier. This transformer is designed to pass the full rated frequency band of the transmitter from 2.8 to 6.4 megacycles, and eliminates all oscillator and interstage tuning. This frequency band includes the frequencies available to private flyers and transport planes.

The complete transmitter, including both units, the crystal, the microphone, and the connecting cords, weighs only twenty-three pounds, provides fifteen watts of carrier power, and is capable of substantially complete modulation. Although intended primarily for telephone transmission, it may readily be adapted for either continuous-wave or modulated continuous-wave telegraph transmission. The two units with tubes, connecting cables, and microphone are packed in a single carton and the only ordering information required other than the code number of the transmitter is the frequency of the quartz plates.





## Improved Methods in Cable Testing

By E. C. WEGMAN  
*Cable Development*

**B**EFORE the Western Electric Company ships a lead-covered telephone cable it is subjected to a series of careful tests. These tests are of necessity limited to those which can be made without affecting the suitability of the cable for its use in the field; that is, they are not "destructive." There are qualities, however, which must be provided for in the design of the cable the presence of which can only be determined by destructive tests. Tests of this character can be applied only to sample lengths. Destructive tests are very important in the development studies of possible designs and from time to time may be used as checks on manufactured product.

One important requirement for a lead-covered cable is that it shall not suffer serious damage in the usual

handling to which it is subjected in the field, where it must be pulled through conduits and bent into position in manholes. The suitability of new or substantially changed designs of cable from the standpoint of such handling in service could be investigated under field conditions by actually pulling a full length in and out of conduit and by setting it up in manholes and splicing. Since installation conditions vary widely, however, and since actual field trials of this kind destroy substantial amounts of cable and involve much time and labor, specific tests of a laboratory character are desirable, which can be applied to short lengths to determine, at least in a preliminary way, the handling properties of cable. A variety of possible procedures that would simulate treatment in the field were investigated;

and four tests were finally selected which would determine the effects on the core, on the paper wrapping, and on the sheath of various types of bending and pulling. Two of these are comparatively simple bending tests, which can be made by hand on a laboratory bench. The other two are pulling and sheave tests performed as indicated in Figures 1 and 2.

In one of the hand bending tests, the cable is bent around a mandrel in the horizontal plane and then given a reverse bend of equal magnitude in the same plane. In the second test it is similarly given two bends but in planes at right angles to each other. In both of these tests the bends are first made at comparatively large radius, and if no damage is noted, the radius is progressively decreased until damage becomes evident, either from the appearance of the sheath itself or from high voltage breakdown tests between conductors or between conductors and sheath. In the pipe and sheave tests the procedure is somewhat similar but for these it is the load, or tension, applied to the cable that is progressively increased.

While the effects of these tests are frequently evident on the sheath, the damage is often inside the sheath, and can be revealed only by measurements of the dielectric strength. Such measurements have usually been made by applying an alternating potential to the cable conductors, and increasing the voltage until breakdown occurs. The objection to this method is that the large rush of current that follows the breakdown not only burns out the fault but damages the neighboring conductors. As a result no further tests can be made on the cable. To avoid this objectionable feature a new circuit has been arranged for the dielectric test which limits the current at breakdown, and as a result the cable is not damaged. In fact, on a second application the cable will break down at almost the identical voltage that caused the first failure. For this new test, direct current is employed, and the circuit is arranged to cut the current to a low value when breakdown occurs. An examination of the cable after breakdown discloses a very fine hole which is too small to have any detrimental effect on the quality

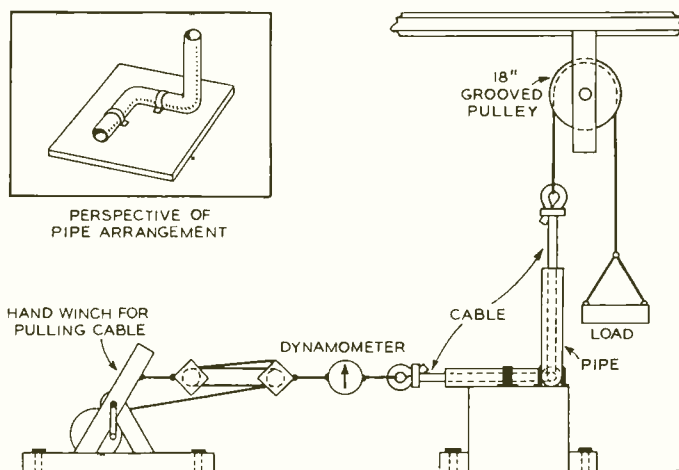


Fig. 1—In the pulling test a short length of cable is pulled through a pipe with a double bend under various loads

of the cable. With repeated flashes the hole becomes larger. Its size, magnified fifteen diameters, is shown in the upper part of Figure 3, while below—for comparison—are shown, magnified in the same ratio, the harmless holes made by a splicer's test pick, which has points about the size of a sewing needle. These dielectric tests are applied to cables both to determine their normal

own strength and in conjunction with the bending and pulling tests to determine when the cable has been damaged.

In applying this d-c breakdown test, the voltage is increased in steps of 100 volts, beginning at a potential at which it is believed no failure will take place. Each voltage is maintained for ten seconds and then re-applied at least three times before going to the next higher step. Such a procedure is found desirable because sometimes conductors will fail on the second or third application, which did not fail on the first.

When used in conjunction with the mechanical tests, the breakdown is generally determined first. If the cable then breaks down at a lower voltage after the bending or pulling test, it is an indication that damage was done, while if it breaks down at the same value as at the initial test, it is assumed that the bending or pulling caused no particular damage. The dielectric strength data obtained in the initial test, before the cables are handled, is also of considerable value for comparison between different types of cables. They also indicate the factor of safety between the guaranteed dielectric strength and the actual dielectric strength.

Experience with these mechanical tests has shown that the bending tests affect principally the sheath and the wrapping paper around the core, and will show any tendency for the core itself to become kinked or buckled. The pulling tests, on the other

hand, affect the dielectric strength of the insulation more than the bending tests do. They also show the maximum safe load for the various sizes and types of cable. The dielectric strength test is of value principally in conjunction with the pulling test, and in many cases will show evidence of material weakening of the insulation when visual examination shows practically no evidence of damage. Experience with various types of bending tests has also shown that a very decided kinking of the core can occur with no evidence of any appreciable loss in dielectric strength.

The use of these mechanical handling tests has so far been confined almost entirely to direct comparisons of similar sizes of different types of cable. They were of great value, for example, in the development of pulp insulated and unit type cables by permitting a comparison between the handling qualities of these cables and the ribbon-insulated layer-type cables that had been standard for many years. It now seems probable that as additional data are obtained, there will eventually be available sufficient

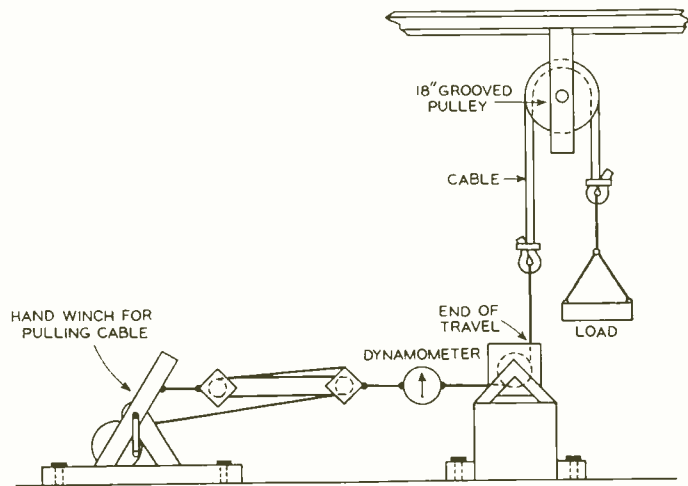
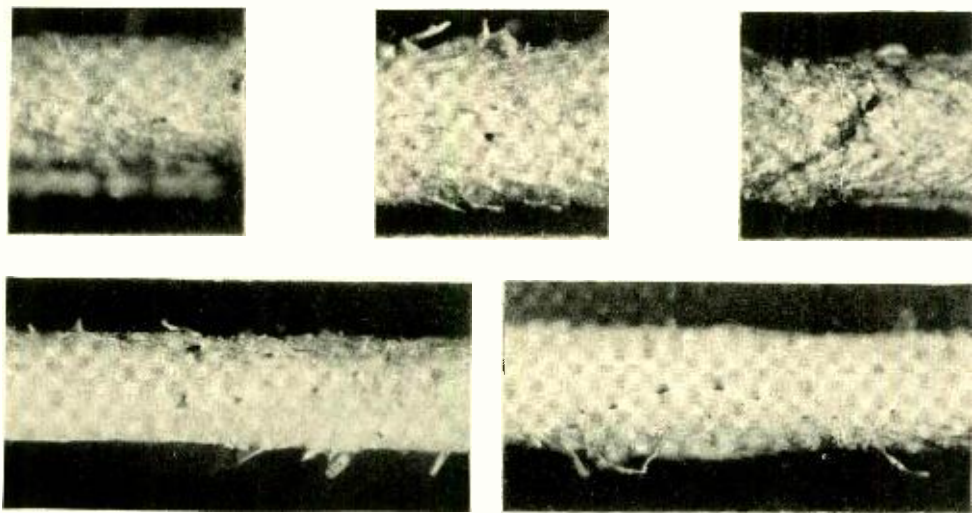


Fig. 2—In the sheave test the cable is pulled over a sheave to determine the effect of bending at various loads

information to provide a definite measure of handling quality by which new designs of cable may be gauged. While these laboratory tests are very

useful in predicting the probable behavior of cables under service conditions, practical experience must always guide the final judgment.



*Fig. 3—Holes made by the dielectric tests, of one, five, and fifteen flashes—from left to right above—are small compared to those made by a splicer's pick, shown below. All photographs are fifteen times actual size*



*This country is entitled in good times and bad to the best possible telephone service at the lowest possible cost. The success of the American Telephone and Telegraph Company and its Associated Companies must be measured by that standard and depends on giving at all times, day and night, dependable, accurate and speedy telephone service, constantly improved and extended in scope by research and invention, at a cost to the users as low as efficient operation can make it, consistent with fair treatment of employees and such return to the stockholders as will insure the financial safety of the enterprise.*

—WALTER S. GIFFORD



## High-Speed Motion-Picture Photography

By W. HERRIOTT

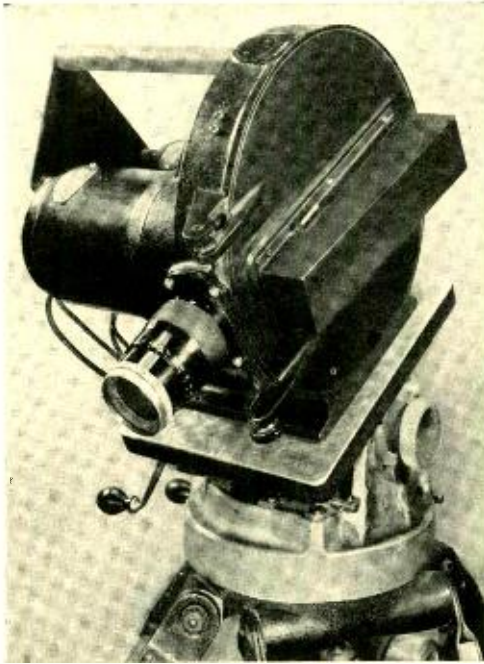
*Electromechanical Development*

**M**ECCHANICAL movements too rapid to be seen directly can be analyzed by photographing them on motion-picture film at high speed and then projecting at low speed. For several years the Laboratories has used this method as a visual aid in problems associated with the design, manufacture and performance of telephone apparatus. It has been applied to dials, relays, keys and ringers, and in investigations of impacts and other stresses. In the study of transient movements such as contact-chatter it has been par-

ticularly valuable. This method avoids the limitations of the rapid oscillograph which can photograph only small areas.

Photographic records of the motion-picture type give definite space-time relationships between moving parts. Space measurements are made on projected images, or on enlarged prints; and time is determined either from the taking speed or by photographing a clock face that is placed at the side of each picture.

This apparatus, as developed in our Laboratories, involves a camera of



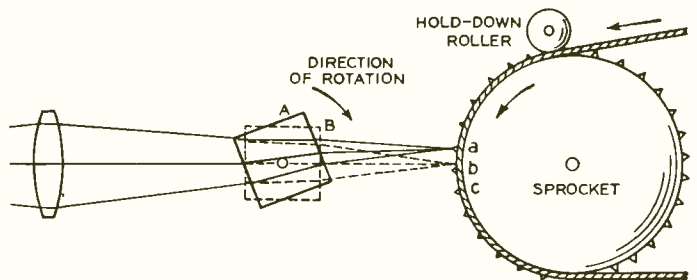
*Fig. 1—This high-speed camera takes 4,000 pictures per second. By projecting them at the normal rate of from sixteen to twenty-five per second, rapid mechanical movement can be slowed down and analyzed*

special design, shown in Figure 1. It operates normally at a speed of 4,000 pictures per second and instead of a shutter it has a small cube of glass which rotates at high speed between the lens and the film. When light from an object passes through this rotating cube it is deviated by refraction through an angle which depends on the orientation of the cube. This orientation changes continually as the film moves through the camera. By correct choice of the index of refraction, of the dimensions of the cube and of the relative rates of motion of cube and film, the image is

kept stationary on the moving film as it passes the camera gate. One picture is taken for each quarter revolution of the cube.

The rays from a point of the object are converged by the lens on the front face of the cube, as shown at "A" in Figure 2. There, they are refracted to the opposite face and pass through it to form an image on the film at "a." When the film has reached a point "b" on the lens axis, the compensator has rotated to the position "B." Further rotation on the prism causes the image to follow the movement of the film downward toward "c" and allows the exposure of an elemental area of the film to continue during a substantial part of the exposure cycle. The duration of each exposure is controlled both by the speed of rotation of the compensator and by the angular height of an aperture in front of each of the four faces of the cube.

The cube rotates on a ball-bearing shaft 1,000 times per second when taking 4,000 pictures a second. It is driven by spur gears from a main shaft which connects directly to a  $\frac{1}{2}$ -horsepower motor. A toothed sprocket propels the film; it is directly attached to the main driveshaft of the motor and rotates at 12,000 revolutions per minute for a taking speed of 4,000 pictures per second. One-

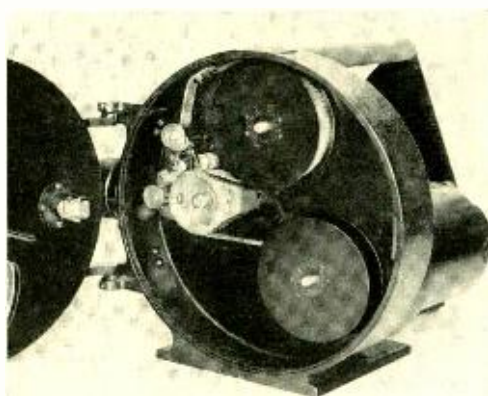


*Fig. 2—A glass cube which rotates between the lens and the continuously moving film deflects the light rays enough to keep the image fixed on the film*

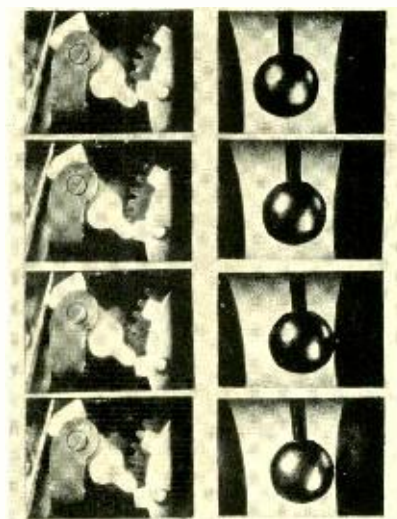
hundred-foot lengths of sixteen-millimeter supersensitive panchromatic film are used. They have twice the usual number of perforations for better distribution of the stresses which occur during acceleration. The loaded film-spool is placed on the upper spindle as shown in Figure 3; and the film is threaded under a guide roller onto the main sprocket and to a take-up spool, which is driven by a separate motor. A finder with a hooded ground-glass screen is attached to the hinged door of the camera. Interchangeable lenses of various focal lengths are mounted on the front of the camera; and a firm portable tripod is provided.

Since the effective exposure for each picture is of the order of  $1/10,000$  second, or less, intense light sources must be used to illuminate the subject. Portable lighting units of the types shown in the headpiece have been developed for this purpose. They employ both carbon arcs and tungsten lamps, and give intensities of illumination of the order of 10,000 to 500,000 foot-candles. Liquid filters absorb most of the heat they radiate.

High-speed photography is now

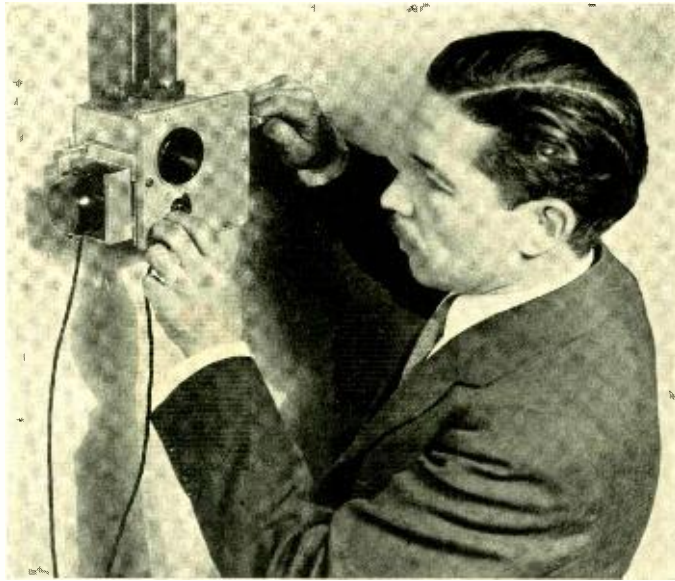


*Fig. 3—The film is exposed as it passes around the sprocket from the upper to the lower reel*



*Fig. 4—The high-speed motion pictures at the left illustrate the action of the impulse wheel, pawl and snubbing spring in a telephone dial. At the right is shown the action of the clapper striking one gong of an experimental ringer. These photographs were taken at the rate of 2,000 per second*

being applied extensively in industry for the "motion analysis" of a wide variety of manufacturing operations and in problems associated with the design and performance of machinery. Automotive engineers use it to study vibration and the rates of combustion of fuels in motors. In aeronautics it finds application in investigating air flow around structures and in propeller design and performance. It is frequently used in ballistic studies and to time athletic events and is coming into use in the fields of biology and medicine to study nervous and muscular reactions under controlled conditions. At the Laboratories high-speed photography is available as a service to engineers. The high degree of portability which has been achieved both in the camera and lighting equipment makes it suitable for extensive application in a wide variety of problems.



## New Magnetic Telephone

By G. E. ATKINS  
*Apparatus Development*

**T**ELEPHONES which had no source of energy other than the speaker's voice were the earliest commercial instruments. A diaphragm of soft iron served both as a collector of sound energy and as a means of varying the flux through a coil. Voice currents generated in this instrument were far less powerful than those given by the carbon-granule transmitter, which soon came to dominate the field. A magnetic transmitter, however, is simple, portable, and independent of current-supply, and it would be attractive for use in construction camps, warehouses and ships. Better knowledge of magnetic materials and structures has suggested that its output could be greatly increased by proper design.

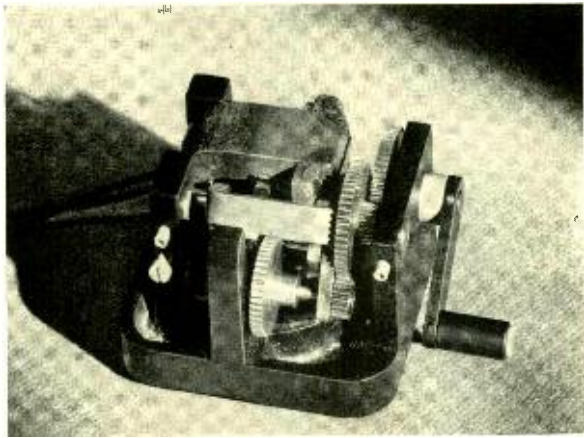
In the magnetic telephone which is the outcome of recent development

work in these Laboratories, a cone-shaped duralumin diaphragm is connected to one end of an armature which lies between the poles of a U-shaped permanent magnet. When sound waves strike the diaphragm the armature vibrates and varies the air-gaps between it and the pole-pieces of the magnet. This changes the reluctance of the magnetic circuit and induces voice-frequency currents in a coil which surrounds the armature but does not touch it. Conversely, when voice currents are imposed on the coil, the armature and diaphragm vibrate and reproduce speech. Thus, a single instrument serves alternately as transmitter and receiver.

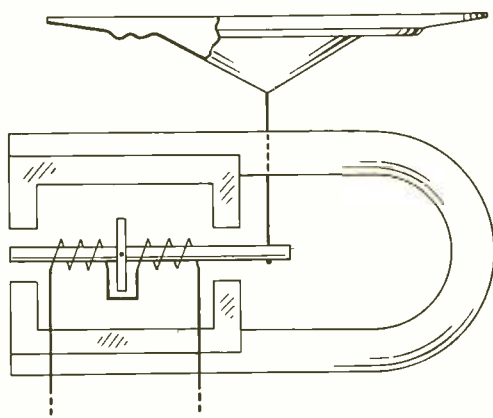
Signalling current is generated at either end of the line by varying the reluctance of the magnetic circuit of the telephone instrument rapidly



enough to create an audio-frequency current. Near the ends of the armature are two discs with teeth of magnetic material; both discs are attached to the same spindle and mounted at the side of the magnet as shown in Figure 1. Their action is illustrated in Figure 3 where the parts are shown in their correct positions except that the two rotors have each been turned ninety degrees for clearness of illustration. The total gap from either pole-piece to the armature by way of the rotor tooth is substantially less than the distance between the pole-piece and the armature. Also, the rotors are displaced angularly so that the left rotor is in position to shunt the air gap between the north pole and armature when the right rotor shunts the gap between the south pole and armature, and vice versa. This makes the flux pass from the left end of the north pole-piece to the tooth of the left-hand rotor, thence, through the armature to the tooth of the other rotor, and to the right end of the south



*Fig. 1—The new magnetic telephones have a powerful permanent magnet. The diaphragm itself emits a siren-like tone to signal the person called*



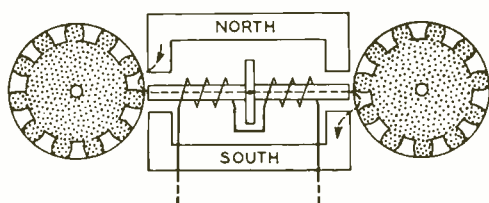
*Fig. 2—The diaphragm is attached to a rocking armature similar to those used in certain types of loudspeakers*

pole-piece. Similarly, when the rotors have progressed a little farther the flux goes from the right-hand north pole to the left-hand south pole through the armature. In this manner the flux through the armature is reversed periodically and an alternating current is induced in the coil. The rotors are driven from a hand crank through a gear train so that the frequency of the current is in the order of 1,000 cycles per second. This frequency lies not only within the peak of the response curve of the instrument but at a value where the human ear is relatively sensitive. The acoustic level of the signal is very much higher than that of the standard telephone ringer.

To obtain an efficient magnetic circuit with small lightweight parts, the magnet in the telephone structure was made of remalloy, a highly remanent material. Pole-pieces, armature and teeth of the rotors are made of permalloy; the teeth themselves are separated by non-magnetic material in order to reduce leakage.

A five-foot cord, the two conductors of which terminate in clips of conventional design, is provided to attach

the telephone to a permanent or a temporary line. A small leather carrying case with a shoulder strap is also available. The instrument itself is



*Fig. 3—The signalling current is generated by rotating two discs with teeth of magnetic material in the field of the telephone magnet*

about three inches square and weighs less than two pounds.

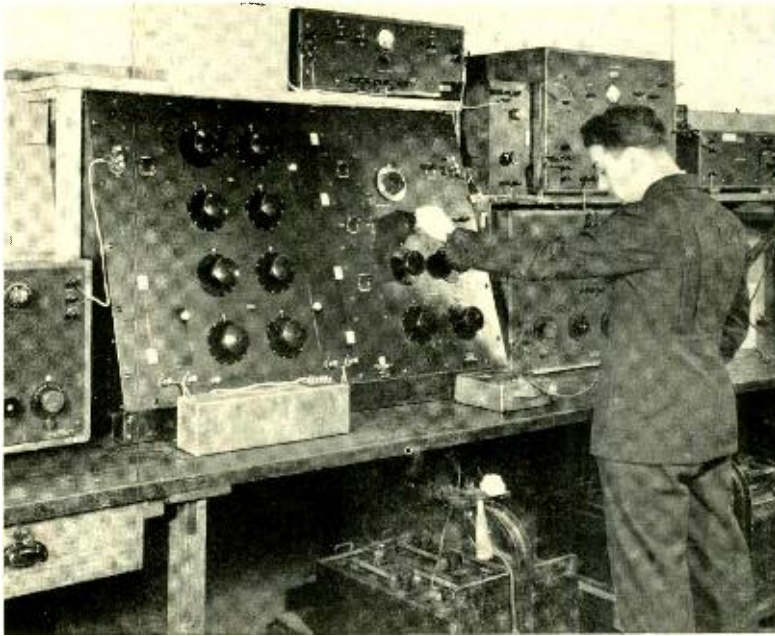
A wall-type telephone embodies a transmitter which functions as a signal generator and reproducer, and a receiver which differs only in the lack

of signalling facilities. Removing the receiver from its mounting transfers the telephone from the signalling to the talking circuit and, in order to prevent signalling under talking conditions, short-circuits the line when the signalling crank is turned. A switch is provided to connect the set to any of six outgoing lines. This telephone, being designed primarily for installation on shipboard, is watertight and is shown on page 282.

These new magnetic telephones are not intended for connection with Bell System private-branch exchange or central-office service but their quality and efficiency makes them useful for intercommunication service where compactness, independence of external power, and ease of installation are important.



*Fig. 4—The combined transmitter and receiver is three inches square and weighs less than two pounds*



## Precise Measurement of Insertion Phase Shift

By J. S. ELLIOTT

*Telephone Apparatus Development*

**I**N the operation of communication circuits, the phase-shift characteristics of the component units tend to introduce distortion due to delay in the transmitted signal. To control this form of distortion, it is necessary to determine accurately the amount of phase shift contributed by the various circuit elements. Suitable measuring apparatus has been available for this purpose in the past, but in recent years the transmission requirements for high-quality program and picture transmission circuits, and for certain of the carrier systems, have become more exacting. Not only are measurements required over a wider range of frequency and loss, but greater precision is needed. As a result

new measuring equipment has been developed of wider range and considerably greater precision. It can be used for measuring phase-shift angle of four-terminal networks, such as filters, equalizers and phase correctors, over the frequency range from 20 to 75,000 cycles to an accuracy of one-sixth of a degree when the network insertion loss being measured does not exceed 30 db.

The basic circuit is shown schematically in Figure 1. A test potential is supplied by an oscillator to both a standard attenuator and the apparatus under test; and the outputs of these two branch circuits are brought to opposite corners of an equal-arm bridge network, one arm of which con-

sists of a detector and the attenuator used for measuring the phase shift. Connected in the circuit on the input side of the bridge network is a three-position key with contacts arranged either to terminate each branch in a fifty-ohm resistance, or to connect it to the bridge. The three positions of the key are marked "APP," "PHASE," and "STD." In the apparatus position, the standard attenuator branch is terminated in a fifty-ohm resistance, and the apparatus branch is connected to the bridge; while in the standard position, the apparatus branch is terminated in a fifty-ohm resistance and the attenuator branch is connected to the bridge. In the phase position both branches are connected to the bridge.

Before making a phase measurement, it is necessary to make the output potentials of the two branch circuits equal in magnitude. This is done as follows: with the key on "APP" position a deflection is obtained on the detector indicating meter; and then throwing the key to "STD" the standard attenuator is adjusted until the same deflection is obtained. With this adjustment made, the key is thrown to "PHASE," which connects the voltage from the two branches, now equal to the four corners of the bridge.

Under these conditions, the voltage across the phase-measuring attenuator is equal to half the vector sum of the potentials of the two branches. In the apparatus branch, however, there

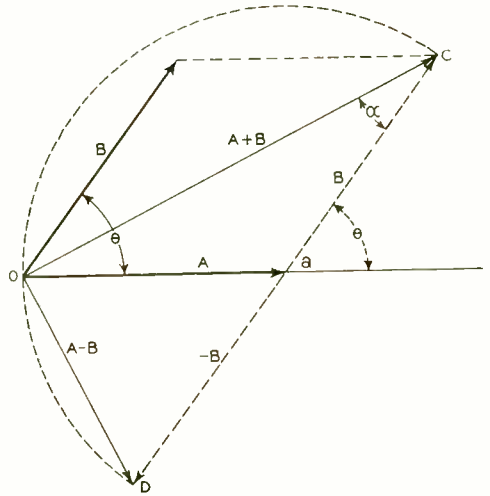


Fig. 2—Vector diagram illustrating the "sum-difference" method of phase-shift measurements

is a reversing switch that permits the potential of that branch to be reversed, or shifted, one hundred and eighty degrees in phase.

If the potential of the standard branch is called  $2A$ , and that of the apparatus branch  $2B$ , the potential across the phase-measuring attenuator

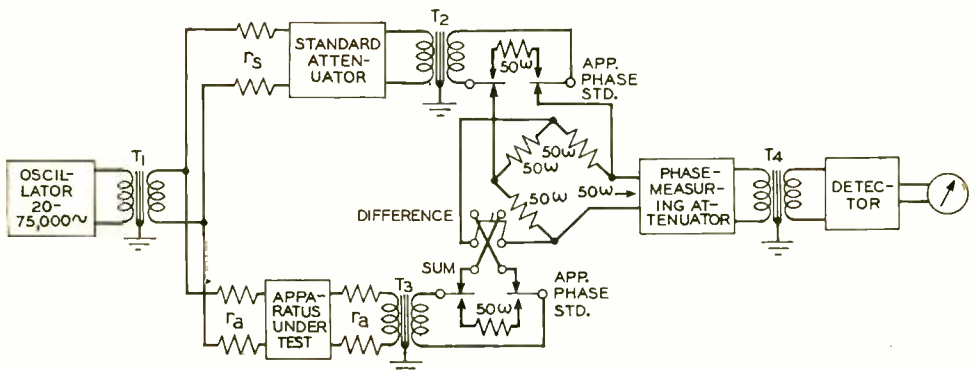


Fig. 1—Simplified schematic of the phase-shift measuring circuit

ator will be  $(A+B)$  with the reversing switch in one position, and  $(A-B)$  with it in the other. With the key of the measuring set on "PHASE," a reading on the detector meter can be obtained for both positions of the reversing switch—that is corresponding to  $(A+B)$  and to  $(A-B)$ . Moreover, the former reading may be made equal to the latter by inserting loss by means of the phase-measuring attenuator. By definition the loss in db inserted to make  $(A+B)$  equal to  $(A-B)$ , which may be called  $L$ , is equal to  $20 \log (A+B)/(A-B)$ .

A vector diagram of these various potentials is shown in Figure 2, where the two vectors  $A$  and  $B$  are equal in magnitude but differ in phase by an angle  $\theta$ . Vectors  $(A+B)$  and  $(A-B)$  form two sides of the triangle  $ocd$ , which is obviously a right-angle triangle since it is inscribed in a semi-circle with diameter  $cd$ , center at  $\alpha$ , and radius equal to  $A$ , which is equal to  $B$ . The ratio  $(A+B)/(A-B)$  is thus equal to  $\cot \alpha$ . This angle  $\alpha$ , however, is equal to  $\theta/2$  since the diagonal of a rhombus bisects the angles at the vertices.  $\cot \theta/2$  may thus be substituted for  $(A+B)/(A-B)$  in the above equation for loss, which, by this substitution, becomes  $L = 20 \log \cot \theta/2$ , or in exponential form this equals  $10^{\frac{L}{20}} = \cot \theta/2$ .

This latter equation is readily converted to the form  $\theta = 2 \cot^{-1} 10^{\frac{L}{20}}$  which gives the phase-shift angle of the apparatus under test as a function of the loss which had to be in-

serted in the phase-measuring attenuator to make  $(A+B)$  equal to  $(A-B)$  in magnitude. A table is used to obtain the phase shift,  $\theta$ , directly from the loss in db that is read on the attenuator.

Since this measuring procedure gives the phase shift of the test apparatus in relation to that of the standard attenuator, any phase shift of any setting of the attenuator must be less than the limits of accuracy of the circuit. This requirement, in conjunction with the necessity for having negligible frequency errors for insertion loss, made it necessary to use a precision attenuator of the type already described in the RECORD.\* Moreover, two attenuators had to be provided to permit measurements of both balanced and unbalanced networks. Both of these attenuators are mounted as part of the measuring apparatus; and the one desired is selected by inserting plug-type terminating resistances—marked  $R_s$  on the diagram—in jacks connected to the

\*RECORD, April, 1937, p. 249.

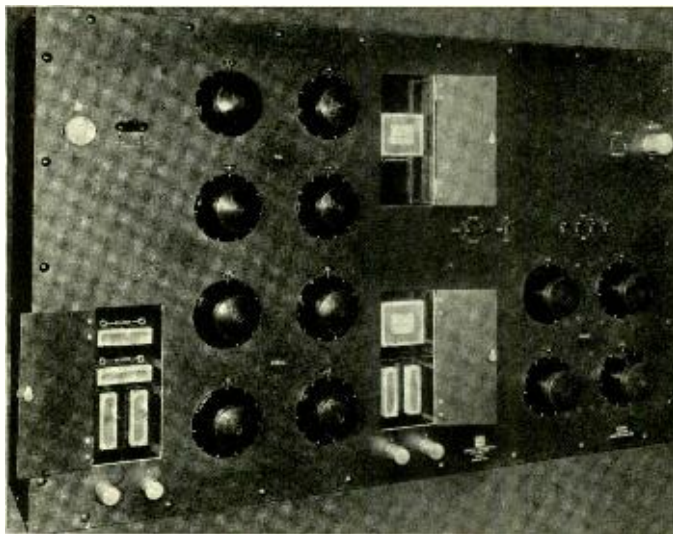


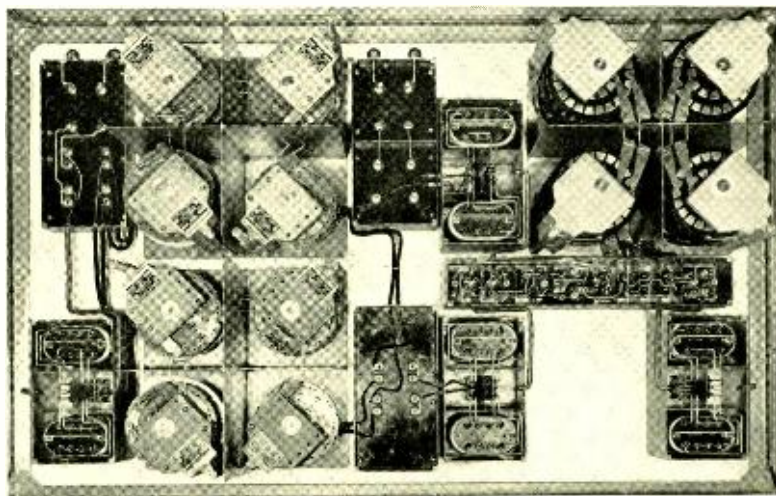
Fig. 3—The measuring panel is arranged to mount vertically to make it easier to reach and read the various dials

desired attenuator. These resistances are used to equalize the two branches, and a similar set, marked  $R_2$ , is used in the apparatus branch to match the apparatus under test.

All parts of the circuit except the oscillator and detector are assembled on a panel arranged to be mounted vertically on a bench, instead of horizontally as has been the more usual custom in the past. This panel is shown in Figure 3. The plug-type terminating networks are shown in the two lower doorways, and the two standard attenuators—one for balanced and one for unbalanced measurements—are controlled by two sets of four dials at the left center. Dials for the phase-measuring attenuator are at the lower right. The range of each of the three attenuators is provided by one dial with five ten-db steps, and three decades with steps of 1, 0.1, and 0.01 db respectively. Four terminals for connecting to the apparatus under test are provided at the bottom of the panel as shown.

For some measurements the potentials at the output of the measuring set are as much as 145 db below the oscillator output, and they must be detected to a precision of 1 db. To obtain this order of gain and sensitivity, a heterodyne type of detector circuit is employed, since it permits the resistance and tube noise to be reduced by using a narrow transmission band. Mechanical filters with a band width not greater than five cycles are incorporated in the detector to help in eliminating noise.

The appearance of the measuring circuit with its auxiliary units, as set up for a test, is shown in the photograph at the head of this article. Insertion phase shift of 600-ohm networks with an insertion loss of not over 30 db can be measured with a precision of  $\pm 10$  minutes over the frequency range from 20 to 75,000 cycles. Networks with higher insertion losses, or with terminating impedances greater than 600 ohms, can be measured with little less accuracy.



*Fig. 4—Rear view of insertion phase-shift measuring apparatus*



# A Recording System for Transmission Measurements

By P. F. JONES  
*General Transmission Design*

THE making of transmission measurements on telephone circuits has been carried on for a number of years with manually operated devices, the latest of which are equipped with meters calibrated directly in decibels. For the single-frequency measurements commonly used in routine maintenance testing, a manual device is quite satisfactory.

When transmission measurements on a circuit or a telephone repeater are to be made at a large number of frequencies as is common during development studies, an automatic recording system will save a large amount of time as it plots the transmission-frequency characteristic directly in much less time than individual measurements could be made.

Several instruments of this kind are now being used on the open-wire carrier and cable carrier investigations, and on the coaxial cable development. Their essential elements are shown in Figure 1. At one end of the circuit is an adjustable-frequency oscillator which generates testing power, a send-

ing panel for supplying this power to the circuit and adjusting it to the proper value, and a synchronous motor for varying the oscillator frequency. At the other end is a receiving panel which amplifies the testing power as received and converts it to direct current which causes the pointer of the recording meter to move. The meter is calibrated to record the transmission efficiency of the circuit directly in decibels. The heavily outlined parts are those used for recording work only; the others are already in use in the field for manual transmission measurements.

The general operation is as follows: Constant testing power is supplied to one end of the circuit by the adjustable-frequency oscillator, the frequency being varied continuously from one end of the range to the other by slowly turning the frequency-control dial with the synchronous motor. Meanwhile the meter at the other end of the circuit is making a record of the received power on a strip of paper, which is moved steadily by another

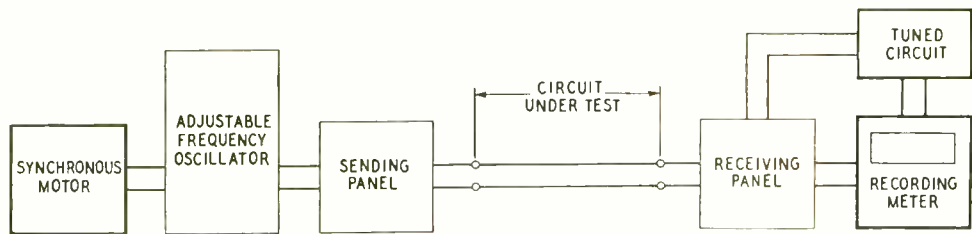
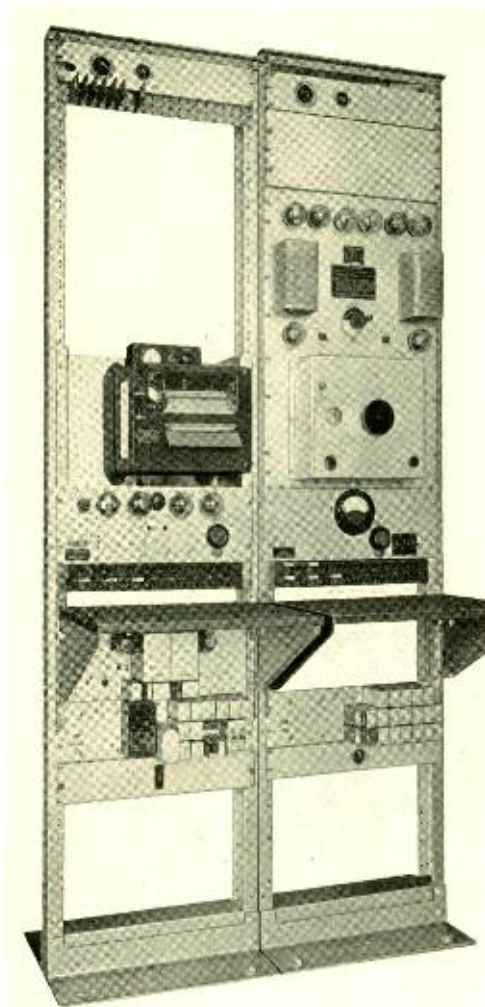


Fig. 1—Schematic arrangement of recording system



*Fig. 2—A laboratory installation of the transmission measuring system*

synchronous motor. The resulting curve is a graph of the variation of the transmission efficiency of the circuit with respect to frequency.

If it is desired to obtain a record of transmission efficiency with respect to time, the same arrangement is used without the motor at the sending end, the oscillator frequency being fixed. The recording meter will then draw a line showing how the received power, and therefore the loss introduced by the circuit, changes with respect to

time. If it is desired to record noise on the circuit instead of transmission loss the oscillator is disconnected from the circuit and the amplification at the receiving end increased until the very small noise currents are sufficient to cause readings on the meter. If the receiving apparatus is connected across a working telephone circuit it will serve as a recording speech-volume indicator.

The oscillator, amplifier and other parts of the system have great stability and when left in continuous operation will remain in adjustment over long periods so that they may be used in the same manner as an ordinary voltmeter.

A complete installation of the recording system is mounted for convenience of operation on two bays as shown in Figure 2. The receiving equipment is on the left-hand bay and the sending equipment on the right-hand. Directly below the recording meter is the amplifier-rectifier which supplies current to the meter. Below the keyshelf is the equipment comprising the tuned circuit indicated in Figure 1. On the right-hand bay is the motor-driven oscillator for generating testing power and immediately below it is the sending panel for adjusting this power and distributing it to testing terminals. Below the keyshelf is the auxiliary equipment provided for automatic operation.

The recording meter is a new design developed by the Weston Electrical Instrument Corporation in accordance with specifications drawn up by Bell System engineers to meet the special needs of telephone circuit testing. It is extremely fast in operation, the moving system responding to fluctuating currents in about the same manner as the moving system of a fast d-c voltmeter. This high recording speed is made possible by making the



record without actual contact with the paper and, therefore, without friction.

Figure 3 illustrates the general principles of this recorder. Heat-sensitive paper is drawn over a straight bar which is at right angles to the direction of paper movement, the bar being shaped so that only a line of paper is directly below the pointer of the moving system. A fine straight electrically heated wire is placed on the end of the pointer so that as the current through the moving system is varied the hot wire travels at approximately right angles to the line of the exposed paper and only a small spot of the paper is affected by the heat at any instant. With this arrangement the plot obtained has rectangular coordinates, which has been found to be a very desirable feature.

The heat-sensitive paper is a colored paper coated with white wax and be-

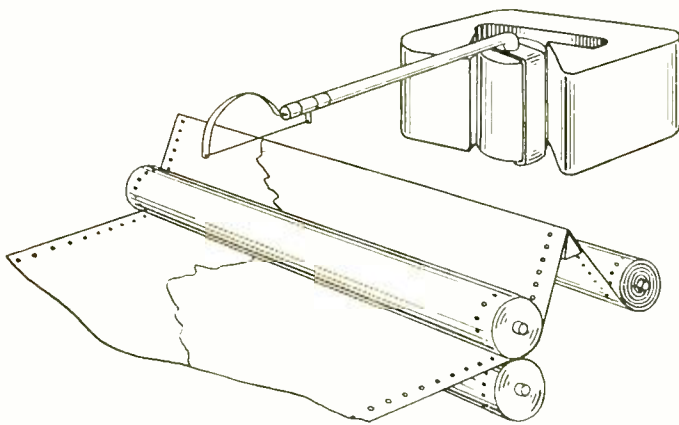


Fig. 3—How the heated wire carried by the pointer makes its trace on the waxed paper

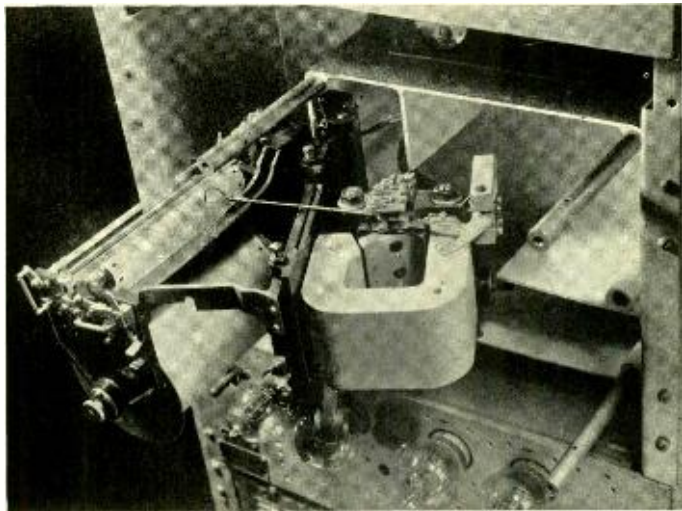


Fig. 4—A close view of the recorder mechanism

fore exposure is nearly pure white. The application of heat causes the wax to melt and be absorbed by the paper, making a distinct colored trace. The rapidity of action is dependent upon the amount of heat and the rate of movement of the heated wire with respect to the paper. The temperature of the wire is regulated to suit conditions; however, the maximum heat used is insufficient to char the paper even when it is not in motion. This method of recording is particularly satisfactory from a maintenance standpoint. A record is made almost the instant the current is turned on and there is no danger of failure of recording when the meter has stood idle for a time.

The reliability is so great that it is not necessary for the attendant making the test to see the recording meter while it is in use. Because of this and the stability of the

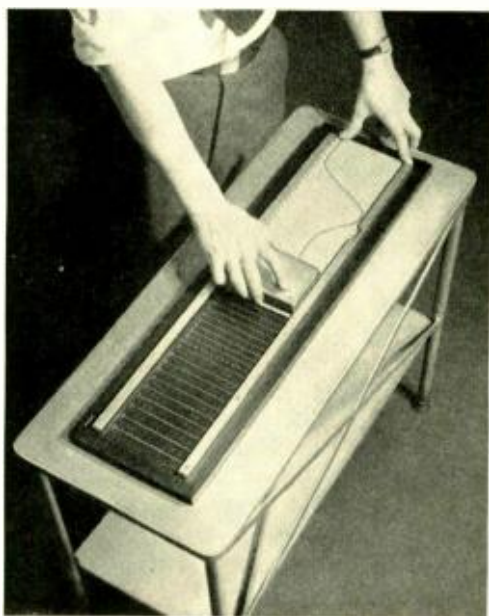


Fig. 5—Impressing the frequency-coördinates on the paper

associated sending and receiving apparatus, it is possible to locate an instrument of this type at some central point in an office and have it used by testers some distance away. For such an installation it is necessary to have auxiliary circuits for enabling any tester to determine if the system is available for use, to indicate when a test has been completed and to enable the recording meter and oscillator to be started from remote points. Either the oscillator or the recording meter can be set in motion by the operation of a key and made to stop automatically when the test has been completed.

The moving system of the meter is similar to the indicating decibel meters used with

new transmission measuring systems.\* Shaping of the pole faces of the permanent magnet and of the iron core around which the moving coil turns, is such that uniform divisions are obtained over a large portion of the scale. The total range of the meter is about 26 db and the scale is divided into 2-db divisions, the first ten of which are approximately equal. To obtain such a wide transmission range with uniform divisions on this type of meter requires an extreme shaping of the pole faces as can be observed from Figure 4. The non-uniform air-gap gives a variable damping and an external damping device is provided to equalize this variation.

The heat-sensitive paper is also sensitive to friction and can be marked by pressure with a small wire, a characteristic which is utilized to make each recorder rule its own db scale as a record is made. Cheap plain unruled paper six inches wide is used and a high accuracy of calibration is obtained by making the ruling devices adjustable. The ruling devices consist of loops of spring wire. While the paper used in the recorder is sensitive to both heat and friction it will stand

\*RECORD, January, 1937, p. 167.

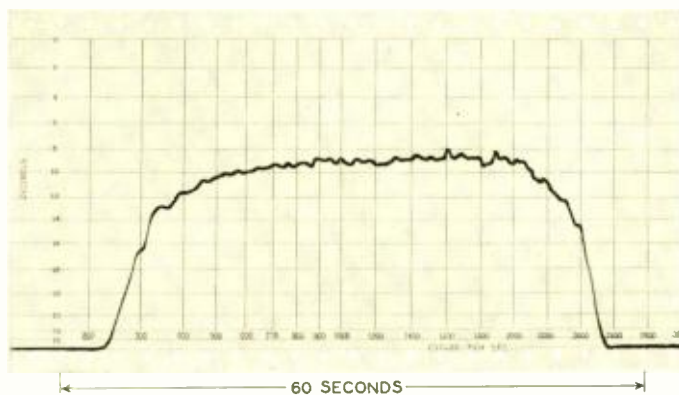


Fig. 6—The "wiggles" in this curve are due to small impedance irregularities in a two-wire circuit

c rable handling without injury.

Two rates of paper movement are used in ordinary testing—ten inches per minute for transmission-frequency measurements where speed is important and five inches per hour for

surface of the paper the wax is removed at points directly over the lines and figures and the color of the paper shows through, making them clearly visible. It is, of course, necessary that the paper be located on the

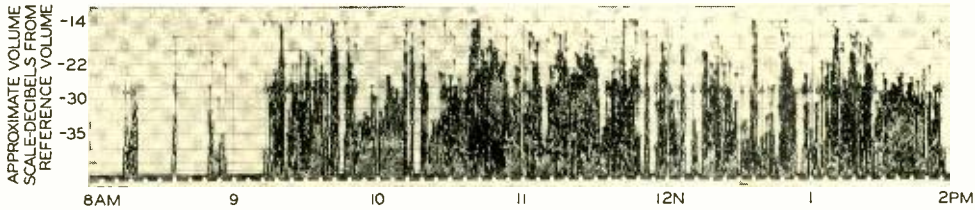


Fig. 7—Speech-volume variations on a working telephone circuit

long-period observations. The paper moving mechanism is made so that each curve can be torn off as soon as made, the paper coming out of a slot in the front of the case shortly after it has passed over the point of recording. The mechanism will accommodate a 400-foot roll of paper, which is sufficient for about 400 transmission-frequency runs or for one month's operation at the slow speed. A new roll of paper can be inserted in a very short time.

As previously stated, the deflection of the meter in db is plotted against frequency for some classes of measurements and against time for others. Since the same meter is used for many types of test it is preferable not to have the paper ruled for either frequency or time. Time reference marks are made on the edge of the paper as it passes through the recorder, the marking device being adjustable so that it may be set correctly when a test is started. Frequency marks are applied after the record has been made by means of the apparatus shown in Figure 5. This is an etched metal plate with raised lines and figures upon which the paper is placed. When the scraper is drawn across the waxed

etched plate so that the frequency marks will be made at the proper points. This is done with the aid of a tuned circuit; when during a test run a particular frequency is received, a magnet is energized whose armature makes a mark on the edge of the paper. Later this mark is aligned with an index mark on the etched plate.

The oscillator of the recording system is of the heterodyne type which uses a single dial for frequency adjustment, the frequency being varied continuously from one end of the range to the other as the dial is turned. When transmission-frequency curves are made a synchronous motor is connected to the dial, turning it at a uniform rate. The time-frequency scale of the oscillator is neither uniform nor logarithmic, but a compromise which gives sufficient space on the record to all parts of the range which are of particular interest. Synchronism of the motors at the two ends of the circuit is effected by driving them from the commercial sixty-cycle system. Many of these systems are now so extensive that both ends of a long telephone circuit will be served by the same power system. Even where this is not the case, the fre-

quency-stability of each system is usually so good that during the time a single record is being made the drift is unimportant.

Three typical curves made by the recording system are shown in Figures 6 to 8. Figure 6 is a transmission-frequency characteristic of a two-wire telephone message circuit. Even the small rapid changes in loss did not escape the record, the curve having been made in about one minute, using a speed of ten inches per minute.

Figure 7 is a record of continuous measurements on a message telephone

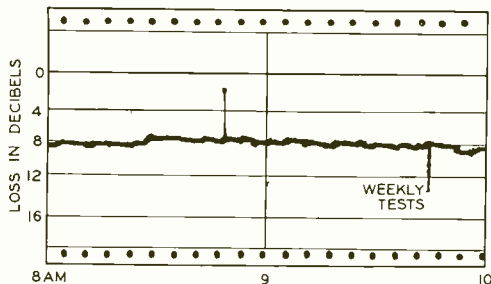


Fig. 8—Continuous 1000-cycle loss measurement during a trouble investigation

circuit. This speech-volume record is of particular interest in showing graphically the variation of load on the circuit during the different periods of the day and also the extreme variations in the volume of different talkers. The recording system was bridged on one end of the circuit so that a difference of several db in volume level between the talkers at the two ends is to be expected.

It will be noted that the width of the mark made by the heated pointer

is much greater in the case of the slow-speed records than in the case of the high-speed records. In the slow-speed records illustrated the points of interest are the peaks which the pointer reaches frequently and the heat is adjusted so that a good record is made of these peaks. The movement of the pointer is so rapid that no trace is made between peaks and the zero line. The exact center of the broad line is directly under the heated wire. This point is clearly seen in the broad trace made by slow-speed records.

Experience with recording transmission measuring systems shows that they are of considerable value in locating intermittent troubles of short duration which are not easy to locate with manual arrangements. Figure 8 is a record of the 1,000-cycle loss of a long four-wire cable circuit which was removed from service for purpose of trouble location. The small jogs in the curve were caused by the normal functioning of the automatic transmission regulators and the large jog at 9:45 A.M. was caused by an attendant making a routine adjustment. The sudden change, occurring at 8:50 A.M., was due to a trouble which momentarily decreased the transmission loss. A trouble condition of this type can be located by connecting transmission recorders at a number of different points along a circuit and making simultaneous records.

Transmission-frequency measurements on circuits and repeaters can be made with this recording system in less than one-tenth the time required with manually operated apparatus.

## Console-Type Speech-Input Equipment

**T**O meet the need for a single compact speech-input unit for small radio stations, a console-type equipment, coded the 23-type, has been developed. This equipment has also found application in the individual studio control rooms of large stations and at radio transmitter locations where studio facilities are desired. Its compact form and ease of installation also make it useful for speech-input purposes at remote pick-up points which are semi-permanent.

The cabinet is low enough to mount on a table without obstructing the view of the operator and thus combines the facilities normally provided by a bay assembly and control turret.

The equipment handles four microphones or transcription programs and one program line at a time. In addition to the regular microphone switching keys, a "talkback" key enables the operator or program director to communicate with the studio through the loudspeaker system. This feature is



*Console-type speech-input equipment being operated by E. L. Owens, who was associated with its development*

particularly desirable during rehearsals or auditions, when the program director is observing a performance from the control room and desires to converse with the artists in the studio.

The complete unit including amplifiers, volume indicator, power supply and switching circuits is assembled on a metal chassis 34 inches long and 14 inches wide. Three covers which protect the equipment also provide shielding between the various parts.

Small vacuum tubes of the commercial receiver type are used in the amplifiers and high-fidelity performance is achieved through the use of stabilized feedback. The maximum net gain from microphone to line is approximately 100 db, which is more than sufficient for modern broadcast microphones under all normal conditions. The equipment is provided with a choice of two input impedances so as to work satisfactorily with Western

Electric dynamic microphones, or with microphones of the velocity type.

The performance characteristics of this equipment meet all of the present and tentatively proposed standards for high-fidelity radio broadcasting. The frequency response of both the microphone and program line channels is uniform within one db from 30 to 10,000 cycles per second. The unweighted noise introduced by the equipment when operated at the maximum gain ordinarily required for Western Electric 630A Microphones is 61 db below the program level. Under the same condition the noise weighted as the ear would hear it is 70 db below the program level. The harmonic distortion at the output of the line amplifier for a level 60 milliwatts is less than one-quarter of one per cent at 5,000 cycles, less than one-third of one per cent at 400 cycles, and less than one per cent at 50 cycles.

---

## Contributors to this Issue

I. V. WILLIAMS received the B.S. degree in electro-chemical engineering from Pennsylvania State College in 1926. He had been employed by The Bell Telephone Company of Pennsylvania during the summer of 1925, and after graduation he was transferred to the Apparatus Development Department of these Laboratories. Mr. Williams has been concerned with various metallic materials and their testing.

AFTER RECEIVING the degree of B.S. from the University of California in 1920, Milton L. Almquist spent one year with the General Electric Company at Schenectady and then joined the Department of Development and Research of the American Telephone and Telegraph Company. There he engaged in the develop-

ment of toll equipment, first with radio systems and later with toll signaling and carrier developments. In 1932 he was placed in charge of a group handling toll maintenance and test board development, which, with the merging of the D. and R. and the Laboratories in the spring of 1934, became part of the Systems Development Department. Since 1935 he has been in the Transmission Development Department where he has been engaged in the design and development of carrier systems.

UPON GRADUATING from Cornell University with the degree of M.E., specializing in Electrical Engineering, E. C. Wegman joined the Bell System in July, 1910, at the Hawthorne Works of the Western Electric Company. He was first



*I. V. Williams*



*M. L. Almquist*



*E. C. Wegman*

assigned to the student course where he remained for about six months, part of this time being spent in installation work in Chicago and Columbus. In January, 1911, he was transferred to the Engineering Department of the Western Electric Company at Hawthorne, now a part of the Bell Telephone Laboratories, where for several years he was engaged on the development of phantom-type cable circuits suitable for loading. Mr. Wegman has been employed continuously at Hawthorne ever since on cable development problems, one of the most important of which in recent years has been that of pulp insulation.

SOON AFTER the World War ended, P. F. Jones entered the American Telephone and Telegraph Company with a degree from the University of Vermont (B.S. in E.E., 1918) and a commission in the Coast Artillery Corps to his credit. His first assignment was to the study of transmission characteristics of circuits, and during the next few years he measured several hundred standard telephone circuits which he assembled for the purpose. This work led ultimately to the placing of transmission information on circuit drawings.

When those determinations were undertaken, such meas-

urements as were made depended on ear comparisons. The first meter-balance sets were developed by the group of which Mr. Jones was a member; and during the ensuing years he has seen these sets not only displace ear balance devices but extend their use into every part of the telephone plant. Devices are now available for every purpose from the portable meter to be used at the subscriber's telephone to the automatic recorder described in this issue.

G. E. ATKINS joined the Equipment Engineering Department of the Western Electric Company at Hawthorne in 1923 after attending Roanoke College. The following year he transferred to the New England Telephone and Telegraph Company to undertake similar work. He be-



*P. F. Jones*



*G. E. Atkins*



*E. A. Bescherer*



*J. S. Elliott*



*W. Herriott*

came a member of the Inspection Engineering Department of the Laboratories in 1926. At first his efforts were directed to telephone power apparatus and later to motor design. Since 1930 he has been engaged on mechanical design problems in the Commercial Products Department.

E. A. BESCHERER graduated from Purdue University in 1928 with the degree of B.S. in electrical engineering. He at once joined the Technical Staff of the Laboratories, serving in the trial installations group of the Equipment Department. He later served successively in the current development and toll equipment groups. In 1934 he transferred to the Radio Development Department, where he has since been chiefly engaged in the development of aircraft radio equipment.

J. S. ELLIOTT received a B.S. degree from Pennsylvania State College in 1922 and at once joined the technical staff of the Laboratories. With the apparatus development department he was first engaged with routine tests and in making measurements of the electrical constants of apparatus. He then transferred to the condenser design group where he re-

mained until 1927. Following this he engaged in the design of circuits and equipment for measuring the constants of transmission apparatus.

W. HERRIOTT was engaged in astronomical research and worked in aerial photography before he came to the Laboratories. From 1914 to 1917, while an undergraduate, he assisted at the Alleghany Observatory. The following three years he spent with the Eastman Kodak Company on problems in astronomical and aerial photography. The next five years he worked with the Bausch and Lomb Optical Company on optical apparatus and the succeeding three years found him with the Fairchild Aerial Camera Corporation where he had charge of their Scientific Department. In 1928 he joined the Electrical Research Products, Inc., to work on sound pictures. These studies were continued at the Laboratories until 1936 when he transferred to the Materials Group of the Electro-mechanical Development Department to work on various optical and photographic problems including high-speed motion-picture photography.