

# WELL LABORATORIES RECORD

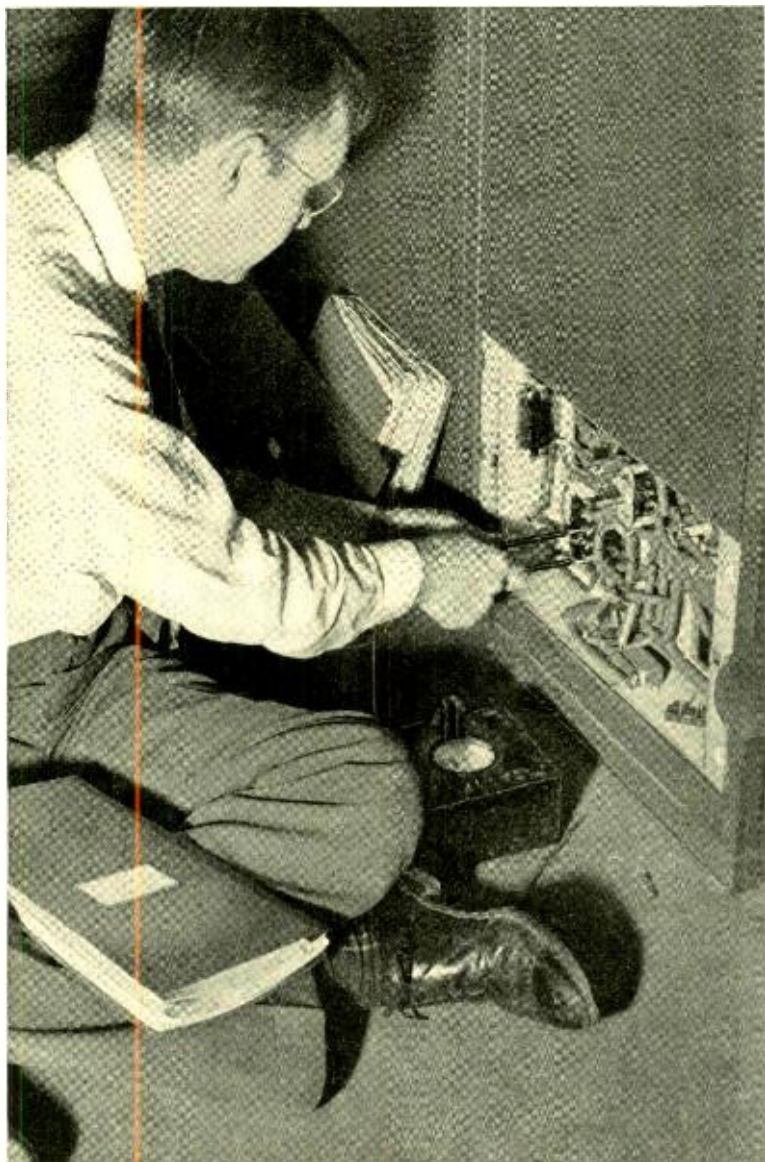

FEBRUARY

1942

VOLUME XX

NUMBER VI

*Testing a receiver of the  
radio telephone link between  
Norfolk and Cape Charles*

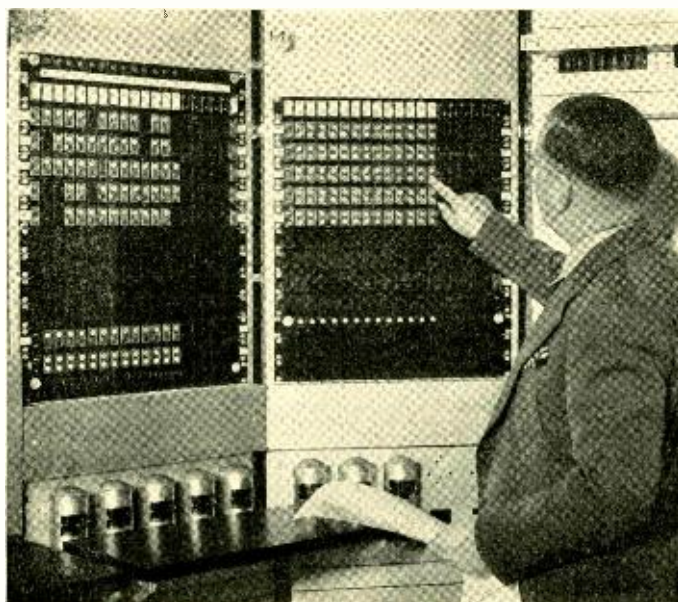

## Program Switching and Pre-selection

By P. B. MURPHY  
*Switching Development*

SINCE the days when the only thing in the way of a broadcast network was a single telephone line connecting a microphone to a radio transmitter, the Bell System has steadily improved and extended the circuits and added many new facilities to take care of the growing needs of the radio broadcasting industry. With the rapid expansion of the program networks, provisions for rearranging circuits at switching points have been in particular the subject of almost continuous study and development. As long as the number of switches at any one point was small, the attendant could listen for cues indicating the end of a program, and then operate the proper keys or change connections with patching cords. As the number of possible switches in-

creased, however, the probability of errors increased, and various switching equipments were provided to meet the requirements at particular points. During this period the situation was being studied to determine whether a switching system could be designed that would take care of all existing as well as probable future requirements. As a result a system has been designed, and tested both in the laboratory and in commercial installations, that seems to meet all existing requirements, and to be capable of expansion without fundamental change to meet all the future switching requirements that can be foreseen at the present time.

At any major switching point there will be a number of program circuits. Some of these will be lines to local

broadcasting stations, and the others will be program trunks running over the various toll routes in all directions. For each program, certain of these lines and trunks will be connected together as part of some "network." There are a number of such networks; some of them cover the entire country, and others may be less extensive in scope. At any one time all stations associated with any one network are broadcasting the same program, but the network is not a permanent structure. For the next program it may include a different set of stations. The basic problem of program switching thus consists in the rearrangements for each program of all trunks and lines at each switching point into the desired network. For purposes of visualization, the situation at one point could be represented by a rectangular lattice with each vertical line representing a program line or trunk, and each horizontal line representing a particular network, which for each program will connect certain of the lines together.

Such a lattice serving the National Broadcasting Company at the toll office in Omaha, where the first installation of the new switching unit was made, is shown on Figure 1. Each intersection of vertical and horizontal lines represents a point where switching may be done, but for this particular installation, only those intersections included in a small rectangle are equipped with a switching circuit.

The actual switching accomplished

at each intersection is indicated in greater detail in Figure 2. The horizontal grouping circuits are called "multiples." Several types have been used in the past, but the one shown is that using "G" type bridges and 14C amplifiers. Each line in these multiples is arranged on a reversible basis with respect to the amplifier bridge circuit so that it may be connected to the input of the amplifier and serve as a program source, or to one of the bridge legs to receive a program from another point. This control of direction of transmission has already been described,\* and is entirely independent of the changes made in the connection of lines to networks at the various switching points.

Since one of the objectives of this development was to reduce operating error by relieving the attendant of the

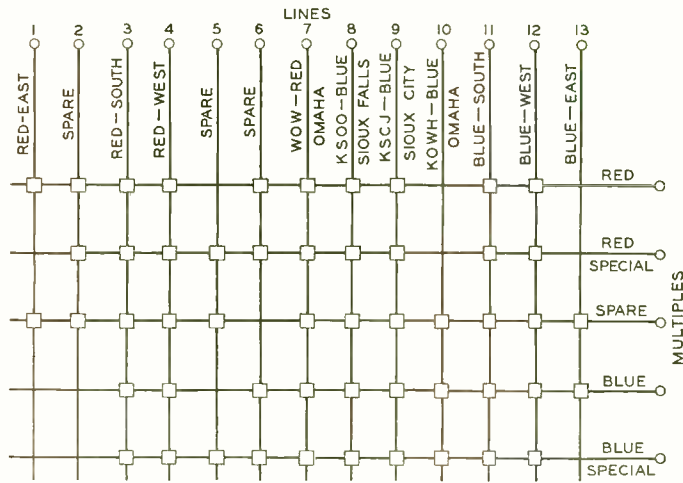

Fig. 1.—Arrangement of lines and multiples for the National Broadcasting Company at Omaha

necessity of performing a large number of operations in the few seconds between programs, it was desirable to secure some form of pre-selection. It should be possible, in other words, to

\*RECORD, April, 1941, page 234.

set up the connections desired for each program period during the preceding period, when there would be plenty of time to recheck carefully all the pre-selections made so as to avoid the

which it is free to move, although normally held in the forward position by springs. When it is pressed in, a spring contact is closed, and this contact is used to set up the pre-selection

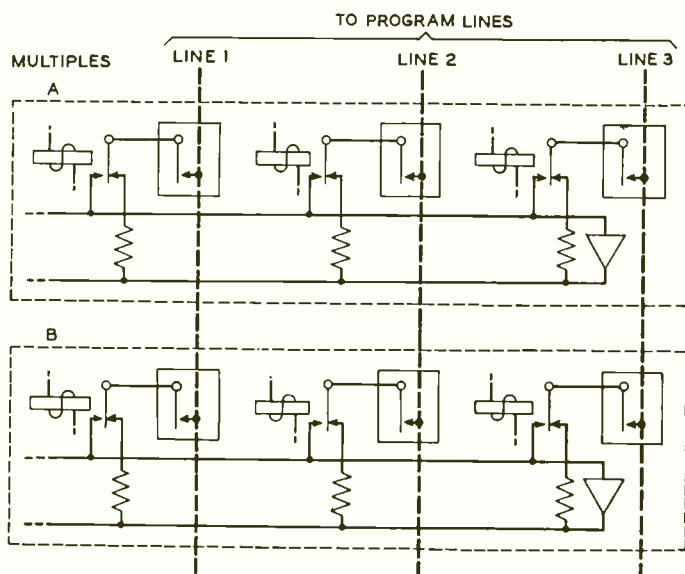

Fig. 2—Simplified schematic of multiplying circuit

possibility of error. These pre-selection switches, of course, would not actually reconnect the program circuits, but would merely set up paths through relays so that the switch could be made at the desired moment by a simple push-button operation. The method adopted employs a pre-selection key at the positions corresponding to the small rectangles of Figures 1 and 2 with white and red lamps associated with each key; a white light would indicate that a pre-selection had been made, and a red light, that the actual switch had been consummated.

To serve as this pre-selection key, the unit shown in Figure 3 was developed. It is called the 36A control unit, and its front section houses a white and a red lamp. This front block is mounted between guides, within

path. These control units are mounted on a panel in the form of a rectangular lattice like Figure 1—each vertical column corresponding to a program circuit and each horizontal row to a multiple. The panel used by the American Telephone and Telegraph Company at the Omaha toll office is shown at the left of the photograph at the head of this article.

Associated with each of these units is a circuit shown in simplified form in Figure 4.

When the control unit is pressed in, contact c is closed. This operates relay A, lights the white lamp, and establishes a path to the L relay, which will make the actual switch when the proper time comes. There are a number of other relays associated with this circuit, but their arrangement is not essential to an understanding of the main operating procedure.

At some place in the office where these control panels are located are monitors, who listen to the various programs to make sure that the circuits are all operating correctly. There is one of these monitors for each network, and since it is the monitors that hear the cues indicating the ends of the programs, it is desirable to have them operate the keys that make the various switching changes. Each mon-

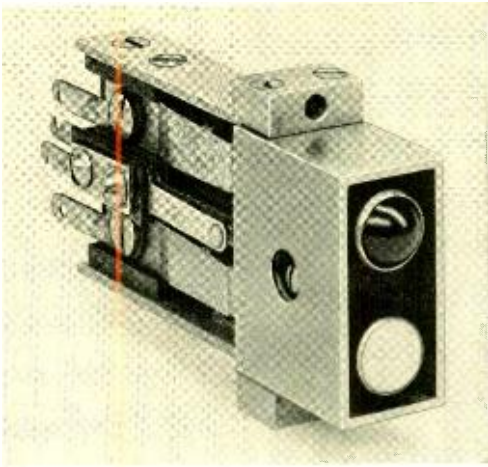

Fig. 3—Key unit developed for the pre-selection of program switches

itor has a cue key, and when he operates this key, all the switching changes pertaining to his network that have been set up on the pre-selection panel will be made. One of the Omaha monitoring positions is shown in Figure 5.

The end of a program does not necessarily mean that switching changes are to be made, however. Frequently a particular set of stations may be grouped together for a number of periods. Also, all the programs may not end at exactly the same time, and the complex arrangements between program circuits and networks frequently require that certain programs have preference with respect to certain lines. A certain line associated with multiple A, for example, may be scheduled to be changed to multiple B at the end of the period. Three possible preferences may exist, however. It may be desired to hold this line associated with the A network until its program has ended, even though the new

program on the B network starts before this. As a second possibility, it may be desired to change the line to multiple B as soon as the new program begins even though the program on the A multiple has not ended. The third possibility is a combination of both of these; it may be desired to hold the line associated with the A network at least until its program has ended, and then to connect it to the B network, but not until the new program on the B network is ready to begin. To permit control of such situations, which are often very important at the large switching points, a "cue" control panel is also provided. This panel likewise uses the 36A control units, and in appearance is very similar to the pre-selection panel. The cue panel at Omaha is shown at the right in the photograph at the head of this article.

On the cue panel there is a 36A control unit for each intersection of line and multiple as on the pre-selection panel, but these control units are equipped with white lamps only. After the attendant has set up all his pre-selections and carefully checked them with his schedule, he goes to the cue

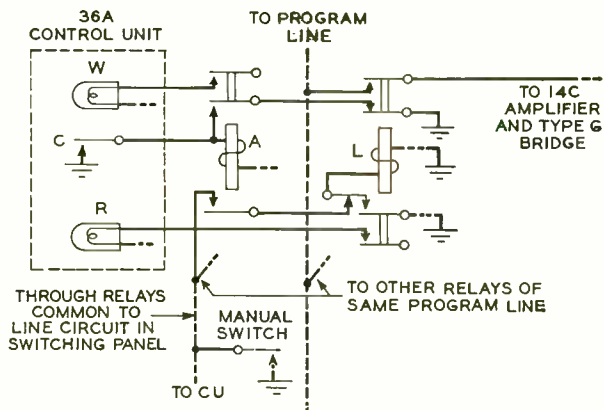

Fig. 4—Simplified schematic of circuit associated with each 36A control unit

panel and presses the control units there for all the controlling cues. Assume, for example, that program line 1, now associated with multiple A, is to be connected to multiple B at the end of the period, but that the con-



*Fig. 5—Monitoring is commonly done at the amplifier bays, and in this position, at the Omaha toll office, the cue lamps and keys are in the jack multiple*

nection is to be held on multiple A until that program is completed regardless of whether the new program on multiple B has begun or not. On the pre-selection panel the control unit at the intersection of line 1 and multiple B has been operated, but on the cue panel the attendant will press the cue lamp at the intersection of line 1 and multiple A. This operation will set up circuits that will not change the connection of line 1 until the

program on multiple A is completed.

The circuits associated with the cue panel are shown in simplified form in Figure 6. The pressing of a control unit operates an A relay and lights a white lamp as on the pre-selection panel. After all the required control units have been operated, the attendant will compare the lighted lamps with his instruction sheet to make sure everything is correct, but will do nothing further until shortly before the end of the program period. He then presses a master cue key. This operates the N relay which lights a red master cue lamp at the cue panel and white cue lamps at the monitor positions of multiples that have white lamps lighted at the cue panel. It also operates a C relay for each line that has a lighted white lamp on the cue panel. Relay C, in turn, operates relay D, thus establishing a path to the L relays of the pre-selection circuit over which the switch will ultimately be made, and holds itself operated through another winding.

When a monitor hears a cue indicating the end of a program period, commonly the station letters, he operates his cue key if his white "cue ready" lamp is lighted. This lights the red "cue sent" lamp at the monitor's position, and the G relay associated with his multiple on the cue panel. The operation of G releases all operated A relays of that multiple, and these, in turn, release their associated C relays. Since the D relays of all lines involved in the switch were operated by the previous operation of their associated C relays and were locked in through their own contacts, the release of the C relays closes ground to the CV leads of the associated line circuits of the pre-selection panel. These ground connections operate a group of relays not shown on Figure 4, and

these first release all operated L relays associated with their lines, and then—either immediately or after a three-second interval, depending on the circuits involved—operate all L relays associated with pre-selected A relays. The operation of L releases the A relay, extinguishes its associated white lamps, and then lights the red lamp on the pre-selection panel.

To illustrate the usefulness of the cue panel, consider the situation where line 1, connected to multiple A, is to be transferred to multiple B for the next program but the transfer is not to be made until the program on multiple A is completed. On the pre-selection panel the control unit at the intersection of line 1 and multiple B will be operated, and on the cue panel the control unit at the intersection of line 1 and multiple A. When the at-

tendant operates his master cue key, the c relay of line 1 (Figure 6) will be operated through the contacts of the A cue relay of line 1 for multiple A, which has been operated through the cue control unit. When the monitor on B multiple hears the cue indicating the end of his program, assuming this finishes before the program on the A multiple, he operates his cue key. This will have no effect on any of the relays of line 1 because the cue relay at the intersection of line 1 and multiple B is not operated. When the monitor of multiple A operates his cue key at the end of his program, the c relay of line 1 releases, and line 1 will be switched to multiple B as pre-selected.

Had it been desired to hold line 1 with network A until that program had ended, and then not connect it to network B until the new program on

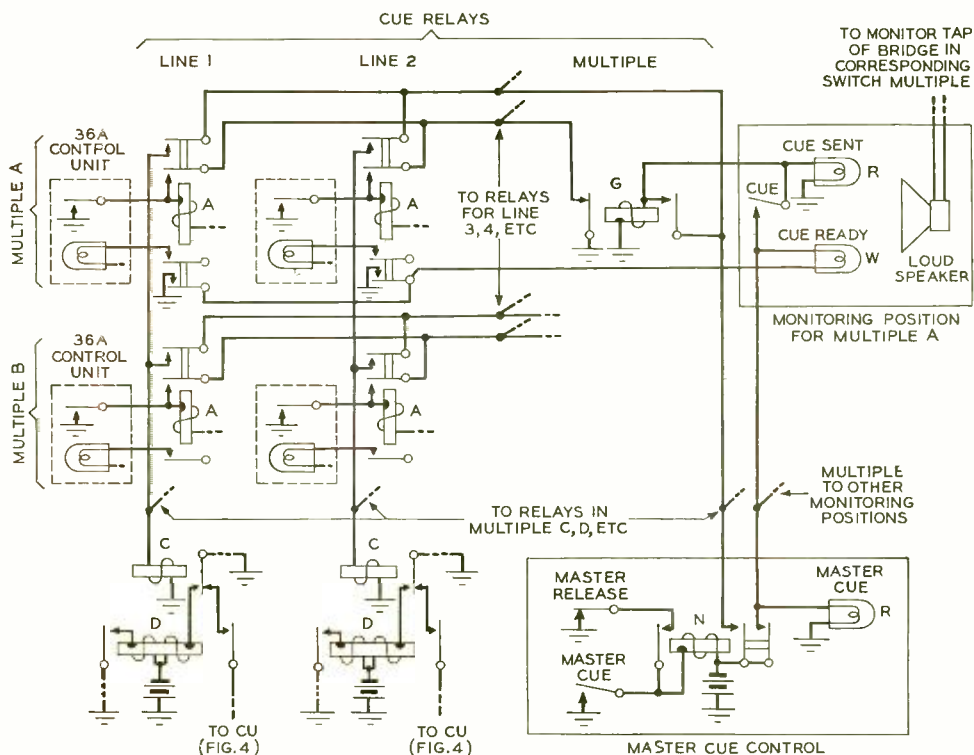

Fig. 6—Simplified schematic of circuits associated with the cue and monitor panels

that network was ready to begin, a double cue would have been set up. The cue control units at the intersections of line 1 and networks A and B would both have been operated. This would prevent the actual switching of the lines until the desired conditions had been fulfilled, because the c relay of line 1 will not release until the cue keys for both multiples A and B have been operated.

With this equipment the proper pre-selections and cues may be set up and checked at leisure during the program period. Shortly before the end of the period the attendant operates his master cue key, which lights white lamps at all monitor positions that are involved in program switches. As the monitors with lighted cue-ready lamps hear the cue indicating the ends of their programs, they operate their cue keys. The white lights on the cue panel go out as the moni-

tors for the various multiples operate their cue keys, and thus indicate to the attendant that the cues have been attended to. The white lights on the pre-selection panel go out, and the red lamps light, as the actual line switch is made following the operation of a monitor's cue key for the multiple in which the cue lamp was lighted.

The system is very flexible in that the number of lines or multiples may be readily increased without interfering with existing wiring. When all positions are filled in one panel, additional panels may be added either above or at one side of it. Since all operations are performed by momentary contact closures, the circuit is readily adaptable to remote control, and certain installations of this type have been made. Experience in the field indicates that the design objectives desired for this new equipment have been very satisfactorily met.

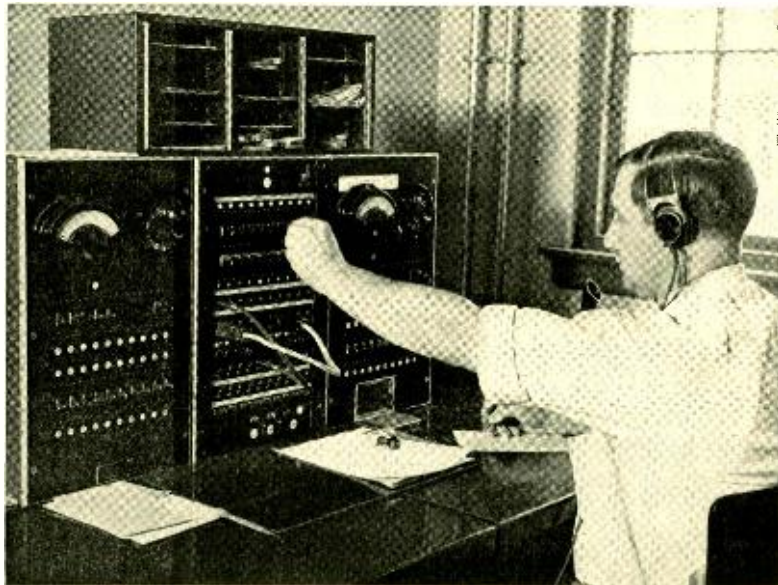

*No. 3 local test cabinet designed for testing subscribers' lines, trunks and similar circuits in small dial or manual offices, or as an adjunct to other testing equipment in the larger offices*





## Mobilization of Science for War Effort

---

**T**HE research set-up which has been created for the war emergency was outlined by F. B. Jewett, president of the National Academy of Sciences, in an address before the winter convention of the Institute of Radio Engineers. Throughout the country, about six hundred military projects have been approved, and for the most part contracted out to universities and industrial laboratories, while the number of contracting institutions is over 100. Working on such projects under contracts placed through the Western Electric Company are about 600 members of Bell Telephone Laboratories' technical staff.

"Of all the branches of applied science," Dr. Jewett stated, "that which has to do with the rapid transmission of intelligence is perhaps most vital to the successful use of modern fighting instrumentalities. Rapid movement of troops and supplies over far-flung lines of action on sea and land and in the air are possible only on the basis of very effective systems of radio communication. In fact, more and more are means of communication assuming the function of a unifying influence which pervades the other arms of the military organization. They coordinate the movement of naval and aerial fleets. They enable infantry, tank columns, and formations of planes to operate as a single effective unit. They shrink a 2000-mile battlefield to the compass of a single sector."

"Basically," Dr. Jewett said, "every

military problem hinges on the rapid and exact location of an enemy objective and on transmitting and utilizing the knowledge acquired. This may be for the guidance of a commanding officer; the accurate pointing, fuse setting and firing of a gun; the release of an aerial bomb, or any one of a hundred similar things. Every single physical phenomenon which can be employed must be examined. Because modern science has changed the conditions of warfare from a slow-moving affair in localized areas to one of great rapidity over incredible distances of land, sea and air, it is imperative that those phenomena which have given us radio be developed and utilized to the full.

"While the initial problem is one of intense research and development, each step forward involves great numbers of skilled technicians in design, manufacture, maintenance and operation of new implements. It seems clear that the demand for men trained in our art is bound to be enormous, not alone in the laboratory but in the service of supply and in the combat forces as well."

Dr. Jewett then briefly traced the history of the organization of civilian science to aid in the solution of military problems. As long ago as 1863, the National Academy of Sciences was created by Congress to study scientific or technical questions submitted to it by any of the Government departments. In 1916 President Wilson created the National Research Council. This was and is a subsidiary of

the Academy, and both agencies have this characteristic—they are not set up to take the initiative, but must await the assignment of problems before they can go seriously to work.

In 1915, however, another agency of a different type was established by Congress. This was the National Advisory Committee for Aeronautics, commonly known as the NACA. The law which created the NACA provides that it shall “supervise and direct scientific study of the problems of flight, with a view to their practical solution,” and also “direct and conduct research and experiment in aeronautics.” The Committee includes both civilian and military members, and its work, as Dr. Jewett expressed it, “has given ample testimony to the fruitfulness of coöperation between military and civilian groups.”

The new National Defense Research Committee was therefore modeled along similar lines. Established by Executive Order of President Roosevelt in June, 1940, the NDRC is composed in part of civilian scientists and in part of Army and Navy representatives. The President’s Order “established the Committee as a division under the Office for Emergency Management and confers upon them power to take the initiative in many scientific matters which they believe to have military significance. It also directed the Committee to develop broad and coördinated plans for the conduct of scientific research in the defense program, in collaboration with the War and Navy Departments; to review existing research programs formulated by these Departments, as well as other agencies of the Government; and advise them with respect to the relationship of their proposed activities to the total research program. Moreover, and this

is especially important, the Order directs them to initiate and support scientific research on the mechanisms and devices of warfare with the object of improving present ones, and creating new ones.”

During its first year the NDRC authorized research projects which totaled about 10 millions. It was then granted another ten millions by Congress and this has recently been increased by several millions more. The Committee is divided into four divisions, and each division into numerous sections. Each section chairman selects members and consultants who are officially appointed after clearance by the Army and Navy Intelligence and the FBI.

“Neither the five civilian members of the NDRC itself nor any of the section chairmen, members or consultants are paid from public funds,” Dr. Jewett said. “Without exception, they are loaned to the Government by their employing organizations and frequently the loan is complete, the work being so voluminous and detailed as to require a man’s full time. Thus, when I tell you that about 500 of the leading scientists of the country are encompassed in the NDRC organization, you will see that the Federal Government and even the forgotten taxpayer are getting a lot of valuable consulting talent free of charge.”

Members and consultants formulate the projects to be undertaken and then arrange with various scientific institutions to carry on the work. “It is this last step which brings in the need for considerable sums of money. For instance, a project assigned to a particular university or industrial laboratory may require the full time of several of its faculty together with that of numerous younger men hired specifically for the work in hand.”

The total value of the projects thus far determined upon is upwards of 20 millions, and between four and five thousand scientists and engineers are at work on them, in addition to perhaps an equal number of laboratory assistants and technicians.

Referring to the 600 members of the Bell Laboratories technical staff now engaged full-time on defense projects, Dr. Jewett added, "I am excluding those who by circumstances arising out of the defense program have been forced to devote themselves to such problems as the finding of substitute materials and the development and engineering of emergency telephone projects."

Looking to the future, Dr. Jewett said, "The stages of the program to follow will doubtless involve a broader survey of the situation to find locations where new problems can be lodged with a minimum of interference to essential defense work and teaching now in progress. In this survey a guiding principle will be to utilize men and facilities on the spot whenever possible, thus preserving the going value of groups who are accustomed to working together. In the face of crises, the human tendency is usually to do the reverse, it being so easy for central agencies to ignore established but not well-known organizations, and attempt to cope with an emergency by calling workers from right and left to some new location. As a matter of fact, this tendency was beginning to make an appearance even as long as two years ago when the fundamental plan of NDRC was under discussion. Had the tide then setting in been allowed to run on for

some months unimpeded, the result would inevitably have been a literal army of uprooted scientists in Washington and other central points, sitting around idly waiting for vast amounts of research equipment which had been placed on order, but was not much nearer materialization than that, to be installed in hastily constructed laboratories. This would have been the easy and disastrous way. Fortunately the creation of the NDRC came in time to stem such a tide.

"Another present problem is one which by its existence supplies evidence that real progress has already been made. It has to do with shortening the time gap between proven laboratory research results and the stage where mass production can be undertaken. Some of the laboratory results already achieved hold such promise that every day which intervenes before their widespread utilization becomes a serious matter. Obviously the problems to be met here cover a wide range of equipment and materials, and since they involve large-scale manufacture, the whole plan must be carefully worked out with other official agencies, particularly the Office of Production Management and the armed services. I am sure, however, that we are prepared to meet and solve these problems, and rather than be concerned with the difficulty of making progress along this avenue, I think all who are guiding the work of the NDRC would exclaim to the ranks of scientists and technicians, 'Bring on your results, the more the better, and we will guarantee them a speedy passage to the firing line!'"

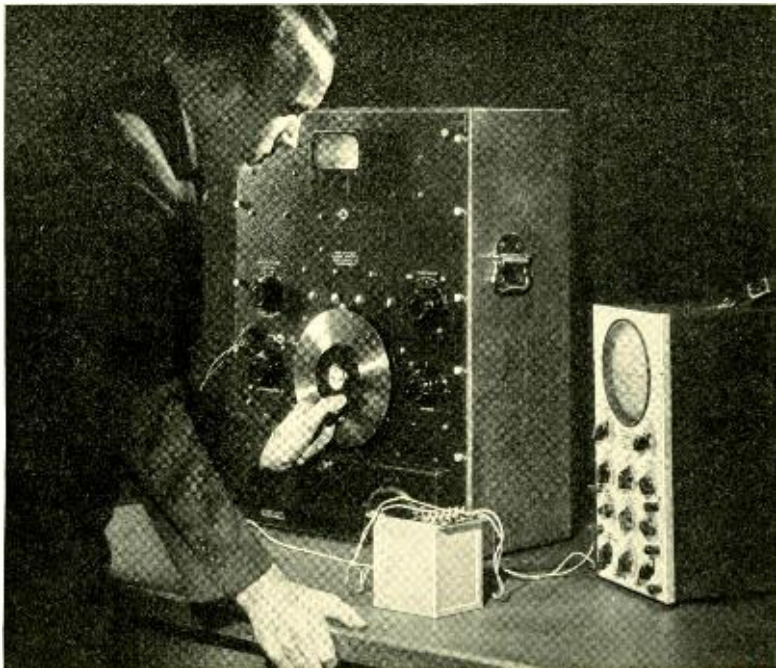

## Generator for Dial and Busy Tones

A. B. HAINES

*Transmission Apparatus Development*

FAMILIAR tones to telephone users are the dial and the busy signals of dial exchanges. In large offices these are furnished by rotating machines but in small ones they are customarily produced by vibrating relays. As an improvement, the 101A frequency generator has recently been developed primarily for the small offices. It has no moving parts or vacuum tubes and hence completely eliminates the maintenance, adjustment and replacement expense of vibrating relay equipment. It operates directly from a commercial sixty-cycle power supply and generates signaling current by using the non-linear characteristic of a saturated magnetic core to produce

harmonics of the power-line frequency. This method was suggested by L. R. Wrathall.

The input circuit, Figure 1, has a condenser  $c_1$  in series with the primary winding of a saturable transformer  $T_1$  and both are across the sixty-cycle supply. A non-sinusoidal voltage is obtained across the primary winding because its inductance characteristic, with changing current, is non-linear. This voltage induces a non-sinusoidal current of high peak value in the secondary circuit with its condenser  $c_2$  and varistor  $rv_1$ . Odd harmonics of the sixty-cycle fundamental are present in relatively large quantities in this secondary current. They are doubled in frequency and

thus converted into even harmonics by the full-wave rectifying action of the copper oxide bridge RV1. Transformer T<sub>2</sub> and condenser C<sub>3</sub> form an anti-resonant circuit which picks out the required signaling current. This network is broadly tuned to 600 cycles, which is the tenth harmonic of the input frequency, but adjacent harmonics at 480 and 720 cycles pass into the output circuit in sufficient amounts to produce, for the subscriber's signal, a 120-cycle modulation as shown in the wave form of Figure 2. In quality this output tone compares favorably with that produced by rotating machines in large central offices. Resistance R<sub>1</sub>, Figure 1, protects the input circuit when it is disconnected from the line by discharging the condenser C<sub>1</sub>.

The power rating of the 101A frequency generator is approximately thirty-five milliwatts, which is adequate to serve small dial offices of several hundred lines capacity. For dial tone, the output current is used directly from the frequency generator and it is stepped down to a lower level by transformer T<sub>2</sub> to be interrupted at sixty I.P.M. for busy tone. A d-c

supply is also generated across resistance R<sub>2</sub> for operating an alarm relay. When failure of the sixty-cycle input occurs, this d-c output is cut off, which releases the alarm relay and automatically switches the generator to an emergency sixty-cycle supply or cuts in a standby source of tone.

Standard transformer structures and circuit elements such as condenser, varistor and resistance units

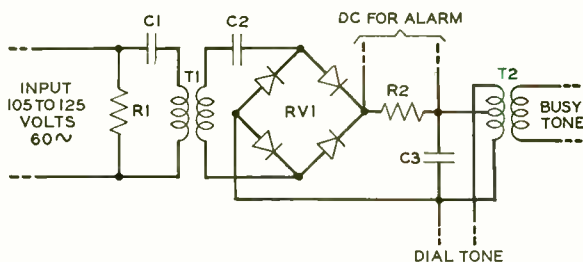

Fig. 1—Input circuit of the generator

are used throughout the design. The generator input is terminated in a rubber-covered cord and plug suitable for connection directly to 115-volt commercial power outlets. Solder-type terminals mounted on a terminal plate are provided so that the output may be wired to associated tone equipment. The apparatus is assembled in a steel transformer case and weighs approximately four pounds.

The generator operates satisfactorily without taps or adjustments of any kind over a wide range of input voltages; also for commercial variations in the sixty-cycle frequency and for ambient temperatures between thirty-two and 110 degrees Fahrenheit. It may be used

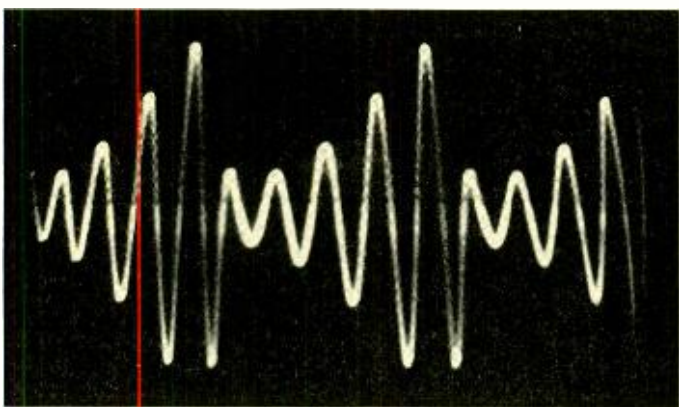

Fig. 2—Wave form of the signal

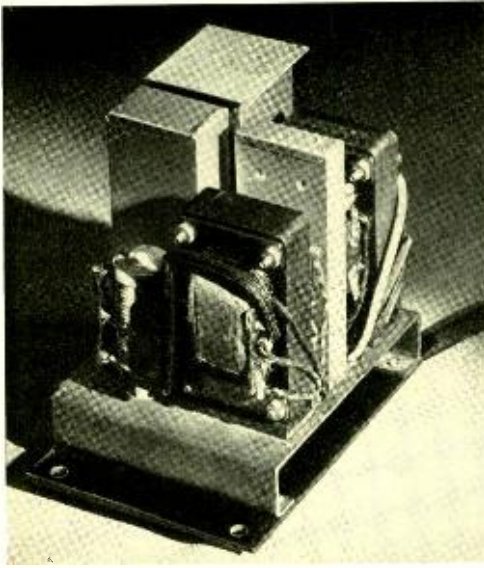

Fig. 3—The generator with cover removed

continuously with any of the output terminals short-circuited, without danger of overheating or injury to the circuit elements and there is no appreciable increase in the power drawn from the line over the normal input of approximately two watts.

A reserve source of tones has to be provided for unattended community offices equipped with 101A static tone generators because these generators are operated from sixty-cycle commercial power. An alternator connected to the central-office battery would ordinarily be used to keep the frequency generator going when the regular supply fails, but the offices in question are already equipped with vibrating relays operated from that battery and they offer a reserve tone source at no additional expense. Since these relays operate only during the infrequent intervals of commercial power failure, con-

tact and other wear that is encountered is practically eliminated.

The 101A generator is connected as shown in Figure 4 to make the vibrating relays supply the tones automatically in the event of power failure. Automatic transfer is made by the release of alarm relay A. This relay in turn releases relay B which removes the ground from the dial and busy-tone circuits of the 101A generator and closes a normally open path for the tone-start ground to the vibrating relay generators. These generators then operate whenever a call maintains a ground on the tone-start lead. Relay A also provides an alarm to indicate the failure.

The 101A frequency generator is mounted with its associated alarm and transfer relays on a small relay rack panel as shown in the headpiece and in Figure 3. This equipment has been placed in service in community dial offices during the past year.

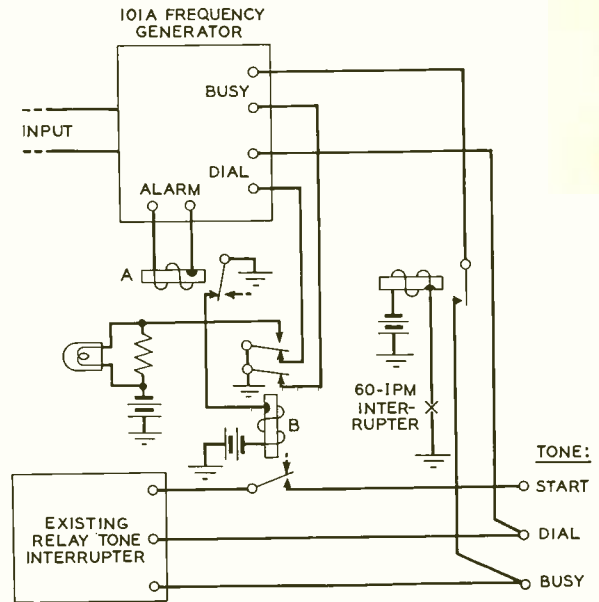
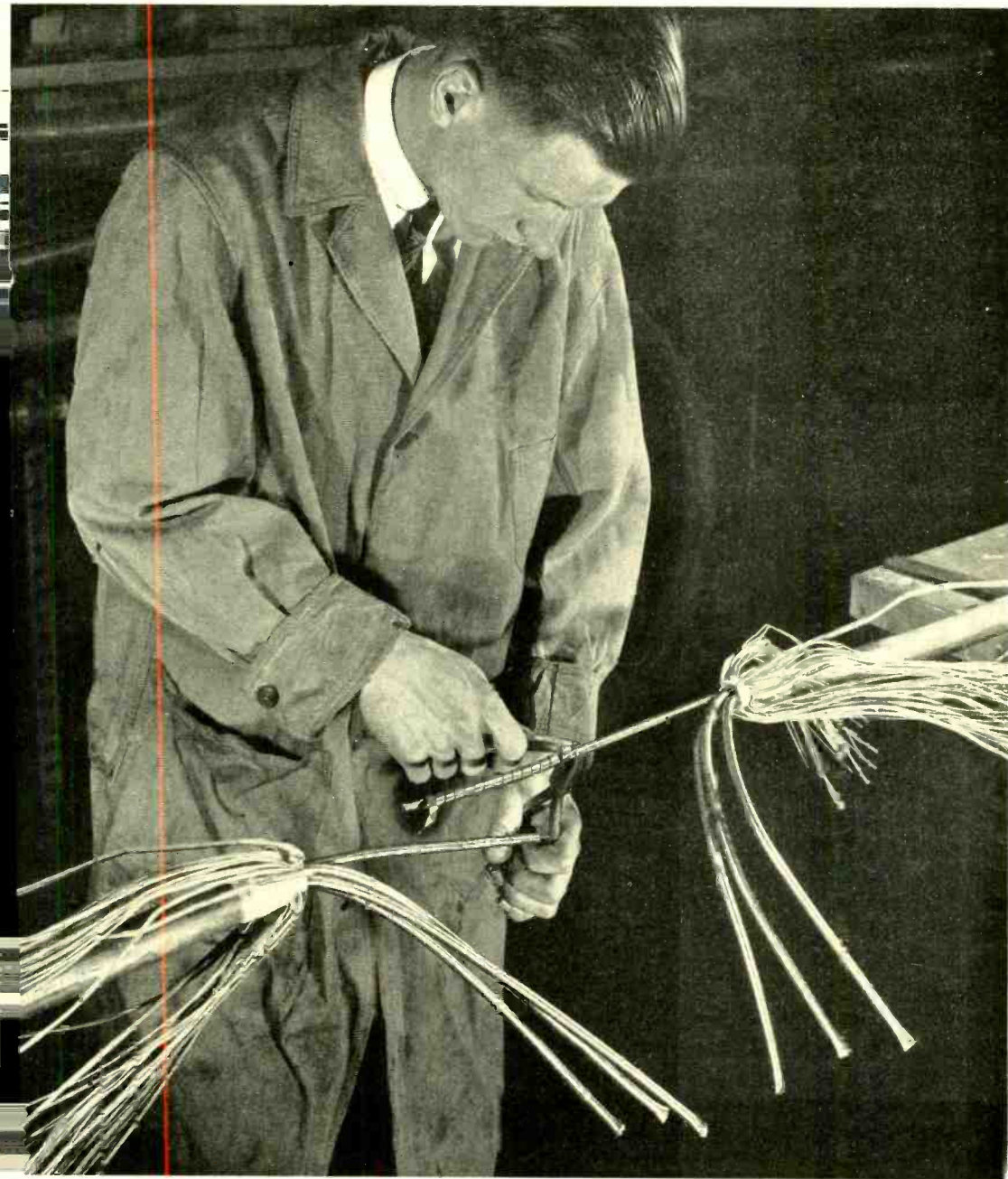

Fig. 4—Circuit for emergency transfer of tone supply to buzzing relays

# NEWS AND PICTURES



*Splicing a coaxial cable*



## News of the Month

### WAR-TIME ACTIVITIES OF THE LABORATORIES

DURING THE YEARS 1940-41 the Laboratories' program of research and development was altered to fit the changing national

situation. An increasing proportion of its technical work was undertaken at the request of the military departments of the U. S. Government. A score and more of executives and members of the technical staff of the Laboratories served by appointment on committees for defense, which were formed by Government agencies, or acted as consultants to them. Less time was expended on the future problems of telephony and more upon the immediate and emergency problems of engineering and design, the solution of which would assist Bell System Companies to meet their rapidly enlarging demands for communication services. Scarcities of raw materials of communication equipment, also, required a considerable amount of engineering work and of redesign to permit the substitution of less scarce materials.

By the time war was declared in December, 1941, about half of the members of the technical staff of the Laboratories were working directly on problems of defense. The largest part of their work was the development for military departments of the United States of systems of communication and of special devices and military equipment, for which the Laboratories' research background, techniques and highly trained personnel were peculiarly fitted. Loyal cooperation in these war-time activities of the technical departments were all the other individuals and staff groups of the Laboratories.



*As part of the emergency precautionary measures taken against the possibility of air raids, stirrup pumps, pails, bags of sand and long-handled shovels have been distributed to strategic areas in all buildings. W. A. Tracy (right), Sector Warden appointed by the Office of Civilian Defense, describes to S. H. Willard, Plant Manager, and G. F. Fowler, Emergency Protection Coördinator, the operation of a special nozzle for the effective fighting of incendiaries*



Just as an army depends upon its service and supply groups, the technical staff relies upon all the other men and women in the Laboratories. So large a part of the Laboratories' effort is today directed to the emergency problems of military equipment and of national communication services that all those who assist in service and supply are taking part in winning the war.

#### PREPARATION FOR AIR RAIDS

EVERY REASONABLE PRECAUTION is being taken by the Laboratories to prepare against the possibility of an air raid and to promote the safety of employees. On December 29, GEORGE F. FOWLER was appointed Emergency Protection Coördinator, with the responsibility for coördinating all emergency activities in connection with raid precautions and procedures, admission to buildings, and the protection of personnel and property.

Under the direction of W. A. TRACY, as Sector Warden and Alternate Zone Warden appointed by the Office of Civilian Defense, and six alternate Sector Wardens, an organization consisting of senior post wardens and wardens has been set up and trained. This unit consists of nine senior post wardens and sixty-five wardens at West Street, two and twenty-two, respectively, at the Graybar-Varick building and one and nine at the Davis building. The duties of the Sector Wardens cover air-raid observations, reporting and fighting incendiaries, fire watchers, policing buildings, traffic control, protection from unexploded missiles, gas detection and warnings, sanitary services, shelter areas and blackout operations in and outside buildings. Stirrup pumps, pails, bags of sand and long-handled shovels have been acquired and distributed to strategic areas in all buildings.

To cover emergency fire fighting, alarms to the city fire department, incendiary bomb

fighting and fire watchers, a fire brigade has been formed by W. WISSEL. Three rescue squads have been formed by J. C. JESKIE which, in addition to rescue work, will cover demolition, shoring, clearance, damage survey and permanent repairs.

First Aid squads have been formed by J. S. EDWARDS and L. E. COON under the guidance of the Medical Department. A decontamination squad has been organized by B. L. CLARKE, subject to call to determine all phases of the chemical aspects in the event of an air raid.

A. M. NICHOLSON was given the responsibility to execute all blackouts necessary and to make a survey to determine the areas throughout the various buildings that are being occupied after regular working hours to assist in the determination of areas to be treated. By January 10, all windows in stairways, toilets and skylights were blacked



*Blacking out a skylight on top of the West Street building. Left to right—Walter Gillis, Thomas Dorsey, and Thomas Solan, supervisor of the Plant Department's paint group*



*Ann Weeber, H. W. Baker, P. W. Swenson and Fred Frampton examine an exhibit showing the strides made by the Western Electric Company in the quest for alternate materials*

will eventually consist of approximately 15 chemists. The General Methods Committee under the direction of R. H. WILSON has formed plans for the preservation of certain company records by the photostatic process, microphotography and dispersion. Plans for a complete intercommunicating and signaling system to be used in the event of an alert alarm are being formulated by A. TRADUP.

Similar emergency precautionary services are being inaugurated at all of the Laboratories' properties in New Jersey.

### HIGHLIGHTS IN THE BELL SYSTEM DURING 1941

DEMAND FOR TELEPHONE SERVICE during the past year was the greatest in history. It was necessary to care for nearly twice the average increase in the number of telephones and nearly three times the average increase in toll and long distance conversations. Bell System telephones increased about 1,360,000, a record gain, to a total of about 18,840,000. With Uncle Sam and all his nephews and nieces reaching for the telephone as never before, calls per day moved up from an average of about 79,000,000 in 1940 to around 85,000,000 in 1941.

All told, more than a billion toll and long distance messages went over the wires in

out, permitting these areas to be lighted at all times.

In addition to the definite steps that have been described above, plans are under way for other precautionary measures. L. E. GAIGE, commander of the Western Electric Post of the American Legion, is organizing some 150 members who are with the Laboratories. This group will be responsible as an auxiliary corps for the prevention of panic and sabotage and other special assignments in connection with personnel and plant protection. Additional First Aid squads are being organized to give a more complete coverage of all the buildings in New York and New Jersey. The decontamination squad is being augmented and



*E. I. Pratt of the Western Electric Company arranges one of the two display cabinets which graphically demonstrated the steps being taken to replace aluminum, nickel, zinc, magnesium, crude rubber, phenol varnish and silk. The cabinets were on display in the Restaurant*

1941, about 15 per cent over the previous year. The longer haul business in recent months has been running from 40 to 50 per cent above January, 1940, and with the outbreak of war went even higher. Monday, December 8, the day after Japan attacked Pearl Harbor, was the busiest day in Long Distance history. For 1941 as a whole, longer haul messages increased about 30 per cent over 1940.

Construction of new telephone plant last year cost the System about \$420,000,000, and more would have been spent if more materials had been available. More than a million circuit-miles were added to the Long Distance network. About 950,000 dial central-office lines were installed during the year.

At the start of 1941 there were about 322,000 at work in the System, including Western Electric and the Laboratories. Now there are about 380,000.

Demands on radio telephone service went up like everything else. Overseas traffic increased about 70 per cent over 1940, due to upsurges in trans-pacific and Pan American calls. Vessels equipped for coastal and harbor service increased by several hundred. By November, 1941, there were more than 3,200 vessels that had been so equipped.

At the end of the year 63 per cent of all Bell telephones were dial operated. Nearly four-fifths of the System's telephones were hand sets, and about one-third were combined sets.

One of the principal problems in giving service in 1941 was the problem of materials. Among the steps taken to meet the changed conditions were:

1. A program of substitutions was carried out to reduce requirements for several scarce materials.

2. Betterment projects not essential for continuing the present service were deferred.

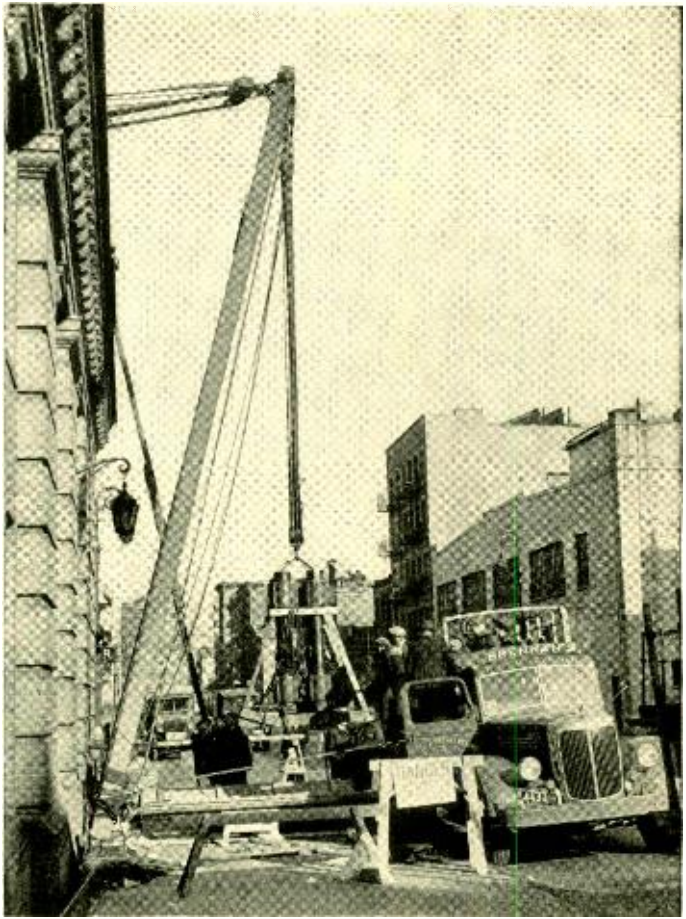

*Heavy metallurgical equipment on its way from Basement H to the laboratories at Murray Hill*

3. Repair and reuse of existing materials and facilities were at first stepped up and later greatly extended.

4. Sales effort was first reduced and then discontinued altogether.

5. Dial conversions were reduced and later practically eliminated.

6. The engineering of necessary new exchange plant was put on a strictly short-term basis. Under the revised program, new cables may contain only enough wires to meet requirements for two years and dial central-office additions may be adequate for only one year's needs.

7. Wires smaller than those normally called for were employed in cables and also in line-wire installations.

8. The operating companies endeavored to impress on customers the wisdom of



*James W. Bishop (left) of The Edison Institute Museum at Dearborn, Michigan, and W. C. F. Farnell, Curator of the Bell System Historical Museum, inspect the Institute's telephone exhibits. Mr. Farnell assisted Mr. Bishop in the selection and classification of the various exhibits. An appreciation from Henry Ford to Arthur W. Page of the A T & T on the Bell System's contributions to this exhibit appears on the opposite page*

avoiding requests for non-essential service.

Briefly, this program calls for doing nothing that isn't necessary, for doing the necessary with the least possible consumption of new materials, and for using, repairing, reusing and stretching every available facility to the limit.

It may cost more to take down a piece of rubber-covered wire, repair it, splice it to another piece and use it over again than it would cost to junk it and use a new piece. But it saves copper and rubber for more essential uses.

It may cost more to add a little cable

than a big one, when another little one has to be placed in a couple of years. But it saves copper and lead during those two years.

It may cost more, in the long run, to engineer dial additions to meet estimated requirements for a period of only one year. But it saves copper and steel now.

The revised cable construction program will, it is expected, save about 13,000 tons of copper and 20,000 tons of lead annually. Measures to conserve copper line wire will save about 9,000 tons of copper annually, and the application of modified methods in using rubber-covered wire will save some 2,000 tons of copper and 300 tons of rubber a year. Restrictions on dial installations are expected to give an annual saving of about 3,000 tons of copper and about 5,000 tons of steel.

Those are examples only. The principles involved have been applied throughout the entire range of the engineering, operation and maintenance of the telephone plant.

The point of greatest pressure as demand for telephone services leaped upward in 1941 was long distance. Of the more than one million circuit-miles added to the toll net-

work in 1941, more than half were added through the application of carrier systems. The expansion of the type-J, type-K and coaxial carrier systems was the subject of an article which will be found on page 112 of the December RECORD.

Also, during 1941, means were developed to operate more type-C (three-channel) carrier systems on "phantomed" open-wire lines than has been possible previously. This is discussed in the article on page 158.

Late in the year the first radio telephone system to embody the use of type-K carrier was placed in service between Nor-

folk and Cape Charles, Virginia, across the mouth of Chesapeake Bay. The radio transmitters and receivers operate at ultra-high frequencies, in the 155-165-megacycle range. By this radio link many miles of roundabout wire circuits are saved, and the carrier application makes available as many as twelve telephone channels.

### 1941 CHRISTMAS HOLIDAY LONG DISTANCE TRAFFIC

LONG DISTANCE CALLS on Christmas Eve were about 26 per cent above last year and the increase on Christmas Day was 7 per cent. For the overall period calls were about 12 per cent greater than a year ago.

Loads were especially heavy on trans-continental lines and routes serving the South and Southwest. In general, delays were not as severe as they were last year and the handling of traffic ran more smoothly. One reason for this was the excellent coöperation of the public, which seemed to have a good understanding of the situation. Many instances of the forbearance of telephone users indicated that the advertising efforts of the Bell System to tell the public the facts about the Christmas problem had been effective.

Another factor making for better handling of holiday calls was that for a good many months now, operating forces have been working under circumstances where the traffic crowds facilities. With this experience behind them, many operators found their problems in handling Christmas calls less out of the ordinary than in past years and were able to carry the job through with greater facility.

Figures from a number of toll offices serving Army camps show that the use of long distance on Christmas Day was about 85 per cent above a year ago. Not quite 26,000 calls were made through these

offices, compared with about 14,000 last year. Before the outbreak of war, about 450,000 men were stationed in the camps which the 15 offices serve.

Overseas messages on Christmas Eve numbered 341, about 9 per cent less than in 1940, and on Christmas Day they totaled 524, or 27 per cent less.

### COLLOQUIUM

AT THE DECEMBER 15 meeting of the Colloquium, Dr. Phillippe Le Corbeiller, lecturer at Harvard and at New York University, discussed *The Efficiency of Non-Linear Oscillators*. The oscillators considered satisfy a non-linear differential equation of the second order in which the two extreme coefficients are constants, whereas the middle coefficient (resistance) is controlled by

*Henry Ford*  
*Dearborn, Mich.*

July  
31  
1941

Mr Arthur W Page Vice-President  
American Telephone & Telegraph Co  
195 Broadway  
New York City

Dear Mr Page:

The display in The Edison Institute Museum which traces the historical development and growth of telephone communication has been completed and now is on public exhibition.

More than ten years ago we invited the Michigan Bell Telephone Company to contribute a display of this sort and later that Company's complete historical collection was turned over to us. Subsequently, American Telephone and Telegraph Company added certain pieces of equipment to supplement the collection. More recently, you made arrangements for a display of loading coils and vacuum tubes which, I understand, were especially designed and assembled by the Bell Telephone Laboratories.

This letter conveys my personal gratitude both to the American Telephone and Telegraph Company and your Laboratories for the splendid cooperation given us. Our Museum, we feel, would not be complete without this representative display of the telephone art which has been developed by the Bell System and which has played so prominent a part in the growth and development of modern America. As telephony continues to progress, I hope that the Bell System will continue to keep alive its interest in The Edison Institute Museum and expand this exhibit accordingly.

Sincerely yours,

*Henry Ford*



*When G. W. Elmen retired in December over ninety of his associates gathered at a luncheon held in his honor. In the photograph we see Harvey Fletcher presenting to Dr. Elmen his life-membership certificate in the Telephone Pioneers of America while Edward Montchyk, who retired in 1939, and R. M. Bozorth look on*

either current or voltage. Energy is supplied by a d-c source during the part of the period when this resistance is negative.

The non-linear negative-resistance device is defined graphically (not analytically) by its characteristic. Suitable modifications of previous treatments by van der Pol and Lienard lead to a simple and accurate construction of the curve defining any transient solution, and in particular of the closed curve corresponding to the asymptotic periodic solution. Simple energy relations hold with regard to this closed curve. The efficiency of the power-transformation from frequency zero to the oscillator frequency can thus be evaluated, and certain conclusions drawn.

### RALPH BOWN RETURNS FROM LONDON

FROM A CONFIDENTIAL MISSION to England, undertaken at the request of the National Defense Research Committee, RALPH BOWN returned safely on December 23. He left New York on September 24 by airplane, arriving in London on the 28th via Bermuda, Horta and Lisbon. While in England he

visited Liverpool, Birmingham, Bristol and Coventry and the "invasion coast."

Commenting on his trip, Mr. Bown noted that prices for common articles were not much different from those in New York. Few demolished buildings had been replaced, but the streets had been repaired. The country was on "double daylight" time—i.e., two hours ahead of Greenwich time. No bombing took place in his vicinity. The blackout, however, was complete. Standing in the middle of Piccadilly, he could see the stars as plainly as if in the country. Starlight is

not just a romantic idea but a real illuminant—at least by contrast with pitch darkness on an overcast night. Pedestrians carry small flashlights, which will show up the curb height but are useless to read street signs or house numbers.

Leaving England on November 20 by plane, Mr. Bown was grounded for several days in Lisbon. Before his turn was reached, war with the United States broke out and plane service became doubtful. Fortunately an American steamship came in, and he was able to get passage aboard her. For the first day they were convoyed by an airplane; from then until they reached Bermuda no warcraft were sighted. For the rest of the voyage, the ship was in contact with our own Navy.

### OUT-OF-HOUR COURSES

THE SPRING TERM of the Laboratories' Out-of-Hour Courses started during the week of January 26. In addition to the courses continued from the fall term, there were two new courses—*Practice in Shorthand Dictation* with MISS M. C. BRAINARD as the instructor and several classes in *First*

*Aid*, both Standard and Advanced Courses.

The courses continued from last fall are *The Combination of Frequency Curves in Engineering*, R. I. WILKINSON; *Interpretation of the Conductance Characteristics of Pentodes*, T. SLONCZEWSKI; *Electromagnetic Theory and Its Applications*, S. A. SCHELKUNOFF; *Network Analysis and Feedback Amplifier Design*, R. L. DIETZOLD; and *Telephone Switching Systems*, J. W. DEHN.

### MILITARY ITEMS

WILLIAM HERRIOTT has been granted a personal leave of absence in order to work for the NDRC.

GEORGE M. RICHARDS, on military leave of absence since December 15, first went to the Aviation Cadet Replacement Center, Maxwell Field, Montgomery, Ala., and later to Helena Aero-Tech., Helena, Ark.

HAROLD B. GUERCI, on January 7, was granted a military leave of absence. He is now a Lieutenant in the 910th Coast Artillery (Anti-Aircraft), Fort Totten, N. Y.

NELS C. YOUNGSTROM, Naval Communications, Third Naval District, has been promoted to the rank of Lieutenant Commander. HARVEY N. MISENHEIMER, Signal Corps Board, Fort Monmouth, N. J., has been promoted to the rank of Major. WILLIAM W. STURDY, Office of the Chief Signal Officer, Washington, has been promoted to the rank of Major.

W. J. GALBRAITH, on leave as a Major in the Infantry Reserve on active duty with the Signal Corps, writes that he is now in the Department of Training Literature on the Staff of the Signal Corps School at Fort Monmouth, New Jersey.

LIEUT. EINAR REINBERG, upon his return from the maneuvers in the Carolinas, was ordered to the Infantry School at Fort Benning, Ga., for three months to take a special course in the use of rifles and heavy weapons.

CHARLES C. ROCK, who has

been on a personal leave of absence for active duty in the Naval Reserve at the United States Navy Yard in Brooklyn, has returned to the Laboratories.

### NEWS NOTES

D. M. BLACK is the engineer shown in the Frontispiece on page 141 and M. W. BOWKER in the photograph on page i of the News Notes.

A RECENT ISSUE of *Nature* (London) contained an abstract of M. E. KROM's article *No-Such-Number Tone for Dial Systems*, published in the RECORD for April, 1941.

C. H. TOWNES presented a paper, *Theory of Cathode Sputtering*, before the Physics Colloquium, University of Pennsylvania.

R. R. WILLIAMS spoke on the subject *The Chemical Descent of Man* before the Engineering Institute of Canada in Montreal on December 12 and the Royal Canadian Institute in Toronto on December 13.

R. M. BURNS discussed *Protective Coatings for Corrosion Prevention* before the Indianapolis chapter of the American Society for Metals on December 15.



*In addition to articles of lasting value, a number of humorous gifts were made to J. N. Walters at the time he retired last December. His hobby of cameras was hit off by the presentation of several antique cameras and his interest in central-office maintenance by a heroic size jack which was to remind him that, although he was leaving us, test jacks would always be an essential part of circuit design*

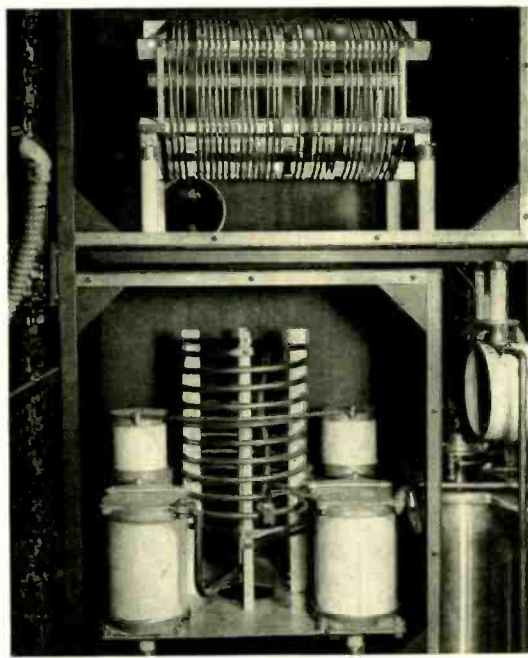
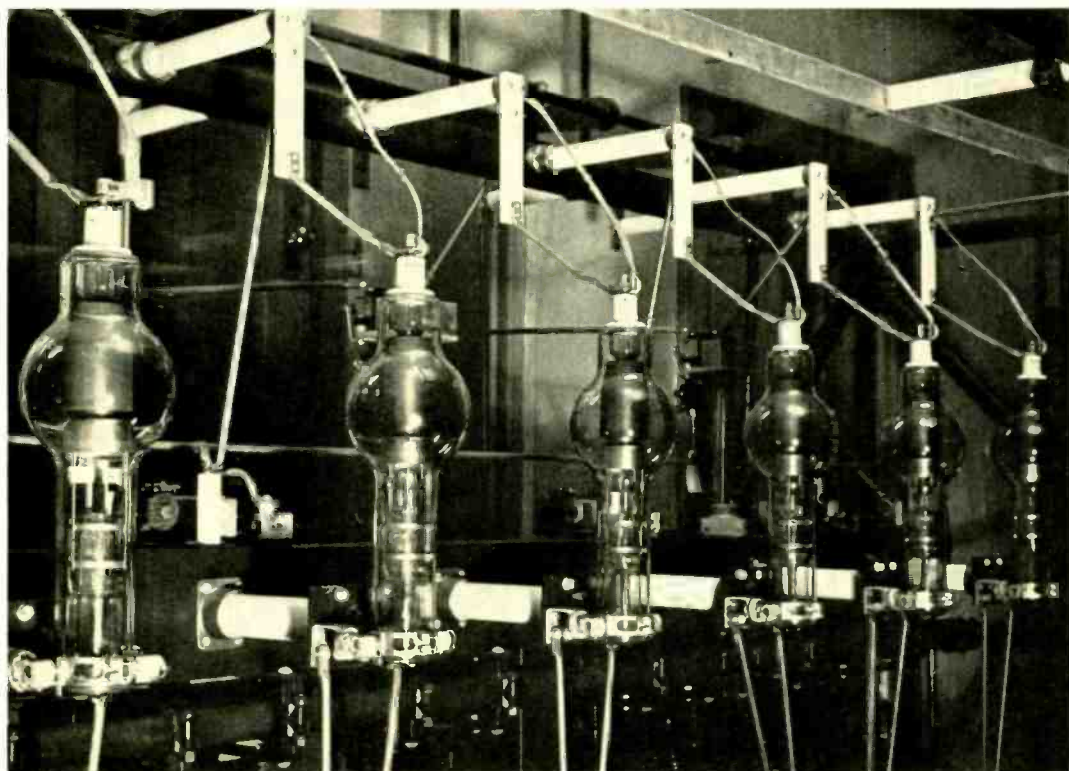

*At Rutherford, New Jersey, WHN has recently placed in operation its new 50,000-watt radio transmitter, developed for Western Electric by the Laboratories. Top—Bank of 18,000-volt rectifier tubes. Lower left—J. C. Herber adjusts a relay in the control unit. Lower right—Plate tuning and harmonic filter inductances, and condensers in the 50-kw amplifier unit*

[ x ]

February 1942



MEMBERS OF THE LABORATORIES who attended the annual meeting of the American Physical Society, held in Princeton from December 29 to 31, were A. J. AHEARN, J. A. BECKER, R. M. BOZORTH, W. H. BRATTAIN, K. K. DARROW, C. J. DAVISSON, L. H. GERMER, F. S. GOUCHER, C. B. GREEN, F. E. HAWORTH, A. L. JOHNSRUD, J. J. LANDER, F. C. NIX, G. L. PEARSON, A. M. SKELLETT and G. W. WILLARD. At the business meeting K. K. DARROW was re-elected secretary of the Society. R. M. BOZORTH presided at a session which was devoted to a discussion of *The Solid State*.

PAPERS ENTITLED *Dielectric Behavior of Some Ceramic Insulation* by S. O. MORGAN and *The Relationship Between Composition and Dielectric Properties of Some Low-Loss Ceramics* by M. D. RIGTERINK were presented at the Twenty-Seventh Annual Convention of the Ceramics Association of New Jersey. This convention, which was held in New Brunswick on December 19, 1941, was also attended by C. J. CHRISTENSEN.

TWO WESTERN ELECTRIC radio transmitters were described in an article, *F-M and A-M Transmitters of the Month*, published in the December issue of *Communications*. Both transmitters went on the air recently—the 10-kw F-M transmitter of Station W71NY, owned by WOR, key

station of the Mutual Broadcasting System, and the 50-kw A-M transmitter of Station WHN. Three photographs of the WHN transmitter are shown on the opposite page. In describing these transmitters reference is made to the contributions made by W. H. DOHERTY in their design and to A. A. SKENE who recently presented a paper on the F-M method before the I.R.E.

F. A. GOSS is serving his first term on the Morristown Borough Council. At present he is also chairman of the lighting committee and serves as a member of the road and finance committees.

J. E. RANGES was at Fort Monmouth in connection with the loading of rubber-covered field cable and spiral-four cable.

W. J. MEANS visited the General Radio Company at Cambridge, Mass., to review the material situation on precision air condensers for 17-type oscillators.

A. H. VOLZ, at the Hardwick Hindle Company in Newark, discussed power rheostat problems.

D. D. MILLER was in Hawthorne in connection with step-by-step, panel and relay apparatus.

G. B. BAKER visited the Englishtown, N. J., central office of the New Jersey Bell Telephone Company on matters pertaining to step-by-step relays.

---

MEMBERS OF THE LABORATORIES TO WHOM PATENTS WERE ISSUED  
DURING THE MONTHS OF NOVEMBER AND DECEMBER

T. Aamodt	H. W. Goff	F. B. Llewellyn	J. R. Pierce (2)
L. H. Allen	C. S. Gordon	M. A. Logan	H. T. Reeve
W. M. Bishop	C. W. Halligan	C. A. Lovell (2)	W. A. Rhodes
N. Blount (2)	W. H. Harvey	W. R. Lundry	V. L. Ronci
H. G. W. Brown	W. Herriott	W. A. Marrison	A. L. Samuel
C. R. Burrows	R. E. Hersey (2)	W. P. Mason (2)	L. R. Schreiner
E. T. Burton	W. H. C. Higgins	W. H. Matthies	E. E. Schumacher
W. W. Carpenter	Francis A. Hubbard	R. G. McCurdy	O. A. Shann
J. G. Chaffee	A. R. Kemp	P. Mertz	A. M. Skellett
C. J. Christensen	R. J. Kircher	S. T. Meyers	T. Slonczewski
K. G. Compton	W. C. Kleinfelder	D. Mitchell (3)	N. R. Stryker
T. H. Crabtree	L. F. Koerner	H. R. Moore (2)	R. A. Sykes
T. L. Dowey	O. H. Kopp	O. Myers	D. E. Trucksess
S. O. Ekstrand	F. A. Korn (2)	R. C. Newhouse	W. W. Van Roosbroeck
W. B. Ellwood (2)	H. K. Krantz	J. B. Newsom	J. N. Walters
L. Espenschied	L. E. Krebs	H. Nyquist	E. C. Wente (2)
E. P. Felch, Jr.	E. Lakatos	C. V. Parker	G. W. Willard
E. W. Flint	W. Y. Lang	H. Peters	R. C. Winans
M. S. Glass			D. E. Wooldridge

---

## Some Members of the Laboratories

---

THIS IS THE SECOND ISSUE in which the RECORD is publishing biographies of members of the Laboratories chosen by lot from those who have been with us more than six months and less than twenty-one years.

Here is the mechanism of choice: The Payroll Department has assigned to everyone an individual number somewhere between 10,000 and 16,000. The entire 6000



*Miss Alta Boch*

numbers might be written on slips of paper, mixed in a bowl, and drawn, like the Selective Service lottery. But a better way presents itself. There is available in the Library a Table of Random Numbers, each of four digits, so thoroughly mixed that no pattern of appearances of any digit can be discerned. A sequence of these numbers was written down, prefixed with 1 to bring the lowest one above 10,000; and all above 16,000 were omitted. The remainder were sent to the Payroll Department who inserted the names and department numbers, and to the Personnel Department who entered service dates.

ALTA BOCH is a clerk in the Current Engineering group of Switching Development, which she entered as a "mail girl" when she graduated from Richmond Hill High School. Her job is to fill in forms embodying circuit engineers' requirements for relays, and to see that copies are properly distributed and filed. Out of hours, she studies singing—her voice is mezzo-soprano—and she is a recent recruit of the Bell Laboratories Glee Club. Concerts and occasional bowling are her recreations.

The Laboratories is not without its intramural romances, as Miss Boch will admit when anyone admires her engagement ring. Her associates wish her happiness, but they will miss her vivacity and good humor when the time comes for her to retire to private life.

\* \* \* \* \*

BECAUSE ANOTHER man had worked in these Laboratories and liked it, HOWARD B. BRIGGS is here today. His friend—S. A. SCHELKUNOFF of Mathematical Research—

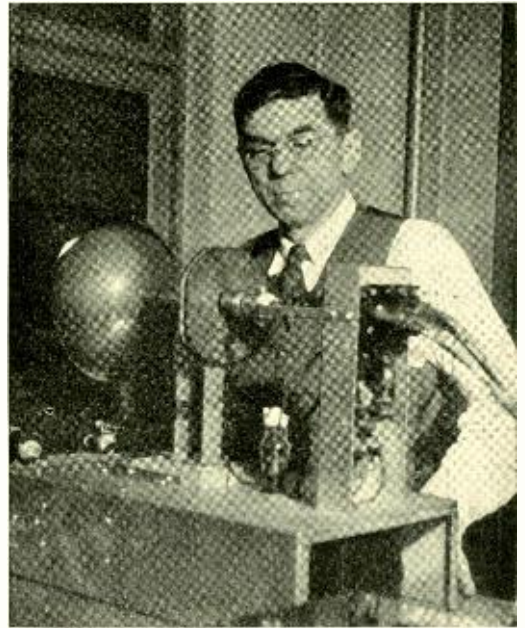

*Howard B. Briggs*

is also here; but this story is about Dr. Briggs. Born in South Dakota and prepared by public schools in various midwestern towns, Mr. Briggs entered the University of Wisconsin in 1915. His education was interrupted by World War I, during the last part of which he was overseas as a Lieutenant of Infantry. Graduate work in physics interspersed with teaching at Wisconsin and Chicago won his Ph.D. magna cum laude at the latter university in 1925 and he then became an assistant professor at Washington State. Here he came to know



*George Schuell*

Dr. Schelkunoff; and when in 1929 the Laboratories made him an offer he accepted it.

On entering, Dr. Briggs joined the Electro-Optical Research Department and has been concerned with photo-electric investigation ever since. One of his important projects was the correlation of optical properties of certain metals with their photo-electric emission; articles on that subject appeared in professional journals, and in the RECORD for July, 1939. He has also studied electro-optical devices from the television standpoint—the frequency vs. response characteristics of gas-filled photo-electric cells and the time lag of fluorescent screens.

*February 1942*



*Melville L. Weber*

Outside the Laboratories, Dr. Briggs might well be selected as the typical citizen of Chatham, New Jersey. He is a member of the School Board; his wife is active in their church; his son is a freshman in high school and his daughter is in the sixth grade. For relaxation, he reads the current weeklies; for recreation he and his boy build and fly model airplanes powered by small motors; and he plays bridge when the social amenities require it.

\* \* \* \* \*

FOR FIVE YEARS an instrument maker in the Development Shop, GEORGE SCHUELL enjoys creating things there; he rounds out his life with his pleasure in music and the great outdoors. With Mrs. Schuell he spends his vacation afoot in the Catskills; of an evening in his home in Ridgewood, Queens, he reads, or plays some of his collection of classical records. Pictured with him is a screw press on which he is forming light parts for an experimental vacuum tube.

\* \* \* \* \*

BEFORE AN engineer can find out if an idea is any good, a working model must be built and tried out. That is where a Technical Assistant such as MELVILLE L. WEBER is useful. The engineer explains his pencil sketches, perhaps makes some suggestions as to mechanical arrangement of the parts, and

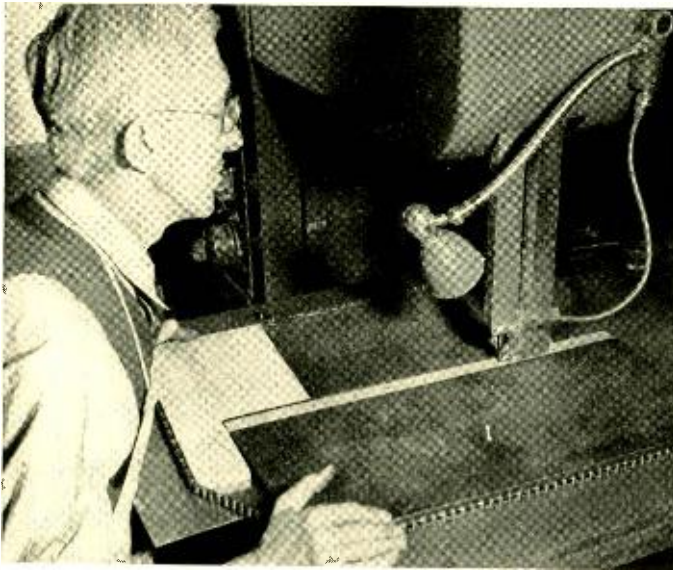

*Joseph Kelly cutting a steel plate on a bandsaw in the Development Shop*

then it is up to the "T.A." to assemble the relays, resistances, condensers, and what not on mounting strips or drilled panels, wire them up, and check his work with the sketches. Then he helps the engineer make functional tests, and modifies the circuit as need be.

Mr. Weber entered the Laboratories in 1922 from Haverstraw High School as a messenger. Eventually he became a wireman in Research Service, and then in that department's shop he wound coils for dynamic loud speakers and microphones. After several years he transferred to A. M. CURTIS' circuit research group, where he is now a Technical Assistant.

In his home town near Nyack, Mr. Weber is active in Scouting; his 25 years took him through all ranks to Eagle Scout and he is now District Commissioner. His interest in First Aid led him to take the Red Cross course locally and then in the Laboratories and he is now a member of the Rockland County Emergency Squad. Archery, fishing, and hunting are his recreations; with his wife and three children, he vacations by trailer and canoe in the Adirondacks.

\* \* \* \* \*

H. C. RUBLY visited the Sheet Metal Shop at Kearny to discuss the design of new steel boxes for portable testing apparatus.

F. B. WHEELER, H. H. GLENN, C. A. WEBBER and R. T. STAPLES visited the Western Electric Company at Point Breeze in connection with cord development.

J. H. WADDELL spoke on *Stereoscopic Photography* before the Raritan Photographic Society at a meeting held in New Brunswick on January 8.

THE NOVEMBER ISSUE of the *Proceedings of the I.R.E.* contains an article *Program-Operated Level-Governing Amplifier*, by W. L. BLACK and N. C. NORMAN. This paper was originally presented at the annual convention of the I.R.E. in New York City.

A. MEYER and H. W. PURCELL took part in contact noise tests in central offices of

the New Jersey Bell Telephone Company in Newark. Mr. Meyer also conducted tests of a similar nature in Orange and Paterson.

D. F. SEACORD and G. RISK, JR., were in Hartford and New Haven, Conn., in connection with contact noise studies in central offices of The Southern New England Telephone Company.

DURING THE FOURTH QUARTER of 1941 the following members of the Laboratories have been enrolled as members of the Telephone Pioneers of America.

Reuel S. Alford  
George H. Bogart  
Ivan W. Brown  
Frank J. Canavan  
John J. Collins  
Arthur F. Conk  
Henry L. Downing  
Alfred O. Easton  
George J. V. Faley  
John Filmore  
Harry P. Franz  
A. William Frey  
Fred Gebhardt  
John C. Herber  
Harry R. Jeffcoatt  
Anna E. Johnson

Samuel R. King  
A. Douglas Knowlton  
Nicola L. LaMattina  
John W. McCaw  
John Mogilski  
Philomena I. Papace  
Ludwig Pedersen  
N. Y. Priessman  
Irad S. Rafuse  
Edwin W. Rahn  
George Risk, Jr.  
R. M. Sample  
John W. Stoner  
Leland K. Swart  
Edward A. Wieland  
Salvatore J. Zammataro

MISS ESTHER RENTROP and W. E. REID completed field tests of crosstalk at type-K system frequencies on the Omaha-Denver cable and returned to New York.

C. O. CROSS and C. H. GORMAN returned

to New York while testing on the Omaha-Denver cable was interrupted to allow for new system lineups and holiday traffic. Together with E. S. WILCOX, they resumed testing work in Colorado in January.

A. J. AIKENS made tests on carrier system amplifiers in the South Orange central office of the New Jersey Bell Telephone Company.

D. F. HOTH was at Closter and Morristown, N. J., and Flushing, L. I., in connection with tests on program loops.

R. A. SHETZLINE, R. S. TUCKER and R. J. SYMONDS, at Sands Point, L. I., investigated the presence of interference in a ship-to-shore radio receiving channel.

#### RETIREMENTS

THE ACTIVE SERVICE of two members of the Plant Department was brought to a close on the thirty-first of January by the retirement of CHARLES E. WENZEL and ANDREW McLOUGHLIN under the Retirement Age Rule.

Mr. Wenzel joined the finishing shop of the Manufacturing Department of the



*Charles E. Wenzel*



*Andrew McLoughlin*

Western Electric Company here at West Street in 1900 following seven years of training in metal finishing in other companies. In 1913 he transferred to the finishing department at Hawthorne and a short time later he installed and was placed in charge of the finishing room in the Clinton Street factory at Chicago. Mr. Wenzel returned to New York in 1917 to take charge of the finishing shop of the Western Electric Distributing Shop, then at West Street, but soon moved downtown. In 1920 he set up and became foreman of the present metal and wood-finishing shop.

His forty-two years of service have placed him in a position to observe the marked advances of modern industrial methods as reflected in finishing. Mr. Wenzel cites as examples the adoption of the spraying process for japanning and, more recently, the improved methods for chromium, cadmium and "bright" zinc plating and other modernistic finishes.

Mr. McLoughlin joined the Engineering Department in 1919 as a laborer in the masonry group of the Building Shops. He later became a mason, building bridge walls in the boilers in the power

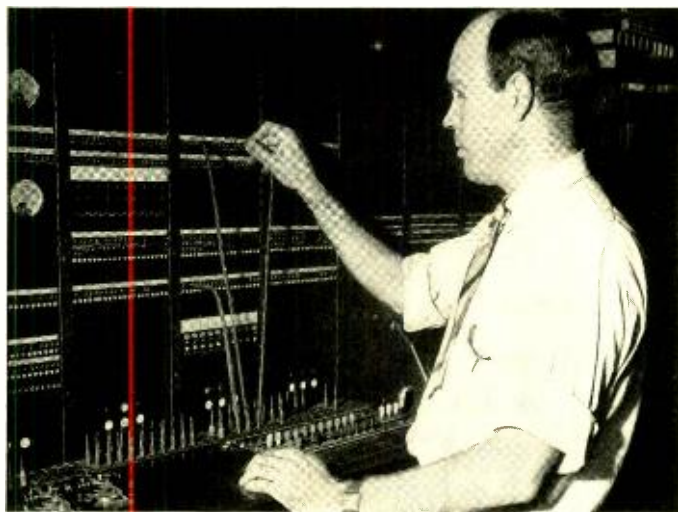

*K. E. Fitch at the No. 1 service board in the telegraph laboratory prepares to monitor and make transmission measurements on a concentration group*



OSCAR A. SHANN  
*of the Station Apparatus Development Department completed thirty years of Bell System service on January 2*



LOUIS T. COX  
*of the Switching Development Department completed thirty-five years of Bell System service on January 21*

plant and doing general work around the West Street building. More recently he assisted in the installation of the steel-frame fireproof windows which replaced the older ones, particularly those in the court.

### TWENTY-FIVE-YEAR SERVICE ANNIVERSARIES

PROUD OF HER ASSOCIATION with the Bell System during the past twenty-five years is MISS HELEN V. RYAN, who came to the Engineering Department, Western Electric Company, in 1917 as a file clerk in what is now known as the 4A Files of the Apparatus Development Department. Later she was placed in charge of the group responsible for all of the incoming and outgoing mail of the department and for the filing of all reports. More recently Miss Ryan handled the routine office work of the transmission networks, and special filters and crystal units groups of the Transmission Apparatus Development Department. Since January, 1940, as a supervisor in the Apparatus Staff Department, she has been in charge of a secretarial service group for various apparatus design groups located on the fifth and sixth floors.

Miss Ryan, a native New Yorker, was born in the Murray Hill section of Manhattan

and graduated from Washington Irving High School. She likes to spend much of her leisure time, both summer and winter, in the Pocono Mountains of Pennsylvania. Her specialty is winter sports, particularly skiing and tobogganing. She is a member of the Edward J. Hall chapter of the Telephone Pioneers of America.

\* \* \*

A. J. SNYDER's first work with the Engineering Department of the Western Electric Company was in the Physical Laboratory on life tests of dry cells and their standardization. Shortly after our entrance into the First World War he lined up the equipment for the In-

spection Laboratory that was to be used by the Division of Research and Inspection of the U. S. Army in France. He also was responsible for procuring this equipment and for sending it to France. Upon the completion of this work he returned to the Physical Laboratory where he shortly was placed in charge of the technical service group concerned with the development of oscillographs, particularly in modifying those available by the addition of control apparatus and equipment for film development. He was also responsible for the manufacture of special mica condensers. From 1921 to 1925 he attended the School of Commerce of New York University.

In 1922 Mr. Snyder transferred to the Commercial Relations Department where, after spending a short time on the commercial phases of radio broadcasting, he joined the customer's service group to handle cases chargeable to the American Telephone and Telegraph Company. This involves a thorough understanding of the work being done in order to recommend classification of the expense properly—whether to A T & T as fundamental development or to the Western as the project reached the design and manufacturing phases. When the department was reorganized in 1925 to the present system of specialists, he became responsible for the

Commercial Department's work in connection with transmission instruments for telephone and radio broadcasting purposes and for public address systems. In 1933, testing apparatus, outside plant products and station instruments were added. In 1937 Mr. Snyder became Wire Transmission System Specialist and was responsible for the commercial aspects of such projects as the New York-Philadelphia coaxial cable installation and the trial installations of the type-J and type-K carrier telephone systems. Since November, 1940, he has been concerned with the commercial phases of special government contracts.

Mr. and Mrs. Snyder live in Short Hills, New Jersey. He is very active in the Maplewood Club of which he has been a trustee for three years and is at present vice-president and chairman of the Finance Committee. He is a Telephone Pioneer and his recreations are tennis and bowling.

\* \* \* \* \*

SOON AFTER JOHN J. PARIS joined the drafting group of the Western Electric Engineering Department in 1917 he transferred to the Apparatus Development Department where he was engaged in the design and development of telephone keys, jacks and other manual apparatus. Before coming to the Bell System he had spent ten years on machine design for the American Machine and Foundry Company in Brooklyn. During the First World War Mr. Paris was con-

cerned with the development of apparatus and equipment for submarine and aircraft detection.

Following the war Mr. Paris continued the design of manual switchboard apparatus. In the early Twenties he transferred to the Apparatus Specification Department where he was engaged in the preparation of specifications for mechanical switching systems. More recently his work has covered manual switchboard apparatus.

Mr. and Mrs. Paris live in Keansburg, New Jersey. They have one son who is now in the Coast Artillery.

\* \* \* \* \*

DR. JEWETT was guest speaker at a luncheon of the Patent Departments of the Laboratories, American Telephone and Telegraph Company and Western Electric Company, held at the Hotel Pennsylvania in New York City on December 11.

M. R. MCKENNEY appeared before the Board of Appeals at the Patent Office in Washington relative to an application for a patent.

A. W. KISHPAUGH and G. F. HEUERMAN were at the Patent Office during December relative to routine patent matters.

W. A. SHEWHART was elected a director of the American Statistical Association at their annual meeting in December. On December 27, Dr. Shewhart presided at a joint meeting of the Econometric Society and the Institute of Mathematical Statistics. This



*John J. Paris*



*Miss Helen V. Ryan*

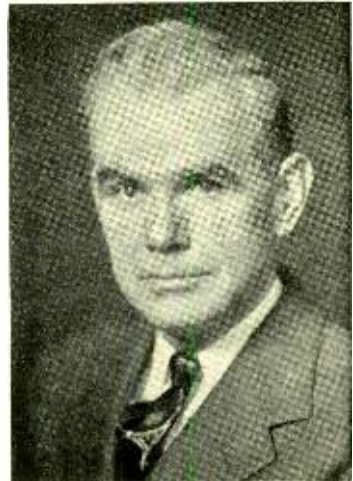

*A. J. Snyder*

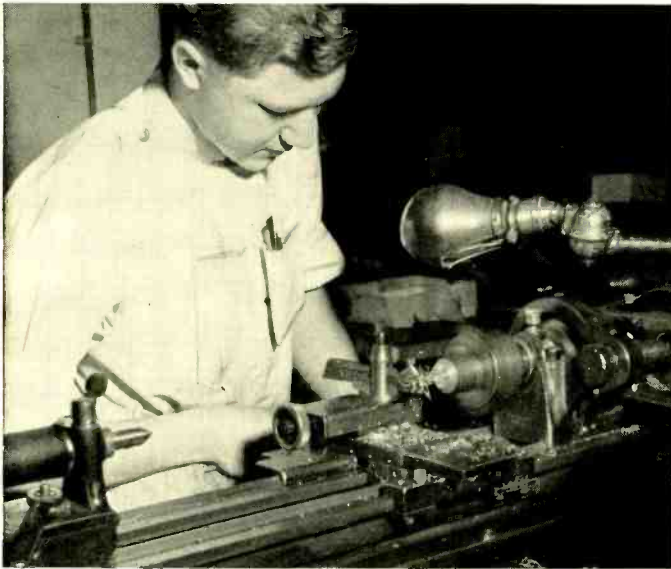

*John Zweig machining aluminum rings on an engine lathe in the Development Shop*

meeting was devoted to *Theory of Runs and Confidence Intervals*.

JOHN MILLS, on December 17, spoke on *Industrial Research* in the program of lectures on *Modern Developments in Industry* at the School of Education of New York University.

R. M. FOSTER presided as chairman at a session, devoted to *Mechanical Solution of Differential Equations*, of the joint meeting of the Institute of Mathematical Statistics and the American Statistical Association arranged with the American Mathematical Society. This meeting, also attended by JOHN RIORDAN, was held in New York City on December 28, 1941.

Mr. Foster and S. A. SCHELKUNOFF attended the Forty-Eighth Annual Convention of the American Mathematical Society in conjunction with meetings of the Mathematical Association of America, the Association of Symbolic Logic and the National Council of Teachers of Mathematics. This convention was held at Lehigh University, Bethlehem, Pa., on December 29 to 31, 1941.

E. C. MOLINA was elected a vice-president of the Institute of Mathematical Statistics at their annual meeting.

J. W. CORWIN, at the Hawthorne plant of the Western Electric Company, discussed

problems of the simplification of steel sizes and shapes.

O. J. MORZENTI and A. M. ZILLIAN have been supervising modifications to carrier telephone equipment that are now on trial between New York and Pittsburgh.

G. E. STOWE visited Princeton in connection with the installation of the type-L coaxial cable carrier current system.

U. S. FORD was in Wilmington, Del., in connection with a trial installation of equipment in that city's step-by-step central office.

D. VAN METER, at Lowellville, Ohio, observed a trial installation of dial equipment.

C. S. KNOWLTON discussed problems concerned with central-office power plants

with engineers at the General Electric Company in Schenectady, New York.

C. L. DEELWATER visited the Buffalo

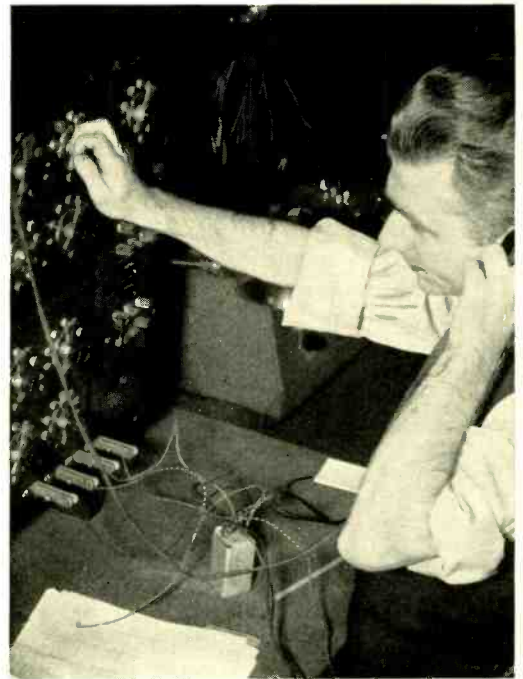

*B. Polishook, in the coil-test room of the Development Shop, measures the inductance and ratio of a retard coil*



Gasoline Motor Company on engine problems.

J. H. SOLE was at the Ft. Wayne plant of the General Electric Company on matters pertaining to the design of power plants.

\* \* \*

FRANK JOSBERGER of the Plant Department, with over thirty-two years of service with the Western Electric Company and the Laboratories, died on December 15. Mr. Josberger joined the Western Electric Company in 1909 as a belt maker at the time when practically all machines were operated from overhead drives. Later, when individual drives were superseding these, he became a millwright in the Building Shops. From 1918 to 1924 he worked as a laboratory mechanic in the machine switching laboratory. He then went to the Development Shop as a sheet-metal worker. In 1934 Mr. Josberger transferred to the sheet-metal group of the Building Shops and since then had been engaged in general maintenance work.

\* \* \* \* \*

V. T. CALLAHAN discussed maintenance of gasoline engines at Glen Rio, Texas. He also visited Minneapolis and Milwaukee.

G. B. THOMAS attended the Bell System Personnel Conference at 195 Broadway held from December 2 to 5, 1941.

B. L. CLARKE visited Hawthorne to discuss analysis of cellulose-acetate molding compound and questions of finish. Mr. Clarke also gave a talk on *Microchemistry* before the Western Connecticut Section of the American Chemical Society.

C. S. FULLER also at Hawthorne discussed with its engineers various plastics.

F. F. LUCAS, on January 6, spoke on *High-Power Metallography* before the American Society for Metals at a meeting held in Syracuse, New York.

R. A. DELLER spent November 24 and 25 in Boston and Worcester where, in company with W. E. Keith of the New England Telephone and Telegraph Company, he visited the Engineering Departments of

February 1942



Frank Josberger, 1877-1941

Massachusetts Institute of Technology, Harvard University, and Worcester Polytechnic Institute.

D. A. McLEAN with J. N. DETRICK of the Hawthorne plant of the Western Electric Company visited the Jersey City and Spotswood plants of the Peter J. Schweitzer Paper Company where they discussed problems pertaining to the chemical behavior of insulating papers.

W. J. SCULLY left for San Francisco on December 28 to observe the San Francisco and Oakland crossbar tandem offices. He will remain there until these offices are placed in service.

A. C. VELIA was at Princeton making special tests on KI flat gain controllers.

J. P. RADCLIFF went to Stevens Point to investigate the operation of some of the terminal circuits on the coaxial system.



R. D. Fracassi making noise measurements on cable carrier program equipment

J. MAURUSHAT, JR., was in Pittsburgh testing carrier program circuits over the K2 carrier system.

ENGINEERS in the Transmission Development Department participating during December in the field trial of K2 carrier equipment between New York and Pittsburgh included:

F. B. Anderson	J. G. Kreer
H. S. Black	O. H. Loynes
F. A. Brooks	J. T. O'Leary
H. C. Fleming	E. H. Perkins
T. F. Gleichmann	A. C. Velia
G. P. Wennemer	

G. W. COWLEY and C. A. W. GRIERSON are at Havana and R. L. TAMBLING and W. P. FRAWLEY at Key West, making installation tests on a new carrier system to

be put in operation over the No. 4 submarine cable between Key West and Havana.

L. H. MORRIS has returned from Minneapolis where he conducted modulation and transmission tests over the Stevens Point-Minneapolis coaxial cable.

ON DECEMBER 15 the New York-Philadelphia coaxial cable was placed in temporary commercial service. After two days there were twenty-four circuits routed over this new facility.

THE TRIAL of the 0.8-mc coaxial line equipment is now under way between Baltimore and Washington. O. D. GRISMORE is in attendance for the transmission tests.

W. M. BISHOP, Q. E. GREENWOOD, E. M. BOARDMAN, and H. B. BREHM were at Manahawkin on submarine cable tests.

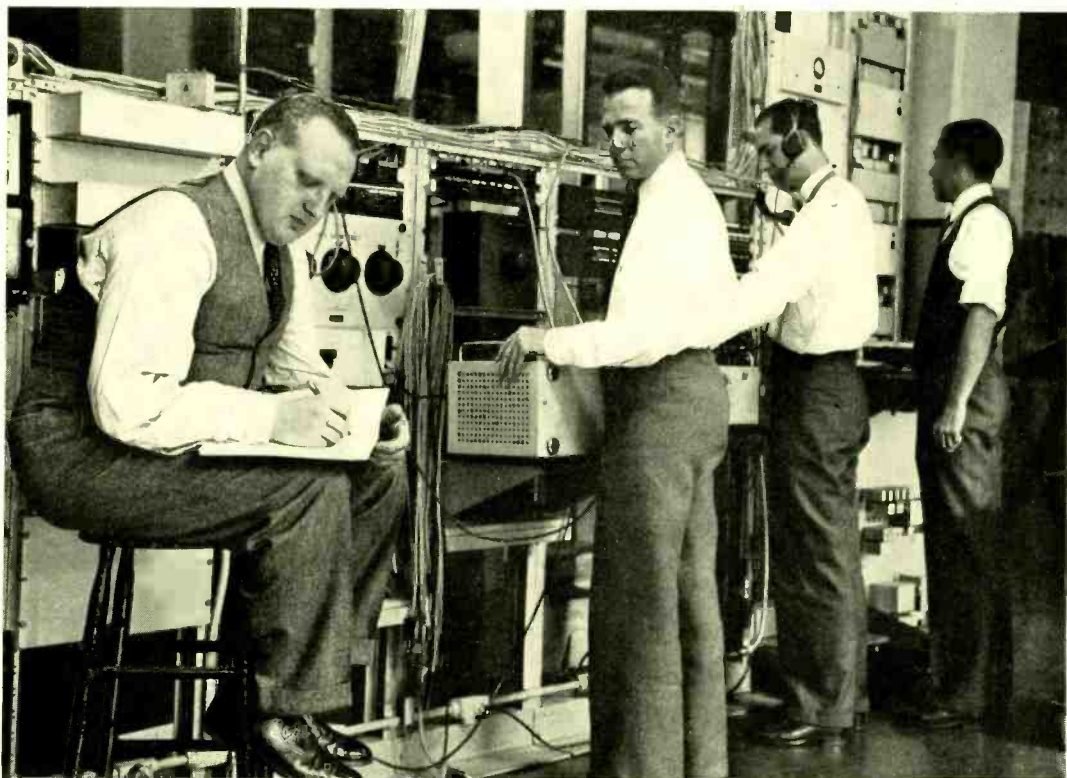

*J. Maurushat, Jr., P. V. Koos, E. H. Perkins and H. C. Fleming making transmission measurements at the Pittsburgh terminal of the K2 carrier field trial*

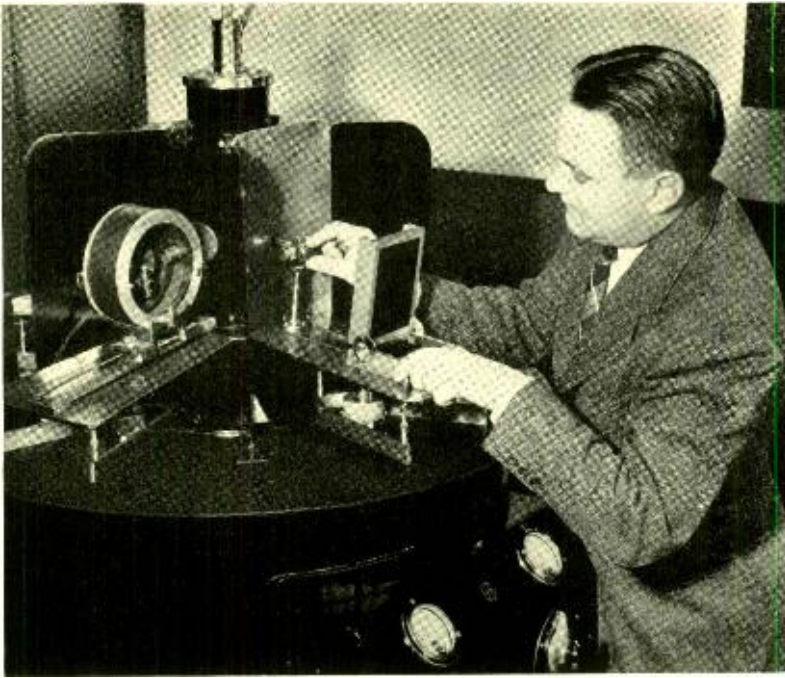

## Crystallinity in Cellulose Esters

By W. O. BAKER

*Chemical Laboratories*

**T**HE toughness, strength and flexibility of plastics which are being extensively employed as metal substitutes are influenced by the arrangement as well as the composition of their giant molecules. Plastics contain molecules thousands of times larger than those of water or gasoline; and in most cases their molecules are very long and thread-like. Derivatives of cellulose are among the most important of these chain or polymer molecules because material of that composition can be readily formed much as metals are cast. Cellulose and its derivatives are products of economic and strategic importance, easily produced in this country from cotton and wood pulp.

The present investigation concerns chiefly certain compounds such as cellulose acetate and cellulose butyrate, which are used for electrical insulation, moldings of apparatus, photographic film, airplane dopes, and lacquers. It was desired to discover the fundamental properties which make these materials resistant to shock, bending, twisting and dimensional change. The studies were undertaken on a molecular scale rather than with the usual engineering tests, and the high magnification necessary was obtained by photographing x-ray beams after they passed through selected samples of the plastics. These photographs differ from ordinary x-ray shadow pictures in that they

give diffraction patterns which can be measured to show distances between the molecules as small as a billionth of an inch, and also to indicate how the molecules are placed with respect to each other in the solid.

The samples studied were small, flat sections about one millimeter thick. This small size facilitates examination of special parts from moldings, and even thinner films from lacquers. The samples were rigidly mounted on a lead insert, Figure 1, so as to cover a small cylindrical hole through its center, thus forming a tiny pipe through which x-rays were guided from the tube where they are generated to the sample. When this minute cylindrical beam of x-rays

passes through the plastic, much of it expands into a cone because the regular layers of molecules have diffracted it. Actually, there are often many coaxial cones, whose axes are along the original, unbent beam. These cones have a common apex at the point where the x-ray beam leaves the sample on its way to the photographic plate. After three or four hours' exposure they appear on the developed photographic film as circles, and the degree of crystallinity in the sample is shown by the sharpness and the number of circles recorded.

In striking analogy to the behavior of metals, it was found that the cellulose esters could be quenched by cooling them rapidly from the molten state. The long polymer molecules were then found to be disordered with respect to each other; that is, given faces of the molecules did not all point in the same direction throughout portions of the solids, as would occur in crystals. Neighbors of a given molecule are quite randomly arranged

although there is a tendency for sections of the chains to lie side by side. They are like a company of soldiers drawn up in formation except that the men as a whole face in all directions, rather than just to the front. When these plastics are cooled slowly from the melt, however, much greater order occurs, and it is as though little squads of men through the company stood at attention facing the same way in a given squad, although all of the squads as

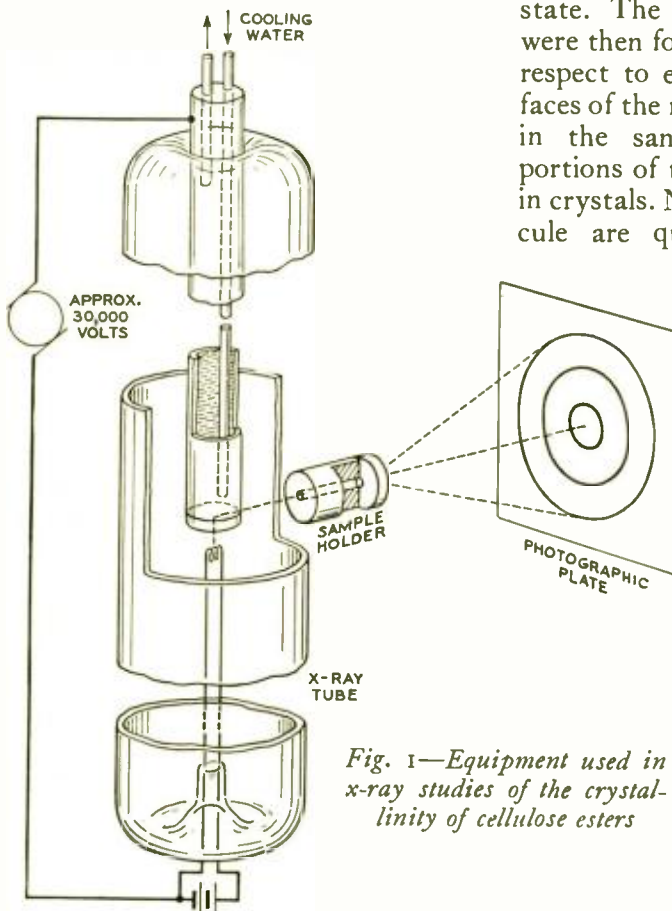

Fig. 1—Equipment used in x-ray studies of the crystallinity of cellulose esters

units do not face in the same direction. The molecules have a very ordered arrangement in local regions throughout the plastic.

When the molecules in the plastic have the maximum disorder, the material tends to be most soft and flexible and when they are most ordered, or crystallized, the material is hardest and strongest, but sometimes brittle. These extremes are illustrated by gum rubber, for instance, in which the molecules are disordered, while in ice or sugar, which are brittle, they are almost perfectly ordered. Evidently a compromise between extremes is most desirable for toughness and general industrial utility. The x-ray studies show that various amounts of order and disorder can be produced in a given cellulose plastic by the quenching or tempering treatment.

Two other methods of controlling the number of organized and disorganized molecules have long been used as working procedures in the technology of cellulose plastics. The first is to control the shape of the cellulose ester molecules by the amount of the reaction and the nature of the substituting group so that they can only partially fit together to give an ordered array. By analogy, a few extremely fat men would cause the army squads to become locally disarranged, a desirable condition, at least in the plastic. The second, and

February 1942

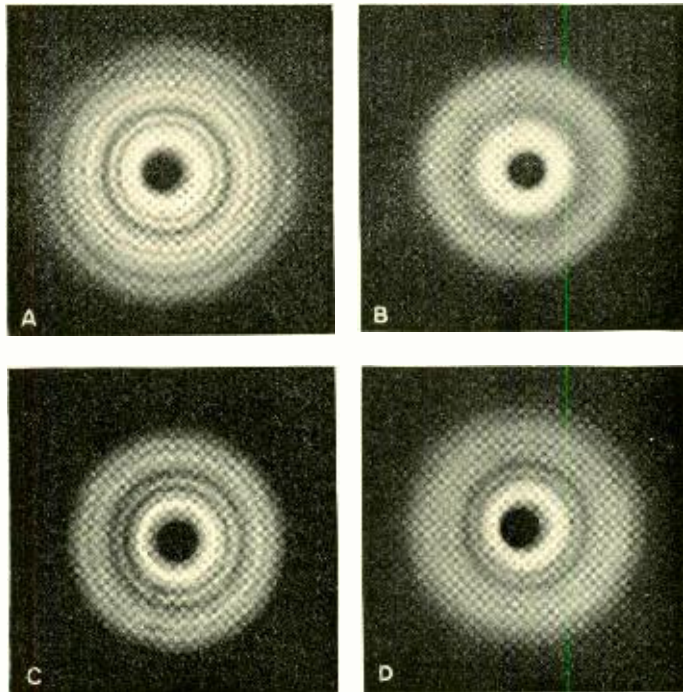

*Fig. 2—X-ray diffraction patterns of a cellulose ester: A, in highly crystalline condition; B, molecularly disordered; C, in partially crystalline state, obtained by annealing the specimen of B; D, similar partial crystallinity resulting from solvent action upon specimen shown in B*

this applies chiefly to lacquers such as airplane dopes and film formation, is selection of a particular solvent or mixture of solvents, which evaporates as the cellulose ester film dries. Various liquids were found to cause different amounts of molecular order in the resulting films. The analogy to the soldiers here is to imagine a company of them swimming about in a reservoir of water which is then drained so that the men settle toward the bottom. When they can finally stand there they may be found either disordered and facing in all directions or in intermediate degrees of organization, with some almost in parade formation. For the molecules, the degree of order in which the liquid leaves them has been found to depend

largely on the nature of the liquid. Hence arises the technical importance of choosing solvents so that the films will not crack off flexing wires or airplane parts.

An interesting detail of the study was proof that sections of the plastic's molecules could move around and "come to attention" in ordered positions in the solid state. The molecules in solids are generally regarded as being fixed but it is now found that

actually they undergo considerable torsional motion, under the influence of temperature. Thus, it was possible to anneal quenched cellulose esters, and x-ray patterns show how this process causes the chain molecules to take up ordered positions. This ability of portions of the molecules to move in plastic solids even at ordinary temperatures appears closely related to their plasticity and capacity to bend and return to the original form.

---

## CARRIER SYSTEMS HELP SAVE SCARCE MATERIALS

*Expanding production for defense is calling both for more telephone service and for lessened use of strategic materials. Hence the Bell System is drawing on the ingenuity and resourcefulness of its development and engineering organizations to sustain its expansion program.*

*An example is a project to permit placing more type-C carrier systems (top frequency 30,000 cycles) on many existing open-wire lines. Each type-C system provides three additional telephone circuits from a single pair of wires. On recently built lines, improved pole-head configurations and transposition designs have been employed and phantom circuits abandoned, so as to permit the use of type-C systems on all pairs of wires without incurring excessive crosstalk. However, the major part of the existing open-wire toll plant involves phantoms, and employs the "alternate arm transposition system" which permits type-C carriers to be applied only to the first and third crossarms of the line.*

*Recent developments in the Laboratories have now made it possible to add type-C systems to four pairs of wires on both the second and fourth crossarms of existing lines. New transposition designs have been worked out which require relatively inexpensive changes on the line and can be applied with little interference to working systems. Within the limited range available, two new carrier frequencies were selected so as to reduce crosstalk with existing carriers, and the necessary filters were designed. Advantage was taken of improved technique in inter-pair balancing for further reduction in crosstalk. By these means, existing voice-frequency phantom circuits can be retained, and twenty-four additional telephone circuits added to these older open-wire lines.*

*Some 175,000 pair-miles are potentially available for such retrans-  
portation and for application of additional type-C systems. Thus over  
500,000 additional miles of telephone circuits might ultimately be  
obtained. If all of those circuit-miles were to be provided by new open-  
wire construction, about 25,000 tons of copper and 5000 tons of steel  
would be required.*

## Temporary Protection for Cable Splices

By V. B. PIKE  
*Outside Plant Development*

rubber into which has been calendered a layer of unvulcanized rubber. This unvulcanized layer is quite tacky and simple contact of the two parts unites them securely. The tape is supplied to the field with a varnished separator calendered to the tacky surface to permit packaging in rolls and to protect it from contamination. One roll is enough for several splices.

In use a blanket large enough to surround the splice and ex-

tend a few inches over the adjacent lead sheaths is hung over the exposed conductors with the plastic side down. Pinching together the tacky surfaces of the overhanging edges forms a longitudinal seam and closes the blanket into a tubular covering. The ends are bound against the sheath with a tough rubber cord. To test for water tightness, nitrogen gas is forced at low pressure under the splice covering and after applying soap solution, the seam and joints are inspected for bubbles. Wrappings of friction tape or muslin outside of the tape reinforce the covering against disruptive gas pressures or other stresses. Half an hour suffices to make and test the new protectors on the largest cables, whereas a lead sleeve for a similar splice requires about three hours. With the new material cable splicers

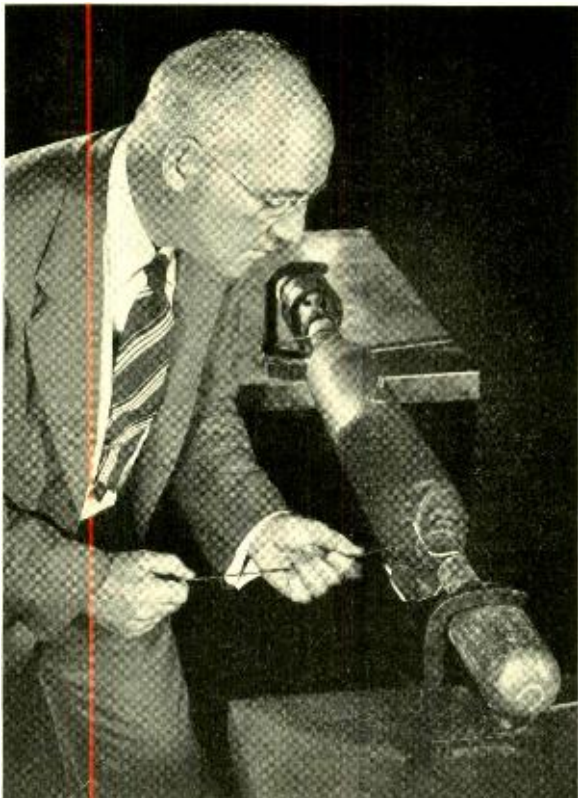

**W**HEN a splicer installs lead-covered cables he frequently reaches the end of the working day with an uncompleted splice in hand. At other times he may want to keep one open for days or even weeks for testing purposes. For protection when unattended, splices have to be sealed with water-tight coverings. Until recently the only reliable covering has been a lead sleeve which surrounded the splice and was soldered to the cable sheath. Lead covers are expensive because much of the working day is required to make and remove them.

A self-sealing rubber protector has been developed by the Laboratories for short-time application in place of lead sleeves. This CR tape is now being used in the field. It is composed of a layer of tough vulcanized

can use considerably more of their time for work of lasting benefit.

#### COVERING A STRAIGHT SPLICE

After the wires of a splice have been wrapped with muslin, the overall length to be covered and the maximum circumference are measured. A tape blanket is then cut larger than these dimensions to provide material for a butt seam along the length of the



splice; also to overlap the cable sheaths at the ends.

In the middle of the blanket a small circular hole is cut. Following this the entire varnished separator is removed in strips about four inches wide.

The separator strips are then laid back on the tacky rubber surface with

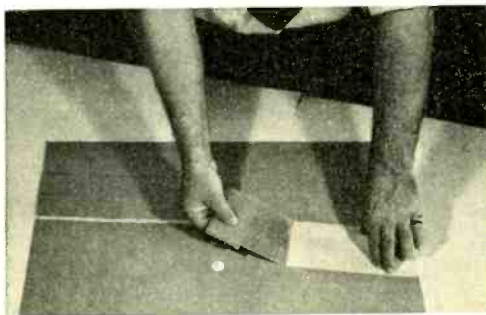

a small overlapping of the edges. This step is taken to protect the tacky surface and to permit easy removal of the separator in the restricted space of manholes. An air valve is passed

through the hole in the blanket and attached to the tacky rubber surface.

By folding the rubber with the varnished cambric on the inside it can

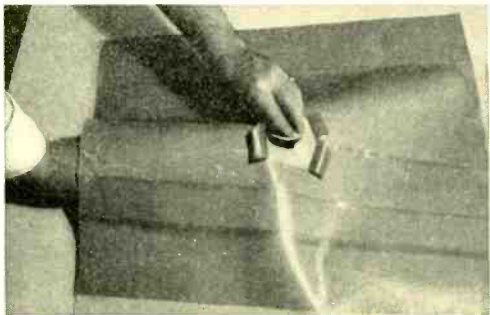

be handled conveniently and passed from one man of the splicing crew to another without danger of the tacky surfaces sticking or being contaminated by foreign substances.

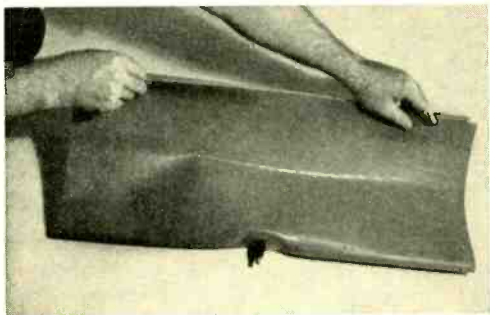

After the blanket has been centered over the splice with the tacky side down, the strips of separator are removed, leaving tacky rubber directly against the muslin-wrapped form.

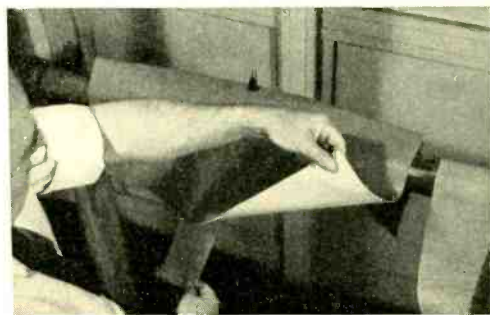



The parallel edges overhanging the sides of the splice are joined with a slight overlapping and the tacky rubber compound adheres to itself on contact. Closing the surfaces evenly against each other makes the seam.

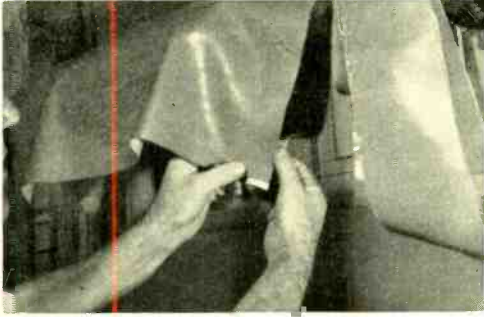

To assure a straight, even seam a slight tension is applied to the rubber as the edges of the blanket are brought together and joined.

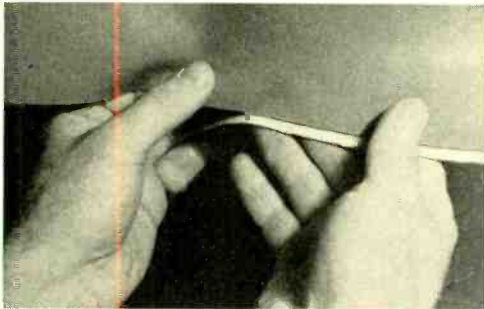

The seam is widened to close the blanket snugly and fins are formed to fit it about the cable sheaths. This operation is shown completed at one end and in process at the other.

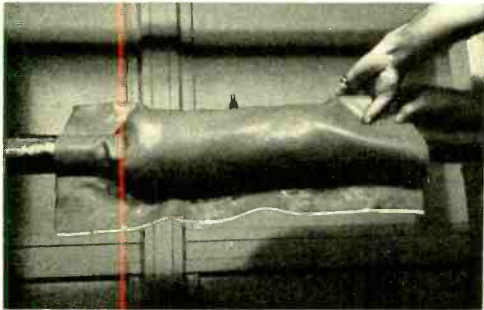

Excess material is removed by trimming the fins to a width of something like one and one-half inches.

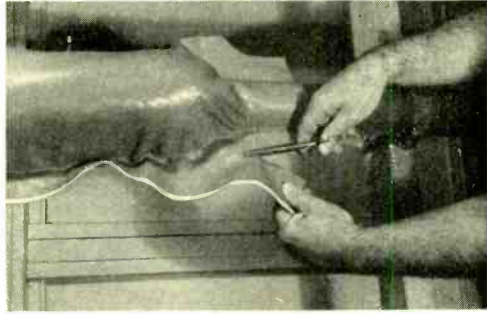

The ends of the rubber covering are bound tightly against the cable sheath with a tough rubber cord about  $\frac{1}{8}$  inch in diameter. The pressure causes the plastic non-vulcanized rubber to flow into all hollows and crevices, making a good seal to the sheath.

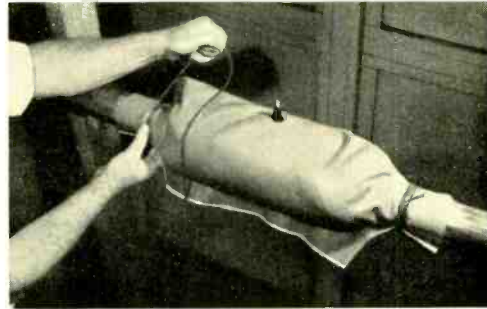

After filling the rubber covering with compressed nitrogen, all points where leakage might occur are coated with a soap solution and observed for the formation of bubbles.

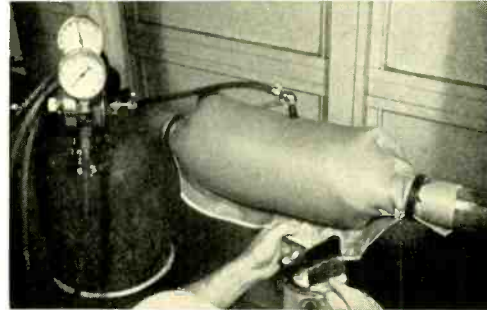

When the rubber covering has been found tight, it is reinforced with a wrapping of muslin. This safeguards the rubber against mechanical injury and supports the coverings on nitrogen-filled cables.



#### COVERING A BRIDGE SPLICE

Unlike some former coverings, CR tape protects bridge splices as reliably as straight splices. The initial preparation is the same as on a straight splice. After the cables of the "Y" end have been spaced about an inch apart, a strip of two-ply rubber is stretched through the crotch and the ends of the rubber strip are fastened under turns of the muslin wrapping.

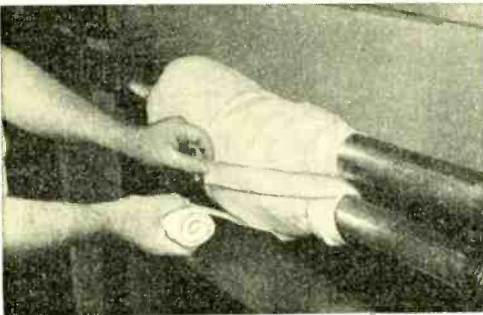

The blanket is then prepared and applied to the splice. A smooth web is formed in the space between the cables of the "Y" end by pressing the front and back layers together. The blanket is also attached to the piece placed previously in the crotch, thereby reinforcing the joint so that it

cannot tear open. The fins are then widened to make the material fit snugly about the sheaths.

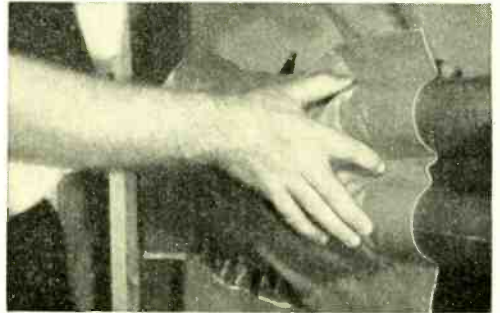

The web between the cables is cut, leaving an undisturbed portion about  $\frac{3}{4}$  inch wide.

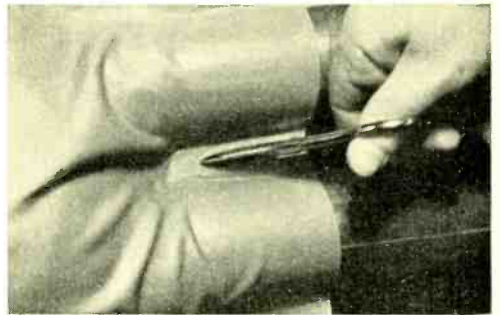

Binding each cable with rubber cord completes the waterproofing.



Muslin is wrapped over the covering after it has been soap tested. The hollows of the crotch are also packed with muslin and reinforced with a lashing of marline. The covering can then support the gas pressure maintained in cables.

# Lodgepole Pine Poles

By C. H. AMADON  
*Outside Plant Development*

THE traveler leaving Cheyenne, Wyoming, westbound on a morning plane is soon brought within sight of the great Rocky Mountain barrier that gave early pioneers so much of grief and hardship. Within the limits of his vision to the south and west and north, an almost unbroken expanse of evergreen forest clothes the middle slopes of the mountains. Among its several species of timber is one which has served those who have lived and toiled there ever since early Indian times; in fact its name came from the use of its slim saplings to support the buffalo-skin lodges in which the Indians lived. These "lodge poles" were young pines, later to become known as lodgepole pine. Its uses have been many within this region; the rails of the first railroads were laid on lodgepole pine ties, the first telegraph wires were hung on lodgepole pine poles, props made from the same timber supported the shafts and tunnels of gold, silver and copper mines, and pioneers built their cabins of it.

In the early days of the telephone industry in the Mountain States territory, northern cedar poles from the Lake States region and western cedar poles from the far northwest were commonly used because of their



proven durability in contact with the soil. None of the home-grown timbers possessed this quality, although lodgepole pine was known to be fairly long-lasting above the ground.

Early experiments showed that satisfactory durability could be imparted to the ground section of lodgepole pine poles by soaking the butts in creosote in open tanks, provided the soaking resulted in filling practically all of the sapwood with the preservative. The best of these old butt-treated poles have already served thirty years.

The controlling factors in butt

treatment are time, temperature of the creosote, and pressure. Time and temperature can be manipulated within limits fixed by the cost of treatment in relation to value of the treated poles in terms of years of service. Pressure in open tanks, however, is determined by the atmosphere. Experience eventually showed that the average results obtained by butt treatment left something to be desired; moreover, there began to be evidence some ten years ago that there would be need to draw on the lodgepole pine forests of the Rocky Mountains for poles to be used outside this territory in regions where conditions are more conducive to deterioration by decay. For those out-

pressure in excess of atmospheric pressure, and vacuum—can be added to the original factors of time and temperature. Control of the process is so greatly increased that results can be predicted; and, if not realized, reasonable inferences can be drawn in explanation of the failure.

To set the stage for development of a pressure-treating process it was necessary first to establish with reasonable accuracy the thickness of the sapwood which must be preserved against decay and the minimum amount of creosote per unit volume that should remain in the poles after treatment to provide satisfactory protection over a long period of years.

The thickness of sapwood of lodgepole pine varies over a fairly wide range, from about three-quarters of an inch to nearly three inches with an average of one and one-half inches. Based on the relation between the average thicknesses of sapwood of lodgepole pine and of southern pine, and the satisfactory behavior of the latter when treated to retain eight pounds of creosote per cubic foot of total volume, it was thought that half that amount should be satisfactory for lodgepole pine.

So there was the problem—how to adjust the tools of pressure treatment to produce, day after day, well-treated poles at a minimum cost. The objective was a composite one: depth of penetration by the creosote, one and one-quarter inches unless that depth was greater than eighty-five per cent of the sapwood thickness; amount of creosote retained, as close as possible to four pounds per cubic foot of total volume; finally, clean poles from which creosote would not exude after treatment.

The usual treating cycle, successfully used in pressure treatment of

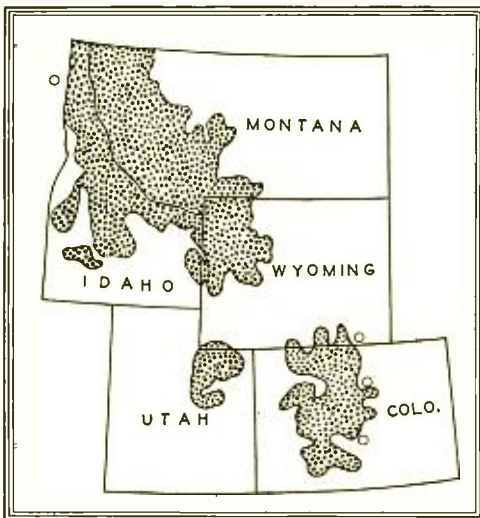

*Fig. 1—Extensive forests of lodgepole pine cover the middle slopes of the Rocky Mountains in the regions indicated by the dark areas on the map*

side regions full-length treatment would be required to protect the above-ground portion of the pole from decay. Because this treatment is most effective in closed cylinders an additional set of factors—namely

southern pine poles, failed, however, when applied to freshly cut or slightly seasoned lodgepole pine. Penetration by the creosote was unsatisfactory and the quantity retained was too great.

The results of treating partially seasoned and fully seasoned poles were somewhat more promising. The poles were subjected to impregnation under pressures up to 50 pounds per square inch which were maintained until about 7 pounds of creosote per cubic foot of wood had been forced into the timber. After removing the unabsorbed creosote from the cylinder, the air within it was evacuated by pumps until a vacuum equivalent to 24 inches of mercury at sea level was established.

That vacuum was expected to recover part of the creosote and leave about four pounds per cubic foot, but actually about five and one-half pounds per cubic foot was retained. The surface condition of the poles was entirely unsatisfactory; however, penetration, the most important of the desired results, was obtained.

Effect of the other variable, air pressure, was then investigated using partially and fully seasoned poles. Before filling the cylinder with creosote, the timber was subjected to a period of air pressure. This pressure was then maintained by means of control valves as the cylinder was filled with creosote. From this point on the process was the same as described: injection of about seven pounds of creosote per cubic foot, followed by

the final vacuum. The results were satisfactory penetration and retention, but again the surface condition of the poles was highly objectionable because of the exudation of creosote.

Apparently this was caused by en-

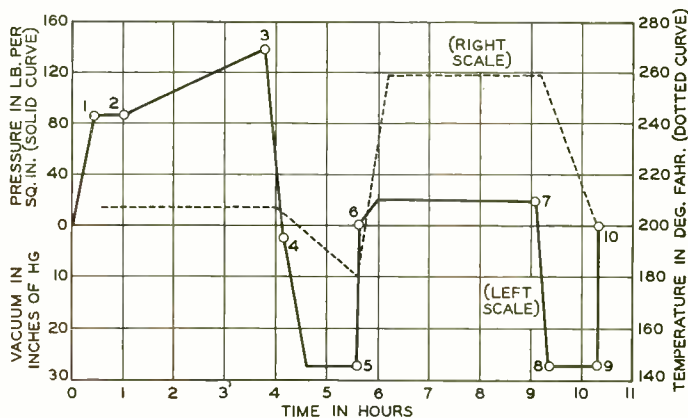

Fig. 2.—In creosoting lodgepole pine telephone poles they are put into cylinders and subjected first to compressed air; then to creosote under pressure; then to vacuum for recovery of excess creosote; then to live steam and a final vacuum to reduce further the amount of creosote and insure clean, dry, well-treated poles

trapped air slowly bubbling toward the surface, bringing creosote with it but leaving much creosote in a fairly thin outer layer. Thereafter under temperature increases within the wood induced by exposure to hot sun, the creosote expanded and continued to exude. Something had to be done to evacuate the creosote more completely before the poles were withdrawn from the cylinder. Prolonging the vacuum did not have the desired effect, apparently because cooling of the air and creosote in the wood slowed down the migration of the creosote to the surface. But if pressure and temperature were again built up in the wood and the poles subjected to a final vacuum it seemed reasonable that the excess creosote could be evacuated. The most practical means

available for raising the temperature and pressure within the wood was by application of live steam at about 260 degrees Fahrenheit.

Figure 2 shows the cycle finally adopted. After the poles are in place and the cylinder door is closed, compressed air is admitted until the pressure rises to about 85 pounds. Some of this air enters the cells of the wood. At 1, hot creosote is pumped in until the cylinder is full. At 2, more is pumped in until the pressure rises to about 135 pounds. During this period of nearly three hours the creosote is taken up by the wood and fills its cells. Air pressure is released at 3 and a vacuum is drawn at 4. Under evacuation, the entrapped air brings to the surface most of the excess creosote, which drips off and is pumped out of the cylinder. The vacuum is broken at 5, and live steam is admitted at 6. Pressure of twenty pounds and temperature of 260 degrees are maintained for three hours to reestablish

pressure in the wood and increase the fluidity of the remaining creosote. A vacuum is then drawn, 7 to 8, and held for an hour during which time more of the creosote comes to the surface and drips off. At 9 the vacuum is broken and the cylinder is opened, 10. Any liquid creosote on the surface of the poles is quickly reabsorbed, and the poles are reasonably clean.

The first charge treated by that process completely satisfied the three requirements. Successive experimental treatments served to establish minor modifications of the several steps. Approximately 50,000 full-length pressure-creosoted lodgepole pine poles have been treated according to the process described, with a high degree of conformity to the desired results in terms of penetration, consumption of creosote, and cleanliness of the poles.

The end result of this whole effort has been to make available a large new potential supply of poles.

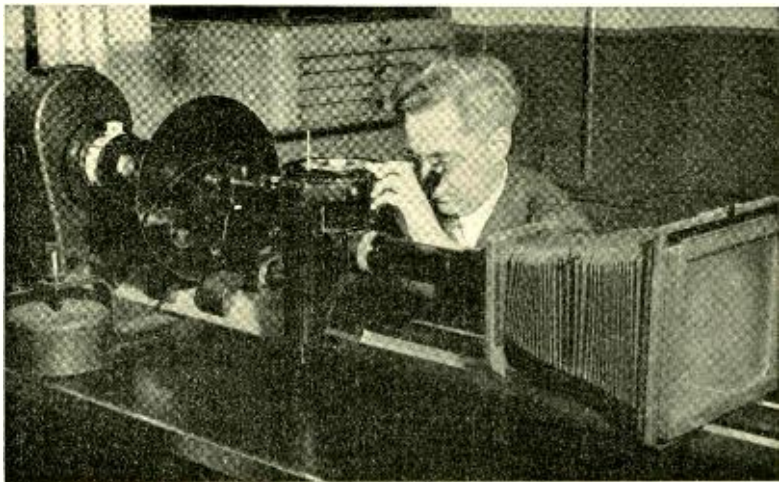

*E. E. Thomas using the latest type of metallographic microscope equipped with an anti-vibration mounting*

## Contributors to this Issue

W. O. BAKER received the B.S. degree from Washington College in 1935 and the Ph.D. from Princeton in 1938. He was a Harvard Fellow at the latter institution in 1937 and after receiving his doctorate he spent the following year there as Proctor Fellow in a study of solid dielectrics. Dr. Baker joined the Laboratories in 1939. He has worked since then on the physical properties and molecular structure of polymers and plastics used for molding and for wire insulation.

V. B. PIKE spent nine years with The Bell Telephone Company of Pennsylvania after his graduation as an Electrical Engineer from Lehigh University in 1917. He transferred to the Department of Development and Research of the AT&T in 1926 and to the Laboratories in 1927 when the Outside Plant Development Department was organized. Throughout his telephone experience Mr. Pike has been handling outside plant problems. Since coming with the Laboratories he has originated many features of the gas pressure system for maintaining lead-covered cables and more recently has been handling a number of problems con-

nected with joining lead-covered cables.

A. B. HAINES graduated from Virginia Polytechnic Institute in June, 1930, with the B.S. degree in Electrical Engineering. He joined the Laboratories in July of that year and has since been associated with the transmission apparatus development group. Mr. Haines has been engaged in the design and development of power transformers and associated coils for use in rectifier equipment for the telephone plant and for radio and sound-reproducing systems, in addition to recent development work on static-type tone apparatus for signaling purposes.

AFTER GRADUATING from the Biltmore Forest School, C. H. AMADON continued in the practice of forest engineering until he joined the Western Electric Company in 1917. He was there engaged in establishing standard inspection procedures and supervising inspectors of the timber products used in outside telephone plant. Mr. Amadon transferred to the Laboratories in 1925 when they were organized. As a member of the timber products group in the Outside Plant Development Department, he has had a responsible



*W. O. Baker*



*V. B. Pike*



*A. B. Haines*

part in setting standards for timber products and in the development of improved processes for preservation of wood.

P. B. MURPHY joined the Bell System in 1913 following two years of study at Baylor University. Until 1917, he was with the Southwestern Bell Telephone Company, where he served in various capacities. He then went overseas in the 412th Telegraph Battalion, and received his Second Lieutenant's commission in the Signal Corps. He returned to the Southwestern Company in 1919, but

shortly transferred to the Engineering Department of the Western Electric Company, where for some ten years he was with the Systems Development Department. In 1929 he transferred to the Electrical Research Products Corporation, where he later became manager of a division developing new lines of business. In 1936 he returned to the Laboratories, where again with the Systems Department he has been concerned with the development of program switching and voice-frequency key-pulsing systems.



*C. H. Amadon*



*P. B. Murphy*