

BELL LABORATORIES RECORD

DEC. 1945

VOL. XXIII

NO. XII

University of California
Division of War Research
at the U. S. Navy Radio and Sound Laboratory
San Diego, California

JAN 2 1946

JAN 2 1946

AN/TRC-6—A Microwave Relay System

By H. S. BLACK

Transmission Development

MANY of Bell Laboratories' secret war developments that played an important part in winning the war may also have valuable applications in modified form to civilian use, and will thus have doubly justified themselves. This is undoubtedly true of radio system AN/TRC-6, which was the only American-built microwave radio-relay communication system to see actual combat use by the Armed Forces. It is a combined radio transmitter and radio receiver with multiplex facilities for providing eight two-way message channels between two points over an unobstructed line-of-sight transmission path. Developed especially for the Signal Corps, it is a transportable military radio set capable of providing dependable and high-quality communications between fixed points. These sets can also be used in pairs as a radio relay, and it is practicable to operate a considerable number of radio relays in tandem without appreciably impairing the overall transmission. Because of the line-of-sight path

over which the system operates, the distance between sets is limited by the curvature of the earth, but by using intermediate sets as radio relays, communication may readily be extended to hundreds and even thousands of miles.

A highly directive and sharply focused microwave beam with a frequency of nearly five billion cycles per second is used to carry the intelligence of the eight messages. The antenna beam pattern is comparable in sharpness to that of a searchlight, and the five-billion-cycle radio frequency of the relay system corresponds to a wavelength that is less than one-half the length of an ordinary lead pencil.

This very high radio frequency gives communication channels virtually free from static and most man-made interference. As a result of the sharply beamed transmission, the correspondingly highly directive reception, and the absence of static and other external noise sources, a small amount of transmitter power is adequate for com-

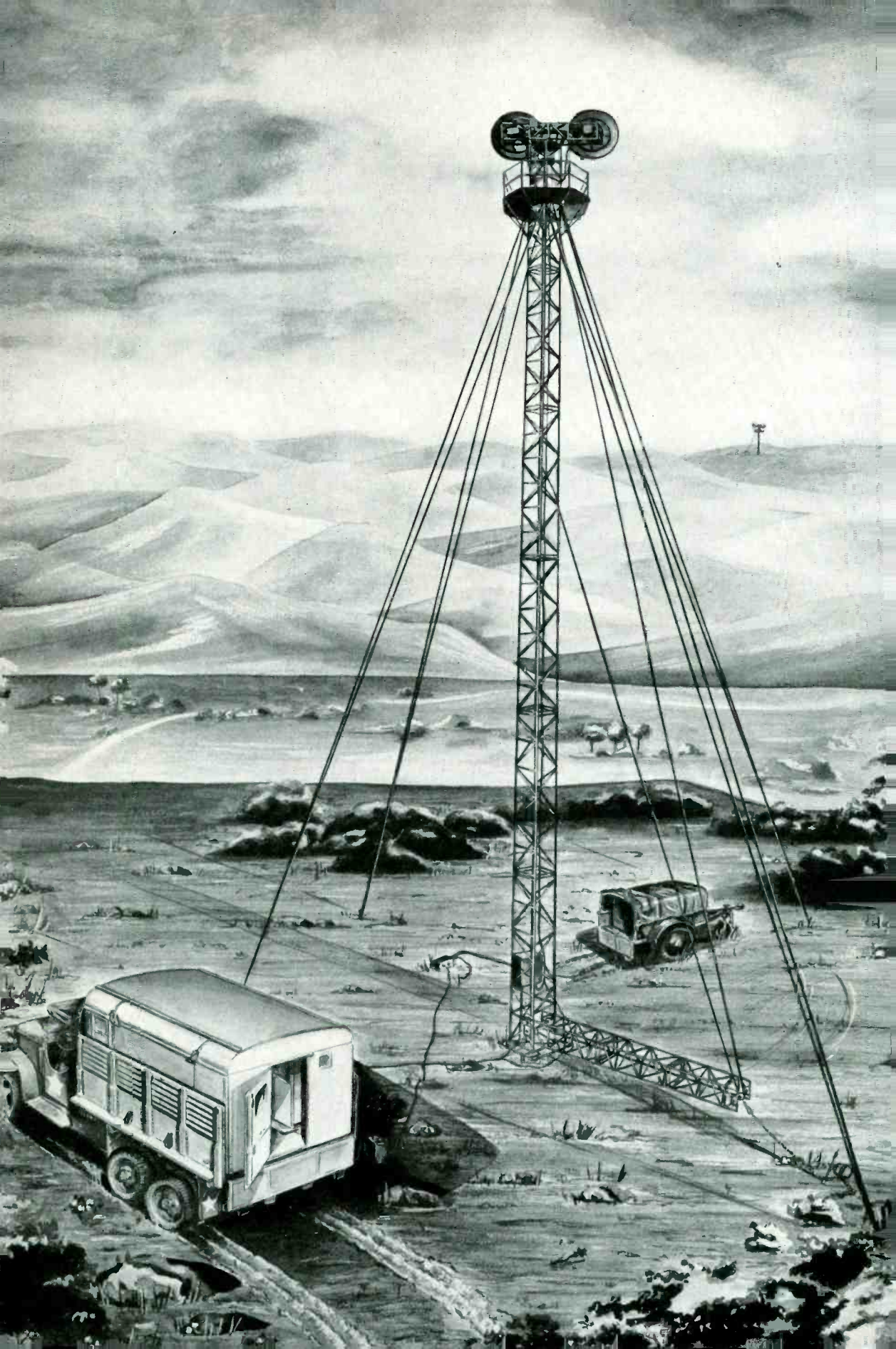

Microwave Radio Systems in the Bell System

Although the AN/TRC-6 was designed particularly for military use, its basic principles and design features are also applicable for use in providing telephone, telegraph and other communication services to the public. The AN/TRC-6 system is, in fact, only one of several microwave radio relay systems which have been and are being developed for the Bell System. These various methods will be used by the System for long distance transmission of telephone messages, television programs, sound radio broadcasting programs and any of the telephone facilities may be used to provide as many as eighteen independent telegraph channels. The extent of usage of each of these services will depend on its particular advantages.

Forward-looking plans of the Bell System contemplate improving and expanding its services by the best method available in each particular case, whether that be by radio, by wire, by coaxial cable, by other means, or by combination of any of them. Bell System scientists and engineers have pioneered the development of radio for telephone communications. Overseas radio-telephone service was opened to public use nearly twenty years ago. The Bell System operates radio-telephone service connecting thousands of ships and boats with the land telephone network; and it has for several years used point-to-point radio-telephone system as integral parts of the long-distance telephone network—usually to obtain direct routes over water barriers.

Pulse position modulation radio system comparable to AN/TRC-6 may first be used in the Bell Telephone network for the latter purpose—that is, to provide links between points separated by water. Meanwhile, as announced some time ago, the Bell System is proceeding under experimental licenses granted by the Federal Communications Commission to build another type of radio relay system between New York and Boston. The Bell System is, in short, exploring fully the use of microwaves as a supplement or alternative to wires and cables for telephone, telegraph, television and sound program transmission, and it will build radio relay systems into its nation-wide plant as rapidly as they prove their value in rendering dependable, economical communications service.

munication over optical paths of considerable distance. A peak power of two watts serves for jumps as great as 100 miles. Because of the sharp beam pattern of the transmitting and receiving antenna systems, because transmission must be over an unobstructed optical path, and because of the method of modulation employed, a substantial number of sets using the same frequencies may be operated in close proximity at a single location.

Unlike the conventional radio communications equipment, which transmits a continuously modulated wave as in an amplitude or frequency-modulation system, radio

The illustration on the opposite page shows the AN/TRC-6 as used in tactical movements with the operational units housed in a truck

set AN/TRC-6 makes use of what has been commonly called "pulse modulation." In such a system, the radio transmitter emits short spurts or pulses of radio-frequency power, individual bursts lasting for intervals of time as short as about one-millionth of a second. These short microwave pulses are substantially constant in both amplitude and frequency. Eight one-microsecond pulses, one for each channel, are transmitted in sequence 8,000 times a second.

The intelligence of each channel is conveyed by varying the time position of the one-microsecond channel pulses. The phrase "pulse-position modulation" (PPM) has been applied to this method. Eight channels share the operating time of the radio transmitter and receiver, each using them in turn. Such a sharing process utilizes a

multiplexing principle that, at least for telegraph, dates back to 1853, and for many years has been known as "time division." Pulse transmission therefore not only provides for position modulating the pulses but also permits multiplexing the channels by time division. Simultaneous two-way communication is provided by using different radio frequencies for the two directions of transmission. Directional separation is thus obtained by frequency separation or "frequency division," while channel separation is obtained by time division. No detectable distortion of the re-created signals in the final receiver is inherent in this method of transmission, nor is the system limited to only eight channels. This is the number required by the Army for this particular military set, but systems operating on the same principles could readily be designed to provide many more channels.

The eight two-way message channels provided by each AN/TRC-6 system, like any other telephone channels, may be individually terminated in either two-wire or four-wire connecting circuits. Each is a high-quality telephone channel, and meets Bell System standards of transmission. The individual message channels may be used, of

course, to transmit signaling, dialing, facsimile, pictures, or multi-channel voice-frequency telegraph. In the latter instance, a single message channel may provide as many as eighteen separate teletypewriter facilities. As provided for the Army, the AN/TRC-6 includes not only the radio set itself, but a full complement of testing equipment for maintenance purposes, and all of the equipment necessary to connect into a telephone switchboard, such as the necessary protectors; talking, monitoring and signaling circuits; and two and four-wire terminating sets.

Microwave propagation at frequencies approaching five billion cycles is subject to fading, as is transmission at lower frequencies, and observed diurnal and seasonal effects are evidence of a close connection between microwave propagation and local meteorological conditions. No evidence has been found that the presence of rain or snow in the transmission path causes serious increases in attenuation. Although the radio propagation may vary by very substantial amounts, the individual overall transmission stability of the eight message circuits is extremely good. This might be surmised since the magnitude of the pulses does not convey the intelligence of the message.

The first four development models were demonstrated and put through their final paces during the early fall of 1943, and formally delivered to the Signal Corps during the early part of November of that year. These four sets were thoroughly tested by the Camp Coles Signal Laboratory in a series of field trials covering a period of nearly two months. By the end of the year, a green light was given for the construction of eight pre-production sets.

These sets were built

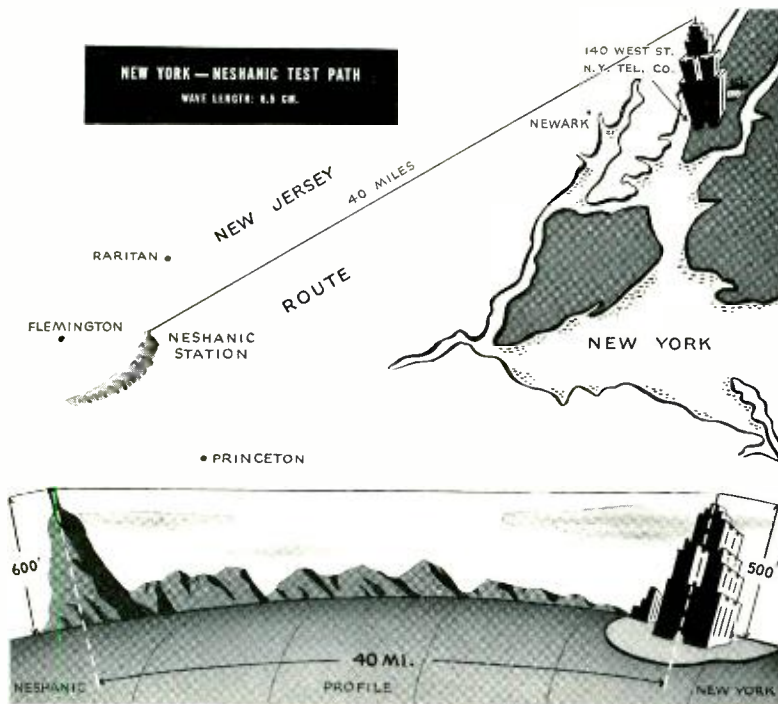



AN/TRC-6 antenna structures at Neshanic, New Jersey

by Bell Telephone Laboratories, and delivery started in July, 1944. Following their demonstration by the Army to high-ranking staff officers, all eight sets were used to form a 130-mile four-link system in Pennsylvania, with two terminals and three intermediate relays. As an Army Service Trial, this system was operated by troops twenty-four hours a day during the month of September 1944. An interesting check on the capabilities of the equipment was obtained by patching the channels in tandem to secure an 1,800-mile system. Voice-frequency telegraph and facsimile were also transmitted satisfactorily over the 1,800-mile channel. A more recent demonstration over long distances is described on page 480 of this issue.

Following the service trial, the troops who had been operating the sets were further trained by Laboratories' engineers at the Unit Training Center at Camp Edison. Subsequently, this group operated pre-production sets in the European Theater

of Operations. Meanwhile, the Bell Laboratories School for War Training conducted a course for a specially screened group of officers and men, which was followed by a series of additional classes given by the Radar School at Fort Monmouth. In this way, trained personnel were available for the operation of later production sets both in E.T.O. and the Pacific. The Western Electric Company also made available trained field engineers. For the Army, N.E.I.D. (New Equipment Introductory Detachment) undertook responsibility for the successful operation of the Western Electric production sets. During this period Western Electric Company was manufacturing the sets, and delivered eighty-four of them before the cessation of hostilities. For military reasons, each radio set as delivered contained not only duplicate operating units, but also sufficient spare parts for a year's operation without recourse to a supply depot.

An overall view of the external appear-

ance of the complete set is given in the accompanying illustrations. The antenna system includes a fifty-foot tower carrying two parabolic reflectors fifty-seven inches in diameter. As arranged for transportation, the largest components of the radio set are approximately 4 feet by 1 foot by 2 feet, and weigh 295 pounds. The complete equipment is usually carried in a 2½-ton truck. Because of its size and complexity, it is not intended for use in forward areas, but rather between Armies and Army groups and from Army groups to rear areas.

In the European Theater the sets had a short but distinguished career, and established a quick and vital means of communication; the fidelity of the facilities was reported superior to any other available means of communication. In a history of radio relay equipment issued by their Public Relations Office, the Signal Corps Engineering Laboratories wrote: "The equipment was introduced into the European Theater in December, 1944, and the response to its performance was most enthusiastic. The first installation in January, 1945, provided urgently needed telephone facilities between the 12th Army Group and Fifteenth Army. The first installation of AN/TRC-6 on the

east side of the Rhine was made shortly after the taking of the Remagen Bridgehead. An AN/TRC-6 installation was set up on a cliff on the east bank of the river only a few miles from the original crossing.

"When more equipment arrived in April, circuits were installed between the 12th Army Group and Third Army, and the 6th Army Group and Seventh Army. As the Third Army advanced into Germany, constant communication between it and the 12th Army Group was maintained by radio set AN/TRC-6, which was installed at each new location to which the Army moved. The last installation was made in the vicinity of Munich. The total distance by radio from the 12th Army Group near Frankfort, Germany, to the Third Army in Southern Germany was nearly 300 miles, and employed two terminals and three relay stations. A circuit of approximately the same length was installed from the 12th Army Group through the 6th Army Group at Heidelberg to the Seventh Army located approximately fifty miles northwest of the Third Army."

Radio set AN/TRC-6 has adequate transmission reserve to give satisfactory stable operation throughout fades commonly ex-

Three sets of AN/TRC-6 equipments in the "tank" room on the 32nd floor of the New York Telephone Building at 140 West Street



perienced over a fifty-mile optical path. Its operation over a considerable number of 75 to 100-mile optical paths is thus not surprising. When the Third Army shifted to Bad Tolz, a new route was selected on which the first radio path was a 99.5-mile shot straight down the broad Rhine Valley. Incidentally, there were three relays in this system, which was 277 miles long. When the Heidelberg system was extended to Augsburg by adding three relays, one of the jumps was 106 miles long. One end of this very long line-of-sight span terminated on the top of Zugspitze, Germany's highest mountain, which is snow capped the year 'round, and where there was twenty-seven feet of snow on June 26. There, the reflectors were regularly covered with from two to three inches of snow and ice, but transmission was unaffected.

In the Pacific, radio set AN/TRC-6 has seen limited use in Hawaii and in the Philippine Islands. In California, the Army recently successfully operated and demonstrated a six-link system over a distance of 510 miles—providing a number of two-way interconnecting circuits between San Diego, Los Angeles, and San Francisco.

From these practical applications, it seems probable that AN/TRC-6 equipment is the forerunner of future line-of-sight



In the German mountains the antennas of the AN/TRC-6 system operated continuously with several inches of snow and ice on them

microwave relay systems operating in the billion-cycle range which will provide stabilized broad-band communications facilities of high quality and dependability. These advantages are enhanced by sharply beamed transmission and reception, pulse transmission, and time division multiplex. Such systems can be transportable or fixed as required. The passage of time and the results of additional development which can be expected to follow at a rapid tempo will contribute toward establishing their economic status and advantageous fields of application.

THE AUTHOR: H. S. BLACK received the B.S. degree in Electrical Engineering from Worcester Polytechnic Institute in 1921, and at once joined what is now Bell Telephone Laboratories. In 1925 he was placed in charge of a group developing repeaters, regulators, filters, and other circuits for carrier telephone systems. Since then, carrier circuits, for both open-wire lines and cables, have attained the dominating position in the transmission of long distance calls. In connection with his carrier research, Mr. Black invented the stabilized feedback amplifier, which has come into general use not only with carrier systems but with radio broadcasting and other electronic and communications fields both here and abroad. He also proposed the use of thermostats for the regulation of telephone circuits.

In 1934 Mr. Black received the A.I.E.E. prize

for the best paper in Theory and Practice for his paper on *Stabilized Feedback Amplifiers*. In 1940 at the celebration of the 150th anniversary of the United States Patent System, he was honored by the National Association of Manufacturers as a Modern Pioneer, in recognition of distinguished achievement in the field of science and invention. In 1941 The Franklin Institute of Philadelphia awarded the John Price Wetherill medal to Mr. Black for his technical contribution to the modern efficiency of long distance telephony, particularly his development of the negative feedback amplifier.

Since early in 1942, Mr. Black has been concerned almost exclusively with secret war developments. One of the prominent of these projects was the AN/TRC-6 microwave relay system described in the above article.





The 6BP Audiometer

By A. H. MILLER

Acoustics Products Engineering

FUNDAMENTAL research in these Laboratories made possible not only aids for the hard of hearing, but also apparatus for measuring hearing ability with far greater convenience and accuracy than had been possible before. Although electrical audiometers, as is often the case with new developments, were rather slow coming into extensive use, they have for some years now been indispensable adjuncts to the otologist's equipment. The Western Electric 6A audiometer*—and its slightly modified successor, the 6B—have been widely used not only by physicians, but by hearing-aid dealers who found the audiometer an extremely valuable guide in fitting hearing aids to their customers.

With this widening use of the Western Electric audiometer, there has been a growing demand that the apparatus be put in more portable form

*RECORD, January, 1937, page 163.

so that physicians and hearing-aid dealers could readily carry it on visits outside their offices. Since the circuits and apparatus of the present Western Electric audiometers have proved very satisfactory, this need could be taken care of by making only those changes that would directly contribute to portability. The result is the 6BP audiometer shown in the accompanying photograph at the head of this article as it is used in making a measurement.

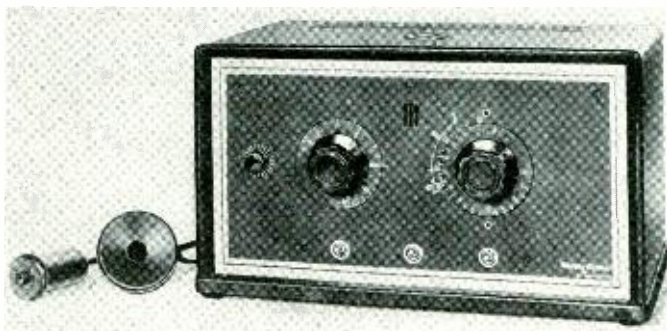

Fig. 1—The 6B audiometer is mounted horizontally in a rectangular case and has two operating dials



Fig. 2—The face of the 6BP audiometer is tilted up to facilitate operation

The 6B audiometer, shown in Figure 1, is housed in a small cabinet with two operating dials on its face. One of these adjusts frequency in the quarter-octave intervals from 128 to 9,747 cycles, while the other indicates the hearing loss in db. Losses from -15 to $+105$ db may be measured over the most important range of frequency. A test tone is provided by a heterodyne oscillator and a copper-oxide modulator that selects the difference frequency. Either an air or a bone conduction receiver may be used, and the patient indicates whether or not he hears the tone by a push button held in his hand, which controls a lamp on the top of the audiometer cabinet.

With this 6B audiometer, the chassis lies horizontally in its case, and the face plate carrying the controls is vertical. In the 6BP, shown in the photograph at the head of this article and in Figure 2, the same chassis is used but its front edge is raised about 2 inches, which tips the face plate backward at an angle of about 18 degrees. This makes the dials easier to read, and readability was further enhanced by finishing the face plate and dials in black instead of in brown, which was used for the 6A and 6B. This raising of the front edge of the chassis permits a 2-inch sub-panel to be mounted below it in which are mounted jacks for both the air-conduction

and bone-conduction receivers, a switch for selecting the receiver to be used for any particular test, and an indicating lamp that lights when the set is in operation. The power cord is also brought out through this sub-panel. With the earlier sets, both the power cord and the jack—only one of which was provided—were at the rear of the set while the pilot lamp was in the top. The second pair of jacks and the switch to select the receiver were added to simplify the operation of the set.

For this slightly modified assembly, an artificial leather-covered carrying case was provided with a removable front cover conforming to the slope of the face plate. A recessed handle in the top permits the set to be carried, and two vents give sufficient circulation of air to carry away heat generated in the tubes and the other elements. Two storage compartments are provided on the inside of the cover to hold the receivers, cords, index rings, and audiogram charts. The power cord is usually coiled around the two dial knobs before the cover is fastened in place. The push button by which the patient indicated whether or not he heard the tone is omitted from the 6PB, and the patient is asked to hold his index finger up as long as he hears the tone and to lower it when he fails to hear. This somewhat simplifies the set without decreasing its effectiveness.

THE AUTHOR: A. H. MILLER joined the Engineering Department of the Western Electric Company—now Bell Telephone Laboratories—in 1917, and most of the time since

then he has worked on train-dispatching and other apparatus for communications systems. He has also worked on many special projects, including a binaural system for the Navy in 1919, a mine control system for the Coast Artillery in 1927, and an aircraft carrier announcing system for the Navy in 1937. Since the present war began, a large part of his time has been on projects for Russia under lend-lease assignment.





Multi-Frequency Pulsing

By D. L. MOODY
Toll Switching Engineering

pulsing system was developed that sends out a-c instead of d-c pulses. The pulses are sent over the regular talking channels to senders usually located in the distant office, and since the frequencies employed are in the voice range, they are transmitted as readily as speech. The senders to which the pulses are sent must, of course, be arranged to receive this type of pulsing, and certain senders for the crossbar local and toll systems are so equipped. Existing local crossbar offices may readily be equipped to receive multi-frequency pulsing by adding the proper type of senders whenever conditions warrant the use of this system. The multi-frequency system does not take care of various supervisory signals, which must still be transmitted by other methods.

D-C KEY pulsing was developed some years ago to permit certain operators, such as those at toll and DSA positions, to transmit numbers to senders more rapidly than is possible with a dial. When this system is used, the operator is equipped with a ten-button key set, and she presses one button for each digit successively. With such key sets, the average speed of keying by the operator is two digits per second, which is about twice the average speed obtained with a dial, and this increase in speed results in a proportionately shorter work time. The first toll installation was in Detroit in 1930, but since then the system has been extensively used in many offices throughout the country.

Where this form of pulsing is used and how the circuits are arranged has already been described.* In all applications, it is necessary that the senders into which the pulses are sent be in the same office as the key sets. The system employs d-c signals to ground, and the presence of condensers, repeaters, d-c bridges, and repeating coils, as well as differences in ground potential, prevent its use directly on toll lines and trunks. To overcome these limitations, a multi-frequency

With the multi-frequency pulsing system, six frequencies spaced 200 cycles apart from 700 to 1,700, inclusive, are employed. Two, and only two, of these frequencies are used for each pulse, and each such pulse represents one digit. There are fifteen pairs of frequencies possible from a group of six, and ten of them are used for the digits from 0 to 9, inclusive, and one each for signals indicating the beginning and end of the pulsing. The remaining three possible pairs are available to meet future requirements. The various pairs of frequencies employed are wired to the key set so that, as each button is pressed, the proper pair of frequencies for that digit is sent over the line.

The first multi-frequency key pulsing system was installed at the toll board in Baltimore to permit the toll operators to complete calls for the local crossbar offices without the aid of another operator, or without requiring senders in the toll office. The development of the crossbar toll switching system, however, and the more extensive use of dial switching over toll lines that it presaged, indicated a much wider scope for multi-frequency pulsing in the future, and senders

*RECORD, November, 1943, page 110.

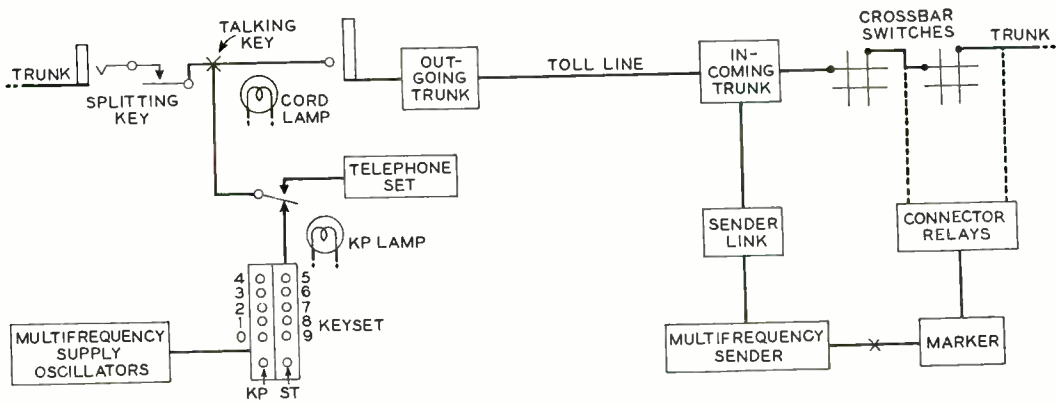

Fig. 1—Arrangement of multi-frequency pulsing between a manual No. 1 toll office, shown at the left, and a crossbar toll office, at the right

for the crossbar toll system were thus arranged both to send and receive this type of signal. Such senders transmit multi-frequency pulsing signals at the rate of seven digits per second, and thus once a number has been recorded in a sender, it can be rapidly transmitted to other senders. By installing multi-frequency pulsing equipment at the toll offices connected to Philadelphia by direct toll lines, therefore, any of these offices can directly set up connections through the Philadelphia office, and as more crossbar toll offices are installed in the future, this will become a common method of handling toll calls.

In Figure 1, a manual No. 1 type toll office equipped for multi-frequency pulsing is shown connected by a direct toll line to a crossbar toll office. When an outward operator at the manual board, which might be Baltimore, wishes to complete a call in a distant toll office, such as Philadelphia, she plugs into the line with her TALK key operated, waits until her cord lamp lights, indicating that a sender has been attached at Philadelphia, and then presses the KP (key pulsing) button of the key set. Prior to this, she has operated a "splitting" key to open the circuit to her calling trunk, and the operation of the KP button operates a relay that transfers her cord from her telephone set to her key set, and also sends a pulse consisting of frequencies of 1,100 and 1,700 cycles over the trunk to Philadelphia.

Receipt of this KP signal at Philadelphia prepares the equipment to receive the digits that will follow, and when this brief opera-

tion is completed, a key pulsing lamp in front of the operator lights to indicate that she may begin sending the digits of the desired number. The operator now transmits the called number—pressing one button for each digit. Following the last digit, she presses the ST (start) key to indicate she has finished sending. Besides informing the sender at the crossbar office that no more signals are coming, operation of the ST key

Fig. 2—Two signal supply circuits are mounted on a single panel for multi-frequency key pulsing

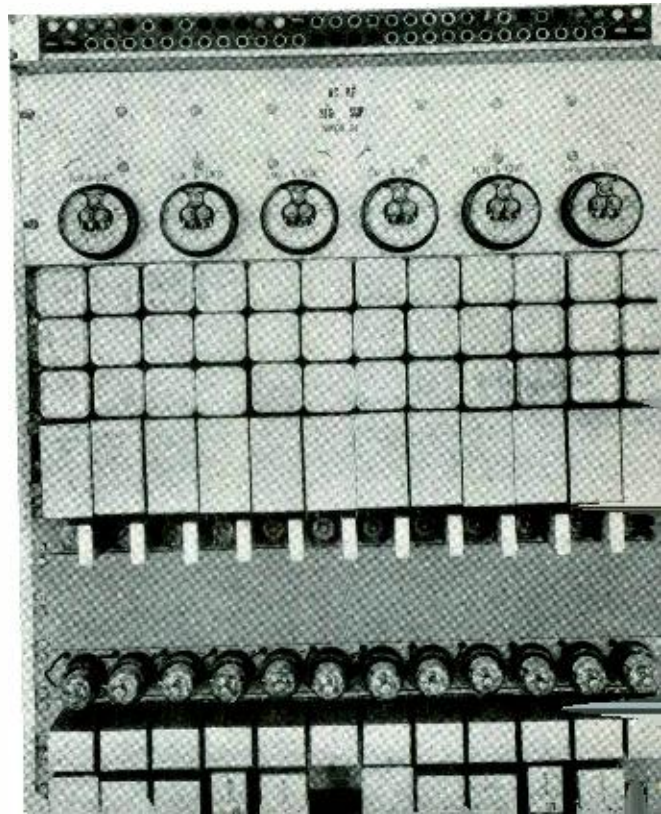

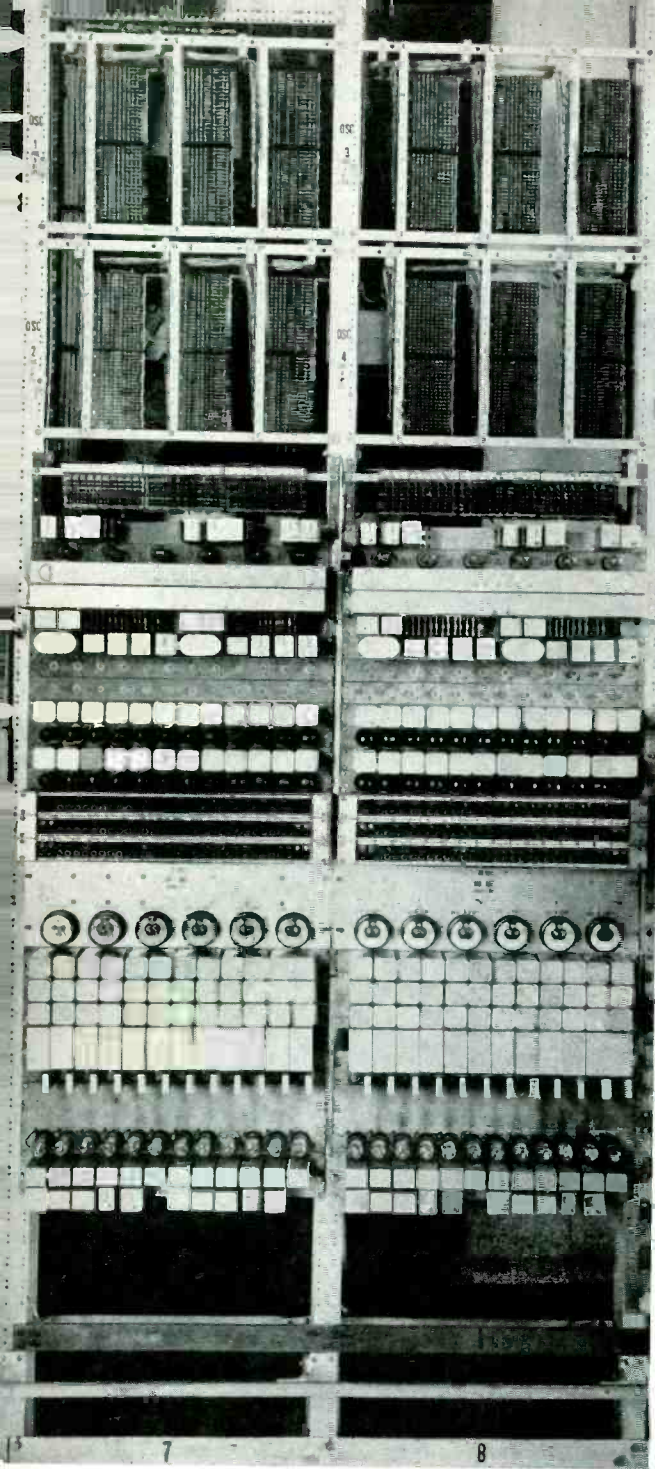

Fig. 3—Supply bays for multi-frequency key pulsing showing terminal punchings at top

also disconnects the key set and KP lamp from the cord, and reconnects the telephone set to the circuit.

When the called subscriber answers, the cord lamp goes out, indicating to the operator

that the connection has been established. If the called line is busy, if the connection cannot be completed because all paths to the line are in use, if the operator presses two keys simultaneously, or if she presses the KP key twice, the cord lamp flashes, and the operator must release the connection and start making the call over again in accordance with her instructions.

Besides the ten-button key set, two major circuits are required for the multi-frequency pulsing system: a multi-frequency supply circuit and a receiving circuit. The supply circuit includes six bridge-stabilized oscillators operating at the six frequencies from 700 to 1,700, inclusive. This type of oscil-

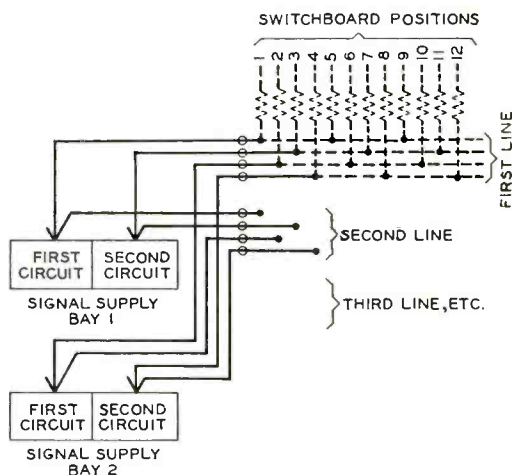

Fig. 4—Distribution arrangement to switchboard of the multi-frequency key pulsing supply

lator, which was briefly described in an insert in the RECORD,* holds both the frequency and amplitude constant with changes in load and supply voltage. This insures that the pulses sent are not only at the proper frequency, but that the amplitude of each frequency is approximately the same.

The primaries of twelve output transformers, one each for the KP and SR pulses and one for each of the ten digits, are connected across the outputs of the various pairs of oscillators, and the secondaries of these transformers are connected to the proper terminals of the key set. As each button is pressed, therefore, the proper pair of frequencies is sent over the line.

*January, 1940, between pp. VI and VII.

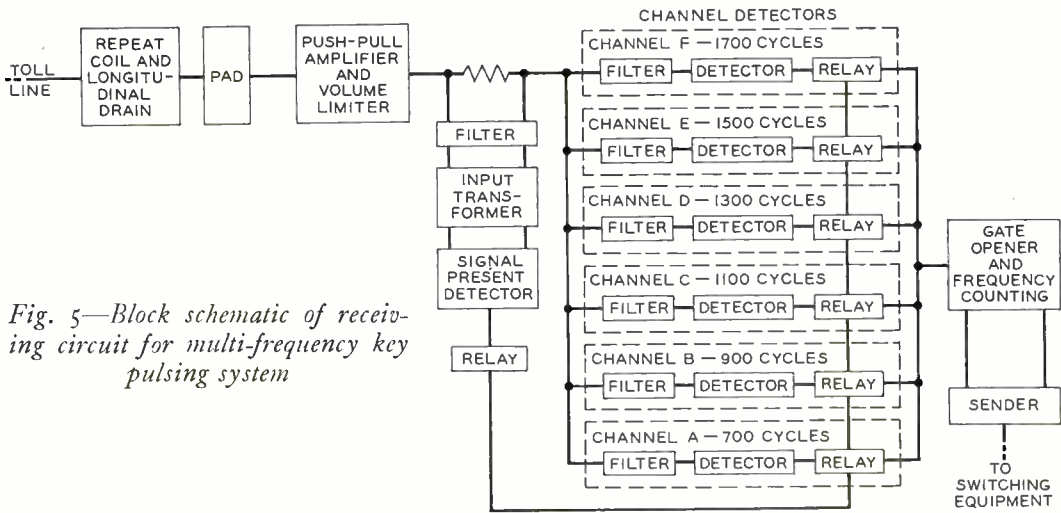

Fig. 5—Block schematic of receiving circuit for multi-frequency key pulsing system

Two of these supply circuits are mounted in a single bay as shown in Figure 2. Near the top of the bay are six voltmeter relays used with the voltage alarm. Four supply circuits are provided for each office, and thus trouble on any one of the circuits cannot affect more than a quarter of the switchboard positions. Trouble in the oscillators is very rare, however, and when it does occur, the positions affected are automatically transferred to the other supply circuit on the same bay.

Distribution of the supply to the various positions of a large switchboard is arranged as shown in Figure 4. Each position is supplied through individual resistances which are of such a value that a short circuit at any one of the positions will not overload the oscillator or affect the operation of the other positions. To care for the occasional cross which may occur on the leads between the

supply panel and the switchboard, a current alarm circuit is provided. To facilitate clearing the trouble, terminal punchings and straps are conveniently arranged at the top of the supply bays by which individual lines of switchboards can be readily isolated. These are evident in Figure 3, which shows a pair of supply bays complete.

For supplying senders or small switchboards, individual sets of leads are run directly from the supply panels to the senders or switchboard positions, and the protective resistors are placed at the supply panel. Because trouble in the supply leads under these conditions can affect only one sender or position, no current alarms are required in such installations.

The receiving circuit is shown in Figure 5. Stripped to its essential elements, it includes a repeating coil, a volume limiter, a signal-present detector circuit, six channel filters, six channel detectors with their associated relays, and a gate-opener and frequency-counting circuit.

The repeating coil reduces the effect of longitudinal currents that might falsely operate the circuit. The volume limiter is a combination amplifier and limiter that maintains the strength of the received signals within narrow limits. From the limiter, the signal divides two ways: one delivering energy to a detector used to indicate whether or not a signal is present; the other to a parallel arrangement of six band-pass filters, each connected to the input of a vacuum tube detector to operate the detector relays.

Fig. 6—A multi-frequency key pulsing receiving circuit

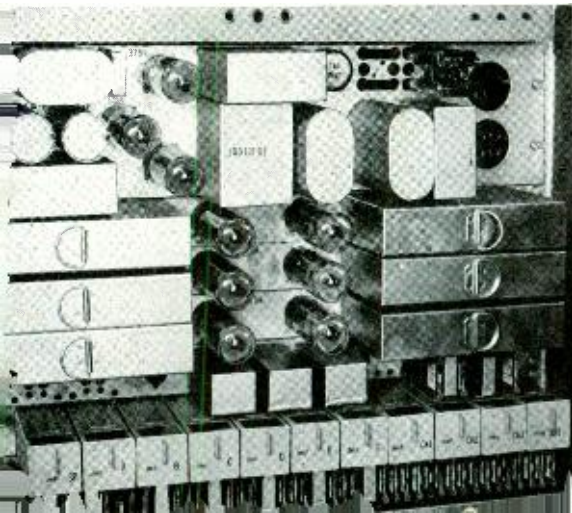

The filters have pass bands about 100 cycles wide centered at one of the six frequencies of the supply circuit, and are designed to step up the voltage applied to the detectors about 20 db.

Polarized relays are used to transmit the signals from the detectors to the sender. One of the windings of each relay is connected to the plate circuit of its associated detector tube, and current through this winding normally holds the relay unoperated. When a signal is received, the signal-present detector relay passes current through another winding of the polarized relay that tends to operate it, but that is incapable of doing so with full current through the first winding. Soon after the signal is received, however, a

negative bias has been established on the grids of two detector tubes by the action of the current through the bandpass filters, and with the resulting reduction in plate current, the relays associated with these tubes at once operate. Since each signal consists of two frequencies, two of the channel relays will operate on each pulse and pass indications to the sender to operate the proper register relays. The gate opener and frequency counting circuit completes the path from the receiver to the sender for registering the digits.

This, in brief, is the operating procedure of the receivers, but to insure satisfactory operation under all conditions, a number of other features are included. If the first pulse received does not consist of frequencies of 1,100 and 1,700 cycles, indicating a KP (gate-opener) pulse, no connections are made from the detector relays to the sender, and digits cannot be registered in the sender. If the KP signal is repeated, or if more than two frequencies are received for any pulse, appropriate supervisory signals will be returned to the calling operator so that she may pull down the connection and set up the call anew. To insure that the sender will register the digits even with the most rapid keying by operators, the detector relays are locked operated on each digit until the sender equipment signals the receiver that it is ready for the next one.

One of the receiving circuits is shown in Figure 6. The six detector tubes are evident near the center of the panel, while the two tubes for the volume limiter and one tube for the signal-present circuit are above and to the left of them. The six detector relays are those marked A to F, inclusive, along the bottom row, where are also other polar relays used in the circuit.

THE AUTHOR: DWIGHT L. MOODY, A.B. Harvard 1918, served in the U. S. Naval Reserve for



two years in World War I. As a Lieutenant (jg), he was engaged in the mine laying operations of the North Sea Mine Barrage. On his release from the Navy, he spent six or seven months with the New York Shipbuilding Company and then returned to Harvard for engineering studies.

In 1921 he received the B.S. degree in engineering and at once joined the Toll Equipment Engineering section of the D and R of the A T & T. From 1927 to 1934 he was in charge of the application of machine switching methods to toll circuits and equipment. Transferring to the Laboratories in 1934 with the D and R, he has since been in charge of such projects as toll line dialing and multi-frequency pulsing.

Pigment Dispersion in a Synthetic Rubber Latex

By W. McMAHON
Chemical Laboratories

THE usefulness of most synthetic rubber compounds depends largely on the reinforcing fillers or pigments in them. Without filler the physical properties of GR-S, the synthetic which is now being manufactured in large quantities for military and civilian uses, would be decidedly inferior to those of natural rubber. Fortunately, these properties can be greatly enhanced by compounding the GR-S with reinforcing fillers, especially carbon blacks. These pigments are usually dispersed in the rubber compound on mixing rolls or in a mixer with rotating knives. It has been found that the reinforcement obtained with a given pigment is proportional to the degree of its dispersion in the mixture. A process developed by the Laboratories accomplishes better dispersion of pigments in the polymer than that obtained by the usual mixing techniques and their effectiveness is thereby increased.

A study of the pigments used in GR-S indicates that the size of their particles has a marked effect on their reinforcing properties. Fine carbon blacks yield the greatest reinforcement as measured by ultimate tensile strength. There are exceptions, however, and consideration of the chemical and physical characteristics of those materials which do not follow the general rule led to the conclusion that they were not properly dispersed. Accordingly, a better means than milling was sought to disperse fillers in GR-S.

It was known that excellent dispersions of pigments can be made in water with the aid of dispersing agents; also that the polymer particles in GR-S are very finely divided—less than one-tenth of the diameter of particles in natural rubber latex. If, then, a water suspension of well-dispersed pigment was mixed with latex and the filler

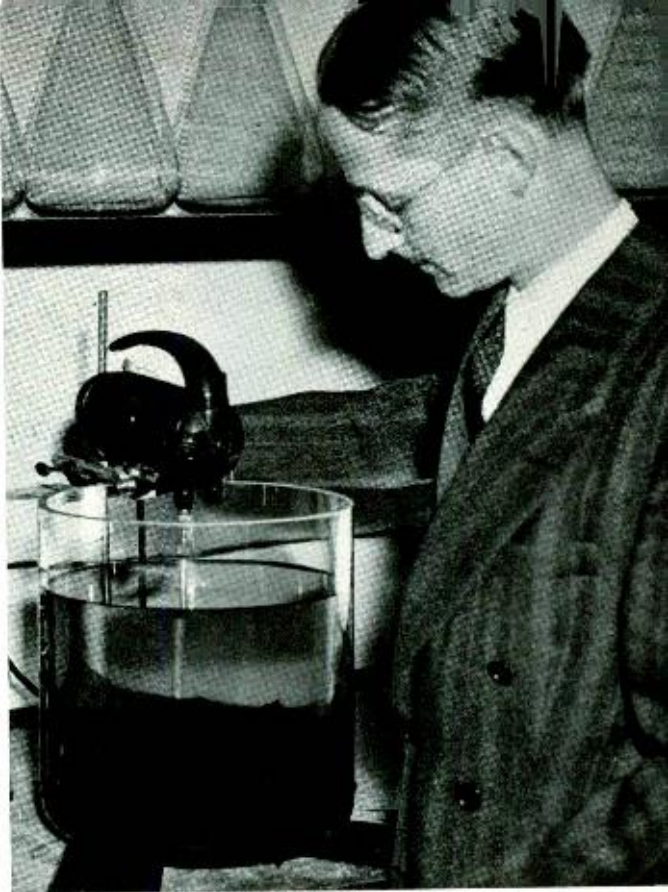

and polymer were precipitated or coagulated simultaneously, it was thought that the pigment might be more thoroughly dispersed in the polymer than it would be through dry milling. The physical properties of compounds made in this manner should show improvement over those mixed on a mill.

A practical method was devised for incorporating reinforcing pigments in GR-S polymers while in the latex stage. A high degree of dispersion is attained which is reflected in compounds with physical properties considerably better than those of identical compounds made on a mill.

The pigment was dispersed, with the aid of a colloid or ball mill, in water which contained a dispersing agent. A concentrated slurry was prepared and then passed through the mill until the pigment was thoroughly dispersed. This slurry contained from five to ten volumes of pigment per hundred volumes of water, depending on the fineness of the pigment—the finer the size of the particles the smaller the volume of pigment required. The thoroughness of the dispersion is important and can be determined with an ultra microscope. This slurry was then

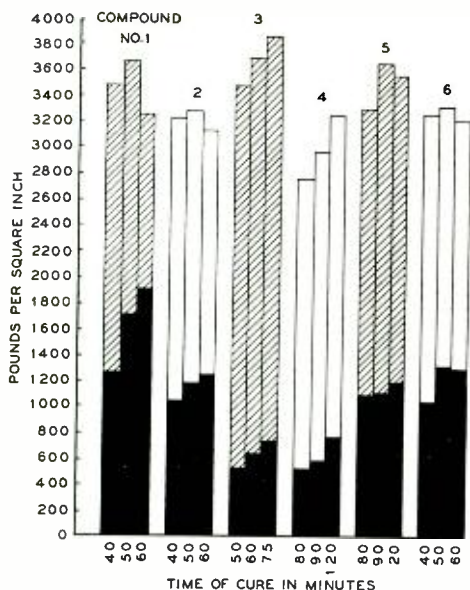

Fig. 1—Tensile strength of GR-S synthetic rubber compounds (1, 3, 5) made with latex-dispersed carbon black are superior to those (2, 4, 6) in which the filler is mixed on a mill. Black areas show tension required to produce 300 per cent elongation

diluted with an equal volume of water and thoroughly mixed with an amount of GR-S latex that contained the weight of polymer which would yield the desired ratio of pigment to polymer.

The mixture was coagulated with dilute sulfuric acid or alum solution. As the coagulant was added, a porous mass of polymer and pigment formed which broke into a fine crumb with continued addition of reagent. The crumb was filtered and washed free of water-soluble impurities. This material can be repulped readily while wet and washed with hot water to aid in removing impurities. After drying at 70 degrees C., the master batch was ready to be compounded with sulfur and accelerators.

Master batches prepared with carbon blacks, zinc oxides and calcium carbonates of different particle fineness were made by this process and compounds were prepared with them for measurement. For comparison, compounds of the same recipe were made by dispersing the pigment on a mill.

The stress-strain properties of the latex-dispersed stocks made with carbon blacks,

Figure 1, are better than those of mill-dispersed rubbers. Hysteresis values of compounds one and three compared with those of two and four indicate that the heat developed in latex-dispersed stocks should be lower than that of those mill dispersed. This order is reversed in compounds five and six. Comparison of the rate at which cuts grew in compounds five and six with flexing showed that the latex-dispersed material is also superior in this respect.

Compounds made with fine, medium and coarse zinc oxide were tested and show, Figure 2, that the stress-strain properties of the latex-dispersed compounds are markedly better than those mill dispersed. The hysteresis of the former is also low, which is another indication that the heat developed in the latex-dispersed stocks should be less than that in mill-dispersed mixtures. Electrical properties of compounds five and six were measured and are shown in Figure 3. Those of the mill-dispersed compounds were initially better but during immersion in water they declined more rapidly than did those of the more stable latex-dispersed samples.

To typify the improvement obtained by dispersing whittings in GR-S, compounds were made with extra fine, fine, and moderately

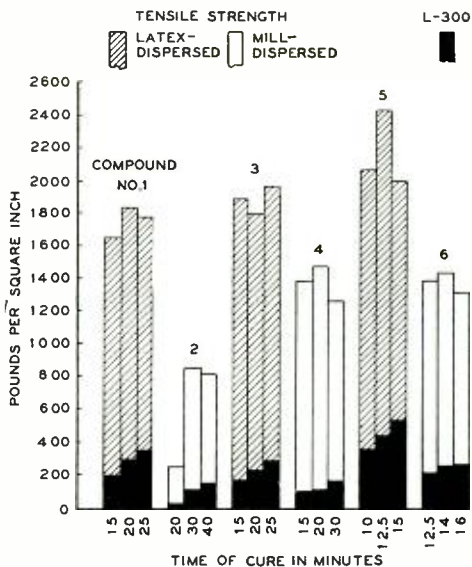

Fig. 2—GR-S compounds made with latex-dispersed zinc oxide have more tensile strength than mill-mixed samples

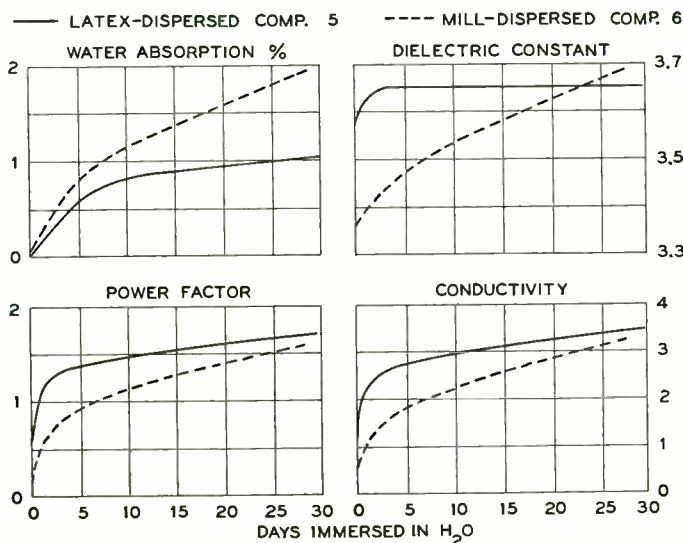

Fig. 3—Electrical properties of latex-dispersed zinc oxide compounds of GR-S, when immersed for long periods in water, are more stable than those mill mixed

fine size particles of this material. Figure 4 shows a substantial improvement in stress-strain characteristics results compared with those of mill-dispersed compounds. Furthermore, Figure 5 indicates that the electrical properties of latex-dispersed whitening compounds are superior in all respects to those of the same compounds dispersed on a mill.

The mill-mixed controls used for comparison were carefully prepared in the laboratory. It is unlikely that physical properties as good as these would be obtained in the factory. On the other hand, a latex master batch in which the pigment is already well dispersed should yield compounds in the factory with physical properties substantially as good as those of a laboratory-prepared stock. It is generally recognized that sulfur and accelerators are less difficult to disperse in the polymer than is the pigment. This was substantiated by a

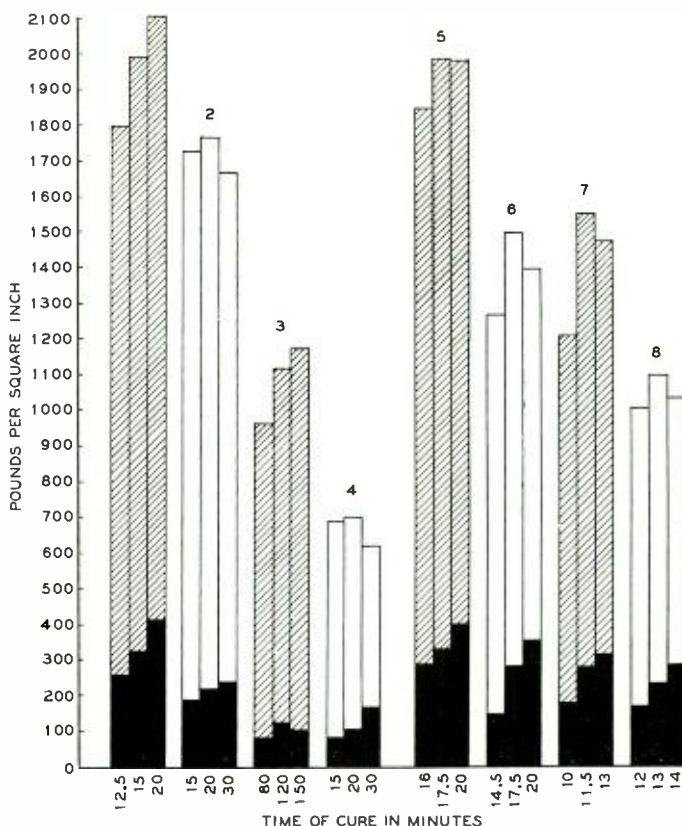

Fig. 4—Tensile strength of latex-dispersed calcium carbonate compounds of GR-S surpasses that of mill-mixed samples

These experiments show that insulating stocks, particularly those other than black, can be made which have physical properties considerably better than are obtainable by present methods. Improvement may also be expected in automobile tires and one tire manufacturer already has inaugurated this process in a synthetic rubber plant. Another advantage is cleaner handling in the factory, since no dusting of pigment occurs when it is master batched in the polymer. Incorporation of pigment in the latex stage may also prove to be more economical than mill dispersion. The saving of power in the manufacturing process and the increase in productive capacity of a factory unit, which is effected by shortening the time required for milling, may more than offset the cost of the latex pigmentation process.

THE AUTHOR: In 1926 W. McMAHON entered the Laboratories as a Technical Assistant in the analytical laboratory in the Chemical Laboratories. After about a year he joined the group studying wood preservation in that department and is now in charge of research on the preservation of wood and textiles. The work reported in this paper was undertaken as a special job, outside his regular activities, when the synthetic rubber program first got under way. Mr. McMahon attended the Brooklyn Polytechnic Institute at night where he received the degree of B.S. in Chemistry in 1942.

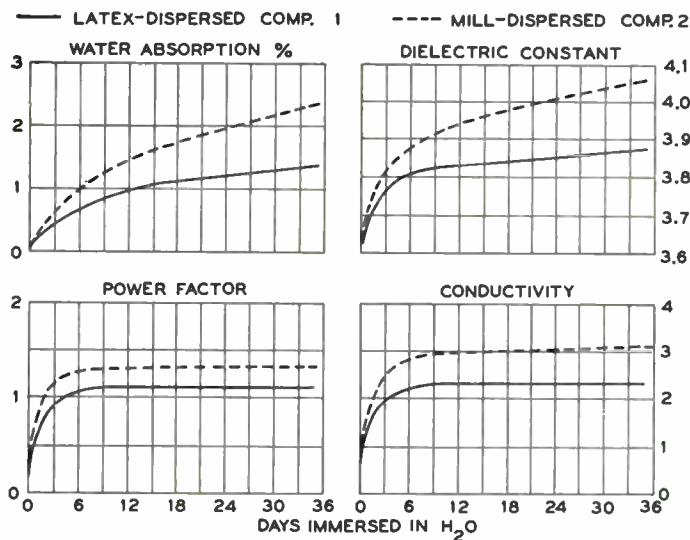
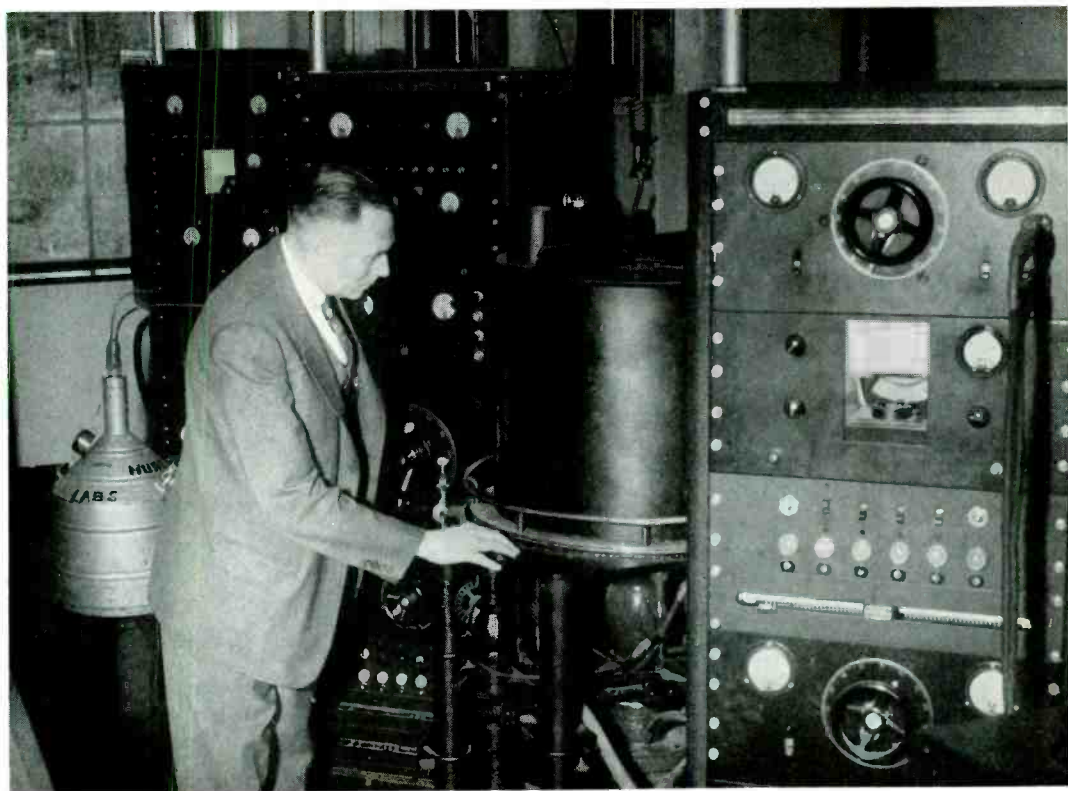

Fig. 5—Electrical properties of latex-dispersed whiting compounds of GR-S are superior to those mixed on a mill



Quartz Crystal Plating

By H. G. WEHE
Chemical Laboratories

TO SECURE better electrical coupling to their surfaces, quartz plates for certain applications are plated with some metal such as silver, aluminum, or gold. Plating has been used commercially on low-frequency crystals for a number of years. More recently, plating techniques have been applied to the high-frequency crystals, resulting in increased efficiency and less consumption of quartz. Plating, however, is an old art, and there are various methods by which it may be accomplished. A large amount of work has been required to determine the method that would most satisfactorily meet all the requirements of this particular application.

When the object to be plated is a non-conducting material, and a thin film of metal is desired, plating is usually accomplished either by deposition from a solution,

by spraying with molten metal, by baking on a metallic liquid or paste, by chemical decomposition of gases at high temperature, or by one of the many forms of vapor plating. With most of these methods, it is difficult or impossible to avoid contamination of the deposit by other elements. Vapor plating in some form usually makes possible a purer coating, and thus this method was adopted for plating quartz. Intensive studies were made to determine the effects of various factors involved. As a result of this work, vapor plating apparatus was developed and made available to the Western Electric Company a few years before the present war. The use of plating has been greatly increased by the enormous demand for crystals for war use, and the availability of carefully designed vapor plating apparatus has helped to maintain the high

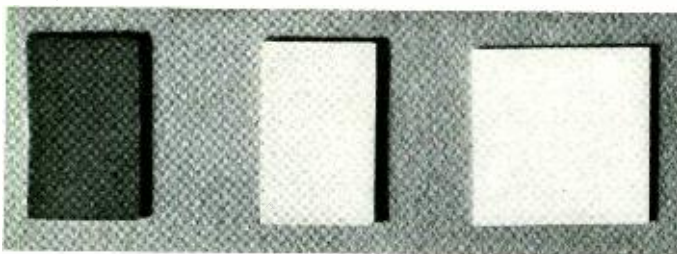

Fig. 1—Effect of pressure on the plating process. Crystal at the left was plated at 2×10^{-2} millimeter of mercury; the center crystal at about 7×10^{-4} millimeter; and that at the right, at about 2×10^{-5} millimeter

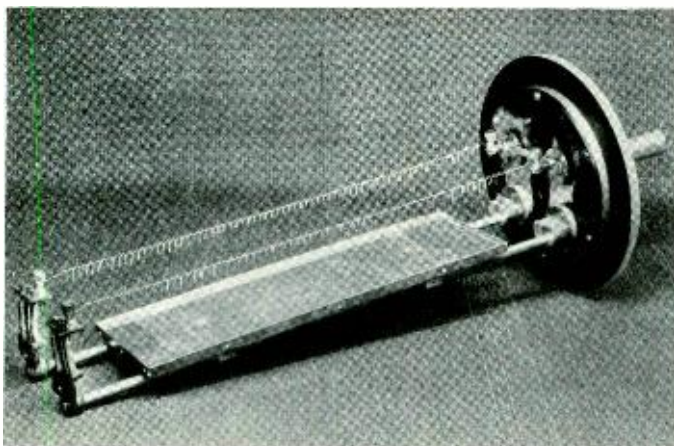

Fig. 2—Tray carrier and heating filaments for vapor plating machines. A complete machine is shown in Figure 3

standard of Western Electric quartz plates.

In plating by vaporization, the object to be plated is placed in proximity to a molten mass of the plating metal, and the vapor given off by the liquid metal strikes and adheres to the surface being plated. The process is preferably carried on in a vacuum, since the presence of air or other gas in the plating chamber may result in oxidation at the high temperature of the molten metal. In addition, molecules of the gas will be carried to the plating surface by the stream of metal vapor, and will mix with the metal molecules to give an impure and porous deposit. By carrying on the plating in a high vacuum, a deposit is built up atom by atom, and becomes a compact layer of pure metal. Other variables being held constant, vapor deposition is much faster in a vacuum than at atmospheric pressures.

One effect of the air pressure under which

the plating is carried on is evident in the appearance of the plates, as may be seen from Figure 1. Plating conditions for the three plates shown were alike except for the pressure. For the plate at the left, it was 10^{-2} millimeter of mercury. For the center plate, it was 7×10^{-4} millimeter, while for that at the right, it was about 10^{-5} millimeter, or approximately one hundred-millionth of atmospheric pressure. The plating at the left will readily smudge off, and only that at the right has a bright, hard surface.*

In the vacuum vapor plating apparatus developed by the Laboratories, the plating chamber is a cylinder about 5 inches in diameter and 18 inches long. These cylinders, open at one end, are placed in a horizontal position. Round cover plates for the open end have a gasket to give an air-tight seal, and carry two rods on which rests a tray for the crystals to be plated. The arrangement is shown in Figure 2. Two tung-

sten or molybdenum wires, coiled and stretched to form a chain of open loops, are fastened to the cover at one end and to supporting members attached to the ends of the horizontal rods at the other.

The plating metal as used with the first production machine was in the form of short fine wires that are hung over the tungsten coils at regular intervals and pinched together with tweezers to secure intimate contact with the heater filament. In later production machines, a continuous winding of silver wire on a molybdenum filament is used. When current is passed through the heater coils, the plating wires melt and draw up into drops that hang from the bottom of

*Since the preparation of this article, the author has successfully devised experimental techniques and equipment for vapor plating bright metallic firmly adhering films at atmospheric pressure instead of in a vacuum.

the loops of the tungsten coils until they evaporate. The supports for the heaters at the ends of the rods carry a set of four coiled springs that are tipped backward before the tungsten coils are fastened to them. The tension of the tungsten coils pulls them forward and the springs, in turn, by maintaining a tension in the coils, hold them horizontal as they tend to lengthen during electric heating.

One of the major problems that had to be solved in devising a proper plating procedure was how to secure a uniform deposit of the desired thickness. The problem is obviously complex, since temperature, pressure, the length of the plating period, and the position of the quartz plates relative to the molten metal, all enter as factors, and many of these factors have several effects. Thus, pressure, for example, will affect both purity of the deposit and plating time. The temperature must be high enough to melt the metal and maintain a steady stream of vapor, but if it is too high, the plating may proceed so rapidly as to produce a coarse-grained and uneven deposit. The time required obviously depends on all the other factors. Only extensive study and experiment will yield the best combination of all factors.

The best distance of the crystals from the plating metal is affected by several factors. The shorter the distance, the greater is the proportion of the metal that will be deposited on the plates, since the solid angle they subtend from any point on the coil is inversely proportional to the square of the distance. A short distance also conduces to a small plating chamber. If the distance is too short, however, there will be a tendency toward uneven plating — the portion of the plate which is directly underneath a

drop of plating metal would tend to get the greater deposit.

Another factor affecting the distance is the heating of the quartz plates themselves. It was found that considerable heating of the plates was desirable, since it drove adsorbed gases from the surface and gave better adherence to the metal. A distance was finally selected that gave good overall results with all factors taken into account. Having settled on a distance, it was now possible to determine the amount of metal that had to be vaporized to secure the desired thickness of deposit. It was found possible to eliminate the time factor from the plating process by placing on the heaters just the amount of metal required to be vaporized to give the desired deposit, and then to continue the process until all the metal was vaporized. This proved to be a satisfactory method of controlling the process, since the time required is intimately associated with the rate of vaporization, which in turn is affected not only by the current through the heaters, but by the pressure in the cylinder. By vaporizing all the metal present, the necessity of correlating all these factors for each run was avoided.

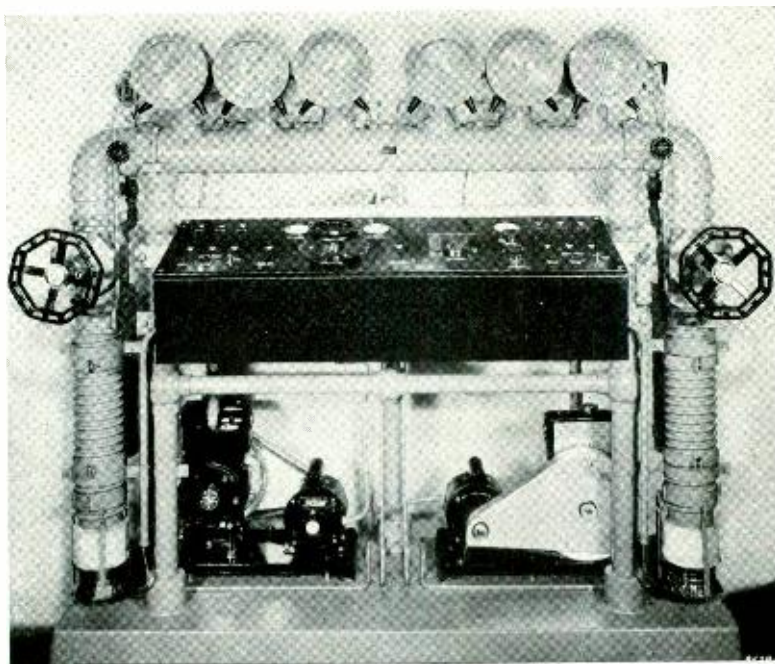

Fig. 3—A group of six plating cylinders and two vacuum pumps form a plating unit operated from a single control panel

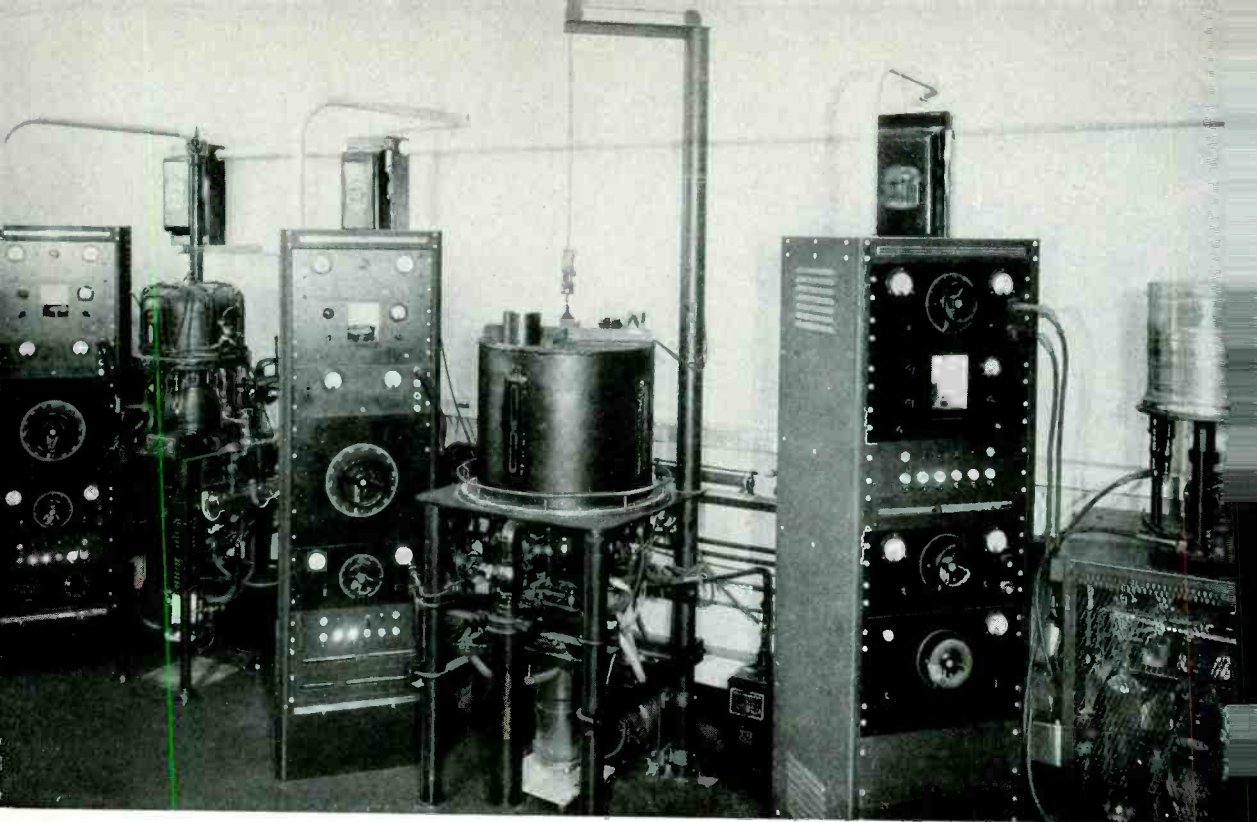

Fig. 4—Experimental vapor plating machines in the Murray Hill Laboratories

A bank of these plating units as employed in the Western Electric Company plants is shown in Figure 3. Six cylinders are operated from a single control panel. These are usually operated as two groups; plating will be in progress in one group of three while the other three are being prepared for the next run. Each group has its own vacuum pump and controls.

Pumping is done in two steps. After the cylinders have been closed and while the pressure within them is relatively high, a pump is connected to the manifold beneath the cylinders at a point above the large valves at the left and right of the control panel. After the pressure has been reduced to about one-hundredth of a millimeter of mercury, this connection is closed, and the large valve is opened to give access to the oil-vapor pump below it. An electric heater at the bottom of this pump vaporizes the oil in the lower chamber, and the oil vapor flows up through a series of concentric chambers and is then deflected downward by a series of baffles that form nozzles. The fast downward stream of oil vapor carries the air from the cylinders downward. The outer wall of the pump is cooled by an external

water coil, and as the oil strikes the cold surface, it condenses and runs down the sides to the oil reservoir below through a narrow annular passage that is always filled with oil, and thus blocks a backward flow of oil vapor. The air, of course, is not condensed, and continues to flow downward and is evacuated near the bottom through another connection to the motor-driven pump. Suitable instruments on the control panel indicate the vacuum under both conditions of pumping. Current is not turned on for plating until the pressure has been dropped to about a hundred-thousandth of a millimeter of mercury.

After the desired vacuum has been obtained, current is turned on to start vaporizing the metal. Values of current are specified that will melt the metal and cause continuous evaporation without danger of splashing or spraying. At the beginning of the process, the current is usually low, and is then increased to some specified maximum. When this stage is reached, the resistance of the heaters is below normal because of the plating metal on them. As the metal continues to evaporate, the resistance of the wires rises, and the current tends to drop.

The voltage applied is then raised to maintain the current constant. A steadily increasing voltage will then be required until all the metal has been evaporated. After this occurs, the resistance of the wires will remain constant and no further increase in voltage will be required to maintain constant current. This condition is taken as an indication that the metal has all evaporated from the heater filament.

When this stage is reached, the current is turned off and the cylinder is then allowed to cool. The pumping connection is then closed, air is admitted to the cylinder, the tray is drawn out, and the crystals are turned over for plating on the other side.

As already mentioned, these machines were developed for use in the Western Electric plant. Much of the experimental work, however, was done with different forms of plating machines. Some of these installed in the Murray Hill Laboratories are shown in Figure 4. With these machines, all factors may be varied as desired, and improvements are continually being sought.

The machines described above have been used in plating large numbers of crystals supplied to the Armed Forces. The procedures have been so well defined that good results are obtained with reasonable precautions. Perhaps the greatest attention must be paid to keeping the crystal surfaces clean before plating. After cleaning, they must be handled only with clean tweezers, since a single touch with a finger will leave grease traces that will spoil the adherence of

the plating. Even almost invisible traces of lint deposited from the air will char and leave black spots. With the precautions described, high quality crystals are readily obtained.

THE AUTHOR: H. G. WEHE received the A.B. degree from Washburn College in 1922 and the



M.A. degree from the University of Kansas in 1925. In the meantime he had taught physics and chemistry, and he spent one summer in test-board work with the Southwestern Bell Telephone Company. In 1926 he joined the E. of M. Department of the Western Electric Company, but in

1929 transferred to Bell Telephone Laboratories where he became a member of the Technical Staff with the Research Department. His first work was in magnetics and on the deposition of carbon films on ceramic materials. Since 1923, however—except for a year during the war developing radar tubes—he has been engaged in studies of the deposition of thin films either of the semi-transparent or non-reflecting types, or to serve as electrodes or resistors. He holds a number of patents in the fields of electro-chemistry, ceramics, and pyro-magnetics, and invented the pyro-magnetic motor, which was displayed at both the San Francisco and New York World's Fairs and at the New York Museum of Science and Industry, The Franklin Institute and the National Academy of Sciences.

Press Demonstration of the AN/TRC-6

RADIO Equipment AN/TRC-6, described by H. S. Black on page 457 of this issue, was demonstrated on October 31 to about 100 reporters and others at 140 West Street, New York. Assembling on the 31st floor of the Telephone Building, the audience was greeted by A. B. Clark, who introduced Major General William S. Rumbough, formerly chief signal officer of the ETO. "For communication between higher echelons," said General Rumbough, "radio was an important adjunct to wire because it could be installed so quickly. Another advantage of radio is in transportation; I don't think any person here quite realizes the tremendous importance of transportation in the field. You may have something invaluable here, want it hundreds of miles away and everyone else is asking for it—everyone needs it so every ton you save is of importance, if you must put it in very quickly. A hundred-mile link radio relay weighs only 25 ship-tons whereas an equivalent of wire weighed 94 ship-tons. When you go to putting in a wire line, say a hundred miles, you assemble four battalions, approximately

2,000 men, and it will take at least 10 days to put in that wire whereas with 30 men you can get your radio relay operation going within two days."

Military use of the equipment in Germany was described by Captain William R. Greer, who had charge of the New Equipment Introductory Detachment of the Signal Corps which installed it.

Following Captain Greer, H. A. Affel described the operation of the system. The audience then went to the roof to inspect the antennas, and also to participate in a demonstration. Of the system's eight channels, one was set up for 18-channel teletype; one for facsimile transmission; and six for two-way telephone between New York and Neshanic. Some of the guests talked with engineers at Neshanic using a single radio link. Then four more radio links were cut in, extending the radio distance from 40 to 200 miles. Seven voice channels were then looped to give 1,400 miles of two-way voice transmission. Finally, by changing from two-way to one-way transmission, a 2,800-mile airline circuit was provided with both talker and

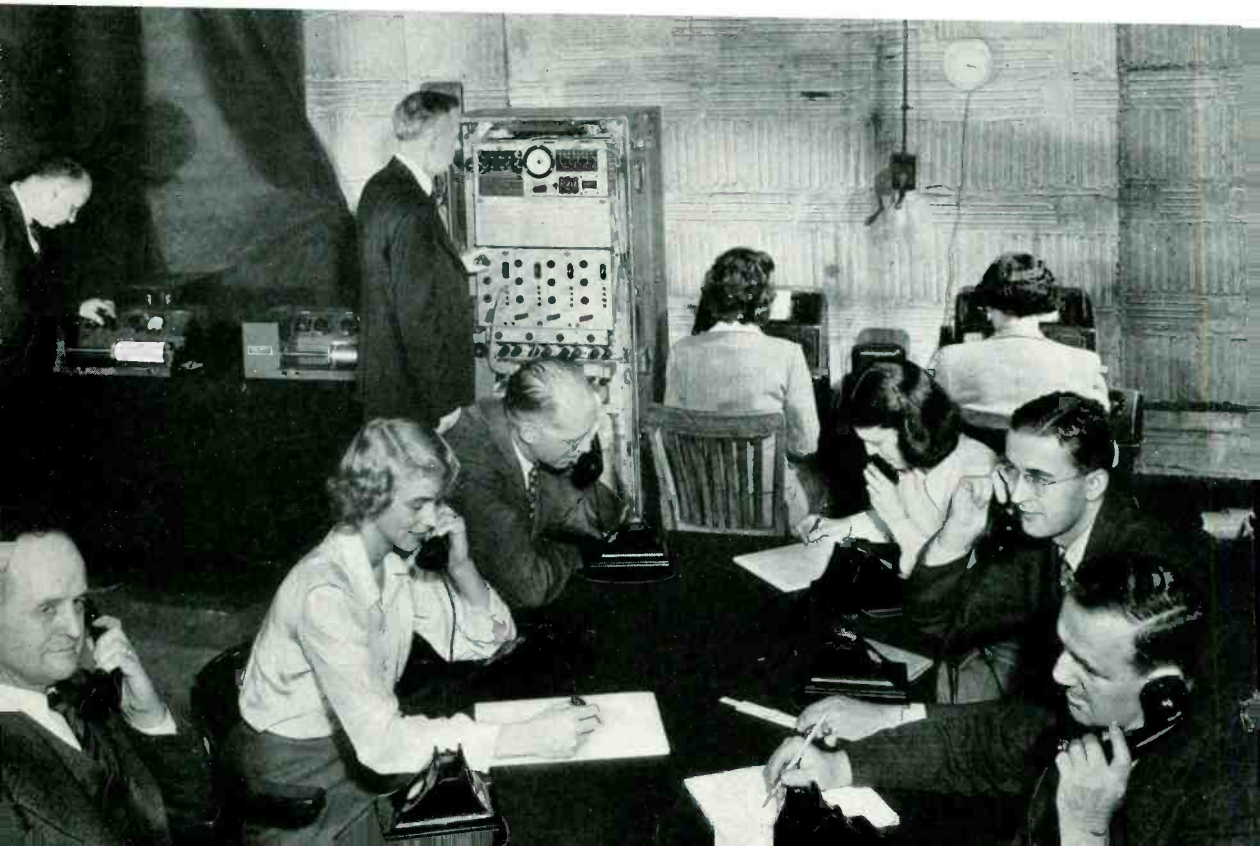

listener in New York. By means of bridged receivers, all members of the audience were able to listen to these conversations. In all cases the quality of transmission was very satisfactory.

Making the demonstration was H. S. Black, with J. W. Beyer as chief of staff. At New York were: G. P. Wennemer, F. A. Muccio, N. Lund, W. E. Evans, H. C. Franke, Miss Ruth Aitken and J. O. Edson. At Neshanic were: C. R. Meissner, J. J. DeBuske, J. G. Gellings, and D. M. Terry. In charge of teletype was W. A. Phelps, with T. M. Torrens and L. E. Melhuish at New York and A. Wilson and G. J. Kandel at Neshanic.

Visitors at Neshanic included local newspapermen and a number of public relations people of New Jersey Bell.

A few days earlier a dress rehearsal of the demonstration was given for a number of Army and Navy officers, including Major General Van Deusen, Brigadier General Sherrill, Brigadier General Lenzner and Captain Berkeley of the Navy. Laboratories guests at the demonstration and at a preceding luncheon tendered by Western

Demonstrating the AN/TRC-6 radio relay system. Six people seated around a table at New York—left to right, J. W. Beyer, Mrs. I. S. Barton, G. P. Wennemer, Miss R. A. Aitken, W. E. Evans, F. A. Muccio—are holding simultaneous two-way telephone conversations with six other people at Neshanic, N. J., over a 200-mile air path involving four AN/TRC-6 microwave relays and two AN/TRC-6 terminals. Simultaneously over this eight-channel system, the other two channels are being used for facsimile and voice-frequency telegraph. L. E. Melhuish, standing on the left, is transmitting the weather map of the day to Neshanic over a two-way facsimile system. W. A. Phelps, standing in the center, is adjusting voice-frequency carrier telegraph equipment which helps to provide the eighteen independent telegraph channels that are being transmitted over one of the eight message channels. Seated in the background and on the right are Mrs. R. A. Bari of the Laboratories and Miss L. A. Peppell of the New York Telephone Company operating teletypewriter machines connected to two of the eighteen teletypewriter facilities.

Electric were O. E. Buckley, R. L. Jones, D. A. Quarles, H. A. Affel, R. K. Honaman, H. S. Black, T. J. Grieser, F. A. Polkinghorn and P. B. Findley.

R. K. Honaman Appointed Director of Publication

Now in charge of the Laboratories' publications, as Director of Publication, is R. K. Honaman. Under his supervision are advertising, technical publications, information



R. KARL HONAMAN

for the popular and technical press, the magazine BELL LABORATORIES RECORD, and other informational services.

Graduating from Franklin and Marshall College in 1916, Mr. Honaman spent two and a half years in Washington during World War I in studies relating to airplane engine design. In 1919 he joined the D & R and with that group transferred to Bell Telephone Laboratories in 1934; his work dealt with protection of telephone circuits. When, at the beginning of the war, the Laboratories undertook to train technicians for the Army and Navy on radar and related developments, he organized the School for War Training and was its Director until May, 1945. Since then, he has been an Assistant Director of Publication.



J. E. Ranges (left) takes over as Commander. Clockwise from this end: O. H. Danielson and his nephew, Donald Danielson, J. F. Jessich, H. J. Delchamps, K. F. Rodgers, A. H. Leigh, W. E. Mougey, A. W. Dring, E. I. Pratt, A. D. Soper, L. P. Collins and T. B. Grant

American Legion Post Installation

The annual installation of the 1946 officers of Western Electric Post 457 of the American Legion was held on October 23, at Hotel Van Rensselaer in New York City. More than one hundred veterans of World Wars I and II were present for the dinner and special program which was under the direction of L. H. ALLEN.

The installing officer, New York County Commander John J. Lawlor, was introduced by Commander J. R. Bardsley. Those installed were: J. E. RANGES, Commander; H. J. DELCHAMPS, First Vice-Commander; F. T. MEYER, Second Vice-Commander; L. B. EAMES, Finance Officer; H. H. HALL, Assistant Adjutant, all from the Laboratories; F. T. Deputy, Third Vice-Commander, from the Western Electric Co. at 120 Broadway; H. Bongard, Adjutant;

L. F. LaValley, Sergeant at Arms, from the Western Electric Co., 395 Hudson St., and A. H. Leigh, Chaplain, Western Electric Co.

Following the installation ceremonies, Commander Ranges introduced O. L. Mabe of the Western Electric Co. at 195 Broadway as the toastmaster for the evening. GEORGE DOBSON, Past National Commander of the 40 and 8, spoke briefly on expected happenings at the national convention. Past Commander FRED GIVEN presented the Past Commander's medal to retiring Commander Bardsley. Guest speakers Cliff Derling, R. D. DEKAY and L. L. GLEZEN gave interesting talks on their experiences in the war. LT. COMDR. V. M. MESERVE made a special trip from Washington to attend. Telegrams and letters received from COL. HAYWARD and COL. ENGELBERG and LT. COL. GREENALL were read.

F. J. Given (left) presents the Past Commander's medal to J. R. Bardsley. At the right are shown the new officers being installed



Visible Speech Demonstrated

ON NOVEMBER 8, the Laboratories of visible speech. This novel system, conceived some years ago by R. K. Potter of these Laboratories, was developed in one form as a secret Army project, but since it seemed to have great potential value for teaching the deaf to talk, it has also been developed in a form more suitable for this latter purpose. Those totally deaf from birth have extreme difficulty in learning to talk because they have never heard the human voice and cannot hear the sounds they make themselves. So great are the obstacles in their path to acquiring speech that only a very few ever overcome them, and at best, the speech they achieve is difficult to understand. Visible speech provides a promising means of overcoming these difficulties, since a deaf person can watch the speech patterns made by his instructor and then watch those he himself makes as he tries to duplicate them. He then modifies the sounds he makes until his visible speech patterns assume the desired forms.

The progress possible by this method was demonstrated by Edgar Bloom—a member of the Laboratories Technical Staff who is congenitally deaf. Mr. Bloom read patterns made by members of the audience and responded to them—the audience seeing his speech patterns and hearing his voice.

As arranged for instruction and as shown at the demonstration, visible speech appears as a traveling pattern of light and shade. Speech itself is a time sequence of variations of two audible characteristics—frequency and intensity—and thus may be represented



Visible speech pattern of "unusual"



R. K. Potter explaining the principles of visible speech at a demonstration in the West Street Auditorium

visually as a similar time sequence of two visual characteristics. In the visible speech patterns, intensity is represented by the brightness of the light, and frequency by height above the baseline of the pattern. Visible speech patterns thus have variations that are the visual counterpart of the audible variations of speech. Some time, of course, is required to learn to read visible speech, but that proficiency can be obtained with reasonable effort was demonstrated by Miss Rosemary Kennedy and Miss Selma Graber. These girls have normal hearing but have learned to read visual speech patterns under the tutelage of Miss Harriet Green, who was also the instructor for Mr. Bloom. Misses Kennedy and Graber carried on a conversation over a telephone that had no receiver. The incoming speech was displayed as visual speech patterns on a screen. They read these patterns and replied orally. A fuller account of the technique and possibilities of visible speech will be described in a forthcoming issue of BELL LABORATORIES RECORD.

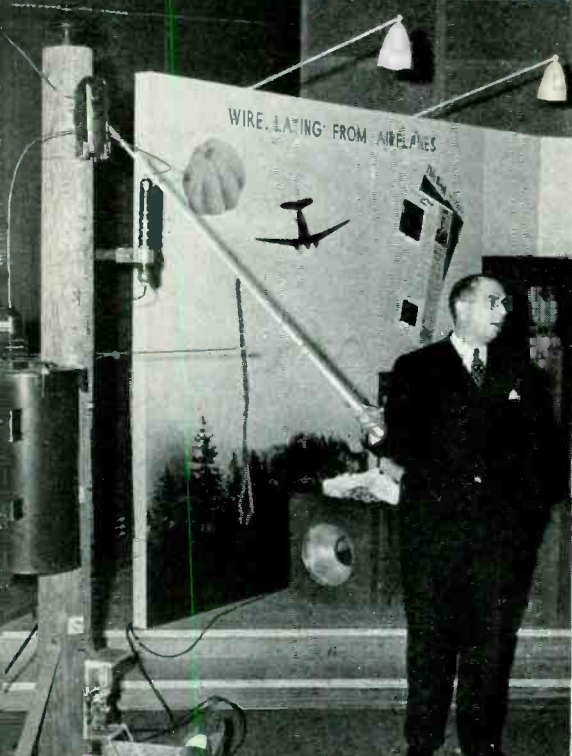
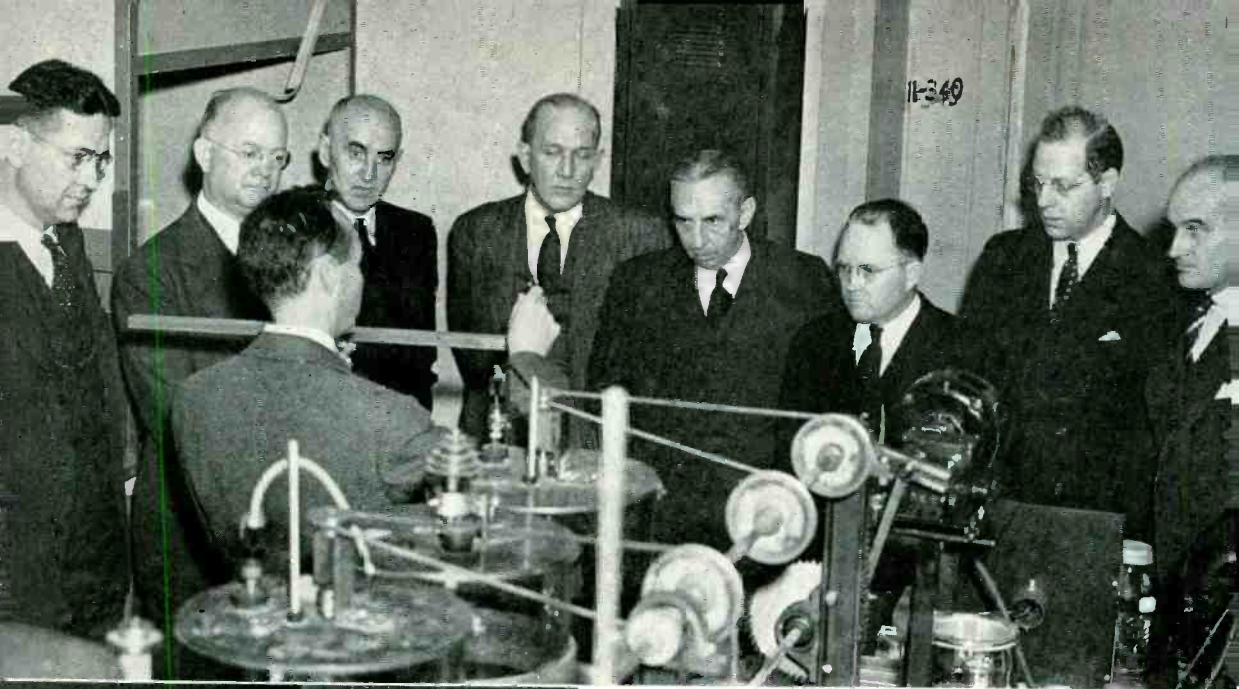

BELL SYSTEM PUBLIC RELATIONS GROUP AT MURRAY HILL
At the left, P. W. Blye describes rural power-line carrier equipment and, below, G. N. Thayer discusses radio-relay systems. Other views were taken during the inspection trip

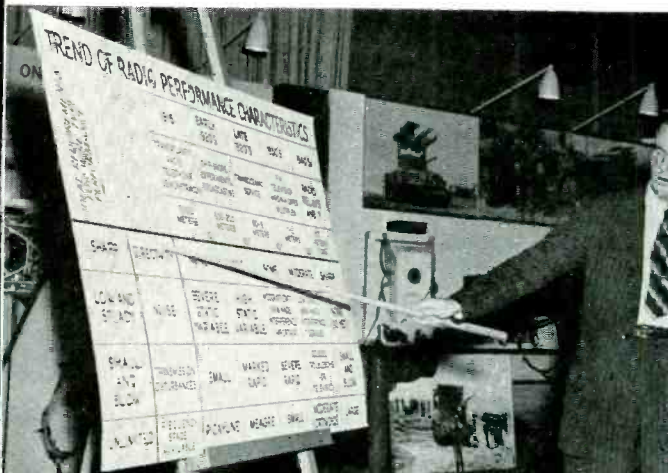

Public Relations Conference

Members of the Bell System Public Relations Conference on October 17 visited the Murray Hill laboratory. They were welcomed by O. E. Buckley and then, with R. L. Jones as Master of Ceremonies, they were given a general picture of the work accomplished by the Laboratories during the war years and an idea of communications developments planned for the post-war period.

D. A. Quarles described the development of radar equipment and G. N. Thayer the radio relay system including the New York-Boston project. P. W. Blye discussed the miniature carrier for Spiral-4, wire laying from planes and rural power-line carrier systems. F. J. Scudder described the automatic message accounting system and H. O. Siegmund discussed and demonstrated rockets.

After lunch in the service dining room, the conference was divided into four groups for visits to individual laboratories. These included the telephone instrument laboratory where the development of instruments and loudspeakers was described by W. H. Martin; rubber research, F. S. Malm; the metallurgical laboratory, D. H. Wenny; and piezo-electric crystals, S. O. Morgan.

Edgar Bloom First Deaf Student of Visible Speech

Edgar Bloom, Jr., a congenitally deaf engineer, came to Bell Telephone Laboratories as a member of the Technical Staff to participate in the training program on visible speech. He also devotes part of his time to corrosion engineering in the Chemical Laboratories. A native of New York City, Mr. Bloom is a product of its schools, Public School for the Deaf P.S. 47, De Witt Clinton High School, Columbia College from which he received his B.A. in 1932 and

"The Telephone Hour"

NBC, Mondays, 9:00 p.m.

December 10	Marian Anderson
December 17	Robert Casadesus
December 24	Helen Traubel
December 31	Fritz Kreisler

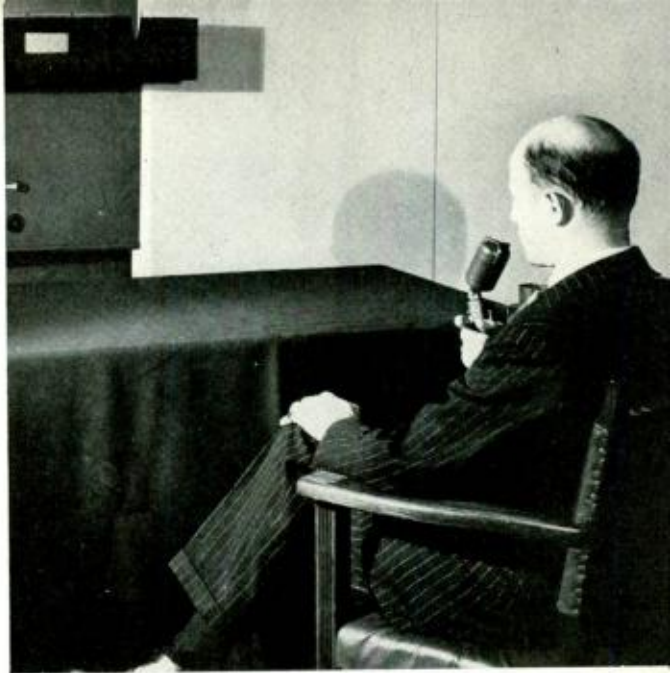

Reading from a translator, Edgar Bloom, though totally deaf, carries on a conversation

the School of Engineering at Columbia where he received the Master of Science degree in chemical engineering in 1934. After graduation he travelled around the world, visiting France, Italy, Egypt, India, China and Japan.

Mr. Bloom has been married for six years and has a daughter three years old. Despite his handicap, he does nearly everything that a person with hearing can do. He is interested in chess, has played in duplicate contract bridge tournaments and drives a car. His other hobbies are mathematics and reading, particularly biographies, because he enjoys knowing the obstacles which others faced and overcame. Other than having a lamp go on in each room when the doorbell is rung, his apartment in Jackson Heights is the same as yours and mine. To awaken him each morning, a buzzer vibrates under his mattress when his alarm clock rings. He is enthusiastic about visible speech because it will do so much for the deaf by improving their speech, by encouraging them to mingle more among people and by enabling them to enjoy such facilities as the telephone, radio broadcasts and sound motion pictures. Prior to coming to these Laboratories, Mr. Bloom had been employed for five years first as a draftsman and then as a chemist in the American Cyanamid Corp. at Bound Brook, N. J.



Members of the Employee-Management Transportation Committee at Whippany were (left to right) I. W. Whiteside, Chairman; Agnes Glaab, A. L. Johnsrud, E. H. Kampermann and R. Van Luijpen

Transportation Award

During the period of gasoline rationing, all organizations employing over 100 people were required by the OPA to maintain Organized Employee-Management Transportation Committees. The function of these committees was to approve employee requests for tires and gasoline used in getting to work. Through regular reports and inspections, OPA representatives checked the performance of all committees. Companies leading in efficiency in operation were issued Merit Citation Awards.

On September 28, R. J. Tarrant, Director of the Newark District OPA, awarded two of these citations to the Laboratories for the high car pool average at Murray Hill and Whippany. The car pool average for the main shifts at these places was 4.4 and 4.1 passengers per car, or second and seventh,

respectively, out of 373 companies. These awards were presented to J. S. Edwards and I. W. Whiteside with high praise for the efficient manner in which Laboratories' committees, headed by Mr. Whiteside as Coördinator of Transportation, had operated throughout the gasoline rationing period.

The awards were presented to representatives of Murray Hill and Whippany by Mr. Edwards at luncheons held at both places.

An Organized Transportation Committee also functioned for New York locations. These locations were not eligible for an award on the basis of car pool averages as practically all of the cars used in the process of getting to work here were driven only relatively short distances to commuting stations where full car pools were generally impracticable. The Committees which functioned at Holmdel and Deal obtained very favorable car pool averages of 4.3 and 3.6 passengers per car, respectively. From a performance point of view, these locations were eligible for awards but as they had less than 100 employees in each place, no separate awards were granted, but a letter of commendation was received for the services rendered by the combined efforts of all of the committees.

Representatives of Employee-Management Transportation Committees functioning at various Laboratories locations under

Members of the committee at Murray Hill were (left to right) A. J. Akehurst, I. W. Whiteside, Chairman; Edwina Wylie and H. O. Schroder

WORK ACCOMPLISHED BY THE EMPLOYEE-MANAGEMENT TRANSPORTATION COMMITTEES

Gasoline applications processed.....	15,000
Tire applications processed.....	1,600
Cars involved.....	2,500
Interviews (personal or by telephone)	50,000
Miles per month being driven at end of rationing.....	430,000
Estimated miles of driving involved.	15,000,000



the guidance of Mr. Whiteside as Coördinator of Transportation and Chairman of each Committee are as follows: New York—William Bodenstedt, H. K. Leicht and Catherine Cheevers; Murray Hill—A. J. Akehurst, H. O. Schroder and Edwina Wylie; Whippany—E. H. Kampermann, R. Van Luipen, A. L. Johnsrud and Agnes Glaab; Deal—R. L. Conklin; and Holmdel—W. B. Angerole.

General Harrison Speaks at West Street

Major General William H. Harrison, again a Director of the Laboratories, was the guest speaker at an executive conference in the Auditorium on November 1. His five years in the Army were the high point of his career, said General Harrison; his procurement job in the Signal Corps had been greatly aided by the coöperation of the Laboratories and Western Electric. The stability of our apparatus and its freedom from trouble was always a source of deep satisfaction to him.

His duties had taken him all over the globe, he said, and nowhere had he seen opportunities like those that are open to us in America, and particularly in the Bell System.

Introducing General Harrison, Dr. Kelly spoke briefly of some of the current problems in converting the Laboratories to its peacetime program.

Telephone Pioneers of America Elect Randolph Eide President

Randolph Eide, President of The Ohio Bell Telephone Company, has been elected President of the Telephone Pioneers of America for 1946. Mr. Eide will succeed C. G. Stoll, President of the Western Electric Company, who will remain on the Executive Committee.

In recent years, the Pioneers have expanded into a service as well as a social organization, giving attention to ill and retired members, encouraging development of hobbies for diversion, and gathering telephone historical data. During the war, 3,000 retired or "life" members returned to active telephone work to help out, while others engaged in wartime volunteer activities. Over 900 Pioneers served in the Armed Forces,

where most of them, as experts of proved ability, were officers in communications divisions. The organization launched one of its most appreciated and gracious projects—the visiting of hospitalized veterans who were telephone employees or relatives of telephone people. Activities have been brought closer to the members by the formation of local councils and clubs, of which there are now about two hundred seventy-five.



F. B. Llewellyn Elected President of Institute of Radio Engineers

The Board of Directors of the I.R.E. announced on November 13 that F. B. Llewellyn of Bell Telephone Laboratories had been elected President for the year 1946. Dr. Llewellyn is an authority on the design of vacuum tubes used for communication and electronic control purposes. His theoretical study of the subject resulted in his invention of the ultra-high-frequency oscillator tube which is fundamental to the development carried on during the war in radar and other communications devices. He is also known for his work on stabilized oscillating circuits that are used extensively in radio and telephony.

Dr. Llewellyn was graduated from Stevens Institute of Technology in 1922 and received his Ph.D. degree from Columbia in 1928. In 1936 he received the Morris Lieberman Memorial prize of the Institute of Radio Engineers for his analysis of reactions within the vacuum tube.

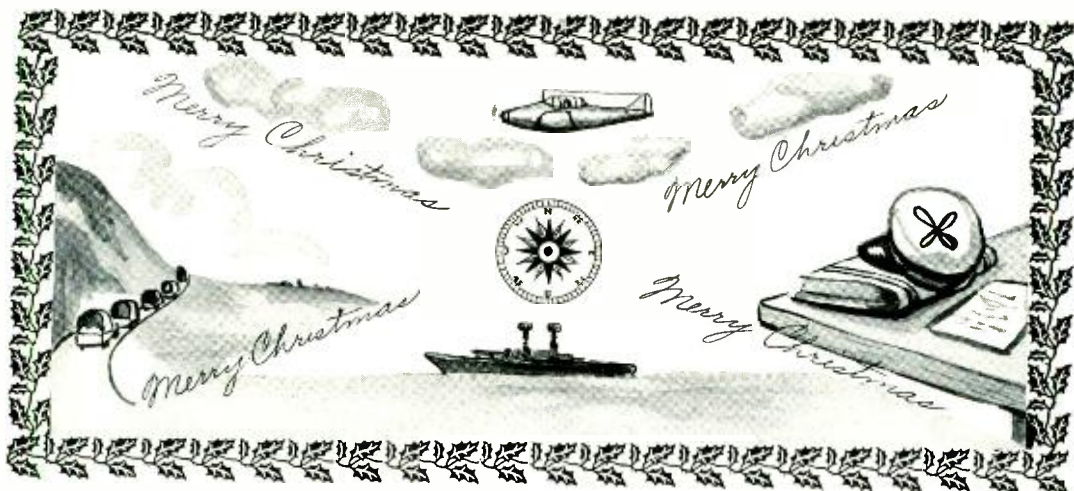

Lt. Ernest F. Neubert

Ernest F. Neubert enlisted in the Army Air Forces on July 1, 1942. He completed a gunnery school course, was rated a sergeant, and flew to England in a B-26. During the winter of 1943 and spring of 1944 he went on thirty-six missions over France, Holland and Germany as a tail gunner, for which he was awarded the Distinguished Flying Cross and Air Medal with three clusters. Deciding to take aviation cadet training, Sergeant Neubert, still under twenty-one, wrote home for his parents' consent and was one of the first twenty-six men to return. In July of this year he graduated from Selman Field, Monroe, Louisiana, as a navigator and is now back at work with the Laboratories until the opening of the spring term at the Polytechnic Institute of Brooklyn.

Major Howard J. Keefer

Major Keefer was a first lieutenant when, called as a reserve officer, he reported to the 5th Coast Artillery at Fort Hamilton, New York, in April, 1941. He transferred to the Hawaiian Department as Communications Officer for the Anti-Aircraft Artillery Brigade and was at Pearl Harbor during the Japanese attack. On that day, his brigade expanded into a command called the Hawaiian Anti-Aircraft Artillery Command of which he was Signal Officer until April, 1945. After forty-four months overseas, Major Keefer was reassigned to the Signal Corps Officers' Replacement Pool at Fort Monmouth for six weeks and thereafter to Camp Crowder, Missouri. He became Control Officer of the Inspection and Control Di-

vision of the Army Service Forces Training Center and served in this capacity for three months before his discharge.

Capt. Samuel C. Tallman

Upon the mobilization of the National Guard, Capt. Samuel C. Tallman reported to Fort Jackson, S. C., with the 102nd Cavalry on January 6, 1941. From there he went overseas in August, 1942, to England and landed on Omaha Beach on D-Day. As communications officer he trained radio operators in setting up radio communications and in cryptography. Under combat conditions anywhere from 300 yards to two miles from the front, he saw that radio and telephone communications systems were kept working. He has now returned to his former job in sound power equipment at Murray Hill.

Lieut. Arthur F. Schweizer

Lieut. Arthur F. Schweizer has returned to work. He enlisted in the AAF in February,



MAJ. H. J. KEEFER

LT. E. F. NEUBERT

1944, and trained at Santa Ana, Calif.; Phoenix, Ariz.; Bakers Field, Calif.; Douglas, Ariz.; Lincoln, Neb., and N. Y. C. to fly B-25's. He received his commission at Douglas, Ariz., in March and was released with surplus personnel after the cessation of hostilities.

Raymond S. Yerden

Cpl. Raymond S. Yerden, U.S.M.C.R., has exchanged his uniform for civilian clothes and is now on leave to attend college. He went overseas on December 6, 1943, and was engaged in refrigeration maintenance for twenty-one months in New Caledonia, Samoa, Pearl Harbor, and Guam. He was sent back for a V-12 and O.C.S. assignment; however, the September class was abandoned and he was permitted his choice between additional duty and discharge from service.

Lieut. Edward J. Zillian

Enlisting in February, 1943, Lieut. Edward J. Zillian studied meteorology at the University of Iowa for six months before the course was closed. He then took aviation cadet training and was commissioned a navigator. During his B-17 combat training at Rapid City, S. D., the war ended and he was re-assigned to B-29's at Ellington Field, Texas. After V-J Day, he was released with surplus personnel from Randolph Field, Texas, and has returned to work with the Laboratories in the Development Shops.

Henry Widmann

Henry Widmann has returned to work for the Laboratories after submarine duty with the Navy. He was responsible for the main-

tenance of radio and SJ radar, having received radio training at Bliss Electrical School, the Radio Matériel School at Treasure Island, Calif., and radar training at the New London Submarine School. For six months he served aboard a submarine tender in Majuro in the Marshall Islands and then transferred to a submarine for another six-month period prior to returning to New London in January.

Francis M. Hodge

S/Sgt. Francis M. Hodge entered military service on April 30, 1941, and engaged in property auditing work at Fort Monmouth, keeping track of the supply accounts for his regiment. In August, 1944, he was transferred to Fort Dix to instruct Negro troops in heavy construction work and spent one year in that location as classification specialist. He returned to Fort Monmouth as a cryptographic technician and was ready to go overseas just prior to his release on October 5. Sergeant Hodge has returned to work in the General Accounting Department at Eighteenth Street.



LT. E. J. ZILLIAN

F. M. HODGE



R. S. YERDEN

LT. A. F. SCHWEIZER



HENRY WIDMANN

CAPT. S. C. TALLMAN



J. R. MAY



CAPT. L. G. RAINHARDT



D. H. FREESE



LT. F. R. HULLEY

Lieut. Thomas B. Horton

Lieut. Thomas B. Horton enlisted in the AAF in January, 1943, and became a B-24 pilot. He went to England with the 8th AAF in December, 1944, and flew 21 combat missions for which he was awarded the Air Medal and two oak leaf clusters. Following V-E Day, he returned to Pratt, Kansas, where he was assigned to B-29's. He has been welcomed back to the Patent Drafting Department.

Thomas J. Gilchrest

Thomas J. Gilchrest entered service on March 14, 1941, and was attached to the Cavalry Replacement Center, Fort Riley, Kansas, until October 20, 1941, when he returned to the Laboratories. Called again to active duty, effective January 29, 1942, he was given medical training at Camp Ellis, Ill., and later transferred to the Military Police guarding the prisoners of war at that location. He served two years with the 717th M.P. Battalion and, since December, 1944, has been at Fort Ontario, N. Y., Trenton, N. J., and Burlington, N. J., for replacement training. He was reinstated in the Laboratories following his recent discharge.

Charles E. Merkel

Wearing a gold discharge button, Charles E. Merkel resumes his work in the Laboratories after serving his country since May, 1941. He was with the first convoy to land at Cherbourg and with the armored division of the 10th Army fought through the battle of Metz and the Bulge, took Ayl, Germany, advanced on Trier, and crossed the Rhine at Mannheim. Not stopping there, they crossed the Danube and continued through

the Tyrol section to Garmisch when V-E Day was proclaimed, at which time their front line was on its way to Innsbruck. Sergeant Merkel, who had charge of all documents for G-2, received the Bronze Star Medal for meritorious service from November 1, 1944, to May 6, 1945.

Capt. Leroy G. Rainhardt

Capt. Leroy G. Rainhardt returns to work after active military duty which began on June 20, 1942, when, as a reserve officer, he was ordered to Camp Edwards, Mass., for six weeks' training with the Amphibious Command. He made a trip to Northern Ireland and Scotland and returned to Fort Belvoir, Va., to instruct in the engineering school and was later assigned to an Engineering Combat Battalion at Camp Carson, Colorado.

In April, 1944, he assumed command of the 981st Engineering Maintenance Company and went overseas attached to the 12th Corps of the Third Army. He organized and operated production crews for the fabrication of equipment needed for tactical situations such as snow plows, sand spreaders, and special equipment for reducing pill boxes. He received the Bronze Star Medal for making 150 pairs of aluminum skis for attachment to litters for the evacuation of wounded men under fire in deep snow.

David H. Freese

David H. Freese entered the Merchant Marine on March 6, 1944, and was rated a Chief Machinist's Mate following a six-week course in marine engineering at Hoffman Island. He made six trips to Scotland, Ireland, England, and France as operating

engineer on tankers carrying hi-octane gas and two trips to Russia aboard Liberty Ships. On the trips to Russia they sustained repeated air and submarine attacks, losing 24 ships in their 70-ship convoy and seven men in his ship. Upon returning to the States, he was confined for a short while to a marine hospital from shock and subsequently studied marine engineering at Fort Trumbull, Conn., prior to obtaining his release from the service after V-J Day. Mr. Freese now works at Chambers Street on contract terminations.

Lt. Frank R. Hulley

It was easy for Lieut. Hulley to navigate his way back to work with the Laboratories after navigating a B-24 on twenty-seven missions over Germany from his base in Italy. He enlisted in 1943 and following his training was assigned overseas on October 1, 1944. He received the Air Medal with two oak leaf clusters, the Presidential Citation, and five battle stars. While awaiting his return home, he visited Rome, Milan, Florence, Lake Como, the Isle of Capri, and other famous Italian places. Upon his arrival by plane in the States on July 7, 1945, he was assigned to a navigators' pool in Houston, Texas.

Harry Verges

Harry Verges is in the restaurant at West Street after cooking for the 7th Army in Europe. He attended the Bakers' and Cooks' School at Camp Ellis, Ill., and was given the

rating of T/4. In September, 1944, he landed at Glasgow, Scotland, and crossing the Channel from England he landed at Omaha Beach. At Brest there was one house left standing. There he salvaged food from caves and collected food for the French people. Christmas night brought a bombing and shortly afterward they moved on to Saarburg and the border of France and Germany, through Munich, and stopped at Rosenheim. He visited Hitler's hideout in the Alps before shipping for home and had eight weeks more training at Camp Gruber, Oklahoma, in preparation for the South Pacific, but was discharged after V-J Day on the basis of age.

Joseph R. May

Joseph R. May has returned to work as a foreman in the Plant Department at Murray Hill following his discharge from the Army. Soon after Sgt. May entered the Services the Army discovered that he was a good cook and kept him on that assignment for the major part of his one and three-quarters years in the Army. He reports that he is perfectly willing to have his wife do the cooking in the future; in fact, goes so far as to say that he expects her to do so.



LT. T. B. HORTON

Lawrence M. Cassano

Lawrence M. Cassano is glad to be back to work, but will not forget some of his experiences while serving with the Seabees. He took boot and advanced training at Camp Peary, Va.,



HARRY VERGES



C. E. MERKEL



L. M. CASSANO



HAROLD PHARES

was attached to the 5th Amphibious Marine Corps, 147th Construction Battalion, and at Camp Parks, Calif., was assigned to the 7th Battalion. On December 19, 1944, he shipped overseas, spent two months in Hawaii, two months in Saipan, and took part in the Okinawa invasion. He suffered two and a half months of bombings while constructing a seaplane base and fuel and cargo piers. One morning he saw seven Japanese planes shot down and the S.S. *Livermore* hit on the bridge structure which resulted in ten casualties. He was discharged from Lido Beach, L. I., "on October 9, 1945, at 5 p.m."

Harold Phares

Another returned veteran is Harold Phares who attended radio school at Scott Field, Illinois, after entering the Army in February, 1943, and gunnery school at Fort Myers, Fla. He flew transition in a B-25 as a radio operator and went to Corsica, Italy, in September, 1944. As an aerial photographer photographing bomb strikes over Austria, Yugoslavia, the Brenner Pass, and Po Valley, he piled up seventy missions and received the Air Medal with six oak leaf clusters. He returned to the States this summer and was assigned to Lincoln, Nebraska, as a draftsman at the sub-depot on maintenance of aircraft.

Capt. Roderick K. McAlpine

Capt. Roderick K. McAlpine has returned to his job after active military service beginning on February 16, 1942. He was at Fort Monmouth a short time before sailing to Australia. He spent twenty-seven months in the southwest Pacific, including twelve



LT. R. P. CHAPMAN CAPT. R. K. MCALPINE

months in New Guinea at General MacArthur's forward headquarters. He participated in the New Guinea and Papua campaigns. His unit received the Distinguished Unit Citation for the latter. He installed Western Electric switchboards and common battery telephones in New Guinea and part of the time was in charge of most Army communications to other parts of the world, their installation, maintenance, and handling. Air raids were a common occurrence; he estimates that he has survived thirty of them. Most of his time was spent at Port Moresby. Back in the United States, he



LT. W. WIEGMANN CAPT. W. A. VON GLAHN

worked on a special laboratory project of a confidential nature for fourteen months with the Office of the Chief Signal Officer.

Lt. Raymond P. Chapman

Lieut. Raymond P. Chapman received his commission on the field in the Appennines. He began his Army experience by training at Camp Croft, S. C., and Fort Dix, N. J., before going overseas in April, 1942. He spent seven months in Ireland while in the British Isles, and fought through the African campaign at Tunisia, Hill 609, and the Fondouck Pass. With the 5th Army, he landed at Salerno two weeks after the beachhead had been established and chased the Germans up to the Swiss border. In Anzio, Lieut. Chapman was hit by an airburst for which he received the Purple Heart. He also wears the Combat Infantryman Badge and five battle stars. Lieut. Chapman was on the sea, heading for temporary duty in the States, when V-E Day was proclaimed. He has now returned to work in the General Accounting Department of the Laboratories.



David H. Wright's first day back at work after two and one-half years in the service

Lt. Comdr. Thomas H. Neely

Lt. Comdr. Thomas H. Neely has returned to work after distinguished naval service since he was called as a reserve officer to active duty in February, 1942. He was assigned for four months to the Port Director's Office, Miami, Fla., as communications officer and thereafter to the 7th Naval District and Gulf Sea Frontier as radio security officer to set up a chain of high-frequency direction finders from Jacksonville to Key West which caused the German submarines to withdraw in January, 1943. Assigned to the battleship U.S.S. *South Dakota*, he operated against the Germans with part of the British home fleet at Scapa Flow, York Island, off the coast of Norway and south of Spitzbergen. In October, 1943, he was transferred to the U.S.S. *Steamer Bay* which ferried planes and replenishments to the New Hebrides and Majuro, and after transfer to the Third Fleet acted as a replenishment carrier from Manus to operation points off the Palaus and Philippines. In December, 1944, he was transferred to the carrier U.S.S. *Independence* and was at the Iwo Jima, Okinawa, Kyushu, Honshu and Tokyo Bay operations and provided air coverage for the U.S.S. *Missouri* on which the surrender was signed.

Capt. William A. Von Glahn

Capt. William A. Von Glahn enlisted in January, 1943, and was commissioned an aviation engineering officer after five months of special study at Yale University. He also attended the 21st School of Technical Training, an RAF school located in Manchester, England. As Assistant Wing Engineering Officer with the 53rd Troop Carrier Wing, he was responsible for maintenance and repair of all aircraft. Last June he was made a technical inspector to inspect personnel and work on aircraft, vehicles, and all mechanical equipment. He has returned from England and France to work in the Laboratories.

Lt. William Wiegmann

Back on his old job in the Development Shop is William Wiegmann who enlisted in the Army Air Forces and was called to active duty on September 30, 1942. As a B-24 navigator, he flew overseas to Italy where with the 15th AAF he made thirty-three bombing sorties over Germany, Austria, Hungary, Italy, and Yugoslavia. For this he was awarded the Air Medal with two oak leaf clusters.

David H. Wright

David H. Wright has returned to work in the Drafting Department at Whippany following his discharge from the Army Signal Corps. He was a Technician 3rd grade and had spent approximately fifteen months overseas, principally with the Third Army. His specialty while in the Signal Corps was repairing and installing teletype equipment.



Lt. Comdr. T. H. Neely discussing his reinstatement with his former supervisor, H. S. Shope, before his return to work

Some of these installations were made in close proximity to the front lines during the heaviest fighting in the Battle of the Bulge. He has received four battle stars and has the Meritorious Unit Citation.

Bronze Star Medal Posthumously Awarded to Private Harry A. Malone

By direction of the President, the Bronze Star Medal has been posthumously awarded to Private First Class Harry A. Malone of the 83rd Division. The citation is as follows:

“For distinguishing himself by meritorious service in connection with military operations against an enemy of the United States from 15 July 1944 to 2 March 1945, in France, Luxembourg, Belgium and Germany. Private Malone participated with his organization in all its campaigns against the enemy as rifleman and acting squad leader, displayed outstanding courage and leadership at all times. During the Ardennes operation he voluntarily went through the enemy lines to locate a platoon that had become separated from the company. Private Malone was mortally wounded by enemy small arms fire at Neuss while covering the withdrawal of his platoon. . . .”

George E. Linehan

Technical Sergeant George E. Linehan was presented with the Bronze Star Medal.

He displayed outstanding engineering skill while working in a vitally important and highly classified Signal Corps activity. He demonstrated exceptional ingenuity in completing an installation with improvised equipment in a space which prohibited normal arrangement of equipment under extremely restrictive security regulations. By his remarkable inventiveness, untiring efforts, and proficiency in handling the most delicate and intricate machinery, Sergeant Linehan was of invaluable aid to an important Signal Corps project in the Southwest Pacific Area.

Clinton A. Jaycox

Sergeant Clinton A. Jaycox, who is an instrument maker at Murray Hill on military leave of absence, has been awarded the Bronze Star Medal for meritorious service in connection with military operations in Germany. In supervising communications in his infantry company, he frequently had to expose himself to enemy fire to repair vital telephone lines.



C. A. JAYCOX



Major Allen L. Whitman (left) receives the Bronze Star Medal from Col. R. B. Oxrieder. Major General Spencer B. Akin presenting the Bronze Star Medal to Sergeant George E. Linehan (center). Major John K. Mills (right) awarded the Bronze Star Medal for meritorious achievement by General Walter Krueger, CG, Sixth Army, at Luzon, P. I.

Major Allen L. Whitman

Major Allen L. Whitman has been awarded the Bronze Star Medal "for meritorious achievement in direct support of combat operations against the enemy at Manila, Philippines, from 6 February 1945 to 31 May 1945. As representative of the Signal Corps in the advance part of Philippine Base Section, Major Whitman selected and procured various Signal Corps installations, depot and billeting areas. He performed this difficult assignment in the initial phases of operations against the enemy despite the combat still in progress in the city, thus enabling the Signal Corps to support operations against the enemy and prepare for the arrival of higher headquarters at a very early date.

"Major Whitman was later assigned as Communications Officer and was responsible for coordination of administrative communications facilities on Luzon, where his responsible judgment and initiative were largely responsible for the successful meeting of all long-distance telephone and teletype communications requirements." Major Whitman is now in Batangas, Philippine Islands.

* * * * *

PAUL V. DIMOCK has been reinstated from a personal leave of absence, effective March 9, 1942, which was granted in order that he

Leaves of Absence

As of October 31, there had been 1,013 leaves of absence granted to members of the Laboratories. Of these, 129 have been completed. The 884 active leaves were divided as follows:

Army 483 Navy 298 Marines 29

Women's Services 74

There were also 19 members on merchant marine leaves and 6 members on personal leaves for war work.

Recent Leaves

United States Army

Jack J. Confusione Leonard Miaskoff
Francis G. Schlosser

United States Marines

Albert H. Speck



356 veterans of World War II have been employed by the Laboratories

could work for the N.D.R.C. in the Underwater Sound and Airborne Instrument Labs.

LIEUT. JOHN A. LASCO is a staff officer in the Fire Control Design Division of Frankford Arsenal. LIEUT. EDWIN F. BIRGER is at Yuma, Arizona, learning to be a radar operator. FRANCIS X. SULLIVAN is assigned to the Luzon P.O.W. Camp No. 1 as a guard. FRANK B. CATALANELLO has finished basic training and has gone on to an Aero Engine Mechanics' School for further training.

RICHARD E. STREBEL has been serving aboard the destroyer tender U.S.S. *Blackhawk* AD9. EDWARD J. DUGAN is stationed at the Navy Air Base on Majuro in the Marshall Islands. LAWRENCE B. JONES reports he is still working on the turret system in B-29's and has run across numerous pieces of Laboratories developed equipment.

JOHN T. O'SHEA went into Tokyo Bay on September 2 and has now left Yokohama on his way to see more of the Orient.

JOSEPH D. MEAD has been in Italy for seven months operating a PBS station in the Leghorn section.

The following members of the Laboratories on military leaves of absence have received promotions:

T/Sgt. L. R. Bell; 2nd Lt. F. E. Birger; 1st Lt. G. S. Bishop; F. J. Dempsey, HA 2/c; Cpl. A. H. Diegler; Cpl. F. E. Francois; R. F. Graham, ART 2/c; W. H. Gray, RT 1/c; W. W. Grote, RT 3/c; R. A. Hauslen, A/S; S/Sgt. J. Huntley, Jr.; T/Sgt. G. E. Linehan; D. A. Loughlin, S 1/c; A. C. Luebke, F 1/c; D. Maccia, EM 3/c; Lt. Comdr. V. M. Meserve; Major J. K. Mills; F. R. Misiewicz, RT 2/c; R. E. Poirier, A/S; S. Catherine Ridner, S 2/c; H. J. Rohr, EM 2/c; J. Sciortino, S 1/c; T/Sgt. R. W. Search; and T/5 J. A. Zweig.

New Books by Laboratories' Authors

Fundamental Theory of Servo-Mechanisms is the title of a new book by L. A. MACCOLL. It develops the basic mathematical theory used in designing linear servo-mechanisms and also includes a study of a frequently used non-linear type. The book shows the essential identity of linear servo-mechanisms theory and that of feedback amplifiers. It includes new information on oscillating control servo-mechanisms and on sampling servo-mechanisms.

H. W. BODE is the author of a new book entitled *Network Analysis and Feedback Amplifier Design* in which he develops two and four-terminal networks for circuits that include substantial resistance as well as reactance. The general equations include vacuum tubes as well as passive circuit elements and special emphasis is given to network design problems for vacuum-tube amplifiers including feedback.

New Western Electric Plant to Be Erected

As a part of the Bell System's two-billion-dollar post-war construction program, Western Electric Company has purchased property and will construct a new electronic components plant at Allentown, Pa. This

new plant, when operating at capacity, will provide employment for about 1,500 people. The property consists of a 40-acre tract just north of Route 22 at the east end of Allentown. The new location provides ready access to an adequate labor supply, transportation and housing. The site was purchased from the Blue Ridge Real Estate Co.

In the new plant the Western Electric plans to manufacture vacuum tubes, quartz crystals, temperature-sensitive devices and other precision products for use in Bell System communications facilities and in other commercial applications. Plans call for an office building having 50,000 square feet of floor space and a manufacturing building of 250,000 square feet, with related facilities such as a restaurant, medical offices and recreation rooms.

Telephone Service for the Fleet

As part of the New York Telephone Company's extensive preparation for the arrival of the Pacific Fleet in New York Harbor for Navy Day, the company installed banks of telephone booths in offices on thirteen piers where the majority of telephones were wired for expediting long-distance calls by direct connection with long-distance centers in the city. The U.S.S. *New York* is shown below as she lay at the dock opposite the 463 West



Street building. A. J. Daly, in a letter to the Navy Department, suggested that names be painted on the sides of all ships for Navy Day. The Navy liked the suggestion and advised Mr. Daly that the names would be readable from both sides of the Hudson.

Overseas Radio-Telephone Service

Radio-telephone service between France and the United States, interrupted since the German occupation in May, 1940, was restored for public use on November 7. While evacuating the Paris area, the German armies wrecked the French transmitting station at Pontoise, so that new short-wave radio equipment had to be shipped from the Western Electric Company and installed before the transatlantic service could be resumed.

* * * * *

Telephone users in the United States were able to talk with New Zealand for the first time on October 25. With this addition to the overseas service, all countries having at least 75,000 telephones have been brought within voice range of this country. With about 245,000 telephones for its 1,650,000 inhabitants, New Zealand has the third highest telephone development in proportion to its population in the world.

News Notes

O. E. BUCKLEY has been appointed a member of the Board for Prosthetic and Sensory Devices of the National Research Council. The Committee was established at the request of the Surgeon General of the Army to promote research and development in the field of appurtenances for aid of the war-injured.

R. L. JONES was elected a member of the Visiting Committee of Department of Electrical Engineering, Massachusetts Institute of Technology, for 1945-46. Mr. Jones attended the Bell System Public Relations Conference, October 16 and 17, held at Princeton Inn, Princeton, New Jersey.

R. W. KING addressed a group of about forty Chinese communications engineers in Washington on October 7 on the subject *Some Fundamental Attitudes in Industrial Research as Exemplified in Bell Telephone Laboratories*. The Foreign Economic Administration had asked President W. S. Gifford of A. T. & T. Co. to arrange for five



L. D. Plotner celebrates at his retirement dinner

lectures on the Bell System and in addition to Mr. King's talk, four others have been given, one covering the Western Electric Company and three others relating to telephone service.

A. R. KEMP and F. S. MALM met with the Wire and Cable Committee of the WPB in Washington, D. C., on October 4 to discuss plans for the reconversion to natural rubber as this material becomes available.

WILLIAM SHOCKLEY spoke on *Electronic Nature of Metals* before the Basic Science group of the A.I.E.E. on November 27 at the Western Union Auditorium in New York. Earlier in the month Mr. Shockley delivered a talk, *Nuclear Fission and Related Problems*, at the Deal-Holmdel Colloquium held on November 2 at Deal.

D. A. QUARLES took advantage of the Board of Directors' meeting of the A.I.E.E. in Cleveland on October 16 to visit executives and engineers of The Ohio Bell Telephone Co. and tell them of some current developments of interest at Bell Laboratories.



"We almost decided not to have a Christmas tree this year"



Who Are the Cover Girls?

Cover girls on this issue of the RECORD are, left to right, CAROLE OTTMER, RUTH BROWN, ELIZABETH SHEPARD and CATHERINE SWEENEY with GLORIA GREAYER hanging the Christmas wreath. Miss Ottmer is an assistant supervisor in the Stock Control group at Fourteenth Street; Miss Brown, the file clerk of Benefit Department in Room 565; Miss Shepard, supervisor of a group of messengers on the seventh floor; Miss Sweeney, a preliminary interviewer in Women's Employment; and Miss Greaver, a clerk in the outgoing mail group. The maps were borrowed from G. B. THOMAS.

* * * * *

WINTERTIME with shorter working hours spells New England week-ends with sleigh rides and jingle bells the order of the day for EVELYN DOUCET of the Apparatus Development Department. Her family have a Rhode Island farmhouse and a horse they board out during the week, and they hope to have many holidays together there this winter. Evelyn's other interests are the Metropolitan Museum of Art and the ballet—she takes ballet lessons as a hobby.

As a member of the Files in 4-A at West Street she has done many different kinds of

work and has performed all of it willingly and cheerfully despite the stress of war work and long hours of overtime. Prior to coming to the files she had been a mail girl for a short time after having been graduated from Emerson High School in Union City, her home town.

* * * * *

JULY is GRACE TORGESEN's lucky month. This past July she became the bride of Lieut. Robert Torgesen when he returned from overseas and back in July of 1942 she became the secretary of H. J. DELCHAMPS, Apparatus Staff Engineer. An idea of the scope of Mrs. Torgesen's work as a secretary may be visualized when you consider that over 450 people are reporting to Mr. Delchamps from various specifications and standards engineering, drafting, budget case cost, files, secretarial and general service groups.

Mrs. Torgesen joined the Laboratories General Service Department after graduation from Weehawken High School and was later promoted to the secretarial service of Apparatus Staff. With her husband at Lido Beach, L. I., she spends the week-ends there when he is on duty, or in Weehawken when he is free. They are looking forward to February when he hopes to be released from

the Navy. Then they'll visit Lieut. Torgesen's home in Soda Springs, Idaho, his alma mater, the University of Idaho, the national parks and other beauty spots of the West, and possibly the Pacific Coast before they finally decide where they are going to live.



H. J. Delchamps' dictation is a large part of Mrs. Torgesen's work

As part of her work, Evelyn Doucet returns a specification folder to its place in the file

A SUMMER JOB at Bell Laboratories during her Junior year at Good Counsel College decided LAURINA O'BRIEN upon returning as a technical assistant when she received her degree in chemistry in 1944. In her work in the microchemical laboratory she specializes in the testing of minute foreign particles which accumulate on telephone contacts and on other apparatus. For instance, in the accompanying picture Miss O'Brien was making a microscopic test on a small amount of



Laurina O'Brien makes a microscopic test

corrosion from a relay lead wire to determine the nature of the corrosive agent, the wire having been sent in from a piece of telephone equipment. Upon completion of her tests, the report of her findings was sent eventually to the central office from which the corrosive wire originated. Tests are made with miniature equipment and frequently the specks under consideration weigh twenty-four millionths of an ounce.

The only one of three daughters to follow their father's engineering bent, Miss O'Brien was vice-president of the Science Club at college and still prefers technical reading to all other, even for relaxation.

Josephine Kaiser of Switching Apparatus checks a parts list with F. E. Masek



JOSEPHINE KAISER is another member of the Laboratories whose technical training was received in the Part-Time Technical Training Course for Women Technical Assistants given by the General Employment Department. Miss Kaiser came to the Laboratories after graduating from Hunter College High School and is now attending evening college at Hunter where she is active in the Newman Club. Her work during the war was primarily concerned with the preparation of special parts lists for Government projects and with checking change orders involving hundreds of drawings received from the Army Ordnance Department.

Miss Kaiser's home is in the upper Bronx on Pelham Bay and her interests are boating two-thirds of the year, swimming in summer, and skiing and skating in winter.



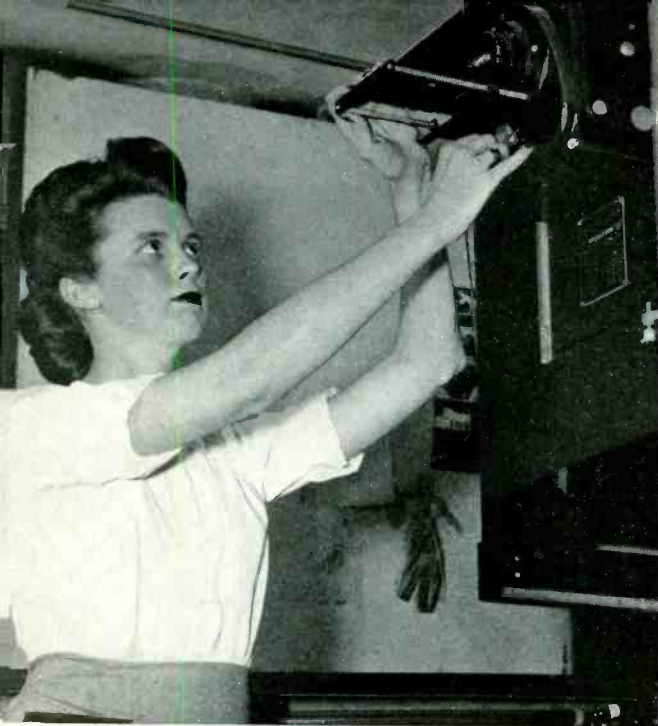

Evelyn O'Farrell adjusts the lens of the machine before making a photostat

ONE OF THE FIRST girl photostat operators at the Laboratories was EVELYN O'FARRELL, who had prepared for the work by a year's training as photostat assistant and by a course in photography. The two supplemented each other and were well chosen, for photostat work is a semi-mechanical process whereby a complete photographic operation—exposure, development and printing—is contained in one machine.

Daughter of the late James O'Farrell of the Plant Department, Evelyn came to the Blueprint Department on a temporary basis during the summer of 1941, after her graduation from Julia Richman High School, and in the fall was assigned on a permanent basis as a messenger. Her next promotion was to blueprint operator and from there she was transferred to the photostat group. Her outside activities are manifold and include volunteer nursing at the Beekman Street Hospital; studying photography; and attending language classes at the Philo-Celtic Society, an interest she acquired on a trip to Eire as a child.

* * * * *

HARRIET GREEN, the instructor of visible speech at the Laboratories, is a Federal licensed teacher of the hard-of-hearing. In her previous experience she had taught elementary and advanced phonetics on the staff at Brooklyn College where she had earned two degrees; she has also taught

speech and lip reading at the Lexington School for the Deaf and at the University of Indiana where she was in charge of the hearing program. While preparing for her Ph.D. at Columbia, Miss Green was a Research Assistant in the Department of Speech; her work was in speech pathology, speech correction and speech testing. She completes her dissertation shortly.

Miss Green has been a member of Transmission Research for more than two years, during which time she has been primarily concerned with working out methods of instruction and has been directly responsible for teaching the class of girls who are learning to read visible speech. She has also assisted in working out instructional procedures for training others to read it.

* * * * *

SELMA GRABER is training to assist in the instruction of visible speech in the Transmission Research Department. After graduation from Brooklyn College in '43 she joined Transmission Engineering as a Technical Assistant to do secret war work and was transferred from that group to work on visible speech about two years ago.

Miss Graber is a sports enthusiast whose calendar at this time of year is filled with hiking and football game engagements. Two evenings a week she attends educational psychology classes at Brooklyn College

SELMA GRABER



*Harriet Green as she explained visible speech
at a recent press demonstration*

with a view to obtaining her master's degree. She has lived with her grandparents in Brooklyn for many years and both they and her parents, who live in Middletown, Conn., have been annoyed because they have never had an inkling of her work at the Laboratories though until now they felt that working on West Street at the waterfront implied that she was doing espionage work.

* * * * *

ROSEMARY KENNEDY is a sister of BLAKE KENNEDY who is on military leave from the Laboratories. A graduate of Fontbonne Hall, she came to the General Service Department



ROSEMARY KENNEDY

in 1943 after having completed two years at Brooklyn College. Later she became a technical assistant on secret war work and now in the Transmission Research Department is training to assist in the instruction of visible speech. To supplement this training, she attends evening college at Columbia to study speech and education of the handicapped.

Miss Kennedy, the oldest of five children, appeared on children's broadcasting programs from the time she was seven until she was fourteen. She is interested in dramatics and has studied privately and in school. During a CBS television broadcast in November she participated in a demonstration of visible speech.



The Bell Chorus Christmas Concert

The Bell Chorus of New York will present its annual Christmas Concert on Thursday evening, December 13, at Times Hall, 240 West 44th Street, when a mixed chorus of seventy voices will sing under the direction of Thomas Richner. John Herrick, baritone, will be the guest artist for the concert this year.

Tickets may be purchased from HILDA MULLER, Room 1106 at West Street, Extension 1902.

Whippany Doll and Toy Committee

A Doll and Toy Committee has been formed at Whippany and for the first time members of the Laboratories there will participate in the Christmas custom, long established at other Laboratories' locations, of donating dolls, toys, or money to buy toys for underprivileged children. The committee at Whippany consists of representatives of the various groups with HARRIET FILMER as chairman, ANNE MARKS, treasurer, and BETTY ENGSTROM, secretary. Arrangements have been made to have the gifts sent to the nearby State Board of Children's Guardians in Morristown where the gifts will bring Christmas cheer to some of the eight hundred and fifty orphaned and underprivileged children being cared for at that institution.

News Notes

F. A. POTTER has been appointed to the RMA Transmitter Sub-Committee on transformers and reactors.

R. W. DEMONTE visited Haverhill in connection with general power apparatus problems.

B. L. CLARKE, Analytical Research Chemist, has resigned to become Director of Chemical Control at Merck & Company.

L. A. WOOTEN now has charge of the Chemical Analytical Department, in addition to his other duties.



P. S. DARNELL was at the Western Electric Co., Haverhill, to discuss questions pertaining to retard coils.

T. G. BLANCHARD spent four days in Nashville in connection with field complaints on K-2 Carrier System.

R. T. STAPLES visited the Point Breeze Plant of the Western Electric Company on cord development problems.

A. L. FOX and S. C. MILLER attended the regional outside plant engineering conference held at Baltimore.

A. P. JAHN visited the A.S.T.M. test plots located at Pittsburgh and State College, Pa., Sandy Hook, N. J., and Bridgeport, Conn., to make a semi-annual inspection of wire specimens that are undergoing atmospheric exposure tests.

R. H. COLLEY and C. H. AMADON, with the cooperation of representatives of the Bell Telephone Company of Canada, made a study of methods of controlling ant attack in the heartwood of northern cedar poles. While in Canada, Mr. Amadon attended a conference on pole inspection methods in Montreal. Dr. Colley also attended the Executive Committee meeting of the American Wood-Preservers' Association in Chi-

cago and held conferences on specifications for poles of miscellaneous conifers that are being prepared under the War Emergency Procedure of the A.S.A.

DR. COLLEY, in a short item in *Science* for October 6, is quoted on the necessity for conserving natural timber supplies because "war needs have depleted our timber supply to an extent that we do not fully realize."

A PAPER BY C. P. ROSE entitled *A 60-Kilowatt High-Frequency Transoceanic Radio-Telephone Amplifier* appeared in the October, 1945, *Proceedings of the Institute of Radio Engineers*.

MEMBERS of the Laboratories who are included in the Roster of I. R. E. Committee Members are: F. A. POLKINGHORN and LLOYD FSPENSCHIED, *Admissions*; G. W. GILMAN, F. B. LEWELLYN, E. L. NELSON, E. C. WENTE, G. W. WILLARD and WILLIAM WILSON (retired), *Board of Editors*; R. A. HEISING, *Constitution and By-Laws*; R. A. HEISING, *Executive*; W. H. DOHERTY and R. B. SHANCK, *Membership Solicitation Policy*; H. A. AFFEL, F. W. CUNNINGHAM, F. B. FERRELL, S. A. SCHELKUNOFF and E. K. VAN TASSEL, *Papers*; R. V. L. HARTLEY, R. A. HEISING and F. A. POLKINGHORN, *Sections*; R. A. HEISING, *Investments*; F. R. STANSEL, *Education*.

F. G. COLBATH was in Washington, D. C., on special announcing systems.

December Service Anniversaries of Members of the Laboratories

35 years	Margaret Fullerton
W. A. Bollinger	J. P. Kinzer
P. L. Wright	H. R. G. Tosch
	Rudolf Zimmerli
30 years	
F. C. Kahnt	
Anton Loder	
M. A. Weaver	
25 years	15 years
A. J. Daly	J. P. Coggins
C. L. DuBois	P. J. McGrory
Marion Kane	A. S. Windeler
R. J. Kent	
C. F. P. Rose	10 years
W. C. Somers	A. Kendall
	C. J. Kuhl
20 years	A. J. Lochner
E. I. Bulman	Irene Longley
J. H. Durnan	H. L. Messerschmidt
	Helen Murphy

H. J. SMITH's paper, *8,000 Pictures Per Second*, appeared in the September *Journal of the Society of Motion Picture Engineers*.

V. E. LEGG is author of the paper *Optimum Air Gap for Various Materials in Cores of Coils Subject to Superposed Direct Current* which appeared in the October *Electrical Engineering*.

Statistical Methods in Quality Control, Part V—Variations to Be Expected in Sampling is one of a series of articles prepared by the Personnel of the A.I.F.E. sub-committee on educational activities of which H. F. DODGE is a member. Part V appeared in the October *Electrical Engineering*.

J. R. TOWNSEND presented a paper, *Research and Materials*, before District committee meetings of the American Society for Testing Materials in Detroit and Chicago.

A PAPER entitled *Strength Properties of Adhesives*, by R. C. PLATOW of the Laboratories and Prof. A. G. Dietz of M.I.T., was presented at a symposium on Adhesives held at Atlantic City, New Jersey.

I. V. WILLIAMS and H. T. LANGABEER visited several Hartford telephone exchanges to observe aluminum bus bars.

I. V. WILLIAMS and L. W. KELSAY visited Point Breeze to discuss mounting studs for "F" type cable terminals.

T. C. CAMPBELL and C. H. AMADON went to Hawthorne in connection with requirements for wood for ladders.

J. H. PETTUS, in Appleton, Wisconsin, discussed the method of rewiring jacks in "R" type sealed test terminals used in "K" carrier systems.

H. H. SPENCER and G. W. MESZAROS visited the "L" carrier power plants from Atlanta, Ga., to Jacksonville, Fla., and made tests on power equipment. Mr. Spencer also visited the "K" carrier stations at Bowling Green and Salmins, Ky., to test the associated power equipment.

Please put your RECORD in the "Correspondence-Out" box when you are through with it so that it can be sent to a Serviceman's family.



A. B. Clark "rides" E. S. Wilcox (left) at his retirement dinner as P. W. Blye enjoys the fun

L. S. NEEB visited the Long Lines repeater station at Baldwin, Wisconsin, to study control equipment.

J. A. POTTER visited the Lincoln, Nebraska, plant of the Western Electric Company in connection with rectifiers that are used on the Navy Tone Link System. He also visited the Power Equipment Company in Detroit, where he discussed rectifiers for central office use.

H. W. BODE, C. E. SHANNON, J. W. TUKEY, H. NYQUIST, and S. B. WILLIAMS attended a conference on Advance Computation

Techniques held under the auspices of the Committee on Mathematical Tables and Other Aids to Computation, a sub-committee of the National Research Council, at M.I.T. on October 29 to 31. Mr. Williams described the method for numerical computation by the use of relays as illustrated in the general purpose computing system which is being developed by the Laboratories and units of which will be installed at Langley Field, Virginia, and the Aberdeen Proving Ground, Maryland.

J. C. OSTEN has been appointed a member of the Technical Committee of the New York Paint and Varnish Production Club.

W. J. CLARKE and J. B. DECOSTE visited the P. D. George Company in St. Louis to investigate new wire-enamel varnishes.

L. S. INSKIP, accompanied by J. M. Standing, Jr., and L. M. Harlow of O & E, recently visited Selma, Ala., to discuss protection problems with the Southern Bell Company in connection with rural wire telephone service under joint use conditions.



SEVERAL PAPERS by members of the Laboratories were presented before the Metropolitan Section of the American Physical Society at a meeting held in New York City on November 9 and 10. The papers were: *X-Ray Irradiation and Twinning in Quartz Crystals* by E. J. ARMSTRONG; *The Piezo-Electric Properties of Ammonium and Potassium Dihydrogen Phosphates* by W. P. MASON; *Orienting and Processing Synthetic Crystals* by W. L. BOND; *Growing Crystals from Aqueous Solutions* by A. N. HOLDEN; *Conduction of Ammonium Dihydrogen Phosphates* by E. J. MURPHY; *Study of "Optics" of Ultrasonic Wave Propagation in Ultrasonic Light Diffraction Cells* by G. W. WILLARD; and *A New Magnetomotive Force Gauge and Magnetic Field Indicator* by W. B. ELLWOOD.

H. W. HERMANCE and C. F. HEFFT recently conducted noise studies in several Western cities.

C. F. FORDHAM and J. LEUTRITZ, JR., visited Panama to study the effect of tropical climates on fire control equipment.

A. H. SCHIRMER was in Chicago at a meeting of the Electrical Committee regarding the revision of the National Electrical Code.

D. W. BODLE, J. J. MAHONEY, JR., D. G. NEUMAN and E. D. SUNDE have been in Atlanta, Ga., and in Tuscaloosa, Ala., where they conducted tests on the Atlanta-Meridian copper-jacketed cable to obtain data on lightning protection.

Obituary

J. J. CARLIN, a draftsman in the Apparatus Development Department, died on October 20. Mr. Carlin joined the Laboratories in 1942 and since then had been concerned with the mechanical design of apparatus for the Armed Forces, including underwater sound equipment, in the drafting group at Murray Hill. Before coming to the Laboratories he had been a draftsman for



J. J. CARLIN
1895-1945

the Linde Air Products Company and the Westinghouse Electric Corporation. In 1940 he studied at the Newark College of Engineering.

* * * * *

ROBERT POPE was in Pittsburgh to assist engineers with underground cable corrosion problems.

A REGIONAL OUTSIDE PLANT engineering conference held at the A. T. & T. Company recently was attended by R. A. HAINSLIP, C. D. HOCKER, A. L. RICHEY and F. F. FARNSWORTH.

A. J. CHRISTOPHER was in Chicago to discuss post-war condenser matters.



Index to Authors, Volume XXIII

A

ABRAHAM, L. G. . . . Four-Wire Switching for Crossbar Toll 151

B

BAILEY, A. B. . . . High-Gain Coaxial Antenna 62
BAKER, W. O. . . . Molecular Requirements for Synthetic Rubbers 97
BECK, F. Ribbon-Frame Camera 40
BLACK, H. S. . . . AN/TRC-6—A Microwave Relay 457
BLYE, P. W. Laying Field Telephone Wire by Airplane 145
BOMBERGER, D. C. . . . Servo-Mechanisms 409
BORER, A. J. To Leipzig and Back 291
BOWN, RALPH Outlook for Radio Relaying 365
BUCKLEY, O. E. . . . Bell Laboratories in the War (Separate Reprint
with July Issue)

C

CARR, J. A. Tactical Pole Lines 158
Tensioning Open Wire for J-Carrier Systems 8
COOKE, L. B. Voice of Ship Command (Battle Announcing System) 241

D

DURKEE, A. L. . . . Effect of Common-Channel Interference on
Frequency-Modulation Broadcasting 137
DUSTIN, G. E. . . . Junctor Grouping in Crossbar Toll 23

E

ERICKSON, J. R. . . . Military Telephone Instruments 194
EVELAND, E. H. . . . Cathode-Ray Bridge Detector 93

G

GILBERT, MRS. N. M. Meter Test Set 57

H

HAMILTON, B. P. . . . Early Bell System Telegraph Services 373
Single-Line Telegraphy in Early Bell System Practice 419
HIRD, F. S. Splice Detector for Army Field Wire 424
HULL, G. F., JR. . . . Measurement of Small Motions 86

I

INSKIP, L. S. Lightning-Protected Cable 248

K

KREISHER, C. Polyethylene-Disc Insulators for Coaxials 321

L

LANG, A. G.	Manual Calls in Crossbar Toll	101
LEUTRITZ, JOHN, JR.	Protecting Communications Equipment for the Tropics	105

M

McCORMACK, D. R.	Reproductions	202
McLEAN, D. A.	Chemically Stabilized Paper Capacitors	65
McMAHON, W.	Pigment Dispersion in a Synthetic Rubber Latex	471
MILLER, A. H.	6 BP Audiometer	464
MOODY, D. L.	Multi-Frequency Pulsing	466
MOONEY, R.	Telephone Plant in the Battle Zone	53

N

NORDAHL, J. G.	Tank Radio Set	1
------------------------	--------------------------	---

P

PEDERSEN, E.	Travelling Telephone Consultant	337
PHAIR, R. J.	Scratch Adhesion and Mar Testing of Organic Finishes	284
PIERCE, J. R.	Reflex Oscillators	287

S

SCHOTT, J. T.	Lookator	379
SHAPIRO, LILLIAN	Exploring Magnetic Fields	281
SHEATSLEY, P. W.	Coördinate Cross-Connectors for Automatic Toll Ticketing	29
SHIPLEY, F. F.	Nation-Wide Dialing	368
SMITH, R. G.	United Nations Conference Telephone Service	208

W

WADDELL, J. H.	Recording Camera for Testing Electrical Gun Directors	331
WALLDER, V. T.	Synthetic Rubber for Wire Insulation	209
WEHE, H. G.	Quartz Crystal Plating	476
WELLER, J. A.	Volume Limiter for Leased-Line Service	72
WILHELM, H. T.	Impedance Bridge with a Billion-to-One Range	89
WILLARD, G. W.	Air-Seal Test Set for Crystal Units	361
WILSON, R. H.	Self-Service Stockrooms	135

Y

YOST, L. A.	Combating Enemy Air Activity	415
---------------------	--	-----

Z

ZIEGLER, A. W.	Wire-Supported Crystals	140
------------------------	-----------------------------------	-----

Index to Subjects and Titles, Volume XXIII

A

Abstracts and Comments	
As an Editor Sees Us	372
Bell Telephone System Through the Years	128
By Walter S. Gifford, President, A T & T	
At Annual Meeting	201
From War to Peace	364
Telephone Business	172
General Ingles Lauds Bell System Committee	131
New Western Electric Hearing Aid, Model 63	295
Post-War Telephone Construction	324
Accident Prevention—Winter Driving Facts	18
Additional Manufacturing Facilities for Western Electric	435
Addresses	
President Gifford Addresses Stockholders	157
Adhesion Test	
Scratch Adhesion and Mar Testing of Organic Finishes . <i>Phair</i>	284
Advertising—Bell Laboratories Series	221
Air Power, Enemy Versus American	134
Air-Seal Test Set for Crystal Units	361
American Physical Society	
Harvey Fletcher Elected President	77
American Telephone and Telegraph Company	
Annual Report Excerpts	76
Plans for Two-Way Vehicular Telephone Service	293
Amplifiers	
BC-605 for Tank Radio Set	1
Voice of Ship Command (Battle Announcing System) . . <i>Cooke</i>	241
AN/TRC-6	
A Microwave Relay System	457
Press Demonstration of the AN/TRC-6	480
AN/TTCQ-1 Portable Operations Center	415
Anniversaries	
Telephone Anniversary Note	223
Western Electric Company's 75th Anniversary	12
Announcing Systems	
Voice of Ship Command (Battle Announcing System) . . <i>Cooke</i>	241
W. E. Battle-Announcing System on the <i>Iowa</i> (Picture)	52
Annual Meeting of the Frank B. Jewett Chapter Telephone	
Pioneers of America	299
Antennas—High-Gain Coaxial Antenna	62
Apparatus—Parts Molded and Cast at Murray Hill	161

Appointments—M. R. McKenney, General Patent Attorney	247
Audiometers—6 BP Audiometer <i>Miller</i>	464
Awards and Citations	
American Red Cross Citation	408
Bronze Star Medal Posthumously Awarded to	
Private Harry A. Malone	494
Captain Nils H. Anderson Receives Bronze Star	227
Captain O. F. Crankshaw Awarded Bronze Star	80C
Captain Reinberg Awarded Bronze Star and Purple Heart	80C
Charles A. Parker Honored by Award for	
Meritorious Civilian Service	297
Columbia University Presents the University Medal to	
William Fondiller	260
Commendatory Letter from Admiral E. J. King to	
Bell Telephone Laboratories Personnel	7
E. A. Jones and R. L. Shepherd Honored for Life Saving	446
E. L. Cochrane Commends Men and Women of	
Western Electric Company	245
E. L. Pederson Receives the Bronze Star Medal	433
F. J. Howe Awarded Bronze Star	396
Honorable Service Button	185
Lt. Col. Frank A. Parsons Awarded Bronze Star	173
Lieut. Col. Harry W. Holmlin Awarded Bronze Star	308
Lt. Col. McCann Receives the Order of the British Empire	305
Lt. Col. Thomas A. McCann Receives the Order of the	
British Empire (Picture)	401
Lieut. John Marrero, Jr., Awarded Bronze Star	268
Meritorious Civilian Award to Edward Montchyk	446
Meritorious Civilian Awards Presented to B.T.L. Men	387
M. J. Kelly and R. R. Williams Elected Members of the	
National Academy of Sciences	155
Morgan F. Hickey Receives the Croix de Guerre from	
General DuMay	266
Mrs. Lenora H. Doble of New Jersey Bell Receives	
Vail Medal	262
Raymond P. Chapman Receives Battlefield Commission in	
Italy	173
Southern New England Telephone Company Awarded the	
First "Certificate of Appreciation for Contribution to	
the War Effort"	272
Transportation Award	486
William B. Adam Awarded the Air Medal	266

B

Battle Announcing Systems (See Announcing Systems)

Battleships

Picture of Navy Battleship of <i>Iowa</i> Class	130
---	-----

Bazooka	
Rocket Researcher	37
Bell Laboratories Displays Its 1944 War Projects	384
Bell Laboratories in the War (Separate reprint with July issue)	<i>Buckley</i>
Bell System Network Facilities for F.M. Broadcasters	82
Blueprint Reproductions	<i>McCormack</i> 202
Bombs—Where the Flying Bombs Landed in Kent (Map)	19
Book Notices	
Fundamental Theory of Servo Mechanisms	<i>MacColl</i> 496
Network Analysis and Feedback Amplifier Design	<i>Bode</i> 496
Bullets—Western Electric Produces Gilding Metal for Bullet Jackets	222
Bureau of Publication	
Note on Personnel Changes	169
R. K. Honaman Appointed Director	481

C

Cables	
Signal Corps Salvage Depot in Paris (Picture)	261
Coaxial	
A T & T Program	216
Polyethylene-Disc Insulators for Coaxials	<i>Kreisher</i> 321
Faults and Fault Location—The Lookator	<i>Schott</i> 379
Insulation—Lightning-Protected Cable	<i>Inskip</i> 248
Repairs—Repairing Lines During a Jap Raid (Picture)	61
Spiral-4	
Lookator	<i>Schott</i> 379
Signal Corps Salvage Depot in Paris (Picture)	261
Travelling Telephone Consultant	<i>Pedersen</i> 337
Unscathed by Bombs	13
Splicing—War's Hunger for Telephone Plant Revealed in Tales Told by Splicers in Battle Zone	<i>Mooney</i> 53
Calibration—Meter Test Set	<i>Gilbert</i> 57
Cameras (See Also Fastax)	
High Speed	
High-Speed Movies Under Water	414
Ribbon-Frame Camera	<i>Beck</i> 40
Recording Camera for Testing Gun Directors	<i>Waddell</i> 331
Capacitors	
Chemically Stabilized Paper Capacitors	<i>McLean</i> 65
From a Japanese Field Telephone	262
Carrier Systems	
Five K-Carriers for United Nations Parley	218
Tensioning Open Wire for J-Carrier Systems	<i>Carr</i> 8
Cathode-Ray Bridge Detector	<i>Eveland</i> 93
Chemical Apparatus—Quartz Crystal Plating	<i>Wehe</i> 476
Chemical Laboratories	110

Chemically Stabilized Paper Capacitors	<i>McLean</i>	65
Circuits		
Splice Detector for Army Field Wire	<i>Hird</i>	424
Volume Limiter for Leased-Line Service	<i>Weller</i>	72
Coaxial Antenna, High-Gain	<i>Bailey</i>	62
Combating Enemy Air Activity	<i>Yost</i>	415
Conferences		
Conference for Speakers from Associated Companies		258
United Nations Conference Telephone Service	<i>Smith</i>	208
Contracts—Western Electric War Contracts Cancelled		386
Coördinate Cross-Connectors for Automatic Toll Ticketing	<i>Sheatsley</i>	29
Covers		
Field Artillery Radio Set		January
Engine Controls of Navy's Operational Flight Trainer		February
Red Cross War Fund		March
Quartz-Crystal Units of the Hermetically Sealed Type		April
Wire Laying by Plane		May
Russian Liaison Officer Speaks Via Radio Telephone in the Field		June
Navy "Hellcat" Taking Off on a Mission		July
Frank B. Jewett Chapter, Telephone Pioneers of America, Meet at Murray Hill		August
American Eagle		September
Coast Guard Helicopters		October
AN/TRC-6 Antenna		November
Laboratories Girls Hang the Christmas Wreath		December
Crossbar Systems		
Four-Wire Switching for Crossbar Toll	<i>Abraham</i>	151
Juncitor Grouping in Crossbar Toll	<i>Dustin</i>	23
Manual Calls in Crossbar Toll	<i>Lang</i>	101
Multi-Frequency Pulsing	<i>Moody</i>	466
Crystals		
Air-Seal Test Set for Crystal Units	<i>Willard</i>	361
Historic Firsts:		
Wire-Mounted Crystals.		246
Zero-Temperature-Coefficient Quartz Crystals		70
Plating	<i>Wche</i>	475
Wire-Supported Crystals	<i>Ziegler</i>	140

D

Daylight, Amount of		11
Deafness—Visible Speech Demonstrated	<i>Potter</i>	483
Dialing, Nation-Wide	<i>Shipley</i>	368
Directory, Laboratories' Telephone		387
Dispersion		
Pigment Dispersion in a Synthetic Rubber Latex	<i>McMahon</i>	471
Drawings, Reproduction of	<i>McCormack</i>	202

E

Early Bell System Telegraph Services	<i>Hamilton</i>	373
Education—Part-Time Post-Graduate Study Plan		387
Effect of Common-Channel Interference on Frequency- Modulation Broadcasting	<i>Durkee</i>	137
Electric Networks		
Historic Firsts: Balancing Networks		412
Employees' Benefit Committee, Report of		108
Equipment		
Laboratories Displays Its War Projects		384
Laboratories Rises to an Emergency		164
To Leipzig and Back	<i>Borer</i>	291
Travelling Telephone Consultant	<i>Pedersen</i>	337
Espenschied, Lloyd, Honored		47
Exhibits and Demonstrations		
Bell Laboratories Displays Its 1944 War Projects		384
Exploring Magnetic Fields	<i>Shapiro</i>	281

F

Fastax—High-Speed Movies Under Water		414
Fellowships, Frank B. Jewett		111
Field Telephone		
In Use in France (Picture)		84
Japanese (Picture)		114
Finishes, Organic		
Scratch Adhesion and Mar Testing of Organic Finishes	<i>Phair</i>	284
Fire Alarm System at Murray Hill		128
First Aid		
History of Training at the Laboratories		182
Flight Trainer		
Operational Flight Trainer Demonstrated		33
Ten Minutes Over the Patuxent River		46
For Valor and Service—Service Ribbons		133
Four-Wire Switching for Crossbar Toll	<i>Abraham</i>	151
Frank B. Jewett Chapter of Telephone Pioneers Inspects		
Murray Hill Laboratories		303
Frank B. Jewett Fellowships		111
Frequency Modulation		
Bell System Network Facilities for Frequency Modulation		
Broadcasters		82
Effect of Common-Channel Interference on Frequency Modulation Broadcasting	<i>Durkee</i>	137
FT-237 Mounting—Tank Radio Set	<i>Nordahl</i>	1
Fungus		
Jungle Laboratory		329
Protecting Communications Equipment for the Tropics	<i>Leutritz</i>	105

G

Gages—Pit Gauge for Ceramic Tubes	377
German Communications, Survey of	431
“GI Joe With a Wire in Each Hand”	45
Gilding Metal Produced by Western Electric for Bullet Jackets	222
Greater New York Fund	18
Gun Director, Recording Camera for Testing <i>Waddell</i>	331

H

Harrison, William H., Returns to A T & T	376
Headsets—Military Telephone Instruments <i>Erickson</i>	194
Hearing Aid, Western Electric Model 63	295
High-Gain Coaxial Antenna <i>Bailey</i>	62
High-Speed Movies Under Water	414
High-Speed Submarine Telegraphy Historic Firsts: High-Speed Submarine Telegraphy	156
Historic Firsts: Balancing Networks	412
Copper-Oxide Modulators	200
High-Speed Submarine Telegraphy	156
The Heising Modulator	6
The Peanut Tube	336
Wire-Mounted Crystals	246
Zero-Temperature-Coefficient Quartz Crystals	70
Holidays Restored	388
Honaman, R. K., Appointed Director of Publication	481
Honorable Service Button	185
Humidity—Jungle Laboratory	329

I

Identifier—Coördinate Cross-Connectors for Automatic Toll Ticketing <i>Sheatsley</i>	29
Impedance Bridge With a Billion-to-One Range <i>Wilhelm</i>	89
Information Center System SCS-5 <i>Yost</i>	415
Institute of Radio Engineers F. B. Llewellyn Elected President	487
Insulation Chemically Stabilized Paper Capacitors <i>McLean</i>	65
Synthetic Rubber for Wire Insulation <i>Wallder</i>	209
Insulators, Polyethylene-Disc, for Coaxials <i>Kreisher</i>	321
Interferometers and Interferometry Measurement of Small Motions <i>Hull, Jr.</i>	86
Interim Research Body of Civilian and Military Scientists	86

J

Japanese Field Telephone Picked Up at Saipan	114
Juncture Grouping in Crossbar Toll <i>Dustin</i>	23
Jungle Laboratory	329

L

Laboratories, Chemical	110
Laboratories' Leaders Talk to Associated Company Men on Loan	429
Laboratories' Telephone Directory	387
Laboratories, The, Rises to an Emergency	164
Laying Field Telephone Wire by Airplane	<i>Blye</i> 145
Leipzig, Trip to	<i>Borer</i> 291
Lightning-Protected Cable	<i>Inskip</i> 248
Line Construction—Tactical Pole Lines	<i>Garr</i> 158
Llewellyn, F. B., Elected President of I.R.E.	487
Long Distance Rates Reduced	259
Lookator, The	<i>Schott</i> 379
Loudspeakers—Military Telephone Instruments	<i>Erickson</i> 194

M

M12 (see Rocket Launcher)	
Magnetic Fields, Exploring	<i>Shapiro</i> 281
Manual Calls in Crossbar Toll	<i>Lang</i> 101
Mar Test of Organic Finishes	<i>Phair</i> 284
Materials	
Salvage	
Huge Signal Corps Salvage Depot in Paris	261
Signal Equipment Being Salvaged at Front	20
Testing	
Jungle Laboratory	329
McKenney, M. R., Appointed General Patent Attorney	247
Measurement of Small Motions	<i>Hull, Jr.</i> 86
Measurements and Measuring Instruments	
Cathode-Ray Bridge Detector	<i>Eveland</i> 93
Meter Test Set	<i>Gilbert</i> 57
Microphones—Military Telephone Instruments	<i>Erickson</i> 194
Military or Merchant Marine Leaves of Absence	79
Military Telephone Instruments	<i>Erickson</i> 194
Mills, John, Retires	165
Modulators—Historic Firsts:	
Copper-Oxide Modulators	200
The Heising Modulator	6
Moisture Proofing—Protecting Equipment for the Tropics	<i>Leutritz</i> 105
Molding and Casting Metals at Murray Hill	161
Molecular Requirements for Synthetic Rubbers	<i>Baker</i> 97
Motion Picture Films, Catalog of Bell System's	233
Multi-Frequency Pulsing	<i>Moody</i> 466
Murray Hill	
Fire Alarm System	128
Laboratories to Be Expanded	215
Main Service Piping (Picture)	49
Molding and Casting Metals	161

N

Nation-Wide Dialing	<i>Shipley</i>	368
Naval Operations and Telephones		130
Navy Training Devices—Operational Flight Trainer		33
Networks, Balancing		
Historic Firsts: Balancing Networks		412
New York Telephone Company, Five-Year Construction		
Program for		260
Nimitz, Admiral C. W., Discusses Morale		71

O

Operational Flight Trainer Demonstrated		33
Operations Centers TC-15	<i>Yost</i>	415
Oscillators, Reflex	<i>Pierce</i>	287
Outlook for Radio Relaying	<i>Bown</i>	365
Overseas Radio-Telephone Service		497

P

Packing and Shipping		
Laboratories Rises to an Emergency		164
Parkinson, D. B., Visits Germany		427
Part-Time Post-Graduate Study Plan		387
Patuxent River—Flight-Crew Trainer Demonstration		46
Pentode for the Battle Front in Three Days		78
Photostats—Reproductions	<i>McCormack</i>	202
Pigment Dispersion in a Synthetic Rubber Latex	<i>McMahon</i>	471
Pioneers Add 14,000 Members in 1944		47
Pioneers at Murray Hill Laboratories		301
Pipes and Piping at Murray Hill (Picture)		49
Pit Gauge for Ceramic Tubes		377
“Plane With a Thousand Eyes”		219
Plating, Vapor, of Quartz Crystals	<i>Whe</i>	476
Plywood Radio Masts for Signal Corps		22
Poles—Tactical Pole Lines	<i>Carr</i>	158
Polyesters—Molecular Requirements for Synthetic Rubbers	<i>Baker</i>	97
Polyethylene-Disc Insulators for Coaxials	<i>Kreisher</i>	321
Press Demonstration of the AN/TRC-6		480
Protecting Communications Equipment for the Tropics	<i>Leutritz</i>	105
Public Relations Conference at Murray Hill		485
Pulsing, Multi-Frequency	<i>Moody</i>	466

Q

Quartz Crystal Plating	<i>Whe</i>	476
----------------------------------	----------------------	-----

R

Radar and the Bell System		325
Radiation, Solar—Microwave Radiation From the Sun		132

Radio

Broadcasting—Effect of Common-Channel Interference on	
Frequency-Modulation Broadcasting	<i>Durkee</i> 137
Development—Outlook for Radio Relaying	<i>Bown</i> 365
Interference—Effect of Common-Channel Interference on	
Frequency-Modulation Broadcasting	<i>Durkee</i> 137
Masts—Plywood Radio Masts for Signal Corps	22
Receivers—BC-603 for Tank Radio Set	<i>Nordahl</i> 1
Relaying, Outlook for	<i>Bown</i> 365
Sets, SCR 508, -528, -538, for Tank Radio Set	<i>Nordahl</i> 1
Stations—Portable Radio Stations	83
Transmission—Ultra-Short-Wave	
Radio Relay Sites Announced	217
Transmitters, BC-604, for Tank Radio Set	<i>Nordahl</i> 1
Ultra Short Wave	
AN/TRC-6—A Microwave Relay	<i>Black</i> 457
Outlook for Radio Relaying	<i>Bown</i> 365
Press Demonstration of the AN/TRC-6	480
Radio Pinch-Hits for Telephone Lines	17
Radio-Telephone Service, Overseas	497
Radio-Telephone	
Overseas Service Resumed	297
Radio Pinch-Hits for Telephone Lines	17
On Automobiles	
A T & T Announces Plans for Two-Way Vehicular	
Telephone Service	293
Radio-Telephone Service Resumed at Low Rates	434
Recording Camera for Testing Electrical Gun Directors	<i>Waddell</i> 331
Red Cross War Fund	79
Reflex Oscillators	<i>Pierce</i> 287
Rehabilitating a Telephone System	<i>Glezen</i> 255
Relay Stations	
Radio Relay Sites Announced	217
Reproductions	<i>McCormack</i> 202
Research—Interim Research Body of Civilian and Military	
Scientists	86
Ribbon-Frame Camera	<i>Beck</i> 40
Rocket Launcher M12	37
Rubber, Artificial	
Molecular Requirements for Synthetic Rubbers	<i>Baker</i> 97
Pigment Dispersion in a Synthetic Rubber Latex	<i>McMahon</i> 471
Synthetic Rubber for Wire Insulation	<i>Wallder</i> 209

S

Salvage—Signal Corps Depot in Paris	261
Scientists From India Visit Murray Hill	80
Scratch Adhesion and Mar Testing of Organic Finishes	<i>Phair</i> 284
Screws, Testing the Life of Adjusting	378

Sealing		
Air-Seal Test Set for Crystal Units	<i>Willard</i>	361
Synthetic Rubber Pressure-Seal		32
Self-Service Stockrooms	<i>Wilson</i>	135
Service "On the Double" for Soldiers		252
Service Ribbons for Valor and Service		133
Servo-Mechanisms	<i>Bomberger</i>	409
Signal Equipment Being Salvaged at Front		20
Single-Line Telegraphy in Early Bell System Practice	<i>Hamilton</i>	419
6BP Audiometer	<i>Miller</i>	464
Speech, Visible		
Edgar Bloom First Deaf Student of Visible Speech		485
Visible Speech Demonstrated		483
Spiral-Four Unscathed by Bombs		13
Splice Detector for Army Field Wire	<i>Hird</i>	424
Stamp Club Contributes to Hospital Visitation Plan		82
Stockrooms, Self-Service	<i>Wilson</i>	135
Survey of German Communications		431
Switching		
Four-Wire Switching for Crossbar Toll	<i>Abraham</i>	151
Juncter Grouping in Crossbar Toll	<i>Dustin</i>	23
Synthetic Rubber for Wire Insulation	<i>Wallder</i>	209
Synthetic Rubber Pressure-Seal		32

T

Tactical Pole Lines	<i>Carr</i>	158
Tank Radio Set	<i>Nordahl</i>	1
Technical Observer for Signal Corps (see Travelling Telephone Consultant)		
Telegraph		
Early Bell System Telegraph Services	<i>Hamilton</i>	373
Historic Firsts: High-Speed Submarine Telegraphy		156
Single-Line Telegraphy in Early Bell System Practice	<i>Hamilton</i>	419
Telephone		
Calls		
Manual Calls in Crossbar Toll	<i>Lang</i>	101
Service "On the Double" for Soldiers		252
Construction		
Five-Year Construction Program for New York Telephone Company		260
Post-War Telephone Construction		324
Holland		
Ten Years Will Be Required to Repair Damage		304
Military Telephone Instruments	<i>Erickson</i>	194
On Ships		
Naval Operations and Telephones		130
Plant, Storm Damage		
Radio Pinch-Hits for Telephone Lines		17

Telephone (continued)

Rates		
Long-Distance Rates Reduced		259
Restoration of Service		
Rehabilitating a Telephone System	<i>Glezen</i>	255
Service		
For Returning Soldiers' Use		21
For the Fleet		496
Telephone Service to Three European Countries		259
Sets, Japanese		
Japanese Field Telephone Picked Up at Saipan		114
Test Sets, KS-10176		
Air-Seal Test Set for Crystal Units	<i>Willard</i>	361
Telephone Pioneers of America		
Annual Meeting of the Frank B. Jewett Chapter		299
Elect Randolph Eide President		487
Pioneers Add 14,000 Members in 1944		47
Television, Lloyd Espenschied Honored for Work on		47
Ten Minutes Over the Patuxent River		46
Tensioning Open Wire for J-Carrier Systems	<i>Carr</i>	8
Test Sets, Meter	<i>Gilbert</i>	57
Testing the Life of Adjusting Screws		378
Ticketing, Automatic, Coördinate Cross-Connectors for	<i>Sheatsley</i>	29
Time and Weather		167
Toll Systems		
Juncture Grouping in Crossbar	<i>Dustin</i>	23
Manual Calls in Crossbar Toll	<i>Lang</i>	101
Travelling Telephone Consultant	<i>Pedersen</i>	337
Toll Ticket Recording Devices at Culver City, Calif.		233
Trainer, Flight-Crew		46
Transmission Measurements		
Cathode-Ray Bridge Detector	<i>Eveland</i>	93
Transpositions		
Tensioning Open Wire for J-Carrier Systems	<i>Carr</i>	8
Travelling Telephone Consultant	<i>Pedersen</i>	337

U

Understanding the Discharged Veteran		170
United Nations Conference		
Five K-Carriers for United Nations Parley		218
Telephone Service	<i>Smith</i>	208

V

Vacuum Tubes		
Historic Firsts: The Peanut Tube		336
Pentode for the Battle Front in Three Days		78
V-E Day at the Laboratories		220

Veterans	
Understanding the Discharged Veteran	170
Vibration—Machine for Determining Ability of War	
Products to Withstand Vibration (Picture)	184
Victory Depends on Good Communications	84
Visible Speech Demonstrated	483
Voice of Ship Command <i>Cooke</i>	241
Volume Limiter for Leased-Line Service <i>Weller</i>	72

W

War Fund Drive, National	388
Warships	
Naval Operations and Telephones	130
Weapons—Interim Research Body of Civilian and Military	
Scientists	86
Wear Test—Testing the Life of Adjusting Screws	378
Weather Bureau—Time and Weather	167
Western Electric Company	
Additional Manufacturing Facilities in Chicago	435
Plant at Allentown, Pa.	496
Produces Gilding Metal for Bullet Jackets	222
Resumes Operation in Paris	15
75th Anniversary	12
War Contracts Cancelled	386
Winter Driving Facts	18
Wire Laying by Airplane <i>Blye</i>	145
Wire-Supported Crystals <i>Ziegler</i>	140

Z

Zero-Temperature-Coefficient Quartz Crystals, Historic Firsts	70
---	----