

V. L. JOHNSON
Switching
Development

COLD-CATHODE-TUBE TEST SET



Fig. 1—Cold-cathode-tube test set in use in the systems laboratory

In the panel and crossbar dial systems, many timed periods are required to permit certain circuit operations to be carried out, and to give an alarm if these operations are not completed by the end of the period. In the past, these time intervals have been provided by power-driven, cam-actuated interrupters. With the introduction of the No. 5 crossbar system, however, the power-driven interrupters were replaced by circuits employing cold-cathode tubes. Time delays are obtained by utilizing the time required to charge a capacitor in series with a high resistance. The potential on the capacitor is applied to the control anode of the tube, and when this potential builds up to a value sufficient to cause the tube to ionize, a relay in the tube circuit operates.

The voltage at which individual cold-cathode tubes will ionize and conduct current varies considerably, resulting in corresponding variations in the time delay obtained with different tubes. To prevent excessive time variations that would result from the use of tubes with ionization voltages greater or less than the specified tolerances, a test set has been developed for checking these tubes. The principal equipment of the test set consists of a voltmeter,

a milliammeter, potentiometers, keys, and sockets for mounting the various types of tubes to be tested, all of which are encased in a standard metal test set box as shown in Figures 1 and 5. Jacks provide access for

reduce the current to zero. To measure the drop across the starter gap, the SG key is moved to the DROP position so that the voltmeter is connected directly across the starter gap. In either position, the potential

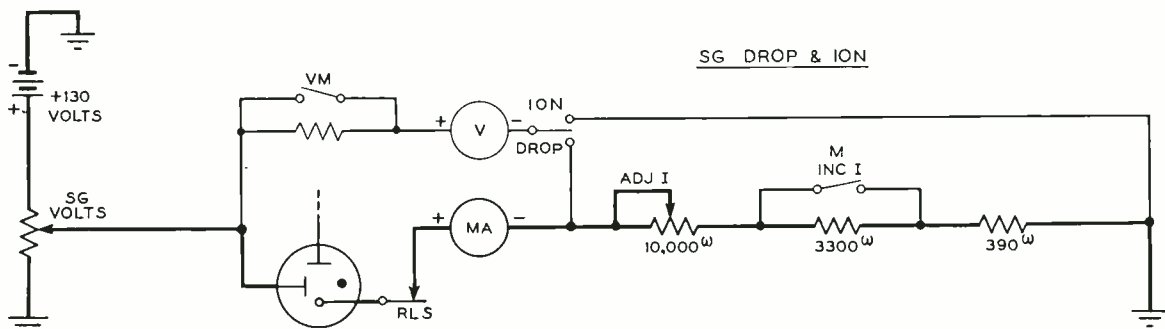

Fig. 2—Test circuit as established for testing the starter gap

testing wired-in tubes and for connecting to the necessary testing battery by patching to frame jacks furnishing the required -48 and $+130$ -volt potentials. Binding posts are provided for making direct connections to tubes with lead-in wires.

Most of the testing connections are set up by operating either of two keys to one or the other of two positions. The SG key is used for testing the starter gap, and the AC key for the main anode gap. With triodes, tests may be made on the starter and anode gap successively, but for diodes only the AC key is used. Each of these keys has an ionization test position marked ION, and voltage drop test position marked DROP. Figure 2 shows the circuit established for testing the starter gap. The only change made by moving the SG key from the ION to the DROP position is to change the voltmeter connections so as to read the potential across the starter gap rather than that from the starter anode to ground.

With the SG key in the ION position, the SG-v potentiometer is turned until the tube starts to pass current, which will be indicated by a sudden increase in the reading of the milliammeter. The potential to ground on the starter anode may then be read on the voltmeter after the RLS key has been operated to extinguish the tube and

of the starter anode to ground may be adjusted to the desired value. The drop across the starter gap cannot be measured on tubes that are permanently wired in a circuit, since the anode is connected directly to positive battery, and the anode current would prevent such measurements.

Current through the tube for the starter and anode drop tests may be adjusted by the ADJ-I potentiometer. When more current is required than may be obtained with this potentiometer, the M key may be moved to the INC-I position, thus shorting out a 3,300-ohm resistor in the cathode circuit. There are thus two ranges over which the current may be adjusted, and over both ranges the ADJ-I potentiometer is used to obtain the exact current required. The voltmeter also has two ranges: 100 and 200 volts. Normally, the 200-volt range is connected in, but by operating the VM key, a resistor in series with the voltmeter is shorted out to give the 100-volt range.

When the AC key is operated to the ION position, the circuit is as shown in Figure 3. Normally, the anode is connected directly to the $+130$ -volt battery, and the cathode—through the milliammeter and the cathode resistor—is carried by way of the AC-v potentiometer to the -48 -volt battery. This latter potentiometer will be adjusted to the

non-ionizing potential across the anode gap, and the tube should not ionize, since this is a non-operating test on the tube. For testing voltage-regulator tubes, the vr key may be operated, which changes the connection of the anode from the 130-volt battery to the sg-v potentiometer, and thus gives wide control over the anode potential. On these tubes, the potential should be adjusted to the point where the tube ionizes.

When the ag key is moved to the DROP position, the circuit is as shown in Figure 4. This is similar to Figure 3, except that the voltmeter is connected directly across the anode gap, and the anode is always connected directly to the +130-volt battery. Operation of the m key to the BK-DN position, however, will connect the sg-v potentiometer directly to the starter anode, and

thus ionize the tube when the potential across the anode gap is not sufficient to do so.

This m key closes a second contact in the BK-DN position that gives a transient voltage to start ionization. This key is used only on vr two-element tubes to insure a potential across the anode gap high enough to ionize the tube. The arrangement is shown in both Figures 3 and 4. With the m key normal, the c2 capacitor is charged to +130 volts through a large resistor. When the m key is moved to the BK-DN position, this capacitor is suddenly discharged and thus momentarily increases the voltage across the anode and cathode gaps and causes the tube to ionize. When the key is restored to normal, the capacitor will slowly recharge through the 100,000-ohm resistor.

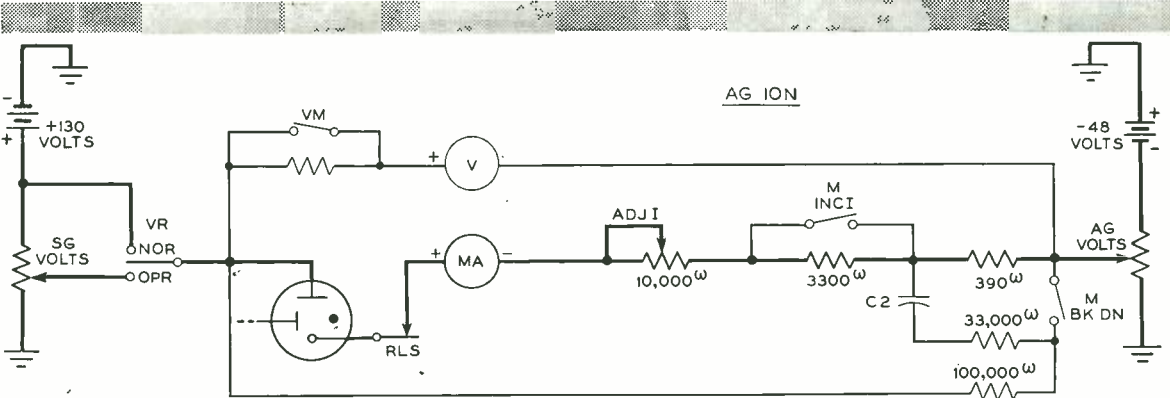

Fig. 3—Test circuit with key in "ION" position

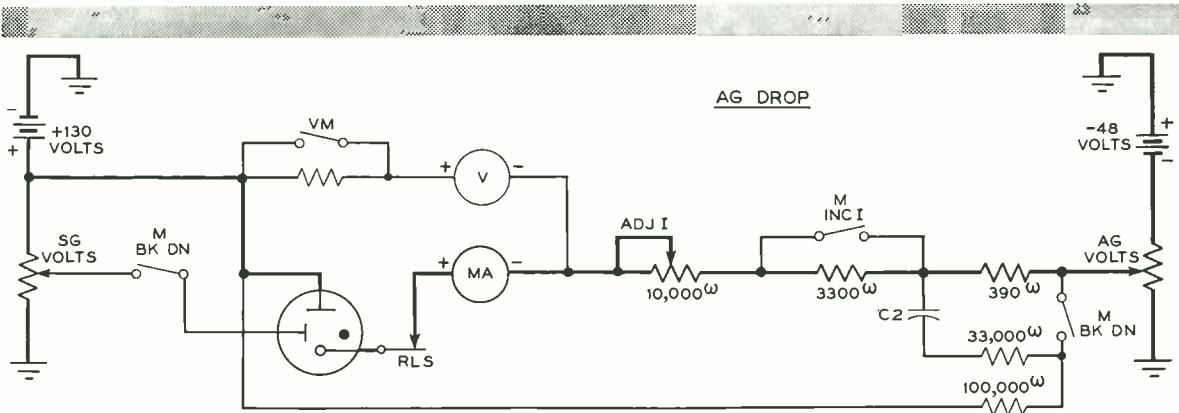

Fig. 4—Test circuit with key in "DROP" position

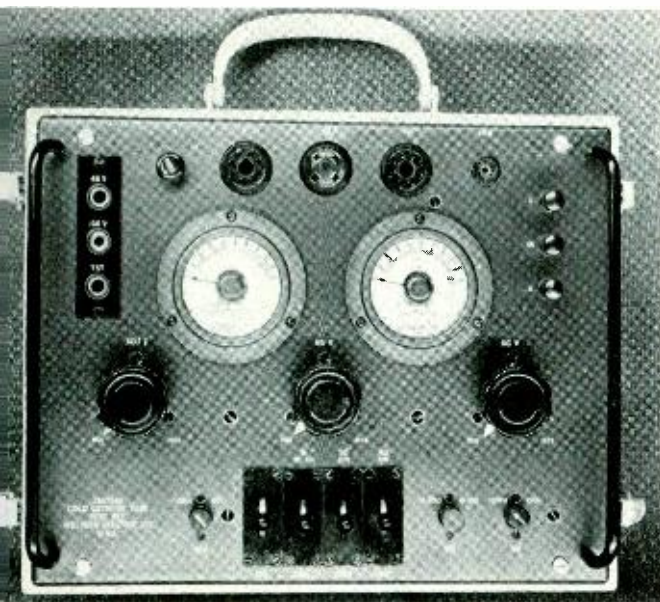

Fig. 5—Front view of cold-cathode-tube test set

These various keys and controls are evident in Figure 5, which shows the front of the test set. Across the top are four receptacles for various types of tubes, while at the upper right are binding posts for connecting to tubes with lead-in wires. At the

upper left are jacks for battery connections and also a test jack for connection to wired-in tubes.

In a line directly beneath the two indicating meters are the three potentiometers already referred to. Beneath the central potentiometer are four keys: the AC, SC, M, and RLS keys, reading from right to left. The latter key opens the cathode circuit and thus de-ionizes the tube preparatory to making a new test and also permits reading ionizing voltages. The VR and VM keys are at the right of this central group, while at the left is a reverse key that reverses the connections to the cathode and starter anode for testing bi-directional three-element tubes.

As used in the new No. 5 crossbar offices, the set may be kept at some convenient location and tubes carried to it for testing, or the set may be carried to the frames where the tubes are located when tests are to be made on tubes that are permanently wired into the circuit. Figure 1, on page 481, shows a test of this latter type being made in the No. 5 crossbar laboratory. Complete with cords, the set weighs only twelve pounds and thus is readily carried about a central office as needed.



THE AUTHOR: V. L. JOHNSON received the degree of B.S. in Electrical Engineering from the University of Maine in 1923, and joined the Laboratories in July of that year. After a short period testing manual circuits, he transferred to the relay design group, where he remained until 1940. He then transferred to the group testing automatic ticketing circuits for step-by-step offices. During the war, he prepared maintenance manuals and designed test circuits for electrical anti-aircraft gun directors. After the war, he transferred to a group testing special circuits for No. 1 crossbar. He has been associated with the testing of the No. 5 crossbar system since the beginning of that project.

GERMANIUM VARISTORS

Crystal detectors, preferably called point-contact rectifiers, first came into prominence in the early days of radio, and galena, carborundum and silicon were materials widely used at that time. They were unstable and erratic in their behavior, but their use was soon made unnecessary by the

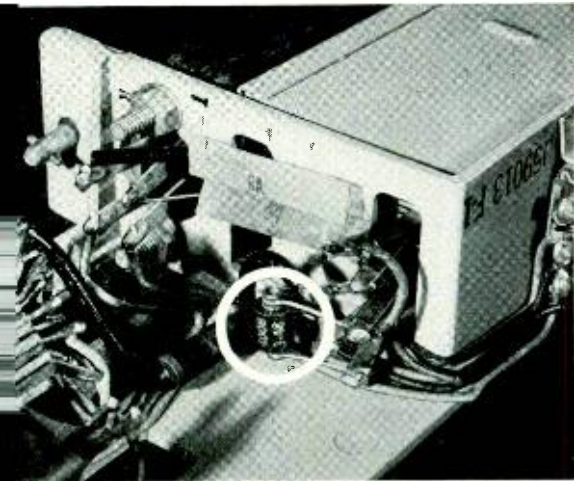

Fig. 1—A central-office trunk circuit of the 555 PBX showing a 400B germanium varistor used to reduce the potential on the cord sleeve when the plug is removed from the jack

only $\frac{1}{4} \times \frac{1}{2}$ inch, as shown in Figure 1, it has been made in four forms known as the 400A, 400B, 400C, and 400D varistors.

Each such unit consists of a germanium wafer with a specially prepared surface on which contact is made with a pointed tungsten wire. This unit is assembled in a small molded case, as shown in Figure 2, and provided with nickel wire leads for connecting it in circuits. This design is an outgrowth of a wartime development that had for its objective a rectifying element less susceptible to electrical burn-out than the silicon rectifier which was widely used as a microwave converter in radar equipment. The germanium unit proved unsuitable for use at frequencies above a few hundred megacycles, but for lower frequencies it had useful and unusual properties, the outstanding of which was its ability to withstand reverse potentials of more than 50 volts in a single element—in some cases more than 200 volts.

In contrast with many of the earlier point-contact rectifiers, these units are mechanically rugged, relatively stable, reproducible in electrical characteristics, and do not depend on finding a sensitive spot for the point contact. The tungsten wire that makes contact with the germanium wafer is given its shape by the process known as

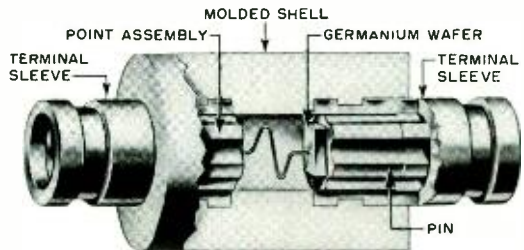

Fig. 2—Cut-away view of a 400 type varistor

*RECORD, April, 1948, page 152.

electropointing.* The four types are all mechanically alike but different in their electrical characteristics. A typical voltage-current characteristic for the 400A varistor is shown in Figure 3. Although their reverse resistance is not as high as that of vacuum-tube diodes, their forward resistance is in general lower and, unlike the diode, which has a small space current at zero anode voltage when the cathode is hot, the current of the germanium varistor is zero with zero impressed voltage, thus permitting the varistor to replace the diode in many circuits.

A partial list of circuit uses would include rectifiers for many purposes, second detectors, slicers, limiters and clippers, pulse generators, modulators and demodulators, and as non-linear elements for compressors, expandors, and automatic volume control circuits. One of the largest scale uses at the present time is in the voice-frequency tone-signaling unit used for toll line dialing. Here the varistors are used to delay the operate and release times of certain relays, to prevent a back-up of current where several relays are operated from a

*RECORD, May, 1948, page 205.

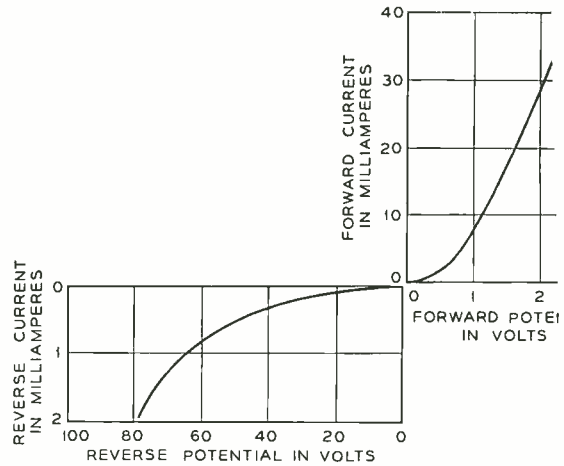

Fig. 3—Voltage-current characteristic of the 400A varistor

common ground, and to act as half-wave rectifiers. Other uses are in rural power line carrier as a half-wave rectifier, and in the 555 PBX to limit the inductive voltage surge resulting from interruptions of the current in the sleeve relay.



HOW FAST DO YOU DIAL?

Just as the wear in an automobile depends on the rate of acceleration and deceleration as well as on the maximum speed, so does the wear in a dial mechanism. In the test, a stylus plots the dialing action of typical subscribers. The findings help design life tests which subject dial mechanisms to the kind of wear they will receive in service.

P. A. REILING
Transmission
Research

COMPANDING IN PCM

In the 96-channel pulse code modulation system,* samples of each channel are taken at a rate of 8,000 a second, and each sample is assigned a code of on-or-off pulses for transmission. The same code, however, is assigned to any amplitude of the sample falling within a small range of values called a quantum. At the receiver, each code is translated into a sample whose value is that of the middle of the quantum that the code represents. As a result, the size of the reproduced sample is not in general exactly the same as that of the original sample. Because of this, the reproduced signal contains a form of distortion that is heard as background noise, and is commonly referred to as quantizing noise. How great this quantizing noise will be depends on the size of the quantum. To reduce this size—if all the quanta are equal—the number of codes must be increased, but since the complexities of the circuit increase with the number of codes, it is desirable to keep this number as small as is consistent with satisfactory transmission.

How disturbing the noise on a circuit may be depends not on the absolute value of the noise voltage, but on its value relative to that of the speech voltage. Even though the quantizing noise is large enough to be quite noticeable at low-level speech, it tends to become negligible at the higher speech levels because its value relative to the signal becomes less. It is thus possible to make the quanta at high levels of speech much larger than those at low levels without increasing the apparent quantizing noise. By varying the sizes of the quanta, therefore, using large quanta at high-level speech and small ones at low-level speech,

a given total number of quanta will introduce less noise than if the same number were all of the same size.

This variation in size is secured by companding—compressing the signal before coding, and expanding it after decoding. Although companding is thus used to decrease noise in a PCM system, it is not used in the same way as on long-wave transoceanic circuits,* and on some open-wire carrier circuits where companders are also used for noise reduction. In the latter systems, the input speech wave at the transmitter is compressed so that the higher levels will not overload the transmitter, and so that the lower levels will be safely above the noise over the transmission path. In such service, the companders are not instantaneous in their actions; they act at syllabic rates, and are controlled by rectification of the input wave. In a PCM system, on the other hand, noise over the transmission path is removed by the regeneration of the code pulses. The companders, which are instantaneous rather than syllabic in their action, serve to reduce the quantizing noise which is a by-product of the pulse coding process.

The positions of the compressor and expander in the 96-channel PCM system are indicated at the left of Figure 1. At the transmitting end, a group of twelve electronic gates admit 10.5-microsecond specimens of the twelve channels one after the other directly to the compressor. Since the time between the end of the specimen of one channel and the beginning of that of the next is essentially zero, the compressor receives signal continuously, but there is a discontinuity at each transition point be-

*RECORD, September, 1948, page 364.

*RECORD, December, 1934, page 98.

cause the speech waves in the twelve channels are independent of each other, and when one channel is at low level, the adjacent one may be at high level.

To illustrate the action of the compandor, it will be simpler to consider only one channel, say channel 2, as is done at the

right of Figure 1. To further simplify the explanation, it is assumed that the input to channel 2 is a pure sine wave, as shown along the upper line of the illustration. The successive 10.5-microsecond specimens of this channel admitted to the compressor are indicated on line B. Each of these speci-

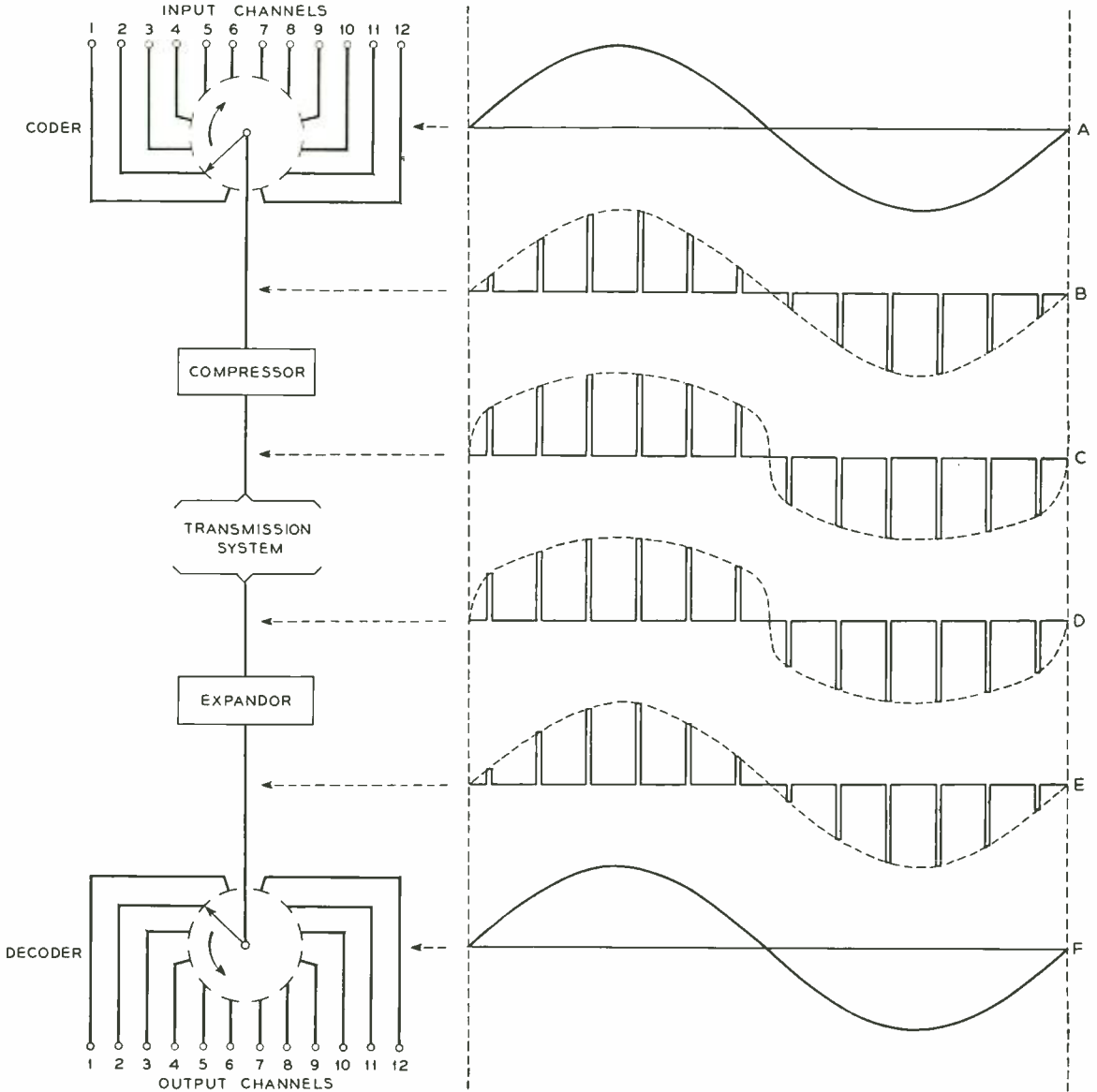

Fig. 1—Transmission path of a twelve-channel group, at the left, and signals at various stages for a single-frequency tone input to one channel, at the right

ments conforms to the input wave during the 10.5-microsecond period, and between successive specimens the compressor will receive corresponding specimens from the eleven other channels.

The essential elements of the compressor are shown in Figure 2. Besides the shunt and series resistors, it contains two varistors oppositely poled and bridged across the circuit. One passes current when the potential on the upper side of the circuit is positive and the other when the lower is positive. Up to some value of voltage, these varistors pass very little current, but beyond this voltage the current through them varies rapidly with the voltage. Up to this critical value of voltage, therefore, the loss introduced by this circuit is nearly constant, but above this voltage it increases as the voltage increases. A linear amplifier at the output of the circuit makes up for the loss in level without destroying the differential loss introduced by the compressor. To prevent the characteristics of the varistors from changing with temperature, they are enclosed in an oven that maintains a constant temperature slightly above that usually found in central offices.

The characteristic of the compressor in terms of its input and output voltage is shown in Figure 3, where it is assumed that the amplifier has just sufficient gain to make the output and input voltages the same for signals of maximum value. It will be noticed from this curve that, for low values of input voltage, a variation in the input produces a relatively large change in the output, but that for large values of input, a change in the input produces comparatively little change in the output. At the output of the compressor, therefore, the samples would appear as on line C of Figure 1.

This compressed output is passed to the coding circuit,* which divides the total range into 128 equal steps, and assigns one, and only one, code to all values of the signal falling within the range of one step. Dotted lines have been drawn on Figure 3 to indicate the way the quanta are increased by the compressed characteristic as the signal input is increased. Each step represents eight of the actual system.

At the receiving end of the circuit, the codes are converted by the decoder* to 10.5-microsecond pulses of voltage equal to the values of the quantum represented by the code. As indicated on line D of Figure 1, these are still the compressed values of

*RECORD, November, 1948, page 451.

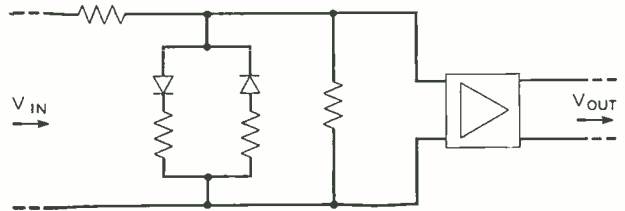

Fig. 2—This simplified schematic shows the essential elements of the compressor. It contains, besides the shunt and series resistors, two varistors oppositely poled and bridged across the circuit

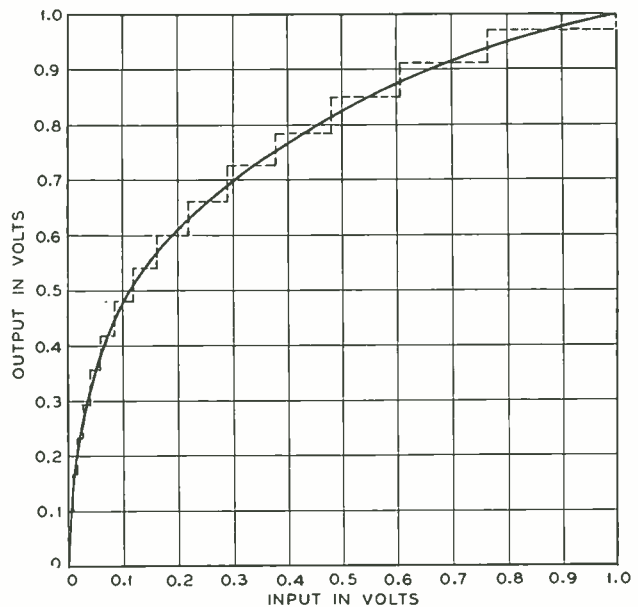

Fig. 3—Compressor characteristics, solid line, in terms of its input and output voltage. The dashed lines show quanta. For low values of input voltage, a variation in the input produces a relatively large change in the output, but for larger values of input, a change in input produces comparatively little change in output

*RECORD, October, 1948, page 411.

the specimens, and they are now passed to the expander to have their original values restored.

The expander circuit is shown in Figure 4. It includes a compressor like that of Figure 2, but here the compressor is connected

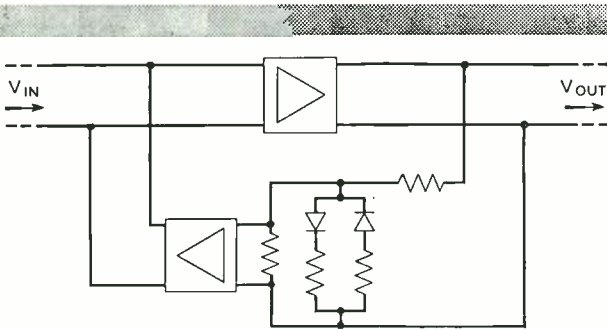

Fig. 4—Simplified schematic of the expander circuit

in the feedback path of an amplifier. As a result, the effect of the loss circuit is just the reverse of that of Figure 2. The relationship of its input and output voltage, in other words, is exactly the same as in Figure 3, but with the two scales interchanged, that is, the output is now the input, and vice versa. As a result, the output, shown on line E of Figure 1, consists of pulses of the same height as those of line B. The decompressed pulses from the expander are then distributed through a group of twelve electronic gates to their respective channels.

In each channel at the output of the receiving distributor are capacitors that store the voltages of the various pulses until the next one is received. When this output is passed through a filter, the resulting output to the channel is the wave shown on line F of Figure 1, which duplicates the original shown on line A.

THE AUTHOR: PAUL A. REILING joined the Laboratories in 1926, and after completing a three-year series of student assistant courses became a Member of the Technical Staff. He then attended the College of the City of New York and received a B.S. degree. Mr. Reiling's work in the Research Department has included studies of feedback amplifiers, varistor modulator circuits, and carrier systems. During the war, his work was concerned with the design of numerous nonlinear-coil pulser networks used in Navy radar systems. At present he is continuing studies of PCM circuits.



"We have all felt over the years the inspiration of 'the message must get through.' Much of the joy of living would be lost if the younger members of our enterprise, who some day will be members of the Telephone Pioneers, fail to recognize the intangible thrill that comes of loyalty, not necessarily to an organization although that means a great deal to those who feel it, but loyalty to an ideal, to a job well done, and particularly to a job well done that means so much to the welfare and happiness of so many. Those, after all, are the things that men live by, they are the kind of things that make life exciting and worth while."

Walter S. Gifford, at the Charter meeting of the Pioneers' Chapter which bears his name—November 5, 1948.

L. A. DORFF
Radio
Transmission
Engineering

HIGHWAY MOBILE RADIO SYSTEMS

Substantial progress has been made in the Bell System during the past two years in establishing mobile telephone service for vehicles. This mobile telephone service, inaugurated in St. Louis¹ on June 17, 1946, is given through two types of systems. Urban² mobile telephone systems serve the metropolitan areas and many of the cities of 100,000 population and over, and highway³

¹RECORD, July, 1946, page 267. ²RECORD, April, 1947, page 137; June, 1947, page 244; September, 1947, page 330; and October, 1947, page 376. ³RECORD, February, 1946, page 62.

mobile telephone systems serve inter-city highways and waterways and cities along these routes which do not have independent urban facilities. These highway systems are rapidly expanding into large area coverage systems blanketing complete states. The urban mobile telephone systems operate on six two-frequency channels in the 152 to 162-megacycle band, while the highway systems have been allocated twelve two-frequency channels in the 30 to 44-megacycle band.

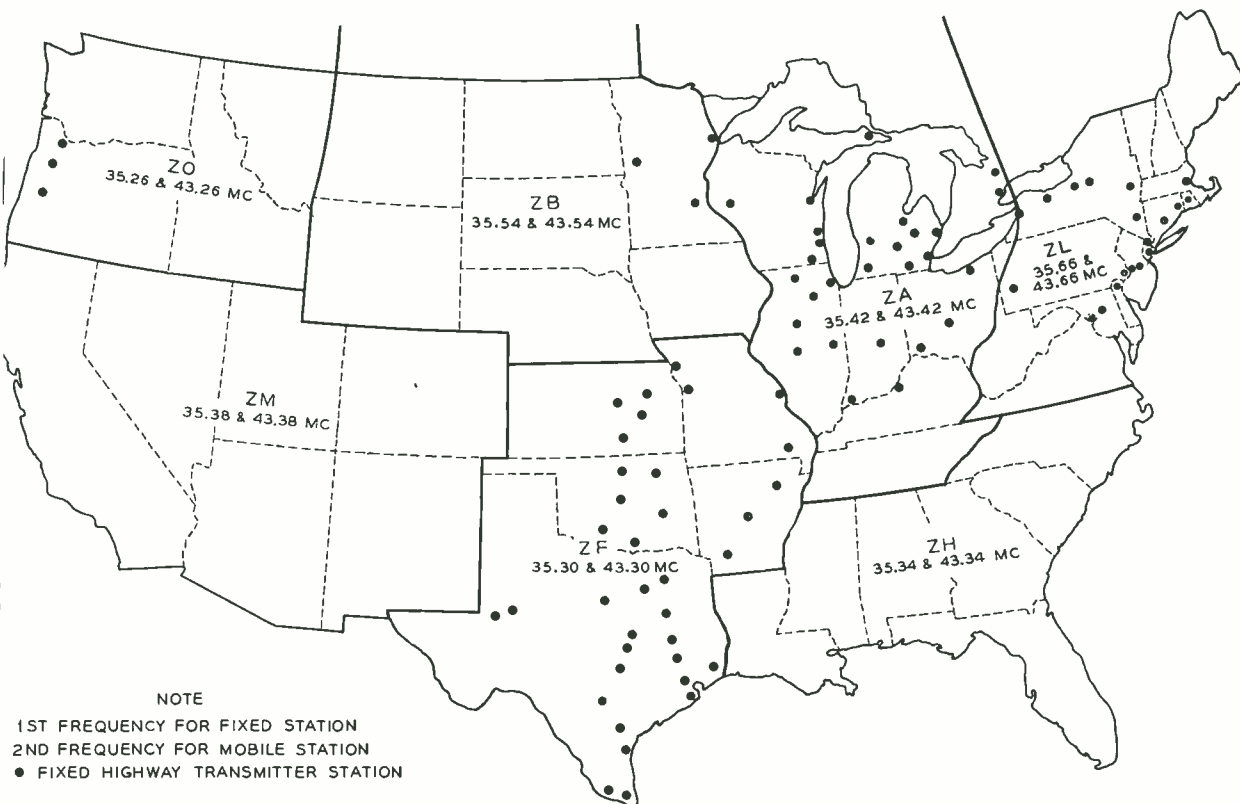

Fig. 1—Land stations and zones for the highway mobile radio-telephone system

As of August 21, 1948, Bell System urban mobile radio-telephone service was available in sixty cities in the United States and Canada, serving a total of about 4,000 mobile units and handling approximately 117,000 calls per month. Highway mobile telephone service in the United States and Canada has expanded to include eighty-five fixed transmitting stations, which are called "land" stations because of their similarity to the land stations for ship-to-shore service, and these serve about 1,900 mobile units and handle approximately 36,000 calls per month. These highway systems already cover such major highways in the East as the New York-Boston, New York-Washington, and the New York-Albany-Buffalo routes. In the Middle West, many of the major highways of Michigan, Illinois, Wisconsin, Kansas, Oklahoma, and Texas are covered, and before the end of this year, these state-wide systems will be expanded and additional systems will be in service in Minnesota, Missouri, and Arkansas. Along U. S. Route 99 in the Pacific Northwest, three stations are now in operation in the State of Oregon. Nine stations are under construction in the State of California. Existing highway service stations are shown in Figure 1.

When highway service was first inaugurated in Green Bay, Wisconsin, August 28, 1946, it was planned to operate all stations throughout the United States on a single channel of two frequencies, one for transmission to the mobile unit and the other for transmission from the mobile unit. This would allow a vehicle equipped with the normal single-channel radio set to travel anywhere and make or receive calls. While testing the first systems, however, considerable sky-wave interference was experienced between systems separated geographically by distances of about 1,000 miles or more. Calculations indicated that this type of interference could be greatly reduced by dividing the country into zones 800 to 1,200 miles in extent and assigning particular channel frequencies exclusively for use in one, and only one, zone. A frequency zoning plan comprising seven zones was adopted and is also shown on Figure 1. With this plan, all stations within a particular zone operate on the same channel fre-

quencies. Vehicles moving from one zone to another may be equipped with an additional oscillator unit with relay-switched crystals, which is controlled by a manual channel selector mounted alongside the unit holding the handset. As the mobile subscriber moves into a different zone, he must manually switch the frequency of his mobile radio equipment. Areas such as Buffalo, located on the zone boundaries, have land stations operating on the channel of each zone. The channel switching equipment available for the mobile unit, shown in Figure 2, is capable of manual switching to as many as six different channels in the highway service band of frequencies. The added oscillator and crystal unit is shown

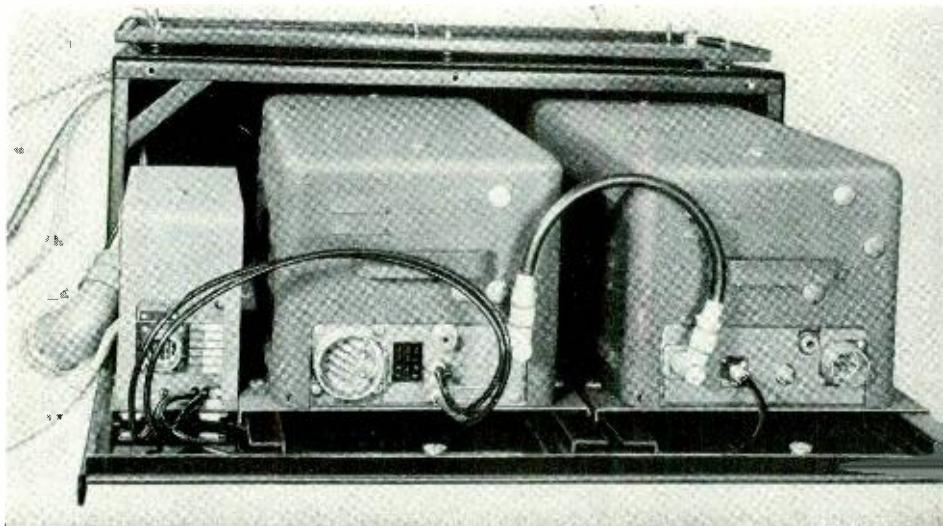

Fig. 2—One of the 46A control units used for frequency selection mounted at the right of the mobile telephone set

at the left of the radio transmitter and receiver in Figure 3.

Although all the equipment, both land station and mobile unit, as well as the method of operation are essentially the same as urban except for the channel frequencies, the provision of highway mobile telephone service presents problems of considerably greater complexity than does urban service. To mention a few of the important differences, there is first the need

Fig. 3—A 26-type oscillator unit at the left of the 239-type radio - telephone equipment



for continuous coverage over the entire length of hundreds and ultimately thousands of miles of highway or thousands of square miles of area, as against coverage of a limited urban or metropolitan area. This, of course, requires many land stations established miles apart along the highway or covering the desired large area. Each of these stations is operated as a separate entity and with a particular point of contact with the wire plant of the Bell System, but each must also function smoothly as a part of the whole system to the end that a mobile unit may travel anywhere in the entire service area and yet be reached promptly and satisfactorily.

In these systems, spacing between land transmitters is an important factor. The transmitters must be sufficiently close together to assure an adequate signal along the entire route or over the entire area in area coverage systems, but far enough apart to avoid excessive overlapping. The fact that for the present, at least, all highway system stations in the same zone must be operated on the same channel or pair of frequencies, while advantageous from some points of view, complicates the problem by creating the possibility of interference to mobile telephone units that are operating between adjacent land stations.

As a result of this overlapping, adjacent

THE AUTHOR: LOUIS A. DORFF received a B.S. degree in Electrical Engineering from the University of Michigan in 1924, and an M.S. degree



in Engineering in 1925. During the preceding two years he had also been an instructor at the University. Joining the D & R of the A T & T in 1925, he worked chiefly on dial system switchboards in the dial equipment group, and continued this work after the consolidation of the D & R with the Laboratories in 1934. In 1941 he transferred to the group concerned with developments and requirements for fixed and mobile air defense communications systems. From 1942 to 1945, while on leave of absence from the Laboratories, Mr. Dorff was Special Consultant to the Air Forces. Upon returning to the Laboratories in 1945, he joined the toll facilities engineering group to work on interconnections for the radio and wire plant. In 1946 he transferred to the radio transmission engineering group for work on mobile radio.

transmitters cannot be operated simultaneously if one of them is being used with a mobile unit in the overlap area. A mobile unit so located will, in general, be able to hear either land transmitter, and when it is in use with one of them, operation of the other may cause interference. At the present time, each mobile service operator in a highway system is given information in the form of busy lamps regarding the status of operation of all land transmitters immediately contiguous to her area, and thus is able to avoid having adjacent land transmitters on the air at the same time, except under emergency conditions.

These highway or large area coverage systems have proven particularly useful to public utilities in assisting them in dispatching crews to repair storm damage in the thinly populated areas. River tow boats save many hours by receiving their orders while under way and by planning for the delivery of supplies and provisions at points where they expect to dock. Large trucking companies are also extensive users, and more recently railroads* are beginning to equip some of their trains with radio-telephone equipment to connect with the mobile system.

*RECORD, January, 1948, page 9.



MAGNETIC FIELD STRENGTH METER

The Hall effect, wherein a potential difference may be produced across a strip of current-carrying conductor by placing the strip in a magnetic field, was employed by G. L. Pearson of the Murray Hill Laboratory to create a simple self-contained magnetic field strength meter.

In the photograph, P. W. Foy is using the instrument to probe the field in a magnetron magnet. The meter is read directly in gauss. Accuracy to ± 2 per cent is obtained at fields between 100 and 8,000 gauss; at higher ranges up to 20,000 gauss, readings may be low up to 8 per cent. Chief advantages for this meter are its portability, the continuous rather than ballistic type of readings and the thin non-magnetic probe, of the semiconductor germanium, that permits search in very narrow gaps.

In a PCM system* of transmission, the speech signals are sampled at regular intervals, and the values of the samples are transmitted as a coded sequence of on-or-off pulses. If the sampling rate is more than twice the highest frequency component in the speech, the original speech wave can be reproduced precisely from such samples; and by transmitting the value of the samples in terms of on-or-off pulses, no noise is picked up over the transmission path. Since the sample may be of any of the infinite number of possible values within the range the system is designed to handle, however, there would have to be an infinite number of codes if every possible value were to be truly represented. This is impossible practically, of course, and so the range of signal values is divided into a number of steps, and a single code is used to represent any value of the signal falling within the range of a single step. This process is called quantizing, and is itself the source of a characteristic kind of noise to be discussed here. In Figure 1, the height of the steps is the "quantum," or the smallest recognized voltage difference. Any input voltage between $-e/2$ and $+e/2$ results in a zero output voltage; any input signal between $+e/2$ and $+3e/2$ is represented by an output voltage of e in value, and so on. The value of the sample as transmitted, therefore, will in general not be quite the true value, but will never depart from it by more than $e/2$.

In designing such a system, it is necessary to determine what the effect will be on

the reproduced signal of this failure to transmit the exact values of the samples. The nature of the result of quantizing is indicated in Figure 2 for two sine waves of different amplitude but the same frequency. The smooth curves represent the waves before quantizing, while the stepped curves indicate the quantized form of wave for the quantum scale shown at the left. For the low amplitude wave, only three

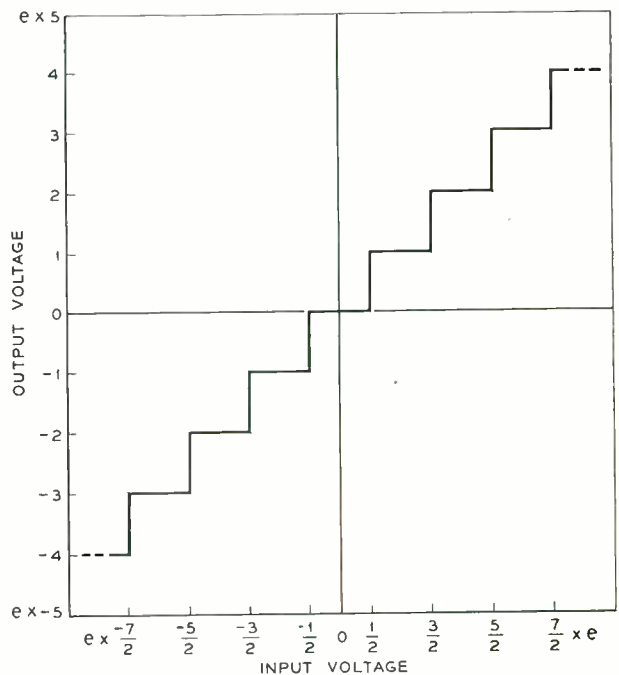

Fig. 1—Staircase characteristic representing quantization

*RECORD, September, 1948, page 364.

quanta are passed over—that spanning the zero axis and one above and one below it. For the higher amplitude wave, however, many quanta are passed over.

As a result of its stepped nature, a quantized sine wave would be represented by Fourier analysis as the sum of a large number of harmonics in addition to a wave having the fundamental frequency of the original wave. These harmonics, since they were not in the original waves, represent a distortion introduced by quantizing. At the receiving end, the wave is passed through a low pass filter, and thus many of the harmonics will be eliminated before reaching the listener, but there will be a residue that will appear as something added to or changed in the original wave.

A simple inspection of Figure 2 will suggest that the amplitudes of the harmonics will be smaller the smaller the size of the quanta, and that their value relative to the signal will be less for large amplitude signals than for small, but only by more com-

plete analysis or by actual listening tests can the effect of this distortion be accurately estimated.

An analysis of the values of the third harmonic of a sixty-four-step quantized sine wave is shown by the solid curves of Figure 3. As the amplitude of the signal increases, the amplitude of the harmonic oscillates, attaining peak values for certain values of the signal and actually disappearing for others. The maximums of the oscillating harmonic amplitude, moreover, are alternately high and low, but at the same time steadily becoming smaller relative to the signal as the signal amplitude increases. These peaks of values all lie on the two dashed lines. Other harmonics behave in a similar way, but their zeros and maximums will fall at different points, and thus at no point will there be a complete absence of harmonics.

Besides these harmonics, there are also cross-products of the sampling and sampled frequencies, and thus the complete effect

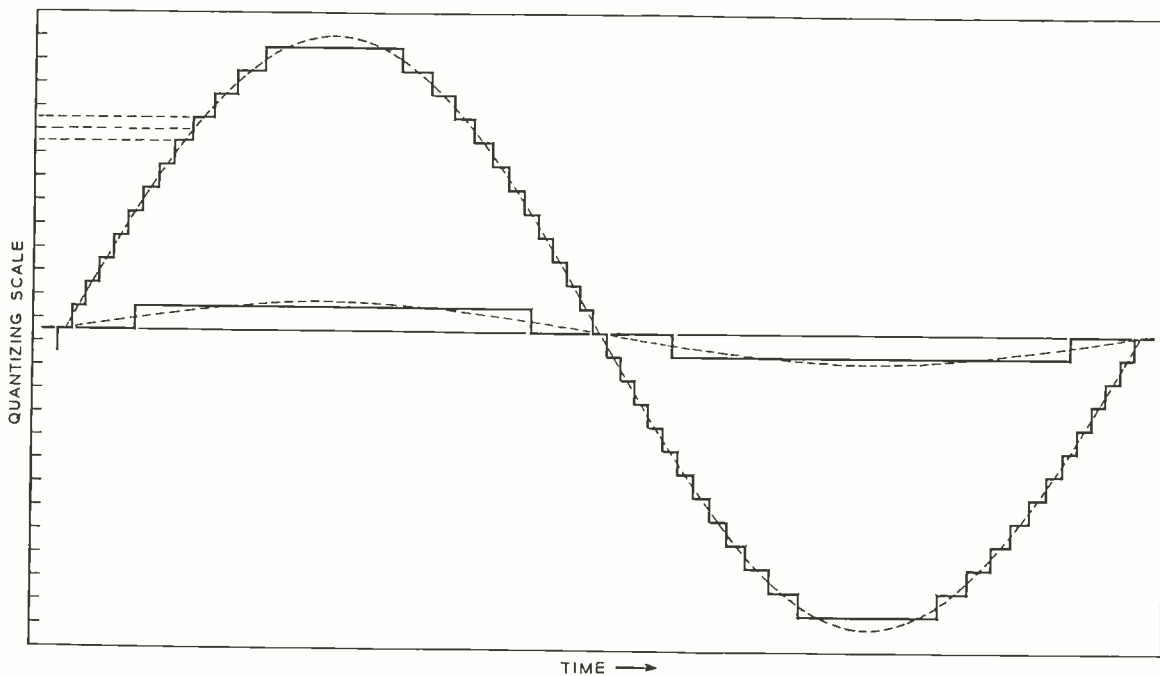

Fig. 2—Comparison of quantized sine waves extending over large and small numbers of steps. The smooth curves represent the waves before quantizing, while the stepped curves indicate the quantized form of wave for the quantum scale shown at the left

of quantizing and sampling is the introduction of a very large number of components, all of which vary with the quantum size and become smaller relative to the signal as the amplitude of the signal increases.

Since the resultant magnitude of the harmonics and cross-products is obviously a function of the size of the quantum, and since the size of the quantum decreases with the number of steps included in the range of the quantizer, an estimate of the distortion may be obtained from the ratio of the maximum signal to the quantum. With N equal quantizing steps, calculation shows that the ratio of full-load signal power to the total power included in the distortion components is expressible in db by the approximate formula $20\log N + 3$. With a six-digit code, there are sixty-four quantum steps, and thus the signal power at full load would be 39 db above the total distortion caused by quantizing. At maximum signal, the dashed lines of Figure 3 show a ratio of signal to third harmonic of

about 55 db; the difference between this value and 39 db is accounted for by the other components that must be considered in addition to the third harmonic.

Based on such an estimate, therefore, the distortion introduced by quantizing when sixty-four equal steps are employed would vary from a value equal to or greater than the signal for very weak speech down to 39 db below the signal at maximum value, and actual tests have shown this to be about correct. In the experimental 96-channel PCM system, the over-all effect of the quantizing noise is made less than the above figure would indicate. Those figures are based on quantizing in equal steps, while in the actual system, the signal is compressed* before the samples are taken, and expanded after the transmitted signals are decoded. As a result, the quanta are not all of the same size but are smaller for low-level speech and larger for high. The quantizing is actually carried out with

*Page 487 of this issue.

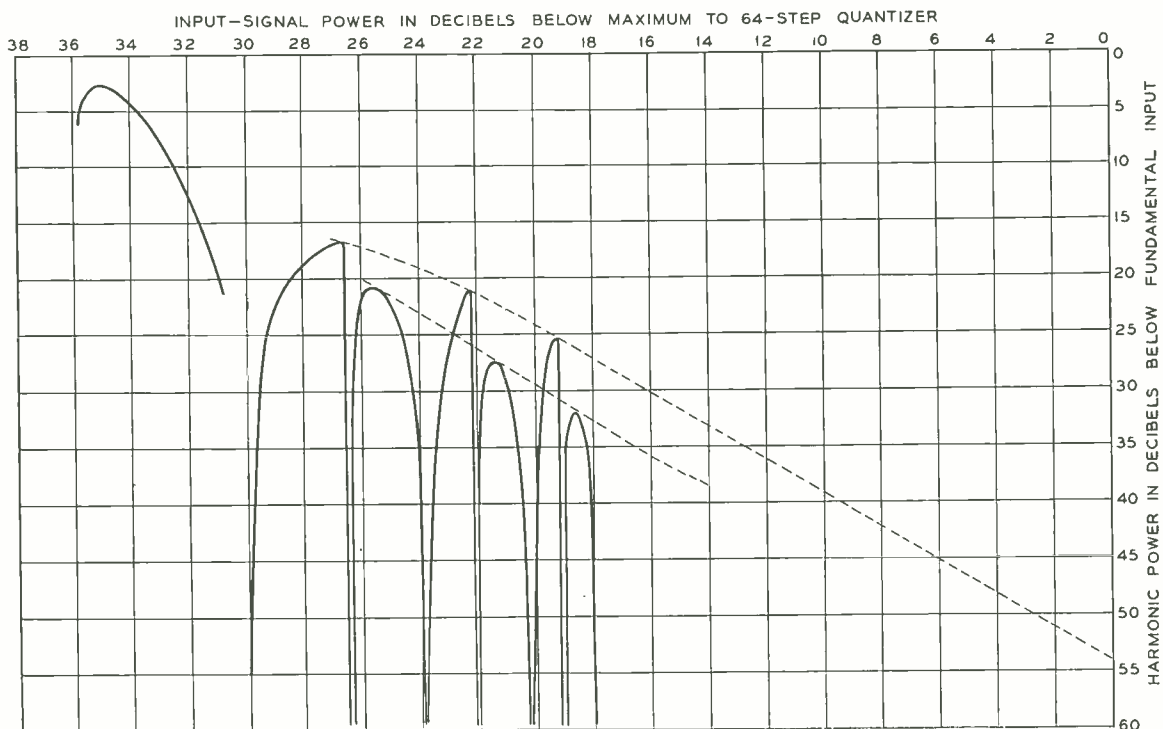

Fig. 3—Variation of third harmonic in quantized sine wave with signal power

equal size steps, but since it is performed on the compressed signal, the steps are not of equal size in terms of the uncompressed signal. Because of the compression, many nearly equal steps are provided for weak speech. Since the noise coming in over the line is comparable with the weaker parts of

Some interesting photographs showing the structure of quantizing noise have been taken by R. R. Riesz using the sound spectrograph.* The noise was isolated for purposes of study by balancing out the original signal in the quantized output. Figure 4 shows a spectrogram in which a speech sig-

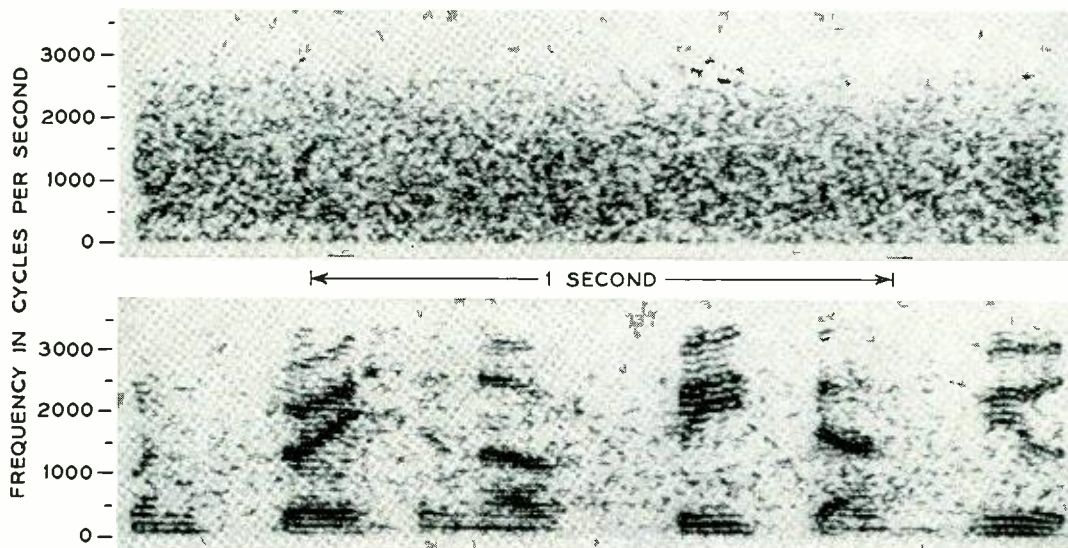

Fig. 4—Spectrograms of sample of speech plus fluctuation noise and corresponding quantizing errors

weak speech, quantizing distortion components generated from the incoming noise persist while the speaker is silent. To the ear, these distortion components sound like a background of steady noise whose power level may be computed from the size of the small steps. In the receiver an expansion takes place to compensate for the compression at the transmitter, and the combination of compressor plus expander is called a "compandor." The effect of companding is to increase the signal-to-noise ratio for weak signals at the expense of a slight reduction when the signal is large. Just how much and what type of companding to use was guided by listening tests and by the type of companding circuits that could most satisfactorily be used. It was found experimentally that a properly designed compandor made satisfactory telephone transmission possible with a seven-digit code (128 steps) while several digits more would be needed with equal steps.

nal from a phonograph was applied to a seven-digit binary PCM system without a compandor. The loudness was adjusted so that peaks in the speech employed a substantial fraction of the 128 equal steps. Thermal noise of an amount comparable with the weak parts of the recorded speech was added so that the situation was similar to the telephonic case of weak speech and its associated line noise applied with compression to give weak speech a larger proportion of the total number of steps. The lower spectrogram shows the signal input to the PCM transmitter, and the upper shows the amplified quantizing noise, i.e., the amplified difference between the original signal and the output wave delivered to the speech channel by the PCM receiver. The horizontal scale represents time and the vertical scale represents frequency. The density of exposure at each point represents the energy per cycle at the frequencies and

*RECORD, January, 1946, page 7.

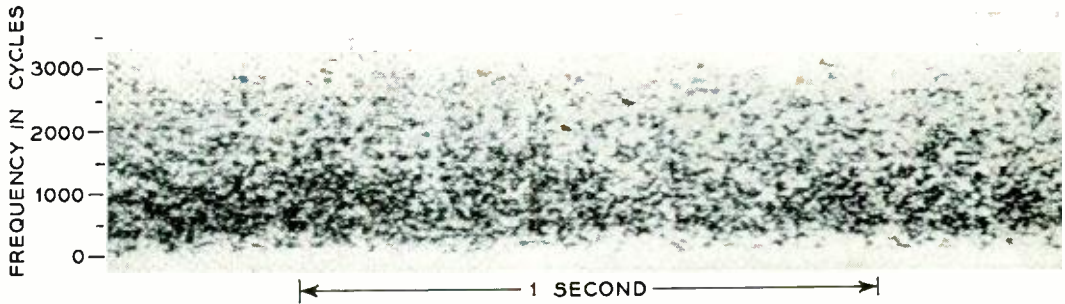

Fig. 5—Spectrogram of fluctuation noise alone

times corresponding to the coordinates of the point. The time scale on the quantizing noise pattern is accurately lined up with the time scale of the corresponding input signal. Inspection of Figure 4 shows no correlation between the quantizing noise pattern and the speech pattern. The quantizing noise pattern is, in fact, indistinguishable from the spectrogram of pure random or thermal noise that is shown in Figure 5.

Thus a PCM system, when used for te-

lephony, possesses a source of noise very much like thermal noise, but for the most part it is not detected by the listener. When a compandor is used, as in the experimental PCM system, this noise is independent of the speech amplitude for weak speech, but its level rises as the speech becomes stronger. Even at the highest speech levels employed, the noise is not of sufficient relative magnitude to disturb the listener since it is masked by the loud speech.

THE AUTHOR: W. R. BENNETT joined the Research Department of the Laboratories in 1925, after obtaining a B.S. degree in Electrical Engineering from Oregon State College. He continued his studies at Columbia University under the part-time post-graduate plan and received an M.A.



degree in Physics in 1928. He has also completed the qualifying requirements for a Ph.D. During the first ten years with the Laboratories, he worked on wire transmission problems—mainly on terminal apparatus in the voice and telegraph range. He made early contributions to the insertion-loss method of network design, and introduced new procedures in the analysis of noise and distortion. In 1935 Mr. Bennett became associated with research on coaxial carrier, and during the next several years helped to establish requirements and measuring techniques applicable to the load rating of multi-channel repeaters. He also conducted experimental and theoretical investigations of time-division multiplex and frequency modulation. Throughout World War II he was associated with secret projects for the Armed Forces. Since then he has been engaged in a study of multiplex techniques for communication at frequencies in the microwave region.

STANDARD CAPACITOR

This story begins with two West Street engineers at lunch in The Inkspot. Said H. T. Wilhelm to T. Slonczewski, "You think you're a mathematician. Compute for me the capacitance between two plates that have a partial shield between them."

(Capacitance, in case you haven't heard, measures the amount of electricity that can be stored between two conducting surfaces, as in a capacitor.)

"What for?" said Mr. S.

"For a standard capacitor of about a tenth micromike," said Mr. W.

(You can associate *one* micromike with the capacitance between a pair of thumb tacks separated by a sheet of letter paper, illustrated in Figure 1.)

"That's a tough one," said Mr. S. "What

will you bet that I can do it or produce a better design?"

"A nickel, even money, just to make it interesting."

"Taken," said Mr. S.

And since J. S. Elliott was the man who needed the capacitor under discussion, he became stakeholder.

Just to post you on what Mr. Slonczewski, Figure 2, was in for, capacitance be-

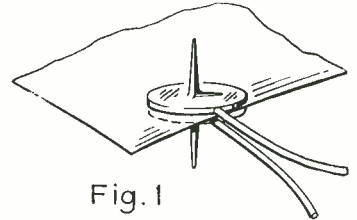

Fig. 2—T. Slonczewski and the capacitor he invented



tween two plates is easily figured if the lines of electric force are parallel as in the middle of Figure 3. Trouble is, they fan out at the edges and those curved lines are hard to calculate. So the usual design is like Figure 4; the circuit is arranged to measure the capacitance between A and B only and ignore the rest. That works fine, as long as A and B are relatively close together for their area. But to get down to less than a micromike, the plates have to be a lot farther apart and the "guard ring" alone won't do the trick. Here was the problem, as Mr. S. saw it:

"I have two circular metal plates about 3 inches in diameter and a half inch apart—that's what the simple formula for capacitance requires for one micromike. But the formula is accurate only when the lines of force are straight and parallel, clear out to the edge. How to get them straight and parallel?"

“Well, a line of force is like a stretched rubber band—let it alone between two fixed points and it’s straight. I’ll make sure the outer lines of force are well ‘let alone’ by shielding them with a surface whose potential is the same at each point as that of the

wire as the shield; its lower end is connected to the lower plate of the capacitor; the guard circuit keeps the upper end at the same potential as the upper plate of the capacitor, as shown in Figure 6. And, of course, the resistance drop along the wire

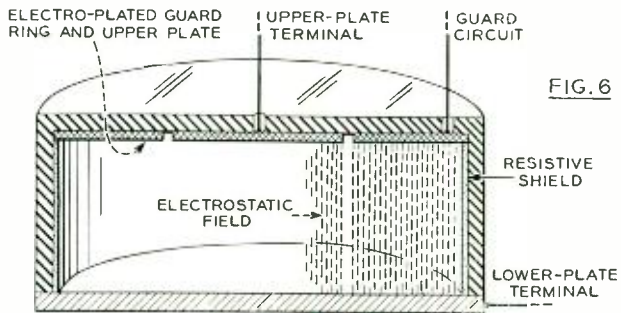
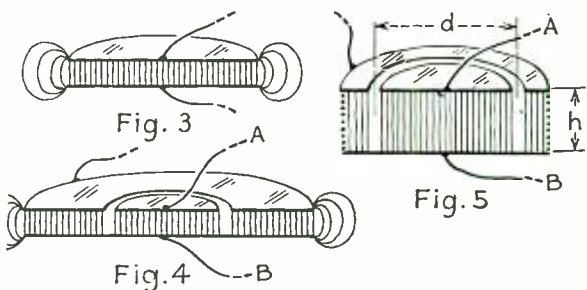

nearest point on a line of force, Figure 5. That way, there will be nothing to pull the lines of force, so they will stay straight and parallel and I can use the simple formula.”

With that, Mr. S. was over the hump. He specified a single-layer coil of fine resistance

brings its potential down at exactly the same rate as the potential falls along the lines of force. When the shop made up a model, from details worked out by Mr. Elliott, its measured value came out exactly to its calculated value.

The Laboratories test plot at Gulfport, Miss., contains specimens that range in size from small saplings and 3/4-inch square stakes 18 inches long, to full-size poles. Periodic inspection results are correlated with those of the Leutritz soil block test. Interpretations are used as guides for the inspection of poles in the telephone plant—Photo by G. Q. Lumsden

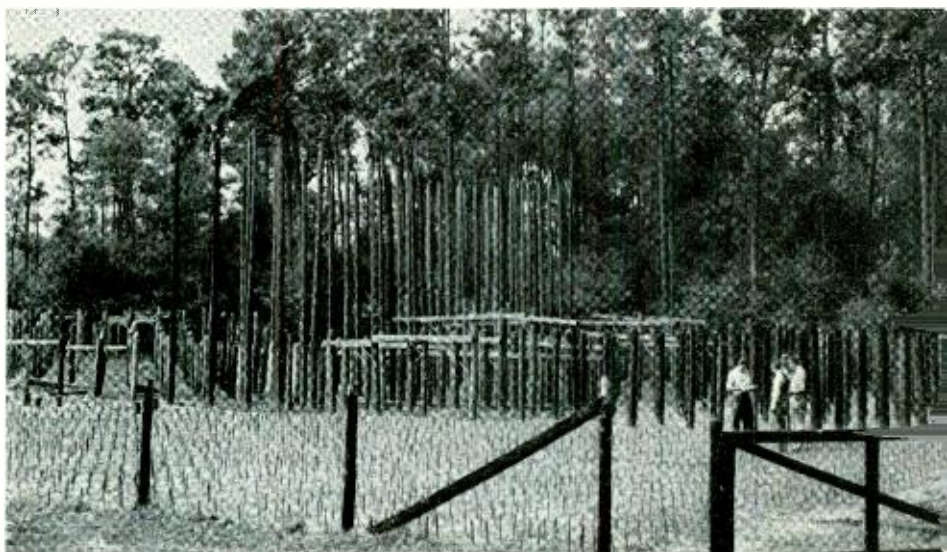

ELECTRONICS AT ALLENTOWN

To provide modern housing for its growing electronics manufacturing, the Western Electric Company has just completed a new plant on the outskirts of Allentown, Pennsylvania. That city was chosen for its adequate supply of power and water, suitable atmosphere, good living conditions for the 2,500 employees and proximity to the Laboratories and Western Electric plants. Construction was started in March, 1946, on a 50-acre hilltop site with magnificent views in all directions. Route U. S. 22 borders the property, which is eighty miles from the Murray Hill Laboratories. Of the two major buildings, one houses the offices, the other the plant and laboratory operations. These and several small service buildings are of light-colored brick.

acoustical ceiling covers the entire main floor with the space above the ceiling being used as a plenum chamber for return air. The main manufacturing floor is of laminated construction consisting of 3 by 6-inch timbers laid on edge and covered with strip maple flooring. The building itself performs a proportionate rôle in keeping the indoor atmosphere under control. For example, the exterior walls consist of a layer of face brick backed by four inches of common brick, one inch of rigid inorganic insulation and vapor seal plus an inside lining of 4-inch glazed tile. Except for doorways, the interior is completely sealed off. It takes 12 hours for solar heat to penetrate the walls and four hours to penetrate the roof. A "vision strip" of Thermopane girds the building.

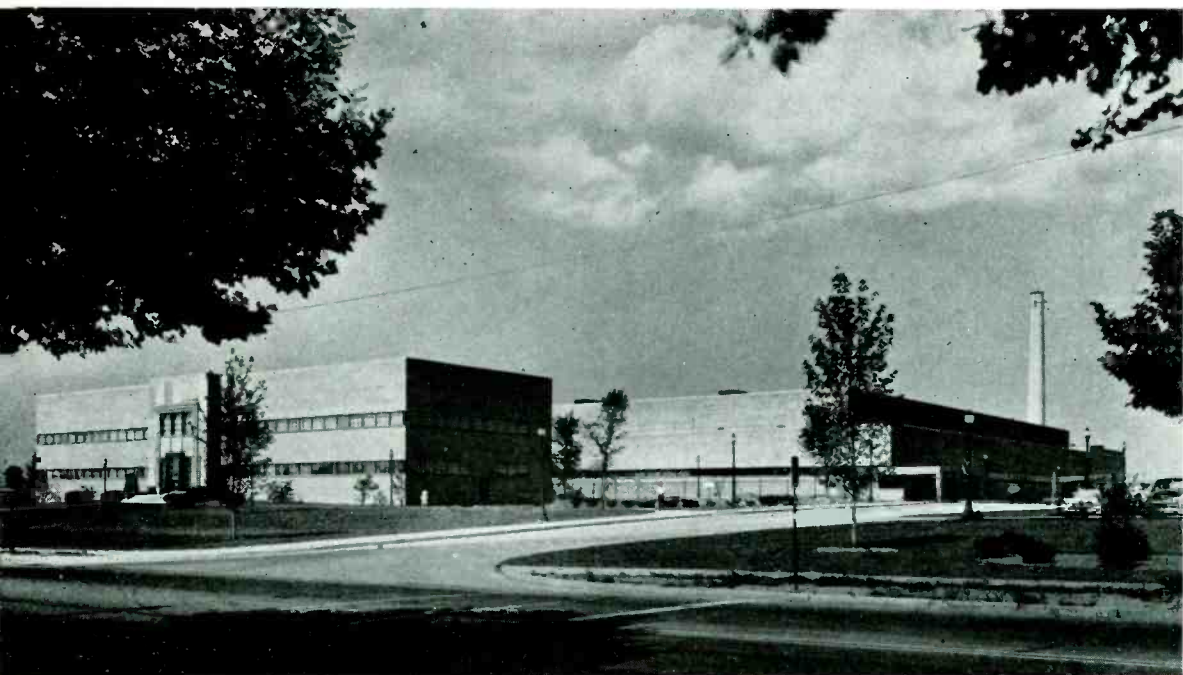

The main manufacturing building, which will house some 5,000 machines, is a two-story steel frame structure 450 feet long and 375 feet wide. All service piping, duct work and conduit is systematically arranged and suspended under the ceiling of the lower floor so that no drop piping is required from the main floor ceiling to distribute the hydrogen, nitrogen, oxygen, illuminating gas, water, compressed air and other services to the operating machines. Over 13,400 forty-watt fluorescent tubes supply the proper illumination required for the precision manufacturing operations. An

The air-conditioning system maintains any temperature between 70 and 80 degrees F. at plus or minus two degrees and a relative humidity between 40 and 55 per cent throughout the year. The system processes some three-quarters of a million cubic feet of air per minute and maintains an indoor pressure that is slightly greater than the pressure on the outside.

Directly in front of the manufacturing building and connected by corridors is the office building. It houses the main entrance, and such administrative activities as engineering,



On the main floor, these Western Electric girls are assembling miniature and repeater tubes

accounting, personnel, and public relations. It is completely air conditioned and the ceilings are acoustically treated.

While varistors, thermistors and copper-oxide rectifiers are made at Allentown, Bell System demand for vacuum tubes is so heavy that it will require most of the capacity of this new plant. Western Electric's electronics work will be concentrated here, and the Electronics Shop at 405 Hudson Street has been closed.

Quarters of the laboratory occupy about 10,000 square feet of floor space, all air conditioned and lighted by fluorescent tubes. In addition to offices and files, there is a small machine shop, a mechanics' laboratory, a room where tubes are assembled, a glass-working room equipped with heat-treating and sealing-

in machines, a pumping room, and an electrical laboratory with a shielded room for testing. A telephone tie line connects with Murray Hill.

The Laboratories representation at Allentown is headed by V. L. Ronci. It includes thirty Laboratories engineers and a number of Western Electric people assigned to assist the engineers. Their job is to take the functional designs of the electronic development engineers at the Laboratories and convert them into designs-for-manufacture. In this work they have regard not only for the recommended electrical characteristics of the tube, but also for the machines and techniques which are available to them in the Allentown Plant. It is obvious that, in this highly technical field, manufacturing problems can be appreciated



←V. L. Ronci (center), Allentown Laboratory director, with J. W. West, general engineering; E. G. Shower, large tubes; and S. O. Ekstrand, small tubes. Absent were L. F. Moose, ultra high-frequency tubes; and R. L. Vance, gas tubes

Paul Menzel fusing glass to metal by radio frequency induction heating →

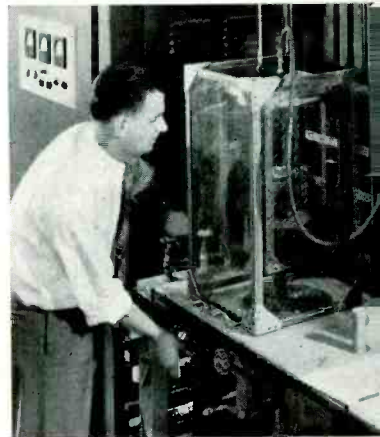

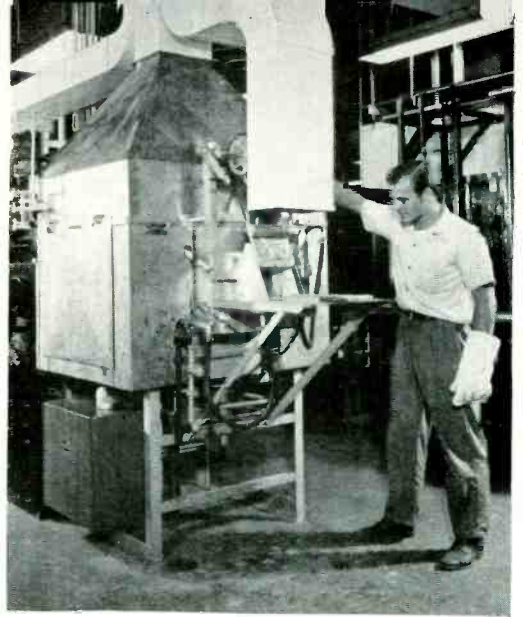
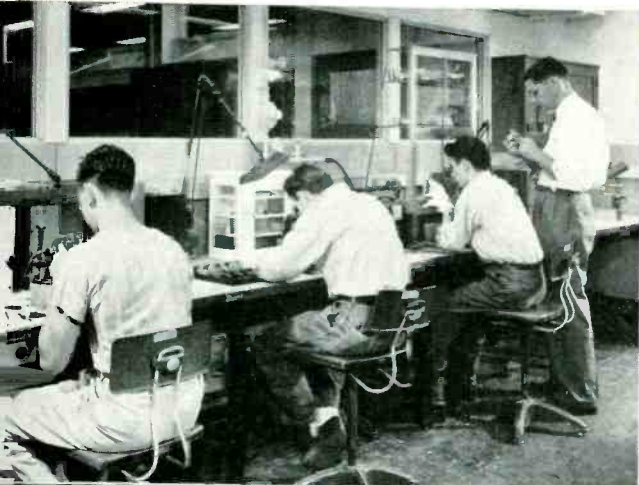

Allentown Views

Above—In this oven, metallic and ceramic parts of various types are heat treated in a controlled atmosphere

Above, left—Assembling small vacuum tubes in the Laboratories' area. Charles Maggs is at the extreme right

Center—Carl Johnson adjusts one of the four glass-working machines. In the extreme rear is an automatic machine for developing button-type stems

Below, left—The applied mechanics laboratory, where shock and vibration tests are made. At left is F. W. Stubner, and on the right is George Dixon

Below—Beyond the glass-working machines is an endless belt oven for developing glass annealing schedules

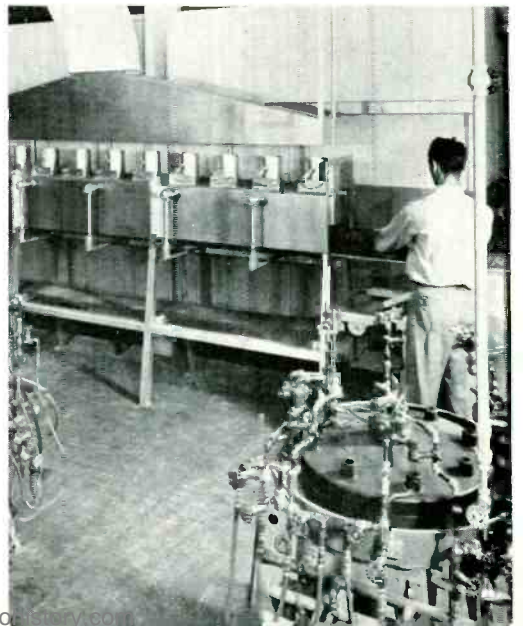
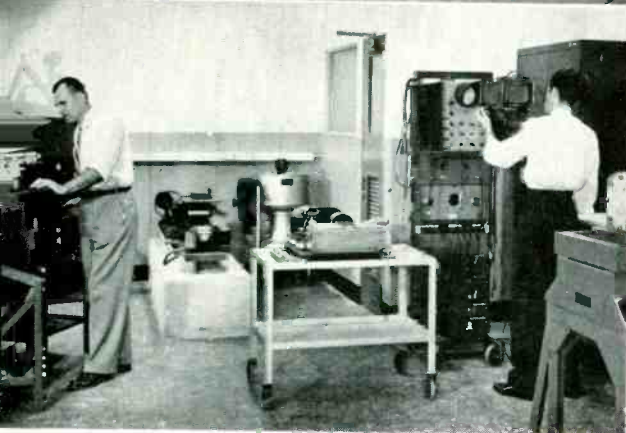
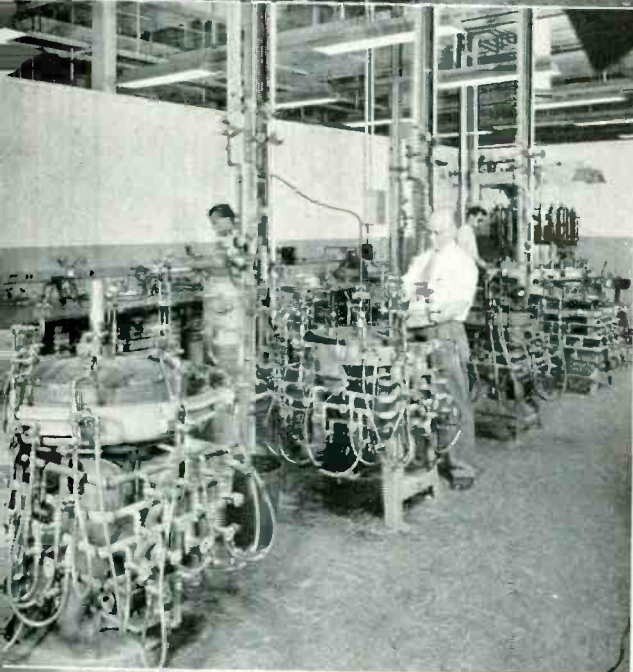

better by locating these engineers in the plant where their designs are manufactured. To put the matter in other terms, the Allentown laboratory will be kept in touch by the Laboratories with the rapidly advancing science and will keep the Laboratories advised of the practicalities as developed by Western Electric's manufacturing engineers.

Reporting to Mr. Ronci are five groups. S. O. Ekstrand has charge of all "small" tubes—repeater tubes, miniature tubes, and general-purpose tubes. L. F. Moose heads a group on ultra high-frequency tubes such as magnetrons and klystrons. E. G. Shower's area includes power tubes; in contrast, he has also been assigned the smallest electronic device, the Transistor. R. L. Vance has gas-filled tubes of both the hot and the cold-cathode type, and ballast lamps. J. W. West is in charge of general engineering, including specifications, technical information, glass development and applied mechanics.

New Automatic Teletype System for Pan American Airways

A private communications network, incorporating new developments in teletypewriter switching apparatus, was placed in service recently for Pan American Airways, Inc., by the Long Lines Department of the A T & T. The new system, which is entirely automatic, is used to relay messages concerning reservations, operations and other business matters between some 56 offices throughout the Nation.

This is the first of several installations to be made for large firms in the near future. Designed primarily for large private networks, this system can handle, automatically, a greater volume of messages with more speed and efficiency than any previous system. Once addressed, a message speeds through switching centers to its destination without any aid by human hands; the switching equipment automatically selects and relays messages along the proper circuits.

Three switching, or "nerve," centers at New York, Miami and San Francisco serve Pan American's Atlantic, Latin American and Pacific-Alaskan divisions. Radiating from each of these centers is a web of lines to airfields and offices in the area it serves. New York is linked with both the Miami and San Francisco switching centers by direct lines. Connected to the New York center are approximately 21 outlying offices. Miami serves 23 Pan American offices, and San Francisco 12 offices.

Messages to be transmitted through the new switching system are typed on a teletypewriter which transcribes the message on a tape. The

tape is placed in a transmitter, which then sends the message. Coded characters at the beginning of each message control the switching equipment, which selects the proper circuits and stations. Another code at the end frees the circuits for another message.

At the switching centers, messages are automatically sent to outgoing circuits and the proper addresses in a continuous stream. Control boards at each switching center permit observation and control of traffic.

Other features of the teletypewriter system include a multiple address arrangement, whereby a message originating at any station can be sent to two or more addresses simultaneously, and teletypewriter facilities which permit Pan American to transmit material requisitions in a



"Nerve" center at New York for Pan American Airways' new teletypewriter system. Direct lines connect this center with similar centers at Miami and San Francisco

few seconds by teletypewriter that formerly took as much as five days by mail.

The Long Lines Department began planning the new automatic teletypewriter network in 1946 at the request of Pan American Airways. The system was designed by the telegraph group of the Laboratories headed by E. F. Watson; a number of pictures of the over-all laboratory tests appeared in the RECORD for September, 1948. Equipment was manufactured by the Western Electric Company and the Teletype Corporation. A training course for some 300 Pan American employees, who operate this system 24 hours a day, was conducted by specially trained Bell System instructors.



TELEPHONE PIONEERS OF AMERICA

Frank B. Jewett Chapter

The annual fall dinner party of the Frank B. Jewett Chapter of the Telephone Pioneers of America, held in the Hotel Commodore on November 12, was attended by about 350 members and guests, including 72 life members. Following an informal reception and dinner, R. A. Haislip, President of the Chapter welcomed those attending and then introduced the program of entertainment, which included a musical skit presented by a Broadway cast.



Arrangements for the dinner and entertainment were made by a Pioneers' committee under the chairmanship of D. R. McCormack. During the reception, there were demonstrations of the Transistor overseas telephone service, and a simplified hearing test device. The exhibits used were laboratory models and displays now being built for science and industry museums.



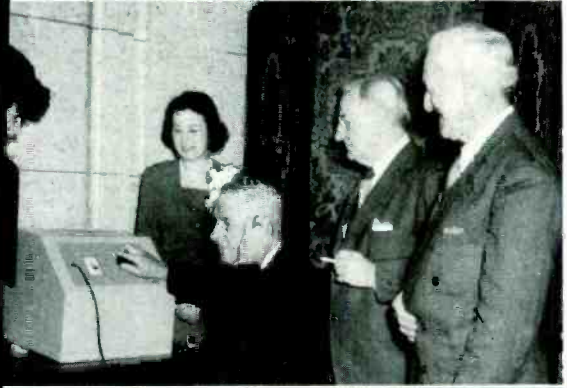

PHILADELPHIA-CLEVELAND COAXIAL OPENED FOR TELEPHONE SERVICE

A long distance coaxial telephone cable between the East and the Mid-West has recently been opened for long distance telephone service. The 460-mile cable extends from Philadelphia, through Pittsburgh, to Cleveland, and adds many long distance telephone circuits along this route.

In the early part of January, 1949, this new cable will also furnish the channels which will connect Bell System east coast intercity television facilities with its recently opened Mid-West intercity television links.

The additional equipment that will be required to adapt the new coaxial cable for the transmission of television programs is still being installed. Bell System engineers will

ment of the American Telephone and Telegraph Company.

To minimize the chances for damage, this coaxial cable was placed underground, where it is secure from storms, fires, falling tree limbs, stray shots from hunters' rifles and other common menaces of aerial lines. About two-thirds of the new cable was plowed directly into the ground and the remaining third was placed in conduits. Steel-armored coaxial submarine cable was used in crossing the larger streams and rivers encountered.

Cable placement began on the Philadelphia-Harrisburg section in October, 1947, and on the Pittsburgh-Cleveland section in February, 1948. Similar work was started in March of

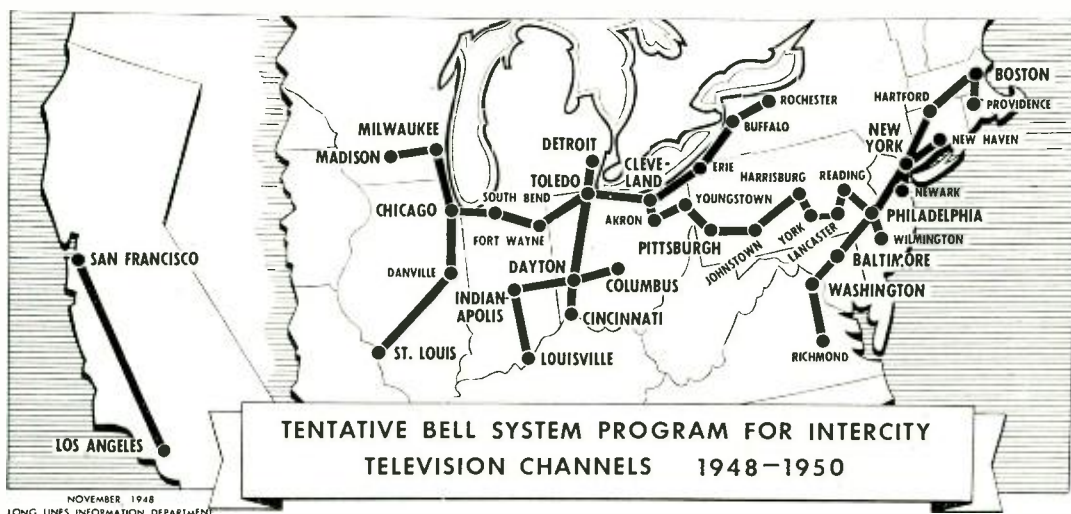

The coaxial cable between Philadelphia and Cleveland is now opened for telephone service and will be ready for television early in 1949

test television transmission and reception for each segment of the new cable, using special testing methods to assure accuracy of reproduction, before the cable will be opened for commercial television service. A single television program can then be broadcast by television stations along the route between the Atlantic coast and the Mississippi River.

The new cable, together with its initial line and terminal equipment, was constructed at an estimated cost of \$12,500,000. The project is a joint undertaking of The Bell Telephone Company of Pennsylvania, The Ohio Bell Telephone Company and the Long Lines Depart-

ment of the American Telephone and Telegraph Company.

Bell System construction crews and engineers tackled one of their most difficult jobs. They had to cross seven mountain ranges between Harrisburg and Pittsburgh. With some of the Nation's richest coal fields located in the Pittsburgh area, they had to find a route for the cable that avoided strip mines and potential coal beds.

The coaxial cable contains eight coaxial tubes, a pair of which, when fully equipped, is capable of handling about 600 simultaneous telephone conversations—or two television programs. Amplification is provided by equip-

ment in small repeater buildings, which are constructed at regular intervals along the coaxial cable's pathway.

Western Electric Tubes Being Made by Machlett Laboratories

F. R. Lack, vice-president of the Western Electric Company, Radio Division, has announced that Machlett Laboratories, Incorporated, has begun the manufacture of Western Electric's long established line of high-power electron tubes for broadcast transmitters and allied applications.

Machlett is manufacturing these tubes for Western Electric to Bell Telephone Laboratories' designs, with full use of the production techniques developed by Western Electric. Rapid installation of additional manufacturing

facilities in the Machlett plant in Springdale, Conn., allowed production to begin during the fall of this year.

Long active in X-ray tube and industrial heating tube production, Machlett Laboratories has made numerous pioneering contributions in design and manufacturing methods. In the 1890's, the firm made one of the first, if not the very first, X-ray tube for commercial distribution in this country and today is one of the world's largest producers of X-ray tubes. The techniques required for manufacturing high-power broadcasting tubes are similar to those used in making X-ray and industrial heating tubes.

With the new arrangement, Machlett will make the entire line of Western Electric high-power broadcasting and industrial tubes.

STRONG TELEPHONE COMPANIES ESSENTIAL

From "Telecommunications Digest," October 20, 1948.

That it is essential to the national economic welfare and defense security that telephone companies provide adequate and expanded facilities and service to the public was forcefully struck home in probably the most important addresses at the U. S. Independent Telephone Association convention by two outstanding state commission leaders—veteran Virginia Commissioner H. Lester Hooker and Chairman Harry M. Miller of the Ohio Public Utilities Commission.

The convention, held in Chicago, Oct. 11-13, was attended by more than 1,800 representatives of independent telephone companies from all parts of the country.

To perform their responsibilities to the public, it is of paramount importance to have the financial soundness and strength of the telephone companies maintained, and it is the duty of the state commissioners to see that telephone rates are compensatory and yield fair rates of return, both state commissioners stressed.

Judge Hooker brought out that not only is telephone service now "an indispensable part" of the national life, but it has also been greatly improved in the past few years. The value of telephone service to the subscriber is far greater than ever before, he added.

The veteran member of the Virginia commission, who formerly headed the National Association of Railroad and Utilities Commissioners, the organization of all state and Federal regulatory bodies, "laid it on the line" that state commissions in this period of inflation

must approach the regulation of rates in a highly constructive manner. He said it is very harmful to the national and public welfare to indulge in political expedients and maneuvering in regulation of the revenues and rates of telephone companies and other utilities.

Judge Hooker warned that the telephone companies cannot fulfill their present-day responsibilities of furnishing expanded and improved service demanded by the public unless they can attract sufficient investor capital, and investors will not be attracted unless their earnings are adequate. In discussing the future financial outlook, Judge Hooker stressed that more equity capital (common stock) must be obtained to avoid the dangers of too heavy fixed debt loads for the telephone companies.

Ohio Chairman Miller likewise emphasized that a fair return "is just compensation for service rendered in terms of the value of money at the time the service is rendered." He stated that with today's demands upon the telephone industry by the public and the need for adequate revenues yielding a reasonable return, regulatory commissions must consider rate increases in a courageous, intelligent and constructive spirit.

State commissions "cannot indulge in a 'sparring match' without doing violence to the public interest and our way of life," he declared. Chairman Miller warned that if the plight of the telephone companies is not adjusted constructively by the state commissions, it might result in Government ownership.

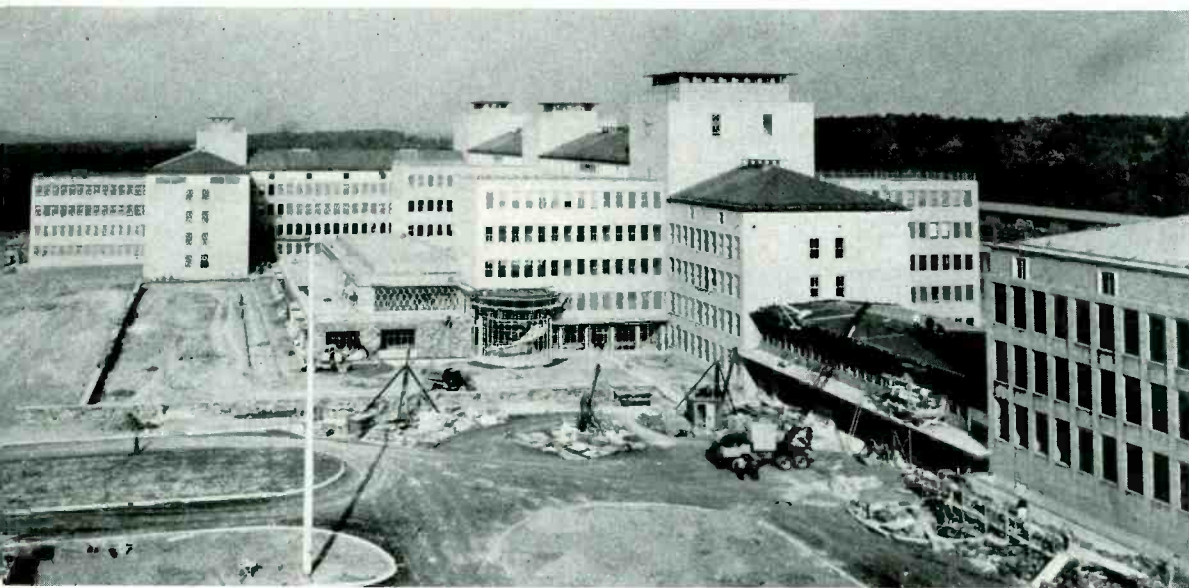

MURRAY HILL NO. 2

Murray Hill's new building group nearing completion is shown in the accompanying illustration. The dual road seen at the left side is from Mountain Avenue. A terminal for public buses is below the bridge which connects the two main buildings at the right. The lower central structure is the new restaurant. Near the center of the photograph is a glass enclosure around a circular stairway between first and second floor restaurant lounge areas. The photograph was taken from a point near the main entrance to the buildings.

The occupancy of Building No. 2 has gained steadily month by month as the contractor's force yields space to Laboratories' personnel. The television research group was moved early in September to the top floor and the mathematical group, later in the same month, to the office wing on the fourth floor near the bridge on the south side. Locations of physical electronics and solid state physics groups were changed during the month of October from Building No. 1 to the easterly end of the second and third floors.

It is planned to start the move of the Transmission Apparatus Development Department in November, extending it through December into January. Upon completion of this latter shift, it is expected to start with the Electronics Apparatus Development Department to be followed as quickly as space is available by the Transmission Development Department. It also is expected that the Model Shop and specified research groups will be moved into the Specialties Building early in 1949. Personnel

and the Library will be moved during the early part of 1949, and other staff groups including Shipping, Receiving and Mail Departments will be moved as their services are required.

Bell System Ready to Furnish 15-Kc Program Networks

Because of the increasing interest of both FM and AM radio broadcasters in 15,000-cycle program transmission, the Bell System Companies are prepared to furnish such service along broadband carrier routes as requested. This service employs special terminals designed for use alternately for either transmitting or receiving. With these terminals, a frequency band wide enough to provide twelve telephone circuits is required for each 15,000-cycle program circuit.

Fifteen-thousand-cycle transmission, which can be used by both FM and AM broadcasters, permits a higher grade of reception for the radio listener with a suitable receiver than the narrower frequency ranges do.

Murray Hill Chorus Schedules

The Murray Hill Chorus accepted the invitation to entertain at the annual Christmas party of the Metropolitan Motion Picture Club at the Hotel Pennsylvania on December 16. On December 19, they will render a program of Christmas music at the Veterans' Hospital at Lyons, New Jersey. Traditionally, the Chorus will give the annual Christmas noon-hour program in the Arnold Auditorium.

Housing Information Center Opens

In the interest of affording more comprehensive information on housing accommodations, in or near the Murray Hill area, which are available to those employees who have been notified of the prospective change of their work location from New York to the Murray Hill laboratory, the Employees' Relocation Service of the Personnel Department has established, in Room 370 at West Street, a Housing Information Center.

The Center contains a complete and up-to-date display of housing possibilities, many with pictures, and all with descriptions of the properties and the prices being asked currently. There are also on display maps of localities in, or adjacent to, the area with information to streets and railroad and bus transportation lines to Murray Hill. Brochures containing descriptions, with floor plans, of houses as furnished by reputable builders and contractors for construction on order are likewise available for reference. The service is not for home buyers exclusively. Information as to furnished rooms and a limited number of rentals, principally in garden apartment developments, is also obtainable at the Center. Employees who are planning home relocation in connection with their scheduled work relocation to Murray Hill may arrange through the Center for personal inspection of any accommodations listed as available. K. M. Weeks became Director of Employees' Relocation Service on December 1, succeeding A. J. Daly, who, having completed his temporary assignment as Director, has resumed his duties as Chief Accountant.

N. J. Press Association Visits Murray Hill

Members of the New Jersey Press Association, accompanied by public relations people of the New Jersey Bell Telephone Company, were guests of the Laboratories at Murray Hill



Marie Vitelli points out a Murray Hill location to D. W. Boale, standing with her. Kenneth Dale, seated, left, is acquainting himself with a real estate brochure, and R. A. Mitchell, right, looks over a house which is for sale in a neighboring community to Murray Hill

on October 29. After a luncheon in the foyer of the Arnold Auditorium, at which R. K. Honaman told of the place of the Laboratories in the Bell System, the visitors were shown some of the laboratories: Outside Plant, by R. J. Nossaman; Telephone Instruments, by W. H. Martin and A. F. Bennett; Crystals, by R. M. Burns; Wood Preservation, by J. Leutritz; Metallurgy, by D. H. Wenny. After a visit to the soundproof room in the Acoustics building, the group assembled in the auditorium for a talk by W. E. Kock on the Transistor. Following a question period, the party was entertained at a buffet supper at Hotel Suburban by the Telephone Company.

New Jersey newsmen at Murray Hill, with a few of the Laboratories' people



Legion Post Installs Officers

New officers of Bell Telephone Post 497, American Legion, were installed at a dinner held on October 26 at the Cornish Arms Hotel. Ten past commanders were included in the forty members and guests who attended.

New York County Post Commander Edward J. Clark installed the following officers: L. A. Dolan, Jr., Commander, WE; W. J. Hogan, First Vice-Commander, WE; L. T. Miller, Second Vice-Commander, BTL; E. N. Emmons, Third Vice-Commander, WE; W. V. Pfandke, Adjutant, WE; G. J. McArdle, Assistant Adjutant, BTL; C. H. Dalm, Finance Officer, BTL; H. S. Hopkins, Service Officer, BTL; W. J. Clark, Chaplain, WE; and J. A. Ceonzo, Sergeant-at-Arms, BTL.

The installation was followed by J. C. Cruger, WE, presenting the Past Commander's badge to H. Bongard, the retiring Commander. Past Commander W. A. Bollinger, BTL, installed the new post standard, and G. Dobson, BTL, gave a report on the National American Legion Convention held in Miami.

New York Telephone Company Asks for Rate Increase

The New York Telephone Company recently asked the Public Service Commission to authorize an increase in its revenues amounting to about 15 per cent of its annual income from its services within New York State. This is the first time in 18 years that the company has requested higher rates for telephone service. A continuous decline in earnings on the money invested in the business started in 1947, and the third quarter of 1948 shows earnings of only 4.15 per cent. Preliminary estimates for 1949 indicate that this trend will continue and that earnings in the future will be at a dangerously low level.

Since 1940, total operating expenses, including taxes and wages, have risen 96 per cent, outstripping the 80 per cent increase in gross revenue. During this period, salary and wage expenses, which constitute the largest single element of cost in furnishing telephone service, have increased 129 per cent to about \$185,000,000. Yet the present force of 70,000 employees is only about 80 per cent greater than it was in 1940.

The company asked approval of a metropolitan service plan for New York City, most of Nassau County and for southern Westchester. In sheer scope, this plan surpasses any in operation elsewhere. It contains the following five advantages for customers:

1. Enlarged toll-free calling areas in the



suburbs and in the adjacent city sections.

2. Choice of message-rate residence service in these suburbs.

3. Faster service through the eventual establishment of direct dialing by customers.

4. Extension of the monthly message-unit allowance to cover calls throughout the enlarged metropolitan telephone area. Also charges for calls between some points in the metropolitan telephone area would be somewhat less than they are under the present basis.

5. Keeping the rate increase down through reducing operating costs, by permitting simplified billing and eventual direct dialing.

A major engineering job, the plan calls for extensive changes and additions involving every central office in the area. Several years' planning and engineering have already gone into it, as well as some preliminary installation.

The rate increases: New York City—Message-rate residence service, up 75 cents for individual lines, 50 cents for party lines. Flat-rate residence service, where it exists in Staten Island and Queens, up \$1 for an individual line, 75 cents for a party line. Business message-rate service, up \$1.50. (All business telephones in the area would be message-rate.)

Increases in Southern Westchester and Nassau County—Flat-rate residence service, up between 50 cents and \$1.50 in most cases, for a greatly enlarged calling area. Suburban message-rate service would cost \$4.25 for residence service (66 message-units) and \$6.25 for business (75 units). Rates are quoted exclusive of tax.

The company's petition also lists 5-cent increases for most basic toll rates for calls within the state where present rates are 20 cents or more and other increases for night, Sunday

and person-to-person calls, for overtime, and for extension stations as well as for switchboards and other equipment.

"Service improvements are being made possible through the company's largest program of expansion in its history," President Whitmore stated. "It has been necessary to construct many new buildings, install and expand hundreds of our central offices and place thousands of miles of cable in the face of today's high prices. This vast undertaking has already called for construction, in the last three years, totaling \$440,000,000.

"Because of continually rising costs," he added, "it becomes increasingly more expensive to build the plant equipment needed for each new telephone. Within the next two years we must obtain another \$200,000,000 from in-

vestors, who will be attracted only if our earnings continue to provide a reasonable return, which they cannot do under present rates.

"Telephone rates must therefore be made adequate if we are to continue providing good service today and building for even better service tomorrow."

Changes in Organization

Following the retirement of F. L. Hunt of the Publication Department, noted in the RECORD for November, H. B. Ely has been appointed Publication Manager—New Jersey Operations, reporting to R. K. Honaman.

W. B. Vollmer has been appointed Shops Manager—New York, reporting to H. C. Atkinson. Mr. Vollmer succeeds A. H. Sass, who retired on November 30.



Top—1948 Legion Installation—H. Bongard, extreme right, swears in 1948 Legion officers shown left to right: W. J. Clark, Chaplain; W. J. Hogan, Vice-Commander; W. V. Pfandke, Adjutant; E. N. Emmons, Third Vice-Commander; J. A. Ceonzo, Sergeant-at-Arms; L. A. Dolan, Commander; C. H. Dalm, Finance Officer (in back of Mr. Dolan); and L. T. Miller, Vice-Commander

RETIREMENTS

Recent retirements from the Laboratories include W. J. TURNER, with thirty-five years of service; L. W. KELSAY, thirty-four years; and P. A. DOSCHER, thirty years.

PETER A. DOSCHER

Peter Doscher has been an accountant all his life, and he is both proud and happy about it. Entering Western Electric in 1918, for ten years he supervised the expense accounting group, with responsibility for the classification of records of expenditures and preparation of expense control reports. He then took up preparation of invoices to A T & T and Western Electric for cost of work performed. His final job, which began in 1942, was auditing of employees' vouchers. That has brought him into contact with all of us who travel, or spend money in the Laboratories' behalf. These human contacts, on all levels, are full of satisfaction, for Mr. Doscher likes people and so likes to work with them.



P. A. DOSCHER

L. W. KELSAY

That liking for people has kept Mr. Doscher active for years in his local civic association at Gibson, Long Island, and as an elder in his church. Life, he says, begins at sixty-five; he expects to add many more years to the 42 of his marriage; to enjoy his five children; and to achieve a practical sort of immortality in his six grandchildren.

WALTER J. TURNER

When Walter Turner was nine years old, he began to play with electrical gadgets, and twelve years later, with a B.S. from Cooper Union (1904), he got a job with Western Electric in our present West Street Building. After a break in service, he rejoined in 1916, as a draftsman. In a couple of years he went over to circuit descriptions, and in 1922 he took up analysis and laboratory testing of step-by-step and PBX circuits. On the strength

of this work, Cooper Union awarded him the E.E. degree in 1928. From 1936 on, he has had charge of the rapid-record oscillographs in the switching development laboratories, keeping them in order and advising engineers on how to use them most effectively. When cathode-ray oscillographs were introduced, Mr. Turner made a thorough study of their capabilities and learned how to service them. Something along those lines seems to him a likely activity after retirement.

Retiring and studious as a lad, Mr. Turner has recently discovered how much satisfaction there is in rubbing shoulders with younger people. And there is no irony in the gifts some of his associates gave him at retirement: the tennis racket will be useful to him in the summer and the skis in winter. With a good heart and a record of one day's sickness in 15 years, he is looking forward eagerly to the cold clear air of the long New Hampshire snow slopes.

LEROY W. KELSAY

Shortly after the turn of the century, Leroy Wilson Kelsay entered the Bell System as a draftsman for the Western Electric Company. Four years later he accepted an assignment with the City of New York on the fundamental design of municipal drainage systems and apparatus for use in such systems, but passage of time could not dim his first love for telephone work and he reentered the

Skis and a tennis racket were given to W. J. Turner upon his retirement. Left to right: J. D. Beatty, Mr. Turner and J. C. Roe



Bell System in 1918 as a draftsman at West Street. His unique ability as a designer soon became apparent and he was transferred to the apparatus design group as design engineer, where he took up work on cable terminal and protective apparatus. Since 1927, when the Outside Plant Development Department was formed, he has been in charge of the group having to do with this class of apparatus. Among his many contributions in this field are the present 98-type station protector, the compact unit types of building and cross-connecting terminals, a water-tight terminal for underground distribution, terminals for J carrier and coaxial cables. His latest efforts have resulted in the design of a unit type combined cable terminal and protector as well as the design of a more compact and moisture-resistant station protector. There are 16 patents (4 pending) in his name.

During the war, Mr. Kelsay was actively engaged in the design of torpedo controls, apparatus for underwater sound, and pressure-tight seals for airborne apparatus.

Mr. Kelsay has recently constructed a new home at West Point Pleasant on the Metedeconk River and will welcome all his many Bell System friends who may be in the vicinity. Although he expects to do quite a bit of fishing, we strongly suspect that his main hobby will still be mechanical design and model making in his well-equipped basement shop. The Kelsay name will remain on the active roll of the Laboratories, for it is also borne by his son, L. W. Kelsay, Jr., a supervisor in the Electronic Development Department.

TWX Traffic Increases

Bell System teletypewriter exchange service, which was first placed in operation in 1931, is entering its eighteenth year with a steady increase in the number of calls. For September, the average number of TWX business day calls handled by Long Lines stood at 23,241—or 11.2 per cent higher than for the same month a year ago.

This Month's Cover Photo

How many of the more recent developments of the Laboratories can you spot on the cover photograph? A close inspection will show carbon resistors, thermistors and varistors; U, UA, UB and mercury relays; ADP, EDT and quartz crystals, glass-sealed crystal units, and a model of a crystal lattice structure; Alpeth and Lepeth cables; video pair and tree wire; subscriber's combined handset; operator's set; cords; vacuum tubes; Selectron terminal strip; V3 repeaters; teletype tape; police and train

radio; models of the Transistor, cloverleaf antenna, metal lens and Jackie Jones microwave repeater station; cold-cathode-tube test set; relay time measuring set; and level distribution register.

As to the Santa Claus, Thomas G. Jones, it



Putting the finishing touches to the props for the cover picture—Helen McLoughlin, R. L. Shepherd, with Nick Lazarnick, the photographer, directing

is his second appearance in the RECORD this year—the first being in the January issue where he was shown at a party given to servicemen's children by the Red Cross in Flushing at which gifts, presented by the Laboratories Doll and Toy Committee, were distributed.

The editors wish to express their appreciation to all members of the Laboratories who supplied the apparatus pictured.

Laboratories' Woman Sponsors First DP Arrivals

To Helen Krowitz of the Building Service Department goes the honor of receiving into her home the first immigrants to debark in New York under the Displaced Persons Law. They were her husband's kin, Mr. and Mrs. Czarnodolskij and their seven-year-old daughter, Irene. Survivors of concentration camps and bombings, they were lucky enough to get in touch with Mrs. Krowitz and have her sponsor them in this country. Arriving on November 4, the family went to the Ukrainian Church on East Seventh Street the following morning to kneel in thanksgiving for their safe arrival in this new land, as immigrants have since the Pilgrims' coming. The happy trio have since left Mrs. Krowitz's home and are established in their own apartment in the Bronx, where little Irene has started school.

Photo Forum

On Wednesday, October 20, the Photo Forum sponsored an unusually fine demonstration on portrait make-up by Miss B. Brigham, well known for her skill in this art.

Selecting a "model" from the audience, Miss Brigham made up one side of her face to look like an old woman, the other side to look like a movie star. The trick, she explained, was to emphasize the wrinkles to register age, and smooth out skin texture for youth. Full lips indicate youth; thin lips, age. Miss Brigham

Principles of Electricity, under W. T. Sermeus, the class with heaviest enrollment; *Scientific Russian Translation*, under B. J. Kinsburg; *Manufacturing Methods*, under R. H. Gertz; *Engineering Materials*, with members of the Chemical Laboratories' staff as instructors; *Telephone Switching*, under the staff of the Systems Department's Switching School; *Advanced Seminar on Thermistors, Varistors and Transistors*, under J. A. Becker; *Blueprint Reading*, under A. S. Lawrence; and *First Aid—Standard Course*, under L. E. Coon.



Under the skillful hands of Miss Brigham, Theresa Treanor becomes old or young, depending on the angle

says the Photo Forum is a division of the Bell Laboratories Club. All members of the Laboratories are invited to attend its lectures, which are held the third Wednesday of each month in the West Street Auditorium.

Murray Hill Symphony

The Murray Hill Symphony Orchestra is extending to Whippany employees who play musical instruments an opportunity to participate in orchestra activities. The group meets every Tuesday evening from 5:45 to 7:30 p.m. Those Whippany employees who play stringed instruments are particularly encouraged to come to rehearsals.

The Out-of-Hour Courses

After hours, some 142 members of the Laboratories are pursuing courses offered this fall by the Personnel Department in cooperation with Technical and Staff Departments. Known as The Out-of-Hour Courses, these classes afford an opportunity to study *Elementary*

M. L. Clarke Presidential Elector

M. L. Clarke cast one of the forty-seven votes for New York State in the Electoral College when it convened in Washington. Mr. Clarke received this singular honor in recognition of his activities in politics in Nassau and Suffolk Counties on Long Island. He cast his vote in accordance with the popular vote in this state and his vote, with that of 530 other electors, will be sent to Congress, where the President of the Senate will have them counted before both houses of Congress.

Mr. Clarke joined the D & R as a cryptographer under J. J. Carty, in the early days of transatlantic telephone development, having had experience in decoding and ciphering telegraphy in the Commercial Cable Company and an export firm with which he previously worked. Since the D & R consolidation in 1934, he has been engaged chiefly in Central Instrument Bureau work and in electrical inspection and testing; he is now responsible for that group and for office machine services.

December Service Anniversaries of Members of the Laboratories

40 years	30 years	J. B. Dixon	G. V. Dale	Charles Maggs	15 years
Frank Waldman	R. O. Covell	C. A. Johnson, Jr.	Winifred Danwitz	J. P. Mahoney	Arthur Albanese
	J. D. Kilgallen	Mary Routhier	John Deininger	August Mendizza	E. J. Dall
	H. T. Langabeer	Violet Stalhand	G. T. Ford	A. C. Peterson, Jr.	W. D. Elliott, Jr.
35 years	T. J. O'Neill		A. V. Frolic	Susie Terracciano	H. W. Hinz
E. G. Hilyard		20 years	A. W. Gally	Barbara Vatter	F. A. Janiszewski, Jr.
P. B. Murphy	25 years	S. M. Arnold	J. J. Harley	C. P. Voltz	C. H. Trenkle
J. B. Retallack	E. L. Dias	J. F. Barry	William Herriott	F. J. Zebrowski	10 years
					Regina Zell

We See by the Papers, that—

The Institute of Advanced Study at Princeton University will receive more than \$200,000 left by Leon J. Sivian, research worker of the Bell Telephone Laboratories.

Mr. Sivian, who lived in Summit, died September 23, 1947. He left personal gifts to friends, and the residue to the institute in memory of his former teacher, Dr. Floyd K. Richtmyer of Princeton.—*Morristown Daily Record*, October 23, 1948.

Halloween at the Westchester County Home was a day which will be long remembered. At the annual costume party, Mrs. Caroline Thomas, chairman, presented the Home with a new public address system and movie amplifier.

Although the pressing need for this type of equipment has long been recognized, it had remained financially impossible to execute plans for its installation. Thanks for the realization of this project go to Mrs. Thomas and to R. F. Massonneau and his co-worker, Donald Robertson, members of the technical staff of the Bell Telephone Laboratories. Through their generous donation of time and talent, this modern equipment, which they designed especially to fit the acoustics of the auditorium, has been built and installed.—*Scarsdale Enquirer*, November 5, 1948.

Mathematics for Engineers and Scientists

A recent addition to the Bell Laboratories' series of books published by D. Van Nostrand is *Applied Mathematics for Engineers and Scientists*, by Dr. S. A. Schelkunoff. As the author points out in the preface, books on *Higher Mathematics for Engineers* that met the needs of engineers only a short time ago are no longer adequate. Without more advanced mathematical knowledge, many recent achievements cannot be fully understood. The purpose of this new book is to bring *Higher Mathematics for Scientists and Engineers* up to date. In general, it is devoted to those

branches of mathematics that are needed in mathematical physics and engineering.

Another addition to the Van Nostrand list is a second edition of *Electromechanical Transducers and Wave Filters*, by W. P. Mason. In this new edition, the author has incorporated a number of additional topics, some of them growing out of work he carried on during World War II.

Copies of either book may be purchased by calling extension 260 at West Street or extension 536 at Murray Hill.

Pensioners Note Receipt Change

Every month the Bankers Trust Company, Trustee of our Pension Fund, mails checks directly to banks if and as directed by the pensioner. Since those checks are not personally endorsed, it is the part of prudence to secure a personal acknowledgment of the payment by return of a receipt form sent by the Trustee. Heretofore these forms have been sent monthly, but from now on they will be mailed at six months' intervals, in February and August of each year. The receipt form has been changed slightly to clarify the fact that the pensioner is acknowledging that his checks are being credited to his bank account.



November 29: First snow at Murray Hill

RECENT DEATHS



R. R. IRELAND
1879-1948



E. C. ERICKSON
1900-1948



J. A. ASHWORTH
1910-1948

ROY R. IRELAND, October 26

Mr. Ireland's retirement in 1937 brought to a close a thirty-four-year career in the Bell System which began in 1903. A graduate of the University of Minnesota with a B.S. in 1901 and an E.E. in 1903, he entered the student course of Western Electric in Chicago and transferred in 1905 to the Engineering Department at Clinton Street. Four years later, in New York, he became associated with apparatus development activities and had a part in the design of subscriber station and central office apparatus. Later he spent another year at Hawthorne. During World War I, he designed submarine listening devices in New London, returning in 1919 to the Apparatus and Specifications Department. Eight years later he was made Specifications Engineer in charge of the department, the position he held until his retirement.

JOSEPH A. ASHWORTH, November 3

A specialist in the study of magnetic materials, Mr. Ashworth joined the Research Department in 1928 as a Technical Assistant and worked on submarine cable loading and loading coils until 1933. At that time he accepted a scholarship to the California Institute of Technology, from which he received his B.S. degree in 1935. Following a year of graduate study at Duke University, he returned to the Apparatus Development Department in 1936, where he engaged in a study of the properties and applications of magnetic materials. During the war he made important contributions to the development of magnetic mines and submarine devices. Since then, he had been engaged in studies of the use of magnetic materials in telephone apparatus, particularly in new designs of transformers, telephone receivers and relays. He was chairman of the A.S.T.M. subcommittee on magnetic materials.

Mr. Ashworth was a Boy Scout patron, having served on numerous scouting committees. He was a musician of note and had played the saxophone, clarinet and, more recently, the flute in the Murray Hill Symphony Orchestra.

ELMER C. ERICKSON, October 29

Within a few months after receiving the B.S. degree from Princeton University in 1922, Mr. Erickson joined the Transmission Apparatus group, where he engaged in designing condensers and loading coils. In 1928 he began specializing in precision linear measurements. For the past twenty years he had charge of precision length and thickness measurement work, to which he had contributed a number of new methods for special measurement problems. He was active in the A.S.A. work on the standardization of screw threads and measurements of surface roughness.

Mr. Erickson had been active in work of the school board in Wood-Ridge, New Jersey, where he resided, and of the First Presbyterian Church in that community in which he had served as an elder for many years.

News Notes

A. B. CLARK attended the New York Telephone Company Manhattan-Bronx-Westchester Area Operating Conference, November 7-10, at Skytop, Pennsylvania, and gave a talk on the work of the Laboratories.

DURING October and early November, G. D. EDWARDS visited the territories of the Southwestern Bell Telephone Company and The Pacific Telephone and Telegraph Company, where he discussed the work of the Quality Assurance Department and quality matters in general with Long Lines, Operating Company and Western Electric people. In the course of his trip, Mr. Edwards introduced R. V. DEAN, who will have charge of the Laboratories new

Field Office in Dallas, and R. E. JOHNSON, who will have charge of the newly reopened Field Office in Los Angeles. On his way home, Mr. Edwards attended, in Chicago, the Third Conference of the Mid-West Sections of the American Society for Quality Control, of which he is past president.

HARVEY FLETCHER attended a meeting in New York of the American Standards Association Sectional Committee on Letter Symbols and Abbreviations and a meeting in Washington of the Committee on Hearing, National Research Council Division of Medical Sciences. Dr. Fletcher attended the annual meeting, in Columbus, of the Ohio State Research Foundation, of which he is a member. From Columbus, he went to Cleveland for meetings of the Acoustical Society of America. Dr. Fletcher also attended the joint meeting of the Institute of Radio Engineers and R.M.A. Engineering Department in Rochester, where he spoke on *Hearing, the Determining Factor for High-Fidelity Transmission*. At the invitation of the Standard Oil Development Company, he went to the dedication of the Esso Research Center.

W. H. BRATTAIN spoke on *The Transistor—Its Properties and Characteristics*, and P. H. SMITH on *A High-Gain Cloverleaf Antenna* at the meeting in Chicago of the National Electronics Conference.

W. P. MASON participated in a *Symposium on Ultrasonics and Macromolecules*, held at Brooklyn Poly, at which he gave a paper, *Mechanical Properties of High-Polymer Liquids at Ultrasonic Frequencies*.

W. SHOCKLEY and J. A. BECKER presented a paper on *The Transistor—a Crystal Triode* before a joint meeting of the New York Sections of the A.I.E.E. and I.R.E., sponsored by Basic Science and Communication Groups.

H. J. WILLIAMS gave a demonstration lecture on *Ferromagnetic Domains*, the first in a *Symposium on Ferromagnetic Circuits*, given under the auspices of the New York Section, A.I.E.E., Basic Science Group. He was assisted in the demonstration by J. G. WALKER.

A. C. GILMORE took a trip to several towns in Connecticut in connection with studies of a new toll switchboard.

A. A. BURGESS and W. J. RUTTER were at Philadelphia in connection with special central office equipment.

J. G. FERGUSON observed the installation of the Willoughby No. 5 office in Cleveland.

R. O. SOFFEL at Richmond witnessed tests on new reed signaling for mobile radio telephone.

O. CESAREO, A. P. GOETZE and J. R. IRWIN observed the Naval Research Laboratories' computer in Washington on October 14.

A. E. JOEL delivered a paper on *Relay Lockout Circuits*, and F. J. SINGER a paper on *Military Teletypewriter System of World War II* before the Milwaukee Convention of the A.I.E.E.

R. B. HEARN, R. S. CARUTHERS, R. L. CASE, W. L. GAINES, D. L. MOODY and L. PEDERSEN visited Madison and Milwaukee in connection with N1 carrier trials.



V. L. Ronci conducts Fred Lack, vice-president of Western Electric Company, with L. C. Jarvis, superintendent of manufacture of the Allentown plant, through the Allentown laboratory of Bell Telephone Laboratories during the recent open house at this modern, new Western Electric plant described on page 502. The Laboratories provided a group of displays, including the Transistor, simulated electron tube, the latest electron tubes, and photo murals showing BTL locations

F. E. BLOUNT investigated automatic monitor problems at Media.

F. M. PEARSALL visited the Teletype Corporation in Chicago in connection with problems associated with trouble recorders for the No. 5 crossbar system.

T. D. ROBB, L. L. BLANE and G. W. WEAVER observed a new switchboard used at Englewood, New Jersey, as a DSA board for Fort Lee and Leonia No. 1 crossbar offices.

T. H. NEELY visited the Paterson No. 3 toll office in connection with trunks to the 1B toll tandem at Newark.



Nurse Thomas, in the West Street Medical Department, vaccinating one of the members of the Laboratories who took advantage of the opportunity to be inoculated against influenza. Vaccinations were given at all locations

J. BAUMFALK, A. C. GILMORE and E. VON NOSTITZ visited Manchester, Danielson and Norwalk, Connecticut, to observe the operation of Nos. 3C and 3CL toll switchboards and associated equipment, which functions with Southern New England operator's tandem system and the newly installed Gotham tandem system in New York City.

U. B. THOMAS, R. D. DEKAY and L. A. LEATHERMAN discussed nickel-cadmium batteries with Southern New England Telephone Company in New Haven.

R. M. BURNS, H. E. HARING, K. G. COMPTON, U. B. THOMAS, V. J. ALBANO and M. SPARKS attended the Electrochemical Society conven-

tion in New York City. U. B. Thomas was elected secretary-treasurer of the Battery Division at this convention, at which he also presented a paper on *The Electrical Conductivity of Lead Dioxide*.

R. L. LUNSFORD, H. A. MILOCHE and F. W. TREPTOW attended a conference at Hawthorne on metal joining.

K. M. OLSEN visited Point Breeze in connection with lead cable sheath problems.

J. H. SCAFF and K. M. OLSEN conferred at Allentown on problems associated with processing of silicon for rectifier use.

V. J. ALBANO studied Alpeh cable sheath in Pittsburgh.

A. C. WALKER gave a talk on *Growing Piezoelectric Crystals* before the New York Chapter of Alpha Chi Sigma at the Hotel Duane.

H. W. HERMANCE and T. F. EGAN inspected contact trials in Philadelphia central offices.

T. F. EGAN attended the A.S.T.M. Colloquium on Electrical Contacts at Massachusetts Institute of Technology.

J. H. SCAFF, W. C. ELLIS, A. G. SOUDEN, F. J. SCHNETTLER and R. A. CHEGWIDEN attended the National Metals Congress in Philadelphia.

R. A. CHEGWIDEN, V. E. LEGG and the late J. A. ASHWORTH consulted the Magnetic Metals Company in Camden on various problems relating to magnetic materials.

F. J. BIONDI attended a meeting of the A.S.T.M. Committee B-4 on cathode nickel at Cambridge.

←Whippany highlight: Printer operator





Bell Laboratories Ceramic Club

Left—Fred Frampton and Julia Haege in front of the kiln in which his candy dish and her ash tray were fired

Center, left—Charles Koch, left, learns from the instructor how to roll clay properly, while John Weller, right, prepares to knead his clay on the plaster bat

Lower, left—Winifred Meszaros, right, helping Ruth Boyajian to cut clay for a cigarette box, using a cardboard pattern

Below—Jack Wolfe, nationally known ceramist and editor, giving instruction to a group of Laboratories Club members at his studio in 62 Horatio Street near the West Street building



News Notes

W. G. PFANN presented a paper before the Basic Sciences Group at the A.I.E.E. meeting in Milwaukee on *Bridge Erosion in Electrical Contacts and Its Prevention*.

P. P. DEBYE, E. K. JAYCOX and G. R. PRICE attended the thirty-third annual meeting of the Optical Society of America, held October 21-23 in Detroit.

K. G. COUTLEE, H. A. BIRDSALL, C. J. FROSCH, W. MCMAHON and D. A. MCLEAN attended the conference on insulation, Committee on Industrial and Engineering Research, National Research Council, held at the National Bureau of Standards in Washington. At this meeting, Mr. Birdsall spoke on *A Mercury Electrode Test for Capacitor Paper*, and Mr. McMahon discussed *Influence of Field During Freezing on the Dielectric Constant of Certain Wax-like Dielectrics*.

News Notes

AT THE Orrville, Ohio, plant of the Koppers Company, J. LEUTRITZ treated specimens of wood which are to be used in a coöperative study of creosote. He also attended a meeting of the Preservatives Committee of the American Wood Preservatives Association, Chicago.

R. C. PLATOW was elected chairman of Subcommittee on Research of the A.S.T.M. Committee on Adhesives.

E. S. GREINER presented a paper, coauthored by W. C. ELLIS, on *Thermal and Electrical Properties of Ductile Titanium* at the A.I.M.E. meeting in Philadelphia.

E. K. JAYCOX, H. E. JOHNSON, C. L. LUKE and L. A. WOOTEN participated in a conference on standardization of methods of chemical analysis at Point Breeze.

J. R. TOWNSEND and F. S. MALM inspected the drop wire plant and discussed materials problems at the Western Electric Company in Baltimore. Mr. Townsend attended a meeting at the Navy Industrial Association in Washington. He was elected vice-chairman of the Standards Council of the American Standards Association at the annual meeting in New York.

O. B. COOK and M. BROTHERTON appeared in the Morristown Little Theatre's presentation of "Arsenic and Old Lace," with J. J. JOHNSTON acting as production manager and HELEN BENZ as an usherette. Also appearing before the footlights was Boyd Nichols of the Watson Laboratories, U. S. Air Corps, who is at present stationed at Whippany.

L. R. SNOKE and L. H. CAMPBELL made observations of cleanliness characteristics of treated pine poles at Allentown and Harrisburg.



The Metropolitan Bell Symphony Orchestra made its debut at Carnegie Hall, November 12. With Michel Gusikoff, distinguished conductor, and Marisa Regules, brilliant young pianist from Argentina, performing as guest star, the orchestra won enthusiastic response from an audience of almost 2,000. Since its official organization on May 20, 1948, with 36 members, the orchestra now numbers more than 100 Bell System musicians, drawn from Bell System companies in the Metropolitan district. BTL players are: R. E. Anderson, B. Bogert, R. N. Breed, P. G. Edwards, R. D. Fracassi, J. C. Gabriel, H. C. Green, R. V. Hatch, A. F. Hughes, W. A. Krueger, W. R. Lundry, P. E. Mills and A. L. Whitman

J. R. BOETTLER investigated presses for powder metallurgy at the Stokes Manufacturing Company in Philadelphia.

L. E. ABBOTT visited the Revere Copper and Brass Company at Rome, New York, on matters of waveguide tubing.

J. P. GUERARD visited the American Brass Company and Chase Brass and Copper Company in Waterbury, Connecticut.

C. S. FULLER addressed the Polymer Lecture Group at the University of Akron on *Polymer Structure in Relation to the Uses of Plastics*.

L. E. ABBOTT attended meetings of the American Welding Society in Philadelphia.

W. E. KOCK and F. K. HARVEY discussed *Refracting Sound Waves* and demonstrated several types of refractors at the meeting of the colloquium, held at Deal on November 12.



New Lounge and Game Room at West Street

On this page are pictures of the new game room in the IH Section and of the recently re-furnished Club Lounge adjoining it. Newly covered in two shades of green and in russet leather, the Lounge furniture sets the scheme for the rest of the decorations. Walls are two shades of green, drapes green and russet, and the lamps are rose, green and wheat color.





Engineers Are Engineers Even in Japan

The following letter has been received from Frank A. Polkinghorn, on personal leave of absence from the Laboratories, to be Chief of the Research Branch, Civil Communications Section, Tokyo.

"I thought you might be interested to have a copy of the first issue of a paper which is to serve the same purpose in the Electrical Communication Laboratory of the Ministry of Communication as the BELL LABORATORIES RECORD does for the Bell Telephone Laboratories.

"Japanese engineers notoriously like to go off in a corner and do only the kind of work in which they are interested, without any regard to its value to the telephone system. The cartoon shows the Plant Department calling for a better telephone and the laboratory engineers hurrying down from their ivory tower to give them one. We hope that it works that way.

"My regards to inquiring friends."

News Notes

I. V. WILLIAMS attended meetings of the American Society for Metals in Philadelphia.

"The Telephone Hour"

NBC, Monday Nights, 9:00 p.m.

December 13	Lily Pons
December 20	John Charles Thomas
December 27	Robert Casadeseus
January 3	Pia Tassinari and Ferruccio Tagliavini
January 10	Marian Anderson

F. S. MALM was appointed a member of the Nominating Committee in the Twenty-Five-Year Club of the Rubber Division of the American Chemical Society.

R. K. POTTER attended the Washington meeting of the Society of Motion Picture Engineers, at which he discussed an outside interest he has had in the *Possibilities of a Visible Music*.

A. B. CRAWFORD participated in a round table discussion on *Tropospheric Propagation*, scheduled as part of the Symposium on Communication Research, held October 11-13 in Washington. D. H. RING also attended the Symposium.

S. D. ROBERTSON was at Ohio State University from October 19 to 24 in connection with recruiting of engineering personnel.

D. E. CAVENAUGH visited the Army-Navy Electronic Equipment Standards Agency at Fort Monmouth in connection with hermetically sealed transformers. He also visited the New York Transformer Company at Alpha, New Jersey, in connection with the application of the Flexseal process on open-type power coils.

A. J. GROSSMAN attended a meeting in Washington of the Communications Panel of the Research and Development Board.

F. B. MONELL, R. H. MILLS and F. J. HALLENBECK went to Coles Signal Laboratories, Fort Monmouth, to attend a conference on Army Communications.

K. G. COMPTON gave a talk on corrosion before the Louisville Chapter of the American Society for Metals.

J. R. IRWIN, in Washington, reviewed the condition of the relays in the computer at the Naval Research Laboratory.

J. M. MELICK, R. C. KAMPHAUSEN and M. SALZER assisted the Teletype Corporation in the production of special perforators at their Chicago plant.

E. L. NELSON and R. C. NEWHOUSE discussed naval aircraft radio development with the Bureau of Aeronautics at Washington.

R. F. LANE and A. M. GARBLIK discussed V.H.F. communication tests with engineers of the Air Matériel Command at Wright-Patterson Air Force Base.

R. J. PHILIPPS conferred on drawing requirements at the Bureau of Ships in Washington.

H. L. ROSIER is temporarily assigned to the Patuxent River Naval Air Test Center, assisting the Bureau of Aeronautics in conducting aircraft radio communication tests.