



The No. 23 Auxiliary Operating Room Desk

A telephone central office must provide a number of services in addition to completing telephone connections; information must be made available to local and toll operators and to customers regarding such items as routing of calls, correct numbers, or reasons why calls cannot be completed. Improvements in services are gained by combining facilities for handling them at a single desk.

W. T. SERMEUS

Switching Systems Development

In addition to the various operating services rendered by a telephone office, a number of auxiliary services are provided to speed the handling of calls and to supply customers with the special information they sometimes need. These auxiliary services are necessary to both toll and local operation. Local services include information to either toll operators or customers regarding telephone numbers within the area served by the office, and intercept service. This latter service consists in answering calls that for any reason cannot be completed as they

were originally set up so as to give the present correct number to the calling party or explain that the original number is not available. Toll services include rate and route, ticket filing and distributing, charge quoting, and directory.

These various services are frequently handled by operators at different desks or switchboards, although in smaller cities some or all of them have been combined — in part or in full — at a single desk of the non-call distributing type. Studies indicate, however, that further economies



Fig. 1 – A 23A position in Harrisburg.

could be secured in these smaller cities by fully combining all these auxiliary services at a single call-distributing desk with preferential answering for the four major services in the order in which speed of answer is important to them. The 23-type operating room desk has been developed to provide the facilities required. It provides a number of standard units that may be assembled in various combinations to permit the amount of record space to be varied over a wide range. In addition to this flexibility, floor space requirements have been kept low, and a desk of greatly improved durability and appearance has been obtained by the use of steel and plastic construction. The design of the desk has been guided throughout by modern principles so as to make it outstanding in appearance as well as in the service it provides. The general method of operation and the circuits em-

ployed are described in the next article.

For all of the auxiliary services except toll-ticket filing and distributing and the associated charge quoting, the differences in section design required at the 23 desk are chiefly in the amount of space needed for records. For ticket work, however, the framework, although similar in general appearance, differs substantially from the other sections in design. It provides a large capacity toll-ticket file and facilities for pneumatic tube ticket distributing equipment. This unit is located at the head end of a lineup of other units, and is provided with facilities to house all of the records used at the other units.

Another variable facility obtainable in the 23 desk is the ability to use either automatic call-distributing or key-ended incoming trunks. Where some six or eight or more positions are required, with the resulting comparatively large number of incoming trunks, automatic call distributing is usually justified in the interest of cost and operating efficiency. On the other hand, in cities where a smaller number of positions and trunks satisfy the traffic requirements, automatic call distributing has few advantages, and a desk of lower first cost can be obtained by the use of key-ended trunks, which may be multiplied as required.

To provide for the differences in the number of trunks and positions, in the space required for records, and for either call-distributing or key-ended circuits, the 23 desk has been made available in six physical groupings, the A, B, C, D, E, and F. The 23A, B, C, and D positions are arranged

Fig. 2 – A lineup of seven 23A sections and one 23D section in Harrisburg, arranged for fully combined operation at all positions. An installation of thirty positions of the 23C information desk in the East 13th Street Building in New York City is shown at the top of page 161.

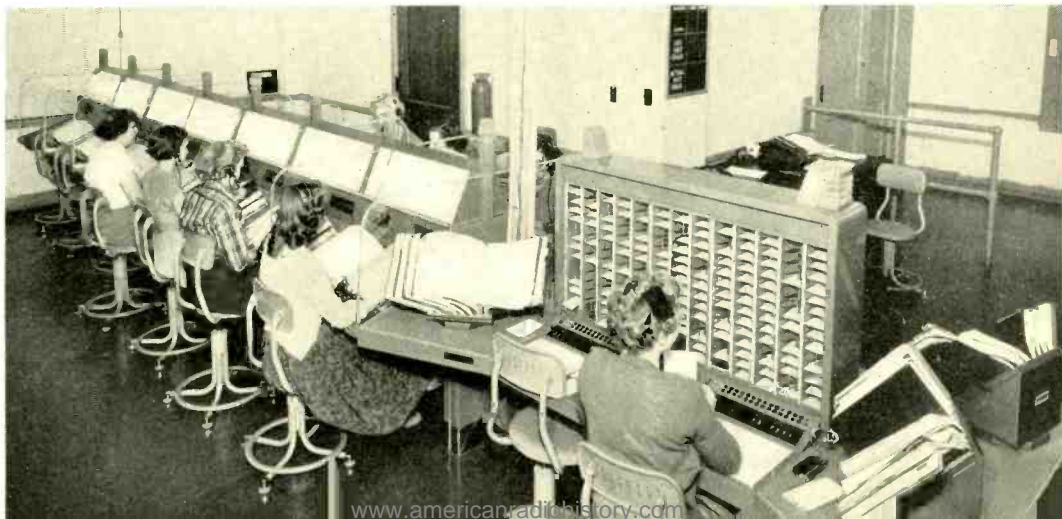

for automatic call distribution. The A, B, and C positions are similar except for the amount of space available for records. The A positions provide adequate space for all toll and local records at fully combined desks. The D positions, arranged to be lined up with the A positions, include space for the same records and also a large capacity ticket file. The 23E and F positions provide for key-ended instead of call-distributing incoming trunks. Otherwise, the 23E positions are similar to the 23D, and the 23F positions are similar to the 23A. An installation of 23A and 23D desks in the Harrisburg operating room is shown in Figure 2. This installation has a lineup of four positions of 23D desk at the right and fourteen positions of 23A desk at the left.

Previous auxiliary service desks, following the usual switchboard practice, have been constructed of wood, usually with mahogany finish, but the 23 desk is a metal desk finished in neutral gray enamel—the first metal design to be used for regular telephone service. A 23A position in the Harrisburg office is shown in Figure 1.

Plan views of the various 23 desk framework units and the lineup arrangements available are shown in Figure 3. As evident from this figure, all forms of the 23 desk are double-sided with operators on each side. The A, B, C, and F desks are made in two-position sections, and the D and E, in four position sections. In front of each A, B, C, or F operator is a sloping book shelf with a key panel above. Between opposite positions of a section is a horizontal shelf on which may be located a directory rack, a double-sided bulletin holder for a frequently-called number list, as shown in Figure 1, or a transparent plastic baffle with a cut-out at the bottom edge to permit two or three small books to be laid on the flat shelf where they will be available to both operators. A fourth option for this space is a somewhat shorter bulletin holder combined with a short directory rack—the two taking the same over-all length as the bulletin holder of Figure 1. All four of these options aid in reducing noise interference between opposite operators.

In the 23A or F desk, space for records continuously open is provided only in front

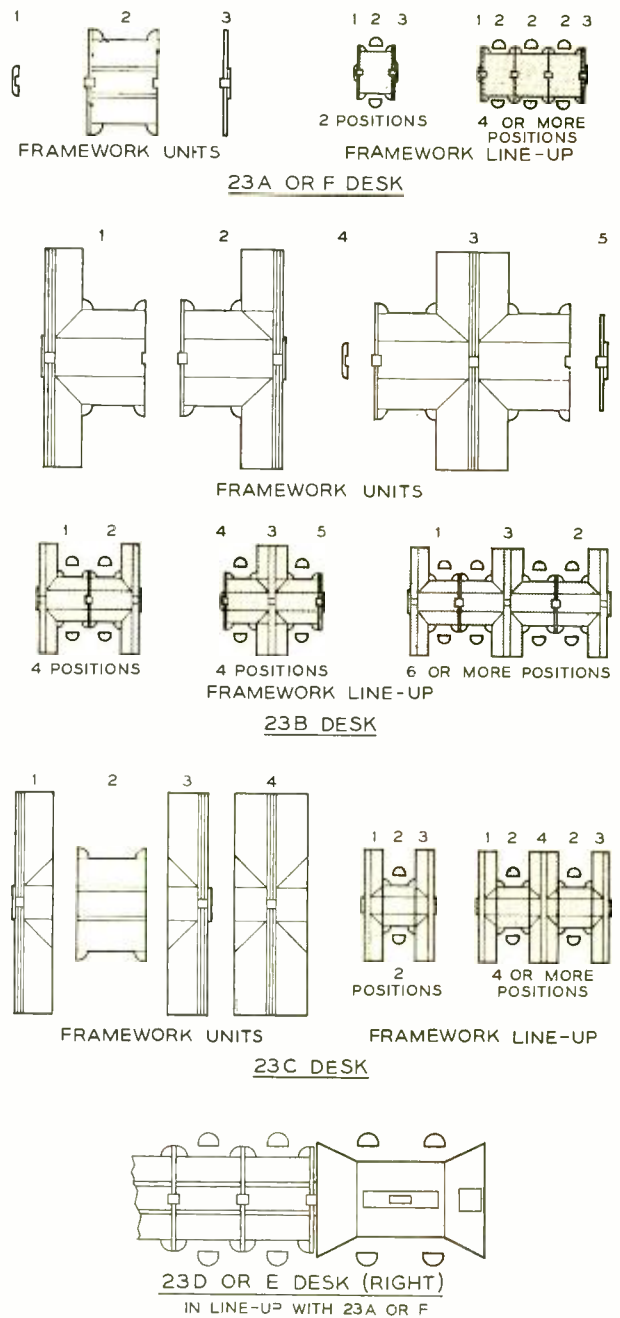

Fig. 3—Plan views of the six forms of the 23-type operating room desk.

of the operator. Where more space is desired for such records, a sloping book shelf flanking the operator on one or both sides may be provided. With one side section, the desk is known as the 23B, and with a section on each side, as the 23C. The latter



Fig. 4 – Part of a lineup of 23C information positions in the East 13th Street Building in New York City.

Fig. 5 – The 23D ticket filing and charge quoting section in Harrisburg.

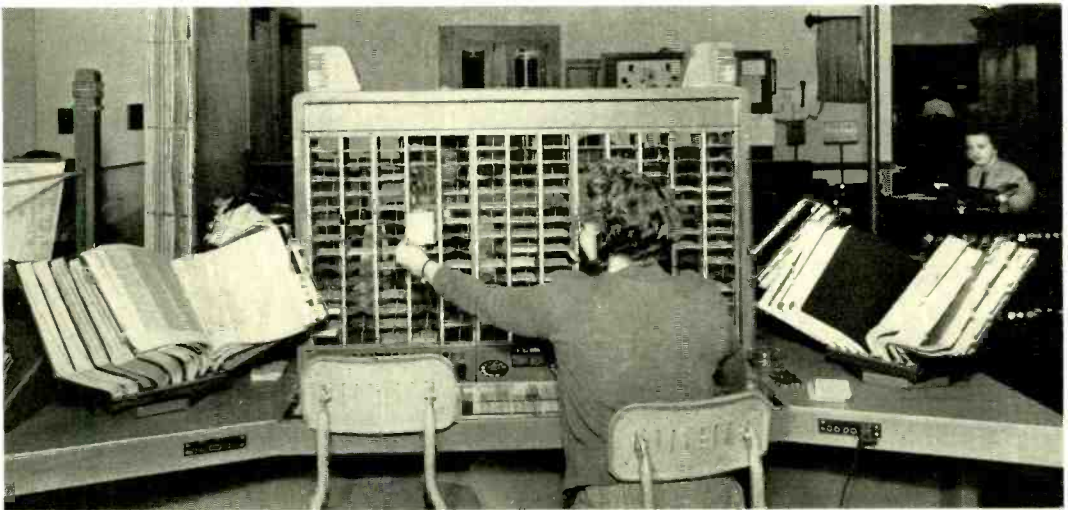

Fig. 6 – A 23D ticket filing and charge quoting section with pneumatic tube ticket distribution and three 23A sections in Pittsburgh, arranged for centralized rate and route, and ticket filing for one toll operating unit.



desk is shown at the head of this article and in more detail in Figure 4.

The ticket desk, 23D or E shown in Figures 2, 3, and 5, is a four-position desk with two operators on each side facing a common ticket filing cabinet. This cabinet normally is provided on each end with five stacks of fourteen ticket compartments each, and thus for a total of 140 compartments, but three more stacks may be put between the two sets of five to secure a total of 182 compartments. In the smaller centers, tickets are brought to the filing desk by messengers or by a track distributing system, but in the larger centers pneumatic tube distributing systems are used. For such locations, the middle three-stack space is used for the tube equipment, as shown at the left of Figure 6, and the space thus obtained is used for receiving and sending tickets via the pneumatic system.

As evident in the illustrations, the sections are installed in a continuous lineup with transparent plastic baffles between them. A cable runway is provided between the facing positions of the lineup so that the switchboard cable enters at one end of the desk and is run to all positions in the lineup. This runway is readily accessible during installation, but is concealed after the desk equipment is installed. It can easily be uncovered at any time for maintenance or to permit the addition of desk positions.

The No. 23 desk is provided with the usual facilities for an operator to call a service assistant to her position. Also at the call distributing A, B, C, and D desks, service assistants' telephone circuits are provided including facilities to transfer a call from the operator to the service assistant,

thereby freeing the operator so that she may resume regular operation. At all positions except the D and E, two steady red lamps per position (one at each end) are provided to indicate the side of desk and exact position which is calling. The D and E positions have only one lamp per position which is mounted on top of the ticket file. In addition, these positions may also have a messenger call lamp per position (steady white) if required. Standard quiet operating room flashing lamps, red for service assistants' calls and white for calls to chief operator's and other desk telephones, are used at certain positions only — in association with the steady red service assistant's position lamps.

To house these various lamps, modern rectangular standards with plastic strip lenses are provided at the ends of each section. The lowest lens, except at D and E positions, with a steady red signal, is used to identify the position calling a service assistant the next higher lens (flashing red) is used to attract the attention of the service assistant, and the top lens (flashing white) is used to indicate a call to be answered at the chief operator's or other desk telephone. At D and E positions, a messenger-call strip lens (steady white) may be used, if required to indicate the position calling a messenger. The two flashing lenses radiate light on all four sides, but the steady position identifying lenses are split, each side lighting to indicate the operator on that side.

Besides the equipment in the desk itself, a certain amount of terminal room equipment is required, including crossbar switches where automatic call distributing is em-



THE AUTHOR: W. T. SERMEUS is chiefly concerned with the development of switchboards and desks associated with manual, dial, and toll systems. He also assisted in the development of a desk for handling all auxiliary services. Mr. Sermeus joined the Laboratories in 1930. In 1938 he entered the trial installation engineering group as a member of the technical staff. During World War II he prepared and taught courses for the Personnel Department. In 1945 he rejoined the trial installation group to engage in further war work and two years later became concerned with switchboard development. Mr. Sermeus received a B.E.E. degree from New York University in 1938.

ployed. This equipment has been designed as small, one- or two-circuit units with surface wiring in accordance with the latest practices. The distribution of the various trunks at a call distributing desk to groups of operators' positions are made at a cross-connecting field which provides flexibility

in assigning these trunks to meet changing traffic conditions.

Not only does this new desk achieve a single standard design for all types of auxiliary service, but it provides for wide flexibility both in the original installation and in its ability to expand.

Dr. Kelly Given Industrial Award

On April 7, the Chamber of Commerce of Greater Philadelphia presented to M. J. Kelly, President of the Laboratories, its 1953 Award, for his "outstanding contribution to American industry." Dr. Kelly was honored as "the leader of one of the world's great research and development organizations, in recognition of his contributions to communications engineering, which have helped to advance his country in peace and war."

The award—a scroll and a check for \$500—was presented at a dinner marking the close of the Chamber's Sixth Annual Production Conference. Dr. Kelly immediately turned the check over to Dr. Carl C. Chambers, dean of the Moore School of Electrical Engineering of the University of Pennsylvania, to aid a deserving upper classman in his field of study. Adalsteinn Gudjohnsen of Iceland, a top-ranking junior majoring in electrical engineering at the Moore School, was the student selected by the faculty.

In his acceptance address on *Contributions of Telephone Research to Materials Conservation*, Dr. Kelly pointed out that such tremendous quantities of the basic materials—inorganic matter—of our planet are being consumed, that there are pessimistic predictions of an ultimate race suicide brought about by the inadequacy of basic materials and the power required by the present pattern of society.

"I have not been impressed by the soundness of the predictions or the analyses that justify them. In fact, my confidence in the power of science and technology and of the resourcefulness of the men of our nation's laboratories leaves me with little concern. Their contributions will make possible the

solution of the scarcity problems as they arise," he said.

He pointed to telephone technology as an impressive case history of the contribution of science and technology to the extension, improvement and economy of an essential service, while decreasing its consumption of inorganic materials.

As an example of how improved telephone technology has reduced the use of natural resources, Dr. Kelly described the evolution of long-distance telephony from the early single-channel system to the latest form of coaxial cable system, the L3, with striking savings in copper and lead for equivalent communication traffic.

Dr. Kelly also mentioned the reduction in size and weight of loading coils; decrease in the diameter of the copper conductors in local telephone plant with the introduction of the new telephone set; and the introduction of a mechanical means of connecting two wires without the use of solder as additional examples of materials savings resulting from telephone technology.

In looking to the future, Dr. Kelly said that many present concerns of research people at the Laboratories give promise of abundant material savings in the future. He predicted that transistors with their small power consumption, subminiature size, reliability, durability, and long life, will make possible basic materials conservation in transmission facilities and switching systems.

Dr. Kelly also gave a talk on *Physical Facilities for Effective Engineering* at the First Annual Management Division Conference of ASME, and a talk at the Symposium of The Chemical Engineers Club of Washington, under the auspices of the American Institute of Chemical Engineers.

The No. 23 Auxiliary Operating Room Desk Circuit Arrangements

W. L. SHAFER, JR.

Switching Systems Development

The circuit for the auxiliary operating room desk described in the preceding article is a common control circuit which makes it possible to receive and distribute the incoming calls rapidly according to the type of auxiliary service required. A preference arrangement results in more efficient handling of calls.

In providing a new desk with call distributing features for the major types of auxiliary service calls incoming to it, a number of new circuit arrangements were needed as well as the new equipment features already described in the article on page 161. An auxiliary service desk of this type is inherently a common-control system, since a common distributing circuit receives all incoming calls and rapidly distributes them to the various positions according to the order in which they were received and the type of auxiliary service required. Since common-control systems serve a large number of circuits in rapid succession, it is essential to insure that trouble arising in the common-control circuit itself will not seriously interfere with the service being given. In large common-control systems, maintenance offers no particular difficulty. A number of common-control circuits are usually required to handle the traffic, and thus one of them may be taken out of service for maintenance work without seriously affecting the over-all service. When only one common-control circuit is required to handle the load, as with the 23 desk, however, the provision of a spare circuit would double the cost of the common-control feature. To avoid such an uneconomical

procedure, only a single common-control circuit is employed, but the important paths in the new circuit are provided in duplicate so that should a failure occur in one path, the other will take over. An alarm is given at the same time so that the trouble may be cleared.

As many as four types of auxiliary services may be provided on a call-distributing basis at the 23 desk: toll rate and route, toll information, intercepting, and local information. Toll rate and route provides information pertaining to routes to be used by outward toll operators and rates to be quoted by them in completing toll calls. Toll information is that given to distant toll operators regarding local telephone numbers needed for the completion of incoming toll calls. Intercepting service is provided for answering calls when for any reason they cannot be completed as originally set up. On such calls, the intercepting operator gives the new number or explains that the original number is not available. Local information is similar to toll information with the exception that a local subscriber requests the information. In addition, toll ticket filing and distributing is handled at this desk as well as charge-quoting service, which on request furnishes a telephone subscriber with the charge made for a toll call

that he had completed some time earlier.

A preferential answer arrangement is ordinarily required on the call-distributed services. On calls involving toll connections, such as those for rate and route or toll information, prompt service is essential, and therefore these two classes of calls are given the first two preferences in the order

positions can handle all of the auxiliary services, call distribution may not be justified and all traffic may be terminated as key ended trunks. When a call comes in on such a trunk, a lamp lights, and as soon as the operator is free she operates the key and answers the call. Operating the key makes the operator's position busy to the

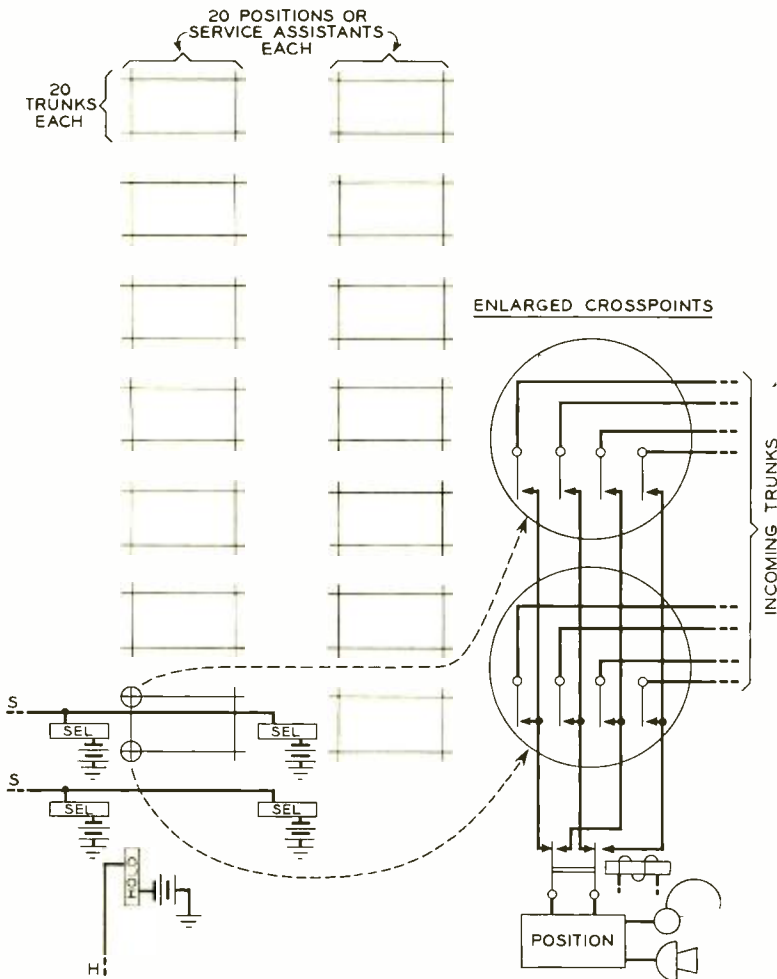

Fig. 1 — Each cross-point of as many as fourteen crossbar switches connects two incoming trunks to the desk position, where one of the two trunks is selected by a relay operation.

listed. Local auxiliary service calls, on the other hand, can stand a slightly longer delay in answer. The circuits of the 23 desk thus provide a preferential answering arrangement that permits rate and route calls to be automatically connected to operators before any other type of call. Toll information is assigned second preference, intercepted calls third, and local information fourth. In small localities, when a few

call distributing system if call distribution is also furnished.

The 23 operating room desk is arranged to provide from one to four preferences or services, depending upon the number of services required at the auxiliary desk. In general, the operators are grouped and the operators of each group handle the same type of services. In very small cities, all services may, in some case, be combined

in one lineup of operating positions. In large cities, on the other hand, some services will be sufficiently large to warrant providing one desk for a single type of service.

Incoming calls to most of the 23 desks are distributed automatically to the desk operator, no key operation being required. The desk operator is informed by a double zip tone and a lighted lamp that the call is connected to her position. She then ascertains what type of service is required, consults the proper record, and gives the report to the originating operator or subscriber. Following disconnect by the operator or calling party, the operator is available for another call. When desired, the call can be transferred to a service assistant, and the regular operator is made available for another call.

As indicated in Figure 1, crossbar switches are used to connect incoming trunks to the operator's positions. Two incoming trunks are associated with each horizontal level of the crossbar switches, and one desk position or service assistant is associated with each vertical unit of the crossbar switch. When the total number of desk positions and service assistants exceeds twenty, two files of crossbar switches are required, with up to seven switches in each. A total of forty desk-operator and service-assistant positions are thus available to handle a maximum of 140 incoming trunks, since each position is associated with the corresponding hold magnets of all the switches in one vertical file. The closure of a crosspoint of the crossbar switch connects two trunks to the vertical file, and a relay permits either one to be selected and connected to the operator.

Calls come in to the preference groups at random, and the control circuit is designed to connect one call at a time through to an operator. Interlinking preference circuits are required to insure that the calls are given preference in accordance with the preference group to which they belong, and that within any one group they are given preference in the approximate order of their arrival. In addition, a selecting circuit is provided that not only will prevent calls from being connected to a position

unless there is an operator to handle it, but also will connect calls to the operators in a group in sequence so as to divide the load equally among them.

The method by which this is accomplished is indicated in block form in Figure 2. There is a chain circuit for the trunks of each group to insure that within each group calls are served in general in the order in which they arrive. Following this is a preference circuit to insure that the calls coming to it from the group chains are served in the order of the preference group to which they belong. Following this circuit is a position selecting circuit that selects

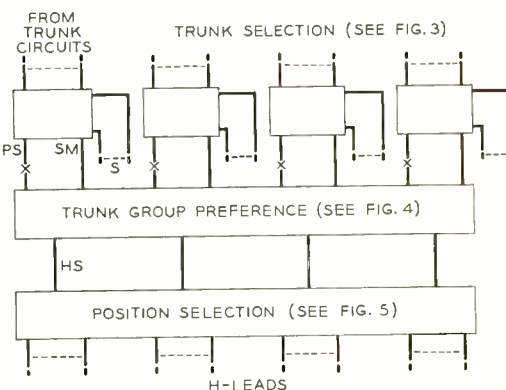

Fig. 2—Incoming calls pass through three preference circuits in tandem: a trunk preference circuit that selects the trunks in a group approximately in the order in which they arrive; a trunk group preference that selects the groups to be served in the order of their preference rating; and a position preference that selects the operators in rotation so as to distribute load among them as evenly as possible.

an idle position of the group to which the call belongs, and that rotates successive calls over the group so as to divide the load equally among the operators.

The chain circuit for each trunk group is arranged as indicated in Figure 3. Each time a call comes in on a trunk, the operation of a relay in a trunk circuit connects battery to the winding of the LO relay associated with that trunk in its chain circuit. Ground is applied to the other ends of the windings of all the relays through a back contact of the G relay. When an LO relay operates, it holds itself operated through one front contact and through another op-

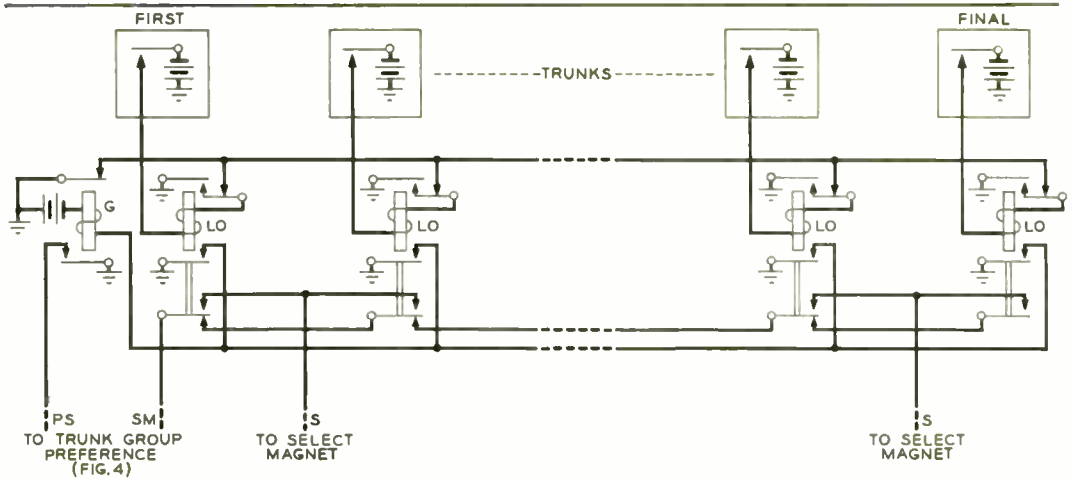

Fig. 3 - Simplified schematic of the preference circuit for each trunk group.

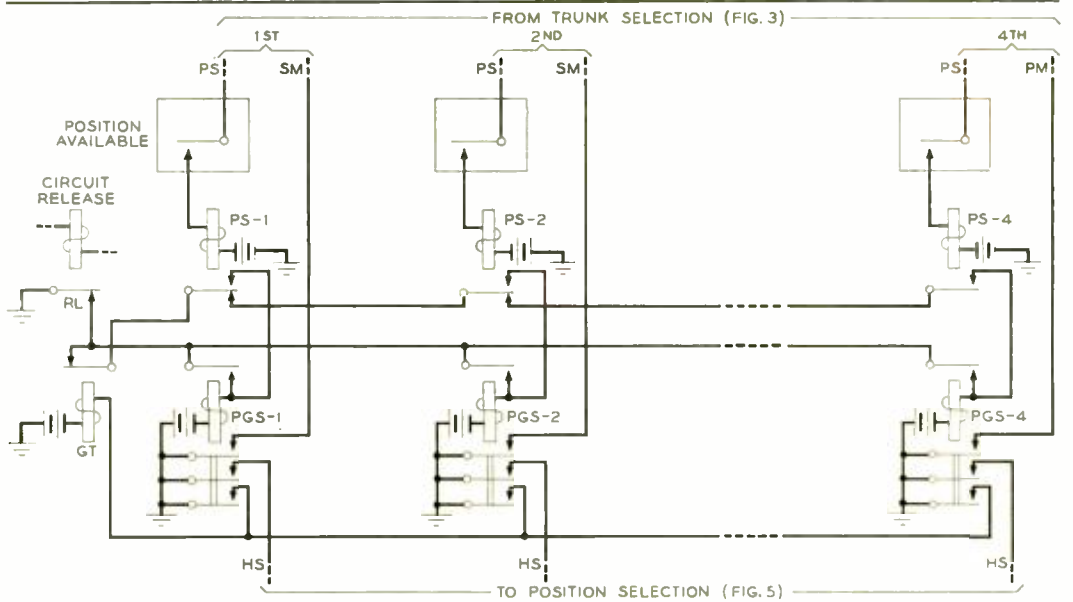

Fig. 4 - Simplified schematic of the trunk group preference circuit.

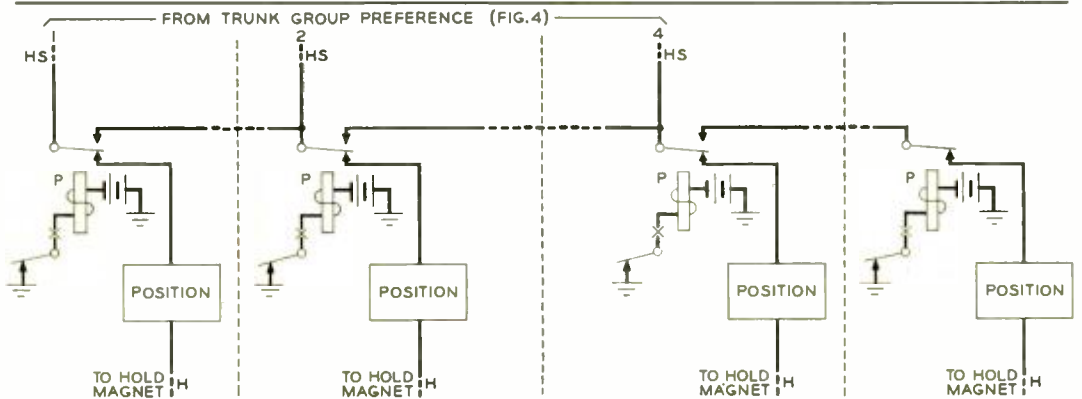

Fig. 5 - Simplified schematic of the operator position preference circuit

crates the *c* relay to remove ground from the remaining *LO* relays. Through another contact on the *LO* relay, a path is closed from an *SM* lead from the preference selection circuit to the select magnet for the calling trunk on the crossbar switch. The operation of the *c* relay, besides removing ground from the trunk group chain, applies ground to a *rs* lead running to the preference selection circuit.

This *rs* lead runs through the circuits of all the positions handling calls of that group, and is closed only when there is a waiting call in that class of service and at least one idle operator available in that group. If this lead is closed in the position circuits, the ground placed on it by the *c* relay in the trunk group chain will operate the associated *rs* relay in the preference selection circuit, shown in Figure 4. There can be as many as four of these *rs* relays, one for each preference group. When one operates, it operates its associated *pcs* relay by ground from a back contact on the common *cr* relay. Relay *pcs* holds itself operated through a front contact and at the same time operates *cr* so that ground will not be available for operating any of the other *pcs* relays. The operation of *pcs* also connects ground to the *sm* lead running to the group chain, whence it operates the select magnet for the calling trunk on the crossbar switch. A relay in this circuit, guided by information from the trunk, also operates the relay in the position circuit that selects one or the other of the two trunks brought down by the operation of

one set of crosspoints on the crossbar switch. In addition, *pcs* connects ground to an *hs* lead running to a position selection circuit.

Since the number of operators assigned to any of the maximum of four preference classes may vary widely, the position selection circuit is a chain that includes all of the positions. It is indicated in very much simplified form in Figure 5. There is a *r* relay for each position, and it will be operated while the position is occupied and the operator is idle, and released when the operator is busy or the position is not occupied. Those positions handling any one of the four preference classes will be associated with adjacent *r* relays. The four *hs* leads from the preference selection circuit connect to a chain running through contacts of all the *r* relays at the first relay of the group associated with their respective classes of service. Although the chain links all the relays, the position selected will be the first available one encountered in the preference group of the incoming call. There will always be at least one idle position in this group or the operating circuit for that group would be open as described in connection with Figure 4. Through the contacts of the first operated *r* relay, the *hs* lead will be extended, through relays in the position circuit, to the hold magnet for that position. Which particular one of the possible seven hold magnets to operate is determined by contacts on the particular select magnet that is operated on the crossbar switch. Since

THE AUTHOR: W. L. SHAFER, JR., joined the Laboratories in 1947 after being graduated from Carnegie Institute of Technology with a B.S. degree in E.E. He became a member of the Switching Systems Development Department and was occupied with circuit design of local manual switchboards and desks. In 1949 he became concerned with the intertoll trunk concentration project, and two years later entered the toll signaling group to work on a military assignment. From 1943 to 1946 Mr. Shafer was in the U. S. Army Signal Corps, where he taught subjects related to telephony.



the control circuit handles only one call at a time, there will be only one select magnet operated at a time. The various parallel paths provided to insure continuous service by the common control circuit have been omitted from the various diagrams for the sake of simplicity.

The operation of these various preference chains, which requires only a small fraction of a second for any one call, insures not only that calls are handled in their order of preference, but that within

a preference group the calls are served in approximately the order in which they arrive, and that the operators in the group are connected to calls in rotation so that no one of them tends to handle more calls than another. The concentration of more than one auxiliary service on one desk accomplishes savings in the number of operators required to handle these types of service, and the preferential grouping of the trunks makes for more efficient handling of calls.

I. R. E. National Convention

Thirty thousand engineers and scientists, representing nearly every country outside the Iron Curtain, attended the 41st National Convention of the Institute of Radio Engineers last month. A four-day program of over 200 technical papers covered the latest advances in such fields as color television, guided missiles, and medical electronics. Over 400 of the country's leading research laboratories and manufacturers staged a ten-million dollar exhibition of electronic apparatus during the convention. Exhibits ranged from devices using diminutive transistors to a full-sized television station for the new UHF band.

Brigadier General David Sarnoff discussed *Electronics and the Engineer* at the annual banquet on Wednesday, and was named the first recipient of the Institute's newly established Founders Award for leadership in the radio-electronic field. John M. Miller of the Naval Research Laboratory was awarded the Institute's highest annual award, the Medal of Honor, for his pioneering scientific and engineering contributions. The second annual presentation of the Vladimir K. Zworykin Prize was to Frank Gray, now retired from Bell Telephone Laboratories, for his outstanding contribution to electronic television.

As President of the I.R.E. for the year,

J. W. McRac was presented with a gavel to open the convention. Four Bell Laboratories men were awarded Fellowships in the Institute: E. B. Ferrell, for contributions and research on high-frequency power amplifiers, servo-mechanisms, telephone switching, and quality control; J. A. Morton, for leadership and contributions in improving transistors and wide-band microwave electron-tubes; S. O. Rice, for mathematical investigations of communication noise, non-linear circuits, and efficient coding of information; and A. A. Roetken, for contributions in developing the transcontinental microwave radio relay system and single-signal radiotelephone receivers.

Dr. Kelly spoke on *Research and Development Problems of Engineering Management in the Electronics Industry* at the Symposium on Engineering Management. S. Darlington and W. R. Bennett presided at two Sections, and two Symposiums included R. L. Wallace, Jr., D. A. Alsberg, D. R. Fewer, and H. G. Follingstad. Other Laboratories men contributing talks were J. J. Scanlon, H. W. Evans, R. M. Ryder, W. R. Sittner, L. B. Valdes, O. Kummer, F. R. Stansel, J. L. Glaser, P. Mertz, and K. W. Pflieger. More information on these talks may be found on page 198, in Talks by Members of the Laboratories.



Ultrasonic Waves Measure the Elastic Properties of Polymers

G. W. WILLARD

Mechanics Research Department

The behavior of various polymers subjected to high frequency deformations determines which types should be chosen for particular applications, such as relay mounts in the telephone plant. This behavior can be predicted from the elastic constants in the material. These constants are calculated from the velocities of ultrasonic waves in the polymers. The ultrasonic velocities, in turn, can be determined by rendering the ultrasonic beam visible through the interaction of two such beams with a light beam.

In the building and processing of polymers — giant molecules of rubbers and plastics — materials having a wide variety of chemical and physical properties can be obtained by varying the manner in which the polymers are formed or the conditions under which they are used. One factor influencing their nature is the temperature; a certain polymer, for example, might be a stiff rubbery solid in the temperature range in which it is to be used, but be a fluid at the elevated temperatures at which it is formed. The mechanical properties differ also as a consequence of the rapidity with which the material is deformed. An amusing silicone polymer called “Silly or Bouncing Putty,” for example, is putty-like when

molded slowly, but stiff and brittle when deformed rapidly as by bouncing or hammering. It would not be so amusing, however, if the rubber compounds used in vehicle tires became stiff and brittle at the higher speeds of deformation encountered in high-speed driving. To be certain that a polymer suggested for use in a particular application will not develop such undesirable characteristics when subjected to extreme conditions, methods must be devised to measure its mechanical properties accurately under any conditions it might experience.

Among the important mechanical properties of polymers, are the elastic constants that are characteristic of them over fre-

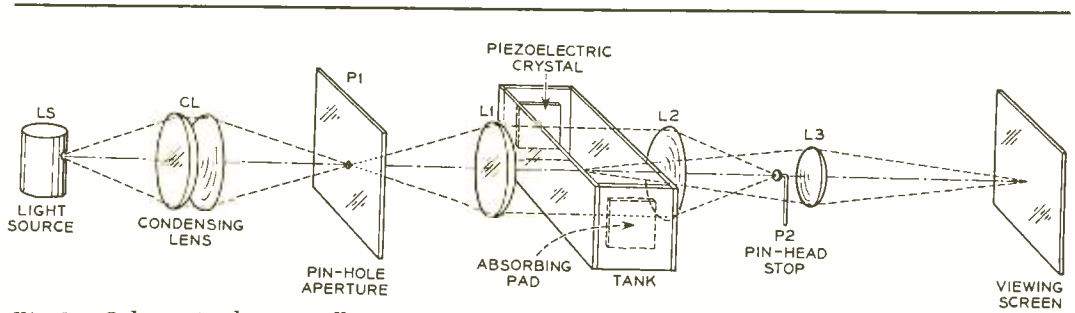

Fig 1 – Schematic diagram illustrating the arrangement of the various components in the ultrasonic light diffraction apparatus.

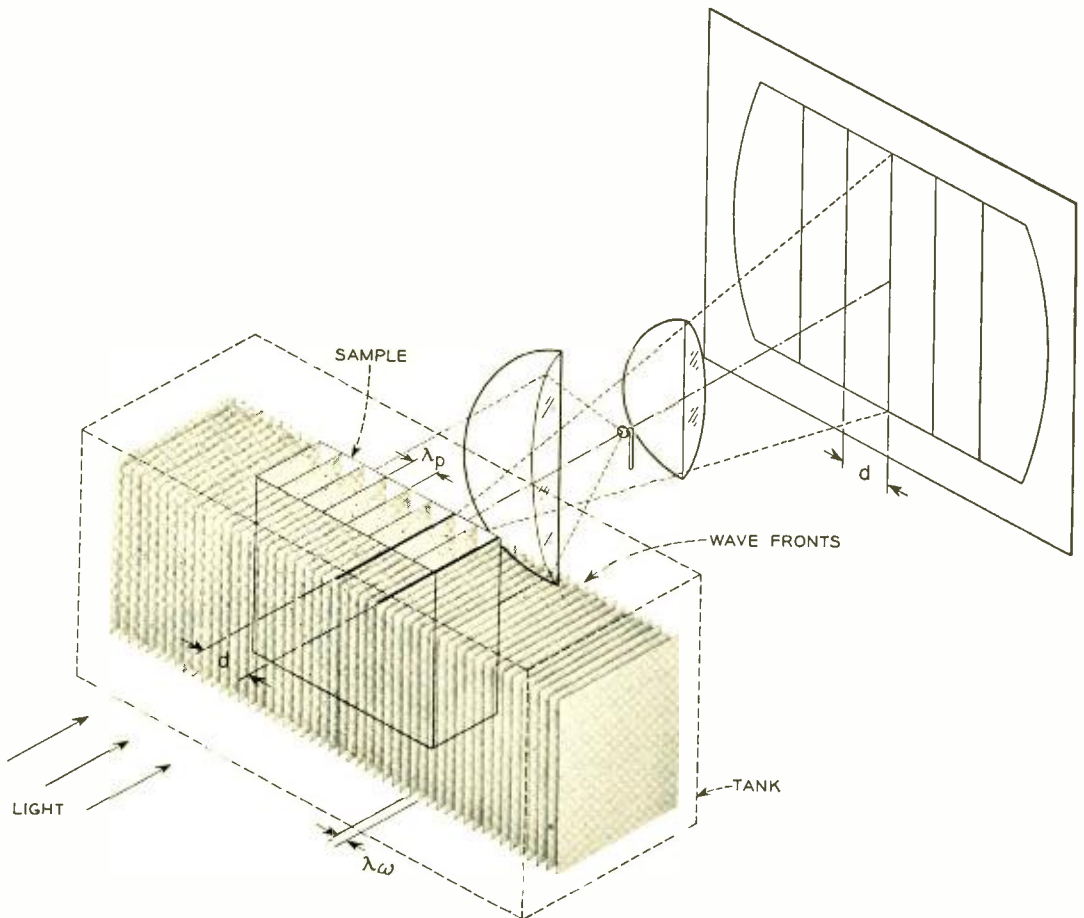

Fig. 2 – Schematic diagram illustrating the ultrasonic wavefronts in water and polymer sample and the resulting band pattern formed on the screen.

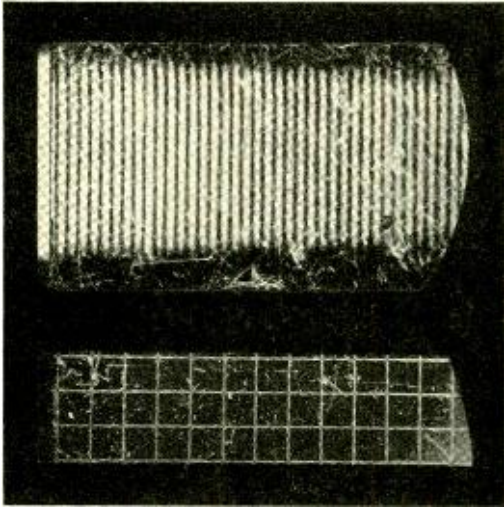

Fig. 3 — Band pattern resulting from the interference of ultrasonic waves as illustrated in Fig. 2.

quencies ranging from millions of deformations per second down to the slowly changing conditions of creep deformation. The apparatus and methods described in this article provide a means of simply and accurately determining the elastic constant in the megacycle frequency range; that is, millions of deformations per second. In this technique, these constants are calculated from a knowledge of the density of the material and the velocity of ultrasonic longitudinal and transverse waves within it. These wave velocities are measured by a special application of an ultrasonic light diffraction apparatus previously described.*

To investigate these wave velocities, the ultrasonic light diffraction apparatus is used to provide a pair of sound beams, one of which passes through the polymer. By the action of these sound beams on a light beam, there is produced on a viewing screen, a light-and-dark, banded pattern. Measurement of the spacing of these bands permits the observer to calculate the sonic velocity in the polymer. The arrangement of the various components in this apparatus is shown in Figure 1. Light from a 100-watt mercury arc lamp is focused by a pair of condenser lenses, labeled CL, onto a pin-hole aperture P1. From this point the light, rendered parallel by the lens L1, passes

* RECORD, May, 1947, page 194.

through an ultrasonic tank. This tank is provided with glass walls and a metal bottom and end plates, with a piezoelectric crystal mounted in one of the end plates and a sound-absorbing pad on the other. When in use, the tank is filled with a liquid, usually water. After passing through the tank, the light is focused by a lens L2 onto a pin-head stop, labeled P2 in the diagram.

These components are aligned on an optical axis, perpendicular to the orientation of the tank, and any light not falling upon the pinhead is focused by the lens L3 onto a viewing screen or photographic plate. When the light is turned on and there is no disturbance in the tank, the screen remains dark since all the light strikes the stop and is either absorbed or reflected by it. However, if a high frequency electric current is applied to the piezoelectric crystal, it will periodically expand and contract and so generate a longitudinal ultrasonic wave in the liquid in the tank. This ultrasonic beam, the cross sectional area of which is about the same as that of the generating crystal, travels the length of the tank and is absorbed by the pad at the other end.

The compressions and rarefactions in this

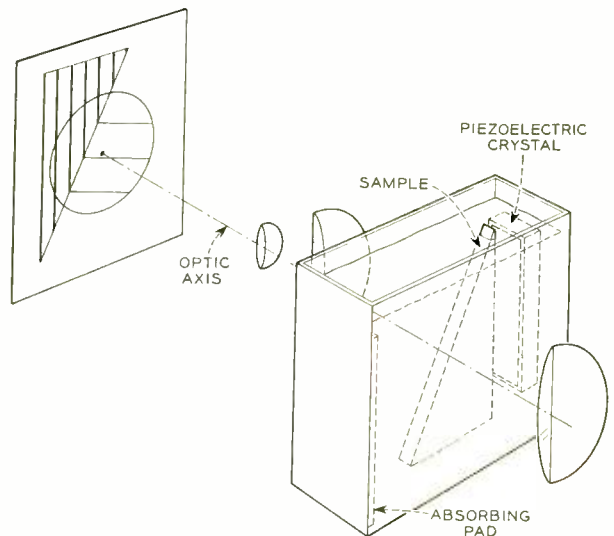

Fig. 4 — Arrangement of the sample in the tank and resulting inverted band pattern on the screen as used in measuring ultrasonic velocities in poorly transparent or opaque polymers.

beam can be regarded as a set of planes oriented parallel to the end plates of the tank and moving constantly through it. These compressions and rarefactions produce regions in the liquid where the optical index of refraction is alternately increased and decreased. Light passing through the tank, as previously described, while these ultrasonic waves are present in the liquid, will be deviated by these optical changes and hence pass by the pinhead stop and strike the viewing screen. In this way, an image of an ultrasonic beam can be formed.

If a block of transparent plastic is placed in the ultrasonic tank in such a way that about half the ultrasonic beam passes through the polymer material and the other half through the liquid next to the sample as illustrated in Figure 2, the resulting light pattern on the screen will consist of a series of alternately bright and dark vertical bands. These bands are produced by an interference effect between the light beam and the two ultrasonic beams, one portion of the sound waves traveling in the sample and the other portion traveling in the surrounding liquid.

Since the velocity of an ultrasonic wave

in a polymer usually differs from that in the surrounding liquid, the separation of the wave front also differs. The velocity of the wave in the polymer, v_p , is usually greater than the velocity in the water, v_w , and hence the wave fronts are more widely separated in the sample than in the liquid. This is schematically illustrated in Figure 2 where the wave length in the sample is labeled λ_p and that in the water as λ_w . Since these wave lengths differ, there are intervals along the length of the sample where the two waves are in phase; that is, where a compression or rarefaction in the sample matches a compression or rarefaction in the liquid. The interval between these points is labeled "d" on the diagram. Midway between these points, the waves are out of phase and their amplitudes always cancel.

At the positions where the wave fronts are in phase, the optical index of diffraction is appreciably increased or decreased, depending on whether the particular point corresponds to a compression or rarefaction; hence light passing through the tank in one of these regions is deviated away from the pinhead stop and produces a bright band on the screen. At intermediate points, since the sound amplitudes cancel, the refractive index of the system remains unchanged. Light passing through these regions will be undeviated, strike the pinhead stop, and a corresponding dark band will be produced on the screen.

The optical system in this apparatus is arranged to produce an image of a central plane in the ultrasonic tank on the screen with a unit magnification and a photograph of the resulting band pattern is shown in Figure 3. By simultaneously projecting a ruled grid on the screen as shown in the lower portion of the photograph, the separation of the bands, labeled d in Figure 2, can be measured. This quantity can be used to determine the ultrasonic wave velocity in the sample which in turn provides a means of calculating the elastic constants of the polymer at the ultrasonic frequency of the wave.

A mathematical analysis of the two sound waves can be used to show that the separation of the bands in this pattern is related

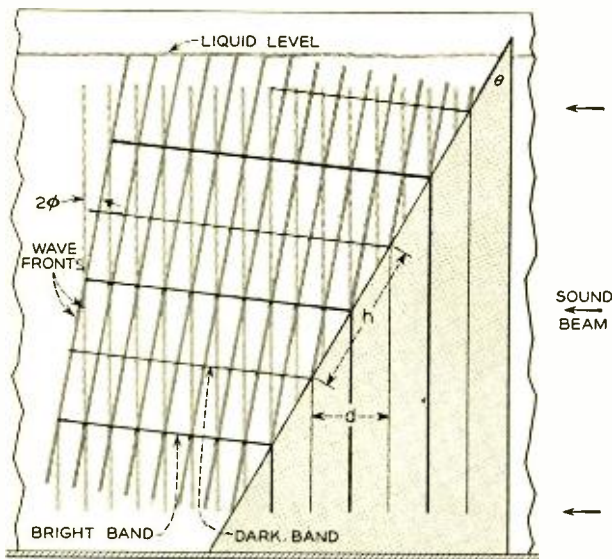

Fig. 5 — Relative positions of the wavefronts in an ultrasonic beam emerging from the sample and those in the beam that passed by the polymer.

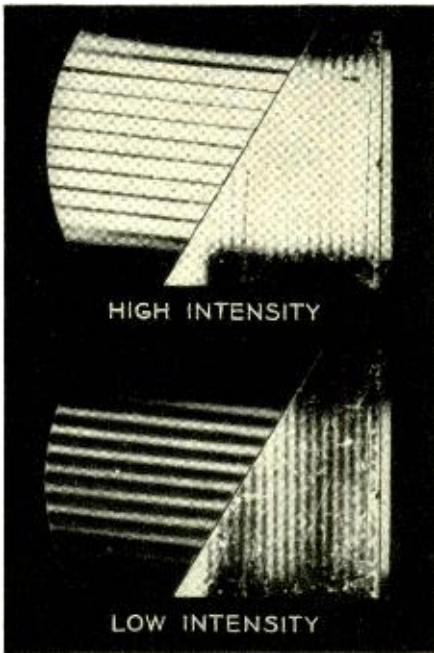

Fig. 6 — Band pattern resulting from the experimental arrangement illustrated in Fig. 4.

to the ultrasonic wave lengths through the simple relation,

$$\frac{1}{d} = \frac{1}{\lambda_w} - \frac{1}{\lambda_p} \quad (1)$$

Also, the frequency, f , of the periodic waves is related to their velocities and wavelengths by

$$f = \frac{v_w}{\lambda_w} = \frac{v_p}{\lambda_p},$$

or $\frac{1}{\lambda_w} = \frac{f}{v_w}$ and $\frac{1}{\lambda_p} = \frac{f}{v_p}$. (2)

Substituting these values of $1/\lambda$ in equation (1) yields the relation

$$\frac{1}{d} = \frac{f}{v_w} - \frac{f}{v_p} \quad (3)$$

Solving equation (3) for v_p yields the working formula for calculating the velocity of the longitudinal ultrasonic wave in the polymer sample

$$v_p = \frac{v_w}{1 - \frac{v_w}{d \cdot f}} \quad (4)$$

In this equation, the ultrasonic velocity in the water, v_w , and the frequency, f , are known. Then by measuring the band separation, d , the desired wave velocity in the polymer can be determined. This split-beam interference method provides a relatively simple way of determining the ultrasonic velocity and hence the elastic constants in a transparent plastic. The method is limited, however, in that the sample must be of sufficiently good optical quality to render the screen pattern clearly visible. This limitation can be overcome, however, by variations of the basic method.

To measure the wave velocity and hence the elastic properties in poorly transparent or even opaque rubbers and plastics, the arrangement illustrated in Figure 4 can be used. In this application, the sample is cut in the form of a 30-degree right-angle prism, thick enough to again intersect about half of the ultrasonic beam. As shown in the diagram, this prism is oriented with its long edge face parallel to the incident ultrasonic wave fronts. If the sample material is sufficiently transparent, a pattern of light and dark vertical bands will appear on the screen within the boundaries of the prism through the same process as previously described. In this case, however, the portion of the ultrasonic beam that traverses the prism material will be refracted

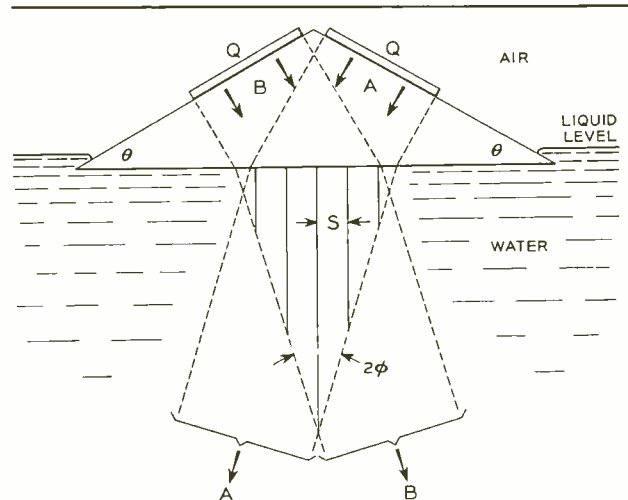

Fig. 7 — Ultrasonic light diffraction apparatus used in measuring transverse wave velocities in polymers.

at the hypotenuse and emerge from the prism material at an angle to the part of the beam confined to the liquid.

Beyond the prism then, the two beams pass through the water inclined to each other by the angle 2ϕ as illustrated in the schematic diagram of Figure 5. If these beams are again regarded as families of parallel planes, constantly moving through the fluid, it is seen that they will intersect at intervals along their paths. At these points of intersection, the two waves are again in phase and light passing through that region will be deviated by the resulting altered index of refraction and hence reach the viewing screen. These points of intersection, indicated in Figure 5, must be regarded as constantly moving through the cell, however, and the resulting transmitted light then traces bright bands on the screen from the hypotenuse of the sample outward into the liquid as illustrated in Figure 4. The band pattern resulting from an application of this method, is shown in the photograph in Figure 6. Once again, the separation of these bands provides a means of determining the ultrasonic wave velocity within the polymer. The separation measured parallel to the hypotenuse of the prism, labeled h , in Figure 5, is related to the previously employed band spacing d , by the formula $d = h \sin \theta$ where θ is the prism angle. For the usual case of $\theta = 30$ degrees, this relation reduces to $d = h/2$. Then, by substituting $h/2$ for d in the working formulas used in the case of a transparent sample (Equation 4), the longitudinal ultrasonic velocity in the polymer can once again be easily determined.

Since this method requires a knowledge of the spacing of only the external bands, it can be used to investigate the elastic properties of completely opaque polymers in which the internal bands would not be visible. The prism used to obtain the photograph in Figure 6 was formed of an optically poor polystyrene. As a result, the internal bands are not particularly clear. The external bands are all that are required, however, and they may be made quite sharp by raising the ultrasonic intensity as shown in the upper portion of Figure 6.

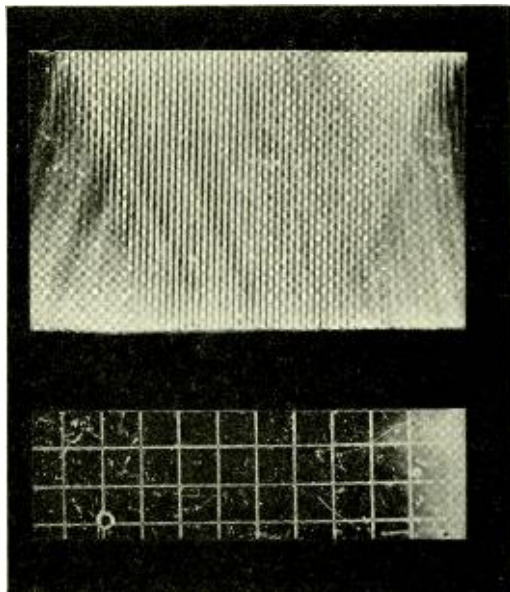

Fig. 8 — Band pattern resulting from the experimental arrangement that is illustrated in Fig. 7.

The two methods described thus far provide a means of measuring the velocity of a longitudinal ultrasonic wave — that is, a wave in which the transmitting particles of the material vibrate parallel to the direction of motion of the wave — in a great variety of polymeric materials. Since the velocity of transverse ultrasonic waves in the material must also be known to calculate the elastic constants, however, a third variation of this split-beam interference method has been devised. These transverse ultrasonic waves, in which particles vibrate at right angles to the direction of motion of the wave, can be generated in a solid by radiators that apply shear type stresses to the material. In this application, a sheet of the sample to be tested is cut in the form of an isosceles triangle. A piezoelectric crystal, labeled q , and cut in such a way that it sets up a shear vibration in the material, is cemented to each of the equal edges of the prism as illustrated in Figure 7. The third edge — the base of the prism — is held in contact with the surface of the water in the ultrasonic cell. Then, when these crystals are simultaneously excited, they each radiate a transverse ultrasonic beam down into the sample material. These transverse

ultrasonic waves exist in the solid, but upon refraction into the liquid they become longitudinal. At the interface between the base of the prism and the water, the two refracted beams pass through each other inclined at an angle 2ϕ as indicated by the beams labeled A and B in the diagram.

Once again, a set of bright bands are formed on the screen by the same process described for the case of an opaque prism. The band pattern resulting from this application of the split-beam interference method, is shown in Figure 8. In this case, the band spacing, S , the prism angle θ and the ultrasonic frequency, f , are used to calculate the transverse wave velocity by the relation,

$$v_T = 2fS \sin \theta .$$

In the typical case of $\theta = 30$ degrees, this reduces to the simple form $v_T = fs$. If the ultrasonic losses are sufficiently low, as they would be if a metal were used as a sample, only one piezoelectric radiator would be required. Partial reflection of the ultrasonic beam at the prism-to-water interface and again at the upper face of the prism would then provide the second interfering beam.

The same equipment can also be used to determine the damping characteristics of a polymer; that is, the rate at which ultra-

sonic waves are attenuated within the material. Such measurements are of great importance, particularly in studying rapidly flexed materials such as those used in vehicle tires, where energy losses may cause excessive heating.

A series of polymers has been investigated by the methods described and it has been found that the longitudinal velocities in plastic polymers are usually intermediate between the low values occurring in liquids and the high values found in metals. In rubbery polymers the velocity is usually very low, approaching that characteristic of a liquid. Among the polymers tested, for example, neoprene rubber exhibited a velocity equal to that of water — 4,920 feet per second at room temperature. In nylon plastic, on the other hand, the velocity was 8,790 feet per second, considerably higher than that in lead. The transverse velocities in plastics are always low, of the order of one half the longitudinal velocity. In rubbers, these transverse velocities are especially low, approaching those characteristic of viscous fluids. These velocity and attenuation measurements can be used, not only to investigate the physical properties of the sample materials, but also to detect variations in the amount of plasticizers and fillers used in a material, and changes in the molecular structure of a polymer.

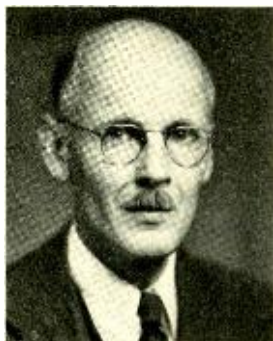

THE AUTHOR: In his twenty-three years with the Laboratories, G. W. WILLARD has been engaged in studies of piezoelectric materials and their applications, especially those related to oscillators. Just prior to and since World War II he has worked mainly on ultrasonic investigations. From these studies have developed improved ultrasonic generators and light valves, as well as new techniques and test methods and new knowledge of propagation media. Mr. Willard received B.A. (1924) and M.A. (1928) degrees from the University of Minnesota.

Adjustable High Q Inductor for Type-O Carrier

R. S. DUNCAN

Transmission Apparatus Development

At the right, Rose Mayorkas adjusts the inductance of the 1509 coil.



Inductors that can be adjusted are old in the art, as are inductors having a high Q, that is, a high ratio of reactance to effective resistance. By means of a ferrite core and a new type of construction a new inductor combines a liberal range of adjustment with an exceptionally high Q. The high resistivity combined with the relatively high permeability of the ferrites makes them particularly valuable in various applications. One such is the Type-O carrier.

Among the features which made the Type-O* carrier system feasible are small wave filters with high discrimination against unwanted frequencies. In turn these filters called for small and accurately adjustable inductors of exceptionally high Q at carrier frequencies up to 200 kc. The requirements were met by developing a ferrite inductor of novel mechanical design (Fig-

Fig. 1 — 1509-type inductor (left) with its components (right).

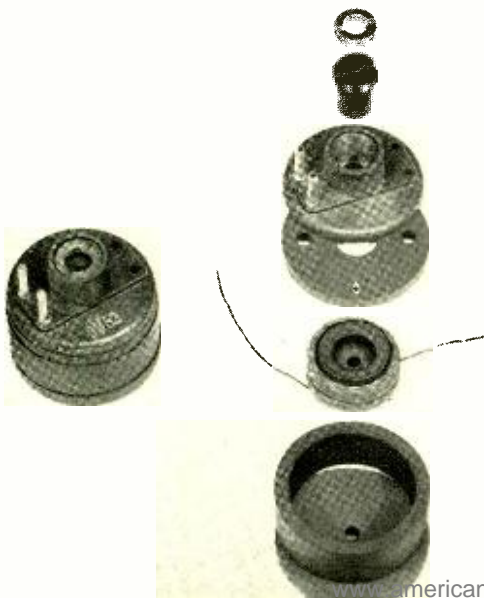

ure 1). This is one of the first applications of ferrite in the telephone system.

The 1509-type inductor has an inductance range from 0.1 to 50 millihenries, a Q of at least 350 from 50 to 180 kc, and is adjustable over a range of plus or minus 11 per cent to an accuracy of 0.01 per cent. As shown in Figure 2 the design involves two windings mounted on a central ferrite core. The winding and central core are enclosed by a ferrite shell which serves both as a mechanical enclosure and a magnetic shield. The air gap between the top of the shell and the central core is shunted by an adjustable core which may be moved up or down by means of a screw in the glass bonded mica terminal plate. The various parts are cemented together under pressure.

Coil losses vary with coil proportions. The proportions were chosen to minimize the dc resistance, a major component of loss in wave filter inductors. Mathematical analysis disclosed that minimum dc resistance is obtained with a central core half

* RECORD, June, 1952, page 252.

† RECORD, May, 1951, page 203.

as wide as the over-all diameter of the coil and, in height, 1.25 times the radius of the coil. Also it was found that with a winding made in a single section, losses at high frequencies were limited by the distributed capacitance. As shown in Figure 3 a superior Q was obtained by constructing the winding in two sections. Alternating current copper losses were minimized by the use of finely stranded wire with each strand insulated.

The design of the mechanical adjustment was shaped by the need for a substantial range of inductance adjustment and for adjustability to very close tolerances. Effective permeability, which controls inductance, varies with the width of the main

adjustable core. This imposes extreme precision on the mechanical parts controlling the motion of the adjustable core.

The provision of a cup-shaped cavity in the central core, with an adjusting core which has a shunting action on the main air gap avoids both faults of butted air gaps. As shown in Curve A of Figure 4, a nearly linear characteristic is obtained and a generous motion of $\frac{1}{8}$ inch is required in order to cover the adjustment range. With this design, it was found that the range of inductance and the linearity of the characteristic are approximately inversely proportional to each other so that a compromise must be made in determining the exact proportions of the core. The 1509-

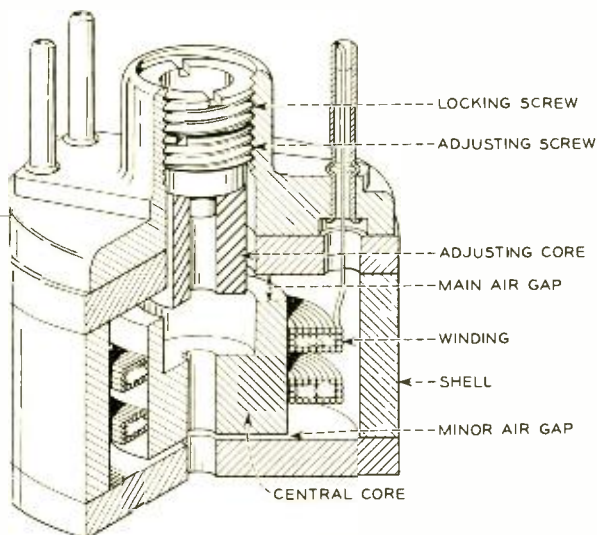

Fig. 2 - Cross section of 1509-type inductor.

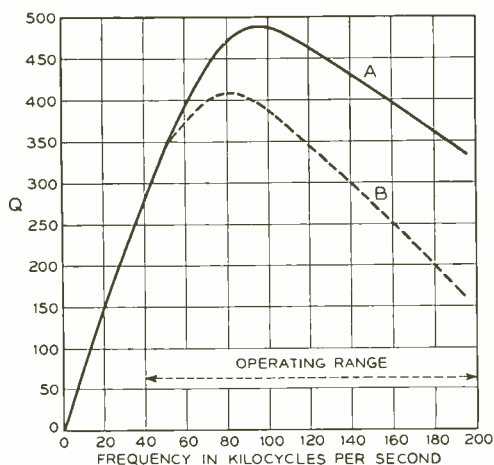

Fig. 3 - Q versus frequency. A - Two-section winding. B - Single-section winding.

air gap (Figure 2). It has been the practice to vary effective permeability by changing the separation between the parallel plane surfaces of the adjusting and central cores. The performance of this "butt" type adjustment is limited in two important ways. As shown in Curve B of Figure 4, the variation of permeability with displacement of the adjustable core, is exponential in character. An inductor using the butt principle is very difficult to adjust precisely on the steep portion of the characteristic. The second limitation is that the range of inductance adjustment corresponds to only a few thousands of an inch of motion of the

type inductor has an adjustment range of 30 per cent which is covered in approximately six and a half turns of the adjusting screw. The inductance is readily set to within plus or minus 0.01 per cent of any value in the nominal range.

The frequency at which maximum Q occurs is determined by the width of the main air gap. The air gap was fixed to give peak Q at approximately 100 kc. Theoretically, Q 's of maximum value are obtained when the main and minor air gaps are equal in width. However, such equality limits the inductance range. To provide the inductance range needed, the minor air gap was

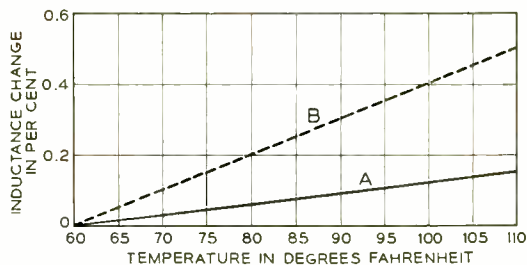
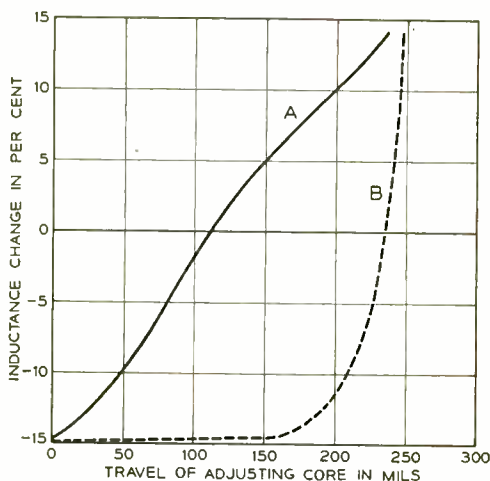

Fig. 5—Inductance-temperature coefficients. A—1509 inductor in which thermal expansion effects compensate for changes in permeability with changes of temperature. B—Uncompensated inductor.

Fig. 4 (at left) — Inductance versus air gap. A—1509-type inductor. B—Inductor with conventional butted air gap.

set at one-tenth the width of the main air gap.

Thermal expansion displacements of the core parts were utilized to compensate for changes in inductance caused by changes in the permeability of the ferrite with temperature. The permeability of ferrite increases as the temperature rises so that the inductance increases. But as the temperature rises the layers of cement between the core parts expand so as to increase the air gaps in the magnetic circuit and thus decrease the inductance. The low inductance-temperature coefficients which

results is shown in Lines A and B of Figure 5.

The Q characteristic of Figure 3 is typical for this type of inductor. Combined with the feature of adjustability the unusually high Q obtained makes this inductor an exceptionally valuable and convenient carrier frequency filter component. The 1509-type inductor provides two and a half times the Q in about one seventh of the volume of the best previously available standard filter coils which, in addition, were not adjustable. It reflects the success of Laboratories development effort to perfect ferrite for the telephone user.



THE AUTHOR: R. S. DUNCAN, a member of the Transmission Development Department, has been engaged in the development of inductors since 1950. Mr. Duncan joined the Laboratories in 1936, after receiving an E.E. degree from Cornell University in 1933, and an S.M. degree in E.E. from Massachusetts Institute of Technology in 1935. He assisted in the design and development of filters, equalizers, and networks before assuming his present responsibilities.

Teletypesetter Equipment in the Bell System

M. N. SMALLEY
Telegraph Development

When a news bureau prepares a news item for distribution, it perforates a tape in "justified" line form, which insures that when the message is printed in a newspaper, both margins will be even. The tape is sent from the bureau over telegraph wires and reproduced at the printing office (a) in identical tape form for use in automatic setting, (b) as typed copy on a page teletypewriter, and (c) as both perforated tape and typed copy.

In 1932 the first Teletypesetter^o equipments were installed in newspaper offices in Newburgh, N. Y. Since then the newspapers throughout the country, singly and in groups, as well as other commercial publishers, have been using Teletypesetter equipments in increasing numbers until now there are several hundred in operation. With the exception of the so-called news magazines, each installation has until recently been owned and operated by the publisher. Late in 1950 the principal news services decided to take advantage of the economies offered by wide scale use of Teletypesetter equipment, with the newspapers continuing to own the typesetting machine but with the Bell System Operating Companies providing a private-line telegraph network for transmitting the copy, and in most cases owning and maintaining the associated transmitting and receiving apparatus, which is similar to that used in teletypewriter service.

The Teletypesetter equipment was designed and developed by the Teletype Cor-

^o Registered Trade Mark.



Fig. 1 — A Linotype machine equipped with a Teletypesetter control unit, evident at the right with the keyboard.

poration, and is fundamentally based on teletypewriter apparatus designs that have been found dependable over long periods of service. The operating unit attaches to either a Linotype or an Intertype composing or line casting machine, the keyboard of which is slightly modified to receive it. The unit attached to a Linotype machine is shown in Figure 1. The composing machine, so equipped, can be operated continuously and automatically at its top-rated capacity from Teletypesetter tape which had been previously prepared in justified line form on a Teletypesetter perforator. Automatic tape operation of the composing machine produces type at a speed of one hundred to two hundred per cent faster than normally obtained from manual operation. One employee is usually assigned to attend several machines, placing fresh tape in the operating units, removing slugs as the galleys are filled, and the like. Manual operation, when desired, is not interfered with

by the presence of the operating unit.

The Teletypesetter perforator, shown in Figure 2, is a motor-driven portable unit equipped with a typewriter-like keyboard, a perforating and counting mechanism, and an end-of-line or justification indicating mechanism. The keyboard and the tape punching mechanism are similar to those used in the 15-type perforator-transmitter in TWX or private wire teletypewriter service, the principal difference being that they are provided with the additional parts required for a 6-unit selection code instead of the 5-unit code ordinarily used for communications, thus making available sixty-four combinations of current and no-current signal elements instead of the thirty-two of the 5-unit code. When two of these sixty-four are used for shift and unshift the remaining sixty-two, available in either lower or upper case position, provide a total of 124 selections which are sufficient for operating all of the levers of the line casting machine used in manual operation.

One of the distinctive features of the Teletypesetter perforator is the arrangement for equalizing the length of the lines — or justifying the lines as it is called in printing parlance. This is accomplished by

the use of an indicating scale and three pointers, evident at the upper right in the photograph. The counting pointer moves from left to right over the upper edge of the scale in amounts proportional to the width of the characters added to the line as different keylevers are operated. These vary from lower case i or l to the letter m, either upper or lower case, which is three times as wide. Wedge-shaped details, called space bands, in the line casting machine provide equal spaces between the words of any one line, from a minimum of 0.037 inch to a maximum of 0.122 inch, and automatically extend the length of the line to an even right-hand margin provided the last word or syllable of the line ends within certain limits, known as the "justification range." This range is indicated by the space between the two justification pointers on the perforator, which move toward the left with each operation of the space bar, one by an amount corresponding to the thick part of the wedge-shaped space bands or the maximum width of the space, the other by an amount corresponding to the thin part of the space bands or the minimum space width. Thus it will be seen that the more words and spaces there



Fig. 2 — The Teletypesetter perforator.

are in a line, the wider the justification range and, accordingly, the greater the opportunity for the operator to add another word or syllable after the counting pointer enters this range. Conversely, with a narrow justification range the addition of a final word or syllable may make the line too long for even the narrowest portions of the space bands while without this word or syllable the line would be too short for even the widest portions. In this case the operator omits the extra letters and lengthens the line by operating the "thin space" key, to insert a "thin space" with each space band in the line and, in extreme cases, between the letters of one or more words of the line.

In the simplest installations the perforated tape is prepared on a Teletypesetter keyboard tape perforator located a short distance from the line casting machine, but preferably in a quiet location free from the noise and confusion of the composing room. As it is punched, the tape can be automatically wound in rolls ready for use in the operating unit of the line casting machine. In the more extensive installations of the large news associations, where copy is edited in a central news bureau for use by a number of newspapers, the tape is prepared at the bureau and, by means of a 20-type transmitter-distributor, the copy is sent by telegraph wire to each paper, where it is received by a 20-type reperforator, which produces a duplicate tape.

As copy is sent from the transmitter-distributor in the main news bureau, a home copy is usually made in page form on a 20-type teletypewriter. In newspaper offices to which copy is sent, it is received simultaneously by the tape reperforator and by a monitoring 20-type teletypewriter. By referring to the typed teletypewriter copy, the local editor can readily determine what material he wishes to delete, to print at once, or to save in the form of perforated tape for future publication—the latter applying especially to weekly papers.

The 20-type transmitter-distributor and the 20-type reperforator are the same as the corresponding 14-type teletypewriter units except that they are arranged to transmit and receive the six-unit selection code. Similarly the 20-type teletypewriter is es-

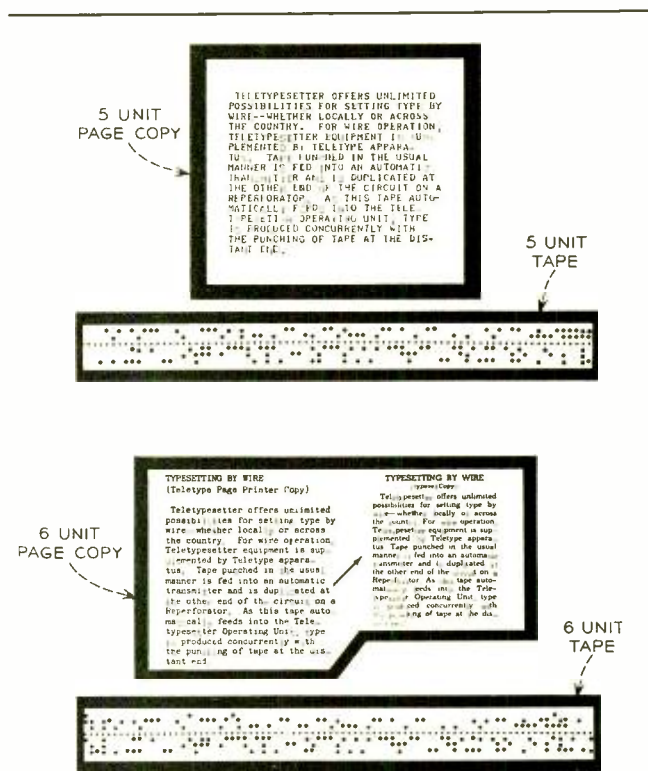

Fig. 3—Five-unit and six-unit code tape, with the perforated message as printed on the No. 15 and No. 20 teletypewriters and the justified typeset copy.

entially a 6-unit 15-type teletypewriter with 43 type bars instead of the 28 available with the 5-unit machine. In addition, the monitoring teletypewriter can be equipped with a contact for remotely cutting the associated reperforator off and on, thus permitting use of the teletypewriter for communication purposes without punching tape. This feature, which was originally developed for the 15-type teletypewriter, required considerable modification to adapt it for Bell System use on the 20 type. The Laboratories cooperated with the Teletype Corporation in this work.

Figure 3 shows the same message in five different forms: in 5-unit code and 6-unit code perforated tape, as printed on the No. 15 and No. 20 teletypewriters, and as justified typeset copy.

To provide for transmitting the six-unit code signals over Bell System circuits, it was necessary to adopt operating speeds that would produce dot-frequencies very

nearly the same as those of the five-unit code signals. This permits the 118C telegraph transmission measuring set^o and the 119C1 telegraph signal distorting set to be used in transmission tests of lines and apparatus. It also permits use of the 143A2 regenerative repeater† without special tuning. For the standard five-unit speeds of sixty and seventy-five words per minute, the corresponding six-unit speeds, from a dot-frequency standpoint, are fifty-three and sixty-six words per minute respectively. The gear ratios for units operating at these speeds as well as the stroboscopic targets for use with governed motors were determined by studies made by the Laboratories.

Material requirements and maintenance

^o RECORD, *December, 1943, page 174.*

† RECORD, *December, 1949, page 436.*

and wiring information for the 20-type apparatus have been prepared in the form of Bell System Practices in the P39 series. These include ordering information for the six-unit perforator tape and for the packages of spare parts which have been made available for the various units.

As of January, 1953, the Long Lines Department had installed for the Associated Press, the International News Service and the United Press Association transmitting and receiving apparatus, including perforators, reperforators, transmitter-distributors and teletypewriters, on forty-three press circuits covering most of the country and involving over 1500 stations. In addition there are thirty-seven stations on eleven press circuits other than those of the three customers mentioned above.

THE AUTHOR: M. N. SMALLEY joined Western Electric Company's Engineering Department in 1920 as a member of the Apparatus Specification Department, and for two years had charge of a group writing specifications. He then became responsible for making arrangements with outside suppliers to manufacture Western Electric apparatus. Since 1925, when the Laboratories was incorporated, Mr. Smalley has been a member of the printing telegraph and teletypewriter group, working with the Teletype Corporation to insure that Bell System requirements are met in the manufactured product.

In 1915 Mr. Smalley was graduated from the University of Michigan with a B.M.E. degree. He worked for Ingersoll Rand from 1915 to 1918.



R. Burns Goes To Stockholm Conference

Representing the American Standards Association, Vice-Admiral George F. Hussey, Jr. has requested Robert Burns of the Chemical and Metallurgical Research Department of the Laboratories to head the United States delegation to the Stockholm meeting of the Technical Committee on Plastics of the International Organization for Standardization (ISO). The delegation will include technical experts from several American companies interested in plastics.

Mr. Burns will also serve as the American member of the Working Group on Standard Laboratory Atmospheres and Conditioning Procedures of Plastics.

The American Standards Association has long been interested in international standardization work, and has participated internationally in the field of plastics since 1950. As the representative of American industry and technology, ASA has accepted the leadership for the Committee on Plastics.



Test Equipment for the TD-2

A. S. MAY

*Transmission
Systems
Development I*

Maintenance is one of the major items that must be taken into consideration in designing, manufacturing, and operating a communication system. Test equipment must be designed and built to handle routine maintenance and to expedite repairs on defective units. Practically all of the equipment of the TD-2 microwave radio relay system has been designed for a specific operation and is highly specialized; test equipment capable of giving adequate information about the radio relay system must of necessity be equally specialized.

There are two principal types of TD-2 radio stations^o—repeater stations and terminal stations. Repeater stations contain a receiver to convert microwave signals to an intermediate frequency for amplification, and a transmitter to convert the amplified signals back to microwaves for transmis-

Operational equipment in the TD-2 microwave radio relay system is highly specialized. Test equipment for this system must not only be equally specialized, but must be compact, efficient, and easy to use.

sion. Terminal stations contain these same elements but they are not connected directly together to form a through circuit. Instead, the receiver is connected to receiving terminal equipment and the transmitter to transmitting terminal equipment. Terminal receivers convert frequency modulated IF signals to amplitude modulated signals for connection to television circuits or to telephone carrier terminal circuits, while a terminal transmitter performs the reverse function.

Since there are many more repeater stations than terminal stations, the test equipment is divided into two sets; a transmitter-receiver test set used at all stations, and a terminal test set used at terminal stations only. The fundamental elements of the transmitter-receiver test set needed to test the repeater equipment are IF and RF sweep oscillators to insert test signals, a meter to measure signal power, and an oscilloscope for observing the test

^o See Bibliography on page 196.

signal as it enters and leaves each component. The terminal test set contains an oscilloscope, FM test set, and a linearity test set.

The first transmitter-receiver test set that was developed for field use was housed in an eight foot high rolling cabinet as shown on the left of Figure 1. The terminal test set is in a sloping front console as shown on the right of Figure 1. These sets are principally an assembly of those laboratory test components and TD-2 system elements that were available at the time field test equipment was first needed.

As field operations of the system progressed, it was found desirable to make im-

provements and simplifications in the test equipment. The large size of the transmitter-receiver test set made it unhandy to wheel about congested radio stations, and the oscilloscope in the sloping front of the terminal test set was difficult to see while adjusting a control in the lower part of an equipment frame. These and other important objections were overcome by redesigning the equipment. Synchronous motors used to drive sweep oscillator capacitors were replaced by diaphragm motors to eliminate bearing maintenance problems. A 402A tube requiring a 1500-volt power supply was replaced by a low-voltage tube. This substitution eliminates both a high-voltage maintenance hazard and the factory servicing required to replace defective 402A tubes and readjust their magnets. Figure 2 shows the greatly improved companion test sets currently being manufactured. The striking features of the new sets are improved appearance, greater utility, superior mobility, and simplified arrangement. Furthermore the cost of manufacture is less than for the older equipment.

The cabinet developed to house the new test sets is only five feet high. For convenience in making power connections, two 115-volt ac power inlets are provided at the back; one at the top and one at the bottom. A switch near the nameplate at the top of the cabinet connects the equipment to the power inlet being used and disconnects the other, so as to avoid danger from exposed terminals. A ventilating fan in the rear of the cabinet circulates filtered air to cool the equipment. Power wiring in the cabinet is enclosed in conduit, and a plug-in strip provides safe and easily accessible receptacles. In some instances more than one station will be maintained by one set of equipment. Because of this, all the units are available in portable cases to aid in transportation, and all operate on commercial ac power.

The top unit of the new transmitter-receiver test set is a specially designed oscilloscope. In order beneath the oscilloscope are an IF sweep oscillator, an RF sweep oscillator, a waveguide panel, and two drawers for detachable parts, cables, and connectors.

Fig. 1 – Old test equipment with transmitter-receiver test set on the left and FM terminal test set on the right.

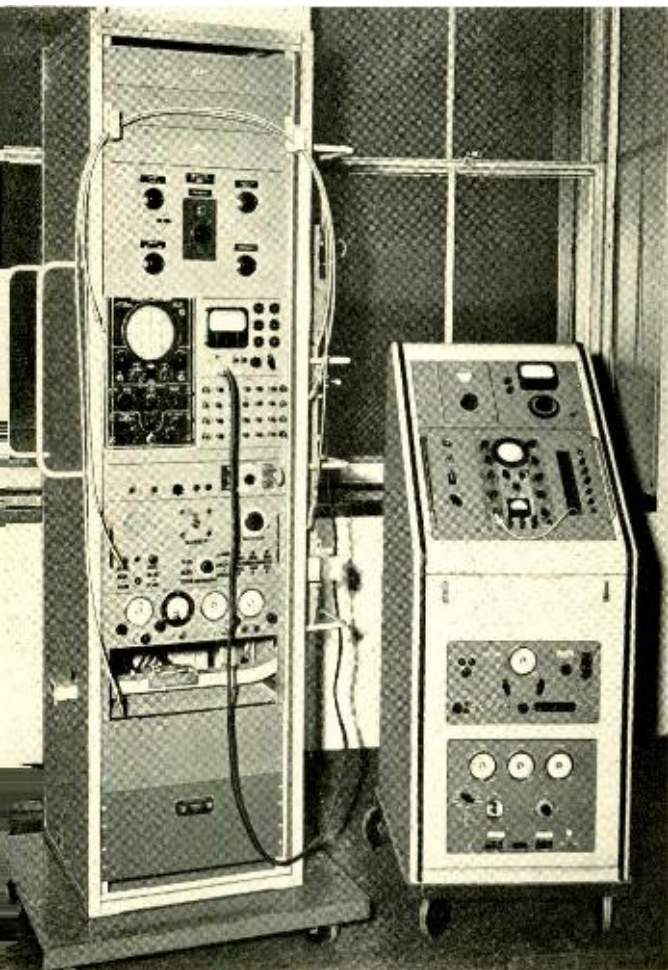

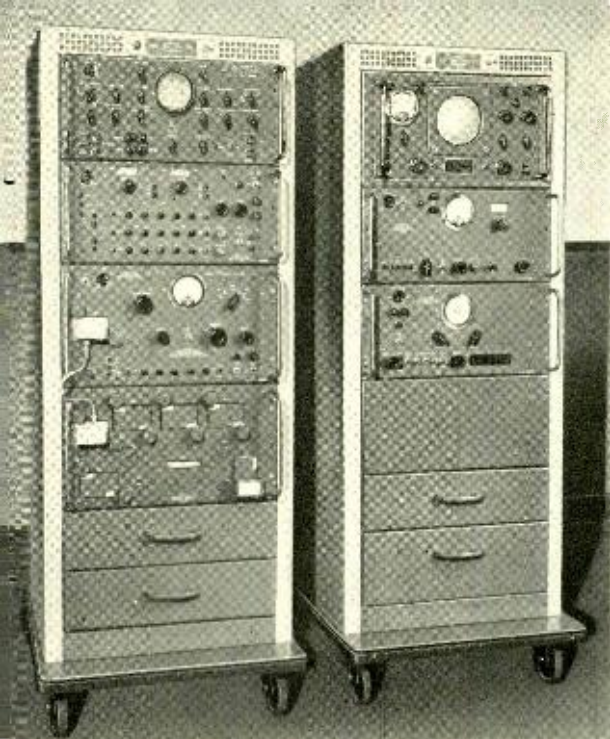

Fig. 2 — New test equipment with transmitter-receiver test set on the left and FM terminal test set on the right.

Incoming microwave signals at radio stations are converted to a 70 mc intermediate frequency for amplification and gain control. Outgoing signals are converted to microwaves for final amplification and then transmitted to the next station. The condition of the IF and RF components is determined by use of the two sweep oscillators and the oscilloscope for visual checking.

For the oscilloscope, a three-inch cathode ray tube with a flat viewing face is used. This flat face gives good definition to the very edge, and is equivalent to the usable portion of the surface of a conventional five-inch curved face tube. Several features not found in ordinary oscilloscopes are included for use in special tests. A pre-amplifier is used to build very low-level signals up to amplitudes large enough to give satisfactory deflections. A 30-cycle reed-operated switch makes it possible to view the detected input and output signals of an amplifier simultaneously for comparison. As the vibrating reed moves from side to side, the input to the oscilloscope is alternately connected to the two signals being investigated and the two pictures appear on the screen in rapid succession. Persistence of the sensi-

tized coating of the screen holds both pictures for a short time after the signals are removed and they appear together.

The IF sweep oscillator is designed to test the performance of the 70-mc amplifiers. It is swept over a range of ± 20 mc with a center frequency of 70 mc by a diaphragm driven capacitor. As may be seen from Figure 3, this is a small unit similar to a loud-speaker without a cone. A movable coil is suspended from a small diaphragm in the field of a permanent magnet. The sweep voltage applied to this coil causes it to move into and out of the field, thus driving the diaphragm. Projecting from this diaphragm is a set of concentric vanes, interleaved with but not touching a similar fixed set of vanes to form a small capacitor. Movement of the diaphragm

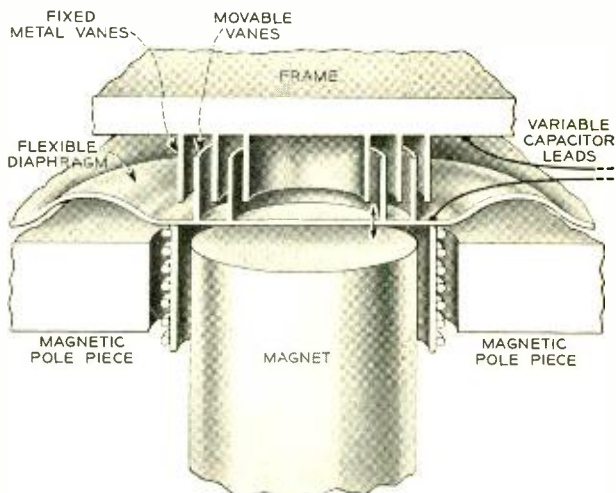

Fig. 3 — Cutaway drawing of diaphragm-driven capacitor used to sweep IF oscillator.

under the influence of the sweep signal changes the area common to the two sets of vanes and thus changes the capacitance. This capacitance in the oscillator circuit sweeps it over the range mentioned. Two outputs are available from the sweep oscillator for test and reference circuits. A third output, proportional to the oscillator frequency, provides horizontal deflection for the oscilloscope and gives a linear frequency display. The three rows of push buttons on the panel are used to adjust cali-

brated attenuators that are inserted in the test circuit. Two IF frequency meters, calibrated from 60 to 80 mc, are included for measuring purposes. These may be inserted into a test circuit to produce markers on the oscilloscope trace for the purpose of frequency identification.

For microwave tests, an RF sweep oscillator is used. It is swept over ± 25 mc by a phase shifter capacitor driven by a diaphragm unit similar to the one described above, but modified for microwave use. Instead of concentric vanes forming a capacitor, a T-shaped rod moves two small metal plates into and out of the feedback path of the oscillator. This oscillator is a 416A tube in a special mounting. The mounting is divided into input and output cavities coupled by the tube, and a waveguide feedback path. As the two small metal plates move into and out of this feedback path, the phase of the feedback voltage is changed and the frequency of the oscillator varies.

The center frequency of the oscillator is adjustable over the range from 3700 to 4200 mc, and the output amplitude is maintained constant at $+23$ dbm by automatic gain

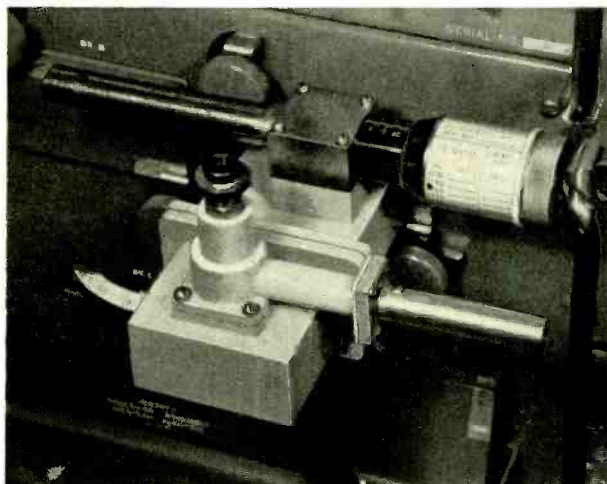
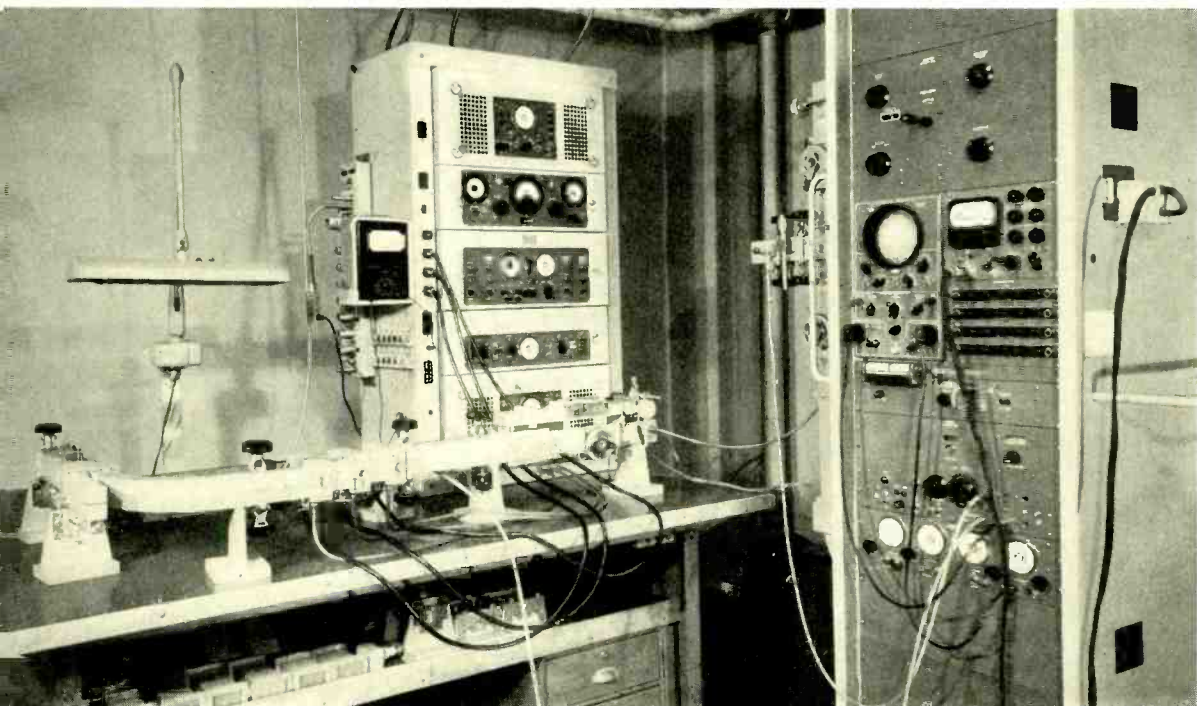

Fig. 4 — Redesigned RF frequency meter showing improved scales and chart.

control. While the RF oscillator in the original test set used a 1500-volt power supply, the voltages in the new unit are comparable to those encountered in ordinary test equipment. Included as part of this unit is a power meter using calibrated crystal detectors for measurement of IF and RF power. Although accurate enough for nor-

Fig. 5 — Maintenance center set up to test and adjust a defective component.



mal test routines, it must be calibrated occasionally with a portable precision power meter kept at maintenance centers. Five push buttons control an attenuator for the simplified IF power meter.

The large amount of waveguide "plumbing" used in the earlier equipment for attenuation has been replaced, in the new unit, by the compact waveguide panel just below the RF oscillator, which is made possible through the use of calibrated directional couplers. These are short pieces of waveguide soldered to the main waveguide at right angles, with holes in the common surfaces of the waveguides where they

placed by broad-band transducers and coaxial cables. The transducers are small shorted sections of waveguide with a coaxial cable projecting into the waveguide as a probe, and so positioned that the cable and waveguide impedances are matched to give good transfer characteristics. The transducers, spare parts, cables, and fittings are stored in the two drawers in the lower part of the cabinet. Also stored here is an RF frequency meter of the absorption type. It is a resonant line with its length determined by a micrometer adjustment. The micrometer has been redesigned with white figures on a black background for better

Fig. 6 - Power meter and frequency calibrator available as auxiliary units.

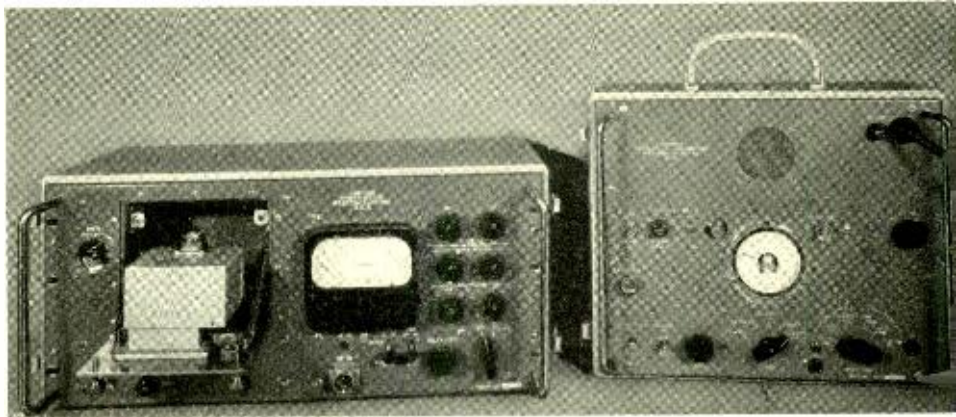

cross. A portion of the signal, the amount determined by the size and spacing of the holes, is passed from the main waveguide into the cross-piece. Signal is fed into the unit from the RF sweep oscillator above it through transducers and a short length of coaxial cable, and may be picked off at any one of the three connections near the top of the panel. These three outputs give fixed attenuations of 22, 35, and 55 db for certain measurements, while the fourth connection in the lower left-hand corner of the panel provides calibrated attenuation variable from 0-20 db. The coverplates for the connectors may be stored in the small rack at lower right when not in use. Special fast-acting clamps are used to hold the plates or detachable waveguide parts in place.

Microwave connections to the bay under test were formerly made using flexible waveguide sections that were bulky and difficult to handle. These have been re-

placed by broad-band transducers and coaxial cables. The transducers are small shorted sections of waveguide with a coaxial cable projecting into the waveguide as a probe, and so positioned that the cable and waveguide impedances are matched to give good transfer characteristics. The transducers, spare parts, cables, and fittings are stored in the two drawers in the lower part of the cabinet. Also stored here is an RF frequency meter of the absorption type. It is a resonant line with its length determined by a micrometer adjustment. The micrometer has been redesigned with white figures on a black background for better

readability, and the calibration is mounted on the handle for convenience, evident in Figure 4. A terminal transmitter changes a video signal to a 70-mc frequency-modulated signal in two steps of modulation. The video signal frequency modulates a microwave oscillator, and the resulting signal is translated to IF by beating with a second microwave oscillator. A terminal receiver at the other end of the circuit changes the 70 mc FM signal back to video. The receiver is similar in function to a commercial broadcast FM receiver, and contains amplifiers, limiters, and a discriminator. The FM terminal test set is used to check and adjust the transmitter and receiver signal conversions existing.

The earlier FM terminal test set consisted of five elements; an oscilloscope, a linearity test set, a signal generator, an electronic switch, and a TD-2 terminal receiver. In the

TD-2 BIBLIOGRAPHY

The TD-2 Radio Relay System, <i>C. E. Clutts</i>	October, 1950 page 442
Repeaters for the TD-2 Radio Relay System, <i>G. R. Frantz</i>	August, 1951, page 356
Terminals for the TD-2 Radio Relay System, <i>J. B. Maggio</i>	July, 1951, page 314
Radio Relay Stations of the TD-2, <i>W. L. Tierney</i>	August, 1952, page 327
Antennas for the TD-2, <i>A. H. Lince</i>	February, 1952, page 49
Power Plants for the TD-2 Radio Relay System, <i>R. R. Gay</i>	March, 1952, page 118
Reserve Power Generators for Unattended Stations	January, 1952, page 30
Sequence Signaling, <i>A. E. Bachelet</i>	December, 1952, page 464
Alarm and Control Features of the TD-2, <i>G. A. Pullis</i>	December, 1952, page 477
TD-2 Radio Switching and Monitoring Equipment, <i>J. A. Word</i>	April, 1952, page 153
Improved Contact Flanges for Waveguides	March, 1953, page 104

newer test set these have been integrated into three simpler units; a new oscilloscope, a modified linearity test set, and a FM test set that includes the functions of the other three elements.

The oscilloscope has a maximum sensitivity of one-quarter volt peak-to-peak per inch of deflection and the wide frequency response required for wave-form monitoring of TV circuits. Two sweep ranges are provided with center frequencies at one-half field frequency (30 cycles) and one-half line frequency (7,875 cycles), and provision is made for calibrating the oscilloscope to measure input signals that are being monitored.

The FM test set permits measurement of the 70 mc FM transmitter and receiver linearity and monitoring of transmitter deviation. Limiters are provided to eliminate amplitude modulation from the input signal. An FM demodulator recovers the

video signal component and a wide range amplifier boosts the video output to a level that may be varied from 0 to ± 6 dbm. For viewing two different signals simultaneously, an electronic switch is included. This does the same job as the reed-operated switch mentioned before, but does it electronically to permit a higher switching rate.

In addition to the FM test set, and used in conjunction with it, a linearity test set is included for testing and adjusting linearity of FM terminal equipment. Measurement may be made and displayed on the oscilloscope of the repeller voltage of the frequency modulated oscillator versus the output frequency of the FM transmitter, of the discriminator linearity, and of the over-all system linearity.

When units or components of the TD-2 system require repair or major adjustments not possible in the field, they are taken to a maintenance center. These centers are



THE AUTHOR: A. S. MAY, a member of Transmission Systems Development I, has since World War II been engaged in the design of microwave radio relay equipment for telephone and television. Mr. May was graduated from West Virginia University in 1939 with a B.S. degree in E.E. He then joined the Laboratories and for two years participated in trial installations of automatic Teletype switching systems. During World War II he designed radar equipment for the armed services.

conveniently located to handle a group of radio stations, and may be part of a normally attended station or may be set up just for TD-2 maintenance purposes. Test equipment here includes a transmitter-receiver test set and a specially designed test bench incorporating TD-2 components. Figure 5 shows this bench set up for a test and repair job on a defective unit. Use of TD-2 control units in the bench supported cabinet and the power plug-in connecting strip in the left front edge of the cabinet permits

the repairman to work on the defective unit while the system is connected for normal operation.

Two auxiliary units are available for occasional use (see Figure 6). These are a frequency calibrator for adjusting transmitter frequency, and an accurate power meter for precise measurements at maintenance centers. Both of these units are required for occasional calibration checks at radio stations, and are portable to allow use at more than one station.

Patents Issued to Members of Bell Telephone Laboratories During February

- Albano, V. J. — *Method of Forming a Point at the End of a Wire* — 2,628,936.
- Anderson, A. E. and Sears, R. W. — *Bandwidth Reduction System* — 2,629,771.
- Anderson, F. A., Blattner, D. G., and Miller, V. F. — *Swaging Pliers for Electrical Connections* — 2,627,769.
- Blattner, D. G., see F. A. Anderson.
- Dahlbom, C. A. and Weaver, A. — *Speech Transmission System* — 2,629,017.
- Edwards, P. G. — *Unbalanced-to-Ground Two-to-Four Wire Connection* — 2,629,024.
- Feldman, C. B. II. — *Radio Repeater Having a Pulse Regenerator* — 2,627,574.
- Gooderham, J. W. — *Automatic Toll-Ticketing System* — 2,629,016.
- Graham, R. E. — *Television System Having Reduced Transmission Bandwidth* — 2,629,010.
- Graham, R. F. — *Television System Having Reduced Transmission Bandwidth* — 2,629,011.
- Hall, N. I. and Warren, C. A. — *Phase Adjuster* — 2,629,773.
- Hopkins, H. F. — *Telephone Circuit* — 2,629,783.
- King, J. H. — *Ventilator for Telephone Booths* — 2,628,550.
- Koenig, W., Jr. — *Signal Transmission System* — 2,629,779.
- McKim, B. — *Semiautomatic Telephone Switching System Arranged for Selective AC or DC Key Pulsing* — 2,628,283.
- Meacham, L. A. and Michaels, S. E. — *Semiconductor Translating Device* — 2,627,575.
- Michaels, S. E., see L. A. Meacham.
- Miller, R. L. — *Determination of Pitch Frequency of Complex Wave* — 2,627,541.
- Miller, V. F., see F. A. Anderson.
- Oliver, B. M. — *Amplifier Circuit Having a Reactive Load* — 2,629,006.
- Pearson, G. L. — *Semiconductor Signal Translating Device* — 2,629,800.
- Peterson, I. C. — *Transversal Electric Wave Filter* — 2,629,841.
- Potter, J. A. — *Voltage and Current Regulation* — 2,628,340.
- Potter, R. K. — *Visual Representation of Complex Waves* — 2,629,778.
- Ring, D. H. — *Reduction of Phase Distortion* — 2,629,772.
- Ring, D. H. — *Reduction of Phase Distortion* — 2,629,782.
- Robertson, D. D. — *Coordinate Selecting and Lock-Out Circuit in Interpolated Speech Receiving System* — 2,629,020.
- Robertson, D. D. and Wurmsler, A. V. — *Coordinate Switching and Lock-Out Circuit in Interpolated Speech Receiving System* — 2,629,021.
- Rose, C. F. — *Adjustable Impedance Transformer* — 2,627,550.
- Sears, R. W., see A. E. Anderson.
- Sparks, M. — *Method of Making Semiconductive Translating Devices* — 2,629,672.
- Trent, R. L. — *Transistor Trigger Circuits* — 2,629,833.
- Trent, R. L. — *Gate and Trigger Circuits Employing Transistors* — 2,629,834.
- Townsend, M. A. — *Constant Voltage Glow Discharge Control Device* — 2,629,842.
- Waddell, J. H. — *Optical Projecting Comparator* — 2,627,780.
- Warren, C. A., see N. I. Hall.
- Weaver, A., see C. A. Dahlbom.
- Wurmsler, A. V., see D. D. Robertson.

W. H. Martin Is Guest Professor

As the fourth in a series of ten "guest professors," W. H. Martin, Vice President of the Laboratories, explained the functions and operating procedures of Bell Telephone Laboratories to a group of University of California students. Mr. Martin's talk on March 25 was one of the series of lectures presented to the students in Business Administration at the University by the Pacific Telephone and Telegraph Company.

Each term the University chooses a major industrial organization to participate in a course on Management Problems and Policies, and the present course is designed to acquaint the students with the problems and policies of Pacific Telephone and the Bell System. Since the Laboratories, as an integral part of the Bell System, designs and develops apparatus and equipment for the System, Mr. Martin was requested by the Pacific Company to be Bell Telephone Laboratories' representative in the Bell System series.

Mr. Martin pointed out that "The Laboratories . . . responsibility is to develop new and improved facilities for the operating companies and to determine the designs and requirements which are to be used by Western in manufacturing and procuring the equipment and materials required . . . for rendering communications services." He outlined the general pattern of Laboratories activities, explained the development of the 500-type telephone set as an example of the development process, and then summarized the salient features of this development process in the Laboratories. These include systems engineering for selecting projects and setting objectives and requirements; development of a device as part of an over-all system; integration of requirements and economics of manufacture and service into design during development; continual systematic quantitative causal analysis: conservation of time by preparing for manufacture during development; preappraisal of suitability for service; stress on service reliability; and design for maximum customer service value.

The Record Gets New Editor

With this issue of the RECORD readers will note from the Contents Page that Julian D. Tebo succeeds Philip C. Jones as Editor. Mr. Jones retired under the Bell System Retirement Age Rule on April 30.

Mr. Jones graduated from the Massachusetts Institute of Technology in 1912, and spent a number of years in consulting engineering and as engineer in charge of a large rubber company's electrical installations. Coming to Bell Telephone Laboratories in 1927, he became Science Editor of the RECORD, and upon the retirement of Paul B. Findley in 1952, he became the Editor. Since 1949, he has also been Editor of The Bell System Technical Journal.

Mr. Tebo graduated from Johns Hopkins University in 1924 with a B.E. degree in Electrical Engineering and in 1928 received the Dr. Eng. degree from the same institution. Coming directly to the Laboratories, his first assignments were on relay design particularly as applied to coordination between telephone lines and power circuits. He then became engaged in crossbar switch development, designing the electromagnets and establishing requirements for crossbar switches and multicontact relays. In 1938, he was put in charge of the machine switching laboratory. During World War II he was concerned with the design and manufacture of radar and sonar equipment for use by the Armed Forces. Following the war he returned to machine switching, and in 1949, became Science Editor of the RECORD. He will also succeed Mr. Jones as Editor of The Bell System Technical Journal.

Deal-Holmdel Colloquium

The Deal-Holmdel Colloquium held its seventh meeting of the season at Holmdel on April 3. Speaker at the meeting was W. J. Merz, who spoke on *Ferro-Electric Domains*. This subject has aroused widespread interest recently since ferro-electric properties are now being used, at least experimentally, as the basis of new electronic calculating machines.

Automatic Teletype System

American Airlines had a problem: how to increase the efficiency of their private Teletype system; the Bell System came up with the answer. A new, completely automatic, Teletype system connects the airline's 70 stations across the nation. The previous network along American's routes handled an average of 571,000 Teletype messages per month, but not most efficiently. The new 81-D-1 system, developed by the Laboratories, not only handles this number of messages with ease, but eliminates virtually all the "bugs" previously present.

Messages were formerly recorded at each office on a circuit, then discarded if addressed to another office; the new system sends a copy only to the office or offices addressed, resulting in a saving of about \$2,500 per month in paper alone. Messages are relayed automatically at one of three switching centers, in New York, Chicago, and Fort Worth, and operators no longer lose time waiting for their turn in the transmitting sequence, since transmission is automatic. Priority messages, such as air-to-ground contacts, are automatically handled first, then routine messages are picked up and properly distributed by the system. Incorrectly addressed messages, and messages to a machine temporarily out of order, are picked off by an intercept machine and held until the address or the defective machine is corrected. Addresses on air-to-ground contacts may even be added to a message by simply pushing a pre-set button.



One operator at this switching center control console has American Airlines' complete Teletype services at her fingertips. Traffic may be diverted to intercept machines in the switching center when a station is out of order, and alarm bells and lights quickly pinpoint the malfunctioning station.



Intercept machines used to hold information not immediately deliverable as a result of maintenance or repairs at the addressed station.

Part of the equipment necessary for the operation of the 81-D-1 automatic Teletype system. Two other switching centers, in Chicago and Fort Worth, plus this one in New York, control the entire system.





Zworykin Television Award

Presented To Frank Gray

Frank Gray, who retired from Bell Telephone Laboratories in September, 1952, was the second recipient of the annual Vladimir K. Zworykin Award to a member of the Institute of Radio Engineers. The presentation, made at the Waldorf-Astoria Hotel as part of the activities of the Convention of I.R.E., held in March, 1953, was for Dr. Gray's important contribution to electronic television. This important invention permits two different television signals to be transmitted simultaneously within a frequency range normally sufficient for only one signal. Patent 1,769,920 based on this invention was issued July 8, 1930.

A compatible color television system is now being developed around this principle, as a joint effort of many interested groups. A "luminance" signal will transmit information regarding light values in a television picture, and may be received on ordinary black-and-white receivers with no changes. A second, or "chrominance," signal carries information regarding colors in the

picture, and Dr. Gray's invention permits this also to be transmitted without enlarging the frequency range of communications channels.

This award climaxes about thirty years of work on television for Dr. Gray, but is for only one of his many important contributions. In the summer of 1925, Frank Gray and his assistant, J. R. Hefele, were experimenting with television in the then newly organized Bell Telephone Laboratories. Their experimental set-up was arranged as was customary at that time, with a photoelectric cell excited by light reflected from the subject through holes in a mechanical (Nipkow) scanning disc. Many stages of amplification were needed to transmit signals any appreciable distance.

One day Mr. Gray reversed the usual arrangement of lights and photoelectric cell, and, as he phrased it, "turned things upside down." A bank of photoelectric cells collected light reflected from the subject while pencils of light through the rotating disc rapidly scanned the subject. This "upside down" method of scanning actually "turned things upside down" in the television field, for it brought about the increased signal required for longer distances, and was the first flying-spot scanner.

Frank Gray at the rear and his assistant, J. R. Hefele, in the foreground with an early mechanical scanning system.

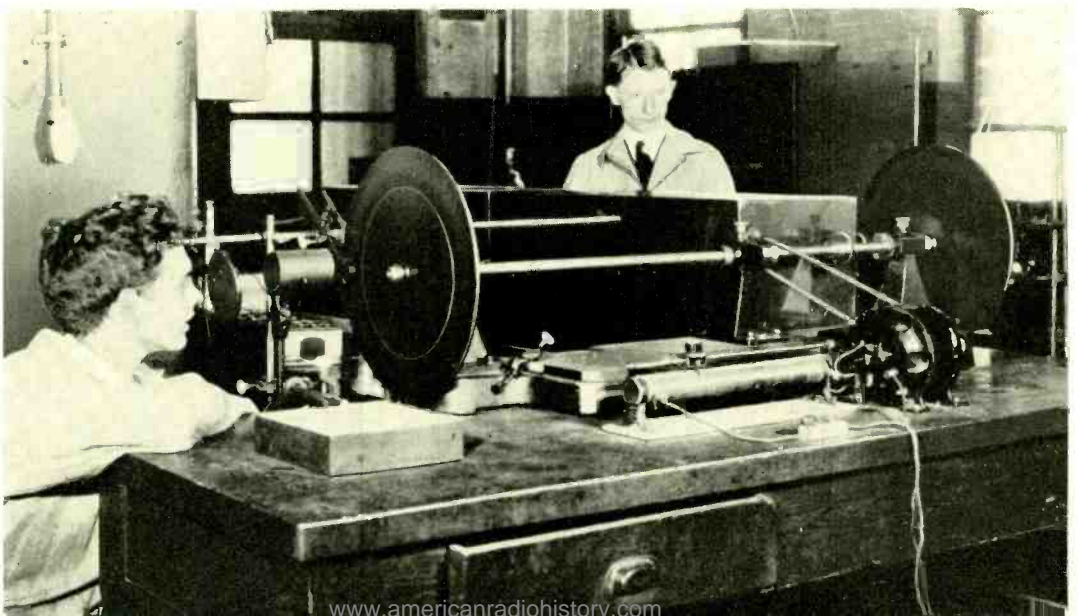

On April 7, 1927, a large group in New York City saw and spoke with the Honorable Herbert Hoover while he sat in a studio in Washington, D. C.; this Bell System demonstration using Gray's system of scanning was the first transmission of live television programs in the United States. The signals traveled from Washington to New York over existing open wire lines; in a second program immediately following, the signals originated at Whippany and were transmitted to New York via radio.

Among his other activities in the television field were his early use of a cathode-

receiving his Ph.D and becoming an Assistant Professor of Physics. Except for a short time during World War I, his entire career was spent with the Laboratories.

American Physical Society

Bell Telephone Laboratories was well represented at the North Carolina Meeting of the American Physical Society at Durham and Chapel Hill, March 26 to 28. The Secretary of the Society for 1953 is K. K. Darrow, and William Shockley is a member of the Council. Mr. Shockley presided at one Section, was a member of the Symposium on Semiconductors, and was one of the after-dinner speakers at the banquet.

W. T. Read was a member of the Symposium on Plasticity and Dislocations, and J. Hobstetter was a member of the Symposium on Nucleation Theory. Submitted papers were presented by W. Shockley, G. H. Wannier, T. S. Benedict, P. Debye, M. B. Prince, H. W. Lewis, F. L. Vogel, W. G. Pfann, H. E. Corey, E. E. Thomas, P. A. Wolff, R. C. Fletcher, W. L. Brown, S. Machlup, M. Tanenbaum, and G. L. Pearson. The complete listing of Talks by Members of the Laboratories on page 198 of this issue includes those given at the North Carolina Meeting.

N Carrier Gets Program Service

Tests of type-N carrier circuits between Presque Isle and Bangor, Maine, were recently carried out for Schedule A Program service. Network broadcasting utilizing Schedule A Program covers frequencies up to five kilocycles, and special adaptations had to be made to the type-N system for the tests. The data collected during the tests will be used in an installation between Santa Ana and Los Angeles, scheduled for completion in time for the Boy Scout Jamboree in June.

R. L. Case, C. I. L. Cronburg, G. J. Nixon, L. Pedersen, and A. V. Wurmser of Transmission Systems Development and B. C. Griffith and D. T. Osgood of the Transmission Engineering Department joined representatives of the AT&T and the New England Telephone Company in conducting the tests.

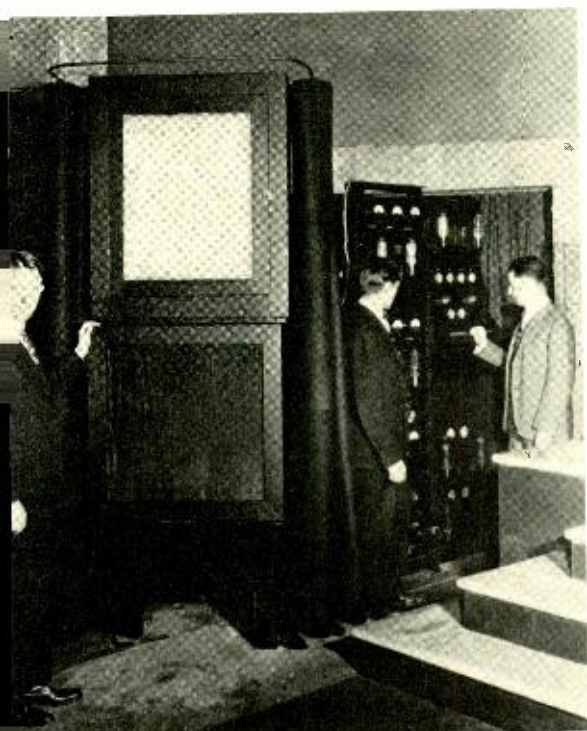

Equipment used in the Bell System demonstration of live programs in 1927. Mr. Gray stands alongside the loudspeaker, with the picture surface immediately above it. Examining a portion of the equipment are W. S. Bishop, with his back to the camera, and E. Peterson.

ray tube similar to those in present-day receivers, and he was also one of the pioneers in the development of interlaced scanning.

On retiring from the Laboratories, Mr. Gray returned to his native town of Alpine, Indiana. He studied at Purdue University and later at the University of Wisconsin,

Talks by Members of the Laboratories

During the month of March, a number of Laboratories people gave talks before professional and educational groups. Following is a list of the speakers, titles, and place of presentation.

AMERICAN PHYSICAL SOCIETY, NORTH CAROLINA MEETING

Benedict, T. S. and W. Shockley, Carrier Contribution to the Dielectric Constant of Germanium.

Brown, W. L., and R. C. Fletcher, Annealing of Bombardment Damage in Germanium: Experimental.

Brown, W. L., see R. C. Fletcher.

Corey, H. E., see F. L. Vogel.

Debye, P. P.; Hall Effect and Conductivity of Germanium Containing Arsenic or Gallium as Impurities.

Fletcher, R. C., W. L. Brown and S. Machlup, Annealing of Bombardment Damage in Germanium: Theoretical.

Fletcher, R. C., see W. L. Brown.

Hobstetter, J. N., Nucleation of Solid-Solid Transistors.

Lewis, H. W., Search for the Hall Effect in a Superconductor.

Machlup, S., Nyquist and Einstein Relations Derived from a Scattering Model.

Machlup, Stefan, see W. L. Brown.

Pearson, G. L., see M. Tanenbaum.

Pfann, W. G., see F. L. Vogel.

Prince, M. B., Temperature Variation of Drift Mobilities of Minority Carriers in Semiconductors.

Read, W. T., Recent Advances in Dislocation Theory.

Shockley, W., Electrons and Holes in Electric and Magnetic Fields.

Shockley, W., Dislocations and Edge States in the Diamond Crystal Structure.

Shockley, W., see T. S. Benedict.

Tanenbaum, M. and G. L. Pearson, The Magneto-Resistance in InSb.

Thomas, E. E., see F. L. Vogel.

Vogel, F. L., W. G. Pfann, H. E. Corey and E. E. Thomas, Dislocations in Low Angle Boundaries in Germanium Single Crystals.

Wannier, G. H., Radiationless Trapping of Charge Carrier in Solids.

Wolff, P. A., Plasma Waves in Metals.

I. R. E. NATIONAL CONVENTION

Alsberg, D. A., Transistor Metrology.

Evans, H. W., Crosstalk in Radio Systems Caused by Foreground Reflections.

Fewer, D. R., Transistor Static Characteristics Obtained by Pulse Techniques.

Follingstad, H. G., A Transistor Alpha Sweeper.

Glaser, J. L., Performance of Space and Frequency Diversity Receiving Systems. (Co-author with M. Acker and R. E. Lacy, Signal Corps Engineering Laboratories, Fort Monmouth, N. J.)

Kelly, M. J., Research and Development Problems of Engineering Management in the Electronic Industry.

Kummer, O., Wideband Wave Analyzer.

Mertz, P., and K. W. Pfeleger, Effect of Hits in Telephotography.

Pfeleger, K. W., see P. Mertz.

Ryder, R. M. and W. R. Sittner, Reliability of Transistors.

Scanlon, J. J., Life and Reliability Experience with Transistors in a High-Speed Digital Computer.

Sittner, W. R., see R. M. Ryder.

Stansel, F. R., The Grounded-Collector Transistor Amplifier at Carrier Frequencies.

Valdez, L. B., Characteristics of M-1768 Transistor.

Wallace, R. L., Jr., Transistor Amplifiers.

OTHER TALKS

Allison, H. W., see G. E. Moore.

Anderson, O. L., and D. A. Stuart, Statistical Theories as Applied to the Glossy State, Symposium on Glass Technology, American Chemical Society, Los Angeles.

Andrews, F. T., Memory in Telephone Switching Systems, Seminar Electrical Engineering, Penn State College.

Beach, A. L., see W. G. Guldner.

Becker, J. A., Field Emission from Oxygen on

Tungsten: How It Varies with Amount Adsorbed on Various Crystal Planes, M.I.T. Conference on Physical Electronics, Cambridge, Mass.

Bogert, B. P., The Physics of Music and Hearing, Society of Sigma Xi, Polytechnic Institute of Brooklyn.

Darnell, P. S., I. R. E. Pittsburgh Section, Miniaturized Components and Their Applications in Transistor Electronics, Pittsburgh.

Finch, L. R., Circuit Applications of Transistors, A. I. E. E. and I. R. E. Sections, Ames, Iowa, Cedar Rapids, Iowa, Phoenix, Ariz., Denver, Colo., and A. I. E. E. Student Sections, Iowa City, Iowa, and Boulder, Colo.

Frost, G. R., Thinking Machine, Park Avenue Hospital, New York City.

Galt, J. K., Domain Wall Motion in Ferrite Single Crystals, University of Wisconsin, Madison, Wis., and Rensselaer Polytechnic Institute, Troy, N. Y.

Guldner, W. G., and Beach, A. L., A Gaseometric Method for the Determination of Hydrogen in Carbon, Analytical Conference on Applied Spectroscopy, Pittsburgh.

Hamming, R. W., Classification of the Various Kinds of Computers Now in Existence, Educational Committee of Power and Industrial Division, A. I. E. E., New York.

Hannay, N. B., The Formation of Negative Ions of Sulfur Hexafluoride, Conference Section on Analytical Chemistry and Applied Spectroscopy, A. S. T. M., Pittsburgh.

Harris, J. R., Nonstable and Astable Transistor Circuits, A. I. E. E. and I. R. E. Sections, Garden City, N. Y.

Hayward, W. S., The Reliability of Telephone Traffic Switch Counts, Rutgers University, New Brunswick, N. J.

Hogan, C. L., The Ferromagnetic Faraday Effect at Microwave Frequencies, Physics Colloquium of Harvard University, Cambridge, Mass.

Hussey, L. W., Pulse Circuit Techniques, I. R. E., Long Island Section.

Legg, V. E., Magnetic Materials and Their Application, American Society for Metals, Schenectady, N. Y.

Linville, J. G., Linear Negative Impedance Circuits, I. R. E., Long Island Subsection, Garden City, N. Y.

Lovell, C. A., The Switching Automaton, Engineering Faculty and Graduate Students of University of California, Berkeley, Calif.

Lundberg, J. L., Thermodynamics of High Polymer Solutions: The System Polystyrene-Toluene Experimental Results, American Chemical Society, Los Angeles.

Machlup, S., A Statistical Interpretation of the

Dissipation Function, U. S. Bureau of Mines, Pittsburgh.

Martin, W. H., Bell Laboratories, Business Administration Students, University of California, Berkeley, Calif. (See page 194.)

McNally, J. O., Tube Reliability As It Applies to the Telephone Field, I. R. E., North New Jersey Subsection.

Moore, G. E., and H. W. Allison, The Adsorption Mechanism for Sr and for Ba on Tungsten, M. I. T. Conference on Physical Electronics, Cambridge, Mass.

Pietenpol, W. J., Transistors Today, A. I. E. E., Northeastern Section, Michigan.

Raisbeck, G., n-p-n Transistors, I. R. E. and A. I. E. E. Sections, Polytechnic Institute, Brooklyn, N. Y.

Read, W. T., Dislocation Theory, University of Virginia, Charlottesville, Va.

Riesz, R. R., How Far Should We Go in Automatization? Panel discussion on Human Engineering and Psychophysiology, Research and Development Board at Rand Corporation, Santa Monica, Calif.

Romanow, F. F., Career Possibilities at Bell Telephone Laboratories, Junior Class at Brooklyn Polytechnic Institute, Brooklyn.

Ryder, R. M. and W. R. Sittner, Reliability of Transistors, I. R. E. Section, New York City.

Ryder, R. M., Solid State Device Operations — Particularly as Applied to Transistors, Physics Colloquium, University of Tenn., Knoxville, Sigma Xi Meeting, Knoxville, and Sigma Xi Meeting, Virginia Polytechnic Institute, Blacksburg, Va.

Schimpf, L. G., Transistor Applications, U. S. Naval Air Development Center, Aeronautical Electronics and Electrical Laboratory, Johnsville, Pa.

Shockley, W., The Physics of Music and Hearing, Sigma Xi Meeting, Brooklyn Polytechnic Institute, Brooklyn, N. Y.

Sittner, W. R., see R. M. Ryder.

Sparks, M., Fundamentals of Transistor Electronics, A. I. E. E., New Jersey Division, Newark, N. J.

Stuart, D. A., see O. L. Anderson.

Terry, M. E., Sensory Differences and Quality Control, Raritan Valley Subsection of American Society for Quality Control, Rutgers University, New Brunswick, N. J.

Wilkinson, R. I., Operation Research, American Society for Quality Control, New York City.

Winslow, F. H., Odd Electrons in Macromolecules, American Chemical Society, Polymer Group, Newark, and Polymer Carbon, Chemistry Seminar, Rutgers University, New Brunswick, N. J.

I.R.E. Regional Conference

J. W. McRae, Vice President of the Laboratories and President of the Institute of Radio Engineers, was the featured speaker at the banquet of the 1953 I.R.E. Seventh Regional Conference held recently at the University of New Mexico. He presented a paper entitled, *The Radio Engineer Looks Ahead*.

R. C. Newhouse, Military Development Engineer at Whippany, spoke at one of the conference sessions on *System Concepts in Military Weapons*.

More than 500 engineers and technicians attended the two-day meeting.

Dr. Shockley Receives Certificate of Appreciation

A Certificate of Appreciation was awarded to William Shockley by the Department of the Army for his "outstanding contributions to the Army and to the National Defense effort" while serving on the Army

Scientific Advisory Panel. Accompanying the citation was a letter in which the Secretary of the Army expressed his personal thanks to Dr. Shockley for "selfless devotion of time and effort and for the real contributions you have made to our defense capabilities."

Dr. Urey Visits Laboratories

Harold C. Urey, discoverer of heavy water and a Nobel prize winner in Chemistry, spoke at one of the recent Research Department Colloquia on *The Chemistry of Meteorites and Its Significance in Cosmology*. In his talk Dr. Urey mentioned that the surfaces of the earth and other planets appear to have been produced at much lower temperatures than has previously been believed. Evidence to support this view seems to lie in the role of water in the formation of the earth's crust. While at Murray Hill, Dr. Urey visited several of the laboratories there.

Papers Published by Members of the Laboratories

Following is a list of the authors, titles, and place of publication of recent papers published by members of the Laboratories:

Ahearn, A. J., and N. B. Hannay, Formation of Negative Ions of Sulphur Hexafluoride, *J. Chem. Phys.*, **21**, pp. 119-124, Jan., 1953.

Drvestep, J. J., and A. W. Lebert, Standardization of Rigid Coaxial Transmission Lines, *Tele-Tech*, **12**, pp. 78-79, Feb., 1953.

Felker, J. H., Typical Block Diagrams for a Transistor Digital Computer, *Elec. Eng.*, **71**, pp. 1103-1108, Dec., 1952 and *A.I.E.E. Trans.*, **71**, pp. 175-182, 1952.

Frayne, J. G. and J. P. Livadary, Dual Photomagnetic Intermediate Studio Reporting, *J. S.M.P.T.E.*, **59**, pp. 388-397, Nov., 1952.

Hagstrum, H. D., Electron Ejection from Mo by He⁺, He⁺⁺, and He₂⁺, *Phys. Rev.*, **89**, pp. 244-255, Jan. 1, 1953.

Hannay, N. B., see A. J. Ahearn.

Heidenreich, R. D., Methods in Electron Microscopy of Solids, *Rev. Sci. Instr.*, **23**, pp. 583-594, Nov., 1952.

Jakes, W. C., Jr., Theoretical Study of an Antenna-Reflector Problem, *I.R.E., Proc.*, **41**, pp. 272-274, Feb., 1953.

Lebert, A. W., see J. J. Drvestep.

Livadary, J. P., see J. G. Frayne.

Luke, C. L., Photometric Determination of Silicon in Ferrous, Ferromagnetic, Nickel, and Copper Alloys - A Molybdenum Blue Method, *Anal. Chem.*, **25**, pp. 148-151, Jan., 1952.

MacWilliams, W. H., Jr., Computers - Past, Present and Future, *Elec. Eng.*, **72**, pp. 116-121, Feb., 1953.

Mumford, W. W., Optimum Piston Position for Wide-Band Coaxial-to-Waveguide Transducers, *I.R.E., Proc.*, **41**, pp. 256-261, Feb., 1953.

Olsen, K. M., see W. G. Pfann.

Peterson, G. E., Information-Bearing Elements of Speech, *J. Acoust. Soc. Am.*, **24**, pp. 629-637, Nov., 1952.

Pfann, W. G., and K. M. Olsen, Purification and Prevention of Segregation in Single Crystals of Germanium, Letter to the Editor, *Phys. Rev.*, **89**, pp. 322-323, Jan. 1, 1953.

Rice, S. O., Statistical Fluctuations of Radio Field Strength Far Beyond the Horizon, *I.R.E., Proc.*, **41**, pp. 274-281, Feb., 1953.