

5 SEP '61

August 1961

Bell Laboratories

RECORD

Electronic Memory Devices

Measuring the Sky's Electrical Noise

Surface-to-Air Data Communications

The Art of Counting Calls

A Statistical Ammeter

NAVY ELECTRONICS
LIBRARY
LABORATORY

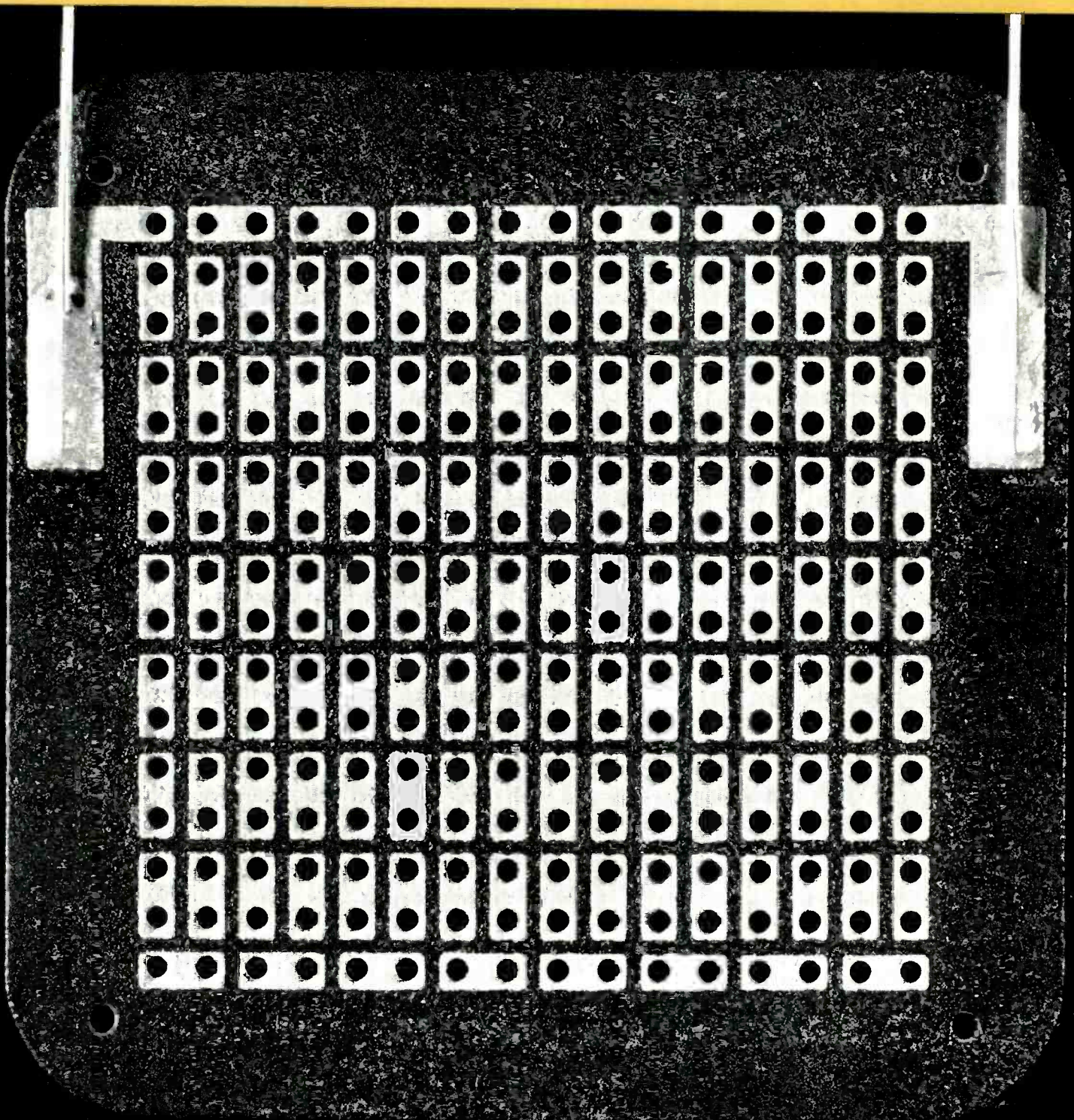

Editorial Board

F. J. Singer, *Chairman*
W. M. Bacon
J. A. Burton
J. W. Fitzwilliam
E. T. Mottram
R. J. Nossaman
W. E. Reichle

Editorial Staff

H. W. Mattson, *Editor*
A. G. Tressler, *Associate Editor*
J. N. Kessler, *Assistant Editor, Murray Hill*
M. W. Nabut, *Assistant Editor*
T. N. Pope, *Circulation Manager*

THE BELL LABORATORIES RECORD is published monthly by Bell Telephone Laboratories, Incorporated, 463 West Street, New York 14, N. Y., J. B. FISK, President; K. PRINCE, Secretary; and T. J. MONTIGEL, Treasurer. Subscription: \$2.00 per year; Foreign, \$2.95 per year. Checks should be made payable to Bell Laboratories Record and addressed to the Circulation Manager. Printed in U. S. A. © Bell Telephone Laboratories, Incorporated, 1961.

Contents

PAGE

- 270 Electronic Memory Devices *D. H. Looney*
- 276 Measuring the Sky's Electrical Noise *D. C. Hogg and H. E. D. Scovil*
- 280 Portable Ruby Optical Maser Demonstrated
- 281 A New Surface-to-Air Data Communication System *J. B. Bishop*
- 285 The Art of Counting Calls *W. B. Callaway*
- 289 A Statistical Ammeter *J. W. Osmon*
- 292 Ferrite Isolator: New Kind of Pad for TJ Radio-Relay *A. F. Pomeroy*

Cover

This ferrite sheet, with its printed wiring contacts, is part of a memory module—one of the many types of memory devices discussed in a review article which begins on page 270.

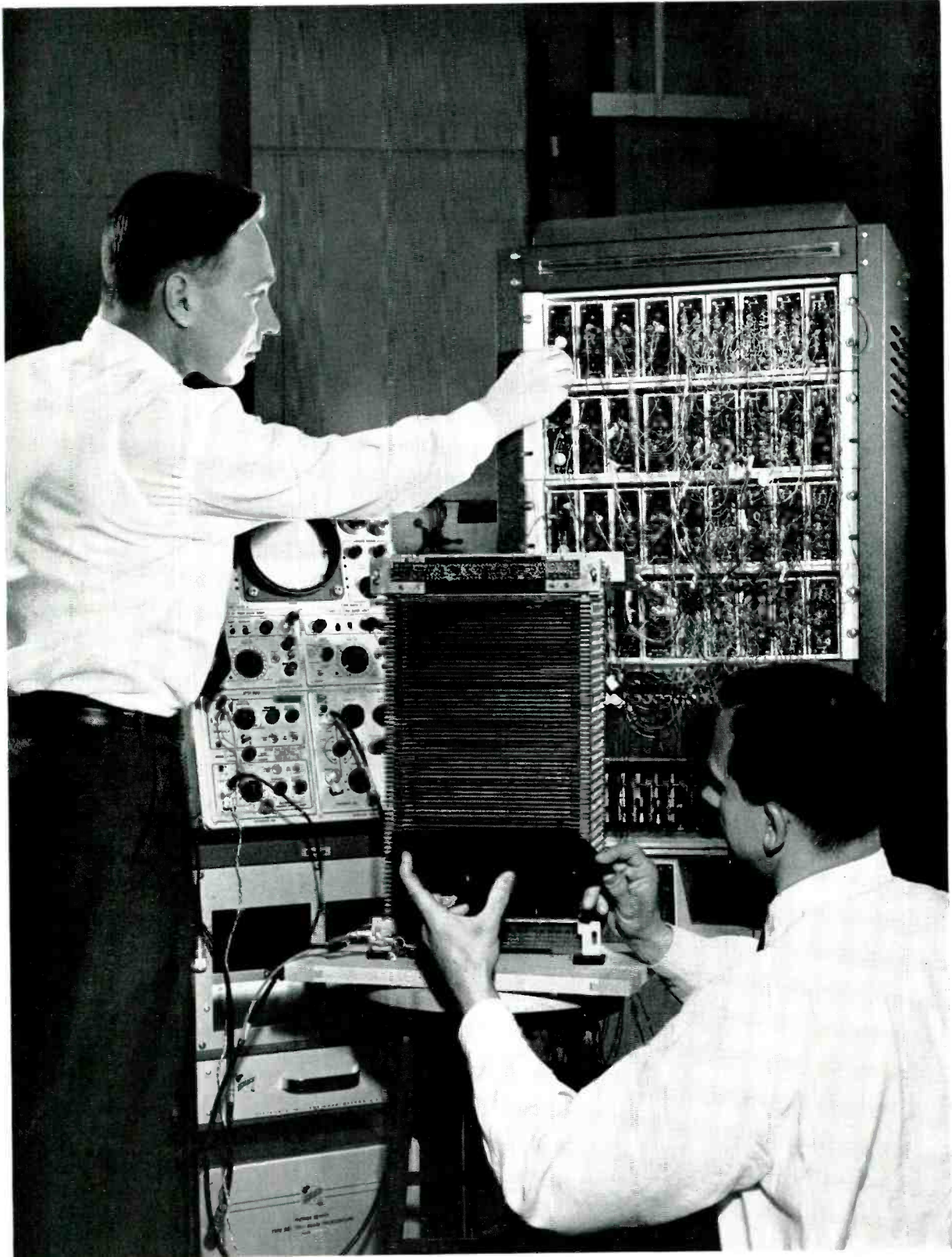

Latest development in transistor memories for large capacity storage is this card-changeable arrange-

ment, demonstrated by U. F. Gianola (left) and J. A. Ruff, Solid State Device Development Department.

Automatic communications systems, with their emphasis on speed and reliability, need fast and dependable memory devices. For this purpose, communications technology has presented the systems designer with several interesting choices.

D. H. Looney

Electronic Memory Devices

Telephone switching systems, and other communications systems of many types, are now being developed to operate at extremely high speeds, measured in millionths of a second. The reason for this emphasis on speed is partly a desire to perform communications services faster, but it is also a desire to process a given amount of information with less equipment. Thus, if the prices of high-speed circuits can be held to reasonable levels, significant savings may result.

"Memory," or storage of information, is only one part of a communications switching system, but it is a very important part. It ranges from storing an item of data for only a very short period—maybe only a fraction of a second—to storing another item for perhaps days or months. For example, when a customer dials a telephone number, memory circuits in the local central office may be required to store all or parts of this number for only a few seconds. On the other hand, other data may be stored indefinitely. The line coming into the office from a telephone, for instance, has an "equipment number"—a number

that identifies the physical location of the incoming line on a particular frame of equipment. This number will exist unchanged until the customer moves or requests a different class of service, or until the office revises this equipment number for some reason.

Another form of information that may be stored for a considerable period is an "instruction." An ordered set of instructions is a "program" which prescribes the decisions and sequence of operations necessary to accomplish the designed purpose of the system—processing telephone calls. Present-day telephone offices are programmed entirely by wiring patterns interconnecting switches such as relay contacts. Programs for future telephone offices will be stored in electronic memories as lists of instructions and changed whenever new features or services are added.

These concepts are important to an appreciation of the many new methods of high-speed, electronic memory. They explain, for example, the classification into "temporary" and "permanent" memories, and they introduce the important role that

memory plays in directing a stored program electronic switching system.

In this discussion, it would be impossible to include every new device and idea being considered for memory applications. Also, in such a rapidly changing field, it is difficult to gain enough perspective to separate the significant developments from the many interesting proposals that may never become economically practicable. The few examples here, however, should give some of the flavor of contemporary work on memory systems, and should emphasize the significance of modern electronics for future communications.

Aside from the general distinction between temporary and permanent memories, storage systems can be categorized in many ways. One of the most basic is to think of them according to the phenomena responsible for the storage. We can imagine almost any discrete effect which exists in two states—for example, a liquid solution can be either electrically conducting or nonconducting. As long as the effect can swing or be “switched” from one state to another, it can be used to design a memory.

Two effects used in electronic memories now under field trial in the Bell System are the presence or absence of an electrostatic charge on a sheet of an insulating material, and the presence or absence of an exposed area on a photographic film. The electrostatic phenomenon is the basis for the design of a barrier-grid temporary memory, and the exposed film is the basis of the flying-spot store or permanent memory—both used in the electronic central office currently under field trial at Morris, Illinois (RECORD, December, 1960).

Barrier-Grid Store

The barrier-grid store is a system having a vacuum tube in which a beam of electrons is directed to the surface of a sheet of mica. Immediately in front of this sheet is the “barrier grid”—a fine screen or mesh of wires that controls the secondary electrons falling back on the mica sheet when the state of the memory is changed. The homogeneous mica surface is divided into a large number of discrete storage areas or “spots.” When the beam impinges on a particular area, the average number of electrons arriving at the surface would ordinarily equal the number of secondary electrons leaving. However, a metal plate is mounted in back of the mica sheet, and when the voltage on this backing plate is properly adjusted, the number of electrons which stick to the mica can be temporarily

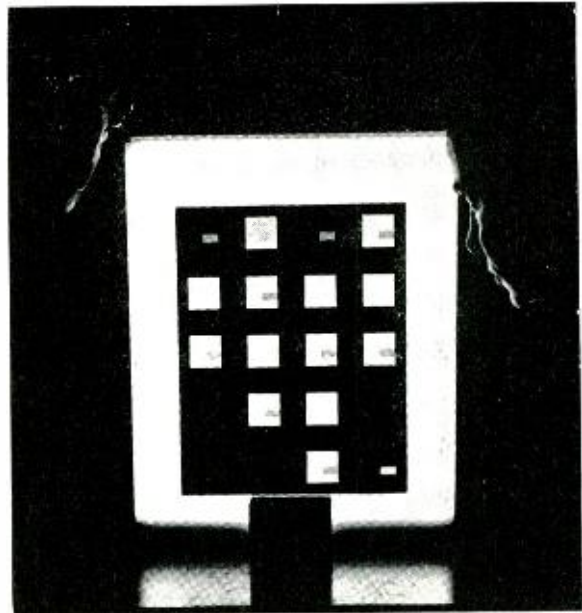

Bits of information are recorded on these photographic plates as tiny clear or opaque dots.

altered. In this manner, the spot stores a small quantity of electrostatic charge. Its presence or absence specifies one binary digit, or “bit” of information.

In barrier-grid tubes now being studied, a typical storage array consists of a square pattern of some 16,284 spots (128 by 128). Each spot is only about 5 thousandths of an inch in diameter. Because of such small dimensions, the electron beam must be positioned and deflected very precisely.

After a charge has been stored on a spot, it can be removed (“read out”) and a new charge inserted (“written in”) in a cycle time of $2\frac{1}{2}$ millinths of a second. The beam can detect the presence of charges (“interrogate”) on only one area at a time, and can thus read out only one bit at a time. Consequently, the barrier-grid tube is particularly useful in systems which handle bits serially. If a number of barrier-grid tubes are operated in parallel, however, the output is a “word” of several bits of information, all read out simultaneously.

In the permanent memory of the experimental Morris Central Office, the data bits appear as transparent or opaque areas on a photographic film. Like the mica sheet of the barrier-grid tube, a single section of film is divided into a square array consisting of a large number of storage areas. In this case, however, the information is

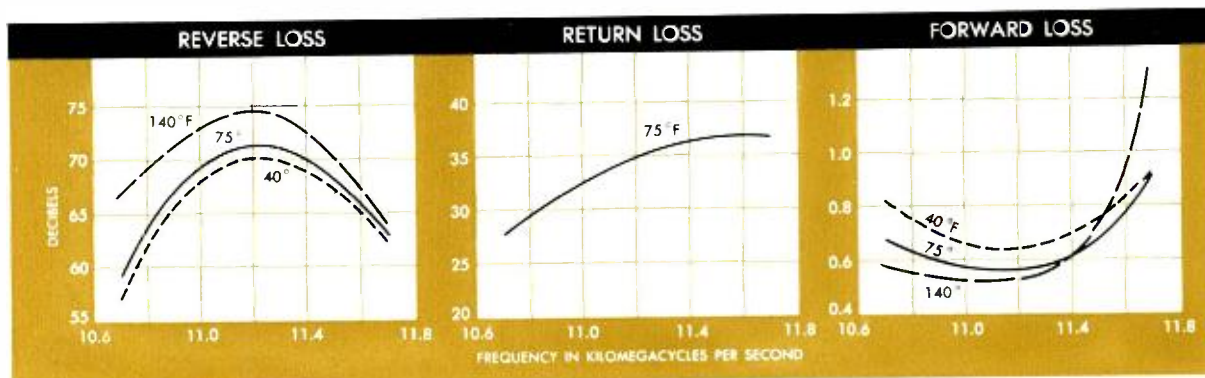

Loss curves for a typical 1A Isolator. The curves reveal a "front-to-back" ratio of 2,690,000:1 over

most of the frequency band. Temperature changes do not appreciably degrade the performance.

zinc alloy. These covers support the pole pieces and keep dust from gathering on the magnets. The pole pieces, made from cold-rolled steel, are aligned with the ferrite bars to achieve the desired magnetic field configuration.

The operation of a field displacement isolator has been explained previously (RECORD, November, 1957). In this rapidly expanding art, theoretical considerations are subject to continuing evolution as experimental observations add to the fund of knowledge. Loss mechanisms in field displacement isolators may now be described as follows: In the illustration on page 292 note that each ferrite bar is in the field of one permanent magnet. Since the direction of circular polarization of a TE_{10} mode is opposite in the two sides of a rectangular waveguide, the magnets of a 1A Isolator are assembled oppositely; that is, a north pole of one magnet should be opposite a south pole of the other magnet. In one direction of transmission, the waves react vigorously with the magnetic fields of the electron spins in the magnetized ferrites. These interactions form electric "walls" on the inside faces of the bars, thus forming a relatively lossless duct between the bars, through which the waves pass practically unimpeded.

In the opposite direction of transmission the waves may be thought of as being "scattered" into the ferrite by the pattern of chrome coating, much as light rays are deflected by a venetian blind. These scattered waves are dissipated in the ferrite bar, causing high reverse loss. In addition, there is some dissipation in the chrome coating.

Since the performance of an isolator depends upon the strength of the magnetic fields in the ferrite bars, the permanent magnets in the new isolator are stabilized to prevent changes in operating characteristics because of magnet aging. This aging may be caused by mechanical shock,

or by ac or dc magnetic fields. A permanent magnet is said to be stabilized if it is partially demagnetized after being fully magnetized. The hysteresis characteristic of a stabilized permanent magnet has the same general shape as that of a fully magnetized magnet.

A simple way of thinking about stabilization is as follows. To magnetize a permanent magnet fully, a very strong magnetic field is applied. This field can be thought of as overcoming the resistance-to-rotation of the most stubborn single domains until they are finally all aligned. Now, if a smaller field in the reverse direction is applied, some of the domains will remember how they were orientated before magnetizing, and will rotate back to their original orientations. As stronger and stronger reverse fields are applied, more domains will rotate back. In the stabilized condition, no additional single domains will rotate back for any reverse field of less strength than that used to stabilize the magnet.

To check the operating characteristics of manufactured assemblies, ten Western Electric isolators were measured in Bell Laboratories for electrical performance. The characteristics of a typical isolator are shown in the graph above. This graph shows results of measurements for many frequencies across the band at a room temperature of 75 degrees F; but at 40 degrees F and at 140 degrees F, measurements were made at band-edge frequencies only. The results indicate that the isolator will be satisfactory over this temperature range.

The 1A Isolator is only one of the many precise components that contribute to the fine performance of the TJ Radio System. Because it is a marked improvement over conventional "pads" of resistive elements, it represents an important step forward in microwave communication.

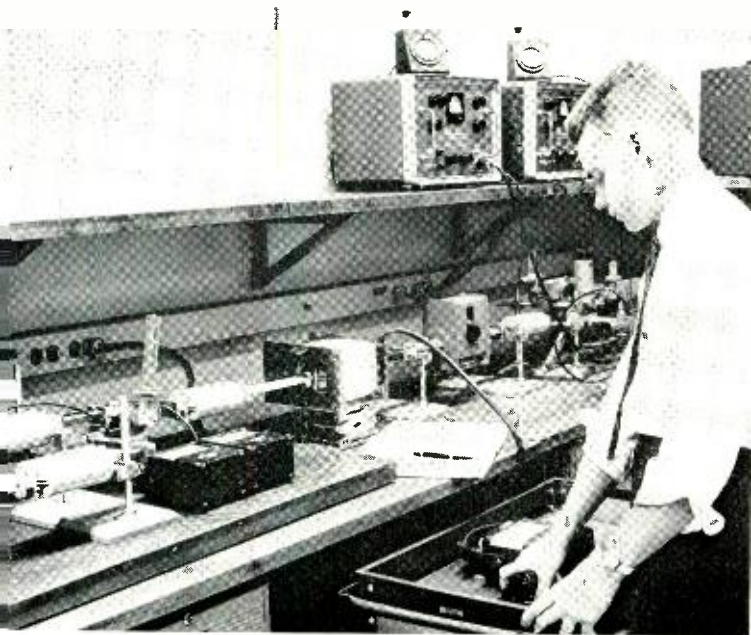

A. R. Johnson shown adjusting a complete 1A Isolator. Alternating current is used to stabilize the magnets to the operating values so that the magnets will remain permanent during years of use.

opposite direction. By using ferrites, ceramic-like magnetic materials, losses can be decreased in the direction of transmission, and at the same time the loss can be increased in the opposite direction. The device achieving these unusual properties is a combination of ferrite and a section of waveguide—the combination being called an “isolator.” Such an isolator is used between the klystron and the antenna waveguide run in the new TJ radio-relay system. The complete isolator is shown in the picture above.

This type of isolating action can be obtained in three different ways: first by Faraday rotation (RECORD, *October, 1955*); second by ferro-magnetic resonance; and third by field displacement (RECORD, *November, 1957*).

The third method—field displacement—is employed in the TJ system. Here, a transversely-magnetized, thin rectangular ferrite slab is located so that its broad face is parallel to the narrow walls of a rectangular waveguide assembly. The position of the slab is critical. It must be in a plane at which the wave is circularly polarized. A more or less conducting film, in a particular pattern, is placed adjacent to one broad face. The film causes the wave—for one direction of transmission—to be scattered into the ferrite where it is absorbed. In the other direction of

transmission, there is little or no scattering, hence, almost no absorption.

The effectiveness of an isolator may be described by stating its forward loss, reverse loss and return loss. An ideal isolator, for example, will cause no attenuation in the transmitting direction (zero forward loss) and complete attenuation in the reverse direction (infinite reverse loss). Further, of all power incident upon the isolator, none would be reflected by the isolator itself (infinite return loss).

In the actual TJ design, the 1A Isolator has (within the 10.7 to 11.7 kmc band) a forward loss of about 0.7 db, a reverse loss of about 65 db, and a return loss of about 32 db. This means that of the available signal power, about 85 per cent is transmitted, whereas only about 0.00003 per cent of the power reflected in the waveguide run or at the antenna reaches the klystron. A return loss of 32 db means that only about 0.06 per cent of all the power which reaches the isolator from either direction is reflected from the device. The complete TJ isolator (see drawing on page 292), consists of two ferrite bars, a section of waveguide in which these are mounted, and two permanent magnets with their associated covers and pole pieces.

Each ferrite bar is of the nickel-zinc type with a layer of chrome evaporated in a pattern onto one broad face. This pattern of chrome scatters the microwave and causes the high reverse loss. The inside dimensions of the waveguide section are 0.9 by 0.4 inch, held to within 0.0015-inch. This dimensional accuracy is required in such a precise device as the 1A Isolator.

The half-cylindrical permanent magnets—which supply a steady-state magnetic field—are fabricated from Alnico V because of its superior properties. The material is cast into final shape because it is very hard. Critical surfaces are ground smooth. Its magnetic properties are obtained by heat-treating the finished part under a magnetic field. In effect, the heat treatment divides the alloy into plates of precipitate arranged in a matrix of rods. The spacing between rows of rods is about 200 angstroms. According to magnetic theory, this small spacing makes it seem probable that the magnetization is accomplished, in a finished permanent magnet, by rotation of single magnetic domains, rather than by movement of domain walls. The magnetic field applied during heat treatment assures that the rods form in the most favorable orientations for making the best permanent magnet. In general, the axes of the rods are all parallel.

The magnets are protected by covers made of a

Pads—networks of resistors—are often inserted into telephone transmission circuits to “smooth” the circuit impedance characteristics. To reduce the insertion loss, yet increase the “smoothing” action, Bell Laboratories has perfected . . .

A. F. Pomeroy

The Ferrite Isolator: A New Kind Of Pad for TJ Radio-Relay

Modern communications depend heavily on microwave radio transmission. In the Bell System, more than half of all long-distance telephone circuits are over microwave radio-relay routes. In addition, as the microwave art advances, radio-relay systems are becoming more economically attractive over the shorter distances. For this reason, Bell Laboratories developed the TJ radio-relay system—a “short-haul” system—which operates in the 10.7 to 11.7 kmc band (RECORD, April, 1959).

Its source of signal power is the klystron. This could be directly connected to the antenna waveguide run if there were no reflections from the antenna to cause a signal distortion. Signal distortions do occur, however. To minimize them within a radio-frequency channel—and at the same time minimize crosstalk between telephone channels—the frequency-versus-repeller voltage characteristic of the klystron should be linear. (The klystron’s repeller electrode is modulated by a baseband signal that may comprise several hundred telephone channels or a television signal.) Unfortunately, this characteristic depends on the impedance of the load to which the klystron is connected; that is, the waveguide run and antenna. The distorting effect of the antenna system is, in effect, proportional to the reflection coefficient of the antenna and the length of waveguide run attached to it.

To lessen the effects of such impedance irregu-

larities in transmission systems at frequencies of 70 mc or less, networks of resistive elements called “pads” are commonly inserted into the transmission circuits. The greater the loss of a pad, the more effective it is in reducing such effects, but the less desirable it is from a transmission loss standpoint, since this loss must be made up by increased amplifier gain.

Pads are inherently two-way devices: a pad introducing 3 db of loss in one direction of transmission will also introduce the same loss in the

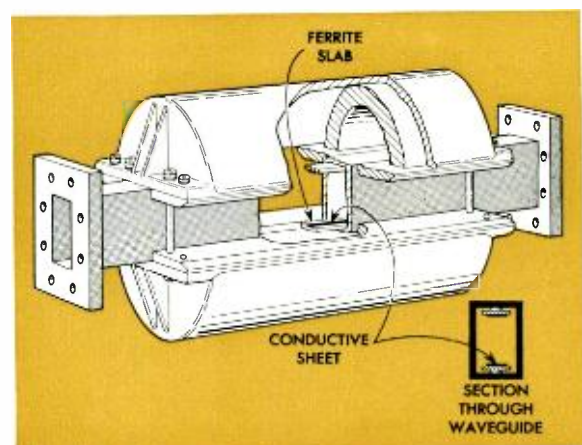

The complete isolator consists of two ferrite bars, a section of waveguide in which these are mounted, and two magnets with pole pieces and covers.

that the unit is light and small. The circuit can be powered from a 48-volt central-office battery. Two type-D dry cells supply the bias voltage for the electronic gates.

Each of the meter's three counters has a limit of 999,999 counts. If they count steadily at five counts per second, they can operate for about 55 hours. However, most test runs will take an hour or less. The counters, which are similar to auto mileage indicators, can be manually reset to zero. The controls for adjusting the sampling frequency and for setting the threshold level of the gates are on one side of the meter and all the inputs, along with the milliammeter and the control for the dummy load, are at the rear. The range-selector switch and various power switches are at the front.

When the meter is correctly calibrated, the counters start counting at a current level that may be as much as 5 per cent below the indicated value. As a result, the recorded count will tend to be slightly high. Tests show that the percentage of recorded time that the load current exceeds the preselected current levels is within 5 per cent of the correct value. This error is always on the high side so the amount of time that the load current exceeds the selected values is slightly less than the value indicated by the meter. In this way, the premeditated error in the meter always produces conservative data.

The statistical ammeter cannot be used to measure the ringing drain in small PBX ringing plants where the load current is no more than 50 to 100 milliamperes. Laboratories engineers feel that it is not usually necessary to measure the ringing drain in the large 6-ampere ringing plants. If the need arises, however, this meter can be modified to extend its range in both directions.

There is a variation in the 20-cps waveform with different types of ringing generators. It is necessary, therefore, to check the meter calibration each time it is used on a different code of ringing machine. Then the meter may be connected in the ringing load circuit and used for two or three short trial runs to determine the approximate range. Once the correct range is selected, a full busy-hour run may be made. At the end of the run, the results are obtained simply by taking the ratios of the 50 per cent, 75 per cent, and 100 per cent gated count and the count of the reference counter.

For example, assume that the ringing plant is rated at one ampere. The meter is set on the one-ampere range and the 100 per cent and 75 per cent counters are used during the run. The results may show that 10 per cent of the

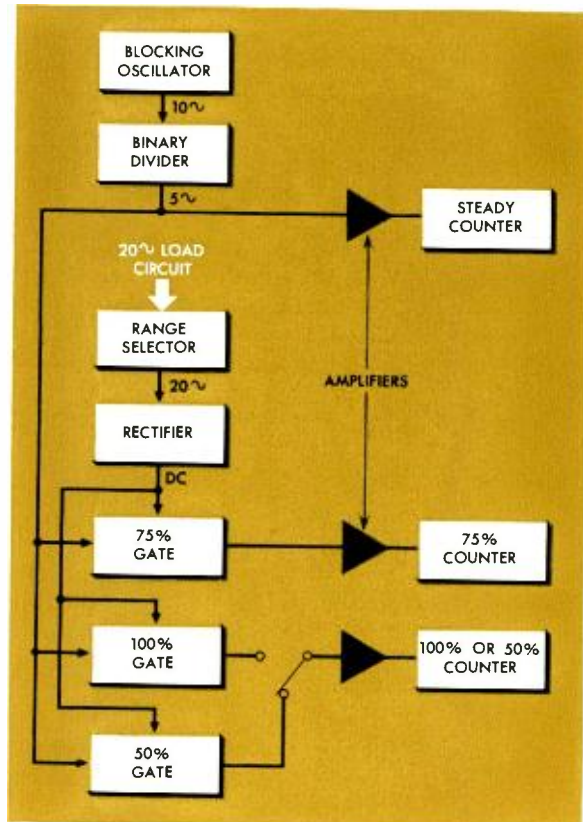

Diagram of the statistical ammeter. The three gates operate when the ringing current exceeds 50, 75 or 100 per cent of the generator's current rating. The counter records duration of current.

time the busy-hour load exceeded or equaled one ampere, and 60 per cent of the time the current exceeded or equaled $\frac{3}{4}$ ampere.

Now, if another busy-hour run is made with the meter still on the one-ampere range and the 75 per cent and 50 per cent counter in use, the results may be something like this: Sixty-two per cent of the time the ringing current exceeds or equals $\frac{3}{4}$ ampere and 96 per cent of the time the current exceeds or equals $\frac{1}{2}$ ampere. Thus, by selecting suitable ranges, the maximum current can be determined and the load current can be measured as closely as desired. The data obtained are sufficient to determine how heavily the ringing machine is being loaded and whether it is necessary to increase the capacity of the ringing power plant.

The new meter is a simple and accurate method of measuring current where the load fluctuates rapidly. This meter makes it possible to design efficient telephone ringing plants and thus minimize service failures and reduce maintenance caused by overloaded ringing facilities.

cause of low-voltage. These low-voltage conditions are often caused by overloads. But they are relatively minor problems. If an area grows at a rapid rate, the power rating of the ringing generators should be stepped up proportionately.

The best way to determine the amount of ringing current passing through a central office is not to estimate it, but to measure it. This avoids a considerable amount of calculation and is inherently more accurate. By measuring the ringing current during the busy hours, an operating company knows without question whether the generators at a specific central office are supplying enough power to ring their customers' telephones. This method also precludes the installation of unnecessarily large generators.

Heretofore, there wasn't any simple method of measuring ringing current. The fluctuation of the ringing current makes it difficult to measure with conventional ammeters. An ammeter provides rather inexact information because its needle is hardly ever at rest. Operating company engineers have used a special 20-cps recording ammeter in some central offices, but this involves a complicated analysis and interpretation.

This article concerns a new type of ammeter—a statistical ammeter—which provides accurate data immediately after a test run. It is portable and can be used with all types of ringing power plants in the field. The meter samples the ring-



E. K. Ward of Pacific Telephone and Telegraph Co. adjusts a gate threshold on a statistical ammeter.

ing current five times a second. If the current equals or exceeds certain preselected levels during the run, an electromechanical counter records these levels as "interval counts." The preselected levels, which are based on the size of the generators, are chosen with a range-selector switch. To find out the proportion of time that the ringing current exceeds the preselected levels, the interval count is compared to the count from the reference counter. The results are expressed as the proportion of time that the ringing current equals or exceeds 50 per cent, 75 per cent, and 100 per cent (or any other preselected percentage) of the current rating of the machine.

The sampling rate of the statistical ammeter is set by a 5-cps square-wave generator. The amplified output of the generator drives a reference clock counter at the rate of five counts per second. The same 5-cps square wave is fed through electronic gates where it is amplified to drive two other counters. The level of the ringing current controls the operation of the gates. The voltage drop across a resistor through which the ringing current passes is stepped-up with a transformer, then rectified and filtered. The resulting dc signal turns the gates on or off.

There are three gates in the circuit. One is adjusted so that whenever the ringing current equals or exceeds 75 per cent of the range-selector setting, the 5-cps square wave passes through the amplifier to a counter which operates at 5 counts per second. The other two gates are adjusted so that they will be turned on when the ringing current equals or exceeds 50 per cent and 100 per cent of the setting for the range-selector switch. The 75 per cent gate is connected permanently to one amplifier and counter, and either the 50 per cent or 100 per cent gate may be connected to the other amplifier and counter.

The range selector consists of resistors chosen so that the voltage drop at full load is about two volts on each range. The available ranges are $\frac{1}{8}$, $\frac{1}{4}$, $\frac{1}{2}$, 1, and 2 amperes. These ranges were chosen to correspond to the full-load current ratings of 20-cps generators commonly used in ringing power plants. The different range resistors may be readily switched into the circuit with the range-selector switch. A variable resistor acting as an adjustable dummy load for the ringing plant and an ac milliammeter are used to calibrate the meter. The calibration procedure, although carried out on the $\frac{1}{4}$ -ampere range, is valid on all ranges.

The meter operates on low power because all of the active elements in the oscillators, amplifiers and gates are transistors. This also means

A short burst of electric current makes your telephone ring. Because operating telephone companies must know how much current is required to ring hundreds of telephones like yours, they needed a combination of a pulse counter and an ammeter.

J. W. Osmun

A Statistical Ammeter

The usual method of measuring electrical current is with an ammeter. However, to measure the amount of 20-cps current required to ring the hundreds of telephones served by a central office, we need a meter that "counts" rather than one that momentarily indicates the peak flow of electric current. In other words, telephone company engineers must know *how long* as well as *how much* ringing current passes through a central office.

From traffic estimates, engineers can calculate with reasonable accuracy the expected ringing current for new central offices. With these estimates, operating companies initially can select generators with enough capacity to provide ringing current for immediate needs as well as allowing for future growth. After a central office is in service for several years, however, it becomes difficult to determine how much electrical energy its generators provide.

Telephone engineers can estimate the current required by determining the total number of telephones served by a central office, the number of these phones used in businesses and in homes, and the types of service. But there are

many cases where this information is either inaccurate or unavailable. Further, there are so many variations in service and customer telephone habits from one central office to another that such estimates are never wholly dependable.

The basic problem of determining the amount of ringing current lies in the way the generators function. A ringing generator can deliver only so much current before its output voltage drops below the satisfactory minimum. Thus, peak load current actually determines the size of a generator. The average ringing current, however, is much smaller than the peak current and cannot readily be correlated with it.

Where ringing current drains are calculated according to probability theory, the generator output can exceed the generator rating by 20 per cent or more only one per cent of the time. These momentary overload periods mean that a few telephones farthest from the central office may not ring. This isn't serious because such overloads last only a few seconds, and these telephones will probably ring on the next ringing cycle, usually six seconds later. Occasionally, central offices complain of alarms being set off be-

three upward and three downward spikes corresponding to the three count signals that occurred, and we can count these as individual calls, even though their original durations partly overlap. Within some limitations, an adder with several branches followed by a differentiator gives the same results as several differentiators followed by a single adder, and it is much less expensive.

A final trick from the bag has to do with display of the total count after it is obtained. Customarily, individual counts are displayed on four-digit electromechanical registers. These can be read manually or photographed. Traffic engineers want the electronic method of totalized count to be displayed in this same familiar form. Even a modern electromechanical register, however, requires about 1/20th of a second to count a pulse, release, and be ready for a subsequent pulse. Thus, if this counter is counting pulses at a constant rate of 20 pulses per second, or 72 thousand an hour, it will be busy 100 per cent of the time, and unable to count additional pulses.

Count Reducer

To be accurate to within about 0.1 per cent on *randomly* occurring pulses, such a counter must have its "busy" periods restricted to approximately 0.1 per cent of the time. It can, therefore, only be exposed to an average of 72 counts per hour—not enough for our purposes. Obviously, if the desired electromechanical register is to be useful, some sort of scaling-down or count-reducing arrangement will have to be placed ahead of it.

In serving telephone traffic over trunk groups, we know from probability theory that ten trunks can handle over 3000 times as many calls as a single trunk for a "probability loss" of 0.001. Similarly, we can increase the capacity of a single electromechanical counter by preceding it with a single electronic "scaler." This will permit every tenth call to operate the counter. With this modification, the capacity of the counter for 0.001 probability of loss is increased from an average of 72 calls per hour to an average of, not 720 calls, but *213,000* calls an hour. Insofar as lost calls are concerned this capacity is ample for any proposed system application.

The foregoing set of simple principles is all that is required to permit pulse counting in electromechanical systems. A more sophisticated problem, of course, is the integration of these basic techniques into a design where circuit complexity and cost are optimally balanced against requirements of counting accuracy. Such a circuit is now in the final stages of design at Bell Laboratories.

Nike-Zeus Fired From Underground Cell

A test firing of a Nike-Zeus missile from an underground cell at White Sands Missile Range was successfully completed last month. The missile's flight was guided by the Command Guidance System developed at Bell Laboratories. This was the first firing from an underground cell of the advance configuration of the missile designed to counter ICBM's.

Project engineers at the Laboratories said that the test was a significant achievement in the Nike-Zeus development program. It demonstrated that the Zeus system guidance equipment is fully capable of controlling the missile. The Command Guidance System used in the Nike-Zeus system was developed at the Whippany Laboratory and is manufactured by Western Electric at its North Carolina works.

In last month's flight, the missile performed satisfactorily over an extended range and all test objectives were met. The principal items tested were in the Command Guidance equipment, designed to track and guide the missile in completely automatic operation. The underground launch concept was previously demonstrated using a modified version of the earliest Zeus missile design. The underground cell is a prototype of the launcher which is planned for the missile defense system.

The Nike-Zeus system is being developed by the Laboratories under a Western Electric Company prime contract with the Army Ordnance Missile Command.

Western Electric Awarded UNICOM Contract

Western Electric Company has been awarded a \$19,101,500 contract by the U.S. Army for continued development of a *Universal Integrated Communication System (UNICOM)*.

The system will provide switching and terminal facilities for a world-wide complex of voice, teletype, facsimile and other forms of communication. The network is expected to embrace a variety of transmission forms, including the use of artificial satellites.

Western Electric is prime contractor for UNICOM. The system is being developed by the Laboratories at its Whippany location. Subcontractors will be used as appropriate.

mechanical dial system, when we try to produce very short spikes by differentiating count signals we run into trouble because these signals are created by closures of contacts on electromechanical relays and switches. Such contacts do not merely close; they slam together, then quiver a while, making rather imperfect contact. They may even bounce open again before settling down to produce a nice steady "on" signal. Thus, a closure may actually produce an "on" signal like that at the left of part "b" of the diagram. If we use too short an RC value, a register will get a spike for each short, preliminary closure or open and will count each call several times.

Single Downward Spike

However, as indicated in part "c" of the figure, we can select RC values to produce a long enough spike so that the contact chatter is included as part of it. This leaves the second spike, the one at the end of the "on" interval, as the only downward spike accompanying the signal. We can easily arrange to count only this one, and while this is not evident in part "c," the downward spike may have a duration only a small fraction of that of the original closure.

Actually, applying differentiating circuits to the input signals constitutes a form of frequency selection. That is, we have selected the medium frequencies representing the transition from "on" to "off" (and vice versa), and have discarded the very low frequencies which give "body" to the input signal by representing its relatively long duration.

In addition to rejecting the low frequency content of the input signal, it is also desirable to reject the very high frequencies which are picked up on the input leads. This is because such frequencies can easily radiate from one lead to another in central office cabling and we might find ourselves counting signals from circuits not attached to our input. For this reason, some simple arrangement to attenuate frequencies above 2000 cps is generally placed at a common point in the count-pulse path.

Another technique for eliminating a tendency to score extra counts involves characteristics which may be given to a pulse-producing circuit called a "flip-flop." A flip-flop, as the name suggests, acts like a light switch—it is either "on" or "off." There are several varieties but the type which is useful in a pulse counter is illustrated in part "d" of the accompanying diagram. This flip-flop accepts an input signal such as the one

shown, and the first time the input signal exceeds a certain "trigger level" the flip-flop puts out a spike whose duration may be made practically as long or short as desired. Moreover, the flip-flop can be made to have a recovery or "dead" time following each spike which is also adjustable over wide limits. Thus, the device gives a very brief output spike when its input signal exceeds a set level and it ignores later input signal excursions caused by contact chatter or bounce.

Another technique, not necessarily restricted to pulse counting, is handy because it saves money. This is the technique of "adding" the voltages representing two or more calls. As illustrated in part "e" of the diagram, four separate inputs connect through resistances to an output. The actual values of voltage or current in such a circuit depend on the connecting circuitry, but in general the output signal at any instant has a value roughly proportional to the sum of the input signals appearing at that instant.

Thus, if input signals such as those indicated come in on terminals 1 and 2, the output signal is the sum of these. This sum signal, sent through an RC "differentiator," obtains the differential of the sum signal. Note that we now have

Techniques for counting electromechanical pulses.

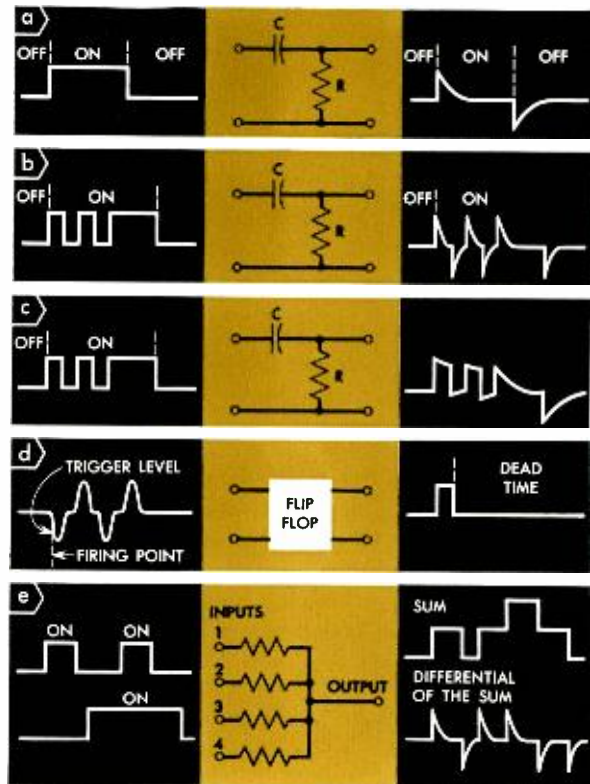

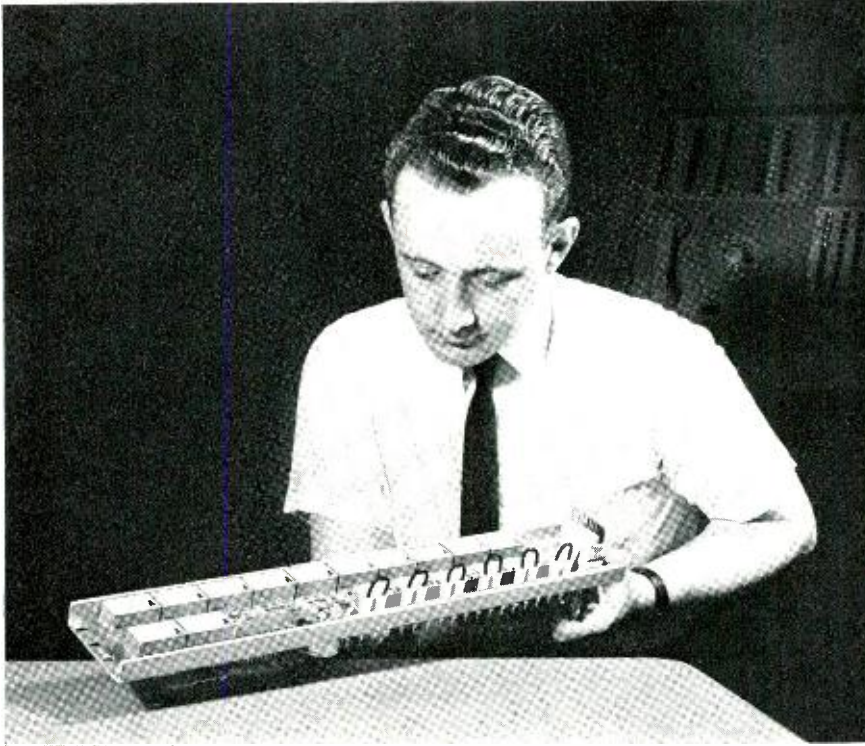

Arrangement of components for electronic pulse counter. Design balances complexity and cost against required accuracy.

lasting for 100 milliseconds, onto one wire for counting, there are going to be many occasions when two or more count signals will partly coincide and will appear merely as one long signal rather than as two or more separate counts. Under these conditions, we might expect that many count signals would be missed. In actual practice, from a third to a half of the counts would be missed, depending on the specific counting mechanism used in the system.

Shortening Signals

Obviously, each call signal has to be drastically shortened if all are to parade single file into one counter. But even with a very brief signal, occasionally two count signals will arrive so nearly together that they cannot be distinguished as separate calls. Losses of counts from this cause can, however, be kept insignificant if the count signals can be shortened enough.

For example, if we make each count signal only 1 millisecond long and count an average of 20 thousand calls an hour, our counter is working or "busy" for only 20 thousand milliseconds or 20 seconds out of each hour. Since there are 3600 seconds in each hour, the counter is occupied only 20/3600, or about one half of one per cent of the hour. Thus, according to probability theory, we

miss only about one-half of one per cent of the counts, making our count 99.5 per cent accurate. This is better than the accuracy ordinarily obtained by present methods.

Consideration of how short a count signal should be, together with consideration of the cost of various ways of producing short counts, points up a second difficulty. About the cheapest and easiest way to turn a long signal into a short one is to pass it through a so-called RC differentiator circuit, as indicated in the diagram appearing on the next page.

At the left in part "a" of the diagram is an "on" signal representing a count to be shortened. After passing through the RC circuit, this signal consists of a short "spike" corresponding to the start of the "on," and another "spike" of opposite polarity corresponding to the end of the "on." The duration of these spikes is determined by the values of resistance and capacity making up the RC circuit. By selecting proper RC values, these spikes can be made very short indeed. We may select either the upward or the downward spike for counting. We can feed many such short spikes per hour into a counter with few calls lost from over-lapping.

Unfortunately, however, we cannot use this attractive scheme just by itself. In an electro-

Telephone traffic engineering and plant administration are based on knowing when and where telephone calls originate. To keep track of calls accurately, Bell Laboratories is designing an electronic pulse counter.

W. B. Callaway

The Art of Counting Calls

Customers of the Bell System originate about 300 million telephone calls a day. Keeping track of this huge volume of business is a vast undertaking, but it must be done if the Bell System is to handle properly its traffic problems. Only in this way can the Operating Companies effectively distribute their switching and transmission facilities to take care of the growth and other changes in customers' telephone requirements.

At present, the Operating Companies use approximately 400,000 mechanical traffic registers to count originating telephone calls. These registers must be "looked at" about 100,000 times a year. The time taken to read the numbers, when translated into the wages of the clerks doing the reading, amounts to nearly one-and-one-half million dollars. Furthermore, such activity wastes human talents.

In the interests of saving some of this clerical expense, and, at the same time freeing personnel for activities more in keeping with their abilities, Bell Laboratories has investigated the use of electronic techniques for the counting function. Electronically, it is possible to count signals on one central register which are now recorded on

many scattered, individual registers. In this way, the Bell System can reduce its 400,000 registers to a few thousand, and thereby save about a million dollars a year.

The counting itself poses no particular design problem. Electronic counters have long been available to handle many thousands of counts a second. And since the total number of calls to be handled at any one place rarely exceeds about twenty thousand an hour, even a partly electronic, partly mechanical counter can easily do the job.

The real difficulty lies in trying to jam all the individual count signals onto one wire without having them merge into an unrecognizable jumble. The situation is similar to one where every car in a city suddenly tries to go down a single street at the same time.

The first part of this problem involves the length or duration of each original count signal. These signals were originally intended to operate electromechanical registers which require a "long" signal to give the register time to function. Therefore, most of these signals last more than 100 milliseconds.

Now, if we merge 20,000 pulses an hour, each

pearance of a standard display on his "scope." If he does not get this indication within a few seconds, he can assume a malfunction exists somewhere in the system. In this case, he will normally request further information and instructions over his voice-radio telephone circuit. The pilot would make no attempt to service the equipment during a flight under any conditions.

Prior to take-off, each aircraft will be given a pre-flight check-out while still on the flight deck. A test set the size of a suitcase is plugged into a jack on the side of the aircraft to verify that the communication system is in good working order. If trouble exists, the major unit involved can be identified in seconds. The defective unit can then be readily and speedily removed and replaced by a tested spare. At some convenient later time, the defective unit is taken below decks to a "test bench facility," where it is again checked in a simulated system. More detailed tests then are applied to indicate which of the various modules is responsible for the difficulty. When the module in trouble has been located, it is replaced by a tested spare and the major unit thus restored to

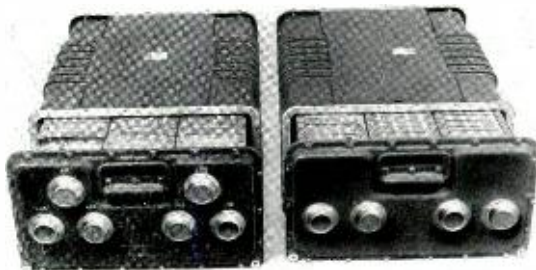

Digital-to-digital (right) and digital-to-analog converters of the airborne controlled terminal, showing some of the typical plug-in modules used.

service. Normally no attempt will be made either to locate or repair the defective component within the module at this time. Rather, the defective module will be returned to a similar land-based test-bench facility for ultimate test and repair.

In addition to the tactical uses implied above, this data communication system is designed to help direct aircraft in support of marine landing operations. It also will afford opportunities for a wide variety of applications in future military and commercial communication systems. With high-speed, digital data systems such as this, surface/air communication methods are keeping pace with the ever-increasing speed and complexity of present-day Armed Forces aerial operations.

Command Guidance Puts Tiros III in Orbit

The National Aeronautics and Space Administration's TIROS III weather satellite, launched last month at Cape Canaveral, was directed into its circular orbit by the Bell Telephone Laboratories Command Guidance System.

This launch was the third successful use of the guidance system for TIROS (Television Infra-Red Observation Satellite) satellites and the fifth time command guidance has been used successfully in NASA's space research program. TIROS I was sent into an almost perfect circular orbit on April 1, 1960, and TIROS II, which is still transmitting meteorological data, was launched into a similar orbit on November 23 last year. TIROS II may be "turned off" now that its successor is in orbit.

News of Space Research

The orbit of TIROS III is 509 miles at its apogee and 458 miles at its perigee. It passes 48 degrees north and south of the equator on each of its 100-minute trips around the earth.

The NASA-developed, Douglas-built THOR-DELTA vehicle used to launch TIROS II and TIROS III was also used to place ECHO I, the passive communications satellite, and the Space Agency's Explorer X magnetic-field probe into their precise orbits. The other satellites and space probes in NASA's DELTA series will also be directed by the Bell Laboratories Command Guidance System.

This guidance system, which Bell Laboratories developed for the Air Force Ballistic Systems Division for the TITAN I weapon system, is manufactured by the Western Electric Company. Command guidance employs a special, ground-based digital computer—Athena—developed and manufactured by Remington Rand Univac.

The 285-pound TIROS III satellite differs slightly from its predecessors in that it has two wide-angle cameras instead of one wide-angle and one narrow-angle camera. This change was based on earlier experiments, which showed that more valuable information for weather analysis was available from the wide-angle pictures. It also carries three infra-red sensors to measure sun-earth radiation relationships.

TIROS III, like its predecessors, is designed to gather and record weather data which it spills out as it passes over command and readout stations at Pacific Missile Range, California and Wallops Island, Virginia.

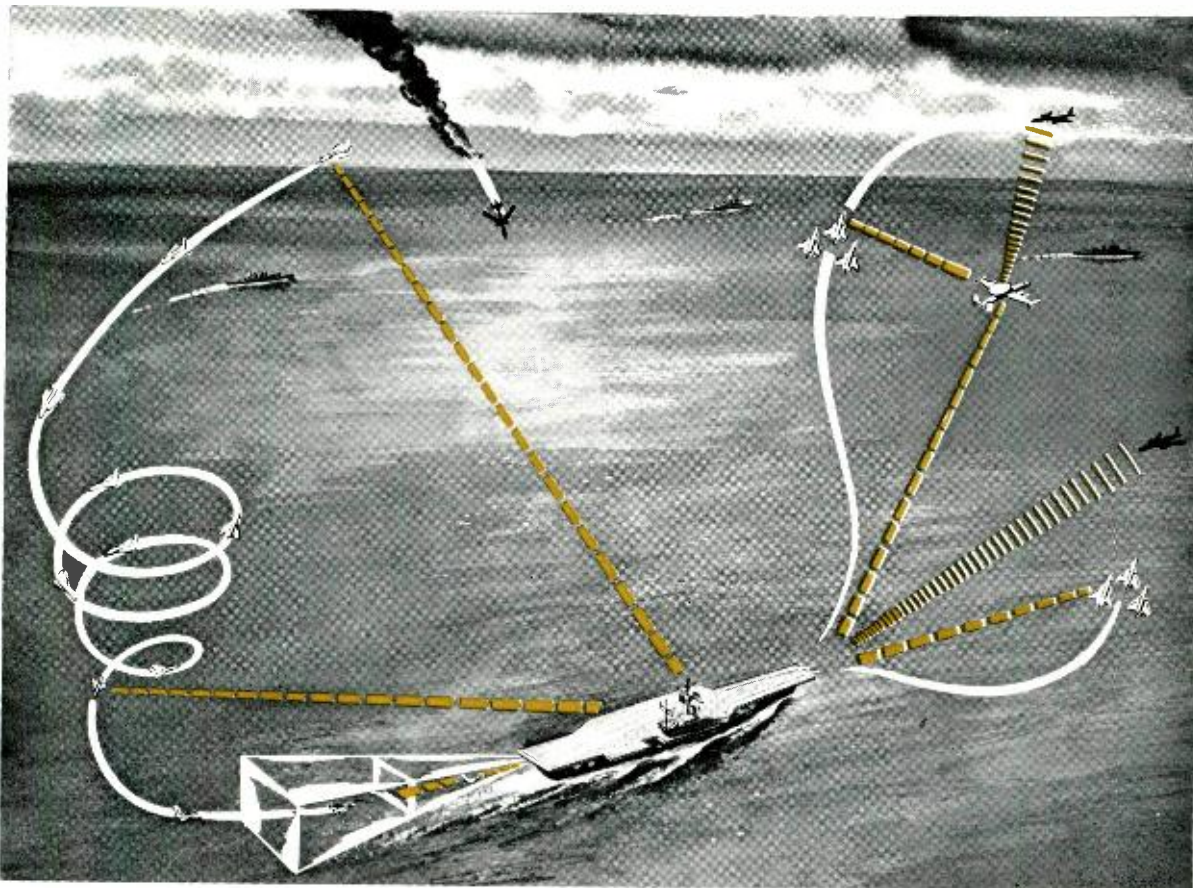

Right-hand section shows aircraft being directed toward their targets both from aircraft carrier and from early warning type aircraft. At left,

interceptors are guided back to carrier and landed. Dashed colored lines represent coded radio messages, while curved lines represent radar waves.

modules. The digital-to-digital converter contains 37 similar, but not identical, modules. Printed circuitry is employed throughout the modules. Also, wherever possible, each plug and jack element is split so that, when connected, they make four parallel connections at each plug-jack junction. This feature, in combination with self-aligning jack strips, helps insure good, permanent contact. At the same time, it permits quick removal and replacement when required.

Portions of the airborne controlled terminal will occasionally be subjected to temperatures considerably higher than certain of its components can withstand as designed. Therefore, each major unit is self-contained in a pressurized, air-cooled chamber. This chamber also protects the components from moisture and air density variations which would otherwise affect the reliability of operation. The whole is cooled by a heat-exchanger, through which air circulates from the aircraft's cooling system. The principle employed for cooling by forced air circulation on both sides

of the heat exchanger is illustrated in the diagram on page 282.

Although every effort has been made to insure reliability and complete freedom from trouble during a mission lasting at least two hours, the question still arises as to how so much compact circuitry can be serviced in any reasonable time when trouble does occur. The problem is especially difficult since such service will have to be handled by personnel who are not highly trained in the art. The answer to this question lies principally in the type of monitoring facilities and testing techniques used. A brief description of how they work in the airborne controlled terminal will serve as an illustration.

During a mission, the interceptor pilot is automatically alerted by a visual or audible signal if for any reason he should fail to get a message every few seconds. In addition, if and when he wants assurance that his equipment is functioning properly in all respects, he has merely to press a button on the control unit and observe the ap-

system can provide two-way communication to as many as 100 aircraft over a single radio-frequency channel. Each of these aircraft can be given a complete set of individual instructions once every few seconds. The two-way feature permits each addressed aircraft to reply with a comprehensive status-type message derived from information generated aboard the aircraft.

Two basic types of communication terminals are supplied: A control terminal located either on a surface vessel or in an early warning type of aircraft; and a controlled terminal located in the interceptor or fighter aircraft. Both types of terminals are small and light-weight. They are also capable of encoding, decoding, and dispatching the command and reply messages accurately at the prodigious rate of some 10,000 words per minute. This accomplishment was realized by making full use of all the latest pertinent technological advances in the fields of data processing and digital data communication. More specifically, the major units of the system, up to the very radio frequency signals, are completely transistorized, and the system operates as a two-way device on a single line-of-sight radio frequency channel in the UHF range.

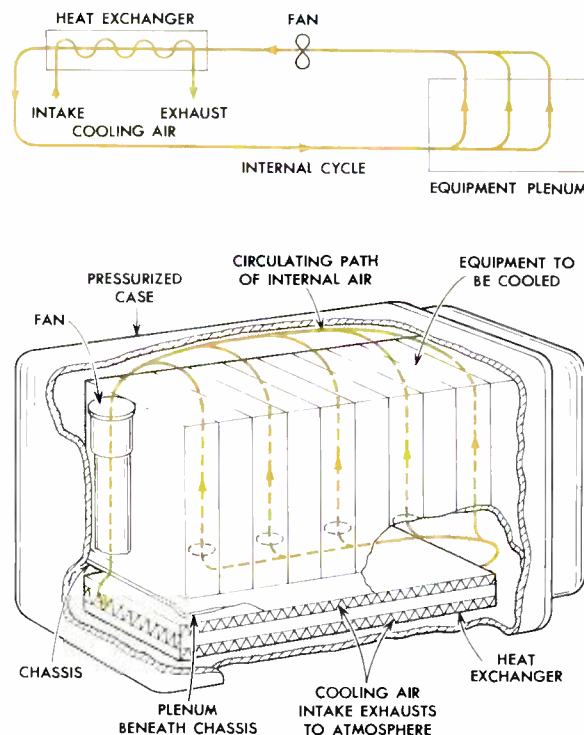

Cutaway showing heat-exchanger used to keep major communication units cool in operation. Incoming air comes from aircraft's cooling system.

To avoid ambiguity in dispatching messages, each aircraft is given a discrete address. This allows the message sent to a particular aircraft to be received only by that aircraft. At the direction of the pilot or the controller, the message sent to the interceptor aircraft is either fed directly into the autopilot (in which case only limited action is required on the part of the pilot) or "painted" on his radar scope in a pictorial display. In this case, the pilot "gets the picture" instantly, without having to perform time-consuming translations or computing processes. In either case, at the completion of the control message, a reply message indicating the aircraft's status is automatically encoded and dispatched back to the control terminal. This status message is continuously generated from "own aircraft" instruments and navigation devices, and thus requires no expenditure of effort by the pilot.

Service Conditions

A number of exacting requirements had to be met in developing this data link for the Navy, because of the service conditions under which it would be used. The equipment not only had to be small and light-weight, but it had to function reliably and without failures at high altitudes, under extreme ranges of temperature, humidity, shock and vibration. Finally, it had to be so constructed that it could be operated and maintained by personnel who were relatively unskilled in servicing highly specialized electronic equipment. For these reasons, great care has been exercised not only in the choice of components but in the choice of circuits and in the mechanical arrangement of the circuit components.

For example: engineers carefully considered the relative merits of using transistors versus tiny magnetic cores for the shift register elements in the data multiplex unit. They ultimately decided to use cores on the basis of the specific job to be done, taking into consideration the relative reliability, circuit complexity and the ease of identification and correction of a trouble condition if one should develop. In this instance, system reliability is concerned principally with the intrinsic reliability of the component (transistor or core device) and the large number of components required.

While we have said little regarding the specific equipment design, circuit compactness in an application such as this is a "must," and is perhaps well illustrated in the photograph appearing on page 284. Both the digital-to-digital and analog-to-digital converters of the airborne controlled terminal are made up of individual functional

Carrier-based aircraft now fly faster than the speed of sound. To direct the Navy pilots to their missions and get them safely back, Bell Laboratories developed a new digital data communication system.

J. B. Bishop

A New Surface-to-Air Data Communication System

Speed in military aircraft has long been recognized as essential in maintaining air supremacy for our Fighter-Bomber forces. Development work in this field made rapid strides during World War II, and since that time jet aircraft have completely superseded the propeller-driven type in this application. Air speeds equal to that of sound and above are now commonplace for these manned vehicles.

To keep pace with these changes, our communication facilities have also had to be radically revised. Using conventional communication systems, not more than a few of these high-speed interceptors could be guided to their targets by a director issuing voice commands over a single radio channel. Communication requirements of aircraft in other phases of their mission, such as returning to base and landing, magnify this problem. Clearly, postwar surface/air communication systems required the same type of progressive development that enabled the aircraft industry to replace its slow-speed propeller type aircraft with the high-speed jets now in use.

To meet this challenge, Bell Laboratories has

developed a high-speed, surface/air digital data communication system for the U. S. Navy. The system, known as AN/USC-2, provides two-way communication under all weather conditions. It can be used to direct large numbers of Navy interceptors simultaneously to their several targets and, after they have completed their missions, put them in a homeward-bound traffic pattern which will eventually bring them to a safe landing on the deck of a carrier.

The facilities with which we are concerned in this article will be confined to the Data Link communications portion of a completely integrated air defense system. Concurrent developments by other organizations have furnished the high-speed computer, automatic radar-tracking devices, displays, and other necessary supporting facilities required at the control terminal. A great deal of attention has also been paid to the matter of insuring a high degree of compatibility with the surface air communication facilities used by other branches of our armed services, as well as by those of other NATO countries.

This time-division digital data communication

The newest maser design to come from Bell Laboratories is one for a portable device that can be hand held and operated. Its power supply is contained in a small case.

Portable Ruby Optical Maser Demonstrated by the Laboratories

A portable, pulsed-ruby optical maser, which operates on less than one-tenth the input power of standard sized masers was demonstrated by R. J. Collins of Bell Laboratories at the International Conference on Optical Instruments and Techniques in London last month.

The light-weight optical maser can be hand-held and operated with an input power of only 128 joules from a portable power pack. Standard-sized ruby optical masers are several times larger and require hundreds of pounds of auxiliary power equipment to supply about 1500 joules of pumping power.

News of Solid State Research

The standard-sized maser uses a xenon flash lamp, wound spirally around the ruby rod, to stimulate maser action. The new maser, designed by J. W. Ammons of the Solid State Electronics Research Department, is made smaller and lighter through the use of a different type of flash tube enclosed in an elliptical reflecting cavity.

A U-shaped, xenon flash tube is at one focal line of the elliptical cavity. The 2-inch by 0.2-inch ruby rod is at the other focal line. Therefore, almost all the light from the lamp is focused onto the ruby rod. The ruby shows stimulated emission on only about 128 joules.

The ends of the ruby rod are exposed. One end is partially reflecting and permits a very bright spot of light to emerge. The other end has two slits etched on it so that an interference pattern can be projected, demonstrating the coherence of the maser light.

The power for the flash tube is supplied by a nine-pound power pack measuring approximately

9 x 9 x 3 inches. The ruby can be fired at ten second intervals and does not require cooling.

Mr. Collins explained that the portable model had been developed for demonstration purposes at lectures and seminars, but that it will probably have other applications where space is limited.



J. W. Ammons sights along portable maser housing. The power supply hangs from his shoulder.

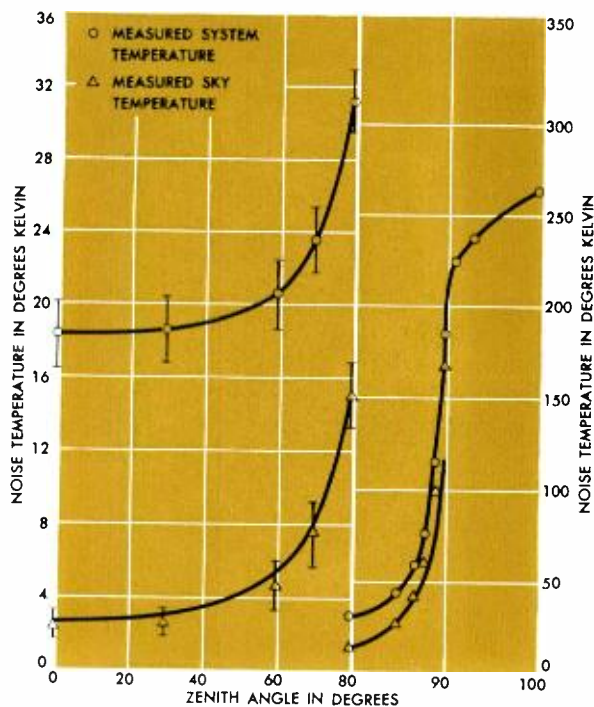

System and sky noise vary according to zenith angles. Theoretical calculations agree closely with those obtained from actual sky measurements.

coupled from the noise lamp permits computation of the temperature of the over-all system.

The sky noise measurements were performed on cool, clear winter nights so that the atmosphere would approximate the "standard" atmosphere. A total of 250 individual measurements were made of the system temperature with the antenna directed at the zenith. Another set of measurements were then made with the antenna pointed at different elevations.

Since the sky temperature is proportional to the length of the antenna beam through the atmosphere, it may be separated from the remainder of the system temperature figure through use of the observed variation with zenith angle. The observed values agree well with the theoretical curves up to the point where the two-degree antenna beam intercepts the earth.

The measured sky temperature agrees excellently with the theoretical calculations. The minimum receiving-system noise that can be obtained theoretically in an earth-based receiving system pointing toward the zenith is the sky noise, and is approximately 2.5 degrees K at 6 kmc. Practically, of course, we must contend with other noise contributors. Nevertheless, the Laboratories arrangement proved to have an over-all system

noise temperature of less than 20 degrees K.

Such systems could be improved as much as 2 degrees K by reducing losses in the input waveguide. Also, design changes in the maser feed could reduce the noise by 5 or 6 degrees K. Thus, it appears that a system noise temperature of only 10 degrees K could be realized at the zenith. In this case, designers would be under pressure to keep the amount of physical structure to a minimum. For example, at such a noise temperature, the additional noise contributed by only 5 feet of 6 kmc waveguide would halve the sensitivity, necessitating a very expensive doubling of the required transmitted power.

Important to space communications is the variation of the sky noise. The major variation comes from changes in the content of the atmosphere; rain, for example, produces changes. To study these variations, the Laboratories has initiated a long-range investigation of sky noise and for this reason has replaced the temporary system with a permanent one.

From the results of the sky noise study, we can now evaluate the performance of a satellite communications receiver. Low-noise equipment is now available, and at the proper frequency it will be possible to send signals around the world with a minimum of interference.

Special Echo Issue of BSTJ

Data gained in the balloon-bounce experiment of Project Echo have now been summarized, and appear in the July issue of the Bell System Technical Journal. Titles include:

Participation of Bell Telephone Laboratories in Project Echo and Experimental Results, W. C. Jakes, Jr.

System Calculations, C. L. Ruthroff and W. C. Jakes, Jr.

960-mc, 10-kw Transmitter, J. P. Schafer and R. H. Brandt

Receiving System, E. A. Ohm

A Horn-Reflector Antenna for Space Communication, A. B. Crawford, D. C. Hogg, and L. E. Hunt

The Dual Channel 2390-mc Traveling-Wave Maser, R. W. DeGrasse, J. J. Kostelnick, and H. E. D. Scovil

Standby Receiver System, L. U. Kibler

FM Demodulators with Negative Feedback, C. L. Ruthroff

Satellite-Tracking Radar, O. E. DeLange

961-mc Lower-Sideband Up-Converter for Satellite-Tracking Radar, M. Uenohara and H. Seidel

Antenna Steering System, R. Klahn, J. A. Norton, and J. A. Githens

Boresight Cameras, K. L. Warthman

a few degrees Kelvin, any thermal radiation from the earth picked up by an imperfect antenna can represent a serious source of noise. For example, a parabolic antenna pointing at the zenith will pick up thermal noise via its side and back lobes. Back and far side lobes emanating about 10 per cent of the radiation of an isotropic or non-directional antenna will pick up a noise contribution of about 20 degrees K from the earth.

Thus, requirements for a low-noise antenna must include very low side and back lobes. Fortunately this requirement is compatible with other desirable characteristics. Such an antenna will reduce the effects of man-made interference and it will be efficient in the sense that its effective area will approximate the actual area of the aperture. In addition, the antenna and its associated feed structure must have low ohmic losses.

Horn-Feed Antenna

These requirements are satisfied to a high degree by a horn-feed parabola designed by Bell Laboratories for microwave relay applications. First used in the Bell System's TD-2 radio relay system, it has played an important part in the success of the Echo project. The radiation pattern of this antenna shows its far side lobes at about 10 per cent of an isotropic antenna while the rear lobes are at 0.1 per cent. Consequently, the total earth noise picked up by the antenna with the beam pointed vertically is less than 2 degrees K.

The amplifier used in the noise-measuring experiments is a traveling-wave maser. This is a solid-state amplifier that uses a "slow-wave structure" instead of a cavity for the signal. A comb-like structure acts to slow down the rf wave. The active gain-producing material comprising the maser is ruby.

Transmission lines leading from access terminals in the room-temperature environment to the cold maser are of material having low heat conductivity. A "K band" waveguide connects the maser to a microwave "pump." At one end of the assembly is a plate which forms a vacuum seal for the helium dewar—a container for the liquid helium needed to keep the amplifier at a low temperature.

In the middle of its tuning range (5.65 mc), the traveling-wave maser has a gain of 35 db at a bandwidth of 25 mc. This gives the amplifier sufficient gain to override the noise of a crystal mixer following it in the circuit. The maser itself has a noise temperature of 2 degrees K at its low-temperature input. The coaxial connection on the input side, however, contributes 8.5 degrees

K of noise, given the preamplifier a total noise temperature of 10.5 degrees K at the side of the amplifier in the room-temperature environment.

The throat of the horn antenna, rectangular in shape, tapers into circular waveguide which permits the antenna to rotate about the horn axis. It then tapers back to rectangular waveguide to enter the amplifier. The plumbing necessary to permit transition of the signal from waveguide to coaxial cable is attached directly to the input cable to reduce input losses. On the output side of the maser, the signal goes to an isolator, a precision attenuator, another isolator, and then to the crystal mixer, mentioned above, of a super-heterodyne receiver.

The technique for measuring sky-noise involved comparison with a known noise signal from an argon noise lamp coupled to the input waveguide via a 26-db directional coupling. When fired, the noise lamp introduces additional noise into the system equivalent to about 25 degrees K. The change in the level of the output noise is measured with a precision attenuator following the maser. First, with the noise lamp off, the precision attenuator is set to some conveniently low value of attenuation and the receiver gain is adjusted for a convenient reference level of detected noise output. Then, as the noise lamp fires, the attenuation is adjusted to give the same detected noise output as before. Knowing the excess noise

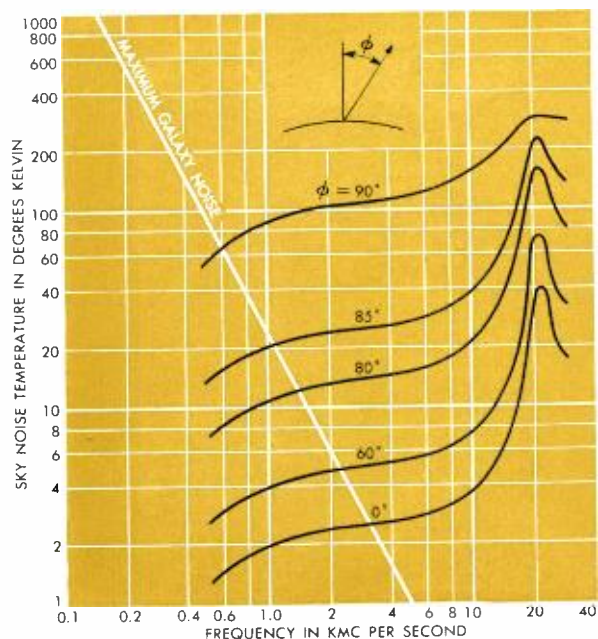

Galaxy noise decreases with increasing frequency; noise emanating from earth sources increases.

DeGrasse, E. A. Ohm, and the authors. With a high-efficiency horn-reflector antenna and low-noise maser, measurements were obtained from which it is possible to predict accurately the lowest noise "temperature" that can be achieved with present systems. It is interesting to note that this antenna-maser combination is but a scaled-down version of the one later used for the Echo satellite program.

In discussing the sensitivity of a receiving system, it is convenient to refer all sources of electrical noise to one place—where the signal enters the system. In this way the real system can be replaced by an artificial noiseless one with a noise generator at its input whose magnitude of output noise represents the total noise in the actual system. In general, the noise power can be expressed by the product of the absolute temperature of this fictitious noise source and the bandwidth of the system in cycles per second. It is then possible to refer, instead of to noise "power," to noise "temperature" which has more direct significance in a very low-noise system. Furthermore, just as noise powers can be added, so can noise temperatures. Consequently, the effective noise temperature of a system consists of the sum of the noise temperatures of its constituent components, all referred to the input.

Any earth-bound receiving system will pick up noise from the thermal radiation of the sky and this will set a lower limit to the sensitivity of such a system. This noise originates both extraterrestrially and terrestrially.

Many of the extraterrestrial sources of noise interest the radio astronomer. In most cases, however, only the sun, moon and our own galaxy constitute sources of serious interference to com-

munications, and since the sun and moon occupy only a small angle, they are easily avoided. However, the galaxy is a widespread source with varying intensity. Fortunately, this noise from the galaxy decreases with higher frequencies, and its interference contribution becomes negligible above 5 kmc.

Terrestrial noise comes from the oxygen and water vapor in the earth's atmosphere, which absorb radiation at microwave frequencies and consequently act as sources of thermal noise. This absorption, and hence the thermal radiation, also depends on frequency, but decreases with decreasing frequency, becoming on a dry day, very low *below* 5 kmc. Moreover, the effective noise temperature of the atmosphere depends on how much atmosphere the antenna beam goes through. Hence the noise temperature will vary with the elevation angle of the antenna, being a minimum when the antenna is pointed at the zenith. This angular dependence is shown in the figure on the next page.

Theoretically, then, the total sky noise (galaxy plus atmosphere) exhibits a broad minimum at about 5 kmc. This is the primary reason for performing the experiments near this frequency. Communications system connecting one point to another on earth, where signals travel parallel to the earth, will pick up about 100 degrees K noise from the atmosphere and the ground. Thus, receiving systems with noise temperatures of 20 degrees K or less are likely to find their main applications in satellite or space communications at frequencies of around 5 kmc, and where the antenna elevation is 10 degrees or more above the horizon.

Since electrical noise from the sky may be only

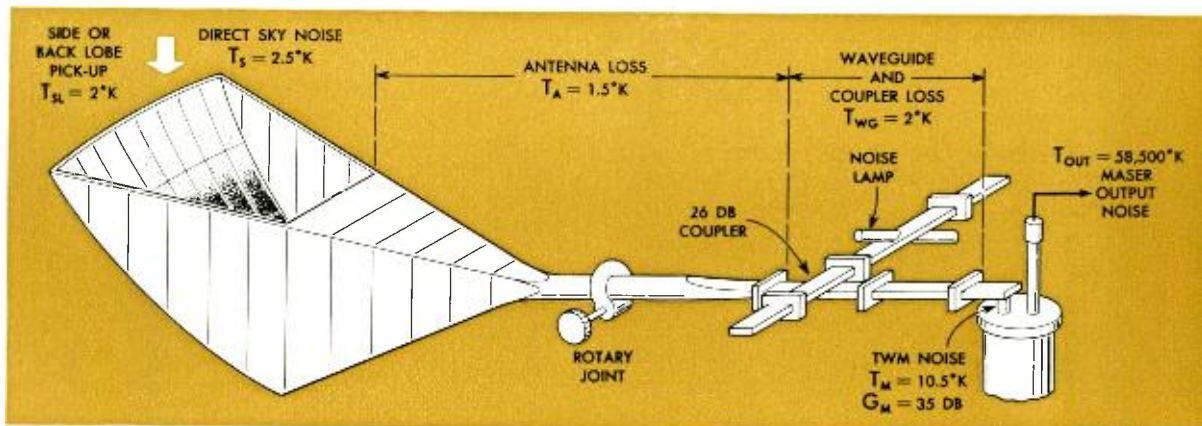

How horn-reflector antenna connects to traveling-wave maser. Cold maser is connected to rest of

equipment by low heat-conductivity lines. K-band waveguide connects the maser to microwave pump.

Research in space communications has uncovered some problems heretofore of minor interest to communications engineers. One of these is noise from the atmosphere. Studying it has required extensive research into the use of antennas and amplifiers.

D. C. Hogg and H. E. D. Scovil

Measuring the Sky's Electrical Noise

One of the great obstacles to be hurdled in designing an efficient communications system is to overcome the effects of electrical noise. Electronic devices, even when at rest, abound in noise "generators" in the form of random fluctuations of the atoms in their materials. And when these devices operate, the agitated atoms generate a great deal of noise while amplifying the signal.

Today, we want to send signals over longer and longer distances, to communicate via artificial satellites. The successful balloon-bounce experiment of Project Echo (RECORD, *September*, 1960) is but the first step in this method of transmission. Thus, it seems imperative to find ways to generate and amplify microwave signals with as little noise as possible. Fortunately for this requirement, new devices have recently arrived on the communications technology scene, such as the parametric amplifier (RECORD, *October*, 1959) and the maser (RECORD, *July*, 1958; *May*, 1960).

Heretofore, the amplifier was by far the most serious contributor of noise in a communications system operating at microwave frequencies. But the ultra low-noise devices now available direct us to examine the entire system for its separate noise contributors. Masers now being developed, for example, are so sensitive that even the transmission line connecting one to an antenna might add several times the noise intrinsic to the maser. Furthermore, the antenna, the antenna feedhorn, and even the sky itself become important contributors.

Before any disease can be cured, it must first be diagnosed. Similarly, to learn the abilities of a long-range communications system, such as provided by artificial satellites, we first need to learn about the inherent noise in the system. For this reason, a series of noise measurements was conducted on top of Crawford Hill, near the Holmdel, N. J. location of the Laboratories, by R. W.

with its wrapped tape is easily produced in long lengths, which are simply cut to size for assembly into an array. Also, in reading out a bit, the reversal of the magnetic flux has a transformer action, since the magnetic flux wraps around the center copper conductor several times. A small interrogating voltage produces a larger output voltage. And, like core memories, the twistor is a high-speed device which can store large amounts of information compactly. In such a twistor memory four bits are usually stored per inch of wire.

In a variation of this device, a twistor becomes the sensing circuit. The actual information is stored in an array of small bar magnets mounted in a card. That is, at each point in the X-Y coordinates, there is a choice of placing a magnet on the card or of omitting it. If a magnet is placed at a coordinate position, its external field inhibits the switching of the twistor segment. Thus, applying currents to the twistor in effect interrogates the data stored on the card. When the segment cannot be switched, this indicates a magnet on the card; switching indicates no magnet. The structure is a non-destructive memory, and might be called a "card-changeable" device. Small cards of magnets may be removed and inserted in somewhat the same manner as that used with photographic plates in the flying-spot store. The use of many magnet cards may make the capacity of the memory comparable to that of the flying-spot store.

To this point, electronic memories have been described in terms of magnetism, electrostatic storage, and photographic exposures. But these, of course, by no means exhaust the physical phenomena that could be used to write, interrogate and read out communications information. Three additional possibilities will be mentioned briefly here. The first is a variation on the idea of the flying-spot store. Instead of the screen of a cathode-ray tube, we might use an electroluminescent screen with a matrix of wires on both sides. Applying signals to two of the wires would then generate an electroluminescent spot at an X-Y position defined by the intersection of the two wires.

Ferroelectric materials have also been investigated for use in memory systems. When a voltage is applied to a ferroelectric crystal, the surface of the crystal accumulates an electrostatic charge. Since the phenomenon here is analogous to a change in magnetic flux, the proposed methods of using ferroelectrics are quite similar to



Lee H. Gallaher, Electronic Central Office Development Department, adjusts lenses on servo system of experimental flying spot store memory.

those for which magnetic materials are used.

Another memory technique now under investigation is the phenomenon of superconductivity. Certain metals, when refrigerated to temperatures near absolute zero, lose all their electrical resistance. Further, with the application of a magnetic field, they can be rapidly switched between this superconducting state and the state of normal conductivity. Devices based on this phenomenon, called "cryotrons," can store very large amounts of information in a small space, and their switching speed is very fast. Refrigerating to extremely low temperatures is a problem for some applications, but this should become less serious as low-temperature technology advances.

All the devices discussed in this article have been referred to several basic requirements of electronic switching. Work has been directed toward temporary and permanent memories, and toward reading the information either serially or in parallel. The concept of random access to the stored data is also important. Further, the emphasis is on very small pieces or segments of memory materials and on very high switching speeds. Ultimately, such requirements are aimed at the design of the communications systems of the future—equipment that will occupy only a small amount of floor space but will perform existing services better, and with a greatly increased capacity at the lowest possible cost.

Y row. These two half-currents are insufficient to switch the cores in either the column or the row, except for the particular core at the one X-Y point which receives both currents. This core then reverses its direction of magnetization. In reading this bit out of the core, coincident currents are similarly used. If the two half-currents are impressed on a core that is already in the magnetic state that would be produced by these currents, little change results. But if the core is in the opposite state, the core is switched, and the consequent reversal of flux induces a voltage pulse in a "sensing" wire. Read-out thus consists of sensing the pattern of voltages and no-voltages from the memory.

For this type of storage, it is evident that the two directions of magnetization must be unambiguous. In magnetic terms, this means that the hysteresis loop of the magnetic material should be rectangular with a well defined "knee." Magnetic fields below the knee or threshold should produce no switching, while fields slightly larger than the knee should completely reverse the magnetic flux. After the currents are removed, the flux density should stabilize at a remanent induction not too much less than saturation. Various ferrite materials (RECORD, April, 1957) have been particularly useful for such applications.

It is also evident that with this type of core arrangement, the act of reading the information removes it from the memory. Read-out is "destructive," and the memory is termed "erasable." For this reason, a number of variations have been tried for applications where a non-destructive

memory is desired. In some, the memory is designed to be regenerative. Since the output circuits know what *was* in the memory, it is a fairly straightforward procedure to put it back in again after a readout.

In another variation, the "transfluxor," each core not only has the main or central hole for storage but also has another smaller hole through its wall. Wires passing through these smaller holes can detect the presence of stored information without changing the magnetic state of the large hole. A memory constructed with such cores is a non-destructive readout memory. In still another variation, the "inhibited fluxor," small pieces of ferrite have three holes each. Wires through two of the holes are used for reading and writing while the flux change around the third hole is sensed. Information may be written into the core by the coincidence of currents in the two holes. The inhibited fluxor can be switched at extremely high speeds using fairly simple schemes for selecting the points of storage.

The Twistor Memory

The search for new and improved memories has led to a new device known as the "twistor"—another relative of the magnetic-core memory, but one that has no cores. Its basic principle of operation is that a circular magnetic field produced by a current in the wire and a linear magnetic field applied externally combine to produce a helical magnetization.

In one form of twistor, a small magnetic tape is wrapped helically around a copper conductor. Unlike the core memory, in which the magnetic flux is wrapped around itself in closed ring, the twistor has its magnetization along a length of the wrapped material—over several turns of the tape. Thus, successive bits are stored along a length of twistor wire. The circular magnetic field is produced by a current through the copper conductor, and the linear field is produced axially by a coil surrounding the particular segment to be magnetized. The method of inserting a bit bears some similarity to the method used in the core memory: a circular field from the current in the copper conductor, by itself, is not sufficient to switch the magnetic flux in a segment of tape. Neither is the current in the coil producing the axial field. Where the two coincide, however, the segment of magnetic tape is magnetized by the resultant field.

The twistor structure has a number of advantages. In particular, the copper conductor

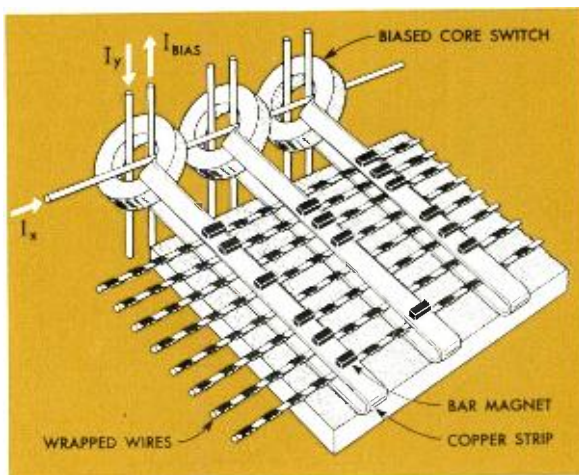

Section of twistor magnet memory with three cores and word coils, intersecting eight twistors.

A new concept in automatic manufacture of electronic components combines statistical quality control with mechanized processing at the Western Electric Company.

Resistors for Nike-Zeus Made On a Completely Automated Line

Carbon deposited resistors—untouched by human hands—are being turned out at the rate of one every three seconds by a unique computer-controlled production line. The 110-foot long facility, recently shown for the first time, was developed by Western Electric Company's North Carolina works to meet stringent military requirements for the Nike-Zeus anti-ICBM.

The heart of the resistor is a tiny ceramic core produced from processes developed by Bell Laboratories. Fed automatically from a hopper at the beginning of the line, the core moves along a conveyor belt to the coating machine at a speed controlled to within an accuracy of 0.1 per cent.

News of The Bell System

The line, which Western Electric explained is the first completely automated process to manufacture any discrete electronic component, consists of eleven stations, all tied into control by a general purpose computer. Feedback of process data from three key points along the line permits rapid closed-loop operation.

The process begins with the deposit of carbon on the ceramic core. The core then goes successively through inspection, termination, capping, spiralling to value, second inspection, molding of a protective case, marking, leak inspection, final inspection and packing.

At the coating machine, a control device regulates the speed of the core through the three separate chambers of a horizontal furnace. A horizontal three-roller support system rotates it en route to assure a uniform coating. In the heating areas of each chamber, a temperature of over 2000 degrees F. decomposes methane gas to form crystallizing carbon on the core. After cooling, the core is sent to an inspection station.

The first inspection station forms a feedback loop from the coating furnace through the computer. Here the coated core passes between four probes using the Kelvin bridge principle. The results of this inspection, after being measured against the programmed requirements, form the basis for feedback control of the furnace.

The core next goes to a terminating machine which sputters a gold contact over each end. First, it is fitted with a mask which holds and protects its center. (The computer programs proper mask sizes for four different sizes of resistors.) The mask is loaded onto a vacuum station and covered with a bell jar. After the jar is pumped to a vacuum and backfilled with argon gas, the ends of the core protruding from the mask are sputtered with particles from a gold cathode. The sputtering lasts for almost a minute, depositing a layer of gold approximately ten millionths of an inch thick.

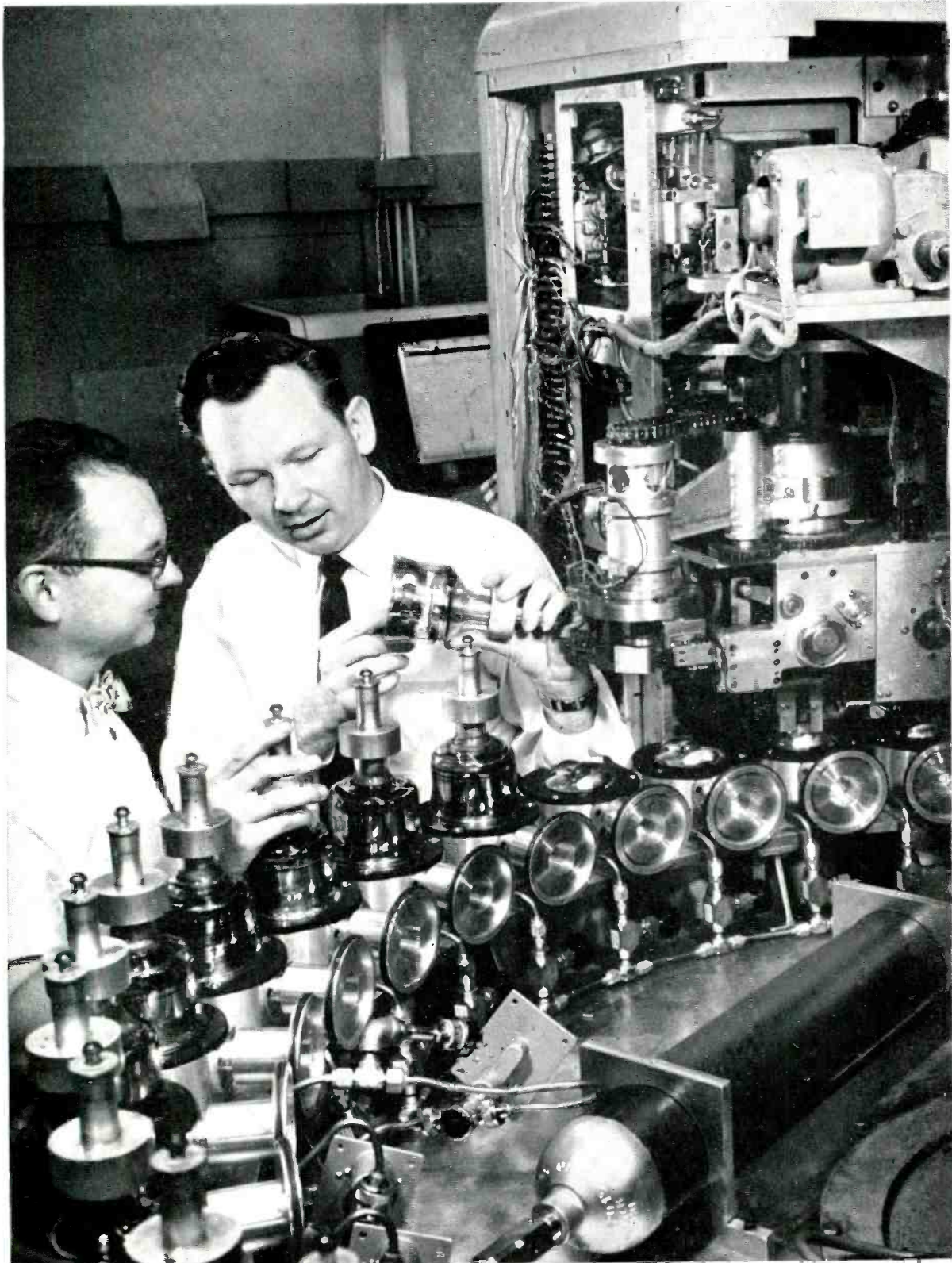

Western Electric engineers inspect computer-controlled terminating machine in the automatic

production line. Cathodes in bottom of each bell jar sputter layers of gold on ends of resistor cores.

At this point, the ceramic core is a resistor. The capping station now attaches wire leads to each end. The wire leads are first attached to tiny hexagonal caps of gold-plated brass by an automatic percussion welding machine outside the line. The capping machine uses two different capping assembly heads and three different sizes of caps for the four resistor wattage sizes. The computer controls both the switching of the assembly heads and the changing of the cap sizes.

The helixing machine, the next station on the line, gives the resistor a precise value. To do this, it cuts a spiralled groove along the carbon film of the core by rotating the properly-chucked resistor against a diamond-impregnated wheel. A computer-controlled bridge monitors the cutting. The bridge's control servos balance when the desired resistance is reached. During cutting, the bridge also senses any chipped or unevenly coated cores and rejects them. It also rejects any resistor that reaches value before 75 per cent of its length is used or fails to reach value in its full length. The helixing is done "dry" and continues until final resistor value is reached; this eliminates the hand-rubbing final adjustment method previously used.

The feedback control and self-correction of the helix lathe bridge is based on a statistical quality control analysis of values inspected at the second inspection station. A wheatstone bridge, set to the desired nominal resistance value of each resistor lot by the computer, precisely measures the resistance. Off-balance voltage is digitized and fed back to the computer, which then calculates the desired correction and adjusts the helixing machine setting.

The resistor is then fitted with a precured epoxy shell and two partially cured epoxy pellets and placed between two resilient rubber chucks before it enters the encapsulating machine. The resilient chucks prevent trapped air from causing leaks in the finished resistor.

After they are cured for about 15 minutes in a 300 degree F oven, the partially cured pellets soften and form an effective seal with the precured shell. To terminate the curing process, the resistors are passed through cooling water jets. Detection circuits within the machine reject any resistors with missing shells or missing pellets.

Moving along the conveyor belt from the oven, the resistor is immersed in a hot water bath which contains a wetting agent. This prevents surface bubbles from clinging to the resistor body. The heat expands the air inside the capsule, and a series of ten photoelectric cells watch for air bubbles which would indicate a leak.

A computer controlled marking machine now

stamps the wattage, resistance value, production lot number and date on the encapsulated resistor. Servo drives controlled by the computer can set any one of 45 different code numbers with over a million and a half permutations of code and resistance value combinations.

The final inspection station, a feedback control point, resets the preceding inspection station to compensate for shifts in resistance value caused by the heat of encapsulation.

The acceptable resistors are then packed in lots by the packing machine and inserted into styrofoam blocks—the final process in this fully automatic operation.

The heart of the control equipment, the digital computer, has an over-4000-word magnetic-drum memory. Western Electric engineers extensively redesigned its input and output circuits to control the programming, setup and feedback control of the individual machines. To produce resistors with four different wattages and a huge number of resistance values the computer performs four basic functions:

- ▶ It programs production requirements for a month, completely scheduling and arranging the work according to the power sizes and resistor values to be produced.
- ▶ It analyzes control statistically from data plotted at three critical points in the automated process and determines if a trend is developing.
- ▶ It formulates information to detect any drift from manufacturing tolerances and, if such a drift develops, calculates new setup information for the appropriate station from previously stored data.
- ▶ It provides the initial setup of wattage size at eight machines and resistance value at six.

In missile systems, deposited carbon resistors are required by the millions and they must work under extreme conditions of cold, heat, humidity, vibration and shock. In certain defense equipment, a failure rate of no more than one per 200 million hours—about 23,000 years—of operation is permissible.

This reliability requirement is mainly responsible for the development of the automatic line. Until now, individual precision products have been made by manual or semi-automatic processes and they were subject to contamination from handling and other shortcomings of human control. With advanced automation, there is no contamination problem, production is vastly increased and a level of reliability is attained that manual methods cannot match.

Trial Begins On PCM Transmission System

A major advance in telephone transmission called pulse code modulation, or simply PCM, was put on trial early last month over Bell System customer's telephone lines between Newark and Passaic, New Jersey. The experimental PCM system, the T1 system, was developed by the Laboratories at Murray Hill and Merrimack Valley.

The T1 system does not send a continuous voice signal as do conventional systems. Instead, it takes samples of the speaker's voice very rapidly—about 8,000 samples a second—encodes them and sends out code pulses. At intervals of approximately 6,000 feet along the cable route, the coded signals are regenerated and sent on to the next repeater point. At the other end the pulses are decoded and the original voice signal is reconstructed.

The system sends pulses over a cable pair at the rate of one and one-half million pulses per second. This rate permits the codes of many different voices to be interlaced on the same wires, thus increasing their message-carrying capacity.

The T1, forerunner of PCM systems that may eventually stretch across the country, was designed to serve metropolitan area routes of up to 25 miles. Other systems that increase the message capacity of wires and cable have been used for many years by telephone companies, but they have been economically feasible only over fairly long routes.

The new system is expected to be particularly useful in large cities like New York, where congestion below ground has often made it difficult to find room for additional telephone conduits. To increase telephone facilities along a route, telephone companies will not have to dig up city streets. Instead, they may increase the capacity of their existing cables by installing T1 terminals in telephone buildings at each end of the route, and T1 repeater equipment in manholes or on poles along the way.

Starting early next year, Western Electric Company will manufacture T1 for general use throughout the Bell System.



H. E. Brown, above, and M. S. Coldenhoff check out T1 System equipment in a Newark, N. J. manhole.

news in brief

A. L. Stott Elected A.T.&T. Vice-President

Alexander L. Stott, A.T.&T. comptroller was recently elected a vice-president of the company.



A. L. Stott

Mr. Stott joined the Bell System in 1929 as a clerk in A.T.&T.'s chief statistician's division. Later he became supervisor of toll studies in the Long Lines Department and following that, staff assistant in the Treasury Department. He was appointed assistant comptroller in 1949 and assistant treasurer in 1952. He was elected treasurer of A.T.&T. in December 1952 and comptroller in the following year.

Mr. Stott received his A.B. degree from Harvard University in 1929. He served with the U.S. Navy from 1942 to 1945 and attained the rank of commander. He is a trustee of the Committee for Economic Development, a member of the Controllers Institute of America and a vice president of the New York City Control.

Announcement System Makes New York Debut

The 9A Announcement System, developed at Bell Laboratories (RECORD, February, 1959) was recently put in service for the New York City Report. The report consists of a one-minute recorded message on matters of general municipal interest. In emergencies, such as transit tie-ups, fires and severe weather conditions, bulletins will keep New Yorkers posted on up-to-the-minute conditions. The message is recorded at a master control center and fed first to a Manhattan central office and then through a network of direct telephone trunk lines to central office sub-centers in other boroughs.

The service, similar to the telephone company's time and weather announcements served by the 3A Announcement System (RECORD, November, 1939), was bought by the city because police, transit and other city information channels were overloaded during Hurricane Donna last fall.

New Building for Crawford Hill

The Laboratories has announced plans for the construction of a one-story laboratory building on its Crawford Hill property in Holmdel. Construction will begin this summer and plans are for the building to be completed in early 1962, at the same time the new development center off Crawford-Everett Road is opened.

The new building will replace the existing frame structures in front of the development center. These frame buildings are a research outpost which began in 1929; they will be razed to make room for site grading and roads at the new center.

The new building will be of masonry, and will have two one-story sections connected by a wing. It is planned to accom-

modate about 120 people who are now working in the old frame structure.

The old buildings were a center of research in radio and

waveguide science. It was at this site that Karl Jansky did his memorable work on the world's first "radio telescope." The scientists and engineers who will move to the new building will continue their radio and waveguide research there.

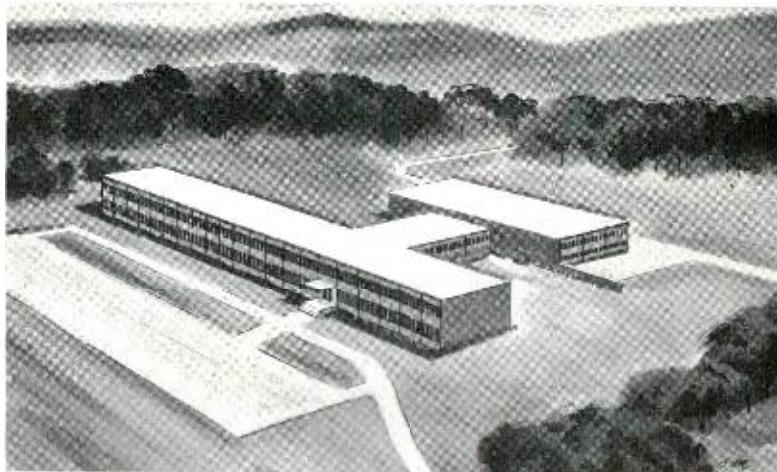

Artist's sketch of the proposed new building for Crawford Hill.

TALKS

Following is a list of speakers, titles and places of presentation for recent talks presented by members of Bell Laboratories.

SEMICONDUCTING COMPOUNDS CONFERENCE, Schenectady, New York.

- Dietz, R. E., and Thomas, D. G., *Excitons and Absorption Edge of ZnO*.
- Hutson, A. R., *Piezoelectricity and Semiconductivity in Wurtzite and Zinc Blende Semiconductors*.
- Morin, F. J., *Halides, Oxides, and Sulfides of the Transition Metals*.
- Thomas, D. G., *Excitons and Band Splitting in CdTe*.
- Thomas, D. G., see Dietz, R. E.

SYMPOSIUM ON MOLECULAR STRUCTURE AND SPECTROSCOPY, Ohio State University, Columbus, Ohio.

- Adamson, A. W., see Liehr, A. D.
- Liehr, A. D., *The Three Electron (or Hole) Cubic Ligand Field Spectrum*.
- Liehr, A. D., Perumareddi, J. R., and Adamson, A. W., *Spectra of the One and Two Electron (or Hole) Transition Metal Cyanide Complexes*.
- Perumareddi, J. R., see Liehr, A. D.
- Porto, S. P., and Wood, D. L., *The Optical Maser as a Raman Source*.
- Snyder, L. C., *The Interaction of Pi Electrons with C-C Bond Length Displacements in Pseudaromatic Molecules*.
- Wood, D. L., *Electronic Spectra of Divalent Rare Earth Ions in CaF₂*.
- Wood, D. L., see Porto, S. P.

OTHER TALKS

- Anscombe, F. J., *Testing to Establish a High Degree of Safety or Reliability*, Inst. Math. Statistics Eastern Regional Meeting, Ithaca, N. Y.

- Bennett, W. R., Jr., *Radiative Lifetimes and Collision Transfer Cross-Sections of Excited Atomic States*, Quantum Electronics Conf., Berkeley, Calif.
- Bennett, W. R., Sr., *Recent Trends in Communication*, Weekly Colloquium Elec. Engg. Depart., University of Minnesota, Minneapolis, Minn.
- Bhuta, P. G., *Nonsteady Two-Dimensional Jet Mixing Theory for Laminar and Turbulent Flows*, Stevens Institute of Technology, Hoboken, N. J.
- Bird, C. M., see Flanagan, J. L.
- Brattain, W. H., *Brattain on Semiconductors*, The Norfolk College of William and Mary, Norfolk, Va.; Sigma Xi Lecture, Stevens Institute of Technology, Hoboken, N. J.
- Brattain, W. H., *Seminar on the Surface Properties of Semiconductors*, Chem. & Phys. Faculty, The Norfolk College of William and Mary, Norfolk, Va.
- Collins, R. J., *Optical Maser*, Optical Soc. Am., Chicago, Ill.
- Connolly, R. A., see DeCoste, J. B.
- Courtney-Pratt, J. S., *A Note on the Possibility of Photographing a Satellite Near the Moon*, The Ultimate Sensitivity in Photography Conf., London, England.
- David, E. E., Jr., see Flanagan, J. L.
- DeBenedictis, T., see Hansen, R. H.
- DeCoste, J. B., and Connolly, R. A., *Plastics Versus the Elements*, Soc. of Plastics Ind. Meeting, N. Y. C.
- Deutsch, M., *Bargaining 'Face': Some Experiments in Bargaining Behavior*, Nineteenth National Meeting of Operations Res. Soc. Am., Chicago, Ill.
- Elkind, M. J., *Gold-Plating Electron Devices*, Western Electric Interworks Finishers Conf., Columbus, Ohio.
- Engelbrecht, R. S., *Elementary*

- Considerations of Noise Performance*, I.R.E. PGMT&T National Symposium, Wash., D. C.
- Felder, H. H., and Osgood, D. T., *A Large Scale Four-Wire Switched Communications Network for Military Communications—The Transmission Plan*, Fifth National Symposium on Global Communications, Chicago, Ill.
- Flanagan, J. L., and Bird, C. M., *Minimum Phase Responses for the Basilar Membrane*, Sixty-First Meeting of Acous. Soc. Am., Phila., Pa.
- Flanagan, J. L., David, E. E., Jr., and Watson, B. J., *Binaural Lateralization of Cophasic and Antiphase Clicks*, Sixty-First Meeting of Acous. Soc. Am., Phila., Pa.
- Fulda, S. M., *Some Aspects of Systems Engineering in Industry*, Air Force Cambridge Res. Labs., Bedford, Mass.
- Georgopoulos, S. G., *5 Type Artificial Larynx*, Irvington Sertoma Club, Indianapolis, Ind.
- Germer, L. H., *Low Energy Electron Diffraction Studies of Adsorbed Gases*, Phys. Colloquia, Rutgers University, New Brunswick, N. J.; Res. Depart., United States Steel Corp., Monroeville, Pa.
- Gianola, U. F., Looney, D. H., Mum, A. J., and Ruff, J. A., *Large Capacity Card-Changeable Permanent Magnet Twistor Memory*, Symposium on Large Capacity Memory Techniques, Wash., D. C.
- Gibbons, D. F., *Magneto Acoustic Measurements of the Fermi Surface of Zinc and Cadmium*, Princeton University, Solid State Colloquium, Princeton, N. J.
- Gibson, W. M., *Structure in the Kinetic Energy Spectrum of Fragments from the Thermal-Neutron-Induced Fission U²³⁵*, Oak Ridge National Lab., Oak Ridge, Tenn., Los Alamos Scientific Lab., Los Alamos, N. M.

- Gibson, W. M., and Miller, G. L., *Charge Collection in Semiconductor Particle Detectors*, Nuclear Electronics Conf., Belgrade, Yugoslavia.
- Glaser, J. L., *Radio Communications via Satellites*, Wichita, Kan.; St. Louis, Mo.; Cincinnati, Ohio.
- Glaser, J. L., *The Planning of Commercial Satellite Communication Systems*, Chicago, Ill.
- Gnanadesikan, R., *Graphical Analysis of Multi-Response Experimental Data Using Ordered Distances*, I.M.S. Meetings, Seattle, Wash.
- Hansen, R. H., and DeBenedictis, T., *Studies of the Decomposition of Blowing Agents. I: A Method for Predicting Performance*, Am. Chem. Soc., Seton Hall University, South Orange, N. J.
- Haugk, G., see Hoover, C. W.
- Hayes, J. S., *Electron Beam Microanalyzer, New Tool for Electron Device Development*, A.S.T.M., Phil., Pa.
- Hight, S. C., and Kreer, J. G., Jr., *Some Studies of Special Orbital Configuration for Global Communications*, A.I.E.E./I.R.E. GLOBECOM V Conf., Chicago, Ill.
- Hoover, C. W., and Haugk, G., *The Flying Spot Store*, Large Capacity Memory Techniques for Computing Systems Symposium, Wash., D. C.
- Kaiser, W., *The Optical Maser*, Fifteenth Annual Frequency Control Symposium, Atlantic City, N. J.
- Kometani, T. Y., *Determination of Sodium Fluoride in Wood*, Am. Wood Preserver's Assoc., Banff, Canada.
- Kreer, J. G., see Hight, S. C.
- Leutritz, J., Jr., *The Dimethylformamide (DMF) Extractables in Steam-Conditioned Pine*, Am. Wood Preserver's Assoc., Banff, Canada.
- Lewis, W. D., *The Impact of Communication Technology on Computer Technology and Vice Versa*, Information Processing & Computer Technology Symposium, Bendix Corp. Res. Labs. Div., Southfield, Mich.
- Linder, S. L., *Improved Performance from Matrix Electroluminescence Screens in Optical Readout Applications*, Large Capacity Memory Techniques for Computing Systems Symposium, Wash., D. C.
- Looney, D. H., see Gianola, U. F.
- Matthias, B. T., *Ferromagnetism and Superconductivity*, IBM Conf. on Superconductivity, Yorktown Heights, N. Y.
- McLean, D. A., *American Development in Miniature Capacitors*, I.E.E. Symposium, London, England.
- Miller, G. L., see Gibson, W. M.
- Miller, L. E., *Reliability of Silicon Transistors and Diodes*, Advisory Gp. on Electron Tubes Conf. on Reliability of Semiconductor Devices, N. Y. C.
- Moore, E. F., *Machine Models of Self-Reproduction*, RCA Labs., Princeton, N. J.
- Mum, A. J., see Gianola, U. F.
- Osgood, D. T., see Felder, H. H.
- Pfann, W. G., *New Ways of Using the Piezoresistance of Semiconductors to Measure Stresses or Strains*, University of Illinois, Dept. of Mining & Metallurgy, Urbana, Ill.
- Pfann, W. G., and Thurston, R. N., *Semiconductor Stress Transducers Utilizing the Transverse and Shear Piezoresistance Effects*, Am. Phys. Soc., Wash., D. C.; University of Pennsylvania, Metallurgy Depart. Colloquium, Phil., Pa.
- Pierce, J. R., *Research and Technology in the Space Age*, Fourth Annual Alumni Seminar, University of Kentucky, Lexington, Ky.
- Pierce, J. R., *What Computers Can Do Better—And How*, M.I.T. Centennial Lecture Series, Cambridge, Mass.
- Pierce, J. R., *What We Should Do About Satellite Communication Now*, First National Conf. on Peaceful Uses of Space, Tulsa, Okla.
- Ruff, J. A., see Gianola, U. F.
- Schawlow, A. L., *Infrared and Optical Masers*, Conf. on Atomic Spectra, Argonne National Lab., Argonne, Ill.
- Schroeder, M. R., *Further Progress with Colorless Artificial Reverberation*, Sixty-First Meeting of Acous. Soc. Am., Phila., Pa.
- Schwartz, N., *Tantalum Thin Film Components and Integrated Circuitry*, I.R.E. Prof. Gp. on Component Parts, Wash., D. C.
- Smith, W. L., see Spencer, W. J.
- Spencer, W. J., and Smith, W. L., *Precision Crystal Frequency Standards*, Frequency Control Symposium, Atlantic City, N. J.
- Tebo, J. D., *The Nike Missile Family*, Old Guard, Summit, N. J.
- Tebo, J. D., *Satellite Communication and Project Echo*, Rotary Club, Elizabeth, N. J.
- Thurston, R. N., see Pfann, W. G.
- Trumbore, F. A., *Problems in Semiconductor Crystal Growth*, Phys. Chem. Sem., University of Pittsburgh, Pittsburgh, Pa.
- Tukey, J. W., *The Future of Data Analysis*, Twenty-Fourth Annual Meeting of Inst. of Math. Statistics, Seattle, Wash.
- Walsh, W. M., *Magnetic Resonance in Nucleic Acid Samples*, A. D. Little Co., Cambridge, Mass.
- Walters, K. R., *Similarities of the Human Nervous System and Our Communications Network*, Princeton University, Department of Psychology, Princeton, N. J.
- Watson, B. J., see Flanagan, J. L.
- White, D. L., *Depletion Layer Transducer—A New High Frequency Ultrasonic Transducer*, I.R.E. National Conv., N. Y. C.
- Williams, W. H., *Remarks on the Efficiency of Unbiased Estimation with Auxiliary Variates*, I.M.S. Meeting, Seattle, Wash.
- Wintringham, W. T., *The Principles of Color Television*, Thirtieth Annual Meeting of Inter. Soc. Color Council, Rochester, N. Y.
- Wright, J. P., *Chemistry and Your Telephone*, Rotary Club, Greenville, Tex.
- Yokelson, B. J., *Electronic Switching System*, A.I.E.E., N. Y. C.
- Zacharias, A., *A Precise Method for Measuring the Incremental Phase and Gain Variations of a Traveling-Wave Tube*, 1961 I.R.E. International Meeting, N. Y. C.

PAPERS

Following is a list of the authors, titles, and places of publication of recent papers published by members of the Laboratories.

- Adler, R., see Engelbrecht, R. S.
 Alburger, D. E., see Donovan, P. F.
 Allen, F. G., *Field Emission from Silicon and Germanium: Field Desorption and Surface Migration*, The Phys. & Chem. of Solids, 19, pp. 87-99, 1961.
 Aloisio, C. J., *A Low Temperature Ultraviolet Cell*, Rev. Sci. Instr., 32, p. 452, Apr., 1961.
 Ashkin, A., *A Low-Noise Microwave Quadrupole Amplifier*, Proc. I.R.E., 49, pp. 1016-1020, June, 1961.
 Ashkin, A., see Gordon, E. I.
 Bateman, T., Mason, W. P., and McSkimin, H. J., *Third Order Elastic Moduli of Germanium*, J. Appl. Phys., 32, pp. 928-936, May, 1961.
 Bozorth, R. M., Wolff, P. A., Davis, D. D., Compton, V. B., and Wernick, J. H., *Ferromagnetism in Dilute Solutions of Cobalt in Palladium*, Phys. Rev., 122, pp. 1157-1160, May 15, 1961.
 Brown, W. L., *Properties of Space Charge Regions*, Semiconductor Nuclear Particle Detectors Publication 871, National Academy of Sciences, National Research Council, Wash., D. C., pp. 9-18, 1961.
 Buck, T. M., *Surface Effects on Silicon Particle Detectors*, Proc. Asheville Conf. on Semiconductor Nuclear Particle Detectors, 871, National Academy of Sciences, National Research Council, pp. 111-120, 1961.
 Burrus, C. A., *Gallium Arsenide Esaki Diodes for High Frequency Applications*, J. Appl. Phys., 32, pp. 1031-1036, June 1961.
 Burrus, C. A., *Gallium Antimonide Esaki Diodes for High Frequency Applications*, Proc. I.R.E., 49, p. 1101, June, 1961.
 Burrus, C. A., *High-Frequency Silicon Varactor Diodes*, J. Appl. Phys., 32, pp. 1166-1167, June, 1961.
 Burrus, C. A., and Trambarulo, R. F., *A Millimeter Wave Esaki Diode Amplifier*, Proc. I.R.E., 49, pp. 1075-1076, June, 1961.
 Compton, V. B., see Bozorth, R. M.
 Davis, D. D., see Bozorth, R. M.
 Donovan, P. F., "Recipes" for Detector Fabrication "Paint-on Particle Detectors (Recipe No. 2)", Semiconductor Nuclear Particle Detectors National Academy of Sciences, National Research Council, 871, pp. 268-269, 1961.
 Donovan, P. F., Alburger, D. E., Pixley, R. E., and Wilkinson, D. H., *Beta-Decay of N^{16} : Conservation of Spin and Parity in O^{16}* , Phil. Mag., 6, pp. 171-174, Jan., 1961.
 Doleiden, F. H., see Fuller, C. S.
 Egerton, L., see Van Uiter, L. G.
 Engelbrecht, R. S., Adler, R., Haus, H. A., Lebenbaum, M., and Mumford, W. W., *Elementary Considerations of Noise Performance*, PGMT&T National Symposium Digest, 1, pp. 53-57, May 15, 1961.
 Frisch, H. L., see Lundberg, J. L.
 Fuller, C. S., and Doleiden, F. H., *The Ionization Behavior of Donors Formed from Oxygen in Germanium*, The Phys. & Chem. of Solids, 19, pp. 251-260, May, 1961.
 Gibson, W. M., *Grown Oxide Edge Protection of p-n Junction Radiation Detectors*, Proc. of Asheville Conf. on Semiconductor Radiation Detectors, National Academy of Sciences, National Research Council, 871, pp. 232-233, 1961.
 Golden, R. M., and Schroeder, M. R., *Discussion of "Combined AM and FM for a One-Sided Spectrum"*, Proc. I.R.E., 49, p. 1094, June, 1961.
 Gordon, E. I., and Ashkin, A., *Energy Interchange Between Cyclotron and Synchronous Waves in Quadrupolar Pump Fields*, J. Appl. Phys., 32, pp. 1137-1144, June, 1961.
 Guggenheim, H. J., *The Preparation of Single Crystals of Certain Transition Metal Fluorides*, J. Phys. Chem., 64 pp. 938-939, July, 1960.
 Haus, H. A., see Engelbrecht, R. S.
 Hellman, M. Y., see Lundberg, J. L.
 Ingram, S. B., *Scientific and Engineering Manpower—The Immediate Problem and Suggested Solutions*, Elec. Engg., 80, pp. 341-345, May, 1961.
 King, B. G., see Sharpe, G. E.
 Kisliuk, P. P., *The Reflection of Slow Electrons from Tungsten Single Crystals, Clean and with Adsorbed Monolayers*, Phys. Rev., 122, pp. 405-411, Apr. 15, 1961.
 Kitsopoulos, S. C., and Kretzmer, E. R., *Computer Simulation of a Television Coding Scheme*, Proc. I.R.E., 49, pp. 1076-1077, June, 1961.
 Klockow, D. H., *Coupling Network for an Esaki Diode Transmission Amplifier*, Northeastern University, B.L.E.P. Program, pp. 1-45, Mar., 1961.
 Kluver, J. W., *Parametric Coupling Between the Transverse Waves on o- and M-Type Beams*, J. Appl. Phys., 32, pp. 1111-1114, June, 1961.
 Knab, E. D., *Synchronic Index of Gear Trains*, Prod. Engg., 32, pp. 35-39, May 29, 1961.
 Kretzmer, E. R., see Kitsopoulos, S. C.
 Lebenbaum, M., see Engelbrecht, R. S.
 Lundberg, J. L., Hellman, M. Y., and Frisch, H. L., *An Experimental Study of Polymer Polydispersity by Viscometry*, J. Poly. Sci., 46, pp. 3-17, Sept., 1960.
 Mason, W. P., see Bateman, T.
 McSkimin, H. J., see Bateman, T.
 Meiboom, S., Loewenstein, A., and Fraenkel, G., *Protonation in N-methylacetamide*, J. Phys. Chem., 65, pp. 700-702, Apr., 1961.

- McSkimin, H. J., *Notes and References for the Measurement of Elastic Moduli by Means of Ultrasonic Waves*, J. Acous. Soc. Am., 33, p. 606, May, 1961.
- Miller, G. L., *Diffused Junction Detectors*, Semiconductor Nuclear Particle Detectors National Academy of Sciences, National Research Council, 871, pp. 19-27, 1961.
- Monforte, F. R., Swanekamp, F. W., and Van Uitert, L. G., *An R. F. Technique for Pulling Oxide Crystals without Employing a Crucible Susceptor*, J. Appl. Phys., 32, p. 959, May, 1961.
- Mumford, W. W., see Engelbrecht, R. S.
- Pierce, J. R., *The Hazardous Course of Communications Satellites*, Bull. Atomic Sci., XVII, pp. 181-185, May-June, 1961.
- Piksis, A. H., see Schawlow, A. L.
- Pixley, R. E., see Donovan, P. F.
- Rich, A., see Shulman, R. G.
- Rudsill, J. A., Jr., *Servos Can Be Designed Corner by Corner*, Electronic Design, pp. 32-35, May 24, 1961.
- Sansalone, F. J., and Spencer, E. G., *Low Temperature Microwave Power Limiters*, PGMTT, 9, pp. 272-273, May, 1961.
- Schawlow, A. L., Piksis, A. H., and Sugano, S., *Strain-Induced Effects on the Degenerate Spectral Line of Chromium in MgO Crystals*, Phys. Rev., 122, pp. 1469-1476, June 1, 1961.
- Schroeder, M. R., see Golden, R. M.
- Sharpe, G. E., and King, B. G., *Low Gain, Wide Band Esaki Diode Amplifiers*, International Solid State Circuits Conf. Digest, pp. 98-99, Feb., 1961.
- Shulman, R. G., Rich, A., Walsh, W. M., Jr., Williams, H. J., and Wright, J. P., *Ferromagnetic Resonance in DNA Samples*, Biochem. & Biophys. Res. Comm., V, pp. 52-56, 1961.
- Spencer, E. G., see Sansalone, F. J.
- Sugano, S., see Schawlow, A. L.
- Swanekamp, F. W., see Monforte, F. R.
- Trambarulo, R. F., see Burrus, C. A.
- Van Uitert, L. G., and Egerton, L., *Bismuth Titanate—A Ferroelectric*, J. Appl. Phys., 32, p. 959, May, 1961.
- Van Uitert, L. G., see Monforte, F. R.
- Walsh, W. M., Jr., see Shulman, R. G.
- Wernick, J. H., see Bozorth, R. M.
- Wilkinson, D. H., see Donovan, P. F.
- Williams, H. J., see Shulman, R. G.
- Wolff, P. A., see Bozorth, R. M.
- Wright, J. P., see Shulman, R. G.

PATENTS

Following is a list of the inventors, titles and patent members of patents recently issued to members of the Laboratories.

- Aamodt, T.—*Method of Forming a Plug of High Melting Point Plastic Bonded to a Low Melting Point Plastic*—2,989,784.
- Abbott, G. F., Jr., and Sumner, E. E.—*Bistable Trigger Circuit*—2,987,628.
- Berger, U. S.—*Cross-Modulation Measuring System*—2,987,586.
- Callaway, W. B., and Deltuvia, A. A., Jr.—*Printing Apparatus*—2,989,910.
- Collier, R. J., and Feinstein, J.—*Microwave Amplifier*—2,988,669.
- Courtney-Pratt, J. S.—*High Speed Cine-Camera*—U.K. 821,538.
- Courtney-Pratt, J. S.—*Piezoresistive Compensators*—2,990,529.
- Cutler, C. C.—*Traveling Wave Tube*—2,989,661.
- Deltuvia, A. A., Jr., see Callaway, W. B.
- Doherty, W. H.—*Hybrid Sideband Frequency Modulation System*—2,989,622.
- Doucette, E. I., and Spector, C. J.—*Semiconductor Capacitor*—2,989,650.
- Dunlap, K. S.—*Crosspoint Switching Network Control System*—2,987,579.
- Feinstein, J., see Collier, R. J.
- Fogarty, L. L.—*Magnetic Core Counting Circuits*—2,989,647.
- Gianola, U. F., see Sharp, L. V.
- Grant, C. T.—*Wave Filter*—2,990,525.
- Greiner, E. S.—*Processing of Boron Compact*—2,990,261.
- Hall, A. D., and Zarouni, R.—*Tandem Echo Suppressor Circuits*—2,990,457.
- Haring, H. E.—*Electric Batteries*—2,988,587.
- Hefele, J. R., and Mattke, C. F.—*Scanning Mechanism for Radio Signaling Apparatus*—2,987,722.
- Hershey, H. J., Jordan, H. G., and Restall, W. E., Jr.—*Telephone Dial Light*—2,988,631.
- Israel, J. O.—*Apparatus for Generating Oscillations of Different Frequencies*—2,987,680.
- Jordan, H. G., see Hershey, H. J.
- Ketchledge, R. W.—*Position Control System*—2,990,505.
- Kiltz, R. M.—*Switching Apparatus*—2,988,672.
- Mallery, P.—*Magnetic Control Circuits*—2,987,625.
- Mallery, P.—*Magnetic Memory Arrangement*—2,988,733.
- Malthaner, W. A.—*Cathode Follower Tube Circuit*—2,987,677.
- Mason, W. P.—*Stabilization of Quartz Crystal Frequency Controlling Elements*—2,989,799.
- Matthias, B. T.—*Ferromagnetic Material*—2,989,480.
- Mattke, C. F., see Hefele, J. R.
- Power, F. S.—*Manufacture of Dry Electrolytic Devices*—2,989,447.
- Restall, W. E., Jr., see Hershey, H. J.
- Seidel, H., and Weiss, J. A.—*Magnetically Controlled Wave Guide Switch*—2,989,709.
- Sharp, L. V., see Gianola, U. F.
- Smith, L. M.—*Transistor Pulse Generator*—2,989,651.
- Spector, C. J., see Doucette, E. I.
- Sumner, E. E., see Abbott, G. F., Jr.
- Warner, R. M., Jr.—*Semiconductor Resistance Element*—2,989,713.
- Weiss, J. A., see Seidel, H.
- Zarouni, R., see Hall, A. D.

THE AUTHORS

Duncan H. Looney was born in Muskogee, Oklahoma. He earned the bachelor of science degree from Purdue University in 1948 and the Ph.D. from Massachusetts Institute of Technology in 1953. While working on his doctorate degree he was a research assistant in the M.I.T. Research Laboratory of Electronics.

Mr. Looney joined Bell Laboratories in 1953. During his first year with the Laboratories he was engaged in development of transistors and related semiconductor devices. Since then he has worked on development of solid-state memory and logic devices.



D. H. Looney

He was recently named to head a new sub-department in solid-state devices with emphasis on memory devices.

Mr. Looney is a member of the American Physical Society and the Institute of Radio Engineers. He is the author of "Electronic Memory Devices" in this issue.

David C. Hogg was born in Vanguard, Saskatchewan, Canada. He received the B.Sc. degree from the University of Western Ontario in 1949, and the M.Sc. degree and Ph.D. degree from McGill University in 1950 and 1953 respectively.

Mr. Hogg joined Bell Laboratories in 1953 in the Radio Re-

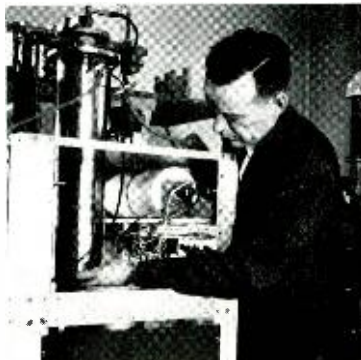

D. C. Hogg

search Department. He is a senior member of the IRE and in 1960 was elected member of the Union Radio Scientifique Internationale (Commission 2). He received a fellowship from the National Research Council of Canada in 1952.

Mr. Hogg is co-author of the article on low-noise measurements appearing in this issue.

H. E. D. Scovil, co-author of the article on low-noise measurements, was born in Victoria, B.C., Canada, and attended the University of British Columbia, from which he received the B.A. and M.A. degrees in 1948 and 1949. Subsequently, he studies at Oxford University, where he was awarded the D. Phil. degree in 1951. During 1951 and 1952, Mr.



H. E. D. Scovil

Scovil was a Nuffield Research Fellow at Oxford, and then returned to the University of British Columbia as Assistant Professor during 1952-1955.

In 1955 he joined Bell Telephone Laboratories where, as a member of the Device Development Department, he has done extensive development work of masers. Recently, Mr. Scovil was named head of the sub-department responsible for solid-state maser development.

John B. Bishop, author of "A New Surface-to-Air Data Communication System" in this issue, is a native of Auburn, N. S. He received his B.Sc. from Acadia University, Wolfville, N. S., in 1921,



J. B. Bishop

and the Ph.D. in Physics from Cornell University in 1926.

After two years in design and development at the Westinghouse Lamp Co., he joined the Laboratories in 1928, working on the development of transmitters for commercial ship-to-shore and military communication systems, until 1940. During the war years, he worked on the development of various search and fire control radar projects.

Immediately following the war, he spent two years developing FM transmitters for broadcast application. Since 1948, he has been in

AUTHORS CONTINUED

charge of a group responsible for the design and development of weapons control and data communication equipment for the armed forces.

Mr. Bishop is a member of the Institute of Radio Engineers and Sigma Xi.

W. B. Callaway, a native of Florence, Alabama, received his B.S. in E.E. from Alabama Polytechnic Institute in 1938. After a year with the Varityper Corporation, he joined the Laboratories in 1940, working in various transmission, switching, and signaling development projects. During World War II, Mr. Callaway spent three years in the U. S. Naval Reserve, developing equipment and tactics for antisubmarine warfare, as well as in operational flying in both the South Atlantic and Pacific theatres.

Most recently, he has been



W. B. Callaway



J. W. Osmun

engaged in systems engineering studies, particularly in the application of computers and data processing techniques to the measurement and analysis of telephone traffic. He is the author of "The Art of Counting Calls" in this issue.

J. W. Osmun was born and raised in Sparks, Nevada and now lives in Scotch Plains, N. J. From 1943 to 1947 he served with the U. S. Army in the South Pacific as a parachutist. Mr. Osmun received a B.S.E.E. from University of Nevada in 1953, and that year he joined the Laboratories and graduated from the CDT program in 1956. A member of the Power Development Department, he has specialized in ringing power plants and transistorized dc-dc power converters. Author of "A Statistical Ammeter" in this issue, Mr. Osmun is a mem-

ber of the AIEE, Phi Kappa Phi, and Sigma Tau.

A. F. Pomeroy was born at Buffalo, N. Y. He graduated from Brown University in 1929 with a B.S. degree in Engineering and joined Bell Laboratories that year. His early work was devoted to developing test and measurement equipment and the study of transmission lines. His work with manufacturers has resulted in the development of waveguides with improved transmission qualities. Since 1956 he has been concerned with the development of ferrite devices such as microwave attenuators, isolators and switches. Early last year, Mr. Pomeroy transferred to Western Electric at the Merrimac Valley Works. A member of the IRE, he is the author of "The Ferrite Isolator: A New Kind of Pad for TJ Radio-Relay" in this issue.



A. F. Pomeroy

What was Bell Telephone Laboratories doing ON FRIDAY, JUNE 30, 1961?

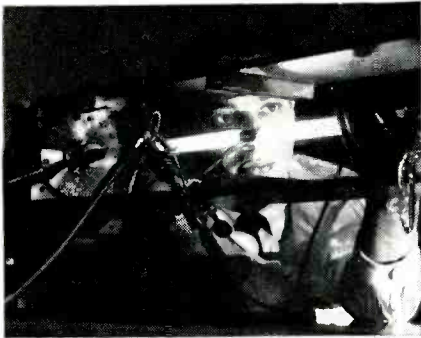

It was exploring the communications possibilities of the gaseous optical maser — a device which generates continuous coherent infrared radiation in a narrow beam.

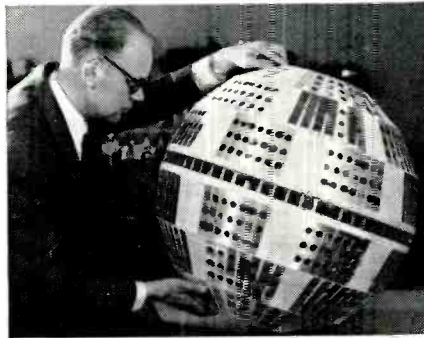

It was preparing an experiment in world-wide communications using "active" satellites powered by the solar battery, a Bell Laboratories invention.



It was completing the development of a new "heavy route" Long Distance microwave system capable of handling over 11,000 two-way conversations at once.



It was developing an anti-missile defense system designed to detect, track, intercept and destroy an enemy ICBM — in a matter of minutes.



It was demonstrating the potentialities of the superconducting compound of niobium and tin for generating, with little power, magnetic fields of great strength.

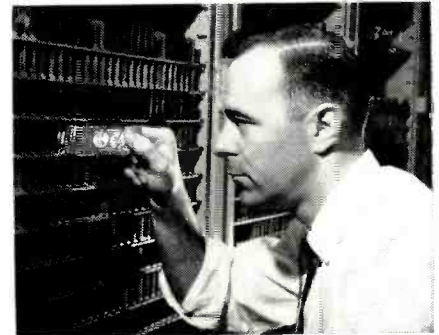

It was experimenting with an electronic central office at Morris, Ill., which is capable of providing a wide range of new telephone services.



It was perfecting the card dialer which permits, through insertion of a punched card into a slot, automatic dialing of frequently used numbers.



It was developing improved repeaters or "amplifiers" to increase greatly the capacity and economy of undersea telephone cable systems.

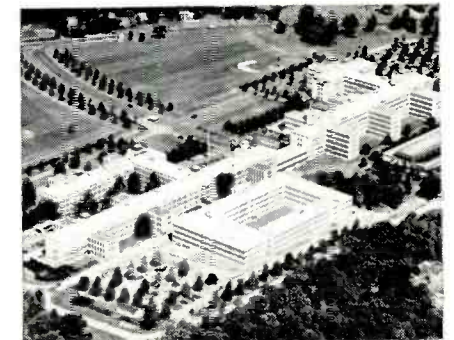

It was continuing its endless search for new knowledge under the leadership of scientists and engineers with world-wide reputations in their chosen fields.

Bell Laboratories scientists and engineers work with every art and science that can benefit communications. Their inquiries range from the ocean floor to outer space, from atomic physics to the design of new telephone sets, from the tiny transistor to massive transcontinental radio systems. The goal is constant—ever-improving Bell System communications services.

BELL TELEPHONE LABORATORIES

World center of communications research and development

