

# AM Proof of Performance Manual

*Published by*

**BROADCAST** engineering®

# AM Proof of Performance Manual

Includes the test setup and procedures  
along with the test charts and logs.



Written and compiled by  
Broadcast Engineering Magazine

1014 Wyandotte Street  
Kansas City, Mo. 64105



First Printing December, 1974

Copyright, ©, 1974, Intertec Publishing Corp, Kansas City,  
Missouri. Printed in the United States of America.

All rights reserved. Reproduction or use in any manner of  
editorial or pictorial content without express permission  
is prohibited.

---

# An Easy Guide To The AM E.P.M.

---

## Introduction

Page 5

## Chapter 1. - Preparing the test gear

A look at good engineering practice as it relates to the test equipment including the recording of serial numbers and determining the accuracy of the measuring gear.

Page 6

## Chapter 2. - Connecting the test equipment

The critically important job of connecting the test equipment so that hum, RFI, impedance mismatches, etc., don't pollute the measurements.

Page 11

## Chapter 3. - Pre-testing the station

How to make some rapid checks to ascertain whether or not the station is capable of passing the Proof before the complete formal test series is done with an eye toward clearing up technical problems before they have a chance to ruin a half complete Proof. A smart engineer can be sure before he starts that his Proof will be a success.

Page 13

## Chapter 4. - An efficient method of measurement

How to make simultaneous response and distortion measurements. What order the Performance tests are done in can make the difference between one or two nights of testing. This chapter gives the optimum step by step process.

Page 16

## Chapter 5. - Evolving the graphs

Using the data from the summary sheet to assemble a meaningful set of performance graphs that show how the station stacks up against minimum standards.

Page 19

## Chapter 6. - The data summary sheet

A description of the data summary onto which all of the test results are originally recorded. This section also explains the value of organization and details how the test results should be entered, i.e., decimal places, units, etc.

Page 22

## Chapter 7. - How to check for RF harmonic output

Using a communications receiver or field strength meter or meters to test for transmitter harmonic output suppression.

Page 23

**Chapter 8.—Your individual forms for completing the equipment performance tests are located in the back of this manual.** They can be cut out or left in the manual. Extra sets of forms are available from Broadcast Engineering for \$1.00. A check or money order should accompany your order.

Page 25

---

## Introduction

---

The Equipment Performance Measurements is quite possibly the most important engineering assignment that most radio station chief engineers have. The Proof is important for two reasons: first of all, it demonstrates to the FCC that the station is at least able to meet minimum technical standards or, as is often the case, far exceed them. A satisfactory Proof also assures the broadcaster that his facility is doing what it is supposed to do, at least technically.

Conducting the Performance Measurements is a real responsibility. It must be signed by the engineer or engineers making the measurements, and the results are among the factors that determine whether the broadcaster deserves to keep the station license.

This manual was designed to fill the need for a detailed guide to equipment performance measurements based on approved interpretations of the FCC rules that set forth the requirements. Every effort has been made to answer the questions that often arise and to present an efficient test format, complete with easy to use forms and graphs. In addition to aiding the engineer in the preparation of the Measurements, the in-depth analysis of each procedure and regulation provides the reader with a genuine understanding of what the FCC expects, how the requirements can best be met, and why.

Ideally, every station would meet every standard without a hitch, but in the real nuts and bolts world, this is not always the case. It is sometimes much more time consuming to get a facility to the point where it can pass the requirements than to actually perform the measurements.

For this reason, the manual also covers some of the most common areas of technical difficulty and suggests methods of isolating the problems and correcting them so that the Proof may be successfully completed.

While the use of this guide certainly has the effect of reducing the amount of time required to make the Equipment Performance Measurements, its primary intent is to assist the engineer to make a more thorough, accurate and meaningful E.P.M.

# CHAPTER 1.

## Preparing The Test Equipment

It is very important that the test equipment be very thoroughly checked out before the Measurements are begun. The test gear does not have to be new to be good, or expensive to be suitable. While every engineer likes to work with the best possible equipment, some of the simpler, less expensive audio generators and distortion meters are capable of testing down to 0.1% total harmonic distortion.

Whatever test equipment is used, the important thing is that its operating condition is known. The frequency response and distortion tests required by the FCC are all relative measurements, which makes the job of the test equipment a bit easier. The accuracy of these tests does not depend on the quantitative accuracy of the units measured, but rather on the relationship of the quantities to each other. For example, the response variations in decibels is an expression of the ratio between two voltages, so that the exact voltage measured is not

important. Harmonic distortion is expressed as a percentage of the signal voltage; once again, a relative value. In either case, if the voltmeter employed calls 1 volt 1.1 volts the accuracy of our relative measurements will not be impaired as long as 0.5 volts reads out as .55 volts on our meter.

While good engineering practice dictates that we should endeavor to keep all test instruments as accurately calibrated as possible, we need not begin our job at The National Bureau Of Standards.

Let's take a look at what test gear is required and discuss the methods of checking its operation and connection to the system under test.

### Minimum Test Equipment Required

- A. Audio Frequency Sine-wave Generator/Output Attenuator\*
- B. Harmonic Distortion Meter/Audio Voltmeter\*
- C. Communications or General Coverage Receiver

### Useful Additions

- A. Cathode Ray Oscilloscope
- B. Precision Attenuator ("Gain Set")
- C. Field Intensity Meter(s) with 16 MHz coverage capability

\*Most of the commonly available units include both functions in a single instrument.

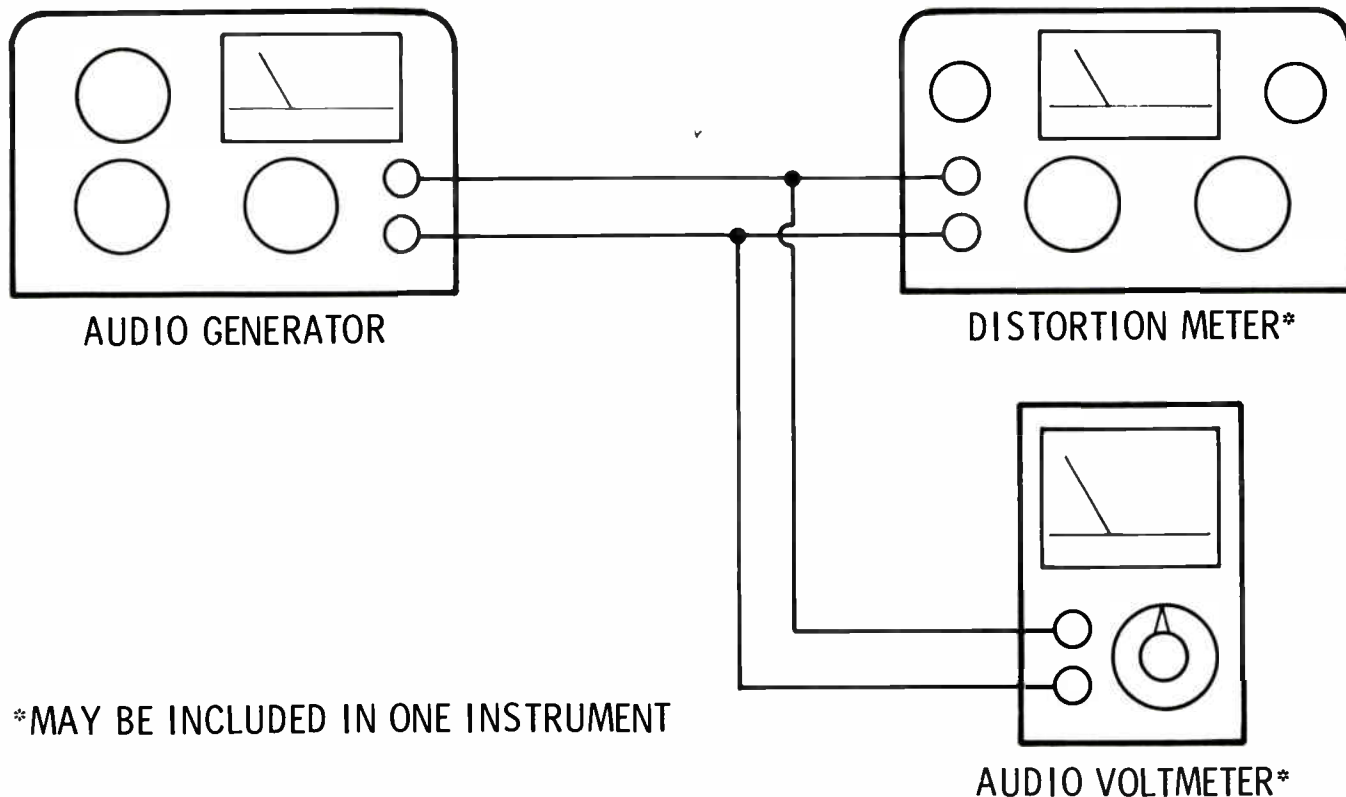

\*MAY BE INCLUDED IN ONE INSTRUMENT

Figure 1. Checking the test equipment performance.

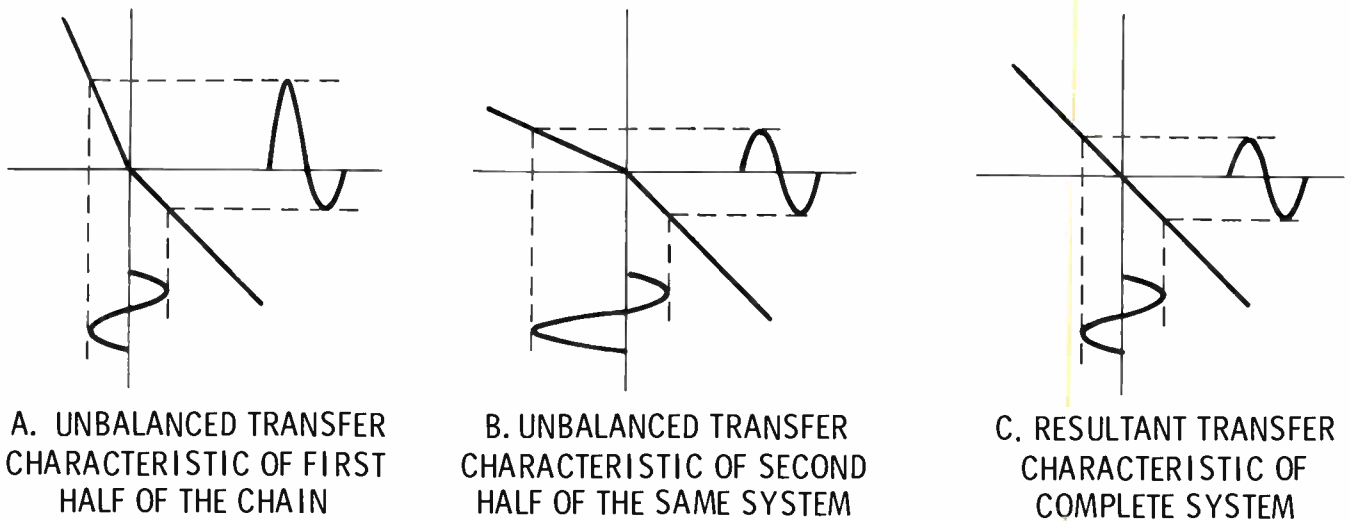

**Figure 2. The Effect Of Complimentary Transfer Characteristics.** It is not uncommon for the total system distortion to be less than the total of the distortion of each of the parts of the same system. In the case illustrated above, the nonlinearity is exaggerated for clarity and the resulting distortion is actually less than either half of the system alone! The input signal when applied to transfer A becomes distorted as a result of the base line shift caused by the imbalance. When the output of the first half of the system is applied to transfer B, the

amplitude of the positive and negative halves of the waveform is returned to balance and a relatively undistorted output is obtained. If the phase of the input to transfer B had been reversed, the distortion would have been increased rather than decreased however, which is one of the reasons that the audio generator's distortion cannot be subtracted from the distortion readings. Transfer C is the resultant transfer of A to B in phase.

Before proceeding, be sure that all test leads are equipped with the proper connector for making solid, well shielded contact with the console microphone input terminals and the modulation monitor instrument output. Alligator clip connections, sections of unshielded cable and haphazard grounds often cause needless grief and lost time. There is also an understandable psychological advantage to starting out with a "tight ship".

If you must use a calibration chart with your generator, remember to subtract the generator errors from the transmitter response deviations measured before entering them on the data sheet when we begin the Proof. If the generator error is 0.2 dB or less, it may be disregarded, as that would allow a test resolution of ten times the FCC 2 dB response uniformity requirement.

#### Checking The Test Equipment For Response Variation

#### Measuring The Test Equipment Distortion Level

Feed the output of the audio generator into the audio voltmeter input. The generator's output should be held constant while the audio voltmeter indication is observed. Vary the frequency from 50 to 7500 Hz and note any deviation from the 1000 Hz value. If there is no change in the indication, then the frequency response over the band that our Proof will cover is perfect and no corrections will have to be made to the data that is measured.

A harmonic distortion meter will read hum, white noise and distortion all as distortion, so we must remember that even if our generator is producing a perfect waveform its output noise level must be less than 0.1% or -60 dB for the distortion meter to indicate less than 0.1% (assuming that the distortion meter is perfect).

If the audio voltmeter does show a deviation, record the error in dB for 50, 100, 400, 5000 and 7500 Hz.

As a practical matter, most generators and harmonic distortion meters exhibit a noise level of around -80 dB or 0.01%, so, this is usually not a problem as long as you are careful to avoid ground loops when making the connections to the equipment under test.

If the audio generator employed has a built in voltmeter, you will find that it is quite easy to keep the output perfectly uniform while the frequency is varied so that no calibration chart is required. If the generator does not have a meter, then obviously, we are relying on the accuracy of our audio voltmeter to check its output uniformity and it would be a good idea to double check by using a second meter and running the same spot checks. Only the worst audio voltmeters would deviate from flat over a 7500 Hz band, however, because most are flat to 100,000 Hz.

If you feed the audio generator directly into the harmonic distortion meter, the total hum, noise and distortion for the combination may be measured. For AM Proof measurements, if the reading is 0.5% or less, the instruments may be considered satisfactory since this is 1/10 of the lowest FCC requirement for AM broadcast. Most distortion meter-audio generator combinations yield a residual hum, noise and distortion level of about 0.1%. **CAUTION: The residual test equipment distortion may not be subtracted from the system distortion figures when doing the proof.**

Subtracting the test equipment distortion is not a valid technique because distortions don't necessarily add. As a matter of fact, the only time they would add would be when all of the harmonics were exactly in phase, a near impossibility when you consider that this would have to be true for every modulating frequency. Non-linearities can also cancel each other if their transfer characteristics are complementary. (See Figure 2.) This accounts for the fact that a studio with 1% distortion can be connected to a line amplifier with 1% distortion and the line amp connected to a transmitter with 3% distortion. One might expect the system distortion to be 5%, but typically it would test at about 3.5 to 4% because of the factors we've just discussed.

In the FCC rules for FM technical standards 73.317 (a)(3)(ii), the Commission wisely recommends that no portion of the system exceed 1/2 the distortion limit, since at some modulating frequency the distortions could add. The same advice applies to our AM systems of course. So, to summarize, the fact that distortions usually don't add makes our broadcast systems better than the sum of their parts, but this also means that the test gear distortion cannot be subtracted.

The FCC requires that the distortion measurements be made with a test bandwidth of 16,000 Hz (above the second harmonic of 7.5 kHz and at the limit of audibility), a requirement that is easily met as most harmonic distortion meters will pass at least 40 kHz.

Noise tests must be made with a 30 to 20,000 Hz bandwidth, also easy to meet since most audio voltmeters are flat to 100,000 Hz.

A word of caution here: **if your voltmeter has a built-in 1 kHz high pass filter, it must be switched out. The required bandpass starts at 30 Hz. The high pass filter is great for getting hum out of the measurements, but not out of the transmitter!** These filters are installed in the test gear as a diagnostic aid to enable the user to determine how much of a noise or distortion reading is hum and how much is white noise or distortion.

To check the residual noise level of the audio voltmeter, short its input and switch it to the most sensitive range. It should have a noise level 70 dB or so below the modulation monitor output level corresponding to 100% modulation. Obviously, the noise in the test equipment may not be subtracted from the system noise measured. Since the FCC residual noise limit is only -45 dB, we should not expect to have much of a problem passing the noise test unless there is a definite defect in the equipment or Telco loops.

If all of the test equipment is in good operating order, enter the serial number and manufacturer's model number of each unit in the test equipment and

procedures section of the Proof. The serial numbers are recorded so that the tests may be exactly duplicated at any time in the future. Proper documentation of any test or experiment in any of the sciences calls for the recording of the serial numbers of the equipment used and a detailed description of the methods employed.

Figure 3 is an outline of a suitable test equipment and procedures section, which you may use as a guide for writing this portion of your Proof. As you can see from the outline, there are three main parts to the test equipment and procedures description: a description of the test equipment employed, a description of the test procedures, and a diagram showing how the test equipment was connected to the system and the normal audio path through the system. It is not practical to use a form for this part of the Proof because of the great variation in the way broadcast audio chains are assembled.

More than one engineer may work on the Proof, but one engineer must assume the overall responsibility of the supervisor, and the description of the procedure should indicate who was in charge. Only the engineer in charge need sign each page, but it is a good idea to list anyone who assisted.

At this point a very interesting and much debated question arises: Who is qualified to assist with the Proof anyway?

Paragraph 73.93 of the rules requires that equipment performance measurements be done by a First Class Operator only. While many engineers feel that a lesser grade operator may be employed to operate the audio generator with the First Class man at the transmitter making the measurements, this is not a valid procedure because the operation of the generator is as important to determining the results of the measurements as the operation of the audio voltmeter. The accuracy of the response data is almost totally dependent upon the careful control of the input signal.

Section 73.93(b) requires that the performance measurements be performed only by a First Class Operator or by or under the direction of a broadcast consultant regularly engaged in the practice of broadcast station engineering during a period of operation when a First Class Operator is in charge of the transmitter. The First Class Operator must be in control of the transmitter either directly or by remote control and must be responsible for the data developed during the performance measurements. If a Third Class Operator is employed to feed audio from the studio, remember that the operation of the generator is as important to determining the results of the measurements as the operation of the audio volt meter.

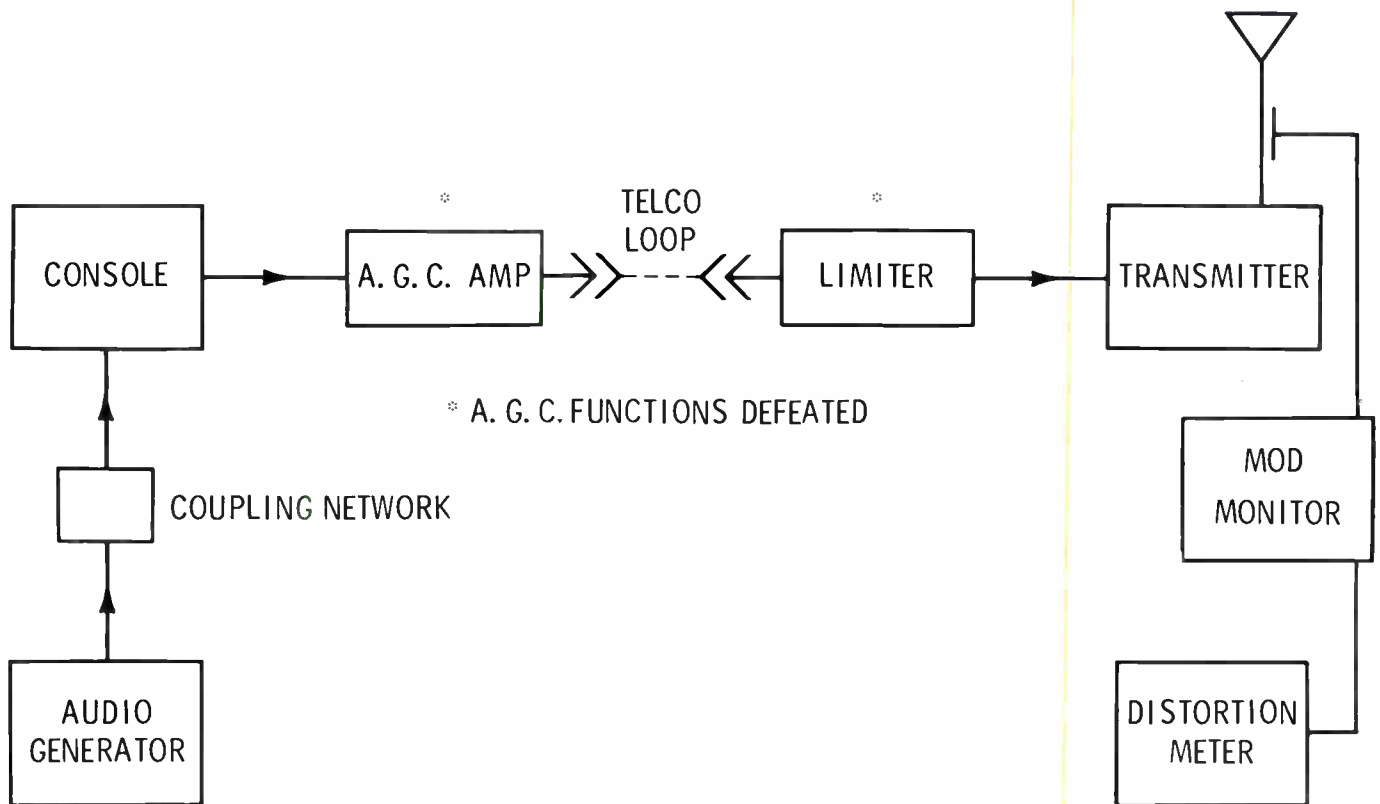

**Figure 3a.** Sample test equipment connection diagram.

**Figure 3 - Test Equipment  
And Procedures Outline**

- I. Equipment List (Give manufacturer, model No. and Serial No. of each unit)
- II. Description of the methods employed and facts relating to the conduct of the tests
  - A. Station call letters
  - B. Personnel
    1. Who in charge
    2. Assistants
  - C. Reference to the equipment list
  - D. Reference to the equipment connection diagram
  - E. Test resolution
    1. Frequency response accuracy of test equipment
    2. Residual hum, noise and distortion of test equipment
  - F. Statement that all station equipment was adjusted for normal operation
  - G. Description of how the AGC was defeated
  - H. How the actual measurements were made
    1. How the response was measured
    2. Method of checking distortion
    3. How the carrier shift was measured
    4. How the noise test was made
    5. Description of the method employed to determine adequate transmitter harmonic suppression
  - I. Statement that all of the data is true and accurate to the best knowledge of the supervising engineer
- III. Equipment Connection Diagram
  - A. Show the path of the audio from the microphone input terminals to the transmitter antenna output circuit
  - B. Show the actual points of test equipment connection



---

### Sample Measurement Statement

The following equipment performance measurements for WXYZ-AM were conducted on January 25, 1975. All of the measurements were made by, or directly under the supervision of Henry Ampere, chief engineer, WXYZ-AM. Paul Phon, WXYZ maintenance supervisor, assisted with the tests. The test equipment specified in the equipment list was employed for all of the measurements and was connected as shown in the equipment connection diagram.

Prior to its use, the test equipment frequency response was checked and found to be within 0.1 dB from 30 to 16,000 Hz. The residual hum, noise and distortion of the audio generator and harmonic distortion meter combined was 0.1%.

All station equipment was adjusted for normal operation and all equipment normally used in the system between the microphone input and transmitter antenna output was included in the tests. The AGC functions of the leveling amplifier at the studio and the peak limiter at the transmitter were defeated by switching their function selectors to the "test" position provided by the manufacturer for this purpose.

The frequency response of the system was measured by adjusting the audio generator to produce the modulation level indicated with a modulating frequency of 1000 Hz, then varying the frequency while recording the generator output required to produce the same modulation level at the frequencies indicated.

The harmonic distortion was measured by adjusting the audio generator to produce the modulation levels indicated with the modulating frequencies indicated and measuring the distortion at the modulation monitor instrument output terminals. The carrier shift at 400 Hz

was measured at each modulation level using the carrier level meter incorporated in the modulation monitor.

The input signal was removed and the system noise was measured at the modulation monitor instrument output. The noise level given is relative to the voltage at the same point at 100% modulation.

The receiver listed in the equipment section was tuned to the harmonics of the transmitter operating frequency at a distance of 0.79 miles from the antenna to avoid internally generated spurious responses due to receiver overload.

All of the data contained herein is true and accurate to the best of my knowledge.

Engineer \_\_\_\_\_

Lic. No. \_\_\_\_\_

Date \_\_\_\_\_

It is recommended that the description of equipment and procedures used in making performance measurements be of sufficient detail that the setup and measurements could be duplicated by another engineer following the given information. The procedures should include settings of gain controls, etc.

Description of measurements or checks of harmonic and spurious emissions should include the actual location of the observations including the antenna used. It is recommended that checks be made with each antenna radiation pattern and at more than one location when a directional antenna system is used.

# CHAPTER 2. Connecting The Test Equipment

Let's start by taking a look at the console's schematic diagram so that we are sure that our connection to the microphone input terminals will be a proper impedance match.

One of the most mis-used terms in communications is the terms "balanced" as it refers to transmission lines and input/output circuitry. Figure 4a shows a truly balanced, transformer-coupled circuit. Note that each transformer is center-tapped to ground. This circuit will exhibit a degree of common mode rejection which depends upon the accuracy of the transformer center-tapping or "balancing". The effect is identical to that obtained with balanced push-pull amplifier circuitry.

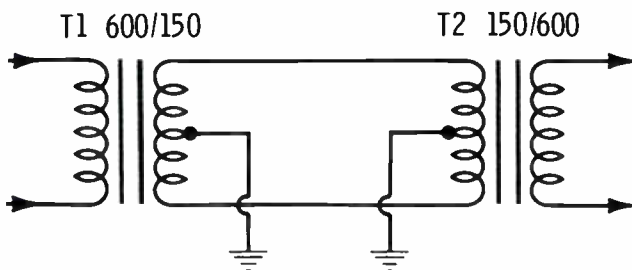
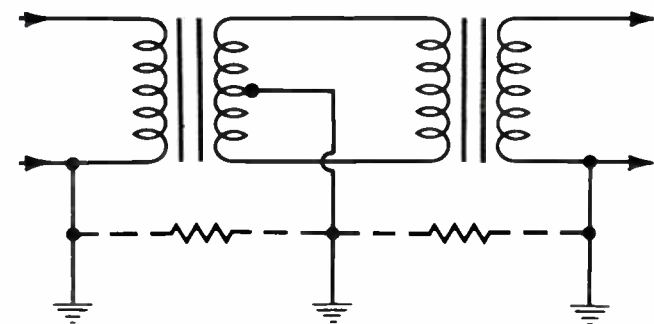

Figure 4a.



MULTIPLE GROUND CONNECTIONS OPEN THE DOOR FOR "GROUND LOOPS" THAT COULD RENDER THE MEASUREMENTS INVALID.

Figure 4c.

Any hum or noise would have to enter the top and bottom halves of the circuit 180 degrees out of phase to be passed to the output. Any interference affecting the top and bottom halves in common, as a hum field would, causes its own cancellation or rejection, hence the term "common mode rejection".

This type of truly balanced circuitry makes long distance wire transmission with surprising noise immunity possible, but is seldom found in studio equipment as the distance of transmission over the connecting lines is usually a matter of feet rather than miles. It is very important to know how your console input is wired, but unfortunately, the manufacturers usually call any transformer-coupled circuit "balanced".

Figure 4b shows what would happen if the audio generator's unbalanced, half grounded output were to be

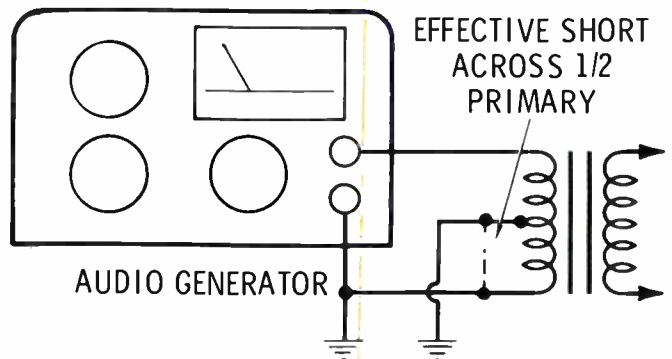

DIRECT CONNECTION ACROSS A TRULY BALANCED INPUT CAN RESULT SEVERE MISMATCHING AND TEST CONDITONS NOT SIMULATING NORMAL OPERATION OF THE INPUT CIRCUIT.

Figure 4b.

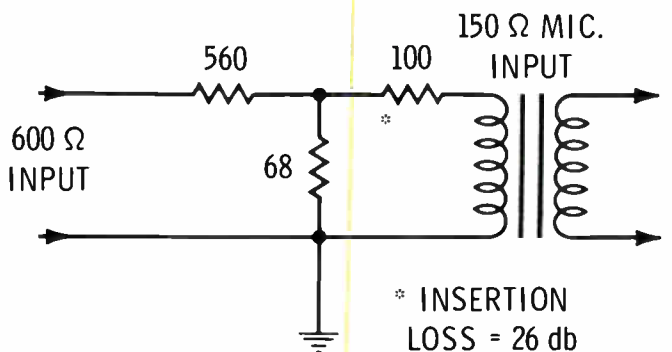

A SIMPLE METHOD OF RESISTIVE COUPLING TO THE MIC. INPUT.

Figure 4d.

connected to a balanced input. As you can see, the impedance mis-match would be 2 to 1. On the other hand, Figure 4c shows what happens when a transformer with a balanced secondary is used to couple to a floating but unbalanced input configuration.

Adding a transformer to the audio generator's output is not a cure-all. There is no substitute for knowing the characteristics of the input circuit and making an intelligent decision on the proper coupling technique.

If a matching transformer is required to connect to your console, be sure that it is included in your test equipment response checks so that any effect that it might have is recorded. Load the secondary of the transformer with a resistor equal to the input channel impedance, if it is an unbalanced secondary. If the secondary is balanced, leave the secondary center tap disconnected for coupling to the unbalanced voltmeter input so the transformer may be checked.

You will find that the larger transformers usually are operated so far below their saturation levels, when used to feed a microphone input, that their low frequency response usually extends almost to DC. At 50 to 600 ohms impedance, winding capacitance usually isn't a problem, so the high end of most of the coupling transformers is usually flat to well above the audio range, if a quality unit is chosen. Transformer distortion is also generally negligible at microphone levels, but great care must be taken to avoid hum pickup or RFI.

Don't be too hasty to tack a transformer onto the output of the audio generator, because very often it is not necessary, and the purist situation, technically,

would be to couple directly to the input circuit and thus eliminate an intervening link that might have some effect, though small, on the measurements.

As long as the console input does not have a grounded center-tapped transformer and the audio generator is located just a couple of feet away, grounding the lower half of the floating input will not cause any additional noise. Figure 4d illustrates this coupling technique.

Note that a resistive matching pad is used so that the generator sees 600 ohms while the console input is loaded with 150. If your console input is balanced and you have to add a matching transformer, it is a good idea to use the isolation pad shown in Figure 4d.

Although your audio generator may be designed to drive a 600 ohm load, its internal output impedance may be quite a bit lower, which would be a mis-match to the transformer primary. The switch-selected internal load in some generators is in parallel with the output to assure that the generator is properly loaded when driving a high impedance circuit and will not increase the internal impedance but actually lower it. A quick look at the schematic of your audio generator will tell you if it already contains an isolation pad.

The connection to the modulation monitor is more straightforward, since the instrument output of these units is usually designed to feed the harmonic distortion meter's high impedance input. Be sure to keep the connecting cable from the monitor to the distortion meter as short as possible to avoid noise and RF pickup.

After connecting the distortion meter, turn the trans-

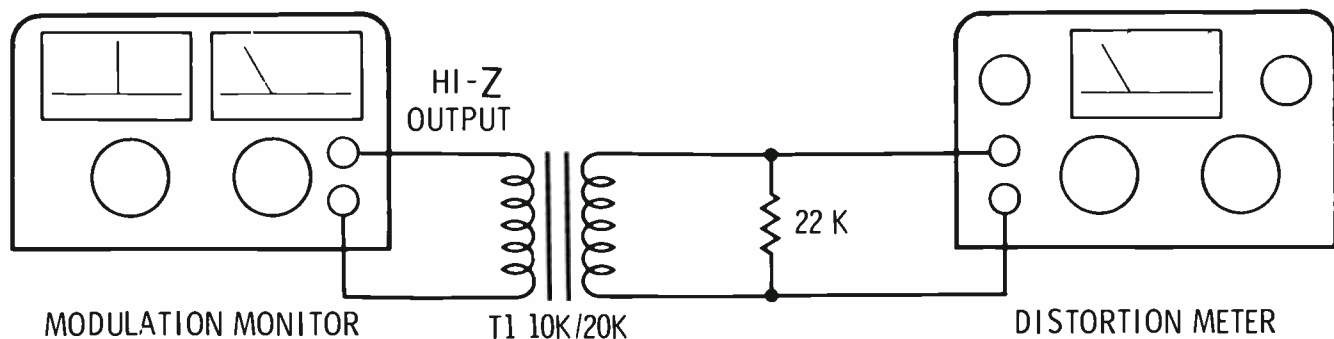

mitter carrier off and switch the meter to its most sensitive scale to see what the residual level is. If the AC plug does not have a ground pin, try reversing it to see if a lower hum level can be obtained. You should be able to get a residual level of about -60 dB or more with no RF input to the monitor.

If a good signal to noise ratio cannot be obtained with the transmitter off, there is not much hope of obtaining one with the carrier on! The most common cause is a ground loop or at very high power installations, RFI.

The high impedance isolation circuit shown in Figure 5 usually takes care of either problem. Isolating the modulation monitor ground from the distortion meter ground eliminates the ground loop and the limited frequency response of the transformer (few will pass 540,000 Hz) blocks the RF.

The frequency response of the transformer must meet the 16,000 Hz FCC requirement, however. Small variations in the response (1 or 2 dB) are not important, because the actual response data is taken from the modulation meter and the audio generator settings. The transformer distortion *is* important because these measurements must be made through it. The better quality matching transformers will pass the instrument output voltage with less than 0.1% distortion, in most cases, so it should not be difficult to find a suitable unit.

This completes the test equipment preparation. Now that we are assured that the response and distortion data we will measure actually belongs to the radio station and not the test gear, let's see how good our facility really is.

---

**Figure 5.** A simple high impedance isolation circuit. Note that the secondary winding of the transformer is loaded with a resistor equal to the secondary impedance. The modulation monitor output impedance will usually be low enough to load the primary, but the 100,000 ohm input Z that is typical of most distortion meters is too high and unless shunted down can cause a high frequency roll-off. Using a transformer with a very high impedance secondary may invite RF pickup problems.

---

---

## CHAPTER 3. Pre-Testing The Station

---

For the engineer to be able to go through the equipment performance measurements efficiently with a minimum of wasted time, the facility must, of course, be up to par. You must remember that if you have completed part of the measurements and then find that an adjustment to the transmitter is required, the tests that have been completed are usually invalid.

As a practical example, if we begin by making a complete frequency response and distortion series only to find that a defect in the Telco loop from the studio has rendered our noise level unusable, we must re-run the same series of tests after the audio line problem has been serviced. Repeating the noise test alone will not suffice, because whatever repair or adjustment was made to correct the noise could possibly alter the frequency response or distortion performance.

Obviously, it doesn't take many of these unexpected little setbacks to turn a seemingly simple Proof into an all-week affair. The best way to be sure that this won't happen is to pre-test the station. There are many ways to quick-check a facility, but probably the best method is to determine which portions of the measurements will be the most difficult to pass and then prepare a pre-test procedure to be sure that the toughest requirements can be met. The following procedure will serve well for most AM facilities.

### LIMITS

- 7.5% A. Check distortion at 100% modulation with modulating frequencies of 50 Hz and 7.5 kHz. Most Am rigs exhibit an increase in distortion at the frequency extremes, particularly the low end, and the conditions usually worsen as the modulation is increased.
- 2 dB B. Check the frequency response at 100 Hz and 5000 Hz relative to the 1000 Hz response, all at full modulation. Once again, high modulation levels are the most demanding at the frequency extremes.
- 5% C. Check the carrier shift at 400 Hz, 100% modulation.
- 45 dB D. Check the noise level below 100% modulation.

If the station can pass this basic series of tests, then the chances are very good that it will breeze through the

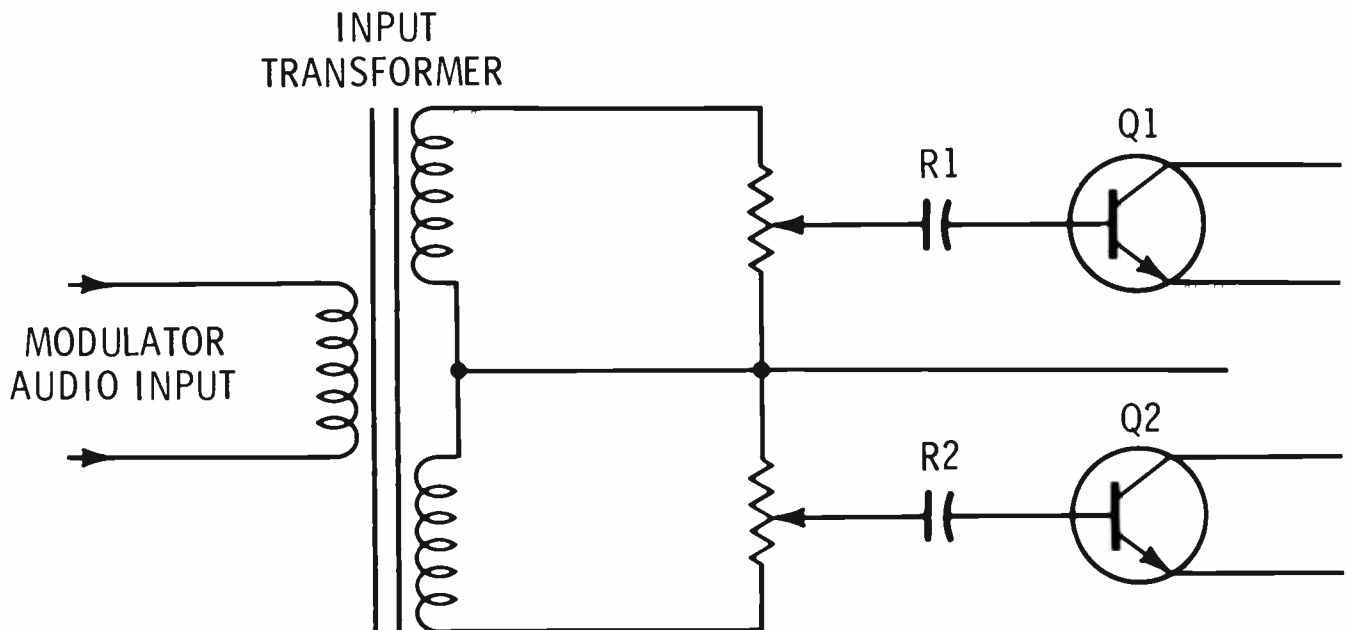

**Figure 6. Typical A.C. Balance Circuitry At The Modulator Input.** In this circuit, R1 and R2 control the a.c. balance by controlling the input voltage to each half of the audio input. In many transmitters the feedback voltage is adjusted to

obtain the same effect and others vary the bias voltage. The transmitter manufacturer's maintenance instructions usually identify these functions in the adjustment instructions, but it is up to you to know when adjustment is required.

complete Proof, since these requirements really describe the all-out performance demands placed on the system. It is well worth the few minutes that it takes to go through this electronic assurance routine. Now the big question arises: what if the station doesn't pass?

### Curing The Ills

**Frequency response defects** - These are among the easiest problems to correct because the errors are usually additive and therefore, "subtractive". In other words, if the system response is down a total of 4 dB at 5000 Hz, 1 dB of the loss could be in the console with another two in the line matching transformer and the remaining 1 dB loss in the transmitter. What makes this kind of deficiency rather easy to correct is the fact that it can be so easily isolated. As a matter of fact, the 2.5 VAC range of most VOM's is flat to above 10 kHz, and these instruments can be quite convenient for response trouble-shooting as long as the levels are high enough, and audio program levels generally are.

Start "shooting" at the console output and continue through the chain remembering that a dB here and there is going to add up in the end. Most response problems in the audio equipment can be traced to matching problems. Perhaps something has been added to the chain since the last Performance Measurements were made. RF bypass circuits which have too low a cut-off frequency and which slice into the audio range are common offenders. Also bear in mind that what seems to be a response problem can sometimes be a manifestation of a bigger distortion problem.

An extreme unbalance in an audio stage will often result in poor low frequency response in addition to

gross distortion. In any case, once the sections of the system with the most pronounced response droops are isolated, corrective action can be taken, starting with the worst offender. The reverse effect (a response rise or peak) can also occur, but because the AM response requirement only covers about 6 octaves, it's pretty hard to get into trouble here unless some over-equalization of a response loss is at fault.

**Distortion.** Non-linearity problems are more difficult to trace and usually require more time to solve because it is usually necessary to disconnect parts of the system so that the individual outputs can be sampled. While it is quite easy to bridge an audio circuit with a VOM to check the response along the way, accurate distortion measurements require that there be no hum loops or matching no-no's inflicted by our diagnostic taps. It is also important that the test results be accurately interpreted so that they may yield information leading to the defective component or adjustment.

The older tube type equipment usually can benefit from a tube change, while some of the newer solid state audio gear is rather critical to bias balance settings, particularly with respect to low frequency distortion. Be sure to follow the manufacturer's adjustment procedures when adjusting the transmitter. Obviously, there is a decided advantage to working with new finals and modulators (tubes) at Proof time, but it is, of course, illegal to remove them and go back to the old ones after the Proof is done.

It is important that the quiescent current through both halves of push-pull modulators be close to equal and that the gain of each half of the circuit be the same. You may find that the idling current of each half can be

balanced and yet the distortion is still excessive. If a scope shows no visible clipping or flattening of the waveform, then unequal amplitude of the positive and negative halves of the waveform is probably the cause. This is called base-line shift, and in transmitters it can often be traced to feedback network drift.

Some transmitters employ separate feedback loops for each side of the push-pull circuitry and since the value of these networks affects the closed loop gain of their respective halves, unless these networks are identical, AC balance cannot be maintained.

Gain controls are also found in each half of some

push-pull modulators which affect the AC balance in much the same way. Remember, too, that even if the modulator is perfect, unless the final RF power amplifier is capable of delivering that power to the load, the shape of the modulation envelope will suffer.

*Carrier shift.* The best place to start working on a carrier shift problem is at the AC power input to the transmitter. Connect an AC voltmeter to the lines at the transmitter. If the line voltage drops 5% when the 400 Hz modulation is brought up to 100%, one can hardly expect the transmitter to maintain the carrier at 95% or

OSCILLATION  
OVER WHITE NOISE

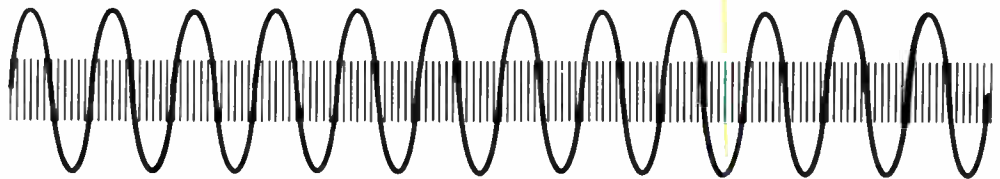

IF THE NOISE IS A HIGH FREQ OSCILLATION, THE SCOPE SWEEP CAN BE ADJUSTED TO LOCK IN ON THE SIGNAL. WHITE NOISE IS RANDOM IN NATURE AND CANNOT BE "SYNCED".

HUM (INDUCED)  
OVER WHITE NOISE

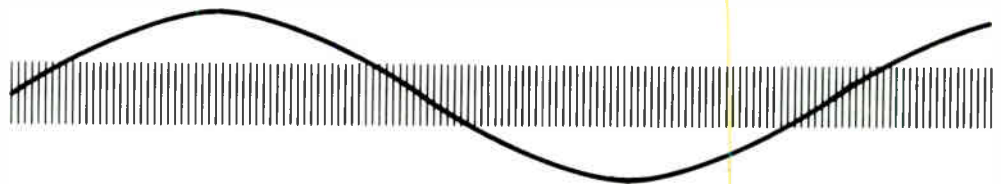

HUM PICKUP IS EASY TO IDENTIFY BECAUSE THE PATTERN WILL LOCK WHEN THE SCOPE SWEEP IS SYNCHRONIZED TO THE LINE VOLTAGE.

RIPPLE FROM  
POWER SUPPLY  
OVER WHITE NOISE

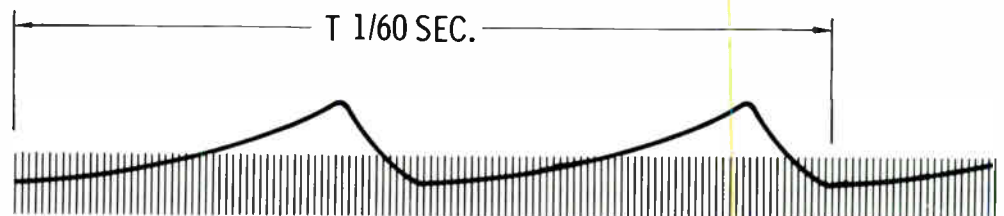

THIS TYPE OF NOISE WILL ALSO SYNC. TO THE LINE BUT IT'S FREQUENCY WILL BE A MULTIPLE OF THE POWER LINE FREQUENCY.

**Figure 7. Identifying The Noise Source By It's Picture.** Knowing the type of noise that we are dealing with can sometimes be a great aid in

finding it's source. If the scope shows an oscillation, for example, transformer hum pickup is not likely to be the source.

71  
CY  
55

better unless the plate supply is actively regulated. (Seen many of those in transmitters?)

If a good stiff supply cannot be obtained from the local power company, then line regulators will have to be installed at the station. If the line regulation is O.K., the plate supply regulation may not be up to par. Transmitter tuning and bias adjustments can also affect the carrier shift, so be sure to follow the transmitter manufacturer's instructions.

*Noise.* Before attempting to remedy a signal-to-noise deficiency, it is often helpful to first determine the nature of the noise so that a clue to its source may be obtained. An oscilloscope is a most useful tool for the task.

Figure 7 illustrates some of the waveforms that are likely to be encountered. A clipped sawtooth configuration usually indicates a power supply filtering problem, while a 60 Hz sinewave can be a sign of hum pollution somewhere along the audio chain. Bear in mind that the common mode rejection of push-pull circuitry depends upon the accuracy of the balance, so be sure that all bias balance adjustments are properly set. Remember also that many line amplifiers and most AGC amps and limiters employ push-pull amplifiers, so don't stop at the transmitter when tweeking the system for optimum performance.

It is usually best to track down the noise by disconnecting the transmitter audio input to determine if the transmitter itself is the noise source, then proceeding with the remainder of the system if the residual noise level of the transmitter alone is satisfactory. The noise isn't always in the circuitry under test either. The FCC requires that the system be adjusted for normal operation, so any inputs to the console that are open during normal operation, such as the input fed by the tape cartridge system, should be left in that position while doing the Proof. If however, the residual noise level of the cart system is in excess of -45 dB, it will be passed along to the transmitter. Turning down the fader may reduce the noise level, but if that is not your normal method of operation, it is not honest to do so. *The Commission intended the equipment performance measurements to indicate the facility's operating condition and not to be an exercise in electronic broken field running.*

Even the best and most thoroughly maintained stations can develop deficiencies between E.P.M.'s, so the fact that the pre-test has shown some problems to exist should not be discouraging; it happens to everyone at some time or other. The important thing is that the bugs are worked out in advance of the actual Proof and that the results of the Proof are the very best that the engineer in charge can do with his facility.

The pre-test is especially important when the Proof is the very first one on a new installation. At that stage of the game anything can be expected, particularly since the engineer does not have the precedent of any other Proof to fall back on.

---

## CHAPTER 4. An Efficient Method Of Measurement And A Look At The Performance Requirements

---

The equipment performance measurements should not be conducted as a race against the clock, and the engineer in charge should start out with a commitment to make the best possible Proof no matter how long it may take. If however, an efficient method of operation can avoid wasting time on redundant test operations, then the engineer is that much ahead of the game. Eliminating redundancy of operations is very simple and involves simply looking at everything that must be done from end to end to see if there are any duplicated functions and then checking to see if any two tests can share a single test function. Let's begin our analysis of the Proof requirements by listing all of the tests to be done with an eye toward spotting duplication of generator frequencies and modulation levels.

|                           |   |
|---------------------------|---|
| <b>Frequency Response</b> | @ 25, 50, 85 and 100% modulation with modulating frequencies of 50, 100, 400, 1000, 5000 and 7500 Hz.   |
| <b>Distortion</b>         | - @ 25, 50, 85 and 100% modulation with modulating frequencies of 50, 100, 400, 1000, 5000 and 7500 Hz. |
| <b>Carrier Shift</b>      | - @ 25, 50, 85 and 100% modulation with 400 Hz modulation.  |
| <b>Noise Level</b>        | - Below 100%, 400 Hz modulation.  |

Now let's rearrange the tests in a different way. This time we'll look at what tests are made at each modulation level and frequency rather than at what frequencies and modulation levels each test is made. It may sound like double-talk at this point, but the revised list of tests below should clarify things.

---

**At 100% Modulation**

|                |               |               |              |                |                |
|----------------|---------------|---------------|--------------|----------------|----------------|
| <i>1000 Hz</i> | <i>400 Hz</i> | <i>100 Hz</i> | <i>50 Hz</i> | <i>5000 Hz</i> | <i>7500 Hz</i> |
| Response       | Response      | Response      | Response     | Response       | Response       |
| Distortion     | Distortion    | Distortion    | Distortion   | Distortion     | Distortion     |
|                | Carrier Shift |               |              |                |                |
|                | Noise         |               |              |                |                |

---

**At 85% Modulation**

|                |               |               |              |                |                |
|----------------|---------------|---------------|--------------|----------------|----------------|
| <i>1000 Hz</i> | <i>400 Hz</i> | <i>100 Hz</i> | <i>50 Hz</i> | <i>5000 Hz</i> | <i>7500 Hz</i> |
| Response       | Response      | Response      | Response     | Response       | Response       |
| Distortion     | Distortion    | Distortion    | Distortion   | Distortion     | Distortion     |
|                | Carrier Shift |               |              |                |                |

---

**At 50% Modulation**

|                |               |               |              |                |                |
|----------------|---------------|---------------|--------------|----------------|----------------|
| <i>1000 Hz</i> | <i>400 Hz</i> | <i>100 Hz</i> | <i>50 Hz</i> | <i>5000 Hz</i> | <i>7500 Hz</i> |
| Response       | Response      | Response      | Response     | Response       | Response       |
| Distortion     | Distortion    | Distortion    | Distortion   | Distortion     | Distortion     |
|                | Carrier Shift |               |              |                |                |

---

**At 25% Modulation**

|                |               |               |              |                |                |
|----------------|---------------|---------------|--------------|----------------|----------------|
| <i>1000 Hz</i> | <i>400 Hz</i> | <i>100 Hz</i> | <i>50 Hz</i> | <i>5000 Hz</i> | <i>7500 Hz</i> |
| Response       | Response      | Response      | Response     | Response       | Response       |
| Distortion     | Distortion    | Distortion    | Distortion   | Distortion     | Distortion     |
|                | Carrier Shift |               |              |                |                |

---

Talk about redundancy of operation! Doing the response tests and distortion tests at each modulating frequency while the percentage of modulation is kept constant enables the engineer to kill two birds with one audio tone. This approach minimizes the amount of distortion meter input level adjustments required, because the voltage will be constant since the modulation is constant.

The data summary sheet is arranged so that if the tests are made in the order they appear on the sheet, maximum advantage will be taken of the duplication of operations that exists. Fill in the generator output settings as each modulation level is reached, but leave the calculation of the actual deviations until the Proof is complete. The distortion, carrier shift, noise etc., may be entered as it is measured. Remember that the response will be relative to the 1000 Hz sensitivity while the noise and carrier shift tests are to be performed at 400 Hz.

**Looking At The Requirements**

It is important to remember that the frequency response tests for the Proof are really modulation sensitivity vs. frequency tests. The FCC rules specify the modulation levels and we measure the relative difference in input voltage to obtain those levels for each modulating frequency.

Part 73.47 requires that the response measurements cover a range of 50 to 7500 Hz and 73.40 states that the response must be uniform within 2 dB from 100 to 5000 Hz. This may seem to be a rather loose standard, but it represents a pretty good balance between the practical limits of power bandwidth likely to be attainable from high power AM transmitters and the bandwidth of emission limitations.

Paragraph 73.40(a)(12), (a)(13) and (a)(14) describe the



**BROADCAST ENGINEERING**  
**OFFICIAL PROOF FORM**

DATA SUMMARY SHEET:  
STATION WXYZ

|                        | MOD. FREQ. (Hz) | GEN. OUTPUT (dB) | RESP. DEV. (dB) | DISTORTION(%) | CARRIER SHIFT | NOISE |
|------------------------|-----------------|------------------|-----------------|---------------|---------------|-------|
| MAX. MODULATION = 100% | 50              | -18.0            | -2.0            | 5.2           | 3.0%          | -52dB |
|                        | 100             | -19.0            | -1.0            | 4.8           |               |       |
|                        | 400             | -20.0            | 0               | 3.5           |               |       |
|                        | 1000            | -20.0            | 0               | 3.4           |               |       |
|                        | 5000            | -19.0            | -1.0            | 3.6           |               |       |
|                        | 7500            | -18.0            | -2.0            | 3.8           |               |       |
| 85% MODULATION         | 50              | -20.5            | -0.9            | 3.9           | 2.6%          |       |
|                        | 100             | -21.0            | -0.4            | 3.7           |               |       |
|                        | 400             | -21.4            | 0               | 3.2           |               |       |
|                        | 1000            | -21.4            | 0               | 3.2           |               |       |
|                        | 5000            | -21.0            | -0.4            | 3.5           |               |       |
|                        | 7500            | -20.5            | -0.9            | 3.6           |               |       |
| 50% MODULATION         | 50              | -25.3            | -0.7            | 3.1           | 1.5%          |       |
|                        | 100             | -25.7            | -0.3            | 2.9           |               |       |
|                        | 400             | -26.0            | 0               | 2.7           |               |       |
|                        | 1000            | -26.0            | 0               | 2.5           |               |       |
|                        | 5000            | -25.6            | -0.4            | 2.5           |               |       |
|                        | 7500            | -25.1            | -0.9            | 2.9           |               |       |
| 25% MODULATION         | 50              | -31.8            | -0.2            | 2.7           | 0.6%          |       |
|                        | 100             | -32.0            | 0               | 2.3           |               |       |
|                        | 400             | -32.0            | 0               | 1.9           |               |       |
|                        | 1000            | -32.0            | 0               | 1.7           |               |       |
|                        | 5000            | -31.6            | -0.4            | 1.7           |               |       |
|                        | 7500            | -31.1            | -0.9            | 2.0           |               |       |

ALL TESTS PERFORMED BY Henry J. Ampere

DATE 2/12/75

Figure 8

---

## CHAPTER 5. Evolving The Graphs

---

bandwidth limitations that must be observed. Bear in mind that treble modulation goes to the sidebands in AM transmission and that the modulation level and frequency determine the amount of energy that appears in those sidebands. The response must be down 25 dB between 15 and 30 kHz. So if yours is a wideband system flat to 10 kHz and beyond, be sure that the program material that is broadcast does not contain sufficient energy above 15 kHz to exceed the allotted bandwidth.

A combination of normal transmitter frequency response rolloff above 10 kHz and lower relative program intensity at the high end usually result in a natural limitation of sideband energy, if the system is clean. If however, distortion products are generated, the plot thickens.

As an example, if 10 kHz modulation is accompanied by a 10% second harmonic, we wind up with a 20 kHz output at about -20 dB, already in excess of the -25 dB requirement. Modern program material with its excellent high frequency response makes clean audio a must, if excessively "wide sides" are to be prevented. After considering all of the factors involved, you can see how the response, distortion and bandwidth requirements are all interrelated.

It is interesting to note that the FCC distortion limit of 7.5% at high modulation levels can also be expressed as -26 dB. The second harmonic of 7.5 kHz would fall right on the doorstep of the 15 to 30 kHz -25 dB bandwidth requirement, so a distortion limit of more than 7.5% would really open the door for a related sideband problem. At this point it should be evident that if we wish to extend the frequency response of an AM broadcast station, very careful attention must be given to the distortion levels at the higher modulating frequencies.

Another interesting point is that the rules specify measurements for 100% modulation **if obtainable**. "Obtainable" is a rather complex term in this case because modulation limits don't usually appear in the form of an impassable wall. An AM transmitter usually exhibits a rapid increase in distortion as the limits of its modulation ability are approached. If the transmitter is clean to 95% and the limiter is normally adjusted to limit the modulation to a maximum of 95%, then it is permissible to make the full modulation measurements at 95% instead of 100%. If the same transmitter is normally operated right up to 100%, then it must meet the minimum FCC response and distortion standards at 100% modulation. If a transmitter with a 120% positive modulation capability is employed, it must not clip the positive half of the waveform below 120%. The limiter would be set to prevent the negative half from exceeding 100% in any case.

**The engineer conducting the equipment performance measurements really has quite a responsibility because the conditions under which the Proof is made also describe the limits of operation for that facility until the next Proof is made.**

Paragraph 73.47 requires that the frequency response and distortion measurements be plotted on graphs as well as recorded on the data sheet. If you pre-mark the graph forms with the FCC limits of response deviation and distortion, marginal performance will show up very quickly, because the curve will come to the limit line.

If your current performance is coming close to the limit in any respect, check past measurement data to see if better performance was obtained. If so, a detailed investigation of each segment of the system should be initiated as soon as possible. Such drifting performance could indicate degeneration of some part of the system which may cause the station to fall short of minimum standards before the next regularly scheduled equipment performance measurements are made. This is one of the reasons that the graphic representation of the station's performance is so useful.

Figures 9 and 10 are sample performance graphs illustrating typical performance for medium power AM stations. You will note that the curves here are really a series of straight lines connecting each measured response or distortion figure.

In this case, data was taken only at 50, 100, 400, 1k, 5k and 7.5k as required by paragraph 73.40, so these are the only points that are available to connect. It is usually quite satisfactory to limit the measurements to these six modulating frequencies. However, if you are interested in determining the exact shape of the roll-off's at either or both ends, more data may be taken between 50 and 400 or 5000 and 7500 so that a real curve may be traced.

If the response is flat within a couple of dB, however, it is obvious that the curve will be very close to a straight line. Any test series may be expanded to include voluminous data, but the FCC is more interested in low distortion figures and flat response than in a multiplicity of measurements.

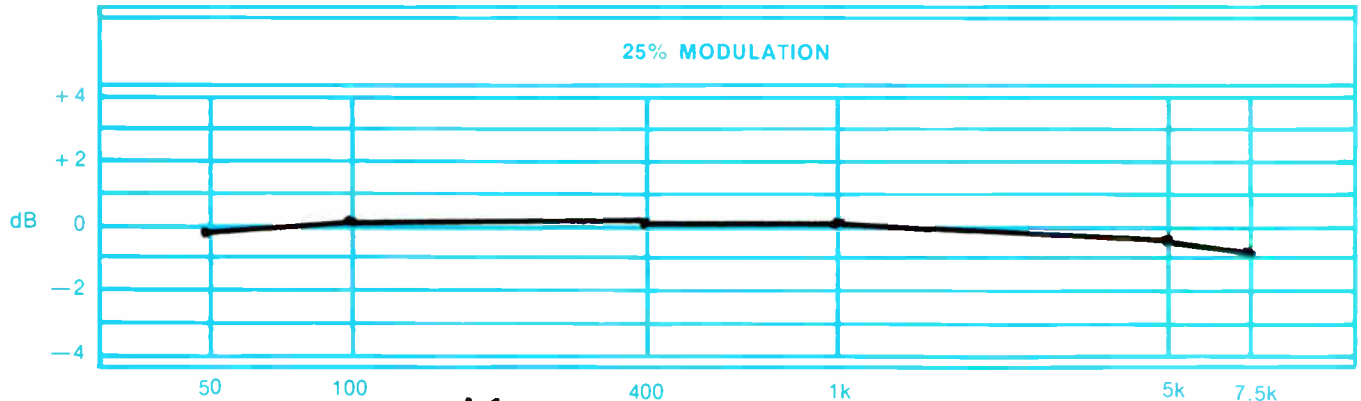
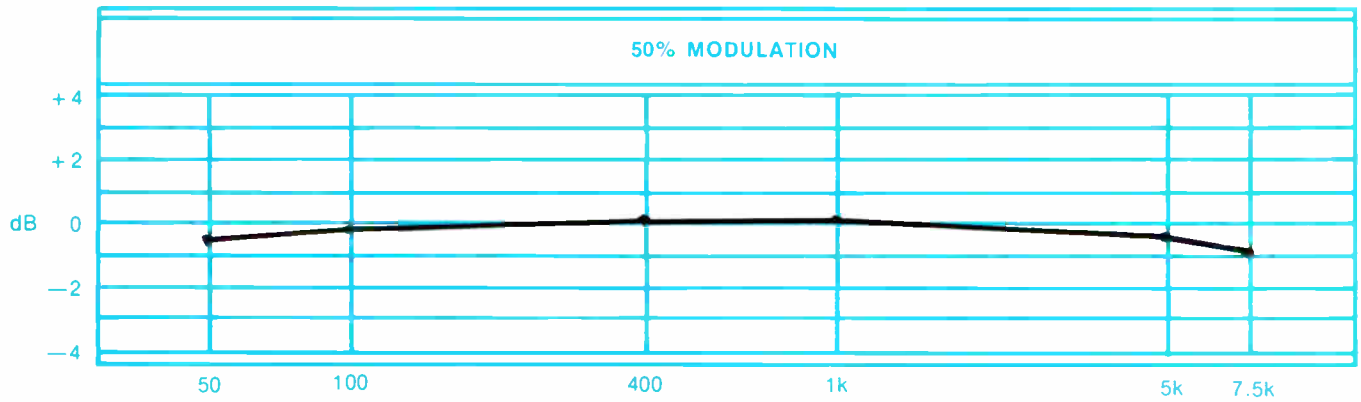
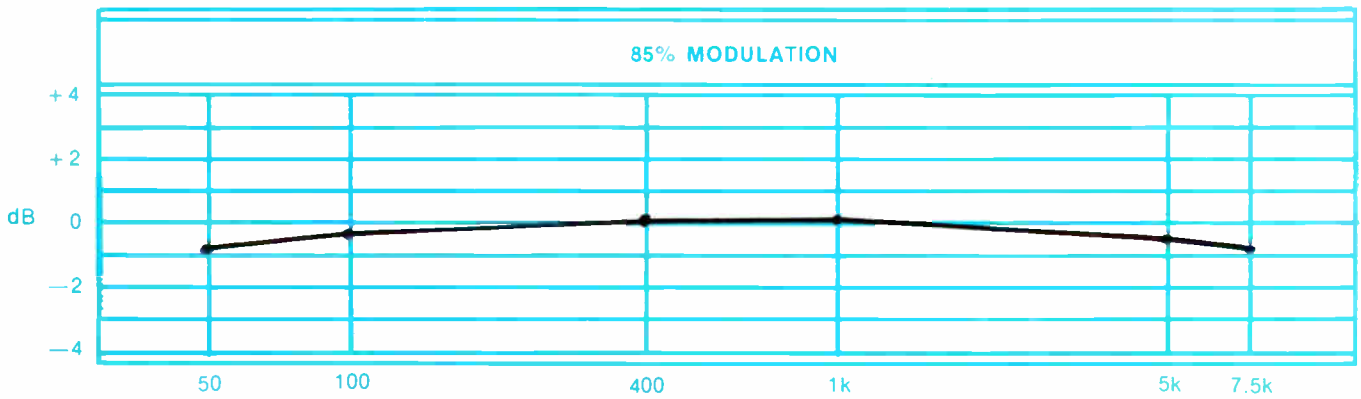
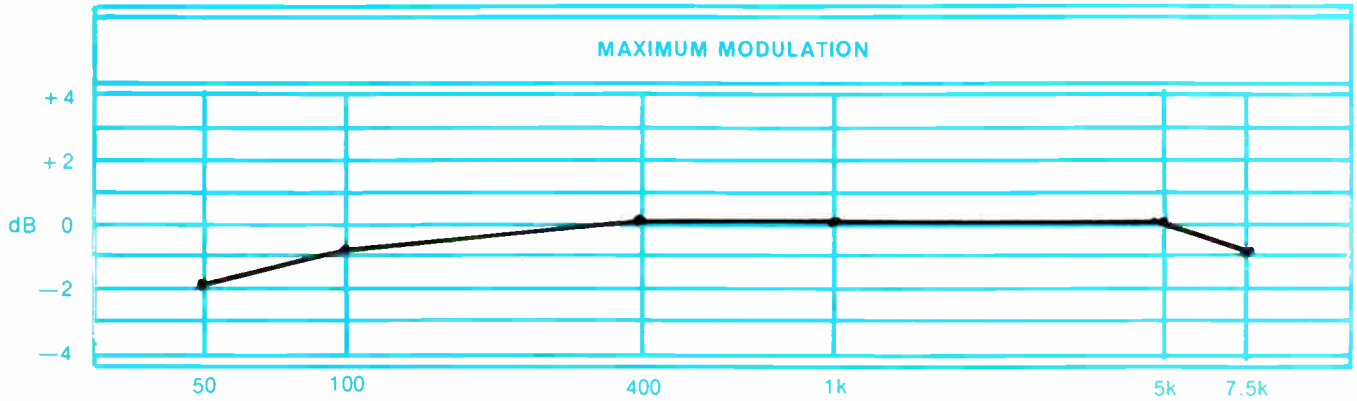

ALL TESTS PERFORMED BY Henry G. Ampere

DATE 2/12/75

Figure 9

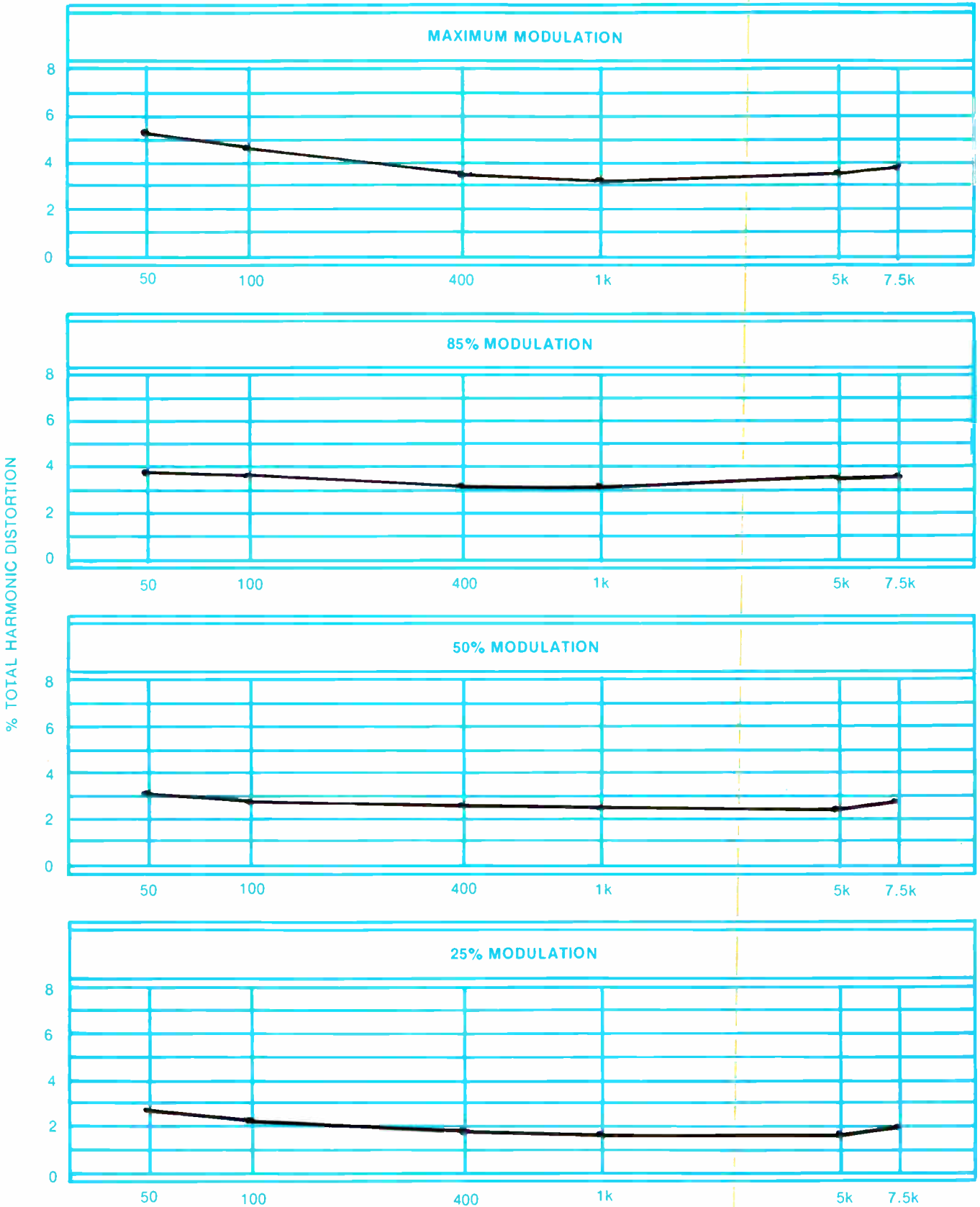

ALL TESTS PERFORMED BY

*Henry J. Ampere*

DATE

*2/12/75*

Figure 10

---

## CHAPTER 6.

# The Data Summary Sheet

---

The purpose of the data summary sheet is to provide an organized plan for recording the test results as they are obtained. The value of this organization will be appreciated later when we must draw from this collection of figures to assemble the graphs required by the FCC.

Before discussing the form itself, let's take a look at how the numerical data should be entered. Most electrical quantities can be recorded as 3 place decimals, although in some cases this is not possible or practical. For example, the response at 50 Hz may be read from the meter face as -2.5 dB, but the engineer who can see -2.54 dB has mighty keen vision indeed. A signal-to-noise ratio of 51.5 dB is quite easy to see however, so there is no way that one can specify the exact number of significant digits that the data should be carried to because the circumstances vary.

Figure 8 illustrates a sample data summary sheet, complete with typical data filled in. From this example you can see that it is possible to enter data directly onto the form as it is measured, and that is the way it is usually done. If you prefer to type in the numbers when the final form is prepared, remember that if a "work-sheet" is used to record the original data, it must be retained as a part of the records. If a typewriter is available at the transmitter then, of course, the original can also be the final form.

Although we believe that it is advisable to keep all original measurement data notes, the rules do not require this. The operating log rules (Sec. 73.113(c)) do require

that data in rough form later transcribed in the operating log be kept.

The frequency response section contains two columns, one for the original audio generator output voltage settings and another for the actual response deviation figures. It is important that any possibility for error in transferring the test results from the meter face to the data sheet be eliminated, and that is the reason for recording the audio generator output settings. While it is not difficult to figure out the response deviations mentally as the data is measured, an error in addition or subtraction would never be discovered and erroneous data would be recorded. By recording the generator output, the engineer is free to concentrate on the tests at hand and worry about the math later. There is also a record of the original data that can be double-checked with the deviation figures to insure accuracy.

Filling in the distortion figures is straightforward, and, as we'll see in the next chapter, can be done at the same time the response data is gathered. When recording distortion figures of less than 1% or response deviations of less than 1 dB, it is customary to place a 0 to the left of the decimal point to preclude any question about whether the number is whole or fractional. In a group of numbers, -.2 dB doesn't look too different from -2 dB but -0.2 dB is at once recognizable as a different animal. See Figure 8 for an illustration of how typical values would be recorded on the form.

Much more complex and technically ominous forms for gathering the test data could be evolved, but what the FCC is really looking for is carefully measured and accurately recorded test results without unnecessary garnishment. While good engineering practices should be observed, it is not necessary that each page be a notarized affidavit with all times converted to Greenwich Meridian.

A frequent problem encountered is the failure of operators making Equipment Performance Measurements to log the work in the maintenance log together with a notation of any repairs or adjustments made prior to, or during the measurements.

10 00 1.5K  
2170 12  
2/2/20

---

## CHAPTER 7.

# How To Check For Spurious Radiation

---

Paragraph 73.47(5) of the FCC rules states that the P.M. must include measurements or evidence that spurious radiations, including RF harmonics, are suppressed sufficiently to avoid objectionable interference to other radio services. This part of the regulations is not specific, and you may wonder how much interference is objectionable.

For some guidelines, let's refer to paragraph 73.40(a)(14) which states that any emission removed from the carrier by 75 kHz or more must be attenuated up to 80 dB. We can assume therefore, that if our facility is interfering with the operation of another radio service and the interfering spur is not at least 80 dB below the carrier, then the burden of solving the problem is ours. In certain situations the FCC may require even greater attenuation and external filters may be indicated.

For the purpose of the P.M., the engineer is primarily required to demonstrate that the system has not degenerated, and where actual numerical results have not been requested by the Commission, tests made with a communications type receiver are usually acceptable. For new installations being "proofed" for the first time, however, actual signal strength measurements are preferred. In any case, the Commission reserves the right to request whatever data is necessary to establish that the facility is operating within the limits set forth in the rules.

When using a communications receiver to check for harmonics and spurs, we must be absolutely sure that the receiver itself is not generating any intermod components within its circuitry. This situation arises when excessive signal input is applied to a receiver, causing some portion of the RF/IF chain to overload and generate spurs. At no other place in the world is a receiver more likely to be overloaded than at a transmitter site! If an extremely well-shielded receiver and input attenuator are available, valid measurements may be made quite close in, depending upon the transmitter power and frequency, but it is usually better to set the unit up about 1/2 to 1 mile from the antenna. Obviously, the receiver sensitivity, antenna gain (or loss, as the case may be), transmitter power, antenna radiation efficiency and distance from the antenna all combine to determine the actual voltage at the receiver input. So, there is no set rule for setting up the equipment for these tests,

particularly since the overload point varies considerably from receiver to receiver. Fortunately though, it is usually not too difficult to tell if the receiver is overloaded.

If reducing the input to the unit causes the "spur" to rapidly decrease in strength or disappear as though a threshold had been reached, the signal is probably the result of receiver overload. In most cases, turning down the RF gain will not prevent overload and should not be depended upon to do so. Only an attenuator at the antenna input can prevent overload of the first RF amplifier. On the other hand, it is not permissible to operate the unit 30 miles from the transmitting antenna either, since the ability to determine possible interference to nearby services (near the transmitter) would be dubious, at best. Rather large harmonics could be present but below receiver sensitivity at that distance during daylight hours.

Another reason for making checks or measurements of harmonic radiations near the station is that the ground loss attenuation increases with increase in frequency. (Interference from harmonic radiation via sky wave has been observed on harmonics that were not heard several miles from the station during Equipment Performance Measurement checks.)

Once a satisfactory system of reception has been set up, the receiver should carefully be tuned slowly across each band, stopping for a crystal calibrated check at each harmonic of the station's carrier frequency. If you think you have picked up a spur, cut the carrier and see if it disappears. If it does not, then the signal is being generated someplace else and can be disregarded. Be sure that all portions of the system are cut when you cut the carrier, including the exciter, if it is a solid state unit. With some transmitters it may be necessary to cut the filament switch off to disable the exciter.

The most likely places to pick up a signal would be at the second and third harmonics. Almost all transmitters have tunable second and third harmonic traps, so correcting excessive output at these frequencies is generally quite easy. Follow the manufacturer's instructions carefully and to the letter. Some of these traps are not designed to be tuned at full power and the manufacturer may specify that an RF generator be used to check the resonance of these circuits. If no notch can be obtained by tuning the trap for the harmonic in question, look for an open capacitor in the circuit.

If the harmonic can be nulled, but not completely, the transmitter may be generating more second or third harmonic than is normal and a check of the transmitter tuning is indicated. Continue to check for spurious emissions up to the limits of the receiver's frequency range, which should be at least 10 times the station's carrier frequency.

**BROADCAST ENGINEERING**  
**OFFICIAL PROOF FORM**

SPURIOUS EMISSION TESTS:  
 STATION WXYZ

RECEIVER OR FIELD STRENGTH METER EMPLOYED (TYPE & MANUFACTURER) Hammarlund 140X  
 SERIAL # 125 719 42F

RANGE OF FREQUENCIES MONITORED 500 hz TO 30 mhz.

RESULTS OF TESTS No Spurious Emissions Audible at any Frequency

**HARMONIC OUTPUT CHECKS**

| HARMONIC # | FREQUENCY | RESULTS           |
|------------|-----------|-------------------|
| 2          | 1.2 MHz   | No Audible Output |
| 3          | 1.8 MHz   | " " "             |
| 4          | 2.4 MHz   | " " "             |
| 5          | 3.0 MHz   | " " "             |
| 6          | 3.6 MHz   | " " "             |
| 7          | 4.2 MHz   | " " "             |
| 8          | 4.8 MHz   | " " "             |
| 9          | 5.4 MHz   | " " "             |
| 10         | 6.0 MHz   | " " "             |

ADDITIONAL TESTS IF REQUIRED: \_\_\_\_\_

ALL TESTS PERFORMED BY Henry J. Ampere DATE 2/12/75

STATION \_\_\_\_\_

Lined area for notes or test results.

Engineer \_\_\_\_\_

Lic. No. \_\_\_\_\_

Date \_\_\_\_\_



**BROADCAST ENGINEERING.**

**OFFICIAL PROOF FORM**

DATA SUMMARY SHEET:  
STATION \_\_\_\_\_

|                        | MOD FREQ. (Hz) | GEN OUTPUT (dB) | RESP DEV. (dB) | DISTORTION(%) | CARRIER SHIFT | NOISE |
|------------------------|----------------|-----------------|----------------|---------------|---------------|-------|
| MAX. MODULATION = 100% | 50             |                 |                |               |               |       |
|                        | 100            |                 |                |               |               |       |
|                        | 400            |                 |                |               |               |       |
|                        | 1000           |                 |                |               |               |       |
|                        | 5000           |                 |                |               |               |       |
|                        | 7500           |                 |                |               |               |       |
| 85% MODULATION         | 50             |                 |                |               |               |       |
|                        | 100            |                 |                |               |               |       |
|                        | 400            |                 |                |               |               |       |
|                        | 1000           |                 |                |               |               |       |
|                        | 5000           |                 |                |               |               |       |
|                        | 7500           |                 |                |               |               |       |
| 50% MODULATION         | 50             |                 |                |               |               |       |
|                        | 100            |                 |                |               |               |       |
|                        | 400            |                 |                |               |               |       |
|                        | 1000           |                 |                |               |               |       |
|                        | 5000           |                 |                |               |               |       |
|                        | 7500           |                 |                |               |               |       |
| 25% MODULATION         | 50             |                 |                |               |               |       |
|                        | 100            |                 |                |               |               |       |
|                        | 400            |                 |                |               |               |       |
|                        | 1000           |                 |                |               |               |       |
|                        | 5000           |                 |                |               |               |       |
|                        | 7500           |                 |                |               |               |       |

ALL TESTS PERFORMED BY \_\_\_\_\_ DATE \_\_\_\_\_

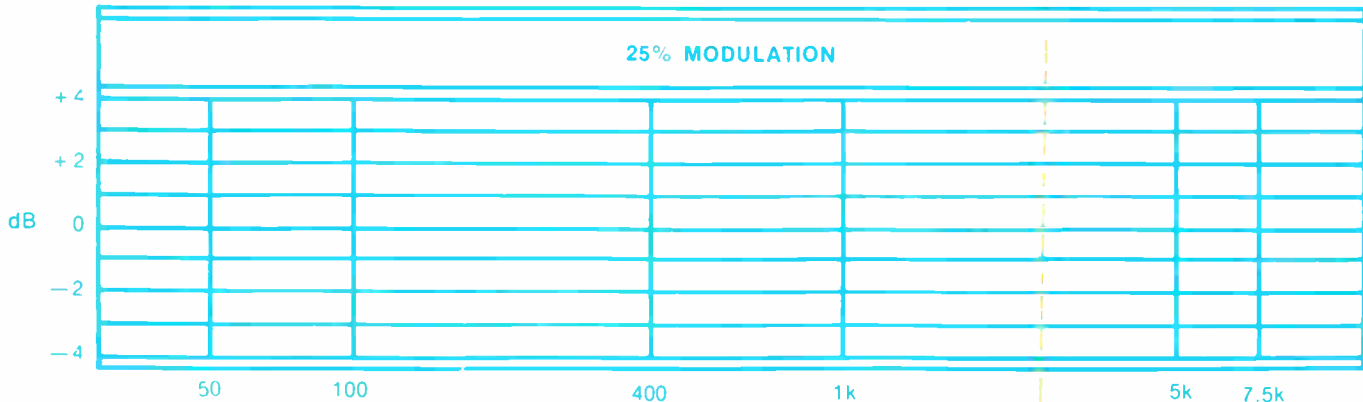
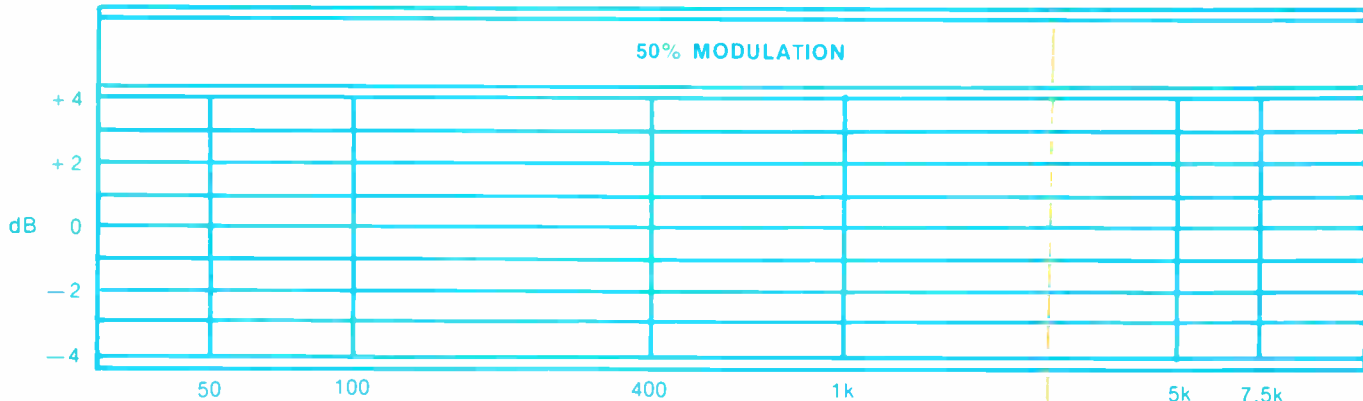
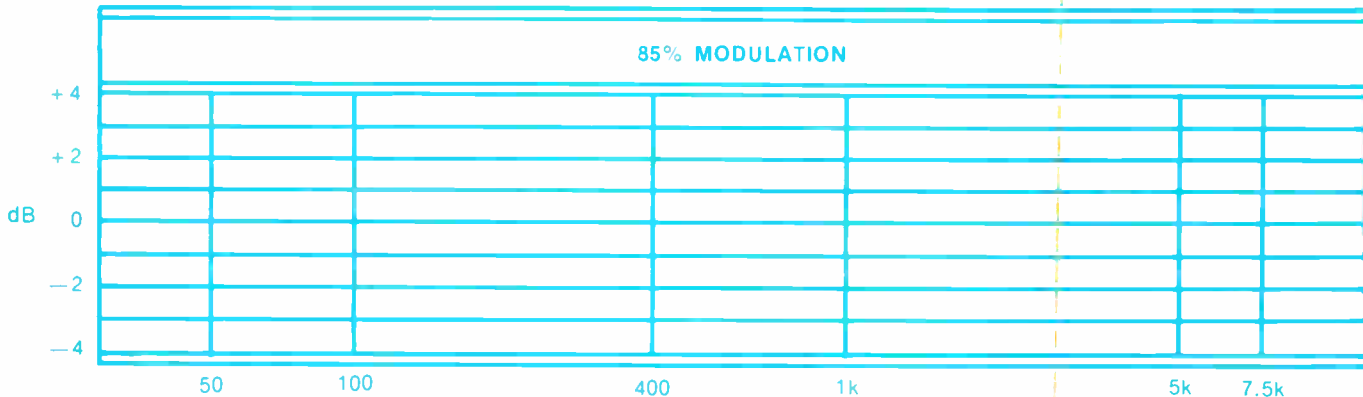
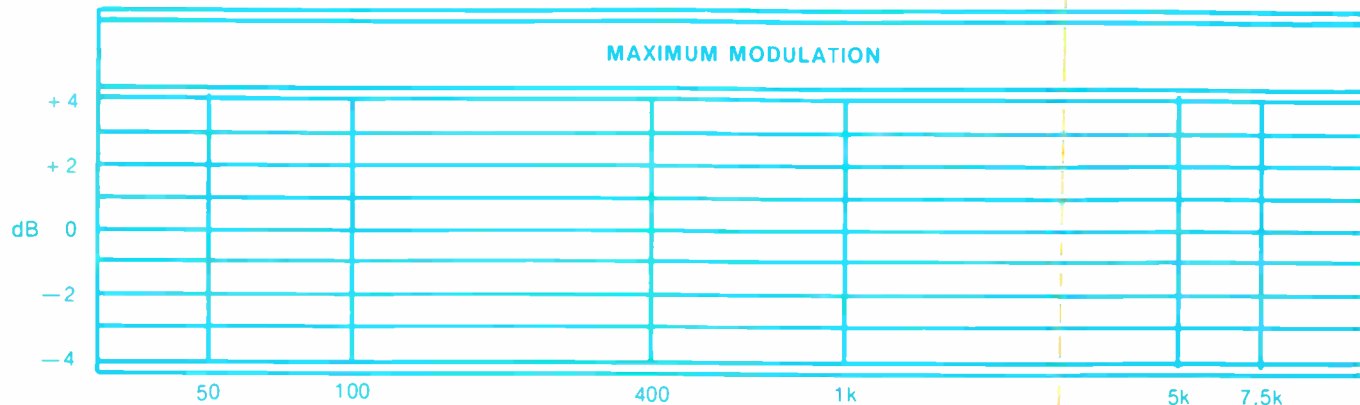

ALL TESTS PERFORMED BY \_\_\_\_\_ DATE \_\_\_\_\_

% TOTAL HARMONIC DISTORTION

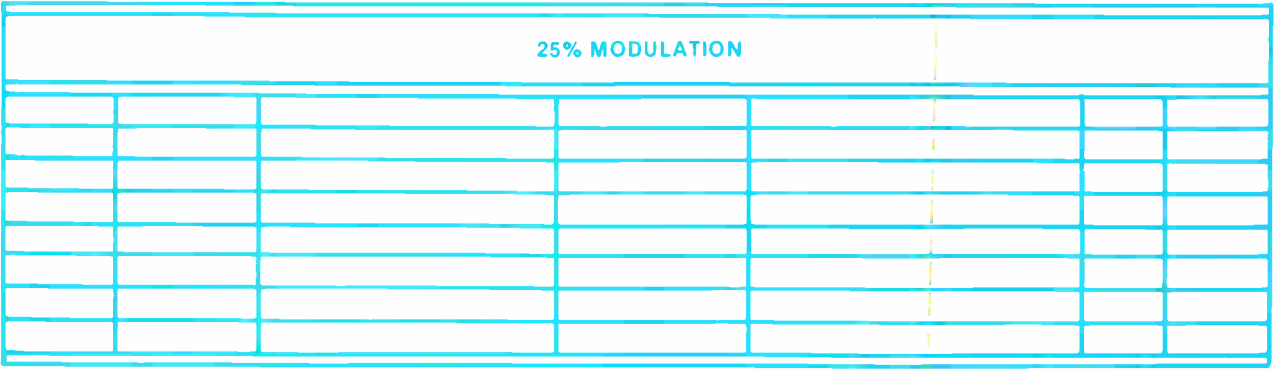
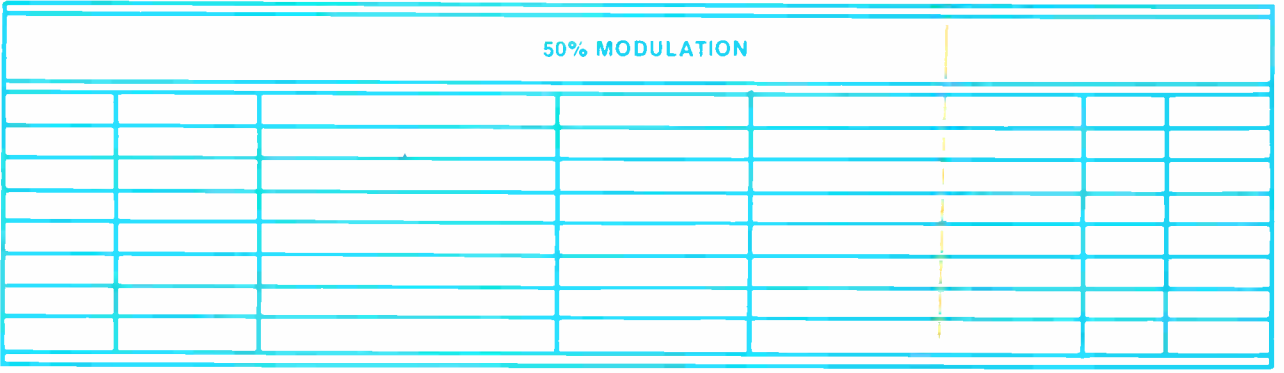
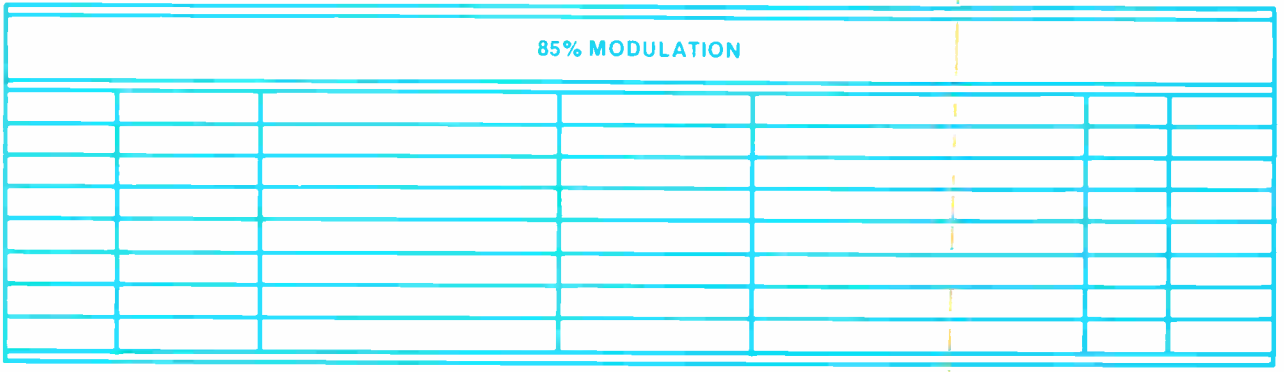
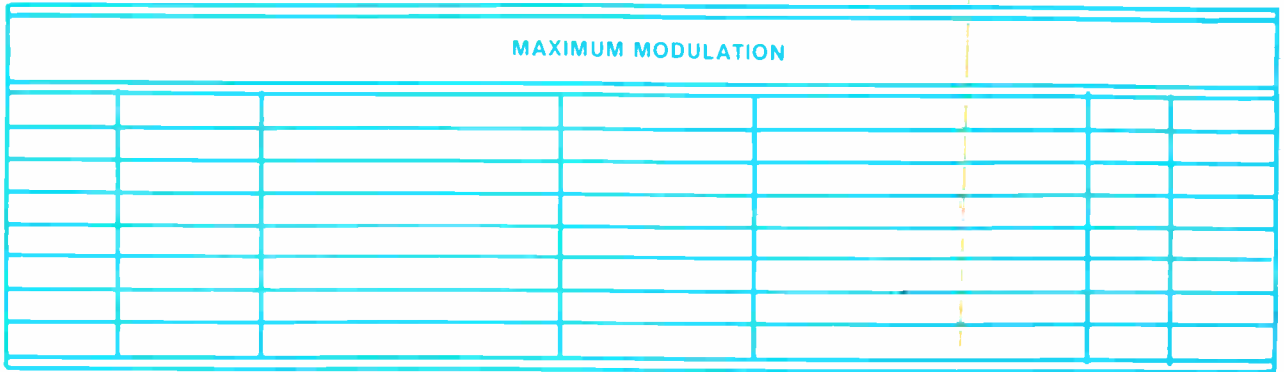

ALL TESTS PERFORMED BY \_\_\_\_\_ DATE \_\_\_\_\_

**BROADCAST ENGINEERING.**  
**OFFICIAL PROOF FORM**

SPURIOUS EMISSION TESTS:  
STATION \_\_\_\_\_

RECEIVER OR FIELD STRENGTH METER EMPLOYED (TYPE & MANUFACTURER) \_\_\_\_\_

SERIAL # \_\_\_\_\_

RANGE OF FREQUENCIES MONITORED \_\_\_\_\_ kHz TO \_\_\_\_\_ mhz.

RESULTS OF TESTS \_\_\_\_\_

**HARMONIC OUTPUT CHECKS**

| HARMONIC # | FREQUENCY | RESULTS |
|------------|-----------|---------|
| 2          |           |         |
| 3          |           |         |
| 4          |           |         |
| 5          |           |         |
| 6          |           |         |
| 7          |           |         |
| 8          |           |         |
| 9          |           |         |
| 10         |           |         |

ADDITIONAL TESTS IF REQUIRED: \_\_\_\_\_

ALL TESTS PERFORMED BY \_\_\_\_\_ DATE \_\_\_\_\_