

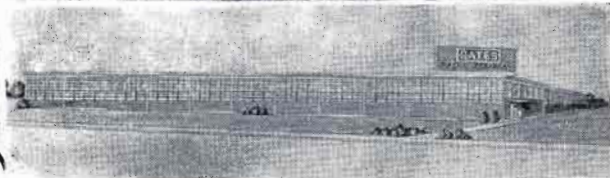

GATES FACTORIES

Located in the near geographic center of the United States, our Hampshire Street plant is on a bluff overlooking the mighty Mississippi River. Here are the offices, development laboratories, engineering, special equipment, cabling and audio construction departments.



Our Broadway factory, built in 1953, is one of the electronic industry's most modern manufacturing plants. Site of over 7 acres allow ample room for field testing and personal recreation. Here heavy transmitters are manufactured—here are the machine shops, cabinet making and painting departments.

GATES RADIO COMPANY, QUINCY, ILLINOIS, U. S. A.



Stock Carrying Branches

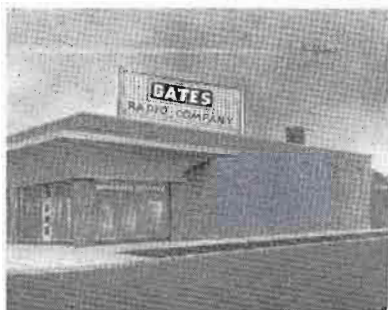

Houston, Texas

Located at 2700 Polk Avenue, telephone Capitol 8-8536, TWX No. HO 456, serves the south central and southwestern areas of the United States. Carries full inventory of many Gates equipments and that of major suppliers.

Atlanta, Georgia

Located at 1133 Spring Street, N. W., telephone Elgin 0369, TWX No. AT 796, serves the entire southeastern area with a fine complement of Gates and jobbed materials for the broadcast and industrial fields.



Los Angeles, California

Located on popular Sunset Boulevard, address 7501, telephone Hollywood 2-6351, TWX No. LA 1210, serves the far west with a generous inventory of Gates and jobbed items for the broadcast and industrial electronics field.

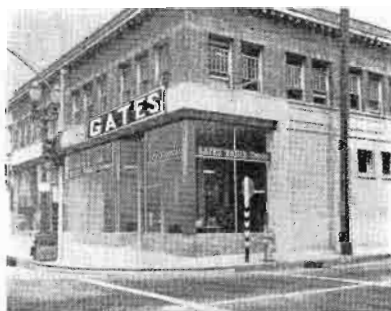

Washington, D. C.

The oldest Gates district sales office, near the FCC, Washington consultants and attorneys. Located in the Warner Building, 13th & E Street, N. W., telephone Metropolitan 8-0522, TWX No. WA 759.

New York City

Next door to Grand Central Terminal at 51 E. 42nd Street, this Gates office serves the world's largest city, New York state and the New England states. Telephone Murray Hill 7-7971, TWX No. NY 1-4811.

Sales Policy and Terms

PRICES:

All prices are the lowest net prices to our customers; that is, discounts, where applicable, have already been deducted. Every effort is made by Gates people to purchase at the lowest prices and pass the savings on to our customers. For the first time in an industrial electronics catalog, prices have been shown, in the large part, on the catalog page. We realized that this could cause complications; and, therefore, ask our customers to understand that price changes over the life of such a comprehensive catalog are inevitable. These price changes could be either upward or downward. Gates will not fill an order if there is a price increase of any consequential amount without first notifying the customer.

SHIPPING:

Terms are F. O. B. Quincy, Illinois. In some instances to provide fast service, shipment may be made directly from the vendor's factory. In this case, shipping terms are F. O. B. vendor's factory. Certain items in this catalog are shipped freight paid. In this case, it is noted adjacent to each item.

CREDIT:

We solicit open account transactions for our regular terms of net 30 days. In some instances where urgent shipment is desired and credit information is not speedily available, or for other reasons, shipment will be made on a C. O. D. basis. Any new customer who desires an open line of credit is cordially invited.

GUARANTEE:

Gates manufactured products are guaranteed for one year, with certain major components in transmitters, etc., guaranteed on a pro rata basis for two years, tubes and certain moving parts excepted. A copy of the very extensive and liberal Gates guarantee will be supplied on request. Products not manufactured by Gates are subject to the manufacturer's guarantee. Installation supervision or field service is excluded from both guarantee and selling price.

EXPORT:

In Canada all Gates products are sold by the Canadian Marconi Company, home office in Montreal and branch offices throughout Canada. Overseas export sales are handled by the Gates Radio Company, with offices in New York City as well as Quincy, Illinois. For handling export transactions, all shipments out of continental United States are net cash F. O. B. Quincy, Illinois. Where establishing letters of credit, sufficient extra should be allowed for freight, lighterage, insurance and handling charges. Ocean shipments are subject to 2½% increase on the net selling price for export packing. JAN packing specifications are also additive.

MODIFICATIONS:

The rapidly advancing technology of the electronic industry demands continued product improvements. As a result, Gates reserves the right, on both Gates manufactured products and those of manufacturers whom Gates represents, to alter the product wherein said alteration does not reduce either performance or construction quality. Where said alterations effect a price increase, customer will be notified. Gates also reserves the right to withdraw any item listed herein from sale, and without notice.

OTHER CONDITIONS:

Though every effort is made to keep all Gates personnel throughout the world fully advised as to changing conditions, it is necessary that all orders are subject to final acceptance at the home office at Quincy, Illinois. Items damaged in transportation should immediately be called to the attention of the delivering carrier of the transportation company for payment of damages. A copy of the report of damaged material should be sent to our home office within 5 days so that assistance, when requested, can be rendered our customers in payment of damage claim to them. Gates will make every effort to deliver promptly, and is proud of its policy of fast shipments, often on items normally not stocked by others. Failure to deliver promptly for any reason shall not hold Gates liable for damage of any kind, nor shall delays in delivery relieve the purchaser of his obligation of performance.

The aim of the Gates organization is to supply the finest equipment available at the lowest market prices, and in the speediest way possible.

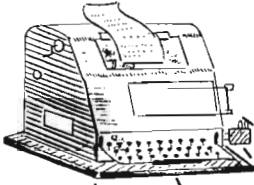

GATES SERVICE

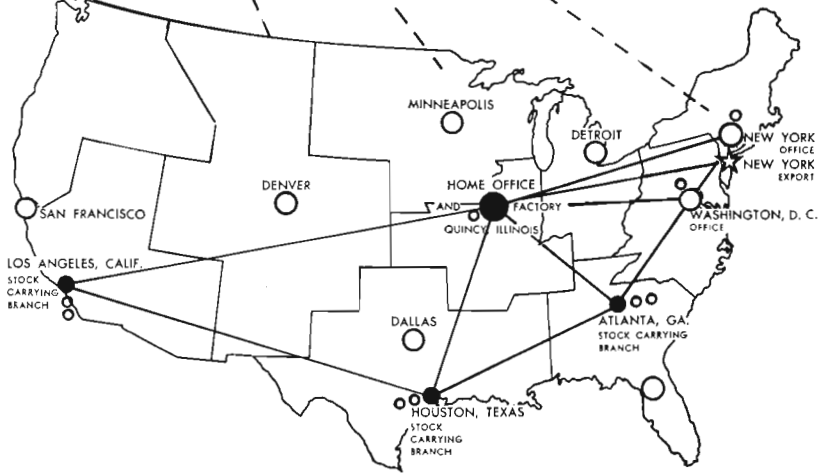

For Better Service...
 All Gates Offices are
 Teletypewriter Interconnected

- — GATES Stock Carrying Points
- — GATES Field Engineers
- ☆ — International Office



GATES RADIO COMPANY

Manufacturing Engineers Since 1922

QUINCY, ILLINOIS, U. S. A.



Your New Gates Catalog

We have tried a new approach in large equipment catalogs. You will note the page size is a little smaller, but each page is concise, and often is devoted to only one subject. Our hope has always been to produce a catalog easy to read, combined with a fine enamel stock and letter press printing — so nice you will always want to keep it.

Our aim in serving the industry is to have available equipment and materials you need. This catalog lists, of course, an abundance of Gates manufactured products. It also displays a generous number of items, large and small, we feel are of a quality that will complement the high standards we have always attempted to maintain.

Prices shown are net prices to the user. This is an industrial catalog. Discounts often given have been deducted before pricing.

Yours very truly,

GATES RADIO COMPANY

PRICE \$3.50

GATES RADIO COMPANY
1133 Spring Street, N. W.
Atlanta, Georgia
Telephone: Elgin 0369

GATES RADIO COMPANY
51 E. 42nd Street
New York 17, N. Y.
Telephone: Murray Hill 7-7971

CANADIAN MARCONI COMPANY
2442 Trenton Avenue
Montreal 16, Quebec, Canada
Telephone: Atlantic 9441

GATES RADIO COMPANY
2700 Polk Avenue
Houston, Texas
Telephone: Capitol 8-8536

GATES RADIO COMPANY
Warner Bldg., 13th & E Street, N. W.
Washington 4, D. C.
Telephone: Metropolitan 8-0522

GATES HAS DIRECT FIELD SALES ENGINEERS strategically located throughout the United States. One is always near you. Wire or write the office nearest you and he will call. In Canada, the Canadian Marconi Company has offices throughout Canada. Wire them where personal consultation is desired.

GATES RADIO COMPANY
7501 Sunset Blvd.
Los Angeles 46, California
Telephone: Hollywood 2-6351

ROCKE INTERNATIONAL CORP.
13 East 40th Street
New York 16, N. Y.
Telephone: Murray Hill 9-0200

GATES RADIO COMPANY — QUINCY, ILLINOIS, U. S. A.
MANUFACTURING ENGINEERS SINCE 1922

GATES

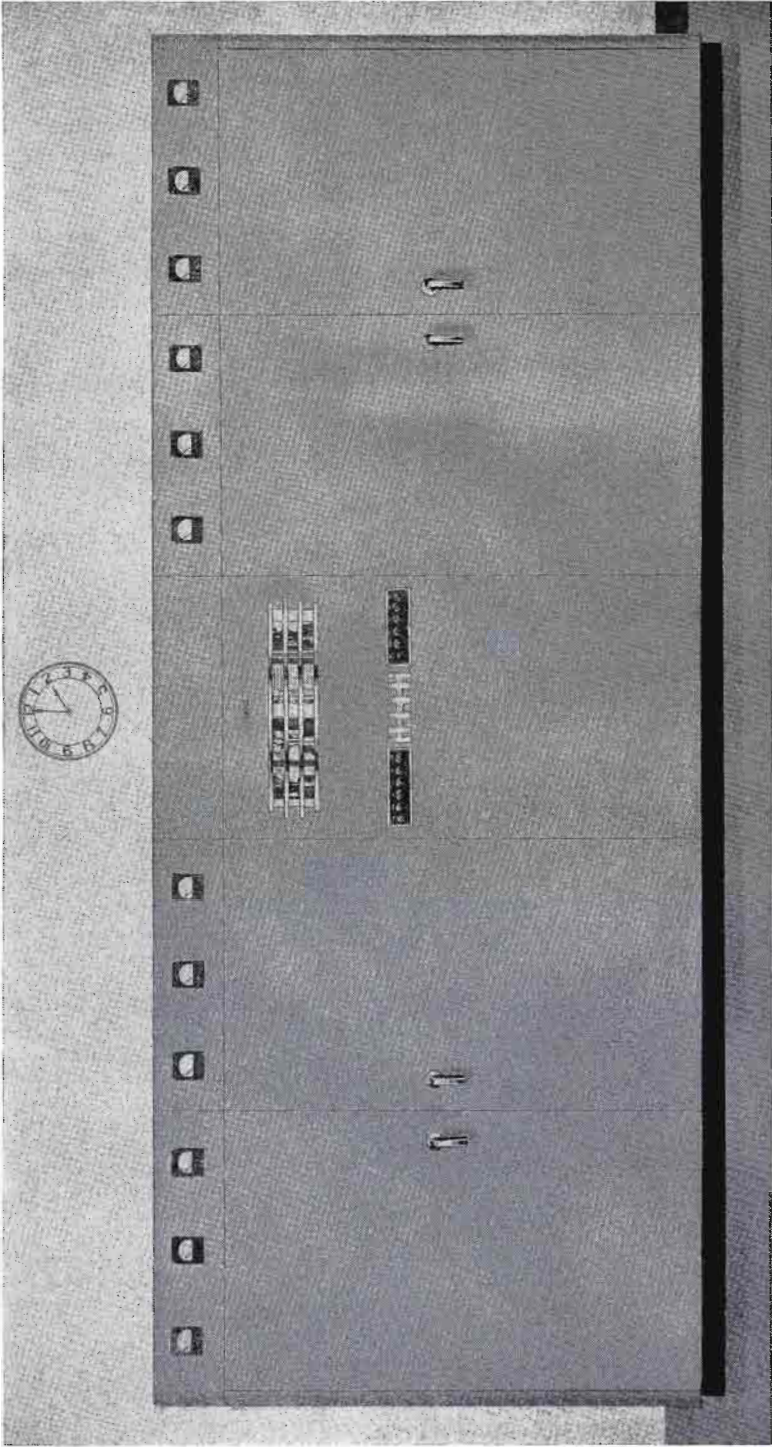

Gates 20KW Radio Broadcast Transmitter

20KW RADIO BROADCAST TRANSMITTER

This series of 20,000 watt transmitters are available in both medium and short wave models.

Model BC-20B: A complete broadcast transmitter for operation between 540-1600 Kc.

Model HF-20B: A short wave broadcast transmitter for operation between 4-22 Mc.

Model HF-20BX: A short wave 4-22 Mc telephone and high speed telegraph transmitter with provision for frequency shift keying adaptation.

Model HF-20TX: A CW transmitter only with high speed keying and provision for frequency shift keying.

All modulated models are nearly identical, the difference being in the radio frequency cubicle and its natural variance between medium wave and short wave design. The telegraph model is also the same other than the modulator has been removed.

CONSTRUCTION

Five cubicles join together to house the 20KW radio frequency, audio frequency, protective and power supply units. The only external components are the two main power transformers, modulation transformer and reactor. These units are oil filled and may be installed either in the building or on a protected platform outside the building. The transmitter is dead front, and all front doors may be opened without disrupting the carrier. No inter-cubicle cabling is required when installing. Each of the five cubicles is completely assembled and wired. These cubicles

bolt together speedily. At the base of each cubicle are barrier terminal boards; and wiring of all cubicles together for an operating transmitter is accomplished by means of short jumpers between these terminal boards. Floor space, exclusive of external units mentioned above, is 210" wide, 78" high and 49" deep. Door swing of 40" should be allowed for both front and back doors. Finish is in hand rubbed medium gray with trimmings in chrome, brushed aluminum and anodized black.

These large variable vacuum capacitors offer wide tuning range and high insulation in the short wave models.

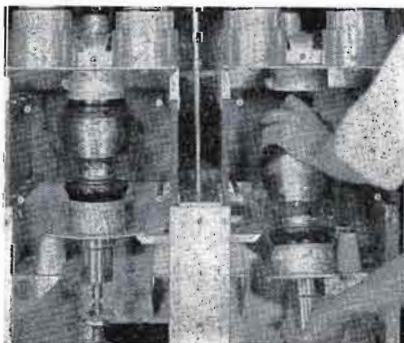

This is the 11-18 Mc tank coil. It is of the slide-in, latch-on type and may be changed to another size in seconds.

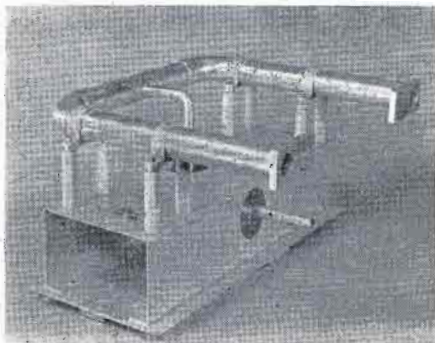

GATES 20,000 WATT TRANSMITTERS

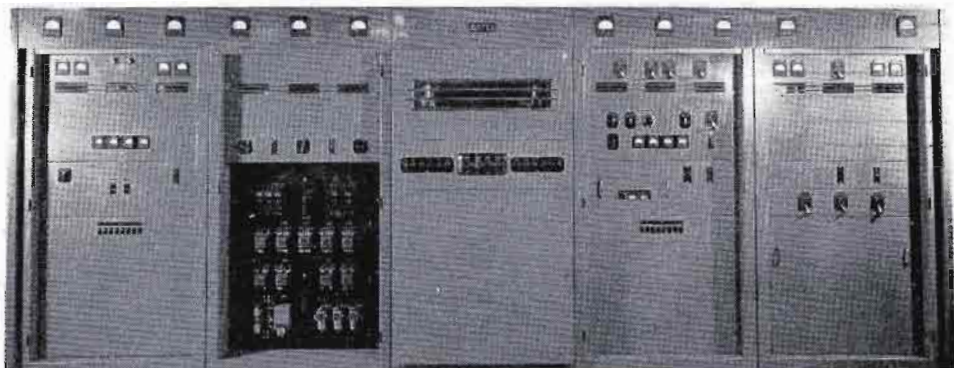

Front doors have been removed for the above illustration. From left to right are: the modulator cubicle, protective relay/low voltage rectifier cubicle, protective relay/high voltage cubicle, RF driver cubicle and power amplifier/output coupling cubicle.

Gates transmitters have long been known for their rugged construction and fine workmanship. The rear view, doors removed, well illustrates this and also the ease in servicing and maintenance through proper location of sub-units. In many instances the technical personnel may actually walk inside the transmitter to reach every part—large or small.

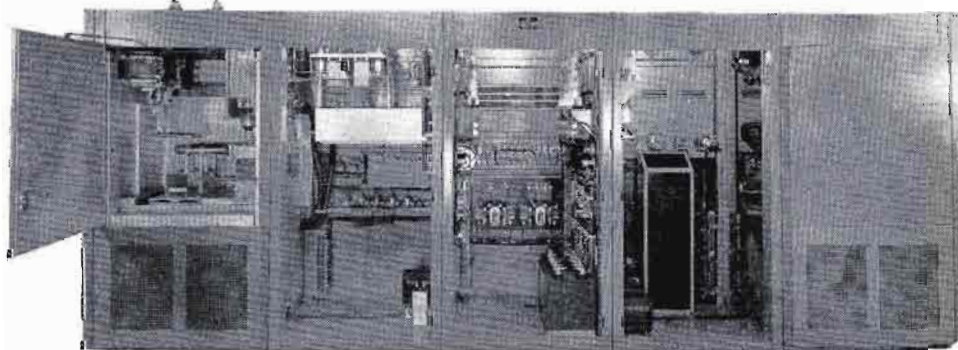

20KW Medium or Short Wave TRANSMITTER

OSCILLATOR: A quickly detachable unit. Both medium and short wave models employ a Colpits oscillator and first IPA stage which tune the entire band of either 540-1600 Kc, or 4-22 Mc. The medium wave oscillator unit has provision for two JK57M temperature controlled crystal holders, maintaining 0.005% or better accuracy. — The short wave oscillator unit has four crystal positions, all temperature controlled for 0.005% accuracy and crystals selectable from the front panel. Provision is made for attaching a frequency shift keyer or external variable oscillator. Both frequency shift keyers and variable oscillators are listed elsewhere in this catalog (see Index).

RADIO FREQUENCY: Including the oscillator, there are five stages. The second IPA-doubler is a 6146 tube self-neutralized, the RF driver, a pair of 4-250A tubes self-neutralized, and the final power amplifier contains four 3X2500F3 tubes in push-pull parallel. On short wave models, output is balanced into a 300-800 ohm line. On broadcast models, output is from 50 to 270 ohms, as ordered. The entire operation is continuously variable from the front panel on the short wave models, except the power amplifier tank circuit. For this service, Gates has developed

the latch-on tank coil system and tank coils may be changed in a matter of seconds, eliminating all complicated tuning and band change mechanisms in the high power stage. Veeder counter type dials are used on all variable coils for split turn logging for frequency change. Of particular importance is the use of the thoriated tungsten filament 3X2500F3 tubes in the power amplifier, assuring long tube life and very low noise.

AUDIO FREQUENCY: Four stages with push-pull parallel Class B 3X3000A3 tubes as modulators. Feedback is employed as an adjunct for improved noise reduction and less distortion. However, these transmitters will meet all acceptable standards without feedback, thus feedback is not employed as a substitute for component size but to further improve the excellent performance possible without feedback.

METERING: No multi-metering is employed, and a full meter complement is supplied to measure all necessary circuits both for tune-up and general operation. Individual plate current meters are provided for each of the power amplifier and modulator tubes. There are 29 meters.

(Continued next page)

Floor plan of 20KW medium or short wave models.

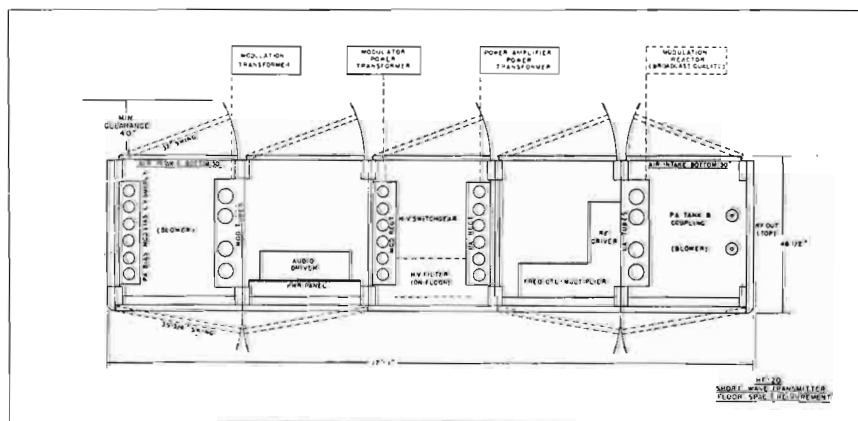

GATES 20KW PHONE/CW TRANSMITTERS

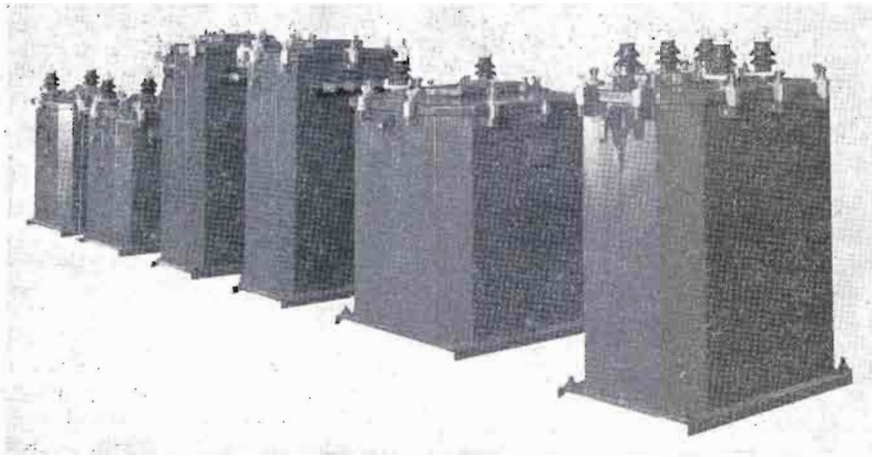

Heavy oil filled power-modulation components provide dual power supplies for both power amplifier and modulator.

PROTECTION: Gates engineers have provided protection to the point that no power consuming circuit of importance has been overlooked. Primary thermal breakers are inserted in all main primary lines. Individual supervisory overload relays are incorporated for, not only the transmitter main overload, but also for separate protection; exciter failure, air failure, RF driver, power amplifier, audio driver and modulators. Included are secondary relays for door interlock and air cooling interlock. Automatic condenser discharge relay switch immediately discharges the main filter capacitors when the door interlocks are disengaged.

RECYCLING: Automatic recycling relay controls automatically where the carrier is disrupted, and attempts to reset the carrier four times before remaining off. Many times carrier interruption is caused by static discharges across the transmission line or tower base and this recycling feature is indispensable.

POWER SUPPLIES: Five major power supplies deliver plate and bias voltage to the HF-20 transmitter. Featured are the two complete high voltage supplies. One is used for the radio frequency power amplifier and the other for the modulators. The resulting almost perfect regulation is quickly recognized by the engineer. Likewise, in case of failure of one power supply, the remaining one can be bussed in, operating the transmitter on re-

duced power until repairs are made. Each of these power supplies are full wave, three phase, six tube supplies. Other individual supplies provide modulator bias voltage, power amplifier bias voltage and intermediate voltage for driver stages. All power supplies are generously protected by circuit breakers, overload relays, etc. (See Protection above).

KEYER: In the HF-20BX and HF-20TX models, electronic keying is through an 812A tube so biased that with key closed no current is drawn. This operates in conjunction with the oscillator and IPA doubler stage. Keying speeds up to 400 WPM are possible, with excellent square top wave form.

LOGGING: Veeder counter to 1/10 turn for operation of variable coils and variable vacuum condensers, and calibrated dials assure an accurate frequency calibration for quick frequency change of the short wave model.

PERFORMANCE: The design of this 20KW series is for the highest commercial standards. Around the clock operation, high efficiency, stability, low carrier shift, excellent power regulation and sterling audio performance in the broadcast models are expected qualities. Nothing has been spared to make operation reliable in warm, humid climates or cold, arctic conditions. Full performance specifications are on the following pages.

20KW FUNCTIONAL DIAGRAM

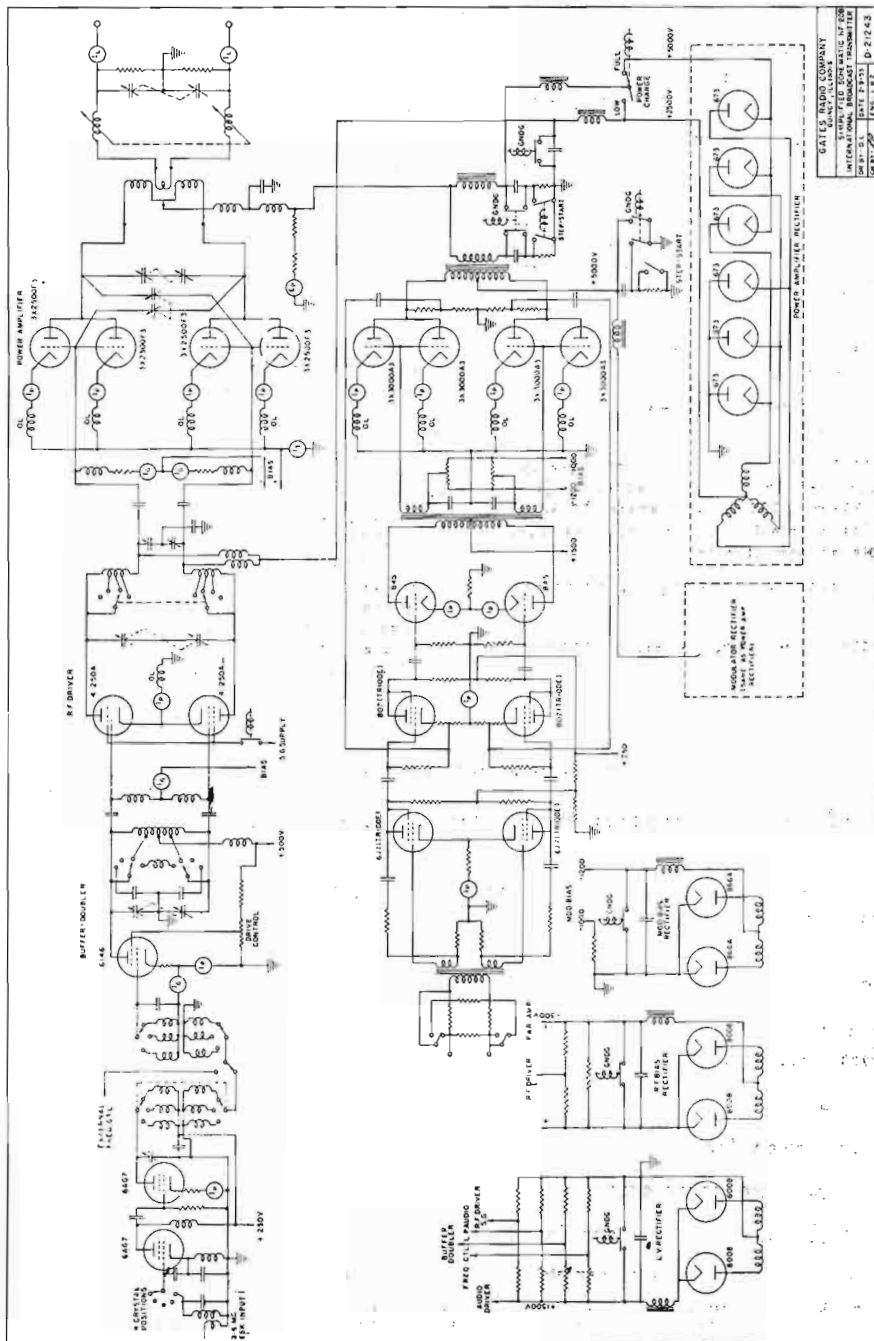

Functional diagram of the HF-20B short wave broadcast transmitter. The medium wave 540-1600 Kc varies slightly in PA stage and oscillator design. Extensive relay/protective system is eliminated in this drawing for clarity of circuitry.

20KW SPECIFICATIONS—ORDERING DATA

SPECIFICATIONS

FREQUENCY RANGE: BC-20B: 540-1600 Kc as ordered. HF-20B, HF-20BX, HF-20TX: 4-22 Mc. Available to 2 Mc on special order. 5 latch-on tank coils for 4-22 Mc supplied in high frequency models. All other circuits continuously variable including output network.

RATED OUTPUT POWER: 540-1600 Kc, 20KW. 4-18 Mc, 20KW. 18-22 Mc, 16KW. HF-10TX may be operated in excess 20KW to 18 Mc, depending on mode of keying.

RF OUTPUT IMPEDANCE: BC-20B, 50 to 300 ohms as ordered. High frequency models, 300-800 ohms.

POWER REDUCTION: Low power tune-up control provided.

POWER INPUT: 0 modulation, 37KW. Average modulation, 43KW. 100% modulation (sine wave), 55KW. 230 volts, 3 phase, 50 or 60 cycles (as ordered). Other input voltages available on special order.

FREQUENCY RESPONSE: $\pm 1\frac{1}{2}$ db 50-10,000 cycles.

RATED DISTORTION: 4% or less 50-7500 cycles.

CAPABLE DISTORTION: 3% or less 50-7500 cycles.

NOISE: 55 db or better below 100% modulation.

RF STABILITY: 0.005% or better, all models.

RF VOLTAGE FOR MONITORS: BC-20B provides take-off for frequency and modulation monitors, where used.

KEYING: 400 WPM or less. Provision for FSK.

SIZE: 210" wide, 49" deep, 78" high. Door swing front and back, 40". Floor space external power and modulation units, 10'x2 $\frac{1}{2}$ '.

WEIGHT/CUBAGE: Packed, 23,000 lbs. Cubage 720.

TUBES: 6AG7 oscillator, 6AG7 first IPA, 6146 buffer doubler, two 4-250A RF drivers, four 3X2500F3 power amplifiers, two 6SJ7 audio amplifiers, two 807 amplifiers, two 845 driver amplifiers, four 3X3000A3 modulators, twelve 673 rectifiers, two 866/866A modulator bias rectifiers, two 8008 PA bias rectifiers and two 8008 low voltage rectifiers. For HF-20TX omit 807, 845 and 3X3000A3 tubes.

ORDERING INFORMATION

	Cat. No.
20KW medium wave broadcast transmitter with one set tubes, one crystal and oven	BC-20B
20KW short wave broadcast transmitter with one set tubes, less crystals	HF-20B
20KW short wave broadcast and telegraph transmitter with one set of tubes, less crystals	HF-20BX
20KW short wave telegraph transmitter only, with one set of tubes, less crystals	HF-20TX
Crystal and holder for high frequency models	JK03-H17
Crystal and oven for medium frequency models	JK57M
Spare 100% tube complement for BC-20B, HF-20B, HF-20BX	TK-139
Spare 100% tube complement for HF-20TX	TK-140

PRICES: Shown on pink supplemental sheet in back of this catalog.

NOTE 1: For description of crystals, listing of rhombic or other antennas, communications limiter/audio filter amplifier, monitors or transmitter audio control console—see Index for proper page.

NOTE 2: Be sure and state frequency or frequencies of operation, line voltage frequency and output coupling impedance, when ordering.

5/10KW BROADCAST TRANSMITTERS

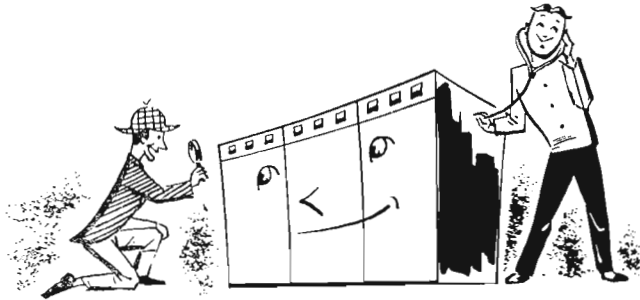

Gates leadership in the 5/10KW field is world-wide. — The first to offer a low cost tube complement, the first to offer better performance standards, the first to offer lower power consumption and, as always, the pace-setter in lower selling prices versus advanced designs. These very new 5 and 10KW transmitters continue to amplify Gates leadership in providing big husky equipments that are as reliable as their fine performance and as modest in selling price as truly fine equipment can be built.

Users of BC5/10 Series Transmitters

- | | | |
|-------------------------------|---------------------------------------|------------------------------------|
| WILD—Birmingham, Alabama | WVNH—Rochester, N. H. | CKVL—Verdun, Quebec, Canada |
| WOOF—Dothan, Alabama | WBUD—Trenton, New Jersey | CBI—Sydney, Nova Scotia, Canada |
| KCNA—Tucson, Arizona | WENE—Endicott, New York | CBV—Quebec, Quebec, Canada |
| KLCN—Blytheville, Arkansas | WWRL—New York City | CBO—Ottawa, Ontario, Canada |
| KXJK—Forrest City, Arkansas | WNYC—New York City | CKCH—Hull, Quebec, Canada |
| KXLR—North Little Rock, Ark. | WBBB—Burlington, N. Carolina | YSU—San Salvador, El Salvador |
| KPOL—Los Angeles, California | WIST—Charlotte, North Carolina | YSS—San Salvador, El Salvador |
| KOWL—Santa Monica, California | WTOB—Winston-Salem, N. C. | South African Broadcasting Co. |
| KAVR—Apple Valley, California | WEED—Rocky Mount, N. Carolina | XEDF—Nuevo Laredo, Mexico |
| KBIG—Avalon, California | WGBR—Goldsboro, N. Carolina | XETU—Tampico, Mexico |
| KPMC—Bakersfield, California | WNXT—Portsmouth, Ohio | ZQI—Kingston, Jamaica |
| KTLN—Denver, Colorado | KERG—Eugene, Oregon | CMCU—Havana, Cuba |
| KIMN—Denver, Colorado | WBSC—Bennettsville, S. Carolina | KLER—Lewiston, Idaho |
| WBOY—Tarpon Springs, Florida | WDKD—Kingstree, S. Carolina | WCOJ—Coatesville, Pennsylvania |
| WDVH—Gainesville, Florida | KUTA—Salt Lake City, Utah | WVNA—Tuscumbia, Alabama |
| WMGR—Bainbridge, Georgia | KOVO—Provo, Utah | WJAM—Marion, Alabama |
| WMTM—Moultrie, Georgia | KLO—Ogden, Utah | WBKH—Hattiesburg, Mississippi |
| WLET—Toccoa, Georgia | WRIS—Roanoke, Virginia | WLIK—Newport, Tennessee |
| KFXD—Nampa, Idaho | WFHG—Bristol, Virginia | KIUP—Durango, Colorado |
| KRLC—Lewiston, Idaho | WWOD—Lynchburg, Virginia | ELWA—Monrovia, Liberia |
| WTAD—Quincy, Illinois | WCHS—Charleston, West Virginia | XEPR—Poza Rica, Mexico |
| WLS—Chicago, Illinois | WJLS—Beckley, West Virginia | YNBH—Nicaragua |
| KSCJ—Sioux City, Iowa | WHIS—Bluefield, West Virginia | YVOB—San Cristobal, Venezuela |
| KGNO—Dodge City, Kansas | WBEL—Beloit, Wisconsin | Radio Pakistan |
| WWKO—Ashland, Kentucky | KPOW—Powell, Wyoming | Indonesian Broadcasting System |
| WTVB—Coldwater, Michigan | CFRA—Ottawa, Ontario, Canada | Manila Broadcasting Co. |
| WKMI—Kalamazoo, Michigan | CKOM—Saskatoon, Sask., Canada | La Voz de Cali—Colombia, S. A. |
| WXYZ—Detroit, Michigan | CJMS—Montreal, Quebec, Canada | Radiosal-Lima, Peru, S. A. |
| WKNK—Muskegon, Michigan | CJON—St. John's, Newfoundland, Canada | Radio Bucaramanga, Colombia, S. A. |
| WILS—Lansing, Michigan | CBN—St. John's, Newfoundland, Canada | Radio Bolivariana, Colombia, S. A. |
| KTOE—Mankato, Minnesota | CKBL—Poncheville, Quebec, Canada | Radio Pacifico, Colombia, S. A. |
| WCOW—South St. Paul, Minn. | | |
| KRES—St. Joseph, Missouri | | |
| KGCX—Sidney, Montana | | |



NOTE: Listing as of November 15, 1955. Omissions are entirely unintentional. Many listed above are multiple users such as South Africa, Radio Pakistan, Radio Indonesia, Radio San Salvador and others ranging up to 10 transmitters per owner. U. S. Government installations both in Europe and Far East not listed for Security reasons.

GATES

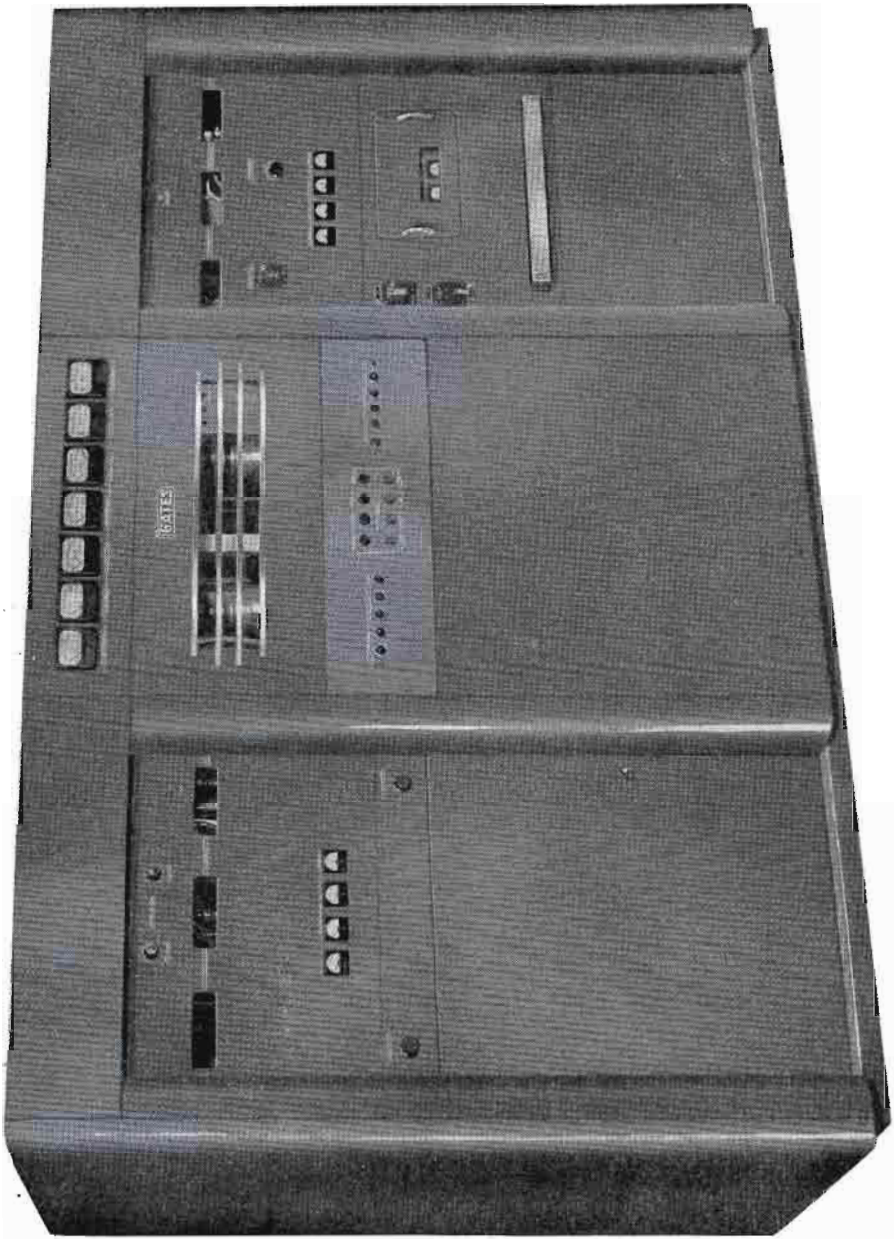

BC5/10B Broadcast Transmitter

Gates BC5/10 Transmitters Challenge Comparison

The new "Hi-Watter" seal on Gates transmitters means more watts per dollar investment. Compare features, design, circuitry, quality and engineering and you will find why the Gates name appears on more American broadcast transmitters. Gates transmitters are engineered to excellence in technical design and performance. But engineering is far more than this! — Gates "Hi-Watter" transmitters are engineered to eliminate waste motion in manufacture. — The result is lower cost and better quality. — Check just a few of these "Hi-Watter" features:

- (1) Full supervisory control and circuit protection including automatic carrier reset. 24 trouble-free relays provide transmitter-wide protection and control. _____ Compare!
- (2) Interchangeable tubes in power amplifier and modulator for lower tube operating cost. _____ Compare!
- (3) Complete dead front with all operating functions unhampered by door interlocks. _____ Compare!
- (4) Available in 2 styles: DELUXE, for minimum floor space, completely self-contained, and CUSTOM, with large external oil filled power modulation and reactor units. _____ Compare!
- (5) No variable condensers in final tank or loading sections. Use of large variable coils eliminates flash-overs. — Compare!
- (6) Complete relay system (feature 1 above) makes adaption to remote control simple and reliable. _____ Compare!
- (7) No inter-sectional cabling required to place in operation. The wiring is done for you and not by you. — Compare!
- (8) Complete forced air cooling. — The large squirrel cage blower not only cools the tubes but the entire transmitter. _____ Compare!
- (9) Performance standards that pace the industry in noise, distortion, response, stability, carrier shift and regulation. _____ Compare!
- (10) Low operating cost, low power consumption, long tube life and husky components combine for emphatically lower operating cost. _____ Compare!
- (11) Rugged design — big transmitter construction means reliability and greater assurance of safe arrival at your doorstep. _____ Compare!
- (12) Walk-in construction. For maintenance and servicing, the technical man was remembered. _____ Compare!
- (13) Low tube cost. Only eight standard approved types all available worldwide. _____ Compare!
- (14) Gates workmanship. There is confidence in a product well built. Gates workers have accepted the challenge of leadership they have created. _____ Compare!

(Continued next page)

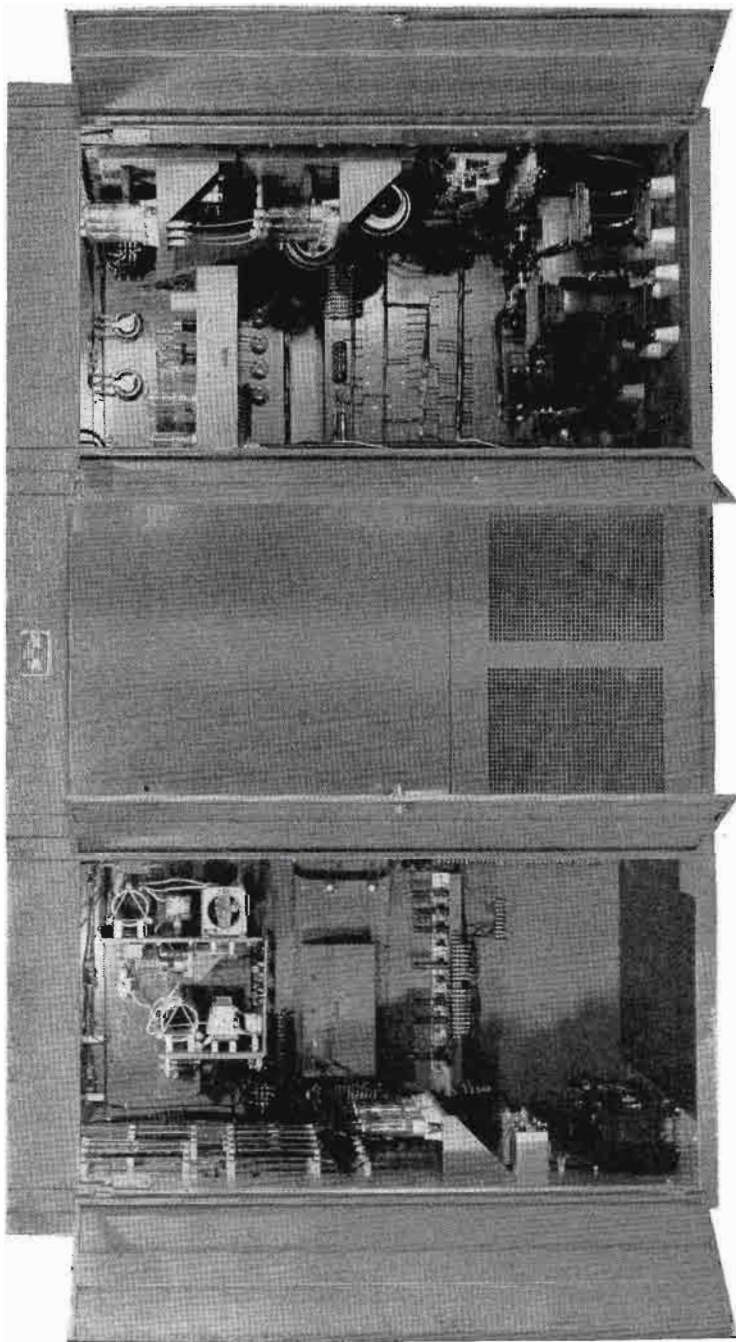

Rear view BC-5E/BC-10E Transmitters
(DeLuxe Model)

5000/10,000 Watt Broadcast Transmitters

The rear view, on opposite page, will illustrate how competent engineering has developed a big roomy transmitter that utilizes little more floor space, yet provides that ease of maintenance demanded in the busy day of the technical staff. This deluxe model is self-contained with all power and modulation components within the cabinet. Even more space for "walk in to service" is provided in the custom model where external components are employed for power and modulation transformers.

Gates engineers recognized that top performance standards are an obvious requirement and nothing is left undone in this respect. Through the life of any broadcast transmitter top performance must be compatible with ease in servicing or maintenance. Gates roomy design, to Gates engineers, meant reaching any part in seconds, and demanded that every nook and corner could be easily cleaned. They went so far as to light the inside of the transmitter when the back doors open.

Facility-wise, these new 5 and 10KW transmitters have, in our opinion, no equal. There are not just ample meters, circuit protection, cooling and component size, but a generous abundance. Anyway the comparison is made, the quality excellence is self-evident.

(continued next page)

No transmitter made today in the 5/10KW field can claim such a complete relay/control circuit complement. Part of this system is illustrated below where 21 relays and circuit breakers are reached simply by opening a front door.

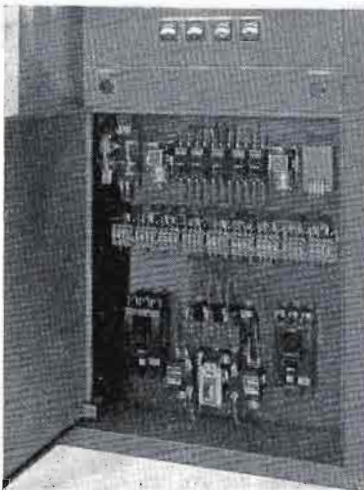

All incoming air both to power tubes and the entire transmitter is 100% filtered. Filter may be removed for cleaning while transmitter is in operation, an important extra the technical staff will especially appreciate.

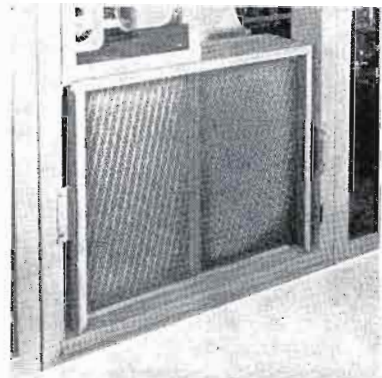

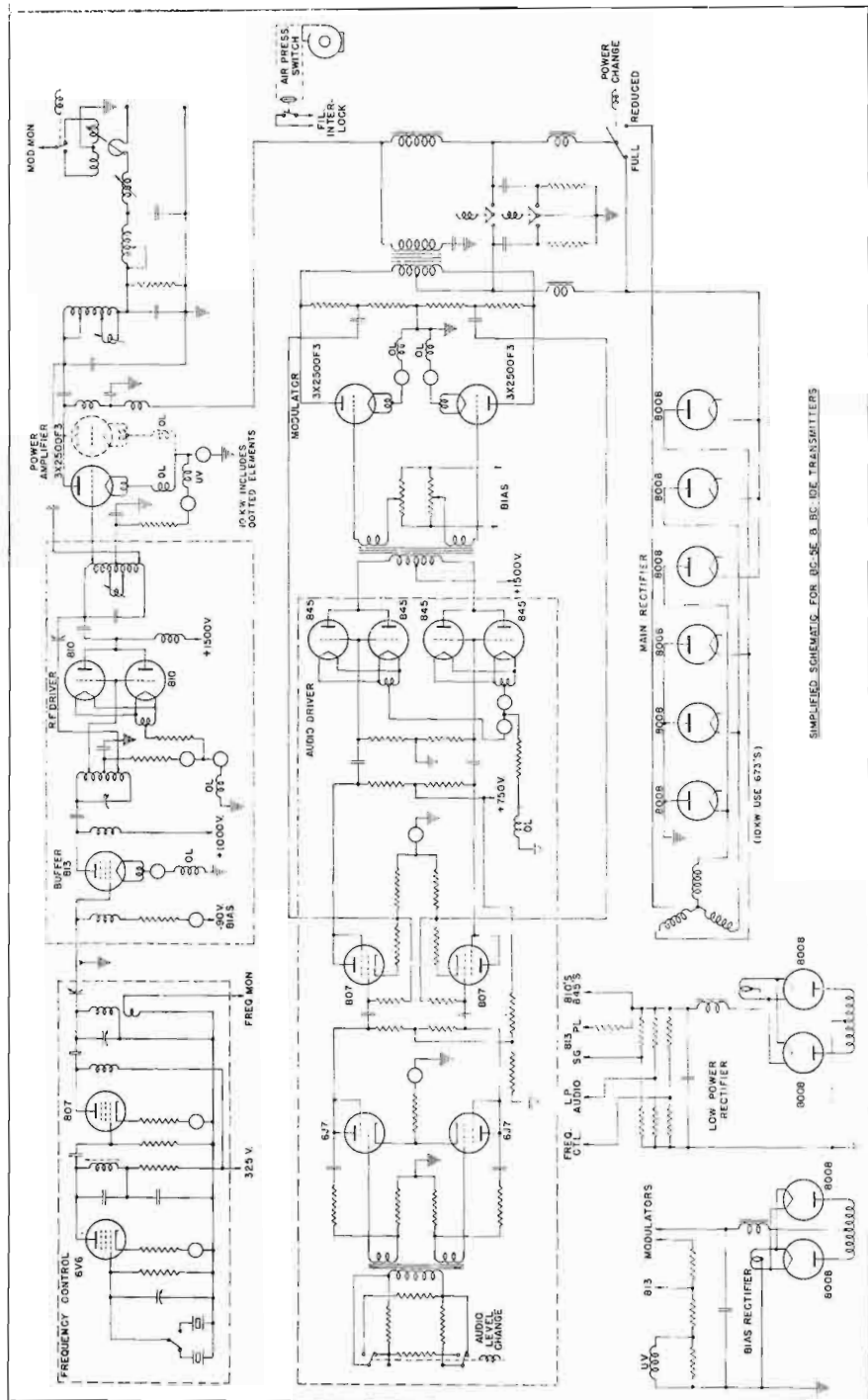

Functional Diagram BC-5/BC-10E Transmitters

BC-5E/BC-10E BROADCAST TRANSMITTERS

CONSTRUCTION of the three cubicles or cabins is from cold rolled furniture grade steel, resistance welded and finished in hand rubbed 3-tone gloss gray. Absence of ripple or crackle finish assures ease of retaining the new appearance and cleanliness. — Back doors are split to conserve valuable floor space. All cubicles are wired complete and bolt together quickly for installation. Cubicles are wired together by jumpers supplied which connect to side-by-side terminal boards. — Transmitter may be installed with greater assurance of **FIRST ON** performance because of complete factory testing and by reason of no wiring left for the purchaser to do.

TRANSFORMERS in the **DELUXE** model are self-contained and require no external components of any kind. In the **CUSTOM** model the transformers are of the large oil filled type and mount externally (see next page). In either the deluxe or custom models, transformers are for world-wide service. — All Gates transmitters are made for 50/60 cycle operation. This means a bonus or conservatism for 60 cycle users as 50 cycle transformers must be larger in capacity. It also means no waiting for those in 50 cycle areas.

CONTROL FUNCTIONS in big transmitters are vitally important. No transmitter in the 5KW field can boast of the complete relay protection afforded. There are 8 overload and underload relays, 7 circuit breakers and a full complement of time delay, air interlock, condenser discharge, power change, primary contractor, supervisory control and door interlock relays. — Automatic carrier reset is standard equipment wherein the carrier attempts to re-establish itself 3 times before turning off.

COOLING is a feature. The entire cabinet is cooled, as well as the power tubes. A double cushion 800 CFM blower sends a blast of air to the power tubes and, by deflecting baffles, into the cabinet itself. A separate small blower places air at the base of each main mercury rectifier tube. Air flow protection is by means of a diaphragm type air pressure switch and not a damper or flipper.

METERING is by means of 17 properly located meters. Note that meters have been grouped functionally correct or — the meter is near the point of adjustment involving the meter being used.

(Continued next page)

Interior view of main rectifier. Note blower that pipes air stream to base of each mercury vapor rectifier tube. To left of blower is condenser discharge switch which shorts out high voltage filter capacitors when any interlocked door opens.

This partial picture of the center power amplifier section certainly tells the **BIG DESIGN** story. Importance of component size, installation and ease of accessibility is never underestimated.

Another power amplifier view. Note the terminal boards at the bottom. These line up with similar terminal boards on the adjacent cubicle. After jumpering together (jumpers supplied), the transmitter is complete—no cabling during installation is required.

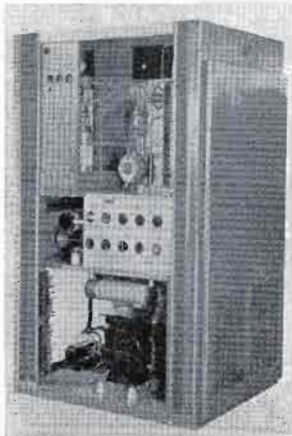
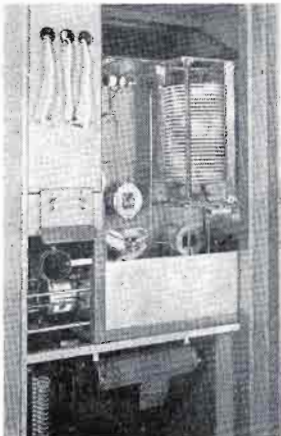
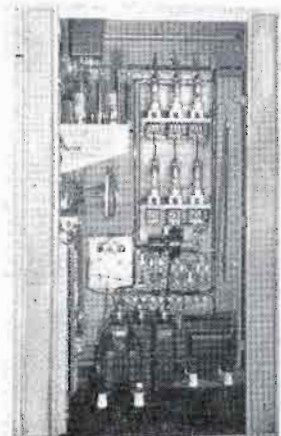

General Detail BC-5E/BC-10E Transmitters

CIRCUIT: Five radio frequency stages are excited by dual temperature controlled crystals. All controls are on the front, including crystal accessibility. The radio frequency output circuit does not employ variable condensers, and tuning is by means of variable inductors controlled from the front panel by geared veeeder counter controls. — A full 3-section tank circuit is employed with dual inductor Tee network output coupling for assured low spurious radiation. The four-stage audio circuit includes an abundance of extra capacity. Note the four 845 driver tubes, purposely provided to retain low distortion with aging tubes. Overall feedback is used as an adjunct for better performance and not as a corrective measure for an undersized or an omitted component. — The six tube, three phase, full wave main rectifier assures lower power supply ripple and better regulation. Two other major power supplies divide the power load for greater reliability.

TUBES are important in initial cost and the tube complement cost is low. Even more important is tube life—and the selection of tubes combined with the efficient cooling system makes the tube complement of the BC-5E the lowest of any five kilowatt transmitter. — It cannot be emphasized too strongly that tube life depends on the applied engineering both to circuit and cooling design. Not a single tube in the transmitter even approaches maximum rating

and power tubes are provided with much more air for cooling than required by the tube manufacturer.

DEAD FRONT is an important design feature. It is a design with the technical man in mind. Inability to tune or meter read a circuit because it is behind an interlocked door is exasperating, difficult and sometimes hazardous. Every circuit may be tuned and meter read with full voltage applied.

TEN KILOWATTS: Increase in power to 10KW, if required, can be accomplished by adding one power tube and changing power transformer, modulation transformer, reactor and two filter chokes. The entire design of the 5KW model is to 10KW standards.

THE PRICE TAG: The value of leadership is greater sales. The result of more transmitters manufactured is lower production cost. Making broadcast transmitters is a major part of Gates business—not a small percentage sideline. — It is logical that our major effort, both engineeringly and in manufacturing methods, is to produce more for lower cost to the user. — In part, our very existence depends upon it. — Though better, Gates transmitters are usually lower in initial cost, and always in maintenance cost, and bring a higher resale price if the broadcaster ever changes his mode of operation.

(Continued next page)

In the custom model the large oil filled power and modulation transformers plus modulation reactor are external. These may be mounted behind the transmitter, in the basement, or out of doors in a cage or on a platform. The deluxe model has transformers self-contained. Gates is the only manufacturer offering this choice.

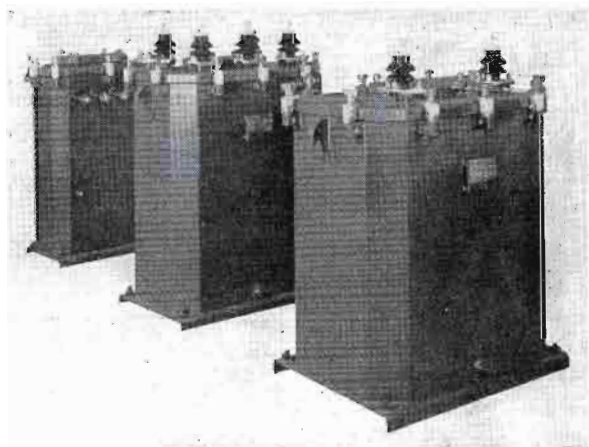

Blower is not only of such size to supply abundance of air to the power tubes but is baffled to the entire transmitter. Inside of the BC-5E/BC-10E is a virtual whirlpool of air.

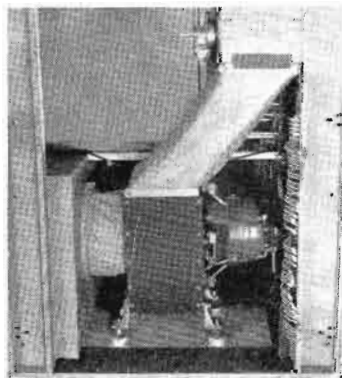

BC-5E/BC-10E SPECIFICATIONS

	BC-5E	BC-10E
POWER OUTPUT:	5000 watts	10,000 watts
CAPABLE POWER OUTPUT:	5600 watts	10,700 watts
POWER REDUCTION:	to 1000 watts	to 5, 2½ or 1KW as ordered
AUDIO RESPONSE:	±1½ db 30-12,000 cps ±2½ db 30-15,000 cps	±1½ db 30-10,000 cps ±2½ db 30-10,000 cps
RATED OVERALL DISTORTION AT 95% MODULATION:	50-10,000 cps, 3%	50-10,000 cps, 3%
CAPABLE OVERALL DISTORTION AT 95% MODULATION:	50-10,000 cps, 2½% or less	50-10,000 cps, 2½% or less
AUDIO INPUT ±2 DB:	150/600 ohms at +10 dbm	150/600 ohms at +12 dbm
NOISE:	60 db or better below 100% modulation	60 db or better below 100% modulation
MODULATION:	High level Class B	High level Class B
FREQUENCY STABILITY:	±5 cycles	±5 cycles
FREQUENCY RANGE:	540-1620 Kc as ordered	540-1620 Kc as ordered
RF OUTPUT IMPEDANCE:	40-250 ohms as ordered	40-250 ohms as ordered
RF VOLTAGE FOR MONITORS:	Sufficient for all types	Sufficient for all types
POWER INPUT VOLTAGE:	230 volts, 3-wire, 3-phase —208 where required	230 volts, 3-wire, 3-phase —208 where required
POWER CONSUMPTION:		
100% modulation:	18KW	29KW
Average program:	13.4KW	22½KW
Idling:	12KW	20KW
LINE FREQUENCY:	50/60 cycles	50/60 cycles
CARRIER SHIFT:	Less than 3%	Less than 3%
SIZE:	125" wide, 78" high, 48" deep (add 7'x2½' floor space for custom model with ex- ternal components)	125" wide, 78" high, 48" deep (add 7'x2½' floor space for custom model with ex- ternal components)
RF CIRCUIT:	5 stages single ended	5 stages single ended
OUTPUT CIRCUIT:	Full Tee network (3 sections with tank)	Full Tee network (3 sections with tank)
FINAL TUNING:	Variable coils throughout	Variable coils throughout

TUBES BC-5E: (10) 8008, (4) 845, (3) 3X2500F3, (3) 807, (2) 6J7, (2) 810,
(1) 813, (1) 6U6.

TUBES BC-10E: (6) 673, (4) 8008, (4) 845, (4) 3X2500F3, (3) 807, (2) 6J7,
(2) 810, (1) 813, (1) 6U6.

WEIGHT AND CUBAGE, BC-5E (deluxe): Net 4100, Gross 5400, Cubage 290.

WEIGHT AND CUBAGE, BC-10E (deluxe): Net 4500, Gross 5900, Cubage 310.

WEIGHT AND CUBAGE, BC-5E (cus:om): Net 5200, Gross 6700, Cubage 315.

WEIGHT AND CUBAGE, BC-10E (cus:om): Net 6500, Gross 8200, Cubage 331.

NOTE: For air or van shipment and where boxing is not required, use net weights +2%.
It is important to note that all common carriers require boxing. Only private carriers
and furniture vans do not require boxing.

BC-5E/BC-10E ORDERING INFORMATION

Cat. No.

Model BC-5E (deluxe) 5000 watt transmitter completely self-contained with one set of tubes, one crystal and oven	M5135
Model BC-5E (custom) 5000 watt transmitter with external oil filled power components, with one set tubes, one crystal and oven	M5135A
Model BC-10E (deluxe) 10,000 watt transmitter completely self-contained, with one set of tubes, one crystal and oven	M5284
Model BC-10E (custom) 10,000 watt transmitter with external oil filled power components, with one set tubes, one crystal and oven	M5284A
Spare crystal and oven	JK57M
100% spare tube complement, BC-5E	TK-204
100% spare tube complement, BC-10E	M3825

PRICES: See pink supplemental price list in the back of this catalog.

NOTE: Be sure to state carrier frequency and RF output impedance when ordering.
—For directional phasors, see Index.

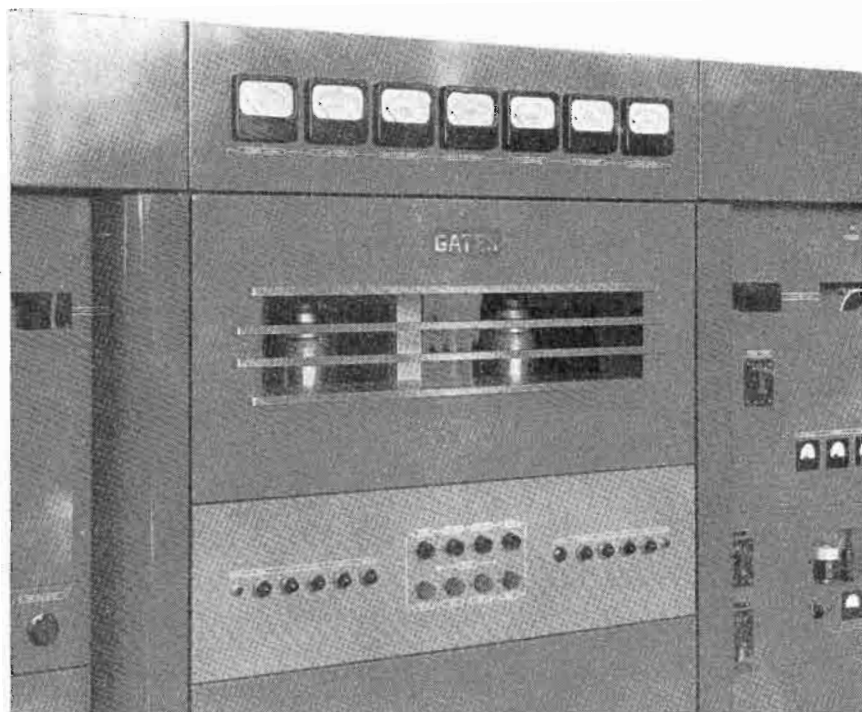



3 Outstanding Broadcast Transmitters!

On the following pages are described, we believe, three of the most outstanding radio broadcast transmitters ever manufactured. Powers of 1000, 500 and 250 watts are in one standard model. All, being made nearly identical, are produced at the same time. By greater quantity production, purchasing position is improved and construction cost is reduced. The result is the "Hi-Watter" symbol of more watts per dollar investment.

Gates is the only manufacturer where producing broadcast equipment is the major portion of its business. Gates engineers continually study not only the best technical methods but improved manufacturing techniques to produce better equipment for less cost. The lowest selling price of any product is based on value received. Gates never designs or sells on the basis of price. Instead, the pace-setting modest selling prices are the result of "manufacturing engineering".

Slogans or phrases are not enough, however. Here are transmitters that can be moved around in power. A 250 watt model becomes a 500 or 1000 watt model or vice versa. All frequency 540-1600 Kc operation has advantages of wide latitudes in tune-up, Conelrad and if reselling, readiness on any frequency. Twin-drive audio and center line metering are outstanding. Best of all, instead of the bare necessities to make a transmitter, these Gates transmitters are component big and facility complete in every department.

BC-1J "Hi-Watter" 1000 Watt Transmitter



Leader in all departments, the Gates "Hi-Watter" BC-1J one kilowatt broadcast transmitter has from the beginning been the standard of comparison. Added to new high performance standards are many exclusive features found only in Gates. Designed entirely new, the modest selling price is the result of "manufacturing engineering" where better quality is developed through modern production methods and not through reduced design to meet price.

(more next page)

Gates "Hi-Watter" 1KW Broadcast Transmitter

Compare

|

Feature for feature, either component, construction or performance . . . this "Hi-Watter" one kilowatt excels.

|

Compare

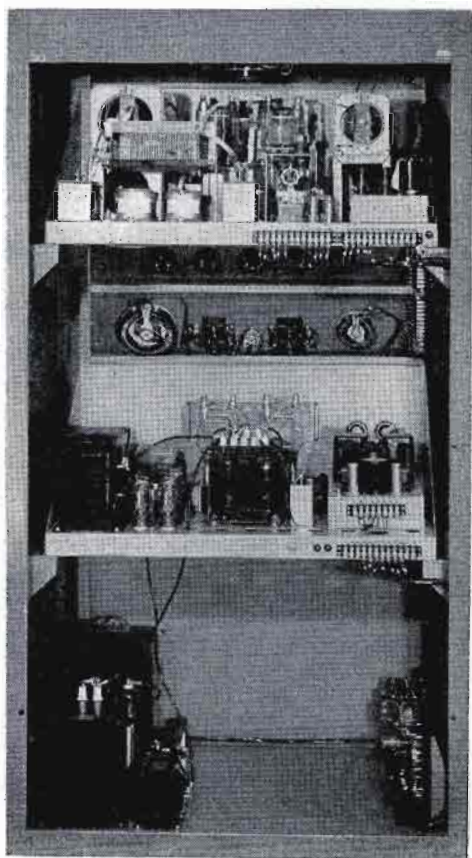

Circuit breakers are no substitute for a complete protective relay complement in the BC-1J "Hi-Watter". Photo below shows: (1) filament start relay, (2) plate start relay, (3) PA overload relay, (4) modulator overload relay, (5) under drive relay, and (6) time delay relay. — This is complete protection. This is the relay system that makes adaptation to remote control simple and easy.

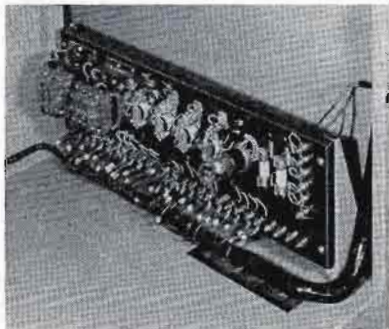

- The only transmitter that tunes the entire broadcast band 540-1600 Kc, as supplied.
- The only transmitter that tunes to Conelrad without buying extra parts.
- Twin-drive audio system is only found in Gates.
- Center line metering is a functional exclusive that means Gates has kept the operator in mind.
- Trouble-free triodes in both PA and modulator stages.
- Full-fledge Tee network output assures low harmonic radiation.
- No variable condensers in any part of the PA or line coupling eliminates flash-overs.
- Seven relays for full protection and easy adaptation to remote control. No circuit breakers.
- Large 4" meters throughout.
- Easy to service, reach every part in seconds. No stacking or complicated cabling.
- A real looker. Attractive to the engineering eye. Attractive to the visiting prospect.

(more next page)

GATES

"Hi-Watter"---More Watts Per Dollar Investment

THE GATES BC-1J, 1000 watt transmitter is built into a rugged and massive appearing cabinet constructed of stretcher level furniture steel, resistance welded and finished in two-tone gloss gray. It is hand rubbed to create a transmitter commercially attractive and, by the absence of ripple finish, the new appearance is easy to retain. The sloping, eye level meters and control panels add greatly to the ease of operation, serviceability and appearance. The back door is of the slip-on type. This makes it possible to place the transmitter near the back wall, conserving floor space ordinarily occupied by a hinged door. Size is 78" high, 42" wide and 30" deep.

THE TOP radio frequency deck and center audio frequency-intermediate power decks are essentially independent operating units. This adds to operator ease in servicing. The oscillator and twin-drive audio units are sub-chassis, also quickly removable. Relay panel is mounted in the base of the cabinet with full access for servicing where required.

FOUR RADIO FREQUENCY STAGES assure stability, low carrier shift and an abundance of driving power. Crystal oscillator is untuned. Inserting the crystal is all that is required. Individual trimmer capacitors for each crystal along with air gap adjustment allows exact frequency adjustment. The incorporation of all necessary frequency determining components allows op-

eration on any frequency from 540-1600 Kc as supplied. Changing to Conelrad requires only the necessary crystal for the Conelrad frequency. Large edgewise coils reduce losses and add to efficiency, creating lower power consumption. Final tank and Tee network section are continuously variable, making unnecessary hazardous variable air capacitors in power circuits. Fixed neutralization eliminates the troublesome front panel control.

BOTH RADIO FREQUENCY power amplifier and modulators are the same tube type. This means interchangeability and the need for less spare tubes. Low tube cost has been measured by both moderate initial cost and long tube life. All tubes employed are of popular types obtainable universally without unusual effort.

CIRCUIT PROTECTION as well as circuit control has always been a feature in Gates transmitters and is no exception in this model. Instead of high speed circuit breakers that do not lend themselves to remote control, both filament and plate contactors, pushbutton controlled, make start and stop functions positive. Where Conelrad is employed, the ability to disrupt and reset the carrier instantaneously can only be accomplished with dual contactors. Vitally important, and again especially so for remote control, is the under drive relay which turns off the high voltage where RF drive fails. This feature alone
(Continued next page)

Engineers will appreciate the heavy construction of this radio frequency section. Note large edgewise coils, big mica capacitors and roomy, easy to service design. The RF section and modulator section are complete, self-contained operating units which adds to ease in maintenance checking.

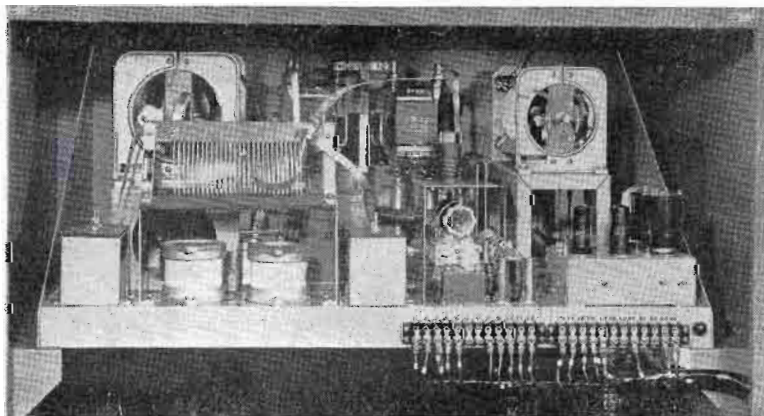

BC-1J 1000 WATT BROADCAST TRANSMITTER

could save a costly modulation transformer or other expensive part. Overload relays are provided for both RF power amplifier and modulator. A vacuum type time delay relay is standard equipment. — The relay panel has terminals provided for connection of necessary remote control functions, minimizing alterations when adding remote control.

POWER SUPPLIES all operate from 230 volts, single phase, 50/60 cycles. These consist of: (1) dual 8008 main rectifiers, (2) 5R4GY bias supply, (3) 5R4GY low voltage supply, and (4) dual 5R4GY intermediate voltage supply. The elimination of all power type voltage dropping resistors develops both savings in power consumption and lower heat content in the cabinet, plus greater reliability.

GATES has approached cooling in a new and very sound way. The lower front panel of the transmitter is actually a perforated plate 34" x 24½" in size. Taking the cool center of the

room air at floor level, this is pulled up through the transmitter by a quiet operating suction fan in the top of the cabinet. Result is much lower inner-cabinet temperatures, highly desirable in every case but particularly so if transmitter is unattended by reason of remote control.

THE ENGINEER will be very interested in the complete Tee network output coupling circuit. With the emphasis on lower spurious radiation, this Tee network, with the wide range of capacitors provided by reason of the complete 540-1600 Kc frequency coverage, offers the engineer a wide range of self-contained components to meet many abnormal situations. With tank and output coupling coils of heavy edgewise design and continuously variable from the front panel, the tune-up at highest efficiency is assured.

PHASING EQUIPMENT in matching cabinet design is available to meet consulting engineer's specifications.

Center line metering is emphasized by the complement of large 4" meters. The convenience in tuning and logging cannot be underestimated. Optional line meter is shown at the top.

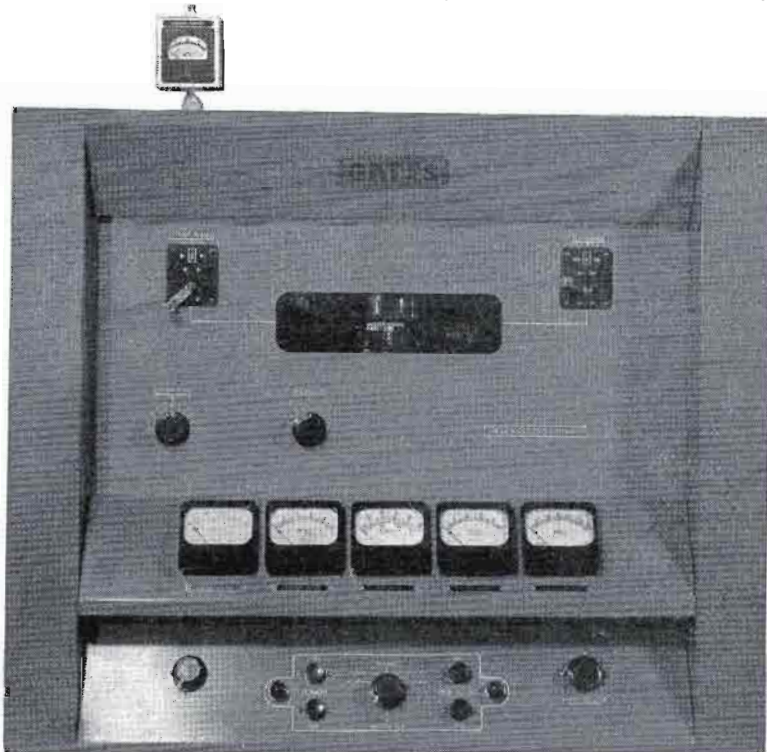

BC-1J SPECIFICATIONS

AUDIO INPUT IMPEDANCE: 150/250/600 ohms.

AUDIO INPUT LEVEL (100% modulation):
+10 dbm \pm 2 dbm.

AUDIO RESPONSE: 50-7500 cycles, \pm 1 db.
30-12,000 cycles, \pm 1 1/2 db.

RATED AUDIO DISTORTION (95% modulation, 50-10,000 cps.): 3%.

CAPABLE AUDIO DISTORTION (95% modulation, 50-10,000 cps.): 2% or better.

NOISE (unweighted) below 100% modulation: 60 db or better.

RADIO FREQUENCY RANGE: 540-1600 Kc. Supplied with necessary frequency determining components to cover entire band and not just a single operating frequency.

MODULATION: High level Class B.

FREQUENCY STABILITY: \pm 5 cycles.

TYPE OF OUTPUT: Single ended.

OUTPUT IMPEDANCE: To match 50-73 ohms at all frequencies, 540-1600 Kc. Coupling unit available for other impedances. (See next page).

FREQUENCY MONITOR: From first IPA at 70 ohms to excite all approved models.

MODULATION MONITOR: Scramble wound coil in direct output (70 ohms) to excite all approved models.

CARRIER SHIFT: 3% or less 0-100% modulation.

RATED OUTPUT: 1000 watts (capable of 1100 watts where required).

INPUT POWER: 230 volts, two wire, 50/60 cycles, single phase. 3200-4500 watts as per modulation percentage. Available for 208 volts when ordered.

CRYSTAL HEATER INPUT: 230 volts, 50/60 cycles.

SIZE: 78" high, 42" wide, 30" deep.
Floor space 8.7 sq. ft.

WEIGHT (unpacked): 816 lbs.

WEIGHT (packed): 1066 lbs.

TUBE COMPLEMENT: Four 833A, 1622 or 5881, 5R4GY; two 800B, 6SN7, 6AG7, 6146; one 6AQ5, 0B2.

NUMBER OF RF STAGES: Four.

NUMBER OF AF STAGES: Twin-drive input; three overall stages.

COOLING: Large perforated front grill and air exit suction fan in ceiling of transmitter.

(Continued next page)

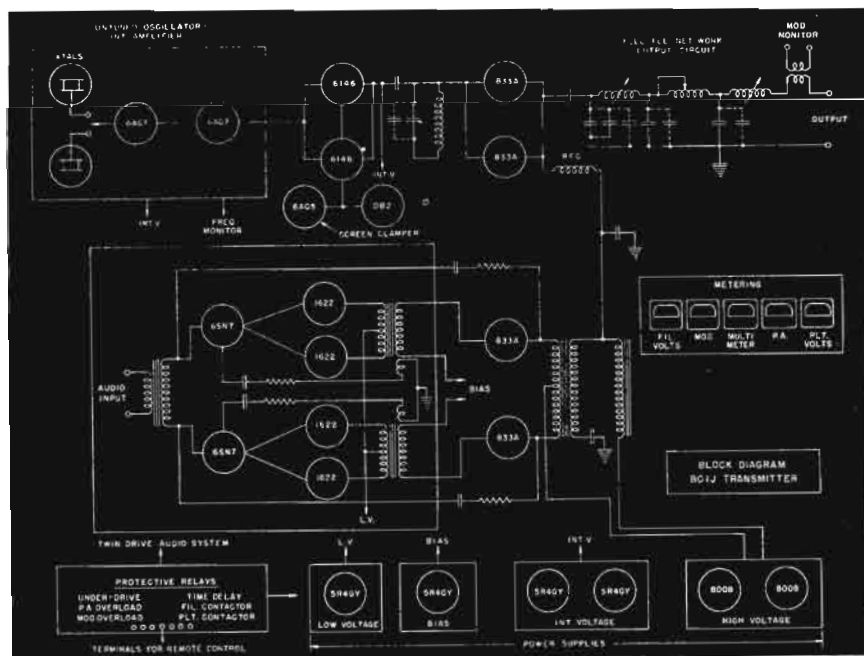

BC-1J Accessories --- Ordering Information



Antenna Couplers

(series or shunt fed)

This well constructed antenna coupling unit, available for series or shunt fed antennas, is designed to match either a 50 or 73 ohm input impedance to a wide variety of output conditions, matching nearly all conceivable vertical type antennas. Consists of edgewise coil of tapped type and fixed capacitors, the combination of which will produce Tee or L network arrangements. Whether used several hundred feet from the transmitter through transmission line or for direct coupling, this antenna coupler unit is recommended for best performance of the overall system. Size: 22 1/8" high, 10" wide, 9" deep. M-5177 radio frequency ammeter listed below may be attached to top of feed-thru bowl if antenna meter desired.

Antenna coupler for series fed antenna M-5178
 Antenna coupler for shunt fed antenna M-5179

NOTE: Please state frequency and transmission line impedance when ordering as well as provide any available data on antenna if known.

Power Reduction Kit

Where power output of the BC-1J, 1000 watt transmitter is to be reduced to 500 watts night, this kit is quickly installed in the transmitter and operates from a single toggle switch on the front panel. Consists of a relay, dropping power resistors and audio pad, all mounted and wired on an insulated plate which mounts with four screws to the side of the cabinet.

Power reduction kit
 for 1000/500
 watts M-3768A

RF Ammeter Unit

Consists of a 0-6 RF ammeter in rectangular case and may be attached to the output feed-thru insulator of either the BC-1J transmitter to read line current or the antenna couplers listed above to read antenna current. As meter is mounted in aluminum rectangular case, it may be located elsewhere if desired. Other meter ranges available as required.

RF Ammeter Unit in case,
 0-6 amperes M-5177

RF Ammeter Unit in case,
 0-3 amperes M-5177A

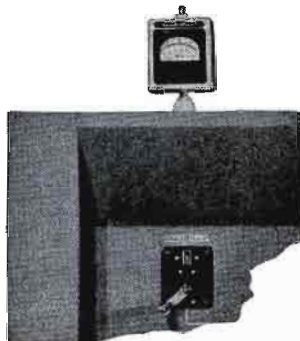

Ordering Information

	<u>Cat. No.</u>
1KW transmitter complete with tubes, crystal and oven, for all frequency coverage, 540-1600 Kc, and to match either 50/73 ohm transmission line	BC-1J
Power Reduction Kit for 1000/500 watts	M-3768A
RF Ammeter in case, 0-6 amperes	M-5177
RF Ammeter in case, 0-3 amperes	M-5177A
Antenna coupling unit, series fed, as described above	M-5178
Antenna coupling unit, shunt fed, as described above	M-5179
100% spare tube complement for BC-1J transmitter	TK-206
FCC required spare tube complement for BC-1J transmitter	TK-208
Extra crystal and oven	JK57M

NOTE: Prices will be found on the pink price sheet in the back of this catalog. Be sure to state frequency of operation when ordering.



500 Watt Broadcast Transmitter, Model BC-500K

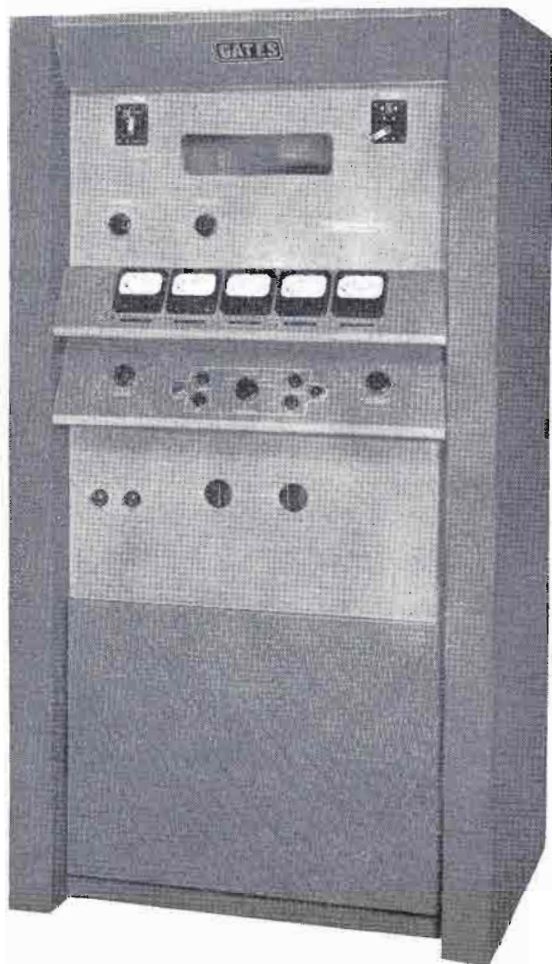

Like the BC-1J "Hi-Watter" one kilowatt transmitter, this 500 watt Model BC-500K is one of three nearly identical transmitters, modified slightly for proper power rating but all manufactured on the same production line.

This not only creates greater production quantities and emphasizes the true meaning of the "Hi-Watter" slogan, "More Watts Per Dollar Investment" but allows a quick alteration in the power either up to 1000 watts or down to 250 watts. This feature is highly valuable, particularly in the case of power increase and at no penalty in cost.

In this newest Gates 500 watt model the broadcaster in the large part actually has a 1000 watt transmitter. The basic difference is in one PA tube, power, modulation and reactor transformers. They are so similar that the change from 500 to 1000 watts power could be made in 30 minutes.

(Continued next page)

The "Hi-Watter" 500 Provides 1KW Design

BC-500K Offers You:

- Basic 1KW design in a 500 watt model.
- Conversion later to 1KW at no cost penalty and in 30 minutes' time.
- Inbuilt 540-1600 Kc. components. Tunes to Conelrad without purchase of additional components.
- Complete relay system, no circuit breakers, easy attachment of remote control.
- Twin-drive audio.
- Center line metering.
- Pace-setting performance standards.

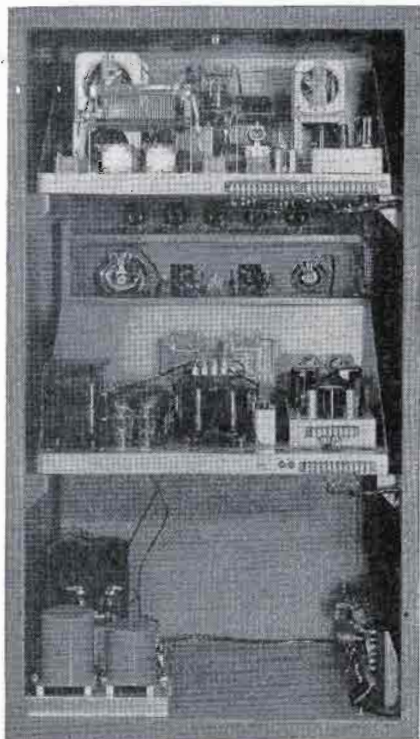

Perhaps the best way to describe this new Gates "Hi-Watter" 500 is to say, "Read the description of the 1000 watt BC-1J on the preceding pages." Actually the BC-500K is a modified one kilowatt. Only few components are changed to meet 500 watt requirements. Even the various chassis are drilled for the 1KW components for later power increase. If this never happens, the BC-500K owner has the largest and most conservative 500 watt transmitter ever built and at no excess in selling price.

The 500 watt model has one 833A RF power amplifier. Modulation transformer, reactor, power transformer, main filter chokes and PA fixed mica capacitors are one size smaller in the 500 watt model, compared to the BC-1J, 1KW equipment. Otherwise it is the same. Same relay complement, same modulator throughout including the big 833A Class B modulators that will last and last, same large edgewise coils with Tee network output for low harmonic radiation, and the same wonderful performance specifications that have made Gates the leader in AM transmitter sales for over a decade.

Best of all are the many exclusives. Gates only supplies complete 540-1600 Kc tuning, meaning Conelrad at no extra cost and at many frequencies spare mica capacitors in the PA and output coupling stages. Twin-drive audio provides more audio drive at new performance standards with lower cost tubes. Center line metering is a functional natural while the full complement of seven relays means honest to goodness protection and the positive way of handling remote control. — Here indeed is broadcasting's finest 500 watt transmitter.

(Continued next page)

Specifications --- Ordering Data BC-500K

SPECIFICATIONS

AUDIO INPUT IMPEDANCE: 150/250/600 ohms.
AUDIO INPUT LEVEL (100% modulation): +7 dbm ± 2 dbm.
AUDIO RESPONSE: 50-7500 cycles, ± 1 db.
 30-10,000 cycles, $\pm 1\frac{1}{2}$ db.
RATED AUDIO DISTORTION (95% mod., 50-12,000 cps.): 3%.
CAPABLE AUDIO DISTORTION (95% mod., 50-12,000 cps.): 2% or better.
NOISE (unweighted) below 100% modulation: 60 db or better.
RADIO FREQUENCY RANGE: 540-1600 Kc. Supplied with necessary frequency determining components to cover entire band and not just a single operating frequency.
MODULATION: High level Class B.
FREQUENCY STABILITY: ± 5 cycles.
TYPE OF OUTPUT: Single ended.
OUTPUT IMPEDANCE: To match 50-73 ohms at all frequencies 540-1600 Kc. Coupling unit available for other impedances. (See page 29).

FREQUENCY MONITOR: From first IPA at 70 ohms to excite all approved models.
MODULATION MONITOR: Scramble wound coil in direct output (70 ohms) to excite all approved models.
CARRIER SHIFT: 2% or less 0-100% modulation.
RATED OUTPUT: 500 watts (capable of 550 watts where required).
INPUT POWER: 230 volts, two wire, 50/60 cycles, single phase. 2450-3250 watts as per modulation percentage. Available for 208 volts where ordered.
CRYSTAL HEATER INPUT: 230 volts, 50/60 cycles.
SIZE: 78" high, 42" wide, 30" deep.
 Floor space 8.7 sq. ft.
WEIGHT: Unpacked, 750 lbs. Packed, 998 lbs.
TUBE COMPLEMENT: Three 833A, 1622 or 5881, 5R4GY; two 800B, 6SN7, 6AG7, 6146; one 6AQ5, 6B2.
NUMBER OF RF STAGES: Four.
NUMBER OF AF STAGES: Twin-drive input; three over-all stages.
COOLING: Large perforated front grill and air exit suction fan in ceiling of transmitter.

ORDERING INFORMATION

500 watt transmitter complete with one set of tubes, crystal and oven, for 50/73 ohms output, 540-1600 Kc operation and 230 volts, 50/60 cycles	Cat. No. BC-500K
100% spare tube complement for BC-500K	TK-214
FCC required spare tube complement for BC-500K	TK-208
Extra crystal and oven	JK57M
Conversion parts including components and tubes to increase power to 1000 watts	M-5218

ANTENNA COUPLER: Models M-5178 or M-5179, listed on Page 29, are recommended. See Index (Antenna Couplers) for many other available models.

RF AMMETER: Where required, use M-5177 or M-5177A, listed on Page 29.

NOTE: Prices are shown on pink supplemental price list in back of this catalog. Be sure to state frequency of operation when ordering.

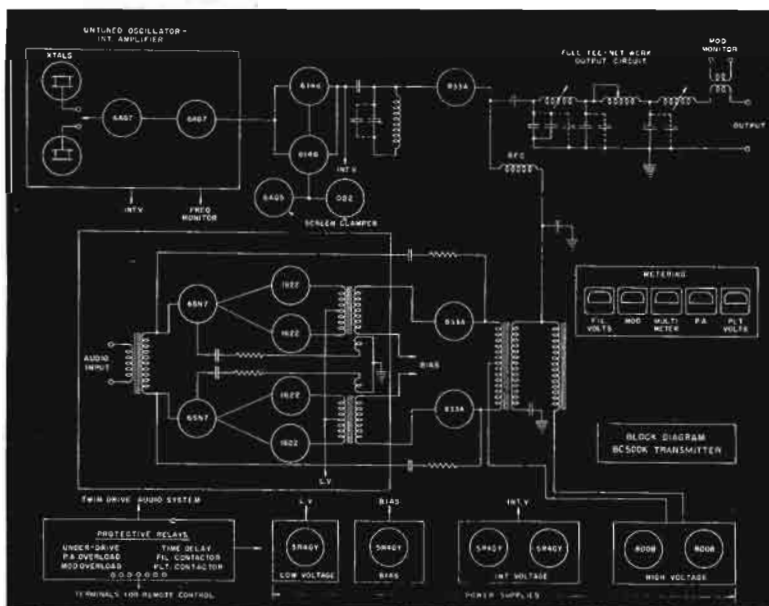

BC-250L BROADCAST TRANSMITTER

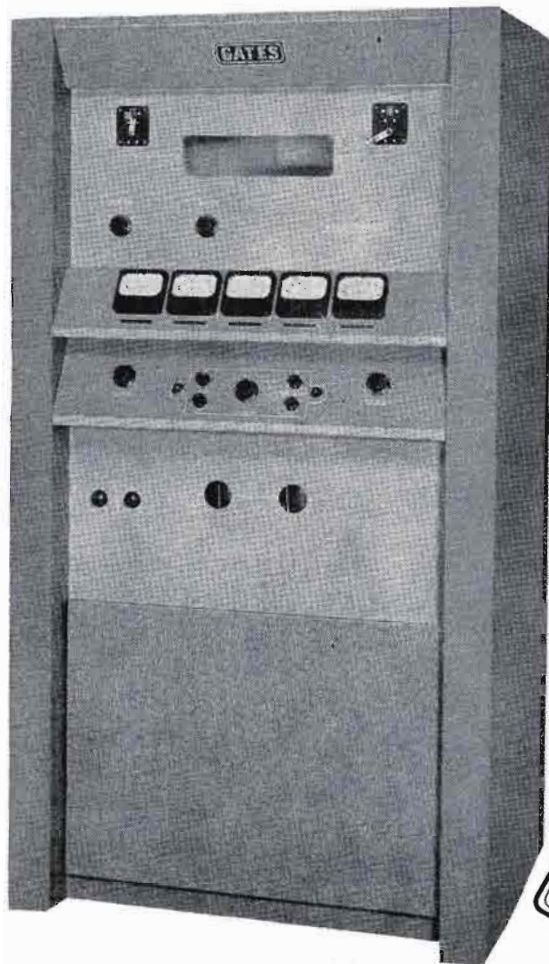

250 watts now — 500/1000 watts later. For the broadcaster that has an eye on future higher power. Conversion to higher power is simple, quick and no more costly than buying higher power in the first place.

Three models of "Hi-Watter" transmitters, all nearly identical, are built on one production line. These are 250, 500 and 1000 watt broadcast plus a 1KW short wave model. This means lower production cost passed on in savings to the customer.

This 250 watt model is actually a modified 1KW transmitter to meet 250 watt requirements. Changing to 500 or 1000 watts takes less than an hour. No broadcast transmitter offers so much value as the new Gates BC-250L for 250 watts.

(More next page)

GATES

250 Watts Now --- Higher Power Later

540-1600 Kc As Supplied To You

WHEN YOU UNBOX your BC-250L transmitter, you will find that it will tune to any frequency between 540 Kc and 1600 Kc. — Though you operate on only a single frequency, the value of this feature is great. You have inbuilt Conelrad already for you and at full performance standards. Regardless of frequency, the change to Conelrad can be made in seconds, often only by retuning from the front, while at the extreme only changing a jumper or two, as all frequency determining components are in-built from 540 to 1600 Kc. — Greater in importance is uniformity. To build an all-frequency transmitter, careful attention must be given to LC ratios and circuit design which means, regardless of your carrier frequency, top efficiency and performance. There is no chance for incorrect size of frequency determining components because all are supplied—your guarantee of top efficiency and top performance.

THE GATES BC-250L, 250 watt transmitter is built into a rugged and massive appearing cabinet constructed of stretcher level furniture steel, resistance welded and finished in two-tone gloss gray. It is hand rubbed to create

a transmitter commercially attractive and, by the absence of crackle or ripple finish, the new appearance is easy to retain. The sloping, eye level meters and control panels add greatly to the ease of operation, serviceability and appearance. The back door is of the slip-on type. This makes it possible to place the transmitter near the back wall, conserving floor space ordinarily occupied by a hinged door. Size is 78" high, 42" wide and 30" deep.

THE TOP radio frequency deck and center audio frequency-intermediate power decks are essentially independent operating units. This adds to operator ease in servicing. The oscillator and twin-drive audio units are sub-chassis, also quickly removable. Relay panel is mounted in the base of the cabinet with full access for servicing where required.

FOUR RADIO FREQUENCY STAGES assure stability, low carrier shift and an abundance of driving power. Crystal oscillator is untuned. Inserting the crystal is all that is required. Individual trimmer capacitors for each crystal along with air gap adjustment allows exact frequency adjustment. The incorporation of all necessary frequency determining components allows operation

(Continued next page)

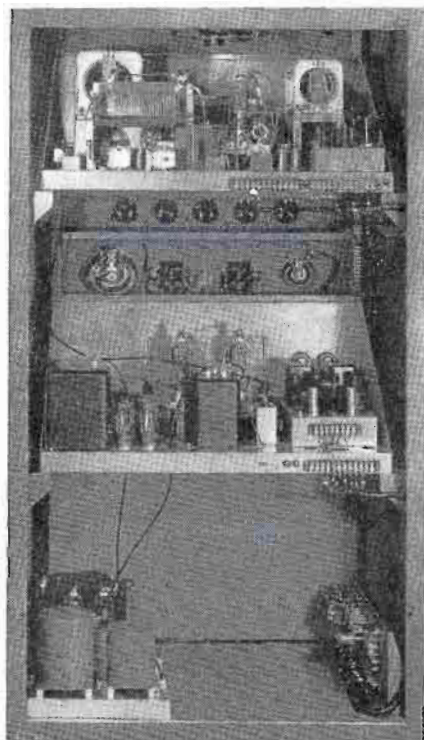

- ← Big edgewise coils in tank and Tee network.
- ← Complete 540-1600 Kc coverage. Conelrad at no extra cost plus wider tuning range.
- ← Push-button, relay controlled filament and plate start. No circuit breakers.
- ← Twin-drive audio.
- ← 3 low voltage power supplies.
- ← Roomy design for ease in maintenance. No stacking.
- ← Reliable triodes in PA and modulator stages.
- ← Complete relay system for protection and ease in attaching remote control.

"HI-WATTER" 250 WATT TRANSMITTER

on any frequency from 540-1600 Kc as supplied. Changing to Conelrad requires only the necessary crystal for the Conelrad frequency. Large edgewise coils reduce losses and add to efficiency, creating lower power consumption. Final tank and Tee network section are continuously variable, making unnecessary hazardous variable air capacitors in power circuits. Fixed neutralization eliminates the troublesome front panel control.

BOTH radio frequency power amplifier and modulators are the same tube type. This means interchangeability and the need for less spare tubes. Low tube cost has been measured by both moderate initial cost and long tube life. All tubes employed are of popular types obtainable universally without unusual effort.

CIRCUIT PROTECTION as well as circuit control has always been a feature in Gates transmitters and is no exception in this model. Instead of high speed circuit breakers that do not lend themselves to remote control, both filament and plate contactors, push-button controlled, make start and stop functions positive. Where Conelrad is employed, the ability to disrupt and reset the carrier instantaneously can only be accomplished with dual contactors. Vitaly important, and again especially so for remote control, is under drive relay which turns off the high voltage where RF drive fails. This feature alone could save a costly modulation transformer or other expensive part. Overload relays are provided for both RF power amplifier and modulator. A vacuum type time delay relay is standard equipment.—The relay panel has terminals provided for connection of necessary remote control functions, minimizing alterations when adding remote control.

POWER SUPPLIES all operate from 230 volts, single phase, 50/60 cycles. These consist of: (1) dual 8008 main rectifiers, (2) 5R4GY bias supply, (3) 5R4GY low voltage supply, and

(4) dual 5R4GY intermediate voltage supply. The elimination of all power type voltage dropping resistors develops both savings in power consumption and lower heat content in the cabinet, plus greater reliability.

GATES has approached cooling in a new and very sound way. The lower front panel of the transmitter is actually a perforated plate 34" x 24½" in size. Taking the cool center of the room air at floor level, this is pulled up through the transmitter by a quiet operating suction fan in the top of the cabinet. Result is much lower inner-cabinet temperatures, highly desirable in every case but particularly so if the transmitter is unattended by reason of remote control.

FOR POWER INCREASE, the engineer will be particularly interested in the expansion capabilities of this transmitter from 250 watts to either 500 watts or 1000 watts. The change involves actually the exchange of only a few components. Chassis and cabinet are drilled for these components for such time as they are needed. Basic changes include replacement of power transformer, modulation transformer, reactor, two filter choke coils,

three meters, mica filter capacitors and tube sockets for the power amplifiers and modulators. In making this modification, it is doubtful that the technical man will even require the use of a soldering iron. It is emphasized that the BC-250L transmitter is actually a 1000 watt equipment modified to operate at 250 watt power. This means that such items as inductors, intermediate power supplies, the complete audio system other than modulators, wiring and insulation are all of 1000 watt design.

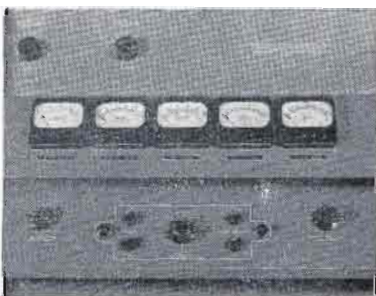

Center line metering puts tuning and visual functions together. It is functionally correct.

WITH EMPHASIS on lower spurious radiation, the Tee network output coupling system with the wide range of capacitors and inductors, provided by reason of the complete 540-1600 Kc frequency coverage will be very interesting to the experienced engineer in coping with low harmonic radiation.

STILL MORE INBUILT RELIABILITY

All "Hi-Watter" 250, 500 and 1000 watt models are designed for both 50 and 60 cycles. For 60 cycle users this spells larger transformers to cope with the more rugged demands of 50 cycles. For those in 50 cycle areas it means no waiting as all "Hi-Watter" models are for 50/60 cycle operation.

BC-250L Specifications --- Ordering Data

SPECIFICATIONS

AUDIO INPUT IMPEDANCE: 150/250/600 ohms.
AUDIO INPUT LEVEL (100% modulation): ± 4 dbm ± 2 dbm.
AUDIO RESPONSE: 50-7500 cycles, ± 1 db.
 30-12,000 cycles, $\pm 1\frac{1}{2}$ db.
RATED AUDIO DISTORTION (95% mod., 50-10,000 cps.): 3%.
CAPABLE AUDIO DISTORTION (95% mod., 50-10,000 cps.): 2% or better.
NOISE (unweighted) below 100% modulation: 60 db or better.
RADIO FREQUENCY RANGE: 540-1600 Kc. Supplied with necessary frequency determining components to cover entire band and not just a single operating frequency.
MODULATION: High level Class B.
FREQUENCY STABILITY: ± 5 cycles.
TYPE OF OUTPUT: Single ended.
OUTPUT IMPEDANCE: To match 50-73 ohms at all frequencies 540-1600 Kc. Coupling unit available for other impedances.

FREQUENCY MONITOR: From first IPA at 70 ohms to excite all approved models.
MODULATION MONITOR: Scramble wound coil in direct output (70 ohms) to excite all approved models.
CARRIER SHIFT: 2% or less 0-100% modulation.
RATED OUTPUT: 250 watts (capable of 280 watts where required).
INPUT POWER: 230 volts, two wire, 50/60 cycles, single phase. 1000-1400 watts as per modulation percentage. Available for 208 volts where ordered.
CRYSTAL HEATER INPUT (primary): 230 volts, 50/60 cycles.
SIZE: 78" high, 42" wide, 30" deep.
 Floor space 8.7 sq. ft.
WEIGHT: Unpacked, 710 lbs. Packed, 938 lbs.
TUBE COMPLEMENT: Four 810, 1622 or 5881, 5R4GY; two 800B, 6SN7, 6AG7, 6146; one 6AQ5, 0B2.
NUMBER OF RF STAGES: Four.
NUMBER OF AF STAGES: Twin-drive input; three over-all stages.
COOLING: Large perforated front grill and air exit suction fan in ceiling of transmitter.

ORDERING INFORMATION

Cat. No.

250 watt transmitter complete with tubes, crystal and oven for 540-1600 Kc coverage, 230 volts, 50/60 cycles	BC-250L
100% spare tube complement for BC-250L	TK-207
FCC required spare tube complement for BC-250L	TK-218
Extra crystal and oven	JK57M
Conversion parts including components and tubes to increase to 500 watts power	M-5216
Conversion parts including components and tubes to increase to 1000 watts power	M-5217

ANTENNA COUPLERS: Models M-5278 and M-5279, listed on Page 29, are recommended. For many other available couplers, see (Antenna Couplers — Index).

RF AMMETER: Where required, use M-5177A, listed on Page 29.

NOTE: Prices shown on pink supplemental price list in back of this catalog. Be sure and state operating frequency when ordering.

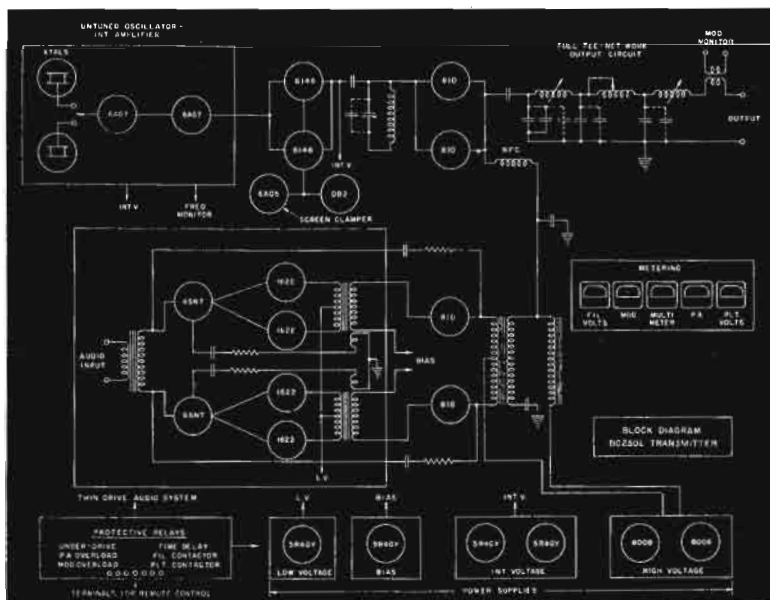

BC-1F "International" 1KW Broadcast Transmitter

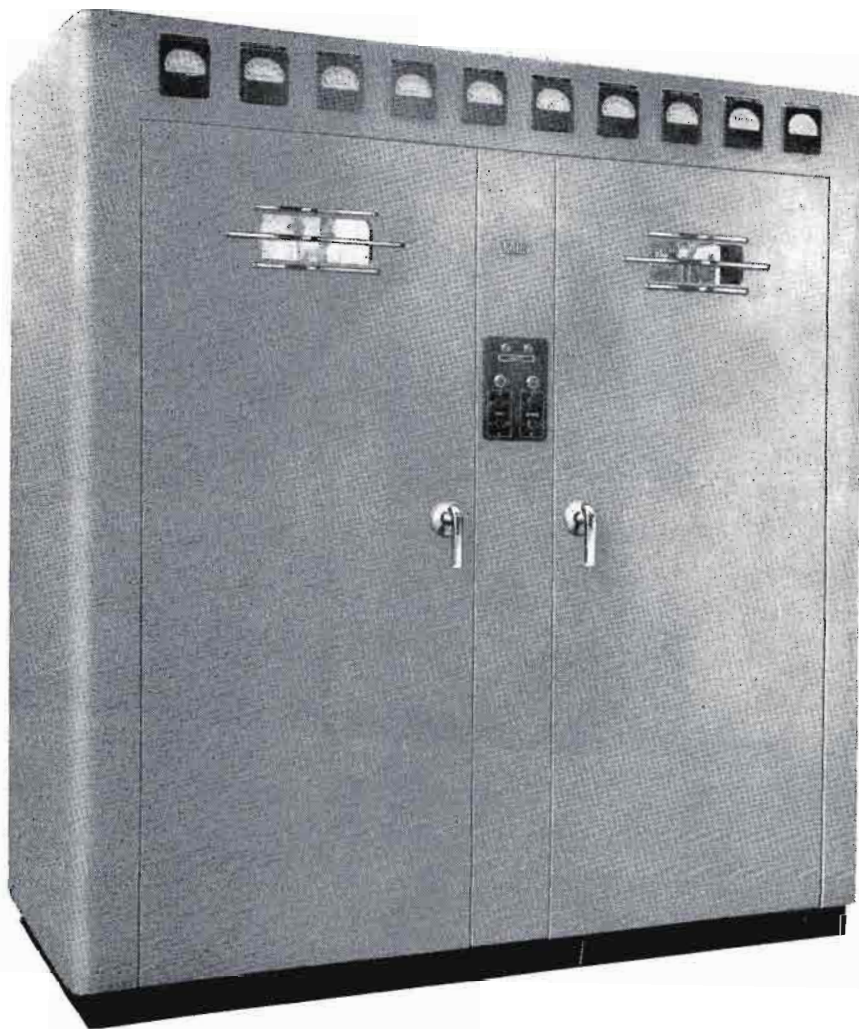

Certainly the BC-1F "International" has been properly named as it is the most used one thousand watt broadcast transmitter in the world today. — Without question, the largest, most rugged and best built 1KW transmitter available anywhere. In this transmitter every conceivable facility, refinement and inbuilt quality will be found. Nothing has been spared! For those who demand luxury equipment, the Gates BC-1F "International" stands out alone as the very finest.

(Continued next page)

GATES

GATES BC-1F "INTERNATIONAL" 1KW

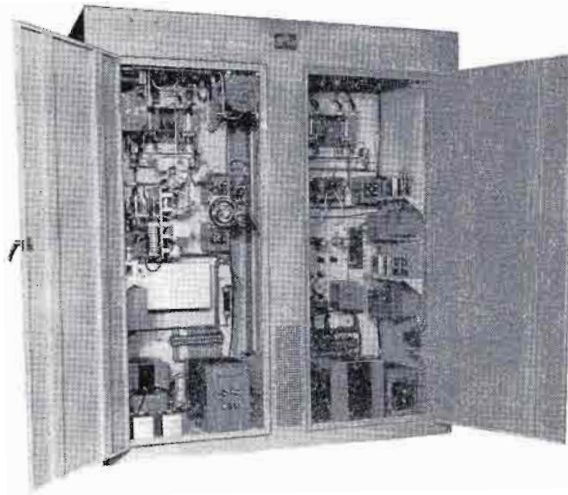

Large in size means large component size, ease of servicing and all of the extra components that are expected in class equipment. Standing 78" high, 72" wide and 33" deep, the BC-1F "International" is a massive equipment. Every part is as close as the outstretched hand. Double front and rear doors seal tight when closed for semi-pressure air cooling. Ten 4" meters and 3 smaller meters read every circuit including an "hours consumed" meter. Four power supplies divide the load with 575A rectifiers, usually found only in 5000 or 10,000 watt transmitters, providing ultra conservatism in the main power supply. Big edgewound coils are used throughout and final tank/output coupling employs variable coils for tuning in place of vulnerable variable air condensers.

Air cooling is important. Air circulation to every part, large or small, means long trouble-free service. Inside the BC-1F "International" is likened to an air tunnel. Air blasts by power resistors, rheostats, transformers and tubes. Incoming air is filtered. Squirrel cage blower is over-sized to point that there is a complete air change every 15 seconds.

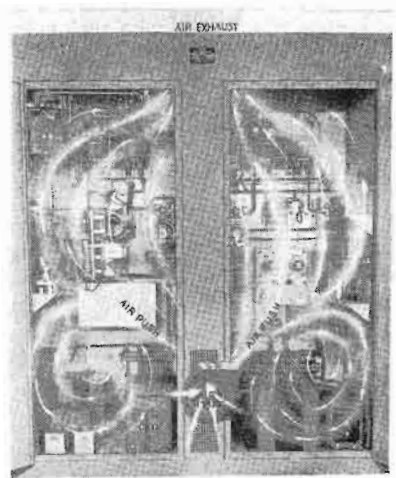

BC-1F Transmitter Specifications

CARRIER FREQUENCY RANGE: 540 to 1600 Kc as ordered.

FREQUENCY STABILITY: ± 5 cycles.

POWER OUTPUT: 1000 watts or 500 watts as ordered and as rated by FCC.

CAPABLE POWER OUTPUT: 1200 watts.

RF HARMONICS: Below .05 %.

AC POWER INPUT: 230 volts (115/115 volts) single phase. Plate transformer tapped for 210, 220, 230 volts. Filament and plate voltage controlled by rheostats on front of cabinet.

POWER CONSUMPTION: 1000 watts output; average program level, 4400 watts; 100 % modulation, 4900 watts; 500 watts output; average program level, 3550 watts; 100 % modulation, 4400 watts.

NOTE: For good regulation provide at least 6KW service.

TUBES: One each, 6V6, 807, 813; two each, 6J7, 6J5, 845, 575A, 866/866A; three each, 5U4G; four each, 833A.

OUTPUT CIRCUIT: Pi-network tank and Tee network output coupling provide low harmonic radiation. Continuously variable coil tuning eliminates variable air condensers and possibility of arc-over.

OUTPUT IMPEDANCE: 40 to 300 ohms as ordered (unbalanced).

RADIO FREQUENCY: 4 stages self-neutralized except final stage. PA (2) 833A single ended.

CRYSTALS: Provision for 2 in two temperature controlled ovens.

AUDIO: 4 stages with 6 db overall feedback. Modulators high level Class B 833A.

FREQUENCY RESPONSE: ± 1 db 30-10,000 cycles.

DISTORTION: 2½ % or less 50 to 10,000 cycles at 95 % modulation.

NOISE: 60 db or better below 100 % modulation.

AUDIO INPUT: 500/600 ohms at 0 dbm ± 2 db.

CARRIER SHIFT: 2 % or less from 0 to 100 % modulation.

SIZE AND COLOR: 78" high, 72" wide, 33" deep. Supplied medium gray trimmed in black and chrome.

WEIGHT: Domestic packed, 3100 lbs. Export packed, 3450 lbs. Cubage with tubes, 255.

DOOR SWING: Front, 25". Rear, 28".

METERING: Ten 4" meters across top including dual modulator meters and "Hours Consumed" meter. Three smaller meters for oscillator, intermediate amplifier and 813 grid drive.

COOLING: Forced filtered air.

RELAYS: Filament start relay, plate start relay, time delay relay, bias voltage relay and four overload relays, one each for RF driver amplifier, RF power amplifier, audio driver amplifier and modulators. Also master relay. All front of cabinet access.

MONITOR PROVISIONS: Direct terminal connections. Gates MO-2890 frequency monitor connects to output of first intermediate amplifier. Gates MO-2639 modulation monitor connects inductively to tank coil. Pickup loop is part of equipment. Any make of monitor may be used.

AUDIO MONITORING: Direct loudspeaker connections (500 ohms) to filament return of RF power amplifier gives off the air monitoring.



Rugged attractiveness of the BC-1F "International" is typified in this modern installation. Phasor and accessory cabinet are to right of transmitter. Photo courtesy of WKCT, Bowling Green, Kentucky.

BC-1F Ordering Data --- GY-1000 Radio Station



GY-1000 Radio Station:

Includes BC-1F "International" transmitter and MO-3066 complete accessory cabinet as illustrated on Page 61. Styling joiner panel is provided as illustrated above. The GY-1000 comprises the complete transmitter building installation meeting all Government regulations. Includes frequency and modulation monitors, limiting audio amplifier, input switching panel, high level output for monitoring loudspeaker, coaxial cables between cabinets. Ready to attach to audio input and RF output line.

ORDERING INFORMATION

	<u>Cat. No.</u>
BC-1F "International" Radio Broadcast Transmitter with one set of tubes, one crystal and oven, for 1000 watts output	M-3250
BC-1F "International" Radio Broadcast Transmitter with one set of tubes, one crystal and oven, for 1000/500 watts output	M-3410
GY-1000 Complete Radio Station with one set of tubes, crystal and oven, includes joiner panel and 12" monitoring loudspeaker	GY-1000
Spare crystal and oven	JK57M
100% spare tube complement	M-3379

PRICES: See pink supplemental price list in the back of this catalog.

NOTE: When ordering be sure to state carrier frequency and RF output impedance desired.

GATES

Those Using Gates BC-1F 1000 Watt Transmitter

- WRAG—Carrallton, Alabama
 WROS—Scottsboro, Alabama
 WRMA—Montgomery, Alabama
 WCRB—Birmingham, Alabama
 WWWB—Jasper, Alabama
- KTYL—Mesa, Arizona
 KDJI—Holbrook, Arizona
- KHBM—Monticello, Arkansas
 KWCB—Searcy, Arkansas
 KDAS—Malvern, Arkansas
 KPLN—Camden, Arkansas
 KPOC—Pacahontas, Arkansas
 KBLO—Hot Springs, Arkansas
 KRCH—Hot Springs, Arkansas
 KBHS—Hot Springs, Arkansas
 KVSA—McGehee, Arkansas
- City Police Dept., Los Angeles, Calif.
 KCNO—Alturas, California
 KCAL—Redlands, California
 KCHV—Coachella, California
 KBAB—El Cajon, California
- KGMC—Englewood, Colorado
 KGLN—Glenwood Springs, Colo.
- WPCT—Putnam, Connecticut
- WKSJ—Milford, Delaware
 WSUX—Seaford, Delaware
- WKXY—Sarasota, Florida
 WJVB—Jacksonville Beach, Florida
 WKWF—Key West, Florida
 WEAT—Lakeworth, Florida
 WEBY—Milton, Florida
 WFTW—Fort Walton, Florida
 WABR—Winter Park, Florida
- WCEH—Hawkinsville, Georgia
 WIMO—Winder, Georgia
 WJAT—Swainsboro, Georgia
 WTRP—LaGrange, Georgia
 WBRO—Waynesboro, Georgia
 WJAZ—Albany, Georgia
 WRCD—Dalton, Georgia
 WCLS—Columbus, Georgia
 WMLT—Dublin, Georgia
 WKLE—Washington, Georgia
 WCLB—Camilla, Georgia
- WGEM—Quincy, Illinois
 WKRS—Waukegan, Illinois
 WTIM—Taylorville, Illinois
 WCMY—Ottawa, Illinois
 WEIC—Charleston, Illinois
 WZD—Decatur, Illinois
 WITY—Danville, Illinois
 WOHW—Clinton, Illinois
 WIBV—Belleville, Illinois
- WRAY—Princeton, Indiana
 WARU—Peru, Indiana
- KOKX—Keokuk, Iowa
 KSMN—Mason City, Iowa
 KLEM—LeMars, Iowa
- KMAN—Manhattan, Kansas
 WMOR—Morehead, Kentucky
 WKCT—Bowling Green, Kentucky
 WTCW—Whitesburg, Kentucky
 WCTT—Corbin, Kentucky
 WFUL—Fulton, Kentucky
 WAIN—Columbia, Kentucky
 WBLN—Lebanon, Kentucky
 WRUS—Russellville, Kentucky
 WKOA—Hopkinsville, Kentucky
 WWKY—Winchester, Kentucky
 WBRT—Bardstown, Kentucky
 WCBL—Benton, Kentucky
 WHBN—Harrodsburg, Kentucky
 WHLN—Harlan, Kentucky
- WBOX—New Orleans, Louisiana
 WLCS—Baton Rouge, Louisiana
 KDBS—Alexandria, Louisiana
- WHXY—Bogalusa, Louisiana
 KJOE—Shreveport, Louisiana
 KB5F—Springhill, Louisiana
 KTBS—Thibodaux, Louisiana
- WRUM—Rumford, Maine
- WESM—Pocomoke City, Maryland
 WTR—Westminster, Maryland
 WPGC—Morningside, Maryland
 WAYE—Dundalk, Maryland
- WPEP—Taunton, Massachusetts
- WATC—Gaylord, Michigan
 WCEN—Mt. Pleasant, Michigan
 WBRN—Big Rapids, Michigan
 WEXL—Royal Oak, Michigan
- KDLM—Detroit Lakes, Minnesota
 KDUZ—Hutchinson, Minnesota
 KLIZ—Brainerd, Minnesota
- WDEB—Gulfport, Mississippi
 WJPR—Greenville, Mississippi
 WBLE—Batesville, Mississippi
 WLSM—Louisville, Mississippi
 WACR—Columbus, Mississippi
 WBKH—Hattiesburg, Mississippi
 WMAG—Forest, Mississippi
 WKDL—Clarksdale, Mississippi
- KMMO—Marshall, Missouri
 KCRV—Caruthersville, Missouri
 KWOC—Poplar Bluff, Missouri
 KWPM—West Plains, Missouri
 KSIS—Sedalia, Missouri
 KTCB—Malden, Missouri
 KWRT—Boonville, Missouri
 KLR5—Mountain Grove, Missouri
 KATZ—St. Louis, Missouri
- KRGI—Grand Island, Nebraska
 KBRL—McCook, Nebraska
- KPBM—Carlsbad, New Mexico
 KXVP—Artesia, New Mexico
 KOAT—Albuquerque, New Mexico
 KHOB—Hobbs, New Mexico
- WALK—Patchogue, New York
 WGSJ—Huntington, New York
 WLEA—Hornell, New York
 WBCA—Corning, New York
 WPAC—Pachogue, New York
- WMPM—Smithfield, N. C.
 WFBG—Fuquay Springs, N. C.
 WEYE—Sanford, N. C.
 WIAM—Williamston, N. C.
 WBBO—Forest City, N. C.
 WLAS—Jacksonville, N. C.
 WTAB—Tabor City, N. C.
 WWIT—Canton, N. C.
 WNOS—High Point, N. C.
 WAGR—Lumberton, N. C.
 WGOI—Goldsboro, N. C.
 WCDJ—Edenton, N. C.
- KILO—Grand Forks, N. D.
 WOHO—Toledo, Ohio
- KWHP—Cushing, Oklahoma
 KGWA—Enid, Oklahoma
 KNED—McAlester, Oklahoma
 KWCO—Chickasha, Oklahoma
 KOLS—Pryor, Oklahoma
- KGAL—Lebanon, Oregon
 KRWC—Forest Grove, Oregon
- WCPA—Clearfield, Pennsylvania
 WKAP—Allentown, Pennsylvania
 WLYC—Williamsport, Pennsylvania
 WPAZ—Pottstown, Pennsylvania
 WKVA—Lewistown, Pennsylvania
 WPCB—Red Lion, Pennsylvania
 WPEL—Montrose, Pennsylvania
 WHUN—Huntingdon, Pennsylvania
 WPAW—Pawtucket, Rhode Island
- WAKN—Aiden, S. C.
 WORD—Spartanburg, S. C.
 WMSC—Columbia, S. C.
 WLCC—Lancaster, S. C.
 WAGS—Bishopville, S. C.
 WFIG—Sumter, S. C.
 WOIC—Columbia, S. C.
 WGSW—Greenwood, S. C.
 WALD—Walterboro, S. C.
 WCKI—Greer, S. C.
- WOKE—Oak Ridge, Tennessee
 WLIL—Lenoir City, Tennessee
 WNAH—Nashville, Tennessee
 WKSJ—Pulaski, Tennessee
 WAGG—Franklin, Tennessee
 WLK—Newport, Tennessee
 WKBL—Covington, Tennessee
 WDKN—Dickson, Tennessee
 WDEH—Sweetwater, Tennessee
 WHLP—Centerville, Tennessee
 WAEW—Crossville, Tennessee
 WRGS—Rogersville, Tennessee
- KZIP—Amarillo, Texas
 KOSY—Texarkana, Texas
 KGKO—Dallas, Texas
 KBOP—Pleasanton, Texas
 KTRM—Beaumont, Texas
 KVSP—Lubbock, Texas
 KDAV—Lubbock, Texas
 KTXJ—Jasper, Texas
 KSPC—Sinton, Texas
 KPSP—San Angelo, Texas
- KSOP—Salt Lake City, Utah
 WDEV—Waterbury, Vermont
 WNIX—Springfield, Vermont
- WRIC—Richlands, Virginia
 WYVE—Wytheville, Virginia
 WARL—Arlington, Virginia
 WLSJ—Big Stone Gap, Virginia
 WNRV—Narrows, Virginia
 WJWS—South Hill, Virginia
 WAFB—Staunton, Virginia
 WHEE—Martinsville, Virginia
 WCHV—Charlottesville, Virginia
 WEVA—Emporia, Virginia
 WNRG—Grundy, Virginia
- KOFE—Pullman, Washington
- WHJC—Matewan, West Virginia
 WELC—Welch, West Virginia
 WCFE—Parkersburg, West Virginia
- WTRW—Two Rivers, Wisconsin
 WCHF—Chippewa Falls, Wisconsin
 WSWW—Platteville, Wisconsin
 WAPL—Appleton, Wisconsin
 WOKW—Sturgeon Bay, Wisconsin
- CFCL—Timmons, Ontario, Canada
 CFDA—Victoriaville, Quebec, Canada
 CJSO—Sorel, Quebec, Canada
 CHED—Edmundton, Alberta, Can.
 CJKX—Yorkton, Sask., Canada
 CCGV—Quebec, Quebec, Canada
 CFGT—St. Joseph D'Alma, Quebec, Canada
- CBY—Cornerbrook, Newfoundland, Canada
 CKMR—Newcastle, New Brunswick, Canada
 CHRL—Roberval, Quebec, Canada
- KUAM—Agana, Guam
- XEOR—Reynosa, Mexico
 XEAS—Nuevo Laredo, Mexico
 XEKL—Jalapa, Ver., Mexico
 XEMJ—Piedras Negras, Coah., Mexico
- YNBH—Managua, Nicaragua
- WITA—San Juan, Puerto Rico
 WTIL—Mayaguez, Puerto Rico
 WABA—Aguadilla, Puerto Rico

NOTE: Errors caused by omission in listing or errors caused by stations changing equipment by reason of power increase are unintentional. Majority of overseas installations have been omitted as well as U. S. Government installations due to space limitations and Security reasons.

BC-250GY 250-Watt Broadcast Transmitter



A world-wide reputation for long trouble-free service. The most used 250 watt broadcast transmitter in America. Walk in to service, big component design and extra generous facilities. — The Gates BC-250GY transmitter is rightfully called, "The work horse of the broadcast industry."

Gates offers the choice of two transmitters in the 250 watt field. Where operation may exceed 250 watts at a later date, the BC-250L transmitter, listed on Page 33, is the logical choice. — If the frequency allocation will never permit increase in power, this model BC-250GY is the proper selection.

(Continued next page)

GATES

BC-250GY 250 Watt Broadcast Transmitter

CONSTRUCTION: In the BC-250GY transmitting plant is an assemblage of large heavy parts strategically placed for instantaneous accessibility. This, added to walk-in-to-service design, not only brings the admiration of the technical staff but spells cool, reliable operation. Generous spacing of components with the entire center of the cabinet free air, just naturally brings this result. Built in a cabinet 78" high, 40" wide and 33" deep and finished in hand rubbed gloss gray. Oscillator deck slips out in seconds if need be. Audio deck hinges out to reach under components. Full length hinged interlocked rear door is provided.

RADIO FREQUENCY: Three stages, provision for 2 crystals in temperature controlled ovens, 813 RF driver provides abundance of drive and long tube life, 2 type 810 single ended power amplifiers feed an output coupling network that will match impedances from 30 to 300 ohms.

AUDIO FREQUENCY: Two push-pull stages allows ample gain and low operating cost.

Class B high level 810 tubes assure extra tube life. Modulation reactor is part equipment and often omitted in 250 watt equipments.

METERING: Eight meters, more than in any other 250 watt broadcast transmitter. Includes: oscillator plate, RF driver plate, PA grid, PA plate, plate volts, filament volts, modulator plate and RF output. There is no multi-metering in the BC-250GY transmitter.

POWER SUPPLIES: Two power supplies develop the high voltage, intermediate and bias voltages for the entire transmitter. 8008 full wave rectifiers replace the smaller 866A rectifiers for added reliability.

PROTECTIVE RELAYS: Like all Gates transmitters, relays largely replace circuit breakers. Adaption to remote control, as well as full protection is complete in this type design. Two overload relays for power amplifier and modulator are incorporated plus plate contactor relay and vacuum time delay relay. Ease of attaching remote control is self-evident.

(Continued next page)

Rear illustrations show roomy big transmitter design with walk-in-to-service feature. From the standpoint of service and maintenance no transmitter built today has such accessibility.

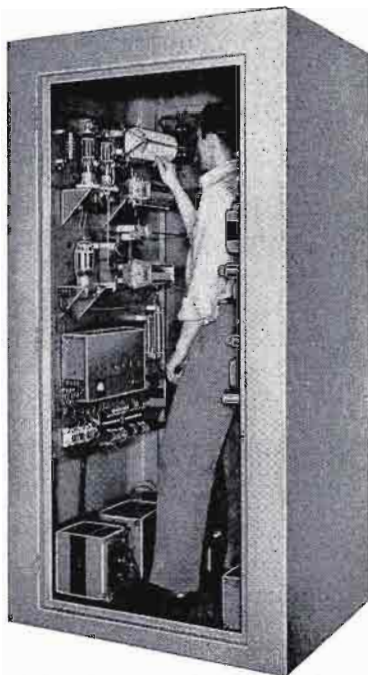
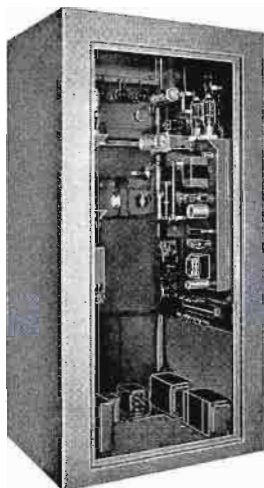

Broadcasting's Most Used 250 Watt Transmitter

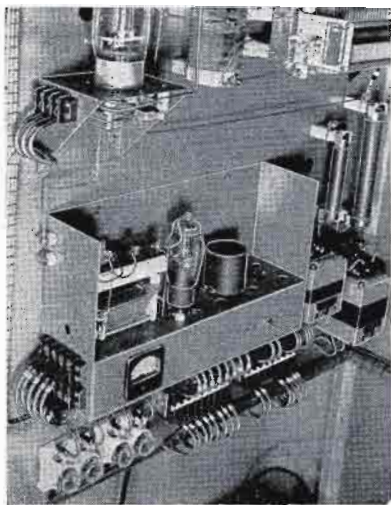

Oscillator unit (dust cover removed) accommodates two crystals and ovens, has its own tuning meter and may be removed in seconds.

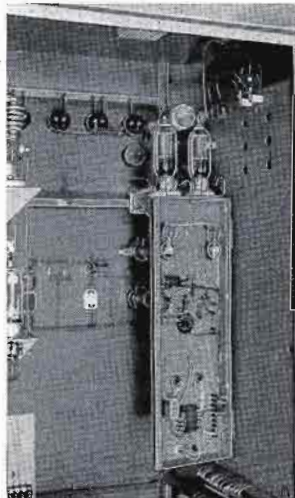

100% serviceability is always foremost in Gates designs. Here the audio deck hinges out to reach the under chassis parts.

POWER RESISTORS: All heavy sized power resistors are of the ferrule or plug-in type. This not only assures easy replacement but is indispensable for cleaning and assures no breakage during shipment.

COOLING: As the large roomy design allows convex cooling, the absence of blowers or fans assures quiet operation. In properly treated room design operation may be near a microphone, though it is always recommended that the transmitter be isolated from operating procedures by a glassed partition or similar.

TRANSFORMERS: As all Gates transmitters

are designed for 50 and 60 cycle operation, the transformers must be built with larger core and coil sections. This offers extra conservatism to 60 cycle users and no waiting for 50 cycle users. Generally there are no multi-transformers or the load is divided through several filament transformers and filter reactors instead of combining.

PERFORMANCE: Low distortion and noise, wide frequency response and excellent stability, both RF and in regulation of the power supply, forms a smooth sounding equipment that will delight musical audiences, and develop the rich full quality required in all programming.

(Continued next page)



Complete businesslike installation of BC-250GY transmitter and associated equipment is well illustrated in this photograph from KPAT, Pampa, Texas.

BC-250GY Specifications --- Ordering Data

SPECIFICATIONS

RATED POWER OUTPUT: 250 watts.

CAPABLE POWER OUTPUT: 280 watts.

STABILITY: ± 5 cycles.

FREQUENCY RESPONSE:

$\pm 1\frac{1}{2}$ db 30-10,000 cps.

± 2 db 30-12,000 cps.

DISTORTION: 50-8000 cps 2.8% or less at
95% modulation.

NOISE: 60 db or better below 100% mod.

RF OUTPUT IMPEDANCE: 30-300 ohms
(as ordered).

RF RANGE: 540-1800 Kc (as ordered).

AUDIO INPUT: 600 ohms balanced at +14
dbm ± 2 db.

POWER INPUT: 230 volt, 2 wire, single phase.

POWER CONSUMPTION: 1.6KW at 95% mod.

TUBES: 807 oscillator, 813 IPA, (2) 810 power
amplifiers, (2) 6L6 (1622) audio drivers,
(2) 810 Class B modulators, (2) 8008
rectifiers and 5Y4G rectifier.

WEIGHT AND CUBAGE: 900 lbs. packed.
Cubage, 112.

SIZE: 78" high, 40" wide, 33" deep.
Rear door swing 32".

ORDERING INFORMATION

	Cat. No.
Complete 250 watt broadcast transmitter with one set of tubes, crystal and oven	BC-250GY
100% spare tube complement for BC-250GY transmitter	M-3074
FCC spare tube complement for BC-250GY transmitter	TK-201
Extra crystal and oven for BC-250GY transmitter	JK57M

PRICES: Full prices on pink supplemental sheet in the back of this catalog.

NOTE: Be sure to state carrier frequency and RF output impedance when ordering.
For monitors, antenna couplers and other accessories, please refer to Index in back of catalog.

Functional diagram of BC-250GY transmitter.
866A tubes shown have been enlarged to 8008 tubes for further reliability.

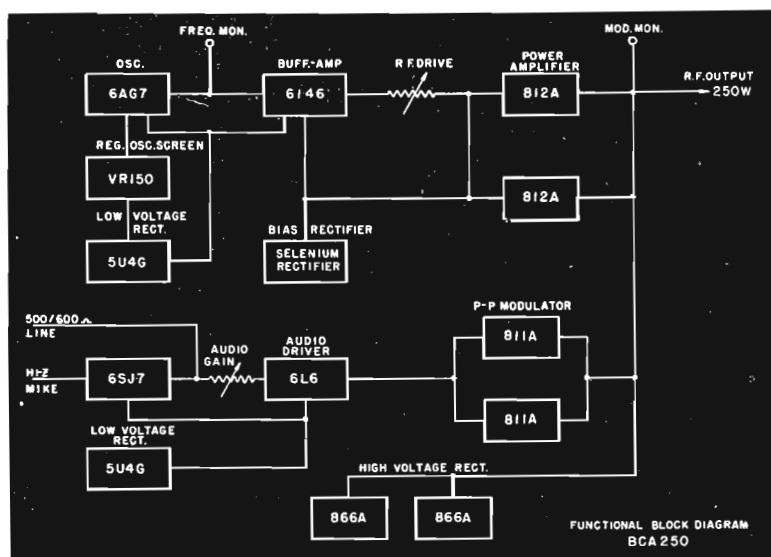

GY-48 COMPLETE PACKAGED RADIO STATION



A complete 250 watt radio station ready to attach to audio input and RF output. Even includes 12" monitoring loudspeaker. Consists of BC-250GY transmitter, MO-3066A accessory cabinet described on Page 61, joiner styling panel and complete interconnecting coaxial cables to attach monitors to transmitter.

This package has everything necessary for the 250 watt transmitting plant. Supplied are frequency and modulation monitors, limiting amplifier, input switching panel, matching DM-1X rack cabinet and all wiring. Sufficient room is provided in the bottom of the rack cabinet for adding remote control where desired. The monitoring loudspeaker attaches to the high level output of the modulation monitor which is direct off the air monitoring.

Complete 250 watt radio station with one set of tubes,
crystal and oven Cat. GY-48A

PRICES: See pink supplemental sheet in the back of this catalog.

NOTE: Be sure to state carrier frequency and RF output impedance when ordering. For spare crystal or spare transmitter tubes, see Page 46. Call letter plate is for illustrative purposes, at one time assigned to Quincy, Ill.

GATES

250 WATT AUXILIARY TRANSMITTER

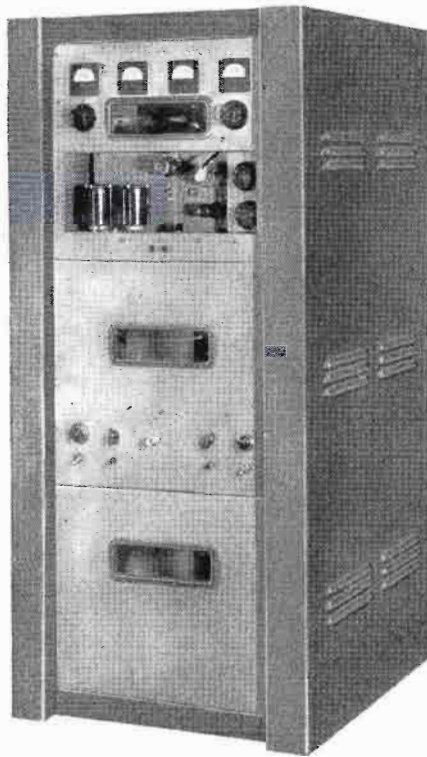

Model BCA-250

Transmitters in broadcast service and employed for standby, auxiliary and Conelrad service, need not meet the same FCC specifications as the main transmitting plant. — This allows certain economies in manufacturing and resultant lower selling price and still providing excellent transmission quality and reliability.

In case of failure of the main transmitting plant for any cause, no matter how small, the technical personnel switches over to the BCA-250 transmitter without lost air time or revenue. Available with or without Conelrad. Where Conelrad is desired, change to 1240 or 640 Kc is by means of a front panel switch and the second crystal is ordered at the Conelrad frequency.

(continued next page)

250 WATT AUXILIARY TRANSMITTER

SPECIFICATIONS

- FREQUENCY RANGE: 530-2000 Kc.
 POWER REQUIREMENTS: 115 volts, 60 cycles, 1100 watts.
 FREQUENCY STABILITY: ± 10 cycles.
 AUDIO INPUTS: 600 ohms +10 dbm. Also for Hi-Z microphone.
 RESPONSE: ± 2 db 100-5000 cycles.
 DISTORTION: 5% or less 100-5000 cycles, 90% modulation.
 NOISE: 50 db below 95% modulation.
 RF OUTPUT IMPEDANCE: 50, 70 or 250 ohms as ordered. Also available on special order for direct connection to wire antenna.
 CONELRAD: Available for operation on second frequency of either 1240 or 640 Kc. Front panel control.
 TUBES: 6AG7 osc., 6146 IPA, (2) 812A Power amplifiers, 6SJ7 microphone amplifier, 6L6 driver amplifier, (2) 811A modulators, (2) 866A rectifiers, (2) 5U4G rectifiers.
 SIZE: 50" high, 23" wide, 26" deep.
 FINISH: Medium gray.
 WEIGHT: Approximately 600 lbs. packed.

ORDERING DETAIL

Cat. No.

Transmitter with tubes, less crystal and oven	BCA-250
Transmitter with tubes and with Conelrad provision, less crystal and oven	BCA-250CR
Complete 100% set spare tubes	TK-157
Crystal and oven	JK57M

NOTE: Be sure to specify frequency of operation, Conelrad frequency (when ordered) and RF output impedance. Gates products are subject to electrical or mechanical change where improvement in product or manufacturing economies result, and without notice.

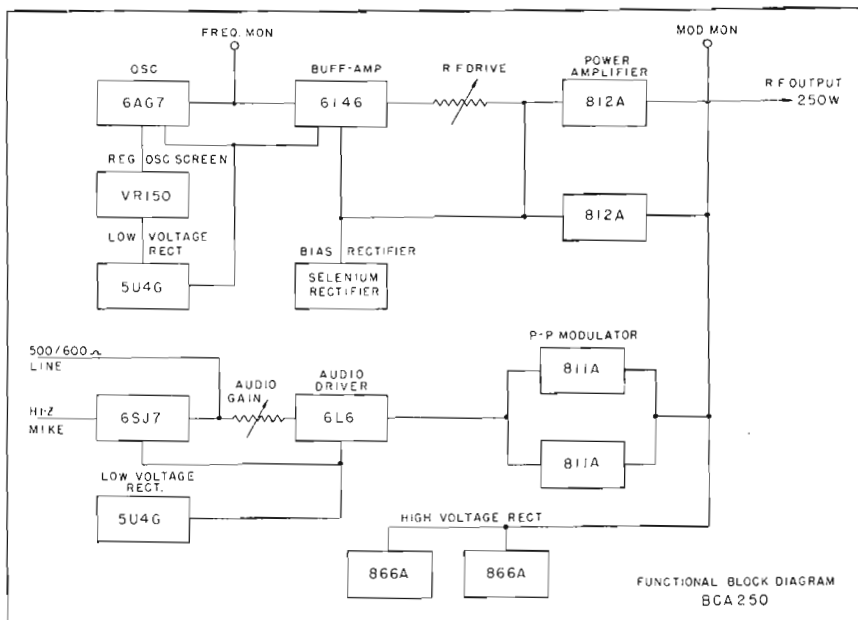

NEW 3KW FM BROADCAST TRANSMITTER

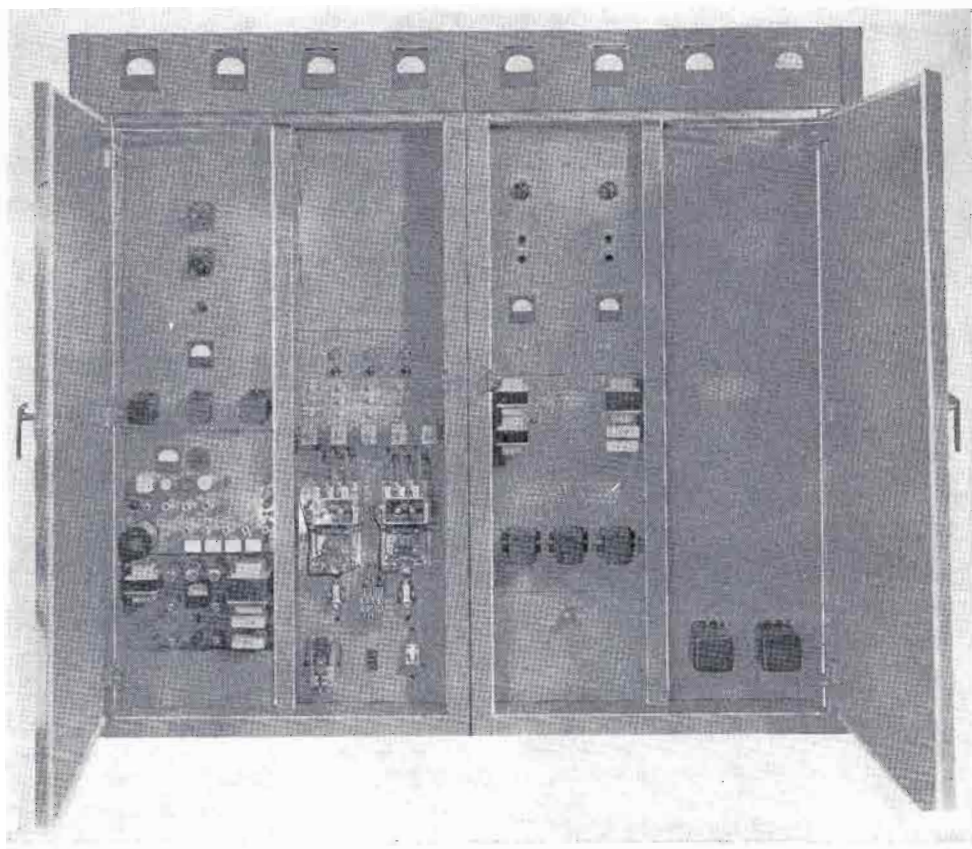

With the advent of multicasting and the increasing use of FM in many areas, demands are for a new modern, high power FM transmitter. The Gates BF-3E, designed entirely new in 1955, is the only new FM broadcast transmitter in recent years. Embodies a new pulse time modulator circuit using standard receiving type tubes. These tubes may be replaced without need of readjustment for best performance standards.

Output circuit incorporates push-pull 4-1000A tubes for long life. Distortion between 50 and 15,000 cycles is less than 1½% at maximum modulation. A heavy transmitter for around the clock service with a full complement of meters, protective relays and generously rated components.

FOR 88-108 MC FM BROADCASTING

EXCITER: The exciter/modulator includes a crystal controlled oscillator, pulse time modulator, audio amplifier and a number of frequency multipliers—multiplying 864 times between the oscillator and carrier frequency. A meter in the exciter reads cathode current for oscillator and multiplier tubes.

IPA DRIVER: Is two 4X150A tubes push-pull operating on the fundamental frequency. Plate circuit is a quarter wave linear element tank with shorting bar for tuning to frequency. A variable condenser supplies final tuning on frequency.

POWER AMPLIFIERS: Two 4-1000A tubes are forced air cooled. Quarter wave linear para-

meters are employed in the grid and plate circuits for maximum stability and efficiency. Tank circuit is motor tuned for ease in adjustment and optimum placement of tank circuit components. RF output impedance is 50 ohms.

OUTPUT METER: For reading power output in watts and VSWR is standard equipment.

POWER SUPPLIES: Four power supplies include: (1) low voltage regulated supply for exciter/modulator, (2) 600 volt screen voltage supply, (3) 1000 volt plate supply for IPA, and (4) 4200 volt plate supply for the final power amplifier. Input is 230 volts, 3 wire, 3 phase.

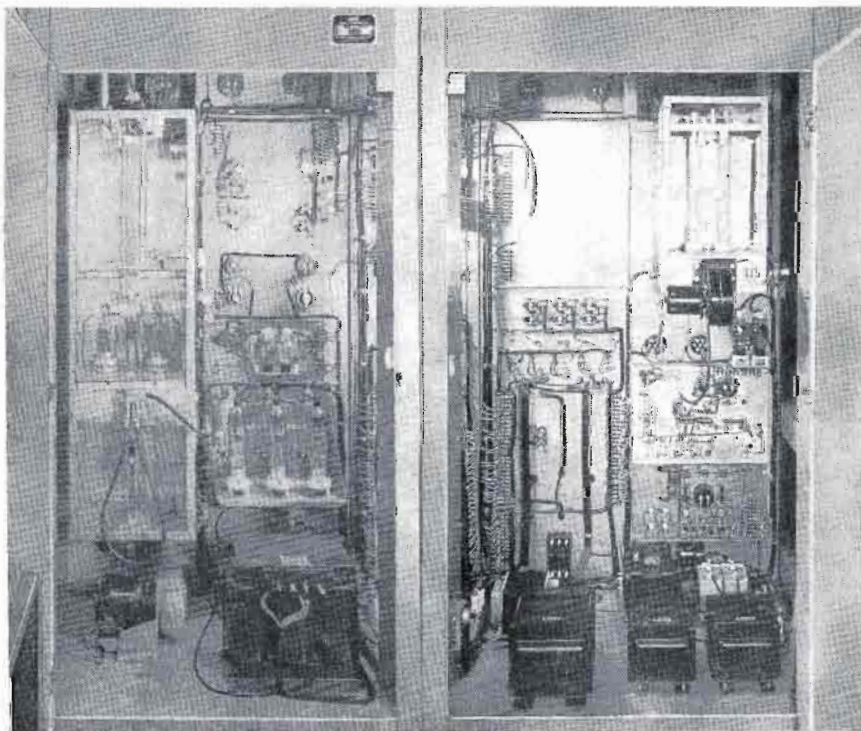

BF-3E 3KW FM BROADCAST TRANSMITTER

PROTECTIVE EQUIPMENT: Is 100% complete. A pressure switch in the main air chamber of the IPA and PA stages protects tubes at all times against air failure. Overload relays, time delay relay, filament and plate contactors, door interlock and all fail-safe provisions are incorporated. Added secondary circuit breaker protection is also incorporated.

METERING: Eight 4" meters and four smaller meters more than adequately meter every circuit including the direct reading power output meters.

CONSTRUCTION: Is in two heavily built cubicles with two doors on the front and two nearly identical doors on the rear. Dead front design is employed which allows opening of front doors for all tuning without interlocks. Rear doors are interlocked. Transmitter stands 78" high, 89" wide and 35" deep, with 37" door swing. Finish is in hand rubbed gloss gray for ease in cleaning.

PERFORMANCE: More than meets all FCC requirements for FM radio broadcasting. Lower noise is made possible in well filtered circuits, strict attention to the Q in exciter circuits and the use of a 3-phase power supply. The technically minded will note the oversize tubes for long trouble-free life in both driver and power amplifier.

Complete tuning is from the front. After adjustments are made, the front doors protect these adjustments by remaining closed at all times. The BF-3E transmitter is easily adapted to remote control.

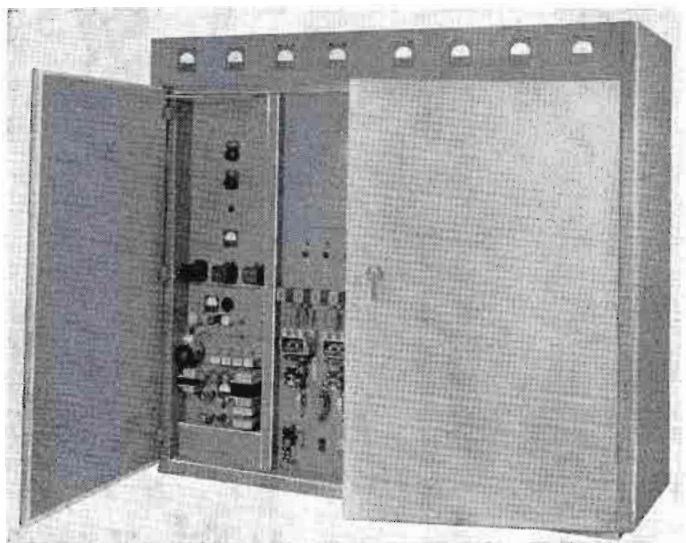

Specifications --- Ordering Data BF-3E

SPECIFICATIONS

- POWER OUTPUT: 3000 watts nominal rating.
- FREQUENCY RANGE: 88 to 108 Mcs.
- RF OUTPUT IMPEDANCES: 51.5 ohms with maximum SWR 1:1.5.
- TYPE OF OSCILLATOR: Direct crystal control.
- FREQUENCY STABILITY: $\pm .001\%$ on carrier frequency.
- TYPE OF MODULATION: Phase shift.
- MODULATION CAPABILITY: ± 100 Kc.
- AUDIO INPUT IMPEDANCE: 600 ohms.
- AUDIO INPUT LEVEL: Approximately 10 dbm ± 2 db.
- FREQUENCY RESPONSE: ± 1 db 50 to 15,000 cycles with ± 75 Kc swing as reference.
- DISTORTION: Maximum $1\frac{1}{2}\%$, 50 to 15,000 cycles.
- TUBE COMPLEMENT: One each, 6BA6, 6146, 6SH7; two each, 12AY7, 12AX7, VR105, 5U4G, 4X150A, 4-1000A; three each, 6AS7, 575A; four each, 6AH6, 866A.
- POWER REQUIREMENTS: 230 volts, 60 cycles, 3 phase, at 9 KVA.
115 volts, 60 cycles, single phase, at 500 watts.
- DIMENSIONS: 89" wide, 78" high, 35" deep.
- WEIGHT: Approximately 1800 lbs.
- CUBAGE: 143 cu. ft.

ORDERING INFORMATION

- 3KW FM broadcast transmitter complete with one set of tubes,
one crystal and oven Cat. BF-3E
- 100% spare tube complement for BF-3E Cat. TK-224
- Spare crystal and oven Cat. JK07E

PRICES: See pink supplemental sheet in the back of this catalog.

NOTE: Be sure to state carrier frequency in megacycles when ordering.

250 WATT ALL-PURPOSE FM TRANSMITTER

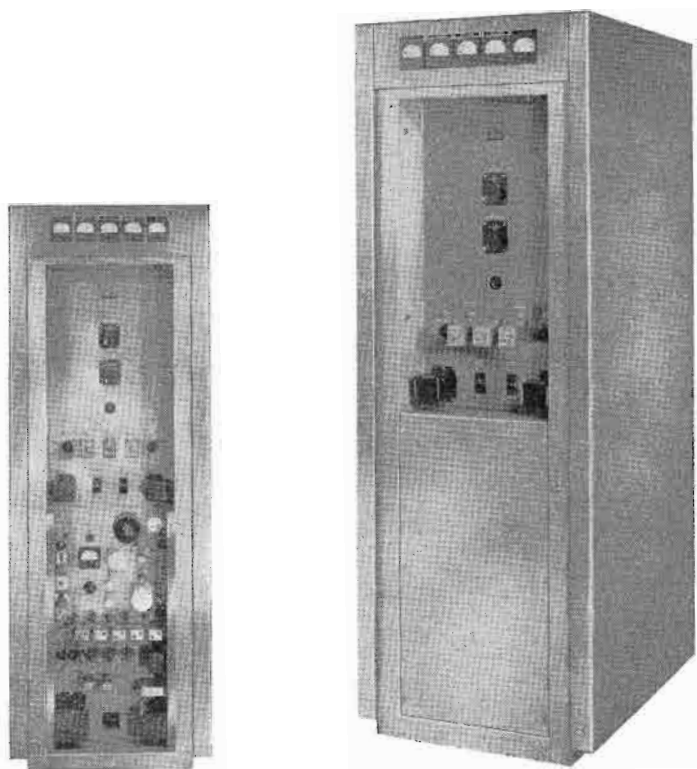

The Gates FMR-250 may be purchased: (a) as a 250 watt FM broadcast transmitter operating between 88-108 Mc, (b) as an FM transmitter with full fidelity ± 75 Kc swing operating between 150-200 Mc, and (c) as a transmitter to operate at any frequency between 88 and 228 Mc with ± 25 Kc swing.

Application of this transmitter is over a wide range of service including radio broadcast, studio-transmitter link*, point to point, relay and ground to air service. Phase modulation, embodying pulse techniques, requires no readjustments at time of tube change to maintain full performance standards.

* Depending on frequency allocation in various countries.

(continued next page)

250 WATT ALL-PURPOSE FM TRANSMITTER

This transmitter is commercial all the way. Designed in a rugged steel cabinet with removable side bells and full size back door. Front lower cover protects the exciter unit and is instantly removable. Outstanding FMR-250 feature is the rugged simplicity in design, eliminating many of the complex features associated with FM.

Operation at powers under 250 watts is easily possible. The LV power supply is of the regulated type for stable performance. Complete blower cooling with filtered air intake assures continuous high performance in all climates. Automatic overload protection is elaborate in every detail. Line voltage correction switch is provided on front panel. Such nice refinements as internal service light when back door opens and power receptacle are provided.

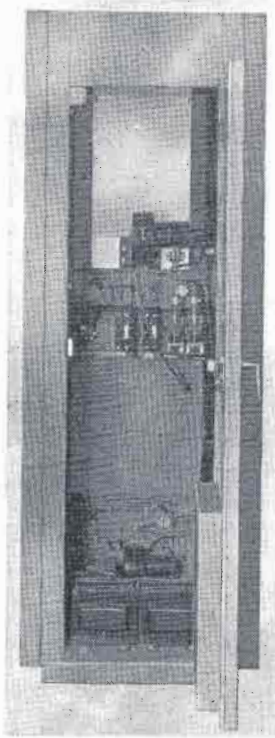

SPECIFICATIONS

POWER OUTPUT: 250 watts up to 200 Mc, 175 watts 200-228 Mc.

FREQUENCY COVERAGE: Model FMR-250, 150-200 Mc.

Model FMR-250B, 88-108 Mc.

Model FMR-250E, 88-228 Mc.

(single frequency operation as specified when ordering.)

MODULATION: FM ± 75 Kc max. swing, except FMR-250E ± 25 Kc.

DISTORTION: 1.5% maximum ± 75 Kc swing.

NOISE (FM): 60 db below ± 75 Kc.

NOISE (AM): 55 db below 100% modulation.

FREQUENCY RESPONSE: $\pm 1\frac{1}{2}$ db 50-15,000 cycles. Where specified, high frequencies may be cut off at any point desired.

IMPEDANCES: AF input 600 ohms at $+10$ dbm. RF output 51 $\frac{1}{2}$ ohms.

PRE-EMPHASIS: Separate plug-in 75 micro/sec pad when requested.

POWER INDICATOR: Direct reading power output meter indicates both watts and standing wave ratio.

POWER INPUT: 105/125 volts, 50/60 cycles, single phase, 2 wire. Other voltages available on special order.

METHOD OF MODULATION: Phase, employing pulse techniques.

TUBES: Models FMR-250 and FMR-250E: 5 each 6SJ7; 3 each 6AS7; 2 each 5U4G, 866A, 12AY7, 4X150A; 1 each 6AG7, 6SN7, 6V6, 815, 829B, VR-105, 6SH7, 12AX7, 6BA6.

Model FMR-250B: 4 each 6AH6; 3 each 5763, 6AS7; 2 each 12AY7, 12AX7, 5U4G, 866A, 4X150A; 1 each 6BA6, 6146, 6SH7, VR-105.

FREQUENCY STABILITY: ± 0.001 %.

SIZE AND FINISH: 27 $\frac{1}{2}$ " wide, 36" deep, 78" high. Finish, two-tone, hand rubbed gloss gray with escutcheons in black.

WEIGHT: Packed, 1005 lbs. Net, 715 lbs. Cubage 96.

ORDERING DETAIL

Transmitter for 88-108 Mc broadcast model with tubes, crystal and oven Cat. FMR-250B

Transmitter for 150-200 Mc full fidelity model ± 75 Kc swing, with tubes, crystal, oven Cat. FMR-250

Transmitter for any frequency between 88 and 228 Mc with ± 25 Kc swing, with tubes, crystal and oven Cat. FMR-250E

100% set of tubes for FMR-250B transmitter Cat. TK-169

100% set of tubes for FMR-250 and FMR-250E Cat. M4054

Spare crystal and oven (state frequency) Cat. JK07-E

NOTE 1: Specify exact frequency of operation when ordering.

NOTE 2: Prices provided on pink supplemental price list in back of catalog.

NOTE 3: Allow reasonable length of time for testing on frequency and/or special frequencies required.

GATES

55

FM Broadcast Transmitters, 10 and 50 Watts

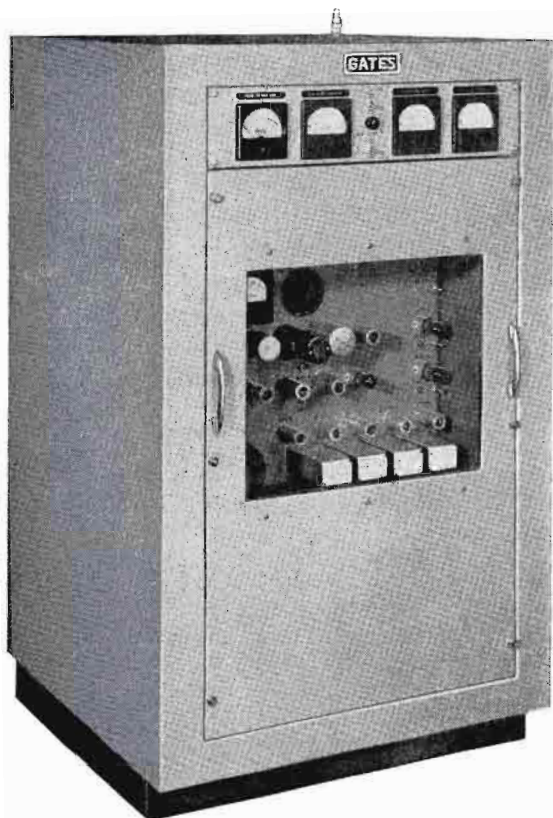

Includes:

- Modulation percentage meter.
- Factory pre-tuned to frequency.
- New low cost tube complement.
- Completely self-contained.
- Metering for all major circuits.
- 100% accessibility for servicing.

A new series of FM transmitters in the 88-108 Mc range, particularly designed for the educational broadcast field but usable in many countries for studio-transmitter links, relay and other related services. — Modest size permits under window sill or desk mounting.

Both models are completely self-contained and require no external accessories other than speech input and antenna equipment. A new and greatly simplified frequency modulation system, employing pulse techniques, uses standard receiving type tubes, and requires no readjustment after tube change.

(Continued next page)

FM Broadcast Transmitters, 10 and 50 Watts

Models BF-E-10A and BF-E-50A are identical other than power output rating. The 50 watt model BF-E-50A has two added power amplifier tubes and a second power supply. Constructed in a sturdy steel cabinet 38" high, 24" wide and 20" deep, finish is in hand rubbed gloss gray. Front and back doors removable for easy servicing.

Variable controls have been reduced to a bare minimum for ease in tuning and retaining at high performance standards. — Basic design consists of a crystal controlled oscillator, pulse time modulator, audio amplifier, frequency multipliers and output amplifier. Pulses are developed from the oscillator output and applied to the modulator. Crystal frequency is between 102-125 Kc and is multiplied 864 times to arrive at the output frequency.

Power supply is regulated. Five meters are provided to read: (a) all RF tubes plate current, (b) selective output power, (c) power amplifier plate current, (d) plate voltage, and (e) modulation percentage. — The entire unit may be turned on and off with a single primary switch, making it ideal for simple remote control operation.

SPECIFICATIONS

POWER OUTPUT: BF-E-10A: 10 watts.
BF-E-50A: 50 watts.

FREQUENCY RANGE: 88-108 Mc.

RF OUTPUT IMPEDANCE: 51 ohms.

FREQUENCY STABILITY: $\pm .001\%$.

MODULATION CAPABILITY: ± 100 Kc.

AUDIO INPUT IMPEDANCE: 150/600 ohms.

AUDIO INPUT LEVEL: $+10$ dbm, ± 2 db.

FREQUENCY RESPONSE: Within $1\frac{1}{2}$ db of standard 75 micro-second preemphasis curve.

DISTORTION: $1\frac{1}{2}\%$ or less, 50-15,000 cycles.

NOISE: 60 db below 100% modulation (FM).
55 db below 100% modulation (AM).

POWER INPUT: 115 volts, 50/60 cycles. BF-E-10A, 300 watts.
BF-E-50A, 450 watts.

TUBES: Model BF-E-10A: one each 6BA6, 6146, 6SH7; two each 12AY7, 12AX7, OC3, 5U4G; three each 5763; four each 6AH6.

Model BF-E-50A: same as BF-E-10A with two each 6146 and 5U4GA added.

SIZE: 38" high, 24" wide, 23" deep.

WEIGHT: Unpacked, 163 lbs. Packed, 260 lbs.

CUBAGE: 22 cu. ft.

NOTE: For antennas used with this equipment, see FM-11 (See Page 254).

ORDERING INFORMATION Cat. No.

BF-E-10A Transmitter with tubes, crystal and oven **M-4844**
 BF-E-50A Transmitter with tubes, crystal and oven **M-5219**
 100% spare tube complement for BF-E-10A **TK-187**
 100% spare tube complement for BF-E-50A **TK-197**
 Spare crystal and oven **JK07E**

NOTE: Prices listed on pink supplement price sheet in back of this catalog.

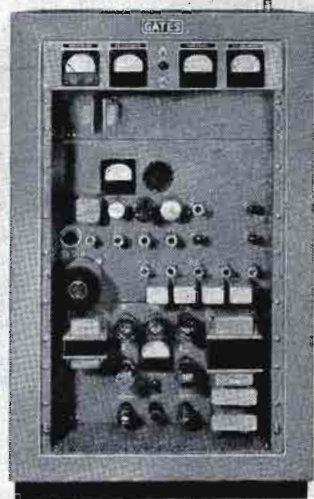

Top: Front view open.
Bottom: Rear view door removed.

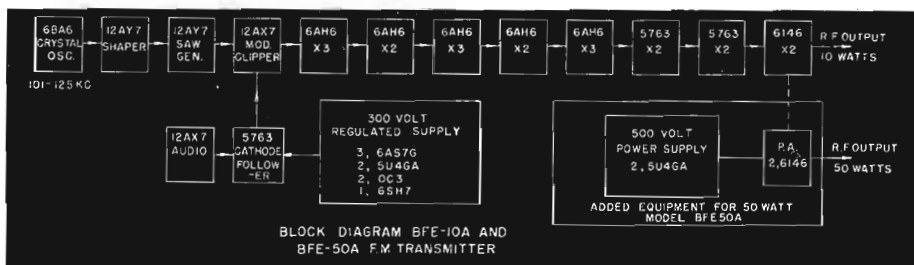
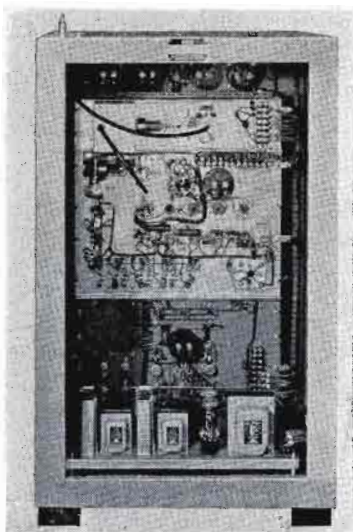

BROADCAST FREQUENCY MONITOR

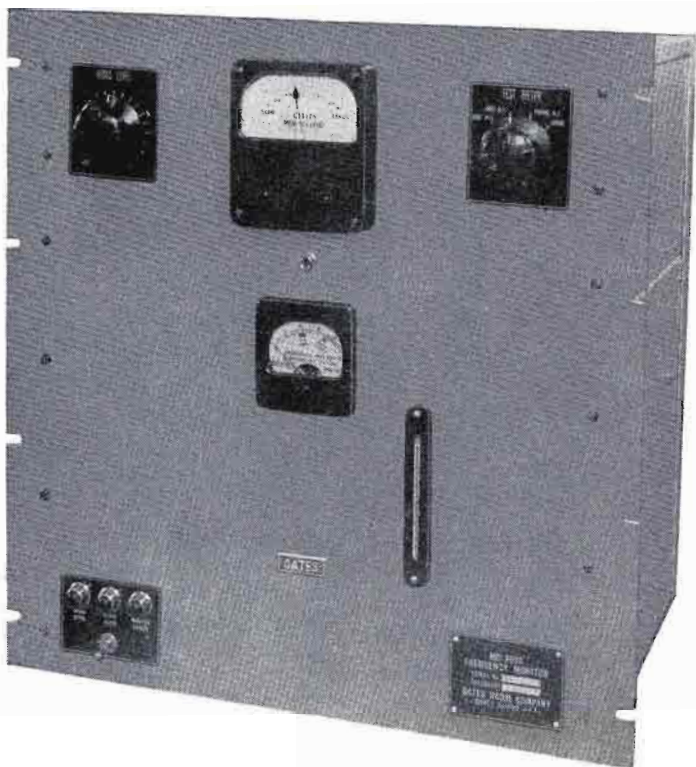

MO-2890 AM Frequency Monitor

A fully FCC approved frequency monitor with a proved service record — hundreds in American broadcasting stations. Ruggedly constructed and carefully tested to assure accuracy of better than five parts in a million. Combines straightforward, reliable circuitry with an unusual dual oven design for reliable on-frequency service.

Precision crystal oscillator operates at 5000 cycles below carrier frequency. The output is amplified by one stage and then mixed into a detector stage with a small amount of the RF signal from the transmitter. The resulting beat note is further amplified and then applied to the frequency meter. This meter is calibrated in one-cycle steps from -30 to $+30$ cycles with zero point at center scale. Phone jack is provided for aural monitoring. A 3" meter indicates the amount of RF signal feeding the frequency monitor. This same meter indicates oscillator current; oscillator signal voltage and signal voltage from transmitter.

(continued next page)

BROADCAST FREQUENCY MONITOR

Two ovens, one located inside the other, carefully guard accuracy. Inner oven is controlled by a mercury column thermostat operating at temperature variations of 0.2° . The crystal is located in this oven. Outer oven operates at slightly lower temperature, also at close temperature tolerance. This oven includes the tube and oscillator components. Front panel equipment includes the large 4" frequency meter, 3" radio frequency meter, oven indicating pilot lights, On-Off switch and pilot light, input signal adjusting control and meter selector switch. All connections and adjustments are easy to reach. Dust cover is quickly removable, with access openings for minor adjustments.

SPECIFICATIONS

OSCILLATOR ACCURACY: Better than five parts per million.

FREQUENCY METER CALIBRATION: One-cycle steps $-30-0+30$ allowing direct reading in one-cycle intervals.

RF DRIVING POWER: Approximately $\frac{1}{2}$ watt.

TUBES: 6AC7 oscillator, 6SJ7 RF amplifier, 6H6 detector, 6C5 mixer, 6SJ7 amplifier, 6V6 output amplifier, 5U4G rectifier, VR150-30 regulator.

POWER: 115 volts, 50/60 cycles at approximately 85 watts.

SIZE: 19" wide, 19 $\frac{1}{4}$ " high, 12" deep.

WEIGHT: Packed 125 lbs. Net 85 lbs.

CUBAGE: 16.

FCC APPROVAL NUMBER: 1469.

ORDERING DATA

MO-2890 Frequency Monitor complete with one set of tubes	\$695.00
M2951 100% spare tube complement	10.40

NOTE: Be sure to state carrier frequency when ordering.

Rear view illustrates dust cover removed from MO-2890 frequency monitor. Each monitor is laboratory tested on customer's frequency prior to shipment.

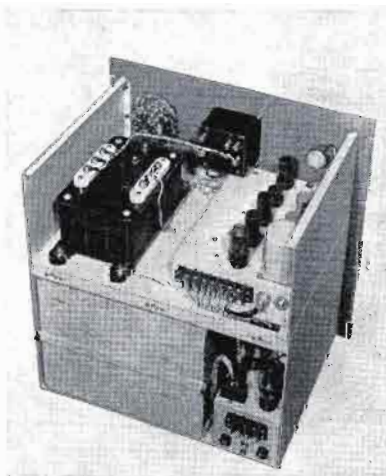
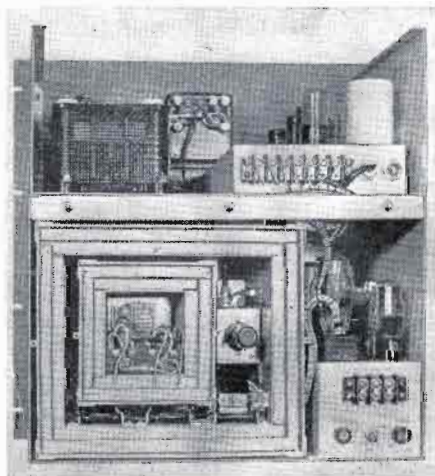

BROADCAST MODULATION MONITOR

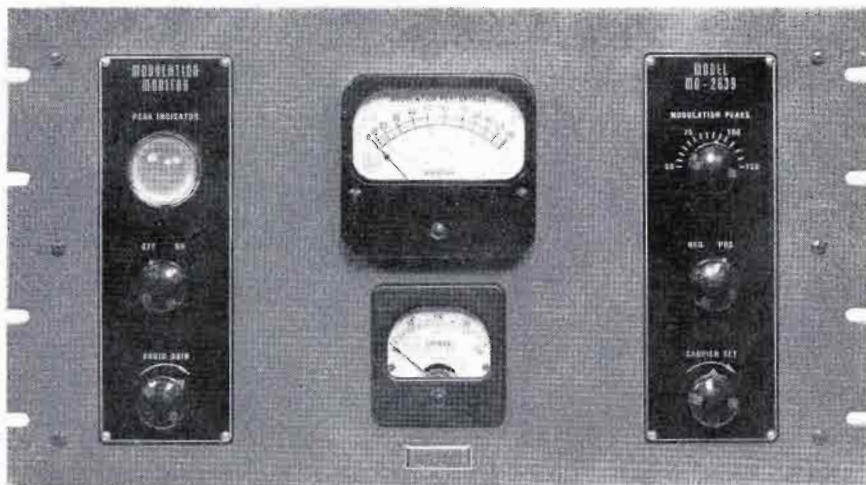

A fully FCC approved modulation monitor meeting all modern broadcast requirements, with a model available for both standard and high frequency service. Exclusive is the self-contained high level amplifier with sufficient power output to operate a loudspeaker for direct off-the-air monitoring.

The 4-inch modulation percentage meter is calibrated from -15 db to 0 db and 0-110% modulation. A neon lamp located behind a large bull's-eye on the front panel is adjustable to flash at any desired percentage of modulation. The 3-inch carrier meter allows direct center scale reading for proper RF input. Panel controls include:

- (a) Carrier set adjustment.
- (b) Positive-negative peak control.
- (c) Peak indicator adjustment.
- (d) Audio amplifier gain control.
- (e) Off-On switch.

Each monitor is carefully manufactured and tested in accordance with specifications set forth under FCC standards and carries FCC approval No. 1556.

SPECIFICATIONS

FREQUENCY RANGE: MO-2639, 100-2000 Kc.
 MO-2639A, 2-24 Mc.
 RF INPUT: High impedance requiring less than 1/2 watt excitation.
 LOUSPEAKER IMPEDANCE: 4 to 8 ohms.
 MODULATION PERCENTAGE RANGE: 0-110%.
 CARRIER LEVEL METER RANGE: 0-200%.
 DECIBEL SCALE RANGE: Calibrated to 15 db below 100% modulation.
 AUDIO AMPLIFIER: Range exceeds best quality speaker capabilities.
 POWER: 115 volts, 50/60 cycles at 65 VA.
 TUBES: 3 each 6X5, 6C5; 1 each 6F6, 885, VR-150.
 WEIGHT: Packed, 40 lbs. Net, 27 lbs. Cubage 4.
 DIMENSIONS AND FINISH: 19" wide, 10 1/2" high, 13 1/2" deep.
 Finish, medium hand rubbed gloss gray with escutcheons in black.

ORDERING DETAIL

MO-2639 modulation monitor complete with tubes	\$350.00
MO-2639A modulation monitor complete with tubes	410.00
TK-113 100% set of spare tubes	10.20

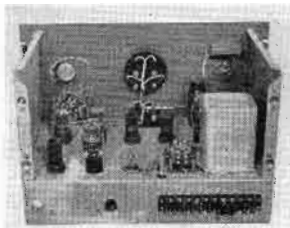

TRANSMITTER ACCESSORY UNIT

Model M-3066

Designed as packaged unit for use with all amplitude modulated broadcast installations. A complete rack cabinet equipment fully wired and ready to use. Includes from top to bottom:

- MO-2639 modulation monitor.
- MO-2890 frequency monitor.
- SA-38 limiting amplifier.
- Input switching panel.
- Blank panels.

Full description of monitors and limiting amplifier found on other pages in this catalog (see Index). Switching panel accommodates three 600 ohm input circuits, usually employed for duplicate telephone lines and a third input such as a microphone preamplifier, tape recorder, etc. A second switch is provided to bypass the limiting amplifier in case of emergency tube replacement.

Blank panel below switching panel provides room for additional expansion such as patch panels, amplifiers, etc. Sufficient solid dielectric coaxial cable is wired into the circuit and provided for attachment of monitors to adjacent transmitter.

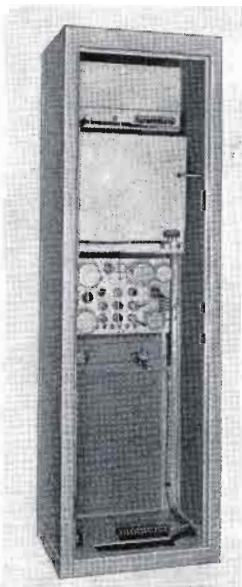
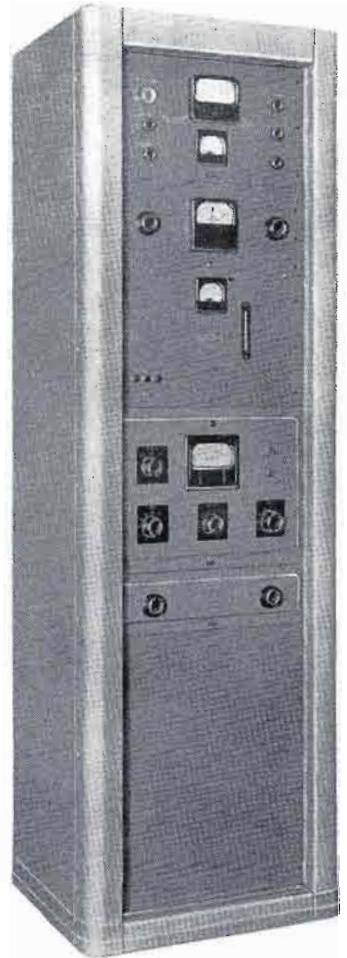

Left:
Complete accessory cabinet, fully wired, makes installation faster and performance assured.

SPECIFICATIONS

SIZE: 78" high, 23 1/4" wide, 20 1/2" deep.
FINISH: Medium gloss gray hand rubbed.
RACK CABINET: Model DM-1X.
SHIPPING WEIGHT: Approximately 300 lbs.
CUBAGE: 38.

ORDERING DATA

M-3066 Accessory Cabinet with tubes and includes SA-38 limiting amplifier\$1700.00
M-3066A same as above but includes SA-39 limiting amplifier in place of SA-38 1640.00

NOTE: For spare tube kits, see individual listing of monitors and limiting amplifiers. For FCC filing, specify type number of monitors only.

GATES

TRANSMITTER CONTROL CONSOLE

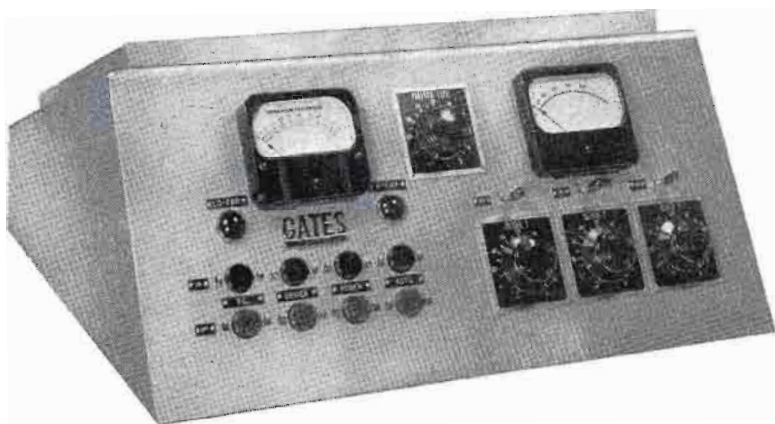

For use with any standard or short wave broadcast transmitter to provide several input circuits, extension audio indicating meters, remote start/stop functions and associated indicator lamps. Functional diagram at bottom of page outlines generous facilities available. Where desk is desired, see Index (Desks). Model CB-63 recommended.

SPECIFICATIONS

INPUTS: Three provided with line isolation transformer for each circuit, 50/150/600 ohms ladder type controls, 20 steps, 2 db each.

OUTPUT: 600 ohms

MASTER GAIN: Balanced 30 step, 1.5 db per step.

VU METER: 4" square case with range control +4 to +40 VU in two VU steps for bridging 600 ohm line. Scale illuminated.

MODULATION METER (CCD-2 only): Gates A1363-2 as used in MO-2639 modulation monitor. Scale illuminated.

PUSH BUTTONS: Four pairs provided (black start—red stop) to cover all possible combinations including automatic reset as featured in many Gates models.

PILOT LIGHTS: Provided to indicate filament and plate on.

FINISH: Medium hand rubbed gloss gray with escutcheons in black.

SIZE: 24" wide, 10" high, 21 1/2" deep. Cabinet swings up from base for servicing.

See illustration below.

SHIPPING WEIGHT: 60 lbs.

Ordering Data

CCD-2 Transmitter Control Console with extension modulation meter \$750.00

CCD-2A, same as above but modulation meter omitted and blank plate inserted... \$718.00



Above: Cabinet swings up to reach all parts for servicing.

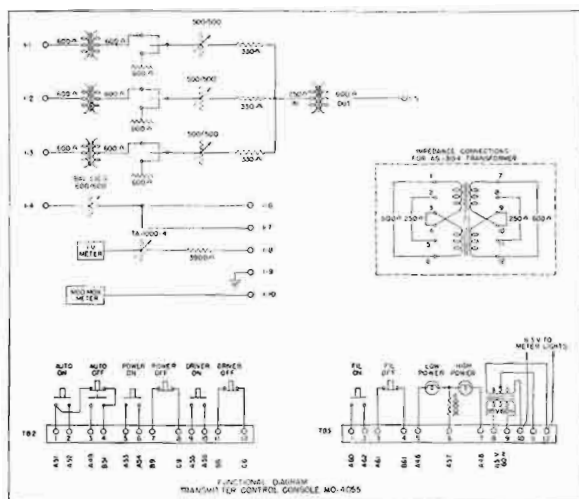

TRANSMITTER AUDIO CONTROL

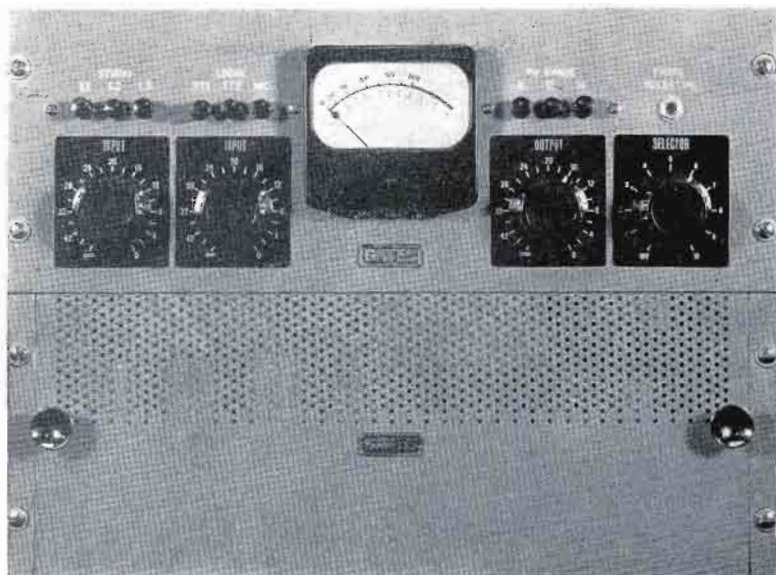

Provides all necessary facilities for complete audio control at the transmitter, including preamplification for microphone or turntables. From left to right: dial one controls 3 incoming 600 ohm lines at high level by means of push-button switch—for use with telephone lines, tape recorders, etc. Dial two handles two turntables and microphone, the latter through the preamplifier—push-button selected. Dial three, master gain. Dial four provides selection of headphones across 10 major circuits, both input and output. Push-buttons also select the VU range of +8, +12 and +16 VU.

VU meter is standard 4" illuminated. Preamplifier is Gates PRE4, program amplifier PGM4 and power supply is the popular regulated PWR3—all listed under audio equipment (see Index).

SPECIFICATIONS

IMPEDANCES: Line inputs (3), 600 ohms. Turntable/microphone input 50/150 ohms.
Line output 600 ohms.

GAIN: Microphone input to line output, 98 db. Turntable input to line output, 66 db.
Line inputs to line output, 52 db. All ± 3 db.

OUTPUT DATA: Rated +24 dbm or less at 1% distortion or less from 50-15,000 cycles.

RESPONSE: 30-15,000 cycles ± 2 db.

NOISE: 60 db or better below +8 dbm.

SIZE: 19" wide, 14" high, 14" deep.

POWER: 115 volts, 50/60 cycles.

WEIGHT: 75 lbs. packed. Cubage: 6.

ORDERING INFORMATION

M4912 Station Control Unit	\$775.00
TK-236 100% spare tube complement	21.35

GATES

RDC-10 DC REMOTE CONTROL SYSTEM



For top quality, modest cost handling of any single transmitter, the Gates RDC-10 system for unattended operation supplies every needed facility, and is backed by the world's major supplier of radio broadcast equipment.

Outstanding Features Are:

- 3 four-inch meters.
- 10 metering positions.
- 22 control functions possible.
 - Positive action switch for meter selection—no dialing.
- Built-in relays for switching both filament and plate voltage.
- Constant voltage source provided for line checking.
- Abundantly meets FCC requirements.
 - Drop down front panel to service.

(more next page)

Economy -- Reliability -- Serviceability -- Modern

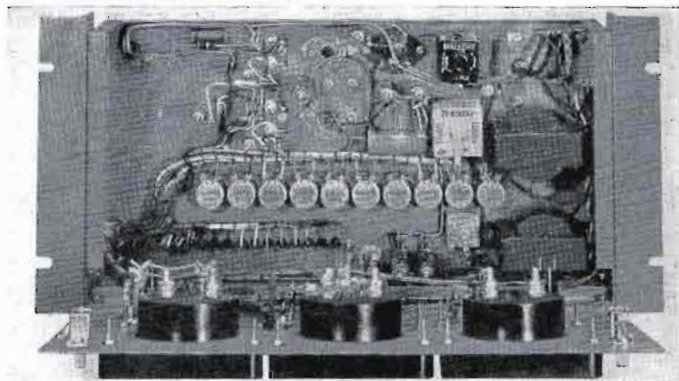

Studio unit has drop-down front panel so all parts can be reached from front of rack. Panel size of $8\frac{3}{4}'' \times 19''$ often conserves badly needed rack panel space.

THREE four-inch meters calibrated directly in DC volts, DC amperes and RF amperes assures accurate, easy to read metering even from across a room. Seven of ten metering circuits are directly connected. Three balanced stepping relay positions, brought to extra terminals, may be used for metering, studio-transmitter order phone and emergency program line.

CONTROL relays are inbuilt for filament and plate switching on and off as well as for controlling plate voltage via the motor tuned rheostat supplied. Fail-safe protection is provided on the filament control circuit. Up to 20 more switching functions may be handled by adding inexpensive relays though full facilities are provided in the standard equipment for broadcast transmitter operation.

WHAT IS SUPPLIED: Both studio and transmitter units as illustrated, plus M-4703 motor control plate voltage rheostat listed Page 70, antenna diode unit M-3759 for reading antenna current listed Page 70, M-4720 plate current unit for reading plate current of transmitter, M-4719 plate voltage unit for reading plate voltage and the inbuilt tower light indicator with external current transformer.

INSTALLATION is speedily and easily made. Basic units (studio and transmitter) are each $8\frac{3}{4}'' \times 19''$ in panel size. Terminal boards assure quick attachment of interwiring.

(Continued next page)

The transmitter unit is absent of front panel controls, has drop down front panel to service and only requires $8\frac{3}{4}'' \times 19''$ panel space. Small size even allows mounting in some transmitters, where room prevails.

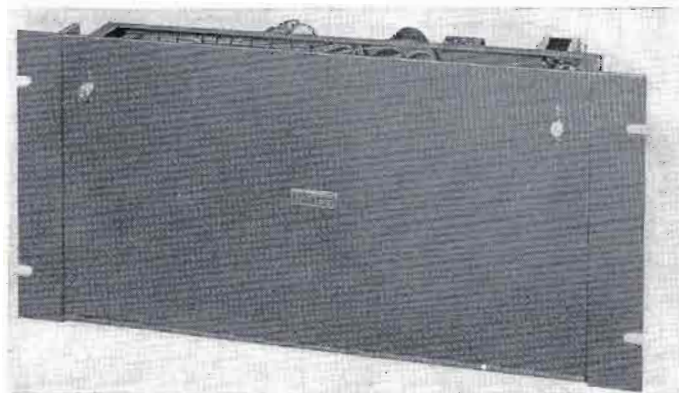

Model RDC-10 For Unattended Operation

RECOMMENDED USAGE: May be used with all Gates broadcast transmitters listed in this catalog. 250, 500 and 1000 watt models require no basic equipment additions for transmitter remote control. — 5000 to 10,000 watt models usually require added motor tuning unit for variable loading coil. See page 70.

REMOTE MONITORING: Is accomplished through use of several accessories listed on following pages. Where modulation and/or frequency monitors are moved to studios, the model M-5144 RF amplifier is added. See page 71.

WHEN ORDERING: State carrier power, make of transmitter, model number of transmitter, carrier frequency and where applicable, type of frequency and modulation monitors.

ORDERING INFORMATION

- RDC-10 Remote control system complete with motor tuned rheostat, antenna diode, plate and voltage metering kits and tower light indicator, for powers up to and including 1KW \$795.00**
- RDC-10A, same as above but for powers up to and including 10KW 895.00**

Functional line drawing of RDC-10 Remote Control System.

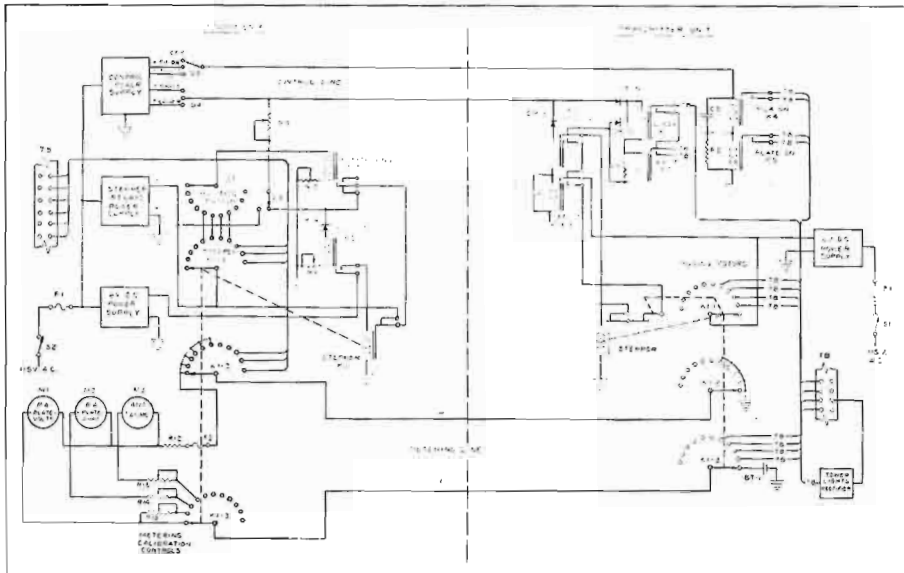

RCM-20 Tone Operated Remote Control System



Above and below, front and rear views of the studio unit of the RCM-20 remote control system for unattended operation.

With both the present and future in mind—Gates engineers have developed what is believed by many to be the finest and most extensive remote control system ever built. — Six tone channels handle control facilities and up to 38 switching functions are possible. No dialing is employed. — For stations that may have future directional requirements, this model will receive much attention.

(Continued next page)

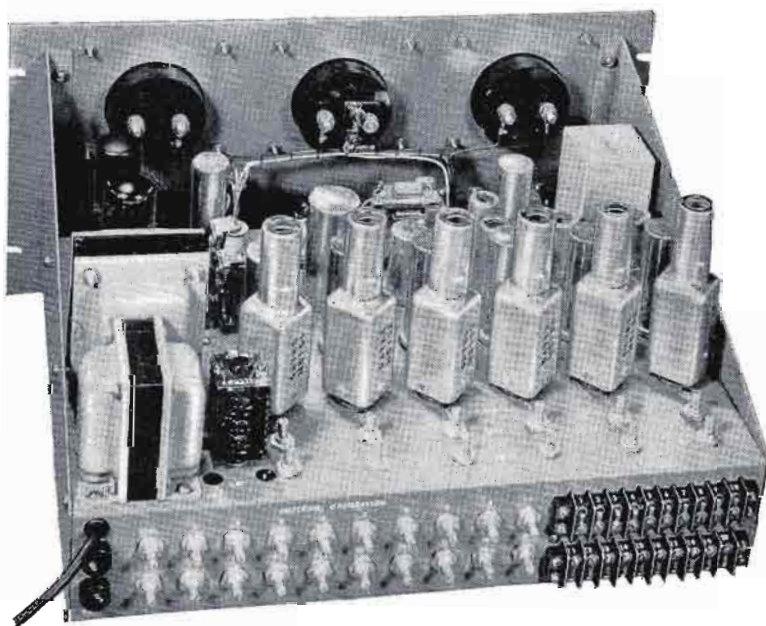

RCM-20 Deluxe Remote Control System

STUDIO UNIT

METERING: Illustrated on Page 67. Has 3 large face 4" meters that will meter up to 19 circuits. Eight metering positions are balanced and terminate externally on both studio and transmitter units. These eight circuits are suggested for frequency monitors, modulation monitors, studio-transmitter phone or any circuit requiring a balanced line. Meters are calibrated in DC amperes, DC kilovolts and RF amperes.

DIALING: Has been eliminated. Positive action non-locking lever keys handle all control functions. A front panel rotor switch accommodates metering functions.

CONTROL FUNCTIONS: Are handled by six phase shift tone oscillators carefully constructed for negligible drift—offering the outstanding feature of being impervious to static or line discharges across the telephone line, which in many systems of the direct type either render the system partially or wholly inoperative.

RELAYS: Stepping relays have gold contacts for absolute circuit make at all times.

POWER SUPPLIES: Are self-contained, including high voltage supply for tone oscillator tubes and selenium supply for stepping relay voltage.

TUBES: 14 type 6AU6, 2 type OA2, one 6L6, 5U4G.

LINES: One pair for metering, one pair for control.

SIZE: 8 3/4" x 19" x 12" deep.

FINISH: Medium gloss gray.

Functional Diagram RCM-20 System.

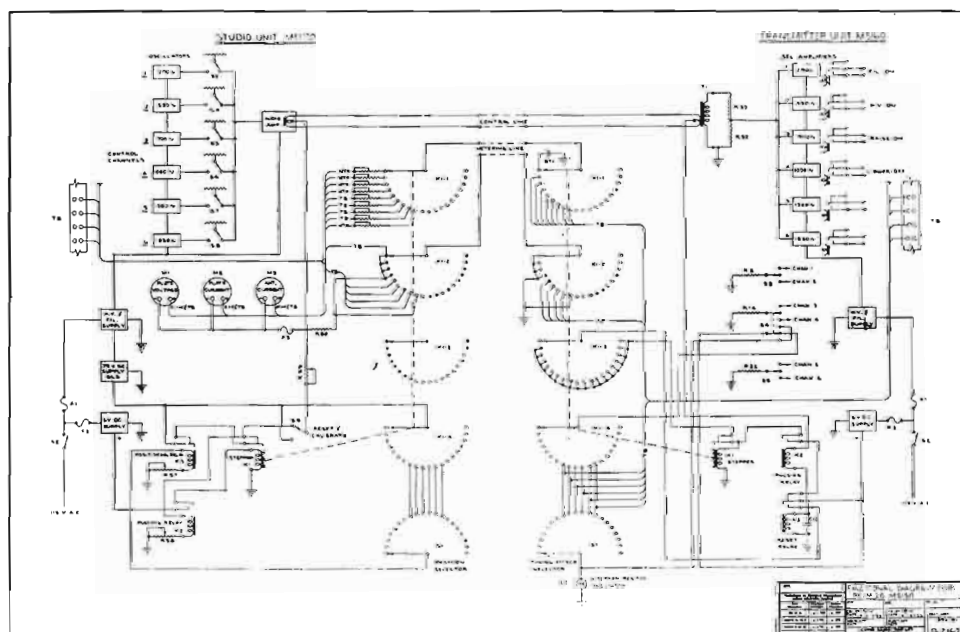

For Unattended Operation Today---Tomorrow

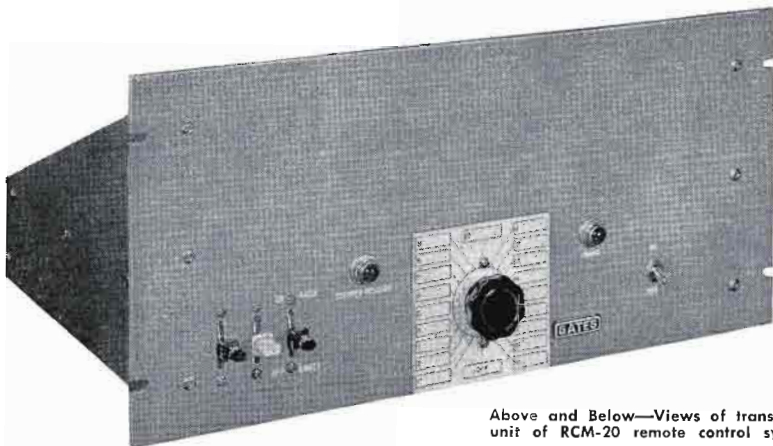

Above and Below—Views of transmitter unit of RCM-20 remote control system.

TRANSMITTER UNIT: Same size and finish as studio unit on Page 68. Has complete local control facilities so operation may be from transmitter either for testing, or when attended such as nighttime directional operation. Six selective amplifiers operate in conjunction with the tone oscillators in the studio unit for the important control functions. These amplifiers are complete with six inbuilt relays to parallel transmitter switches. Switching functions are either holding or momentary, as desired. Two of the control channels are used for motor control, leaving four available for major switching functions.

Up to 38 additional switching functions are possible by use of inexpensive auxiliary relays.

TUBES: Twelve 12AT7, two OA2, one 5U4GA.

POWER: Both studio and transmitter units, 115 volts, 50/60 cycles.

(prices next page)

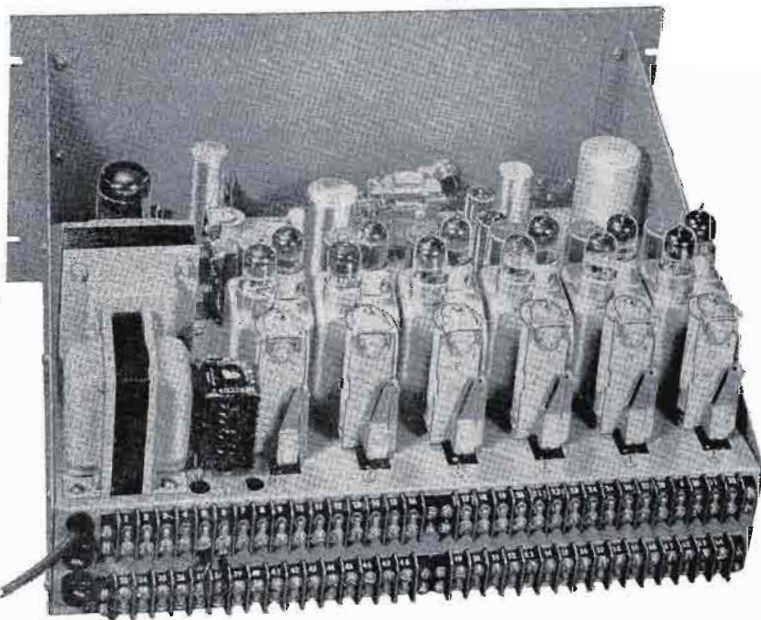

RCM-20 Remote Control System---and Accessories

WHAT IS SUPPLIED: Standard equipment with the M-5150 (RCM-20 System) includes: (a) studio unit complete with tubes, (b) transmitter unit complete with tubes, M-4720 plate current unit listed below, M-4719 plate voltage unit listed below and the inbuilt tower light indicator with sampling transformer.

Model RCM-20 (Factory No. M-5150) Remote Control System \$1425.00

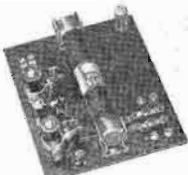

Plate Current Unit
Included with the Gates Remote Control System. Furnishes a sample of plate current which is returned to the studio unit and measured on the directly calibrated plate current meter. The unit is provided with a high voltage fuse for personnel and line protection, and can be used for current ranges of .8 ampere and 3 amperes. Also available as an accessory item to provide metering for additional transmitters.

M-4720 Plate Current Unit \$10.50

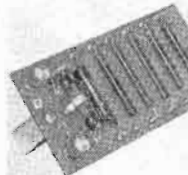
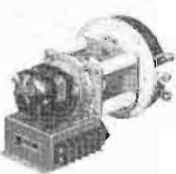

Plate Voltage Unit
Supplied with all Gates Remote Control Systems and furnishes a sample of transmitter plate voltage for return via the metering line to the studio unit. One unit is used with voltages up to and including 6000 volts. For higher voltages, additional units may be connected in series.

Also available as an accessory item for metering additional stages or transmitters.

M-4719 Plate Voltage Unit \$13.95

Motor Operated Rheostat



This motor controlled plate rheostat is recommended for regulating the plate voltage in transmitters of 1KW and less. Available in three sizes for 250, 500 and 1000 watt transmitters. Motor is one RPM and operates from 115 volts, 60 cycles.

M-4703A Motor Rheostat for 250 watts \$100.00
M-4703B Motor Rheostat for 500 watts 100.00
M-4703C Motor Rheostat for 1KW 105.00

Tuning Motor Assembly

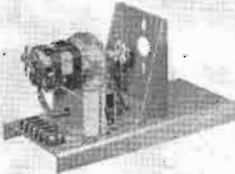

For operating rheostat, variable condenser, or any variable control. Three wire reversible motor 1 RPM. Torque 15 lb. inches.

115 volt, 50/60 cycles.

Mounted on chassis as illustrated.

M-4800 Tuning Motor \$85.00

Tuning Motor

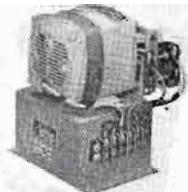

This unit for tuning variable inductor, capacitor or other controls—has inbuilt limit switches. Five wire reversible motor 1 RPM. 20 lb. inches torque. Requires M-4806 relay assembly to right for control. 115 volts, 50/60 cycles.

M-3873B Tuning Motor \$85.00

Relay Assembly

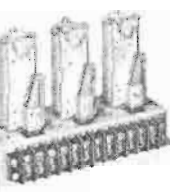

For controlling motors. Usually used where transmitters already incorporate tuning motors. Used with M-3873B to left. As listed below, designed for control of one or two 3-wire motors or one 5-wire motor.

M-4801 for 1 3-wire motor \$22.00
M-4801A for 2 3-wire motors 35.00
M-4806 for 1 5-wire motor 37.50

Overload Relay

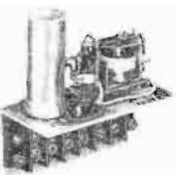

Replaces circuit breakers in current or older models as circuit breakers are usually undependable for remote control. Tripping current adjustable. Inserted in cathode circuit of RF power amplifier. Some engineers prefer an additional unit in modulator circuit.

M-5129 Overload Relay \$17.50

AC Rectifier



Rectifies the AC voltage, either line or filament, at the transmitter and feeds back DC to studio unit for measuring AC by remote control.

M-4825 AC Voltage Unit \$38.50

Antenna Diode Unit



The antenna diode unit is designed to provide remote metering of antenna current. A DC voltage proportional to the antenna current is returned to the studio unit via the metering line and measured on the directly calibrated antenna current meter. The unit pictured is the M-3759 for use with powers of 1KW and under. A similar unit, the M-2765B is available for powers in excess of 1KW. Tube: one type 6H6. Power Requirements: 115 volts, 60 cycles.

M-3759 Diode 1KW or less \$38.90
M-2765B Diode 5KW or more 51.50

FM Output Indicator

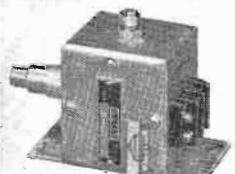

Designed to sample the 51.5 ohm transmission line of an FM transmitter for measuring transmitter output as required by FCC. Provides a DC voltage which is measured on the studio unit metering system.

M-4845 FM Output Indicator..... \$23.00

ACCESSORIES FOR REMOTE CONTROL

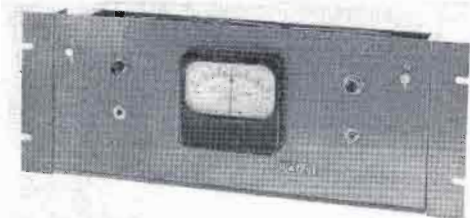

Frequency Monitor Unit

Used for extending Gates or Doolittle frequency monitors where monitor must remain at transmitter. Has 4" frequency indicating meter reading 30-0-30 cycles. Includes resistor pad for sampling voltage. Tubes: 6AW6, 6AQ5, 6AL5, 6X4 and OA2. For 115 volts, 50/60 cycles. Size: 7"x19"x7" deep. Has drop down front panel to service. Finish: medium gloss gray.

M-5270 Frequency monitor extension unit \$195.00

Monitor Extension Meters

Several types available as listed below for extending both frequency and modulation monitors. Meter is appropriate to type of monitor being extended. Mounted on standard 19" rack panel 5 1/4" high.

- M-5210 for extending Gates MO-2639 modulation monitor \$50.00
- M-5206 for GR1931A or RCA WM43A monitors 50.00
- M-5208 for GR1181A or RCA WF48A monitors 50.00
- M-5207 for RCA 66 Series monitors 50.00
- M-5209 for RCA 311A monitor 50.00

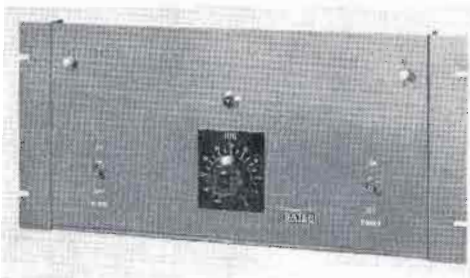

RF Amplifier M-5144

(For Monitors in Studio)

Preferred method is to have frequency and modulation monitors at the studios where the operator may view the operation at all times. This unit picks up the off air signal, furnishes both modulated and unmodulated signal to Gates, GR or RCA frequency and modulation monitors. Includes audio output and carrier failure relay to operate external alarm. Power supply is self-contained. Drop down front panel for servicing all inner components. Supplied with complete antenna kit.

Tubes: (4) 6AU6, (1) 6BA6, 6L6, 5V4G, 6080, OD3.
Power: 115 volts, 50/60 cycles, 95 watts.
Size: 8 1/4"x19"x8" deep. Finish: gray.

Model M-5144 RF Amplifier with tubes \$250.00

FM Monitor Amplifier

Operates with any approved FM frequency/modulation monitor where the signal is taken off the air and monitor is at studio. Amplifier supplied fixed tuned to your frequency. Power supply is not supplied. Requires 300 volts DC at 100 MA and 6.3 volts AC at 3 amperes.

Size: 7"x19"x8" deep. Finish: medium gloss gray.
Tubes: 6AK5, 6BA6, 6AH6, 2E26, OA2.

M-4791 FM Monitor Amplifier with tubes \$235.00

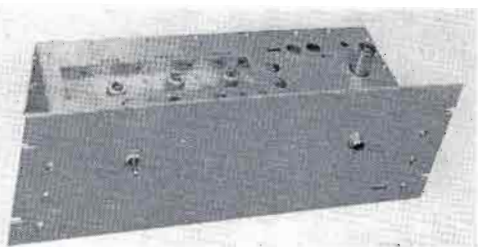

Remote Meter Panel

Broadcasters having studio and transmitter together often have the transmitter located some distance from the control board, making meter reading difficult. This unit consists of 3 meters exactly as shown on the RCM-20 studio unit on Page 67, along with M-4719 and M-4720 metering kits on Page 70. To read antenna current, the M-3759 or M-2765B diode should be used. Meters include: DC amperes, DC volts, RF amperes. By mounting this meter panel near the studio control board, the major meters of the transmitter may be observed and logged. On 5 1/4"x19" rack panel.

M-5252 Metering Panel \$95.00

Special Equipment for Remote Control

Gates has made every effort to provide a most complete line of equipment for unattended operation. It is recognized that unusual situations of multiple transmitters or directional requirements* may demand special accessories. Gates engineers will happily work with our customers on any special application.

*Directional operation of radio stations by remote control not authorized in the U. S. at time of publication.

GATES

PHASE MONITOR --- FIELD METER

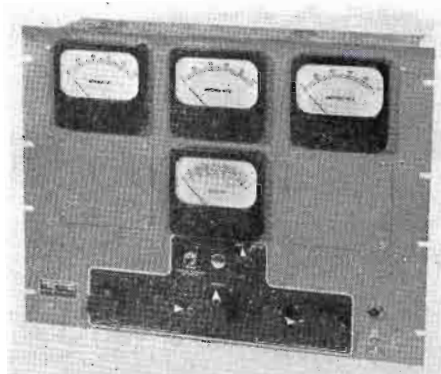

Model 108E three-tower monitor.

Phase Monitor

Recognized as the finest phase meter built today. Available in standard models up to 5 towers. Special designs above 4 towers readily available. The Clarke 108 phase meter comes with remote antenna current meters and is unaffected by modulation. Operation has been simplified. Two selector switches are set to elements to be compared and the outputs of the amplifiers are adjusted to a red line on the meters. By a flip of a switch, the phase difference is indicated.

Specifications

FREQUENCY RANGE: 100 Kc to 2000 Kc (as ordered).
PHASE ANGLE RANGE: 0-360 degrees.
MONITORING ACCURACY: 1 degree.
RESOLUTION: $\frac{1}{2}$ degree.
RF INPUT IMPEDANCE: 50 or 70 ohms (as ordered).
RF VOLTAGE RANGE: 1-7 volts.
SIZE: 14" high, 19" wide, 7" deep.
POWER: 115 volts, 50/60 cycles, 80 watts.
TUBES: (2) 6AU6, (2) OB3, (3) 6AL5, (1) 5Y3.

Ordering Data

Model 108D two towers \$550.00
Model 108E three towers 575.00
Model 108F four towers 600.00
Model 108 (more than four towers) ... on request

WHEN ORDERING: State carrier frequency, remote meter ranges, type of sampling line or impedance and carrier power.



Model 108D two-tower phase monitor.

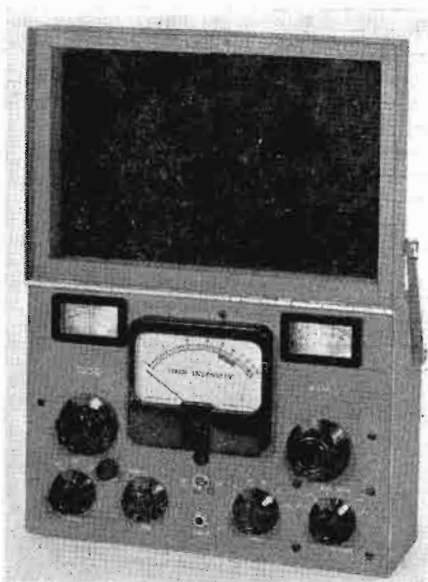

Field Intensity Meter

The Clarke 120-D (formerly WX-2D) field meter is for measurement of radio signal intensity in the broadcast band between 540-1600 Kc. Sensitivity from 10 microvolts to 10 volts per meter, makes it equally effective for interference studies and close in measurements of high power directional arrays. — For measurements of any directional system or signal intensity, this test instrument is indispensable. — The 120-D meter is battery operated, weighs only 12½ lbs. and is direct reading.

Specifications

FREQUENCY RANGE: 540-1600 Kc.
FIELD INTENSITY RANGE: 10 microvolts to 10 volts per meter.
ACCURACY OF ATTENUATORS: 2%.
OUTPUT INDICATORS: Panel meter, direct reading, with logarithmic scale graduated 1 to 10 and HAVING NO ZERO MARK (needle is OFF SCALE when meter is not energized). Provision for using recorder, and headphones.
ANTENNA: Shielded unbalanced loop.
BATTERIES: Five 1½ volt A. Two 67½ volt B.
BATTERY LIFE: Approximately 500 indications.
TUBES: (4) 1T4, (2) 1R5.
SIZE: 9" high, 13" wide, 5¾" deep (closed).
WEIGHT: 12½ lbs.

Model 120D Field Meter \$790.00
(less batteries)

NOTE: As standard batteries are employed, it is recommended that batteries be procured locally as needed.

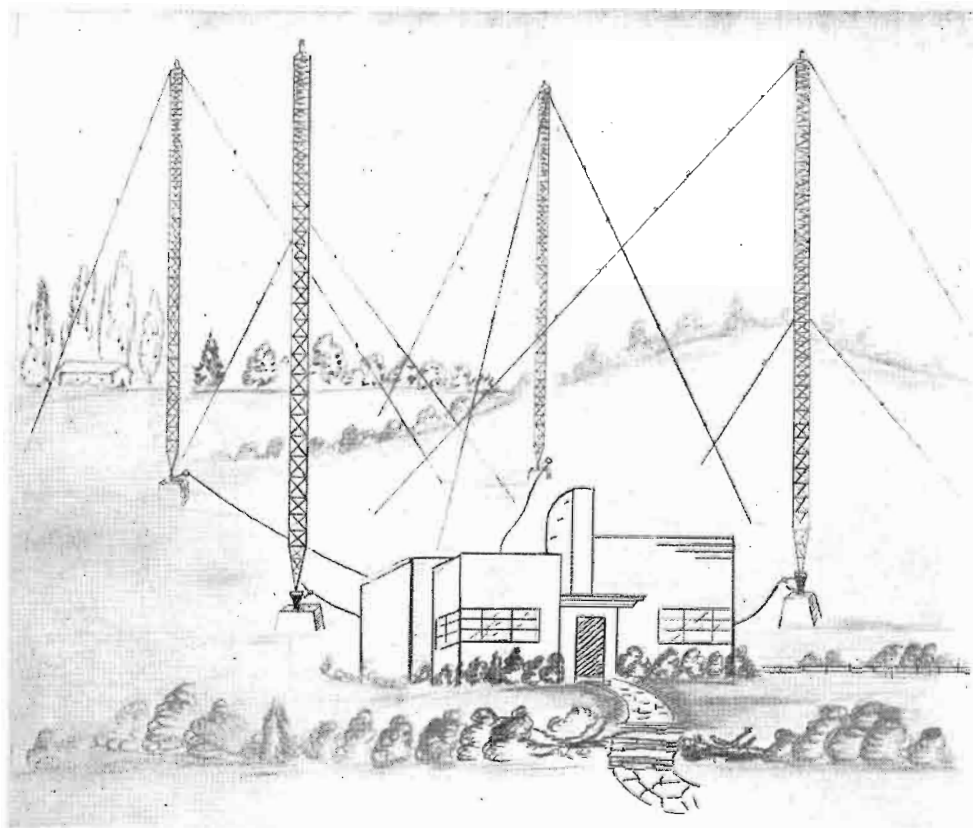

Directional Phasing Equipment

Importance of good design and quality manufacturing is best demonstrated in directional phasing equipment. Here, stability of pattern and reliability of components are most important. Even more important is the knowledge of proper physical layout to prevent element interaction, component design for highest efficiency, proper L/C ratios and minimum heating. Even cabinet design, where in many instances the choice between ferrous or non-ferrous metals and plating, has much to do with final performance.

Gates phasing equipment has for years been the choice of broadcasters and has held a fine reputation in meeting the exact specifications of consulting engineers. — Minimum tune-up time and minimum maintenance makes Gates directional phasing equipment less expensive, though nothing is spared in the design cost.

(Continued next page)

PHASOR --- 20KW TWO TOWERS

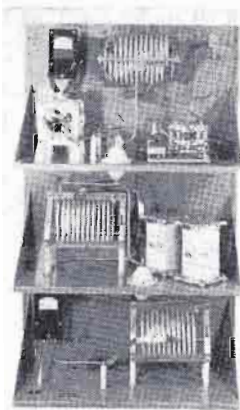
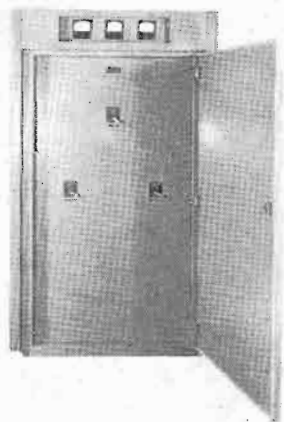
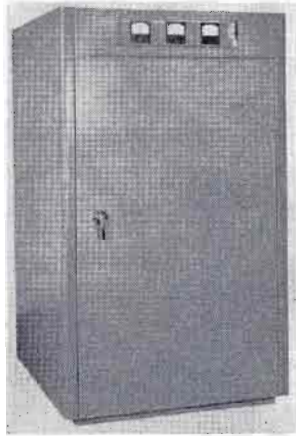
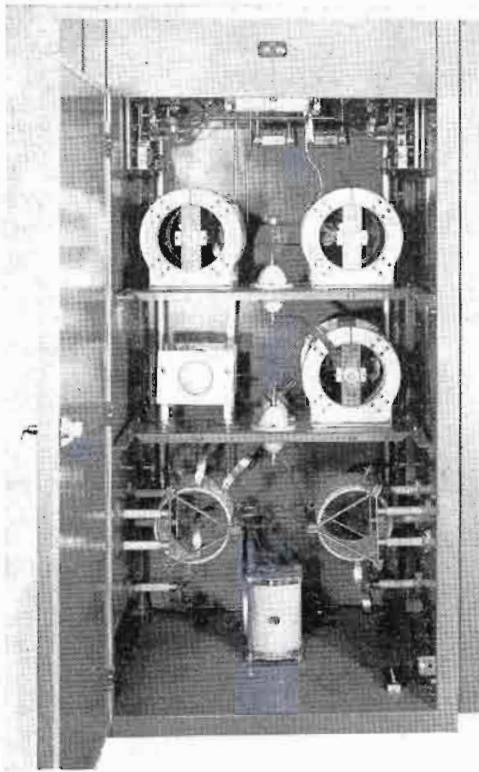

This phasor, like nearly all directional phasing equipment, is manufactured to the electrical specifications of the customer's consultant. Power rating is 20KW directional night, non-directional day. — The cabinet, in this case, matches Gates transmitters, 5KW and higher in power, and is approximately 42" wide, 78" high and 48" deep, with full size front and back doors. — Typical shelf-type antenna termination unit is illustrated to the left. Here illustrated, Gates believes, is truly fine phasing equipment, the keynote being construction with large rugged components.

For reference, this is cabinet style A with shelf-type antenna coupler of indoor type.

PHASOR --- 5KW FOUR TOWERS

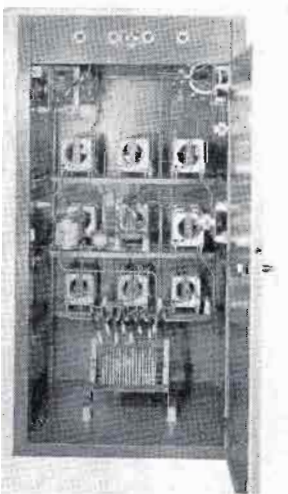
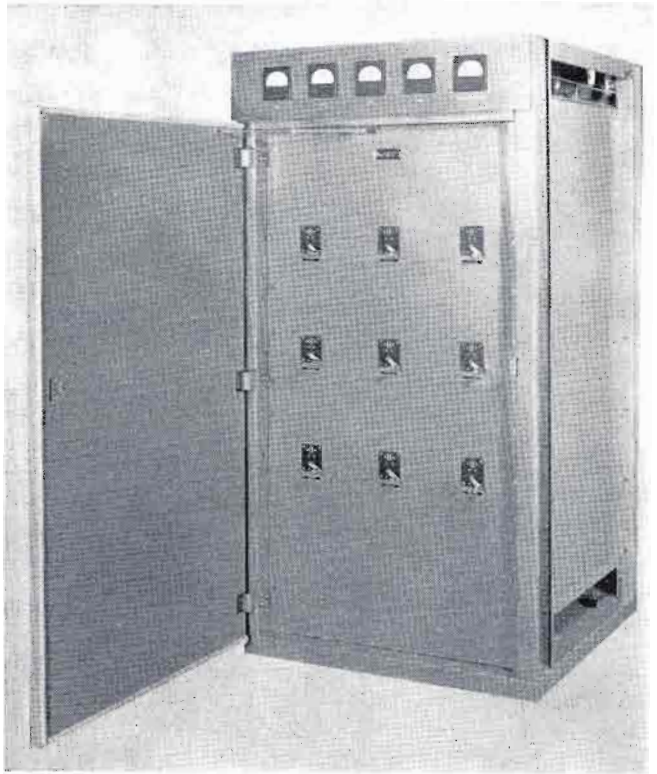
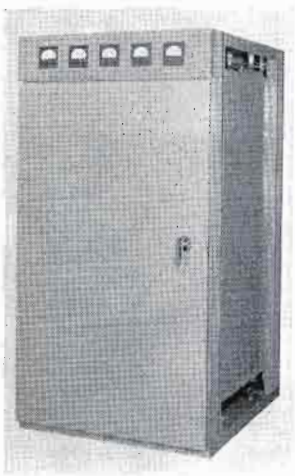

Another typical phasing equipment, in this instance for 5000 watts power, four towers, one pattern. In most instances the same general design would be employed, other than larger component sizes, for 10KW. The engineer will note that nine of the edgewise coils in this phasing equipment are continuously variable and tuned from the front panel by means of counter type dials which may be logged to one-tenth turn.

For reference, this is cabinet style A with end bell removed for direct attachment to Gates transmitters above 5KW. Antenna coupler illustrated is of the shelf indoor type.

PHASOR --- 5KW Two Towers, Two Patterns

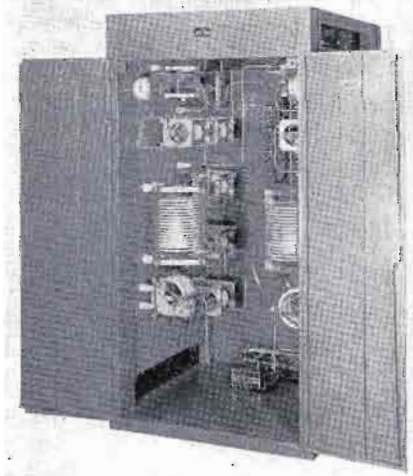
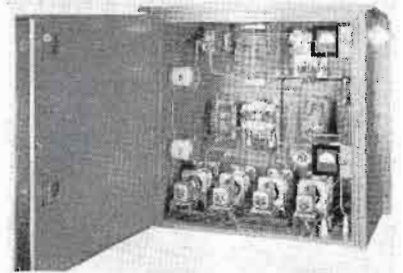
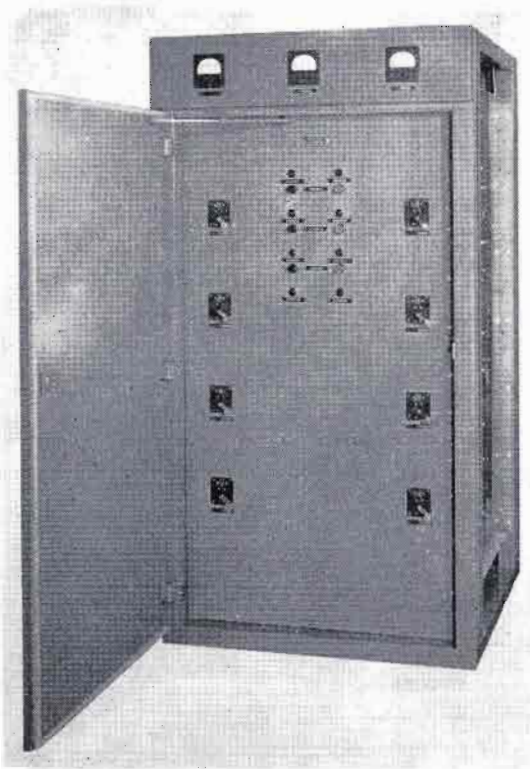

It is obvious in viewing this husky phasor, the consultant's specifications developed unusually heavy currents in certain elements of the design for a 2-tower, 2-pattern, 5KW phasor. This is an excellent illustration of Gates design engineers working together with the consulting engineering profession to produce a stable and reliable installation. Here eight coils continuously variable are tuned via counter dials from the cabinet front. No variable air capacitors are used anywhere because of flash-over possibility.

For reference, this is cabinet style A, specifically designed to match Gates transmitters 5KW and larger but conservative design matches any mode of installation. Antenna coupler above right is in weatherproof double-door housing and illustrates motor tuning often employed for more complicated phasing equipments of extremely close tolerance.

PHASOR --- 5KW Three Towers, Two Patterns

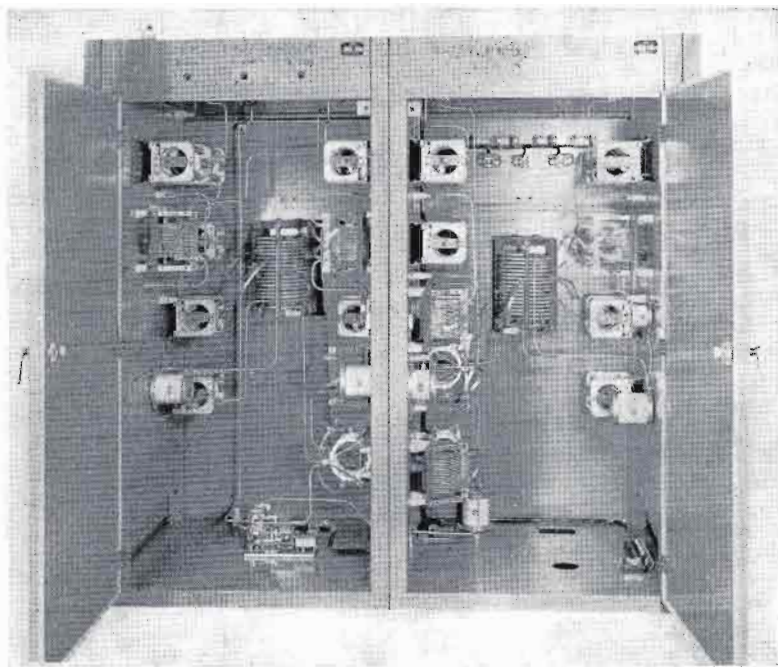

In certain designs it is often advisable to entirely segregate the elements for daytime and nighttime patterns. This two-pattern phasor, constructed in two enclosures, was for a moderately tight pattern. Left rear above are the nighttime components, and right portion, daytime components. Two style A cabinets are joined together. Total phasor width approximately 85".

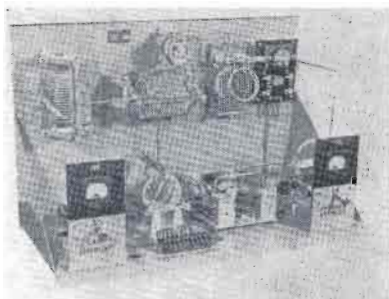
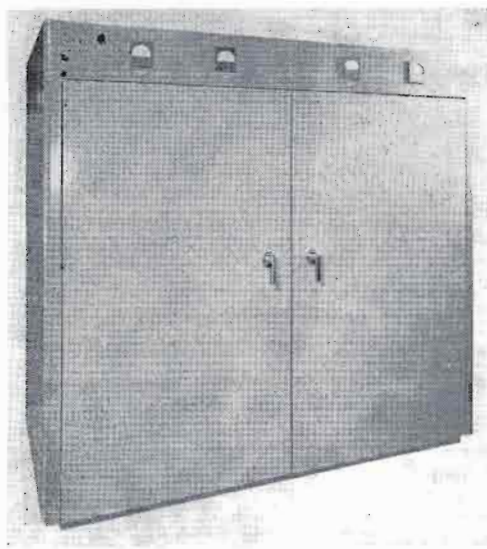

Indoor shelf-type antenna coupling units are often employed, mounted inside the so-called "doghouse" adjoining the antenna. There is no need for weatherproofing and all components are easily reached for adjustments.

2 AND 3 TOWER PHASING EQUIPMENT

1KW Three Towers

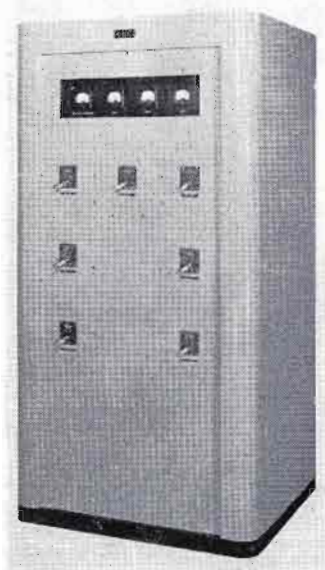

Gates phasor construction has received a great deal of favorable acclaim because of the generous use of continuously variable coils. This adds greatly to the ease of tune-up as well as wider latitudes to take care of local conditions sometimes not originally known at time of phasor computation. Here again there are 7 tuned coils from the front of the phasing cabinet. — Coils used in all Gates phasors are manufactured in the Gates plant, of heavy silver-plated ribbon, mycalex insulated — all variable coils have rigid cast end bells.

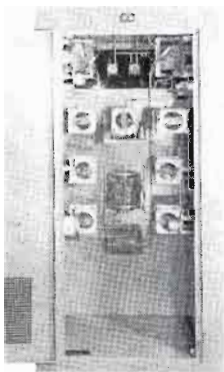

For reference, this is cabinet style B and stands 40" wide, 78" high and 33" deep.

Two-Tower Phasor

Designed for 1KW operation, this phasing equipment requires a minimum of floor space and offers all of the excellence that will be found in the larger, more complicated phasing equipments. Gates engineers have made phasing equipments for almost every conceivable pattern and multiple tower installation found in the United States. — Whether 500 watts of 100KW, Gates engineering designs not only rigidly follow consultant's specifications but add to their conservative design by always providing components way larger than normal operating conditions require. — This two-tower phasor is in cabinet style C, standing 23½" wide, 78" high and 20½" deep.

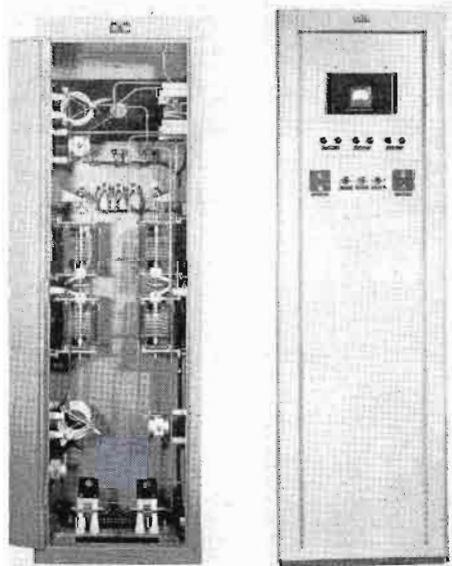
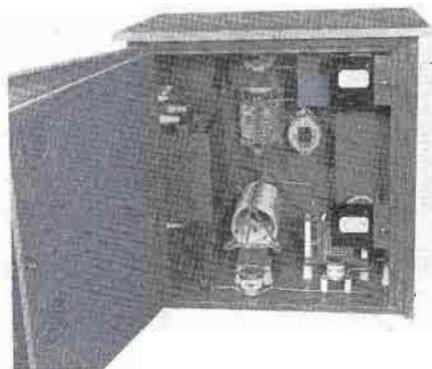

Weatherproof Coupler

This weatherproof coupler does not require a dog-house and mounts adjacent to the tower either on posts or platform, and has double front door so that meters may be observed without opening inner door such as under storm conditions. Top of cabinet is sloped and this model is available in both ferrous and non-ferrous metals, depending upon engineering requirements.

ANTENNA COUPLER --- 1250 Watts and Lower

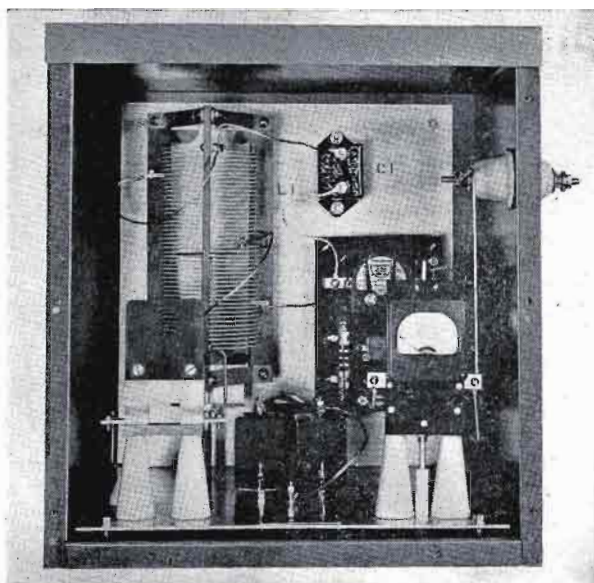

A fully weatherproof coupler for series feed antennas to handle 1250 watts or less and at 100% modulation. Plug-in meter supplied, which may be inserted in either line or antenna circuit. Meter shorting switch is provided in antenna circuit to eliminate damage to meter during electrical disturbances. Antenna meter may be observed through glass porthole. Coil is silver plated, edgewise wound mycalex insulated, having generous inductance for arrangement in a full Tee network along with the fixed mica capacitors supplied. Extra room is provided in the cabinet for either diode or thermocouple type remote metering kits as listed on Page 82.

SPECIFICATIONS

- CARRIER POWER:** 1250 watts or less.
INPUT IMPEDANCE: 50 to 360 ohms, concentric or open line.
ANTENNA RESISTANCE: 10 to 1000 ohms.
ANTENNA REACTANCE: Plus J 600 to minus J 300 ohms from 540 to 1000 Kc.
Plus J 600 to minus J 500 ohms above 1000 Kc.
CIRCUIT: Tee network.
LIGHTNING PROTECTION: Meter shorting switch.
METERING: Plug-in 3" meter normally located as antenna meter but may be used as line meter for tune-up. Plug-in shorting bar provided for unused meter jack.
REMOTE METERING: Provision for either thermocouple or diode type as ordered.
SHIPPING WEIGHT: 98 lbs.
SIZE: 20" high, 20 1/4" wide, 18 3/4" deep.

Model 44 Antenna Coupler, with antenna meter \$230.00

NOTE: Kindly state transmission line impedance, frequency, tower height and tower measurements if known.

GATES

79

ANTENNA COUPLERS --- 1250 Watts or Lower

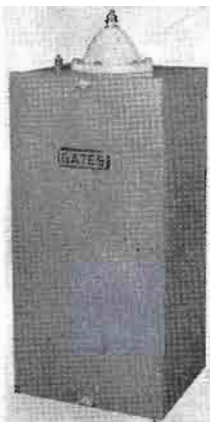

Series and Shunt Feed Couplers

Model M-5178: Series feed, provides all coil and capacitance to provide full Tee network. Constructed in non-weatherproof steel cabinet, front removable. Size: 21" high, 10" wide, 9" deep. Matches RF input of 50 or 70 ohms. Output 10-600 ohms. In this model metering is external to the coupler, often desirable in unattended operation. For all powers 100% modulated up to 1250 watts carrier.

Model M-5178 Antenna Coupler \$125.00

Model M-5179: Shunt feed coupler of coil and capacitor combination to tune out the reactance in shunt fed antenna coupling. Same size as M-5178 above. Rating up to 1250 watts carrier 100% modulated.

Model M-5179 Antenna Coupler \$125.00

NOTE: Please state frequency, tower height and tower measurements if known.

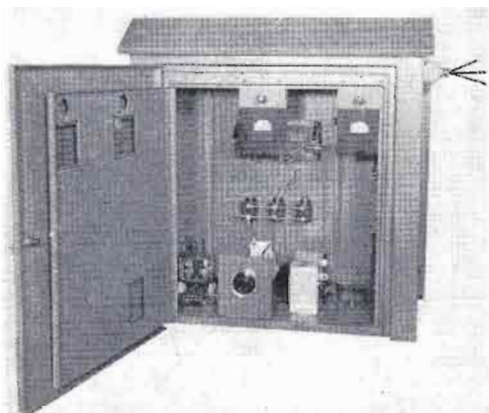
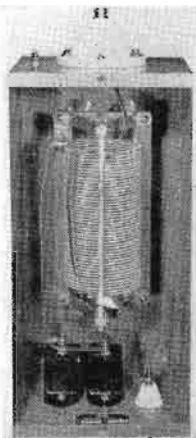

Complete Tower Termination Unit

Includes all necessary equipment to couple tower to transmission line, lights and diode type remote metering. Rating up to 1250 watts modulated. Built in weatherproof double door doghouse 36" wide, 39" high and 30" deep. Both line and antenna meters have separate meter shunting switches. Diode type remote meter includes a third meter for installation at the transmitter. 3-section solenoid type tower light choke with capacitors is included. Antenna coupler includes a wide range in inductance and capacitance.

SPECIFICATIONS

FREQUENCY: 540-1700 Kc, as ordered.
INPUT IMPEDANCE: 45-360 ohms, as ordered.
ANTENNA RESISTANCE: 25-1000 ohms.
REACTANCE: Plus J 600 ohms to minus J 300 ohms, 540-1000 Kc.
 Plus J 600 ohms to minus J 500 ohms, 1000-1700 Kc.
CIRCUIT: Full Tee network.

Model 47A Antenna Terminating Unit...\$585.00

Phase Sampling Loops

M-3283: This model especially applicable where high current ratios are to be sampled. May be rotated so that phase monitor amplitude values are nearly equal. Electrostatically shielded and insulated from tower. May be used with or without isolation coil at base of tower. Coil is single loop of 7/8" coaxial cable, heavily insulated from base frame. Matches either 50 or 70 ohm line. Size: 45" wide, 60" high.

M-3283 Sampling Loop \$95.00

M-3389: Very similar to M-3283 in size and rotating capabilities. Consists of a loop of RG/8U coaxial cable within a loop of 7/8" copper tubing. Provides unusually fine shielding and eliminates external coupling in preventing the flow of undesirable current in the outer conductor. Size: 63" high, 40" wide. For 50 ohm line only.

M-3389 Sampling Loop \$95.00

M-3723: A simple non-adjustable loop and not insulated from tower. Usually used in less complicated directional where currents in towers are nearly equal and high enough to cover stray effects. Matches 50 or 70 ohms and must be used with isolation coil. Made of aluminum angle. Provided with connector for RG/8U line. Size: 60" high, 40" wide.

M-3723 Sampling Loop \$35.00

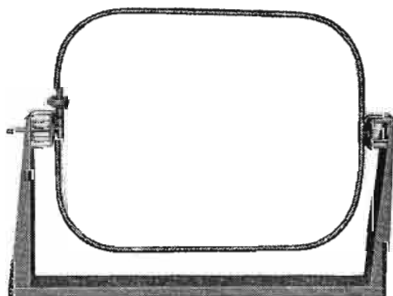

M-3283 and M-3389 Loops

Ordering Sampling Loops

Unless for replacement purposes, it is always suggested that sampling loops be ordered on recommendation of the customer's consulting engineer. As the loop and its associated transmission line, and in some instances the isolation coil, are all part of the overall computations, the slight delay in checking with the consultant will often save time and expense.

5-10KW ANTENNA COUPLING UNITS

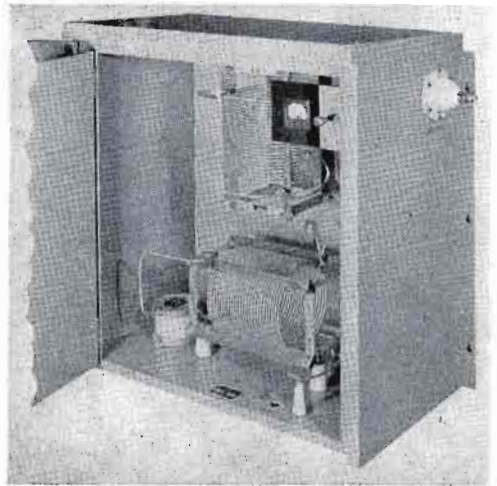
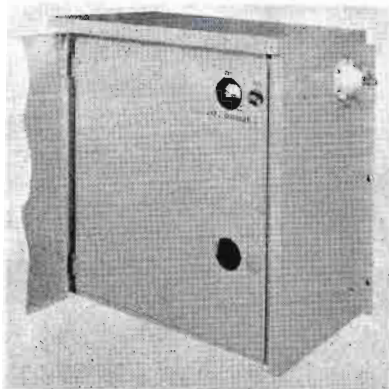

These two nearly identical models differ only in component size for 5 and 10KW power ratings. Housed in an aluminum cabinet with double front doors. Size: 38" high, 37" wide, and 21 1/2" deep. Antenna meter may be observed and meter shorting switch operated with the inner door closed. Coils are silver plated and micalex insulated. Capacitors have generous voltage and current safety factor. All ratings are 100% modulated.

Tuning unit may be mounted by metal flanges at each back side. Usually two wooden poles, set in the ground, are used for mounting. A large lead in bowl is provided for antenna connection. The use of non-ferrous metal in the tuning house will prevent component heating under certain conditions.

SPECIFICATIONS

FREQUENCY RANGE: 540-1700 Kc, as ordered.
INPUT IMPEDANCE: 45-360 ohms, as ordered.
ANTENNA RESISTANCE: 20-1000 ohms.
REACTANCE: +J500 to -J500.
WEIGHT: Packed, 315 lbs. (export); 200 lbs. (domestic).
Unpacked, 136 lbs. Cubage, 24.

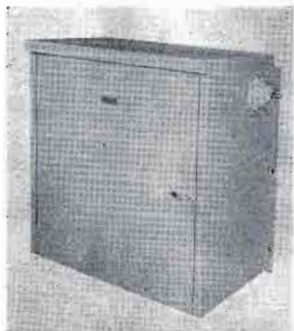

M-5309A Coupling Unit for 5KW\$595.00

M-5309B Coupling Unit for 10KW 875.00

NOTE: When ordering, state carrier frequency, transmission line impedance, tower height and tower resistance measurements if known.

GATES

TOWER CHOKES --- ISOLATION COIL

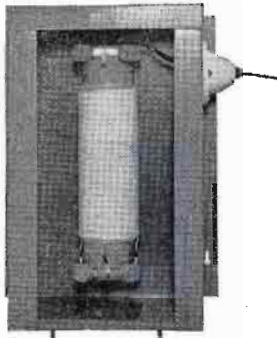

Fig. A

Solenoid Tower Chokes

Most popular of all tower light isolation chokes. Available in 2 or 3 section and in open type, illustrated to right, or weatherproof type, illustrated to left. Wound on XX heavy bakelite tubing with mica by-pass condensers on each circuit end. Inductance 350 uh. 3" stand-off insulators are part of coil. Size: choke only, 18 1/2" long, 5" diameter, 7 1/2" from bottom of insulator to top of coil. Weatherproof type, 24" high, 17 3/4" wide, 10 1/4" deep. Illustration to left shows front cover of weatherproof unit removed for photographing.

M-3935, 2-section, Fig. B	\$ 45.50
M-3936, 3-section, Fig. B	65.00
M-3937, 2-section, Fig. A	85.75
M-3938, 3-section, Fig. A	105.00



Fig. B

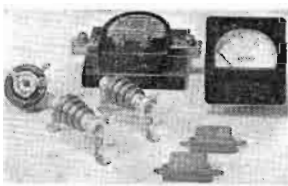

Fig. A



Fig. B

Remote Meter Kits

Thermocouple Type: Fig. A above. Includes 3" square case meter, thermocouple, adjusting rheostat, chokes and capacitors. May be used up to 1000' of 2C No. 18 or larger line for remote metering between tuning house and transmitter.

M-3383 complete (meter range 0-3 RFA)	\$62.00
M-3133 complete (meter range 0-5 RFA)	62.00
M-3386 complete (meter range 0-10 RFA)	62.00

Diode Type: Fig. B above. Inductively connects to antenna lead for excellent protection against electrical disturbances. Uses 6H6 tube. Operates from 115 volt tower light circuit. May be used with 2C line up to 5000 feet. Available with or without meter. Standard 1 MA meter is employed. Ratings are 100% modulated.

M-3294 1KW or less, 0-3 RF scale	\$55.85
M-3294B 1KW or less, 0-5 RF scale	55.85
M-3294B 1KW or less, 0-10 RF scale	55.85
M-5334 5/10KW, 0-5 RF scale	68.45
M-5335 5/10KW, 0-10 RF scale	68.45
M-3759 Diode less meter, 1KW or less	38.90
M-2765B Diode less meter, 5/10KW	51.50

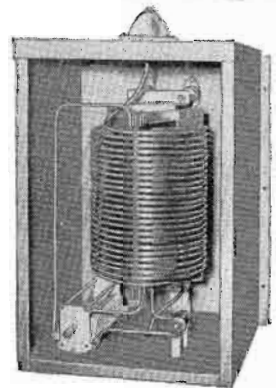

Isolation Coil

Used to isolate a phase sampling loop across base insulator of tower. A parallel resonant circuit with coil of 3/8" coaxial cable micalax insulated. Inductance 85 uh with 150 mmfd tuning capacitor. Available in weatherproof model illustrated above (front cover removed) and coil only for mounting inside tuning house. Size (weatherproof model): 20" wide, 32 1/2" high, 18 1/2" deep. State carrier frequency and power when ordering.

M-3073 Weatherproof Isolation Unit	\$225.00
M-4561 Coil only, less cabinet	175.00

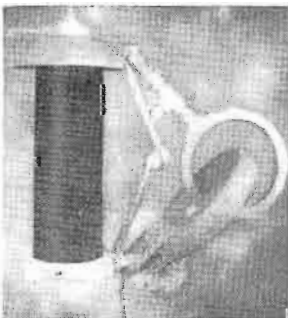

Austin Ring Type Tower Choke

Ring type tower choke is a transformer with clear air space between primary and secondary and resultant zero RF leakage. Independent of frequency. All models are for 115/230 volt primary and 115 volt secondary. Base insulator in photo for illustration purposes only.

Type	Capacity KVA	Mfg. Style	Net Wt. lbs.	Attachm'ts	Price
A-2100	1—1.75	Side Bracket	81	none	\$288.00
A-2101	1—1.75	Side Bracket	85	Lt. gap	298.00
A-2102	1—1.75	Pedestal	82	none	288.00
A-2103	1—1.75	Pedestal	86	Lt. gap	298.00
A-1970	2—3	Side Bracket	188	none	321.00
A-1971	2—3	Side Bracket	201	Lt. gap	337.00
A-1972	2—3	Pedestal	182	none	321.00
A-1973	2—3	Pedestal	200	Lt. gap	336.00

PROOF OF PERFORMANCE EQUIPMENT

Calibrated Audio Oscillator

Measures audio frequencies between 30-30,000 cycles. No 0 reset or line calibration required. Self-contained power supply. Housed in attractive steel cabinet with carrying handle. Size: 13 3/4" x 7 1/4" x 9 1/2".

SPECIFICATIONS

VOLTAGE OUTPUT: 10 volts into 500 ohms.
 WAVE FORM: RMS harmonics at 3 volts on 500 ohm load, less than 1% all frequencies 50-15,000 cps.
 RESPONSE: ± 1 db or better 30-15,000 cycles.
 STABILITY: 1% or better.
 CALIBRATION: $\pm 3\%$ of scale reading.
 POWER: 115 volts, 50/60 cycles.

Model 200 B & W Audio Oscillator \$138.00



Noise and Distortion Meter

For measurements of noise and distortion — both audio equipment and radio transmitters. Variable frequency selective filter provides single frequency suppression circuit of 30-15,000 cycle range. Size: 13 3/4" x 7 1/4" x 9 1/2". In attractive metal cabinet and beautifully styled.

SPECIFICATIONS

FREQUENCY RANGE: (a) Distortion meter 30-15,000 cycles measuring harmonics to 45,000 cycles.
 (b) Voltmeter and db meter 30-45,000 cycles.
 SENSITIVITY: (a) Noise and distortion, 0.3 volts.
 (b) Voltmeter, full scale readings, 0.3, 0.1, .03, .01 and .003 volts.
 CALIBRATION: For distortion ± 0.5 db. For voltage measurements $\pm 5\%$ of full scale at 1000 cps.

Model 400 B & W Distortion Meter \$168.00



Gain Measuring Set

Ideal for use with above oscillator and distortion meter but may be used with any similar equipment. Consists of VU meter and associated switches to accommodate all usable ranges for measuring. Attenuation circuit includes a 10 step, 2 db per step, variable attenuator balanced ladder type, and three fixed plug-in pads. Pads are used for attenuation and impedance matching. Two pads have 40 db attenuation at 600/600 ohms and one has 20 db at 600/250 ohms, all balanced H. Additional pads of any loss or impedance obtainable on special order.

INPUT IMPEDANCE: 600 ohms balanced.
 OUTPUT IMPEDANCE: 30 to 600 ohms balanced.
 OUTPUT LEVEL: Variable from -21 dbm to -36 dbm.

Model M-3625 Gain Measuring Set \$125.00
 Extra plug-in pads, any impedance or loss 5.00

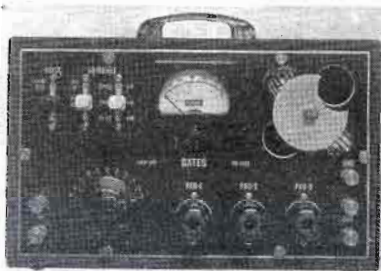

RESPONSE: $\pm 1/2$ db 30-15,000 cycles.
 DISTORTION AND NOISE: Negligible.

M-3626 Rectifier/Pickup Coil

Used with AM transmitters in conjunction with Model 400 distortion meter, listed above. Picks up RF from tank circuit for measuring noise and distortion. Includes RF pickup coil, 15-foot section of coaxial cable, and germanium diode. Complete RF filtering guarantees pure audio output which is free from RF disturbances.

FREQUENCY RANGE: 550-20,000 Kc.
 RESPONSE: ± 1 db 30-15,000 cycles.

OUTPUT IMPEDANCE: 600 ohms.
 OUTPUT LEVEL: +12 dbm.

Model M-3626 Rectifier/Pickup Coil \$37.50

Complete Proof of Performance Package

Consists of Type 200 Oscillator, Type 400 Noise and Distortion Meter, M-3625 Gain Measuring Set, and M-3626 Rectifier Unit with RF pickup coil and transmission line cable. Complete package provides all facilities for proof of performance of both audio frequency and AM radio transmitters. Provided with this package is a complete instruction book covering not only instructions for operating the equipment but suggested methods in making proof of performance measurements that are accurate and reliable.

Model SA-131 Complete Proof of Performance Package \$468.50

Summary

FCC Regulations on Proof of Performance

Proof of performance is not only an FCC regulation but likewise a highly desirable portion of the technical operation of any broadcasting plant. The Gates engineering department has carefully read the regulations pertaining to proof of performance and offers the following condensed summary of FCC regulations. It is recommended that the technical supervisor read the entire regulation at his convenience.

1. Since 1950, all standard AM stations as well as FM broadcasting stations have been required to make a complete proof of performance on all phases of the broadcasting plant.
2. This proof of performance pertains to frequency response, noise and distortion. Measurements obtained, of course, must meet FCC individual and overall requirements under the Standards of Good Engineering Practice as issued by the Federal Communications Commission.
3. Proof of performance readings must be taken at least once each year and preferably the last four months of each calendar year, or coincidental with the time that any license renewal is requested.
4. Information as to proof of performance is not posted with the FCC unless specifically requested by license renewal forms carrying a direct question asking if measurements have been made and if they prove that the equipment is operating in accordance with the Standards of Good Engineering Practice as set forth by the Federal Communications Commission.
5. Measurements must be recorded as a written report and kept at the radio transmitter building for examination by the field inspection service of the Federal Communications Commission at any time requested.
6. The FCC does not specifically approve or disapprove any particular equipment for making proof of performance tests. There must be every evidence that the equipment being used for these tests is satisfactory in all respects and is functioning properly.
7. There is no requirement that broadcasting stations own the equipment for proof of performance tests. This means that others who own the equipment such as the consulting engineering profession may be engaged to do this work.

The Importance of Proof Of Performance

The importance of proof of performance does not lie in a Federal regulation even though this regulation exists but in the keeping of the broadcast transmitting plant in top efficiency from the standpoint of signal quality at the point of the listeners' receivers. Recent trends in many areas have been for broadcasting stations to feature music of all kinds and, of course, music without wide frequency response, low distortion and inaudible noise has much to be desired. — Proof of performance equipment for the radio broadcasting station may be likened to the airliner that is fully inspected at the end of the run. In this case it is a safety precaution. For proof of performance it provides a regular periodic inspection of the operating performance of the equipment, keeping it in topflight condition.

No radio broadcasting station, large or small, should be without a regular and established proof of performance time on the calendar. We suggest that it is one day each month. — The SA-131 complete proof of performance package listed on the preceding page is a modest cost, highly efficient test package for every necessary function in proving performance.

for *Audio Control*

Speech input equipment listed in the following section of this catalog offers the industry a wide selection of modern, up-to-date and progressive equipment.

Gates engineers are recognized around the world as designers of audio equipment that combines the best in performance with a new approach to mechanical construction, providing greater ease in servicing and more value for each dollar invested.

The search for better ways is an unending program. The many new modern speech input equipments listed herein, when examined, will quickly amplify this statement. Whether the needs are for the world's largest radio studios (such as major requirements Gates was privileged to supply for the United States Information Service), or the smallest audio instrument—if it has the Gates name plate, it is a product with thoughtful, accurate and quality design.

(please turn the page)



GATES

SPECIAL AUDIO EQUIPMENT

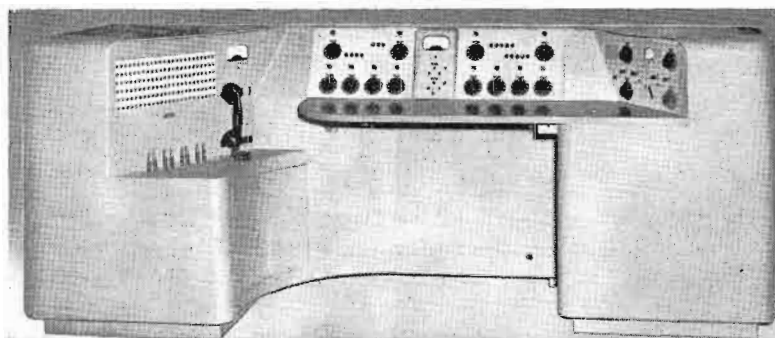
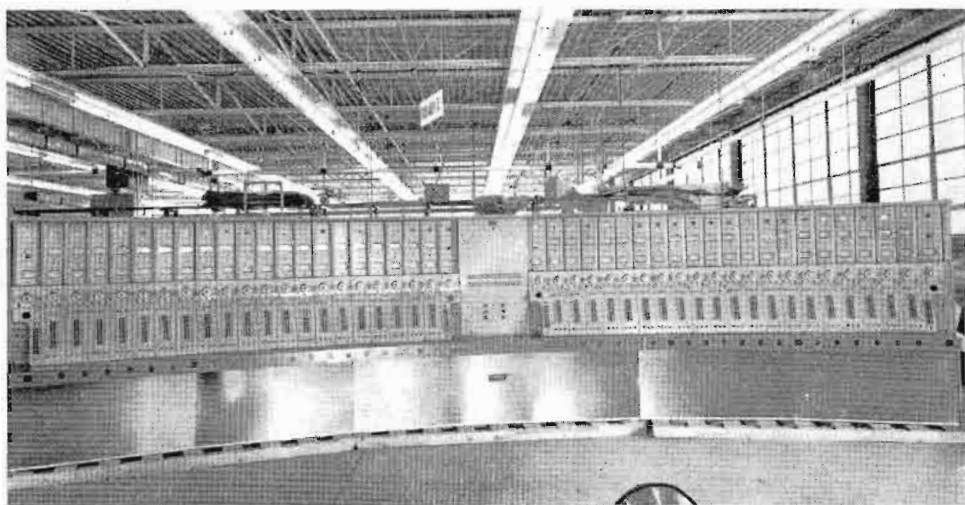

U. S. I. A. Studios in Washington, formerly Voice of America, are often referred to as the world's largest. Top picture may also be the world's largest master control console, 26' wide. 16 sub-master consoles (center) are employed. Bottom illustrates another giant size master control. Major U. S. I. A. equipment was manufactured by Gates, including these units illustrated.

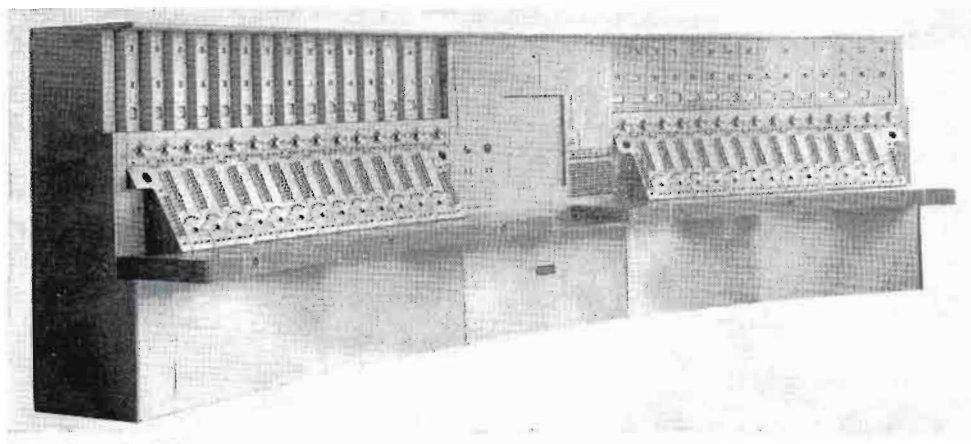

SPECIAL AUDIO EQUIPMENT

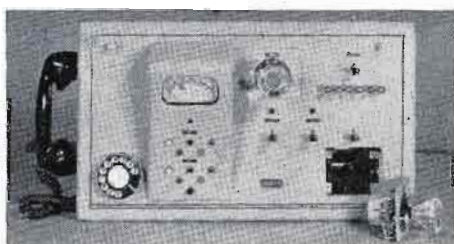
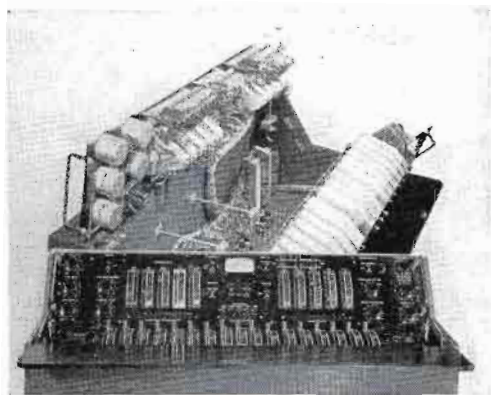

LEFT—Special control console built for DuMont Telecenter, New York City.

ABOVE—Tape control cabinet for Washington Studios, U. S. Information Agency.

BELOW—Transmitter control and audio, WNYC, New York City.

BELOW—Dual tape room recording racks (rear), part of U. S. I. A.

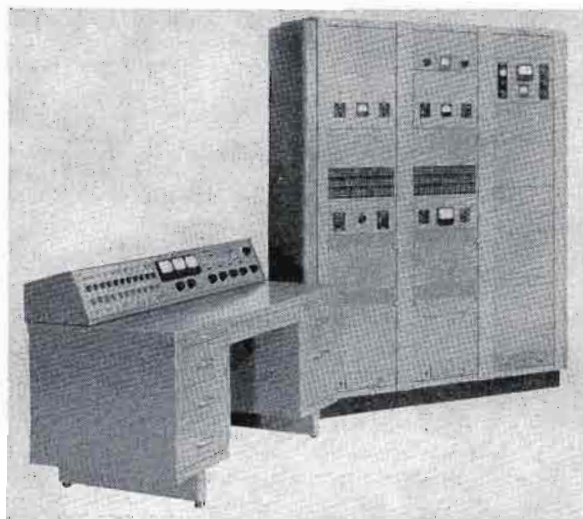
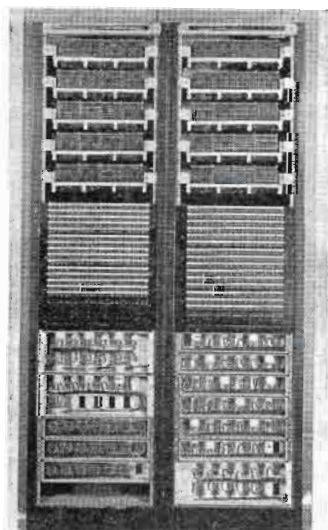

BELOW—Inside view of special audio control cabinet.

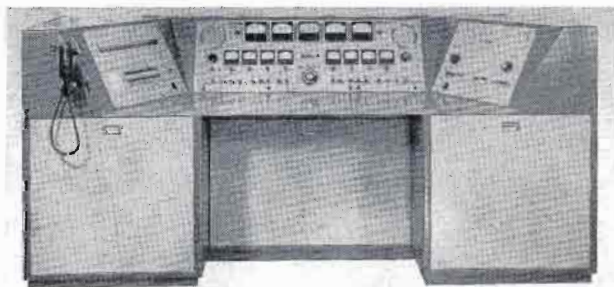
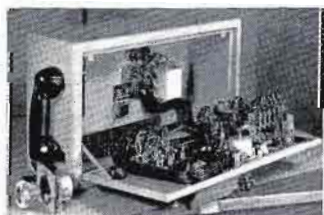

ABOVE—Special control console manufactured for Erie County Police Dept., Buffalo, N. Y.

M-5236 GATES DUALUX DUAL SPEECH INPUT EQUIPMENT

This very new Gates speech input console provides complete dual channel operation combined with more facilities than ever before offered in dual channel equipment.

Accommodations include 9 mixing channels, 5 preamplifiers to handle 7 microphones, 4 turntable inputs, 4 tape inputs, 2 high gain program amplifiers, high output plug-in monitoring amplifier, triple speaker muting/warning light relays, dual VU meters, regulated power supply plus key switching of nearly every conceivable circuit used in multi-studio operation today.

Two entirely new and exclusive features are: (1) inbuilt cue intercom and (2) a four-position variable, high-pass equalizer, front panel controlled. — These two features permit the operator greater control than ever before. He may talk and listen on major circuits such as studios and remote lines plus listening on every circuit with the speaker/microphone front panel mounted. — The variable filter permits the operator to instantly correct or improve faulty quality caused by hum on remote lines, booming microphones or other causes.

On the following pages, full detail and large functional diagram tells why the Gates Dualux will fill the most exacting requirements for more complex audio installations.



Dualux Model M-5236. — Modern low
and wide styling is combined with more
features than ever before.

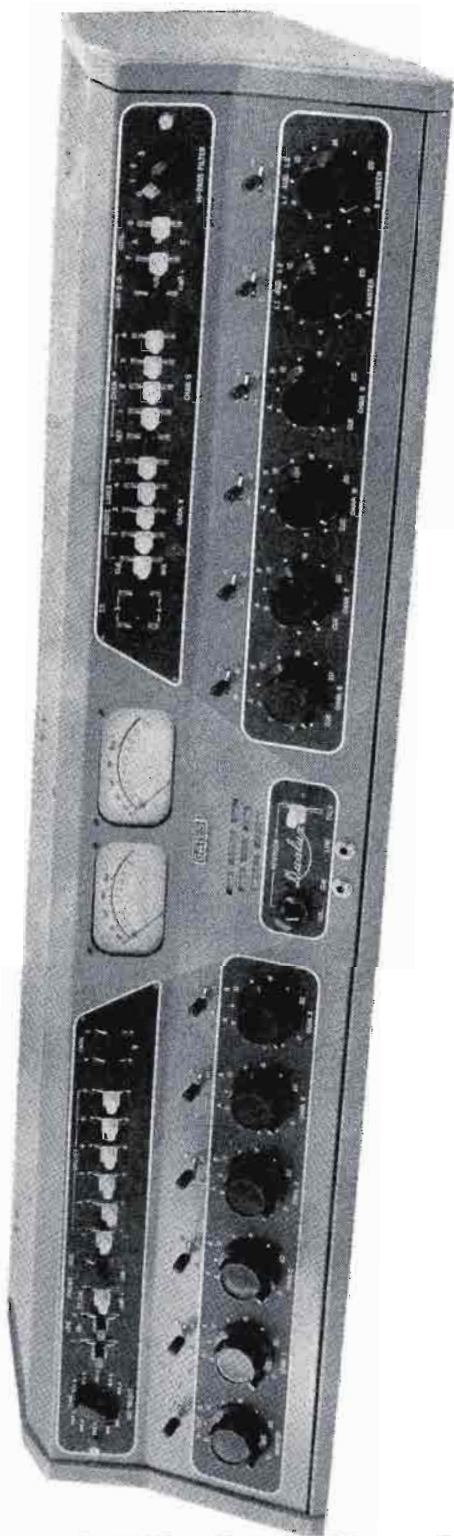

GATES

DUALUX DESCRIPTIVE INFORMATION

MIXING CHANNELS: Nine key controlled.

MICROPHONE INPUTS: Seven—three direct, two switched into channel four, and two into channel five.

TURNTABLE INPUTS: Four, switched into channels six and seven.

CUE POSITION: On mixing channels six through nine, to allow cueing and program preview of any of these channels by cue-intercom system or panel phones.

NETWORK INPUT AND FOUR TAPE INPUTS: Switched into channel eight in the upper position, switched into channel nine in the lower position and terminated in the center, or off-position. With the switching of these inputs into either channel, any sequence may be followed with proper fading instead of dumping the the signals in.

FIVE REMOTE LINE INPUTS: Switched into channel nine in the lower position for mixing, receiving program cue in the upper position, and terminated for off/talk-back/over-ride facilities in the center position.

ISOLATION TRANSFORMERS: In channels eight and nine to permit 600/150 ohm input lines, balanced or unbalanced.

HIGH-PASS FILTER: On front panel for program channel A. Flat position and three selected response curves. Allows immediate elimination of hum and/or rumble on any circuit into channel A. See curve.

EIGHT UTILITY SWITCHES: On front panel for expansion of any section of console operation and/or addition of special facilities. Terminal board furnished attached to rear of cabinet.

FRONT PANEL PHONE JACKS: One to monitor the output of program amplifier 1, program amplifier 2, or the turntable cue bus. One connected to cue-intercom system.

HIGH GAIN PROGRAM AMPLIFIERS: Both use cascaded interstage control for master gain to permit optimum signal to noise ratio for any condition.

MUTING: All mixing channel keys provide switch contacts for muting or auxiliary switching. See Muting Relays.

TWO FULL PROGRAM OUTPUT CHANNELS and amplifiers to permit high quality operation with emergency failure protection. Levels adjusted to permit rapid changeover without re-adjustment.

HIGH QUALITY MONITORING AMPLIFIER: May be switched to pick up output of program amplifier 1 and program amplifier 2, or an external input such as off-the-air monitoring. Bridging transformer and attenuators allow monitoring lines without loading and blasting. Monitor gain control a high quality step type attenuator. Plug-in type. Mounts on panel and shelf assembly.

PATCH PANEL: Main circuits brought to terminal board and strapped together so that normalizing jacks may be used for patching.

(Continued next page)

Rack or cabinet mount panel and shelf assembly accommodates the plug-in monitoring amplifier, relay unit and plug-in regulated power supply.

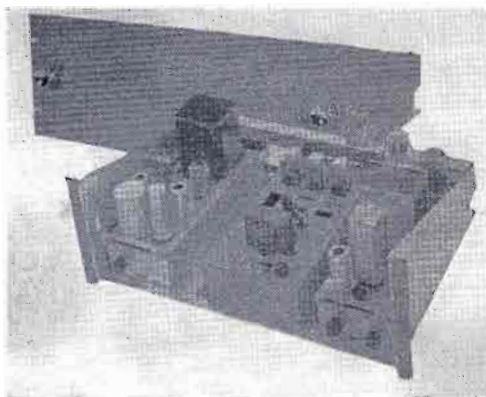

DUALUX GENERAL INFORMATION

PRINTED WIRING: On preamplifiers and program amplifiers. Not to be confused with printed circuit.

POWER SUPPLY: Fully regulated, mounts on panel and shelf assembly.

INTERCOM SYSTEM, combined with cueing facilities, includes following features:

- Interlocked so that it cannot interfere with programming.
- Eight external intercom circuits, selected with front panel switch.
- Eight cueing circuits, selected with front panel switch.
- Automatic gain cue-intercom amplifier to take care of level variations within 20 db.
- All inputs and outputs have pads and isolation networks, where necessary, so that any circuit can be selected and used without adjusting gain control if levels within 20 db. of normal level.
- Front panel volume control for use on signals that are more than 20 db. from normal.
- Cue-intercom speaker, volume control and press-to-talk switch grouped in center of main panel for ease of operation.
- Front panel phone jack will cut off cue-intercom speaker when phone plug inserted.

MUTING RELAYS: Three provided with contacts for monitor speaker muting, intercom speaker muting and warning lights, located on relay deck.

RELAY POWER SUPPLY located on relay deck and independent of main power supply.

EXTRA PREAMPLIFIERS: Provision and power available for two extra preamplifiers for mounting in console cabinet in addition to the five standard ones.

INPUT IMPEDANCES: 30/50-150/250 ohms, balanced or unbalanced, into preamplifiers. 150/250 ohms, unbalanced, into turntable inputs. 600/150 ohms, balanced or unbalanced into network, tape and remote lines.

OUTPUT IMPEDANCES: 600/150 ohms, balanced, with center-tap grounded if desired, on program line 1 and program line 2. 600 ohms on intercom outputs. 600 ohms on monitor amplifier output, speaker impedance is 1800/2000 ohms for three speakers paralleled on 600 ohm output.

VU METERS: Two high quality four-inch VU meters, illuminated. One across program line 1 at all times, the second one may be switched to program line 2 or across program line 1 for emergency use. Both meters calibrated for +8 dbm output on line terminals.

STYLING: Fingertip operation of all controls. Only 7 1/2" high for easy, over the top vision. Front panel drops down to service, audio section hinges up (see Gatesway, Page 95). Panel slope correct for easy upper line vision and control. Non-glaring finish in rich two-tone metallic green and beige.

Graph showing 4 curve positions of the Dualux front panel controlled variable high-pass filter.

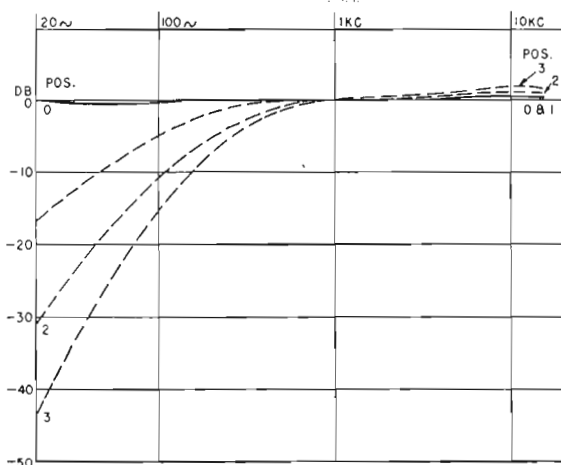

M-5236 DUALUX SPECIFICATIONS

1. Microphone to Program Line Output:

GAIN: 104 db, ± 2 db at 1000 cycles.
RESPONSE: ± 1.5 db from 30 to 15,000 cycles.
DISTORTION: 1% or less from 30 to 15,000 cycles at +8 dbm.
1.5% at +18 dbm output.
NOISE: 60 to 65 db below +8 dbm output, with -60 dbm input.
CROSSTALK: Below noise level with normal levels and control positions.

2. Turntable, Net, Tape and Remote Inputs to Program Line Output:

GAIN: 61 db, ± 2 db at 1000 cycles.
RESPONSE: ± 1.5 db from 30 to 15,000 cycles.
DISTORTION: 1% or less from 30 to 15,000 cycles at +8 dbm.
1.5% at +18 dbm output.
NOISE: 70 to 75 db below +8 dbm output, with -10 dbm input.
CROSSTALK: 70 db or lower between channels with normal levels and control positions.

3. Monitoring Amplifier:

GAIN: Sufficient to adjust to maximum output with normal levels and control position.
RESPONSE: ± 2 db from 50 to 15,000 cycles.
DISTORTION: 1.5% or less from 50 to 15,000 cycles at normal +30 dbm output.
3% or less at maximum +38 dbm output.
NOISE: 60 db below +30 dbm output, with normal levels and control position.
CROSSTALK: The monitoring amplifier introduces no crosstalk in the console.

4. Cue-Intercom System:

Amplifier is response corrected for best intelligibility. Has 20 db limiting to prevent blasting. Amplifier self-contained and speaker front panel mounting including level control and operations switch.

5. Hi-Pass Filter:

See Graph, Page 91, for full information on typical operation.
Response ± 3 db of typical curves shown on graph.

6. Mechanical:

SIZE: 46 1/2" wide, 7 1/2" high with lid down, 12 1/2" with lid up, 15" deep.
WEIGHT: Console 62 lbs., panel and shelf with equipment 39 lbs., total packed weight 205 lbs. Cubage 9.
PRIMARY POWER: 115 volts, 50/60 cycles, approximately 115 watts.
FINISH: Cabinet in medium gloss gray, front panel in two-tone metallic deep green and beige with escutcheons in anodized black and aluminum letters. Control knobs supplied with kit of color disc inserts for coding.

7. Tubes:

(20) 5879, (3) 12AU7, (2) OA2, 6AQ5, (1) 12AX7, 6AK6, 5146, 6080.

Plain rear view illustrates how console may be set against wall, as all terminations are made on inside for both electrical and mechanical protection.

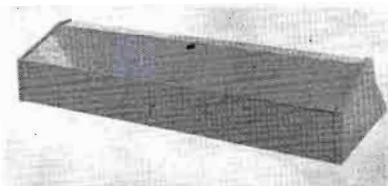

ORDERING INFORMATION M-5236 CONSOLE

Dualux Has Printed Wiring:

Printed wiring is a superior method of wiring certain types of audio amplifiers. Not to be confused with printed circuit, the printed wiring method applies a heavy copper conductor to a laminated base. All components are then attached to this base quite the same as if ordinary wire was used. Printed components are never employed. The advantages of printed wiring are exact uniformity, extreme ease in cleaning and more secure soldering. Best of all is the speed in manufacturing which means greater quality for less cost. Gates manufactures its own printed wiring with modern processes recently installed.



Printed wiring program amplifier.

M-5303 sub-station for studio intercom to talk back to control board. Includes matching transformer.

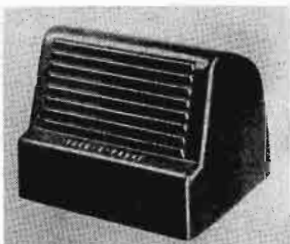

ORDERING INFORMATION

M-5236 Dualux dual channel speech input console complete with tubes and ready to use	\$1650.00
TK-244 100% spare tube complement	52.60
M-5303 Intercom sub-station	16.00

Functional Diagram M-5236 Dualux Speech Input Console.

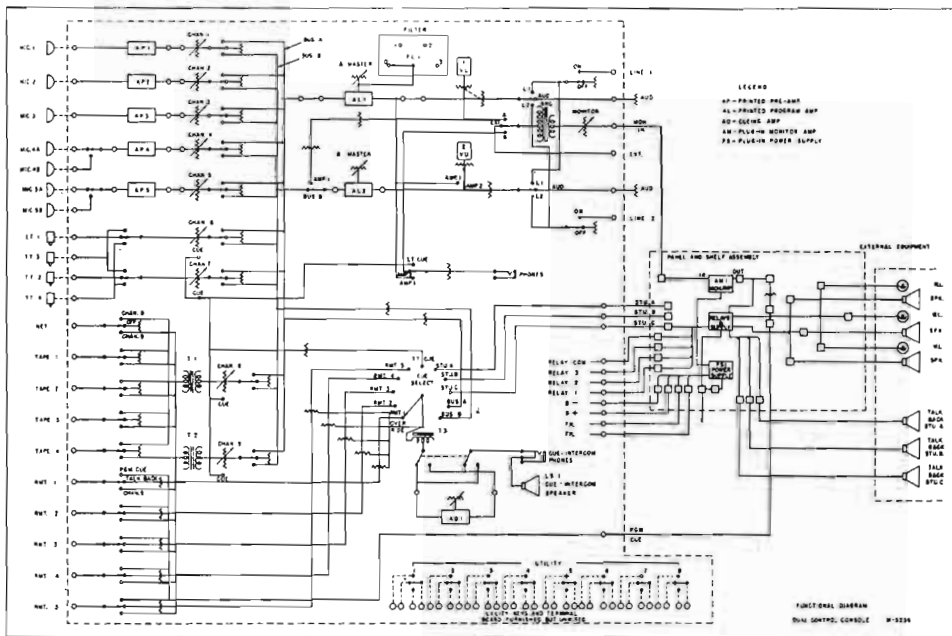

GATESWAY SPEECH CONSOLE



The engineering development of the new Gatesway speech input console is the unified contribution of many Gates engineers, both mechanical and electrical. — The Gatesway is all new. Electrically, you will find many completely new features. For the first time, inbuilt cue-intercom, self-contained variable high-pass filter and many more control functions.

Eight mixing channels through ingenious key control may handle up to 6 microphones, 4 turntables, 4 tape inputs, numerous remote lines, network and many other circuits via auxiliary keys included.

Printed wiring adds to reliability, easy serviceability, and best of all, more value at lower cost. — Nothing has been spared to make this new Gates product the very finest in its field. Checking the specifications, illustrations and functional drawing on succeeding pages will accentuate this statement.

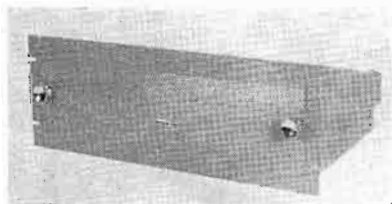

The PAS-1 panel and shelf assembly accommodates the power supply, monitor amplifier and relay chassis. Size: 19"x7".

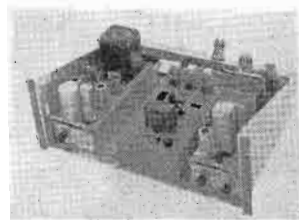

Inner view of panel and shelf assembly. Both power supply and monitoring amplifier are plug-in. Note that relay chassis has knock-outs for 2 more relays for either future expansion or pertinent individual requirements of the user.

GATESWAY SPEECH INPUT EQUIPMENT

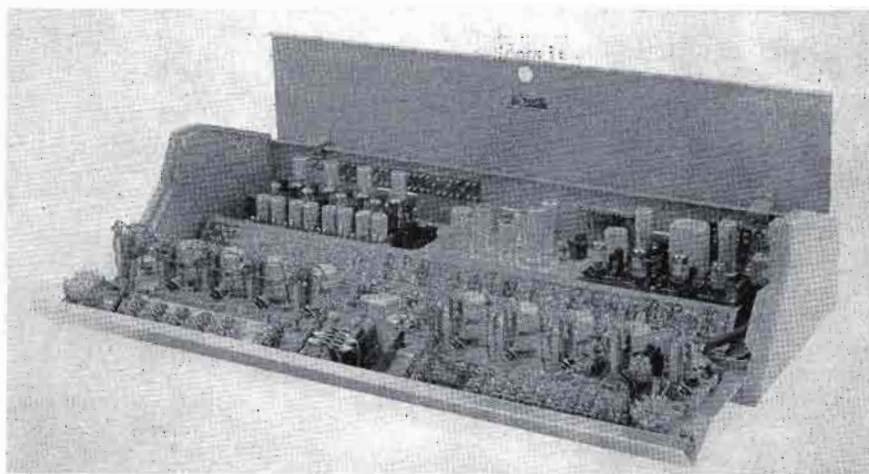

Above: The rear view shows no terminations. All connections are made at the inside front of the console. Flip open the lid, swing down the front panel and all terminations are at the finger tips.

Serviceability is a must in Gates designs. Certainly the above open view indicates that the maintenance engineer has been foremost in mind. Complicated cabling has been minimized through functional location of inner components. This means less opportunity for cross-talk. Major circuits have patch panel take-off—another Gatesway exclusive.

Right: Adding to serviceability, the entire amplifier framework hinges up. In this way, every under chassis connection may be instantly reached. Easily kept clean too.

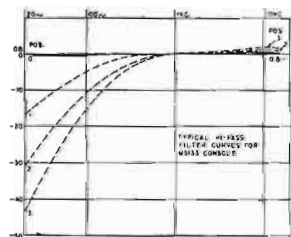
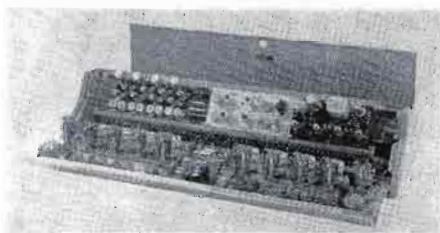

Above: Curve of hi-pass filter. Three degrees of low frequency cut-off may be inserted without clicks or loss of gain. This feature is indispensable for booming microphones, moving sets or woofing remote lines.

Right: The M5303 sub-station for use with the self-contained Gatesway cue-intercom amplifier. Includes matching transformer. Intercom is automatically muted when live microphones adjoin.



GATESWAY SPECIFICATIONS

MIXING CHANNELS: 8 ladder type. Ninth mixing channel may be added in place of monitor gain control which is moved to chassis of monitor amplifier.

MIXER KEYS: Selects each mixing control into: (a) program amplifier, (b) monitor/emergency amplifier, (c) cue amplifier/speaker. Also provides speaker/warning light control through relays included.

TURNTABLE INPUTS: 4, key selected into mixing channels 5 and 6. Connects turntables, through mixer, to: (a) program amp., (b) monitor amp., (c) cue/speaker amp.

TAPE INPUTS: 4, key selected into mixing channels 7 and 8. Connects tapes, through mixer, to: (a) program amp., (b) monitor amp., (c) cue/speaker amp.

NET INPUT: 1 key for network or any 600 ohm line into mixing channels 5 or 6, to: (a) program amp., (b) monitor amp., (c) cue/speaker amp.

REMOTE LINES: 4, key selected into mixing channels 7 and 8. Key up—feeds program cue to remote line. Key center—feeds cue/speaker amplifier to remote line for both talking and listening. Key down—remote line on air.

CUE SPEAKER/AMPLIFIER SELECTOR: Selects cue/speaker amp. for both talk and listen into: all remote lines, 3 studios and utility line. Selects to listen only on turntables, tape recorders, audition buss and program line.

MICROPHONE INPUTS: As wired, accommodates 5 into 4 preamplifiers. Additional mic input may be had by using utility key 5 into mixing channel 3.

UTILITY KEYS: 5 provided, unwired, located to left upper center of VU meter. Provided for specific requirements of individual installation such as additional remote lines, tape inputs, etc.

EQUALIZER CONTROL: Four positions: off and 3 degrees of low frequency cut-off (see curve).

INTERCOM KEY: Push down to talk, normal position to listen.

JACKS: For phones, 2 supplied, to listen on program line and cue amp. Use of phones on cue amp disconnects speaker.

OUTPUT EMERGENCY KEY: Located above master gain. In case of failure of program amplifier, the output of the monitoring amplifier may be instantly connected to the program line. Does not disconnect loudspeakers.

MONITOR INPUT KEY: Located above monitor gain control. Allows switching of monitoring amplifier to: (a) padded output of program amplifier, (b) audition buss, and (c) external pair for any other input.

VU METER: Standard 4" scale B illuminated. Reads output of program line, peaking to 0 VU when output level is +8 VU.

PATCH PANEL TAKE-OFF: Jumpers provided for patch panel interlock at output of all preamplifiers and input and output of both program and monitoring amplifiers.

IMPEDANCES:

Mic inputs...30/50 and 150/250 ohms.

TT inputs...150/250 ohms.

Tape inputs...500/600 ohms.

Net input...600 ohms.*

Rmt inputs...600 ohms.*

Ext. input (monitor)...600 ohms.

Pro. amp. output...600 ohms.

Mon. amp. output...600 ohms.

Loudspeakers...matching to 500/600 ohms.**

Headphones...5000 ohms or higher.

Ext. cue speaker...600 ohms.

* May be adjusted to other NARTB standards such as 50/150/250 by tapped primary on isolation transformer.

** Speakers in parallel circuit. Example: 2 speakers 1000 ohms, 3 speakers 1500 ohms, etc., by use of speaker matching transformer on speaker.

GAIN: From mic input to program line output, 104 db. From remote line, net, tape and turntables to program line output, 61 db.

CUE AMPLIFIER: Fixed pads at all circuits provide adjusted uniform input level to proper cue speaker level. Also provides proper level to operate directly remote cue intercom speaker at room level.

NOTE: All gains stated ± 2 db.

RESPONSE: ± 1.5 db 30-15,000 cycles (standard mode of operation). ± 2.0 db 30-15,000 cycles (emergency circuits).

DISTORTION: 1% or less 30-15,000 cycles all program circuits measured at +8 dbm output. 3% or less 50-15,000 cycles all monitoring circuits measured at +38 dbm.

NOISE: Program circuit...60 db or better below +8 dbm measured at -60 dbm input. Monitoring amplifier...65 db below +38 dbm output.

CROSS-TALK: Below microphone channel noise level within normal inputs and control position.

(Continued next page)

GATESWAY SPEECH INPUT EQUIPMENT

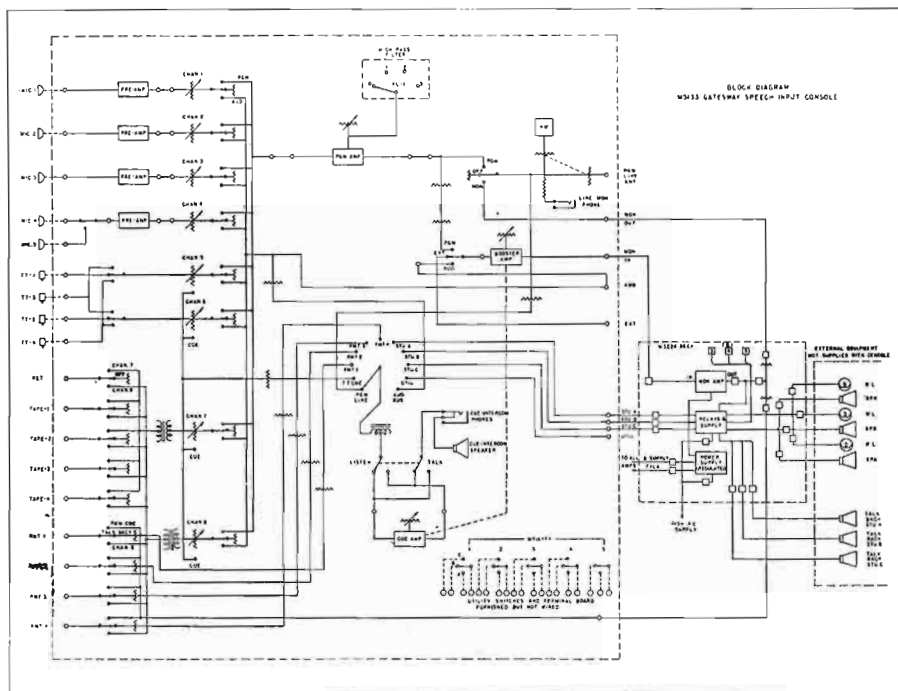

SPECIFICATIONS (Continued)

TUBES: Preamplifiers...two 5879, total 8. Program Amplifier...three 5879, one 12AU7. Booster Amplifier...two 12AX7. Cue Amplifier/Speaker...one 5879, one 12AX7, one 6AK6. Monitor Amplifier...two 5879, two 6AQ5, one 12AU7. Power Supply...two 5V4G, one 6080, one 5879, two OA2.

Total tubes: (15) 5879, (3) 12AX7, (2) 6AQ5, OA2, 12AU7, one each 6AK6, 5V4G, 6080.

RELAYS: 3 provided, telephone type with contacts for muting loudspeakers and breaks 115 volt circuit for warning lights up to 60 watts per light. Room for 2 added relays on chassis where unusual muting or control requirements exist. Relays operate from console power supply.

SIZE: 39" wide, 15" front to back, 7½" high. Height (lid up), 12½".

WEIGHT: Net, Console, 52 lbs. Panel and shelf with equipment, 39 lbs. Total packed weight, 175 lbs.

PRIMARY POWER: 115 volts, 50/60 cycles, approximately 105 watts.

FINISH: Cabinet in medium gloss gray. Front panel two-tone metallic emerald green and beige with escutcheons in etched black and aluminum lettering. Control knobs supplied with kit of color disc inserts for coding.

ORDERING INFORMATION

M-5133 Gatesway speech input console with tubes, relays, complete ready to install	\$1295.00
A94401 Extra relays for additional muting, etc.	10.45
M-5303 Sub-station for intercom use only, includes matching transformer	16.00

Gates reserves the right to alter specifications stated herein to effect improvements in the product and manufacturing economies.

GATES

97

THE GATES "YARD"



Above: The Gates "Yard" mounted on M4947 micarta top desk.

Only 5 $\frac{3}{4}$ " high and exactly one yard wide, this new and modern speech input console offers both radio and TV broadcasters wide facilities and unusual ease in servicing. — The inbuilt cueing amplifier with front panel speaker provides instant operator checking of all operating circuits without disrupting the house monitoring system. — Complete specifications on succeeding pages.

THE GATES "YARD"

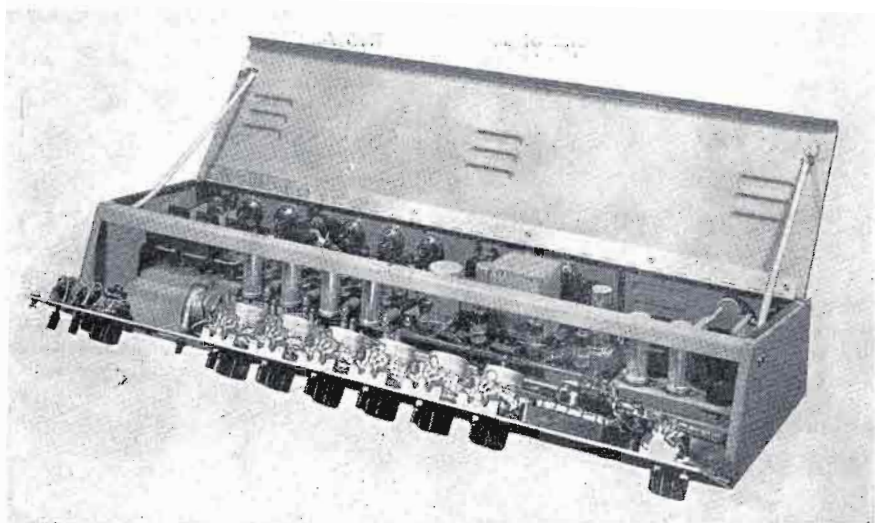

Printed wiring for reliability, triple monitoring amplifiers with grid shunt speaker muting, cueing amplifier and front panel speaker selectable to all usable circuits, six mixing channels, four preamplifiers, new four-stage program amplifier, dual turntable/projector facilities, instantaneous accessibility, self-contained including power supply, mixer buss switchable to second external amplifier, recessed 4" illuminated VU meter — and new performance standards.

Functional design is emphasized. The most used mixing controls in the center. Master gain for the right hand with adjoining VU meter. Cueing speaker and other secondary switching facilities are to the left. Low and wide, vision over the console is unhampered and the massive eye catching appearance makes the "Yard" a show piece of studio equipment.

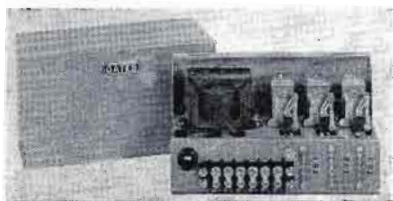

M5050 Relay Unit

An optional desk or cabinet mount unit accommodates three relays and their power supply. Primarily designed where studio warning lights are used. Contacts also provided for loudspeaker muting from each relay in case additional muting of more than 3 speakers, as provided standard in the "Yard," is desired. Relays operate from spare contacts provided on the "Yard" mixer keys.

"YARD" SPECIFICATIONS

NUMBER OF MIXING CHANNELS: Total of six. Key controlled above each control. Mixers ladder type, 20 s'ops 2 db.

PREAMPLIFIERS: Four provided, 2 stage, printed circuit.

PROGRAM AMPLIFIER: 4 stages provide high gain but lower noise through gradual amplification. Printed wiring employed.

MONITOR AMPLIFIERS: Three separate one-watt amplifiers connect directly to speakers and employ grid shunt muting.

POWER SUPPLY: Self-contained full wave transformer type for all filament, bias and plate voltage.

MIXER KEYS: Above each mixing control. Connects each channel to either program buss or cue amplifier buss (see cue amplifier below). Also operates grid shunt muting of monitoring amplifiers and provides contacts for operation of M5050 optional relay panel.

TURNTABLE INPUTS: 150/250 ohms hi-level selected into mixing channels 5 and 6 via keys. 2 provided.

PROJECTOR INPUTS: 150/250 ohms hi-level selected into mixing channels 5 and 6 via keys. 2 provided.

REMOTE INPUTS: 4 circuits key selected 500/600 ohms balanced to ground. Includes cueing to remote lines. Operates through mixing channel 6.

CUEING AMPLIFIER: Self-contained 3-stage with loudspeaker on front panel. Used with master select switch.

MASTER SELECT SWITCH: Selects cueing amplifier or phones across: (a) Remote lines, (b) any mixing channel, (c) individual turntable circuits, (d) individual projector circuits, (e) both program line outputs.

VU METER: 4" illuminated directly adjacent to master gain control.

OUTPUT SWITCH: Selects program amplifier output to choice of 2 lines.

MASTER GAIN: To extreme right, adjacent to VU meter.

HEADPHONES: 3 jacks to allow use of phones across either program line or cue amplifier circuit.

SIZE: 5 3/4" high, 12 1/2" deep, 36" wide (one yard). Panel slope 20°. Optional M4947 desk: 29 1/2" high, 23" deep, 36" wide.

WEIGHT (packed): Console 140 lbs. Cubage 9. Desk 88 lbs. Cubage 6.

FINISH: Panel anodized black on natural 2 SH aluminum. Knobs black and supplied with kit of decal color inserts. Cabinet medium gloss gray.

ACCESSIBILITY: Front panel hinges down, lid of cabinet raises up, exposing all internal equipment for 100% servicing. Individual amplifiers quickly removable if ever need be.

(Continued next page)

Below: The low and wide "Yard" Console

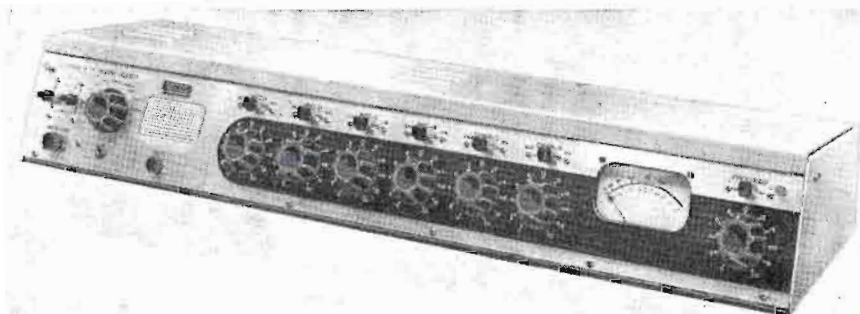

THE "YARD" SPEECH CONSOLE

SPECIFICATIONS (Continued)

GAIN (rated ± 3 db):

Mic input to program line, 103 db.
Remote line to program line, 60 db.
Turntable or projector to program line, 60 db.

RESPONSE: 30-15,000 cycles $\pm 1\frac{1}{2}$ db.

DISTORTION: 1% or less 50-15,000 cycles at ± 18 dbm to program line.

NOISE: Measured at -60 db to preamplifier input and 18 dbm output from program amplifier, the overall noise reduction is 60 db. With -50 db input, overall noise reduction is 70 db.

MONITOR: Output per amplifier ± 30 db (1 watt). Adjusted for proper gain to develop full output under all normal operating requirements.

IMPEDANCES: Preamplifier inputs, 30/50 and 150/250 ohms.

Turntable, projector inputs, 150/250 ohms.
Remote lines input, 500/600 ohms.
Line output, 500/600 ohms.

Monitor amplifier output, 3 outputs of 4 ohms.

POWER: 115 volts 50/60 cycles, 90 watts.

TUBES: 11 each 58T9; 4 each 6AK6, 12AX7; 1 each, 12AU7, 5Y3GT. Total of 21.

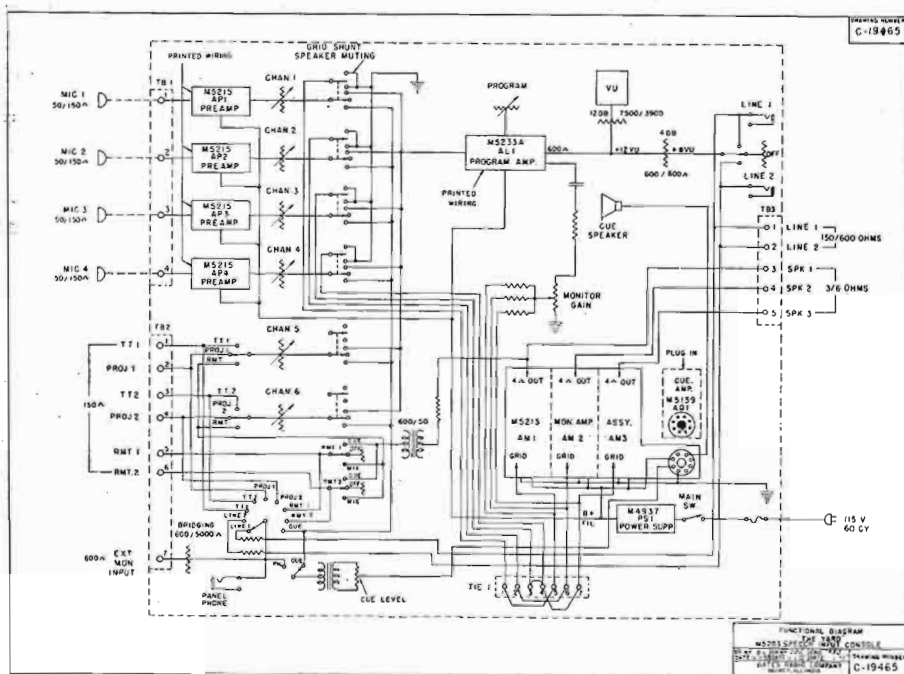

ORDERING INFORMATION

M4885A Yard console complete and with screw type termination strip	\$925.00
M4885B Yard console complete and with Cannon XL connectors for terminations	925.00
M5050 Optional relay unit	63.50
M4947 Desk (chair not supplied)	115.00
TK-188 100% spare tube kit	33.25

Specifications on this product may be altered from time to time where improvement and/or manufacturing economies may be effected.

"YARD" ACCESSORIES

Output Switching Unit

Designed to operate in the output of the Yard, or any speech console. Function is to connect the output of two consoles or a console and one other program source to the program line and spare program line. When switched to A, source A is connected to program line and source B is connected to spare. When switched to B, source A is connected to spare and source B is connected to program line. Pilot lights indicate circuit switching. Frequently used in feeding two circuits to diverse points to provide a simple supervised control point, allowing selective feeding and spare circuit for monitoring or other uses. Size: 9 1/2" wide, 5 3/4" high, 11 3/4" deep. Matches Yard in panel slope, design and finish.

M5069 Output Switching Unit \$75.00



Patch Panel Cabinet

Contains two rows of single PBX type jacks of the closed circuit type along with indicator strips above each row. Jacks are terminated to numbered terminal block in the back of the cabinet. Has multiple usage. All jacks may be used for extra input circuits such as microphones, remote lines, tape recorders, projectors, etc., or one row may be used for input circuits and the other for output circuits such as recorder feed, network feed, loudspeakers, etc. Size: 9 1/2" wide, 5 3/4" high, 11 3/4" deep. Matches Yard in panel slope, design and finish.

M5070 Patch Panel Cabinet \$125.00
S32 Two-foot Patch Cord, plugs both ends 8.70



Muting/ Warning Light Unit

This desk or wall mount relay unit is an optional accessory for use with the "Yard" console. Allows relay muting of 3 loudspeakers plus contacts for warning lights. Has self-contained DC power supply for operation of relays. Operates directly from any mixer key sequence by slight modification of console wiring. As grid shunt speaker muting is already provided in the "Yard", the main purpose of the M-5050 is to provide warning light facilities. It may also be used with any external monitoring amplifier where the house speaker system demands more wattage than provided in the "Yard".

M5050 Muting/Warning Light Unit \$69.50

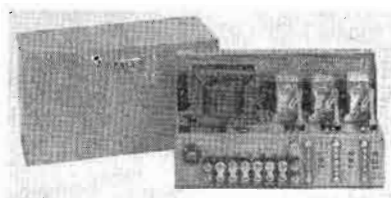

Special Yard Desk

A worthy accessory to the modern Yard console. Back portion of desk tilts back to provide exact panel slope in proportion to viewing level and correct wrist action in operating mixing and level attenuators. Has formed genuine black Micarta top on seasoned 7-ply wood. Sides are of furniture grade stretcher level steel, ribbed for extra strength. Leveling screws provided. Finished in hand-rubbed medium gloss gray. Size with Yard console mounted: 34 1/2" high, 36" wide, 23" deep. Desk disassembles for portability. Shipping weight, 90 lbs. Cubage: 9 1/2".
M4947 Desk (chair not supplied) \$115.00

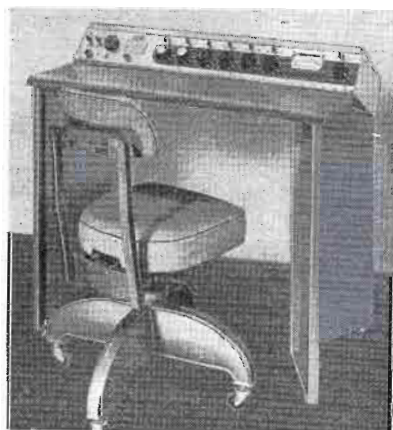

OTHER YARD ACCESSORIES

Several fixed and variable equalizers for equalizing remote, network, projector lines or overall correction of line between studio and transmitter, will be found listed in this catalog. Loudspeakers, microphones, stands, repeater transformers, and all other items to complete the studio installation are listed in this catalog. Kindly refer to Index.

STUDIOETTE SPEECH INPUT CONSOLE

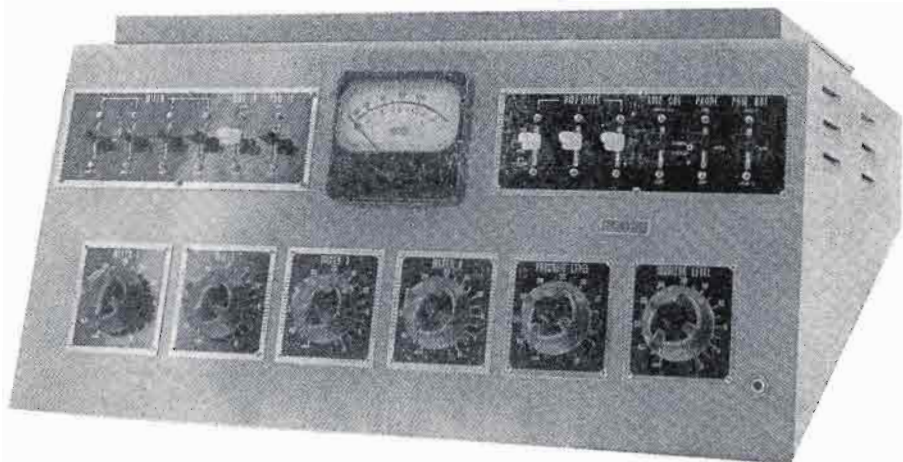

Where a modest size, high quality speech input console is required, the wide facilities of the 52-CS Studioette will meet many requirements for both radio and TV aural control. Completely self-contained including power supply, relay units and monitoring amplifier, the Studioette fits minimum space requirements. The ingenious engineer will also note that two Studioettes operated either side by side, or at separate points will often provide greater facilities and ease of control than the use of one larger control board.

GENERAL CONSTRUCTION: In cabinet 24" wide, 10" high and 21½" deep, having a front panel slope of 30°. Top hinges up to expose all under-chassis wiring and relays. Entire cabinet hinges up to expose terminal boards and for tube change.

BASIC ELECTRICAL DESIGN: Consists of four mixing channels, master and monitor gain controls, two preamplifiers, program and monitor amplifiers, complete with duplicate speaker/warning light relays and full wave transformer type power supply.

MIXER: Four channels each with ladder type controls. Channels 1 and 2 operate from output of preamplifiers. Channels 3 and 4 are combination turntable/projector, remote and network channels, by means of lever key selection.

MICROPHONES: Four may be accommodated by switch selection into two preamplifier inputs. Switches may be wired to speaker muting relays for any muting/warning light combination desired.

TURNTABLES: Accommodates two turntable channels into mixing channels 3 and 4.

NETWORK: Switches into channel 3 when turntable not in use.

REMOTE LINES: Switches into channel 4 when turntables not in use. Accommodates three remote lines with complete override and cue facilities.

OTHER SWITCHING: Switching circuits are provided for: (a) switching output of entire mixer to choice of two external program amplifiers, (b) handling remote cue from padded output of monitoring amplifier, (c) selection of headphone jack across network, program line and remote lines, and (d) selection of program amplifier output to choice of two lines.

GAIN CONTROLS: Two supplied, (a) program amplifier, and (b) monitoring amplifier.

VU METER: Standard 4" fully illuminated.

AMPLIFIERS: Preamplifiers, two-stage type, transformer coupled input and cathode follower output. Program amplifier, four stages, with abundance of gain at low noise and distortion. Monitoring amplifier, three stages, 4 watts output.

RELAYS: Two supplied. Operate from main power supply. May be wired in any sequence in conjunction with microphone switches to mute loudspeakers and supply warning light switch break.

TURNTABLE CUEING: Both turntable channels have cue switching at infinity position. These may be connected to any external amplifier for advance listening on network, remote lines, projectors and turntables.

TERMINATIONS: Numbered and lettered terminal strips on inside base of cabinet is reached by tipping back cabinet.

(Continued next page)

STUDIOETTE SPEECH INPUT CONSOLE

SPECIFICATIONS

MICROPHONE INPUTS: 4 (two mixed at any one time).

TURNTABLE/PROJECTOR INPUTS: 2.

REMOTE LINES: 3 at 500/600 ohms.

ISOLATION TRANSFORMER: Self-contained.

NETWORK: Separate input to mixing channel 3.

RESPONSE: $\pm 1\frac{1}{2}$ db 30-15,000 cycles.

DISTORTION: From preamplifier input to program amplifier output, 1% or less, 50-15,000 cycles at $+8$ dbm output.

MONITORING AMPLIFIER: 2% or less at 4 watts output, 50-15,000 cycles.

NOISE: 65 db below $+8$ dbm.

IMPEDANCES: Microphone input 50/250 ohms.

NETWORK AND REMOTE LINES: 500/600 ohms.

TURNTABLES OR PROJECTORS: 250 ohms.

PROGRAM LINE OUTPUT: 500/600 ohms.

MONITORING AMPLIFIER OUTPUT: 500 ohms.

EXTERNAL CUEING AMPLIFIER INPUT: 250 ohms.

GAIN: From microphone input to program line output, 105 db ± 3 db.
From remote network or turntable/projector input to program line output, 60 db ± 3 db.

TUBES: Six 6C5; three 6J7, 6SN7; two 6V6; one 5U4G.

POWER: 115 volts, 50/60 cycles, 125 watts.

(Continued next page)

Below: Studioette cabinet tilts up to reach terminals, tubes and attenuator cleaning.

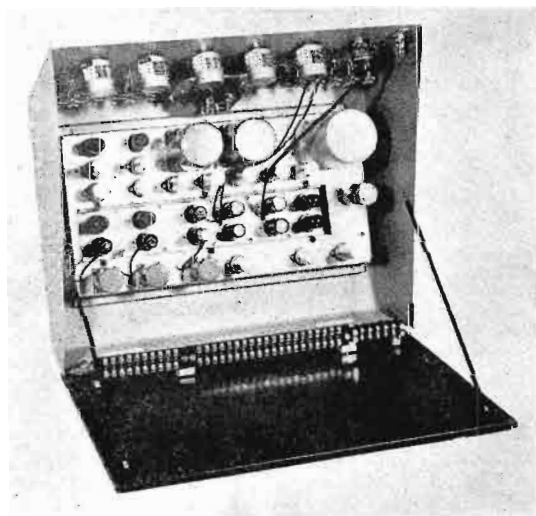

STUDIOETTE SPEECH INPUT CONSOLE

SPECIFICATIONS

(continued)

SIZE: 24" wide, 10" high, 21½" deep.

FINISH: Hand rubbed rose gray with escutcheons in anodized black and natural aluminum.

CABINET: 16 gg cold rolled stretcher level steel resistance welded. Sub-chassis of aluminum.

SHIPPING WEIGHT: Packed, 100 lbs. Cubage: 12 cu. ft.

USAGE

For all speech input requirements, for AM, FM and TV. Also excellent for recording studios, radio workshops, larger public address installations and centralized radio control. Also widely used as sub-console in master control installations.

ORDERING INFORMATION

Model 52-CS Studioette complete with tubes and ready to use \$725.00

TK-106 100% spare tube complement 18.24

NOTE: For desk, recommend Model CB-63 — see Page 127.

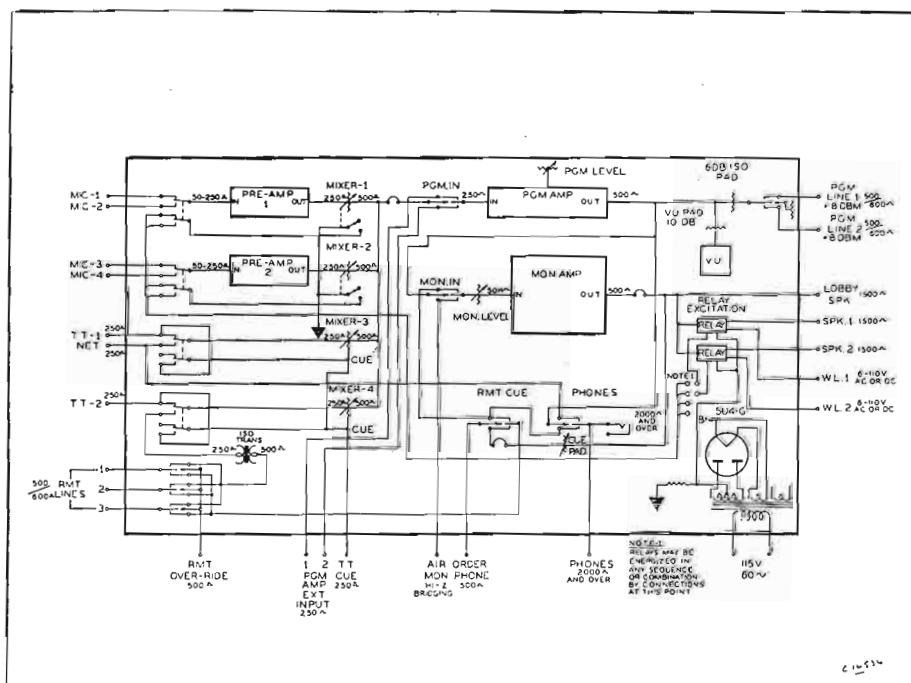

TV AUDIO CONTROL CONSOLE

This console is designed specifically for the demands of audio control in TV. Standing only 7½" high, the two-step panel has the bottom row mixing section sloping toward the operator and the top row vertical. — Utility keys permit a wide range of circuit control to fit personalized needs.

Ten mixing channels may be used for a very wide variation of input circuits. As many as 24 microphones may be accommodated, or the equivalent combination of microphones, projectors, turntables and tapes. Booster amplifiers are placed between each of the two program busses for improved signal to noise ratio and for the use of dual sub-master and master gain controls. Jacks are provided to monitor both output circuits, plus a third jack for direct connection to the intercom system of the TV plant.

Servicing is near zenith in scope. Identical construction as used in the Gatesway console, see Pages 94-97. Includes drop-down front panel, hinged audio strip chassis and dead back — all terminations are to the inside of the cabinet. — The following pages and functional diagram will supply interesting information about this very new Gates product.

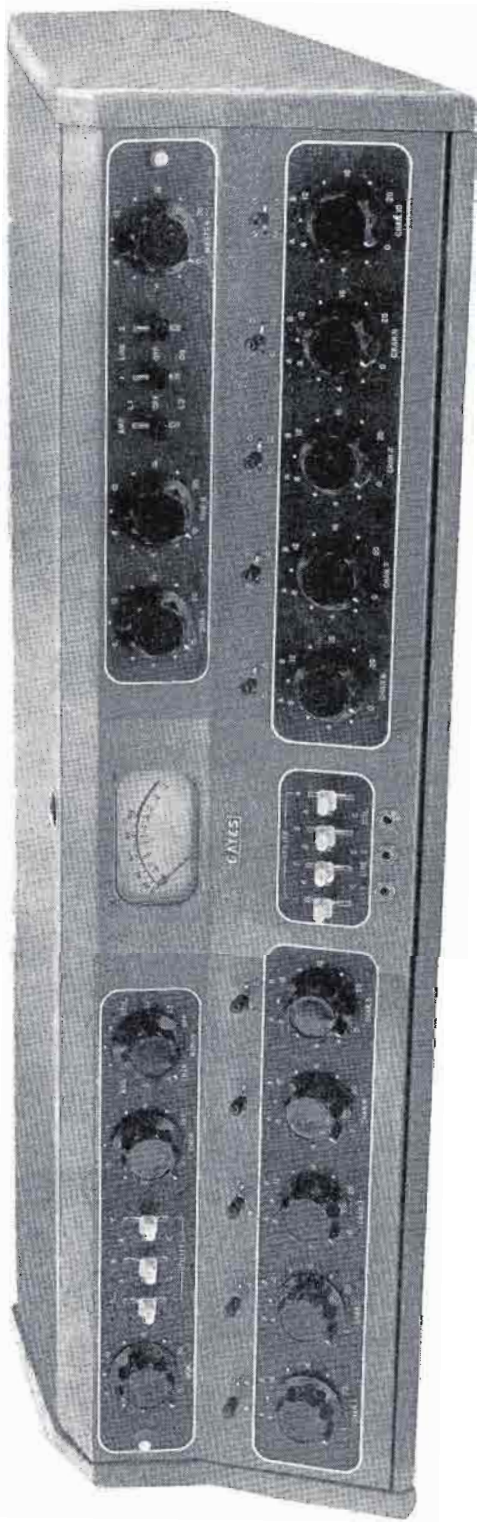

TV audio control console, Model M-5301 — only 7½" high and 39" wide. Finish is in non-glaring two-tone industrial green and beige with cabinet in medium gray.

M-5301 TV Console General Information

TEN CHANNEL MIXER: Six supplied with microphone preamplifiers, four supplied for medium level input. Space provided for four additional preamplifiers if all low level channels desired.

PREAMPLIFIERS: Six supplied as standard. Blank space for 4 more. Input impedances of 30/50 and 150/250 ohms. With use of utility keys, up to 18 microphones may be used with the six preamplifiers.

MICROPHONE INPUTS: By wiring three microphones each into the utility switches and connecting them into seven of the channels a total of 24 are available. Thus, 21 switched and 3 unswitched. Can be used in three groups of seven and one group of three, or two groups of seven and one group of ten for large program productions.

MEDIUM LEVEL INPUTS: If any of the inputs listed above are not required for microphones, they may be used for medium level inputs such as projectors, turntables, tape recorders and remote lines. The microphone preamplifier is not required on medium level channels. Up to 24 available by use of all 10 channels.

BOOSTER AMPLIFIERS: Two connected at output of the two program busses for improved signal to noise ratio in conjunction with sub-master and master controls.

SUB-MASTER OPERATION: Any or all input channels may be switched to either sub-master A or sub-master B control and faded in and out as a group. Sub-master A and sub-master B groups may be used simultaneously or individually with no switching required.

MASTER CONTROL: A low impedance step-type ladder control used to fade in and out the entire program channel. Connected directly after the

converging pad which connects to the output of the two sub-master controls.

PROGRAM AMPLIFIER OUTPUT SWITCHING: Lever key allows output to be switched to program line 1 or program line 2. May also be used to direct the console to one of two master consoles when used for subordinate studio control.

PHONE JACKS: Two standard phone monitoring jacks are connected to each of the two program lines. This allows using one of the lines for programming and the other line for an order-phone line.

INTERCOM PHONE JACK: A two circuit jack is provided to permit the use of an intercom telephone headset connected to the master intercom system in the station.

MONITORING AMPLIFIER INPUT SELECTION: Two eleven-position switches, one feeding into the other, allow monitoring of fifteen of the important circuits in the console. In addition, four utility positions are furnished to bring the total number available up to 19. An off position may be selected on each switch.

- (A) Input of each mixing channel may be monitored ahead of the control. This allows sweeping through a number of microphone inputs and finding one that may be introducing unwanted signal. This microphone may then be faded out until the condition is cleared. It is unnecessary to fade each microphone until offending one is found, thus an important part of the program will not be lost.
- (B) Input channel selector described in (A) above, is connected into the master selector in the "Channel" position. Other positions on the master selector are: input to sub-



The New In Preamplifiers

To provide 10 high quality preamplifiers in one modest sized console, Gates engineers designed the M-5215 preamplifier. Requires only $2\frac{5}{8}'' \times 4\frac{5}{8}''$ mounting space. Use of printed wiring (not printed circuit) requires less space and assures uniform, trouble-free operation. Response: $\pm 1\frac{1}{2}$ db, 30-15,000 cps. Distortion: Less than $\frac{1}{2}$ % at operating levels and noise 90-95 db below +10 dbm output.

M-5301 Television Audio Control Console

master A, sub-master B, output of the master or program amplifier, four utility positions, line 1 and line 2. This complete input selection of the monitoring amplifier allows preview or signal checking of any part of the console at any time.

- (C) **Bridging Transformer on Monitor Amplifier Input:** Since the input of the monitoring amplifier may be switched to any of the circuits during programming, the bridging impedance is 7500 ohms to prevent circuit loading.
- (D) **Monitor Gain Control:** Low impedance step-type ladder control adjusts the levels into the monitoring amplifier. Output impedance of this control is 600 ohms to match amplifier input. This permits a low impedance inter-connecting line between the console and the shelf assembly which holds monitoring amplifier.
- (E) **Signal Level Compensation:** All circuits are padded, where required, to present approximately equal levels into the monitoring amplifier. This allows the input selector to be switched to any and all positions without control changes and fear of speaker blasting.

MUTING: Channel keys provide switch contacts for muting or auxiliary switching. Optional M-4572 relay unit available where speaker muting required. See below.

PATCH PANEL: Main circuits brought to terminal board and strapped together so that normalizing jacks may be used for patching if ever desired.

UTILITY KEYS: Seven provided, in a group of three and a group of four. Two circuit, three position keys standard. Permit expansion of any section of console operation and/or addition of special facilities. Terminal board furnished attached to rear of cabinet, allows wiring of any type of circuit by station engineer.

PANEL AND SHELF UNITS: Plug-in program amplifier, monitoring amplifier, regulated power supply and optional muting relay unit mount on single panel and shelf assembly for rack or inner desk mounting to segregate high and low level circuits.

SPEAKER MUTING RELAYS: M-4572 relay unit (optional equipment) as some TV operations do not require speaker muting. Space provided on panel and shelf assembly to mount a plug-in relay deck. All channel keys provided with contacts to operate muting relays, thus muting operation easily installed if desired.

VU METERS: High quality illuminated four-inch VU meter, calibrated for +8 dbm level into output line. Other calibrations on special order.

INPUT IMPEDANCES: 30/50-150/250 ohms, balanced or unbalanced into the microphone preamplifiers. 150/250 ohms, unbalanced into channels without preamplifiers. 600 ohms, unbalanced into program and monitor amplifiers.

OUTPUT IMPEDANCES: 600/150 ohms, balanced or unbalanced out of program amplifier. 600 ohms, balanced out of line terminals. 600/150/16/8/4 ohms, balanced or unbalanced out of monitor amplifier—factory connected for 600 ohms.

M-4572 Optional Muting Unit

Where speaker muting is required, this unit of the plug-in type, fits in as the fourth unit of the panel and shelf assembly as shown on Page 110. Standard unit includes 3 relays but knockouts provided for 3 added relays if needed. Contacts for both speaker muting and warning light break are provided. Relay power supply, selenium type, is self-contained. Spare contacts are provided on all mixing channel keys and utility keys for any conceivable sequence of relay operation.

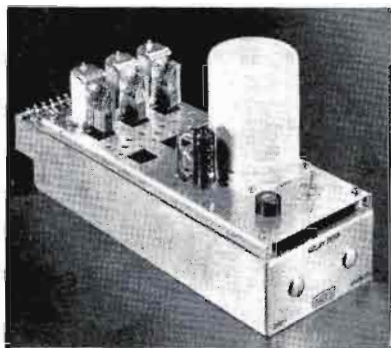

Specifications M-5301 TV Console

Microphone To Program Line Output:

GAIN: Adjusted to 106 db (with Program Amplifier gain control).

RESPONSE: ± 1.5 db from 30 to 15,000 cycles.

DISTORTION: 0.5% or less from 50 to 15,000 cycles at +18 dbm output.

NOISE: 60 to 65 db below +8 dbm output, with -60 dbm input.

CROSS-TALK: Below noise level with normal levels and control positions.

Channels Without Microphone Preamplifiers:

GAIN: 65 db ± 2 db at 1000 cycles.

RESPONSE: ± 1.5 db from 30 to 15,000 cycles.

DISTORTION: 0.5% or less from 50 to 15,000 cycles at +18 dbm output.

NOISE: 60 to 65 db below +8 dbm output, with -10 dbm input.

CROSS-TALK: Below noise level with normal levels and control positions.

Monitoring Amplifier:

GAIN: Sufficient to adjust to maximum output with normal levels and control position.

RESPONSE: ± 2 db from 50 to 15,000 cycles.

DISTORTION: 1.5% or less from 50 to 15,000 cycles at normal +30 dbm output, 3% or less at maximum +38 dbm output.

NOISE: 60 db below +30 dbm output, with normal levels and control positions, ± 3 db.

CROSS-TALK: The monitoring amplifier introduces no cross-talk in the console.

Tubes: (20) 5879, (4) 12AU7, (2) 6AQ5, OA2, (1) 6080, 5V4G.
Additional preamplifiers (2) 5879.

Below: Panel and shelf unit to left requires only 7"x19" panel space and accommodates the program amplifier, monitoring amplifier and regulated power supply, Illustrations 2, 3 and 4. Optional M-4572 relay unit, Page 109, also plugs in this panel and shelf unit.

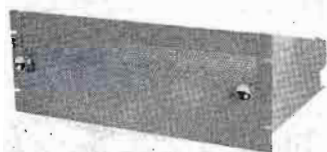

Fig. 1



Fig. 2

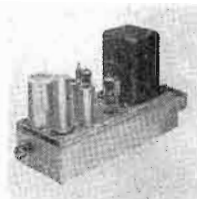

Fig. 3

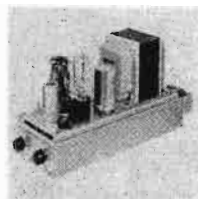

Fig. 4

Ordering Data --- Optional Accessories --- M-5301

M-5301 COMPLETE TV CONSOLE:

Includes six preamplifiers, panel and shelf assembly with program amplifier, monitoring amplifier and regulated power supply mounted, all tubes and ready to use.

\$1595.00

TK-231 100% spare tube complement for M-5301

51.40

M-5304 PREAMPLIFIER KIT:

Includes M-5215 preamplifier, described Page 108, tubes and side shield. Six supplied with M-5301 console as standard. Space provided for four more. Order this kit where additional complete preamplifiers are desired.

M-5304 Preamplifier Kit

\$41.25

TK-239 100% spare tube kit

3.00

M-4572 MUTING UNIT:

Optional equipment. Described Page 109. The M-5328 plug-in base plate and receptacle are necessary for both plug-in feature and terminations. Three relays are standard equipment and knockouts are provided for three more. Spare relays are listed below.

M-4572 Muting Unit

\$119.50

M-5328 Base plate and receptacle

12.00

A-75679 Spare relay

10.45

Functional Diagram M-5301 TV Console

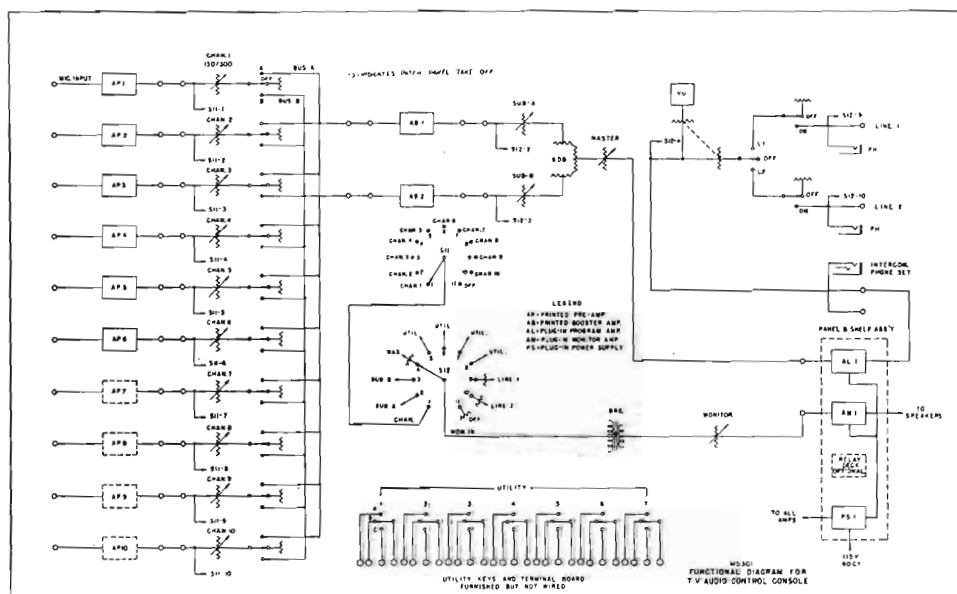

PLUG-IN AMPLIFIERS --- POWER SUPPLY

Gates plug-in preamplifiers, program amplifiers and power supplies are used world-wide in the most exacting radio, television and recording service. — Self-aligning plugs and receptacles of the wiping knife blade type are used in place of ordinary plugs and sockets. This makes possible the complete interchange of any similar unit without re-alignment as well as providing the most secure electrical contact known. All chassis are heavy cadmium plated to prevent marring during the plug-in cycle.

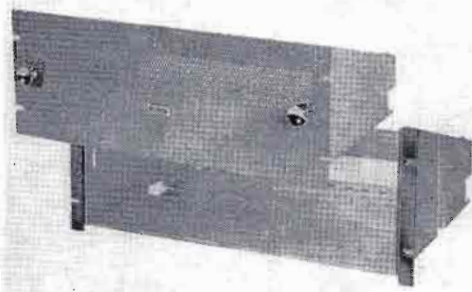

Panel and Shelf Assembly

Is usually used for rack or multiple mounting of plug-in units. Requires only 7"x19" rack space. Front is ventilated by top half being perforated and is instantly removable to allow removing amplifiers from the front, or making gain adjustments. — The BA-20 or BA-21 bases with receptacle, listed below, fasten to the bottom of the panel and shelf assembly. Depth is 13 3/8". Finish medium gloss gray.

Model PAS-1 Panel and Shelf \$22.50

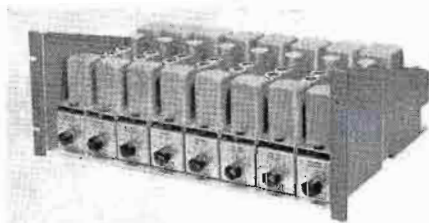

Here are 8 plug-in preamplifiers mounted on one PAS-1 panel and shelf assembly, requiring only 7"x19" of rack space. Self-aligning plugs and receptacles allow unlimited interchange of amplifiers without resetting plugs or receptacles.

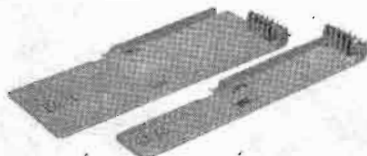

Base and Receptacle

Two bases accommodate all plug-in units. Model BA-20 is for all preamplifiers and the PWR-5 power supply. BA-21 is for program and monitoring amplifiers and PWR-3 regulated power supply. Mounts on bottom of PAS-1 panel and shelf assembly. Where other mounting desired may be secured to any panel, base of desk, or wood cabinet. Supplied with receptacle.

Model BA-20 — Model BA-21

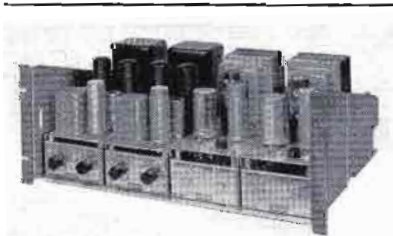

A single PAS-1 panel and shelf assembly will contain a wide variety of combinations. Above are two monitoring amplifiers and two regulated power supplies. This same shelf would hold four preamplifiers, one program amplifier and one power supply, or—two preamplifiers, one program amplifier, one monitoring amplifier and one power supply.

The Plug Is Important In Plug-In

As reliability is the key word in Radio/TV broadcasting, the plug and receptacle are vitally important in plug-in equipment. Picture to right well demonstrates the rugged design, positive contact, good spacing between conductors and the self-aligning feature. You won't break or bend a plug pin with this type of plug-in design.

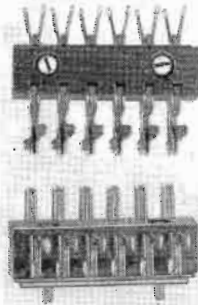

PRICES

Prices on BA-20 and BA-21 bases shown with plug-in items on following pages.

PLUG-IN PREAMPLIFIER

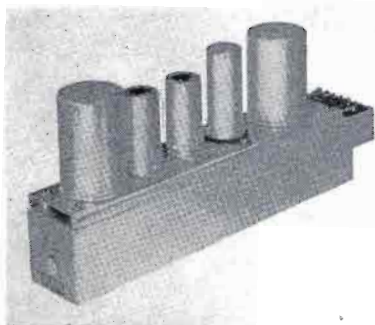

PRE-4 Preamplifier with tubes ... \$63.25
 TK-112 100% Spare tube
 complement 3.50
 BA-20 Base and receptacle 5.25

PRE-4 Preamplifier

GAIN: 40 db \pm 1 db.
DISTORTION: 0.5% or less 50-15,000 cycles. 0.75% or less at 30 cycles. Measured at +8 dbm output.
NOISE: 90 db below +10 dbm output (-120 to -124 dbm equivalent input noise).
LEVELS: Maximum input -32 dbm. Maximum output at above rated distortion, +8 dbm.
IMPEDANCES: Input 150 and 250 ohms. Output 150 and 600 ohms. As input transformer is unloaded, the impedance is substantially higher than source impedance over entire range.
POWER: Requires 6.3 volts AC at 0.3 amperes and 275/310 volts DC at 6 MA.
TUBES: Two type 5879.

CIRCUIT: Two-stage shunt fed output. Overall feedback from plate of second stage to cathode of first stage.

MECHANICAL: Size 2 1/16"x1 1/2"x5 3/8" high overall. Mounts eight in one PAS-1 panel and shelf assembly. One PWR-3 power supply will operate up to 26 preamplifiers; or, one PWR-5 power supply will operate two preamplifiers.

PRE-3 Preamplifier (with variable equalization)

USE: As preamplifier where input transformer is not required, such as with transcription pickups or Hi-Z microphones. Supplied with two external controls and two fixed resistors. When used as straight preamplifier, fixed resistors wired to terminal board. To provide variable equalization \pm 20 db at 100 and 10,000 cycles, variable controls wired in, providing roll-off or accentuation as desired.

GAIN: 40 db \pm 1 db.

NOISE: -70 dbm below +8 dbm output.

RESPONSE: Flat 30-15,000 cycles within +1 db as straight amplifier. \pm 20 db at 100 and 10,000 cycles graduated when used with equalizing controls.

TUBES: Two type 5879.

IMPEDANCES: Input 1/2 meg, output 150 and 600 ohms.

POWER: 6.3 volts at 0.3A and 300 volts at 6 MA.

CIRCUIT: Two-stage shunt fed output with feedback from plate of second stage to cathode of first stage.

MECHANICAL: Same as PRE-4 (above).

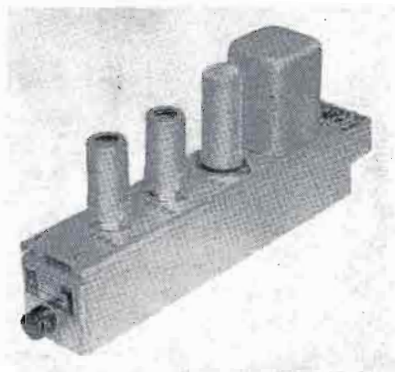

PRE-3 Preamplifier with tubes\$62.25
 TK-112 100% Spare tube
 complement 3.50
 BA-20 Base and receptacle 5.25

PWR-5 Preamplifier Power Supply

For operating one or two PRE-3 or PRE-4 preamplifiers. Usually employed where preamplifier is isolated from main rack such as in turntable cabinet, or where only one or two preamplifiers are used. Supplies 6.3 volts AC at 0.9 amperes and 275/310 volts DC at 12 MA. Uses transformer type supply and extremely well filtered for low noise. Ripple content 0.005%. Tube 6X4.

Model PWR-5 Power Supply\$37.00
 BA-20 Base and receptacle 5.25

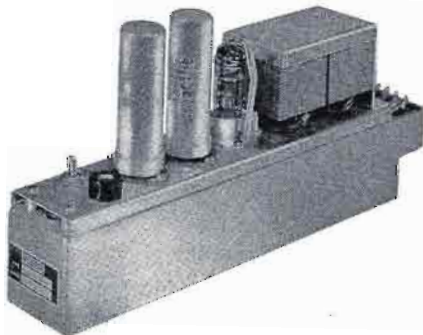

Plug-In Program Amplifier --- Bridging Controls

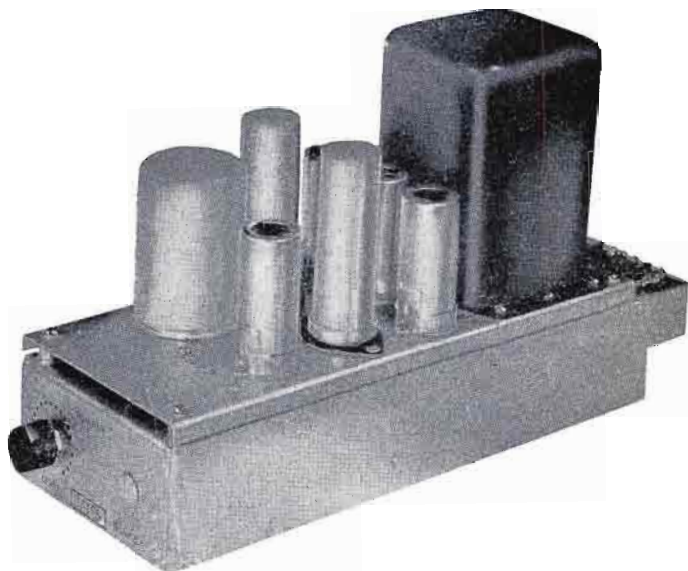

SPECIFICATIONS

USE: As high quality program or line amplifier where output up to +24 dbm at low distortion is desired. One or two of these amplifiers will operate from a single PWR-3 regulated power supply listed on next page.

GAIN: 65 db as a line or program amplifier, direct matching of impedances. Where used as a bridging amplifier with AT2 bridging volume control, the gain is 33 db.

RESPONSE: ± 1 db 30-15,000 cycles.

DISTORTION: 0.5% 50-15,000 cycles. 0.75% or less at 30 cycles.

NOISE: 79 db or better below +24 dbm output with volume control fully open. (-120 to -124 equivalent input noise).

LEVELS: Maximum input +8 dbm. Maximum output +24 dbm.

IMPEDANCES: Input 150 and 600 ohms. Output 600, 150 ohms.

POWER: 6.3 volts AC at 1.05A and 300/330 volts DC at 37 MA.

TUBES: Three 12AU7 and one 5879.

CIRCUIT: Three stages with push-pull output. Feedback between second and third stages.

MECHANICAL: Cold rolled steel chassis, die formed and heavily plated. Size: $4\frac{1}{8}'' \times 11\frac{1}{2}'' \times 6\frac{3}{8}''$ high overall. Type PWR-3 power supply will operate from one to four of these program amplifiers.

PGM-4 Program Amplifier with tubes	\$93.10
BA-21 Base and receptacle	5.50
TK-122 100% spare tube complement	15.35

Bridging Controls

For use with all Gates plug-in amplifiers where bridging input is preferred over direct impedance matching. As all bridging controls insert various degrees of loss in the circuit, this should be taken into consideration. Two high quality carbon controls in tandem, balanced to ground, make up each control. Mounting is external to amplifier.

AT1 Control, 10,000 ohms to 150 ohms	\$6.50
AT2 Control, 10,000 ohms to 600 ohms	6.50
AT3 Control, 20,000 ohms to 150 ohms	6.50
AT4 Control, 20,000 ohms to 600 ohms	6.50
AT5 Control, 10,000 ohms to 150 ohms	6.50

Plug-In Monitoring Amplifier --- Power Supply

MON-4 Monitoring Amplifier

USE: For loudspeaker distribution, recording and auxiliary program amplifiers. High gain allows use with bridging controls or other loss circuits. One PWR-3 power supply and one PWR-10 bias supply, listed below, will operate one or two MON-4 monitoring amplifiers or one monitoring amplifier, one program amplifier and four preamplifiers.

GAIN: As straight amplifier, 103 db. When used with AT2 bridging control, 70 db.

RESPONSE: ± 2 db 30-15,000 cycles.

DISTORTION: 3% or less at +37 dbm with gain control fully open. (Equivalent input noise -120 to -124 db).

LEVELS: Maximum input -27 dbm. Maximum output +37 dbm.

IMPEDANCES: Input 150 and 600 ohms. Output 600, 150, 16, 8 and 4 ohms.

POWER: 6.3 volts AC at 1.5A and 320-340 volts DC at 85 MA.

TUBES: Two each 5879, 6AQ5 and one 12AU7.

CIRCUIT: Four-stage with push-pull output. Tertiary winding feedback from secondary of output transformer to cathode of driver stage.

MECHANICAL: Cold rolled steel chassis, die formed and heavily plated. Size: $4\frac{1}{8}$ "x $11\frac{1}{2}$ "x $6\frac{5}{8}$ " high overall. One PWR-3 power supply, with one PWR-10 bias supply, will operate one or two of these monitoring amplifiers.

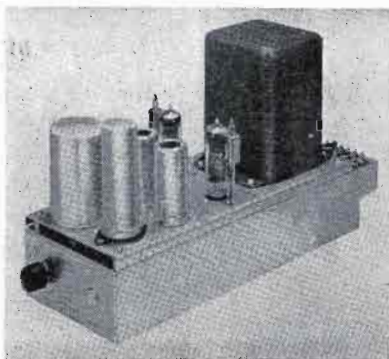

MON-4 Monitoring Amplifier with tubes	\$99.50
BA-21 Base and receptacle	5.50
TK-121 100% spare tube kit	6.50

PWR-3 Regulated Power Supply

USE: An unusually well regulated power supply with very low ripple content. Where used with MON-4 monitoring amplifier, the PWR-10 bias supply should be ordered. Bias supply not required for preamplifiers or program amplifiers.

CAPACITY: Will supply up to 26 PRE-4 preamplifiers, two PGM-1 or four PGM-4 program amplifiers, two MON-4 monitoring amplifiers or any combination of the above.

POWER: Supplies 6.3 volts AC at 8A, 310-350 volts DC at 0-160 MA. With PWR-10 bias unit added, supplies 0-90 volts or low current. For 115 volts, 50/60 cycles. 230 volt design available on special order.

INTERNAL IMPEDANCE: Negligible.

INTERNAL REACTANCE: Negligible.

RIPPLE CONTENT: Less than 0.002 volts or 0.0006% through entire voltage range.

TUBES: One each 5V4G, 5879, 6080; and two OA2.

MECHANICAL: Cold rolled steel chassis, die formed and plated. Hum balance control on filament circuit and voltage output control on front. Size: $4\frac{1}{8}$ " wide, $11\frac{1}{2}$ " front to back, $6\frac{5}{8}$ " high. Mounts four in a panel and shelf assembly.

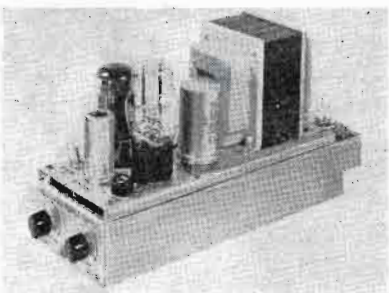

PWR-3 Power Supply with tubes	\$73.90
BA-21 Base and receptacle	5.50
TK-103 100% spare tube kit	11.93



PWR-10 Bias Supply

Plugs into socket provided on PWR-3 regulated supply to provide bias voltage to one or two MON-4 monitoring amplifiers. Not required for preamplifiers or program amplifiers. Where bias supply is used this does not restrict power supply for use with monitoring amplifiers only. Amplifiers may be mixed as desired.

PWR-10 Bias Supply	\$9.25
--------------------------	--------

When Ordering Plug-In Equipment it is necessary to order the BA-20 or BA-21 base/receptacle unit for each amplifier. It is not necessary to order the base/receptacle unit where amplifiers or power supplies are purchased as spares. — All amplifiers are so well shielded that power supplies may be operated on the same panel and shelf assembly with only normal precautions necessary.

Program Amplifier --- Monitoring Amplifier

M-5340 Program Amplifier

This complete program amplifier consists of the PGM-4 plug-in program amplifier listed Page 114, a well filtered permanently mounted power supply, and is completely wired and tested. A modified PAS-1 panel and shelf assembly, listed Page 112, holds the entire equipment and requires only 7" of rack panel space. For performance specifications, see PGM-4, Page 114. — Power supply delivers all necessary filament and plate voltages. Uses a 5V4G rectifier tube. M-5340 illustrated has the gain control on the front of the amplifier, reached by removing the front cover. Models are available, listed below, with gain controls to mount on the front panel identical to the monitoring amplifier shown below.

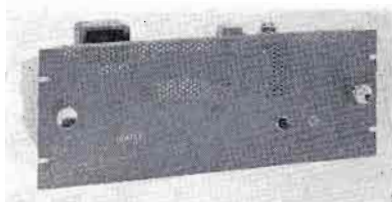

M-5340 Program Amplifier

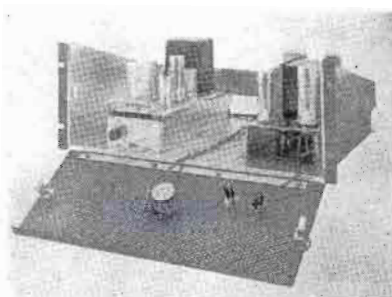

Open view of either Program or Monitoring Amplifier units. Front panel hinges down for quick maintenance. Amplifiers are plug-in type and remove from front.

M-5340 Complete program amplifier with tubes	\$177.50
M-5340A Consists of M-5340 program amplifier with 20 step unbalanced 600 ohm ladder attenuator, dial and knob	183.75
M-5340B Consists of M-5340 program amplifier with 20 step balanced 600 ohm ladder attenuator, dial and knob	203.20
TK-245 100% spare tube kit	6.35

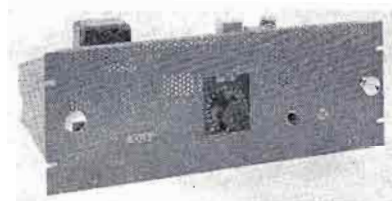

M-5341 Monitoring Amplifier. The M-5340A and M-5340B Program Amplifier appear identical with attenuator front panel mounted.

M-5341 Monitoring Amplifier

Includes the MON-4 plug-in monitoring amplifier listed Page 115, a well filtered permanently mounted power supply mounted on modified PAS-1 panel and shelf assembly—wired and tested. A 100,000 ohm bridging control, mounted on the front panel, allows direct operation across a 150/250 or 500/600 ohm circuit. Gain overall is 70 db. Rectifier tube is 5V4G. For specifications, see MON-4, Page 115. — This model has a wide variety of uses such as a monitoring amplifier, recording amplifier, standby program amplifier, etc.

M-5341 Complete monitoring amplifier with tubes	\$199.00
TK-246 100% spare tube complement	7.85

"Sta-Level" Automatic Program Level Amplifier

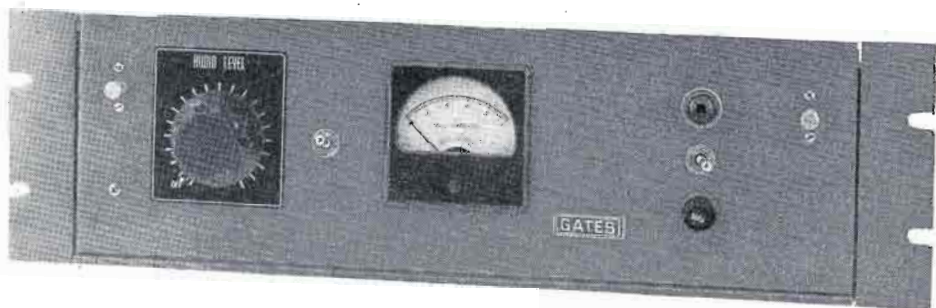

For automatically controlling program level, the Gates "Sta-Level" amplifier offers many improvements both in performance and mechanical design. — A completely self-contained unit, requiring only 5¼"x19" rack panel space with drop-down to service front panel. Included in this single rack mount unit are the "Sta-Level" amplifier, its power supply, compression meter, input and output level controls and Off-On switch.

Outstanding features are:

- Regulated and self-contained power supply.
- 1% or less distortion up to 30 db compression.
- Higher gain, 62 db.
- Special regulator circuit holds threshold of compression constant.
- Compression meter for indicating compression or gain reduction.
- Switch, selects average or dual recovery time to accommodate different modes of operation.

POWER SUPPLY
is standard equipment and not an extra cost accessory in the Gates "Sta-Level".

Though rated at only 1% distortion at 30 db compression, levels of compression as high as 40 db will produce negligible distortion. — Through the ability to raise average program level, the effect is quite the same as increased signal strength at the point of the receiver. The "Sta-Level" should be used with a peak limiting amplifier as it is an average level device and not a peak limiter.

M-5167 "STA-LEVEL" AMPLIFIER

TYPICAL USE: Advantages of the "Sta-Level" are many and varied. As an automatic level device, the "Sta-Level" relieves the operator of most gain riding requirements. — It will automatically adjust for different levels between input channels. Microphones, turntables, projectors, remotes or tapes may be switched in with faders set at normal positions. "Sta-Level" will adjust for sub-normal or at normal gain.

Another common use is where the microphone gain is set higher than turntable gain—the microphone, when switched in will supersede the turntable and automatically fade it. The turntable will return to normal when the microphone is no longer used. — When "Sta-Level" is used with a good limiting amplifier such as the SA-38 or SA-39 on Pages 119-120 it can be said that another generous step forward has been made in automatic programming and better broadcast station performance.

SPECIFICATIONS

GAIN: 62 db at 1000 cycles ± 2 db.

DISTORTION: 1% or less 50-15,000 cycles, 0-30 db compression when using +20 dbm output threshold level.

RESPONSE: ± 1 db 30-15,000 cycles, 0-30 db compression.

NOISE: 65 db or better below output, 0-30 db compression at +20 dbm threshold level.

ATTACK/RECOVERY TIME: Factory wired for average programming. Time constants may be varied by station engineer with chart provided with instruction book.

IMPEDANCES: 600 ohms, input and output.

TUBES: (2) 6V6, (1) 6386, 12AT7, 6AL5, OB2, 543GT.

DESIGN/SIZE: Front panel drops down to reach all inner components. Size: 5 1/4" x 19" x 7" deep. Finish, medium gloss gray. Weight packed, 30 lbs. Cubage, 2.

POWER: 105/115 volts, 50/60 cycles, 50 watts.

ORDERING INFORMATION

M-5167 "Sta-Level" amplifier complete with tubes \$225.00
 TK-243 100% spare tube kit 15.25

The "Sta-Level" may be inserted in the audio circuit in many ways. This sketch shows connection to output of program amplifier in console and moving console VU meter to output of "Sta-Level". Usually "Sta-Level" is at studio as wide dynamic range controls level into the telephone line.

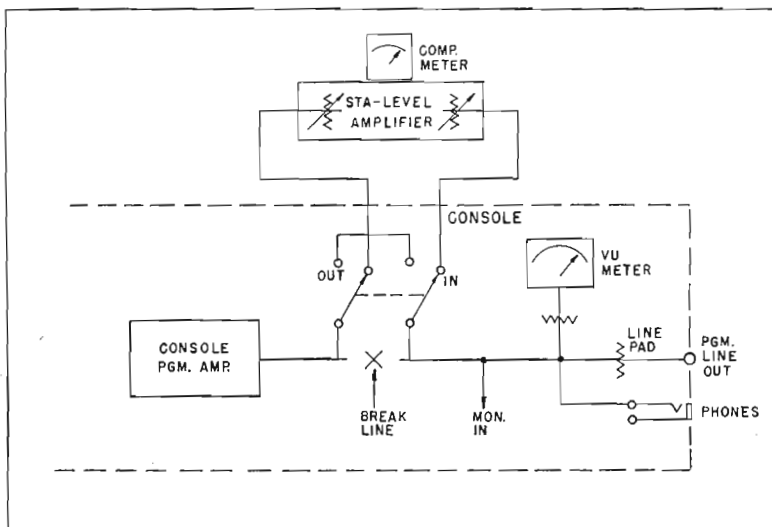

Peak Limiting Amplifier Model SA-38

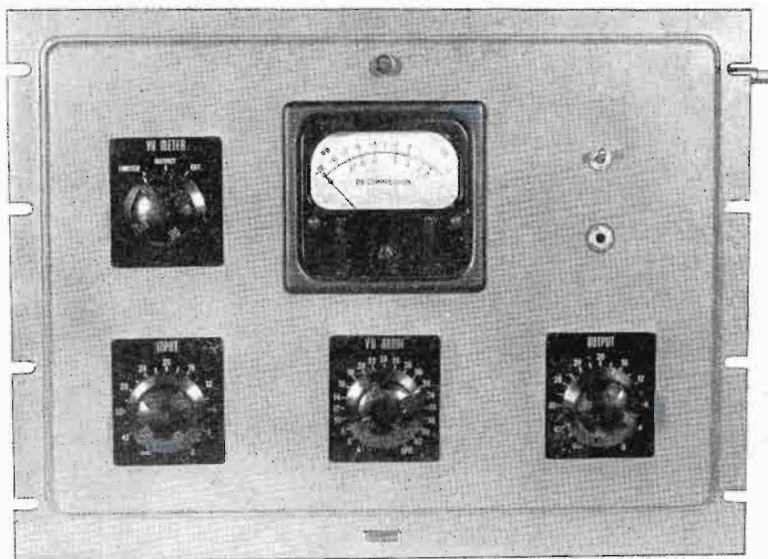

Hundreds of radio and television stations vouch for this fine limiting amplifier. Fast attack time, essentially instantaneous, is completely void of all chirps or thumps. This is because limiting action is obtained by feeding a portion of the output voltage through a full wave rectifier and the negative DC voltage applied to the second control grid of the PP input amplifier tubes. As output voltage increases, the grid becomes more negative, retarding flow of current and lowering the gain of the input stage. The result is unusually high compression with negligible distortion, evidenced by the 1½ % distortion rating at 20 db of compression.

Six switch selectable release times, from 0.2 to 1.2 seconds, are available. — The 4" illuminated meter has VU characteristics, has 2 scales reading: (a) decibels compression, and (b) VU. The meter has an associated range control reading in 2 VU steps +4 to +42 VU. Meter may be selected to: (a) compression, (b) limiter output, and (c) external for proof of performance measurements or any external measurement. Input and output stepped controls are provided.

SPECIFICATIONS

INPUT IMPEDANCE: 500/600 ohms.
OUTPUT IMPEDANCE: 500/600 ohms.
INPUT LEVEL: From -20 VU to +20 VU.
OUTPUT LEVEL: +25 VU or less as adjusted by output attenuator.
MAXIMUM GAIN: 60 db.
RESPONSE: 30 to 15,000 cycles within 1½ db.
DISTORTION: 1½ % or less at all frequencies and up to 20 db of compression.
NOISE: 70 db below any output level.
DIMENSIONS: 19" wide, 14" high, 9½" deep.
FINISH: Medium gray.
POWER SUPPLY: Regulated to plus or minus 5 volts DC, 115 V, 50/60 cycles.
TUBES: Two each 1612, 6V6GT; three each 6SJ7; one each 6H6, 6SSGT, 6Y6G, 5V4G.
SHIPPING DETAIL: Net weight, 38 lbs. Domestic packed, 74 lbs. Export packed, 96 lbs. Cubage, 12.

Front panel drops down to reach all internal components. Ease of servicing is always foremost in Gates designs.

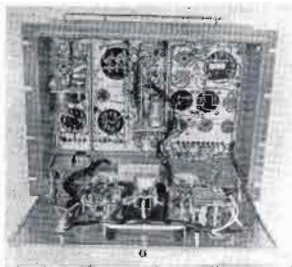

SA-38 Limiting amplifier with tubes\$395.00
TK-150 100 % spare tube complement 16.34

GATES

SA-39 Limiter --- SA-22 Cueing Amplifier

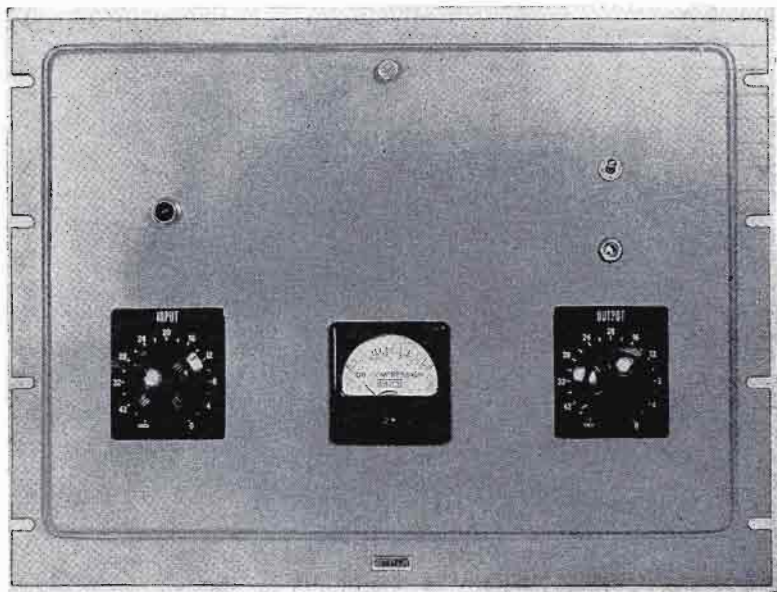

Model SA-39 Limiting Amplifier

Identical in every respect to the Model SA-38 listed on Page 119, except meter indicates "decibels of compression" only. Meter is 3". Where the purchaser has no need for the VU meter feature and associated range control as on the SA-38, this model provides the same electrical, mechanical and performance specifications, and at lesser cost.

SA-39 Limiting amplifier with tubes	\$335.00
TK-150 100% spare tube complement	16.34



SA-22 Cueing Amplifier

A rack mount amplifier with self-contained loudspeaker for independent cueing of turntables, tapes, remotes or any audio circuit. Phone jack provided disconnects speaker when phones inserted. Features drop-down front panel for servicing.



Specifications

TUBES USED:	One each 6SJ7, 6V6, 6X5GT.
INPUT IMPEDANCE:	50,000 ohms, bridging unbalanced.
SPEAKER:	5" PM type.
INPUT LEVEL:	Up to +10 VU.
OUTPUT WATTAGE:	2 watts.
GAIN:	50 db.
RESPONSE:	Including speaker capabilities, 150 to 7000 cycles.
NOISE:	50 db below +30 VU.
POWER REQUIREMENTS:	50 watts from 115 volts, 50/60 cycle line.
SIZE:	19" wide, 8 3/4" high, 9" deep.
FINISH:	Medium gray.
SHIPPING DETAIL:	Net weight, 17 lbs. Domestic packed, 34 lbs. Export packed, 52 lbs. Cubage, 2.9.
SA-22 Cueing amplifier with tubes	\$110.00
TK-151 100% spare tube complement	4.70

VU Panel, Switch-Fuse, Equalizer, Terminal Board



V-22 Volume Indicator

A complete range set with 10 position input selector switch. In this way, all circuits to be measured may be switched in, including proof of performance. Meter is 4" illuminated. Range control in 2 VU steps from +4 to +40 VU. Input impedance 7500 ohms to bridge at 500/600 ohm line. Panel 5 1/4"x19". Finish, medium gloss gray.

V-22 Complete VU range set..\$108.25

Switch and Fuse Panel

Used for turning On-Off all equipment in one relay rack. Two 30A plug fuses mount behind snap-on front panel. Includes indicator lamps and 15A switch. Size: 3 1/2"x19". Finish, medium gray.

M-4242 Switch Panel
\$29.50

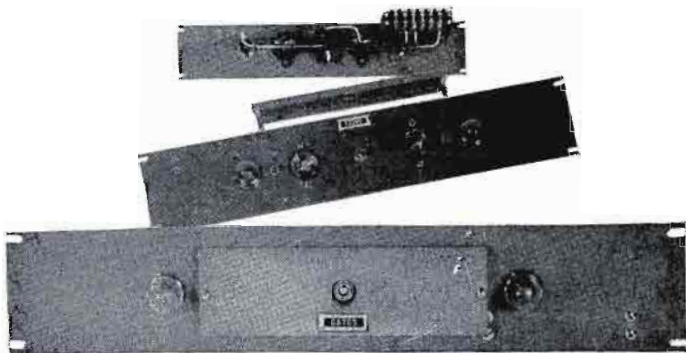

Rack Terminal Board

Provides 80 terminals for inter-rack wiring to base of rack cabinet. A standard PBX item.

Model 46 terminal board \$11.85



Fixed and Variable Equalizers



Model LE-1

MODEL LE-1: Shown to left is a fixed equalizer. Curve is to bottom left of page. A parallel resonant circuit operating with either a 150 or 600 ohm line. Equalization is varied by means of self-contained resistors in 1 ohm steps up to 111 ohms. Inductance is tuned by 0.05 mfd and 0.025 capacitors, also self-contained. Size: 2 1/2"x2 1/2"x3". Ideal for equalizing telephone lines or any circuit requiring correction.

LE-1 Fixed equalizer \$23.00

LE-2 VARIABLE EQUALIZER: Illustrated above, consists of the LE-1 equalizer with two variable controls, inserting the resistance in 1 ohm steps up to 111 ohms as required for full equalization. A double jack input is provided for direct parallel patching. Provision is also made for mounting a variable attenuator, sometimes desired in controlling line level. Panel size: 19"x3 1/2". Finish, medium gray. Use curve to left for equalization data.

LE-2 Variable equalizer \$86.00

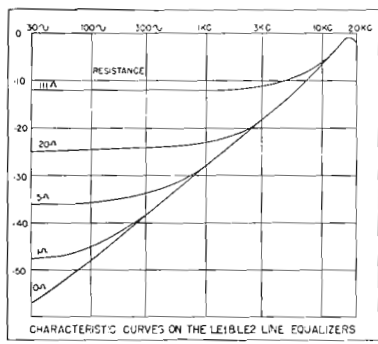

4 STOCK CARRYING POINTS

Atlanta, Georgia; Houston, Texas; Los Angeles, California and the main factory and warehouse in Quincy, Illinois. Consult the front pages of this catalog for phone and TWX numbers.

AUDIO PATCH PANELS AND CORDS

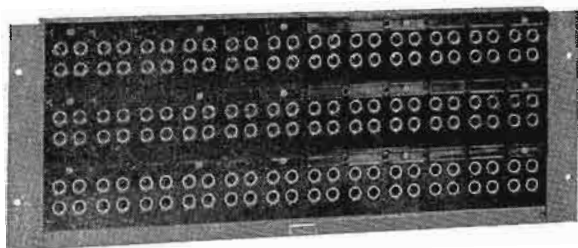

Left, three C-1500 jack panels mounted on PD3 jack mat. Has 144 jacks (72 pairs). Panel size: 7"x19".

Right, two C-1500 jack panels mounted on PD2 jack mat. Has 96 jacks (48 pairs). Panel size: 5 1/4"x19".

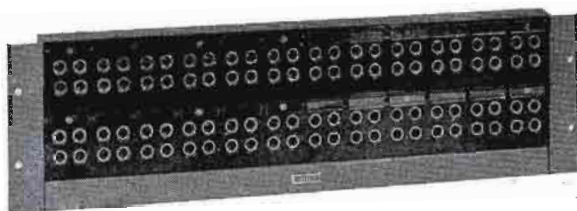

Left, one C-1500 jack panel mounted on PD1 jack mat. Has 48 jacks (24 pairs). Panel size: 3 1/2"x19".

C-150 jack panel has 24 jacks (12 pairs). Size: 1 3/4"x19". Does not require jack mat. End brackets for rack mounting supplied.



Patch cords available in four lengths. Double plus each end. Shielded and covered with durable black braid plus extra reinforcement 6" from each end.



Patch Panels

Industry standard double patch assemblies. Jack strips listed separately from jack mats for ease in ordering. All jacks closed circuit type for normalizing through audio circuits. Non-aging, non-ferrous metal assures long lasting spring tension. Contacts of silver alloy. Jacks held by molded bakelite, steel reinforced. Individual designation strips with slip-in holders for each pair of jacks.

C-150 jack strip (24 jacks) with mounting brackets.....	\$29.00
C-1500 jack strip (48 jacks) less mat	46.00
PD1 jack mat for one C-1500 jack strip	7.25
PD2 jack mat for two C-1500 jack strips	7.25
PD3 jack mat for three C-1500 jack strips	7.25
PJ12 patch cord 2' long	7.80
PJ13 patch cord 3' long	7.98
PJ14 patch cord 4' long	8.28
PJ15 patch cord 5' long	8.52

SOUND EFFECTS WAGON

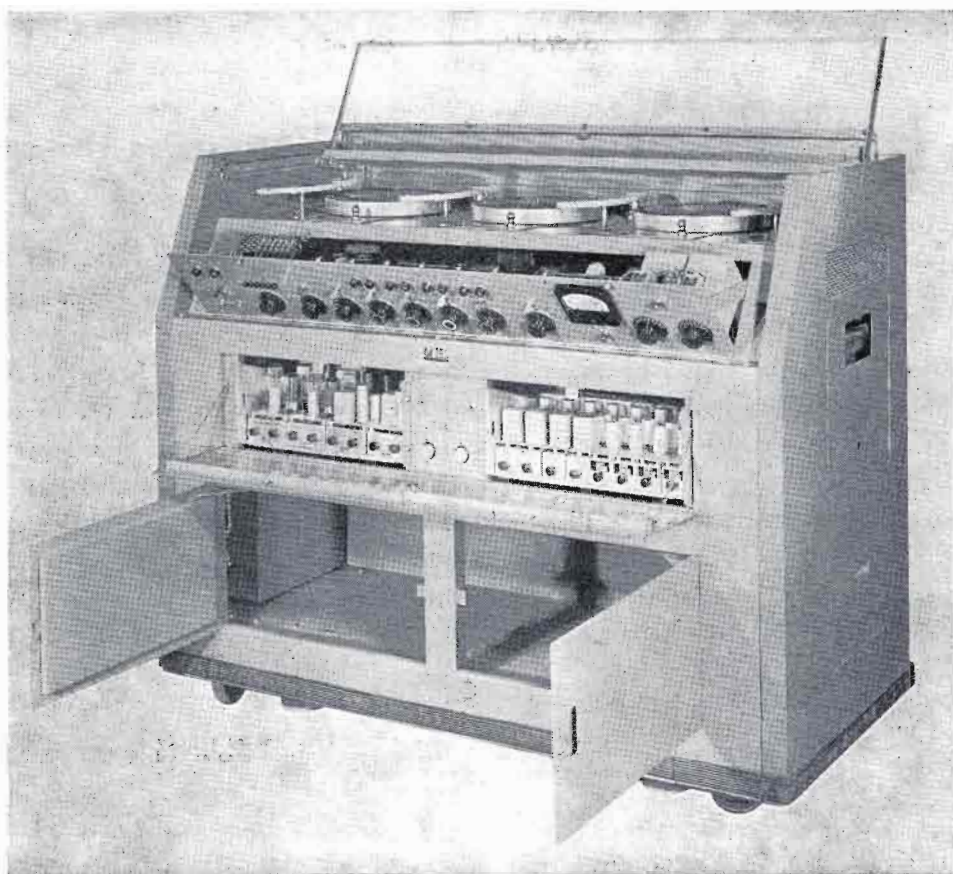

In program production, the sound effects wagon plays a very important part. The CSE-9 sound effects console has been designed to provide the sound department with a unit having every modern feature, handling ease, and the same quick serviceability, in case of trouble, that will be found in any modern up-to-date speech input system.

Study of the functional diagram on Page 125 will disclose a great amount of detail. Six input circuits, two for microphones and four for pickups, feed into a program amplifier as well as a power amplifier. Each of these six channels has ladder attenuators with cue position at infinity. This cue output feeds into a split headphone arrangement. Four circuits are handled: (1) program cue, (2) sound effects cue, (3) sound effects out, and (4) director's cue. The two microphone channels are provided with PRE-4 plug-in preamplifiers, and the

(continued next page)

MOBILE SOUND EFFECTS EQUIPMENT

four pickup channels are provided with PRE-3 preamplifiers with high and low roll-off, described on Page 113. In addition to individual equalization of each pickup, a master sound effects filter is provided, with complete high and low roll-off. — It can be said with accuracy that nearly any type of response curve may be obtained to provide the effect desired.

Turntables are adjustable to any speed from 25 to 100 RPM. Standard speeds of $33\frac{1}{3}$, 45 and 78 RPM are identified. Turntables are rim drive. Each transcription arm is provided with spotting light. Each turntable will accommodate two transcription arms for continuous effects. — All amplifiers and power supplies are of the plug-in type. Knobs for attenuators and key switches are color coded for easy identification. Terminations are made to receptacles located on both sides of the cabinet. Cabinet is rigidly constructed of light metals to assure easy mobility on the silent rubber-tired wheels that may be locked in place for permanence. Bottom section of cabinet is for storage. Front control panel hinges down for servicing. When not in use, the plexiglass copy stand (illustration below) pulls up and over the turntables and control panel.

When closed, the plexiglass copy stand folds down and a metal top slips up from the back and drops over the top for full protection of turntables and pickups. Silent rubber-tired, ball bearing wheels allow quiet mobility during programming.



SOUND EFFECTS WAGON CSE-9

LSB-2 dual speaker assembly on the mobile dolly along with the high output power amplifier in the CSE-9 sound effects wagon, allows tremendous dynamic range and high volume, if required. At the same time, the fine Hi-Fi characteristics of the entire system assures the best possible background music effect in certain types of productions. The ability to obtain any response curve adds to both mechanical and musical sound effects.

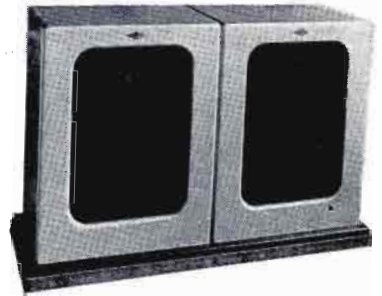

Dual loudspeaker on mobile dolly, type LSB-2

SIZE OF CSE-9 SOUND EFFECTS WAGON: 60" wide, 27½" deep, 48" high overall.

SIZE OF LSB-2 SPEAKER DOLLY: 60" wide, 18" deep, 36" high overall.

POWER: 115 volts, 50/60 cycles, approximately 400 watts.

WEIGHT PACKED: 400 lbs. Cubage, 75.

ORDERING INFORMATION

Model CSE-9 sound effects wagon complete with tubes, less loudspeakers	\$4995.00
Model LSB-2 dual loudspeaker assembly	358.00
TK-155 100% spare tube complement	66.40

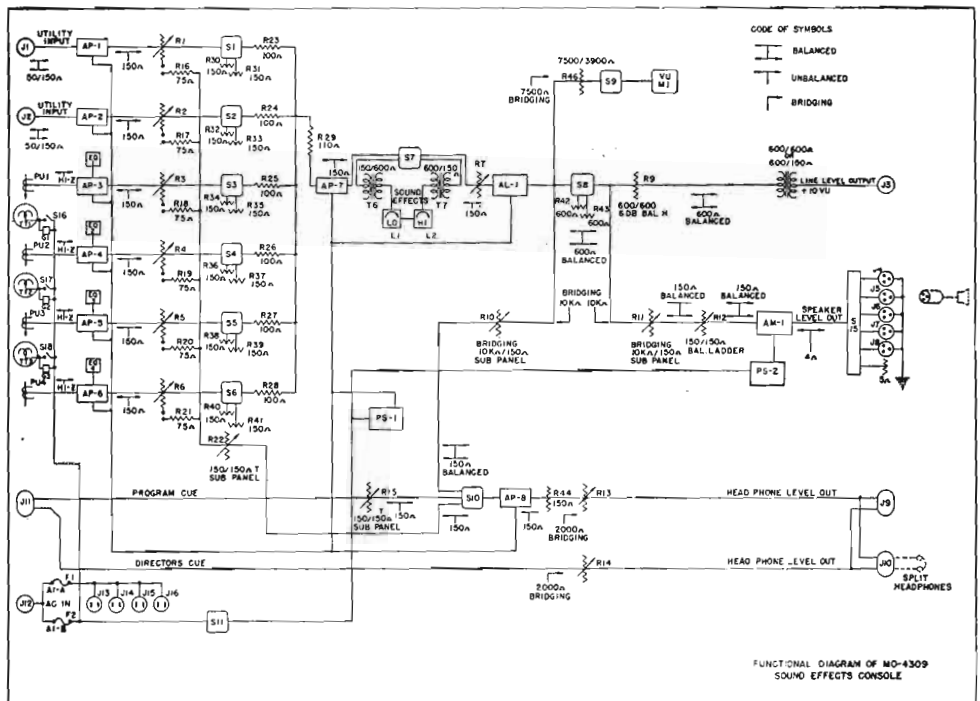

AUDIO EQUALIZERS---SOUND EFFECTS FILTERS



Four SA equalizers on 19" panel

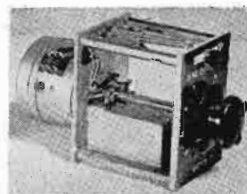

Single SA equalizer

A precision equalizer available in 5 ranges as listed below. Has twenty 1 db steps. Consists of a high Q coil capacity tuned. Dual frequency units have selector key for each frequency. Dial indicates equalization in decibel variance from 1000 cycles. Several equalizers may operate in parallel without affecting the other. For operation across a 500/600 ohm circuit. Dial in black anodized. Easily panel mounted. Curve below is that of SA-118 for 4000 and 6000 cycle equalization.

Cat. No.	Equalizer Frequency	Price
SA-116	30 cycles	\$67.70
SA-117	Dual, 50 and 100 cycles	72.45
SA-118	Dual, 4000 and 6000 cycles	70.00
SA-119	Dual, 8000 and 10,000 cycles	53.25
SA-120	15,000 cycles	44.45
SA-121	Panel to mount four SA equalizers	12.00

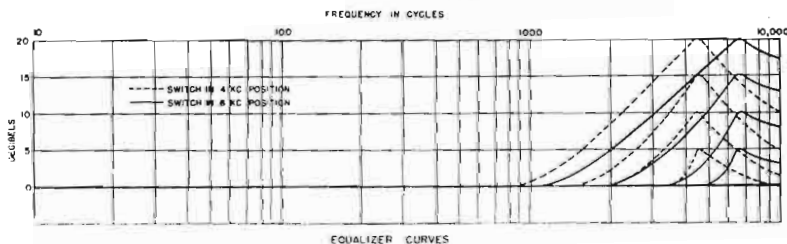

Typical curve of SA-118 equalizer for 4000 and 6000 cycles.
Other frequencies are similarly covered.

Sound Effects Equalizers

Ultimate in sound filters. Features wide frequency spectrum with overlapping cut-off frequencies, zero phase distortion, clickless steps of control, inductances toroidally wound and complete shielding for absence of hum pick-up. Input level -70 to +28

dbm. Insertion loss, zero. Circuit constant, K. Available in two types: (a) low frequency cut-off, 10 positions of 70, 100, 150, 250, 500, 1000, 2000, 3000, 5000 and 7500 cycles, (b) high frequency cut-off, 10 positions of 300, 500, 1000, 2000, 3000, 5000, 6000, 7000, 8000 and 10,000 cycles. Provided with dial. Panel mounting. Size: 3 1/4" x 3 1/4" x 5" deep.

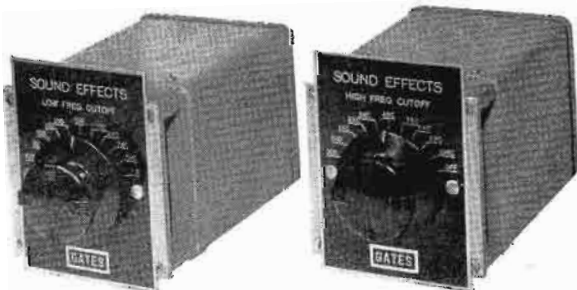

FSE-1 High frequency cut-off	\$174.00
FSE-2 Low frequency cut-off	174.00

DESKS FOR AUDIO EQUIPMENT



Desk For Speech Consoles

Designed for use with the Gatesway, Dualux and M-5301 TV consoles on Pages 88, 94 and 106, but may be used with other consoles as well. Has non-staining black micarta top molded to 7-ply seasoned birch. Sides and back of 16 gg furniture steel finished in hand rubbed gloss gray. Leveling feet are provided at the four corners. Size: Top 39 $\frac{3}{4}$ " wide, 32" deep. Height 29" \pm 1" by leveling screws.

CB-6300B Desk \$137.95

Linoleum Top Console Desks

A modest priced, highly attractive desk that may be used with any Gates console and other consoles up to 48" in width. Top 5-ply seasoned birch, covered with black heavy grade linoleum with style strip around edge. Sides and back of 16 gg furniture steel finished in hand rubbed gloss gray. Leveling screws provided on all four corners. Chair and console illustrative only. Two sizes available. Both vary in top (front to back size) only. Height 29" \pm 1" for leveling screws. Width 48". CB-62A, front to back, 26". CB-63, front to back, 32".

CB-62A Desk \$85.00

CB-63 Desk 87.50

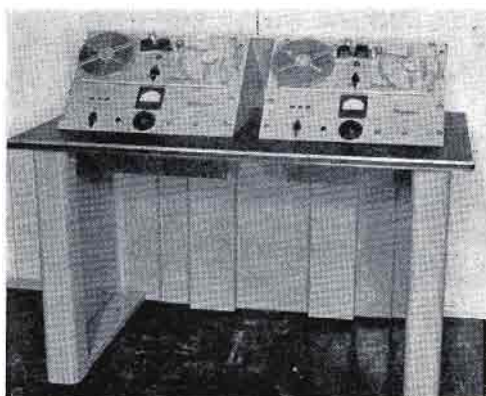

Desk With Rack Angles

A popular model that permits desk operation of conventional rack mount equipments such as tape recorders, receivers, control equipment for transmitters, mixers, audio amplifiers, etc. Panels slope at 45° angle. Top is provided to cover rack mounted equipment. Provides two 19"x14" spaces. Blank panels may be used where less space required. Desk top is cut out to allow for rear slope of equipment. Top 5-ply seasoned birch with heavy black linoleum covering and style trim around edge. Sides and back of 16 gg furniture steel finished in hand rubbed gloss gray. Leveling feet provided on all four corners. Size: 48" wide, 29" high \pm 1" for leveling and 26" front to back. Recorders are illustrative only.

CB-62 Desk with angles and top cover \$97.50

NOTE: Special rack or dimensional sizes of the CB-62 desk is not economically feasible as price is determined by quantity production.

CB-4 HORSESHOE DESK

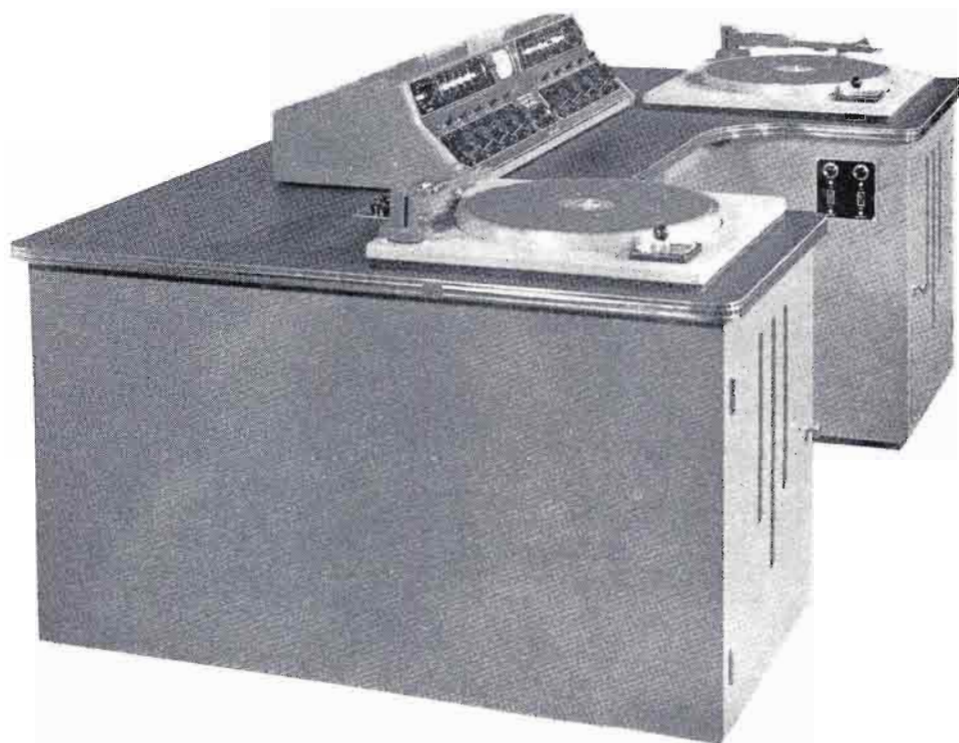

Often referred to as the most beautiful speech input accessory ever designed for the broadcast industry. — Even though wonderfully attractive, CB-4 is even greater in its functional usefulness. — Here the turntables are on each side of the operator at the correct arm's length for relaxed operation. The speech input console seems to have even control at the very fingertips. Inside of each wing, again at fingertips, are the two silent turntable starting switches.

Right and left wings are big and roomy. Designed with enough width to hold 19" rack panel equipment, but used just as frequently for the day's transcribed programs. Actually, there is more than enough room for both. — Here, indeed, is a show piece both in massive, eye-catching appearance and engineering correctness. Many broadcasters found the slight extra cost paid big dividends in better broadcasting through operator's pride in knowing he has the finest.



CB-4 Desk---Complete Packaged Speech Systems

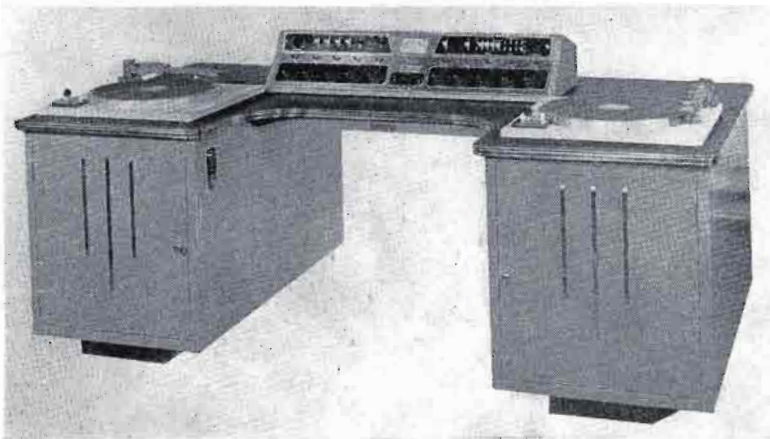

Specifications

CONSTRUCTION: Top of seasoned 7-ply selected birch covered with double thick black linoleum. Top edge is banded with a chrome style band fitting flush. Top is secured to two end wings having inside dimension of 22½" wide, 25" high and 45" deep. Each wing has a removable rear door and hinged front door. Wings are of seasoned plywood (selected birch) and will not warp or check. Each wing will accommodate 21" of 19" rack panel space. Wings may be used for disc or tape storage on one or both sides.

FINISH: Medium gray smooth lacquer presents metal finish. Use of wood is for best turntable performance as well as appearance. Top is black. Trim is chrome.

WIRED MODELS: In wired models the desk is cut out for Gates CB-100 turntables on each side. Mercury type TT motor starting switches are provided on the inside of each wing. An additional master switch is provided on the inner right wing. Wiring is terminated to the rear base, including terminals for preamplifier.

OTHER ACCOMMODATIONS: Most types of turntables and nearly all types of speech input consoles may be used with the CB-4 desk. Size is such that consoles of substantial width and depth may be employed without sacrifice of arm room or serviceability of console.

WEIGHT: Packed, 390 lbs. Cubage, 120.

CB-4 Desk Combination

CB-4 Desk only without cutouts or wiring	\$ 350.00
CB-4M Desk only with cutouts for CB-100 turntable, switches and wired	375.00
CB-4N Desk with two CB-210A turntables listed Page 134, wired, includes preamplifiers	978.00
CB-4P Desk with CB-100 turntables, Gray 106-SP arms, Gray 602C equalizer, dual cartridge, 1 mil. and 2½ mil. diamond stylus, wired ..	1003.78
CB-4R—Includes CB-4N listed above with Gatesway speech input console (illustrated above) and fully described Page 94	2273.00
CB-4S—Includes CB-4P listed above with Gatesway speech input console (illustrated above) and fully described Page 94*	2298.00

NOTE: CB-4 desks may be used with any Gates console. Select desk combination of your choice and add console price for total selling price.

* Does not include preamplifier for turntables. Order SA-134 listed Page 138.

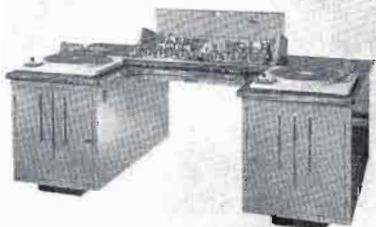

GATES

129

MASTER PRESET CONTROL CONSOLE



Large studio installations involving many control points and several outgoing circuits are usually best suited to master control. — As technical requirements vary from one installation to another, no particular attempt is made to offer the broadcaster a standardized type of master preset equipment. However, by reason of the generous number of preset installations that have been designed and furnished by Gates, it is relatively simple to adopt standard procedures to the custom requirements of the customer. — Gates engineers will gladly confer at any time with those interested in more complex studio equipment requirements.

The preset unit, illustrated herein, is based around a parallel preset relay system. Divided into three sections, ten relays in each unit are employed for program switching and are preset from the front panel. These relays are then controlled by a master relay. A double light bank indicates the preset circuit. Red is "On Air". Green is "Preset". The lever key locks up to "Master" and is non-locking down to "Operate".

It will be noted that though complete in every detail, the space requirements are held to a minimum as can be observed by comparing the 4" VU meter size to the total width and height. Prices on Preset equipment will be gladly supplied in accordance with station needs.

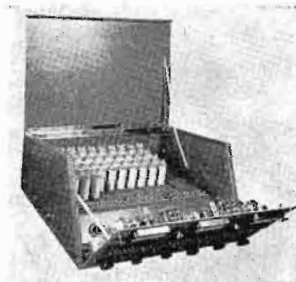

COMPLETE TRANSCRIPTION TURNTABLES



Two complete 3-speed turntables offer the radio and television broadcasters the finest. Both incorporate the CB-100 turntable chassis, described on next page. Cabinet only is also available.

Equalizer provides four response positions: (1) flat, (2) intermediate, (3) NARTB-AES curve, and (4) roll off of highs for records with high surface noise. Output impedance 150 ohms. Output level approximately -66 dbm.

CB-150 TURNTABLE includes mechanism with Gray 108B viscous damped arm, 602C variable equalizer, dual slip-on pickup cartridges equipped with 1 mil. and $2\frac{1}{2}$ mil. diamond stylus, wired and ready to use.

CB-160 TURNTABLE includes mechanism with Gray 106-SP arm, 602C variable equalizer, single pickup cartridge, $2\frac{1}{2}$ mil. stylus (1 mil. stylus optional), wired and ready to use.

CAB-6 CABINET only, made of heavy 5-ply cabinet makers' prime seasoned birch, sealed, finished in medium gloss gray with center trim in black. Four leveling screws and full size back door provided. Size: $29\frac{1}{2}$ " high, $21\frac{1}{4}$ " square.

CB-150 turntable complete	\$457.50
CB-160 turntable complete	423.00
CAB-6 cabinet only	90.00

TRANSCRIPTION TURNTABLE CB-100



A new professional 3-speed turntable capable of unusual speed accuracy, low rumble and incorporating fingertip control of both speed change and motor starting. — Direct control of speed shifting, eliminates springs, multiple drive wheels or gravity systems of speed change. Chrysler oilite bearings are used at all rotating points while Monoball self-aligning bearings are employed in the speed changing mechanism.

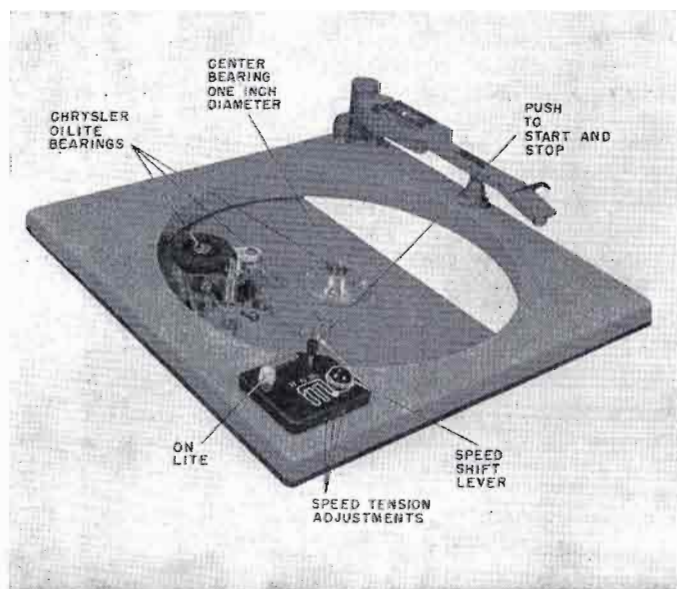

TRANSCRIPTION TURNTABLE CB-100

SPECIFICATIONS

CHASSIS SIZE: 21 1/4" x 21 1/4" x 3".

MOTOR HANG BELOW BASE: 8".

CONSTRUCTION: Both base and platter of cast machined aluminum.

FINISH: Gray ripple enamel with turntable top cover of green felt.

STROBOSCOPE: Inbuilt on platter.

CENTER HUB: Spring locking type snaps up instantly for larger 45 RPM hub; locks down for standard records and transcriptions.

CENTER BEARING: 1" diameter hardened steel shaft fits into bronze Chrysler oilite bearing.

MOTOR: Synchronous, capacitor start, dynamically balanced, neoprene shock mounted 1/75 H. P.

CUE ALLOWANCE: 1/6 turn at 33 1/3 RPM, 1/3 turn at 45 RPM, 1/2 turn at 78 RPM.

NOISE: 40 db or better below average sound track.

MOTOR START: Single switch, push to start, push again to stop; neon light indicates on cycle.

IDLER WHEEL: Special shear action neoprene self-aligning with Chrysler oilite center bearing.

SPEED CHANGE: Direct single control of vertical action of drive wheel with detents.

POWER: 115 volts, 60 cycles, 45 watts. 50 cycle also available.

CB-100 Transcription Turntable \$185.00
CB-100A Same as above but for 50 cycles 195.00

Below: Exploded view of the rugged and accurate construction of the CB-100 turntable.

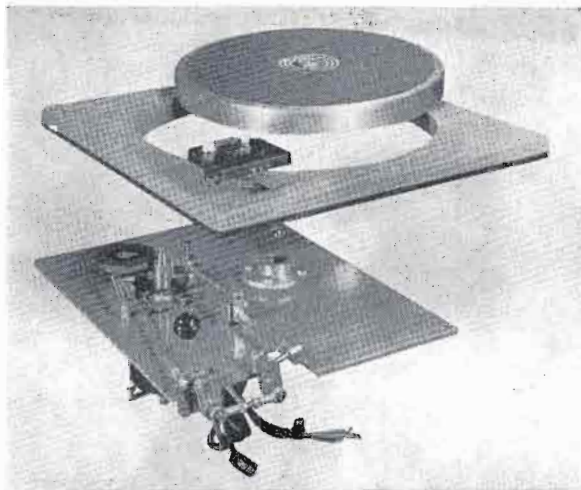

TRANSCRIPTION TURNTABLE CB-210



Here is a complete 3-speed commercial turntable including self-contained pre-amplifier, power supply, pickup arm, dual cartridge and dual styli and very modes in price. Will fit in CAB-6, CB-15 cabinets, CB-4 desk, or any suitable desk arrangement.

SPECIFICATIONS

TURNTABLE: Model CB-100, described on preceding page.

PICKUP ARM: Livingston Universal for all discs up to 17".

PICKUP CARTRIDGE: GE, including dual 1 mil. and 3 mil. styli, diamond or sapphire as ordered.

PREAMPLIFIER: Equalized type mounts directly to base of turntable chassis. Selenium type power supply self-contained. Distortion: $\frac{1}{2}$ % 50-15,000 cycles at -10 dbm output. Output impedance: 150/600 ohms. Noise: 65 db. below -20 dbm. Gain and hum balancing controls self-contained. Tubes: (2) 12AX7. Equalizer switch provides 3 curves: (1) NARTB, (2) RIAA* and (3) high frequency roll off for worn records. For 115 volts, 60 cycles.

*RIAA is very newest standard adopted by Record Industry Association of America.

CB-210 (M-5251) with dual sapphire styli	\$275.00
CB-210A (M-5251A) with dual diamond styli	301.50
CB-225 includes CB-210 with CAB-6 cabinet	365.00
CB-225A includes CB-210A with CAB-6 cabinet	391.50

NOTE: CAB-6 cabinet listed on page 131. For 50 cycles add \$10.00 to all models.

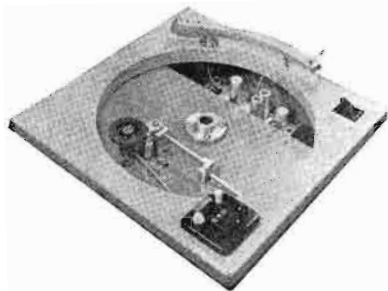

What is supplied in the CB-210:

- 1 CB-100 turntable chassis.
- 1 Livingston Universal arm.
- 2 GE styli for 1 and $2\frac{1}{2}$ mil.
- 1 GE dual pickup cartridge.
- 1 Equalized preamplifier with tubes and self-contained power supply.
- 1 Arm rest.
- 1 Equalizer switch with plate.

PRESTO TURNTABLES



Model 64-A

Available in both dual and 3-speed models, the Presto 64-A turntable has long been considered one of the excellent direct drive units. Standard equipment includes cabinet and mechanism. Size of cabinet: 24" square, 30" high. May be used with any conventional pickup, listed elsewhere in this catalog section. For 115 volts, 60 cycles.

64-A Turntable, 33 $\frac{1}{3}$ and 78 RPM \$585.00

64-A3S Turntable, 33 $\frac{1}{3}$, 45 and 78 RPM 717.00

Extra for drilling and mounting
reproducer (any kind) 17.00

Model 10-B

Consists of chassis, 16" turntable, motor and 3-speed drive mechanism. Drive consists of motor and pulley which directly contacts a rubber tire set into a groove around the outer rim of the turntable. For 115 volts, 60 cycles.

10-B Turntable \$249.00

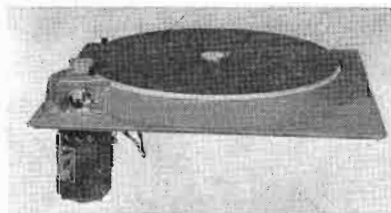

Model T-68

3 speeds, 15 $\frac{3}{4}$ " turntable and designed straightforward for highly effective results. Available with shaded pole or hysteresis motor, latter suggested for commercial application. Operates at all 3 speeds with single speed shift lever. For 115 volts, 60 cycles.

T-68 Turntable with shaded pole
motor \$ 79.50

T-68H Turntable with hysteresis
motor 134.00



Model T-18

Similar to the T-68 above but has 12" turntable. Operates at all 3 speeds with single shift lever and triple idlers. Available with either shaded pole or hysteresis type motor. For Hi-Fi or broadcasting where a 12" turntable is sufficient.

T-18 Turntable with shaded pole motor ...\$ 53.50

T-18H Turntable with hysteresis motor 108.00



PRESTO --- FAIRCHILD EQUIPMENT

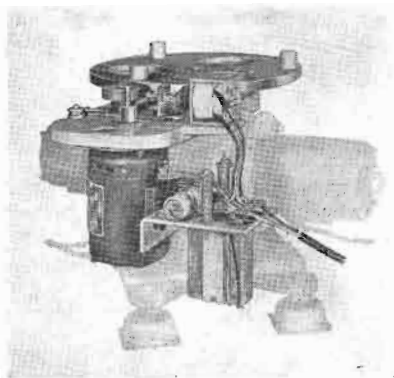

TA-1 Adaptor

There are many of the Presto 64-A two-speed turntables in use. This unit converts the 64-A to a 3-speed unit, or adds 45 RPM. Includes everything necessary such as motor, mounting plate, start switch and complete instructions.

TA-1 Adaptor Unit \$132.00

TA-2 Adaptor Kit

Contains all necessary parts to add 45 RPM to the Presto 10-A transcription turntable, including new speed shift plate, adaptor disc, motor pulley, stop bracket and switch bracket.

TA-2 Adaptor Kit \$22.00

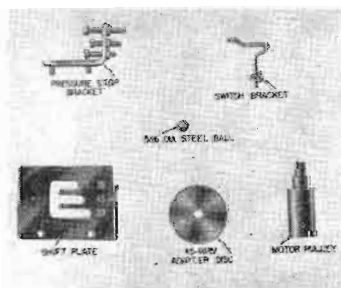

Fairchild Model 530

A professional 3-speed, direct drive transcription turntable with cabinet. Uses fully synchronous hysteresis motor. Maker states rumble, noise and vibration virtually non-existent. Features fast cueing and absolute timing. Cabinet size: 24" square and 26 1/2" high. With turntable height 28". Finish: light gray. Suggested pickups listed elsewhere in this catalog section.

Model 530 Fairchild Turntable \$530.00

Rek-O-Kut Cueing Adaptor

For 45 RPM. Fits spindle of any turntable. Consists of machined cast aluminum disc with built-in hub for 45 RPM records. Top face is partially felt covered, the area coinciding with the record label being uncovered so record lays flat without slippage. Design allows easy cueing of 45 RPM records.

RK-45G Cueing Adaptor \$6.95



REK-O-KUT TURNTABLES



3-speed, 16-inch

A fine commercial turntable for all three speeds and for records of all sizes including 16". Motor: hysteresis type synchronous. Has retractable hub for 45 RPM. Size: 18 3/4"x20" with height above chassis 1 1/2" and below chassis 6 1/2". Shipping weight, 30 lbs. For 115 volts, 60 cycles.

Model B-16H Turntable \$250.00

3-speed, 12-inch

With the advent of smaller diameter discs, the 12" professional turntable is gaining in popularity. This is one of the best with 3 speeds, hysteresis synchronous motor, very low noise, flutter and wow. Retractable hub for 45 RPM. Size: 15 3/4"x14" with 1 1/2" above and 6 1/2" below chassis. Shipping weight, 16 lbs. For 115 volts, 60 cycles.

Model B-12H Turntable \$129.95



2-speed, 12-inch

A modest priced turntable for Hi-Fi or intermediate broadcast duty. Retractable 45 RPM hub. Has 4-pole induction motor. Heavy dynamically balanced aluminum platter. Available for either 45-33 1/3 RPM or 78-33 1/3 RPM. Size: 12"x15" with 1 3/8" above and 5" below chassis.

Model L-34 (45-33 1/3 RPM) \$49.95
Model L-37 (78-33 1/3 RPM) 49.95

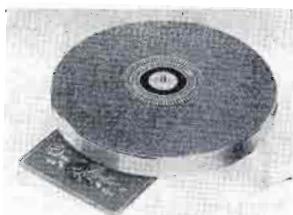

Continuously Variable

Plays all speeds from 25-100 RPM. Direct indicating dial shows operating speed. Ideal for sound effects as well as many special applications of music instruction. Turntable 12". Size: 16"x12" with 1 1/2" above chassis and 5" below. 4-pole induction motor for 115 volts, 60 cycles.

Model CVS-12 Turntable \$89.95



Turntable Cabinet for B-16H

Designed for use with B-16H turntable at top of page. Has dual storage compartments with piano hinge doors and flush ring latches. Includes inbuilt electrical outlets and adjustable leveling casters. Size: 33" high, 22" wide, 20 1/2" deep. Finish, gray.

Model C-7B Cabinet only \$115.00

TURNTABLE ACCESSORIES

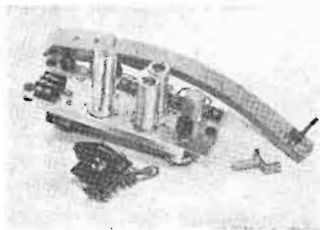

Pickup-Amplifier Kit

Consists of Livingston Universal arm with GE RPX-050 dual cartridge, dual sapphire 1 mil. and 2 1/2 mil. styli, arm rest, equalized preamplifier, equalizer switch and plate and ready to attach to your turntable. Preamplifier has self-contained selenium power supply for 115 volts, 50/60 cycles. See CB-210 turntable for performance specification.

Model M-5266 pickup-amplifier kit \$90.00

Desk Top Turntable Cabinet

Designed to hold either CB-100 or CB-210 turntable chassis. Made of 16 gg. steel, undercoated, finished in medium gloss gray, and supplied with leveling screws. Has plastic style trim around top. Size: 21 1/4" square and 6 1/2" high.

Model CB-15 cabinet \$25.00



Turntable Preamplifier

The famous Gates SA-134. Thousands in use. 3 stages with self-contained power supply. Suggested for CB-150 and CB-160 complete turntables. Input 50/250 ohms. Output 600 ohms. Gain 82 db. Response $\pm 1\frac{1}{2}$ db. 50-15,000 cps. Noise 65 db below -10 dbm. Distortion 1% or less at 0 dbm. Tubes: 6J7, 6SJ7, 6SN7, 6X5. Size: 17 1/4" long, 5 1/8" wide, 5 1/2" high. May be mounted flat or on 5 1/4"x19" rack panel. For 115 volts 50/60 cycles. Includes locking gain control, fuse, output jack and Off-On switch.

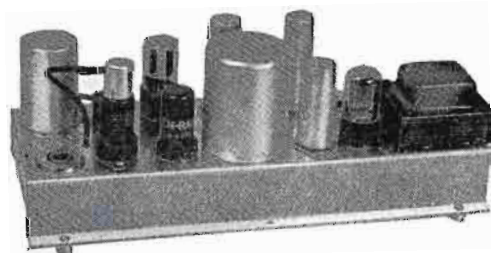

Model SA-134 amplifier with tubes \$78.00
Spare 100% tube kit M-3961 3.68

Equalized Preamplifier

Used in CB-210 and M-5266 kit listed top of page. See specifications listed under CB-210 turntable. Supplied with 3-position filter switch and plate, not illustrated. Approximate input impedance 5000 ohms, depending on filter switch position. Designed for use with GE cartridges RPX-040A through RPX-063A. Power supply self-contained for 115 volts 50/60 cycles.

Model M-5235 amplifier \$56.50
Spare 100% tube kit T-225 2.30

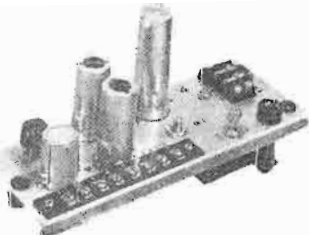

Stylus Force Gauge

For measuring pressure of stylus on record. An inexpensive unit that should be wherever turntables are used. Assures correct stylus pressure for best quality and minimum record wear.

Model 301 stylus gauge \$1.50

PICKUPS — EQUALIZERS

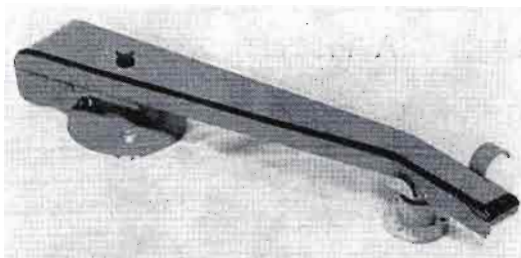

Viscous-Damped

Perfect record tracking, no groove jumping, adjustable dampening, prevents damage due to dropping, cartridges changed instantly, automatic correct stylus pressure, for records up to 16"—the very finest in transcription arms. Recommended for use with Pickering or the new GE cartridge. Made by Gray Research.

Model 108-B (arm only) .. \$56.00
Model 108-C (arm only) ... 39.95

Gray 106-SP

One arm for all speeds up to 16" records, quick cartridge change, resonance below standard recording limits, precisely adjustable stylus pressure, adjustable pivot height. Supplied with 3 cartridge slides for GE or Pickering cartridges.

Model 106-SP (arm only) \$45.15

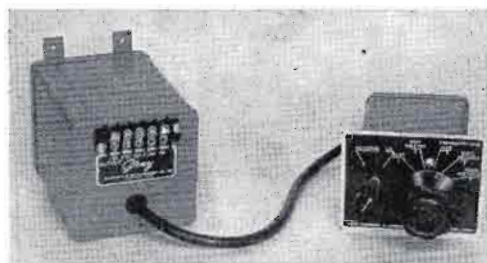
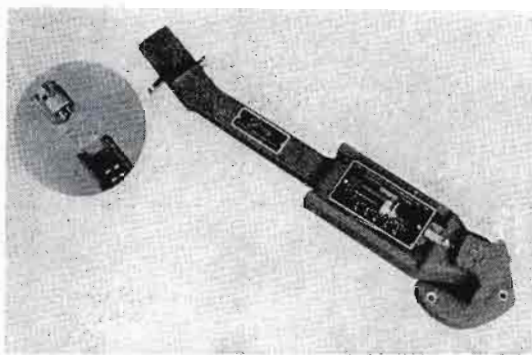

Variable Equalizer 602-C

A precision equalizer engineered to provide highly accurate equalization for latest recording characteristics—for use with GE pickup cartridges. Switch provided for changing from standard to microgroove records. Four equalization curves provided: (1) latest NARTB/AES, (2) intermediate, (3) roll-off, (4) flat. Output: 150 ohms. Output level: -67 VU at 4.7 cm/sec. Made by Gray.

Model 602-C Equalizer \$49.50

Variable Equalizer 603

Similar to 602-C but enlarged upon to have a fifth curve so that either Pickering or GE cartridges may be used. Output: 150/250 ohms. Output level: -50/60 dbm at 7 cm/sec, depending on pickup cartridge selected. Made by Gray.

Model 603 Equalizer \$60.70



GE Baton Tone Arms

Available for both 12" and 16" records. Strong, light weight aluminum with low lateral and vertical inertia. Adjustable cartridge pressure through sliding weight with pressure indicated in grams. Cartridge tilts forward 90° for stylus inspection. Accommodates all GE cartridges. Height adjustable to 2". Size: A1-500 is 10 7/8" long. A1-501 is 14 1/8" long.

Model A1-500 Arm \$31.95
(max. 12" records)

Model A1-501 Arm \$35.50
(max. 16" records)

Stylus Pressure Gauge



Made of plastic. Accurately indicates stylus pressure from 0-30 grams. A necessary instrument where best reproduction and least record wear is a consideration. Made by Livingston.

Model GRL-1 Stylus Pressure Gauge...\$1.89

TONE ARMS, FILTERS, ACCESSORIES

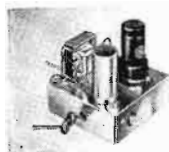

GE UPX-003A Preamplifier

Gain 35 db. High impedance input and output. Operates from 115 volts, 50/60 cycles. Uses 6SC7 tube. Size: $3\frac{3}{8}'' \times 3\frac{5}{8}'' \times 3\frac{3}{4}''$. Where variable equalization desired, it is suggested that the A1-901 record filter, listed below, be used.

Model UPX-003A Preamplifier \$10.77

GE 3-way Record Filter

May be used with or without the cabinet. Approximate size with cabinet: $7\frac{1}{2}'' \times 3\frac{1}{2}'' \times 3\frac{1}{2}''$ high. Provides 4 low frequency adjustments at 0, 40, 60, 80 cycles. Provides 6 compensator adjustments: flat, European 78, London LP, AES, RIAA, Columbia LP. Also has Hi-cutoff control at 3, 5, 9 Kc, and flat. Filter connects between pickup cartridge and preamplifier input, shielded output lead and plug are supplied.

Model A1-901 Record Filter \$19.95



Livingston Universal Arm

Excellent tracking for both 12" and 16" records. Adjustable counter weight. Stylus pressure range 6 to 30 grams. May be used with all GE cartridges including triple play.

Model A-16 Arm \$24.95

Clarkston Arm

Accommodates all records up to 16", both standard and LP. Made of heavy aluminum casting, eliminating audible resonance points. Has adjustable weight on top of arm. Height adjustable. Built with vertical roller bearings and ball thrust bearings, eliminating mechanical bias on turntable. Size: $14\frac{3}{8}''$ long. Finish, gray.

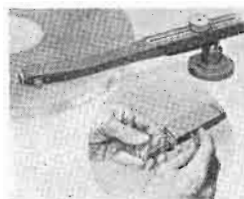

Model 212 Arm only \$22.50

Model 212-G Arm only, slotted for GE RPX-050 cartridge \$22.50

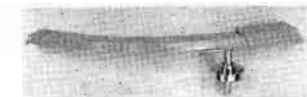

Livingston Special (for GE dual cartridge)

For up to 12" records. Precision weighted to assure correct stylus pressure at 8 grams. Adjustable height. For Hi-Fi or where a reasonably priced, excellent arm is desired that will handle the GE dual cartridge.

Model GR-L-12 Arm \$21.50



Pickering 190-D

Maker states when this arm used with Pickering cartridge, 50% less vertical tracking force is required than with conventional pickups. Offset head reduces tracking errors to less than 5%. Stylus fully protected against contact with anything other than record groove. Overall length $14\frac{1}{4}''$. Adjustable height up to 2". Supplied with magnetic arm rest.

Model 190-D Arm \$31.50

Pickering Preamplifier



Response within 2 db, 40-20,000 cps. Compensates for 6 db per octave loss below 500 cps. Input and output high impedance. Distortion: 0.4% at +10 db. Noise -56 db below maximum signal level. Size: $7\frac{1}{2}'' \times 3\frac{1}{2}'' \times 4\frac{5}{8}''$ high. Tubes: 6C4, 6X4, 6AU6.

Model 230-H Preamplifier \$24.00

Record Compensator

Provides six curves selected from front panel to provide proper response for all records, transcriptions and LP service. Input matches high impedance cartridge such as GE or Pickering. Output 47,000 ohms.



Model 132-E Compensator \$12.00

PICKUP CARTRIDGES — STYLI



A



B



C



D



E

General Electric Reluctance

<u>Part No.</u>	<u>Type</u>	<u>Stylus</u>	<u>Stylus Radius</u>	<u>Fig.</u>	<u>Price</u>
Following with clip-in tip stylus:					
RPX-052A	triple play	diamond and sapphire	.001 diam. .003 saph.	A	\$23.37
RPX-053A	triple play	dual diamond	.001 and .003	A	34.74
RPX-061A	single	diamond	.001 diam.	B	20.37
RPX-063A	single	diamond	.003 diam.	B	20.37
Following with dual stylus:					
RPX-050A	triple play	sapphire	.001 and .003	A	8.37
Following with single stylus:					
RPX-040A	single	sapphire	.003	B	5.97
RPX-041A	single	sapphire	.001	B	5.97
Low impedance cartridges with stylus:					
RPX-145	single	diamond	.001	B	20.37
RPX-146	single	diamond	.0025	B	20.37
RPX-147	dual	diamond	.001 and .0025	A	34.74
RPX-148	single	sapphire	.001	B	5.97
RPX-149	single	sapphire	.0025	B	5.97
RPX-150	dual	sapphire	.001 and .0025	A	8.37
Dual stylus replacement assemblies:					
RPJ-010A	—	sapphire	.001 and .003	—	3.57
RPJ-012A	—	diamond	.001 and .003	—	29.97
RPJ-013A	—	diamond	.001	—	18.60
		sapphire	.003		
RPJ-007A	—	sapphire	.001 and .0025	—	3.57
RPJ-011A	—	diamond	.001 and .0025	—	29.97
Clip-in tip stylus inserts:					
RPJ-01d	—	diamond	.001	—	16.00
RPJ-02d	—	diamond	.0025	—	16.00
RPJ-03d	—	diamond	.003	—	16.00
RPJ-01S	—	sapphire	.001	—	2.00
RPJ-02S	—	sapphire	.0025	—	2.00
RPJ-03S	—	sapphire	.003	—	2.00

PICKUP CARTRIDGES — STYLI

<u>Part No.</u>	<u>Type</u>	<u>Stylus</u>	<u>Stylus Radius</u>	<u>Fig.</u>	<u>Price</u>
Replacement single stylus:					
RPJ-001	—	sapphire	.003	—	2.10
RPJ-003	—	diamond	.003	—	16.50
RPJ-004	—	diamond	.001	—	16.50
RPJ-005	—	sapphire	.001	—	2.10
RPJ-002	—	diamond	.0025	—	16.50
RPJ-006	—	sapphire	.0025	—	2.10

Replacement knob kit for triple play cartridges:

RKP-003	Includes washers, springs, plastic knobs (long and short)				.30
---------	---	--	--	--	-----

Pickering cartridges:

260DD	dual	diamond	.001 and .0027	D	60.00
260DS	dual	diamond	.001	D	48.00
		sapphire	.0027		
D-220	single	diamond	.0027	C	27.60
S-220	single	sapphire	.0027	C	12.60
D-240	single	diamond	.001	C	37.60
350-DD	dual	diamond	.001 and .0027	E	63.00
350-DS	dual	diamond	.001	E	49.50
		sapphire	.0027		

Pickering stylus for 350 Series:

D-3510	—	diamond	.001	—	21.00
D-3527	—	diamond	.0027	—	21.00
S-3527	—	sapphire	.0027	—	7.50

In Ordering Cartridges and Styli

Pickup arms listed on preceding pages in many instances will accommodate either GE or Pickering cartridges. Consult description data for best arm suited to your needs. Broadcasting stations should preferably order diamond stylus as rapid wear of sapphire stylus will require frequent replacement. Where use is less frequent, the sapphire stylus will produce the same quality. All cartridges listed include styli — listing of styli separately is for spare and replacement service. Gates normally carries a large stock at both Quincy and all branches.

DISC CABINETS

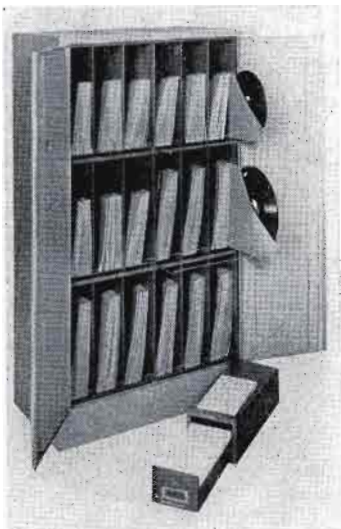

B-540 — C-540 — BC-270

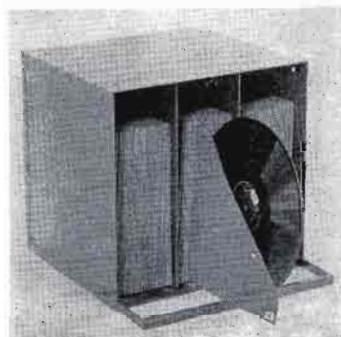

Sectional Discabinet



Pocket

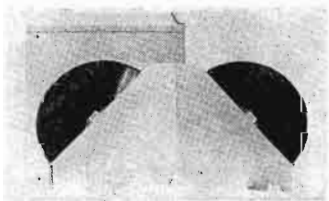

Pocket Swing

Disc Cabinet With Doors

Has double front doors with key lock. 29" wide, 60" high and 14" deep. Baked on gray wrinkle finish. Accommodates any combination of 7-inch, 10-inch or 12-inch records. Comes complete with 540 red wallet record pockets, 2 sets of numbers, 1620 printed catalog cards and steel card file with A-Z index.

Stock No.	Capacity	Price
B-540	540 ten-inch discs	\$201.00
C-540	540 twelve-inch discs	224.00
BC-270	270 ten-inch and 270 twelve-inch discs	211.00

Sectional Discabinets

Comes complete with pockets and cataloging system. Baked on gray wrinkle finish. Includes 2 sets of numbers for disc pockets.

Record Size	Stock No.	Width	Height	Depth	Pocket Capacity	Price
7"	A-7	13 1/8"	9"	9"	90	\$22.50
10"	B-10	13 1/8"	12 3/8"	12"	90	24.75
12"	C-12	13 1/8"	15 5/8"	14"	90	34.65
16"	D-16	13 1/8"	20 5/8"	20"	90	46.75

Cabinets less pockets for albums

7"	AE-7	(same size as A-7)	8.25
10"	BE-10	(same size as B-10)	9.90
12"	CE-12	(same size as C-12)	15.40

Assembled Sectional Discabinets

Right illustration shows how sectional discabinets, listed above, may be stacked both vertically and laterally, giving the appearance of a single unit. This illustrated unit is comprised of three D-16 at base, three C-12 and nine B-10 units. Capacity 1350 discs taking floor space of 39 1/2". Note top section is for albums.

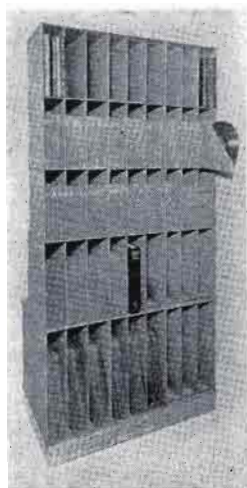

At left is illustrated the discabinet pocket made of strong 11-point red wallet to stand a 140 lb. bursting test. Each pocket has metal eyelet in corner for swing.

The pocket swing is well illustrated at the bottom left. At the right position the pocket is extended — at left position pocket rests in cabinet.

TAPE CABINETS

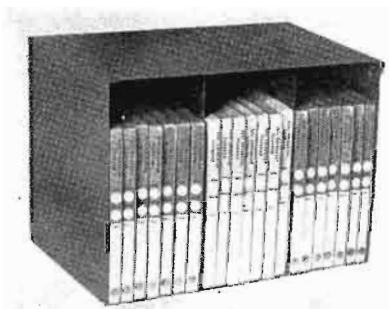

TR-1021

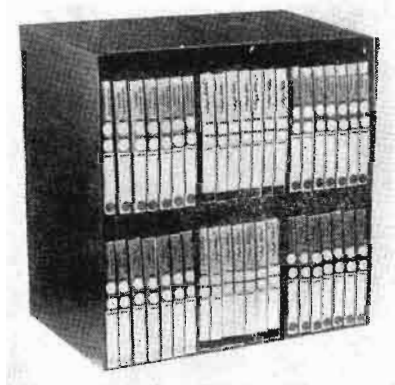

TR-542 — TR-742

These sectional tape cabinets may be bolted together either vertically or horizontally, quite similar to the disc cabinets on the opposite page. May also be attached as portion of discabinet. Made of steel and finished in gray ripple enamel.

Model TR-542:	For 5-inch reels, accommodates 42 reels in 6 compartments. Size: 13 1/8" wide, 12 5/8" high, 8 5/8" deep.	\$11.50
Model TR-742:	Same as TR-542 only accommodates 7-inch reels. Capacity 42 reels. Size: 13 1/8" wide, 16 1/2" high, 8 5/8" deep.	13.50
Model TR-1021:	For 10 1/2" reels. Accommodates 21 reels in 3 compartments. Size: 13 1/8" high, 12 5/8" wide, 12" deep.	9.90

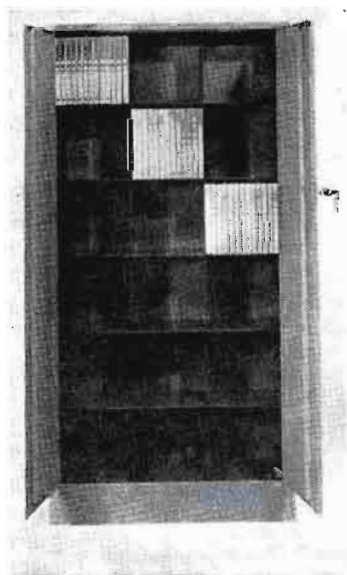

ALL STEEL TAPE CABINET (with locking doors)

A rugged cabinet with double front doors that may be locked. Available for all reel sizes as listed below. Made of stretcher level steel, resistance welded and finished in durable gray ripple enamel. All styles are 29" wide, 60" high and 10" deep. Shipping wt. 160 lbs.

Model 5384:	For 5-inch reels. Capacity 384 reels in 24 compartments.	\$114.00
Model TR-7288:	For 7-inch reels. Capacity 288 reels in 18 compartments.	108.00
Model TR-192:	For 10 1/2-inch reels. Capacity 192 reels in 12 compartments.	110.00

SAVE TIME when ordering by making sure type number, full description and prices are shown for all items.

AMPEX TAPE RECORDERS



350C



352C



9093



475

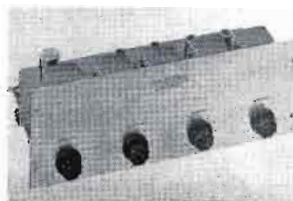

3761

The Ampex 350 series is one of the finest tape recorders made today. Available in console (as illustrated), rack and portable models.

Data Model 350: For 7½" and 15" sec. or 3¾" and 7½" sec. Response: at 15" sec., 30-15,000 cps; at 7½" sec., 40-10,000 cps; at 3¾" sec., 50-7500 cycles. Accommodates 2400' reels to allow 2 hours at 3¾" sec., one hour at 7½" sec., and 32 min. at 15" sec. Meets all NARTB standards. Includes all power supplies, record and playback amplifiers, erase, record and playback heads, cables and connectors. Input impedance: Bridging 600 ohms. Output: 600 ohms at +4 VU.

Model 350C:	Console type as illustrated	\$1315.00
Model 350P:	Two case portable	1293.00
Model 350R:	Rack type, less rack	1205.00

NOTE: Above for 7½"/15" sec. For 3¾"/7½" add \$65.00.

Model 352C:	Playback only, illustrated above, for 7½"/15" sec. Output: 600 ohms at +4 VU	935.00
Model 9093:	Reel hold down knobs for rack recorders	7.40
Model 475:	Replacement head assembly including erase, record, playback and cables	193.00
Model 3761:	Four-channel mixer, includes individual preamplifiers. Input: 150/250/600 ohms. Output: 50/150/250/600 ohms	275.00

WHEN ORDERING, specify whether for full or half-track. 60 cycle models will be supplied unless 50 cycles stipulated.

NOTE: Ampex tape recorders are shipped freight allowed.

AMPEX TAPE RECORDERS



300 Heavy Duty Series

In radio network broadcasting, pre-disc recording and master tape recording of many types, the Ampex 300 Series dominates the heavy duty recording field. Manufacturer claims superb mechanical stability with complete absence of flutter, split-second timing and the widest of frequency response. — Easy editing, solenoid push-button operation, fast start, long-life magnetic heads and quick acting mechanical brakes are only a few of the many outstanding Ampex 300 features.

SPECIFICATIONS

TAPE SPEED: 7½" and 15", single control speed change.

FREQUENCY RESPONSE: 15", ±2 db, 30-15,000 cps.
7½", ±4 db, 40-15,000 cps.

NOISE: Over 70 db unweighted (noise to recording level).
Over 60 db as defined by NARTB standards.

TIMING: Start: in 1/10 sec. Stop: at 15" sec. in 2" tape. Playback: 0.2%. Playing Time: 66 min. at 7½" sec. or 33 min. at 7½" sec. Rewind: 1 min. for 2400'.

CONTROLS: Start, stop, record pushbutton/relay operated and may be remote controlled. Normal play, fast forward and rewind on selector switch.

MONITORING: Tape may be monitored while recording.

AMPLIFIERS: Record amp: 10,000 ohms bridging input at +4 VU.
Playback amplifier: adjusted for +4 VU at either 600 or 150 ohms.

ORDERING DATA

NOTE: Ampex tape recorders are shipped freight allowed.

Model 300C: Console type as illustrated \$2046.00

Model 300R: Rack mount type 1951.00

Meter Panel: if not desired, deduct \$138.00

IMPORTANT: When ordering, state whether full track or half track desired.
Recorders will be supplied for 60 cycles unless 50 cycles stipulated on order.

AMPEX TAPE RECORDERS



Model 600 Recorder

One of the finest, modestly priced tape recorders ever manufactured. For broadcasting and recording. Available for either 7½" or 3¾" sec. Includes tape transport mechanism, two record amplifiers (one for mic and one for line), playback amplifier, separate erase, record and playback heads, VU meter and all accessories. Supplied in portable case as shown to left or unmounted for attachment to No. 9684 rack adaptor listed below.

Model 600 portable recorder

7½" sec. \$545.00

Model 600 unmounted recorder

7½" sec. 498.00

NOTE: Add \$30.95 if 3¾" sec. desired.

Model 620 Amplifier—Speaker

A fine companion for reproducing the wide capabilities of the 600 recorder. Included in matching portable case is a ten watt, 1% distortion, 20-20,000 cps amplifier feeding a broad range speaker into an acoustically correct baffle. External speaker jack bypasses internal speaker so amplifier may be used for PA. Comes complete with cables and includes reciprocal network, level control and equalization control. Here is an item you must hear to appreciate.

Model 620 portable amplifier-speaker \$149.50



Rack Mount Adapter

For 19" rack mounting of 600 recorder. Consumes 17½" of rack panel space. Made of steel and finished to match 600 recorder.

Model 9684 rack adapter....\$12.50



Low Impedance Microphone Input Kit

Includes transformer, adaptor fittings and instructions for mounting in 600 recorder where microphone is low impedance. Will match 50/150/250/600 ohms input.

Model 9359 transformer kit \$16.50



612F

Tape Playback Units

These Ampex units are for professional reproduction of either stereophonic or single track but not intended for recording purposes. Beautifully styled in blonde or mahogany. For stereophonic, two 620F speaker units required while for straight tape playback, one 620F required. Plays at 7½" sec. with 40-15,000 cps response. Size: 612F playback 9"x15"x17½"; 620F speaker 9½"x11"x21".

Model 612F stereophonic unit \$395.00

Model 620F speaker unit 169.50

NOTE: Priced in mahogany. Add \$10.00 per unit in blonde.

These units shipped freight allowed in the U. S. When ordering, state whether half or full-track. Will be supplied for 60 cycles unless 50 cycles stipulated on order.



620F

AMPEX TAPE EQUIPMENT

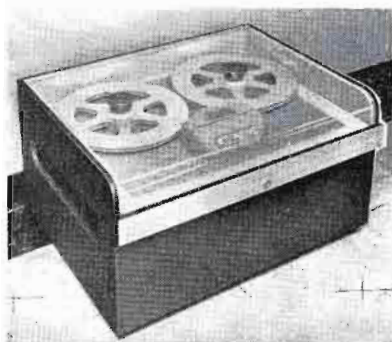

NOTE: Models listed right include automatic reversal. If manual reversal desired, deduct \$100.00 from any model. If 7½" sec. desired, add \$30.00.

450 SERIES REPRODUCER

A professional type tape reproducer only that plays in both forward and reverse, offering a total of 8 hours continuous with 14" reel at 3¾"/sec. Includes power supply, playback preamplifier, half-track playback heads, tape transport, cables, connector and one 14" reel. Will also accommodate 8" and 10½" reels. Price includes freight allowed in U. S. 60 cycle type will be supplied unless 50 cycles stipulated. Table-top console model illustrated to left.

- | | |
|---|-----------------|
| Model 450T Table-top console
3¾" sec. | \$875.00 |
| Model 450C Floor type console
3¾" sec. | 979.00 |
| Model 450R Rack type reproducer
3¾" sec. | 743.00 |

INDUSTRIAL TAPE SOUND SYSTEM

For restaurants, department stores, shopping centers, railway stations or wherever fine continuous music is desired. Designed for dual purpose of background music and PA. Consists of a continuous tape recorder and choice of 30 or 120 watt audio system.

All components are housed in a totally enclosed rack with side opening doors. Includes cables, paging microphone and all accessories. Size: 76" high, 26" wide, 20" deep.

Price includes timing panel, sensing panel, paging panel and ready to install. Loudspeakers are listed in this catalog (loudspeaker section — see index). Gates field sales engineers will gladly assist interested parties in working out exact equipment requirements. Additional detail available on written request.

- | | |
|---|------------------|
| Model S3371 complete system (30 watts) .. | \$1680.00 |
| Model S3370 complete system (120 watts) .. | 1930.00 |

USE THESE GATES PHONE NUMBERS

Quincy, Ill. (Factory)	Baldwin 2-8202
New York City	Murray Hill 7-7971
Washington, D. C.	Metropolitan 8-0522
Atlanta, Georgia	Elgin 0369
Houston, Texas	Capitol 8-8536
Los Angeles, Calif.	Hollywood 2-6351



Model 3370

AMPEX TAPE RECORDERS

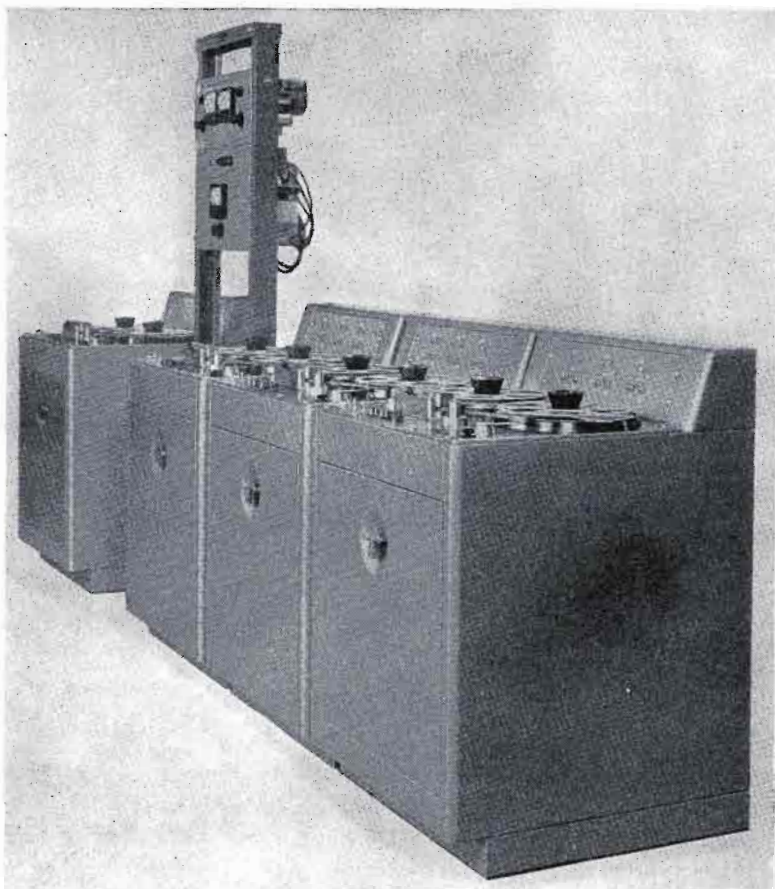

Tape Duplicators

Consists of master playback machine, master control panel and from one to ten slave recorders. Capable of duplicating single or double track or 2-channel stereophonics. Handles $3\frac{3}{4}$ "", $7\frac{1}{2}$ " and 15" sec. Basic system includes: (1) complete playback machine with amplifiers, two half-track heads and controls, (2) master control panel with dual record amplifiers, power supply, dual level meters, bias oscillator, bias level meter, equalizer and master controls, and (3) one slave recorder with one full and two half-track heads. Additional detail gladly supplied on request.

Model S-3201C basic system, consoles for $10\frac{1}{2}$ " reels\$6325.00

Model S-3201R basic system, rack type for $10\frac{1}{2}$ " reels 6138.00

NOTE: If 14" reels desired, add \$847.00 to either model above.

Model S-3201S-GR additional slave recorder, console $10\frac{1}{2}$ " reels.... 1683.00

Model S-3201SR-GR additional slave recorder, rack $10\frac{1}{2}$ " reels..... 1595.00

NOTE: If 14" reels desired, add \$396.00 to either model above.

Freight allowed in the United States.

60 cycle model supplied unless 50 cycles stipulated when ordering.

GATES

AMPEX TAPE RECORDERS



Automatic Programming System S-3380

This system provides (1) 12 full hours of program material at $3\frac{3}{4}$ " /sec. and as much as 3 hours of local announcements at $7\frac{1}{2}$ " /sec., (2) automatically corrects itself to station clock each half hour, (3) automatically inserts station breaks, (4) provides facilities for recording while broadcasting, and (5) may also be used to control automatic record changer.

System S-3380 includes:

- 2 type 450B playback units.
- 1 type 350C recorder-playback.
- 1 record console.
- 1 program control unit.
- 1 relay rack cabinet.
- 1 remote start control.

Basic operation is in no way complicated and Gates sales engineers will gladly outline full details by personal visitation or additional data available in brochure form.

Model S-3380 automatic program system\$4950.00

AMPEX REPLACEMENT PARTS

The following list of spare and replacement parts are for current and earlier models of Ampex equipment. Part numbers shown correspond to those in Ampex instruction book.

Part No.	Description	Price	Part No.	Description	Price
328	Brake Band	\$ 3.50	6218	Spring	\$.10
337	Solenoid	6.55	6219	Dust Seal (Capstan-Felt)	.05
342	Reel Guard	4.00	6239	Drive Motor	35.70
361	Play Push-button Guard	.40	6244	Hub (with shaft)	2.20
438	Gate Spring	.20	6246	Spring	.30
457	Glass Tape Guide (Gate)	.20	6248	Disc Assembly	2.70
463	Record Push-button Guard	.45	6251	Clutch Assembly	4.60
475-1	Head Assembly, Full-Track	193.00	6262	Felt Washer, Capstan	.10
475-2	Head Assembly, Full-Track	193.00	6263	Belt Idler	6.40
475-6	Head Assembly, Half-Track	193.00	6284	Rewind Idler Assembly	10.00
475-7	Head Assembly FT Rec 1/2 T PB	193.00	6293	Collar (Drum)	.75
475-11	Head Assembly, Half-Track	193.00	6319	Hold-down Knob	.50
475-14	Head Assembly, Half-Track	193.00	6320	Hold-back Brake Assembly	1.60
475-15	Head Assembly, Full-Track	193.00	6351	"VU" Meter	25.65
475-16	Head Assembly, Full-Track	193.00	6392	Maintenance Kit	5.00
475-17	Head Assembly, Half-Track	193.00	6757	25 Cycle Reversing Tape, 3 3/4 ips	2.50
475-18	Head Assembly, Full-Track	193.00	6757-1	25 Cycle Reversing Tape, 7 1/2 ips	2.50
475-22	Head Assembly, Half-Track	137.50	6792	Speed Conversion Kit to 3 3/4 ips	18.90
500	Capstan Idler, 7 1/2 & 15 ips	27.15	6792-2	Speed Conversion Kit to 7 1/2 ips	9.60
670	Solenoid	8.70	6792-4	Speed Conversion Kit to 7 1/2 ips (RI)	11.60
673-1	Speed Change Switch	2.40	6924	Brake Lining (Cork)	.35
673-2	Equal Change Switch	2.40	6938	Brake Modification Kit	1.15
704	Head Demagnetizer	8.25	7556	Speed Conversion Kit to 3 3/4 ips	18.95
720-1	Brake Band Leaf	.10	7666	Mounting Foot	.05
720-2	Brake Band Leaf	.10	7772-2	3 3/4 ips Motor Replacement Kit	5.00
853	Torque Motor	47.75	7773-3	7 1/2 ips Motor Replacement Kit	14.10
962	Brake Lining (Felt)	.40	7801	Idler and Bearing Kit	8.00
976	Reel Centering Adapter	.55	7802	Minor Hardware Kit	5.00
995	Capstan Idler	20.45	9064	Switch Deck	.55
1030	Drive Motor, 7 1/2-15 ips	102.70	9093	Hold-down Knobs	7.40
1089	Drive Motor	114.55	9359	Microphone Input Transformer Kit	16.50
1372	Glass Tape Guide (Head)	.20	BC-8	Ball-Bearing (Tape Guide)	1.35
1917	Editing Knob	3.85	CH-8	20 Mh Choke (Miller No. 691)	1.10
2102	Torque Motor	82.50	CH-62	5.5 Mh Choke (Merit No. C-2975)	1.45
2216	Drive Motor	117.30	CS-5	Power Cord	1.30
245B	Torque Motor	72.75	DL-4	Post Light, 1/4 W Neon	.95
2871-1	Drive Belt, 3 3/4"	2.50	KN-7	Bar Knob	.15
2872-2	Drive Belt, 7 1/2"	2.50	KN-14	Knob (Skirt)	1.05
2873-3	Drive Belt, 7 1/2"	2.50	MO-13-1	Drive Motor	43.80
3853	Brake Lining	.50	OR-10	Takeup Belt	.20
3953	Power Transformer	11.15	PL1-5	Output Plug	1.70
3965	Brake Modernization Kit	10.95	PL33P	Input Plug	1.65
4192	Capstan Idler	2.40	RE-584	Potentiometer, 100K ohm	1.65
4217	Brake Kit	10.80	RE-585	Potentiometer, 1 megohm	2.05
4314	Capstan and Head Assembly	176.00	RL-2	Speed Change Relay	8.95
4494	Alignment Tape, 15"	12.00	RL-8	Record Relay	9.65
4299	Turntable Belt	2.30	RL-21	Fast-forward-Rewind Relay	8.45
5563	Alignment Tape, 7 1/2"	12.00	RL-26	Fast-forward-Rewind Start Relay	9.70
6000	Alignment Tape, 3 3/4" and 7 1/2"	12.00	SR-4	Selenium Rectifier	13.10
6092	Capstan Idler, 3 3/4" and 7 1/2"	18.65	SW-12	Start Switch	2.10
6150	Drive Motor, 7 1/2-15 ips	117.30	SW-34	Push-button Switch, N. O.	.75
6206-10	Head Assembly, Full-Track	95.00	SW-35	Push-button Switch, N. C.	.85
6206-20	Head Assembly, Half-Track	95.00	TU-12	125J7 Tube (Selected)	3.30
6211	Capstan Idler	6.90	TU-58	5663 Thyatron	2.10

MAGNECORD TAPE RECORDERS

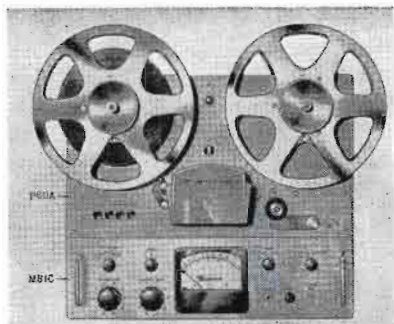

M81C Amplifier

Includes 4" VU meter reading bias, record and playback level. Consists of two amplifiers for record and playback. Operates direct from high impedance input for bridging or low level microphone (plug-in transformer available for low impedance microphone). Output 20,000 ohms bridging output level +6 dbm. Distortion 0.6% at 400 cycles. Noise: 66 db. below 1000 cycle normal level tape signal. Meets all NARTB standards. Tubes: two each 6XK7, 12AU7; one each 5Y3GT, 12AX7, 12B17. Plug-in input and output transformers priced to right.

P60 Recorder—M81C Amplifier

This combination upholds the Magnecord fine reputation for excellent tape recording and reproduction for radio and TV broadcasting—and at a very modest price. Tape speed 7½" and 15". Direct motor capstan drive. Accommodates up to 10½" reels (2400 feet). Deep slot loading. Three heads—erase, record, playback allow simultaneous playback. Starting and stopping time (to normal forward) instantaneous. Response: 40-15,000 cps at 15" or 40-10,000 cps at 7½". Timing accuracy ±3 sec. for 30 min.

Model P60-AX Recorder, less case	\$390.00
Model P60-B81 complete recorder amplifier in carrying case	625.00
Model 32X33 plug-in input transformer for 50/200 ohm mic	25.00
Model 32X34 plug-in output transformer for 600 ohms balanced	25.00
M81C Amplifier only (rack mount)	245.00

Citation Model F35-B

A complete tape recorder with 8-watt playback amplifier for schools, universities, business and industrial applications. Includes loudspeaker. Total weight 40 lbs. Tape speed 3¾" or 7½". Response excellent up to 10,000 cycles. Plays two hours half-track at 3¾" sec. or one hour half-track at 7½" sec. Has self-contained illuminated VU meter.

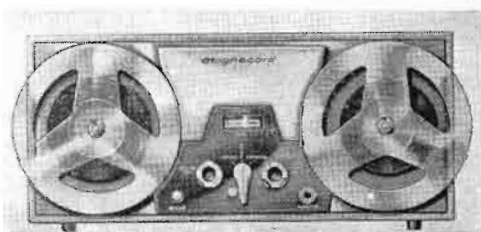

Model F35-B complete recorder in portable case supplied with shaded pole motor.....	\$349.00
Model S35-B, same as above but synchronous motor	399.00

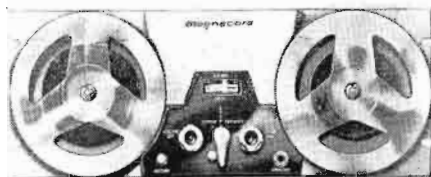

Magnecord S36-B

A modest priced professional performer for rack or portable use. Tape speed 7½" or 15" with hysteresis synchronous motor. Panel size: 19"x7". Has illuminated VU meter, input for Hi-Z mic or bridging (input transformer for Lo-Z available). Playback amplifier output 600 ohms at +9 dbm. Response: 50-12,000 cps at 7½" sec.

Model S36-BX rack mount	\$370.00
Model S36-B in portable case	395.00
Model 91X1745 plug-in input transformer for Lo-Z mic	25.00



TEST TAPE

Tests recorded on life-time tape for: wow and flutter; head azimuth alignment; frequency response; signal to noise ratio; maximum signal level and tape speed.

D-110 for 7½" sec.	
D-111 for 15" sec.	
D-110 Test Tape	\$12.50
D-111 Test Tape	17.50

Important In Ordering Tape Recorders

Most tape recorders are available in either half-track or full-track models. Half-track is where half the tape is used in recording in one direction and half in the other. Full-track uses the entire tape in one direction. The latter is standard for most broadcasting operations. Be sure and state your desires when ordering. — Tape recorders are usually supplied for 60 cycle operation. In some parts of the world, 50 cycles prevails. It is important to state your line frequency when ordering. Most of the U. S. is 60 cycles. Freight allowed in United States on Magnecord recorders.

MAGNECORD TAPE RECORDERS

M81 Console Recorder

Here is a fine, professional recorder to replace existing recorders of older vintage or for the finest new installations. Meets all NARTB standards. Split-second timing, slot loading, high speed cueing, 4" VU meter, pushbutton control, front panel speed change and equalization, choice of microphone input and output impedances with plug-in transformers. Full specifications at bottom of page. Handles up to 10½" reels (2400 feet). Standard model for 7½"/15" sec. but 3¾"/7½" sec. available at slight extra cost. Size: 28" wide, 28" deep, 41" high.

Model M81-ACC Console Recorder...\$975.00



M81 Portable Recorder

Same unit as listed above only in attractive leatherette covered carrying cases with total weight, both cases, 88 lbs. Front covers supplied but removed for illustration. These recorders feature fail safe operation even in high speed forward or reverse.

Model M81-AC Portable Recorder...\$870.00



M81 Rack Recorder

Includes complete equipment for rack mounting, consuming 19"x17½" rack space. Full specifications listed below.

Model M81-ACX Rack Recorder...\$790.00

Specifications M81-ACC, M81-AC, M81-ACX

TAPE SPEED: 7½ and 15 ips (3¾ and 7½ ips available on special order).

STARTING TIME: Less than 0.1 sec.

STOPPING TIME: Less than 2" of tape at 15 ips.

TIMING ACCURACY: ±3 sec. in 30 min.

FLUTTER AND WOW: Less than .15% RMS max.

at 15 ips; less than .2% RMS max. at 7½ ips; less than .3% RMS max. at 3¾ ips.

REWIND AND HIGH FORWARD: 10"—2400 ft. reel less than 55 sec.

SIGNAL-TO-NOISE: 55 db at 7½ and 15 ips.

FREQUENCY RESPONSE: 40-15,000 ±2 db 15 ips; 40-10,000 ±2 db 7½ ips; 50-7500 ±2 db 3¾ ips.

MONITORING: Phone jack on panel for monitoring.

PANEL: Standard 19-inch rack.

SIZE AMPLIFIER: 19"x5¼".

TRANSPORT SIZE: 19"x12¼".

POWER SUPPLY SIZE: Integral with amplifier panel.

POWER CONSUMPTION: 290 watts.

WHEN ORDERING: Freight allowed in the United States on Magnecord recorders. Unless otherwise stated, 115 volt 60 cycle models will be supplied.

GATES

MAGNECORD TAPE RECORDERS



M90 Console Recorder

In advanced tape recorders, this professional model offers a host of features plus extended frequency response over earlier Magnecord models. Slot loading, interlocking pushbutton control, two-speed direct tape drive, high-speed forward and rewind cueing, separate record and playback amplifiers, 4" VU meter and front panel speed and equalization control. Conforms fully to NARTB standards. See specifications at bottom of page. Size: 28" wide, 28" deep, 41" high. Standard speed 7½"/15" sec. Also available for 3¾"/7½" sec. at slightly higher cost.

Model M90-ACC Console Recorder...\$1450.00

M90 Portable Recorder

Same identical electrical design as console model above, only two-case portable model, weighing total of 92 lbs. The use of direct coupled cascade amplifier greatly reduces maximum signal to noise ratio. Handles all reels up to and including 10½" (2400' capacity). Finish in black leatherette and covers, removed for illustration, are standard equipment.

Model M90-AC Portable Recorder...\$1365.00

M90 Rack Recorder

Same as above, specifications below, but for rack mounting. Rack space 19"x17½".

Model M90-ACX Rack Recorder...\$1285.00



Specifications M90-ACC, M90-AC, M90-ACX

TAPE SPEED: 7½ and 15 ips. (3¾ and 7½ ips available on special order).

STARTING TIME: Less than 0.1 sec.

STOPPING TIME: Less than 2" of tape at 15 ips.

TIMING ACCURACY: ±3 sec. in 30 min.

FLUTTER AND WOW: Less than 0.1% max. at 15 ips; Less than 0.15% max. at 7½ ips; Less than .3% max. at 3¾ ips.

REWIND AND HIGH FORWARD: 10"—2400 ft. reel less than 55 sec.

FREQUENCY RESPONSE: 30 to 15,000 ±2 db 15 ips; 40 to 12,000 ±2 db 7½ ips; 30

to 15,000 ±4 db 7½ ips; 50 to 7500, 3¾ ips.

SIGNAL-TO-NOISE: 58 db at 7½ and 15 ips.

MONITORING: Phone jack on panel for monitoring.

PANEL: Standard 19" rack.

SIZE AMPLIFIER: 19"x5¼".

TRANSPORT SIZE: 19"x12¼".

POWER SUPPLY SIZE: Integral with amplifier panel.

POWER CONSUMPTION: 290 watts.

WHEN ORDERING: Magnecord recorders are freight allowed in the United States whether full or half-track desired. Unless otherwise stated, 115 volt, 60 cycle model will be supplied.

MAGNECORD REPLACEMENT PARTS

The following spare or replacement parts are for current and earlier popular model Magnecord recorders.
Part numbers are standard Magnecord catalog numbers.

For PT6-AH and PT6-AHX; PT63-AH and PT63-AHX

Part No.	Description	Price	Part No.	Description	Price
Parts on Front Panel					
91A17	Head, 0.270 Track Erase Complete for PT6-AH Type Unit	\$ 22.50	91A86	Drive Puck (2½" wheel) assembly	1.75
91A17R	**Reconditioning Service for above	15.10	91A130	Take-up Puck Wheel (2" wheel)	1.50
91A57	Head, Full Track Record/Reproduce Complete for PT6-AH Type Unit	42.00	78A12	Fast Forward Linkage (Long)	.35
91A57R	**Reconditioning Service for above	12.25	72A13	Fast Forward Linkage (Short)	.30
91A167	Head, Half-Track Erase Complete for PT6-AH Type Unit Inner Track	22.50	67A12	Hair Pin Retainers (Drive Pucks) doz.	.40
91A121	Three Head Assembly Complete for PT63 Mech	91.85	77A4	16 oz. Puck Spring doz.	2.00
91A121R	Head Reconditioning Service	24.50	77A6	32 oz. Pressure Arm Spring	.25
**Note: Estimates only. Additional charges will be based on other replacement parts used to bring the unit up to specifications.					
614K5	Knurled Retainer Screw for Pressure Rollers	.35	Interconnecting Cables		
614K6	Knurled Retainer Screw for Capstans	.35	91X103	Cable, Interconnecting, Power Control (PT6-AH to PT6-P, PT6-J) (Cannon Plugs)	10.00
6125K8	Knurled Mounting Screw	.25	91X104	Cable, Interconnecting, Audio (for all PT6-AH and PT63 Equipment) (Cannon Plugs)	6.75
63A9	Friction Felts	.10	Parts for Amplifiers		
63A11	Rubber Pressure Disc	.20	14A9	Gain Control for PT6-J, PT63-J	.75
74A21	Bearing for Capstan Shaft—Back or Front	.40	42X2	Rectifier, Copper Oxide	3.30
75A15	Capstan, 60 cycle, 15" per/second	8.70	43X2	Switch, 3 Position Selector, not wired	8.50
75A16	Capstan, 60 cycle, 7½" per/second	7.45	43X20	Switch—VU meter	1.50
75A21	Capstan, 50 cycle, 15" per/second	17.60	46B8	Meter, Illuminated, 3½" VU Scale A	24.00
75A96	Safety Shaft Knob	.65	87X5	Knob, Pointer Type	.85
77A2	Rewind Pawl Spring	.45	Condensers for Amplifiers		
77A25	1 dz. Head Adjusting Springs	.25	23X8	1000 MFD 15 Volt Filter	2.00
87A8	High Speed Forward Knob	.75	Special Blank Panels		
87A15	Knob, Control—Pointer Type	.75	Finished Magnecord Gray		
91A5	Reel Retainer, Knob and Spring for serial 7200 and above	.90	71B139	Rack Adaptor Plates	3.00
91A6	Take-Up Shaft Assembly, complete	25.00	71C237	Rack Adaptor Plates, PT6-G	3.00
91A8	Rewind Motor Assembly, complete	42.25	Parts for 93X4, Adapter Arms		
91A9	Tape Guide Roller Assembly—flanged type, complete	4.00	86X39	Belts	1.00
91A30	Switch Arm and Pin Assembly	1.65	91X559	Adaptor Knob Assembly	3.75
91A54	Tape Guide Roller Assembly—flat type, complete	4.50	M30/33 Heads		
91A11	Pressure Arm Assembly—less Pressure Roller	8.75	91X1369	M30 full-track record/playback head assembly	42.00
91A14	Pressure Roller, 60 cycle, 7½" per/second	2.75	91X1369R	Reconditioning charges	12.25
91A15	Pressure Roller, 60 cycle, 15" per/second	2.75	91X1368	M30 erase head assembly, full-track	22.50
91A19	Pressure Roller, 50 cycle, 7½" per/second	3.60	91X1368R	Reconditioning charges	15.10
91A20	Pressure Roller, 50 cycle, 15" per/second	3.60	91X1237	M30 half-track record/playback head inner track	42.00
91A31	Safety Shaft Assembly	1.40	91X1237R	Reconditioning charges	12.25
91A70	Lock Nut Assembly	1.75	91X1242	M30 half-track erase head assembly inner track	22.50
91A84	Rewind Motor, less flange	37.50	91X1242R	Reconditioning charges	15.10
93X6	Springs, Complete set for PT6-AH or AHX	2.75	M-81 Heads		
6112F12	Head Adjusting Screw doz.	.50	91X1598	M81 head assembly, full-track	175.00
Parts on Back Panel					
22A8	Condenser for Two Speed Main Drive Motor (6.0 MFD-220 V. EAD)	5.00	91X1598R	Reconditioning charges	45.00
22A12	Condenser for Single Speed Main Drive Motor (4 MFD-220 V. EAD)	5.00	91X1599	M81 head assembly, half-track	175.00
31A1	Solenoid (for take-up puck operation) less plunger	5.25	91X1599R	Reconditioning charges	45.00
31S6	Oscillator Coil	2.50	M-90 Heads		
35C2	Two Speed Main Drive Motor (900-1800 rpm)	56.00	91X860	M90 head assembly, full-track	255.00
35C5	Single Speed Main Drive Motor (1800 rpm only)	49.00	91X860R	Reconditioning charges	125.00
42X1	Rectifier, Selenium for Solenoid (FTR No. 404D2795)	3.00	91X967	M90 head assembly, half-track	255.00
43X14	Motor Control Switch only, notched handle-toggle	1.75	91X967R	Reconditioning charges	125.00
91A26	Drive Puck Assembly (2½" wheel)	4.50			
91A27	Take-up Puck Assembly (2" wheel)	5.00			
91A29	Motor Control Switches and Bracket Assembly Complete	5.25			

BERLANT TAPE RECORDERS



BRX-1 with BRPAC case/amplifier

Here is an advanced recorder the maker claims has fine exclusive features: (1) A-B test fader allows monitoring between incoming signal and playback from tape without transients. Separate controls for record and playback permit sufficient level to compare incoming and recorded signal on tape... (2) Provision for 5 heads, often eliminates second recorder. An extra playback head and amplifier permit transmitting a delayed broadcast while recording and monitoring another program when using half-track heads.

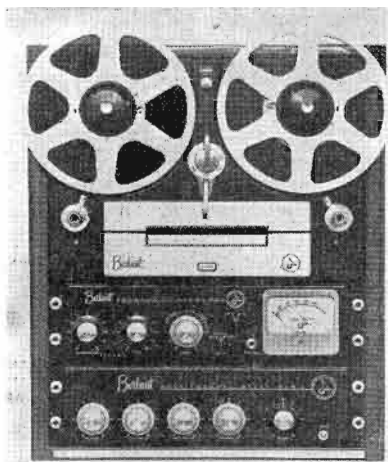

BRX-1 with MCM2 mixer

Specifications

MOTOR: Hysteresis synchronous.

MIXER: Two Hi-Z channels (plug-in transformers for Lo-Z available).

CONNECTORS: Cannon XL standard.

CUEING-EDITING: Cue lever releases brake for rotating reels by hand. When exact cue position reached, cover opens for free tape access.

TAPE SPEEDS: Models BRX-1 and BRX-2 — $7\frac{1}{2}''/15''$ sec.
BRX-3S, BRX-3D — $7\frac{1}{2}''/3\frac{3}{4}''$ sec.

RESPONSE: ± 2 db 40-15,000 cps at $15''$.
 ± 4 db 40-15,000 cps at $7\frac{1}{2}''$.
 ± 2 db 50-5000 cps at $3\frac{3}{4}''$.

IMPEDANCE: Hi-Z or Lo-Z (with T3344 trans.) at 1 MV mic input.

Output: cathode follower or 600 ohms balanced with T2560 trans. out 0 VU.

SIZE: Mechanism $19''$ wide, $14''$ high. Amplifier $19''$ wide, $5\frac{1}{4}''$ high.

MCM2 MIXER (optional), 4 channels each with preamplifier, input Hi-Z or Lo-Z (with T3344 plug-in trans.), output cathode follower or 600 ohms balanced with T2560 plug-in transformer. Size: $5\frac{1}{4}''$ high, $19''$ wide.



BRX-1 recorder

Cat. No.	Description	Price
BRX-1	$7\frac{1}{2}''/15''$ sec. single track erase and record heads, dual track playback to play both single and dual track (rack mount) ...	\$595.00
BRX-2	Same as BRX-1 but with 3 dual track heads	595.00
BRX-3S	Same as BRX-1 but for $3\frac{3}{4}''/7\frac{1}{2}''$ sec.	620.00
BRX-3D	Same as BRX-2 but for $3\frac{3}{4}''/7\frac{1}{2}''$ sec.	620.00
MCM-2	Mixer with Cannon connectors (rack mount)	145.00
T3344	Plug-in input trans. Pri. 50/250 ohms	18.00
T2560	Plug-in output trans. Sec. 600 ohms bal.	25.00
BRPAC	Case for BRX-1 amplifier plus loudspeaker and power amplifier	102.50
CC-1	Case for BRX-1 amplifier only	24.50
BRDC	Case for BRX-1 mechanism	47.50
BRAC	Case for BRX-1 amplifier and MCM2 mixer	47.50
BRDA	Case for BRX-1 mechanism and amplifier	67.50

NOTE: All units for 115 volts, 60 cycles unless otherwise stated. Freight allowed in U. S. on Berlant recorders.

TAPE RECORDING EQUIPMENT



Berlant Automatic Recorder

Same electrical characteristics as BRX-1 on preceding page but automatic (solenoid) operated. Has single track erase and record heads, dual track playback. A single automatic control lever operates stop, start, fast forward and reverse. Dual brakes provide electronic dynamic braking in all normal operations plus "fail safe" reserve mechanical brakes. May be remote controlled with RCU remote unit. Colored lights inform operator of all remote sequences.

Model BAX-1 Automatic recorder (rack mount)\$745.00
 Model RCU Remote control unit 47.50
 Model BAX-2 Same as BAX-1 but 3 dual
 track heads 745.00

NOTE: May be had with portable case or with MCM-2 mixer. See preceding page for prices.

Spring-Wound Tape Recorder

Where power line is unavailable, the Tapak recorder offers professional quality with a spring-wound power unit and battery operated amplifier. Cranking interval 12 min. at $3\frac{3}{4}$ " or 8 min. at $7\frac{1}{2}$ ". All models include: volume indicator, crystal mic., headphone, carrying strap, batteries, reel of tape, built-in flashlight, stroboscope, external start-stop control and portable case. Standard models $7\frac{1}{2}$ " sec. $3\frac{3}{4}$ " optional.

Simplex Newscaster: Records, erases, monitors, plays back and rewinds. Response 100-6000 cps at $7\frac{1}{2}$ "\$289.50

Duplex Newscaster: Same as above, but extended response to 100-9000 cps at $7\frac{1}{2}$ " 349.50

NOTE: For operation on both $7\frac{1}{2}$ " and $3\frac{3}{4}$ " sec, add \$9.50.

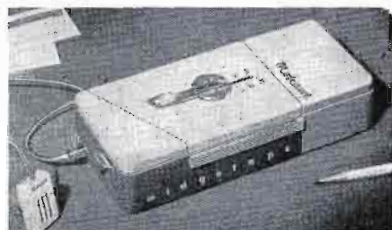
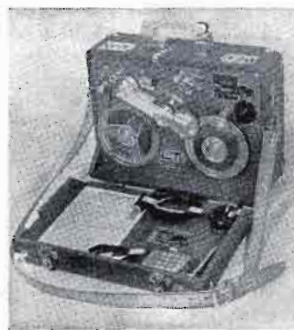

Midgetape Pocket Recorder

Weights only $3\frac{1}{8}$ lbs. Size: $8\frac{1}{2}$ "x $3\frac{7}{8}$ "x $1\frac{1}{8}$ ". Motor battery lasts 45 hours and amplifier battery 100 hours. Records at $1\frac{1}{8}$ " sec. For voice only. Manual rewind in less than 1 minute. Uses special tape listed below. To play back on standard broadcast tape unit, procedure is to re-record from midget tape to standard recorder. Ideal for roving reporter and pickups where fast action and minimum equipment required.

Model MT-100 Complete recorder/playback with 1 hour tape cartridge, crystal mic, ear phone and batteries\$249.50
 Model MT-2 Carrying case for MT-100 14.75
 Model MT-8 Conference desk microphone 14.50
 Model MT-11 Amplifier B battery 3.95
 Model MT-12 Motor and filament battery 11.95
 Model MT-13 Microphone extension cable, 12-foot 9.95
 Model MT-14 One-hour tape cartridge 11.50
 Model MT-15 One-hour reel of tape 2.50

Gates
 Direct Factory
 Sales Engineers
 Are
 Everywhere

Berlant Stereo-Monaural

Records either monaural or stereo at both $7\frac{1}{2}$ " and 15" sec. Includes separate drive mechanism, two amplifiers with VU meters and dual input for either one or two channel recording. Contains 2 half-track erase heads, stacked binaural record and playback heads. Accessories such as plug-in transformers and mixers are same as BRX-1 on preceding page. Complete playback facilities also included.

Model SBX-4 Recorder \$845.00

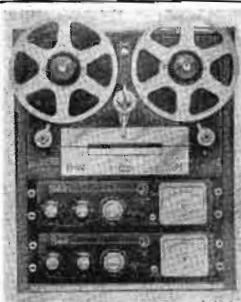

GATES

157

PENTRON TAPE RECORDERS

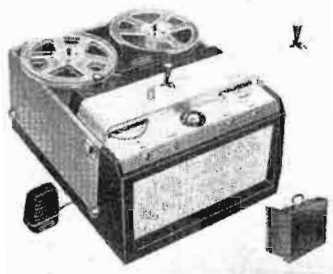

Pacemaker Model T90

In modestly priced tape recorders, Gates engineers feel the Pentron line offers top dollar value. This model records and plays back at both $7\frac{1}{2}$ " and $3\frac{3}{4}$ ". Has 50-10,000 cycle response ($7\frac{1}{2}$ ") and very low flutter. Will record up to 3 hours using long play tape at half track. Has dual (woofer and tweeter) self-contained loudspeakers. Features selector lever control of tape mechanism. Rugged carrying case and hand/desk microphone standard equipment.

Model T90 Half Track	\$149.50
Model T90 Full Track	157.00

Pentron Basic System

Includes basic tape mechanism and preamplifier with dual Hi-Z input. TAPE MECHANISM has single control selecting play—fast forward and rewind. Operates at $7\frac{1}{2}$ " or $3\frac{3}{4}$ ". Has separate record-playback and erase heads. Shaded 4-pole motor. AMPLIFIER supplies preamplification for Hi-Z mic and Hi-Z bridging (unbalanced) input plus equalization, bias erase oscillator and VU meter. Output Hi-Z but may be Lo-Z by adapting to any good plate to line transformer. For low cost recording and playback, this equipment is real dollar value.

Model MP-2: Complete recorder amplifier and portable case, as illustrated, for half track	\$149.95
Model MP-2F: Same as above but full track	157.45
Model TM-56: Tape mechanism, half track, panel size $10\frac{7}{8}$ " x $9\frac{3}{4}$ "	69.95
Model TM-56F: Same as TM-56 only full track	77.45
Model P-4: Preamplifier	59.95

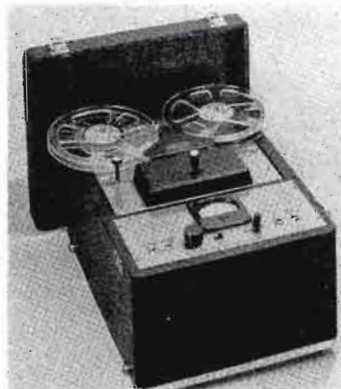

Pentron Clipper

For real low cost tape recording, this model performs well. Ideal for office, home, auditioning, e.t.c. Operates at $7\frac{1}{2}$ " and $3\frac{3}{4}$ ", providing up to 3 hours continuous with thin tape. Has 4-watt amplifier, loudspeaker, hand microphone, slot tape loading, separate volume and tone controls, two input and two output jacks, automatic braking and plays in any position.

Model RWN Recorder for half track operation	\$109.50
Model RWN-F Recorder for full track operation	117.00

3 Speaker Pentron Hi-Fi

This model is used where unusual loudspeaker reproduction is desired. Has dual inbuilt woofer speakers and separate tweeter for full range. Includes hand microphone, 10 watt Hi-Fi amplifier, automatic index counter, LC crossover network at 1000 cps. Single lever control for play—fast forward—record and rewind. Operates at $7\frac{1}{2}$ " and $3\frac{3}{4}$ ". Range 40 to 12,000 cycles. Records up to 3 hours at $3\frac{3}{4}$ " half track. Excellently cased for portability.

Model HF-400: Complete recorder, half track	\$187.50
Model HF-400F: Complete recorder, full track	195.00



SCOTCH BRAND RECORDING TAPE

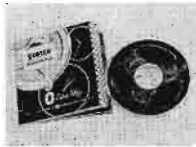

LEGEND

Type 111—Widely used plastic base . . . red oxide coating.
 Type 120—New high output plastic base tape . . . green coded.
 Type 190—New thin tape . . . 50% more recording time per reel.
 Type 150—Similar to Type 190 but for wider temperature and humidity.
 Type 111AM—Similar to Type 111 but for wider temperature and humidity.
 Type 120AM—Similar to Type 120 but for wider temperature and humidity.



PRICES

TYPE	SIZE	1 to 11 1 to 5*	12 or more 6 or more*
111A-1.5	1/4" x 150' plastic reel	\$.57	\$.51
111A-3	1/4" x 300' plastic reel	1.00	.90
111A-6	1/4" x 600' plastic reel	1.58	1.46
111A-12	1/4" x 1200' plastic reel	2.45	2.28
111AP-12	1/4" x 1200' prof. plastic reel	3.47	3.12
111A-24H	1/4" x 2400' NARTB hub	5.67*	5.10*
111A-24R	1/4" x 2400' NARTB 10 1/2" reel	7.27*	6.54*
111A-24RPS	1/4" x 2400' RETMA 10 1/2" plastic reel	7.27*	6.54*
120A-3	1/4" x 300' plastic reel	1.17	1.05
120A-6	1/4" x 600' plastic reel	2.34	2.10
120A-12	1/4" x 1200' plastic reel	3.67	3.30
120A-24H	1/4" x 2400' NARTB hub	6.67*	6.00*
120A-24R	1/4" x 2400' NARTB 10 1/2" reel	8.57*	7.71*
120A-24RPS	1/4" x 2400' RETMA 10 1/2" plastic reel	8.57*	7.71*
190A-9-100G	1/4" x 900' plastic reel	2.34	2.10
190A-18-100G	1/4" x 1800' plastic reel	3.67	3.30
190A-36R-100G	1/4" x 3600' NARTB 10 1/2" reel	8.57*	7.71
190A-36RPS-100G	1/4" x 3600' RETMA 10 1/2" plastic reel	8.57*	7.71*
150-9	1/4" x 900' plastic reel	2.93	2.64
150-18	1/4" x 1800' plastic reel	5.30	4.77
150-36H	1/4" x 3600' NARTB hub	10.67*	9.60*
150-36R	1/4" x 3600' NARTB 10 1/2" plastic reel	11.97*	10.77*
150-36RPS	1/4" x 3600' RETMA 10 1/2" plastic reel	11.97*	10.77*
111AM-6	1/4" x 600' plastic reel	3.50	3.15
111AM-12	1/4" x 1200' plastic reel	6.50	5.85
111AM-24H	1/4" x 2400' NARTB hub	11.30*	10.17*
111AM-24P	1/4" x 2400' NARTB 10 1/2" reel	13.20*	11.88*
111AM-24RPS	1/4" x 2400' RETMA 10 1/2" plastic reel	13.20*	11.88*
120AM-6	1/4" x 600' plastic reel	3.84	3.45
120AM-12	1/4" x 1200' plastic reel	7.17	6.45
120AM-24H	1/4" x 2400' NARTB hub	12.64*	11.37*
120AM-24R	1/4" x 2400' NARTB 10 1/2" reel	14.54*	13.08*
120AM-24RPS	1/4" x 2400' RETMA 10 1/2" plastic reel	14.54*	13.08*
41 1/2 S	Splicing tape 1/2" x 150'35	—
41 3/4 S	Splicing tape 3/4" x 150'44	—
41 1/2 L	Splicing tape 1/2" x 66'69	—
41 7/32 L	Splicing tape 7/32" x 66'52	—
48 3/4 S	Write-on tape 3/4" x 100'*23	—
48 3/4 L	Write-on tape 3/4" x 66'**	1.14	—
	* Metal utility dispenser.		
	** For use on plastic hand or desk dispenser.		
RB-3	3" (150') empty reel, box, mailing carton17	.15
RB-4	4" (300') empty reel, box, mailing carton37	.33
RB-5	5" (600') empty reel, box, mailing carton44	.39
RB-7	7" (1200') empty reel, box, mailing carton50	.45
RB-7B	7" (1200') plastic professional, reel, box, carton84	.75
RB-10 1/2 M	10 1/2" (2400') NARTB metal reel, box, carton	3.00	2.70
RB-10 1/2 RPS	10 1/2" (2400') RETMA plastic reel, box, carton	3.00	2.70
43-1.5	1/4" x 150' leader, timing tape40	.36

ASSORTING PRIVILEGE: Various items and lengths of magnetic tape are assortable in standard packages to make quantity. When quantity discount established with tape, same discount applies to empty reels, boxes and cartons.

DISC RECORDERS



Presto K-10

One of the real popular Presto disc recorders, fully portable in one case 19½"x15½"x14". Records and plays back at 78, 45 and 33½ RPM. Response: 50-8000 cps. Standard feed pitches are 112 and 224 lines per inch, either inside to out or vice versa. Comes ready to use other than microphone (see microphone section of this catalog for wide variety). — Here is a recorder that will do a professional job for either standard or LP recordings. For 115 volts, 60 cycles.

Model K-10 Disc Recorder \$366.50

Model K11 now replaces above K-10. — See Price List.

Presto Model 6N

The "Mr. Recorder" of the disc recording field. Illustrated in portable case but floor cabinet available for permanent use. Designed specifically for broadcasting station and recording laboratory. When used with the A93 amplifier, listed below, a wide variety of recording curves are possible and will meet all currently popular standards. Records at 33½ or 78 RPM and simple adapter converts to 45 RPM. Feed screw supplied is 112 lines per inch inside to out. Feed screws of 96, 104, 120 or 136, either inside to out or vice versa, are available along with microgroove pitches of 244, 256 and 288. For 115 volts, 60 cycles. Cutting head impedance, choice of 15 or 500 ohms. Playback pickup 500 ohms.

Model 6N Recorder, chassis only \$728.00

Model 6N Recorder in portable case 773.00

Model 6N Recorder in floor cabinet 859.00

Adapter for 45 RPM 10.00

Microgroove feed screws, choice 244, 256 or 288.. 59.50



A93 Amplifier

A new recording amplifier for use with the 6N recorder, listed above, as well as the 8D and 8D6 models to the right. Provides 3 curves of: (a) flat, (b) 78 and (c) NARTB. A radius switch is provided, permitting the operator to insert an equalizer circuit for loss in high frequency response in center of the disc. Includes VU meter, range control and master gain. Power output 30 watts.

Model A93 Amplifier
with tubes \$293.25

Gates Phone Numbers

Quincy, Ill.	BA 2-8202
New York	MU 7-7971
Washington	ME 8-0522
Houston	CA 8-8536
Atlanta	ELG 0369
Los Angeles	HO 2-6351

Presto 8D6 Direct Drive Recorder

For the finest precision built recorder, this direct drive model has no superior. Has adjustable pitch inside-out or outside-in of 88, 96, 104, 112, 120, 128 or 136 LPI. Noise level better than 50 db below program level. Microscope has magnification 40 power, area in focus — 7 grooves. Fully adjustable and grooves are illuminated. Built around twin motor, direct gear driven mechanism with synchronous motors. Records at 78.26 or 33½ RPM. Presto 1D cutting head supplied.

Total weight packed, 625 lbs.

Size: 35"x23"x53".

For 115 volts, 60 cycles.

Other voltages and frequencies available at slight extra cost as well as facility for 45 RPM and microgroove.

Model 8DG Recorder with floor cabinet . \$2787.00

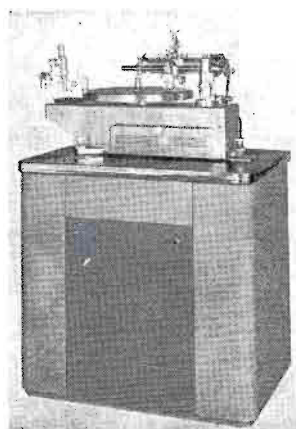

DISC RECORDERS — ACCESSORIES

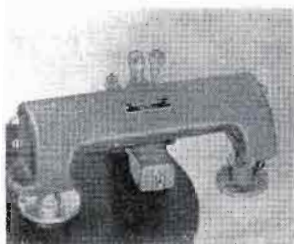

M12

Overhead Mechanism

Designed for use with TR12H recording turntable or any comparable 12" recording turntable. Automatically lifts cutter head as lead screw approaches center of disc. Lead screws easily interchangeable. Locked grooves easily made. Cutter impedance 8 ohms and of good quality.

M12 Overhead with 8 ohm cutter	\$109.95
M12-108 Feed screw 108 lines	17.95
M12-120 Feed screw 120 lines	17.95
M12-216 Feed screw 216 lines	27.95
M12-240 Feed screw 240 lines	27.95

Presto 1D Cutting Head

Recognized as the finest in the disc recording field. Very low distortion and flat response from 50-10,000 cycles. Available in 16 or 500 ohms. Illustrated on Presto recorders listed on previous page. May be used on Model V listed above, or any disc recorder.

1D-16 Recording head	
16 ohms	\$188.00
1D-500 Recording head	
500 ohms	188.00

Recording Stylus

Professional type, disc tested, for best possible recordings. State whether long or short shank when ordering.

Model 14 (87°), sapphire, shank dural	\$4.50
Model 14 (70°), sapphire, shank dural	4.50
Model 20 (microgroove), sapphire, shank dural	4.50
Model 202, sapphire, shank brass	3.60
Model 34, stellite, shank brass	1.20



Gibson Girl Tape Cutter Splicer

Cuts two rounded indentations in the tape splice. Leaves edges of tape which contacts recorder, free of adhesive. Makes professional splices in 5 seconds. May be removed from base and mounted directly on tape recorder, if desired. Model TS-4DLX Cutter splicer..\$8.70

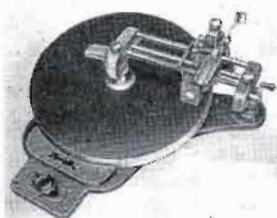

Rek-O-Kut Model V

Features Mastermatic, self-lacking, instantaneous speed shift. For recording up to 17" discs at 78 and 33 1/2 RPM. Use of V-103A adaptor allows 45 RPM. Also equipped with hysteresis synchronous 115 volt, 60 cycle motor. Platter cast aluminum. Chassis L-Beam cast iron. Size: 20" square, 2 1/2" above motorboard, 5" below.

Model V 16" recording turntable (less overhead) ..	\$215.00
Model M55 overhead mechanism (less cutter) ..	200.00
Model 103A 45 RPM adapter	8.00

NOTE: M55 supplied with 120 line outside-in feed screw. Feed screws for 105, 120, 135, LPI available at \$37.50 each. Feed screws for 210, 240 and 270 LPI, \$47.50 each. Available outside-in or inside-out.



TR12H Recorder

For professional recording up to 13 1/2" discs. Chassis of cast aluminum, drilled for M12 overhead mechanism listed to left. Idlers of neoprene for maximum traction. Size: 14 1/2" x 16 1/4". Height above motorboard 1 3/8". Below motorboard 5". Records at 78 or 33 1/2 RPM. Use of T-103A adaptor for 45 RPM.

Model TR12H Recorder (less overhead)	\$139.95
Model M12 Overhead with 108 outside-in feed screw	109.95
Model T-103A adapter for 45 RPM	8.00

Audio Discs

Available in three qualities. RED LABEL is the very best and standard throughout the industry for broadcasting, sound and movie studios. YELLOW LABEL, a popular choice for general purpose recording that is only exceeded by the red label quality. REFERENCE LABEL, a good disc used for test cuts and where slight imperfections will not be noticeable, as recordings with higher background level such as sports, etc.

Type	7"	8"	10"	12"	16"
Red Label Double Face	\$.77	\$.60	\$.84	\$1.38	\$2.53
Red Label Single Face	—	—	—	1.12	1.99
Yellow Label Double Face	—	.50	.67	1.12	1.99
Reference Label Double Face	—	—	.58	.85	1.51

NOTE: 7" discs have 1 1/2" diameter center hole for 45 rpm. Prices shown in lots of 25. Add 11c for broken lots.



Industrial Tape Splicer

Designed for tape sizes up to one inch wide. For rapid editing and repairing of computer, TV, industrial and special purpose tapes. Cuts two tape ends diagonally to butt together accurately. Trims and splices parallel to tape. Edges remain free of adhesive. Carriage has two knob controlled operation positions, one for miter cutting, and one for indented trim cut.

TS-250 for 1/4" tape	\$55.00
TS-500 for 1/2" tape	55.00
TS-625 for 5/8" tape	55.00
TS-750 for 3/4" tape	55.00
TS-1000 for 1" tape	55.00

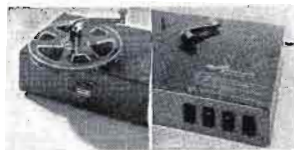

Model N7 Model N14

Minnesota Tape Eraser

A carefully engineered magnetic device to eliminate all signals and background noise from entire reels of tape in a few seconds. Even suggested for use with new tape to eliminate inherent noise. Manufacturer states that erase leads on standard recorders do not begin to eliminate noise and background that is possible with the use of these models. Operates from 115 volts, 60 cycles. Model N7 is for maximum of 7" reels. N14 is for maximum of 14" reels. — Every broadcaster using tape should have one of these units.

Model N7	\$49.50
Model N14	86.75

MICROPHONES — ACCESSORIES



660



670-A



671-A



M-11 System

Altec Model 660

A rugged dynamic microphone for all types of broadcasting. Response: 30-12,000 cps. Output level: -58 dbm/10 dynes/cm. Size: 4"x1 3/4" diameter with 5/8"-27 swivel head. 660-A is 30 ohms output. 660-B is 30, 150/250 or 20,000 ohms.

Model 660-A	\$45.00
Model 660-B	50.00

Altec Model 671-A

A velocity microphone with high signal to noise ratio, extremely low hum pickup and wide response. Output: 30/50, 150/250 ohms at -56.5 dbm/10 dynes/cm. Response: 30-16,000 cycles. Size: 4 1/2"x2 1/4"x3 3/8" deep. 5/8"-27 swivel head. Finish, gray.

Model 671A	\$75.00
------------------	---------

Shure 525



A fine slenderized, dynamic omni-directional microphone of broadcast quality. Non-reflecting baked bronze finish. Size: 8 1/2"x1" diameter. 20' cord supplied. Response: 40-15,000 cps. Output: 50, 150/250 ohms at 61 dbm per 10 microbar sig. For desk stand, see Model 533 listed below.

Model 525 microphone	
	\$120.00

Desk Stand

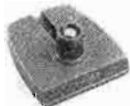

For either 525 or 333 microphones listed above. Non-reflecting, small and rugged.

Model 5-33	\$9.00
------------------	--------

Microphone Accessories

This catalog lists complete accessories for microphones such as stands, connectors, call letter plates and cable. Please refer to Index.

Altec Model 670-A

A cardioid microphone with 3 directional patterns adjustable from back of microphone. Screwdriver switch under name plate selects desired output impedance. Response: 30-15,000 cps. Output: 30, 50, 150/250 ohms at -58 dbm/10 dynes/cm. Size: 6 1/2"x2 1/2"x3 3/8" deep. 5/8"-27 swivel head. Finish, gray.

Model 670-A	\$135.00
-------------------	----------

Altec M-11 Microphone System

The ultimate in quality. Omni-directional. Consists of 21-C condenser microphone, 150A base and P518A power supply. Response: 20-15,000 cps. Output: -48 dbm/10 dynes/cm. Output impedance: 30, 150/250, 500/600 ohms. Finish, satin black. Tubes: one 6AU6.

Model M-11 complete	\$230.00
152A cable set (25' for desk or floor stand)	30.00

Shure 333



One of the outstanding ribbon cardioid microphones with Fig. 8 pattern on market today. Has music-voice switch, anti-blast filter screen, self-adjusting swivel, multi-impedance switch, line rubber shock mount. Response: 30-15,000 cps. Output: 50, 150/250 ohms at 59 dbm per 10 microbar signal. Baked bronze, non-reflecting finish. 5/8"-27 thread. Size: (head only) 1 1/8"x3 9/16"x1 3/4" deep.

Model 333	\$150.00
-----------------	----------

Altec Exchange Prices

Any unserviceable Altec microphone listed below will be exchanged for a new one if in good condition, currently being manufactured and sent prepaid.

MODEL	Exchange Price
21B microphone (exchange for 21C)	\$32.00
21C microphone	25.00
21D microphone	25.00
660-A microphone	22.50
660-B microphone	23.50
670-A microphone	21.00
671-A microphone	16.50

MICROPHONES — ACCESSORIES



Shure Unidyne

Stated as largest selling microphone throughout the world. 55-5 recommended for remote pickups, theatre stage, PA, etc., while 556-5 is recommended for radio/TV studio and professional recording. Both models have impedance selector switch for 50, 150/250 ohms and Hi-impedance. Supplied with 20' cable. Response: 40-15,000 cps. Output: approximately 60 dbm below microbar signal. $\frac{5}{8}$ "-27 thread.

Model 55-5\$47.70
Model 556-5 72.00



Electro-Voice 655-C

Frequency response 40-20,000 cps. Output level -55 db. Has widest range response. Used in many laboratories as test standard. Excellent level affords high signal-to-thermal noise ratio. Pop-proof grille stops blasts. Can be used on stand, in hand or on boom. Easily concealed in studio props. Acoustalloy diaphragm. Impedance 50, 150 and 250 ohms. Impedance easily changed at internal terminal board. Cannon UA-3 connector. Clamp-on stand mount included with $\frac{5}{8}$ "-27 thread and $\frac{1}{2}$ " pipe thread adapter. Size: 10 $\frac{1}{2}$ " long without connector, 1" diameter. 18' cable. Net wt, 11 oz.

Model 655-C \$120.00



Electro-Voice 650

An individually laboratory tested unit with non-metallic diaphragm and substantially flat from 40-15,000 cps. Ideal for fine studio or remote pickup. Output: 50 and 250 ohms at -48 db, 10 dynes/cm omni-directional at low frequencies. Satin chrome finish, shock mounted, $\frac{5}{8}$ "-27 thread, 18' of cable. Size: 2 $\frac{1}{4}$ " diameter, 5 $\frac{1}{4}$ " high including shock mounting.

Model 650 \$90.00

Electro-Voice 630

High output dynamic. Response: 60-11,000 cps. Output: -55 db. Tilt-tilting head, satin chrome finish. Size 2"x6 $\frac{1}{4}$ " overall. Available in 50, 250 or Hi-impedance as specified when ordering.

Model 630 \$28.20



Electro-Voice 605



Durable Dynamic. For dependable, general-purpose use. Response 65-7500 cps. Output level -55 db. Nondirectional, becoming directive at higher frequencies. Acoustalloy diaphragm. Head at 22° fixed tilt. Built-in MC-1 connector. Satin chrome. Choice of 50, 250 ohms or Hi-Z as specified when ordering. Low impedance not balanced to ground.

Model 605 \$19.50



Shure Gradient

Two models of this popular bi-directional microphone are available. Include anti-blast filter screen, non-reflecting bronze finish, multi-impedance output switch for 50, 150/250 ohms and Hi-impedance. Output: approximately 59 dbm at 10 microbar signal. This microphone may be used on both front and back and dead on sides. Model 300 response: 40-15,000 cps. Model 315: 50-12,000 cps. $\frac{5}{8}$ "-27 thread. Supplied with Cannon connectors.

Model 300 \$90.00
Model 315 51.00

Electro-Voice 654

Slim-Trim Broadcast Dynamic. Frequency response 50-16,000 cps. Output level -55 db. Quality matches closely that of model 655; microphone is an excellent utility unit for all commercial uses. Recessed selector provides 50 or 250 ohms impedance. Pop-proof head. Acoustalloy diaphragm. TV gray enameled finish. Built-in Cannon XL-3 connector. $\frac{5}{8}$ "-27 thread, 18' cable. Size: 10" long with stud, 1" diameter. Net wt. 15 $\frac{1}{2}$ ozs.

Model 654 \$57.00



Electro-Voice 635

Most popular in remote pickups; but, also excellent for announcing and studio. A truly fine, low priced, dynamic microphone. 60-13,000 cycle response. -55 db output. Impedance selector for 50 or 250 ohms. $\frac{5}{8}$ "-27 thread. 18' cable.

Model 635 \$45.00



Electro-Voice 646

Small, versatile for desk, chest or hand use. Response: 40-10,000 cps with recessed screw-in grill to adjust high response to suit application. Output: 150 ohms at -55 db, omni-directional. Size: 6 $\frac{1}{4}$ "x1 $\frac{1}{8}$ ".

Model 646 \$84.00
Model 416 (desk stand) 3.00

Electro-Voice 611



"Mercury" Dynamic. A traditionally styled fine performing dynamic microphone for general sound pickup. Response 50-8000 cps. Output -55 db. Nondirectional. Acoustalloy diaphragm. Tilttable head. On-Off switch. Built-in MC-3 connector. $\frac{5}{8}$ "x27 thread. Satin chrome finish. Available in 50, 150 and 250 ohms or Hi-Z as specified when ordering. Low impedance balanced to ground. Size: 2 $\frac{3}{8}$ "x3 $\frac{1}{8}$ "x6 $\frac{1}{4}$ ". 18' cable supplied.

Model 611 \$23.70

MICROPHONES — ACCESSORIES

Electro-Voice 666



Among the best in cardioid microphones. Wide 40-15,000 cps response. Permits close talking without bass accentuation. Variable 50, 150, 250 ohm output. Designed to operate on boom, desk or floor stand. Increases working distance over pressure microphones 1.7:1 due to reverberation reduction. Cast aluminum, case finished in TV gray. Built-in Cannon VAS connector. Clamp on stand mount with $\frac{5}{8}$ "-27 connector and 20' cable supplied. Size: $7\frac{1}{2}$ " long, $1\frac{3}{4}$ " diameter.

Model 666 \$147.00
420 Desk Stand 12.00

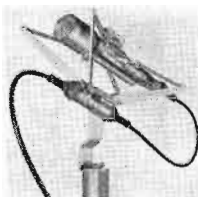

Suspension Mount

Light weight suspension shock mounting made for boom mounting of microphones of 1" diameter such as the 666. Has pigtail cable connection with VAS connectors.

Model 366... \$24.00

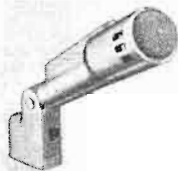

664 Electro-Voice Cardioid

A good cardioid in the medium price field that may be used for close talking without booming. 60-13,000 cps response. Output: -55 db at 150 ohms and Hi-impedance. Size: $7\frac{3}{16}$ " long, $1\frac{1}{8}$ " diameter. 18' cable supplied. $\frac{5}{8}$ "-27 thread.

Model 664 \$47.70

Blast Filter



Acoustically treated grill stops wind and breath blasts in dynamic microphones. Does not affect response. Fits over Electro-Voice 630, 635 and 605 microphones.

Model 335 \$3.30

Cardioid Model 665

Similar to 666 in performance but for slightly less exacting requirements. Response: 50-14,000 cps. Output: 50 and 250 ohms. Recessed switch permits quick selection of either output impedance. Size $7\frac{3}{16}$ " x $1\frac{1}{8}$ " diameter. Non-reflecting gray finish. 18' cable. $\frac{5}{8}$ "x27 thread.

Model 665 \$78.00



Slim Dynamic

Omni-directional, medium priced, good performer. Response: 65-9000 cycles. Output: -56 db with either high or low impedance output. Tilttable head, $\frac{5}{8}$ "-27 thread. Satin chrome finish. Size: $7\frac{1}{2}$ " x $1\frac{5}{16}$ " diameter. 18' cable.

Model 623 \$29.70



"Slimair"

A fine, general purpose microphone for hand or stand. Omni-directional. High or low impedance output at -55 db. Response: 60-13,000 cps. Pop - proof head. On - Off switch. $\frac{5}{8}$ "-27 thread and 18' cable.

Model 636
\$42.00



Desk Stand

Model 418 for Electro-Voice 611, 623, 630, 635, 636.
Model 419 for Electro-Voice 650, 654, 664, 665.
Gray finish.

Model 418 \$9.00
Model 419 9.00



Shock Mount



Dual external shock mount to prevent external vibrations. Mounts to $\frac{5}{8}$ "-27 microphone thread and stand. Size: $1\frac{1}{2}$ " x $3\frac{3}{8}$ ".

Model 345 \$7.80

Shock Mount

Same as above only designed specifically for Electro-Voice Model 666 microphone.

Model 346 \$7.80

American D330 - D332

A real performing ribbon-cardioid. Supplied with 25' cable. $\frac{5}{8}$ "-27 thread. D330: 50-8000 cps response, 50, 250 ohms and Hi-impedance at -53 db. D332: 40-15,000 cps response, 50, 150, 250 ohms output at -86 db. Size: $6\frac{1}{2}$ "x2" diameter.

Model DR-332 \$ 51.00
Model DR-330 150.00
Model ND desk stand (illustrated) 6.00



American D22 - D33

Two fine omni-directional dynamic microphones. Size: $8\frac{1}{4}$ "x1" diameter. $\frac{5}{8}$ "-27 thread. 25' cable supplied. Model D22: 100-8000 cps response, output -52 db at 50 or Hi-impedance. Model D33: 40-15,000 cps. response, output 50, 250 ohms at -86 db.

Model D22 \$45.00
Model D33 75.00
Model ND desk stand (illustrated).. 6.00



MICROPHONES — ACCESSORIES



U-9S



211



53



57

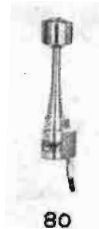

80

Turner U-9S

Here is a rugged dynamic for recovers, announcing, etc. Output: —52 db at 50, 200 ohms and Hi-impedance. Response: 80-9000 cps. $\frac{5}{8}$ "-27 thread, adjustable swivel, 20' cable, gun-metal finish.

Model U-9S \$29.70



50-DTV Dynamic

A wide range 50-15,000 cps microphone, omni-directional with —55 db output at either 50 or 200 ohms. Aluminum alloy diaphragm, magnetically shielded transformer, $\frac{5}{8}$ "-27 thread, hinged stand coupler, weight 16 ozs., 20' cable and comes complete with desk stand as illustrated. Size: $6\frac{1}{2}$ "x $1\frac{3}{8}$ " diameter. Finish, satin black.

Model 50-DTV \$75.00

DS-7 Desk Stand

An adjustable stand with chrome tube and cast, felt covered base. Adjustable 8" to 13" with $\frac{5}{8}$ "-27 thread.

Model DS-7 \$3.00

DS-10 Desk Stand

Neat and streamlined with concealed cable feature. $\frac{5}{8}$ "-27 thread and base design makes tipping almost impossible.

Model DS-10 \$3.00

No. 211 Dynamic

A good, modestly priced dynamic with high sensitivity. 50-10,000 cps response and 50, 200 ohms and Hi-impedance output at —54 db level. 90° tilting head, $\frac{5}{8}$ "-27 thread and 20' cable. Made by Turner.

Model 211 \$25.50

Slim-Trim 57

For a 50-13,000 cycle performer with —55 db output, either low or Hi-impedance, this modestly priced microphone will fit many needs. Black satin finish, built-in shock mount, 20' cable and $\frac{5}{8}$ "-27 thread. Size: $8\frac{3}{4}$ "x $1\frac{1}{8}$ " diameter.

Model 57 \$41.40

BL-6 Desk Stand 4.50

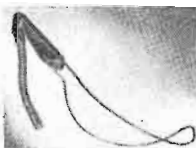

Turner Third Hand

Slip over head, wear as a necktie. Holds microphone close to lips for sports or audience type shows. Has $6\frac{1}{4}$ " flexible gooseneck. $\frac{5}{8}$ "-27 thread. Finish, black.

Model 3H \$3.00

Bracket Clamp

Clamp to pulpit, side of desk, etc., to hold microphone. $\frac{5}{8}$ "-27 thread. Length of chrome plated tube is 6".

Model BC-1 Clamp \$2.10

DS-5 Desk Stand

Same as DS-7 but non-adjustable. Height 6" with $\frac{5}{8}$ "-27 thread.

Model DS-5 \$1.80

Crystal Type 33

A real good crystal microphone with crisp voice quality. Response: 60-9000 cps. Two element, moisture sealed crystal and mechanical shock proofing. Output: —52 db at Hi-impedance. Satin chrome finish, 90° tilting head, $\frac{5}{8}$ "-27 thread.

Model 33C \$16.17

Miniature 80

Hide in palm of hand. Weighs 4 ozs. Crystal Hi-impedance type, 80-7000 cps at —54 db. Blast and shock proof. Bimorph moisture sealed crystal. Illustrated on C-4 stand.

Model 80 \$9.57

C-4 Desk Stand 3.45

Shure Ranger



Designed for good voice intelligence for such things as radio communications, voice PA announcements, etc. Output: —47 db at choice of 150-250 ohms or Hi-impedance. Switch in side for push-to-talk. Supplied with 8' cable.

Model 505-B (Low imp.) \$19.20

Model 505-C (High imp.) 19.20

TS-6 Banquet Stand

Base diameter 8" and adjustable 18" to 32". Chrome tube with $\frac{5}{8}$ "-27 thread. Full grip velvet action adjustment.

Model TS-6 \$5.40



DS-7



DS-10



BC-1



DS-5



TS-6

MICROPHONES — ACCESSORIES



D-300

American D-300

Convenient, light weight and durable. Weighs only 6 ounces. Response: 50-12,000 cps. Black aluminum non-glare finish. Output: 250 ohms. $\frac{5}{8}$ "-27 thread. 25' cable supplied. Model S-905 desk stand, 4 $\frac{1}{2}$ " square, 1 9/16" high. WS-2 wind screen, optional, makes microphone effective in winds up to 20 miles per hour.

Model D-300 Microphone	\$78.00
Model S-905 Stand	2.70
Model WS-2 Wind Screen	22.50



WS-2

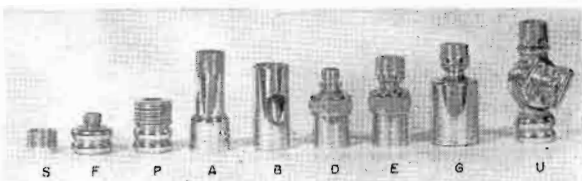

Adaptors — Swivels

No.	Male	Female	Fig.	Price
101	$\frac{1}{8}$ " pipe	$\frac{5}{8}$ "-27	F	\$.45
107	$\frac{1}{2}$ " pipe	$\frac{3}{8}$ "-27	P	.60
108	$\frac{1}{2}$ " pipe	$\frac{1}{2}$ "-27	P	.60
109	$\frac{5}{8}$ "-27	$\frac{1}{2}$ "-27	S	.30
120	$\frac{3}{8}$ "-27	$\frac{1}{8}$ " pipe	S	.30
112	$\frac{3}{8}$ "-27	$\frac{1}{2}$ " pipe	A	.90
118	$\frac{5}{8}$ "-27	$\frac{5}{8}$ "-27	B	.90
132	$\frac{3}{8}$ "-27	$\frac{3}{4}$ "-27	A	.60
145	$\frac{1}{2}$ " pipe	$\frac{3}{4}$ "-27	P	.60
103	$\frac{1}{8}$ " pipe	$\frac{5}{8}$ "-27	D	1.20
110	$\frac{3}{8}$ "-27	$\frac{3}{8}$ "-27	E	1.50
117	$\frac{3}{8}$ "-27	$\frac{3}{8}$ "-27	U	2.25
119	$\frac{1}{8}$ " pipe	$\frac{5}{8}$ "-27	G	1.65
121	$\frac{3}{8}$ "-27	$\frac{3}{8}$ "-27	G	1.95



Turner Lavalier

Only 4"x1" diameter, this 60-13,000 cps microphone comes with support clip and neck cord. Can easily be hidden behind necktie. Output: -57 db at either 50 or 250 ohms. Supplied with 25' cable. Weight, 3 $\frac{1}{2}$ ozs. Finish in non-glare gray.

Model 58-A	\$34.20
G-4 Desk Stand for 58-A	3.45

Stephens Wireless Microphone

Where direct microphone connection is impractical such as encountered in difficult stage settings, the Stephens wireless microphone, no larger than a pack of cigarettes, provides the same quality results as the best of microphones. — Receiving equipment is packaged in two leatherette carrying cases for portability. Consists of microphone, pocket battery pack, plus receiver and power supply. Output impedance of receiver feeds conventional mixing system.

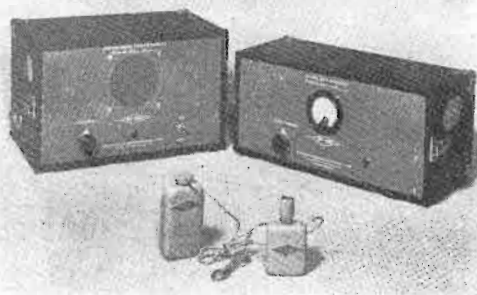

SPECIFICATIONS

TRANSMITTER: 30-12,000 cps. Tubes: two 5672. Size: 3 $\frac{3}{8}$ "x2"x1" deep.
BATTERY PACK (Transmitter): Size: 3 $\frac{3}{8}$ "x2"x1" deep. Contains 2 each General RG-1 and Burgess U-20 batteries. Battery life continuous, 2-3 hours.
RECEIVER: 9 $\frac{1}{4}$ "x15 $\frac{1}{2}$ "x7 $\frac{1}{4}$ " deep. Tubes: Four 6CB6, two 6AB4; one each 6AL5, 12AU7, 12AY7, 12AT7. Output: -10 db at 600 ohms. 30 db limiting with 5 microvolts input. Antenna: 4-section $\frac{1}{2}$ wave dipole with 50' RG58U cable.
POWER SUPPLY: Provides full power for above receiver. Tubes: one each 12AU7, 6AQ5. Size: 10 $\frac{1}{2}$ "x14"x8 $\frac{1}{4}$ ". For 105-125 volts, 50/60 cycles.

Model GR-17 Wireless Microphone \$980.00

MICROPHONE STANDS



SK-1

Sky Hook

For attaching microphone to ledges, overhead pipes or any place a clamp can be attached. $\frac{5}{8}$ "-27 thread. Tube 3" long.

Model SK-1 \$2.10



SW-1

SW-1 Swivel

When used, any microphone may be locked into any angle on a floor or desk stand. Chrome finish. $4\frac{1}{2}$ " long. $\frac{5}{8}$ "-27 thread.

Model SW-1 \$2.40

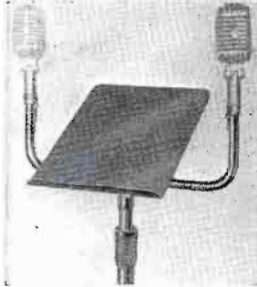

TB-1

Duplex Mike Mount

Attaches to banquet stand as illustrated. Permits use of two microphones on single stand and complete composition copy stand $9'' \times 11''$. Finish, chrome. $\frac{5}{8}$ "-27 thread.

TB-1 Duplex (less banquet stand) \$6.00
 TS-7 Banquet Stand .. 6.00

CH-1 Cable Hanger

A real need on every microphone stand. Fits all tubes $\frac{7}{8}$ " to $1\frac{1}{4}$ " diam. Chrome finish.

Model CH-1 \$1.50



CH-1

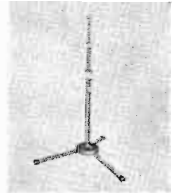

CS-33



BB-1

Demountable Stand

A completely demountable floor stand for easy, light weight portability, yet unusually strong and sturdy. Adjusts from 26-64". Finish chrome. $\frac{5}{8}$ "-27 thread. Rubber cushioned feet. Weight 4 lbs. Can be collapsed to length of $22\frac{1}{2}$ ".

Model CS-33 \$7.05

BB-1 Boom Bracket

Attaches to any microphone stand. $\frac{5}{8}$ "-27 thread. 32" long, chrome plated. May be locked into position, accommodating various microphone weights.

Model BB-1 \$4.50

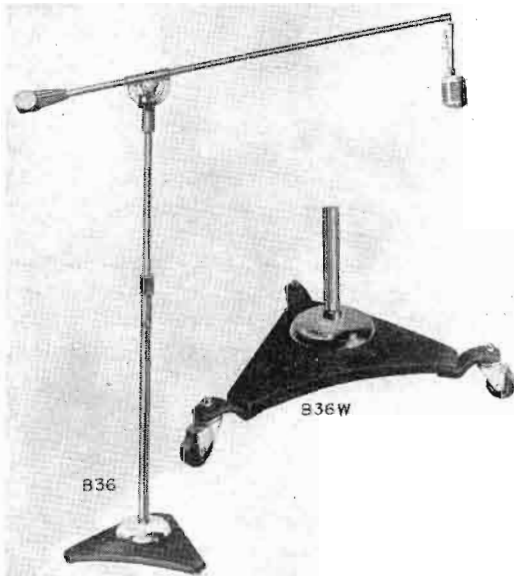

B36

B36W

Model BS-36 Boom Stand

Floating action, safety air lock cushion prevents accidental slippage. Gyromatic swivel assures microphone hanging in desired position. Boom length, 62". Vertical adjustment: 48-72". Base diameter: 17". Snap-on hangers provided to hold cable. Weight, 33 lbs.

Model B-36W, same as B-36 but base has ball bearing hard rubber swivel casters.

Model BS-36 \$36.00
 Model BS-36W 40.50

FLOOR STANDS

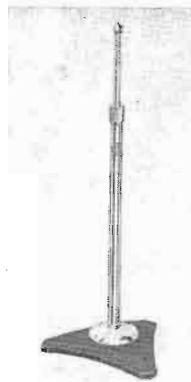

MS-25



MS-10C

Model MS-25

Weights 24 lbs. with heavy base 17" in diameter. Adjustable 37-66". Full chrome with gray base. $\frac{5}{8}$ "-27 thread. Non-slipping clutch.

Model MS-25 \$12.90

Model MS-10C

A good, low priced stand. Adjustable 35-64". Base diameter 10". Chrome finish with gray base. Weight 9 lbs. $\frac{5}{8}$ "-27 thread. Non-slipping clutch.

Model MS-10C \$5.85

MICROPHONE STANDS — ACCESSORIES



DeLuxe 360° Boom
(silent mobility)

A truly professional boom stand for either stationary or portable use. All controls noise-free and balanced for finger-tip action. Collapsible down to dimensions easily handled in automobile. Piston type air check prevents sudden collapse during adjustments. Upright securely locked in position with large brake shoe clutch assembly. Adjustable pneumatic orifice valve in base permits rapid height adjustment.

A 2-position, dual control microphone gunning device included for rotating microphone 360°. This functions at any boom extension. Base guide handle offers positive means of moving base on 4" ball bearing rubber casters.

SPECIFICATIONS

UPRIGHT: Retracted, 5¼'. Extended, 9'.

BOOM: Retracted, 7'. Extended, 18'.

BASE SPREAD: 42".

CONSTRUCTION: Tubular section aluminum. Castings of aluminum alloy. ⅝"-27 thread.

FINISH: Gun-metal gray.

WEIGHT: 56 lbs. including 22 lb. counter weight.

Model BS-37 Boom \$375.00

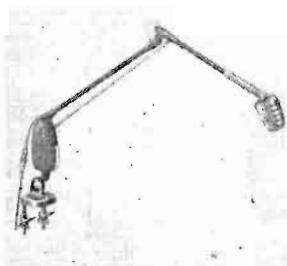

Dazor Stands

When a microphone is mounted on a Dazor floating arm, the flexibility and reach simplify microphone placement for the artist. Shown at the left is the very popular desk model, GRDZ-1, while below is the floor model GRDZ-2. Desk model has dual clamp while floor model has heavy cast 12" base. Distance from floor to arm hinge is 39".

Model GRDZ-1 \$19.40

Model GRDZ-2 30.40

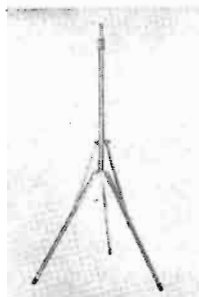

CS-1
Folding Stand

Popular for years in the Gates line. Folds up like a music stand. Height, 23-62". Weight, 5 lbs. ⅝"-27 thread. Finish: chrome tubing, cadmium base.

Model CS-1
\$9.60

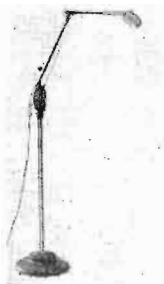

ORDERING DAZOR STANDS

The microphone of your choice is individually balanced to the Dazor stand. Give full information on microphone such as type number and where an RCA microphone, give "MI" number. If ordering microphone with stand, simply note that microphone will be used with Dazor stand. — Because of custom requirements delivery is usually about 30 days.

MICROPHONE CONNECTORS

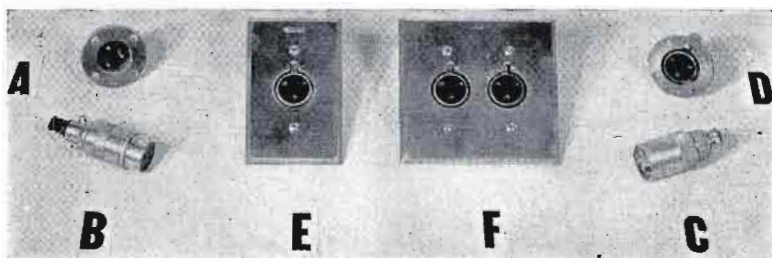

Cannon P Series

Probably the most used connector in Radio, TV, and Communications. Approximately 1 1/8" diameter. Figs. B and C, above, are about 2 1/4" long. Satin chrome finish. All types have latch locks.

Symbol	Cat. No.	Description	Price
A	P3-14	Receptacle for chassis mounting, male, 3 prong	\$ 1.68
B	P3-CG-115	Cable receptacle, female, 3 prong	3.78
C	P3-CG-125	Cable plug, male, 3 prong	3.09
D	P3-13	Receptacle for chassis mounting, female, 3 prong	3.21
E	P3-35	Wall plate with 3 prong female receptacle	5.49
F	P3-35-2G	Wall mounting with two 3 prong female receptacles	11.13

Cannon XL Series

A smaller Cannon connector with latch lock feature, 1 3/4" diameter. Finish, bright nickel.

Symbol	Cat. No.	Description	Price
G	XL3-14	Chassis receptacle, male, 3 prong	\$.72
H	XL3-11	Cable receptacle, female, 3 prong	.93
J	XL3-13	Chassis receptacle, female, 2 prong	.93
K	XL3-12	Cable plug, 3 prong, male	.90
L	XL3-35	Single, 3 prong, female, wall plate	2.64
—	XL3-35-2G	Double, 3 prong, female, wall plate	5.61

Amphenol Connectors

Cat. No.	Description	Price
75-MC1F	Straight plug, single and shield	\$.32
75-MC1FA	Angle plug, single and shield	.64
75-MC1M	Cable jack, single and shield	.21
75-MC1P	Phone plug adaptor, single and shield	.31
75-PC1M	Locknut receptacle, single and shield	.23
75-MC1S	Microphone receptacle with switch, single and shield	1.10
91-MC3F	3 prong cable receptacle, female	.65
91-MC3M	3 prong cable receptacle, male	.65
91-PC3F	3 prong chassis receptacle, female	.52

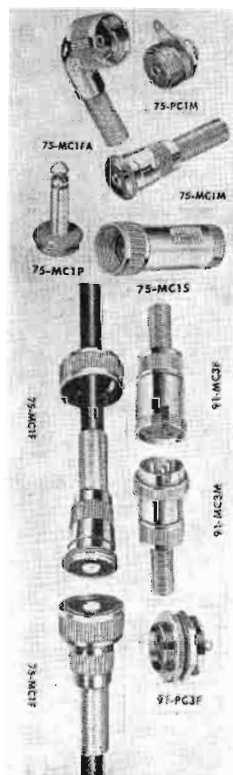

Microphone Cable

Complete listing of microphone cable will be found in this catalog. Please refer to Index for page number.

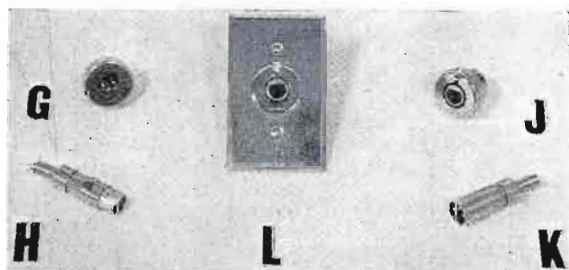

STUDIO ACCESSORIES



STUDIO WARNING LIGHTS

Conservative, attractive and necessary for good radio or TV operation. Letters silk-screened on plexiglass, transferring light rays edgewise, illuminating letters only. "On Air" light is incandescent for instant lighting while others are fluorescent. Metal portion steel with bronze finish. Size: 18"x3" wide by 6 1/2" high overall.

Cat.	Description	Price
AM-1	Studio A	\$14.95
AM-2	Studio B	14.95
AM-3	Control Room	14.95
AM-4	On Air	15.50
AM-5	Any special lettering ..	17.50



CALL LETTER PLATES

Available as listed to right. White letters on black background. Each plate individually cast to your call letters. Due to large variety of microphones, it is suggested that A-105 stand plate be used for those not listed. Delivery time about 60 days.

Cat.	Description	Fig.	Price
A-125	WE 618 mic.	E	\$ 9.85
A-118A	WE 633 mic.	B, D	11.50
A-110	Shure 556	—	13.25
A-105	Stand clip on*	C	5.95
A-115	RCA 77 mic.	A	11.00
A-118	RCA 88 mic.	F	11.50
A-127	WE 639 mic.	—	13.85
A-117	RCA 44 Series	A	11.00
A-116	RCA 74 Series	A	11.00

*State diameter of pipe.



Sessions Clock

Large legible white dial, black numerals. Large sweep second hand. Finish, gray. Size: 13 1/2" diameter. For 115 volts, 60 cycles.

Model RB-89 \$10.95
Plus Federal Tax



Seth Thomas Clock

Thin design, bright chrome finish, convex glass, dial and hands. Black numerals. Size: 15" diameter, 12 1/2" dial, 1 3/4" deep. For 115 volts, 60 cycles.

Cat. 602 \$16.95
Plus Federal Tax

Shielded Microphone Cable

Cat.	Description	Price	
		100' or less	100' or more
	Per Ft.	Per C	
8410	Single C, rubber jacketed.....	\$.10	\$ 7.90
MIC-100	Two C, rubber jacketed11	8.13
8428	Two C, rubber jacketed, heavy duty ..	.14	11.25
8423	Three C, rubber jacketed11	9.75
8411	Single C, plastic jacketed04 1/2	3.30
8422	Two C, plastic jacketed08	6.55

Transcription Players, Recorders, Receivers



Transcription Player
(Model 12V-5)

Four speeds: 16 $\frac{2}{3}$, 33 $\frac{1}{3}$, 45 and 78 RPM. Plays records to 16". Wrist action pickup with adjustable needle pressure. Dual cartridge. ± 2 db 30-15,000 cycles. 10 watt output. 12" speaker. Bass compensated volume control. Carrying case, gray DuPont fabricoid covering. Net carrying weight, 20 lbs.

Model 12V-5 Califone
Player \$122.50

TELETYPE

If you are teletype equipped, you have a direct line to the Gates factory or any Gates office. Teletype numbers are listed in the front of this catalog.

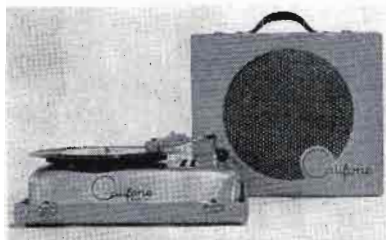

10P2-5 Califone

Three speeds: 33 $\frac{1}{3}$, 45 and 78 RPM. Uses GE reluctance pickup, separate treble and bass controls, extended range 12" speaker. Plays discs to 16". Wrist action pickup, 7 watt amplifier, ± 2 db 30-15,000 cycles. Type-writer style case, gray DuPont fabricoid covering. Carrying weight, 20 lbs.

Model 10P2-5 Player \$99.50



**Economy
Transcription Player**

Weights only 11 lbs; has 4 watt amplifier, plays discs to 16" at 33 $\frac{1}{3}$, 45 or 78 RPM. Dual cartridge, wrist action pickup, bass compensated volume control, 8" speaker.

Model 6U Player. \$69.95



3-Speed Tape Recorder

One of the few recorders that operates at 1 $\frac{1}{8}$ "/sec. This allows recording up to 6 hours on one 7" reel of 1800' tape. For lectures and long recordings of voice, this is ideal. Also records at 7 $\frac{1}{2}$ " and 15" sec. Has 3 $\frac{1}{2}$ watt amplifier, 6" speaker, 2 mic inputs, Hi-Z output as well as speaker and fast rewind. Size: 16 $\frac{1}{8}$ "x15"x9 $\frac{1}{8}$ ". Comes with microphone, reel of tape, take up reel and in rugged portable case. Made by Bell.

Model RT-75 Recorder..... \$164.95

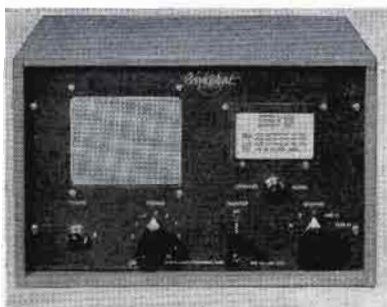

Conelrad Receivers

Available in cabinets and rack models. Has 5 preset radio station channels including 1240 and 640 Kc. Use preset channels to receive alert, then tune to 640 or 1240 for Civil Defense instructions. Alarm continuous until reset. Has fail-safe alarm circuit. Operates from wire antenna or low impedance line. Has 5" self-contained speaker.

TUBES: 6BE6, 6BA6, 6AV6, 12AT7, 6AQ5 and 543GT.

For 115 volts, 50/60 cycles.

117R900 Cabinet Model \$124.00
117R901 Rack Model (8 $\frac{3}{4}$ "x19") 124.00

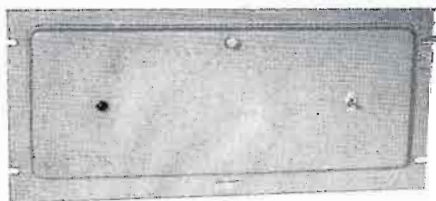

DC Power Supply

A selenium type full wave rectifier, well filtered to supply 6-12 volts DC at 6 amperes. Rating at 6 volts is continuous. At 12 volts, rating is 6 amperes ICCS or 3 amperes continuous. Rack panel 8 $\frac{3}{4}$ "x19" with drop-down front panel for internal servicing. Where DC on filaments or a good DC supply for relays is required, this model is of excellent commercial quality.

Model SA-102 Power Supply..... \$95.00

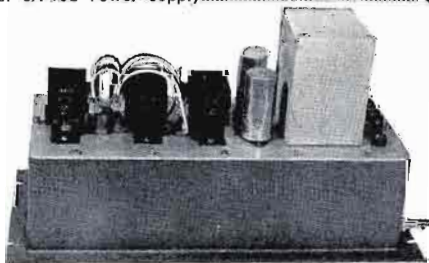

LOUDSPEAKERS

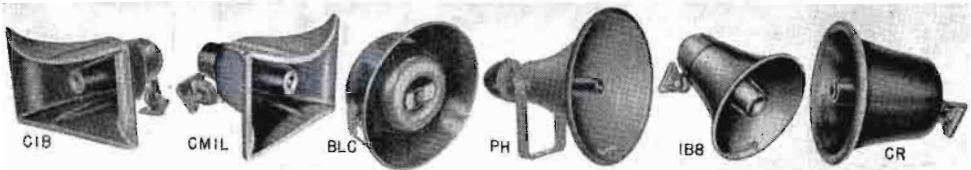

CIB Paging

Wide angle 12-watt sealed driver. 300-13,000 cps. 60°x120° dispersion pattern. Steel reinforced fiberglass construction. Voice coil 8 ohms. Size: 7½"x14"x12".

Model CIB-8...\$24.00

CMIL Paging

Same as above except smaller. Ideal in place of cone speakers for intercom and PA. 400-12,000 cps. 3 watts. Size: 6½"x9½"x8½". Voice coil 8 ohms.

Model CMIL-8 \$17.25

Weatherproof Coaxial

Has separate woofer and tweeter sections to provide 70-15,000 cps response in a 25-watt indoor or outdoor system. Voice coil 8 ohms. 22½" diam., 9" deep. For the best in PA, this is it.

Model BLC.....\$45.00

Reflex Trumpet

The popular PA speaker world-over. 150 cycle, low frequency cut-off. 85° sound distribution. Bell diam., 20¼". Air column length 3½ ft. Horn length 15¾". Comes complete with driver unit. Wt. 14 lbs.

Model PH.....\$18.60

Model IB-8

For paging and talk-back. Rating 12 watts, response 300-13,000 cycles. Dispersion 90°. Voice coil 8 ohms. Size: 8½" diam., 9 1/8" high.

Model IB-8.....\$19.50

Model CR

A reflex paging and talk-back speaker, handling 20 watts. Has good tonal balance for music. 250-6000 cycles response. Voice coil 16 ohms. 90° dispersion. Diam., 11½".

Model CR.....\$25.20

LEVEL CONTROLS

Desirable where several speakers on a common circuit and in different locations. L pad design. Pointer knob and escutcheon. Rating 15W.

ST-411 for 8 ohms.....\$2.82

ST-837 for 16 ohms.....2.82

ST-761 for 500 ohms.....3.72



Jensen PM Series

A fine quality, modest cost, permanent dynamic speaker in sizes 8" to 12". Voice coil impedances all types 6-8 ohms. Power rating 8" and 10" models is 8 watts. 12" model, 9 watts.

Model P8S, 8".....\$6.48
Model P10T 10".....6.30
Model P12T 12".....8.16



15" Coaxial

Here is a 16-watt, 15", two-way Jensen speaker with inbuilt frequency division network. Variable high frequency control supplied. Impedance 16 ohms.

Model K-310A
Speaker.....\$37.60

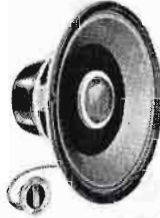

K-210 Coaxial

For low cost, two-way coaxial speaker, this Jensen 12" model has built-in frequency dividing system and a power rating of 13 watts. Impedance 8 ohms.

Model K-210
Speaker.....\$24.85



Deluxe Coaxial

This Jensen product is compression driver loaded by a 6-cell horn for highs above 2000 cycles. Low frequency unit is 15". Impedance 16 ohms. Power 25 watts. Includes variable frequency control.

Model H-520
Speaker.....\$79.00



Stromberg RF-460

A 12-watt, 8-inch speaker with 50-13,000 cps response. Impedance 8 ohms. Has 6.8 oz. Alnico V magnet. Resonant frequency 75 cps. Sound pressure level at distance 7½ ft. is 88 db. Has curvilinear cone.

Model RF-460.....\$20.00



Stromberg Dual

This dual speaker has a 12" low frequency unit with a 2" high frequency unit center by Carpinchoe leather. 30-14,000 cps response. Inbuilt crossover network. Rating 32 watts. Voice coil 8 ohms. Has 2.15 oz. Alnico magnet. The best for hi-fidelity.

Model RF-471.....\$59.95

LOUDSPEAKERS

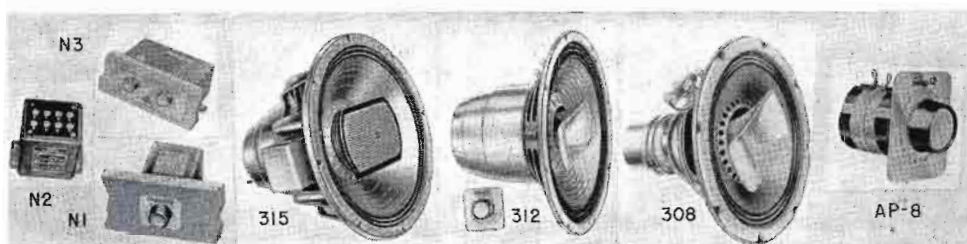

Triaxial 15"

Reproduces entire range from 30 cycles to inaudibility. Built around C15W woofer, mid-range via patented "Diffusicone" and highs with wide angle compression driven wide angle horn. Self-contained LC network crossing at 5000 cps. Includes control 15" cone, 8 ohm VC and handles 50 watts. The best, made by University.

Model 315\$132.00

Balance Control AP-8

For use with N2 networks to balance reproduction to room acoustics and personal taste. Supplied with knob and escutcheon.

Model AP-8\$3.75

Triaxial 12"

Full response from 40 cycles to inaudibility. This University speaker employs woofer, Diffusicone mid-range, HF-206 super tweeter and inbuilt crossover network and variable control. 8 ohm VC, 12" cone, handles 25 watts.

Model 312\$57.60

N-3 Crossover Network

Complete with built-in continuously variable "presence" and "brilliance" controls. For 8 ohm 3-way systems using 350 and 5000 cps crossovers. Adjustable mounting arrangements.

\$24.00

Triaxial 8"

A wonderful 8" three-way speaker that handles 25 watts and has 50-15,000 cps response. Woofer combined with Diffusicone mid-range and high frequency tweeter, compression driven. Includes crossover network. Voice coil 8 ohms. Made by University.

Model 308\$36.00

N-1 Hi-Pass Filter

Built-in continuously variable high frequency control. Matches 16 ohms to 1250, 2500, 5000 cycle crossover; 8 ohms to 2500, 5000, 10,000 cycles; 4 ohms to 5000 and 10,000 cycles.

\$9.00

Adjustable Speaker Networks

As 2-way network:

MODEL N-2A

Impedance	Crossover Selections
8 ohms	350, 700
16 ohms	350, 700
4 ohms	700

\$18.00

MODEL N-2B

Impedance	Crossover Selections
8 ohms	1250, 2500, 5000
16 ohms	2500, 5000
4 ohms	2500

\$12.00



15" Woofer

For the specific reproduction of low frequencies. Two spiders for positive piston action. Six lb. Alnico 5 magnet. Die-cast gilder construction. Adjustable voice coil permits match to 4-8 ohms and 10-16 ohms. For 50 watt systems.

Model C15W.....\$75.00

12" Woofer

Contains exclusive built-in facilities for limiting high end response to 700, 2000 or 5000 cycles, thus suiting crossover requirements of most tweeters. 8 ohms impedance, 30 watts power capacity.

Model C12W.....\$33.00

8" Woofer

Ideal for assembling a compact, limited space, high quality system—perfect too, as mid-range unit in low cost three-way system. Can also be used in multiples as expanding woofer. 8 ohms impedance. 25 watts power capacity.

Model C8W.....\$13.50

HF-206 Tweeter

High frequency response for beyond audibility. Super-efficient high output driver and horn assembly using "reciprocating flares" principle. Suitable for crossover 3580 cycles or above. Dispersion 120°x60°. 8 ohms impedance.

Model HF-206...\$27.00

Wide Angle Tweeter

Uses "reciprocating flares" wide angle horn and bonafide compression driver. Exceptional performance at modest cost. 8 ohms impedance, suitable for crossover down to 2000 cps.

Model 4401\$15.00

Dual Tweeter

Versatile high frequency tweeter. Driver can be connected for use in 4-8 and 10-16 ohm systems. Dispersion pattern variable with interconnection of drivers. High power capacity. For 2000 cycle crossover or above.

Model 4402\$24.00

When Ordering Loudspeakers

Most loudspeakers are supplied at voice coil impedance, such as 4, 8 or 15 ohms. Where used with higher impedance circuits such as 500 ohms, be sure and order proper matching transformers. — Also many cabinets are available in Blonde or Mahogany. Be sure to state finish desired.

GATES

173

Loudspeaker Cabinets --- Matching Transformers

Wall Baffles

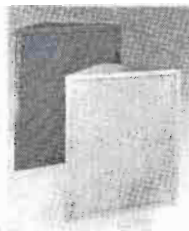

Illustrated to right. For 12" speaker. May be mounted on wall as shown or slight edge around front allows flush mounting. Finish mahogany.

Model DWB-12 \$7.65

Illustrated to left. C8A for 8" speakers. Size 12 1/4"x14"x6" deep. C12A for 12" speakers. Size 18"x20 1/4"x9" deep. A fine corner type speaker, mahogany finish with fabric covered baffle and woven plastic grill.

Model C8A Corner Baffle \$7.05

Model C12A Corner Baffle 9.75

NOTE: C8A and C12A available in blonde on special order.

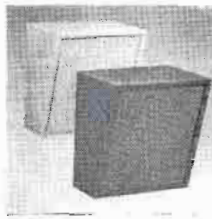

Bass Reflex Cabinets

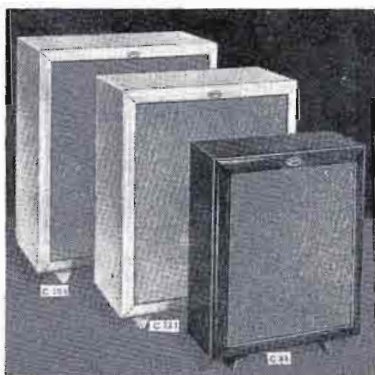

Delightfully modern cabinetry and with acoustically correct performance. Have concealed cutouts for speaker controls if used. Ideal for control room or fine studio-audition reproduction. Specify whether desired in mahogany or blonde.

Model C-151 (For 15" speaker)
Size: 32"x28"x15" deep \$46.35

Model C-121 (For 12" speaker)
Size: 29"x25"x13 1/2" deep 39.40

Model C-81 (For 8" speaker)
Size: 23 1/2"x20"x9" deep 28.75

Speaker Matching Transformers

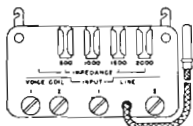

Made by Jensen but may be used with any loudspeaker for impedance matching. Primary adjustable to match 500, 1000, 1500 or 2000 ohms. Example: Four loudspeakers across a 500 ohm line would use the 2000 ohm primary, three would use 1500 ohm primary, etc.

Cat.	Rating	Price
ZY-2002	8 ohms, 10 watts	\$4.32
ZY-2003	8 ohms, 16 watts	6.18
ZY-4004	4 ohms, 10 watts	4.32

Wall Baffles

Built of selected veneers, strongly reinforced and hand finished. An excellent low cost baffle finished in mahogany. Air release on side. Has heavy woven fabric grill. — Ideal for general sound distribution of good quality.



WA8: for 8" speaker.
10 1/2"x11"x6 1/2" \$4.14

WA12: for 12" speaker.
15"x16 1/2"x8 1/2" 7.50

3-Way Speaker

Unique, highly efficient, hi-fidelity reproducer for monitoring and quality reproduction. Contains 3 speakers, 2 six-inch cone speakers and one tweeter. Includes cross-over network in special modified bass reflex enclosure to increase low frequency range. Cabinet of 3/4" birch veneer. Impedance 4 ohms. Size: 23 1/2" wide, 11 1/2" high, 12" deep. Finish in mahogany, with blonde available on special order.



DM-1M Speaker \$49.50

Labyrinth



This is the finest in loudspeaker cabinets. Has built-in acoustical labyrinth specially designed for 12" or 15" speakers such as RF-471 or K-310A. A beautiful cabinet available on special order either in blonde or mahogany. Size: 39 1/2" high, 24" wide, 20 1/2" deep.

RFCO—Blonde \$139.95

RFCM—Mahogany 139.95

Ceiling Baffle

Floating conical action. Spun aluminum, satin finish. Provides 360° coverage. Accommodates 8" standard cone speaker. Mounts flush with ceiling.



AL8-A Baffle \$7.29

RACK CABINETS DM-1X

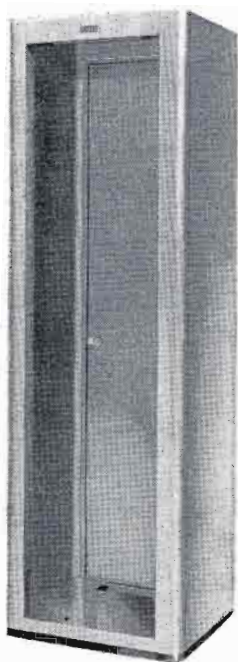

DM-1X Cabinet
complete
\$95.00

TRM-3 Joiner Trim
\$12.50

A well built, deluxe rack cabinet for all applications. Has solid sides, full size rear door with louvers at top and bottom, and large firm gripping back door handle. Manufactured from 18 gg. stretcher level cold rolled furniture steel, resistance welded. Illustration below shows how two or more DM-1X cabinets may be joined together by use of the TRM-3 trim strip. Finish is in medium gloss gray for both smart appearance and easy cleaning. Removable corner trims to cover mounting screws is standard equipment.

SPECIFICATIONS

HEIGHT OVERALL: 78".
 WIDTH OVERALL: 23 1/4".
 DEPTH OVERALL: 20".
 DOOR SWING: 20".
 PANEL SPACE: 19"x71 3/4".
 CLEARANCE BEHIND PANEL: 17".
 PANEL MOUNTING: Standard rack multiples
 12/24 mounting screws provided.
 DISTANCE FROM FRONT OF RACK PANEL TO
 FRONT OF CABINET (corner trim): 3/8".
 NET WEIGHT: 135 lbs.
 PACKED WEIGHT: 230 lbs.

NOTE: In quantity purchases this cabinet is available in other heights and colors and at prices proportionate to quantities purchased.

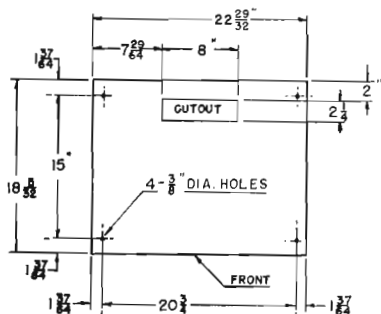

BASE DIMENSIONS, DM1X RACK



GATES

RACK CABINET RAK-1

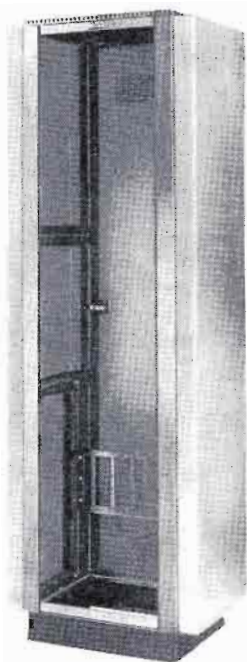

A unit system type of rack cabinet of open frame construction, having removable sides along with various shields, joiner trims and end bells. Similar to those found in RCA systems. Rack mounting strips are movable from front to back in 6 steps of $1\frac{1}{4}$ ". Basic frame includes 2 panel mounting angles, 2 terminal board mounting angles, full size rear door and panel mounting screws. Other accessories are as follows:

SINGLE CORNER TRIM TRM-1: Covers the rack mounting bolts on each corner. Two used for single cabinet or any number of cabinets.

DOUBLE CORNER TRIM TRM-2: Covers rack mounting bolts and joins two cabinets together. One used to join second cabinet to first, third to second, etc.

SIDE PANELS SP-1: Commonly known as end bell. Two used for single cabinet or any number of cabinets joined together.

LARGE SIDE SHIELD SH-1: An electrical shield plate $15\frac{1}{8}$ "x28" in size.

SMALL SIDE SHIELD SH-2: Same as SH-1 above only $15\frac{1}{8}$ "x21" in size.

TERMINAL BOARD MOUNTING BRACKET BRK-1: Mounts at bottom rear of cabinet for the support of audio and power terminal blocks.



SPECIFICATIONS:

- HEIGHT OVERALL: 84".
- WIDTH (less SP-1 side panel): 22".
- WIDTH OF SP-1 SIDE PANEL: 3".
- DEPTH OVERALL: 21".
- DOOR SWING: $22\frac{1}{2}$ ".
- PANEL SPACE: $19'$ x77".
- MAXIMUM CLEARANCE BEHIND FRONT PANEL: 17".
- PANEL MOUNTING: Standard rack multiples, 12/24 mtg. screws provided.
- FINISH: Medium gloss gray.
- NET WEIGHT RAK-1: 100 lbs.
- SHIPPING WEIGHT: 195 lbs.



Ventilating Fan

Used with RAK-1 cabinet. Mounts in top to withdraw hot air in case contents of cabinet requires more than convex ventilation. — Quiet operating suction fan, 115 volts, 50/60 cycles.

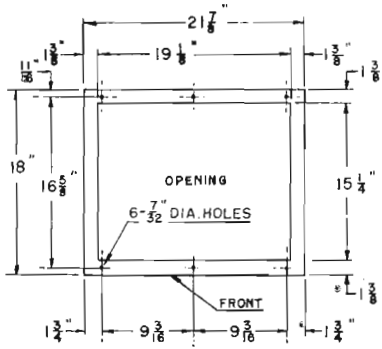

BASE DIMENSIONS, RAK-1 RACK

RAK-1 Basic Cabinet	\$120.00
TRM-1 Single Corner Trim	10.00
TRM-2 Double Corner Trim	11.00
SP-1 Side Panel	19.00
SH-1 Shield	5.50
SH-2 Shield	6.25
BRK-1 Terminal Board Mtg. Bracket ...	3.40
RAK-F-1 Ventilating Fan	39.50

NOTE: In quantity purchases this equipment available in other colors and proportionately lower prices where single purchase is in excess of 25 cabinets.

RACK CABINET RAK-2



A rugged, well built cabinet similar to that frequently found in the Western Electric type of installation. Manufactured of 16 gg. cold rolled stretcher level furniture steel, resistance welded and beautifully finished in medium gloss gray. — The RAK-2 cabinet has split rear doors with louver ventilation at both top and bottom. Also top of cabinet is perforated. The two inner sides have five horizontal brackets for cable supports. Side knockouts near the bottom are also provided on each side for wiring between cabinets, where more than one cabinet is employed.

SPECIFICATIONS

HEIGHT OVERALL 84".
 WIDTH OVERALL: 22".
 DEPTH OVERALL: 20 1/4".
 DOOR SWING: 9 1/2".
 PANEL SPACE: 19" x 77".
 INSIDE CLEARANCE
 BEHIND FRONT PANEL: 17".
 DISTANCE FROM FRONT OF
 PANEL TO FRONT OF CABINET: 7/16".
 PANEL MOUNTING: Standard rack multiples,
 12/24 screws provided.
 FINISH: Medium gloss gray.
 NET WEIGHT: 135 lbs.
 WEIGHT PACKED: 230 lbs.



RAK-2 Cabinet complete
 \$170.00

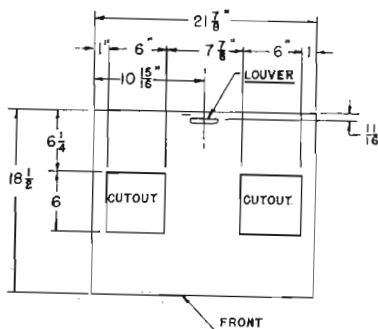

BASE DIMENSIONS, RAK2 RACK

NOTE

Available on quantity purchase in other colors and proportionately lower prices where quantity exceeds 25.

RACK CABINET RAK-6

One of the finest rack cabinets available today in the economy field. Made of 18 gg. cold rolled furniture steel, resistance welded. Has full length rear door, louver ventilated at top and bottom. Finish is medium dark gloss gray for both attractive appearance and easy cleaning.

SPECIFICATIONS

HEIGHT OVERALL: 78".
 WIDTH OVERALL: 23 1/4".
 DEPTH OVERALL: 19 1/4".
 DOOR SWING: 20 1/2".
 PANEL SPACE: 19" x 7 1/4".
 CLEARANCE BEHIND PANEL: 17".
 PANEL MOUNTING: Standard rack multiples,
 12/24 mounting screws provided.
 DISTANCE FROM FRONT OF
 PANEL TO FRONT OF CABINET: 1 1/16".
 NET WEIGHT: 125 lbs.
 WEIGHT PACKED: 220 lbs.

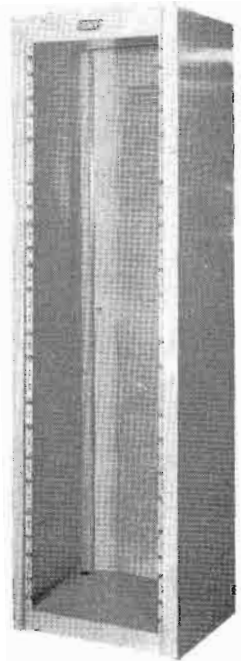

For Tape Recorders

Due to the fact that the majority of rack cabinets manufactured today do not permit extending the reels over the edge of the cabinet, Gates has made available the TRM-4 rack mounting inserts. Consists of a pair of full length adaptors that attach to the panel mounting strip to bring all rack panels flush with the front of the cabinet.



RAK-6 cabinet complete \$69.50
 TRM-4 (pair) inserts 9.90



← In the RAK-6 cabinet, Tinnerman speed nuts slip over the hole to be used for panel mounting. This provides self-alignment, retaining full strength. 60 are supplied with mounting screws.

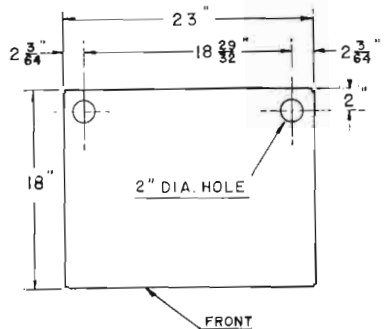

BASE DIMENSION, RAK6 RACK

RACK CABINETS AND ACCESSORIES



Waist High Cabinet

Designed to make full use of wall space by placing under windows or may be used adjacent to desk. Linoleum top over a 5-ply plywood base is available as an accessory and will serve as desk or table top.

CABINET: Heavy cold rolled furniture grade steel, resistance welded. Size: 37 $\frac{3}{4}$ " high x 23 $\frac{7}{8}$ " wide x 23" deep. Rack panel space: 19"x33 $\frac{1}{4}$ ". Back door is removable solid panel. Finish, gloss gray.

FOOT BASE: Accessory, fits under cabinet for styling and as mop board. Size: 23 $\frac{1}{4}$ "x19"x2 $\frac{1}{2}$ " high. Finish, black.

LINOLEUM TOPS: Accessory. Available in single, double and triple sizes for one cabinet or two and three cabinets joined together. Battleship dull black top on 5-ply plywood base, trimmed in chrome.

CR-70 waist-high cabinet	\$52.00
CR-71 base only	13.50
TR-80 single linoleum top	19.00
TR-81 double linoleum top	27.00
TR-82 triple linoleum top	39.00



Blank Panels (Steel)

Made of 1/8" steel flat stock, regular rack slotting, painted black ripple enamel.

Cat. No.	Size	Price
6600	19"x1 $\frac{3}{4}$ "	\$.69
6601	19"x3 $\frac{1}{2}$ "81
6602	19"x5 $\frac{1}{4}$ "	1.02
6603	19"x7"	1.20
6604	19"x8 $\frac{3}{4}$ "	1.44
6605	19"x10 $\frac{1}{2}$ "	1.68
6606	19"x12 $\frac{1}{4}$ "	1.98
6607	19"x14"	2.25
6608	19"x15 $\frac{3}{4}$ "	2.52
6609	19"x17 $\frac{1}{2}$ "	2.82
6610	19"x19 $\frac{1}{4}$ "	3.15
6611	19"x21"	3.48

Blank Panels (Aluminum)

Made of 3/16" half hard, flat aluminum stock, punched standard rack slots and finished in Gates gloss gray. Other finishes on special order. Vertical sizes stated below actually 1/32" less to allow for paint and fitting.

Cat. No.	Size	Price
15483-2	19"x1 $\frac{3}{4}$ "	\$1.05
15483-10	19"x3 $\frac{1}{2}$ "	2.10
15483-18	19"x5 $\frac{1}{4}$ "	3.15
15483-26	19"x7"	4.20
15483-34	19"x8 $\frac{3}{4}$ "	5.25
15483-42	19"x10 $\frac{1}{2}$ "	6.30
15483-50	19"x12 $\frac{1}{4}$ "	7.35
15483-58	19"x14"	8.40
15483-66	19"x15 $\frac{3}{4}$ "	9.45
15483-74	19"x17 $\frac{1}{2}$ "	10.50
15483-83	19"x19 $\frac{1}{4}$ "	11.55

NOTE: Deduct 10% where unfinished.

Important

Due to the rapidly varying industry-wide prices of both ferrous and non-ferrous metals, the prices shown for blank panels are subject to possible increases. Where the increases do not exceed 10% Gates will ship without requesting your authority unless otherwise stated when ordering.

PAR-METAL RACK CABINETS

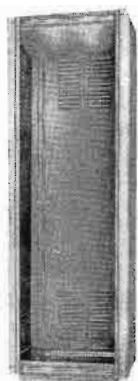

DeLuxe Par-Metal

A modern cabinet with smart styling. Removable corner trims cover rack mounting screws. Chrome strip at top and bottom add to attractiveness. Shipped knocked down. Panel angles are 7/64" steel drilled 10/32". Full size rear door. 22" wide, 18" deep. Height stated below. Finish, slate gray.

Cat. No.	Doors	Height	19" Rack Space	Inside Depth	Price
ER-223	Rear	43 1/4"	36 3/4"	16 3/4"	\$48.15
ER-225	Rear	67 3/4"	61 1/4"	16 3/4"	59.25
ER-227	Rear	83 1/2"	77"	16 3/4"	71.70
FD-223	Front and Rear	43 1/4"	36 3/4"	16"	57.90
FD-225	Front and Rear	67 3/4"	61 1/4"	16"	72.00
FD-227	Front and Rear	83 1/2"	77"	16"	90.00

Standard Par-Metal

A fine cabinet similar to deluxe model above but less corner trims. Vertical front corners are nicely rounded—bottom and top chrome style strip add to appearance. Panel angles 7/64" thick, tapped for 10/32" machine screws. Full size rear door. Width 22", depth 16 1/2", height shown below. Finish, slate gray. Shipped knocked down.

Cat. No.	Doors	Height	19" Rack Space	Inside Depth	Price
ER-213	Rear	42"	36 3/4"	15 1/4"	\$34.35
ER-215	Rear	66 1/2"	61 1/4"	15 1/4"	50.85
ER-217	Rear	82 1/4"	77"	15 1/4"	61.20
FD-215	Front and Rear	66 1/2"	61 1/4"	13 1/2"	67.20
FD-217	Front and Rear	82 1/4"	77"	13 1/2"	81.90



Desk Cabinet

A fine desk cabinet for standard 19" rack panels with top hinged door and catch. Back opening for cable entrance, etc. Tapped 10/32" machine screw. Width 21 1/2", depth 15". Height stated below. Finish, black ripple enamel.

Cat. No.	Height	19" Panel Space	Price
DL-128	10 1/2"	8 3/4"	\$12.90
DL-1210	12 1/4"	10 1/2"	14.58
DL-1225	14"	12 1/4"	15.69
DL-1413	15 3/4"	14"	17.28

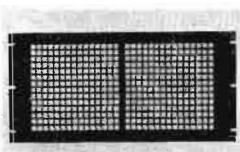

Grille Panel

Made of 1/8" steel, 19" wide. Finish, black. Stamped grille provides about 60% opening.

Cat. No.	Size	Price
P-661	5 1/4"	\$2.79
P-662	7"	3.06
P-663	8 3/4"	3.66
P-665	10 1/2"	4.05
P-667	12 1/4"	4.11

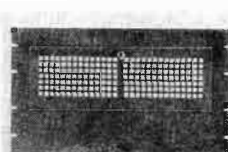

Grille Door Panel

Standard 19" rack panel, 1/8" steel. Finish, black, with hinged flush drop-down door.

Cat. No.	Size	Price
P-680	8 3/4"	\$5.70
P-681	10 1/2"	6.15
P-682	12 1/4"	6.75

FOUR STOCK CARRYING LOCATIONS:

ATLANTA — 1133 Spring St., N. W.

HOUSTON — 2700 Polk Ave.

LOS ANGELES — 7501 Sunset Blvd.

QUINCY, ILL. — 123 Hampshire St.

CAST ALUMINUM RACK HOUSINGS



Above, the SA rack mount housing front view with drop-down door closed. Entire construction is of cast aluminum.

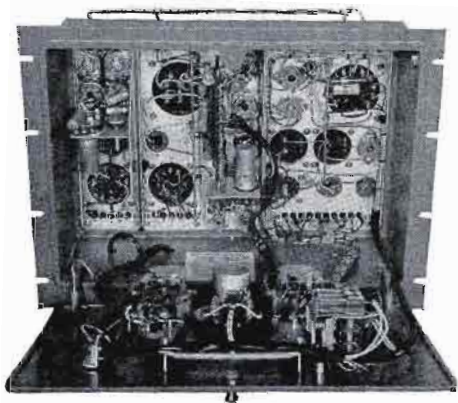

To service equipment mounted on SA housings, drop down the rigid cast front door. Note how every under-chassis component can be reached. Cabinet style strips need not be removed to drop down front door.

An exclusive Gates design with wide application in both audio and radio frequency construction. Use of aluminum throughout offers particular advantages at audio frequencies in reducing noise by reason of reduction in varied ground potentials. — The heavy wall construction is also a natural ground bond where used with RF circuits. When front drop-down door is closed, this housing offers complete inner housing shielding far greater than afforded in thin sheet aluminum, as side walls are 5/8" thick. Illustration below shows one way in which equipment is attached in the back. This places all inner wiring to front of rack for ease in maintenance. Five available sizes shown in sketch at bottom of page. Finish, medium gray Pebbletex.

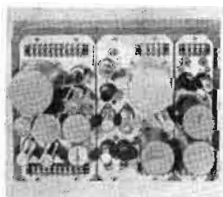

SA-400 Housing	\$30.00
SA-500 Housing	30.50
SA-600 Housing	31.50
SA-700 Housing	32.50
SA-800 Housing	33.50

SPECIAL PRICES: Where purchased in quantities of 50 or more of one size, write for quantity prices. Special finishes also available in quantity.

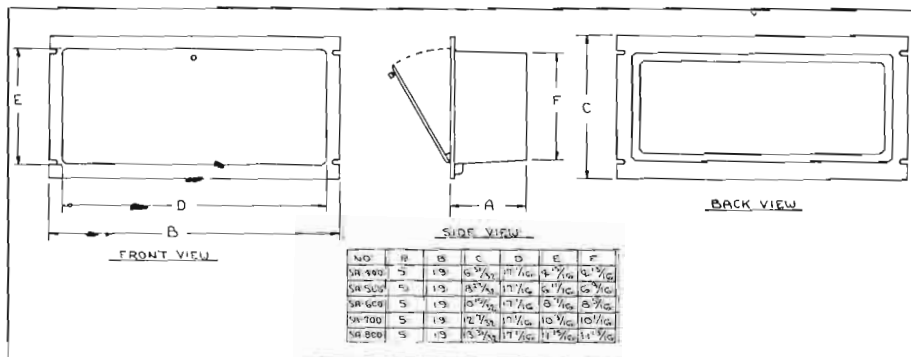

DYNAMOTE PORTABLE REMOTE AMPLIFIER



"Dynamote" has been symbolic of remote amplifying equipment for nearly a quarter century. The name originated back when the dynamic microphone was first introduced. Today's "Dynamote" is indeed modern. — Weighs only 22 pounds, measuring $5\frac{7}{8}$ " high, $10\frac{1}{4}$ " wide and $17\frac{3}{4}$ " deep with battery compartment attached. Hinged illuminated 4" VU meter, which folds in when not used, swings to exact eye level for broadcasting.

Four mixing channels handle four or less low impedance microphones of any type. After normal mixer loss there still remains a full 90 db of gain to handle any type of pickup including artists unusual distances from the microphone. — Printed wiring, not to be confused with printed circuit, adds greatly to reliability, smaller size, and has the happy result of faster manufacturing with the savings passed on to the purchaser. — Battery standby, with automatic changeover in case of power failure, is an optional accessory. Nothing has been spared in making the Dynamote the finest multi-channel remote equipment available today.

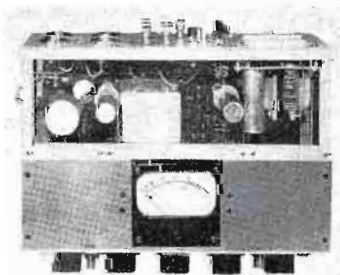

Looking down on the Dynamote when removed from the case. Entire unit is constructed in rigid, light-weight frame. In this way the carrying case does not become part of the mechanical design.

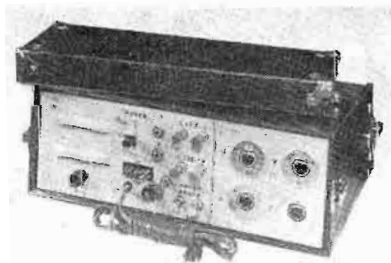

Back of the Dynamote handles all connections, microphones and even holds the Off-On switch. Receptacle in center is for accommodating the optional M-4933 battery unit.

Dynamote Specifications --- Ordering Data

The Dynamote is constructed around a small, light-weight, welded frame to which attaches the amplifier, power supply, front panel with controls and meter, and the back panels for connectors and terminations. This slips into a rugged carrying case made of durable bass wood, covered with a heavy grade of black leatherette. A large leather handle, and hardware in nickel, add the finishing touch.

Amplifier design has four audio stages and 15 db of feedback is employed. A full output of plus 22 dbm at 1% distortion is obtained. A 4 db output isolation pad provides a final maximum output of plus 18 dbm at no more than 1% distortion, or a 10 db range above the maximum permissible level of plus 8 dbm into a telephone line. — Mixing controls are Daven, ladder type, 20 steps of 2 db. Input is either 50 or 150 ohms.

When batteries are employed for standby, the M-4933 Continumatic adapter is purchased plus the M-4983 kit of batteries. The M-4933 adapter includes relay, metal-hinged battery compartment, cable and plug, all of which fit in the removable rear case compartment. Changeover to batteries is automatic when AC fails. Reverse is true when AC is restored.



The Dynamote is cataloged with the microphone connector plate but less microphone plugs. The entire plate of 4 connectors plugs into the amplifier chassis. No wiring is required on receipt of the equipment.

SPECIFICATIONS

OVERALL GAIN: 90 db \pm 3 db from microphone input to line output.
 FREQUENCY RESPONSE: \pm 1.5 db 30-15,000 cycles.
 DISTORTION: 1% or less 50-15,000 cycles at +18 dbm output.
 NOISE REDUCTION: 60 db below +8 dbm at -50 dbm input.
 MIXING CHANNELS: Four at 50/150 ohms.*
 POWER SUPPLY: Full wave transformer type with AC isolated.
 METER: 4" VU Scale B illuminated, adjusted 0 VU indication at +8 dbm.
 OUTPUT: 150/600 ohms. Output selected by switch to choice of 2 lines.
 OUTPUT JACKS: Front jack across line amplifier output.
 Rear jack No. 1 across line being used.
 Rear jack No. 2 order phone across line not being used
 and parallels order phone terminals.
 POWER: 115 volts, 50/60 cycles, 40 watts.
 WEIGHT: 22 lbs. less batteries, 29 lbs. with batteries.
 BATTERIES (if used): 2 type FP4, A batteries.
 5 type XX30, B batteries.

* 150 ohm input recommended for 200 or 250 ohm microphones.

ORDERING INFORMATION

M-4880A Dynamote with tubes, Cannon XL receptacles and carrying case	\$303.95
M-4880B Dynamote with tubes, Cannon P receptacles and carrying case	313.30
M-4933 Continumatic battery compartment with relay and plug, less batteries	22.00
M-4983 100% set of batteries	8.85
TK-183 100% spare tube complement	7.20
XL3-12 Microphone plug for XL receptacles, each90
P3CG12S Microphone plug for P receptacles, each	3.09



Left: Rear view with M-4933 battery compartment placed on top.

Center: M-4933 battery compartment with M-4983 battery kit.

Right: Under view of Dynamote showing clean assembly by printed wiring.

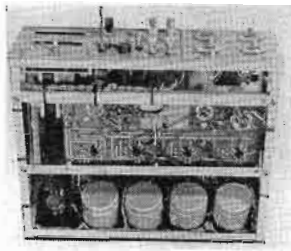

"BIAMOTE" --- Two Channel Remote Amplifier

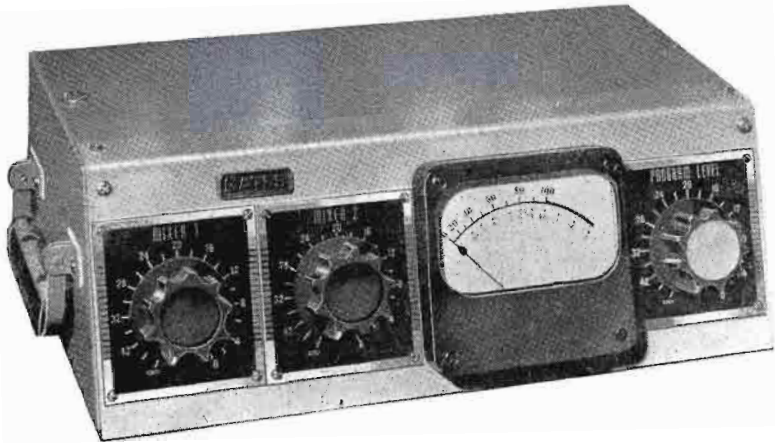

Remote pickups for either radio or TV probably call for more 2-microphone installations than any other combination. The "Biamote" fills this requirement with fine performance, light weight, rugged design, and a full complement of equipment including a 4" illuminated VU meter.

Constructed in a rugged, light-weight steel cabinet finished in gloss gray with dial plates in etched aluminum. Total weight is only 15 1/4 lbs. ready to use. Top removes quickly and is held in place with two snap-on fasteners. Front panel slopes at approximately 12 degrees and height is only 5 inches, permitting unobstructed view of any broadcasting event. —

The full size 4" illuminated VU meter is retained. "Biamote" design is functionally correct with the dual ladder type mixers to the left of the VU meter and the master gain control to the right of the meter.

All terminations are to the rear, including Off-On switch, line connections, headphone jack, microphone receptacles and power cord. Cannon type XL receptacles are standard, but larger knock-outs are provided for such connectors as the Cannon P series. These may be installed in a few minutes, where desired. — A full size hinged handle is provided on one side of the amplifier case.

SPECIFICATIONS

NUMBER OF MIXING CHANNELS: Two.
 INPUT IMPEDANCE: 50/150 ohms.*
 DISTORTION: 1% or less 50-15,000 cycles +18 dbm output.
 RESPONSE: ± 2 db 30-15,000 cycles.
 GAIN: 90 db ± 3 db from microphone input to line terminals.

NOISE: 60 db below +8 dbm at -50 dbm input, equivalent to -110 dbm measured with mixer wide open and master gain adjusted.

OUTPUT IMPEDANCE: 500/600 ohms.
 POWER: 115 volts, 50/60 cycles, 40 watts.
 WEIGHT: 15 1/4 lbs.
 SIZE: 14" wide, 8 1/2" deep, 5" high.

* 150 ohm input recommended for 200/250 ohm microphones.

ORDERING INFORMATION

M-5136 "Biamote" with tubes, less male microphone connectors	\$189.50
XL3-12 Male microphone connector, each90
TK-183 100% spare tube complement	7.20

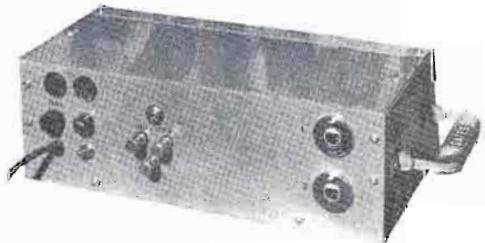
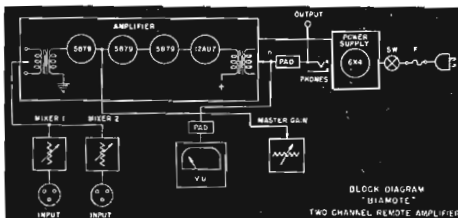

Single Channel---Presidential Remote Amplifiers

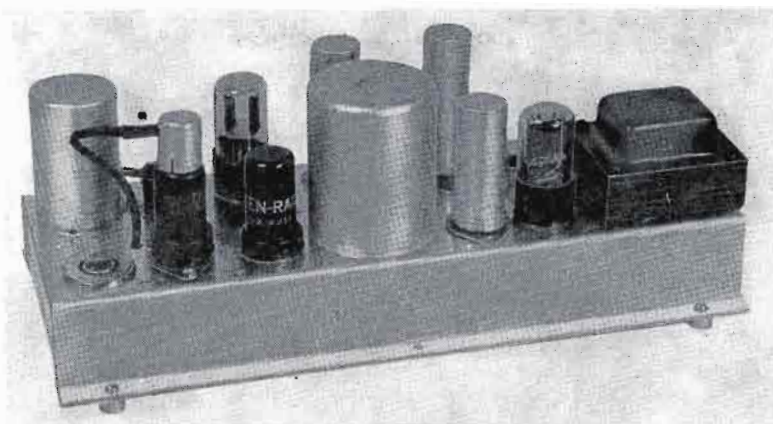

Model SA-134

Broadcasting's most used single channel remote amplifier. Thousands in daily use. Also widely used as a turntable preamplifier. — Completely self-contained with power supply. Constructed on aluminum chassis to assure maximum noise reduction. Includes Cannon XL input connector, locking type gain control, fuse and headset jack. Audio transformers of well shielded and balanced type for hum elimination either internal or from external inductive sources such as turntable motor. May be mounted on desk, in base of turntable cabinet or size allows mounting on 7"x19" rack panel.

Specifications

GAIN: 82 db ± 2 db.
DISTORTION: 1% or less +14 dbm output
50-15,000 cycles.
RESPONSE: $\pm 1\frac{1}{2}$ db 30-15,000 cycles.
NOISE: 60 db or better below +8 dbm output
with signal input of -60 dbm.
IMPEDANCES: Input, 50/250 ohms..
Output, 500/600 ohms.
POWER: 115 volts, 50/60 cycles, 20 watts.
TUBES: 6J7, 6SJ7, 6SN7, 6X5.
SIZE: 17 $\frac{1}{4}$ " wide, 5 $\frac{1}{2}$ " high, 5 $\frac{1}{4}$ " deep.
SA-134 Amplifier with tubes\$78.00
M-3961 100% spare tube kit 3.68

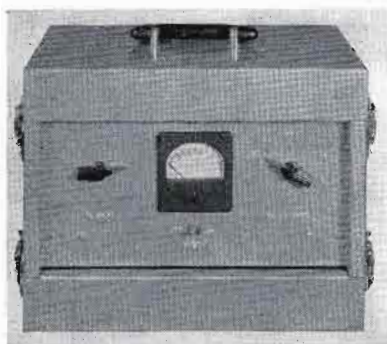

Presidential Amplifier

This design approved by major networks as a Presidential Amplifier. Used in joint feeding of several circuits such as combined networks, thus releasing the large banks of microphones in front of one individual. May be used for radio, TV and motion picture sound circuits. Battery operated. Constructed in rugged one - piece case with batteries in

bottom of case (see illustration to right). Meters indicate filament and plate voltage plus tube emission. — The Presidential Amplifier is a low gain distribution amplifier and not to be confused with a high gain remote amplifier. — Full detail and price will be supplied on request.

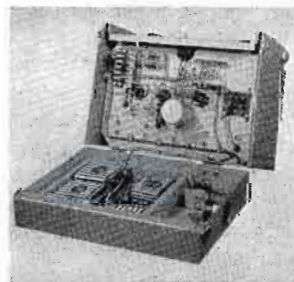

100% Transistor Single Channel Remote



M-5311 Transmote with case



The "Transmote"

In the wonderful world of transistors, Gates engineers have spent months in checking numerous circuits, components and many types of transistors. Believing that transistor performance should approach tube performance in all respects, final designs were not accepted until this result was obtained.

The "Transmote" does have low noise. Rated 55 to 60 db below +14 dbm output with a -60 dbm input. "Transmote" features include non-microphonic battery operation, very small size, weighs only 3 lbs. with batteries, and a set of batteries averages 80 hours or about 8c per hour.

Five transistors are used in 4 temperature stabilized stages, the output stage being push-pull. Level control, headset jacks, microphone receptacle, gain control and output binding posts are all properly located for both portable or stationary service. Amplifier turns on when phones are inserted in jack. A wood jack plug is provided where phones are not used. Either way, it is impossible to close the carrying case without removing the phone plug and turning off the amplifier voltage.

Leather carrying case has adjustable shoulder strap that is removable. Case will fit suit coat or overcoat pocket. Many combinations are offered and listed on the next page. Here is compact, top-performing equipment, with all the desirable features of transistors, that opens a new era in quality audio equipment.

M-5311A Transmote less case

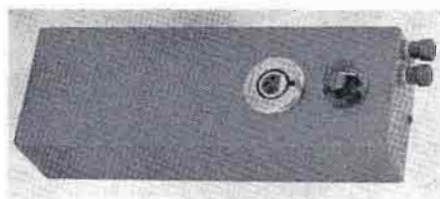

Transmote Specifications --- Order Combinations

SPECIFICATIONS

SIZE: (in carrying case) 9½" long, 3½" wide, 2½" deep.
 (less carrying case) 8½" long, 3" wide, 1⅞" deep.
WEIGHT: 3 lbs. net with case.
GAIN: 78 db ± 2 db.
DISTORTION: 2% or less 70-10,000 cycles.
NOISE: 55 to 60 db below +14 dbm measured -60 dbm input.
INPUT: 150/250 ohms. May be used with 30/50 ohm microphone with 6 db less gain.
OUTPUT: 600 ohms. 4 db isolation pad in output.
POWER: Three 8 volt mercury batteries in kit M-5339.
BATTERY LIFE: Approximately 80 hours.

ORDERING COMBINATIONS

M-5311 Transmote with carrying case, one set batteries	\$145.00
M-5311A Transmote less carrying case, with batteries	136.75
M-5339 Complete spare battery kit*	9.95
XL3-12 Mating microphone connector90

* Wired, in container, ready to insert.

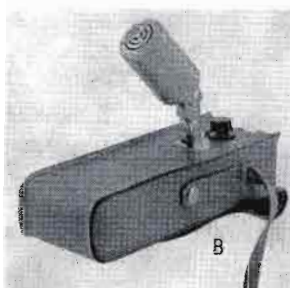
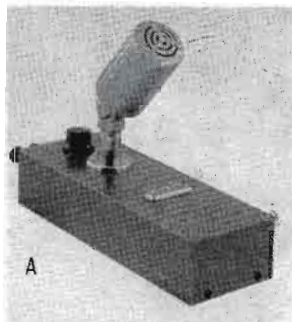

Remote Set M-5344 (above)

Illustrations above show the many possible combinations from this complete package. Fig. A is Transmote used as desk stand. Fig. B, Transmote in case used as sports microphone. Fig. C is Transmote with four-foot extension cable for interviews, etc. Supplied in this kit are: (a) Transmote, (b) Altec 660B microphone, (c) 4' extension cable, and (d) carrying case. Headphones are illustrative only.

M-5344 Remote Package \$202.75

Remote Set M-5345 (below)

This set differs from set M-5344 in the type of microphone. Here the slim Electro-Voice 648 microphone especially equipped with swivel is provided. Includes: (a) Transmote, (b) M-5322 microphone assembly, (c) 4' extension cord set, and (d) carrying case. Headphones are illustrative only.

M-5345 Remote Package \$194.00

Microphones described Pages 162-164.



Two Channel Transistor Remote Amplifier



The "Twinsistor"

Two microphone channels, VU meter, generous gain, low current battery operation and total weight with carrying case only 7 pounds. Size of unit: 7½" wide, 7" deep and 3⅝" high. — The Gates "Twinsistor" is indeed the smallest, lightest weight multi-channel amplifier built yet.

Performance is top flight. Noise is comparable to good tube design. Response exceeds and distortion is far less than most grade A telephones lines. A plastic carrying bag of the camera type is 10½" wide, 8" high, 3½" deep. Has adjustable shoulder strap. Bag

will hold amplifier, headphones and one average microphone with cable. — Six transistors comprise a 4-stage temperature stabilized amplifier with push-pull output. Amplifier holds two battery kits. Changeover switch is on rear of case. Microphone receptacles are Cannon XL. Meter is standard 3" VU with fixed pad for +8 VU output at zero scale. — Master gain is not required in transistor design and attenuators may be operated at any setting without overload or noise increase. Amplifier turns on when headphones are inserted in jack. — Specifications next page.

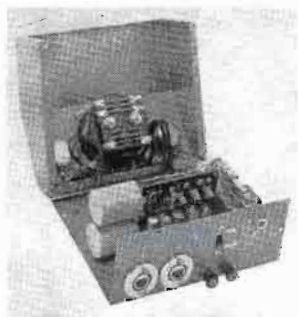

←
To change batteries, flip up. If service is ever needed, every part is exposed.

→
Small "Twinsistor" size allows plugging in microphone without need of desk stand.

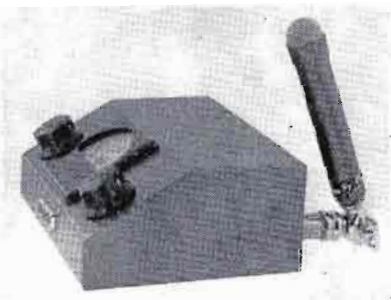

"TWINSIStOR" --- TUBELESS TUBE

"TWINSIStOR" SPECIFICATIONS

SIZE: (amplifier) 7½" wide, 7" deep, 3⅛" high, (case) 10½" wide, 8" high, 3½" deep.
WEIGHT: (in case) 7 lbs., (less case) 5½ lbs.
GAIN: 78 db ±2 db from mic input to line output.
RESPONSE: ±2 db 70-15,000 cycles.
DISTORTION: 2% or less 70-10,000 cycles at +14 dbm.
NOISE: 55 to 60 db below +14 dbm measured at -60 dbm input.
MIXING CHANNELS: Two at high level (transistor preamplifier for each stage).
IMPEDANCES: (input) 150/250 ohms, 30/50 ohms with 6 db less gain.
(output) 600 ohms, 4 db isolation pad in output.
BATTERIES: Three 8 volt mercury in kit M-5339. Provision for 2 sets with switch changeover.
BATTERY LIFE: Approximately 80 hours per set.

ORDERING INFORMATION

M-5168 "Twinsistor" complete with carrying case and one set of batteries	\$199.50
XL3-12 Male microphone connector (2 required), each90
M-5339 Battery kit in container and wired	9.95
M-5332 Microphone with swivel to plug in back of "Twinsistor" illustrated Page 188*	44.65

* Microphone Electro-Voice 648 described Page 164.

THE TUBELESS TUBE

This small transistor amplifier has particular adaptation in raising the gain of a microphone circuit. Often in TV production, or longer than normal lines, it is desirable to raise the potential gain of a microphone circuit. Designed to connect at any place into the microphone cable such as on a boom stand; or, as non-microphonic, may even lay on the floor.



Built into an aluminum tube 2½" in diameter and 4½" long. Cannon XL receptacles are on each end. As the battery drain is extremely low, the tubeless tube may be turned on and left on for over a year before changing batteries. Batteries are self-contained. Set screw in case functions as On-Off switch, used only when storing. Design is a single stage transistor, temperature stabilized. Finish is in dull non-gloss green.

SPECIFICATIONS

GAIN: 15 db ± 1 db.
FREQUENCY RESPONSE: ±3 db 70-15,000 cycles.
INPUT IMPEDANCE: 150/250 ohms.
OUTPUT IMPEDANCE: 50/150 ohms.
CONNECTORS: Cannon XL3-13 input. Cannon XL3-14 output.

ORDERING INFORMATION

M-5312 Tubeless tube with batteries	\$37.50
XL3-12 Mating input connector90
XL3-11 Mating output connector93
M-5350 Battery kit	2.25

CRYSTALS AND OVENS

Broadcast Crystal and Oven



Used in all Gates broadcast transmitters. Available with or without thermometer. Fully FCC approved. Frequency range, 400-1750 Kc as ordered. Normal temperature 60° C. Uses standard 5-pin socket. Air gap adjustment under top name plate. Accuracy in proper design oscillator better than ± 5 cycles.

JK57M crystal and oven,
less thermometer \$50.00
JK57MT crystal and oven,
with thermometer 55.00



JK02 Oven

Used in most Gates high frequency transmitters where 0.005%, or better accuracy is desired. Holds one or two H17 crystals in holders to provide accurate temperature control. Oven temperature 75° C. $\pm 5^\circ$. Fits in octal base. Has 6.3 volt heater. — Listed less crystal. For crystal, order H17.

JK02 Oven \$12.50

JK03 Oven

Similar to JK02 but holds one H17 crystal and holder and fits 5-pin standard socket. This unit carries Military No. HC-6(U), used in HF5, HF10 and HF20 transmitters.

JK03 Oven \$12.50



JK Frequency Standard

The JK Secondary Frequency Standard has been proved by Broadcast, Police, Marine, Air Control Stations as well as Industrial Plants, servicemen, and many others. Two hermetically sealed "Stabilized" crystals are used for frequency control (1000 Kc and 100 Kc) which provide dependable, drift free, fundamental frequencies. Output in 1 Mc steps to 500 Mc and 100 Kc and 10 Kc steps to 40 Mc.

Dimensions: 12"x8"x8". Power supply: 115 volts AC, 60 cycles. Complete with tubes and JK "Stabilized" crystals.

FS-344 Frequency Standard \$ 79.50
FS-344A Temperature Controlled
Frequency Standard 129.50

JK07E Broadcast Oven

This crystal and oven used in all Gates FM and TV transmitters. A precision oven with sealed-in glass thermostat. Fully FCC approved. Normal operating temperature 50° C. Will hold temperature as much as 75° C. above the ambient. Listed less crystal, as various frequencies and tolerances vary in price, which will gladly be quoted on request.

JK07E Oven only \$49.50



G12A Broadcast Crystal

Fully FCC approved crystal of vacuum sealed type that does not require a temperature oven. Frequency range 540-1600 Kc. Stability ± 15 cycles, 0-50° C. Prices vary from \$69.50 to \$150.00 depending on specific use conditions. Send full details, and price will gladly be quoted.



Crystals and Holders

Model H17



Usually used with JK02 or JK03 ovens. In this manner, 0.005% or better accuracy obtained. Also used with all Gates HF transmitters for 0.005%. Available in frequencies 1 Mc to 50 Mc. Hermetically sealed holder.

Model H17 H17 Crystal and holder \$14.95

Model H7

Used in all Gates transmitters where 0.02% accuracy is sufficient. Comes in FT243 holder with pressure mounting stainless steel electrodes. Available 2-16 Mc. Fits octal socket pin spacing of .486".

H7 Crystal and holder \$14.95

Model H4

Similar to the H7 above only pin spacing is $\frac{3}{4}$ ". Range 1.8 Mc to 16 Mc. Pressure mounting with stainless steel electrodes. Neoprene gasket sealed.

HF4 Crystal and holder \$14.95

Model H12

Especially recommended for application between 350 Kc and 1800 Kc. Has pressure or fixed gap mounting. Stainless steel electrodes. Military type DC11. This model for special low frequency applications. Use JK57M for FCC approved broadcast service.

H12 Crystal and holder \$14.95

Model H8

Same characteristics as H7 only pin spacing is $\frac{1}{2}$ ". For replacement purposes only. Range 3-16 Mc.

H8 Crystal and holder \$14.95

Model H10

Similar to H7 only has pin spacing of .875" and for replacement purposes only. Frequency range 1.8 Mc to 10 Mc.

H10 Crystal and holder \$14.95

ORDERING CRYSTALS

Be sure to state frequency desired, when ordering. Model JK02 temperature controlled oven will hold 1 or 2 type H17 crystals and holders. All other types accommodate one crystal.

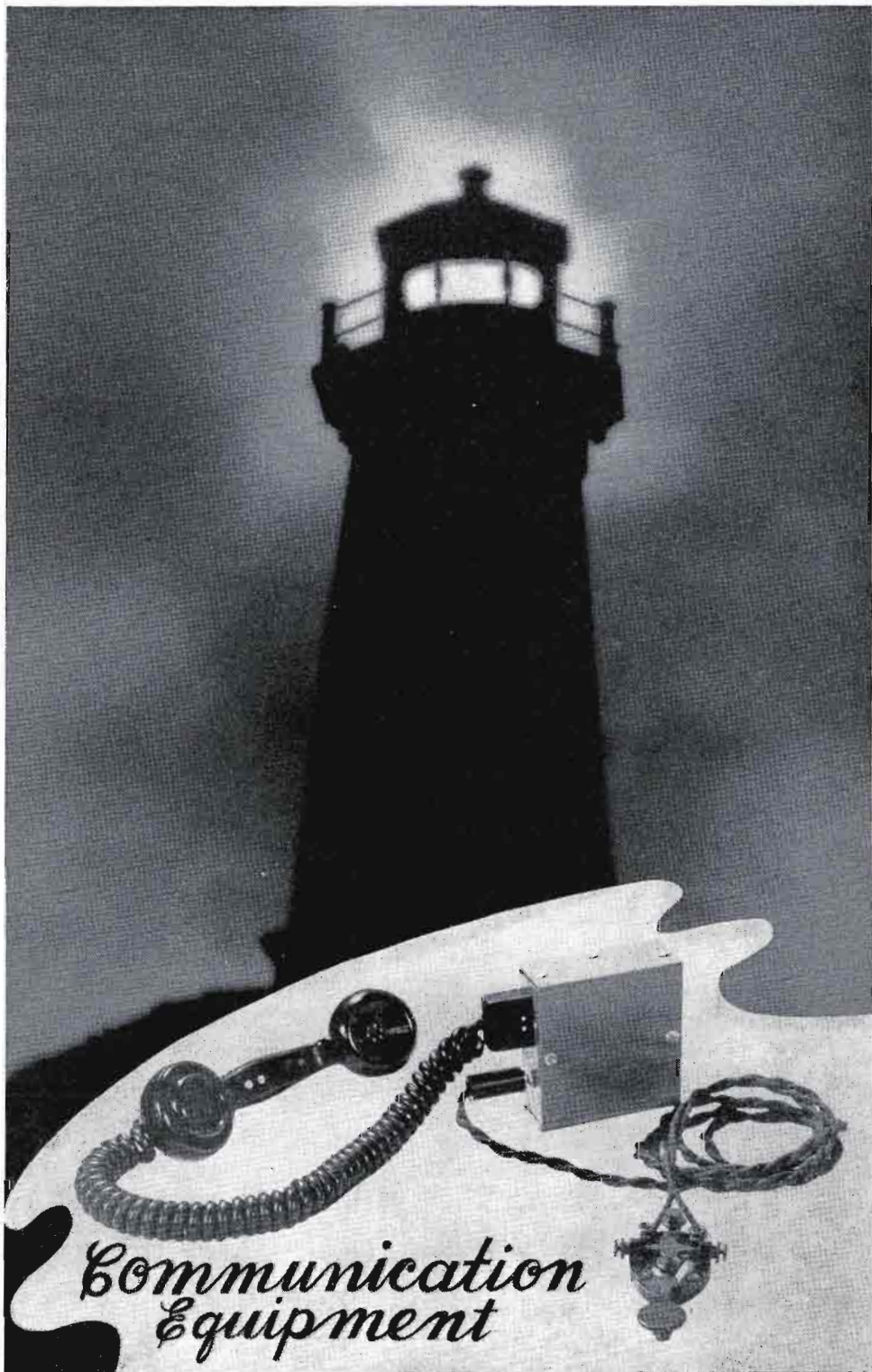

*Communication
Equipment*

GATES

191

GATES

5000/10,000 WATT

HIGH FREQUENCY TRANSMITTERS

In the medium high powered field, this series of Gates high frequency transmitters has established a world-wide reputation in both telephone, telegraph and short wave broadcasting service. — Selected by many governments as well as private companies, the HF5 and HF10 transmitters handle millions of words of international press copy annually. Are used for transcontinental and transoceanic telephone, while scores are in use as high quality short wave broadcast transmitters for both music and voice.

Ten models are available, differing only in mode of transmission. These models may be had in a choice of two frequency ranges, either 2-22 Mc or 2-32 Mc. Also where a single operating frequency is desired, such as in short wave broadcasting, these models are available at lesser cost. — Telegraph models are equipped with electronic keying for speeds up to 400 WPM and may also be adapted to frequency shift keying.

All models are rugged commercial grade transmitters that may be operated 24 hours a day under a wide variety of temperature, humidity and altitude conditions. — Full description will be found on the following pages.

GATES RADIO COMPANY

Manufacturing Engineers Since 1922

QUINCY, ILLINOIS, U. S. A.

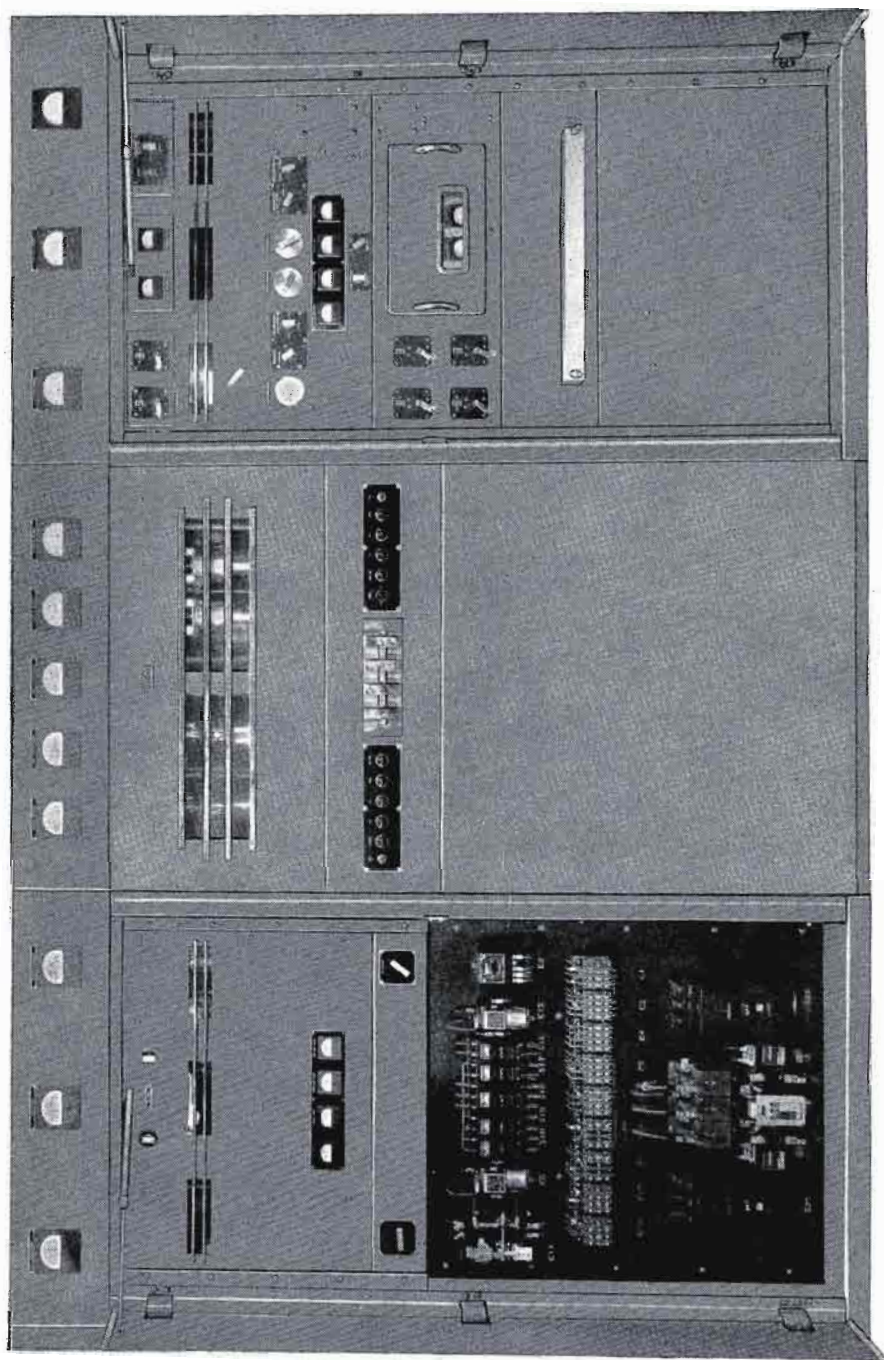

Front view (doors open) of Gates 5000 and 10,000 watt high frequency transmitters, Models HF5 and HF10.

HF5 and HF10, 5 and 10KW Transmitters

MODELS AVAILABLE for 5 and 10KW service are listed on Page 199. Whether the need is for voice quality modulation, broadcast quality, telegraph or combinations of telegraph and telephone, you will find a model exactly as required. Telegraph models will key with perfect square top wave form up to 400 WPM, and excellently up to 600 WPM. Frequency shift keying is adaptable to all models.

TUBE COMPLEMENT is shown on Page 201 and in the block diagram on Page 200. Particular note should be made of the 3X2500F3 tubes used in all models in the radio frequency and modulator stages. These low cost, long life tubes mean much in high operating efficiency and low hourly operating cost.

BAND CHANGING is quick and effective. All circuits are continuously variable and tuned from the front panel—with exception of the final tank coil. The Gates "latch on" system allows fast changing of this coil and completely eliminates complicated and costly tuning mechanisms. Four final tank coils are provided to cover the range from 2 to 22 megacycles. One additional set to 32 megacycles. Pi-network tuning is also continuously variable.

AUDIO has four stages, with abundance of drive and modulation capacity. Broadcast models employ both modulation transformer and reactor, while voice models are equipped with the new and exclusive Gates designed Hi-cap modulation transformer. This eliminates the modulation reactor—and yet, adds to modulator efficiency at voice frequencies.

POWER SUPPLIES are generous in both size and number. Main supply is full wave, three phase, utilizing either six 8008 or 673 tubes, depending on model selected. Separate supplies are incorporated for low voltage and bias circuits. All power supplies are carefully guarded by the relay protective system outlined below.

PROTECTIVE DESIGN is very complete. It includes primary circuit breakers in all major circuits and individual supervisory relays in all overload circuits such as RF driver, audio driver, final amplifier, modulator, air failure and exciter failure. Time delay, door interlock and pressure type blower air interlock protective equipment are all standard equipment. 26 protective devices in all.

(continued next page)

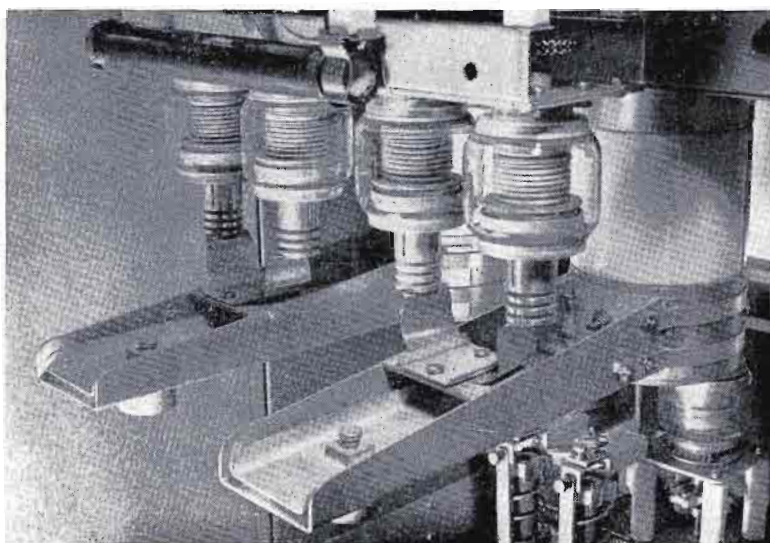

5/10KW High Frequency Transmitters

RECYCLING is part of the HF5 and HF10 transmitter design. If, for any reason, the carrier should go off the air, the transmitter will automatically turn itself back on four times. Thus, in case of a static discharge, such as across the base of a tower, the transmitter will automatically turn back on.

COOLING is provided by one large squirrel cage blower which sends a torrent of air to the four 3X2500F3 tubes—with excess air blowing into the transmitter proper. A diaphragm air pressure switch protects the tubes against air failure, and even a clogged air filter will activate the diaphragm pressure switch. An additional small blower feeds a small stream of air to the base of each high voltage mercury vapor rectifier tube.

LOADING from the push-pull power amplifier is balanced, and will match from 300 to 800 ohm lines. Veeder counter dials on the variable pi-network coils allow accurate logging for frequency change.

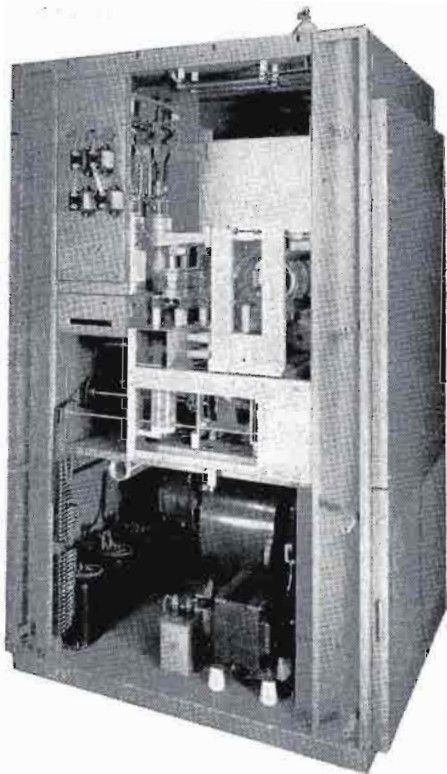

Center cubicle of HF5 and HF10 transmitters. Well illustrated is the large squirrel cage blower at the bottom.

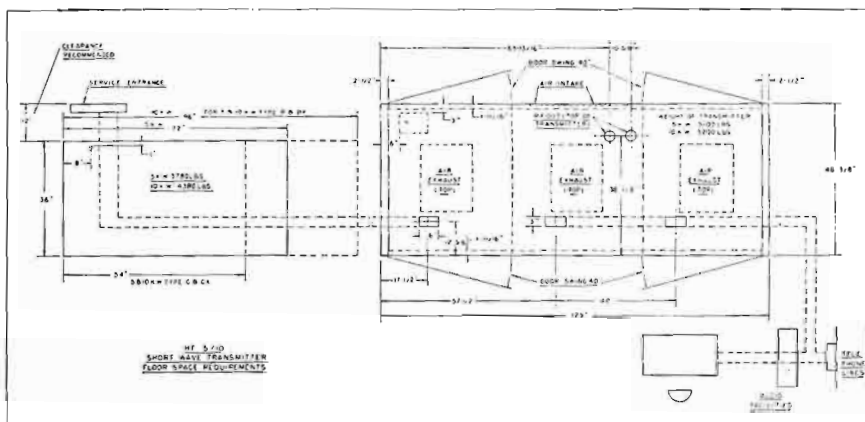

Floor plan shows location and size of transmitter and external modulator/power components. External components may also be mounted in basement or in out-building if desired.

HF5/10 Rugged Design

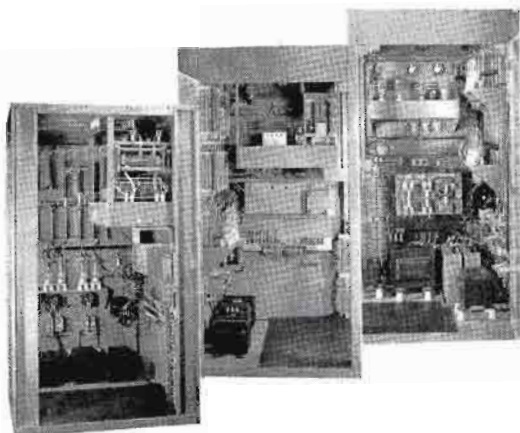
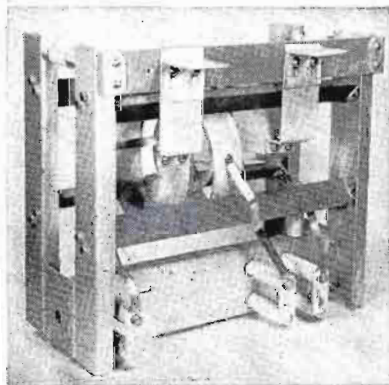
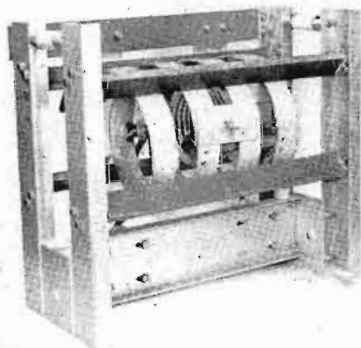
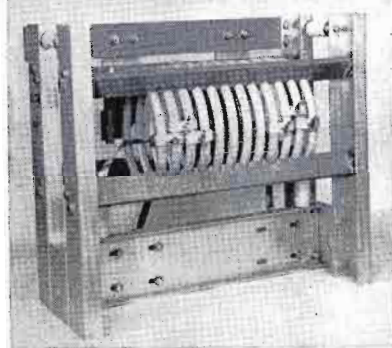
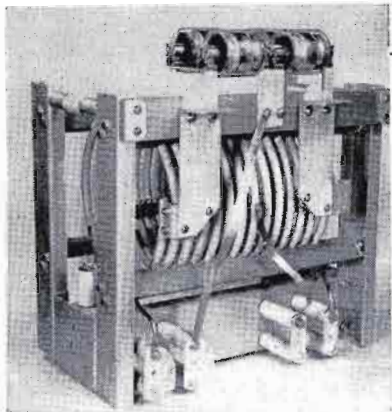

Left, are the four latch-on tank coils that cover the 2-22 Mc band. An added bar type horseshoe coil is supplied where coverage to 32 Mc is desired. Coils are silver plated and micalex insulated. — Above, 3 pictures of the internal construction. From left to right, side view of RF exciter cubicle, rear view of exciter cubicle, and rear view of rectifier/protective circuit/audio deck.

Below, the trio of oil filled power, modulation and reactor transformers. These 3 units weigh 2400 lbs. and are one of the reasons why Gates HF5 and HF10 transmitters have the world-wide confidence of the engineering profession.

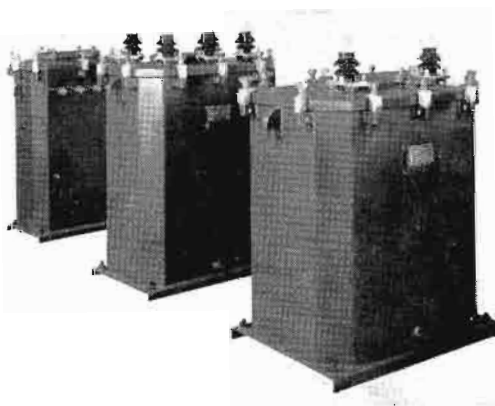

HF5 and HF10 Transmitters Available to 32 Mc

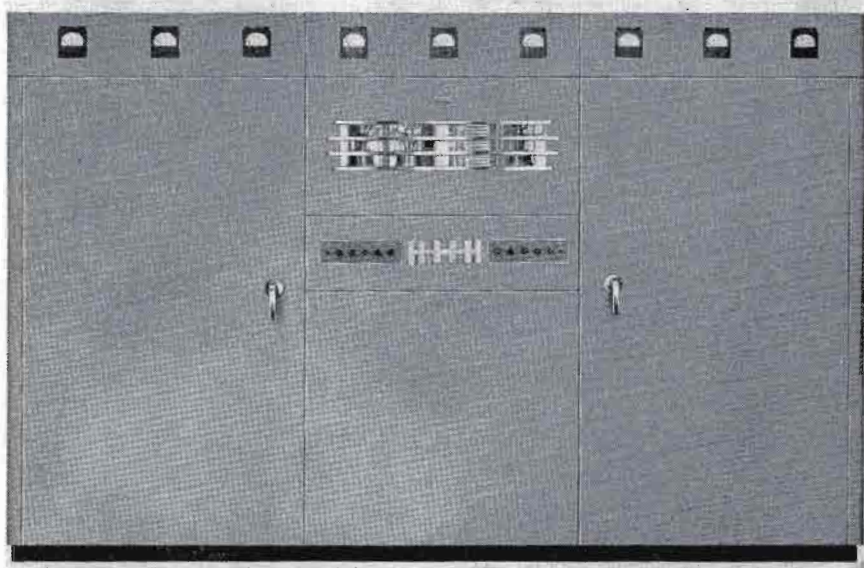

With front doors closed, all tuning controls are fully protected. Dead front design permits opening doors at any time for touch-up tuning and checking.

CONSTRUCTION

All models consist of three cubicles or cabinets. Cubicles join together with tie bolts and are electrically interconnected with jumper between terminal strips. This eliminates any cabling at time of installation. Left cubicle is the rectifier, control circuit, audio driver unit. Center cubicle contains the power amplifier and modulation tubes. Right cubicle is the RF driver and supervisory control section. Full length front and back doors are provided.

Layout design is such that the attendant may walk inside the back—rubber mats are provided. Such refinement as automatic internal lights that turn on when the back door is opened, and utility receptacles for drop cords or soldering iron are standard equipment.

Floor space for the three transmitter cubicles is only 125" wide and 48" deep, exclusive of door swing. In modulated models the heavy oil filled power, modulation and reactor transformers are external and may be mounted either indoors or outdoors. Telegraph models have the power transformer self-contained. Rugged construction is emphasized. HF5 and HF10 transmitters are known as good shippers and reports halfway around the world state arrival in perfect condition. — Heavy cold rolled furniture steel, resistance and seam welded, is fabricated into a channel type design. Cabinets are attractively finished in medium gloss gray. Crackle finishes are not used. Hardware is in chrome, nickel and brushed aluminum with escutcheons in etched aluminum.

Design meets all requirements of good engineering practice in all countries where exacting regulations exist.

(continued next page)

HF5 and HF10 Transmitter Applications

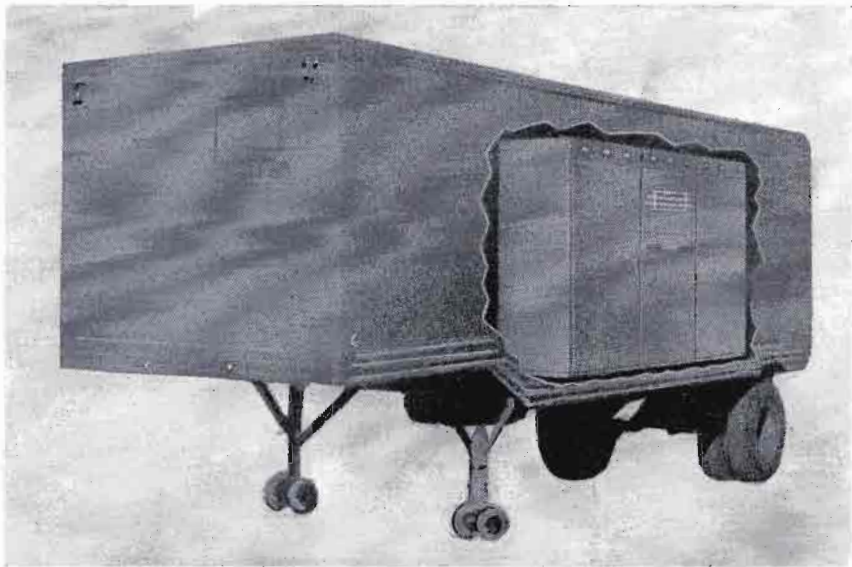

Illustrated above is a 10KW transmitter mounted in a standard 26-foot trailer. In this case, trailer accommodates transmitter, audio input equipment, heating and air-conditioning equipment. Eliminating air-conditioner makes room available for crew's quarters or small studio for announcer. Power plant is usually pulled behind trailer by means of a smaller trailer. Gates can provide all equipment including trailer. Power plants on Page 243.

Below is pictured a group of three Gates 5KW and 10KW transmitters in use at Radio El Salvador. Two high frequency and one medium frequency broadcast transmitters send a strong signal throughout North and South America.

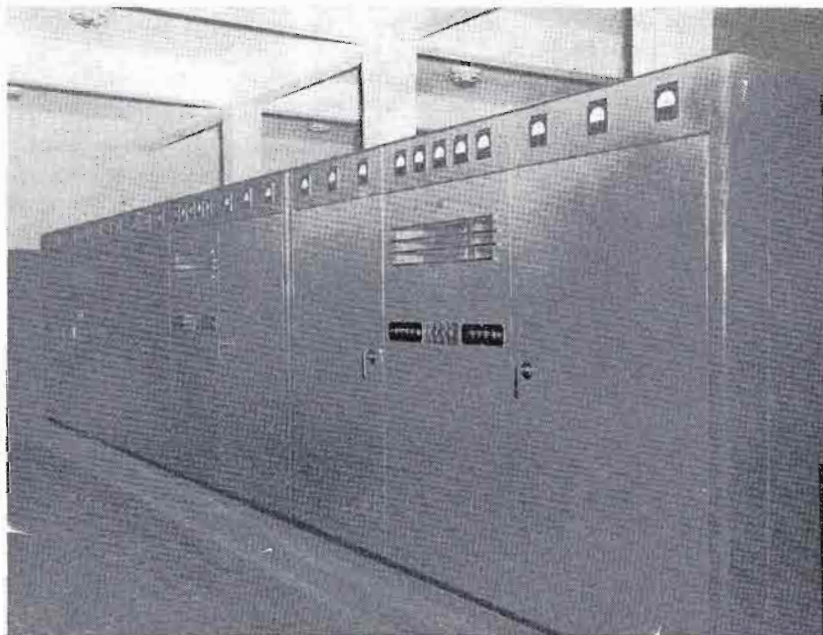

HF5 and HF10 High Frequency Transmitters

Ten Models To Choose From—

Models listed below are for 2-22 Mc operation. Where desired for 2-32 Mc operation, the number 32 should appear after the model number. For example, HF5B would be 2-22 Mc. HF5B-32 would be 2-32 Mc. In the pink supplementary price list at the back of this book, prices are shown for all models as well as subtractions where only one or two selected frequencies are desired.

- (1) **HF5B**, a 5000 watt high frequency broadcast transmitter employing high level modulation, operating from 2-22 Mc with uniform audio frequency response within 2 db from 30 to 10,000 cycles.
- (2) **HF5BX**, the same transmitter as the HF5B, for high frequency international broadcasting but has high speed keyer added so transmitter may be utilized for both high quality broadcasting and high speed telegraph service.
- (3) **HF5C**, a telephone type communications transmitter similar in all respects to the HF5B but with the audio frequency portion designed for communications service only. This allows elimination of the modulation reactor and other alterations in audio frequency components, providing economies where only voice communications will be employed and the wide frequency response and extremely low distortion content of the HF5B is not necessary.
- (4) **HF5CX**, an identical transmitter to the HF5C but with high speed electronic keyer added, providing telephone and telegraph transmission.
- (5) **HF5TX**, a 5000 watt telegraph transmitter only with high speed electronic keying up to 600 WPM.
- (6) **HF10B**, high frequency broadcast transmitter, 10,000 watts output from 2-22 Mc with high level modulation and uniform audio frequency response within 2 db between 30 and 10,000 cycles. For international radio broadcasting at high frequencies, no finer 10,000 watt equipment has ever been constructed.
- (7) **HF10BX**, a 10,000 watt radio transmitter identical to the HF10B but having added a high speed electronic keyer, providing a high quality 10,000 watt broadcast and telegraph transmitter for use between 2-22 Mc.
- (8) **HF10C**, a 10,000 watt communications type telephone transmitter with its audio components designed for voice quality transmission only, and in other respects identical to the HF10B transmitter. For international telephone communications no finer 10,000 watt radio transmitter has ever been constructed.
- (9) **HF10CX**, an identical transmitter to the HF10C but with high speed electronic keyer added and providing a 10KW telephone and telegraph transmitter.
- (10) **HF10TX**, a telegraph transmitter producing 10KW power over a wide band of frequencies between 2-22 Mc. The high speed electronic keyer is part of the equipment.

Functional Diagram HF5 and HF10 Transmitters

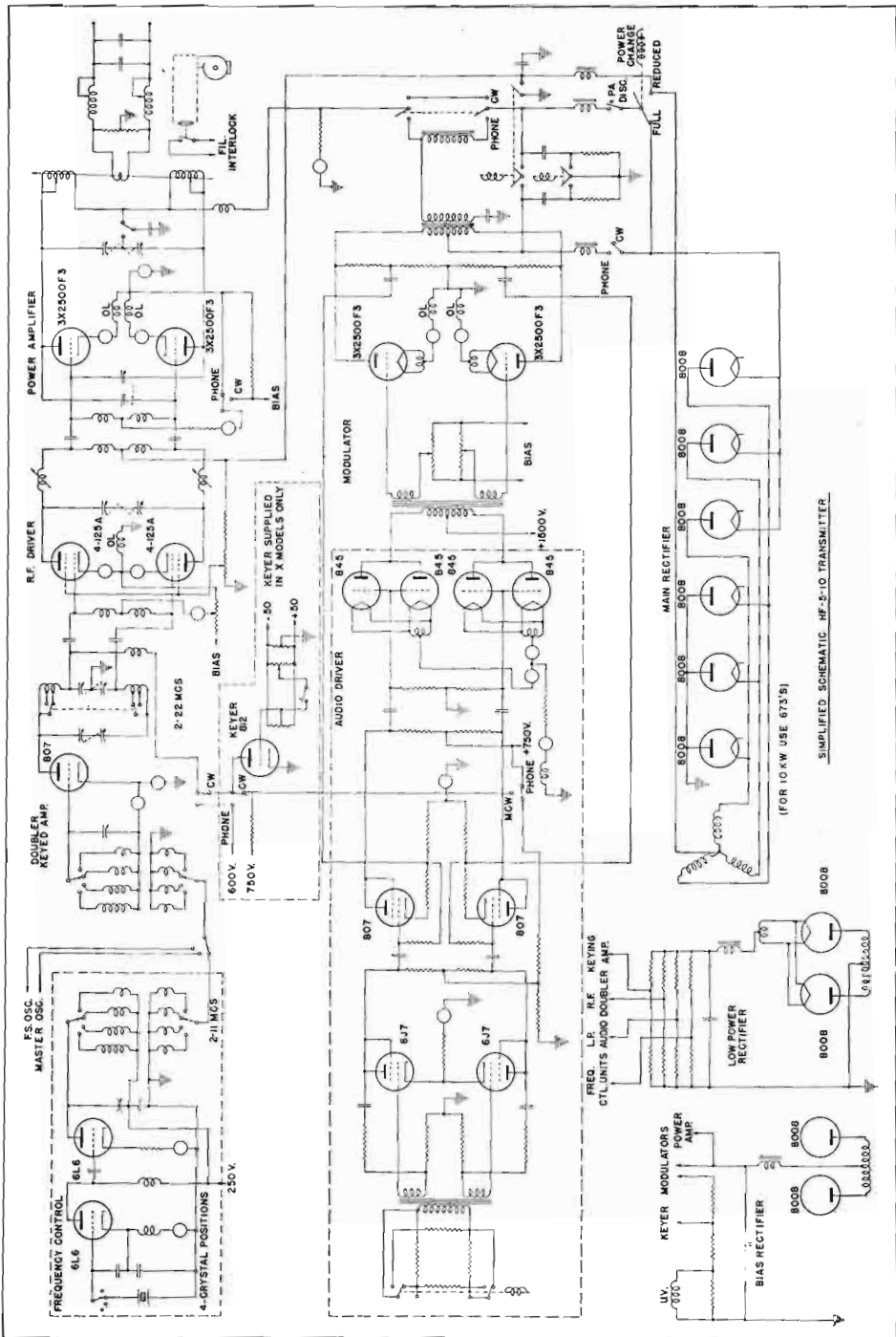

Specifications --- Ordering Data HF5-HF10

SPECIFICATIONS

TUBES (all models): One 812. Two each 6L6, 4-125A, 6J7. Three each 807. Four each 845, 3X2500F3. Ten each 800B.

NOTE: In 10KW model, six type 673 replace six type 800B in main rectifier. In telegraph model, delete two each 6J7, 807, 3X2500F3, and four 845. Where keyer not employed, delete 812.

METERING: Individual meters provided for—oscillator plate, first int. amp. plate, second int. amp. grid, second int. amp. plate, third int. amp. grid, third int. amp. plates (2 meters), power amp. grid, power amp. plates (2 meters), first audio plates, second audio plates, third audio plates (2 meters), modulator plates (2 meters), filament volts, plate volts. (Telegraph models have audio meters omitted.)

FREQUENCY RANGE: Standard models 2-22 Mc, available 2-32 Mc also (see ordering information below). — All circuits continuously variable from front panel except latch-on tank coil. Four tank coils cover 2-22 Mc. Five for 2-32 Mc.

POWER OUTPUT: Model HF5 (all models), 5000 watts carrier. Model HF10 (all models), 10,000 watts carrier.

NOTE: Under certain circumstances power output above 18 Mc will be slightly lower.

OUTPUT IMPEDANCE: 300-800 ohms balanced.

FREQUENCY STABILITY: 0.005%.

CRYSTAL POSITIONS: 4 (additional crystal provisions available on special order).

AUDIO INPUT: 600 ohms; plus 14 dbm for 5KW; plus 17 dbm for 10KW.

AUDIO RESPONSE: HF5B, HF5BX, HF10B, HF10BX: $\pm 1\frac{1}{2}$ db 30-10,000 cycles.

HF5C, HF5CX, HF10C, HF10CX: ± 3 db 200-3000 cycles.

NOTE: Suggest use of M-5263 limiter/filter amplifier, listed Page 233, for HF5C and HF10C for top performance of voice models.

DISTORTION: HF5B, HF5BX, HF10B, HF10BX: $3\frac{1}{2}$ % or less 50-7500 cycles at 95% modulation. HF5C, HF5CX, HF10C, HF10CX: 8% or less 200-3000 cycles at 95% modulation.

NOISE: 60 db or better below 100% modulation, broadcast model; 45 db or better below 100% modulation, communications model.

POWER INPUT: 230 volts, 3 phase, 50/60 cycles.

POWER CONSUMPTION AT 100% MODULATION: HF5B, HF5BX, HF5C, HF5CX approximately 19.5KW. HF10B, HF10BX, HF10C, HF10CX approximately 31KW. HF5TX approximately 10KW. HF10TX approximately 20KW.

KEYING SPEED: 400 WPM with pure square top wave form. Higher practical keying speeds up to 600 WPM easily possible.

SIZE: 125" long, 78" high, 49" deep, with door swing front and back doors add 40". Size of largest cubicle 51" wide, 56" deep, 80" high. Space required for external transformers, where used, 36" wide, 72" long, 36" high.

NET WEIGHT: 5KW telephone models, 6800 lbs.

10KW telephone models, 8100 lbs.

GROSS WEIGHT: 5KW telephone models, 9900 lbs.

10KW telephone models, 10,800 lbs.

CUBAGE: 5KW models, 317 cu. ft.

10KW models, 342 cu. ft.

ORDERING INFORMATION

By Model Number

MODEL HF5B complete 5KW broadcast model, high frequency transmitter with complete coil set 2-22 Mc, one set of tubes, less crystals and ovens.

MODEL HF10B complete 10KW broadcast model with all coils 2-22 Mc, one set of tubes, less crystals and ovens.

MODEL HF5BX complete 5KW broadcast model, same as above but with electronic keyer added, with tubes, complete coil set 2-22 Mc, less crystals and ovens.

MODEL HF10BX complete 10KW broadcast model with electronic keyer added, with tubes, complete coil set 2-22 Mc, one set of tubes but less crystals and ovens.

MODEL HF5C communications telephone transmitter, 5000 watts, with coil set 2-22 Mc, complete set of tubes but less crystals and ovens.

MODEL HF10C communications type telephone transmitter, 10,000 watts, with complete coil set 2-22 Mc, complete set of tubes but less crystals and ovens.

MODEL HF5CX communications telephone and telegraph transmitter, 5000 watts power, with electronic keyer, complete coil set 2-22 Mc, complete set of tubes but less crystals and ovens.

MODEL HF10CX communications telephone and telegraph transmitter, 10,000 watts power, with electronic keyer, complete coil set 2-22 Mc, complete set of tubes but less crystals and ovens.

MODEL HF5TX telegraph transmitter only, 5000 watts, with complete coil set 2-22 Mc, high speed electronic keyer, complete set of tubes but less crystals and ovens.

MODEL HF10TX telegraph transmitter only, 10,000 watts, with complete coil set 2-22 Mc, complete set of tubes but less crystals and ovens.

MODEL JK03H17 crystal and oven ready to use with any of above transmitters. Specify carrier frequency desired when ordering.

MODEL TK-252 complete 100% tube set for 5KW telephone models.

MODEL TK-253 complete 100% tube set for 10KW telephone models.

MODEL TK-254 complete 100% tube set for 5KW telegraph models.

MODEL TK-255 complete 100% tube set for 10KW telegraph models.

MODEL TK-256 set for electronic keyer.

For 2-32 Mc, add the number 32 behind type number. Example, HF5B for 2-32 Mc would be type HF5B-32.

PRICES: All models on pink supplement in rear of catalog.

GATES

201

2-32 MC OSCILLATOR-AMPLIFIER

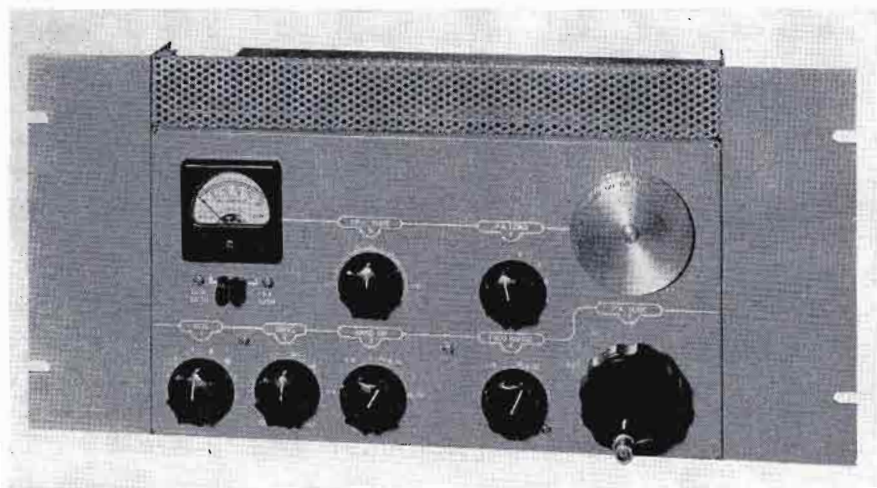

Consists of an oscillator, amplifier doubler and 65 watt (output) power amplifier to continuously cover all frequencies, by front panel tuning, from 2 to 32 Mc. — Rack or desk cabinet mounts. Panel size: 8 $\frac{3}{4}$ "x19" and 9 $\frac{1}{2}$ " deep.

Design is around an untuned oscillator that selects into 10 crystal positions. Crystals may be had for either 0.02% or 0.005% accuracy. The oscillator feeds an amplifier/doubler stage which, in turn, feeds two 6146 output tubes producing a full 65 watts output. This output may be reduced by use of lower than maximum plate voltage and coupling variations in case the use does not demand maximum output. — Front panel tuning includes: (1) crystal selector switch, (2) RF drive, (3) band switch IPA, (4) frequency range PA, (5) IPA resonance, (6) PA loading, and (7) PA resonance. — Top grill is for front of cabinet ventilation to assure adequate cooling when mounted in rack directly next to another unit.

SPECIFICATIONS

FREQUENCY RANGE: 2-32 Mc continuously variable.
POWER OUTPUT: 85 watts CW, 65 watts CCS and/or modulated.
OUTPUT IMPEDANCE: 30-300 ohms, unbalanced.
POWER REQUIRED: 6.3 volts AC at 3.5 amps. 500 volts DC at 200 MA.
Lower plate voltage and current may be employed for less output.
CRYSTAL INPUT: Accommodates 10 crystals. For 0.02% order type H7. For 0.005% accuracy, order H17 in JK02 temperature controlled holder. Two H17 crystals fit in one JK02 holder.
KEYING: In oscillator cathode only, first IPA cathode only or both. Keying speed 60 WPM. Electronic keyer may be added.
TUBES: 5763 osc, 5763 IPA, (2) 6146 output, (1) OB2 regulator, 6AQ5 screen clamper.
SIZE: 8 $\frac{3}{4}$ " high, 19" wide, 9 $\frac{1}{2}$ " deep.
FINISH: Gloss gray with lettering in white.

ORDERING INFORMATION

Cat. No.

Exciter/amplifier with tubes, less crystals	M-5239
Crystal and holder for 0.02% accuracy	H7
Crystal and holder for 0.005% accuracy when used with JK02	H17
Temperature controlled oven for H17 crystals	JK02
100% spare tube complement	TK-250

NOTE: Prices stated on pink supplement in rear of catalog. Be sure to state crystal frequencies when ordering.

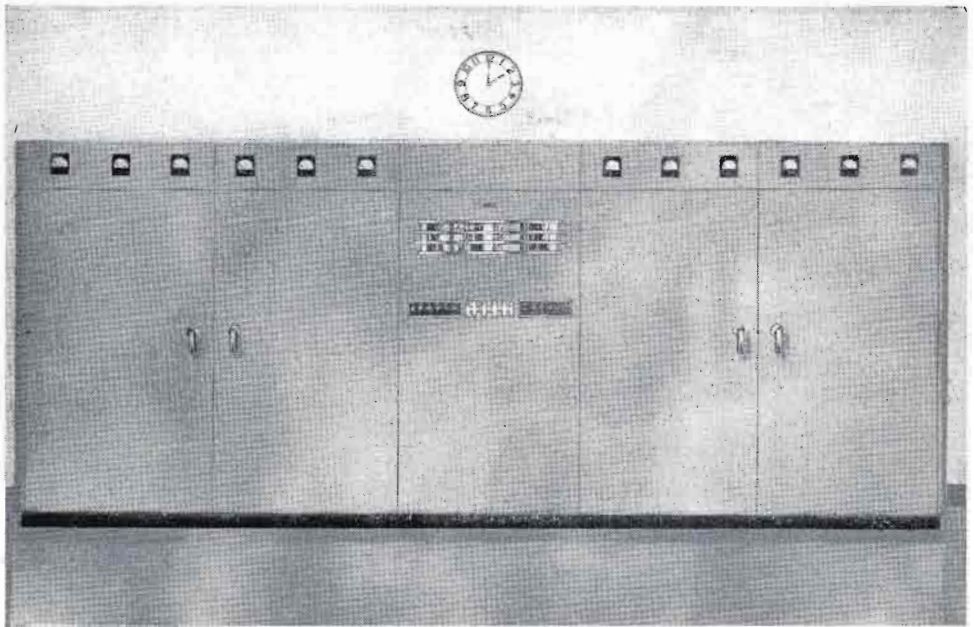

GATES 20KW TRANSMITTERS

(For high frequency service in phone, CW and broadcasting)

This very popular transmitter in the higher powered field of short wave communications offers the commercial user either a broadcast, telephone or telegraph transmitter of the very highest commercial quality.

Featuring a low cost long-life tube complement, splendid serviceable construction, ease of installation, high level Class B modulation in the telephone models, along with that type of straightforward heavy construction that has long made Gates transmitters a favorite of industrial users.

Full description of this transmitter will be found on Pages 6 through 12.

GATES RADIO COMPANY

Manufacturing Engineers Since 1922

QUINCY, ILLINOIS, U. S. A.

GATES

65 WATT 2-32 MC PHONE/CW TRANSMITTER



A complete transmitter for telephone and telegraph, continuously tuning the entire high frequency range of 2-32 Mc. Constructed in two desk type cabinets that may be placed either side by side (illustrated next page) or one above the other as shown above. — High level Class AB modulation is employed for telephone. The audio amplifier includes peak limiting amplifier, 3000 cycle cut-off filter, and proper amplification for use with a Hi-Z low level microphone. — Metering includes cathode current of all RF stages of the RF section and compression-modulator current in the audio section.

Transmitter keys in one of three choices: oscillator cathode, IPA cathode, or both. This system is excellent for break-in. Off-On for phone is by means of a front panel switch. Breaking the carrier by the same system as keying is also often preferred for phone operation. Power rating of 65 watts is output power fully modulated. CW rating only is 85 watts.

THE NEW GATES 1000 WATT 2-32 MC SHORT WAVE TELEPHONE, TELEGRAPH OR BROADCAST TRANSMITTER

To the long line of illustrious Gates high frequency transmitters is added this new model HF-1M. — Supplies 1000 watts output power that may be 100% modulated for either communications or broadcast. When keyed, powers in excess of 1KW output are possible.

High frequency coverage between 2 and 32 Mc at full power output is continually variable from the front panel between 3-32 Mc. This means fast frequency change without changing any components, or as simple as changing dial settings.

HF-1M is an all-purpose transmitter. All modulation components are of broadcast quality. Where the wide audio range for broadcasting is not desired, the Gates limiter-filter amplifier, listed on Page 233, is added for sharp voice quality. Keying up to 60 WPM manual including break-in may be augmented with an optional electronic keyer for speeds up to 400 WPM.

Designed to operate as a commercial around-the-clock transmitter, the construction is heavy and design is conservative. With all of this, the price is modest. Fourth in a series of "Hi-Watter" transmitters, see Pages 23-26, the buyer receives far greater value per dollar invested, through quantity manufacturing methods in combining several similar models on one production line.

HF-1M SHORT WAVE TRANSMITTER

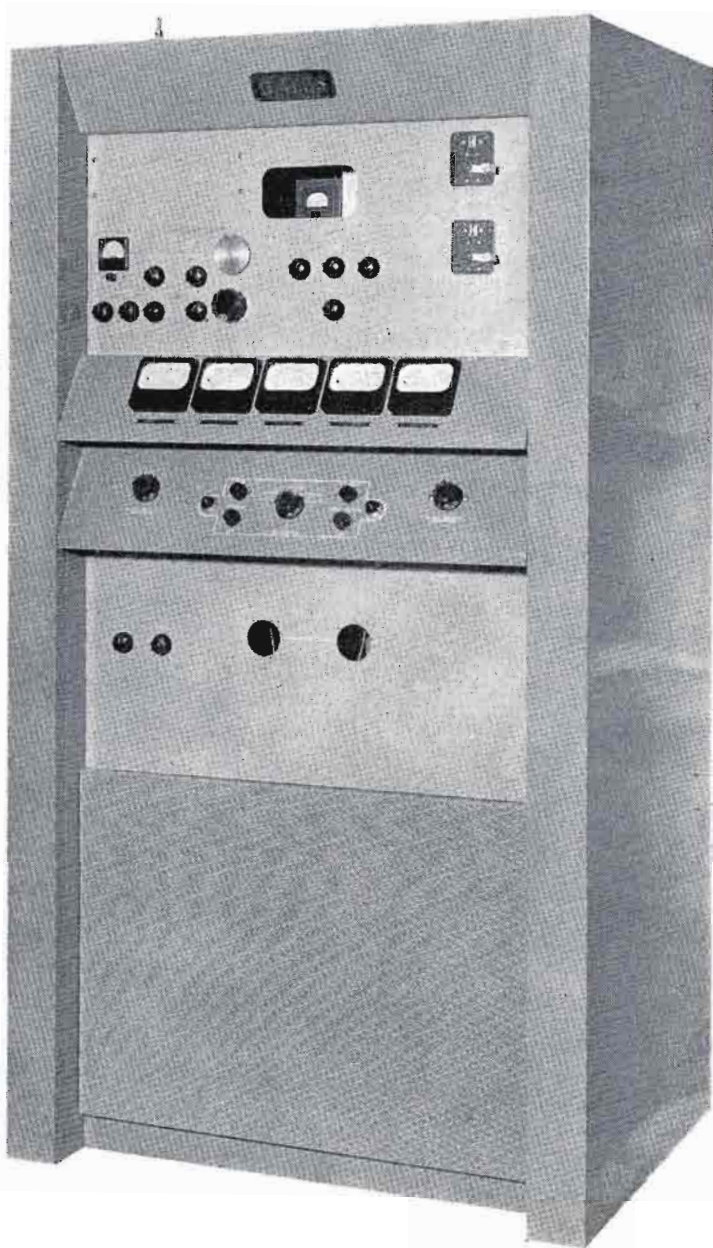

The HF-1M short wave transmitter. 1000 watts output. For either telephone, telegraph or broadcast. Range 2-32 Mc.

GATES

207

HF-1M Continuously Variable 1KW Transmitter



Spotlite On the Exciter:

Heart of the HF-1M high frequency transmitter is the M-5239 exciter, pictured above. Accommodates 10 crystals in either open holders (0.02% accuracy) or in temperature controlled ovens (0.005% accuracy). Completely self-contained including metering, this exciter delivers up to 85W output to drive the final power amplifier directly. — Entire tune-up of the transmitter to the final stage is simple and quick. Select desired crystal frequency, set band change controls to proper frequency range and resonate. Logging for resonance is restricted to only two controls as oscillator is untuned. Has three stages; 6CL6 osc., 5763 amp. doubler and (2) 6146 output. A 6AQ5 screen clamper and OB2 regulator tube also employed. Keying or break-in is optional three ways: (1) oscillator cathode only, (2) IPA cathode only, or (3) both.

The result of many months of research, the ease in handling and complete stability at all frequencies is an important contribution to the fine overall performance of the HF-1M transmitter.

(continued next page)

FULL 1000 WATTS OUTPUT 2-32 MC

Spotlite the Power Amplifier:

In high frequency service there is no substitute for conservative design. Abundance of excess power is available in the HF-1M by use of the single 4-1000A blower cooled power amplifier tube in conjunction with large tank components. Only two tuned circuits, both operated with counter type front panel controls, permitting 1/10 revolution logging. Set the PA tuning and loading controls to desired frequency and you are ready to operate.

Continually variable rotating coils, ganged for one dial operation, tune the PA stage from 3-32 Mc at full 1000 watts output power. Where operation is below 3 Mc a padder is added. For greater convenience and reliability a low power tune-up switch has been incorporated. This allows the operator to check exact resonance before applying full power.

Use of the 4-1000A power amplifier offers several outstanding features not usually found in this type of equipment. Most important is the tube rating actually capable of over 1500 watts output which means long life at 1000 watts. Use of only one tube in the final amplifier has definite advantages over multiple tubes. The single ended output lends to greater stability and use of low impedance transmission lines with minimum tuning.

(continued next page)

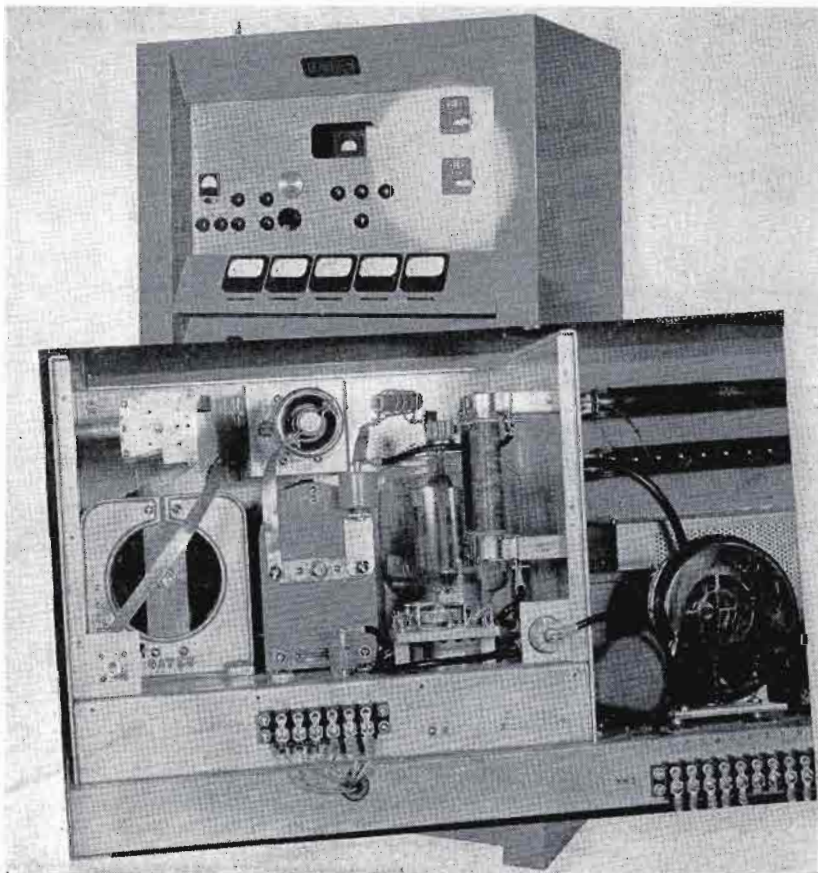

HF-1M High Frequency CW/Phone Transmitter

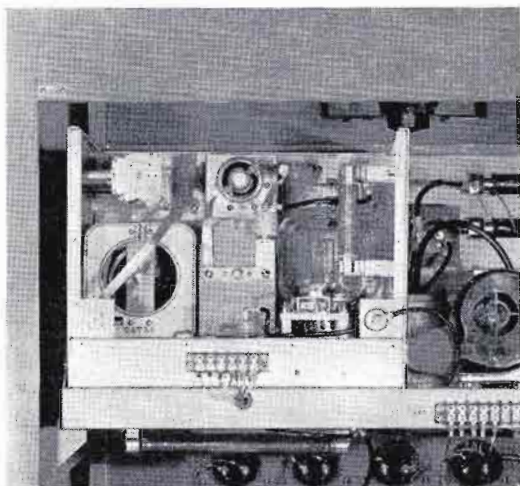
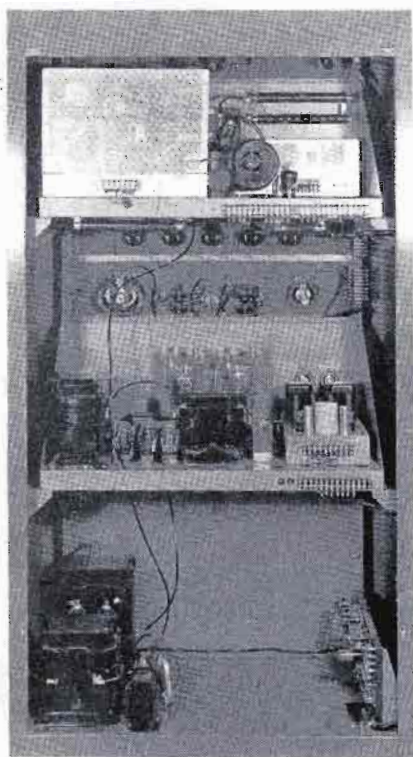

Rear view HF-1M transmitter. Illustration directly above is open view of the 1KW power amplifier. The big 1KW power tube is in the right-hand section of the shielded compartment. — Left illustration, rear view. From top to bottom: radio frequency section, meter panel, control panel, audio and low voltage power supply section and at bottom right the relay control panel and bottom left, main power supply.

Outstanding HF-1M Features:

- 1 — Continuously variable by front panel control 3-32 Mc at full 1KW output, voice or CW. Where 2 Mc is desired, a simple paddler is added.
- 2 — Audio system either for broadcast or voice. When voice only, used with M-5263 limiter/filter amplifier, fully described Page 233.
- 3 — Complete relay system including: (a) Fil. on relay, (b) Plate on relay, (c) Time delay relay, (d) PA overload relay, (e) Mod. overload relay and (f) Underdrive relay. The ideal system for complete protection and extension of operating control functions.
- 4 — High level Class B modulation with twin-drive audio for full reliability, low distortion and long tube life through 833A modulators.
- 5 — 230 volt, 50 or 60 cycles, single phase operation. Main power supply has 2-section choke filter for superior regulation and low ripple content.
- 6 — Servicing ease and maintenance. Only one cable interconnects entire transmitter. RF and audio decks instantly removable to clean or service. Roomy construction along with blower and suction fan assures excellent cooling of all components.
- 7 — Center line metering with large 4" meters reading all necessary metered circuits.
- 8 — Low cost tube complement by reason of low initial cost and long operating life.
- 9 — Easy installation. The HF-1M is supplied 100% finished. No cable to form, no parts to add. It is ready to operate.

HF-1M SPECIFICATIONS

- FREQUENCY RANGE:** 2-32 Mc. Continuously variable by front panel tuning
3-32 Mc. Padder added for 2 Mc. operation.
- POWER OUTPUT:** 1000 watts 100% modulated at all frequencies.
Slightly higher power where CW only.
- TYPE OF OUTPUT:** Single ended, full Tee network.
- OUTPUT IMPEDANCE:** 49/73 ohms. Where other output impedances are desired, special coupling units are available to match customer requirements. See Page 212.
- RF STABILITY:** Where used with JK02 temperature controlled oven, 0.005%.
Where used with H-7 holder, 0.02%.
- NUMBER OF CRYSTALS:** Ten crystal positions. Where JK02 temperature controlled oven is used, 2 crystals are used in each oven. For non-temperature controlled crystals, up to ten Type H-7 crystals and holders may be accommodated. Crystal switching from front panel.
- KEYING:** 60 WPM or may be used with FSK or electronic keyer for higher speeds. 3 keying circuit choices: (a) oscillator cathode only, (b) first IPA cathode only, (c) both oscillator and first IPA cathode. Permits complete break-in for all modes including voice.
- AUDIO INPUT:** 10 db \pm 2 db as broadcast transmitter. When used with M-5263 limiter/filter amplifier (below), input is for either low level microphone or 600 ohm line.
- FREQUENCY RESPONSE:** As broadcast transmitter \pm 2 db 50-7500 cycles.
 \pm 2 1/2 db 30-10,000 cycles. As communications transmitter (when used with M-5263 limiter/filter amplifier) \pm 2 1/2 db 200-2500 cycles with sharp cut-off above 2500 cycles.
- DISTORTION:** 3 1/2 % or less 50-7500 cycles at 95 % modulation.
- MODULATION:** High level Class B.
- POWER INPUT:** 230 volts single phase 50/60 cycles. Consumption at 0% modulation or CW, 3200 watts. At average modulation, 4500 watts.
- CARRIER SHIFT:** 3% or less at 100% modulation.
- SIZE:** 78" high, 42" wide, 30" deep. Floor space 8.7 sq. ft.
- WEIGHT:** 1095 lbs. packed. 846 lbs. net. Cubage, 97.
- COOLING:** Squirrel cage blower cools final power tube and PA. Fan in ceiling of transmitter completes circulation through grill intake at bottom front.
- TUBES:** (Radio frequency) 6CL6 osc., 5763 amp. doubler, (2) 6146 drivers, 4-1000A power amp., OB2 regulator, (2) 6Y6G clampers, (audio) (2) 6SN7 input, (4) 1622/6L6G drivers, (2) 833A modulators.
Power supplies: (4) 5R4GY, (2) 8008.

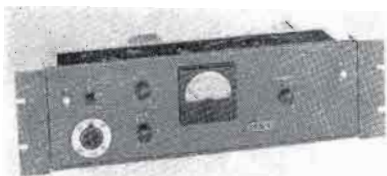

Communications Limiter/Filter Amplifier

Designed for use with the HF-1M transmitter where audio requirements are for voice frequencies only and where clear, crisp voice quality makes intelligibility of greatest importance. Includes peak limiting amplifier to keep modulation level always high without over-modulation. May be used with Hi-Z microphone or 600 ohm input line. Frequency response 200-2500 cycles. Fully described on Page 233.

HF-1M Transmitter --- Ordering Data

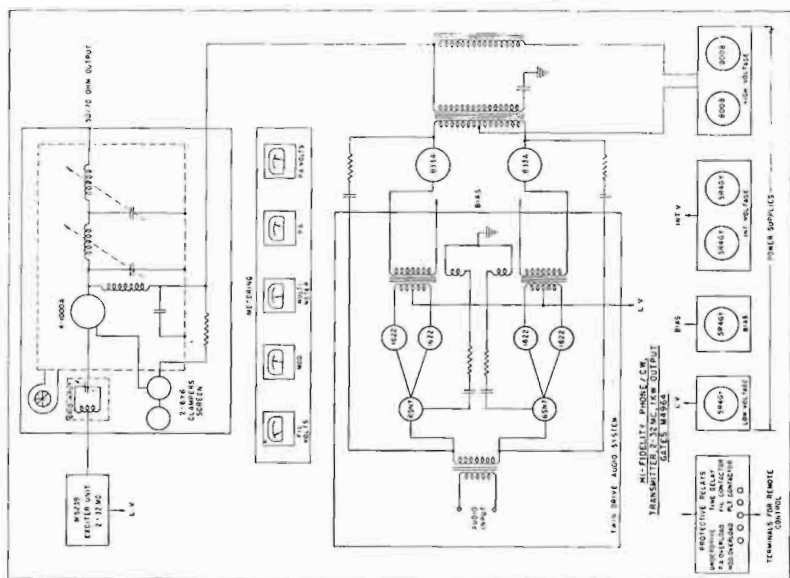

Special Line and Antenna Couplers

Requirements of antennas are wide and varied in communications. Likewise, multi-band operation is sometimes served by use of multiple antennas. The RF output impedance of the HF-1M transmitter of 49/73 ohms will match standard solid and open dielectric coaxial cable plus many of the more conventional antennas that are designed to match coaxial transmission line.

To handle other requirements, Gates offers two typical couplers. Others are available to meet specific customer needs. Where the M-5355 coupler is used, usually different antennas are employed for each frequency. This gives maximum efficiency at each operating frequency. Couplers may be switched either manually or by relays where couplers are located a distance from the transmitter. Customer should give full data on antenna to be used plus operating frequency, when ordering.

Coupler to match HF-1M transmitter to 600 ohm balanced transmission line M-5355

Coupler to match HF-1M transmitter to any conventional wire or vertical antenna at any single frequency M-5356



Ordering Information

	<u>Cat. No.</u>
High frequency transmitter complete with one set of tubes, less crystals	HF-1M
100% spare tube complement for above	TK-249
Crystal and holder for 0.02% accuracy*	H-7
Crystal and holder for 0.005% accuracy (mounts in JK02 oven)**	H-17
Temperature controlled oven (holds one or two H-17)	JK02
Limiter/filter audio amplifier	M-5263

* State frequency when ordering.

** State frequency when ordering. Use only with JK02 oven.

NOTE: Prices shown on pink supplemental price list in back of catalog.

2-26 MC 250 WATT TRANSMITTER

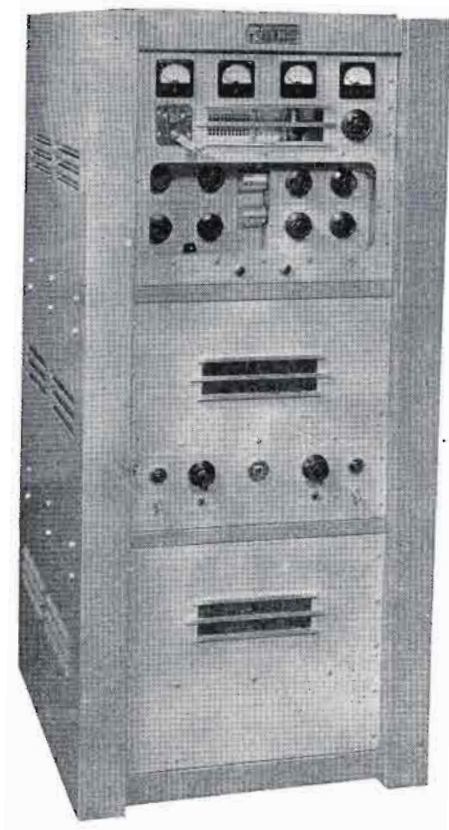

Continually variable 2-26 Mc for telephone and telegraph service at 250 watts output—high level modulated.

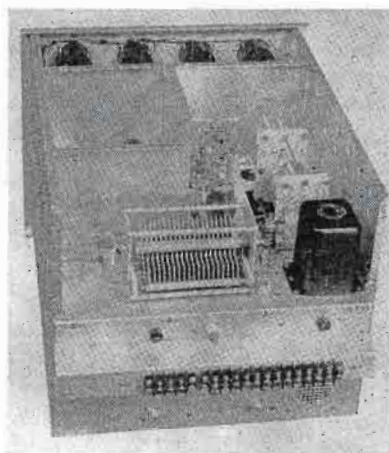

Above: Radio frequency chassis (top deck) with cover removed.

Complete in every detail, the CMG-1 short wave transmitter may be quickly changed in frequency direct from the front panel. Each frequency may be logged and returned to in seconds.

Four crystal inputs, audio system for microphone or line, 3000 cycle cut-off filter, peak limiting amplifier to prevent over-modulation and small overall size, will make this equipment attractive for many commercial uses.

(Continued next page)

2-26 MC 250 WATT TRANSMITTER

GENERAL DESIGN:

Construction is on 3 rugged chassis that mount into the transmitter cabinet and join together with a preformed cable. As each chassis is quickly removable and largely independent of the other, servicing is greatly enhanced. Top chassis is a complete radio frequency unit with output coupling network. Center chassis is the modulator. Bottom chassis is the main power supply.

RF CHASSIS:

3 stages with two 812A power amplifiers produces a full 250 watt carrier at any frequency between 2-26 Mc. Provision is made for 4 crystals which mount (2 per oven) in a JKO-2 temperature controlled oven for .005 % or better stability. Connections for external VFO are provided. There are no plug-in coils or relays to effect frequency change. Dial and veeber counter indicators allow accurate logging for quick frequency change. Output is a Pi-network allowing a wide variety of impedance matching.

MODULATOR:

Includes microphone amplifier with push-to-talk facilities, line input of 500 ohms, peak limiter allowing compression of as much as 25 db with excellent intelligibility, 3000 cycle cutoff filter and high level Class B 811A tubes assure 100 % modulation at all times.

POWER SUPPLIES:

Two provided. Main supply is full wave 866A tubes well filtered. Plate and bias voltages for low stages are supplied by a full wave system with a 5V4 rectifier.

METERING:

Four meters include: (1) PA current; (2) plate voltage; (3) RF output, and (4) multimeter for oscillator plate, IPA grid, IPA plate, PA grid and modulator currents.

Below: Rear view CMG-1 transmitter with door removed for illustrative purposes.

RELAY CIRCUITS:

Standard equipment includes: (1) push-to-talk; (2) receiver muting; (3) vacuum time delay; (4) PA overload, and (5) modulator overload.

CONTROLS:

Filament start switch, plate start switch, overload front panel reset audio gain, PA plate tune, antenna loading, oscillator resonance, IPA resonance, and PA excitation. Pilot lights adjoin starting switches.

OPTIONAL FILTERS:

Though harmonic reduction of the CMG-1 transmitter is excellent, in extreme cases of close proximity to other services an additional second harmonic filter may be desired. Several types are offered (see Ordering Information). Mounted in small shielded container that may be attached in the transmission line circuit.

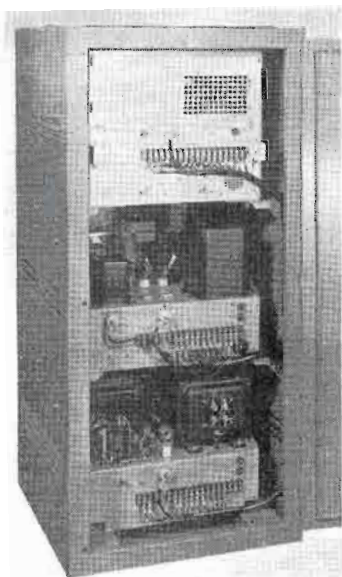

2-26 MC 250 WATT TRANSMITTER

SPECIFICATIONS

FREQUENCY RANGE: 2-26 Mc continuously variable.
POWER OUTPUT: 250 watts.
OUTPUT IMPEDANCE: 40-300 ohms unbalanced. Lower or higher output impedances available at slightly extra cost.
AUDIO INPUT: Hi-Z for microphone at -55 db input. 600 ohms at 0 dbm input level.
FREQUENCY RESPONSE: ± 2 db 200-3000 cycles with sharp cut-off above 3000 cycles.
DISTORTION: Less than 8% at all frequencies 200-3000 cycles. 100% modulation.
MODULATION: High level Class B.
POWER INPUT: 1000 watts at 115 volts, 50/60 cycles, at average modulation.
KEYING SPEED: 60 WPM.
NUMBER OF CRYSTALS: Maximum of four (Type H17 in JKO-2 oven). See Crystals (Index).
STABILITY: When used as above, 0.005%.
VFO INPUT: Provided on receptacle rear terminal board of transmitter.
TUBES: 6AG7 oscillator; 6146 IPA; two 812A PA; two 866/866A rectifiers; 5V4 LV rectifier; 6SJ7 mic amplifier; 6L7 second amplifier and line input; 6C5 third stage; 6L6 driver; PP 811A modulators; 6H6 limiter tube and 5U4G modulator rectifier.
FINISH: Medium gray.
SIZE: 50" high, 23" wide, 26" deep. Door swing 20".
ESTIMATED WEIGHT: 550 lbs. packed. Cubage: 36.



M-4576 microphone includes dynamic microphone, 7' cable and connector with push-to-talk desk stand. Plugs into receptacle on CMG-1 transmitter.

ORDERING INFORMATION

	Cat. No.
Complete transmitter with tubes, less crystals	CMG-1
Crystal in holder (less oven) for 0.02% accuracy	H7
Crystal in holder for .005% accuracy	H17
Oven to accommodate two H17 crystals	JK02
100% spare tube complement	TK-136
Microphone assembly complete	M-4576
Filters for added second harmonic attenuation: For 50 ohms	LPF-52
For 72 ohms	LPF-72
For 250 ohms	LPF-250

NOTE: For prices, see pink price list in back of this catalog. Be sure to state crystal frequency when ordering.

Below: Functional diagram CMG-1 transmitter.

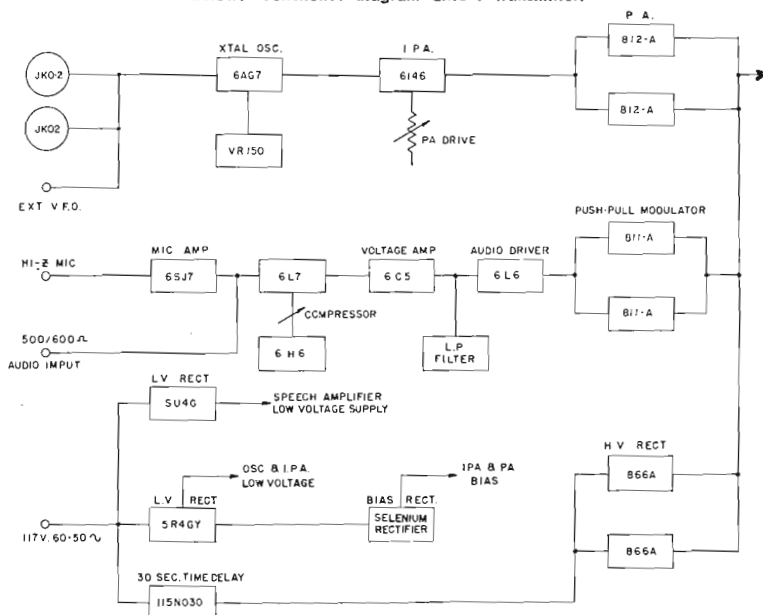

250 WATT UNIT SYSTEM TRANSMITTER



Radio frequency unit, 3 RF stages, temperature controlled oven and crystal, 6V6GT osc., 807 IPA, two 812A power amplifiers in push-pull. Output 50 ohms from variable link. Operates either direct to 50 ohm line or into coupling units listed below. Metering through meter panel on transmitter. Model M3452Y.

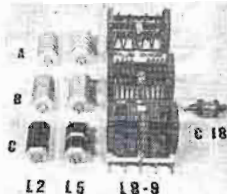

Five coil sets cover the entire 2-22 Mc band. 2-3 Mc coil set also includes small vacuum paddler. For specific frequency operation only the proper coil set is purchased. Likewise additional coil sets may be purchased for any or all frequency coverage. Type number of sets listed with transmitters.



Modulator includes peak limiting amplifier up to 25 db compression, 3000 cycle cut-off filter, microphone amplifier, line input, gain control and front panel microphone connector. 6SJ7 mic stage, 6L7 second stage and line input, 6C5 amp., 6L6 driver and Class B 811A modulators. Model M3453Y.



Control panel used in all models. Used for single or double RF channels. Includes: fil. start, plate start, phone/CW, channel selector, fil./plate pilot lights, meter range switch, plate on relay, keying relay, channel changing relays and overload relay. Meter selector switch reads: osc plate, IPA grid, IPA plate, PA grid. Model M3461Y.

Listed on the next four pages are various models of 250 watt (output) transmitters of the communications type for operation between 2-22 Mc. Described on this page are the major basic units (rear views) that are used in these various models. By following the unit system for many models the purchaser is offered the advantage of standardization of basic design though different models of transmitters are desired. For example, a CW transmitter has the same pertinent units as will be found in the more comprehensive telephone types, but less the modulator, etc.

Each RF chassis may operate on any 2-22 Mc frequency by selecting the proper coil set. Where instant frequency change is not mandatory, the changing coils will suffice. If instant change is desired, then 2 RF decks are used such as in Model M-3449Y (next page).

It can be said that these transmitters are straightforward, "work horse" designs that will produce excellent commercial results at low investment.



Microphone assembly M4237 includes dynamic microphone, 7' cable, plug and push to talk desk stand. Plugs into front of modulator unit on transmitter.

Power supply provides high and intermediate voltages to one RF and one modulator unit or two RF units. Includes bias supply for fixed bias on RF units. Output voltages: 1250V DC, 600V DC and approximately 100V DC for bias. For 115 volts, 50/60 cycles. Tubes: two 866A, one 6X5, 5R4GY. Mounts in base of transmitter cabinet. Model M3454Y.

Dual channel antenna coupler contains two complete networks that may be arranged in T or L with variable loading condenser. Will match wide variety of impedances from 10 to 300 ohms. Changeover relay and 0-3 RF ammeter is provided. Used with two-channel operation such as in M3449Y transmitter, next page. Model M3451Y.

Single channel coupler is identical to the dual channel unit only for one channel. Used in M3491Y transmitter. Includes variable loading control, 0-3 RF ammeter and coupling network that may be arranged either L or T. Matches wide variety of impedances from 10 to 300 ohms. Model M4239.

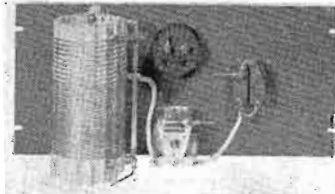
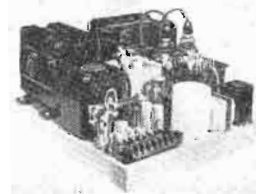

2 CHANNEL PHONE/CW 250 WATTS OUTPUT

A complete telephone and telegraph transmitter with two radio frequency channels providing instantaneous changeover and therefore multi-band operation on two frequencies. Additional frequencies from 2-22 Mc may be accommodated by use of the plug-in coil sets listed below. Individual units comprising this transmitter are generally described on the preceding page entitled, "250 Watt Unit System Transmitters".

Looking at the transmitter illustrations at the right from top to bottom are the following units completely inter-wired and ready to use:

- Dual channel antenna coupling unit, M-3451Y
- Meter panel, M-3460Y
- Radio frequency unit, M-3452Y
- Control panel, M-3461Y
- Modulator unit, M-3453Y
- Power supply unit, M-3454Y

Constructed in 84" rack cabinet, completely wired and ready to use.

SPECIFICATIONS

- FREQUENCY RANGE: 2-22 Mc by coil selection.
- FREQUENCY STABILITY: 0.005 % when used with JKO-2 oven or 0.02 % when used with H7 crystal and holder.
- MODULATION: High level Class B with self-contained peak limiting amplifier and 3000 cycle cutoff filter.
- POWER OUTPUT: 250 watts telephone and telegraph.
- POWER INPUT: 115 volts, 50/60 cycles.
- AF INPUT: Hi-Z for microphone and 600 ohms for line. Push to talk facilities for transmitter On-Off and receiver muting provided.
- RF OUTPUT: 2 channels, each 20-300 ohms.

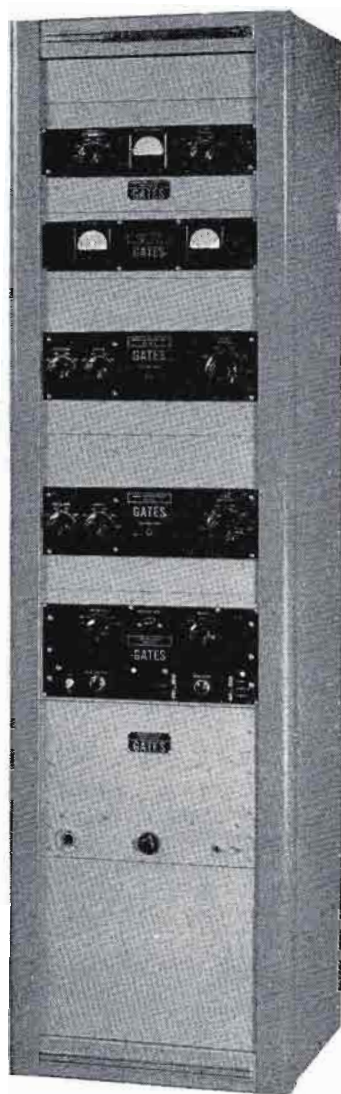
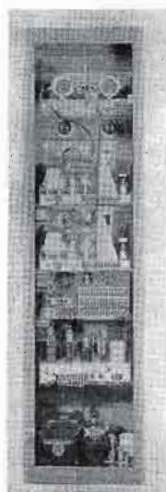

ORDERING INFORMATION

	<u>Cat. No.</u>
Two channel telephone and telegraph transmitter with one set of tubes, less crystals	M-3449Y
Spare 100 % tube complement	TK-222
Plug-in coil sets: For 2-3 Mc	M-3641
For 3-4.2 Mc	M-3642
For 4-7.2 Mc	M-3643
For 7-13 Mc	M-3644
For 12-22 Mc	M-3645
Crystal and holder for 0.02 % accuracy	H7
Crystal and holder for use in JKO-2 oven (listed below), 0.005 % accuracy	H17
Temperature controlled oven only for mounting two H17 crystals	JKO-2
Complete push-to-talk microphone assembly	M-4237

NOTE: For prices see pink price sheet in back of catalog. For full description of crystals, see Page 190. — Be sure to specify crystal frequency when ordering.

GATES

217

Single Channel Phone/CW 250 Watts Output

Perhaps the majority of radio telephone and telegraph services operate on one channel only. This transmitter provides single frequency operation on any frequency between 2-26 Mc simply by selecting the proper coil set listed at the bottom of the page and the correct crystal. By referring to the illustration at the right, the following units comprising a complete transmitter are installed and inter-wired, ready for use. Reading from top to bottom, they are:

- Single channel antenna coupling unit, M-4239
- Meter panel, M-3460Y
- Radio frequency unit, M-3452Y
- Control panel, M-3461Y
- Modulator unit, M-3453Y
- Power supply unit, M-3454Y

Equipment is mounted in a rack cabinet standing 68" high. May be used with M-4237 microphone assembly and choice of crystals for either 0.02% or 0.005% accuracy. Meets all international requirements for commercial radio telephone and telegraph operation.

SPECIFICATIONS

- FREQUENCY RANGE: 2-22 Mc by coil selection.
- FREQUENCY STABILITY: 0.005% when used with JKO-2 oven, or 0.02% when used with H7 crystal and holder.
- MODULATION: High level Class B with self-contained peak limiting amplifier and 3000 cycle cutoff filter.
- POWER OUTPUT: 250 watts telephone and telegraph.
- POWER INPUT: 115 volts, 50/60 cycles.
- AF INPUT: Hi-Z for microphone and 600 ohms for line. Push-to-talk facilities for transmitter On-Off and receiver muting provided.
- RF OUTPUT: Single channel, 20-300 ohms.



ORDERING INFORMATION

	<u>Cat. No.</u>
Single channel telephone and telegraph transmitter with one set of tubes, less crystals	M-3491Y
Spare 100% tube complement	TK-237
Plug-in coil sets: For 2-3 Mc	M-3641
For 3-4.2 Mc	M-3642
For 4-7.2 Mc	M-3643
For 7-13 Mc	M-3644
For 12-22 Mc	M-3645
Crystal and holder for 0.02% accuracy	H7
Crystal and holder for use in JKO-2 oven (listed below), 0.005% accuracy	H17
Temperature controlled oven only for mounting H17 crystals	JKO-2
Complete push-to-talk microphone assembly	M-4237

NOTE: For prices see pink price sheet in back of catalog. For full description of crystals, see Page 190. — Be sure to specify crystal frequency when ordering.

Single Channel Phone/CW 250 Watts Output

This transmitter is identical in every respect to the M-3491Y described on the preceding page, only the single channel antenna coupling unit has been eliminated. This means that the output impedance from the radio frequency unit of 50 ohms is the final output impedance of the transmitter. Should be used for any single channel telephone and telegraph operation where the antenna coupling equipment is remotely located from the transmitter and transmission of power between the transmitter and antenna coupling unit is at 50 ohms impedance.

Looking at the illustration to the right, from top to bottom, the following units are incorporated, inter-wired and ready for use:

- Blank panel
- Meter panel, M-3460Y
- Radio frequency unit, M-3452Y
- Control panel, M-3461Y
- Modulator unit, M-3453Y
- Power supply unit, M-3454Y

All equipment is mounted in a standard rack cabinet 68" high. Equipment may be used with H7 crystal and holder for 0.02% accuracy, or H17 in JKO-2 temperature controlled oven for 0.005% accuracy.

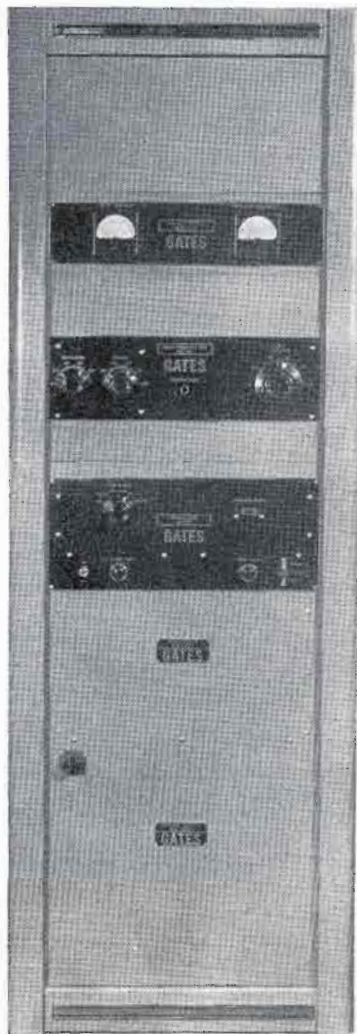

SPECIFICATIONS

- FREQUENCY RANGE:** 2-22 Mc by coil selection.
- FREQUENCY STABILITY:** 0.005 % when used with JKO-2 oven, or 0.02 % when used with H7 crystal and holder.
- MODULATION:** High level Class B with self-contained peak limiting amplifier and 3000 cycle cutoff filter.
- POWER OUTPUT:** 250 watts telephone and telegraph.
- POWER INPUT:** 115 volts, 50/60 cycles.
- AF INPUT:** Hi-Z for microphone and 600 ohms for line. Push-to-talk facilities for transmitter On-Off and receiver muting provided.
- RF OUTPUT:** Single channel, 50 ohms.

ORDERING INFORMATION

	<u>Cat. No.</u>
Single channel telephone and telegraph transmitter with tubes, less crystals	M-3680Y
Spare 100 % tube complement	TK-237
Plug-in coil sets: For 2-3 Mc	M-3641
For 3-4.2 Mc	M-3642
For 4-7.2 Mc	M-3643
For 7-13 Mc	M-3644
For 12-22 Mc	M-3645
Crystal and holder for 0.02 % accuracy	H7
Crystal and holder for use in JKO-2 oven (listed below), 0.005 % accuracy	H17
Temperature controlled oven only for mounting H17 crystals	JKO-2
Single channel antenna coupler for mounting adjacent to transmission line if antenna remote from transmitter	M-4239
Complete push-to-talk microphone assembly	M-4237

NOTE: For prices see pink price sheet in back of catalog. For full description of crystals, see Page 190. — Be sure to specify crystal frequency when ordering.



Single Channel Telegraph, 250 Watts Output

A straightforward, highly reliable, single channel telegraph transmitter that may be converted at any future time to a telephone transmitter by simply adding the M-3453Y modulator. Provides 250 watts output at keying speeds up to 60 WPM. Cathode type keying is provided and an external high speed keyer can easily be used. By referring to the illustration to the right, the following units are provided. From top to bottom:

- Blank panel
- Meter panel, M-3460Y
- Radio frequency unit, M-3452Y
- Control panel, M-3461Y
- Blank panel
- Power supply unit, M-3454Y

Unit is constructed in a standard rack cabinet 68" high. When used with H7 crystal and holder, stability is 0.02%, or when used with H17 crystal and holder in JKO-2 temperature controlled oven, frequency stability is then 0.005%.

This transmitter is provided less antenna coupling unit, however if single antenna coupling unit to match impedances of 20-300 ohms is desired, order M-4239 which can be instantly inserted in place of the topmost blank panel.

SPECIFICATIONS

- FREQUENCY RANGE: 2-22 Mc by coil selection.
- FREQUENCY STABILITY: 0.005% when used with JKO-2 oven, or 0.02% when used with H7 crystal and holder.
- POWER OUTPUT: 250 watts telegraph.
- POWER INPUT: 115 volts, 50/60 cycles.
- RF OUTPUT: Single channel, 50 ohms.



ORDERING INFORMATION

	Cat. No.
Single channel telegraph transmitter with tubes, less crystals	M-3629Y
Spare 100% tube complement	TK-238
Plug-in coil sets:	
For 2-3 Mc	M-3641
For 3-4.2 Mc	M-3642
For 4-7.2 Mc	M-3643
For 7-13 Mc	M-3644
For 12-22 Mc	M-3645
Crystal and holder for 0.02% accuracy	H7
Crystal and holder for use in JKO-2 oven (listed below), 0.005% accuracy	H17
Temperature controlled oven only for mounting H17 crystals	JKO-2
Single channel antenna coupler	M-4239

NOTE: For prices see pink price sheet in back of catalog. For full description of crystals, see Page 190. — Be sure to specify crystal frequency when ordering.

1000 Watt High Speed Telegraph Transmitter

- Specifically for police band from 2805-7935 Kc but models available for 2-22 Mc.
- High speed electronic keying.
- Multi plug-in oscillators for quick frequency change.
- Remote control as optional accessory.
- Heavy design for 24-hour, day-in and day-out service.
- Designed for ease of maintenance and servicing.

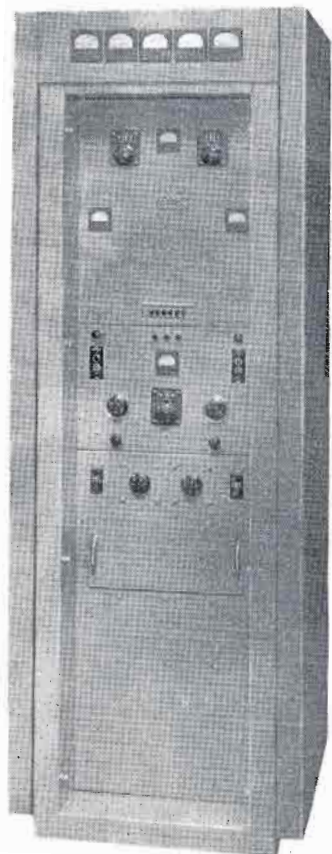

Transmitter accommodates three oscillators of plug-in type which slide into the front of the transmitter, as illustrated below. Each oscillator completely self-contained other than power supply. Provided with temperature controlled crystal holder for 0.005% accuracy. Changing oscillators is accomplished through three relays, push-button operated from transmitter control, or optional remote control.



This 1000 watt high speed telegraph transmitter is designed specifically for police service where three closely associated crystal frequencies are employed, such as 2804, 2808 and 2812—a typical police band. Its design, however, is adaptable to any frequency between 2-22 Mc, and is for use where a highly reliable, heavy duty, high speed telegraph transmitter is required.

1000 Watt High Speed Telegraph Transmitter

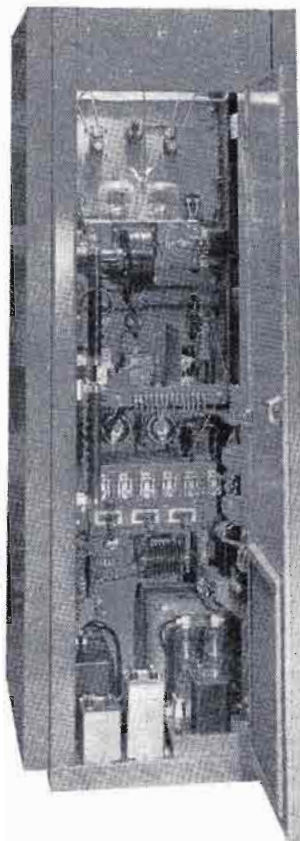

GENERAL DESIGN: Transmitter is completely constructed in one cabinet: 78" high, 28½" wide, 32" deep, with full size back door, forced air cooling of power tubes, convex cooling of transmitting plant with filtered air intake. Sides of cabinet are removable and cabinet design is such that all front panel controls are inset to prevent brushing control accidentally when walking by. Finish is in dark gloss gray for easy cleaning.

OSCILLATORS: Three provided, each having a temperature controlled oven operating from self-contained transformer of the self-tuned type, selectable into the transmitter by relays. Push-button control oscillators removed from front for either servicing or if for any reason it is desired to change frequency. Design of oscillator is for extreme accuracy and impervious to fall-out.

INTERMEDIATE AMPLIFIERS: The output of the oscillators is fed into a 6AG7 doubler stage, self-neutralized. The doubler and oscillator are electronically keyed (see keyer below). The second intermediate amplifier is a 4-65A, self-neutralized. The use of three RF stages prior to the power amplifier is complementary to a square wave form during keying. Prevents possibility of any interaction between the power amplifier and oscillator plus assuring an abundance of driving power to the final amplifier under all conditions.

POWER AMPLIFIER: Consists of two 4-400A tubes, self-neutralized and in parallel operation. Tubes are forced air cooled through a blower mounted directly to the air duct/tube socket assembly. An air pressure control switch is part of this assembly for full tube protection in case of blower failure. Output coupling provides unusually good harmonic attenuation. This is a parallel resonant tank circuit into an L section which develops a pi-network. Because of this type of circuit, the purchaser should stipulate the RF output impedance desired when ordering. A wide range of impedances from 30-300 ohms are available, though standard impedances are usually 51 or 70 ohms. Maximum carrier output is 1200 watts, which may be reduced as desired for lower carrier power.

KEYER: Electronic keying, which operates in the plate circuit of the oscillator/first IPA—doubler stage, employs the principle of bias

ing an 811A tube where with the key closed, no current is drawn. Though keying up to 100 WPM is recommended, higher speeds are not unusual. This transmitter may also be adapted to frequency shift keying and will be so supplied when stated on the order. Frequency shift keyers are listed elsewhere in this catalog (see Index).

METERING: Nine meters are standard equipment, reading all major circuits.

PROTECTIVE DEVICES: Include PA overload relay, bias under voltage relay, time delay relay, filament start relay, plate start relay, air pressure switch of diaphragm type, and all necessary interlocks.

POWER SUPPLIES: Four are supplied including main high voltage, full wave rectifier, low voltage bias supply, low voltage selenium supply for relay/remote operation.

Remote control panel for use with CMP-1, 1000 watt transmitter where transmitter is remotely controlled from a control desk either adjacent or several hundred feet distant. Mounted on standard 19"x5¼" rack panel. Includes plate On-Off switch, keying facility, pilot lights indicating filament and plate On, and push-button for selection of operating frequencies.



Individual view of one of the three plug-in oscillator units employed in the CMP-1, 1000 watt transmitter. Oscillators may be removed without disconnecting a wire and from the front of the transmitter.



1000 Watt High Speed Telegraph Transmitter

SPECIFICATIONS

FREQUENCY RANGE: Specifically designed for 2-8 Mc police frequencies but available on order for any frequency up to 22 Mc.

OSCILLATORS: Three supplied to frequency as ordered.

MAXIMUM POWER OUTPUT: 1200 watts CW.

POWER INPUT: Approximately 1900 watts.

INPUT VOLTAGE: 230 volts, 3-wire, single phase, 50/60 cycles.

KEYING: Electronic 100 WPM or less.

FREQUENCY SHIFT KEYING: Optional provision when ordered. FSK not part of transmitter (see F5 keys—Index).

SIZE: 78" high, 28½" wide, 32" deep.

FINISH: Dark gloss gray.

TUBES: Three 6AG7 oscillators, 6AG7 first IPA/doubler, 4-65A second IPA; two 4-400A power amplifiers, 811A keyer; two 800B rectifiers, 5Y3GT bias rectifiers, 5U4G low voltage rectifiers.

RF OUTPUT IMPEDANCE: As ordered and available 30-300 ohms. Recommended RF output impedances are 51 or 70 ohms.

RF STABILITY: 0.005% or better.

LOGGING: Veeder counter controls on all variable controls to one-tenth turn. Accurate dial controls on other variable units for any pre-set logging of frequency.

ORDERING INFORMATION

	<u>Cat. No.</u>
Complete transmitter for operation on 2804, 2808 and 2812 Kc, with tubes, less crystals	CMP-1
Complete transmitter for operation on 5135, 5140 and 5195 Kc, with tubes, less crystals	CMP-1A
Complete transmitter for operation on 7480, 7805 and 7935 Kc, with tubes, less crystals	CMP-1B
Complete transmitter for operation on any closely associated frequencies not stated above up to 22 Mc, with tubes, less crystals	CMP-1D
Remote control panel, rack mount	CON-2
100% spare tube complement for above transmitters	TK-138

NOTE: For pricing information see pink price list in the back of this catalog. Be sure and specify frequency of operation and transmission line impedance when ordering.

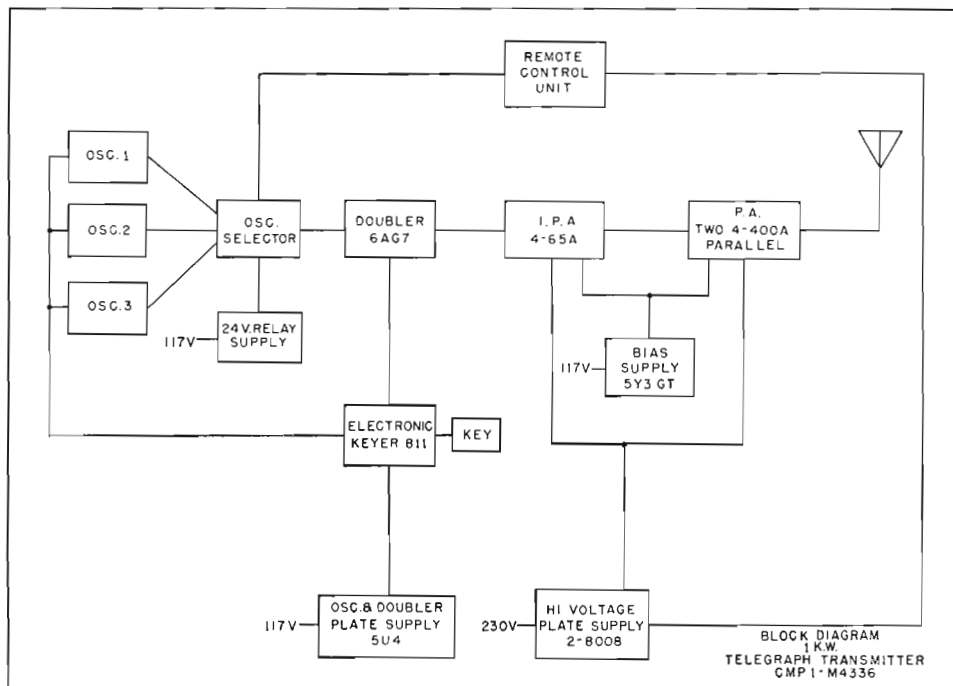

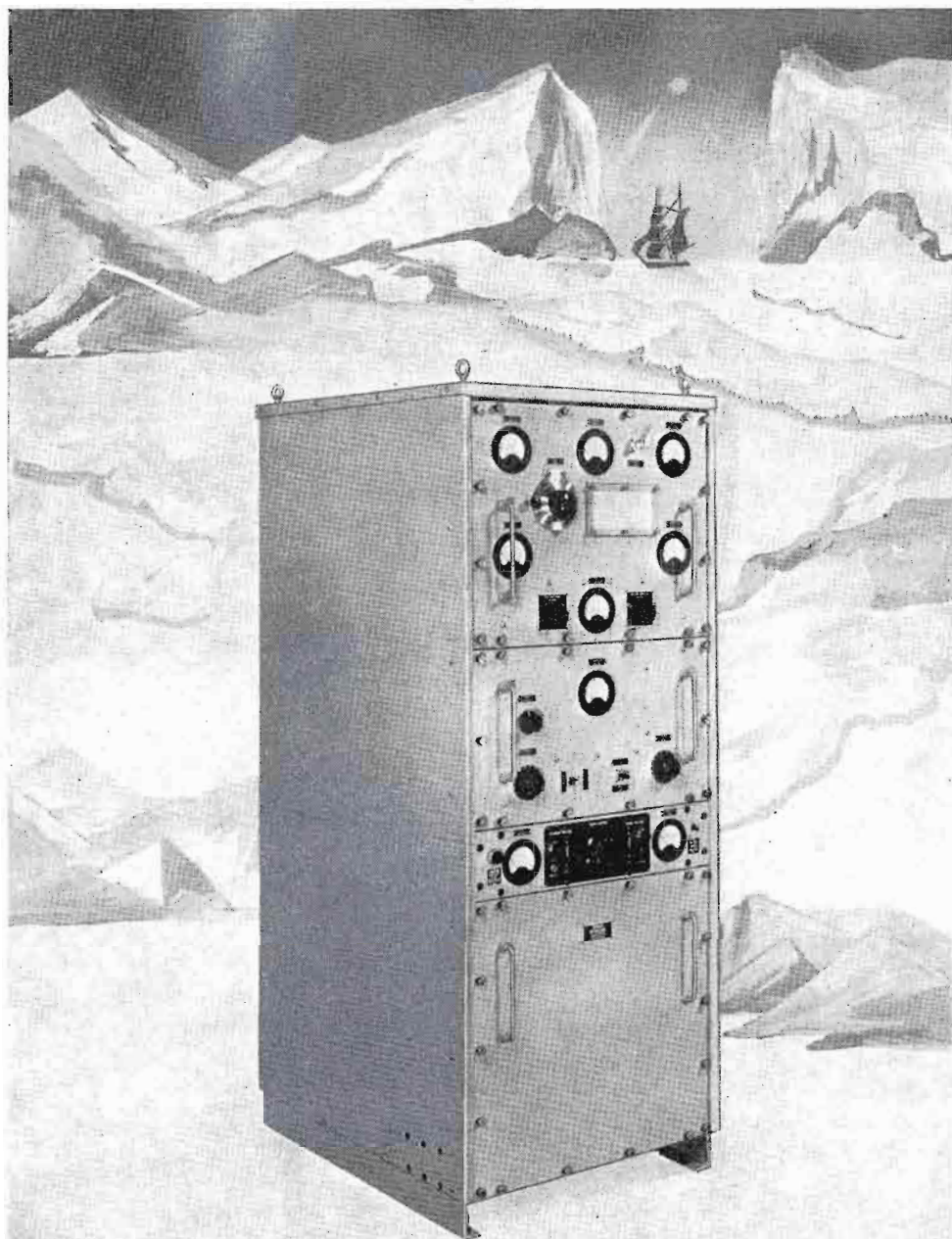

GATES Low Frequency Homing Beacon Transmitter —

Used with the Byrd Expedition to the Antarctic.

Low Frequency Homing Beacon Transmitter

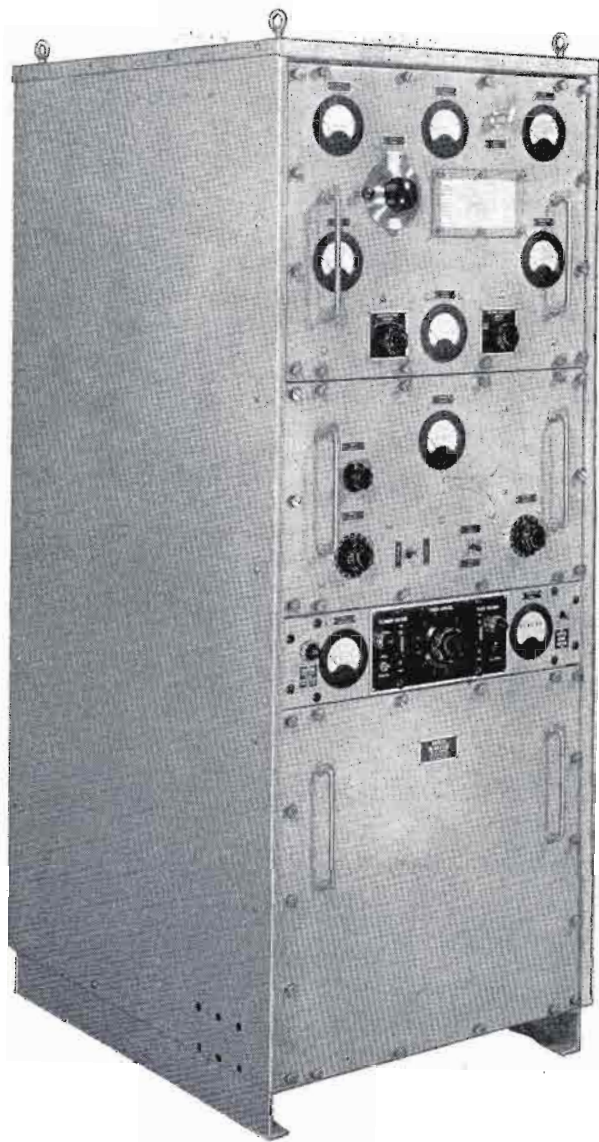

Built to JAN specifications. 400 watts maximum power output with variable front panel power selector for lower powers to 25 watts. Includes associated antenna coupler, remote control station and automatic code keyer. Frequency range, 200-800 Kc.

(continued next page)

HOMING BEACON TRANSMITTER

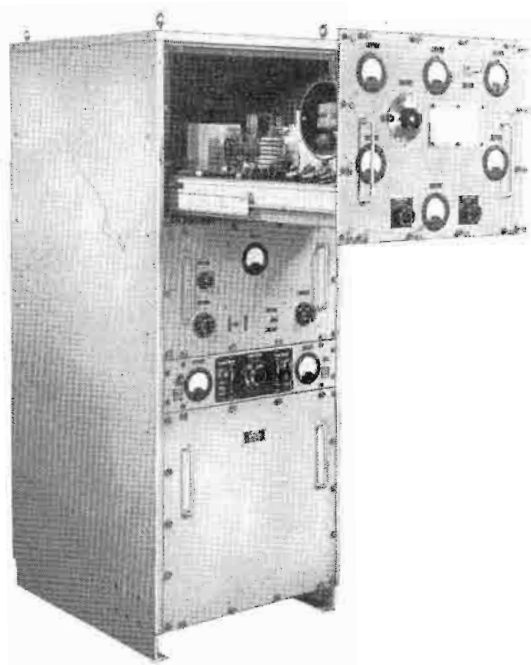

Left: Radio frequency deck slides out on roller bearing compound extension slides. Operating frequency may be quickly changed, and all parts are quickly accessible.

Right: Audio deck slides out to service. The code keyer is located here, and is instantly accessible to change keying combination as well as to reach all components.

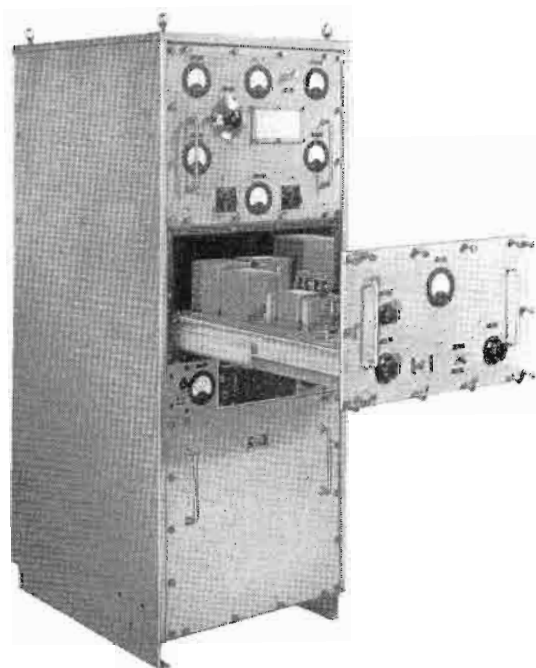

VARIABLE OUTPUT 25-400 WATTS

The Gates MO-3975 low frequency homing beacon transmitter is designed for operation at any carrier power up to 400 watts. Carrier power is adjustable down to 25 watts by means of a tapped auto transformer controlled with a heavy tap switch on front of the transmitter. Pressurized forced air cooling is provided.

High level modulation is employed, along with a complete audio system incorporating a peak limiter to prevent over-modulation, and a type 36 code keyer operating from a phase shift type audio oscillator at 1020 cycles.

General construction is to JAN specifications, in heavy steel frame to which each drawer section is secured by captive thumb screws. Design is heavy enough to stand Class B shock tests and operate in ambient temperatures between -54° C. and $+65^{\circ}$ C. — Automatic reset of the carrier provides 4 instantaneous recycling periods before turn-off. Transmitter may be reset from the switch provided on the remote control unit.

Xenon gas type high voltage rectifier tubes are employed to permit operation in extremely low ambient temperatures. — RF output is 51.5 ohms unbalanced, which may feed into coupling unit of purchaser's design or the Gates MO-4116 tuning unit which is designed to couple into T type antenna 200' on the horizontal and vertical down lead heights from 15 to 50 feet.

The remote unit consists of complete speech amplifier along with transmitter off-on switch. Amplifier is provided with decibel meter, level control and dynamic microphone of 50 ohms impedance attached to push-to-talk desk stand. — Designed either for desk or rack mount. Size $10\frac{1}{2}'' \times 19'' \times 12''$.

(continued next page)

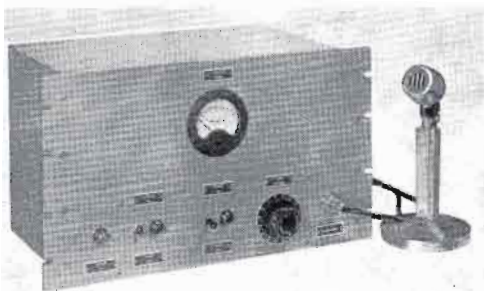

LEFT: M-4033 Remote control unit, speech amplifier and microphone assembly.

RIGHT: M-4116 Antenna coupler with front plexiglass cover removed. Operates with a 200' T antenna at all frequencies between 200-800 Kc.

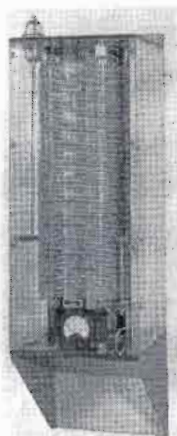

Specifications, Ordering Data, Beacon Transmitter

CARRIER POWER: Maximum, 400 watts; minimum, 25 watts.

MODULATION: Class AB 1 high level—voice, or code wheel keying at 1020 cycles.

KEYER: Type 36 code keyer 8 RPM or equal to 4/6 WPM. Code wheel has 60 segments allowing for any three-letter identification with code signal. Segments are of stainless steel and adjustable with ordinary screw driver.

CARRIER RANGE: 200 to 800 Kc.

FREQUENCY STABILITY: 0.005%.

AUDIO RESPONSE: ± 2 db 400-3000 cycles with sharp cut-off at 3000 cycles and gradual roll-off below 400 cycles for good voice quality.

NOISE: 40 db below 100% modulation at 400 watts.

DISTORTION: 6% or less 400-3000 cycles.

RF IMPEDANCE: Transmitter, 51.5 ohms. When used with M-4116 coupler, to couple to T antenna 200' long and lead in to 50'.

AUDIO IMPEDANCE: Transmitter, 600 ohms —10 db for 100% modulation at 400 watts output. Microphone input, 50 ohms.

CONTROL: Local or remote by means of 3-wire cable or 600 ohm 2-wire simplex telephone line.

POWER CONSUMPTION: 2200 watts at 115 volts, 60 cycles, single phase at full power output.

TUBES: 5670 (2C51) crystal or VF oscillator; 6AC7 first IPA, 807 second IPA, 4-400A power amplifier, PP 4-250A modulators, PP 6SJ7 audio drivers, pair 4B32 xenon gas rectifiers, pair 5U4G low voltage rectifiers, 6X5GT bias rectifier and 6L6 clamp tube. — Remote unit, three 6SJ7 and one each 5U4G, VR105.

METERING: Individual 3" meters provided for: power line voltage, elapsed time, second IPA plate, PA grid, PA plate, modulator plate and RF output. — Single multi-metering for crystal oscillator plate, first IPA plate and second IPA grid.

SIZE AND WEIGHT: Transmitter 72" high, 26" wide and 30" deep, closed. Added 24" from front to back with drawers out. — Weight packed, 1400 lbs., 60 cu. ft. Antenna coupler and speech unit not included.

Weight of remote unit, 80 lbs., 4 cu. ft.

Weight of remote antenna coupler, 120 lbs., 8 cu. ft.

FUNCTIONAL DIAGRAM—See next page.

ORDERING INFORMATION

Cat. No.

Transmitter complete with tubes and self-contained code keyer, less antenna coupler, remote control unit, crystal and oven	M-3975
Antenna coupler complete	M-4116
Remote control/audio amplifier, less microphone	M-4033
Microphone and desk stand assembly	M-4124
Crystal and oven (state frequency)	JK02H17

PRICES: See pink supplement in rear of catalog.

Beacon Transmitter --- Modulation Monitor

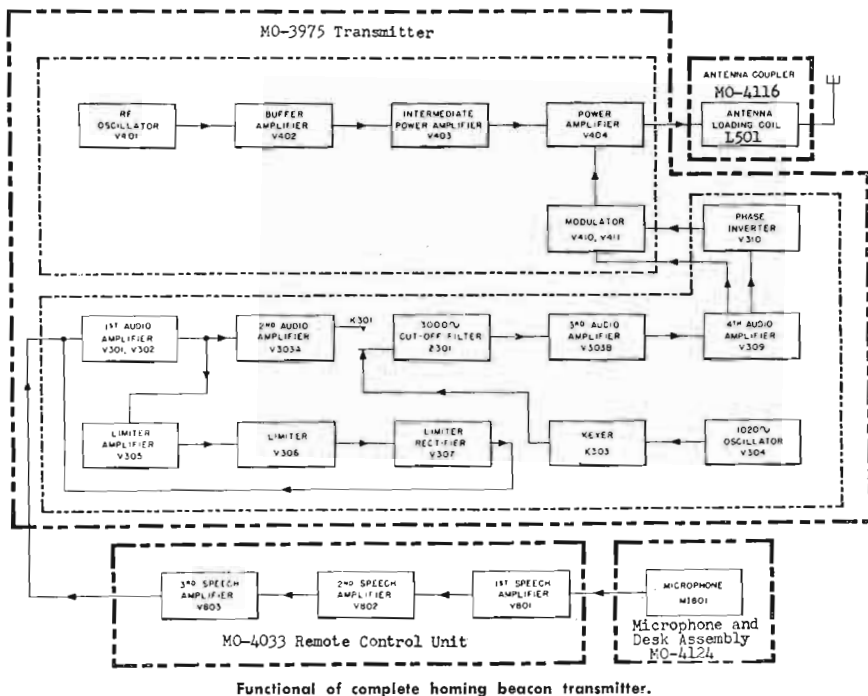

TUBELESS MODULATION MONITOR

An excellent modulation monitor for use with communications transmitters. May also be used with broadcast transmitters where regulations permit. Has no tubes. Uses Germanium crystals. Has carrier level and modulation percentage meters along with positive-negative peak checking. Panel size: 3½"x19". An unusually accurate, low cost modulation monitor that has wide application. For FCC approved modulation monitor see Page 59.

SPECIFICATIONS

MODULATION METER: Calibrated 0-110% modulation and in decibels.
CARRIER METER: When adjusted mid-scale, reads correct modulation percentage.
ACCURACY: 2% at 100% modulation.
RESPONSE: ±2 db 50-10,000 cycles.
INPUT: Approximately ¼ watt. Input voltage, 20 at 1000 Kc.
RF RANGE: 2-32 Mc.

M-3737 Modulation Monitor

\$95.00

GATES

229

35-45 Mc AM Modulated 500W (Input) Transmitter



Often a transmitter designed for a particular application has wide uses in other fields. This model, having 500 watts input and high level modulated, was designed for paging service at the specific frequencies of 35.58 Mc and 43.58 Mc. — Because of the substantial power and operation at the top end of the AM band, it will find many other uses as well. — On special order, operation on any single frequency lower than 45 Mc is easily possible.

Transmitter is equipped with the M-5263A limiter/filter amplifier, described on Page 233. This permits full modulation without over-modulation and also develops voice crispness by reason of the 200-2500 cycle response.

Standing 78" high, 23½" wide and 21" deep, a minimum floor space is required for a transmitter of this power. Ventilation is through an air intake fan at the base of the back door. — Metering is complete and the transmitter meets FCC requirements for paging service. — A front door closes over the main tuning controls to prevent tampering and door may be locked. — Finish is in medium gloss gray.

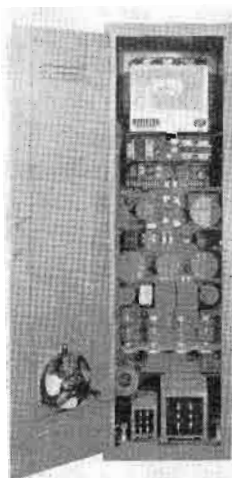

M-5245 High Frequency Transmitter



M-5272 Control Console

Designed to operate with the M-5245 transmitter where transmitter is separate from control point. By using this console the transmitter may be a few rooms away or as much as 20 miles. Only a single pair telephone line required, as remote control is simplex on same line as voice signal. Transmitter may be turned on and off, and complete control is possible through the use of this equipment. — The M-5272 console is optional equipment. Specifications on next page.

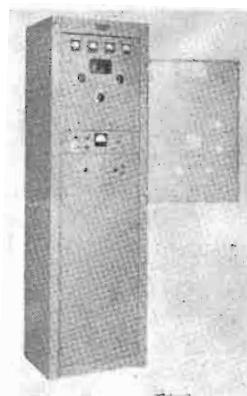

Front protective door will lock closed to prevent detuning. Often equipment of this kind is operated near the curious. This then becomes a good feature.

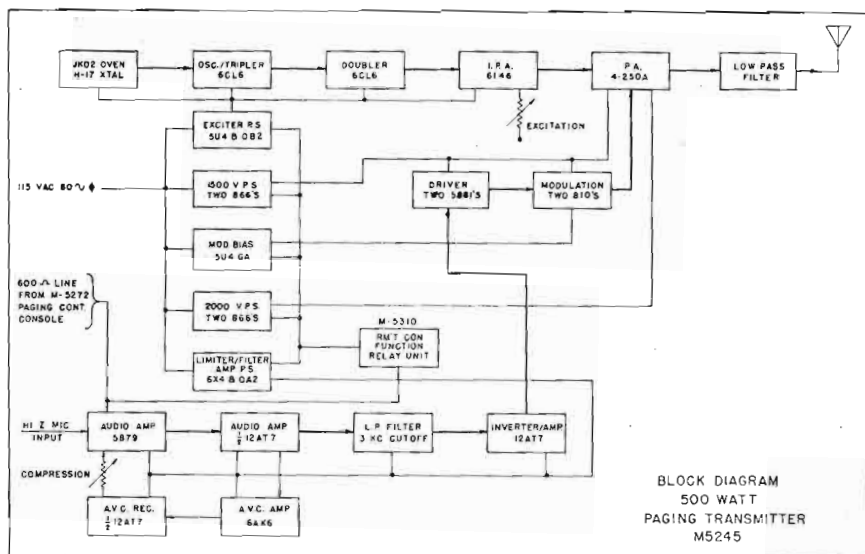

B-13535

Specifications M-5245 High Frequency Transmitter

RATED POWER INPUT: 500 watts (efficiency 70% or better).

CARRIER FREQUENCY: 35-45 Mc as ordered. Lower frequencies on special order.

STABILITY: $\pm 0.01\%$.

FREQUENCY MULTIPLICATION FACTOR: 6.

MODULATION: Class B high level.

AUDIO RESPONSE: 200-2500 cycles with sharp cut-off above 3000 cps.

AUDIO INPUT: 600 ohms at 0 dbm. Hi-Z at -55 db ± 5 db.

RF IMPEDANCE: 51 ohms.

HARMONIC SUPPRESSION: Low pass filter for specific frequencies between 35-45 Mc.

POWER INPUT: 115 volts, 50/60 cycles. 2185 VA at 100% mod. 1725 VA idling.

TUBES: (4) 806A rectifiers, (2) 810 modulators, 5881 audio drivers, 12AT7 audio amplifiers, (1) 4-250A power amp., 6AK6 audio, 5879 audio, OA2 regulator, 6X4 rectifier, 6146-IPA, 6CL6 osc., 5U4G rectifier, 5U4GA bias rectifier.

PROTECTIVE DEVICES: Time delay relay, PA overload relay, modulation overload relay, PA underload relay, PA air interlock control, rear door personnel door interlock.

AUDIO RESPONSE: ± 3 db 200-2500 cycles.

DISTORTION: 8% or less at 95% modulation.

NOISE: 40 db or better below 100% modulation.

SIZE: 78" high, 23 $\frac{1}{2}$ " wide, 21" deep. Rear door swing, 21".

WEIGHT (packed): 632 lbs. Cubage, 41 $\frac{1}{2}$.

Specifications M-5272 Control Console

GAIN: 76 db ± 2 db from mic input to line output.

RESPONSE: $\pm 1\frac{1}{2}$ db 30-15,000 cycles.

DISTORTION: 1% or less, 50-15,000 cycles at +8 VU output.

NOISE: 60 db or better below +8 VU output with -60 db input.

IMPEDANCES: (input 30/50 or 150/250 ohms. (output) 600 ohms CT for Simplex feed.

METER: 4" illuminated VU.

CONTROLS: Audio gain, transmitter filament and plate on-off, mic on, line on and tape on.

M-5310 RELAY UNIT: Self-contained for remote control operation of M-5245 transmitter up to 20 miles—single pair telephone line.

TUBES: 6J7, 6SJ7, 6SN7, 6X5GT, OC3/VR105.

SIZE: 19 $\frac{1}{4}$ " wide, 7 $\frac{1}{2}$ " high, 15" deep. Net weight, 29 $\frac{1}{2}$ lbs. Packed weight, 40 lbs. Cubage, 4.

ORDERING INFORMATION

Cat. No.

Transmitter complete with tubes, less crystal and oven	M-5245
100% spare tube complement for M-5245 transmitter	TK-232
Control console with tubes	M-5272
100% spare tube complement for M-5272 console	TK-257
Crystal and oven (state carrier frequency)	JK02H17

PRICES: See pink supplement in back of catalog.

COMMUNICATIONS --- Limiter/Filter Amplifier



Designed to provide microphone and line input to any communications transmitter. Embodies both limiting amplifier and high frequency cut-off filter to meet present FCC specifications. Ideal for use with new transmitters or existing communications transmitters in modernizing them to meet current FCC requirements by reducing high frequency response above 3000 cycles, and providing a fast acting limiting amplifier to prevent over-modulation of the transmitter.

Provides input circuits for either a high impedance microphone or 600 ohm line—switchable from front panel. Gain controls are provided for adjusting level of: (a) input line, (b) master gain and microphone level, and (c) input level to transmitter. A 3" meter is provided to indicate compression point.

Available in two types. M5263 has a maximum output of +18 dbm at 600 ohms. M-5263A has a maximum output of 75 volts RMS for push-pull 100,000 ohm grids. Both models have self-contained power supply.

SPECIFICATIONS

INPUT IMPEDANCES: Mic. Hi-Z. Line 600 ohms.

OUTPUT IMPEDANCES: M5263, 600 ohms. M5263A, 100,000 ohms.

GAIN: M5263, from line to output 56 db, from mic to output 86 db ± 3 db.

M5263A, line to output 42.5 db, mic. to output 72 db ± 3 db.

COMPRESSION: (Min. threshold) mic. -63 db ± 3 db. Line -33 db ± 3 db.

NOISE: 45 db or better below +18 dbm output. Measured with input of -55 dbm and 5 db compression.

DISTORTION: At compression levels up to +20 db does not exceed 5%.

At compression levels up to 30 db does not exceed 10%.

FREQUENCY RESPONSE: With high frequency filter insert at all times, essentially flat

at 200-2500 cycles. Down 10 db at 100 and 3300 cycles.

Down 20 db at 60 and 4000 cycles. Down 30 db at 35 and

4000 cycles. Down 40 db at 20 and 4800 cycles.

POWER: 115 volts, 50/60 cycles, approximately 40 watts.

TUBES: One each, 6X4, 6AK6, 5879, OA2; two each, 12AT7.

ORDERING INFORMATION

Model M5263 Communications Amplifier, with tubes	\$210.00
Model M5263A Communications Amplifier, with tubes	210.00
TK-235 100% spare tube kit	7.60

GATES

233

SELECTIVE (Heterodyne Filter) AMPLIFIER



Where receiving high frequency signals, the heterodyning of closely associated incoming signals, or two receivers beating at an audio rate, causes receiving difficulties which can often be either greatly improved or completely corrected by the use of the M3922 selective amplifier. Where the interference tone remains constant, the elimination of any single audio frequency between 20-20,000 cycles is possible. If several interference tones are present, selective amplifiers may be placed in series and each undesirable tone reduced or eliminated so that readability of the received signal is greatly improved.

Basic principle is that of a selective audio filter, usually attached ahead of the audio system in the receiver or where attached to the 600 ohm output, a fixed pad should be inserted to provide proper input level. An additional amplifier is required in the latter case to provide loudspeaker level. Interference tone rejection coverage between 20-20,000 cycles is by means of a calibrated switch plus coarse and fine adjustments. Audio level control, pilot light, fuse and starting switch complete the front panel facilities.

SPECIFICATIONS

INPUT IMPEDANCE: 600 ohms.
INPUT LEVEL: Approximately 0 VU.
FREQUENCY RESPONSE: ± 1 db 20-20,000 cycles.
DISTORTION: $1\frac{1}{2}$ % or less 20-20,000 cycles at +18 dbm.
NOISE: 70 db or better below +18 dbm.
REJECTION: 40 db up at 220 cycles and 50 db up at 220-20,000 cycles.

TUBES: Four 6SN7, three 6SJ7, one each OC3, OD3 and 5Y3GT.
SIZE: 19" wide, $5\frac{1}{4}$ " high, $16\frac{1}{2}$ " deep.
POWER: 115 volts, 50/60 cycles at approximately 60 watts.
SHIPPING WEIGHT: 35 lbs.

ORDERING DATA

M-3922 Selective Amplifier
with tubes\$220.00

M-4138 spare 100%
tube complement 5.40

Where customer requirements exceed 25 units, write for special quantity prices.

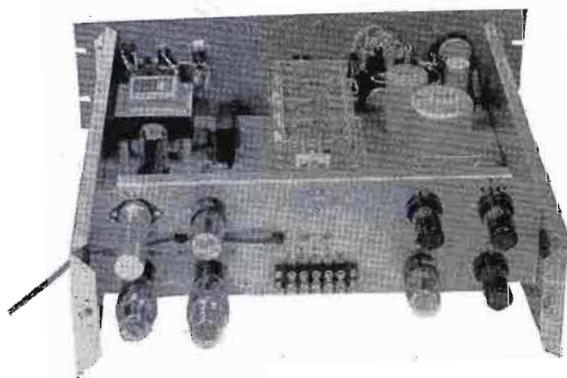

TOTALIZING RECORDER



Gates MO-3815 Totalizer is a precision unit used to record the time a signal is at or above a pre-selected value. It is widely used for measuring the field intensity of high frequency signals in propagation tests. It is designed for extreme accuracy and stability over long periods of time. The most discriminating customers have found nothing lacking in its performance.

Used with a high quality receiver and fed off the rectified output. The input voltage range of the Totalizer is 0 to —10 volts DC. Any of the ten channels may be set to any voltage within this range. The sensitivity of the Totalizer is guaranteed to be within .05 volts DC input, however average readings are from .002 to .005 volts. This sensitivity is the difference in the voltage required to energize the channel and to de-energize it. Thus, a channel may be set up to energize with nine volts input and will de-energize when the signal drops to 8.998 volts. The isolation between any or all of the ten channels is great enough to permit setting them up in an increasing sequence of .05 volts apart, yet no interaction of channels will occur.

Each channel, when energized, starts a synchronous one RPM motor that drives a Veeder-Root counter. The counter reads in tenths of minutes and will total up to 9,999.9 minutes. A front panel reset wheel allows resetting from any reading to zero with one revolution of the wheel. The control unit and the counter unit are separate.

CONSTRUCTION: Totalizer recorder: 14"x19" cast aluminum panel and shelf with drop down front door for component servicing. Finish, gray.

Counter panel: 5 1/4"x19". Finish, gray.

TUBES: Eleven 6SL7, ten 6SJ7, one each 6Y6G, 6SN7GT, OD3.

RELAYS: Hermetically sealed.

POWER: 115 volts, 60 cycles, approximately 200 watts.

EQUIPMENT SUPPLIED: Totalizing recorder amplifier, totalizing counter panel, 10' interconnecting cable, 100% set tubes.

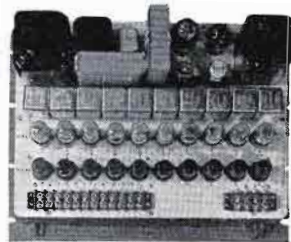

M-3815 Totalizing Recorders \$1,375.00
 TK-230 100% spare set of tubes 29.15

GATES

235

FREQUENCY SHIFT CONVERTER



Employed in the operation of a single or dual diversity receiving system for teletypewriters. Frequency shift receiving system usually operates from two diversity receivers to convert Mark and Space tones into direct current pulses capable of operating teletypewriter, tape recorder or similar device. Converter may also be used for reception of make or break CW signals.

In basic operation for each channel the received audio tones are limited, amplified, discriminated and rectified. Channels are then diversity combined and the result is fed into push-pull DC amplifiers with the output either polar or neutral as desired. Features include excellent ease of operation. Dual limiter tubes providing 50-60 db limitation of each channel, 2-inch oscilloscope to permit tuning the receiver and converter for best performance. Tone amplification after discrimination permits high level discriminator rectifier output with corresponding improvements in signal-to-noise performance. The high level DC pulse signals are limited so that drift or variations of shift of incoming signal can be tolerated to a considerable degree. Manufactured by Northern Radio.

SPECIFICATIONS

INPUT IMPEDANCE: 600 ohms.

INPUT LEVEL: -20 to +30 VU.

INPUT FREQUENCY SHIFT LIMITS: 100-1000 cps.

OUTPUT: (1) Neutral DC pulses of 60 MA in 1800 ohm load; (2) Polar DC pulses ± 30 MA in 1800 ohm load; (3) Operation into any impedance 100-100,000 ohms.

KEYING SPEED: 600 WPM.

CONTROLS: Switches, Primary, Sense, Monitoring, Channel 1, Channel 2, Polar-Neutral, Monitor intensity, monitor focus, discriminator tuning, output current, monitor centering.

TUBES: Four each 6H6GT, 5W4; two each 6SN7, 6SL7GT, 6SL7, 6L6; one each 2AP1-A, 6H6.

SIZE: 19" wide, 7" high, 15" deep.

SHIPPING WEIGHT: 70 lbs.

CUBAGE: 5.

ORDERING INFORMATION

Model 107-2 Frequency Shift Converter with tubes\$705.00
TK-145 spare 100% tube complement 28.67

FREQUENCY AND SHIFT MONITOR

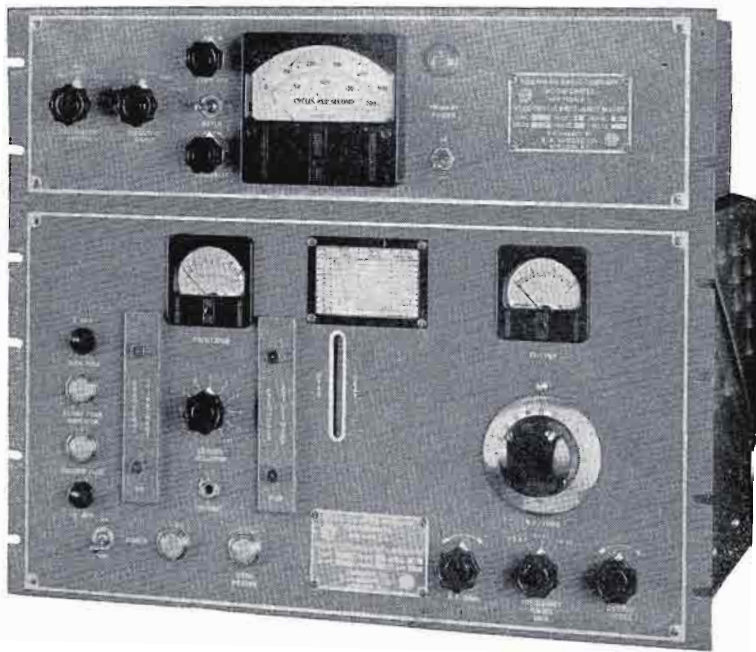

A monitoring device to provide a secondary standard in measuring frequency of transmitters in the 2.5—30 Mc range. Also measures frequency shift of Mark and Space signal either for setup or during keying cycle. Designed around a highly stable crystal oscillator and buffer stage and with provision to select any of ten crystals or an external oscillator. Wide band amplifiers develop output suitable for driving a harmonic generator.

As many as ten separate transmitters may be monitored for both frequency and frequency shift. Where crystal frequencies are halfway between Mark and Space frequencies, the carrier may be monitored when keying. This is extremely useful in low speed operation such as teleprinter. For high speed keying, monitoring is through headphones and by adjusting for steady tone. Manufactured by Northern Radio.

SPECIFICATIONS

FREQUENCY RANGE: 2.5-30 Mc in three ranges: 2.5-5.7 Mc, 5.7-13 Mc and 13-30 Mc. Crystal oven accommodates 10 crystals. Input connection for external oscillator provided.
FREQUENCY STABILITY: 2 cps per Mc with power line variations between 105-130 volts.
FREQUENCY SHIFT RANGE: 10-10,000 cps.
RF INPUT IMPEDANCE: 50 or 470,000 ohms.
RF INPUT LEVEL: 100 MV or less.
AUDIO OUTPUT LEVEL: 10 volts or less at 10,000 ohm impedance.
POWER: 115/230 volts, 50/60 cycles at approximately 230 watts.
CONTROLS: Switches, Primary, Frequency Range, Crystal Selector, all with adjacent pilot lights. RF tune, output level, RF gain.
TUBES: Two 6AU6, 6AQ5, 6AH6; one 65N7, 6AL5, OB2, 5Y3GT.
SIZE: 19" wide, 10½" high, 14" deep.
SHIPPING WEIGHT: 80 lbs. packed.
CUBAGE: 5.

ORDERING INFORMATION

Model 106-4A Frequency and Shift Monitor with tubes \$895.00
TK-142 spare 100% tube complement 11.85

GATES

237

FREQUENCY SHIFT KEYER



Consists of a very high stability radio frequency oscillator which provides a means of shifting a radio frequency carrier in accordance with intelligence. Replaces the crystal oscillator in the transmitter and produces "Mark" and "Space" carrier shift for transmission of teleprinter, telegraph signals or a linear carrier shift for transmission of FM telephone, facsimile or telephoto.

Consists of five main sections: (1) keying circuit; (2) reactance tube; (3) shifted oscillator; (4) crystal oscillator; (5) modulator/power amplifier.

Attention has been given to stability through an unusually accurate oscillator. Outstanding features include frequency shift dial that adjusts Mark and Space frequencies equally above and below carrier position, simplified frequency setting developing only upper sideband indication over most of the tuning range, direct reading frequency calibration of shift from 0-1000 cycles, direct reading frequency calibration of mixer and output tuning indicators from 2.5-6.7 Mc and direct reading calibration of output frequency vernier ± 600 cps. Manufactured by Northern Radio.

SPECIFICATIONS

FREQUENCY RANGE: 2.5-6.7 Mc. NOTE: Available on special order, 1.75-4.5 Mc.
OUTPUT POWER: 3 watts.
OUTPUT IMPEDANCE: 50-75 ohms.
KEYING SPEED: 150 dot cycles per second.
KEYING SIGNAL: 0 volts (Space) and +15 to +150 volts (Mark).
STABILITY: 10 cycles for ambient range 0° to +50° C. (Mark and Space frequencies).
25 cycles for line voltage variations up to 10%.
POWER: 115/230 volts, 50/60 cycles, approximately 270 watts.
TUBES: Four 6SN7; two 6SA7; one each 2E26, 5U4G, 6X5GT, OC3, OA3.
METERING: PA plate current and oven thermometer.
SIZE: Including power supply (both units), 19" wide, 15 3/4" high, 11" deep.
SHIPPING WEIGHT: 88 lbs.
CUBAGE: 5.

ORDERING INFORMATION

Model 105-4 Frequency Shift Keyer with tubes	\$790.00
TK-141 100% spare tube complement	14.20

MASTER OSCILLATORS

VFO /Crystal Oscillator-Amplifier

- 540-1600 Kc operation.
- Excellent stability as VFO.
- 10 cycle crystal accuracy.
- 2 watts RF output.

Where rapid change of broadcasting frequencies is required such as in mobile broadcasting, jamming or laboratory service, Gates has designed the M-4230 combination VFO and crystal oscillator with intermediate amplifier to provide 2 watts output. VFO reactively controlled, employing a 6V6 oscillator with VR75 regulator. Negative coefficient capacitors and careful design throughout greatly reduce effect of temperature changes. Output from 500-1100 Kc is at fundamental frequencies. Above this the output is by doubling the fundamental. VFO dial permits logging to 1 part in 5000. IPA employs 807 amplifier to 70 ohms impedance.



SPECIFICATIONS

RF OUTPUT: 540-1600 Kc at 2 watts, 70 ohms.
 CALIBRATION: 10 Kc steps. Dial 1-5000. Dial division, 200 cycles/div. straight line.
 TEMP. COEFFICIENT: 0.0005% degree F.
 STABILIZING TIME: VFO 120 min. crystal 30 min.
 ACCURACY: VFO ± 200 cycles under normal operating conditions. Crystal 10 cycles.
 TUBES: 6V6, 807, VR75.
 POWER REQUIRED: 6.3 volts 1.5A; 6.3 volts 1.4A; 350V DC at 60 MA.
 SIZE: 19" wide, 10½" high, 6½" deep.
 Weight, 24 lbs.

M-4230 VFO/Crystal Oscillator-Amplifier...\$950.00
 JK57 Crystal and Oven 50.00



SPECIFICATIONS

OUTPUT: 2-32 Mc at 75 ohms, 2 watts to 4 Mc, ½ watt to 32 Mc.
 CRYSTAL FREQUENCIES: 3 provided.
 State frequencies when ordering.
 TUBES: (4) 6AQ5, (3) 6C4, (2) 12AU7, (1) OA2, 5Y3GT.
 STABILITY: ± 20 cps 1 Mc, ambient change ± 25 from 0-50 degrees Cent. any 8 hour period.
 SIZE: 19" wide, 10½" high, 14" deep.

High Frequency Master Oscillator

A precision unit for 2-32 Mc. Also accommodates crystal oscillator. Has self-contained 100 Kc crystal for spot calibration of oscillator. Basic operation is at 2-4 Mc with multipliers providing output to 32 Mc. Calibration curves provided. Made by Northern Radio.

Cat. 115-7 Variable Oscillator.....\$980.00
 TK-144 Spare 100% Tube Set 11.80

GATES

239

NATIONAL RADIO RECEIVERS



Approved by Civil Defense under Specs. R12 and R14. The SCR-3B has a wide reputation in airline ground stations, police, general communications and wherever a top quality fixed frequency receiver is required.

Model SCR-3B

A crystal controlled, superheterodyne receiver, rack mounting (5 1/4"x19") designed to operate at any fixed frequency between 50-430 Kc and 480-40,000 Kc. Two TRF stages insure low signal-to-noise ratio. Includes carrier operated noise suppression, AVC, pre-tuned RF circuits and crystal controlled oscillator. For CW a special low drift regulated oscillator is employed. Sensitivity exceeds 6 db from 1.8-25 Mc and over 12 db for CW. Output, 3 watts into either 8 or 500 ohms. Supplied with choice of one set of coils as listed below. State operating frequency when ordering.

Model SCR-3B Receiver with tubes, one set of coils	\$385.75
Coil set: (A) 1.8-3.6 Mc, (B) 3.6-7.5 Mc, (C) 7.5-14.5 Mc, (D) 14.5-25 Mc, each	39.30
Crystal (state frequency)	17.85

National HRO-60

Recognized as one of the truly fine receivers made today. Dual conversion on all frequencies above 7 Mc. 12 permeability-tuned circuits, current regulated heaters in oscillator and mixer. HF oscillator and 5 meter amplifiers are voltage regulated. Range, 50-430 Kc, 480 Kc-35 Mc, 50-54 Mc. Size: (table model) 19 3/4" wide, 10 1/8" high, 16 1/2" deep. [rack model] 19" wide, 10 1/2" high, 17 1/2" deep. Has Hi-Fi audio system 50-15,000 cps.

HRO-60R for 1.7-30 Mc operation (rack mount)	\$533.50
HRO-60T same as above (table mount)	533.50
HRO-60RS rack mount companion loudspeaker	26.00
HRO-60TS table mount companion speaker	16.00
Coil sets to cover other ranges of (a) 25-35 Mc, (b) 50-54 Mc, each	27.50



National NC-183D

Incorporates every feature you want in a truly modern receiver. Dual conversion on 3 highest ranges. Steep sided skirt selectivity with 3 IF stages (16 tuned circuits on the high bands) plus a new crystal filter. 12 tuned circuits all other bands. 1 MV sensitivity at 6 meters. New direct lighted lucite dial. Bi-metallic temperature compensated tuning condenser. Output, 8 watts into 8 or 500 ohms. Size 19 3/4" wide, 10 1/4" high, 16 3/4" deep. Range, 540 Kc-31 Mc and 47-55 Mc.

183DR Receiver, rack mount	\$426.50
183DT Receiver, table mount	399.50
183TS Speaker, table mount	16.00
183DRS Speaker, rack mount	26.00



National NC-98

A fine receiver in the modest priced field. Frequency range, 540 Kc-40 Mc. Five band spreads in the amateur band. Has one RF and two IF stages for excellent signal-to-noise ratio. Selectivity is 11 Kc at 20 db down. Output, 1 1/2 watts at 3 ohms. Controls include: main tuning, band spread tuning, band selector, sensitivity, volume, receiver/standby switch, tone control, cue pitch, antenna trimmer, AM/CW switch, selectivity, phasing and off/on switch. Size: 16 1/2" wide, 8 3/4" high, 10 1/2" deep.

NC-98 Receiver complete	\$149.95
NC-98TS Matching Loudspeaker	11.00

HALLICRAFTERS RADIO RECEIVERS

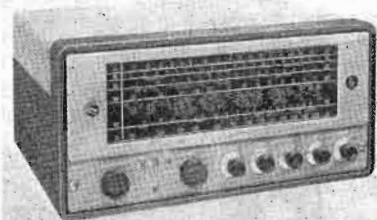

Model SX62A

For all wave service. Handles AM/CW from 550 Kc to 32 Mc and FM from 27 Mc to 109 Mc. Wide vision dial. 500 Kc crystal calibrated oscillator. 10 watt audio 50-15,000 cycles with 8 and 500 ohms out. ut. Six position band change mechanism. Antenna input, 52 or 600 ohms. Includes automatic noise limiter, two RF stages, three IF stages and AVC. For 115 volts, 50/60 cycles. Size: 20" wide, 10½" high, 16" deep.

Model SX62A Receiver \$349.95

Model SX96

Double conversion selectable sideband receiver. Range, 538-1580 Kc, 1720 Kc—34 Mc. Receives AM, CW, SSB. Selectable sideband reception of both suppressed carrier and full carrier transmissions by front panel switch. Delay AVC. Antenna input, 52 and 600 ohms. Output, 1½ watts at 3 or 500 ohms. Has carrier level meter indication. Size: 18¾" wide, 8½" high, 10½" deep. For 115 volts, 50/60 cycles. A wonderful communications receiver.

Model SX96 Receiver \$249.95



Model SX99

A fine, modestly priced receiver covering the bands from 540-1680 Kc and 1680 Kc—34 Mc. Ganged rotary switch band change. Controls: antenna tuning, sensitivity, band change, main tuning, band spread, volume, tone, standby, selectivity, crystal phasing and noise limiter. Antenna input, 52 and 600 ohms. Output, 2 watts at 3 and 500 ohms. For 115 volts, 50/60 cycles. Size: 18¾" wide, 8½" high, 11" deep.

Model SX99 Receiver \$149.95

Model S85

In the near \$100 class, here is a superb communications receiver. Range, 540 Kc to 34 Mc. Controls: sensitivity, band selector, tuning, band spread, volume, AVC, noise limiter, AM/CW, on/off, tone, pitch, standby/receive. Antenna input, 52 and 600 ohms. Output, 2 watts at 3 ohms. Size: 18½" wide, 8½" high, 10" deep. For 115 volts, 50/60 cycles. Has 7 tubes plus rectifier.

Model S85 Receiver \$119.95



Model S53A

A 7 tube, plus rectifier, receiver covering 540-1630 Kc, 2.5 Kc—31 Mc and 48-54.5 Mc. 5" built-in loudspeaker. Temperature compensated to reduce drift. 5-position band change switch. Antenna input, 300 ohms. For 115 volts, 50/60 cycles. Size: 13" wide, 7" high, 7¼" deep.

Model S53A Receiver
\$89.95



Models S94, S95 for FM

Two models designed to cover the FM communications bands of 30-50 Mc and 152-173 Mc. Has super sensitivity, inbuilt 5" speaker, headset jack, 300 ohm antenna matching, sensitivity under 1½ MV and two IF stages. 8 tubes plus rectifier. Size: 12¾" wide, 7" high, 7¼" deep. For 115 volts, 50/60 cycles AC/DC. S94 for 30-50 Mc. S95 for 152-173 Mc.

S94 Receiver \$59.95
S95 Receiver 59.95

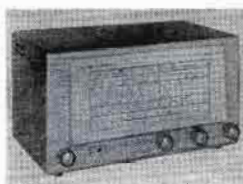

Model S38D

A low priced, yet fine performing communications receiver. Covers 540-1650 Kc and 1650 Kc—32 Mc. 4 tubes plus rectifier. Large, easy to read dial, inbuilt 5" speaker. Controls: tuning, standby, volume, AM/CW, band selector, off/on. For 115 volts, 50/60 cycles AC/DC and 220 volt operation with 87D1566 line cord.

S38D Receiver \$49.95
87D1566 Line Cord 2.00

ELECTRIC GENERATING PLANTS

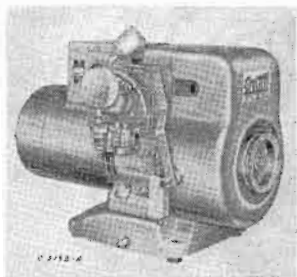

Model 1AJ

1000 watts at choice of 115 or 230 volts AC, 60 cycles. Four cycle air cooled engine. Generator directly connected to engine. Includes fuel tank, muffler, rubber vibration dampers and starting rope (manual models). Remote control starting models also include mounted control box and battery cables. Generator is 4-pole revolving armature, self-excited and drip proof. Fuel consumption approximately 0.3 gal. per KW hour full load. Size: 22" long, 19 1/2" high, 14" wide.

1AJ-1M Manual start 115V, 60 cycles, 1000 watts ...	\$399.00
1AJ-2M Same as above but for 230 volts	399.00
1AJ-1R Remote start 115V, 60 cycles, 1000 watts	429.00
1AJ-2R Same as 1AJ-1R but for 230 volts	429.00

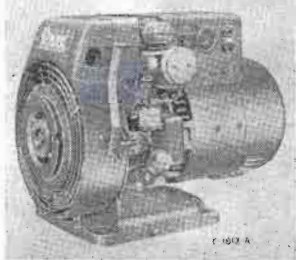

Model 2LK

2000 watts at choice of 115 or 230 volt AC, 60 cycles. Four cycle air cooled engine. Generator directly connected to engine. Includes fuel tank, muffler, rubber vibration dampers and starting rope (manual model). Remote control starting models also include mounted control box and battery cables. Generator is 4-pole revolving armature, self-excited and drip proof. Fuel consumption 0.21 gal. per KW hour full load. Size: 28" long, 16" wide, 19 1/8" high.

2LK-1M Manual start 115V, 60 cycles, 2000 watts ...	\$529.00
2LK-2M Same as above only 230V	529.00
2LK-3M Same as above only 115/230V	549.00
2LK-1R Remote start 115V, 60 cycles, 2000 watts	569.00
2LK-2R Same as above only 230V	569.00
2LK-3R Same as above only 115/230V	589.00

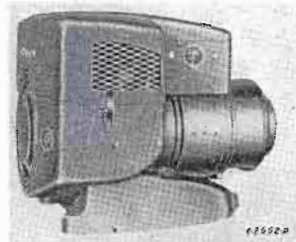

Model 305CK

3500 watts at choice of 115 or 230 volts, 60 cycles. Four cycle air cooled engine. Generator directly connected to engine. Manual start models include 4 1/2 gal. fuel tank, muffler, outlet box and starting rope. Remote starting models also include battery cables, charge rate meter and automatic charge regulator for starting battery. Fuel consumption, 0.195 gal. per KW hour full load. Size: 25 1/4" long, 20 1/2" high, 20 7/8" wide.

305CK-1M Manual start 115V, 60 cycles, 3500 watts ...	\$665.00
305CK-2M Same as above but 230V	665.00
305CK-3M Same as above but 115/230V	685.00
305CK-1R Remote start 115V, 60 cycles, 3500 watts	725.00
305CK-2R Same as above but for 230V	725.00
305CK-3R Same as above but for 115/230V	745.00

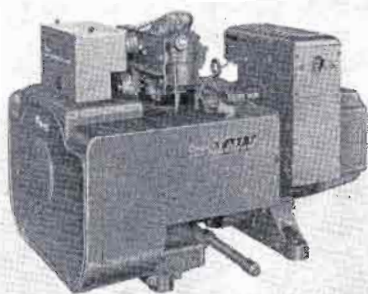

5000 Watts

Available in several voltages as listed below. Four cycle air cooled opposed cylinder engine direct driven to 4-pole self-excited generator. Holds voltage to $\pm 5\%$ and frequency to 3 cycles. Generator vacuum cooled by engine blower, all models include: muffler, handcrank, vibration dampers and 5 gal. fuel tank. Remote models also include: electric choke, battery cables, ammeter and charge regulator. Size: 37" long, 25" wide, 28" high. Fuel consumption, 0.236 gal. per KW hour full load.

5CW-3M Manual start 115/230V, 60 cycles, 5000 watts	\$ 995.00
5CK-5M Same as above but 230V	1045.00
5CW-3R Remote start 115/230V, 60 cycles, 5000 watts	1095.00
5CW-5R Remote start, 230V	1145.00

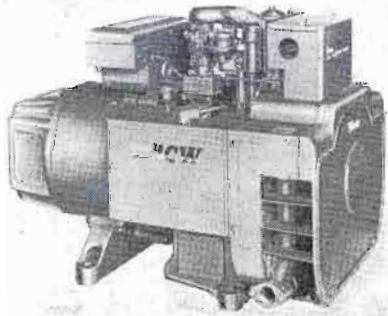

10,000 Watts

This model is very popular. Will operate a 1000 watt broadcast transmitter with tower lights and speech equipment with enough power for building lights, etc. Very similar to 5000 watt model to left, only larger. Size: 39 1/2" long, 25" wide, 28" high. Fuel consumption, 0.182 gal. per KW hour full load. Has four cycle, 20 HP direct driven gasoline engine/generator. Manual and remote models include same equipment as 5CW to left.

10CW-3M Manual start 115/230V, 60 cycles, 10,000 watts	\$1295.00
10CW-5M Same as above but 230V only	1395.00
10CW-3R Remote start 115/230V, 60 cycles, 10,000 watts	1395.00
10CW-5R Same as above but 230V	1495.00

ELECTRIC GENERATING PLANTS

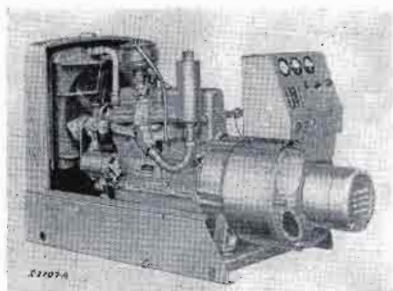

25,000 Watts

A heavy duty plant. Ample for 5KW broadcast transmitter, tower lights, accessories, and building lights. Has 6 cylinder Ford engine, directly driving a revolving field type generator. Voltage regulation $\pm 2\%$. Frequency within 3 cycles. Includes high water temperature automatic cut-off, 12 volt starter, voltage regulator, voltmeter, ammeter, start-stop switch, water temperature gauge and oil pressure gauge. Fuel consumption 0.14 gal. per KW hour full load. Size: 80" long, 41 1/2" high, 33" wide. Shipping weight, 2025 lbs.

25EC-5DR8 Three phase, 3 wire, 240 volt with 120 volt tap on 1 leg for nominal accessory loads	\$2380.00
25EC-4R8 Same as above only 208 volts with 120 volt tap	2380.00

NOTE: Other voltages and frequencies available on special order.

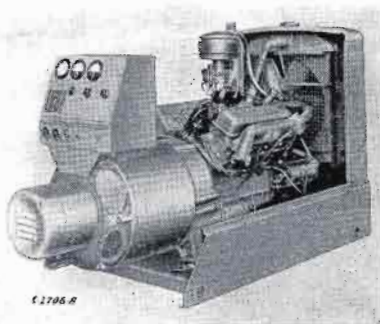

35,000 Watts

Very similar to the 25KW model listed to the left. A Ford V-8 engine powers the direct driven generator to produce 35,000 watts. Voltage regulation $\pm 2\%$ and frequency accuracy to 3 cycles. This model will easily supply a 10KW transmitter with tower lights, accessories and building lights. Some accessories are supplied as 25KW model to left. Fuel consumption, 0.14 gal. per KW hour full load. Size: 80" long, 33" wide, 41 1/2" high.

35ED-5DR8 Three phase, 3 wire, 240 volt with 120 volt tap on 1 leg for nominal accessory loads	\$2930.00
35ED-4R8 Same as above only 208 volts with 120 volt tap	2930.00

NOTE: Other voltages and frequencies available on special order.



Automatic Line Transfer:

Transfers automatically from the AC power line, when it fails, to the generator. Used only with remote control models listed above, and Pages 241-242. Typical popular types listed below. Many others available to meet any requirements.

Cat. No.	Voltage	Phase	Generator Rating	Price
LT10-21	115	one	1 KVA	\$125.00
LT60-21	115	one	up to 6 KVA	215.00
LT30-22	230	one	up to 6 KVA	215.00
LT30-25	230	three	10 KVA	230.00
		(3 wire)		
LT60-25	230	three	23 KVA	325.00
		(3 wire)		
LT100-25	230	three	37.5 KVA	425.00
		(3 wire)		

In Ordering Generators

Generating plants operate at full load extremely well. Safety factor is always considered in design. There is no need to add to safety factor in your computations. — If the generator desired is not listed herein, a model is available, either smaller or larger, to fit your needs. All generators are designed for continuous duty where properly installed and ventilated. Gates engineers will gladly assist in your generator selection. Send a simple statement of items to be operated, and voltage or voltages, and a complete proposal will be sent promptly.

Crystal Controlled FM Broadcast Receiver



Designed for 30-15,000 cycle response in rebroadcast of FM transmission, having low noise and distortion requirements for this service. Available in two models, for either 88-108 Mc or the 150 Mc band. As all receivers are crystal controlled to receive the specific frequency of transmission, about 30 days should be allowed for delivery.

Has self-contained monitor speaker for checking signal, field strength meter and is constructed on 7"x19" standard rack panel. Power supply is self-contained. Emphasis has been placed on sensitivity, negligible drift and signal-to-noise ratio. Signal-to-noise ratio is 50 db or better and sensitivity is 10MV for 40 db quieting or 2 MV for 20 db quieting. — Output, 600/150 ohms. Accommodates either 72 ohm or 300 ohm antenna. For 115-125 volts, 50/60 cycles.

Model CM for 88-108 Mc less crystal	\$295.00
Model CM-150 for 150 Mc band less crystal	350.00
Crystal and holder	7.50

NOTE: Specify frequency when ordering, as receivers are crystal controlled for single frequency operation only.

TV Equipment

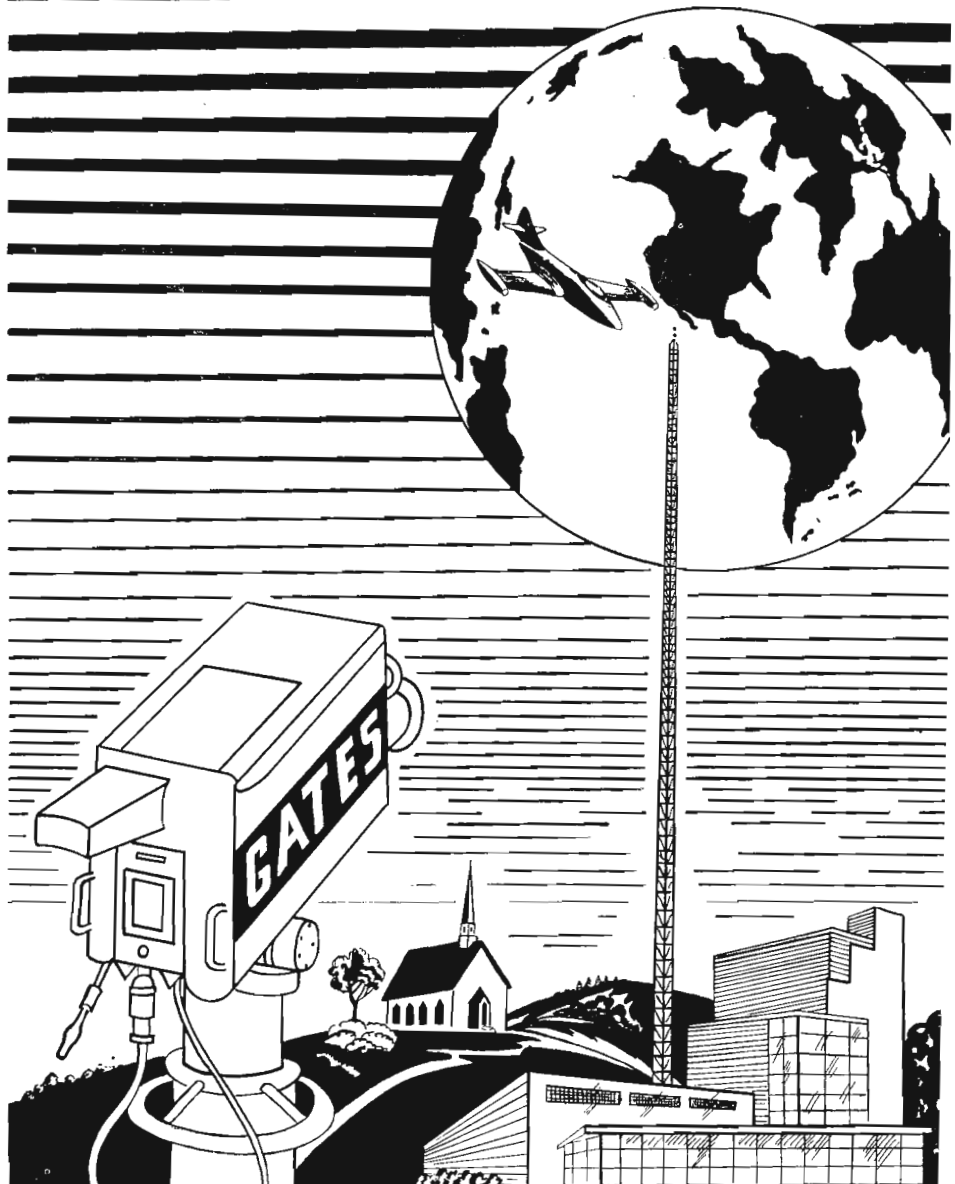

GATES

100 WATT TV TRANSMITTER

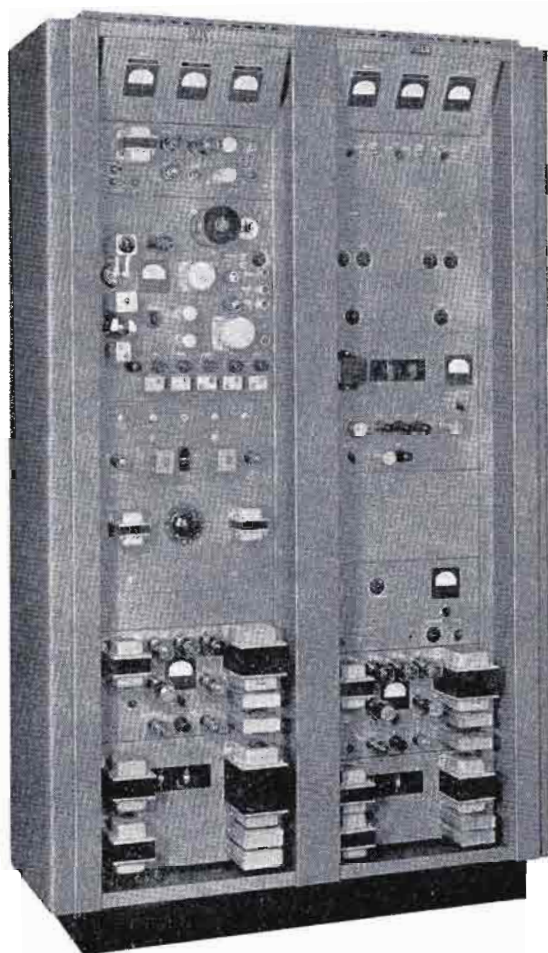

Low power television or satellite operation is becoming more and more popular. For VHF channels 2-13, the BT100A excellently fills this need in providing both picture sharpness and aural quality second to none. — The BT100A transmitter is built in two standard rack cabinets. Use of vertical construction assures 100% access to all parts. — Top quality characteristics of Gates equipment is certainly amplified in the BT100A transmitter by fine workmanship and the use of the best components money can buy.

BT100A TELEVISION TRANSMITTER

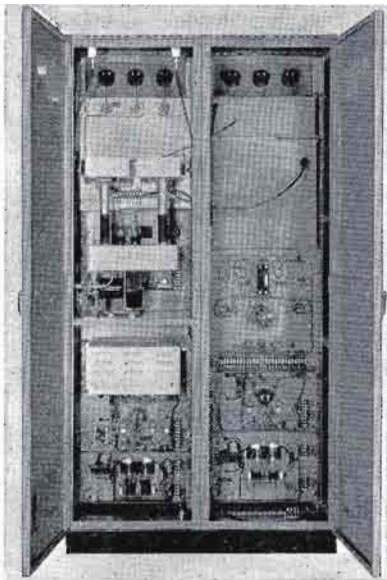

Rear BT100A view. Left cabinet contains visual and aural power amplifiers, visual exciter, modulator and power supplies. Right cabinet, demodulator, aural exciter, control and protective panel and power supplies.

The Gates BT100A television transmitter is a complete aural-visual equipment ready to attach to aural and video input and antenna. Though the maximum power rating is 100/60 watts for visual-aural, the BT100A may be operated at lower powers, also. Ideal as a low power TV transmitter, it may also be employed as an exciter for higher powered transmitters and will find good acceptance for production line testing of TV receivers as well as laboratory use.

The aural section of the transmitter consists of an exciter modulator and a power amplifier. Referring to the block diagram on the next page, the oscillator is crystal controlled with the output coupled to the shaping and modulating circuits. Audio voltage is applied in such a manner to cause a phase shift in the oscillator frequency of the audio rate. The oscillator

frequency is then multiplied through a series of multipliers to the operating frequency. The output of the exciter modulator is at operating frequency and is used to drive the power amplifier. Conventional circuitry is used throughout.

Visual section design consists of an RF exciter, video modulator, and power amplifier. The exciter multiplies the crystal oscillator frequency to the operating frequency and at the proper power level to drive the power amplifier. The modulator is a video amplifier that amplifies a standard video input voltage to the power required to modulate the power amplifier. The power amplifier is grid-bias modulated. A diode is used to restore the DC component at the grid of the modulating stage. The modulating stage is DC coupled to the grid of the power amplifier.

A direct reading power output and VSWR indicator is standard equipment. Also provided is a video demodulator wave form and modulation monitor, indicating modulation percentage and wave shape. The monitor output may be attached to a wave form or picture monitor.

Vertical construction is employed for ease in servicing. Cabinets are finished in hand rubbed gloss gray and provided with full length rear doors.

(continued next page)

Specifications --- Ordering Data, BT100A

SPECIFICATIONS

	Visual Section	Aural Section
TYPE OF EMISSION:	A5	A3
FREQUENCY RANGE (channels):	2-13	2-13
POWER OUTPUT:	100 watts	60 watts
RF OUTPUT IMPEDANCE:	51 ohms	51 ohms
CARRIER STABILITY:	±1000 cycles	±4000 cycles
MODULATION CAPABILITY:	85%	±40 Kc
METHOD OF MODULATION:	Amplitude grid modulation of PA stage	Phase, employing pulse timing
FREQUENCY RESPONSE:	±2 db at 500 Kc ±2 db at 1.5 Mc ±2 db at 2 Mc ±2 db at 3 Mc ±3 db at 4 Mc	±1½ db 30 to 15,000 cycles
INPUT IMPEDANCE:	73 ohms	600/150 ohms
INPUT LEVEL:	1.4 VPP	10 dbm
DISTORTION:	—	1½% or less
NOISE:	—	FM: 55 db below 100% mod. AM: 50 db below 100% mod.

POWER INPUT: 117 volts, 50/60 cycles, 1700 watts.
 SIZE: 50" wide, 84" high, 21" deep.
 OPERATION CYCLE: Continuous duty.
 WEIGHT: 1400 lbs. approximate.
 CUBAGE: 68 cu. ft.

TUBES: One each, 6X5, 6BA6, 6V6, 6SN7, 829B, AX9903, 6CD6, 6AL5, 6AH6, 6CL6, 5V4, VR105; two each, 6SH7, 12AY7, 12AX7, 815, 4X105A; three each, OC3, 6AG7, 6SJ7; four each, 866A, 5U4G; seven each, 6AS7/G.

ORDERING INFORMATION

Cat. No.

Complete 100 watt TV transmitter for 100 watts video and 60 watts aural output, with one set of tubes, two crystals and ovens	BT100A
100% spare tube complement	TK-212
Spare crystal and oven for visual section	JK09
Spare crystal and oven for aural section	JK07E

PRICES: See pink supplement, rear of catalog. Be sure to state channel when ordering.

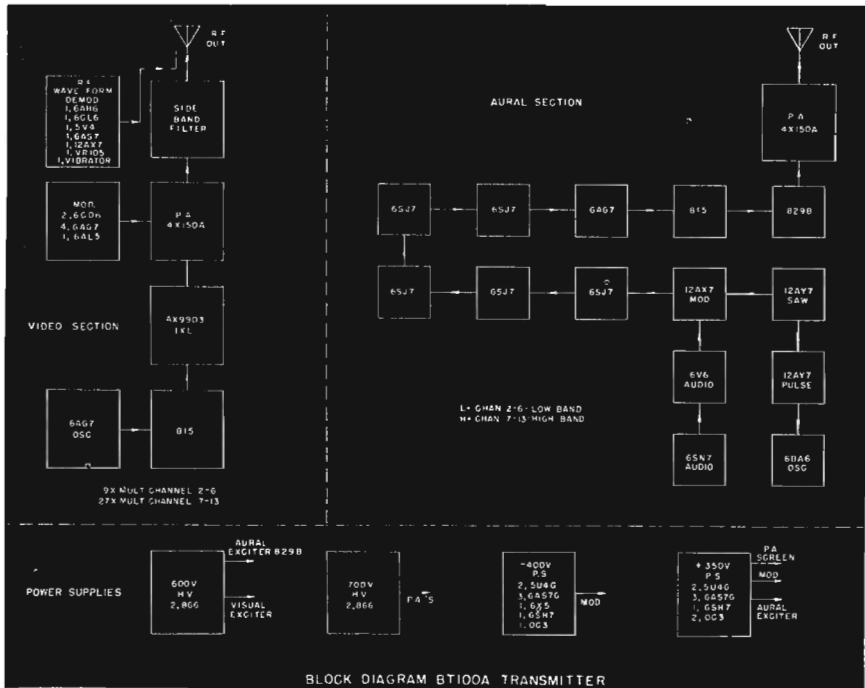

500 WATT TELEVISION TRANSMITTER

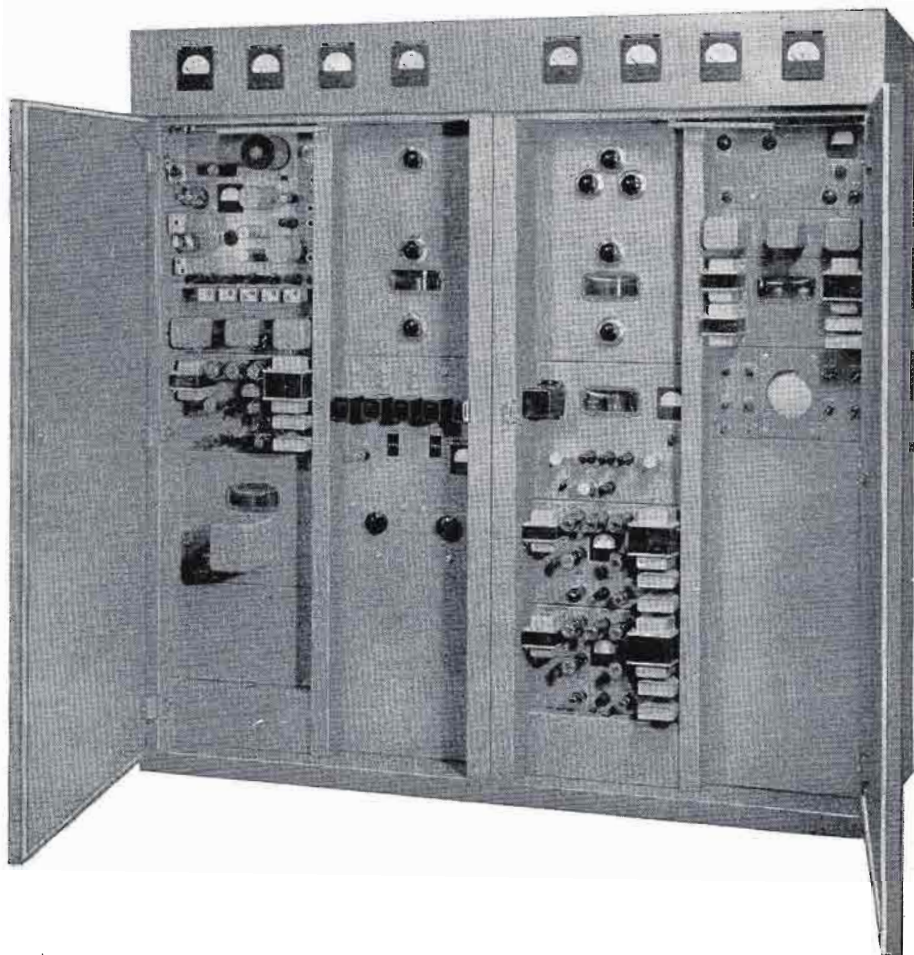

For either the experienced engineer or the engineer tackling TV for the first time, the straightforward, easy to service and completeness of the Gates BT1A, 500 watt transmitter will be appreciated. — Often an accessory, but built into the BT1A is a wave form and modulation monitor. Variable power-stats in both AC and plate voltage supplies assures absolute correct operating voltages whether input voltage is higher or lower than normal. Added to fine performance is conservative design and the feature standard in all Gates designs—instant accessibility to all components.

BT1A 500 WATT TV TRANSMITTER

A wealth of background in VHF and UHF transmitters has aided materially in BT1A design. Essentially two transmitters, visual and aural are in two separate cubicles that join together at time of installation. — Visual transmitter consists of only four radio frequency stages. This provides unusual operating simplicity. The visual modulator is also less complicated, having only three stages including modulator tube. — Aural transmitter is phase modulated at the crystal frequency and multiplied as much as 1296 times for the top channel 13.

Reflectometers to indicate both VSWR and power output are provided for both aural and visual units. Five power supplies, three of the regulated type, add to transmitter stability. A generous supervisory relay and circuit breaker complement assure full protection of the valuable tubes and components. — Fifteen meters indicate every desirable current and voltage, even including sections of the regulated power supplies, important in picture quality. — Full length front doors protect tuning adjustments even though dead-front design is followed.

(continued next page)

Roomy interior assures cool operation and ease of maintenance. Incoming air is filtered. Double back doors allow walk-in-to-service.

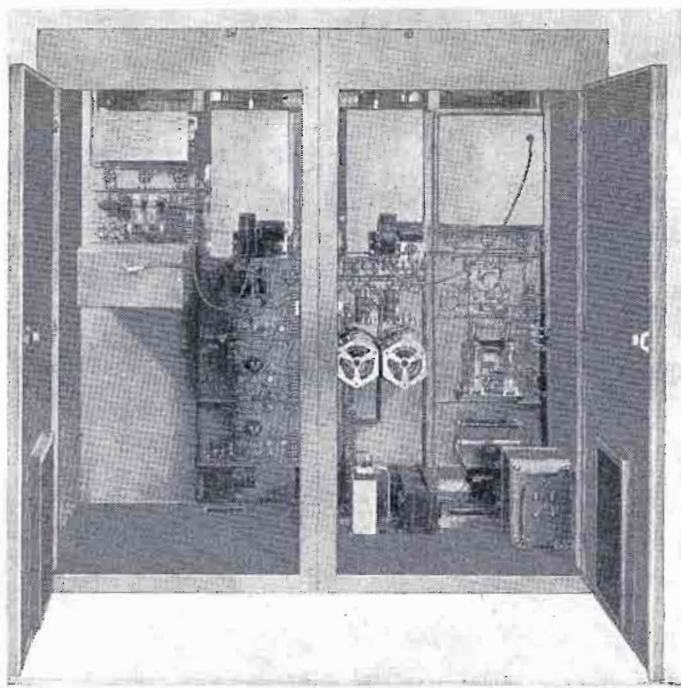

BT1A 500 WATT 2-13 TV TRANSMITTER

SPECIFICATIONS

- FREQUENCY RANGE:** Model BT1A-L, channels 2-6.
Model BT1A-H, channels 7-13.
- RATED POWER OUTPUT:** 500 watts visual, 250 watts aural.
- RF OUTPUT:** 51 ohms visual, 51 ohms aural.
- RF STABILITY:** Aural ± 4 Kc. Visual, ± 1 Kc.
- INPUT:** Visual, 75 ohms at 1.4 volts peak to peak.
Aural, 600 ohms at +10 dbm ± 2 db.
- MODULATION CAPACITY:** Aural, 100% equals ± 25 Kc swing.
Visual, 90%.
- AURAL RESPONSE:** $\pm 1\frac{1}{2}$ db 50-15,000 cycles.
- VISUAL RESPONSE:** ± 2 db at 0.5 Mc.
 ± 2 db at 1.25 Mc.
 ± 2 db at 2 Mc.
 ± 2 db at 3 Mc.
 ± 3 db at 4 Mc.
- NOISE:** Aural, -60 db FM or -50 db AM.
Visual, (amplitude variation over 1 frame) less than 5% of sync peak level.
- TYPE OF MODULATION:** Aural, phase shift.
Visual, grid amplitude.
- BUILT-IN MONITOR:** Wave form and modulation monitor is built-in for visual section. — Direct power output and VSWR indicators built-in for both visual and aural sections.
- PRIMARY:** 230 volt, 60 cycle, single phase at approximately 14½ amperes load.
- SIZE:** 89" wide, 35" deep, 78" high. Door swing, 35".
- TUBES:** Following tubes used in both BT1A-L and BT1A-H:
(9) 6AS7, (6) 5U4G, (5) 6AG7, VR105, 6SJ7, (4) 12AY7,
(3) 6SH7, 6CD6, (2) 866A, 8008, (1) 6V6, 6SN7, 12AX7,
6BA6, 6X5, 5BP1A, 1X2, 6X4.
—add to above for BT1A-L only: (4) 4-400A, (2) 815,
829B, (1) 6AG7.
—add to above for BT1A-H only: (4) 4-250A, (2) 5894,
5763, (1) 815, 829B.
- METERING:** Eight 4" meters and seven 3" meters reading: RF Power/VSWR Visual, RF Power/VSWR Aural, PA Grid Aural, PA Filament Aural, PA Plate Aural, PA Plate Visual, PA Filament Visual, Plate Volts both Aural and Visual, Multi-meter Visual Exciter, Multi-meter Aural Exciter, Screen Current PA Visual, Line Volts AC, 3 Multi-meters for the 3 regulated power supplies.
- POWER CONTROL:** Variable front panel control powerstats allow full 0-maximum control of both primary line voltage and DC high voltage to power amplifiers.
- SIDEBAND FILTER:** Vestigial standard equipment.
- SHIPPING WEIGHT:** 3300 lbs. Cubage, 71.

Ordering Information --- BT1A Transmitter

SUPPLIED AS STANDARD EQUIPMENT: transmitter, instruction manual, one set of tubes, one JK09 crystal and oven for visual, one JK07E crystal and oven for aural, installation hardware and electrical jumpers.

OPTIONAL EQUIPMENT: spare tube set, spare JK09 crystal and oven, spare JK07E crystal and oven.

ORDERING INFORMATION

Transmitter for channels 2-6 as outlined in "standard equipment" above	Cat. No. BT1A-L
Transmitter for channels 7-13 as outlined in "standard equipment" above	BT1A-H
Spare crystal and oven for visual	JK09
Spare crystal and oven for aural	JK07E
Spare 100% tube complement for BT1A-L	TK-160
Spare 100% tube complement for BT1A-H	TK-258

WHEN ORDERING: Be sure to state channel of operation. For other primary voltages, special primary voltage changing transformers are available.

PRICES: See pink supplement, rear of catalog.

Functional diagram of BT1A-L, 500 watt TV transmitter.
BT1A-H varies only slightly in tube complement, see tube listing.

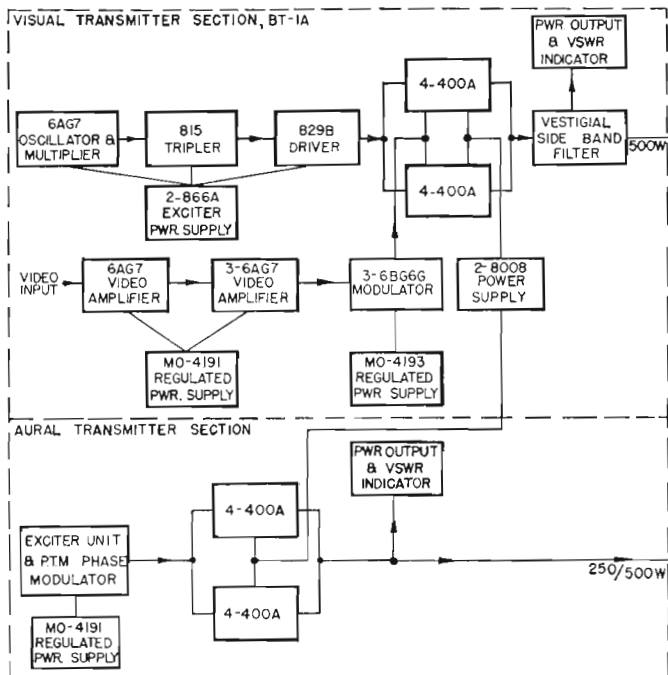

ANTENNAS FOR TV AND FM

Model TV-100/TV-500

This antenna is designed specifically for low power TV. Consists of two sections of two rings each. One section is for visual and the other for aural. With this method, the diplexer is not required. As each ring has a power gain of 0.7, the two rings when stacked provide a power gain of 1.3. Thus, when used with normal transmission line lengths, unity power output is had, or a 100 watt transmitter will have an ERP of approximately 100 watts, or a 500 watt transmitter an ERP of approximately 500 watts.

Pattern is essentially omni-directional. Includes mounting mast with top plate for either a 300 MM code beacon or obstruction light. Rings are provided with connecting coaxial cable and matching stubs. Each antenna is tested prior to shipment. Impedance 51 ohms. Size of rings and spacing varies as to channel.

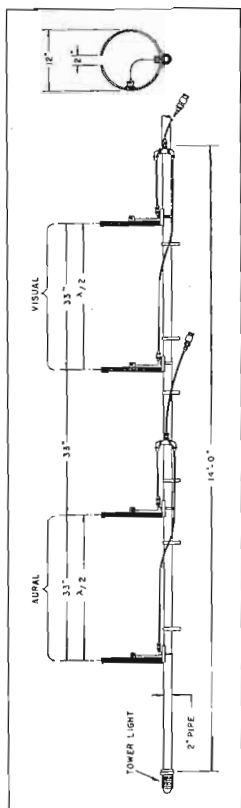

TV-100-L for 100 watts, channels 2-6	\$1350.00
TV-100-H for 100 watts, channels 7-13	1200.00
TV-500-L for 500 watts, channels 2-6	1475.00
TV-500-H for 500 watts, channels 7-13	1325.00



Broad Band FM Antenna

An omni-directional antenna for the 88-108 Mc FM band, having a power gain of 0.8. Primarily designed for FM educational band but may be used at powers up to 3KW. Design is broad band, greatly reducing standing wave problems due to changing climatic conditions. State frequency when ordering.

FM-11 Broad band antenna
\$50.00

Multi-V Antennas

Omni-directional, this popular Andrew antenna for FM in the 88-108 Mc band is available in 2 and 4 bay types. Power gain of 2 bay is 1.6 and of 4 bay, power gain is 3.7. — Mounts on side of tower. Light weight of approximately 100 lbs. for 2 bay or 175 lbs. for 4 bay allows use on nearly any type of tower. Power rating up to 10KW. Standard design is for use with 1 5/8" coaxial cable. However, smaller cables may be used by purchasing a simple reducer as listed below.

Model 1302 Two bay antenna
\$435.00

Model 1304 Four bay antenna
\$1150.00

Model 4874 Reducer to RG17U coax
\$20.00



GPL TELEVISION CAMERA EQUIPMENT

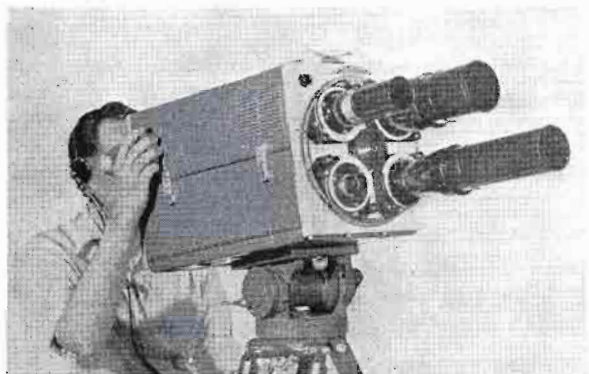

- Push-button lens change.
- Focus accomplished by positioning image orthicon actuated by servo-mechanism facilitating unusual effects using extreme close-ups.
- Intercom for single or split headphones.
- Iris mechanism disengages as turret is swung. Re-engages without affecting previous lens setting.

A portable studio and field chain of the image orthicon type including image orthicon camera with electronic viewfinder, camera control unit, camera power unit, cable accessories and optional remote control unit. This chain may be integrated into existing installations and operated from presently installed synchronous generators. — All units are modest in size, are compact, portable, easy to operate, service and maintain. For either studio or field, this is one of the finest camera chains manufactured today.

BASIC CHAIN INCLUDES: PA601 camera, PA602 camera control unit, PA603 power supply, PA801 interconnecting cables (less camera cable), PA802 tube complement (less orthicon) and two sets of intercom headsets. — Complete listing of basic and optional equipment will be found on the following pages and the pink supplement price list in the back of this catalog.

Basic Camera Chain Cat. PA600

- Unusual serviceability. Electronic components may be serviced while operating.
- Cue lights switched from camera.
- High capacity cooling blowers.
- Target heater provided.

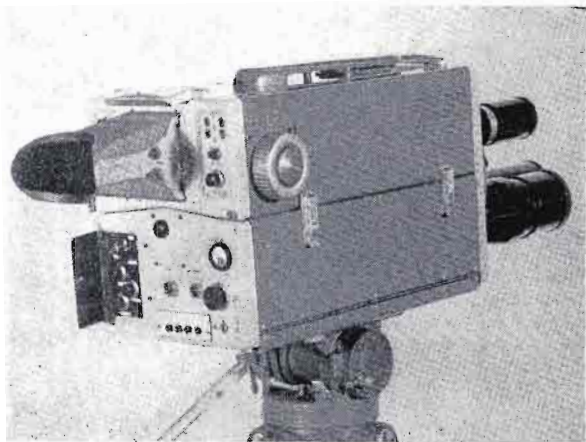

GPL --- Camera Control Unit --- Power Supply



Camera Control Unit

Standard equipment with basic GPL PA600 camera chain. Has 8 1/2" monitor tube, target and beam controlled by thumb wheels, 3 position intercom, (1) all talk, all listen, (2) director, CCU talk, rest listen, and (3) private line camera to camera. Meter indicates lens stop setting of action lens. Wave form monitor indicates vertical or horizontal trace with fast sweep of vertical permitting observation of vertical pulses. Picture monitor controls under hinged cover. Proper target voltage by depressing push-button. Excellent maintenance design.

Camera Control Unit Cat. PA602

Camera Power Unit

Supplied as standard equipment with PA600 camera chain. A compact portable unit that supplies all power to camera and the PA602 camera control unit. Side panel swings down for complete serviceability. All components are on standard relay rack panels for permanent studio installation, if desired.

Camera Power Unit Cat. PA603

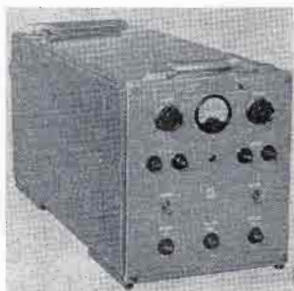

Synchronous Generator

This necessary equipment in TV station operation combines the stability of binary counting with the accuracy of delay lines for determining pulse width. — A stable master oscillator which can be free running, is locked to the 60 cycle power source or slaved to an external crystal source. Provision for operating with a sync generator slaving unit has been included. Power supply is self-contained. Above the oscillator is the binary counter. — Outputs are standard RTMA. Size: 17" high, 26" long, 10" wide. Weight, 75 lbs.

Portable Synchronous Generator Cat. PA604

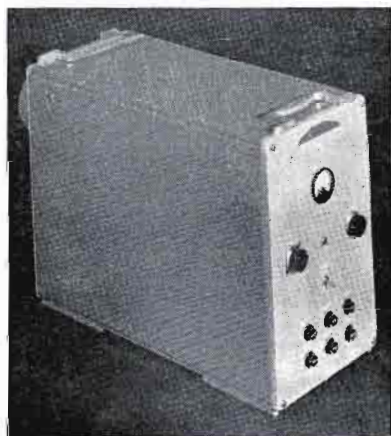

- Compact, readily portable.
- Inbuilt power supply.
- Requires no adjustment after initial setup.
- Designed for easy maintenance.
- Standard rack panel for adaptation to rack mounting.

PRICES AND ACCESSORIES

Due to the wide variety of accessories such as numerous lens sizes, camera cable lengths and tube kits, the complete listing and grouping of these items along with major items listed on these pages will be found on the pink supplemental price list—back of catalog.

GPL Television Broadcast Equipment

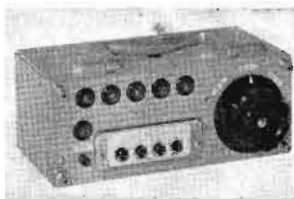

Camera Remote Control Unit

Provides many unusual and exclusive features for the remote control of camera focus and lens change. Styled to match other GPL units.

Camera Remote Unit
Cat. PA610



Master Monitor

Styled for use with GPL image orthicon camera, the PA606 master monitor may be used for monitoring picture and wave forms at any part of the TV station and independent of camera chain. — Normally used with video switches to check output and input or an "effects" picture, a second monitor may be connected for dual monitoring of outgoing and preview signals. — Monitor may be either synchronized or driven — Size: 17"x28"x10". For 90-130 volts, 60 cycles.

Master Monitor Cat. PA606

Master Monitor Features:

- 3 preset video inputs.
- Inputs, composite or non-composite.
- 8½" tube.
- 3" wave form monitor.
- Self-contained power supply.
- Complete metering.

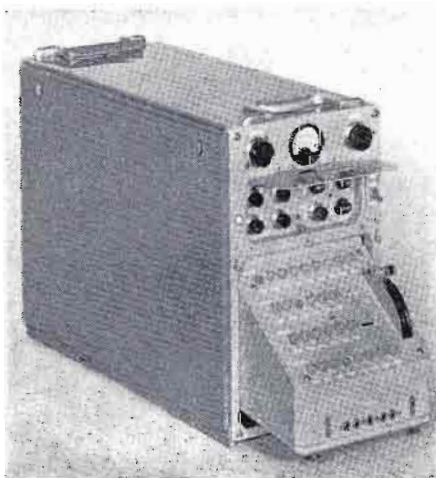

Drop-down switching panel folds in when not in use, protecting switches.

Video Switcher

This video switcher gives complete flexibility of studio switching. A compact portable unit matched to other GPL equipments. Switch-buttons automatically illuminate when button pressed. Uppermost switch bank is the monitor bus. Here, 5 camera, 2 remote and outgoing lines may be viewed. Two effect buses handles, dissolves and fades, controlled by twin fading levers. The bottom row switching bus picks up any camera, remote or effects bus, as desired. — The video switcher allows airing through the line bus while permitting switching function for rehearsal, with complete flexibility. Size: 17"x18"x10" closed. 17"x36½"x10" open. For 90-100 volts, 60 cycles.

Video Switcher Cat. PA605

GPL VIDICON FILM CHAIN

Represents a most advanced design in film equipment, and greatly improved film transmission is obtained. Stable black level and complete absence of spurious signals, eliminates need for constant attention. There are no edge or back lights. Gain and set-up are only operating controls. Supplied as basic equipment are:

- Camera and relay optical system.
- Base pedestal.
- Control panel (illustrated bottom page).
- Video and sweep chassis with bias and regulated power supply.
- All tubes including vidicon.
- Interconnecting cables except camera cable.

This system provides 525 lines, 60 fields interlaced with 7.5 Mc bandwidth and 600 line resolutions. Definition can provide full modulation to 300 lines. Rack space for center unit (right), 38". — Optional accessory equipment includes camera cable (see price list), multiplex mirror system, PA606 master monitor and PA100A telecast projector.

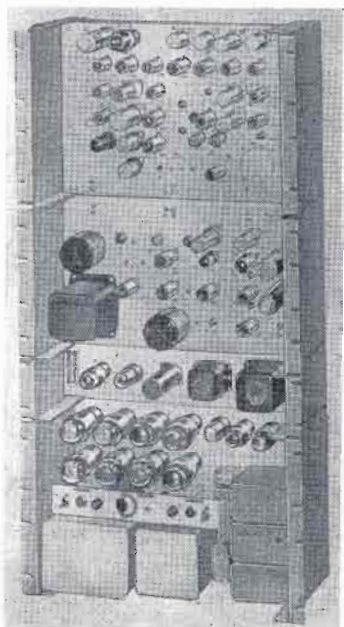
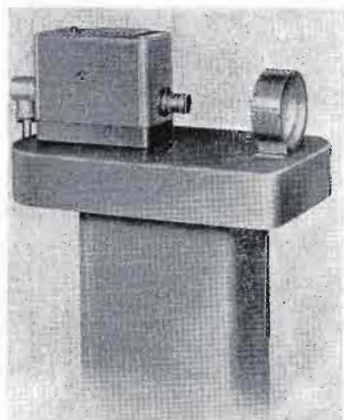

Vidicon Film Chain Cat. PA505

GPL TELECAST PROJECTOR --- MULTIPLEXER

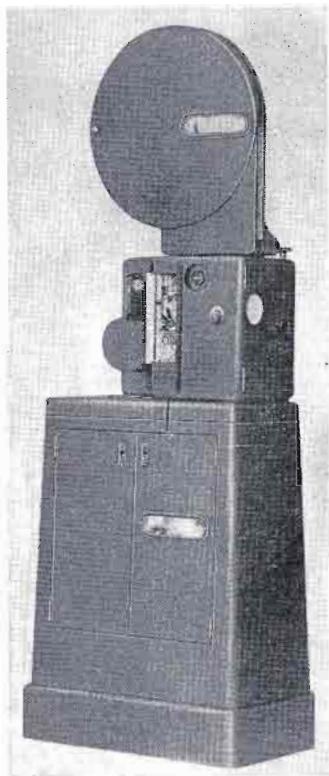

Professional in every sense of the word, this 16 mm projector meets the continuous service, minimum maintenance requirements demanded in film telecasting. Sound fidelity is in every way, equal to the fine crisp picture produced.

Flutter less than 0.25%. Sound flat to 7000 cycles with roll-off control for poor films. Exciter lamp of plug-in type with 30 Kc oscillator exciting the filament. Preamplifier output, +14 dbm with plug-in pads for lower levels. Impedance 50 to 600 ohms. 3 phase synchronous motor with DC excited field for correct lock in. Separate take-up motor for handling reels to 36". Low speed intermittent sprocket only 120 RPM. Optical system has dynamic resolution and flatness of field exceeding 600 lines in center and all four corners simultaneously. Corner illumination at least 85% of that at center.

Size: 27"x16"x78". Weight, 395 lbs. Power: 208V, 3 phase, and 110V, one phase. Height of optical axis above floor, 48" ±1". Lens, 3½" B & L Super-cinephor. Magazines, 3600 ft.

Telecast Projector Cat. PA100C



Multiplexer System

Provides maximum light transfer from any one of three projectors to a TV film chain camera. Utilizes electrically controlled moving mirrors, fully silvered for transmission close to 100%. Two of the mirrors are relay controlled by motors. Through the control panel, the correct mirror is push-button selected. Only 1/5 second required for change.

Multiplexer with pedestal Cat. PA525
Power Supply, 24 volts DC Cat. PS-13

GPL---LARGE SCREEN TV PROJECTION SYSTEM

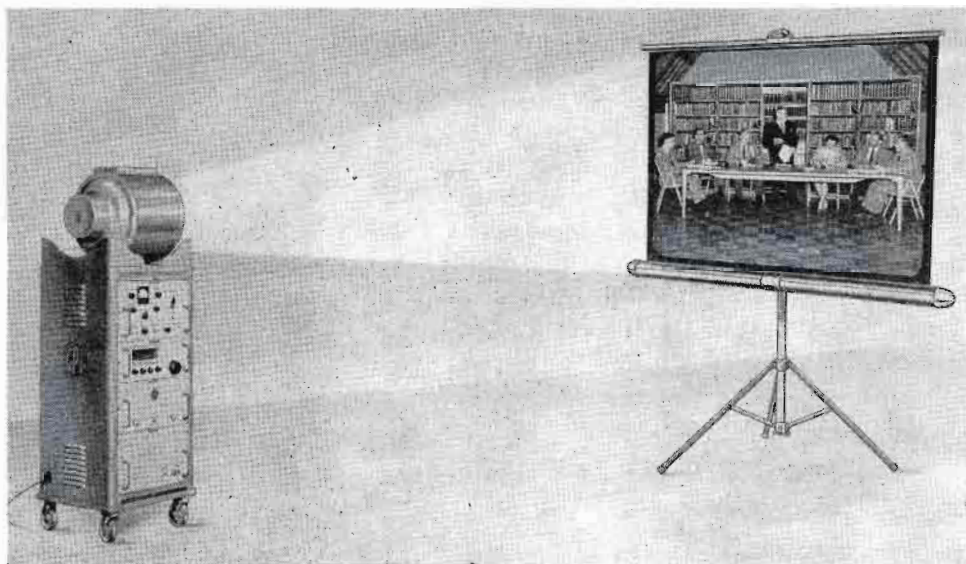

Use of the PB611B television projection system is well known for providing closed-circuit television in linking together as many as 50 cities across the nation. Consists of a complete system for both "Off-the-Air" and video line signals to project a picture 9' wide as used at teleseession activities, classroom, medical and other services, and up to as much as 16' wide with slightly less illumination as used in theatre events. Educational institutions, medical colleges, industrial plants and a host of other organizations and professions will quickly recognize the adaptability of this innovation in television projection equipment to their particular use.

Features:

- 1 — Bright, clear, high quality picture.
- 2 — Nine-foot wide picture recommended for teleseessions — up to 16 feet wide for theatre events.
- 3 — Permits intimate viewing by large audiences.
- 4 — Simplicity of installation and operation.
- 5 — Complete system for both "Off-the-Air" and video line signals.
- 6 — Control console is wheel-mounted for mobility.
- 7 — Regulated 40 KV power supply provides brilliant, steady pictures.
- 8 — Projection kinescope face cooled by built-in blower permitting maximum brilliance.
- 9 — Professional type TV receiver covers both VHF and UHF stations.
- 10 — High quality sound circuits feed standard PA system.

GPL---LARGE SCREEN TV PROJECTION SYSTEM

The GPL Television Projection System, Model PB611B, is a professional type television projection equipment, designed to provide bright, clear pictures up to 16' in width under favorable ambient light conditions. It is engineered to emphasize simplicity of installation and operation. System consists of a compact control console and a high-efficiency Schmidt optical system. Control console is mobile and contains:

- Projection Barrel.
- Sweep and Control Panel.
- TV Receiver.
- Video Amplifier.
- Low Voltage Power Supply.
- 40 KV Power Supply.

Chassis roll out on tracks and may be pivoted upward to provide easy access to all components. Special sweep failure protection circuits safeguard projection tube.



SPECIFICATIONS

INPUT POWER: 117 volts AC, 450 watts.

VIDEO INPUT: 75 ohms unbalanced—0.5 to 2.5 volts p-p.

AUDIO INPUT: 600 ohms, 0 db.

RECEIVER INPUT: 300 ohms.

AURAL OUTPUT: 600 ohms, 0 db (switch selects output from "Off-the-Air" receiver or audio line input, gain control provided).

VISUAL OUTPUT: 1.2 foot-candles highlight illumination with 8' picture width.

NOTE: To obtain reflected light values in foot-lamberts, multiply the 1.2 figure by the gain of the screen used.

SIZE: 66"x22"x18".

TYPICAL THROW DISTANCE: Where projector 10' from screen—picture width 5.4'.
Where 18' from screen—picture width 9.7'.
Where 30' from screen—picture width 16'.

Television Projection System Cat. PB611B

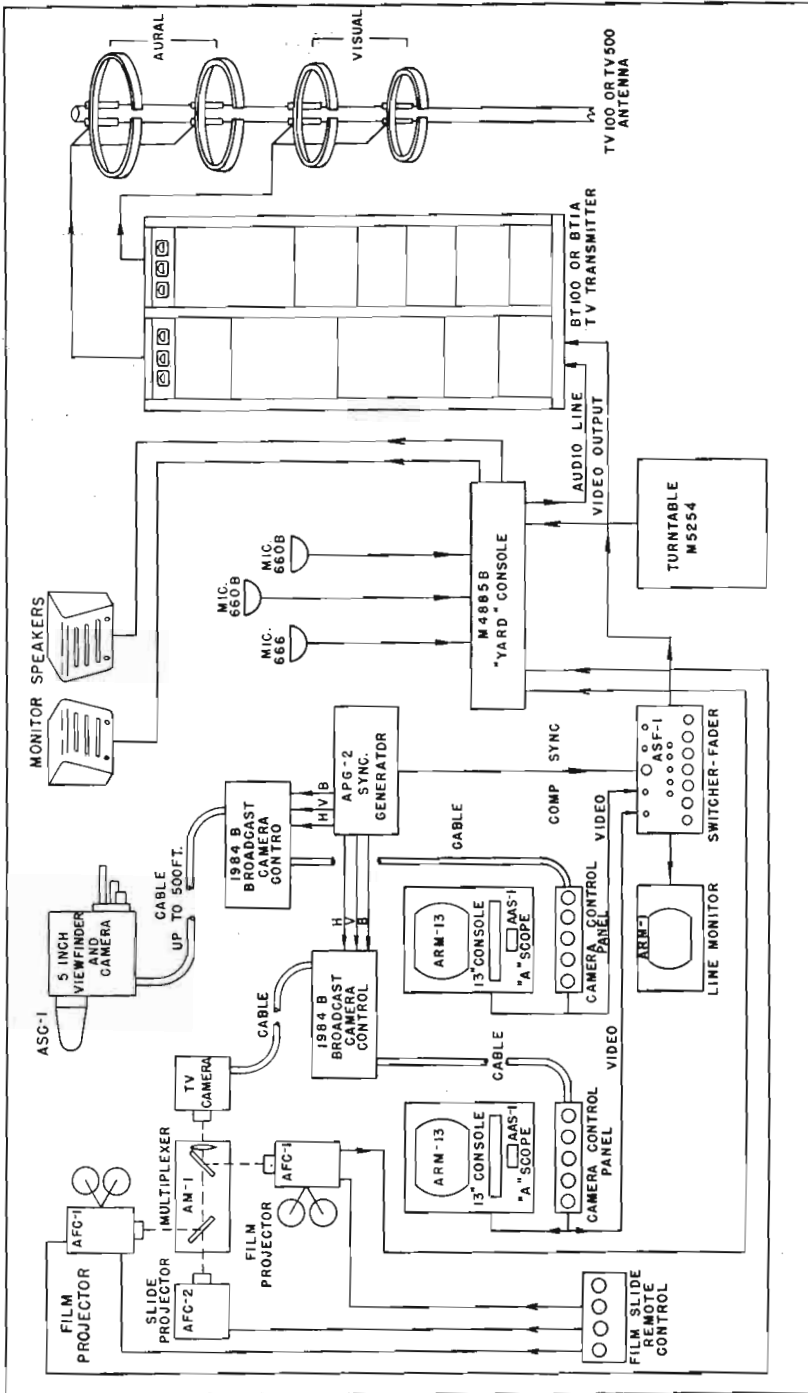

Above: Line drawing of typical low power TV installation using vidicon cameras. Expansion from this basic design is easily possible.

Kay Lab Television Camera --- Viewfinder

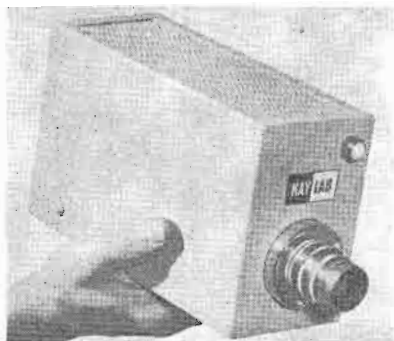

VIDICON CAMERA

Model 1984, manufactured by Kay Lab, is a light weight, compact device which converts the light image into a video signal. Supplied complete with camera control unit as listed next page. This camera is the basic unit for the studio and field camera with ASC-1 viewfinder as listed below. — Video response in

excess of 8 Mc. Includes jack in camera for intercom, protective circuit to guard pickup tube against power or cable failure, tally light and deflection switch. — Accommodates 16 mm type C lens. Size: 3½" wide, 5¼" high, 9½" deep. For lens variations and other accessories, see pink price list in back of this catalog.

Vidicon Camera, less vidicon tube and lens Cat. 1984

5" VIEWFINDER

An accessory which is added to the 1984 vidicon camera to direct and focus, through a four lens turret, the light image on the pickup tube. Provision is made



so that one of the four lens may be a 200 mm lens, focal length controlled from rear. The video signal is extracted from the camera and placed on a 5" cathode ray tube in the rear of the housing. Size: 8¼" wide, 10½" high, 12½" deep. Lens, tripods and other accessories listed in pink supplement in back of catalog.

Viewfinder, less camera
Cat. ASC-1

COMPLETE CAMERA, 1984 and ASC-1 Viewfinder,
including camera control unit Cat. 1984-BF

Kay Lab Television Equipment

Camera Control Equipment

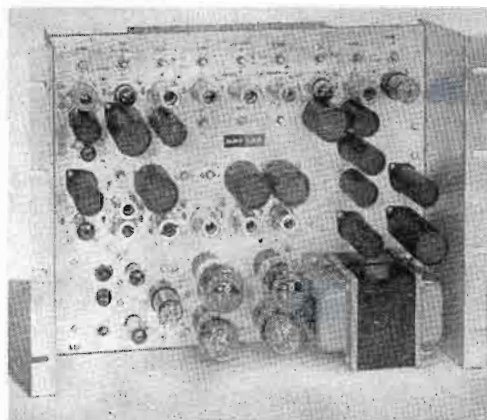
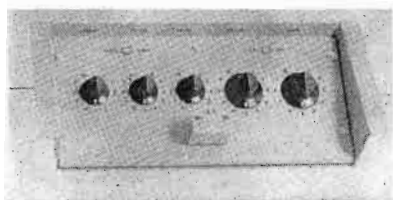

Above two units supplied with Kay Lab vidicon camera equipment for either studio film or live pickup. Control panel 13" wide of the "well" type and includes beam, target, focus, pedestal and gain controls. Control unit is rack mount and includes self-contained power supply. May be used with video monitor ARM-13A. The ASF-2 video switcher may be used for switching more than one camera chain. — This equipment supplied as part equipment with Kay Lab 1984 and 1984BY camera equipments.



Video Switcher—Fader

Switches and fader up to four camera units. Rack size, 19"x7". Easily mounts in desk unit, etc. Provides fade and switching for each camera unit plus sync and slow, medium, fast and instant control.

Video Switcher—Fader Cat. ASF-2

Master Monitor ARM-13A

Fine video monitor for either camera or outgoing line monitoring. 10" aluminized, tinted faced kinescope plus a 3" flat faced "A" scope for 1/2 line or 1/2 frame rate. Illuminated calibrated scale for "A" scope. — Contains video amplifier, deflection chassis and HV supply for kinescope, separate video amplifiers, deflection system and HV supply for "A" scope. Operates with standard black negative video signal 0.5-2V. For 118V, 60 cycles, 320 watts. Size: 18" high, 13" wide, 22" deep. — For 12" rack mounting or ACH-4 housing listed below and illustrated to left with monitor.

Master Monitor, less housing
Cat. ARM-13A

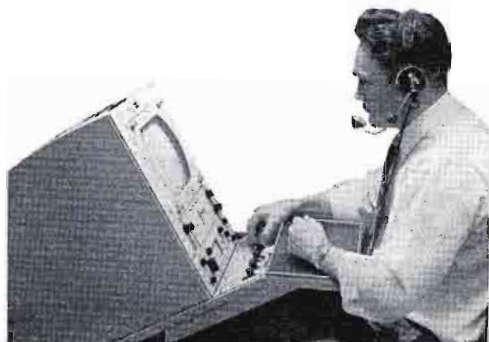

ACH-4 Housing

Shown above, holding master monitor. Also accommodates camera control panel and ASF-2 video switcher.

Housing Cat. ACH-4

Camera Chain, Monitors, Film Chain

Field Camera Chain

Complete field camera chain available with or without monitor and sync generator, as desired. Includes: camera with viewfinder, camera control, field monitor with 7" kinescope, sync generator, power supply, choice of lens (see combinations below). This system often used for studio as well as field service.

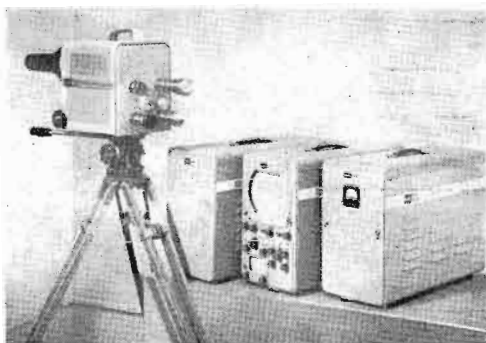

System 2A

1984B camera
6326 Vidicon
ASC-1 Viewfinder
AL-1 Lens 1/2" f/1.5
AL-2 Lens 1" f/1.5
AL-3 Lens 2" f/1.5
AL-6 Lens 3" f/1.5
Prof. Jr. Tripod
ATD-2 Dolly
50' Camera cable
50' Control panel cable

System 2B

All of System 2A plus
line monitor and
line amplifier

System 2C

All of System 2A plus
line monitor,
line amplifier and
sync generator



Remote Monitors

High resolution video monitors use the blanking pulses on the video waveshape for sync. Only one cable necessary. Monitors may be positioned up to 3000' from camera control. 10 and 17-inch monitors will fit in 19" rack cabinet. Bandwidth in excess of 8 Mc. Sizes: ARM-1, 12 1/4" x 19" x 19". ARM-2, 14" x 19" x 23". ARM-3, 19" x 21 3/4" x 20 3/8".

10-inch Monitor ARM-1
17-inch Monitor ARM-2
21-inch Monitor ARM-3

Film and Slide Chain

The following package consists of a complete two projector, one slide projector, camera chain. All items described on these pages except M-5369 mounting.

- 2 Bell and Howell 614-CBVM projector.
- 1 Gray 3B Telojector.
- 1 Gray 62A multiplexer, base.
- 1 Gray 63A shelf for mounting 3B Telojector to 62A base.
- 1 1984B vidicon camera with camera control.
- 1 6326 vidicon tube.
- 1 ACM-1 camera mount.
- 1 M-5369 camera pedestal with compartment for film reels and leveling screws.

Film and slide chain Cat. GR-7

Synchronous Generator

Standard RETMA sync generator designed to operate with any camera system listed herein. Studio type, rack mounting, complete with tubes and power supply.

Synchronous Generator Cat. APG-4

GRAY TELEVISION EQUIPMENT

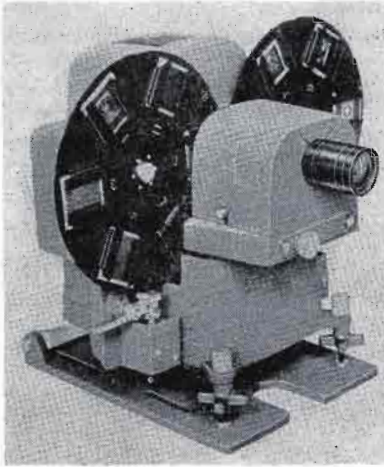

MODEL 3B TELECTOR accommodates twelve 2"x2" transparencies in an uninterrupted slide sequence of TV commercials, news photographs and station breaks. — Is automatic. Additional loaded turrets may be substituted in seconds. Features new optical mixing system. Superposes two images on one optical axis permitting smooth lap dissolves or instant switching. Designed for use with vidicon multiplexer. Iconoscope may also be used. Supplied with 6" or 7" coated lens as ordered. — For 115V, 60 cycles. Control circuit operates from 24 volts DC, 10 watts. — May be used with 35B manual control unit to produce superpositions, laps, fades and slide changes at desired rate and local/remote slide changes.

3B Telector, lens, automatic timer box and 2 slide turrets	\$695.00
35B Manual control unit	295.00
Additional turrets, 31L or 31R (L indicates left, R right)	14.00
63A mounting shelf, for mounting Telector to Gray multiplexers	130.00

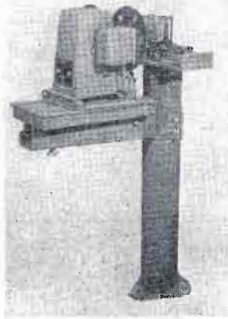

61A Multiplexer with 3B Telector and 63A Shelf.

61A MOVING MIRROR MULTIPLEXER

accommodates 3 optical sources of projection and reflect two into a single projector. Third projector may be placed on center line, behind multiplexer. A motor drive quickly shifts the two mirrors to permit third projector use. This may be remotely controlled. Illustration to left shows 3B Telector with 63A shelf attached to 61A multiplexer. Mirrors, 4 1/10" x 5 1/4". Center mirror to floor, 50". Base dimension, 11"x10". Weight, 106 lbs.

61A Multiplexer and base	\$450.00
--------------------------------	----------



62A Multiplexer with base.

62A TWO-WAY FIXED MIRROR MULTIPLEXER

handles two film projectors into single camera. By use of 63A mounting shelf, the 3B Telector can also be used. Height, optical center to floor, 48". With this system slides and film are handled with one setup.

62A Multiplexer and base	\$250.00
--------------------------------	----------

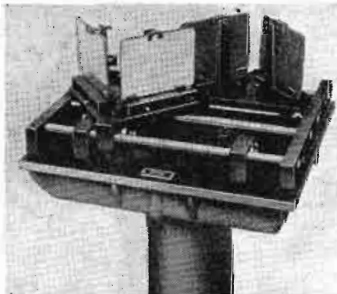

center mirror, 48". Multiplexer dimensions: 18" long, 16" wide, 50 3/8" high. Weight, 158 lbs.

60A Multiplexer with base	\$390.00
---------------------------------	----------

60A FOUR-WAY MOVING MIRROR allows operation of pairs of projectors into one camera or individually into two cameras. Mirrors at opposite ends of this travel on stainless slide rods, provide split operation of two projectors in separate cameras. Sliding either of the two mirrors to other end of travel, projectors are set for dual operation into one or two cameras. Mirror brackets adjustable. Mirror surface coated with quartz film to prevent marring. Height, floor to

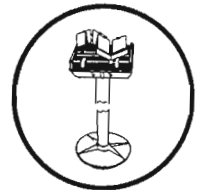

Sketch shows Multiplexer mounted on stand

GRAY TELEVISION EQUIPMENT

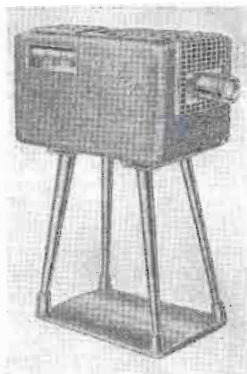

TELOP 2 (TV optical projector) allows projection of a wide variety of subjects on your TV camera. Easily prepared copy such as opaque cards, photographs, art work or 3 1/4"x4" transparencies. Provides in bottom, a space for actual television of small samples such as jewelry. Projects 2 pictures from 2 channels simultaneously. Varying light intensities produces fade in-out effects. Switching channels assures sustained program continuity. — Size: 34" long, 16" wide, 58" high. Weight, 600 lbs. Standard equipment includes 5 opening slide holders. Lens focal length, 18". For 115V, 20 amps.

Telop 2D, direct image for Iconoscope	\$2095.00
Telop 2R, reverse image for Iconoscope	2351.00
Telop 2RV, reverse image for RCA vidicon, TP-11 Multiplexer	2351.00
Telop 2DV, direct image for GE vidicon, Multiplexer	2095.00

TELOP 3 automatic slide projector handles both 4"x5" and 2"x2" opaque and transparent slides. It provides slide changes, lap dissolves and superposition of two opaque slides by push-button with either local or remote control. Up to 50 slides with one loading. Remote dimming, preventative for over-heating copy and unusual high level of "white" light. Quartz film coated mirrors. A channel provided for simultaneous projection on same optical axis for 2" transparencies by use of the 3B Telojector. — Size: 25" wide, 42" long, 56 1/2" high. Lens barrel 5 3/4". Center of lens to floor, 48". For 115V, 60 cycles.

Telop 3D, direct image for Iconoscope	\$3875.00
Telop 3R, reverse image for Iconoscope	3875.00
Telop 3V, reverse image for vidicon multiplexer	3875.00



CAMERA TURRET for using several projectors into one camera, 360° rotation on indexed stops. Ball-bearing, swivel. Camera height is adjusted by cradle with camera. Table height, 34". Diameter, 16". Base, 21"x18". Overall height, 37". Weight, 190 lbs.

55A Camera Turret \$425.00

VIDEO PATCH PANEL

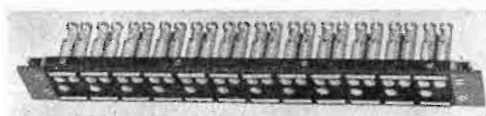

For patching coaxial 70 ohm circuits, 12 groups of 3 jacks on strip only 2 1/8"x19". Spring contacts heat treated beryllium copper. Outer braid of coax line may be soldered directly to jacks through 360° for complete shielding. — 967 and 965 patch cords and looping plugs plus a 995A color for uncoded color signals are illustrated below.

963 Video patch panel	\$215.00
965 Looping plug	6.50
967A Patch cord 18"	6.50
967B Patch cord 24"	6.75
967C Patch cord 36"	7.00
995A Color 18"	19.50



967



965



995A

Camera Tripods --- Klieglights

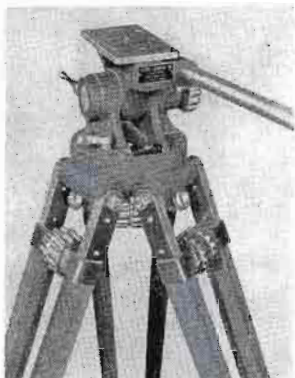

Spring Head Tripod

This model ideal for vidicon cameras weighing up to 25 lbs. Constructed with spring load tilt which assures camera returning to neutral position when lever is in unlocked position. Range, 44½" low to 73" high. Built-in spirit level. Model B triangle is optional base unit to keep legs from spreading and marring floors.

Professional Jr. spring head tripod.....\$200.00
Model B triangle 26.00

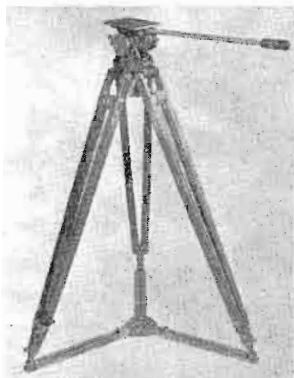

Friction Head Tripod

For vidicon or cameras 25 pounds or less. Equipped with friction type pan and tilt head, with tilt tension adjustment and pan and tilt lock levers. Equipped with spirit level. Range, 44½" low to 73" high. Legs of sturdy maple with quick positive locking devices.

Professional Jr. friction head tripod.....\$150.00
Carrying case for outside use 18.00

Kliegl Fresnel Lens Spotlights



Front and back spindle adjustment control. Heat resisting lens. Perfect light control without spill light or side glare. Adjustable from wide spread to minimum spot. Includes 3' asbestos leads and connector.

44N3TVG 3" lens, 100/150W lamp	\$ 20.00
44N6TVG 6" lens, 500/750W lamp	32.00
44N8TVG 8" lens, 1000/1500/2000W lamp	60.00
44N12TVG 12" lens, 2000W lamp	120.00
1420CR 19" roller caster floor stand for 6" and 8" lens models.....	27.00
1421CR 25" roller caster floor stand for 8" and 12" lens models.....	34.00

Kliegl Pole-Op 8" Fresnel

Turns, tilts, adjusts barn doors... all by pole... from studio floor. Has 8" fresnel lens and basic light design very similar to 44N8TVG listed above. Includes C clamp, swivel, asbestos leads and connector. Pole is accessory item. Size: 23½" high, including cradle, 13" wide and 13" deep.

44NP8G Pole-Op Klieglight\$88.00
44-Pole Sectional 12" pole, handle and loop 16.00

Lamp Sizes

For fresnel lights listed above, use following lamp sizes:

44N3TVG—100/150W Bayonet Base.
44N6TVG—500/750W T20 Med. PF Base.
44N8TVG —1000, 1500, 2000W, G40 Mog. PF Box.
44NP8G
44N12TVG—2000 watt, G48 Mog. BP Base.

DISCOUNTS: For TV stations only, now using Klieglights or buying Klieglights as standard equipment for new station, a 10% discount is allowed from Kliegl prices.

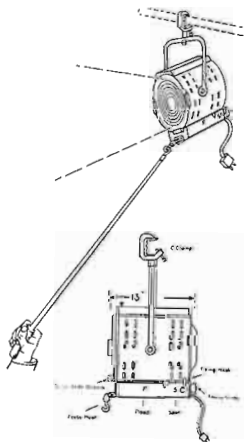

Klieglights --- Hanging Devices



Model 1365EG

Klieglights are spot-flood lights and differ completely from plano-convex and fresnel lens units. Klieglights have been perfected to a degree that arc spotlights are no longer needed. — Produce a brilliant, clear, uniform light, easily controlled and molded into any desired pattern. Perfect for highlighting areas or front spot lighting. Outstanding when used with projected scenery, as beam can be cut at any point. Available in hanging and floor models.

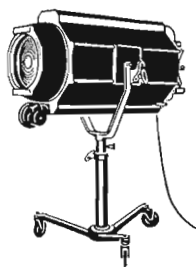

Floor model similar to 1174G and 1178G

- 1365EG Klieglight for 250/500/750 watts T14 Med. bi-pot base, up burning spot lamps. Included are reflector, 4 independently adjusted square framing shutters, 6" stepped lens, asbestos wires, yoke and C clamp. Hanging type \$ 47.00
- 1365EG-iris Same as 1365EG but with built-in iris shutter 63.00
- 1366EG Same as 1365EG but for 1500-2000 watt T base up burning, 200 hour life lamps 112.00
- 1366EG-iris Same as 1366EG but with built-in iris shutter 128.00
- 1174G Super Klieglight for 2000W T30 base up burning lamp. Rear operated curtain and iris shutter, 12" lens. Includes 25' cable, roller caster floor stand and switch. Rating, 450 foot candles at 4', spot at 25' 275.00
- 1178G Dyna-beam Klieglight similar to 1174G above but uses 3000W T32 base up burning lamp. Added feature, inbuilt rear operated horizontal spread lens which doubles width of projected spot when desired. Rating, 1000 foot candles at 4', spot at 25' 465.00



NEW 18" KLIENGL SCOOP FLOOR LIGHT has socket cap with universally adjustable yoke and C clamp, permitting straight down as well as up lighting. Spring tension adjustment. Light weight, ideal for field work. Hood of 16 gg Alzak-finished aluminum. Includes 3' asbestos leads, connector and takes P552 lamps from 750W to 2500W in size.

Klieglight TV1155G \$42.00



HANGING DEVICES

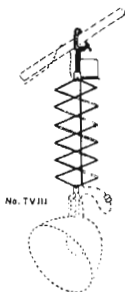

TV111—Single spring counter-balance raising and lowering device for use with models TV111 scoop and 44NGTVG fresnel lens units, 360° horizontal rotation and vertical tilt. Illustrated to left. Ideal method of positioning light where needed \$40.00

TV112—Same as TV111 only designed to hold fresnel lens model 44N8TVG \$40.00

TV113—Double spring counter-balanced device as illustrated to right for use with 44N12TVG fresnel lens light \$65.00

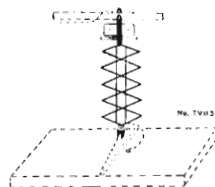

TV stations purchasing full Klieglight complement for initial installations or already using Klieglights and desire additions, may deduct 10% from Klieglight prices shown on these pages. Discount only applies to TV stations.

Bell and Howell --- TV Rebroadcast Receiver



BELL & HOWELL "614 JAN" is a new TV projector for 16 mm designed for use with vidicon film chains and having an important exclusive feature of being able to play back magnetic sound tracks as well as the normal optical sound track. Originally designed for the Army to JAN Specs, is self-evidence of ruggedness. Design eliminates need for synchronizing pull down with sync generator. Light output is 50 lumens with a 300W, 25 hour lamp. — All functions "On", "Off", "Show", "Forward" or "Reverse" may be remotely operated, if desired.

SPECIFICATIONS

REEL CAPACITY: 2000'.
 SOUND: Optical and magnetic.
 LOOP SETTER: Push-button.
 SHUTTER: 120 cycles per sec.
 LENS: 2" f/1.6 (up to 5.4 where desired).
 DISTORTION: 2% or less, 100-7000 cps.
 RESPONSE: 80-8000 cps $\pm 1\frac{1}{2}$ db.
 FLUTTER: 0.25% or less.
 POWER: 105-129V, 50/60 cycles.
 SIZE: (with pedestal) 51 $\frac{3}{4}$ " high, 12 $\frac{1}{8}$ " wide, 16 $\frac{1}{4}$ " long.
 Lens to floor: 48" ± 1 ".

614CBVM Projector complete with pedestal \$1995.00

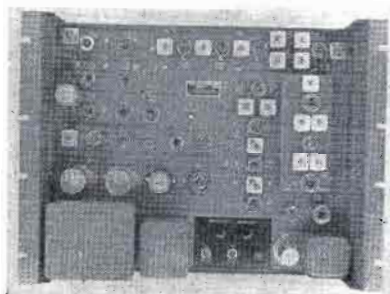

TV Rebroadcast Receiver

Model TR-1 meets specific requirements of a high quality receiver to pick up and rebroadcast TV signals. Provides signal quality equal or better than inter-city network facility. — Three outputs, video, audio and sync, are provided. Special circuits are provided to compensate for distortion caused by the transmitter sideband filter. Sound and video channels are separate so that failure of one will not disrupt the other. Effective automatic frequency control is so accurate that, even on channel 13, drift is negligible and will not impair picture or sound quality. Manufactured by Nems Clarke.

Specifications

VIDEO: Output, 75 ohm coax.
 Level, 1.5V, peak to peak.
 Response, to 4 Mc.
 SOUND: Output, +18 dbm 600/150 ohms.
 Response, 30-15,000 cps.
 Distortion, 1% or less.
 Noise, 70 db below +18 dbm.
 SYNC: Output, 75 ohm coax.
 Level, 4 volts p-p.
 MISCELLANEOUS: RF Input, 75 ohm coax.
 Power Supply, self-contained, 115V, 60 cps.
 Size: 19" wide, 13 $\frac{3}{4}$ " high, 8 $\frac{3}{4}$ " deep.

TR-1 Receiver for any one VHF channel \$850.00
 Additional VHF tuning unit for any VHF channel 75.00

Test Equipment --- Fans --- Recording Tape

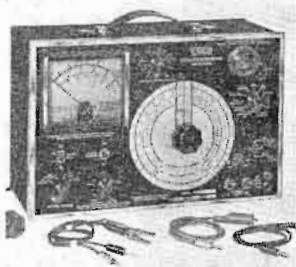

Capacitor-Resistor Analyzer

Performs 11 functions as follows: capacitance, resistance, power factor, insulation resistance, leakage current, continuity, open circuits, shorts, intermittents, high RF impedance and high power factor checks. Measures capacitance from 10 uuf to 2000 uf and resistance to 25 megs. Large 4½" meters. Size: 14" high, 9¼" wide, 5½" deep. Made by Pyramid.

Model CRA-1 \$82.95

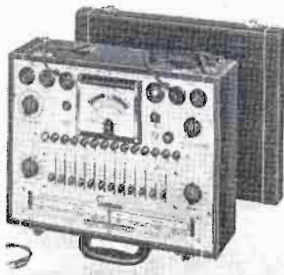

Plate Conductance Tube Tester

Tests any receiving tube, including 9 pin miniatures and subminiatures with base arrangements in a line or circle. Makes testing simpler. Multi-position toggle switches provide quick adjustment. Snap-Out-Snap-In transparent plastic windows are provided over the roll chart... add new tube data at any time. Line voltage: 105-125 volts, 50/60 cycles. Size: 15¾"x11¼"x6". Made by Simpson.

Model 1000 Tester \$135.00



3" Oscilloscope

Popular Hycon model features 4.5 Mc bandwidth within ±1 db (vertical amplifier), high deflection sensitivity, internal calibrating voltages, edge lighted bezel and special flat face 3" tube illuminates fringe distortion. Sweep ranges include V and H television frequencies. Size: 11"x8½"x10¼". For 115V, 60 cycles.

Model 617 \$269.50



5" Oscilloscope

A completely new 5" scope particularly adapted to random signals or low duty cycle pulses. Features automatic triggered sweep. Has 6 Mc ±3 db vertical band pass, flat face 5" tube, regulated power supplies, preset TV sweep frequencies and illuminated graticule with dimmer. Size: 13½"x10½"x18¾". For 115V, 60 cycles.

Model 622 \$426.00

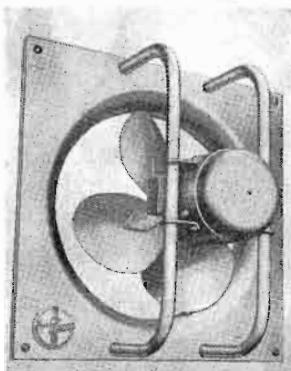

Peerless Exhaust Fans

Heavily built exhaust fans of commercial type for moving air in transmitter buildings. Totally enclosed permanent split capacitor type motor. For 115/230V AC. Single speed. Model PVS-16 moves 2150 cu. ft. per minute. Model PVS-24, 4550 cu. ft. per minute. PVS-16, Panel size 24".....\$110.00
PVS-24, Panel size 34"..... 170.00

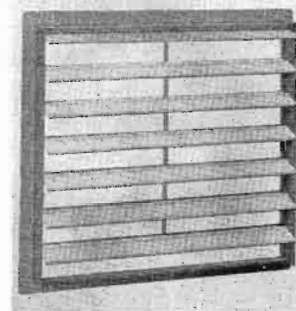

Automatic Louvers

For use with Peerless exhaust fans or outside of building. Automatically open and close when fan is on or off. Protects fan and building from weather and high wind.

Louvers for PVS-16 fan \$28.00
Louvers for PVS-24 fan 58.00

New Extra Play Recording Tape

Superstrong, PE polyester backing, weather balanced for extreme temperature and humidity—resistance from tropic heat or arctic cold. Made from DuPont "Mylog", tear resistant.



		Prices:	1 - 11	12 or more
150-9	¼"x900' plastic reel		\$ 2.93	\$ 2.64
150-18	¼"x1800' plastic reel		5.30	4.77
150-36H	¼"x3600' NARTB hub		10.67	9.90
150-36R	¼"x3600' NARTB 10½" reel		11.97	10.77
150-36RPS	¼"x3600' RETMA 10½" plastic reel		11.97	10.77

Headphones, Keys, Wire, Test Sets



Brush Type A

The popular headset in broadcasting. Bimorph crystal drive element assures response to 8000 cycles. High impedance. Has 5' cord.

Brush Type 200A
Headphones \$10.50

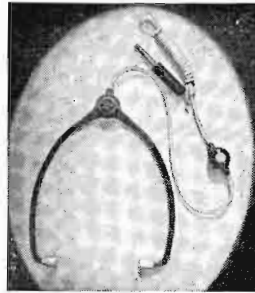

Telex Monoset

New comfort in headsets. Fits under chin. Made of Tenite. Weight 1.2 oz. Sensitivity 88 db above .003204 dynes per sq. ct. for 10MW input, impedance 2000 ohms.

4625, less volume control \$ 7.50
2841, with volume control 10.26



Telex Twinset

Sound piped to ear through slender tubular sound arm. Impedance 1000 ohms. Weight 1.6 oz. Tenite construction with Z nickel headband. Sensitivity 101 db above .000204 dynes per sq. ct. for 10MW input.

3775 Twinset \$10.95



Semi-Automatic Key

Improved standard model mounted on heavy steel base 6 1/4" x 3 1/2" x 1/2". Five adjustments assure dependable operation at all speeds. Complete with circuit closing switch and adjustable weight. All parts have heavy chrome plating. Contacts 1/4". Base chrome plated.

114-501 Key \$21.65
114-501L Left-hand Key 21.65



Heavy Duty Key

Large 1/4" coin silver contacts, chrome base. Navy type knob. Adjustable steel bearings and well designed spring give light keying touch. Finest hand key money can buy.

114-321 Key \$5.85

Shielded Audio Wire

2 conductor No. 20 stranded, cloth and heavy cotton fabric with tinned copper shield overall. Finest quality for inter-wiring of studios. Standard in industry.

SH20 Shielded studio wire:
less than 1000 ft. per ft. 5 1/2c
in 1000 ft. rolls per ft. 5c



Simpson Midgetester

An AC-DC volt-ohm-meter fits in shirt pocket. 10,000 ohms per volt AC and DC. Reads DC volts of 3 through 1200. AC volts 3 through 1200. DC resistances of 10,000, 100,000, 1 and 10 megohms. Comes with leads.

355 Volt-ohm-meter \$29.95

Model 260 Volt-Ohm-Milliammeter

Over 1/2 million in use. Has 29 ranges—20,000 ohms per volt DC and 1000 ohms per volt AC. Reads to 5000 volts AC or DC, 100UA, 10, 100, 500 MA and up to 20 megohms resistance. Also -12 to +55 decibels and output voltage to 250 volts AC. Comes with leads.

260 Simpson
Volt-Ohm-Milliammeter \$38.95



Vacuum Tube Voltmeter

Used as electronic DC voltmeter, ohmmeter, AC or AF voltmeter, RF voltmeter, output meter, etc. DC voltage ranges to 1200 volts. AC voltage ranges to 1200 volts. AF to 60 volts. Decibels -20 to +63. Resistance: in 5 ranges to 1000 megohms. For 105-125 volts 50/60 cycles.

303 Vacuum Tube Voltmeter \$68.00

ELECTRONIC VOLTAGE REGULATORS

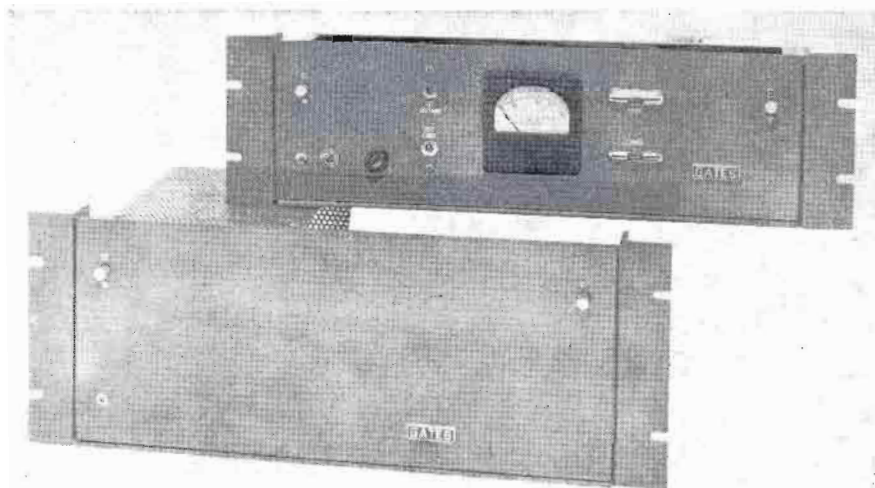

Available in ranges from 1 KVA to 70 KVA and in one or three phase systems. All models consist of two units: (1) the rack or cabinet type electronic control unit requiring only 5 1/4" x 19" of panel space, and (2) the rack or cabinet model motor driven variable transformer in 1 KVA or 2 KVA sizes. Sizes over 2 KVA have the motor driven variable transformer on a channel iron base as illustrated below. As the electronic voltage regulator is a device to move forward or backward a motor driven variable transformer, there is no problem in wave form, distortion such as often accompanies many types of regulators. Likewise the speed of voltage reset is fast enough for excellent operation with varying loads such as a Class B modulator. In addition, lesser than maximum loads will in no way upset either the regulation or wave form.

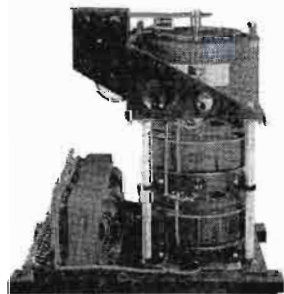

For powers above 2 KVA. The motor driven variable transformer is channel mounted allowing use of the regulation transformer near the load, even though the electronic regulator may be several hundred feet away.

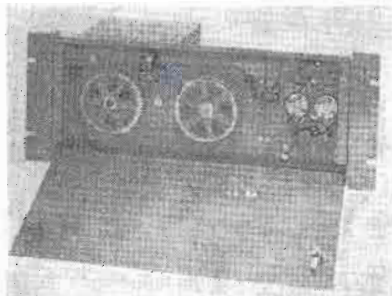

Front panel drop down view of the 1 KVA or 2 KVA models. These models will hold within ± 1 volt at any load up to maximum where input voltages vary $\pm 20\%$. Ideal for rack or smaller installations for TV, radio and hundreds of industrial applications.

ELECTRONIC VOLTAGE REGULATORS



Front of rack mount M-5294 electronic regulator control panel.



Front panel of M-5294 electronic regulator drops down so all components can be reached.



Rear M-5294 electronic regulator. There are no external components other than the motor driven variable transformer unit.

For all power ratings the M-5294 electronic control unit is identical, always consuming only 5¼"x19" of rack space, or approximately 7"x21"x10" if cabinet type is for wall mounting. The electronic regulator may be adjacent or several hundred feet from the motor driven variable transformer. Six interconnecting wires are required between the two units—no larger than 16 AWG regardless of distance.

Models for 115 and 230 volts, as well as single and 3 phase are available. All models are rated for either 50 or 60 cycles.

Outstanding feature of all models is the absolute regulation regardless of load conditions. As the electronic regulator actually operates from the output of the regulated supply, it is continually seeking to find the correct voltage if the load is full or zero. Though adjustment may be made for regulation as close as ± 1 volt, the regulator may be adjusted for lesser tolerances if the applied load is not that critical. In this case the operation of the motor unit is less frequent, reducing wear.

Principle of operation is by no means complex, yet extremely positive. The electronic control section operates from the output voltage present at the load point of the motor driven variable transformer. This, in turn, is adjusted by the electronic control unit M-5294 (above) to be independent of the current consumed by the load. Control tube is a sharp cut-off pentode which has a large change in plate current in ratio to grid voltage. This tube, with other circuit components and tubes, operates sensitive relays of about 1 MA current. These relays handle the forward/reverse action of the motor driving the variable transformer. — The operator may adjust from the front panel of the M-5294 regulator, the exact output voltage desired. For example, a 230 volt model may be set for 208 volts output and maintain regulation at this point.

The experienced engineer is well acquainted with the need for proper line voltages. For industrial applications the need is so great that even suggesting applications would consume pages. For radio and television broadcasting, the lack of uniform voltages at many critical points of both studio and transmitter operation may disrupt or greatly impair transmission.

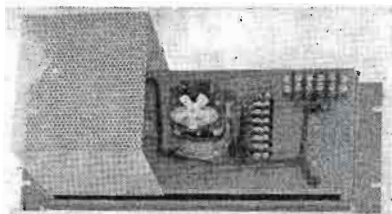

Rear of M-5295 rack mount motor driven variable transformer unit. M-5314, 2 KVA model is identical. Rack space is only 7"x19" or total for M-5294 electronic regulator and 1 or 2 KVA variable transformer unit is only 12¼" x 19" of rack space.

(Continued next page)

ELECTRONIC VOLTAGE REGULATORS

SPECIFICATIONS

SIZE: M-5294 regulator; rack model, 5 1/4" x 19" x 8 1/2" deep.
 M-5294A cabinet model regulator, 5 1/2" x 19" x 10" deep.
 M-5295 complete 1 KVA regulator, 12 1/4" x 19" x 8 1/2" deep.
 M-5295A complete 1 KVA cabinet model, 14" x 21" x 10" deep.
 M-5314 complete 2 KVA regulator, 12 1/4" x 19" x 8 1/2" deep.
 M-5314A complete 2 KVA cabinet model, 14" x 21" x 10" deep.

NOTE: Models 6 KVA and above have channel base mounting of motor driven variable transformers. Sizes vary as to power rating.

REGULATION: ±20% variation of input voltage will allow constant output voltage as close as ±1%, regardless of load.

TUBES: 6X4, 12AT7, 6AU6.

FINISH: Medium gloss gray.

Ordering Information

115 Volt, 50/60 Cycle Automatic Voltage Regulators, Single Phase

Cat.	Rating	Style	Price
M-5295	1 KVA	Rack Mounted	\$ 285.00
M-5295A	1 KVA	With Wall Mounted Control Unit	306.00
M-5314	2 KVA	Rack Mounted	334.00
M-5314A	2 KVA	With Wall Mounted Control Unit	355.00
M-5315	6 KVA	With Rack Mounted Control Unit	434.00
M-5315A	6 KVA	With Wall Mounted Control Unit	455.00
M-5316	15 KVA	With Rack Mounted Control Unit	642.00
M-5316A	15 KVA	With Wall Mounted Control Unit	663.00

230 Volt, 50/60 Cycle Automatic Voltage Regulators, Single Phase

M-5317	2.4 KVA	Rack Mounted	\$ 340.00
M-5317A	2.4 KVA	With Wall Mounted Control Unit	361.00
M-5318	7.5 KVA	With Rack Mounted Control Unit	481.00
M-5318A	7.5 KVA	With Wall Mounted Control Unit	502.00
M-5319	27.5 KVA	With Rack Mounted Control Unit	740.00
M-5319A	27.5 KVA	With Wall Mounted Control Unit	761.00

230 Volt, 50/60 Cycle Automatic Voltage Regulators, Three Phase

M-5320	10 KVA	With Rack Mounted Control Unit	\$ 817.50
M-5320A	10 KVA	With Wall Mounted Control Unit	838.50
M-5321	20 KVA	With Rack Mounted Control Unit	948.50
M-5321A	20 KVA	With Wall Mounted Control Unit	969.50
M-5322	45 KVA	With Rack Mounted Control Unit	1455.00
M-5322A	45 KVA	With Wall Mounted Control Unit	1476.00
M-5323	70 KVA	With Rack Mounted Control Unit	1840.00
M-5323A	70 KVA	With Wall Mounted Control Unit	1861.00

NOTE: For voltages higher than 230 volts, prices on application.

ANDREW COAXIAL CABLE

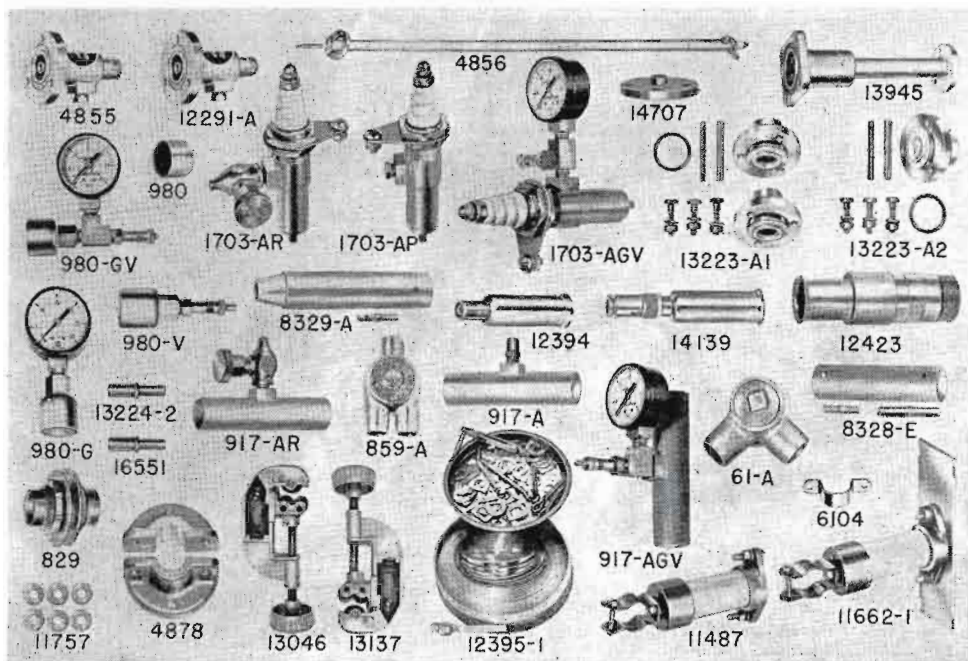

Listed on this and following pages are popular items of coaxial cable. Coaxial equipment involves many special items. Gates, through the national distribution arrangement with the Andrew Corporation, can supply any item, whether listed or not. — As coaxial cable is largely copper, prices will vary upward or downward as the daily copper market varies. Prices shown are believed accurate, but are subject to prices in effect on day of shipment.

7/8" Coaxial Cables and Fittings

740	7/8" diameter cable, 50 ohm, flanged	\$15.00 + \$1.35/ft.
5450	7/8" diameter cable, 50 ohm, no flanges	1.35/ft.
737	7/8" diameter cable, 64 ohm, no flanges	1.40/ft.
	Shipping reel deposit (refundable on prepaid return)	50.00
4855	Adapter, UHF jack for RG-8/U cable; to 7/8" flange for type 740 line	11.00
12291A	Adapter has type N jack for RG-8/U; other end 7/8" flange to type 740 line	11.00
13945	Adapter, type 740 to 1 5/8" type 451 line	28.00
13223A-2	Spare swivel flange with hardware	6.00
13223A-1	Two spare swivel flanges with hardware	9.75
14707	Flange cover, gas-tight, with 1/8" IPS hole and plug	1.00

Accessories for S450 Line

1703AGV	End terminal, gauge and valve	11.25
1703-AP	End terminal, gas release plug	9.50
1703-AR	End terminal, release valve	11.25

GATES

275

ANDREW COAXIAL CABLE

980	Cable cap for pressurizing during shipment	1.10
980GV	Cable cap, gauge and valve	6.00
980G	Cable cap with gauge	4.75
980-V	Cable cap with valve	2.90
8329A	Adapter, S450 to type 83 ($\frac{3}{8}$ " line)	5.00
12394	Adapter, UHF jack, to end terminal on S450	7.00
14139	Adapter, type N jack, attaches to end terminal on S450, includes type N plug	8.00
12423	Adapter, LC jack, attaches to end terminal on S450	17.50

Accessories for 740, S450 Line

8328E	Connector for splicing line	2.50
61A	Junction box, right angle	5.00
859A	Junction box, Tee	15.00
917AGV	Connector with gauge and valve	8.25
917AR	Connector with release valve	8.25
917A	Connector with gas inlet	5.75
13244-2	Adapter for inner conductor, S450, 740 cable	2.50
16551	Adapter, same as 13244-2 except solder type	2.00
829	Collar clamp, solders to cable	3.25
4878	Split collar clamp, solderless	3.75
11757	Insulator beads	2.50 per hundred
13046	Tubing cutter for splicing	3.15
13137	Grooving tool	5.50
12395-1	Wraplock, stainless steel	12.50
11487	Mounting clamp, insulated, bolts to tower	3.75
11662-1	Mounting clamp, insulated. Attaches with wraplock	5.50
6104	Mounting strap15

1 $\frac{5}{8}$ " VHF Transmission Line—Type 451

451	20 ft. section flanged both ends	60.00
451-1	20 ft. section flanged one end only	55.00
451-2	20 ft. section, no end flanges	50.00
1051M	Right angle mitered elbow, with universal swivel flanges	40.00
1051M-2	Right angle mitered elbow, unflanged	30.00
1151M	45 degree mitered elbow, with swivel flanges	40.00
1151M-2	45 degree mitered elbow, unflanged	30.00
T1251	Gas barrier for connecting pressurized section of 451 to flanged unpressurized section	40.00
T1851	Adapter for connecting type 451 to type 452 ($3\frac{1}{8}$ ")	44.00
13945	Adapter, $\frac{7}{8}$ " flange one end, $1\frac{5}{8}$ " flange on other end	28.00
13942	Adapter, has type N jack on one end, flange for $1\frac{5}{8}$ " line on other end, gas barrier and removable gas vent plug	46.50
4874	Adapter, $1\frac{5}{8}$ " flange one end, connects directly to RG-17U cable	20.00
T4837	Clamp connector, unpressurized, provides flange for cut end of type 451	7.50
14485	Swivel flange kit, includes fixed and rotating rings, silver solder preform, and flux	4.70

Semi-Flexible (70 ohm) $\frac{3}{8}$ " Line

83	Coaxial cable, $\frac{3}{8}$ " diameter, semi-flexible. Cut to order. Specify end fittings which attached at factory, no charge60 per ft.
	Shipping reel deposit (refundable when returned prepaid)	50.00
1701GV	End terminal with gas inlet and pressure gauge	11.50
1701P	End terminal with removable exhaust plug	8.50
1701R	End terminal with needle valve for gas release	10.00

Andrew Heliax 50 Ohm 7/8" and 1 5/8" Line

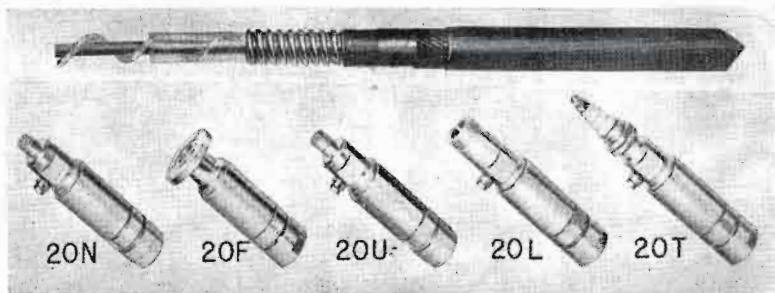

- H0** Coaxial cable, 7/8" diameter, cut to order. Specify end fittings. Can be attached at factory at no charge 1.50/ft.
- H1** Coaxial cable, 1 5/8" diameter, cut to order. End fittings can be attached at factory at no charge 3.40/ft.

Fittings for H0 Cable

- 20-F** 7/8" flange termination, fixed 7/8" flange 15.00
- 20-N** Type N termination. Has Type N receptacle (UG-58A/U), mates to UG-21B/U plug 23.00
- 20-U** Type UHF termination. Has Type UHF receptacle (SO-239), mates to PL-259A plug 23.00
- 20-L** Has Type LC receptacle (UG-352/U), mates to UG-154/U plug 32.00
- 20-T** End terminal. Used for AM installations 21.50

Fittings for H1 Cable

- 21-F** 1 5/8" flange termination 26.00
- 21-N** Type N termination. Has type N receptacle (UG-58A/U), mates to UG-21B/U plug 40.00
- 21-L** Type LC termination 49.00

NOTE: 21 Series fittings resemble 20 Series illustrated above



Automatic Dehydrator

Use with all size lines up to 6 1/8". Will handle 40,000' of 7/8", 10,000' of 1 5/8", 2500' of 3 1/8" and 700' of 6 1/8" cable.

Model 1910 \$450.00

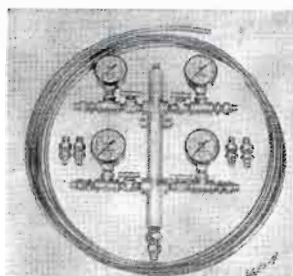

Gas Distribution Manifold

Includes pressure gauges, needle valves, 15' of 1/4" copper tubing for each outlet. State number of outlets required.

Model 6600 \$13.00
Plus \$6.00 for each outlet

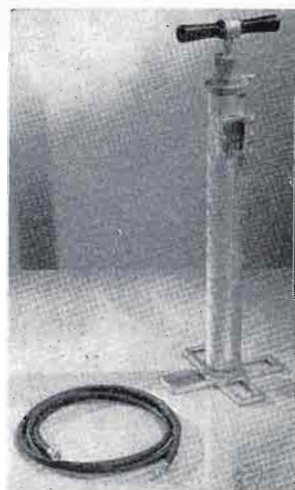

Dry Air Pump

Comes with 8' hose and silica gel fill.

Model 878 \$40.00

GATES

SOLID DIELECTRIC CABLE --- TOOLS

RG Solid Dielectric Coaxial Cable

An. No.	Cat. Number	Impedance	Wire Size	Outside Diam.	Price per foot	
					100'-499'	500'-999'
RG-8U	21-004	51	7/21	.285	\$.147	\$.143
RG-9U	21-005	51	7/21	.280	.313	.31
RG-11U	21-007	75	7/26	.285	.137	.132
RG12U	21-008	75	7/26	.285	.26	.257
RG-17U	21-013	51	.188	.680	.667	.658
RG-19U	21-015	51	.250	.910	1.037	1.028
RG-22U	21-038	95	Two 7/.0152	.285	.178	.173
RG-22A/U	21-148	95	Two 7/.0152	.285	.283	.278
RG58U	21-024	53	No. 20	.116	.06	.058
RG58A/U	21-199	51	No. 19	.116	.062	.058
RG59/U	21-025	73	22CW	.146	.07	.066
—	21-125	71	No. 9	.680	.603	.593

NOTE: Where necessary to ship RG cable on reels, a reel charge of \$50.00 per reel will be made and is wholly refundable when returned prepaid.

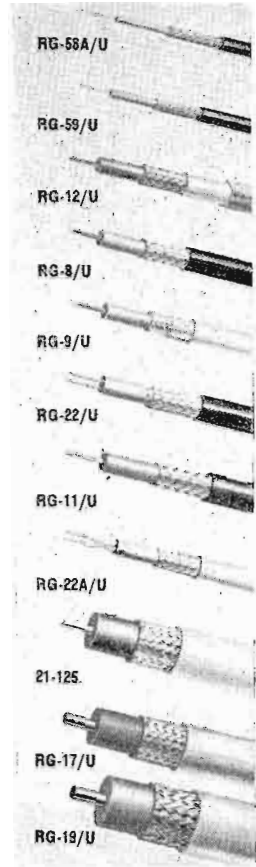

American Beauty Soldering Irons

No. 3128, for production and maintenance in radio, TV and switchboard work, 60 watts, 1/4" tip.

Each \$3.67

No. 3138, heavier iron with 3/8" tip, 100 watts.

Each \$5.83

No. 3158, large size, 200 watts, 1 1/8" tip.

Each \$6.83



Wen "Quick Hot" Soldering Iron

No. 100, heats in 2 1/2 seconds. Built-in spotlight. Ideal for emergency repairs where fast heating iron required.

\$5.95 each

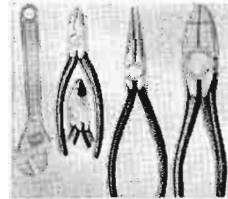

Pliers—Wrenches

Each

No. 91—4" adjustable thin jaw wrench	\$1.25
No. V-41—5" wire stripping side cutters	2.01
No. V-43—6" wire stripping side cutters	2.28
No. 226P—6 1/2" long nose pliers	1.65
No. 259P—7" side cutting pliers	2.40



Multi-Purpose Tool Set

No. PR99, all purpose socket wrench, Phillips head and screw-driver kit. In plastic case.

Each \$7.20

OPEN WIRE TRANSMISSION LINE

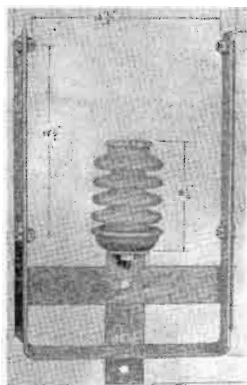

M-3327 Bracket

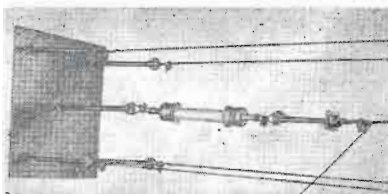

M-3328 End Plate



M-3322 Horn Gap

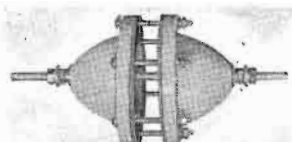

M-2870D Feed-thru Bowl



M-3864 Center Post

Transmission Line Bracket

For 5 or 6 wire transmission line. Rating up to 150KW modulated. See sketch on next page for impedance and installation detail. Made of 1/4" steel 3" wide with welded L section on each side to fully prevent twisting under ice or wind load. Supplied with 8 1/4" ribbed insulator, wire guides and all hardware. Galvanized throughout.

M-3327 Line Bracket \$31.50

Line End Plate

To terminate the open wire line at each end. Plate is 1/4" thick, 20" square. Fully galvanized. Includes turnbuckles, 25 1/2" strain insulator and all hardware. Rating up to 150KW modulated.

M-3328 End Plate \$38.00

Center Post Assembly

Has variety of uses such as end or corner angling of transmission line, support insulator for two wire line or rhombic antennas, and a guide insulator such as end of building or coupling unit. Rating 150KW. Galvanized throughout.

M-3864 Center Post Insulator \$8.50

Hard Drawn Wire

If desired, when ordering transmission line components, Gates will gladly supply No. 6, 8 or 10 hard drawn copper wire at current market prices. State length in feet desired, remembering to multiply the length of line by the number of wires in line, either 5 or 6.

Horn Gap

A very desirable item where higher power is employed. Connects to hot side of line and ground to drain off lightning and heavy static discharges. Usually one is employed for each 200' of line. Insulator for 150KW arc gaps heavy chrome plate. Galvanized throughout.

M-3322 Horn Gap \$48.00

Feed-Thru Bowls

A large feed-thru bowl with 50KW modulated rating. Available in single and double units and with solid or hollow studs as listed below. Bowls are Alsimag. Hardware heavy brass. Velutex seals are provided for weather-tight installation.

M-2870D Solid stud, 2 bowls, for walls to 10 1/2" thick \$9.00

M-3254 Same as above but hollow stud. 9.00

M-5280 Solid stud, single bowl, for walls 1" thick 7.50

M-5281 Same as above but hollow stud. 7.50

Special Open Wire Lines

Gates engineers have designed many special open wire lines for both short and long distances. Most celebrated was a 30-mile line supplied for use in the Arctic Circle. Upon receipt of a sketch or word description of the requirements, Gates engineers will gladly submit layout and quotation.

Open Wire Design and Impedance Chart

Chart below illustrates typical five or six wire open type transmission line. Table is provided to show impedances with various wire sizes at certain heights above ground. Transmission line brackets may be either M-3327 or M-2856, end plate either M-2857 or M-3328. Horn gap is M-3322. The power, lighting and telephone circuits shown are optional, according to requirements of installation. Open wire line will average about the same per foot cost as $\frac{1}{8}$ " coaxial cable.

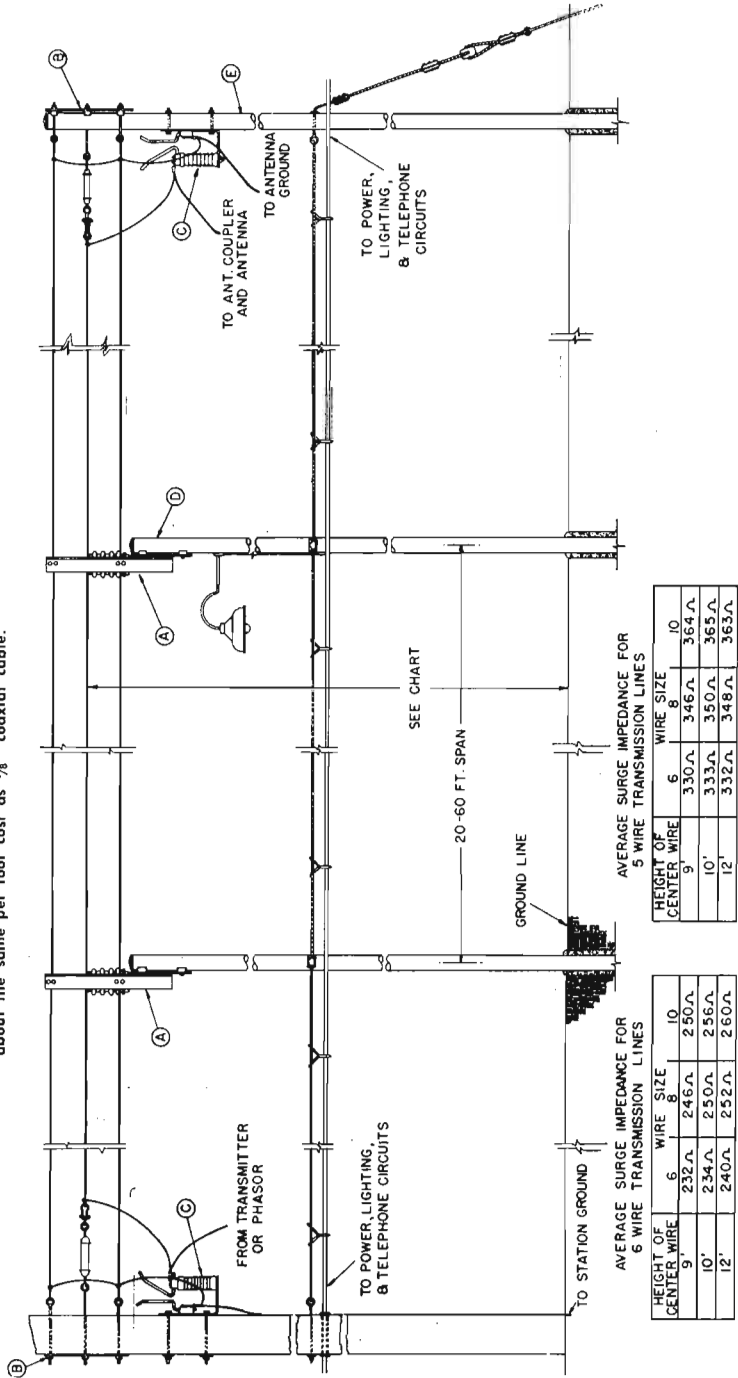

Hughey & Phillips Tower Lighting Equipment



300 MM Code Beacon

Fully approved for use with red color filters as a marker light for obstruction to air navigation such as TV, radio, microwave, etc. Constructed of heavy cast aluminum and completely weatherproof. Has ventilated dome, concave base with drain port, hinged center frame and color filters have supports covered with woven asbestos to provide heat insulation. Supplied with 2 red filters. Clear, green and yellow filters available where specified.

KG-114-3 Beacon for 3/4" conduit	\$243.55
KG-114-4 Beacon for 1" conduit	243.55
620PS40 Beacon lamp, 620 watts	2.25



Obstruction Light (bottom entrance)

Accommodates either 100 or 111 watts medium screw base lamp. Bottom entrance conduit fitting type in order to install on vertical conduit stubs. Fully approved.

OB20-3 for 3/4" conduit...	\$11.80
OB20-4 for 1" conduit...	11.80

Obstruction Light (side entrance)

This model has side entrance for conduit fitting. Holds 100 or 111 watt medium screw base lamps. Side entrance type for installation to horizontal conduit stubs. Fully approved.

OB21-3 for 3/4" conduit	\$11.80
OB21-4 for 1" conduit	11.80



Double Obstruction Lamp

Uses 2 approved red fresnel type lens. Holds 2 either 100 or 111 watt medium screw type lamps. Lens holding base assembly detaches easily to insert wiring. Bottom entrance type. OB22 TR-4 has transfer relay in base of fixture allowing automatic transfer in case of burn-out.

OB22-4 for 1" conduit	\$23.60
OB22 TR-4 for 1" conduit	31.20

Beacon Flashers

All electro-mechanical device for outdoor mounting to provide intermittent source of power meeting FCC and CAB regulations. Waterproof. Consists of single pole mercury tilt switch and synchronous motor gear reduced. Rated 2500 watts lamp load. Model BF32 has fail-safe provision. For 117 volts, single circuit type.

BF31 Flasher	\$60.00
BF32 Flasher	83.80

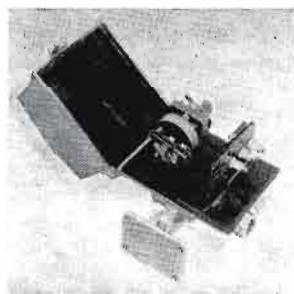

Waterproof flasher for outdoor mounting.

1 and 2 Circuit Flashers

New single and two circuit flashers in 3 models for outdoor, indoor and panel mounting. Same general specifications as those above. Fully approved. Rating 2800 watts.

<u>Cat. No.</u>	<u>Style</u>	<u>Mtg.</u>	<u>Price</u>
BF40	5. circuit 117V	outdoor	\$60.00
BF40	5. circuit 117V	indoor	56.50
BF40	5. circuit 117V	panel	49.40
BF41	2 circuit 117V	outdoor	80.00
BF41	2 circuit 117V	indoor	75.30
BF41	2 circuit 117V	panel	69.45

NOTE: BF41 may be had in 115/230 volts by adding \$1.20 to any model and ordering type BF42.

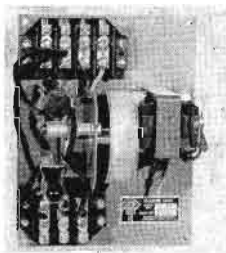

Panel flasher for mounting inside doghouse or coupler housing.

TOWER LIGHTING EQUIPMENT

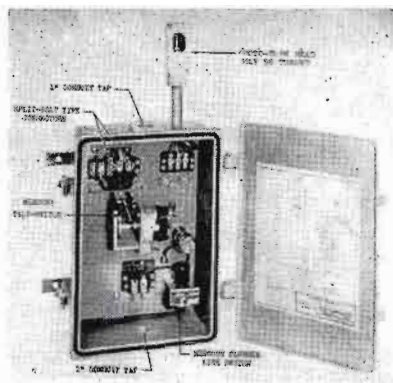

Photo-Cell and Beacon Flasher

A combination photo-electric unit for turning on-off tower lights plus a 30 per minute flasher. In weatherproof housing. Photo-cell head may be rotated to north regardless of mounting position on tower. Photo-electric unit turns on at 35-foot candles and off at 58-foot candles. Fully approved.

Cat. No.	Line Switch	Flasher Circuits	Price
LC-2074	1 pole 30 A.	one	\$190.00
LC-2072	1 pole 30 A.	two	210.00
LC-2073	2 poles 30 A. each	two	230.00

Fischer-Pierce Photo-Cell Unit

Completely weatherproof and fully approved photo-cell unit for turning on and off tower lights. Has time delay of 5-7 seconds to prevent operating lights by chance exposure such as walking in front of unit. Normal expected life of tubes is 20,000 hours. Mounting centers 8 1/4". Depth 6".

63305C for 105-130 volts, 3000 watt rating and for S. pole, S. throw, double break	\$55.00
63306C for 210-250 volts, 3000 watt rating and for S. pole, S. throw, double break	55.00

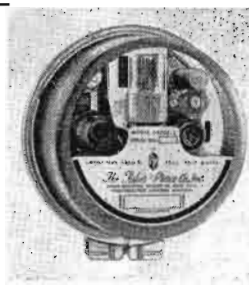

Replacement Lamps

100A21-T5 100 watt obstruction	...\$.37
111A21-T5 111 watt obstruction42
500P540 500 watt beacon	2.00
620P540 620 watt beacon	2.25

Tower Lighting Complete Kit

Due to the large variety of tower lighting kits, no listing of complete kits is shown. Complete kits are available for any size tower and Gates will be glad to provide an immediate quotation. As the listing of various lights, photo-cell and flasher units allows assembly of complete lighting kits other than wire, often purchased locally, it is felt that the purchaser may easily and economically handle his requirements from this catalog listing.

Replacement Parts for Hughey & Phillips Units

Part No.	Description	Price	Part No.	Description	Price
KG-114 (300 mm code beacon)			Obstruction (side) lights		
GL2030	Filter, red color	\$22.00	OB10E-3, OB10E-4, OB10M-3, OB10M-4, OB11M-4		
PK2020	Gasket, hinge ring	1.00	OB10-2	Holder, globe	3.40
PK2021	Gasket, lower section	.90	PK2039	Gasket, globe holder	.22
PK2019	Gasket, upper section	.80	GL2040	Globe, red fresnel	7.75
PK2018	Gasket, vent mounting	.60	XL2044	Receptacle, lamp (Mult)	.40
1 set	8 gaskets for 300 mm code beacon	7.60	Beacon Flasher		
WC2029	Insulated cable, interior harness	2.75	MB1086	Motor	10.80
GL2034	Lens, dome	25.00	SW1044	Switch, mercury-tilt (beacon)	4.31
GL2036	Lens, lower	32.00	SW1029	Switch, mercury-tilt (relay)	2.15
GL2035	Lens, upper	36.00	KR1027	Relay tube, thermal time delay	4.00
XL2025	Receptacle, pre-focus	5.40		Relay tube, thermal time delay	8.75
PK2026	Retainer ring, gasket (lower)	3.48		Gasket, housing	.75
PK2022	Retainer ring, gasket (upper)	3.48	KR1060	Relay, emergency	7.10
AC2017	Support, color filter	2.00	Photo-Electric Control		
PK2037	Woven asbestos fin tubing (for AC2017)	.75	PECA-2, 3, 4		
TB2027	Terminal block (3 term.)	1.32		Gasket, window	.11
				Gasket, housing	1.13
				Potentiometer, 2000 ohm	3.17
				Transformer, filament	3.93
				Relay, mercury	16.65
				Relay, plunger only	12.75
				Relay, coil only	4.35

STROMBERG-CARLSON PA EQUIPMENT



6 Watt Amplifier

Accommodates one Hi-Z mic and Hi-Z phono. Output 4, 8, 15 ohms. Gain 103 db. Response 75-8500 cps. Has controls for mic, phono, treble and on-off. 6 watts at 5% dist. or less.

AU-29 Amplifier\$56.25
AC-29 Cover 4.20

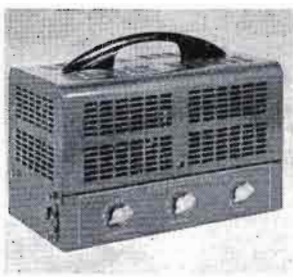

15 Watt Amplifier

Has provision for Hi-Z mic and phono. Output, 4, 8, 15 and 500 ohms. Gain 111 db. Response 50-10,000 cps. Controls, mic, phono, treble and on-off. 15 watts at 5% or less dist.

AC-42 Amplifier
and cover\$86.25



25 Watt Amplifier

Four Hi-Z mic inputs. One input with slotted shaft switch to adjust to phono input of all standard curves. Output, 4, 8, 16, 500 ohms. Gain 121 db. Controls, 4 inputs, treble, bass, on-off. 25 watts at 3% or less dist. Response 20-20,000 cps.

AU-57 Amplifier
with cover\$168.75



50 Watt Amplifier

Three Hi-Z mics, one phono at all standard curves. Output, 4, 8, 15, 250, 500 ohms. Response 50-12,000 cps. Gain 118 db. Consists of two 25 watt output channels with separate master gains so that system may be divided. Controls, 3 mic, one phono, treble, bass, two gain controls and on-off. Power output, 50 watts or 25 watts per channel at 5% or less dist.

AU-35 Amplifier
with cover\$206.25

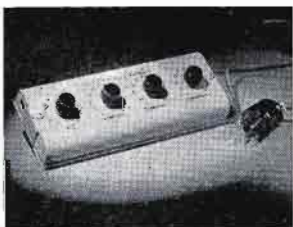

Remote Volume Control

Provides individual control of volume of each of four input sources. Designed for use with AU-57 amplifier listed on this page. Used for controlling volume from remote point such as orchestra pit. Size: 7½" long, 3" wide, 1" deep.

AK-13 Remote
Control\$14.25

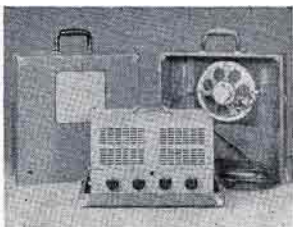

Portable Carrying Case

Comes with two loudspeakers, 25' cables and holds AU-57 amplifier. Heavily built plywood construction covered with fine grain, forest pine green Fabrikoid. Metal corner plates add to strength. Includes cable wind-up brackets. Size: 18½" high, 17" wide, 11¼" deep overall. Weight, 20 lbs.

PC-17 Case with speakers,
less amplifier\$ 51.00
AU-57 Amplifier for above.. 168.75
Complete PC-17 and AU-57.. 219.75

Mic Input Transformer

For use with AU-57 amplifier to convert Hi-Z to low impedance of 150 ohms and 37.5 ohms. This allows use with all conventional 30/50 or 150/250 ohm microphones. Plugs into back of AU-57. Well shielded. 20-20,000 ohm response.

TM-8 Transformer\$16.69

Microphones—Loudspeakers

A wide variety of microphones and stands will be found on Pages 162 through 168. For loudspeakers of both indoor and outdoor type, see Pages 172, 173 and 174.

TALK-A-PHONE INTERCOM SYSTEMS



TALK-A-PHONE DE LUXE SYSTEMS

Master Selective Systems (Figs. 1 & 2)



A system consisting of one Master Station and one to ten Sub-Stations. Master Station can talk and listen to any one Sub-Station or with all simultaneously. Sub-Stations do not communicate with each other. Only the Master Station plugs into an electrical outlet. You may start with only one Master and one or two Sub-Stations and then add later when necessary. Installation of system has optional feature whereby Sub-Stations can be connected "privately," or "non-privately" and still originate calls to the Master under either application. Once a conversation has been initiated with a "non-private" system, persons at Sub-Stations need operate no controls and can reply from a distance. When the system is connected "privately," Master unit cannot "listen in" on Sub-Stations. However, they can reply when called, and also originate calls to the Master. Operates universally on 110-120 volts, AC-DC. U.L. Approved. The AC-5406 and AC-5411 Master Stations operate as above with the added feature of 10 times volume output. A desirable feature for large areas or noisy locations. Operates on 110-120 volts, AC only. Only one master station can be used in these systems.

- Model LM-5** Master Selective Station for 5 Sub-stations, complete with tubes and easy-to-follow instructions. Wt. 7 lbs. List Price each \$45.00. Net each **26.45**
- Model LM-10** Master Selective Station for 10 Sub-Stations, complete with tubes and easy-to-follow instructions. Wt. 7 lbs. List Price each \$58.00. Net each **34.00**
- Model LR-3** Sub-Station for use with LM-5 or LM-10 Masters. Wt. 5 lbs. List Price each \$15.95. Net each **9.35**
- Model LR-3M** Sub-Station in brown metal case. Wt. 3 lbs. List Price each \$15.95. Net each **9.35**
- Model AC-5406** Master Station, 5 sub-station capacity High Volume Output. Wt. 8 lbs. List Price each \$55.00. Net each **32.35**
- Model AC-5411** Master Station, 10 sub-station capacity High Volume Output. Wt. 8 lbs. List Price each \$68.00. Net each **39.95**
- Model AR-3** Sub-Station for use with AC-5406 or AC-5411 Masters. Wt. 5 lbs. List Price each \$16.95. Net each **9.95**
- Model AR-3M** Same as AR-3 above, but in brown metal case. Wt. 3 lbs. List Price each \$16.95. Net each **9.95**
- Model HP-3** Hi-Power Staff Station for wall mounting. Brown metal case. Wt. 8 lbs. List Price each \$25.00. Net each **14.70**
- Model C-20** Nine-Inch Weatherproof Re-Entrant Horn. Wt. 5 lbs. List Price each \$44.95. Net each **26.50**
- S-100** Wall Switch for origination of call through C-20 or HP-3. List Price each \$5.00. Net each **2.95**
- No. 5303** (3-conductor) Cable for connecting Sub-Stations to Master. List Price per foot 5c. Net per foot **.03**

Super Selective Systems (Fig. 2)



A system of all Master Stations. Any Station can call any other Station. Several completely private 2-way conversations are possible at same time. A versatile, low cost intercom system offering extreme flexibility, meeting many requirements in industry, offices, homes, etc. Any Station can call and carry on a conversation with any other Station in the system with absolute "privacy." Have a visitor in your office and your mind is at ease that no one can eavesdrop on your conversation. Stations can be located even 1000 feet apart. Variable volume, adjustable at each unit, controls incoming voice. You can start with two or three masters, and then add later as required. Operates universally on 110-120 volts, AC-DC. U.L. Approved.

- Model LS-5** Super Selective Station for five Masters, complete with tubes and easy-to-follow instructions. Wt. 7 lbs. List Price each \$45.00. Net each **26.45**
- Model LS-10** Super Selective Station for ten Masters, complete with tubes and easy-to-follow instructions. Wt. 7 lbs. List Price each \$58.00. Net each **34.00**
- No. 5506** (6-conductor) Cable for connecting LS-5 Masters. List Price per foot 13c. Net per foot **.07 1/2**
- No. 9911** (11-conductor) Cable for connecting LS-10 Masters. List Price per foot 24c. Net per foot **.14**

2—Station Inter-Communication Systems

(Figs. 1 & 3)

Provides voice communication between any two points. For homes, stores, offices, farms, etc. Ideal for nursery. No more getting up and down to see if baby is all right with "Elsie" on the job. "Elsie" is a packaged item, complete with a Master Station, a Sub-Station and 50 feet of interconnecting cable. Additional cable lengths are available for greater distances. "Elsie's" Sub-Station can optionally be operated "privately," so that the Master cannot listen in (but Sub-Station can answer calls and also originate calls), or "non-privately," allowing the Master to "listen in" and enabling persons at a distance from the Sub-Station to answer without operation of any controls. The volume can be adjusted from a bare whisper to the full output of the powerful high gain amplifier. Operates universally on 110-120 volts, AC-DC. All units are complete, ready to plug in. Walnut impact bakelite cabinets. Cabinets measure 8 1/4" x 6 3/4" x 7 1/2". Underwriters Laboratories Approved.

- Model LC-2** 2-Station System complete with tubes, easy-to-follow instructions, and 50 feet of cable. Wt. 11 lbs. List Price complete \$51.00. Net complete **29.95**
- No. 5303** (3-conductor) Cable. For use where additional lengths are required between the Master and the Sub-Station. List price per foot 5c. Net per foot **.03**

TYPES G1, G2, G3, G4 and G5 MICA CAPACITORS



SANGAMO Type G ceramic cased capacitors having dimensions and characteristics as specified for the Joint Army-Navy Standard Types CM-75, CM-80, CM-85, CM-90 and CM-95, are intended for service where highest voltage and R.F. current ratings are required, such as in commercial transmitting or induction heating applications. Current ratings of these sizes will be supplied upon request.

Catalog Number	Capacity Mfd.	Peak Wkg. Volts	Price
Type G1			
G1-641	.00001	6000	\$21.27
G1-645	.00005	6000	22.92
G1-631	.0001	6000	24.36
G1-632	.0002	6000	24.36
G1-634	.0004	6000	26.61
G1-635	.0005	6000	27.99
G1-621	.001	6000	27.99
G1-6215	.0015	6000	29.34
G1-622	.002	6000	29.34
G1-623	.003	6000	30.36
G1-624	.004	6000	30.36
G1-625	.005	6000	30.36
G1-526	.006	5000	30.87
G1-511	.01	5000	30.87
G1-4115	.015	4000	30.87
G1-312	.02	3000	30.87

Type G2			
G2-1031	.0001	10000	\$39.33
G2-10315	.00015	10000	39.33
G2-1032	.0002	10000	39.33
G2-10325	.00025	10000	39.33
G2-1035	.0005	10000	39.33
G2-1021	.001	10000	39.33
G2-10212	.0012	10000	39.33

Catalog Number	Capacity Mfd.	Peak Wkg. Volts	Price
G2-10215	.0015	10000	39.33
G2-1022	.002	10000	39.33
G2-823	.003	8000	39.33
G2-824	.004	8000	39.33
G2-525	.005	5000	39.33
G2-526	.006	5000	41.49
G2-511	.01	5000	41.49
G2-4115	.015	4000	41.49
G2-312	.02	3000	41.49

Type G3

G3-2045	.00005	20000	\$66.54
G3-2031	.0001	20000	72.60
G3-2032	.0002	20000	78.66
G3-20325	.00025	20000	78.66
G3-2033	.0003	20000	78.66
G3-2035	.0005	20000	82.29
G3-2038	.0008	20000	82.29
G3-2021	.001	20000	84.69
G3-15215	.0015	15000	85.92
G3-1522	.002	15000	85.92
G3-1523	.003	15000	90.75
G3-1524	.004	15000	90.75
G3-1025	.005	10000	90.75
G3-1026	.006	10000	90.75
G3-1028	.008	10000	90.75
G3-1011	.01	10000	90.75
G3-512	.02	5000	90.75
G3-313	.03	3000	90.75

Type G4

G4-3043	.00003	30000	\$100.74
G4-3045	.00005	30000	100.74
G4-3031	.0001	30000	126.18
G4-30315	.00015	30000	126.18
G4-30325	.00025	30000	132.69
G4-3035	.0005	30000	132.69
G4-3038	.0008	30000	132.69
G4-3021	.001	30000	137.46
G4-25215	.0015	25000	137.46
G4-2022	.002	20000	137.46
G4-2023	.003	20000	137.46
G4-2024	.004	20000	140.61
G4-1525	.005	15000	145.20
G4-1526	.006	15000	151.35
G4-1228	.008	12000	156.00
G4-1011	.01	10000	163.46
G4-612	.02	6000	163.46
G4-514	.04	5000	163.46

Type G5

G5-5045	.00005	50000	\$265.80
G5-3531	.0001	35000	278.40
G5-35325	.00025	35000	302.40
G5-3534	.0004	35000	302.40
G5-3535	.0005	35000	326.40
G5-3521	.001	35000	336.60
G5-3022	.002	30000	322.80
G5-30225	.0025	30000	328.80
G5-3023	.003	30000	340.80
G5-2525	.005	25000	340.80
G5-2026	.006	20000	340.80
G5-1511	.01	15000	340.80

Standard tolerance $\pm 5\%$, 3 characteristic.
For $\pm 2\%$ tolerance add 20% to list price.

GATES

TYPES F1, F2, and F3 MICA CAPACITORS

Catalog
Number Capacity
Mfd. Peak
Wkg. Volts

Type F1 Mica Capacitors

F1-341	.00001	3000	\$7.56
F1-345	.00005	3000	7.56
F1-331	.0001	3000	7.56
F1-3315	.00015	3000	7.56
F1-332	.0002	3000	7.56
F1-3325	.00025	3000	7.56
F1-333	.0003	3000	7.56
F1-334	.0004	3000	7.56
F1-335	.0005	3000	7.56
F1-336	.0006	3000	7.56
F1-3375	.00075	3000	7.56
F1-338	.0008	3000	7.56
F1-321	.001	3000	7.56
F1-3215	.0015	3000	7.56
F1-322	.002	3000	7.56
F1-3225	.0025	3000	7.56
F1-223	.003	3000	7.56
F1-224	.004	2000	7.56
F1-225	.005	2000	7.56
F1-226	.006	2000	7.56
F1-1528	.008	1500	7.56
F1-111	.01	1000	7.56
F1-112	.02	1000	8.58
F1-0215	.05	250	8.58
F1-0201	.1	250	9.08

Type F2 Mica Capacitors

F2-545	.00005	5000	\$10.38
F2-531	.0001	5000	10.38
F2-5315	.00015	5000	10.38
F2-532	.0002	5000	10.38
F2-5325	.00025	5000	10.38
F2-533	.0003	5000	10.38
F2-534	.0004	5000	10.38
F2-535	.0005	5000	10.38
F2-536	.0006	5000	10.38
F2-5375	.00075	5000	10.38
F2-538	.0008	5000	10.38
F2-521	.001	5000	10.38
F2-5215	.0015	5000	10.38
F2-522	.002	5000	10.38
F2-5225	.0025	5000	10.38
F2-523	.003	5000	10.38
F2-424	.004	4000	10.38
F2-325	.005	3000	10.38
F2-326	.006	3000	10.38
F2-328	.008	3000	10.38
F2-211	.01	2000	10.38
F2-2115	.015	2000	10.38
F2-212	.02	2000	10.38
F2-213	.03	2000	10.38
F2-1514	.04	1500	10.38
F2-1515	.05	1500	10.38
F2-0501	.1	500	11.52
F2-0202	.2	250	15.15
F2-02025	.25	250	16.74



TYPE F



TYPE E

Type F3 Mica Capacitors

F3-8325	.00025	8000	\$21.15
F3-835	.0005	8000	21.15
F3-821	.001	8000	23.55
F3-822	.002	8000	23.55
F3-825	.005	8000	29.16
F3-811	.01	8000	33.12
F3-415	.05	4000	37.11
F3-201	.1	2000	29.16
F3-06025	.25	600	26.76
F3-0605	.5	600	31.53
F3-0610	1.0	600	49.11

Standard tolerance $\pm 5\%$. B characteristic. For $\pm 2\%$ tolerance add 20% to list price.

TYPE E MICA CAPACITORS

Catalog Number	Capacity Mfd.	Test Volts D. C.	Price
E-1245	.00005	12500	\$ 6.60
E-1231	.0001	12500	6.60
E-12325	.00025	12500	6.60
E-1235	.0005	12500	6.60
E-1221	.001	12500	6.60
E-12215	.0015	12500	7.83
E-1222	.002	12500	9.00
E-1023	.003	10000	10.83
E-1024	.004	10000	11.43
E-1025	.005	10000	12.03
E-721	.001	7000	6.03
E-722	.002	7000	7.83
E-723	.003	7000	8.43
E-711	.01	7000	12.63
E-3524	.004	3500	8.43
E-3525	.005	3500	7.83
E-3511	.01	3500	12.03
E-3512	.02	3500	12.03
E-3515	.05	3500	13.83
E-215	.05	2000	12.03
E-201	.1	2000	13.83

Available in $\pm 20\%$ tolerance only.

HIGH VOLTAGE FILTER CAPACITORS

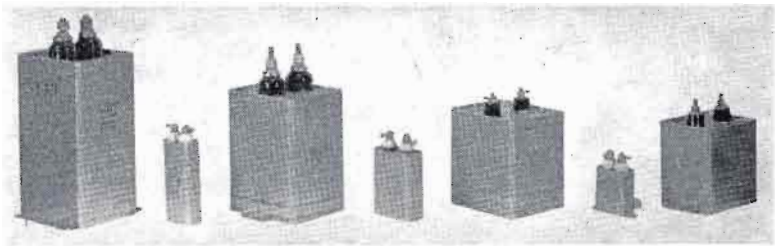

Capacitors listed below represent nearly all capacities normally employed. For higher than 7000 volts, please write for prices. As all capacitors are to RTMC standards, Gates will supply popular brand types but not restricted to any specific brand, unless brand preference is stated.

Type	Capacity	Price	Type	Capacity	Price
7106-2	2—600 volts DC	\$ 4.29	7130-4	4—3000 volts DC	\$22.11
7106-4	4—600 volts DC	5.46	7130-8	8—3000 volts DC	37.41
7106-8	8—600 volts DC	8.10	7140-2	2—4000 volts DC	28.05
7106-10	10—600 volts DC	9.09	7140-4	4—4000 volts DC	40.11
7110-2	2—1000 volts DC	4.95	7140-6	6—4000 volts DC	51.45
7110-4	4—1000 volts DC	6.27	7150-2	2—5000 volts DC	32.19
7110-8	8—1000 volts DC	9.09	7150-4	4—5000 volts DC	38.94
7110-10	10—1000 volts DC	10.08	7160-1	1—6000 volts DC	50.16
7120-2	2—2000 volts DC	6.45	7160-2	2—6000 volts DC	89.76
7120-4	4—2000 volts DC	9.09	7175-1	1—7000 volts DC	64.95
7120-8	8—2000 volts DC	15.03	7175-2	2—7000 volts DC	99.42
7120-10	10—2000 volts DC	18.33	TK70040	4—7000 volts DC	150.48
7130-2	2—3000 volts DC	15.03			

TYPE H MICA CAPACITORS

600 W.V.D.C.

Catalog Number	Capacity Mfd.	Price
H-T1450	.00005	\$0.72
H-T1310	.0001	.72
H-T1320	.0002	.72
H-T1325	.00025	.72
H-T1330	.0003	.72
H-T1340	.0004	.72
H-T1350	.0005	.72
H-T1210	.001	.72
H-T1215	.0015	.72
H-T1220	.002	.78
H-T1225	.0025	.78
H-T1230	.003	.87
H-T1240	.004	.90
H-T1250	.005	.93
H-T1260	.006	1.08
H-T1270	.007	1.11
H-T1280	.008	1.14
H-T1110	.01	1.29
H-K1115	.015	1.59
H-K1120	.02	1.83
H-K1125	.025	2.16
H-K1130	.03	2.67



1200 W.V.D.C.

H-T2450	.00005	\$0.96
H-T2310	.0001	.96
H-T2320	.0002	.96
H-T2325	.00025	.96
H-T2330	.0003	.96
H-T2340	.0004	.96
H-T2350	.0005	.96
H-T2210	.001	1.08
H-T2215	.0015	1.38
H-T2220	.002	1.44
H-T2225	.0025	1.68
H-T2230	.003	1.83
H-K2240	.004	1.83
H-K2250	.005	1.98
H-K2260	.006	1.98
H-K2280	.008	2.31
H-K2110	.01	3.06

2500 W.V.D.C.

H-T5450	.00005	\$1.14
H-T5310	.0001	1.14
H-T5320	.0002	1.14
H-T5325	.00025	1.32
H-T5330	.0003	1.35
H-T5340	.0004	1.38
H-T5350	.0005	1.44
H-T5210	.001	1.68
H-T5215	.0015	2.13
H-K5220	.002	2.49
H-K5230	.003	2.94
H-K5240	.004	3.39
H-K5250	.005	3.84

Standard tolerance $\pm 10\%$.

GATES

RECEIVING TUBES

General Electric tubes. A 10% discount is granted where 20 or more assorted receiving tubes are purchased at one time.

TYPE	PRICE	TYPE	PRICE	TYPE	PRICE	TYPE	PRICE
OZ4	.70	6A7	1.53	6BG6GA	2.60	6L6	2.35
OZ4A	1.00	6A8	1.55	6BH6	1.15	6L6G	1.83
OZ4G	.85	6AB4	.85	6BH8	1.53	6L6GA	1.83
1A5GT	1.05	6AB7/1853	1.60	6BJ6	1.03	6L6GB	1.83
1A7GT	1.23	6AC7/1852	1.55	6BJ7	1.18	6L7	1.45
1AH4	1.45	6AD7G	2.13	6BK5	1.38	6L7G	1.70
1AJ5	1.53	6AF4	1.70	6BK7A	1.45	6N7	1.63
1AX2	1.23	6AF4A	1.70	6BL7GT	1.73	6P7	1.33
1B3GT	1.23	6AG5	1.03	6BN6	1.35	6R7	1.40
1E4G	1.00	6AG7	1.83	6BQ6GA	1.88	6SA4	.90
1L4	1.08	6AH4GT	1.20	6BQ6GT	1.88	6SA7	1.15
1LA4	1.48	6AH6	1.95	6BQ7A	1.63	6SA7GT	.93
1L6	1.45	6AJ4	2.23	6BU5	2.75	6SB7Y	1.73
1LA6	1.38	6AK5	2.13	6BK7GT	1.68	6SC7	1.25
1LC5	1.38	6AK6	1.15	6BY5G	1.65	6SF5	1.03
1LC6	1.38	6AL5	.78	6BY6	1.00	6SF7	1.38
1LD5	1.38	6AL7GT	2.28	6BZ6	1.00	6SG7	1.30
1LE3	1.38	6AM4	2.23	6BZ7	1.70	6SH7	1.38
1LH4	1.38	6AM6	1.38	6C4	.75	6SJ7	1.08
1LN5	1.38	6AN8	1.48	6C5	1.00	6SK7	1.03
1N5GT	1.30	6AQ5	.98	6C5GT	1.08	6SK7GT	1.08
1R5	1.13	6AQ6	.85	6C6	1.40	6SL7GT	1.40
1S4	1.28	6AR5	1.03	6CA5	1.10	6SN7GTA	1.08
1S5	.95	6AS5	1.00	6CB6	1.00	6SN7GTB	1.08
1T4	1.08	6AS7G	4.50	6CD6G	2.48	6SQ7	.95
1T5GT	1.40	6AS7GA	4.50	6CD6GA	2.35	6SQ7GT	.95
1U4	1.05	6AT6	.75	6CF6	1.08	6SR7	1.03
1U5	.93	6AT8	1.38	6CG7	1.10	6T4	1.73
1V	1.28	6AU4GT	1.45	6CL6	1.55	6T8	1.45
1X2A	1.30	6AU5GT	1.73	6CN7	1.13	6U5	1.03
1X2B	1.30	6AU6	.93	6CM6	1.15	6U6GT	1.23
2A3	2.28	6AU8	1.53	6CR6	1.03	6U7G	1.20
3A4	1.25	6AV5GA	1.73	6CS6	1.00	6U8	1.43
3LF4	1.55	6AV6	.75	6D6	1.40	6V3A	1.95
3Q4	1.10	6AX4GT	1.18	6DE6	1.03	6V6	1.83
3Q5GT	1.40	6AX5GT	1.03	6E5	1.18	6V6GT	.90
3S4	1.08	6B4G	2.25	6F5	1.20	6W4GT	.98
3V4	1.08	6B5	1.75	6F6	1.23	6W6GT	1.20
5U4G	.85	6B6G	1.23	6F6G	1.00	6X4	.70
5U4GA	.88	6B7	1.75	6F6GT	1.00	6X5GT	.80
5U4GB	.88	6BA6	.90	6F8G	1.93	6X8	1.38
5V4G	1.28	6BA7	1.30	6G6G	1.53	6Y6G	1.30
5V4GA	1.28	6BC5	1.00	6H6	.93	7A4/XXL	1.03
5X4G	1.03	6BC7	1.60	6J5	.95	7A5	1.30
5Y3G	.70	6BC8	1.73	6J6	1.18	7A6	1.08
5Y3GT	.73	6BD6	.90	6J7	1.33	7A7	1.10
5Y4G	.93	6BE6	.95	6J7G	1.25	7A8	1.18
5Y4GT	.93	6BF5	1.03	6J7GT	1.40	7AF7	1.20
5Z3	1.20	6BF6	.80	6K6GT	.95		
5Z4	1.65	6BG6G	2.60	6K7	1.28		

RECEIVING TUBES

TRANSMITTING TUBES

TYPE	PRICE	TYPE	PRICE	TYPE	PRICE	TYPE	PRICE
7AG7	1.28	12BA6	.90	25W4GT	1.05	0A2	1.37
7AH7	1.23	12BA7	1.30	25W6GT	1.30	0A3/VR75	1.27
7AU7	1.13	12BD6	.90	25Z5	1.13	0A4G	1.60
7B4	1.00	12BE6	.95	25Z6GT	1.08	0B2	1.39
7B5	.95	12BF6	.80	35A5	1.13	0E3/VR90	1.47
7B6	1.13	12BH6	1.00	35B5	1.05	0C3/VR105	1.37
7B7	1.03	12BH7	1.28	35C5	.95	0D3/VR150	1.27
7B8	1.15	12BH7A	1.28	35L6GT	.98	0Z4A	1.00
7C4	1.83	12BK5	1.38	35Y4	.63	CLJ	9.60
7C5	1.08	12BN6	1.45	35Y4	.90	CLK	10.40
7C6	1.05	12BQ6GA	1.90	35Z3	.90	1P29	2.95
7C7	1.08	12BY7	1.33	35Z4GT	.78	1P39	1.75
7C8	1.33	12BY7A	1.35	35Z5GT	.73	2A1A	10.35
7B6	1.50	12BZ7	1.28	37	.93	2B1	11.00
7E7	1.68	12H6	1.10	41	1.15	2C39A	24.00
7F7	1.28	12J5	.95	42	1.08	2C39B	32.15
7F8	1.73	12J5GT	.93	45	1.13	2D21	1.85
7G7	1.50	12J7GT	1.40	45Z5GT	.90	2E24	4.65
7H7	1.25	12K7G	1.00	50A5	1.13	2E26	3.85
7J7	1.83	12K7GT	1.28	50B5	1.05	2E30	2.60
7K7	1.60	12L6GT	1.00	50C5	.95	2H21	100.00
7L7	1.45	12Q7GT	1.05	50L6GT	.98	3B1A	16.50
7M7	1.18	12SA7	1.18	50X6	1.13	3K3000IA	2,470.00
7Q7	1.30	12SA7GT	.93	50Y6GT	1.18	3K3000IQ	2,360.00
7R7	1.75	12SC7	1.25	59	1.93	3K20000LA	2,975.00
7S7	1.73	12SF5	1.08	70L7GT	3.48	3K20000LF	2,975.00
7T7	1.75	12SF5GT	1.08	75	1.00	3K20000LK	2,975.00
7W7	1.75	12SF7	1.38	76	.85	3K50000IA	4,200.00
7X7/XXFM	1.65	12SG7	1.30	80	.85	3K50000LF	4,200.00
7Y4	.90	12SH7	1.38	83	1.30	3K50000LK	4,200.00
7Z4	.90	12SJ7	1.08	83V	1.60	3K50000LQ	4,200.00
10Y	2.05	12SK7	1.08	84/6Z4	.93	3X2500A3	198.00
12A4	1.10	12SK7GT	.93	89	1.18	3X2500F3	198.00
12A8GT	1.45	12SL7GT	1.40	117Z3	.93	3X3000A1	198.00
12AL5	.83	12SN7GA	1.08	117Z6GT	1.58	3X3000F1	198.00
12AQ5	.95	12SQ7	.95	6660/6BA6	1.03	4-65A	20.00
12AT6	.75	12SQ7GT	.80	6661/6BH6	1.28	4-125A	30.25
12AT7	1.30	12V6GT	.93	6662/6BJ6	1.18	4-250A	41.25
12AU6	.90	12W6GT	1.20	6663/6AL5	.89	4-400A	60.50
12AU7	1.10	12X4	.70	6679/12AT7	1.43	4-1000A (Eimac)	132.00
12AU7-A	1.10	14A7	1.13	6680/12AU7	1.20	4-1000A (G.E.)	135.00
12AV5GA	1.73	14AF7/XXD	1.23	6681/12AX7	1.25	4E27A/5-125B	35.75
12AV6	.73	14B6	1.13			4W20000A	1850.00
12AV7	1.53	14B8	1.13			4X150A	38.95
12AW6	1.20	14C5	1.50			4X150D	38.95
12AX4GT	1.20	14Q7	1.30			4X150G	54.00
12AX4GTA	1.20	19T8	1.45			4X250B	42.50
12AX7	1.15	25BQ6GT	1.95			4X250F	42.50
12AZ7	1.30	25CD6GB	2.48			4X250M	54.00
12B4	1.20	25L6GT	.98			4X500A	121.00



Buy 20 assorted receiving tubes on one order - take 10% discount from receiving tube prices.

TRANSMITTING TUBES

PRICE	TYPE	TYPE	PRICE	TYPE	PRICE
4X500F	93.50	575A	21.00	*5751 (Proto 12AX7)	3.35
4X5000A	395.00	631	625.00	5763	1.93
5-125B	35.75	673	21.00	5771	543.00
5BFLA	22.50	678	47.00	5814A	3.25
5CP1A	27.00	750TL	137.50	5820	1200.00
5CP7A	31.40	802	5.15	*5840	8.87
5R4GY	1.89	805	13.50	*5840A	8.87
5R4GYA	1.89	807	2.50	5874	556.00
5R4GTY	1.89	809	4.20	5879	1.75
6AN5	3.65	810	16.25	5881	3.50
6AS6	3.43	811A	5.00	*5896A	8.50
6AS7G	4.50	812A	5.00	*5899A	10.95
6AS7GA	4.50	813	18.00	*5902A	12.60
6D4	2.35	814	14.25	*5915A	1.45
6J4	6.22	815	12.35	5917	218.00
7C23	173.00	816	1.65	5918	950.00
7C25	160.00	828	15.00	5919	1250.00
7C25A	160.00	829B	16.25	5996	195.00
7C26	230.00	832A	12.90	*6005 (Proto 6AQ5)	3.55
7D21	320.00	833A	49.50	6009	204.00
8C25	576.00	836	9.00	*6021A	11.05
9C23	490.00	837	5.80	*6072 (Proto 12AY7)	4.55
9C28	1050.00	838	13.75	6080	6.00
9C29	1505.00	845	13.75	*6087 (Proto 5Y3GT)	5.25
9C30	1110.00	857B	218.50	*6111A	12.55
9C31	1460.00	862-A	1322.00	*6112A	12.20
35T	12.00	866A	2.45	*6134 (Proto 6AC7)	5.45
35TG	16.00	872A	8.20	*6135 (Proto 6C4)	1.90
KT66	3.50	880	510.00	*6136 (Proto 6AU6)	2.20
100TH	18.25	884	1.85	*6137 (Proto 6SK7)	2.20
100TL	18.25	885	2.00	6146	4.90
110X	650.00	891	237.00	6179	1035.00
124-A	996.00	F-891R (Federal)	385.00	6201 (Proto 12AT7)	4.15
124R	1357.00	GL-891R	381.00	6202 (Proto 6X4)	3.17
125-A	1035.00	(General Electric)		*6203	3.97
127-A	120.00	892-A	237.00	*6265 (Proto 6BH6)	4.00
128-A	184.00	F-892R (Federal)	385.00	6366	160.00
129-B	345.00	GL-892R	381.00	6367	185.00
129-R	370.00	(General Electric)		*6386	7.15
132-A	230.00	893-A	664.00	6660/6BA6	2.05
134	2700.00	893A-R	1212.00	6661/6BH6	2.55
212E	104.00	898-A	1322.00	6662/6BJ6	2.30
220C/320B	365.00	1000T	137.50	5516	7.95
220CA/320BA	430.00	1500T	220.00	5642	2.60
242C	15.50	1612	3.00	*5654 (Proto-6AK5)	2.90
249B	9.00	1614	2.55	5658	510.00
250TH	33.00	1616	8.65	5662	3.20
250TL	33.00	1620	6.25	5663	1.90
304TL	60.50	1621	1.95	5666	225.00
315A	38.60	1622	2.50	5667	302.50
342-A	582.00	1624	4.00	*5670 (Proto 2C51)	4.85
343-A	350.00	1625	2.65	5680	185.00
343-AA	435.00	1850A	565.00	*5718A	6.85
450TH	77.00	2000T	275.00	*5719A	6.85
502A	1.95	2050	1.85		

*Denotes General Electric Five Star

Record Changers --- Tuners --- Miscellaneous

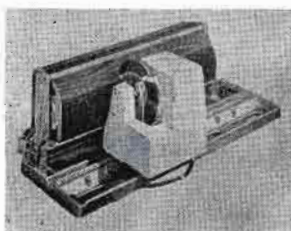
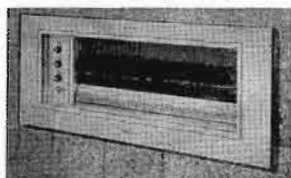

Seeburg Select-O-Matic

With the advent of automatic programming, this unit with other tape equipment and special control equipment now developed by Gates, is considered the most remarkable ever developed for automatic operation. Holds 100 45 RPM records and is completely selective. Has diamond stylus, self-contained preamplifier and 500 ohm output. Each Seeburg Select-O-Matic is modified at the Gates factory for adaptation to broadcast automatic programming. — Gates will gladly work out complete systems to fit budget requirements. — Pictures show mechanism which is available in wall and desk cabinets. — Size of desk cabinet (not illustrated) 16 1/2" x 38 1/2" x 17 1/2" deep. Size of wall cabinet (illustrated) 16 3/16" x 38 1/2" x 17 3/8" deep.

Model SO-1 Modified, in cabinet \$735.00
 Model SO-2 Modified, wall mount 689.00



Hi-Fi AM/FM Tuner

Frequency response: FM, 20 to 20,000 cps at less than 1% total harmonic distortion . . . temperature compensated oscillator circuits prevent drift on both FM and AM . . . geared tuning condenser and expanded tuning scale assure ease of control . . . only three controls . . . Tuning, Band Selector, and Volume . . . no duplication of tone controls . . . sensitivity: 1.5 microvolts for 20 db quieting . . . 2 position selectivity control on AM . . . Automatic Frequency Control provided. Size: 5 3/4" high, 12 1/8" wide, 9 3/4" deep. Stromberg-Carlson.

SR-402 Tuner \$150.00



Bogen Preamplifier-Mixer

For microphone mixing in high quality PA work. Self-contained power supply. Four mic and one phono inputs plus master gain and bass-normal-treble control. Plug-in transformers, listed below, convert to Low-Z input. JOH has Hi-Z output and no output meter. JOL has 50/200/500 ohms output and includes meter. Size: 15 1/4" wide, 8" high, 11" deep. Has 7 tubes.

JOH Mixer \$ 79.65
 JOL Mixer 103.20
 T155 Plug-in 200 ohm trans. 9.00
 T156 Plug-in 500 ohm trans. 12.00
 T157 Plug-in 50 ohm trans... 12.00

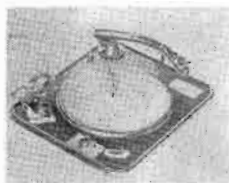

Garrard Record Changer

Perhaps the best in 3-speed, modestly priced changers. Plays 7, 10 and 12 inch discs. Heavy duty, 4 pole constant speed motor. Rim drive. Adjustable stylus pressure. Mutes during record change. Accommodates minimum of 12 discs, more of thinner types. For pickup heads use RPX-050A or RPX-053A listed Page 141.

RC-80 Changer complete, less pickup head and 45 RPM spindle \$49.50
 45 RPM Spindle 3.50
 W-80 Wood base for table mounting RC-80 5.95

Dummy Antennas

Air cooled. Illustrated is 5KW model; 100% modulated or 10KW unmodulated. 1KW models do not have dust cover. May be used for any power lower than rated. Resistance change under modulation is negligible.



DU-551 5KW Dummy Antenna, 51 ohms \$125.00
 DU-570 5KW Dummy Antenna, 70 ohms 140.00
 DU-151 1KW Dummy Antenna, 51 ohms 75.00
 DU-170 1KW Dummy Antenna, 70 ohms 75.00

GROUND WIRE, STRAP, RODS, SCREEN

Carried in stock are large quantities of No. 10 soft drawn copper ground wire, 2" and 4" strap, 6' and 8' copperweld ground rods and 8'x24' copper 3/4" mesh around screen. As price of copper varies daily by reason of copper market fluctuations, Gates will supply at lowest market price at day of billing. — These products always in stock.



3X2500

Tube Socket

For use with 3X2500F3 and 3X3000F3. Size: 8 1/8" high, 4 3/4" diameter. Quantity prices on application.

M-3934
 Tube Socket
 \$39.50

Meter Shorting Switch

A DPDT 15 ampere shorting switch to take RF ammeters out of circuit for lightning protection. Silver plated contacts. Mounting centers 1 3/4" x 4 1/2". Size: 5 1/2" x 5 1/2" x 2 1/4". Supplied with insulators, as illustrated.

M-3863 Switch \$23.75



METERS

Gates carries thousands of meters of all types, including VU, antenna, milliammeters, voltmeters, hours consumed meters and many others in 2", 3" and 4" size. Fast action on emergencies.

TRANSFORMERS

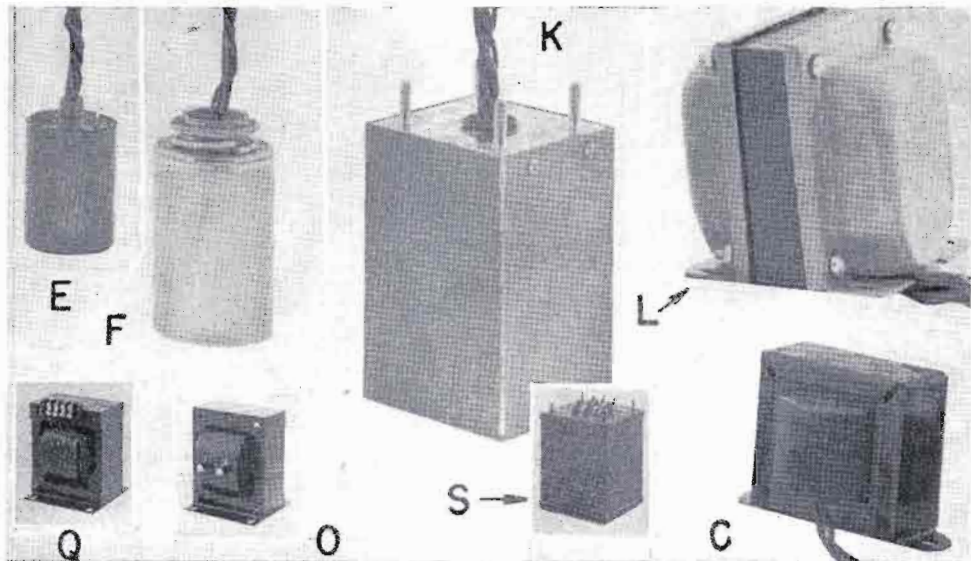

Legend: For easy reading, primary and secondary windings of audio transformers will show a letter, such as "A". These are defined below, to indicate impedance.

A = 50, 125, 200, 250, 335, 500, 600 ohms

B = 150/50 ohms

C = 600/150 ohms

D = 60,000 ohms single grid

E = 115 volts, 50/60 cycles

F = Quadruple shield equal to 90 Db.

G = Triple shield, equal to 75 Db. Rotates to 90 Db.

H = Dual shield, electrostatic shield, equal to 60 Db.

I = 45 Db. shielding

All transformers are commercial grade, continuous duty, broadcast type. Audio transformers are linear standard, low phase shift design to meet rigid response and distortion specifications as set forth both in F.C.C. and accepted Engineering Standards.

INPUT TRANSFORMERS		
Cat. No.	Description	Price
A1-3002U	Pri. A, Sec. 120,000 ohms P.P. or single grids. Shielding F. Case round, chassis mount, lug terminal. 3-1/4" high, 2-1/2" deep.	\$48.00
A1-10379T	Pri. B, Sec. D, Shielding G. Case style F. Size 1-3/4" high, 1-5/16" diam. Max. level, 0 Dbm.	16.50
A1-10386T	Pri. C, Sec. D, Shielding C. Case style F. Size 1-3/4" high, 1-5/16" diam. Max. level, 0 Dbm.	15.75
A1-10426T	Pri. B, Sec. C. Case E. Size 1-5/16" high, 1" diam. Max. level, -10 Dbm.	12.00
OUTPUT TRANSFORMERS		
AO-10864T	Pri. 10,000 ohms, 15 MA in winding. Sec. C, Shielding I. Also 10% ter. winding on Sec. Size 2" wide, 2-3/4" high, 1-5/8" high. Max. level, +22 Dbm. Case J.	18.20

AO-10427T Pri. 15,000 ohms, no DC in winding. Sec. C, Shielding I. Size 1" diam., 1-5/16" high. Case E. Max. level, +8 Dbm. 12.25

PCO-150A Pri. P.P. PLTS, 12,000 ohms CT at 200 MA. Sec. C + 16, 8, 4 ohms. Level 15 watts and 10% Sec. ter. winding. Size 4-3/4" high, 4" wide, 3-1/4" deep. Wire leads out of base. 7.50

REPEATER TRANSFORMERS

114A Audio line to line. Fully cased. Top or bottom mtg. Pri. A, Sec. A. Max. level, +16 Dbm. 20-20,000 cycles. 75 Db. shielding. 19.50

LOW VOLTAGE POWER TRANSFORMERS

R3A Pri. E, Sec. 1, 500V CT at 20 MA. Sec. 2, 6.3V CT at 2A. Size 2-3/4" high, 2-3/8" wide, 2-5/8" deep. Has low density case for pre and remote amplifier usage. Case L. 4.05

AP-10462K Plate trans. Pri. 230V 50/60 cy. Sec. 760/550-0-550/760V at 250 MA. For use with 2, 5R4GY rectifiers with fil. trans. AF-10463K (below) to produce 475 or 600V DC (choke input) at 250 MA. Base terminals. Case S. 44.25

AF-10463K Fil. trans. Pri. 230V 50/60 cy. Sec. 1, 5.1V at 4.0A. Sec. 2, 5.1V at 2A. Base terminals. Case S. 18.25

AP-11231T Pri. E, Sec. 1, 720V CT at 175 MA. Sec. 2, 5V at 2A. Sec. 3, 6.3V CT at 8A. Sec. 4, 6.3V CT at 2.7A. Size 4" high, 3-1/4" wide, 4-3/4" deep. Case L. For regulated or quality audio power supply. 25.90

AP-10232T Pri. E, Sec. 1, 550V CT at 90 MA. Sec. 2, 6.3V CT at 3.5A. Sec. 3, 5V at 2A. Low density case for low noise. Size 3-1/2" high, 3" wide, 3-3/8" deep. Case L. 18.60

LOW VOLTAGE FILTER CHOKES

C1X 15 hy. at 20 MA. Res. 1000 ohms. Size 1-3/16" high, 2-1/8" wide, 1-3/4" deep. Case C. 1.20

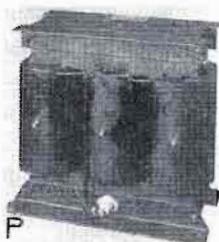

Transformers

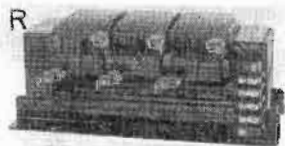

L. V. FIL. CHOKES (cont'd)	
C3X	10 hy. at 50 MA. Res. 500 ohms. Size 1-11/16" high, 2-3/4" wide, 1-1/2" deep. Case C. 1.32
C7X	10 hy. at 90 MA. Res. 220 ohms. Size 2" high, 3-1/4" wide, 2" deep. Case C. 1.92
C12X	6 hy. at 160 MA. Res. 165 ohms. Size 2-1/4" high, 3-13/16" wide, 2-1/4" deep. Case C. 2.70
MODULATION TRANSFORMERS	
BM-1	For 250W transmitters. Pri. Class B P.P. 810. Sec. 4000 ohms. Size 6-1/8" wide, 5-1/4" deep, 7-1/16" high. 37.50
AM-10464E	For 1000W transmitters. Pri. Class B 833A. Sec. 4750 ohms. Case style M. Stud terminals on side. 210.00
AM-3161M	For 1000W transmitters. P.P. Class B 833A. Sec. 5000 ohms. Fully cased with ceramic bushings out of side. 290.00
AM-10649E	For 500W transmitters. P.P. Class B 833A. Sec. 7500 ohms. Case style M. Stud terminals on side. 136.00
AM-7718E	Pri. P.P. 3X2500A3 or F3 tubes. Sec. 3600 ohms. For 5000W transmitters. Case style M. Dry type. Use with AC-7719M reactor. 900.00
AM-7718M	Pri. P.P. 2X2500A3 or F3 tubes. Sec. 3600 ohms. For 5000W transmitters. Case style N. Oil filled. Use with AC-7719E reactor. May be used indoor or outdoor. 1450.00
AM-3167E	For 10KW transmitters. Pri. P.P. 3X2500A3 or F3 tubes. Sec. 1780 ohms. Case style M. Dry type. Use with AC-3168E reactor. 1350.00
AM-3167M	For 10KW transmitters. Pri. for P.P. 3X2500A3 or F3 tubes. Sec. 1780 ohms. Case style N. Oil filled, indoor or outdoor type. Use with reactor AC-3168M. 1960.00
MODULATION REACTORS	
BR-1	For 250W transmitters. 65 hy. 250 MA. Square case, terminals out of top. Use with BM-1 mod. trans. 57.30
AC-10650E	For 500W transmitters. 50 hy. 325 MA. 225 ohms res. Case M. Use with AM-10649E mod. trans. 99.00
AC-10465E	For 1KW transmitters. 45 hy. 600 MA. Case M. Use with AM-10464E mod. trans. 157.00
AC-3135M	For 1000W transmitters. 49 hy. at 650 MA. Fully cased, ceramic bushings out of side. Use with AM-3161M mod. trans. 234.00
AC-7719E	For 5KW transmitters. 30 hy. at 1.4 amp. Case style M. Stud terminals, dry type. Use with AM-7718E mod. trans. 700.00
AC-7719M	For 5KW transmitters. 52 hy. at 1.4 amp. Case style N. Oil filled, indoor or outdoor type. Use with AM-7718M mod. trans. 1175.00
AC-3168E	For 10KW transmitters. 26 hy. at 2.8 amp. Dry type. Case style M. Use with AM-3167E mod. trans. 900.00
AC-3168M	For 10KW transmitters. 26 hy. at 2.8 amp. Oil filled, indoor or outdoor type. Case style N. Use with AM-3167M mod. trans. 1525.00
DRIVER TRANSFORMERS	
BD-1	For 250W transmitters. Pri. P.P. 6L6, 1622, etc. Sec. Class B 810 tubes. Chassis mtg. Lug terminals. 20.70
AS-3158C	For 1KW transmitters. P.P. 845 tubes to Class B 833A. Screw terminals. 71.10
AS-3172C	For 5KW and 10KW transmitters. Pri. P.P. Par. 845. Sec. P.P. Class B 3X2500A3 or F3. 86.10
POWER TRANSFORMERS	
AP-7235E	For 250W. Pri. 215/230/245V 50/60 cy. Sec. 1700-0-1700V to supply 0.85A with 2, 8008 or 872A rectifiers in full wave. Case M. 121.00
AP-10651E	For 500W. Pri. 230V 50/60 cy. Sec. 3100-0-3100V to supply 0.65A with 2, 8008 or 872A rectifiers in full wave. Case M. 132.00
AP-10459E	For 1KW. Pri. 230V 50/60 cy. Sec. 3100-0-3100V. To deliver 2600V DC at 1A when used with 2, 8008 or 872A rectifiers. Case M. 176.00
AP-3077M	For 1KW. Pri. 205, 215, 230, 245V 50/60 cy. Sec. 3100/1500-0-1500/3100V. Delivers 1.1A at 2600V DC and 0.4A at 1400V DC when used with 2, 575A and 2, 8008 rectifier tubes, respectively. Fully cased, ceramic bushings out of side. 254.00
AP-8000E	For 5KW. Pri. 218/230/242 50/60 cy, 3 ph. delta. Sec. 2160 per leg Y. Supplies 2.3A at 5000V when used with 6, 8008 or 872A rectifiers full wave. Dry type. Case M. 550.00
AP-8000M	For 5KW. Pri. 230V 50/60 cy, 3 ph. delta. Sec. 2160 per leg Y. To deliver 5000V DC at 2.25A when used with 6, 8008 or 872A rectifiers full wave. Oil filled, indoor or outdoor. Case N. 795.00

TRANSFORMERS --- TAPE RECORDERS

PWR. TRANSFORMERS (cont'd)

AP-3090E For 10KW. Pri. 230V 50/60 cy, 3 ph. delta. Sec. tapped to deliver in Y circuit, 5000, 5250, 5500V DC at 4.5A when used with 6, 673 tubes full wave. Dry type. Case P. 850.00

AP-3090M For 10KW. Pri. 230V 50/60 cy, 3 ph. delta. Sec. Y connected delivers 5000V DC at 4.5A when used with 6, 673 tubes full wave. Oil filled, indoor or outdoor type. Case N. 1245.60

POWER FILTER REACTORS

CG-109 For 250 or 500 watts. Swing-choke. 5-25 hy. at 500 MA, 52 ohms res., 7000V ins. Round case, base terminals. 25.00

CG-105 For 250 or 500 watts. Smoothing choke. 5-25 hy. at 300 MA, 90 ohms res., 5000V ins. Round case, base terminals. 14.00

AC-10458E For 1KW. Swinging choke. 5-16 hy. at 1.5A. DC res. 30 ohms. 10KV ins. Case M. 132.00

AC-10457E For 500W or 1000W. 2-1/2 hy. at 700 MA. 20 ohms DC res. 10KV ins. Case O. 36.30

AC-3141E 8 hy. at 1.0 amp. 38 ohms res. Case M. All purpose high current choke coil. Insulation 4000V. 79.20

AC-3143E For 5KW input and smoothing. For 10KW smoothing. 4 hy. at 1.5A, 17 ohms res., 8000V RMS ins. Case M. 85.80

AC-3147E For 10KW input. 2 hy. at 3A. 6.4 ohms res. 18KV ins. Case M. 190.00

FILAMENT TRANSFORMERS

AF-7782E For one 3X2500A3 or F3. Pri. 215/230/245V 50/60 cy. Sec. 7.8V CT at 51A. Case Q. 54.00

AF-10433E Rec. fil. trans. for four 8008, 872A tubes or two 673 tubes. Two Sec. windings of 5V CT at 16A. Pri. 230V 50/60 cy. Case R. 50.60

AF-10434E For three 3X2500A3 or F3. Pri. 215/230/245V 50/60 cy. Three secondaries, each 7.8V CT at 51A. Case R. 106.00

AF-10432E Rec. fil. trans. Has six separate Sec. windings of 5V CT at 10A for 8008, 872A, 673 rectifiers. Pri. 215/230/245V 50/60 cy. For full wave 3 ph. H.V. rectifier. Case K. 83.60

AF-10456K Rec. fil. trans. Two 8008 or 872A tubes. Pri. 230V 50/60 cy. Sec. 5.1V CT at 15A. Ins. 10KV. Base terminals. Case S. 28.00

AF-10460K Fil. trans. for 2, 833A plus a 6.3V 5-1/2 amp. winding. Pri. 230V 50/60 cy. Sec. 1, 10.2V CT at 20A. Sec. 2, 6.4V CT at 5-1/2A. Base terminals. Case S. 32.90

OTHER TRANSFORMERS

The transformer listing on these pages is typical only. Actually, Gates carries hundreds of varied types of transformers in stock and can provide the smallest audio input or a 50KW transformer. — Gates branches carry UTC transformers of nearly all types and immediate shipment can be made to any part of the country. — As transmitter designs, AM, FM and TV, require many styles of transformers not ordinarily found in jobber catalogs, Gates wants its customers to know that any of these transformers are available for either construction or emergency requirements regardless of whether the equipment is Gates or another make.

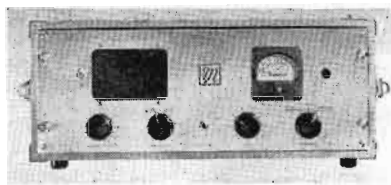

New Magnecord PT6 Series

Just released by Magnecord and too late to place in tape recorder section. Improved PT6 series follows illustrious earlier PT6 series that have made world-wide sales records. — Available in portable or rack models.

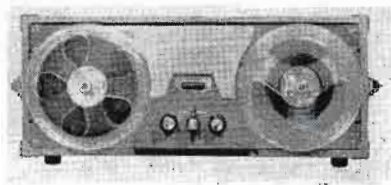

PT6-55A RECORDER, left, electrically interchangeable with older PT6 models. Improved all the way including 2-speed motor, tape lifter, plastic head cover, neon record indicator plus wider response and still lower distortion. Use with PT6-55J amplifier below. Full-track standard. If half-track desired, please specify.

PT655A Portable case model\$365.00
PT6-55AX Rack model (7"x19") 340.00

PT6-55J AMPLIFIER, combination record-playback amplifier with self-contained speaker and 10W output. Includes cables to attach to recorder. Electrically interchanges with older PT6 series. Input for 50/250 ohm mic and bridging for off-the-line recording. Output, 250/600 ohms to line plus 10 watts for speakers.

PT6-55J Portable case model\$260.00
PT6-55JX Rack model (7"x19") 240.00

93x28 REEL EXTENSION arm kit to modify
PT6-55 for 10 1/2" reels\$49.00

GATES INDUCTORS

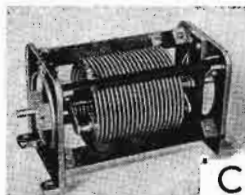
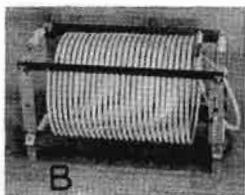
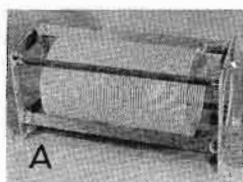

Used in both Gates and many other makes of transmitters and phasing equipment. Variable coils have cast aluminum end bells with double gripping bronze bearing wheels. All types are micalex insulated and silver plated.

LEGEND:

- FA = Fixed 1/4" edgewise, 10 amp. rating, Fig. A
- FB = Fixed 3/8" edgewise, 15 amp. rating, Fig. A
- FC = Fixed 1/2" edgewise, 20 amp. rating, Fig. A
- FBO = Fixed 3/8" copper tubing, 30 amp. rating, Fig. B
- FCO = Fixed 1/2" copper tubing, 40 amp. rating, Fig. B
- VB = Variable 3/8" edgewise, 15 amp. rating, Fig. C
- VC = Variable 1/2" edgewise, 20 amp. rating, Fig. C

Cat. No.	Ind. mh.	Length	Diam.	Price
87FA4634	87	12"	4"	\$24.25
6FBO854	6	5-1/4"	4"	16.55
10FBO855	10	5-1/4"	5"	17.50
13FBO856	13	5-1/4"	6"	21.75
18FB1754	18	8-3/4"	4"	19.65
26FB1755	26	8-3/4"	5"	20.50
35FB1756	35	8-3/4"	6"	17.85
58FB2845	58	10-1/2"	5"	27.85
78FB2846	78	10-1/2"	6"	28.35
128FB4635	128	12-1/8"	5"	29.70
6FCO854	6	6-1/4"	4"	18.35
10FCO855	10	6-1/4"	5"	20.00
13FCO856	13	6-1/4"	6"	21.75
17FC1654	17	8-3/4"	4"	24.00
24FC1655	24	8-3/4"	5"	25.50
32FC1656	32	8-3/4"	6"	29.10
42FC2266	42	12-1/4"	6"	29.80
67FC2856	67	13-1/8"	6"	34.05
78FC2658	78	13-1/8"	7"	45.90
32FBT1658	32	15"	8"	39.70
45FBT2158	45	18-1/2"	8"	50.75
65FBT2559	65	22"	9"	59.50
17FCT1178	17	14"	8"	40.90
35FCT1179-C	35	24-1/2"	9"	66.90

VARIABLE COILS

16VB1544	16	9-1/8"	4-5/8"	41.95
30VB2344	30	11-1/8"	4-5/8"	50.25
105VB3735	105	12-1/2"	7"	55.00
6VCO854	60	8"	5"	37.35
15VC1444	15	9"	5"	43.65
26VC2144	26	11-3/4"	5"	52.75

CLIPS

LC4	For 1/4" edgewise FA coils	.24
LC6	For 3/8" edgewise FB coils	.36
LC8	For 1/2" edgewise FC coils	.65
RC6	For 3/8" tubing FBO coils	1.65
RC8	For 1/2" tubing FCO coils	1.89

DIAL FOR VARIABLE COIL

M3401A	Veeder counter geared type, reads to 1/10 turn. 1/4" diam. shaft. Fig. D.	14.00
--------	---	-------

FIXED ATTENUATOR DATA

The table below gives the correct resistance values for "T", "H", balanced "H" and "O" type pads. The audio circuit will, in most cases, demand the type of pad to be used. For example, in an unbalanced circuit a "T" pad should be used. In a balanced circuit an "H" or an "O" pad, and in a circuit balanced to ground, a balanced "H" pad should be employed. In constructing these pads good quality accurate resistors are desirable.

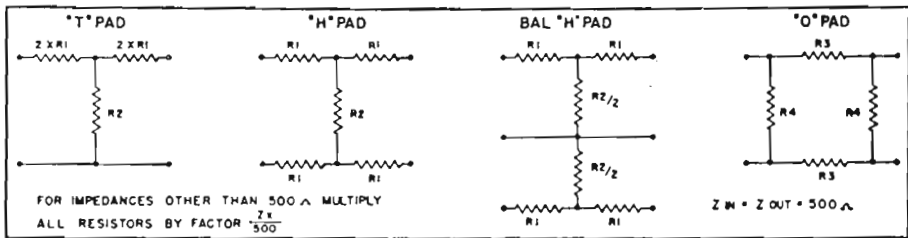

Loss in DB	R1	R2	R3	R4
0.1	1.440	43420	2.879	86850
0.2	2.878	21720	5.755	43440
0.3	4.318	14480	8.635	28950
0.4	5.758	10850	11.52	21710
0.5	7.193	8685.	14.40	17380
0.6	8.635	7232.	17.29	14480
0.7	10.07	6198.	20.17	12420
0.8	11.51	5421.	23.06	10870
0.9	12.95	4818.	25.95	9656.
1.0	14.38	4333.	28.85	8690.
2.0	28.65	2152.	58.08	4364.
3.0	42.75	1420.	88.08	2925.
4.0	56.58	1049.	119.3	2209.
5.0	70.03	822.4	152.0	1785.
6.0	83.08	669.4	186.8	1505.
7.0	95.65	558.0	224.0	1308.
8.0	107.7	473.1	264.3	1162.
9.0	119.1	405.9	308.0	1050.
10.0	129.9	351.3	355.8	962.5
15.0	174.5	183.6	680.8	756.3
20.0	204.5	101.0	1238.	611.2
25.0	223.5	56.40	2216.	559.5
30.0	234.7	31.65	3949.	532.7
35.0	241.3	17.79	7027.	518.0
40.0	245.1	10.00	12500	510.1

FREQUENCY RELATED TO TOWER HEIGHT

This guide shows typical tower heights related to operating frequency. $\frac{1}{4}$ wave tower height is shown and is that usually employed. For $\frac{3}{8}$ wave tower height, multiply tower height shown by $1\frac{1}{2}$, and for $\frac{1}{2}$ wave multiply tower height shown by 2.

Freq.	Tower in ft.	Freq.	Tower in ft.	Freq.	Tower in ft.
550	446.8	900	273.0	1260	195.2
560	439.5	910	270.6	1270	193.6
570	431.3	920	267.3	1280	192.2
580	423.9	930	264.8	1290	190.7
590	417.3	940	261.5		
		950	259.1	1300	189.2
600	410.0	960	256.6	1310	187.7
610	403.1	970	253.3	1320	186.5
620	396.8	980	250.9	1330	184.9
630	390.3	990	248.4	1340	183.6
640	386.5			1350	182.2
650	378.8	1000	246.0	1360	180.5
660	373.1	1010	243.7	1370	179.5
670	367.3	1020	241.1	1380	178.1
680	361.1	1030	238.8	1390	176.5
690	356.2	1040	236.5		
		1050	234.2	1400	175.6
700	351.2	1060	232.0	1410	174.2
710	346.8	1070	229.9	1420	173.4
720	341.9	1080	227.7	1430	172.0
730	337.0	1090	225.6	1440	170.9
740	332.1			1450	169.6
750	328.0	1100	223.6	1460	168.5
760	323.4	1110	221.6	1470	167.3
770	319.8	1120	219.7	1480	166.5
780	315.7	1130	217.7	1490	165.0
790	311.6	1140	215.6		
		1150	213.9	1500	164.0
800	307.5	1160	211.9	1510	162.9
810	303.4	1170	210.2	1520	161.7
820	300.1	1180	208.6	1530	160.8
830	296.0	1190	206.7	1540	159.9
840	292.7			1550	158.6
850	289.4	1200	205.0	1560	157.8
860	286.1	1210	203.2	1570	156.7
870	282.9	1220	201.5	1580	155.8
880	279.6	1230	199.7	1590	154.7
890	276.3	1240	198.4		
		1250	196.8	1600	153.7

Summary of Frequencies Used by the Broadcast Services

FREQUENCY OR BAND	USE	EXCLUSIVE TO BROADCAST SERVICE		
535-1605 Kc	107 AM Channels	Yes		
1606 Kc 1622 Kc	Remote Pickup Broadcast	Yes		
1628 Kc				
1646 Kc	Motion Picture Radio Service (Base and Mobile Stations)	No		
1652 Kc 2292 Kc 2398 Kc 4637.5 Kc	Remote Pickup Broadcast	Yes		
26.11-26.47 Mc			19 Remote Pickup B/c Stations	Yes
27.255 Mc			Citizens Radio Service — Radio Control only	No
49.70-49.82 Mc			4 Motion Picture Radio Service Stations—Base and Mobile	No
54-72 Mc	TV Channels 2-4	Yes		
72-76 Mc	78 Motion Picture Radio Serv. Operational and Fixed Stations	No		
76-88 Mc	TV Channels 5 & 6	Yes		
88-92 Mc	20 Non-commercial FM Channels	Yes		
92-108 Mc	80 Commercial FM Channels	Yes—except in Hawaii where the 98-108 Mc portion is assigned to Fixed Services and is not used for FM Broadcast.		
152.87-153.35 Mc	9 Remote Pickup B/c Stns.	No—shared with Indust. Services which have first priority of use.		
152.87-152.99 Mc	3 Motion Picture Radio Service Stations—Base and Mobile	No		
166.25 Mc 170.15 Mc	Remote Pickup Broadcast	No—Government stations operating on these two frequencies must be protected.		
173.225-173.375 Mc				
174-216 Mc	4 Motion Picture Radio Service Stations—Base and Mobile	No		
174-216 Mc	TV Channels 7-13	Yes		
450-451 Mc 455-456 Mc	20 Remote Pickup B/c Stns.	Yes		
460-470 Mc				
460-470 Mc	Citizens Radio Service Class A and B Stations	No		
470-890 Mc	TV Channels 14-83	Yes		
890-911 Mc	41 TV Sound Channels	No — experimental stations are allowed to operate in this band.		
925-940 Mc	29 AM STL Stations	No — experimental stations are allowed to operate in this band.		
940-952 Mc	23 FM STL Stations	Yes		
1990-2110 Mc	7 TV Pickup/STL/Inter-city Relay Stations	Yes		
2450-2500 Mc	3 TV Pickup/STL/Inter-city Relay Stations	No — must accept interference from I-S-M services. Also used by Fixed and Mobile Services.		
6875-7050 Mc	7 TV Pickup/STL/Inter-city Relay Stations	Yes		
7050-7125 Mc	3 TV Pickup/STL Stations	Yes—but temporarily to be used by common carriers to provide service to broadcasters.		
10500-10700 Mc	8 TV Pickup/STL/Inter-city Relay Stations	No — must accept interference from I-S-M services. Also used by Fixed and Mobile Services.		
12700-13200 Mc	20 TV Pickup/STL/Inter-city Relay Stations	Yes		

RHOMBIC/DOUBLET ANTENNAS

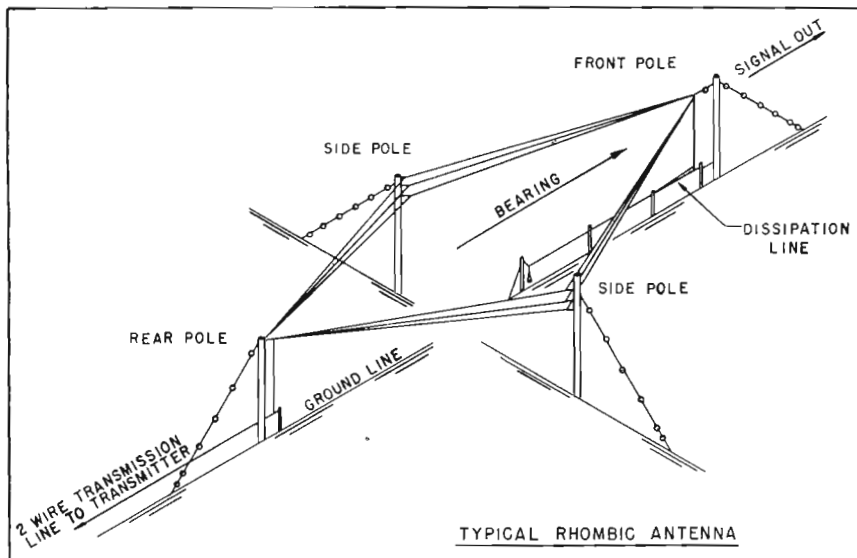

Rhombic Transmitting Antenna

Frequency range: 4-22 Mcs. Power handling capacity: 30KW. A 3-wire curtain. The Kit consists of 3-strand No. 12 Copperweld wire with maximum side lengths of 375 ft. Strain and spreader insulators with necessary hardware are included for tower or pole attachment. Downlead is supplied with transmission line kit (see RTL-300 below). See also TDL-340 below for dissipation resistor (line). Shipping weight: 500 lbs.; cubage: 8.5 cu. ft.

Model RTA-330 Rhombic Transmitting Antenna\$400.00

Transmission Line For Rhombic Transmitting Antenna

A 500 ft., 2-wire, open-wire line having a nominal characteristic impedance of 600 ohms and utilizing 3-strand No. 12 Copperweld wire—each wire spaced 12 inches apart. Includes downlead for rhombic transmitting antenna (RTA-330 above), strain insulators, line support insulators for single pole mounting, horn gap insulators with grounding wire and rods, improved entrance bowls, wooden crossarms (2) for dead-ending, guys and anchors for one dead-end and three line-turn poles; all with necessary hardware. Shipping weight: 400 lbs.; cubage: 9.1 cu. ft.

Model RTL-300 Transmission Line\$410.00

Dissipation Line For Rhombic Transmitting Antenna

Includes 1500 ft. of No. 14 AWG stainless steel wire, Type No. 302, for 2-wire downlead and 300 ft. 4-wire dissipation line, strain spreader and spacer insulators, line tension and equalization sheaves, ground wire and rod, one crossarm with pole guy and anchor for dead-ending below antenna (opposite end connects to single pole), and all necessary hardware. Shipping weight: 125 lbs.; cubage: 2.6 cu. ft.

Model TDL-340 Dissipation Line\$180.00

Doublet Transmitting Antenna

Frequency Range: 2-15 Mcs. Power handling capacity: 30KW. Antenna consists of 7-strand No. 12 Copperweld wire. Kit includes strain insulators and hardware for attaching to towers or poles. Downlead is included in transmission line kit below. Shipping weight: 90 lbs.; cubage: 2.2 cu. ft.

Model DTA-430 Doublet Antenna\$100.00

Transmission Line For Doublet Transmitting Antenna

500 ft. long, 2-wire, 600-ohm, open-wire transmission line consisting of 3-strand No. 12 Copperweld wire for downlead (delta match type) and line, dead-end crossarms, strain line support and improved entrance bowl insulators, horn gap insulators with grounding wire and rod, pole guys and anchors for dead-end poles and line turn poles, and necessary hardware. Shipping weight: 360 lbs.; cubage: 7.6 cu. ft.

Model DTL-400 Transmission Line\$370.00

PRICE NOTICE

As the basic commodity of antenna kits is metal wire, prices will fluctuate slightly upward or downward depending on market condition at time of ordering. Purchaser should take this into consideration when ordering, and Gates will not supply without notifying purchaser where increase exceeds 10% of above prices.

INDEX

<u>Description</u>	<u>Page</u>	<u>Description</u>	<u>Page</u>
A C Rectifier (for remote control)	70	C abinets (desk)	180
Adapter Kits (turntable)	136	Cabinets (disc)	143
Adapters (microphone)	166	Cabinets (loudspeaker)	174
Aircraft Homing Beacon Transmitters	224-228	Cabinets (rack)	175-180
Ampex Replacement Parts	151	Cabinets (tape)	144
Ampex Tape Recorders	145-150	Cabinets (turntable)	131, 137-138
Amplifier (communications- limiter/filter)	233	Cabinets (waist-high)	179
Amplifier (cueing)	120	Cable Hangers	167
Amplifier (disc recording)	160	Cable (microphone)	170
Amplifier (limiting)	119-120	Camera Chain	264
Amplifier (monitor)	115-116	Camera Control Equipment	255, 263
Amplifier (plug-in)	113-115	Camera Power Unit	255
Amplifier (program)	114, 116	Camera Remote Control Unit	256
Amplifier (public address)	283, 291	Camera Tripods	267
Amplifier (remote)	182-189	Camera Viewfinder	262
Amplifier (selective heterodyne type)	234	Cameras, Television	254-255, 262-264
Amplifier (tubeless tube)	189	Capacitors, Mica	285-287
Amplifiers (preamplifiers)	113	Capacitors, Oil-filled Filter	287
Amplifiers (turntable preamplifiers)	138	Cartridges (pickup)	141-142
Analyzer (capacitor-resistor)	270	Cast Aluminum Rack Housings	181
Antenna Couplers	29, 79-81	Center-post Insulator	279
Antenna Couplers (high frequency)	212	Chokes (tower)	82
Antenna Diode Unit (for remote control)	70	Clocks	170
Antenna Meter Kits (remote)	82	Coaxial Cable	275-278
Antenna Meters	29	Coils (edgewise)	295
Antennas (dummy)	291	Coils (variable)	295
Antennas (FM)	253	Collapsible Microphone Stands	167-168
Antennas (Rhombic/Doublet)	299	Communications-Limiter/Filter Amplifier	233
Antennas (television)	253	Conelrad Receivers	171
Attenuator Pads, Chart of	296	Cone Speakers	172-173
Audio Control Unit (transmitter)	63	Connectors, Amphenol	169
Audio Noise and Distortion Meter	83	Connectors, Cannon	169
Audio Oscillator	83	Console Desks	102, 127-129
Automatic (Sta-Level) Program Amplifier	117-118	Console (master preset)	130
Auxiliary Transmitter, 250 watts, Model BCA-250	49	Consoles, Speech Input	88-111
B ell & Howell TV Projector	269	Continuously Variable Turntable	137
Berlant Tape Recorders	156-157	Control Console (transmitter)	62
Biamote Remote Amplifier	184-185	Conversion Parts to increase BC-250L Transmitter to 500 watts	36
Bias Supply	115	Conversion Parts to increase BC-250L Transmitter to 1000 watts	36
Blank Panels	179-181	Conversion Parts to increase BC-500K Transmitter to 1000 watts	32
Blas? Filter (microphone)	164	Converter (frequency shift)	236
Boom Stands	167-168	Crystals, Holders and Ovens	190
Bracke? (open wire line)	279	Cueing Adapter	136
Bridging Controls	114	Cueing Amplifier	120
		Cutting Head (recording)	161

INDEX

(continued)

Description	Page	Description	Page
D azor Microphone Stands	168	G ain Measuring Set	83
Dehydrator	277	Gasoline Generating Plants	242-243
Demountable Microphone Stand	167	Gates Transcription Turntables	131-134, 138
Desks	102, 127-129	Gatesway Speech Input Console	94-97
Desk Stands (microphone)	162, 164-168	GPL Television Equipment	254-260
Directional Phasors	74-78	Gray Television Equipment	265-266
Disc Cabinets	143	Ground Rods	291
Disc Recorders	160-161	Ground Screens	291
Discs (recording blanks)	161	Ground Strap	291
Distortion Meter	83	H allicrafters Receivers	241
Double Antennas	299	Headphones	271
Dry Air Pump	277	Helix Coaxial Cable	277
Dualux Dual Channel Speech Console ...	88-93	High Frequency Transmitters see Transmitters (Communications)	
Dummy Antennas	291	Horn Gap	279
Duplex Microphone Mounting	167	Horseshoe Desk, Model CB4	128-129
Dynamote Remote Amplifier	182-183	I nductors	295
E lectric Generating Plants	242-243	Intercom Systems	284
End Plate (open wire line)	279	Isolation Coil (sampling loop)	82
Equalized Preamplifier (turntable)	138	K ay Lab Television Equipment	262-264
Equalizers (line)	121	Keyer, Frequency Shift	238
Equalizers (sound effects)	126	Keys, Telegraph	271
Equalizers (transcription pickup)	139-140	Klieglights	267-268
Equalizers (variable audio)	126	L arge Screen Television	259-260
Exciter, RF (2-32 Mc)	202	Lighting Equipment (tower)	281-282
Exhaust Fans	270	Lights (Kliegl)	267-268
F airchild Transcription Equipment	136	Lights (Warning)	170
Fans (exhaust)	270	Limiting Amplifiers	119-120
Feed-thru Bowls	279	Line Equalizers	121
Field Intensity Meter	72	Loudspeaker Cabinets	174
Film Chains	257, 264	Loudspeaker Matching Transformers	174
Filter Capacitors	287	Loudspeakers	172-174
Flashers	281-282	Loudspeaker Wall Baffles	174
FM Antennas	253	Low Frequency Transmitters see Transmitters (Communications)	
FM Monitor Amplifier (for remote control)	71	M agnecord Replacement Parts	155
FM Monitor Unit (for remote control)	71	Magnecord Tape Recorders	152-154, 294
FM Output Indicator (for remote control)	70	Master Oscillators	239
FM Receivers	241-244	Master Preset Console	130
FM Transmitters see Transmitters (Broadcast)		Matching Transformers (loudspeaker)	174
Frequency, related to tower height	297	Meters	291
Frequency and Shift Monitor	237	Meter Shorting Switches	291
Frequency Monitors	58-59	Mica Capacitors	285-287
Frequency Shift Converter	236		
Frequency Shift Keyer	238		
Frequency Standard	190		
Frequencies used in broadcast service	298		

INDEX

(continued)

<u>Description</u>	<u>Page</u>	<u>Description</u>	<u>Page</u>
Microphone Banquet Stands	167	Phase Sampling Loops	80
Microphone Boom Stands	167-168	Phones	271
Microphone Cable	170	Photo-cell Units (tower lights)	282
Microphone Call Letter Plates	170	Pickup-Amplifier Kit	138
Microphone Connectors	169	Pickup Cartridges (turntable)	141-142
Microphone Desk Stands	162, 164-168	Pickups (transcription)	138-142
Microphone Exchange Prices (Altec)	162	Plate Current Extension Unit (for remote control)	70
Microphone Floor Stands	167-168	Plate Voltage Extension Unit (for remote control)	70
Microphones	162-166, 215-216	Pliers	278
Microphone Sky Hook	167	Plug-in Amplifiers (power supplies)	112-115
Microphone Stands (Dazor, flexible)	168	Plug-in Base and Receptacle	112
Midgetape Pocket Recorder	157	Police Transmitters (special purpose)	221-223
Modulation Monitors	60, 229	Portable Remote Amplifiers	182-189
Monitor Extension Meters (for remote control)	71	Power Reduction Kit, 1000/500 watts (for BC-1J transmitter)	29
Monitor (frequency and shift)	237	Power Supplies	113, 115
Monitoring Amplifiers	115-116	Power Supply (direct current)	171
Monitor (master)	256, 263	Preamplifier (General Electric)	140
Motor Operated Rheostats (for remote control)	70	Preamplifier (Pickering)	140
Motor (tuning, for remote control)	70	Preamplifiers	113
Multiplexer System (television)	258, 265	Presidential Amplifier	185
Muting/Warning Light Unit (Yard accessory)	102	Presto Transcription Turntables	135-136
N ational Receivers	240	Proof of Performance Equipment	83
Noise and Distortion Meter	83	Proof of Performance (summary of)	84
O hm-meters	271	Public Address Systems	283, 291
Open Wire Transmission Line	279-280	R ack Cabinets	175-180
Oscillator-Amplifier (2-32 Mc)	202	Rack Housings	181
Oscillators (master)	239	Receiver (television rebroadcast)	269
Oscilloscopes	270	Receivers (Conelrad)	171
Output Switching Unit	102	Receivers (FM rebroadcast)	244
Overload Relay Assembly (for remote control)	70	Receivers (Hallicrafters)	241
P aging Transmitter Control Console	232	Receivers (Hi-Fi)	291
Paging Transmitters	230-232	Receivers (National)	240
Panel and Shelf Assembly	112	Receiving Type Tubes	288-289
Panels (blank)	179-181	Record Changers	291
Panel, Switch and Fuse	121	Recorders (disc)	160-161
Patch Cords	122	Recording Cutting Heads	161
Patch Panel Cabinet (Yard accessory)	102	Recording Discs	161
Patch Panels	122	Recording Mechanism (overhead)	161
Patch Panels (video)	266	Recording Stylus	161
Pentron Tape Recorders	158	Recording Tape	159, 270
Phase Monitors	72	Rectifier Pickup Coil	83
Phasers (directional antenna)	74-78	Regulated Power Supply	115
		Regulators (voltage)	272-274
		Rek-O-Kut Transcription Turntables	137
		Relay Assembly for Controlling Motors (remote control)	70
		Remote Amplifier Equipment	182-189

INDEX

(continued)

<u>Description</u>	<u>Page</u>	<u>Description</u>	<u>Page</u>
Remote Antenna Meters	82	T apak Springwound Recorder	157
Remote Control Systems (unattended operation)	64-71	Tape Cabinets	144
Remote Control Unit (camera)	256, 263	Tape Erasers	161
Remote Monitors (television)	264	Tape Recorder Replacement Parts, Ampex	151
RF Amplifier for Monitors (remote control) ..	71	Tape Recorder Replacement Parts, Magnecord ..	155
Rhombic Antennas	299	Tape Recorders, Ampex	145-150
		Tape Recorders, Bell	171
		Tape Recorders, Berlant	156-157
S ampling Loop Isolation Coil	82	Tape Recorders, Magnecord	152-154, 294
Sampling Loops (phase)	80	Tape Recorders, Midgetape Pocket	157
Scotch Brand Recording Tape	159, 270	Tape Recorders, Pentron	158
Screens (ground screens)	291	Tape Recorders (springwound)	157
Seeburg Automatic Changer	291	Tape (Scotch brand)	159, 270
Selective Amplifier (heterodyne filter)	234	Tape Splicers	161
Shielded Audio Wire	271	Television Equipment:	
Shock Mounts (microphone)	164	100 watt television transmitter	246-248
Short Wave Receivers	240-241	500 watt television transmitter	249-252
Short Wave Transmitters see Transmitters (Communications)		Antennas	253
Single Channel Remote Amplifier	185-187	Camera Control Unit	255
Slide Projectors	266	Camera Power Unit	255
Soldering Irons	278	Cameras	254-255, 262-264
Solid Dielectric Coaxial Cable	278	Camera Tripods	267
Speech Input Equipment:		Camera Turret	266
CB4 Desk Combinations, less turntables ..	129	Gray Telejector	265
CB4 Desk Combinations, with turntables ..	129	Gray Telop	266
CB4 Desk, with turntables and Gatesway console	129	Klieglights	267-268
Dualux Dual Channel Console	88-93	Large Screen TV Projection System	259
Gatesway Speech Input Console	94-97	Master Monitors	256, 263
Master Preset Console	130	Multiplexers	258, 265
Sound Effects Equalizers	126	Remote Monitors	264
Sound Effects Equipment	123-125	Synchronous Generator	255, 264
Sta-Level Automatic Program Amplifier	117-118	Telecast Projectors	258, 269
Studioette Speech Input Console	103-105	Telejector, Gray	265
Switch and Fuse Panel	121	Telop, Gray	266
Television Audio Control Console	106-111	Tripods (camera)	267
Yard Desk	102	TV Rebroadcast Receiver	269
Yard (Muting/Warning Light Unit)	102	Video Patch Panels	266
Yard (output switching unit)	102	Video Switchers	256, 263
Yard (patch panel cabinet)	102	Vidicon Film Chain	257, 264
Yard Speech Input Console	98-101	Terminal Boards	121
Stylus Force Gauge	138	Test Equipment	270
Strap (ground strap)	291	Tools	278
Studio Warning Lights	170	Totalizing Recorder	235
Suspension Mounting (microphone)	164	Tower height, related to Frequency	297
Switcher (video)	256, 263	Tower Lighting Equipment	281-282
Switches (meter shorting)	291	Tower Light Isolation Chokes	82
Synchronous Generators	255, 264	Tower Light Parts, Hughey & Phillips	282
		Transcription Equalizers	139-140
		Transcription Pickups	138-142
		Transcription Playback Equipment	171

INDEX

(continued)

<u>Description</u>	<u>Page</u>	<u>Description</u>	<u>Page</u>
Transcription Turntables	131-137	Transmitters (Communications):	
Transformers	292-294	HF-20B, 20KW short wave transmitter	6-12
Transformers (loudspeaker matching)	174	HF-20BX, 20KW short wave telephone transmitter	6-12
Transistor Remote Amplifiers	186-188	HF-20BX, 20KW short wave telephone and telegraph transmitter	6-12
Transmission Line (open wire)	279-280	HF-20TX, 20KW short wave telegraph transmitter	6-12
Transmitter Accessory Unit	61	FMR-250, 250 watt FM transmitter (88-200 Mc)	54-55
Transmitter Audio Control Unit	63	5000/10,000 watt short wave transmitter	193-201
Transmitter Control Console	62	65 watt transmitter (2-32 Mc)	204-205
Transmitters (Broadcast):		1000 watt transmitter (2-32 Mc)	206-212
BC-20B, 20KW medium wave broadcast transmitter	12	250 watt transmitter (2-26 Mc)	213-215
HF-20B, 20KW short wave broadcast transmitter	12	250 watt unit system (multi-band)	216-220
HF-20BX, 20KW short wave broadcast and telegraph transmitter	12	1000 watt high speed telegraph transmitter	221-223
BC-5E, 5000 watt broadcast transmitter (Deluxe)	14-22	Low frequency homing beacon transmitter	224-228
BC-5E, 5000 watt broadcast transmitter (Custom)	14-22	Paging transmitter (35-45 Mc)	230-232
BC-10E, 10,000 watt broadcast transmitter (Deluxe)	14-22	Tubeless Tube	189
BC-10E, 10,000 watt broadcast transmitter (Custom)	14-22	Tube Sockets (transmitting)	291
BC-1J, 1000 watt "Hi-Walter" broadcast transmitter	24-29	Tubes (receiving)	288-289
Power reduction kit for 1000/500 watts	29	Tubes (transmitting)	289-290
RF ammeters for BC-1J transmitter	29	Tube Tester	270
BC-500K, 500 watt broadcast transmitter	30-32	Turntable Cabinets	131, 137-138
Conversion parts to increase BC-500K to 1000 watts	32	Turntable Cartridges	141-142
BC-250L, 250 watt broadcast transmitter	33-36	Turntable Preamplifiers	138, 140
Conversion parts to increase BC-250L transmitter to 500 watts	36		
Conversion parts to increase BC-250L transmitter to 1000 watts	36	U nattended Operation (remote control)	64-71
BC-1F, 1000 watt broadcast transmitter	37-41		
GY-1000 complete packaged 1000 watt radio station	41	V acuum Tube Voltmeter	271
BC-250GY, 250 watt broadcast transmitter	43-46	Vidicon Film Chains	257, 264
GY-48A complete 250 watt packaged radio station	47	Voltage Regulators	272-274
BCA-250, 250 watt auxiliary broadcast transmitter	48-49	Volt-Ohm-Meter	271
BF-3E, 3KW FM broadcast transmitter	50-53	Volume Indicator Panel	121
FMR-250, 250 watt FM broadcast transmitter	54-55		
BF-E-10A, 10 watt FM broadcast transmitter	56-57	W arning Lights (studio)	170
BF-E-50A, 50 watt FM broadcast transmitter	56-57	Wire (ground wire)	291
		Wire (hard drawn for open wire line)	279
		Wire (shielded audio)	271
		Wireless Microphone	166
		Y ard Desk	102
		Yard Speech Input Console	98-101

PRICE LIST

For items not priced in the catalog, reference is made to this pink supplemental price list. All prices are F. O. B. Quincy, Illinois, domestic packed. Prices are subject to change without notice. For overseas packing add 2½ % to all items selling for over \$2000.00 and 4 % for each item selling under \$2000.00.

Page	Item	Price
12	BC-20B 20KW Transmitter with one set tubes, crystal and oven	\$33,500.00
	HF-20B 20KW Transmitter with one set tubes, less crystals	34,658.00
	HF-20BX 20KW Transmitter with one set tubes, less crystals	34,998.00
	HF-20TX 20KW Transmitter with one set tubes, less crystals	22,900.00
	JK03-H17 crystal and holder for high frequency models	27.45
	JK57M crystal and oven for medium frequency models	50.00
	TK-139 spare 100 % tube complement for BC-20B, HF-20B, HF-20BX	2,011.00
	TK-140 spare 100 % tube complement for HF-20TX	1,046.70
22	M-5135, Model BC-5E Transmitter (deluxe) with one set tubes, crystal and oven	15,750.00
	M-5135A, Model BC-5E Transmitter (custom) with one set tubes, crystal and oven	16,750.00
	M-5284, Model BC-10E Transmitter (deluxe) with one set tubes, crystal and oven	17,500.00
	M-5284A, Model BC-10E Transmitter (custom) with one set tubes, crystal and oven ..	19,200.00
	JK57M spare crystal and oven	50.00
	TK-204 spare 100 % tube complement for BC-5E	497.68
	M-3825 spare 100 % tube complement for BC-10E	1,082.30
29	BC-1J 1KW Transmitter with tubes, crystal and oven	4,395.00
	M-3768A Power Reduction Kit for 1000/500 watts	50.00
	M-5177 RF Ammeter in case, 0-6 amperes	35.00
	M-5177A RF Ammeter in case, 0-3 amperes	35.00
	M-5178 Antenna coupling unit, series fed	125.00
	M-5179 Antenna coupling unit, shunt fed	125.00
	TK-206 spare 100 % tube complement for BC-1J	251.16
	TK-208 FCC required spare tube complement for BC-1J	126.83
	JK57M extra crystal and oven	50.00
32	BC-500K Transmitter with one set tubes, crystal and oven	3,895.00
	TK-214 spare 100 % tube complement for BC-500K	201.66
	TK-208 FCC required spare tube complement for BC-500K	126.83
	JK57M extra crystal and oven	50.00
	M-5218 Conversion parts to increase power to 1000 watts	549.50
36	BC-250L Transmitter with tubes, crystal and oven for 540-1600 Kc coverage	2,995.00
	TK-207 spare 100 % tube complement for BC-250L	118.16
	TK-218 FCC required spare tube complement for BC-250L	60.33
	JK57M extra crystal and oven	50.00
	M-5216 Conversion parts to increase to 500 watts	1,048.00
	M-5217 Conversion parts to increase to 1000 watts	1,598.00
41	BC-1F Transmitter with one set of tubes, one crystal and oven, for 1000 watts output, M-3250	5,950.00
	BC-1F Transmitter with one set of tubes, one crystal and oven, for 1000/500 watts output, M-3410	6,000.00
	GY-1000 complete radio station with one set of tubes, crystal and oven, includes joiner panel and 12" monitoring loudspeaker	7,635.00
	JK57M extra crystal and oven	50.00
	M-3379 100 % spare tube complement	305.25
46	BC-250GY complete 250 watt transmitter with one set of tubes, crystal and oven....	2,443.00
	M-3074 100 % spare tube complement for BC-250GY	107.90
	TK-201 FCC spare tube complement for BC-250GY	65.66
	JK57M extra crystal and oven for BC-250GY	50.00
47	GY-48A complete 250 watt radio station with one set of tubes, crystal and oven	4,068.00
49	BCA-250 Auxiliary Transmitter with tubes, less crystal and oven	1,295.00
	BCA-250CR Auxiliary Transmitter with Conelrad provision, with tubes, less crystal and oven	1,355.00
	TK-157 complete 100 % set spare tubes	38.00
	JK57M extra crystal and oven	50.00

PRICE LIST

(continued)

Page	Item	Price
53	BF-3E 3KW FM Transmitter with one set tubes, crystal and oven	\$ 9,600.00
	TK-224 spare 100% tube complement for BF-3E	456.45
	JK07E spare crystal and oven	69.45
55	FMR-250B Transmitter for 88-108 Mc broadcast model with tubes, crystal and oven	2,695.00
	FMR-250 Transmitter for 150-200 Mc full fidelity model ± 75 Kc swing, with tubes, crystal and oven	2,695.00
	FMR-250E Transmitter for any frequency between 88 and 228 Mc with ± 25 Kc swing, with tubes, crystal and oven	2,795.00
	TK-169 100% set of tubes for FMR-250B	135.30
	M-4054 100% set of tubes for FMR-250 and FMR-250E	155.96
	JK07E spare crystal and oven	69.45
57	BF-E-10A Transmitter with tubes, crystal and oven, M-4844	1,295.00
	BF-E-50A Transmitter with tubes, crystal and oven, M-5219	1,495.00
	TK-187 100% spare tube complement for BF-E-10A	49.95
	TK-197 100% spare tube complement for BF-E-50A	61.48
	JK07E spare crystal and oven	69.45
72	Price correction—Model 120D field intensity meter, shown as \$790.00—reduced to	750.00
74-78	Directional Phasors	Prices on application
201	5/10KW Transmitters exactly as described bottom of Page 201:	
	HF-5B Transmitter, 5KW	21,900.00
	HF-10B Transmitter, 10 KW	24,059.00
	HF-5BX Transmitter, 5KW	22,300.00
	HF-10BX Transmitter, 10KW	24,459.00
	HF-5C Transmitter, 5KW	19,250.00
	HF-10C Transmitter, 10KW	21,500.00
	HF-5CX Transmitter, 5KW	19,650.00
	HF-10CX Transmitter, 10KW	21,900.00
	HF-5TX Transmitter (telegraph), 5KW	15,485.00
	HF-10TX Telegraph Transmitter, 10KW	15,985.00
	JK03H17 crystal and oven	27.45
	TK-252, 100% tube complement	1,003.32
	TK-253, 100% tube complement	1,079.36
	TK-254, 100% tube complement	571.66
	TK-255, 100% tube complement	571.66
	TK-256 tube set for keyer	5.00
	NOTE 1: Where any of above transmitters for operation to 32 Mc, add \$950.00.	
	NOTE 2: Where any transmitter desired for single frequency operation between 2-5.4 Mc, deduct \$468.00.	
	NOTE 3: Where any transmitter desired for single frequency operation between 5-12 Mc, deduct \$885.00.	
	NOTE 4: Where any transmitter desired for single frequency operation between 11.7-22 Mc, deduct \$902.00.	
202	M-5239 Exciter amplifier with tubes, less crystals	325.00
	H7 crystal and holder	14.95
	H17 crystal and holder	14.95
	JK02 oven only	12.50
	TK-250, 100% spare tube complement	16.03
203	20KW Transmitters	see Page 12 prices
205	M-5354, 65 watt transmitter with one set tubes, less crystals	745.00
	TK-251, 100% tube complement	38.97
	H7 crystal and holder	14.95
	H17 crystal and holder	14.95
	JK02 temperature controlled oven	12.50
212	HF-1M high frequency transmitter with one set of tubes, less crystals	5,950.00
	TK-249 spare 100% tube complement for above	284.75
	H7 crystal and holder for 0.02% accuracy	14.95
	H17 crystal and holder for 0.005% accuracy (mounts in JK42 oven	14.95
	JK02 temperature controlled oven (hold one or two H17)	12.50
	M-5263 limiter/filter audio amplifier	210.00

PRICE LIST

(continued)

Page	Item	Price
215	CMG-1 complete transmitter with tubes, less crystals	\$ 1,650.00
	H17 crystals in holder (less oven)	14.95
	TK-136 spare 100% tube complement	73.35
	M-4576 microphone assembly complete	36.00
	Filters for added second harmonics attenuation: LPF-52 for 50 ohms	49.50
	LPF-72 for 72 ohms	49.50
	LPF-250 for 250 ohms	49.50
217	M-3449Y two channel telephone and telegraph transmitter with one set of tubes, less crystals	1,795.00
	TK-222 spare 100% tube complement	51.26
	Plug-in coil sets: M-3641 for 2-3 Mc	16.00
	M-3642 for 3-4.2 Mc	16.00
	M-3643 for 4-7.2 Mc	16.00
	M-3644 for 7-13 Mc	16.00
	M-3645 for 12-22 Mc	16.00
	H7 crystal and holder for 0.02% accuracy	14.95
	H17 crystal and holder for use in JK02 oven, 0.005% accuracy	14.95
	JK02 temperature controlled oven only for mounting H17 crystals	12.50
	M-4237 complete push-to-talk microphone assembly	38.00
218	M-3491Y single channel telephone and telegraph transmitter with one set of tubes, less crystals	1,550.00
	TK-237 spare 100% tube complement	39.15
	Plug-in coil sets: M-3641 for 2-3 Mc	16.00
	M-3642 for 3-4.2 Mc	16.00
	M-3643 for 4-7.2 Mc	16.00
	M-3644 for 7-13 Mc	16.00
	M-3645 for 12-22 Mc	16.00
	H7 crystal and holder for 0.02% accuracy	14.95
	H17 crystal and holder for use in JK02 oven, 0.005% accuracy	14.95
	JK02 temperature controlled oven only for mounting H17 crystals	12.50
	M-4237 complete push-to-talk microphone assembly	38.00
219	M-3680Y single channel telephone and telegraph transmitter with tubes, less crystal	1,381.00
	TK-237 spare 100% tube complement	39.15
	Plug-in coil sets: M-3641 for 2-3 Mc	16.00
	M-3642 for 3-4.2 Mc	16.00
	M-3643 for 4-7.2 Mc	16.00
	M-3644 for 7-13 Mc	16.00
	M-3645 for 12-22 Mc	16.00
	H7 crystal and holder for 0.02% accuracy	14.95
	H17 crystal and holder for use in JK02 oven, 0.005% accuracy	14.95
	JK02 temperature controlled oven only for mounting H17 crystals	12.50
	M-4239 single channel coupler for mounting adjacent to transmission line if antenna remote from transmitter	80.00
M-4237 complete push-to-talk microphone assembly	38.00	
220	M-3629Y single channel telegraph transmitter with tubes, less crystals	1,058.00
	TK-238 spare 100% tube complement	21.30
	Plug-in coil sets: M-3641 for 2-3 Mc	16.00
	M-3642 for 3-4.2 Mc	16.00
	M-3643 for 4-7.2 Mc	16.00
	M-3644 for 7-13 Mc	16.00
	M-3645 for 12-22 Mc	16.00
	H7 crystal and holder for 0.02% accuracy	14.95
	H17 crystal and holder for use in JK02 oven, 0.005% accuracy	14.95
	JK02 temperature controlled oven only for mounting H17 crystals	12.50
	M-4239 single channel antenna coupler	80.00
223	CMP-1 complete transmitter for operation on 2804, 2808 and 2812 Kc, with tubes, less crystals	3,785.00
	CMP-1A complete transmitter for operation on 5135, 5140 and 5195 Kc, with tubes, less crystals	3,785.00
	CMP-1B complete transmitter for operation on 7480, 7805 and 7935 Kc, with tubes, less crystals	3,785.00

PRICE LIST

(continued)

<u>Page</u>	<u>Item</u>	<u>Price</u>
223	CMP-1D complete transmitter for operation on any closely associated frequencies not stated above to 22 Mc, with tubes, less crystals	\$ 3,975.00
	CON-2 remote control panel, rack mount	116.50
	TK-138 spare 100% tube complement for above transmitters	166.90
228	M-3975 (new number M-4031) beacon transmitter	5,995.00
	M-4116 antenna coupler	325.00
	M-4033 remote control/audio amplifier, less microphone and desk assembly	450.00
	M-4124 microphone and desk assembly	38.00
	JK02H17 crystal and holder	27.45
	NOTE: Prices shown are in single quantities. To joint Army-Navy specifications. Write for quantity prices and/or non JAN design.	
232	M-5245 high frequency transmitter	2,885.00
	TK-232, 100% tube complement	105.17
	M-5272 control console	325.00
	TK-257, 100% tube complement	5.76
	JK02H17 crystal and oven	27.45
248	BT-100A, 100 watt TV transmitter with one set of tubes, two crystals and ovens, M-5113	5,250.00
	TK-212, 100% spare tube complement	235.25
	JK09 spare crystal and oven for visual section	32.20
	JK07E spare crystal and oven for aural section	69.45
252	BT-1A-L, 500 watt TV transmitter, Channels 2-6, complete with one set of tubes, two crystals and ovens	16,000.00
	BT-1A-H, 500 watt TV transmitter, Channels 7-13, complete with one set of tubes, two crystals and ovens	16,750.00
	JK09 crystal and oven	32.20
	JK07E crystal and oven	69.45
	TK-160, 100% tube complement for BT-1A-L transmitter	443.00
	TK-258, 100% tube complement for BT-1A-H transmitter	414.68
254	PA600 basic image orthicon camera chain	10,000.00
	Consisting of:	
	PA601 camera (lenses optional accessory listed below)	
	PA602 camera control unit	
	PA603 camera control unit power supply	
	PA801 interconnecting cables, except camera cable	
	PA802 tube complement, except image orthicon tube	
	PA803 two sets intercom headphones	
	Other pertinent accessories to PA600 camera chain, not specifically listed in catalog, as follows:	
	PA6001 complete spare tube complement for PA600 including image orthicon tube	1,550.00
	PA6002 complete spare tube complement for PA600 camera chain, less image orthicon tube	350.00
	5820 image orthicon tube only	1,200.00
	PA804 camera cable with connectors, length 50 ft.	225.00
	PA804A camera cable with connectors, length 100 ft.	325.00
	PA804B camera cable with connectors, length 200 ft.	495.00
	PA859 lens, 39 mm, f/2.0	250.00
	PA850 lens, 2" f/1.9	225.00
	PA860 lens, 2 1/2" f/1.9	235.00
	PA850A lens, 3" f/1.9	200.00
	PA851 lens, 4" f/1.9	275.00
	PA851A lens, 4" f/3.5	185.00
	PA858A lens, 6" f/2.9	300.00
	PA853 lens, 8" f/2.9	325.00
	PA853A lens, 9" f/5.6	275.00
	PA854 lens, 12" f/4.5	350.00
	PA855 lens, 17" f/5.6	375.00
	PA856 lens, 20" f/5.6	400.00
	PA857 lens, 24" f/6.5	425.00
	PA861 Vari-Focal lens (3"—30" in two 5/1 ranges), specify camera adapter required, includes carrying case	6,900.00

PRICE LIST

(continued)

Page	Item	Price	
255	PA602 camera control unit	supplied with PA600	
	PA603 camera power unit	supplied with PA600	
	PA604 synchronous generator, portable type, including self-contained power supply, with tubes	3,500.00	
	PA604C synchronous generator for rack mounting, requires PA823 power supply listed below, with tubes	1,800.00	
	PA823 rack mount power supply for PA604C synchronous generator above, with tubes	575.00	
	PA6041 spare tube complement for PA604 synchronous generator	206.00	
	PA611 sync pulse distribution box	60.00	
	5087-54 AC cable for synchronous generator	10.00	
	5087-66 video termination plug assembly for sync generator	1.50	
	5121-286 sync termination plug assembly for sync generator	7.50	
	256	PA606 master monitor, portable, with tubes	2,500.00
PA610 camera remote control unit		100.00	
5087-78 cable for remote control unit		65c per foot	
PA605 video switcher, portable or studio model, with tubes		2,500.00	
PA6052 spare tube complement for PA605		48.36	
257	PA505 vidicon film chain, monochrome	5,160.00	
	Including:		
	130-1-6326 vidicon		
	220-4-1 camera lens, 25 mm		
	5208-1 power supply		
	5272-1 camera		
	5272-2 video chassis		
	5272-3 control panel		
	5272-4 sweep chassis		
	5272-5 bias supply		
	5272-21 power interconnecting cable		
	5272-403 video-sweep jumper		
	5146-23 manual		
	5272-22 control cable (specify length)		
	258	PA100C telecast projector, 16 mm (color or monochrome)	3,950.00
		Consisting of:	
		5080-116 magazine assembly	
5304-3 magazine assembly			
5080-119 base-pedestal			
5304-2 leveling assembly-pedestal			
5086-1 preamplifier			
5087-18 cable-audio output			
5088-1 RF power supply			
5146-24 manual			
5081-86 installation kit			
NOTE: Specify projection lamp and lens desired as listed below.			
5119-7 projection lamp, 750W		10.36	
5119-8 projection lamp, 1000W		12.62	
5119-29 projection lens, 3.5" f/1.6	150.00		
5119-233 projection lens, 4.0" f/1.6	175.00		
PA525 multiplexer system with base	750.00		
PA13 power supply, 24V, 5A, DC, for PA100C	235.00		
260	PB611B television projection system	2,975.00	
262	1984B vidicon camera with camera control unit, listed Page 263, less vidicon tube and lens, includes 25 ft. AC-2 camera control cable	2,200.00	
	6326 vidicon tube only	515.00	
	1984BF complete unit including 1984B, ASC-1 viewfinder as illustrated and camera control unit, includes case, less vidicon tube and lens	3,350.00	
	ASC-1 viewfinder only, less camera, with 4" lens, turret adapter	1,000.00	
	AL-1 lens, 1/2" f/1.5	119.25	
	AL-2 lens, 1" f/1.5	92.75	

PRICE LIST

(continued)

Page	Item	Price
262	AL-4 lens, 2" f/1.5	\$ 130.00
	AL-6 lens, 3" f/2.5	87.50
	AL-8 lens, 6" f/4.5	98.50
	AL-9A lens, 1", 3" f/2.8 Zoomar	600.00
263	ASF2 four-channel video switcher-fader	1,000.00
	ARM13A master monitor	900.00
	ACH4 housing for mounting ARM13A monitor	345.00
264	System 2A single camera chain complete	4,485.75
	System 2B camera chain complete, including line monitor and line amplifier	5,980.75
	System 2C camera chain complete, including line monitor, line amplifier and sync generator	7,930.75
	ARM-1 monitor, 10"	350.00
	ARM-2 monitor, 17"	425.00
	ARM-3 monitor, 21"	550.00
	APG4 synchronous generator, including field case	2,100.00
	APG4R synchronous generator for rack mounting	1,950.00
	GR7 film and slide chain	8,180.00
267	Lamps only for Kliegligh's:	
	100 watt Bayonet base, Cat. 100/G16 1/2 /29DC	1.50
	150 watt Bayonet base, Cat. 150/G16 1/2 /DC	2.95
	500 watt Med. prefocus, Cat. 500/T20/64	5.50
	750 watt Med. prefocus, Cat. 750/T20P/SP	6.60
	1000 watt Med. prefocus, Cat. 1M/G40/PSP	7.10
	1500 watt Med. prefocus, Cat. 1500/G40/15	12.10
	2000 watt Med. prefocus, Cat. 2M/G48/4	14.35
	2000 watt Mogul, BP base, Cat. 2M/G48, 85P	14.00

In the preparation and pricing of an extensive catalog such as this, it becomes obvious, because of the human element, errors in printing, and other unintentional mistakes for any cause, that information provided in the pages of this catalog, though having been proof read many times, may in certain instances completely beyond our control, be subject to error. — Prices shown are the latest prices at time of publication. As prices change almost on a daily basis because of rapid fluctuations in raw material costs, all prices are subject to change either upward or downward without notice. It is particularly called to the attention of our customers that items having as their basic commodity, copper, such as wire, coaxial cable, etc., are subject to rapid fluctuation because of the current day to day change in the copper market and prices shown will vary either upward or downward as the copper market fluctuates. Every effort is made to be sure that the specifications stated for any item in this catalog are correct and accurate. Gates reserves the right to alter any product either for improvement or manufacturing economies wherein the nature of the product is not substantially altered, and without notice to the customer. Additional detailed sales brochures are available on many of the items listed within this catalog and will be supplied on request, without charge. Requests for instruction books on any product will be honored, where possible, but in every instance a modest charge for instruction books will be made, depending upon the nature of the product. Instruction books are only supplied on a replacement basis and are not available as sales literature. Customer requesting instruction books should give the serial number of the equipment which replacement instruction book is required.

GATES RADIO COMPANY

Manufacturing Engineers Since 1922

Quincy, Illinois, U. S. A.

Telephone: Baldwin 2-8202

Cable Address: GARCO
Quincy, Illinois

TWX Number (Quincy, Illinois): QCY ILL 90

6A

FOR NIGHT, SATURDAY, SUNDAY AND HOLIDAY EMERGENCY SERVICE,
PLACE ALL CALLS TO TELEPHONE NUMBER BALDWIN 2-5088.

www.americanradiohistory.com