

**TECHNICAL
MANUAL**

CIRCULARLY POLARIZED
CLASS A, FM ANTENNA



WARRANTY

Seller warrants new equipment manufactured by Gates Radio Company against defects in material or workmanship at the time for delivery thereof, that develop under normal use within a period of one year (6 months on moving parts) from the date of shipment, of which Purchaser gives Seller prompt written notice. Other manufacturers' equipment, if any, including electron tubes, and towers shall carry only such manufacturers' standard warranty.

Seller's sole responsibility for any breach of the foregoing provision of this contract, with respect to any equipment or parts not conforming to the warranty or the description herein contained, is at its option, (a) to repair or replace such equipment or parts upon the return thereof f.o.b. Seller's factory within the period aforesaid, or (b) to accept the return thereof f.o.b. Purchaser's point of installation, whereupon Seller shall either (1) issue a credit to Purchaser's account hereunder in an amount equal to an equitable portion of the total contract price, without interest, or (2) if the total contract price has been paid, refund to Purchaser an equitable portion thereof, without interest.

If the Equipment is described as used, it is sold as is and where is. If the contract covers equipment not owned by Seller at this date it is sold subject to Seller's acquisition of possession and title.

Seller assumes no responsibility for design characteristics of special equipment manufactured to specifications supplied by or on behalf of Purchaser.

Seller shall not be liable for any expense whether for repairs, replacements, material, service or otherwise, incurred by Purchaser or modifications made by Purchaser to the Equipment without prior written consent of Seller.

EXCEPT AS SET FORTH HEREIN, AND EXCEPT AS TO TITLE, THERE ARE NO WARRANTIES, OR ANY AFFIRMATIONS OF FACT OR PROMISES BY SELLER, WITH REFERENCE TO THE EQUIPMENT, OR TO MERCHANTABILITY, INFRINGEMENT, OR OTHERWISE, WHICH EXTEND BEYOND THE DESCRIPTION OF THE EQUIPMENT ON THE FACE HEREOF.

RETURNS AND EXCHANGES

Do not return any merchandise without our written approval and Return Authorization. We will provide special shipping instructions and a code number that will assure proper handling and prompt issuance of credit. Please furnish complete details as to circumstances and reasons when requesting return of merchandise. Custom built equipment or merchandise specially ordered for you is not returnable. Where return is at the request of, or for the convenience of the customer, a restocking fee of 15% will be charged. All returned merchandise must be sent freight prepaid and properly insured by the customer. When writing to Gates Radio Company about your order, it will be helpful if you specify the Gates Factory Order Number or Invoice Number.

WARRANTY ADJUSTMENTS

In the event of equipment failure during the warranty period, replacement or repair parts may be provided in accordance with the provisions of the Gates Warranty. In most cases you will be required to return the defective merchandise or part to Gates f.o.b. Quincy, Illinois for replacement or repair. Cost of repair parts or replacement merchandise will be billed to your account at the time of shipment and compensating credit will be issued to offset the charge when the defective items are returned.

MODIFICATIONS

Gates reserves the right to modify the design and specifications of the equipment shown in this catalog without notice or to withdraw any item from sale provided, however, that any modifications shall not adversely affect the performance of the equipment so modified.

800 0831 001



CIRCULARLY POLARIZED CLASS A
FM ANTENNA

PROPRIETARY DATA

This document contains proprietary data of Harris-Intertype Corporation.

No disclosure, reproduction, or use of any part thereof may be made except by written permission.

FOREWORD

This Instruction Book provides the necessary information for application, installation, operation, adjustment, and maintenance of the Model FMC-(No. of bays) A, Class A, Circularly Polarized FM Antenna.

This antenna provides the broadcaster with all the electrical advantages of higher power installations, while maintaining a compact, low silhouette configuration for minimum windloading.

GENERAL

Before the antenna and associated transmission line are placed in service, tests should be made to insure that the overall system is operating properly. This is important in order to detect any errors which may have been made during installation. A VSWR of less than 1.5 to 1 at the operating frequency is to be expected. If a higher VSWR is observed, there may be a mechanical defect in the transmission line or antenna.

888 1056 001

SECTION 1 - INSTALLATION

- 1.1 Check all components carefully on receipt to ascertain if any damage has been sustained during shipment. If any parts are damaged, notify the carrier promptly. In addition, the Gates Customer Service Department should be notified of any damage or shortages so that replacement parts may be shipped promptly to avoid delay in the installation.
- NOTE:** *Protect the transmission line and antenna feed blocks from dirt and moisture prior to installation. Exercise care in erection to avoid damaging the transmission line and antenna elements.*
- 1.2 The sections of rigid coaxial line supplied with the antenna are designed to space the antenna elements approximately one wavelength apart. During assembly, make certain that "O" rings (round neoprene gaskets) are installed between sections of transmission line and also between the transmission line and the antenna feed blocks.
- 1.3 One six foot transformer section is supplied to be attached to the bottom antenna line block, as marked. This coaxial line section has a standard 1 - 5/8" EIA female flange to accommodate standard EIA 50 ohm feed line. (The mating 1 - 5/8" heliax 50 ohm EIA flange is the Andrew Type 87R used with the Andrew Type 34660 inner connector).
- 1.4 The mounting brackets normally supplied allow for the use of two brackets for each section of 1 - 5/8" coaxial interconnecting line between antenna bays. The lower bracket for each bay should be mounted approximately 12 inches below each line block. The upper bracket for each bay should be mounted 12 inches above each line block.
- 1.5 Insure that all antenna elements are attached in the same manner. The red band on the vertical section of each antenna bay must face downward to assure proper phase relationship between the stacked bays.
- 1.6 In multiple bay installations, each antenna section has a number stamped on the flange which attaches the antenna element to the line block. The element with the smaller number should always be on top. When the antenna has been completely assembled, the numbers on the flanges will read consecutively from the top to the bottom of the antenna.
- 1.7 Numbers have been stamped into the flanges on each section of the interconnecting coaxial line. As the antenna is assembled, the numbers on the line flanges should match with the numbers stamped on each element flange; i.e., the No. 1 line flange should be bolted to the line block adjacent to the No. 1 on the antenna element flange, etc. All feed straps of all elements will be on the same side of the antenna if this procedure is followed.
- 1.8 Care should be exercised in assembling the inner conductor of the coaxial line to the inner conductor connector, or bullet. The inner conductor should be perfectly centered on the bullet as it is being installed in order to prevent bullet damage. The bullet should fit firmly in the inner conductor to assure a minimum R.F. resistance connection. Many antenna troubles have been traced to improper installation of bullets between the inner conductors of the transmission line.

1.9

GENERAL

A sufficient quantity of hardware and neoprene gaskets is supplied with the antenna to effect an airtight assembly of the coaxial line to the antenna element line blocks. It is advisable to apply a small quantity of non-melting silicone dielectric lubricant (such as Dow-Corning No. 4 Compound) sparingly to the neoprene gaskets during assembly.

NOTE: *To insure a proper antenna installation, care must be exercised to see that no undue stress is placed on the antenna elements which might bend or distort them. When the installation is completed, the sections of interconnecting coaxial cable between antenna bays and the antenna elements should all be in alignment respectively.*

1.10

The Low Power Antenna has been carefully assembled and pretuned to the station's operating frequency before leaving the Gates factory. The input impedance is 50 ohms. Adjustments have been made to obtain the optimum VSWR at the station's frequency with the entire antenna assembled. Tests have also been conducted, using air pressure, to insure that the antenna system is free from gas leaks.

SECTION 2 - EXAMINATION PRIOR TO OPERATION

- 2.1 The transmission line and antenna system should be purged prior to placing the system in service, or at any other time that moist air may enter the line. This is accomplished by pressurizing the line at the transmitter end to approximately 5 to 10 lbs. / sq. in. The system may now be bled by temporarily loosening the four bolts in the brass plate on the top of the upper most antenna line block. Retighten the four bolts to seal the system and repressurize. Repeat this procedure three times to assure complete purging.

NOTE: *Leaks in a transmission line are often audible, if the leak is large and the line is under sufficient pressure (approximately 15 lbs. P.S.I.). Small leaks may be located by the use of bubble liquid which may be brushed on the suspected leak areas.*

- 2.2 After purging the transmission line feeding the antenna system should be kept filled with dry air or nitrogen at a pressure of 3 to 5 pounds per square inch. There is no advantage in pressurizing the system in excess of 5 lbs. / sq. in. However, the system should be pressurized so that changes in temperature will not cause moisture condensation from outside air, thereby impairing the electrical efficiency of the antenna system.

- 2.3 The antenna elements and transmission line do not require painting. Only the antenna brackets require painting:

NOTE: *Should any of the antenna elements ever be painted, care should be taken to keep the paint off the insulated surfaces.*

SECTION 3 - TECHNICAL DATA

ELECTRICAL

Frequency Range:	Factory tuned to one specific frequency in the 88-108 MHz band.
Polarization:	Circular, clockwise.
Free Space Pattern:	Horizontal component circular ± 2 dB. Vertical component circular ± 2 dB.
Vertical to Horizontal Ratio:	Fixed at 1 to 1.
VSWR:	1.2 to 1 or better ± 200 kHz as tuned at the factory. VSWR when tower mounted 1.5 to 1 or better ± 200 kHz Capable of adjustment to 1.1 to 1 ± 100 kHz with field tuning.
Power Gain:	Horizontal polarization: See table. Vertical polarization: See table.
Power Input Rating:	Maximum of 5 kW for two to six bays. 3 kW for single bay.
Input Connection:	A six foot transformer section is provided on the bottom of each antenna system which has a 1 - 5/8" 50 ohm EIA female connector.

MECHANICAL

Windload:	Designed for 50 psf for flat surfaces, 33 psf for cylindrical surfaces.
Weight:	Single bay 27 lbs., less brackets. 1 - 5/8" interbay coaxial line weighs approximately 10 lbs. per section.
Dimensions:	Height approximately 42". Length approximately 16".

TABLE 3.1
TECHNICAL DATA FOR MULTIPLE BAY INSTALLATIONS

GATES TYPE	POWER GAIN		dB GAIN		FIELD GAIN ¹		POWER RATING	APPROX. ² LENGTH	WEIGHT ³ (lbs.)	WIND ⁴ LOAD
	Horizontal	Vertical	Horizontal	Vertical	Horizontal	Vertical				
FMC-1A	0.438	0.438	-3.585	-3.585	0.662	0.662	3 kW		24	54
FMC-2A	0.947	0.947	-0.237	-0.237	0.973	0.973	5 kW	10	53	126
FMC-3A	1.480	1.480	1.702	1.702	1.216	1.216	5 kW	20	81	198
FMC-4A	2.025	2.025	3.064	3.064	1.423	1.423	5 kW	30	110	271
FMC-5A	2.577	2.577	4.111	4.111	1.605	1.605	5 kW	40	138	343
FMC-6A	3.134	3.134	4.961	4.961	1.770	1.770	5 kW	50	167	414
FMC-7A	3.695	3.695	5.676	5.676	1.922	1.922	5 kW	60	196	486
FMC-8A	4.258	4.258	6.292	6.292	2.063	2.063	5 kW	70	225	558

1. To obtain the effective free space field intensity at one mile in MV/M for one kilowatt antenna power, multiply field gain by 137.6.
2. When determining coax length, add six feet to antenna length.
3. The weights given are less brackets, but the interbay transmission line and transformer section are all included in the weight.
4. Windload based on 50 psf on flat surfaces and 33 psf for cylindrical surfaces (actual wind velocity 110 mph). Computed for a 100 MHz antenna less mounting brackets and less heater junction boxes and heater cables.

BY *L. Jee* DATE *5/10/22*
CHKD. BY _____ DATE _____

SUBJECT *WISS - FM*
102.3 MHz
BERLN, Wisc.

SHEET NO _____ OF _____
JOB NO. *Fm CP-101A*

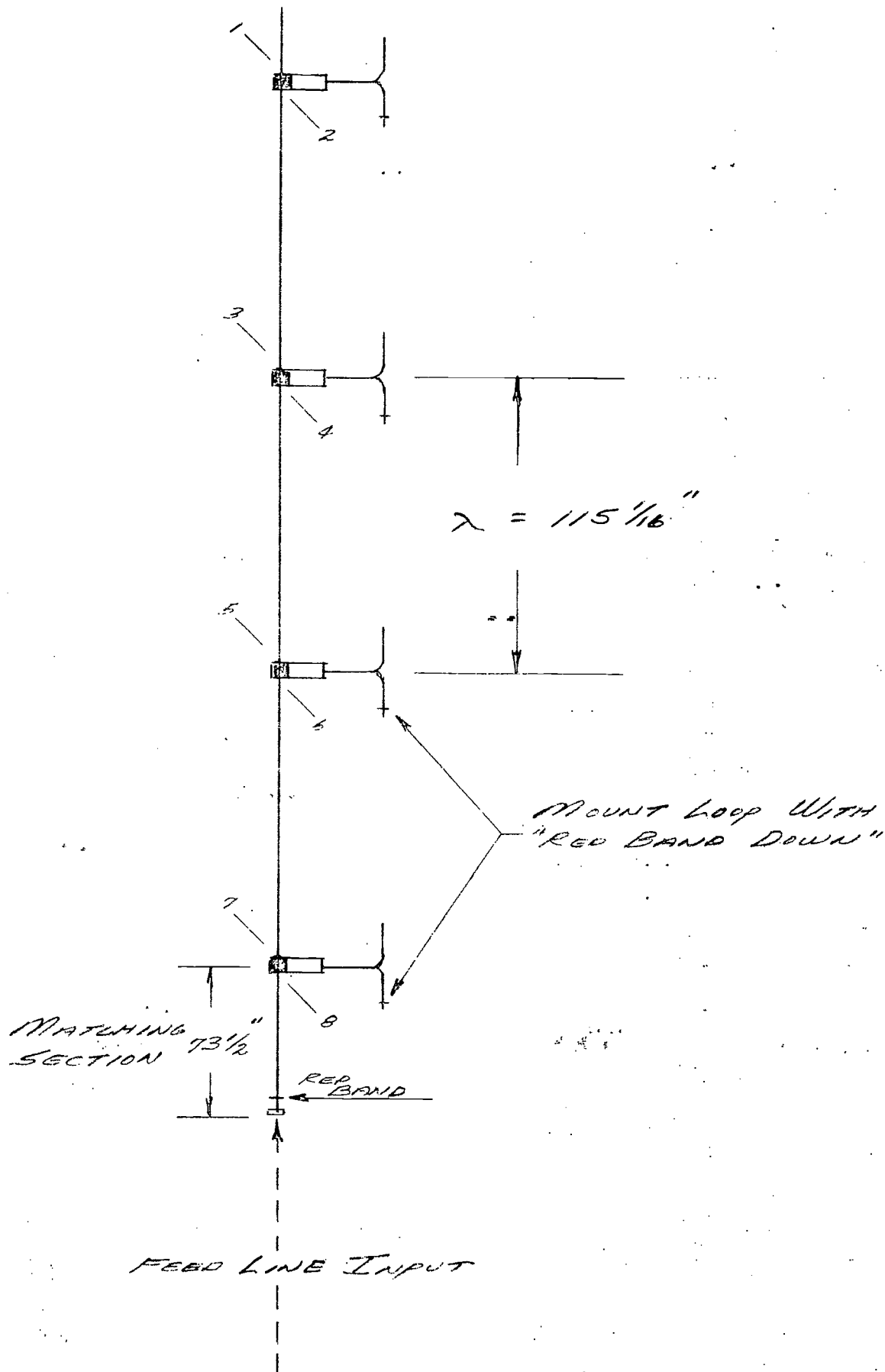

BY L. Lee DATE 5/10/72

SUBJECT WISS - FM

SHEET NO. _____ OF _____

CHKD. BY _____ DATE _____

102.3 MHz

JOB NO. _____

BERLIN, Wis.

FMCP-181A

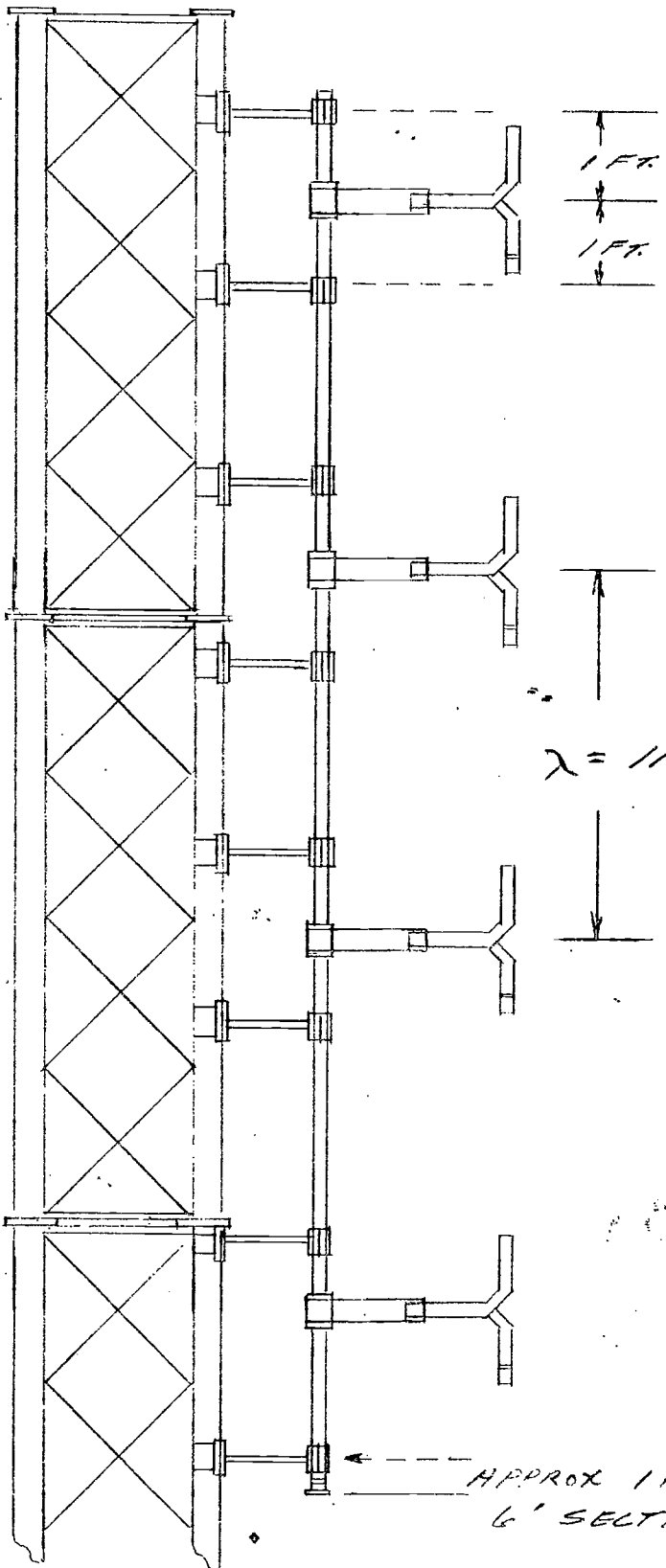
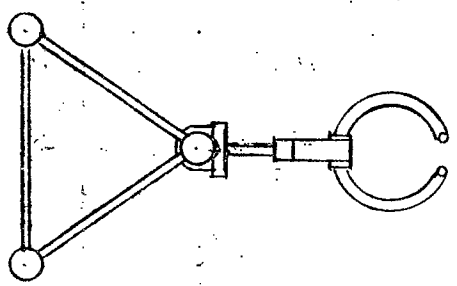

$$\lambda = 115 \frac{1}{16}''$$

APPROX 1 FT. FROM BOTTOM
6' SECTION

ELECTRONICS RESEARCH, INC., EVANSVILLE . 4 . INDIANA

INSTRUCTIONS FOR CHANGING HEATERS IN CIRCULAR

POLARIZED FM ANTENNAS

1. Remove heater box lid. Disconnect heater wires from terminal block. With ohm meter, check resistance across the wires of each heater to determine if they are working. This should measure between 70 and 80 ohms if heater is working.
2. If heater is bad, remove copper tubing at heater box, then remove antenna rings from balun. This should permit wires to be pulled from heater box.
3. Remove copper tube from loop, take brass fitting out of antenna loop. Thread heater wire back through the hole where fitting was removed and into hole in center of flange. This will allow heater to be pulled straight out of loop.
4. With needle nose pliers twist heater slightly while pulling out. This will help heater slide around radius of loop.
5. After heater is removed take new heater and push it into antenna loop twisting slightly back and forth to help heater bend around radius of loop.
6. Thread heater wire back through 7/16" hole in flange. Replace fitting in its proper place and remount loop on balun in normal position. Put copper tubes in place and thread heater wire back into heater box and tighten all connections.
7. Wire heater in parallel, place wires in terminal block across normal position and replace heater box lid.

300 WATT HEATERS

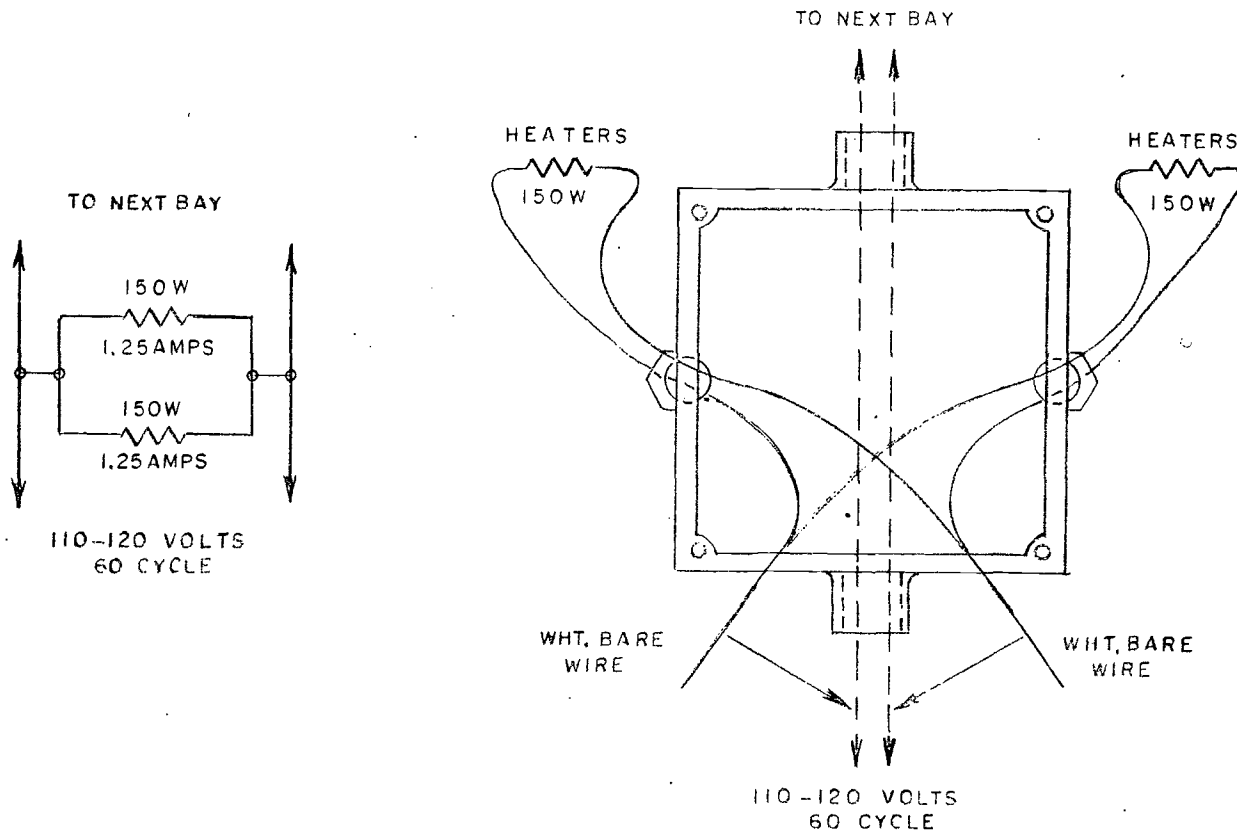

The two bare wires indicated extending from the junction box are to be connected parallel across the 110-120 volt line. In checking for continuity of heaters, any reliable multimeter that will measure between 0-100 ohms will be sufficient. Single heaters should measure 75 ohms, two in parallel will be half of this, approximately 37 ohms.

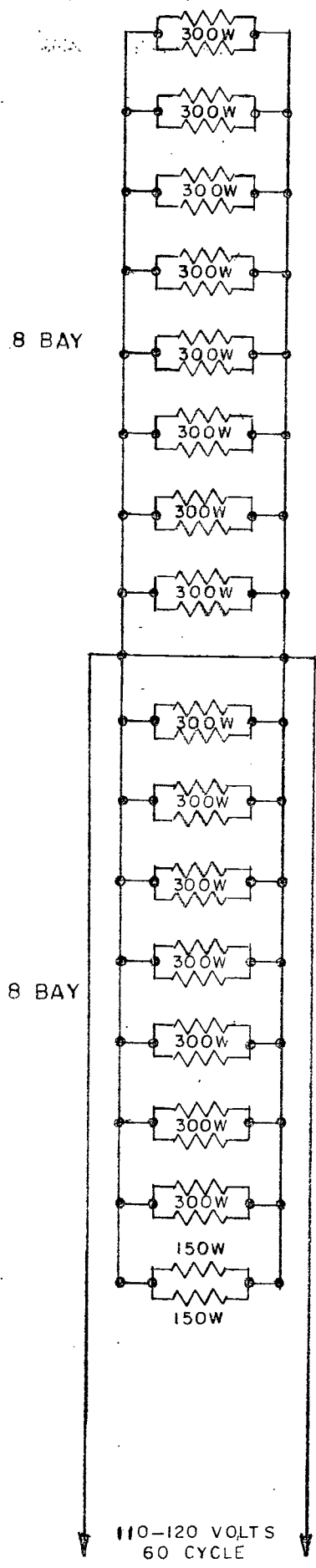

300 Watt Heaters Each Element rated 150 Watts at 120 V				
No. of Bays	Watts	Volts	Cold Amps.	Hot Amps.
1	300	120	2.5	2.7
2	300	120	5.0	5.5
3	300	120	7.5	8.1
4	300	120	10.0	10.9
5	300	120	12.5	13.6
6	300	120	15.0	16.3
7	300	120	17.5	19.1
8	300	120	20.0	21.8
9	300	120	22.5	24.5
10	300	120	25.0	27.2
11	300	120	27.5	30.0
12	300	120	30.0	32.7
13	300	120	32.5	35.4
14	300	120	35.0	38.1
15	300	120	37.5	40.9
16	300	120	40.0	43.6

Note: Interbay cable rated at 25 amps., therefore antenna with more than eight bays must have A.C. voltage fed at center of antenna to avoid overheating in electrical cable.

BY: L. Ice DATE 12-6-67

SUBJECT Circular Polarized Heater
Drawing - For use with
insulated cable

SHEET NO. OF

CHKD BY DATE

JOB NO.

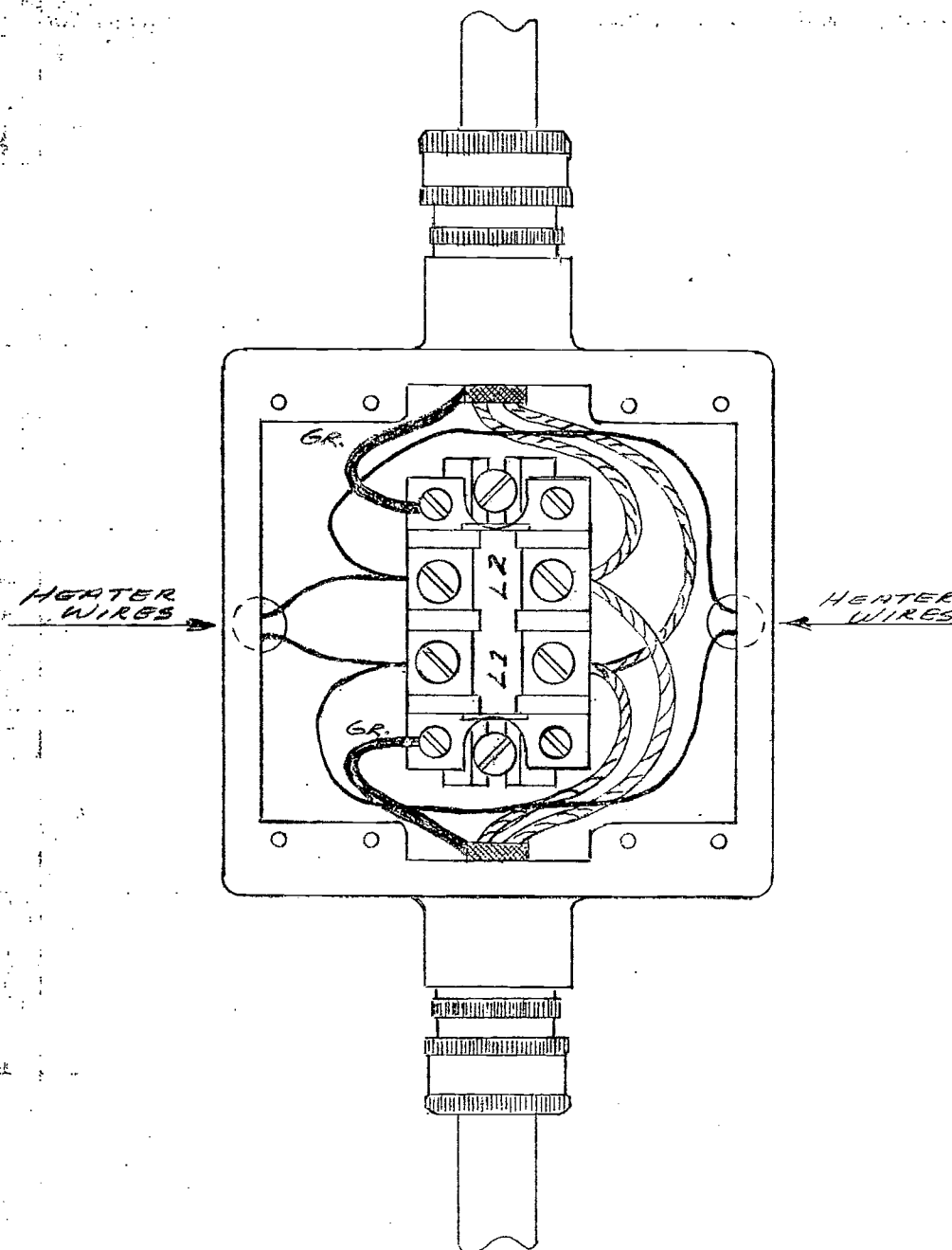

Remove male portion of connectors from cable and screw into junction box.

Insert cable into junction box and tighten connector nut.

Connect upper and lower line wires across L1 and L2.
Connect heaters to opposite side of terminal block across L1 and L2.

BRACKET COATING

The antenna mounting brackets supplied with the antenna are made of structural steel. After fabrication the brackets are cleaned and then brush painted with two coats of Devcon Z paint. This paint gives a gray matte finish and provides an effective corrosion resistant treatment.

Devcon Z paint is 95% pure zinc and 5% epoxy binders. The two coats of this paint will lay down approximately one ounce of pure zinc per square foot, which is more zinc protection than normally afforded by standard hot dip galvanizing.

The Devcon Z protects the steel by sealing out moisture and also prevents corrosion by galvanic action. If the Devcon Z is scratched through to the steel, the zinc in the presence of moisture forms a galvanic cell with the steel. The zinc (anode), because of its position in the galvanic series, will sacrifice itself to protect the base metal of steel (cathode). This protection will continue as long as zinc is present. The zinc sacrificed forms an insoluble zinc oxide layer on the scratched or exposed metal and thus protects against further corrosion.

Due to the high zinc content of the Devcon Z paint, the surface is highly conductive electrically. This assures good electrical contact between the antenna and the support pole or tower, assuming the brackets make good electrical contact with the bare metal of the pole or tower.

It is recommended that the brackets be painted each time the tower is painted. The regular tower paint may be used on the brackets, thereby, affording added protection to the steel brackets.

HARRIS
INTERTYPE
CORPORATION

GATES[®]

A DIVISION OF HARRIS-INTERTYPE

123 HAMPSHIRE ST. • QUINCY, ILLINOIS • 62301 • U.S.A.