

**TECHNICAL
MANUAL**

FM-1B 1KW FM TRANSMITTER

**HARRIS
INTERTYPE
CORPORATION**

GATES[®]

A DIVISION OF HARRIS-INTERTYPE

WARRANTY

Seller warrants new equipment manufactured by Gates Radio Company against defects in material or workmanship at the time for delivery thereof, that develop under normal use within a period of one year (6 months on moving parts) from the date of shipment, of which Purchaser gives Seller prompt written notice. Other manufacturers' equipment, if any, including electron tubes, and towers shall carry only such manufacturers' standard warranty.

Seller's sole responsibility for any breach of the foregoing provision of this contract, with respect to any equipment or parts not conforming to the warranty or the description herein contained, is at its option, (a) to repair or replace such equipment or parts upon the return thereof f.o.b. Seller's factory within the period aforesaid, or (b) to accept the return thereof f.o.b. Purchaser's point of installation, whereupon Seller shall either (1) issue a credit to Purchaser's account hereunder in an amount equal to an equitable portion of the total contract price, without interest, or (2) if the total contract price has been paid, refund to Purchaser an equitable portion thereof, without interest.

If the Equipment is described as used, it is sold as is and where is. If the contract covers equipment not owned by Seller at this date it is sold subject to Seller's acquisition of possession and title.

Seller assumes no responsibility for design characteristics of special equipment manufactured to specifications supplied by or on behalf of Purchaser.

Seller shall not be liable for any expense whether for repairs, replacements, material, service or otherwise, incurred by Purchaser or modifications made by Purchaser to the Equipment without prior written consent of Seller.

EXCEPT AS SET FORTH HEREIN, AND EXCEPT AS TO TITLE, THERE ARE NO WARRANTIES, OR ANY AFFIRMATIONS OF FACT OR PROMISES BY SELLER, WITH REFERENCE TO THE EQUIPMENT, OR TO MERCHANTABILITY, INFRINGEMENT, OR OTHERWISE, WHICH EXTEND BEYOND THE DESCRIPTION OF THE EQUIPMENT ON THE FACE HEREOF.

RETURNS AND EXCHANGES

Do not return any merchandise without our written approval and Return Authorization. We will provide special shipping instructions and a code number that will assure proper handling and prompt issuance of credit. Please furnish complete details as to circumstances and reasons when requesting return of merchandise. Custom built equipment or merchandise specially ordered for you is not returnable. Where return is at the request of, or for the convenience of the customer, a restocking fee of 15% will be charged. All returned merchandise must be sent freight prepaid and properly insured by the customer. When writing to Gates Radio Company about your order, it will be helpful if you specify the Gates Factory Order Number or Invoice Number.

WARRANTY ADJUSTMENTS

In the event of equipment failure during the warranty period, replacement or repair parts may be provided in accordance with the provisions of the Gates Warranty. In most cases you will be required to return the defective merchandise or part to Gates f.o.b. Quincy, Illinois for replacement or repair. Cost of repair parts or replacement merchandise will be billed to your account at the time of shipment and compensating credit will be issued to offset the charge when the defective items are returned.

MODIFICATIONS

Gates reserves the right to modify the design and specifications of the equipment shown in this catalog without notice or to withdraw any item from sale provided, however, that any modifications shall not adversely affect the performance of the equipment so modified.

INSTRUCTIONS FOR INSTALLING AND OPERATING

GATES FM-1B TRANSMITTER, M5597

I.B. #888 0593 001
4/26/61.

Gates Radio Company
quincy, Illinois

ADDENDUM

FM - 1C

POSITION OF ANODE CONNECTOR STRAP

The position of the anode connector straps in relation to the plate lines will effect the frequency at which the plate will tune. If difficulty in getting the plate to hit frequency is experienced with the shorting bar at its factory setting, these straps should be dressed differently until plate will tune. (Closer to lines will raise frequency.)

REFERENCE: PAGE 5, FIRST PARAGRAPH

With reference to grid voltage measurement at TP401, the test point on the driver panel, this voltage will be approximately 10-20 volts with voltages removed from the driver unit. This is accomplished by removing the plug on the 600 volt rectifier stack on the 600 volt supply.

BE SURE THE ENTIRE TRANSMITTER IS TURNED OFF BEFORE REMOVING THIS PLUG.

REMOTE CONTROL

All remote control metering and OFF-ON functions are built into the FM-1C. All that is necessary to completely remote control the transmitter is the addition of the motor driven rheostat (M4703C), which will be supplied on special order.

6/11/62

Gates Radio Company
Quincy, Illinois

107.3
 2
 214.6

FM HARMONICS IN THE TV BAND

The sharp upsurge in FM broadcasting has in some instances developed unlooked for interference with local TV reception. In every instance this interference is in so-called fringe areas for TV reception and where the strength of the TV signal is weak enough that outside highly directional home TV antennas are necessary. --- When this condition develops, the TV viewer quickly learns from his service man that the local FM station is the offender. ---- The FM broadcaster is immediately deluged with requests to eliminate the interference. In some instances CATV (Community Antenna Television) systems are also offended as they pick up weak distant TV stations. ----- What is the FM broadcaster's responsibility? Answer: To meet FCC rules and regulations as related to harmonic radiation of his FM equipment but not to guarantee perfect TV reception.

Below is a chart showing the picture and sound frequencies of TV stations between Channels 7-13 inclusive. Channels 2-6 are not shown. FM harmonics do not fall in these Channels. In fact, commercial FM station harmonics will affect only Channels 8 and above ---- look at the chart.

<u>TV Channel</u>	<u>Picture Frequency Band ---Mc---</u>	<u>Sound Frequency</u>
7	175.25 to 179.50	197.75
8	181.25 to 185.50	185.75
9	187.25 to 191.50	191.75
10	193.25 to 197.50	197.75
11	199.25 to 203.50	203.75
12	205.25 to 209.50	209.75
13	211.25 to 215.50	215.75

The frequency range for commercial FM broadcasting is 92.1 Mc to 107.9 Mc: --- To determine the second harmonic of your FM frequency, just multiply your frequency by 2. Example: If your frequency is 99.9 Mc, multiplied by 2 would make a second harmonic of 199.8 Mc. By consulting the above chart, you will note the second harmonic falls in the picture portion of the TV Channel 11.

Correct FM Harmonic Radiation

The FCC stipulates that transmitters of 3000 watts power and over must have a harmonic attenuation of 80 db. For 1000 watts, 73 db., and for 250 watts, 66.9 db. All reputable manufacturers design their FM transmitters to meet or exceed these specifications.

Fringe Area TV Strength Versus FM Harmonics

Let's take a typical FM station that radiates 70,000 microvolts per meter at 1 mile. At 80 db. harmonic attenuation (as called for by FCC), this station will radiate approximately 7 microvolts per meter at 1 mile on the second harmonic. In the case of our Channel 11 example, it is estimated that a fringe area TV station from 60 to 90 miles distance would have a signal strength of from 5 to 25 microvolts per meter. It can then be easily understood that a 7 microvolt signal, well within FCC specifications, would definitely interfere with the TV signal, yet with the FM broadcaster's equipment performing normally.

This is sometimes further aggravated by the FM station being located between the TV station and the TV receivers. In this instance the TV antennas are focussed not only on the TV station but your FM station as well. The home TV antennas are beamed at your legal second harmonic as well as the fringe TV station.

What To Do

When interference occurs, it will develop ragged horizontal lines on the TV picture varying with the FM program content. If the TV sound portion is interfered with (usually not the case), then the FM signal will be heard in addition to the TV sound.

1. It is not up to the FM broadcaster to go on the defensive. He did not put the TV station 75 miles away nor did he select the TV Channel. ---- In most instances the condition is a natural phenomena that neither you, the TV station, nor the FCC can correct.
2. Do not adjust the FM harmonic or "T" notch filters supplied with the FM transmitter. These are factory adjusted and most FM stations do not have the expensive equipment necessary for correct adjustment. Tampering with this calibrated adjustment will probably make the condition worse.
3. Do not rely on TV service men's types of measuring equipment. They are not built to accurately measure harmonics and invariably give erroneous readings that invite the CATV or local service men's association to say "I told you so." Remember it is difficult to radiate harmonics if the equipment is built to suppress the harmonics and it is.
4. In many instances interference may be caused by overloading on the front end of the TV receiver. This problem usually occurs when the receiver is located close to the FM transmitter. This problem can be overcome by installing a trap tuned to the frequency of the FM carrier. The TV service man can and must learn how to do this. In most cases it works, while in some instances, if not properly installed or tuned, it will not completely eliminate the interference. In one case where interference of this type existed, a TV station put traps for the fundamental FM frequency on nearly every TV set in town. Not the FM transmitter.

Summary

The FCC is well acquainted with this nation-wide problem. If TV viewers write FCC, complaining about your FM station, remember the FCC has received a few thousand similar letters. ----- It is not the obligation of the FM broadcaster to assure fringe area reception of a TV station any more than is the obligation of the TV station to assure the FM broadcaster perfect reception in his TV city.

Probably your installation will not have problems as outlined above. If they do exist, don't blame the equipment. Every transmitting device puts out a second harmonic, even the TV stations. The fact that these harmonics legally fall into the spectrum of a TV station many miles distant is coincidental, but not your fault.

Gates Radio Company

INDEX

	Page
SPECIFICATIONS	1
DESCRIPTION	2
THEORY OF OPERATION	3
UNPACKING AND READYING FOR OPERATION	4
INSTALLATION	4
OPERATING AND TUNE UP PROCEDURE	5
NEUTRALIZATION	6
GENERAL INFORMATION	8
MICROMATCH OPERATION	9
REMOTE CONTROL	9
MAINTENANCE	10
PARTS LIST	
GUARANTEE	
PHOTOS	
813 6026 001	
DRAWINGS:	
813 5901 001 Filter Installation	
813 5904 001 Remote Control wiring - RDC-200A.	
813 5903 001 Remote Control wiring - RDC-10C.	
A-31735-1 Micromatch Cap Assy. and Schematic.	
A-31735-2 Micromatch Cap Assy. and Schematic.	
B-65503 Schematic, Power Supply	
B-67314-1 Recycle Unit Schematic	
C-79128 Base Layout Information	
D-23115 Overall Schematic	
D-23127 Internal Wiring	
M5534 EXCITER INSTRUCTION BOOK	
M5675 50 WATT AMPLIFIER INSTRUCTION BOOK	
M5737 FILTER INSTRUCTIONS	
M6023 AUTOMATIC RECYCLE UNIT INSTRUCTIONS	
FACTORY TEST DATA SHEETS.	

4/26/61

-1-

FM-1B, M5597

SPECIFICATIONS

FM-1B M5597

Power Output: 1000 Watts

Frequency Range: 88 to 108 MC.

R.F. Output Impedance: 50 ohms

Type of Oscillator: Direct Crystal Controlled

Frequency Stability: \pm .001%

Type of Modulation: Phase shift employing pulse techniques

Modulation Capability: \pm 100 KC
 \pm 75 KC considered 100% modulation

Audio Input Impedance: 600 ohms

Audio Input Level for 100% Modulation: \pm 10 DBM \pm 2 db

Frequency Responses: Within 1.0 db of standard 75 micro-second pre-emphasis curve, or flat \pm 1.0 db 50 to 15,000 cycles whichever is desired. (specify)

Distortion at 100% Modulation: 1% or less 50 to 100 cycles
.5% or less 100 to 10,000 cycles
1% or less 10,000 to 15,000 cycles

Noise: 65 db below 100% modulation (FM)
50 db below equivalent 100% (AM) modulation

Power Input: 230 volts, 50/60 cycles, single phase three wire, 5 KVA demand, 115 volts, 50/60 cycles single phase, 500-watts.

Tubes:

7 - 6AU6	2 - 673
4 - 12AX7	1 - 6360
3 - 6J6	1 - 6AQ5
2 - 0A2	1 - 6080
2 - 6146	1 - GZ34/5AR4
2 - 4-400A	1 - 5R4GYA
1 - 12AT7	

R.F. Output Connector: 7/8 inch coax flange

Size: Width - 24 in. (less end bells), 27 in. (with end bells), Height - 78 in.
Depth - 36 $\frac{1}{2}$ inch.

Weight: Packed - 1140 lbs. Net 880 lbs.

Cubage: 34 cu. ft. unpacked

4/26/61

-1-

FM-1B, M5597

DESCRIPTION

The Gates FM-1B frequency modulated broadcast transmitter will provide 1000 Watts of frequency modulated power to a properly designed antenna and transmission line system on any frequency from 88 to 108 Mc. Characteristics obtained, in any proper installation, will exceed those required by the FCC for FM broadcast service.

The basic units of the FM-1B are: exciter, driver and power amplifier.

- a) The exciter unit (M5534) is capable of 10 watts output and is the basic exciter used in all of Gates FM equipment.
- b) The driver unit (M5675) is capable of 50 watts output and is link coupled to the input of the power amplifier.
- c) The power amplifier of the FM-1B consists of two 4-400A power tetrodes operated in a push-pull circuit. Quarter-wave lines are employed in the plate circuit for maximum stability and efficiency.

The M5534 exciter used in this transmitter employs a phase shift modulator with pulse timing techniques and may be adapted to single or dual channel multiplexing on a plug-in basis, with blank panel space provided for the addition of the multiplex unit.

An important feature of this transmitter is the lack of frequency multiplication after the exciter. This aids in helping to eliminate spurious frequencies and gives protection to tube life, as power type tubes in doubling or tripling operation are not always operated at their most stable life lengthening conditions.

Mechanically the FM-1B has been designed to be easily maintained. Ready accessibility to all parts is accomplished by lift-off type doors. The sides of the cabinet may be easily removed by removing two screws from the holding bracket from the bottom of the side panels and lifting the side panels off.

The control panel for the FM-1B consists of the OFF-ON switches, for the line voltages, the OFF-ON switches for the plate voltage, various indicator lights, the local remote switch, the tune operate switch and the overload reset switch.

The meter panel for the FM-1B is hinged and may be lifted up by first loosening the fastener one quarter turn using a screwdriver or a coin and then lifting the meter panel up. This will give access to meter terminals and wiring of the reflectometer or Micromatch switching section.

THEORY OF OPERATION

With the pressing of S502 the low voltage ON button, primary voltage is applied to the exciter, the blower, the fan and the low voltage power supply. Filament voltage is also applied to both PA tubes, rectifier tubes, and voltage is applied to the control circuitry. The exciter has its own power supply and DC voltage is applied to the exciter when its power supply comes up to operating temperature. The exciter power supply also supplies voltage for the driver screen. The low voltage supply supplies voltages for the driver plate and the amplifier screen. With switch S512 in the grid position, about a minute after S502 is pressed grid current will appear on the PA grid current meter, which is the second meter from the left on the cabinet meter panel. This meter should indicate 16 to 25 mils of grid current.

The low voltage power supply also supplies the screen voltage for the power amplifier, however, the DC path is broken through a set of contacts on K503, which is the high voltage contactor. By pressing the high voltage ON button S506 both plate and screen voltage are applied to the power amplifier.

The function of S518 is a "local-remote" switch, with the switch in the "remote" position the fail-safe relay in the remote control unit acts as the holding contacts for K501, which is the line contactor. With S518 in the "local" position the holding contacts on K501 are operative and the remote control unit is disconnected from the transmitter.

The function of S519 is the "tune operate" switch. In "tune" position S519 disables the automatic recycling unit so the transmitter is on complete manual control. The theory and operation of the automatic recycling unit is covered in a separate set of instructions which are part of this instruction book.

The function of S517 "overload reset" is the resetting of the plate overload relay K505. If S519 is in the "tune" position the transmitter experiences an overload, S517 must be pressed to reset K505 before plate voltage can again be applied to the amplifier. Overload relay K505 is in a "lock out" type of circuit. If S519 is in the "operate" position the resetting of the plate overload is automatically taken care of in the recycling unit.

To multiplex the Gates FM-1B is a relatively simple matter. The main channel exciter was specifically designed with multiplex in mind. Space has been provided directly below the exciter for the placing of the multiplex unit. A minimum amount of connections are necessary to connect this unit to the main channel exciter. Connections necessary are a coax connector to the multiplex exciter in the multiplex chain. This is done on the front panel of the two units. Other connections necessary are power from 115 volt source. This can be taken off 115 volt terminals of

the main channel exciter and the connecting of the audio to the terminal board on the multiplex unit completes the necessary wiring. The multiplex unit is capable of handling two sub-channels and, therefore, there are two audio input terminal arrangements available on the terminal board of the multiplex unit.

Since the power contactors are non-circuit breaker types, they require a momentary ON and a momentary OFF type of function to operate them, the transmitter is easily remote controlled.

UNPACKING AND READYING FOR OPERATION

The FM-1B is carefully checked and packed at the Gates plant to assure that safe arrival at its destination in proper electrical and mechanical condition.

Tests of many different kinds are made at the factory and the unit is operated for several hours to assure correct adjustment and proper operating conditions.

Certain large components are removed from the unit and shipped separate to assure safe handling. The components removed are: T501, L501, L502, C501 and C502. Wires are numbered or tagged as a guide for replacement of these parts. Photographs are supplied to assist in the proper placement and orientation of the components that have been removed for shipment.

After the FM-1B has been received and unpacked, it should be carefully inspected for any mechanical damage. If any damage is noticed to any section of the equipment, a claim should be filed immediately with the delivering transportation company and necessary replacement items ordered from the Gates Radio Company.

It is a good precautionary practice to completely go over the equipment to check for loose connections, loose components, broken insulators, etc., that might have become loosened or damaged in shipment. Make sure all relay contacts are free and in good mechanical operation. Make sure all mechanical connections are tight.

The power contactors are either tied down or blocked sufficiently to keep them from vibrating during shipment. These should be checked and the shipping material removed.

A good overall visual inspection may save much time later in getting the transmitter to operate correctly.

INSTALLATION

In advance of actual placement and adjustment of the transmitter certain preliminary planning should be done. The use of drawing C-79128 and 813 5901 001 will assist in locating the power and audio input leads and the power output from the transmitter.

4/26/61.

-4-

FM-1B, M5597

The following should be arranged in advance of actual installation work.

1. Leads from a low reactance power source of 230 volts, 60 cycle, single phase and 115 volts, single phase, 60 cycle AC lines should be run in conduit underneath the proposed location or platform.

The wires should be at least #6 for 230 volts, 60 cycle, single phase and #12 for the 115 volts, 60 cycle, single phase for best regulation.

Running these power sources in lead enclosed wires or in a steel conduit is highly recommended to obtain both audio and radio frequency shielding near the transmitter.

2. To assist in keeping RF currents in nearby audio equipment to a minimum, a good ground at these frequencies is mandatory. One of the best known methods of doing this, is the installation of a sheet of copper for the ground system beneath the complete transmitter layout. RF usually shows up in one or both of two ways, feedback or high noise level. It should be pointed out that even a small amount of wire unshielded is a very effective antenna at FM frequencies in transferring RF to the grid where it is rectified and passed on as noise or feedback. It is preferable to have a single common ground point from the transmitter copper shield to a good ground.

OPERATING AND TUNE UP PROCEDURE

Before attempting to tune the transmitter, make sure it is connected to a transmission line and antenna that will present a nominal load of 50 ohms or a non-reactive load with the proper power handling capabilities.

Before tuning the transmitter, refer to the factory test data sheets and check all dial readings to correspond with the data given on the factory test data sheets.

Switch S518 should be in the "local" position, switch S519 should be in the "tune" position.

After the installation is complete all input and output cables have been connected and the crystal oven has been operating for two hours or more punching the low voltage "ON" button applies primary voltages to all of the filaments, control circuits, the fan, the blower and the low voltage power supplies. Provision

is made on the driver panel for metering the grid bias voltage of the driver by means of a test point on the front panel. A meter such as a Simpson Model 260 or equivalent may be used. With the negative lead plugged into this test point and the positive lead grounded, a rise in grid voltage will be observed as the exciter comes up to operating temperature. This voltage should be approximately 15 to 20 volts. This is a good check on the exciter operation. Place switch S512 which is the test meter switch located on the bottom center of the amplifier panel, in the grid position, which is extreme counterclockwise. Tune the grid circuit to resonance with control marked "grid tuning" and observe grid current on M502, this should be approximately 16 to 25 mils of grid current.

Press the high voltage ON button and tune the amplifier to resonance with the control marked "plate tune" and observe plate current on meter M503. It may be necessary to go back and re-resonate the grid circuit after high voltage is applied.

Load the amplifier to the required power by the control marked "RF output" turning control clockwise increases loading and counterclockwise decreases loading. Observe power output on meter M505 which has been calibrated at the factory and reads power being delivered out of the transmitter to the transmission line. This meter has been calibrated and its calibrating controls locked in place and should not be tampered without express authorization from the Gates Radio Company.

NEUTRALIZATION

Tuning of an FM transmitter in the frequency range of 88 to 108 Mcs, offers greater difficulties in regard to tuning various circuits than is normally encountered in the lower AM frequencies. This is manifest in greater reaction between various circuits caused by small inductive and capacitive reactances that can normally be ignored at the lower frequencies, but which can become increasingly important at these high frequencies. Therefore, when tuning a high frequency transmitter, it is well to constantly re-check the previous adjustments as tuning progresses.

The transmitter has been properly neutralized at the factory on the customer's frequency with a 50 ohm non-reactive load. Due to rough handling during shipment neutralization may be affected. Improper neutralization is indicated by several abnormal conditions showing up in the operation.

1. When the grid current does not rise to maximum or near maximum simultaneously with a dip in plate current as the amplifier plate tank is tuned through resonance.
2. If excitation is removed from the amplifier and the PA grid relay does not open, this indicates oscillation in the power amplifier itself. This

self-oscillation produces grid current which holds the grid relay K506 closed, this keeps the plate voltage applied allowing the amplifier to continue its self-oscillation.

3. If the balance control R504 and R505 does not enable the two plate currents to maintain a balance within 10%, this condition will indicate improper neutralization.
4. A radical change in PA grid current from the value given on the factory test data sheet.
5. Spurious radiation detected across the band.

The neutralizing controls have been brought out to the front panel of the amplifier to a special machined bushing. In the center of this special bushing is a shaft with a machined screwdriver slot. It will be noted that on both this special bushing and the internal screwdriver slot shaft, there are two black dots. These two dots are aligned in a vertical position when the neutralizing capacitors are at maximum capacity.

It will also be noted that on this special bushing is a red dot which will appear directly opposite the black dot on the movable portion of the shaft. This red dot, on the special machined bushing, indicates the location of the neutralizing capacitors as they were set at the factory. These marks will serve as a good starting place if complete re-neutralization is required.

If any of the aforementioned conditions are observed when the transmitter is first placed in operation, this indicates that re-neutralization is in order. This is accomplished as follows:

1. Turn the high voltage OFF.
2. Remove the bottom cover from the PA tank.
3. Loosen the locking nuts on the rear of the neutralizing capacitor slightly, so that the capacitor shaft will turn free with a slight drag on the shaft.
4. Remove one of the plate caps from the high voltage rectifier, so as to reduce the plate voltage.
5. Replace the bottom cover plate on the amplifier tank.
6. Apply low plate voltage and adjust either C303 or C308 in one direction and again check for neutralization.

7. If improvement results, adjust the other capacitor the same amount in the same direction and again re-check for neutralization.
8. Continue this procedure step-by-step rotating capacitor C303 and C308 in the direction that indicates the proper neutralization.
9. Replace the cap removed on the high voltage rectifier for normal operation and re-check neutralization.
10. Remove the bottom cover of the amplifier tank and re-tighten the locking nuts on the rear of the neutralizing capacitors, being careful not to move the adjustment while these locking nuts are being tightened.

GENERAL INFORMATION

There are some facts about the power amplifier that should be known and remembered that will help in good operation of the equipment and contribute to best operating results.

Tuning of the plate circuit changes the effective electrical length of the plate tank. Increasing the spacing between the tuning and the plate tank lines lengthens the effective length of the plate tank and lowers the frequency; decreasing the spacing will raise the frequency.

Switch S510 located on the power amplifier panel in the lower left hand corner is provided for checking individual cathode currents of V301 and V302 as well as the total plate current on both these tubes.

The balance control R504 and R505 is provided on the front panel to enable the operator to maintain a balance in plate currents.

S510 is used for relative balance indication of plate currents. This switch must be left in the normal or mid-position while the transmitter is operating, except on initial tune up or for checking balance between plate currents of the tubes. S512 is a multimeter switch which is used to read either total control grid current or individual screen grid currents of V301 and V302.

Protection against electrical shock from high voltage circuits are provided for by the door interlock switch S514. By removing the back door, S514 will open and immediately remove the high voltage from the amplifier. Forced air is provided for the amplifier tubes by a blower B301. B501 is provided to exhaust any hot air in the cabinet proper.

MICROMATCH OPERATION

On Drawing A-31735-2 is a complete schematic of the internal wiring for the Micromatch unit. The following is a description of this unit as used with the FM-1B transmitter.

On the Micromatch switching panel there are two controls which adjust the calibrating of the unit and a switch. One control has a knob which is the VSWR calibrating control, the other has a shaft lock. The control with the shaft lock adjusts the calibrating of the power function and is set at the factory and needs no further adjustment. The other control with the knob adjusts the calibration of the VSWR.

To calibrate the VSWR portion of the unit turn the switch to calibrate position and adjust the meter to full scale deflection using the control with the knob. Turn the switch to VSWR position and read the standing wave ratio on the lower scale of the meter.

To read forward power or power being delivered out of the transmitter to the transmission line, turn the switch to forward position and read power directly on M505.

REMOTE CONTROL

All necessary provisions for remote controlling the Gates FM-1B are built into the equipment.

1. Remote plate voltage is obtained from TB503 terminal 8 and is controlled by R521.
2. Remote plate current is obtained from TB503-7 and is controlled by R520.
3. The "LINE ON" function from the fail-safe relay in the remote control unit is connected to TB503-2 and TB503-3.
4. The plate ON function is connected between TB503-5 and TB503-6. Remove the jumper between the TB503-4 and TB503-5 for remote operation. Its function requires a momentary "on" type of function.
5. The plate OFF function is connected between TB503-5 and TB503-4. This function requires a momentary "off" type of function.

6. The remote overload reset function is connected between TB503-9 and TB503-10. This connection is 6 volt DC from a stepper position on the remote control unit.
7. The raise-lower functions are connected to TB1-1 and TB1-3 on the motor driven rheostat (M4703C for remote control of tower output).

In the case of the Gates RDC-10C, one side of the 115 V. primary voltage for the motor of M4703C is connected between TB101-7 on the exciter terminal board in the transmitter and TB1-2 on M4703C. The other side of the 115 V. AC line is connected to the common of the remote control unit which is TB2-27.

MAINTENANCE

Maintenance of the FM-1B should consist of periodic checking of tubes, meter readings, cleaning and visual inspection, lubricating places where required.

The use of air filters materially assists in keeping the transmitter interior clean, however, periodic removal of dust will still be necessary. Since electrostatic seals create dust-catchers, special attention should be paid to these places. Support insulators for the tank elements are probably the worst offenders and must be kept clean and free from all foreign material. Failure to do so may result in arc-over and shattering of the insulators. When inspection of the air filter discloses that it is filled with dust or foreign matter they should be discarded and replaced with a new one. The type of filter used in the FM-1B is a disposable type filter and is obtainable from most any local hardware or appliance store.

Once a month the blower and exhaust fan should be cleaned and checked for proper operations. A few drops of light machine oil should be dropped in the oil holes provided at each end of the blower motor. ~~The exhaust fan has sealed~~ bearings and needs no attention.

Once a month the entire transmitter should be cleaned of dust. In the case of the power amplifier, remove the back cover and the enclosure should be wiped clean of dust. The two protective relays should have the dust cleaned as required and contacts burnished with a burnishing tool. Each relay is protected with a dust cover and are telephone type relays and will require little or no attention.

This transmitter is a precision electrical device and as such, should at all times be kept clean and free from dirt and dust. Dust shortens the life of many components due to flashovers, arcs, etc., which damage the same. A small brush or soft rag can be used very effectively in keeping the equipment clean.

A good preventative maintenance schedule will provide best assurance of trouble-free transmitter operation.

PARTS LIST

TRANSMITTER CABINET

<u>Symbol No.</u>	<u>Drawing No.</u>	<u>Description</u>
B501	430 0002 000	Fan, 115V., 50/60 cy. 1500 RPM, 650 cfm.
C501, C502	510 0246 000	Cap., 4.0 mfd., 5000 V. (W)
F501, F502	398 0186 000	Fuse, 30 amp., 230 V.
L501, L502	476 0105 000	Choke, 10 Hy.
R501	552 0405 000	Rheostat, 15 ohm, 150 W.
R502, R503	540 0618 000	Res., 2000 ohm, 2 W., 5%
R504, R505	552 0721 000	Rheostat, 2 Section in tandem, 300 ohm per section
R506, R507,		
R517	542 0056 000	Res.; 20 ohm, 10W.
R508	542 1051 000	Res., 2.5 ohm, 10 W.
R509	550 0029 000	Control, 10K ohm
R511	548 0004 000	Res., 5 meg. meter multiplier
R513	542 0565 000	Res., 100K ohm, 190W.
R510	550 0067 000	Control, 10K ohm
S509, S511	600 0162 000	Switch, rotary
S510	600 0302 000	Switch, 1 section, 3 circuit, 5 position
S512	600 0280 000	Switch. Rotary
S513	604 0208 000	Switch, Pressure
S514	604 0061 000	Interlock Switch
S516	926 6665 001	Interlock Switch and Grounding Hook Assembly
T301, T302	472 0111 000	Transformer, P.A. Filament
T501	472 0307 000	Transformer, Power
TB501	614 0047 000	Terminal Board, Audio
TB502, TB517	614 0092 000	Terminal Board, 115V., A.C. and FM-10A Jumper
TB506	614 0052 000	Terminal Board, Contactor Panel
TB507	614 0046 000	Terminal Board, Fan
TB510	614 0100 000	Terminal Board, Contactor Panel
TB511	614 0093 000	Terminal Board, Powerstat FM-10A
TB514	614 0046 000	Terminal Board
XF501	402 0015 000	Fuse Block

4/26/61

-1-

FM-1B, M5597

PARTS LIST

METER PANEL

<u>Symbol No.</u>	<u>Drawing No.</u>	<u>Description</u>
M501	630 0049 000	Meter, Fil. Volt 3-1/2" 0-10V. AC (non-magnetic panel)
M502	632 0074 000	Meter, PA Grid Current, 3-1/2" 0-50 MA DC (non-magnetic panel)
M503	632 0026 000	Meter, PA Plate Current, 3-1/2" 0-1 Amp. DC (non-magnetic panel)
M504	632 0148 000	Meter, Plate Voltage, 3-1/2" 0-1 MA DC movement w/0-5000 V. DC Scale (non-magnetic panel)
M505	913 1256 001	Meter, R.F. Output
C503; C504, C505, C506, C507	516 0082 000	Meter By-pass Cap., .01 mfd., 1 KV

POWER AMPLIFIER TANK

B301	432 0026 000	Blower, 115V. 50/60 cycles, CCW
C303; C308 C304, C305, C306, C307	520 0091 000	Cap., Variable, 50 mmfd.
C311	516 0204 000	Cap., 100 mmfd., 5000 V.(W)
C312	520 0249 000	Cap.; Variable, 20 uuf.
C313, C314	516 0233 000	Cap., 500 mmfd., 30 KV. Neut. Padding Condenser (Det. by Freq.)
DC501	620 0034 000	Micro-match, 0-1200 W. 50 ohm
J301	612 0232 000	Receptacle "N"
J302	612 0230 000	Receptacle "UHF"
L301 L302, L303	813 1281 001	Plate Choke
L306	494 0004 000	Choke, 7 Microhy.
L304	813 1532 001	Input Grid Coil
L305	813 1531 001	Input Couplet Coil
L309	926 5524 001	Plate Line Assembly
L310	813 1060 001	Output Coupling Loop
L311	910 9741 001	Monitor Loop Assembly
R301, R304, R305	542 0728 000	Res.; 100 ohm, 2W. 10%
R306	542 0085 000	Res.; 3500 ohm, 10W.
R307	542 0088 000	Res.; 5000 ohm, 10W.
R308, R309	540 0740 000	Res.; 1000 ohm; 2W. 10%
R310	542 0316 000	Res.; 2000 ohm, 20W.
TB301	614 0113 000	Terminal Board
TB302	614 0092 000	Terminal
V301, V302	374 0010 000	Tube, 4-400A
XV301, XV302	404 0055 000	Socket

4/26/61

-2-

FM-1B, M5597

FARTS LIST

CONTROL PANEL

<u>Symbol No.</u>	<u>Drawing No.</u>	<u>Description</u>
A501, A505, A506, A507, A508	396 0105 000	Lamp, 14 V.
A503	396 0062 000	Lamp, Neon
R518, R519	540 0202 000	Res., 100K ohm, 1/2W. 10%
S502, S506	604 0067 000	Switch; Pushbutton; Black
S503, S507	604 0069 000	Switch; Pushbutton; Red
S517	604 0150 000	O.L. Reset Pushbutton Switch
S518, S519	604 0032 000	Toggle Switch, D.P.D.T.
KA501	406 0052 000	Pilot Light Assembly, Green
KA503	406 0051 000	Pilot Light Assembly, Red
KA505, KA506, KA507, KA508	406 0053 000	Pilot Light Assembly, Amber

CONTRACTOR PANEL

CR501, CR502	386 0015 000	Silicon Diode, 10 V.
K501, K503	570 0055 000	Contactor, 4 pole, 25 amp. 230V.
K502	574 0074 000	Relay, 6V. A.C., S.P.D.T.
K505, K506	572 0025 000	Relay, 2-C
K507	574 0014 000	Relay, 6V. D.C., S.P.D.T.
R514	542 0056 000	Res., 20 ohm, 10W.
R515	542 0085 000	Res., 3.5K ohm, 10W.
R516	550 0061 000	Control, 1K ohm, 2W.
R520, R521	550 0057 000	Control, 250 ohm, 2W.
T502	472 0112 000	Transformer, Rect. Fil.
TB503	614 0054 000	Terminal Board
TB504, TB505	614 0104 000	Terminal Board
TB513	614 0034 000	Terminal Board, O.L. Relay Deck
TB515	614 0092 000	Terminal Board
TB516	614 0094 000	Terminal Board
V501, V502	374 0027 000	Tube, 673
XV501, XV502	404 0121 000	Socket

4/26/61

-3-

FM-1B, M5597

PARTS LIST

M-5652A POWER SUPPLY

<u>Symbol No.</u>	<u>Gates Part No.</u>	<u>Description</u>
C201,C202	510 0500 000	Capacitor, 8 mfd., 1000V. D.C.
F201	398 0015 000	Fuse, 1/2 amp., 250 V.
F202	398 0079 000	Fuse, Slo-Blo, 1-1/2 amp. 125V.
L201,L202	476 0017 000	Filter Reactor
R201	542 0163 000	Resistor, 100K ohm, 20W.
T202	472 0090 000	Filament Transformer
TZ03	472 0017 000	Plate Transformer
TB201	614 0076 000	Terminal Board
TS201,TS202	614 0189 000	Tie Point
XF201,XF202	402 0021 000	Fuseholder
XV201	404 0016 000	Socket

600V. SCREEN RECTIFIER BOARD ASSY

C801 thru C820	516 0082 000	Cap., .01 uf 1 KV
CR801 thru CR820	384 0020 000	Silicon Diode 1N 2071
R801,R802	540 0728 000	Res., 100 ohm, 2W. 10%

M-4845 RF OUTPUT EXTENSION KIT

A1	384 0006 000	Diode
C1,C2	516 0054 000	Cap., .001 mfd., 1 KV
J1	612 0230 000	Receptacle, "UHF"
L2	494 0004 000	R.F. Choke, 7 microhy.
	610 0231 000	Plug, UHF
R1	552 0545 000	Control, 1000 ohm
R2	540 0178 000	Res., 1K ohm, 1/2 W., 10%
R3,R4	540 0728 000	Res., 100 ohm, 2 W., 10%
TB1	614 0069 000	Terminal Board

4/26/61

-4-

FM-1B, M5597

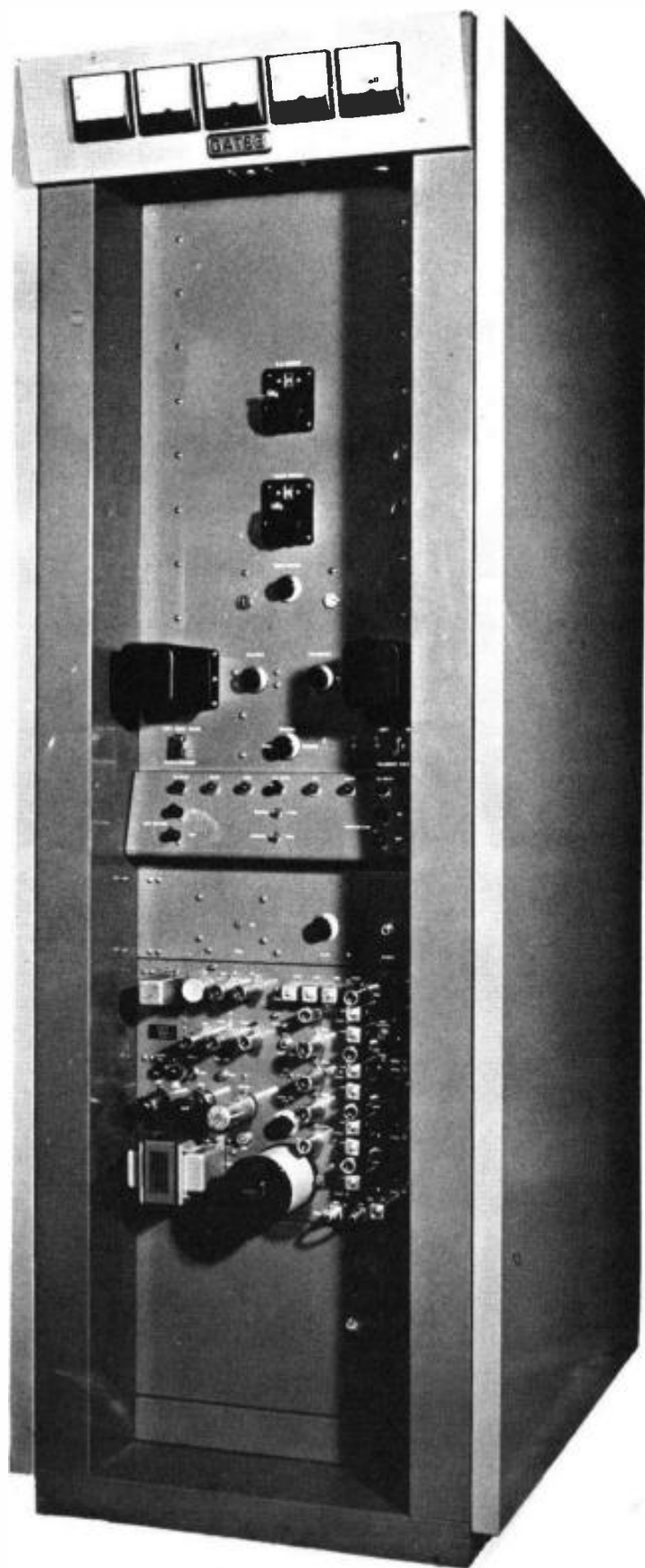

800 0291 003

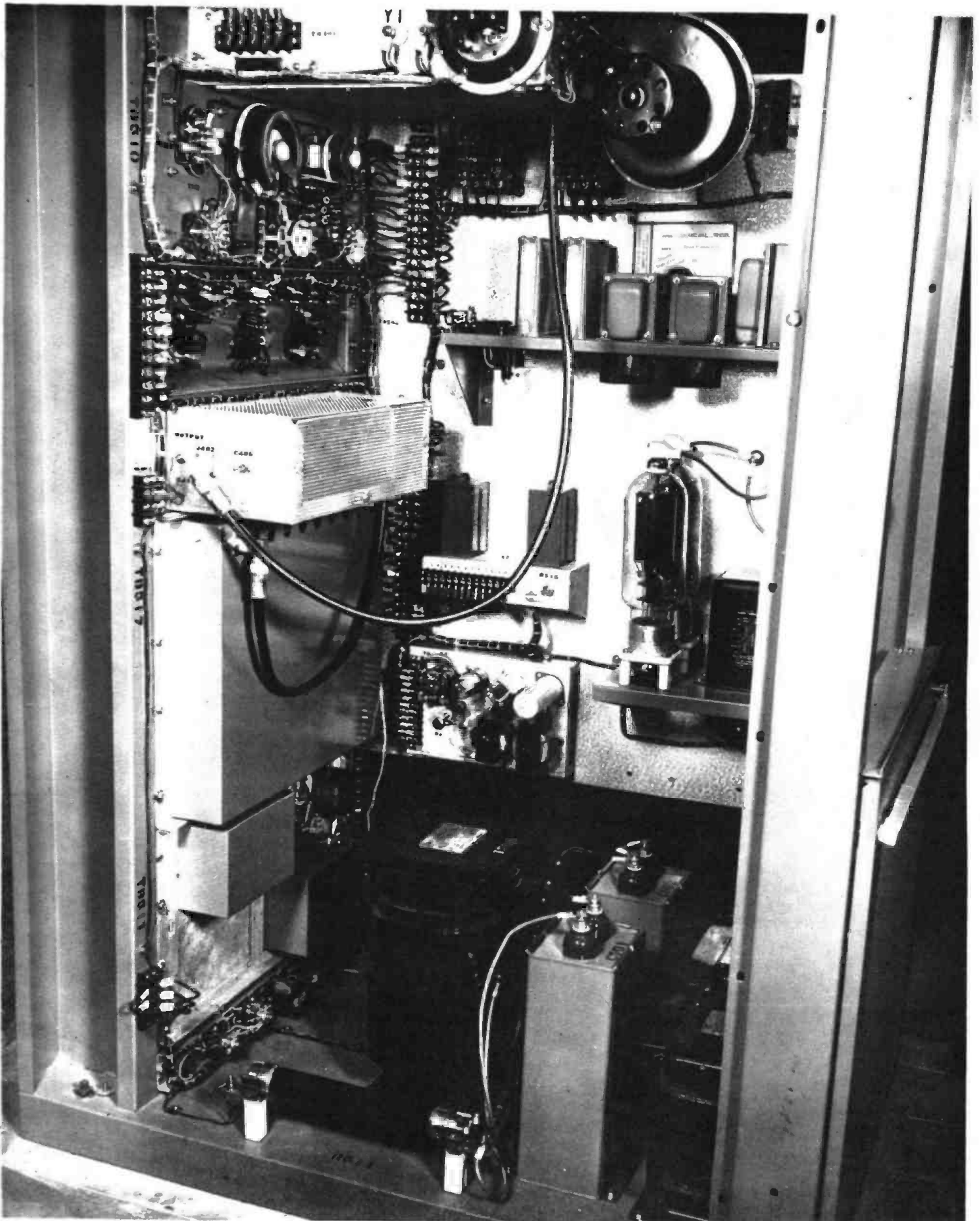

800 0292 003

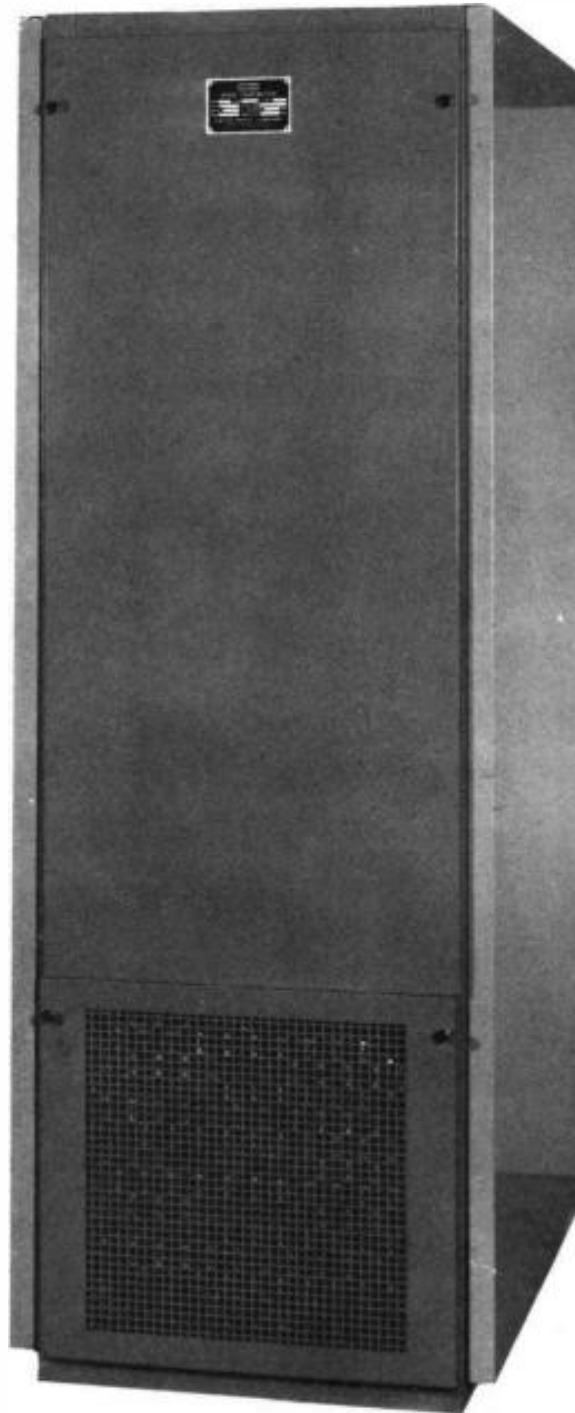

DO-166

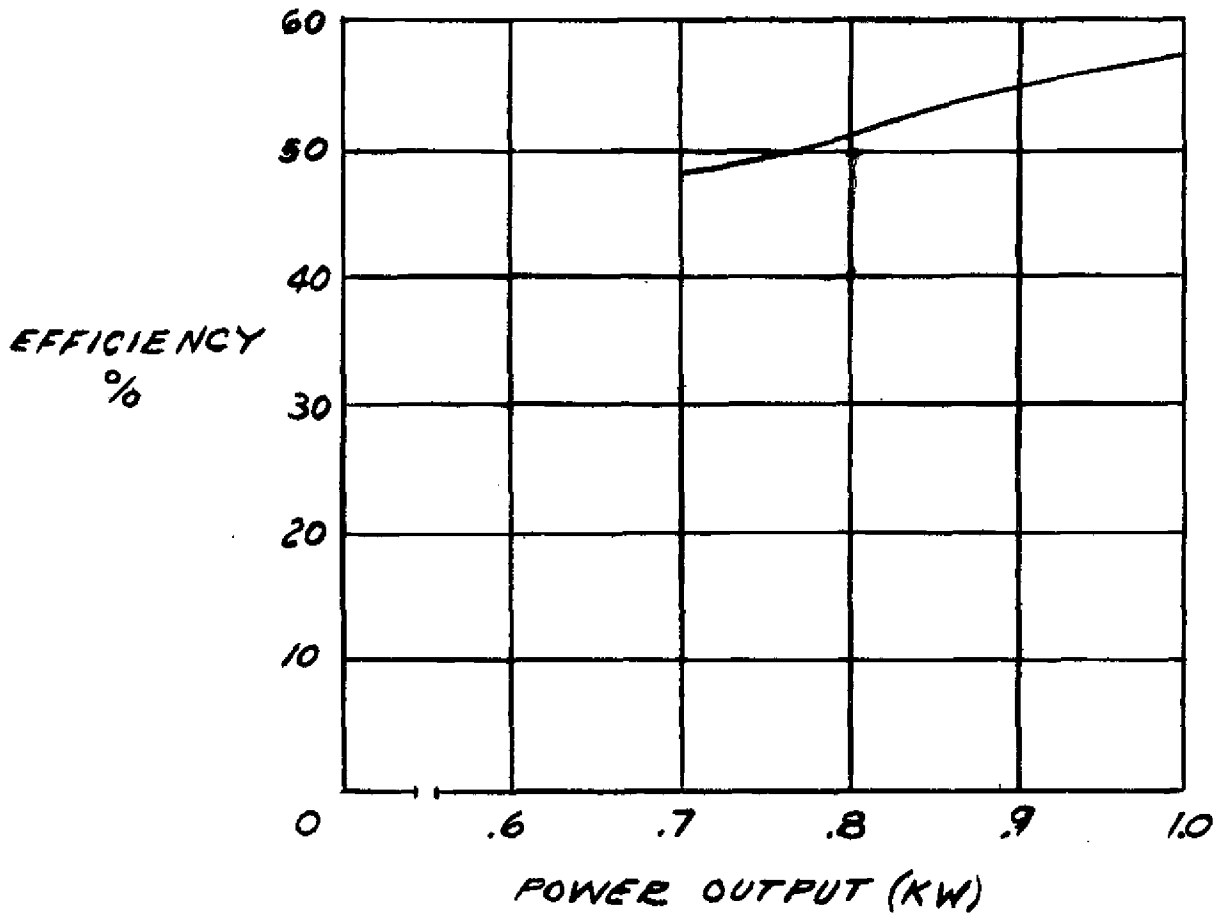

#1860 Reducer
from 1-5/8 to
7/8

2nd Harmonic Filter

If 7/8" line is
used, customer will
require #1860 Reducer
(1-5/8 to 7/8") #75R
fitting and #18275
inner connector.

If 1-5/8" line is
used, go directly to
#77E with inner con-
nector or thru
#1261B gas barrier.

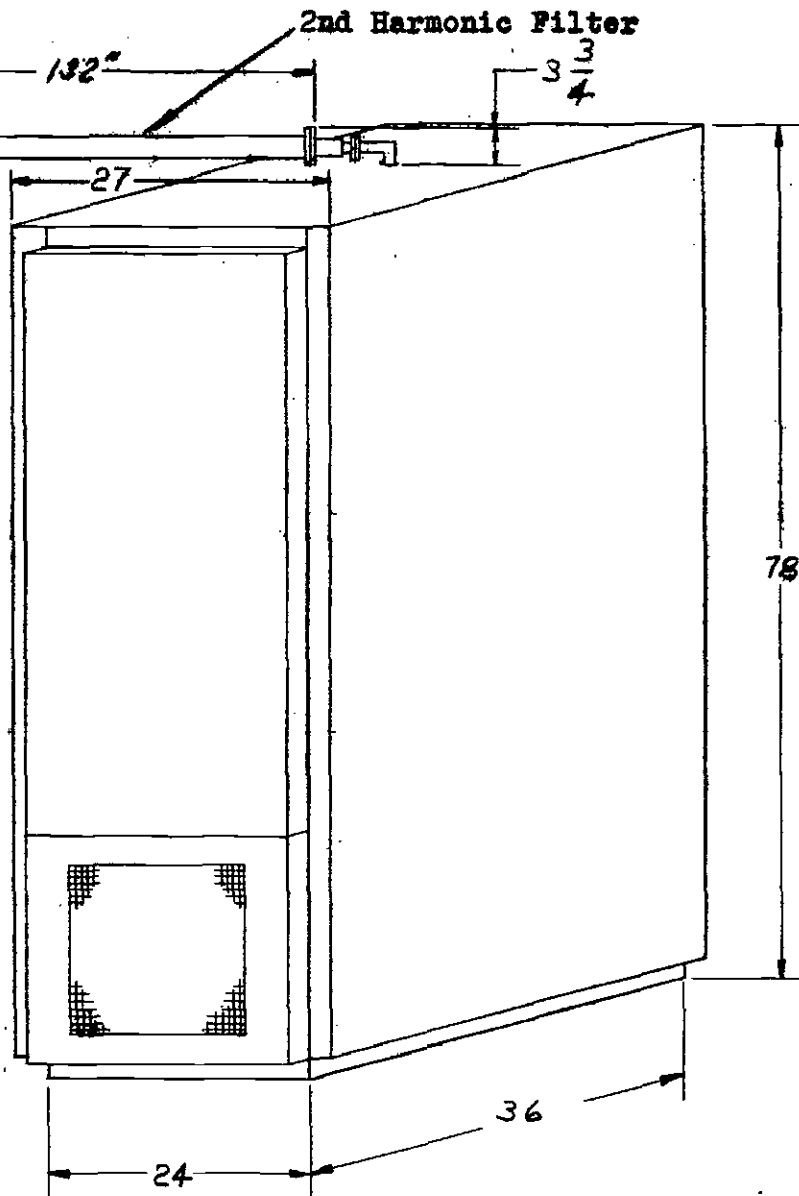

FM-1B

TB503

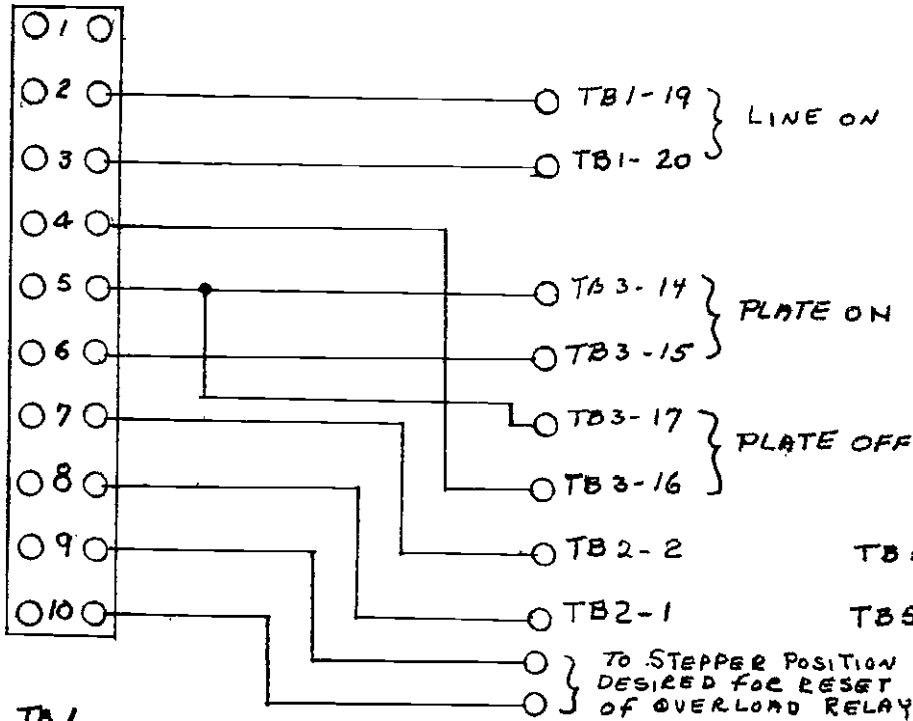

TB1

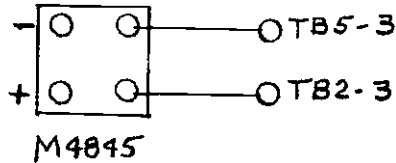
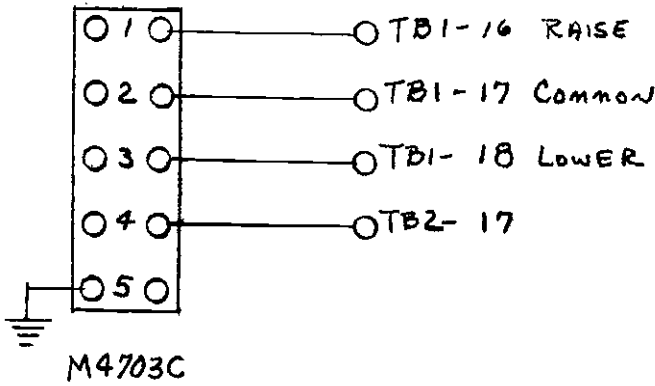

1.

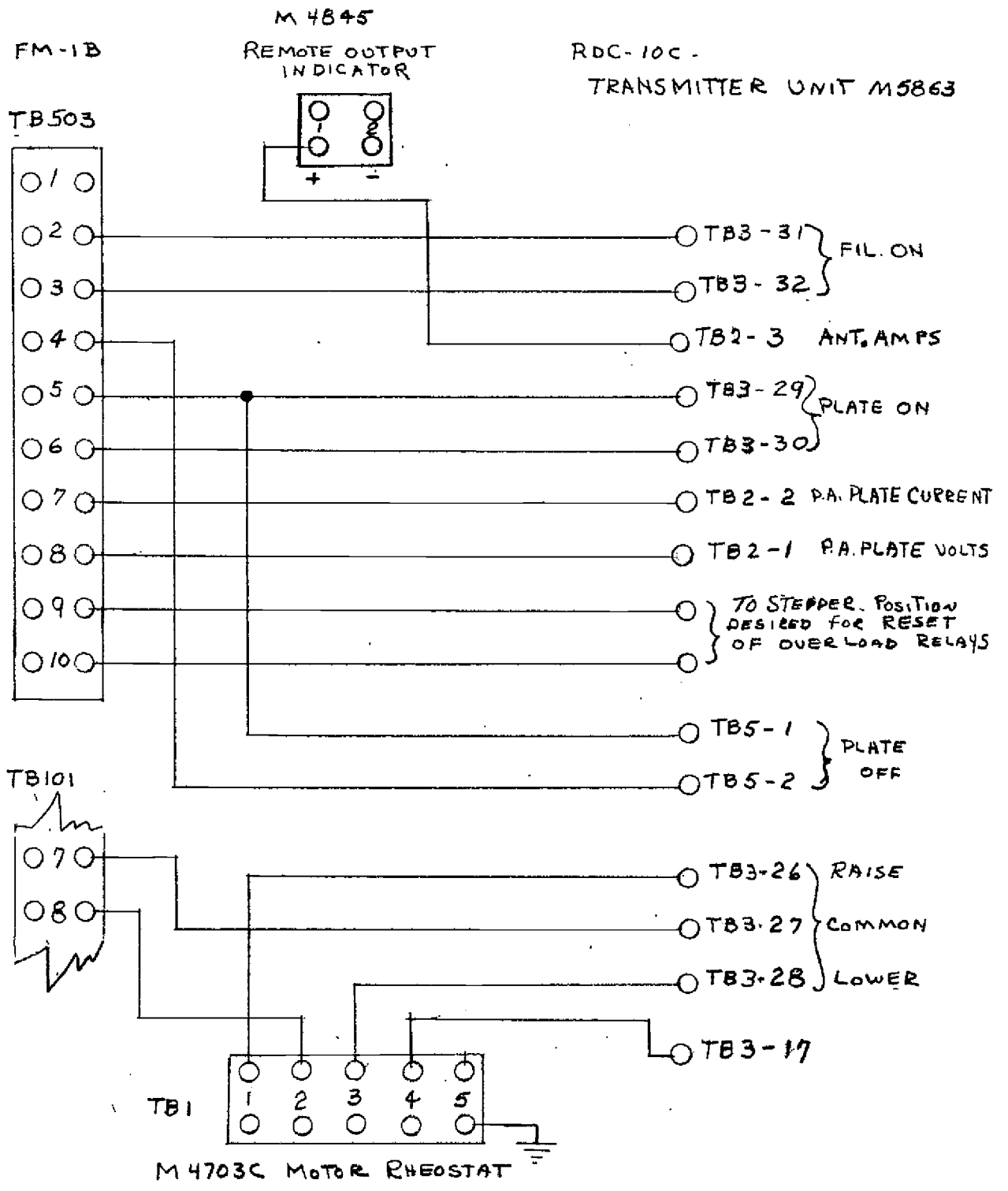

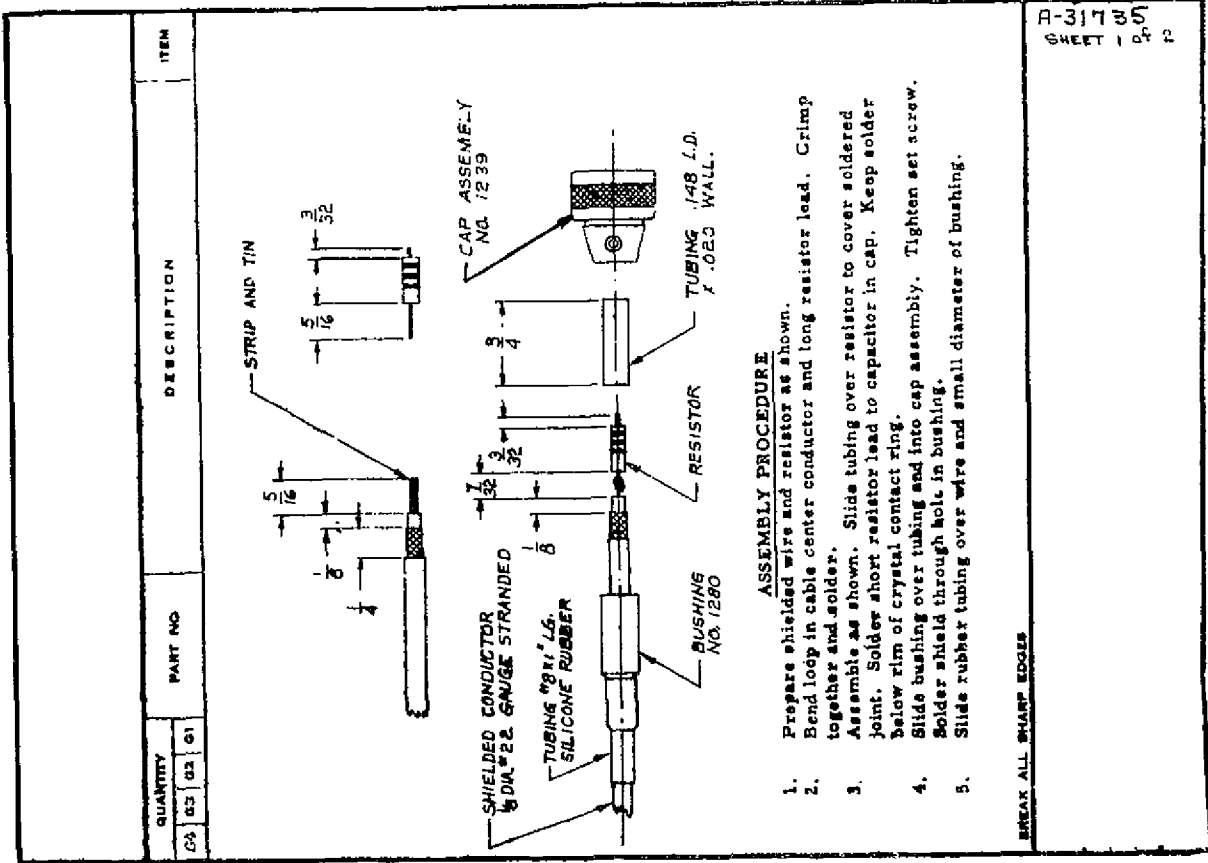

A-31735
SHEET 1 of 2

A-31735
SHEET 1 of 2

A-31735
SHEET 2 of 2

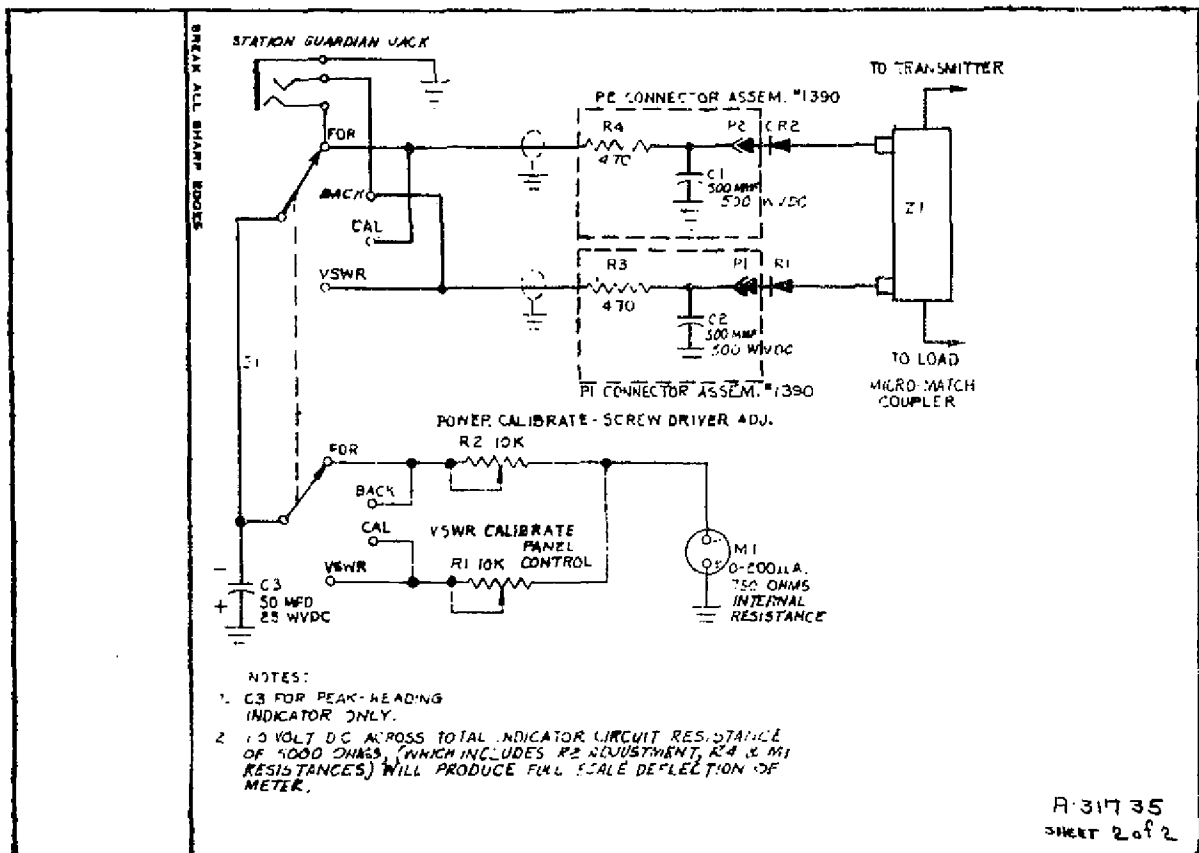

A-31735
SHEET 2 of 2

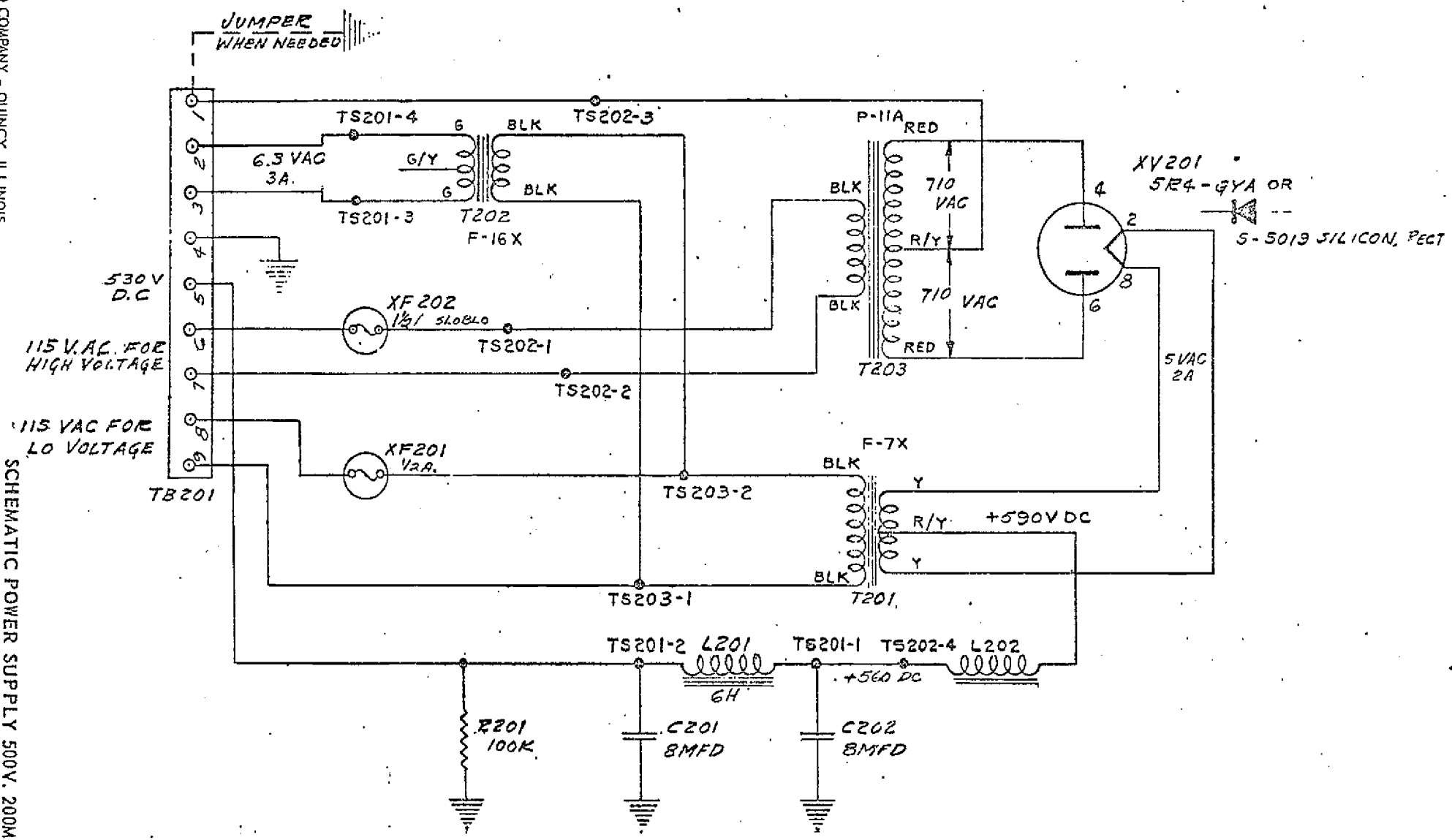

GATES RADIO COMPANY - QUINCY, ILLINOIS
A DIVISION OF HARRIS-INTERTYPE CORPORATION

SCHEMATIC RECYCLE UNIT FM TRANSMITTERS M-6023
826 7314 001

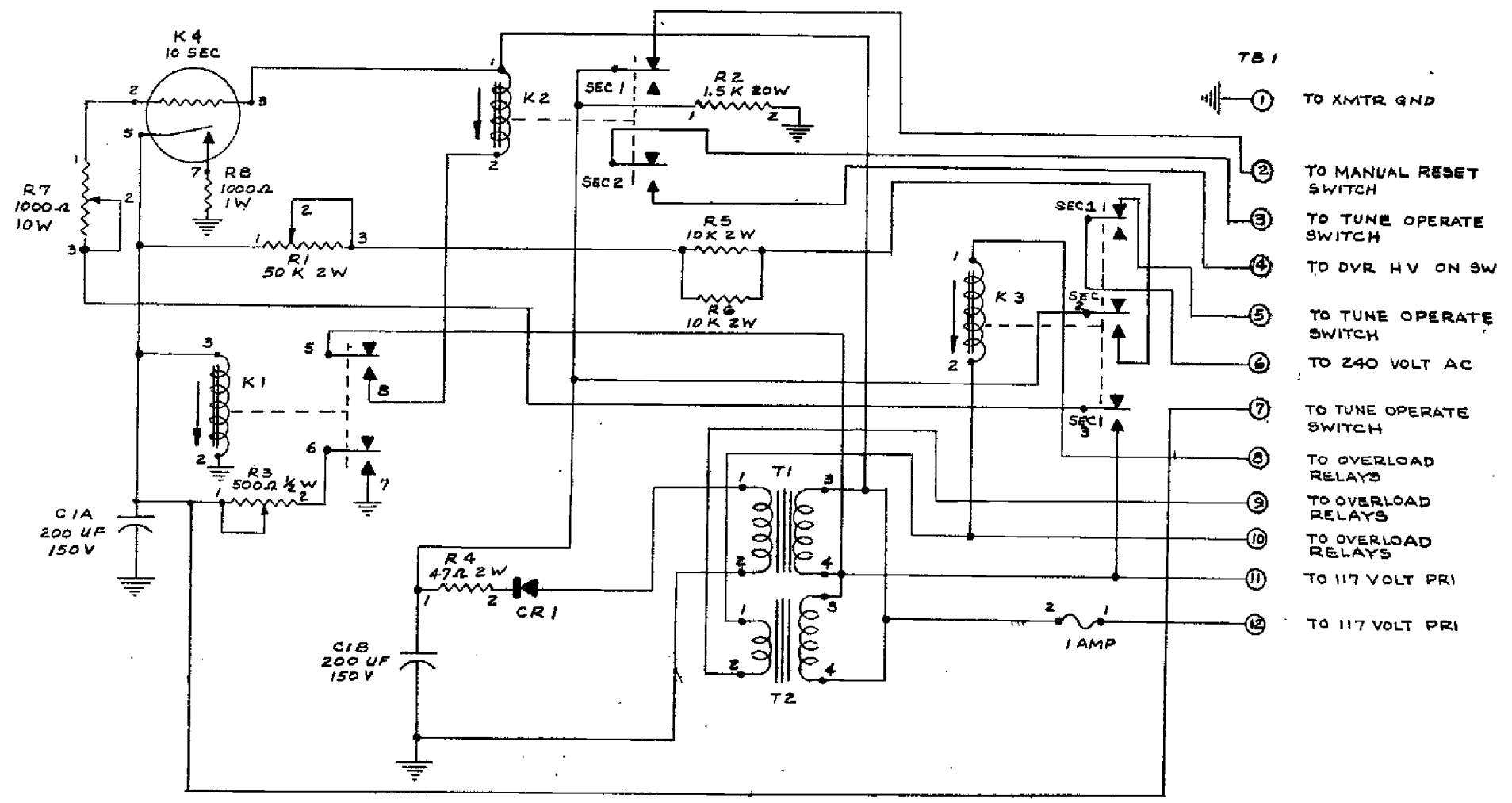

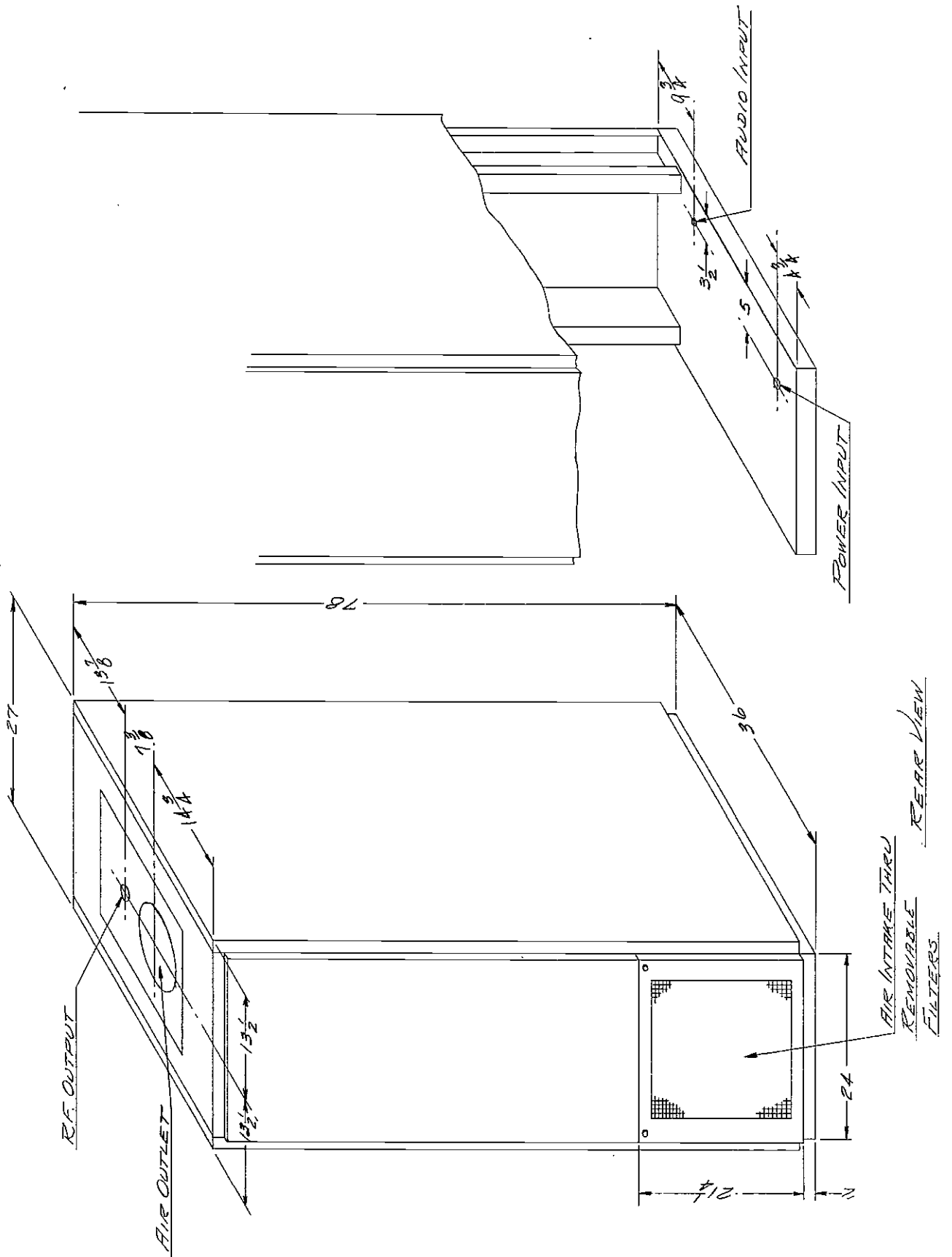

5519 TUNE OPERATE SW.
5518 LOCAL - REMOTE SW.
5517 Q.L. RESET

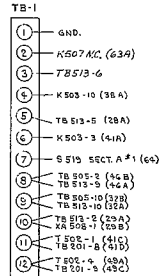
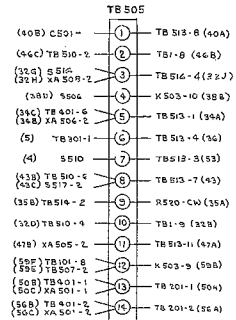
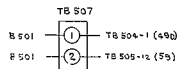
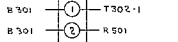
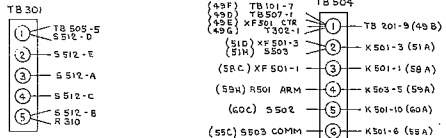
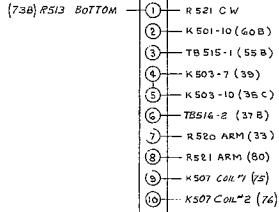
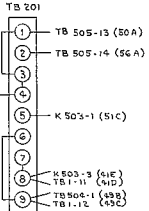
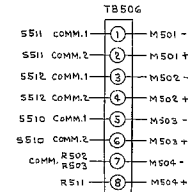
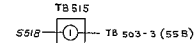
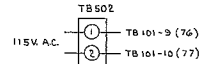
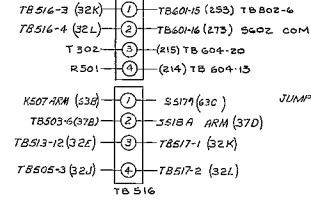
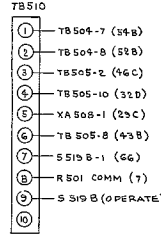
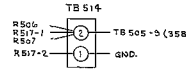
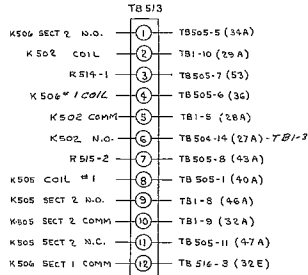
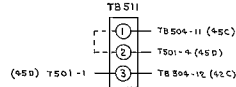
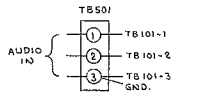
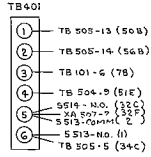
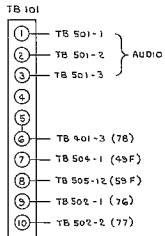

*R407 & R408 ARE USED IN FM-1B ONLY

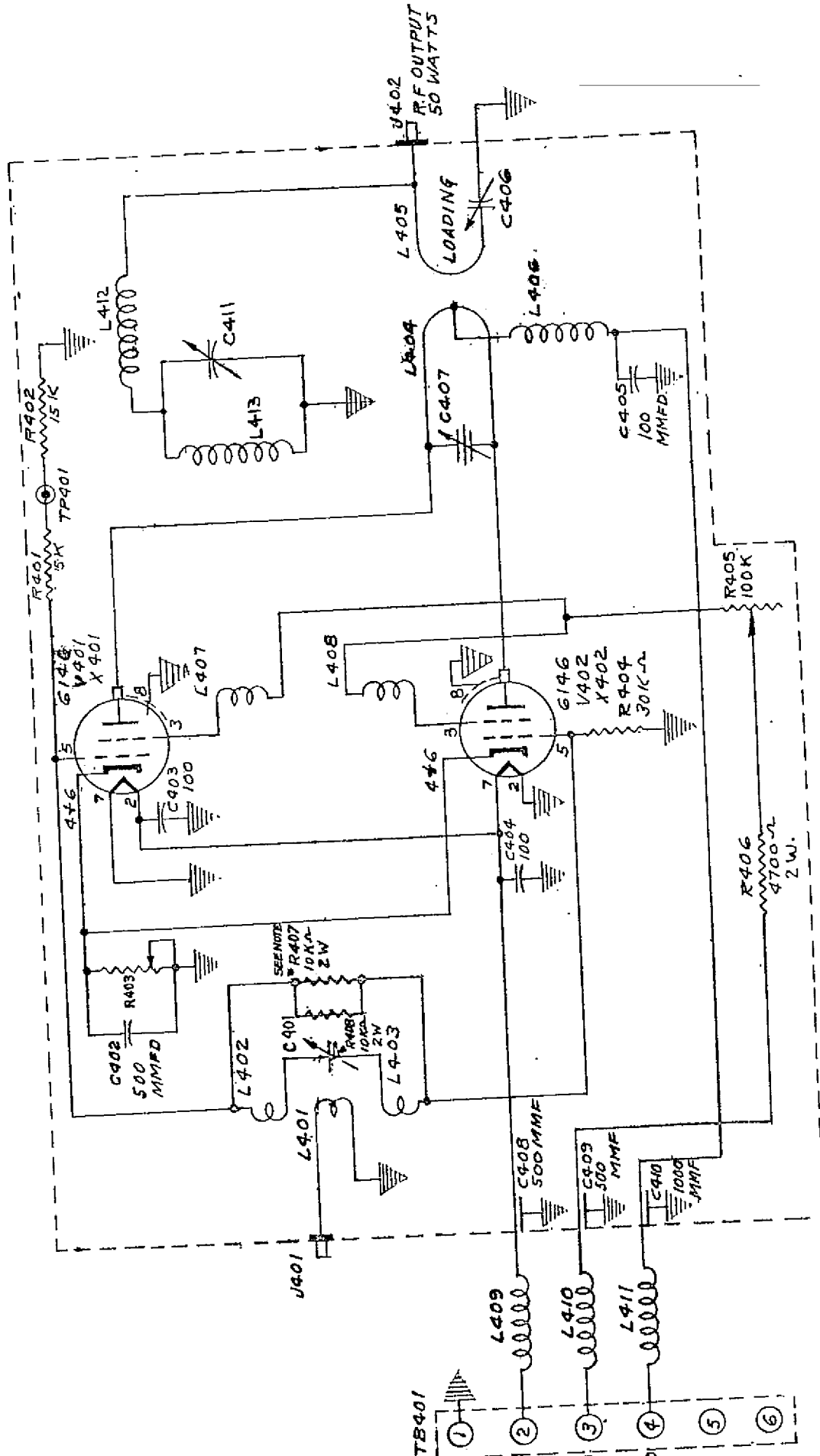

SCHEMATIC, 50 WATT AMPLIFIER, M5675 FOR BFE-50B, BFE-50C

INSTRUCTIONS FOR OPERATION OF M5675 AMPLIFIER

General Description

The M5675 Amplifier covers a frequency range of 88 to 108 mc. This is done without the addition or removal of any padding components in either grid or plate circuits. Power gain of this amplifier is approximately 10. When used as a final output stage, maximum power output is in the vicinity of 50 to 60 watts. The M5675 may also be used to drive following amplifier stages.

The series type of circuit is used in the grid and a conventional parallel type of circuit is used in the plate. This tends to make for less susceptibility of parasitics at higher frequencies than the amplifier is used. Screens of the 6L46 amplifier tubes are isolated by chokes rather than RF grounded. This has proven to be more effective at VHF frequencies and eliminates the need for neutralizing. The reader should refer to schematic B-65555 for a better understanding of the circuit.

Tune-up

This particular amplifier should be tuned up for best efficiency and coupled for best transfer of power even if considerably less than full output power is desired. The screen control may then be turned down to reduce output power to the desired level.

To tune the grid circuit, place the negative probe of a voltmeter, into TP401 and ground the positive lead. With drive connected to input receptacle J401, tune C401 (grid tuning) for maximum negative reading on the voltmeter. This voltage may vary all the way from -15 to -45 volts depending on the amount of drive. This reading will drop as soon as screen and plate voltage are applied to the amplifier.

After the grid circuit has been properly tuned, coupling between L401 and L402, L403 should be varied to obtain the maximum negative voltage at TP401 with a minimum of drive. C401 must be retuned each time coupling is changed.

When the input circuit has been properly tuned, plate and screen voltage may be applied to the amplifier and the plate circuit tuned. It is recommended that this be done with the amplifier coupled into a 51 ohm non-reactive load. If plate current is being metered, tune the plate tune control C407 for a dip. Otherwise, tune C407 for maximum power output. Now vary coupling between L404 and L405. Turn amplifier back on and tune C406 for maximum power output along with C407. Several tries may be needed to find the best point of coupling between L404 and L405. Each time the coupling between L404 and L405 is varied, the plate must be retuned along with output coupling capacitor C406.

After tuning has been completed for best power output and efficiency, screen control R405 should be set for the desired power output. In no case should the output circuit be decoupled to reduce output power.

It should be emphasized that this amplifier is easily over-driven. For 50 watts output power approximately 3 watts drive is required. For 15 to 25 watts output power, about 1 watt of driving power is required. If driving power is increased above the required amount, power output of the amplifier will fall off due to high grid leak bias being created. A typical set of readings are given on this amplifier on the following page.

Coupling Amplifier to Another Stage

When the amplifier is going to be used to drive another amplifier stage, it is suggested that it first be tuned up into a load and then coupled to the grid circuit of the following amplifier stage.

To reduce the possibility of oscillations and/or parasitics, the input circuit of the following stage should be properly coupled and matched to the 51 ohm coaxial line connected to the output of the 50 watt amplifier. This may be done with a micromatch coupling unit. The following grid and input circuit should be adjusted for minimum SWR.

If a micromatch coupling unit is not available, the input coupling and grid tuning of the following stage should be tuned for maximum grid current in that stage.

If the following input circuit is properly matched, plate tuning of the 50 watt amplifier will not change appreciably when switching from a non-reactive load to being coupled to the following amplifier stage.

If the 50 watt amplifier stage was properly tuned up into a load and plate tuning deviates radically from where it was after being coupled into another stage, a major mis-match exists.

If the 50 watt amplifier unit is over-driving the following amplifier, screen control R405 should be adjusted for the desired drive. Do not decouple the 50 watt amplifier stage.

TYPICAL OPERATIONAL TEST DATA
OBTAINED ON

M5675 AMPLIFIER OPERATING AT 99.1 MC

Power Out	65 W.	50 W.	23 W.	17 W.	13 W.
Plt. Current	250 Ma.	215 Ma.	140 Ma.	130 Ma.	110 Ma.
Plt. Voltage	500 Volts	520 Volts	570 Volts	580 Volts	590 Volts
Screen Volts	290 Volts	235 Volts	150 Volts	147 Volts	132 Volts
Screen Current	12 Ma.	8.5 Ma.	3 Ma.	2.2 Ma.	1.5 Ma.
Cathode Volts	68 Volts	58 Volts	35 Volts	33 Volts	29 Volts
Driving Power	6.5 Watts	2.5 Watts	1 Watt	.8 Watt	.8 Watt
Grid Voltage	-10/-42"	-7/-33"	-8.5/-23"	-6.5/-20"	-3.5/-15"
(Grid voltage measured at TP401.		indicates voltage before applying screen and plate voltage)			
Plt. Pwr. Input	107 Watts	97 Watts	75 Watts	72 Watts	61 Watts
Plt. Dissipation	42 Watts	47 Watts	52 Watts	55 Watts	48 Watts
Plt. Circuit Efficiency	61%	52%	31%	23.5%	21%

Figures below obtained with no drive.

Plt. Voltage	550 Volts	560 Volts	580 Volts	580 Volts	590 Volts
Plt. Current	165 Ma.	155 Ma.	125 Ma.	125 Ma.	105 Ma.
Cathode Volts	45 Volts	40 Volts	31 Volts	31 Volts	27 Volts
Plt. Dissipation	83 Watts	80 Watts	69 Watts	69 Watts	59 Watts

(All readings were made with screen connected to regulated +320 regulated supply)

PARTS LIST

<u>Symbol No.</u>	<u>Gates Stock No.</u>	<u>Description</u>
C401	520 0004 000	Cap., Variable, 2-19 mmfd.
C402	502 0194 000	Cap., 500 mmfd., 500V. Button Type
C403, C404, C405	516 0215 000	Cap., 100 mmfd, +10%
C406	520 0115 000	Cap., Variable, 5-25 mmfd.
C407	520 0164 000	Cap., Variable, 2-15 mmfd.
C408, C409	516 0227 000	Feedthru Cap., 500 mmfd.
C410	516 0235 000	Feedthru Cap., 1000 mmfd.
C411	520 0112 000	Var. Cap., 2.2-21.5 mmfd.
J401, J402	612 0233 000	Receptacle
L401	813 1772 001	Grid Coupling Coil
L402	813 1762 001	Grid Coil
L403	813 1761 001	Grid Coil
L404	913 1774 001	Plate Coil Assembly
L405	813 1771 001	Plate Output Loop
L406	494 0007 000	R. F. Choke
L407, L408, L410, L411	494 0004 000	R. F. Choke
L409	813 0246 001	Filament Choke
L412	813 3607 001	Coil
L413	813 3608 001	Coil
P401, P402	620 0122 000	Right Angle Adaptor, UG-27C/U
R401, R402	540 0482 000	Res., 15K ohm, 1W. 10%
R403	552 0058 000	Res., 500 ohm, 25W. Adj.
R404	540 0367 000	Res., 30K ohm, 1W., 5%
R405	550 0073 000	Control, 100K ohm
R406	540 0748 000	Res., 4700 ohm, 2W., 10%
R407, R408	540 0752 000	Res., 10K ohm, 2W., 10%(Used in FM-1B/1C only)
TB401	614 0096 000	Terminal Board
TP401	614 0312 000	Test Point Jack
V401, V402	374 0051 000	Tube, 6146
XV401, XV402	404 0016 000	Socket, Octal

*R407 & R408 ARE USED IN FM-1B ONLY

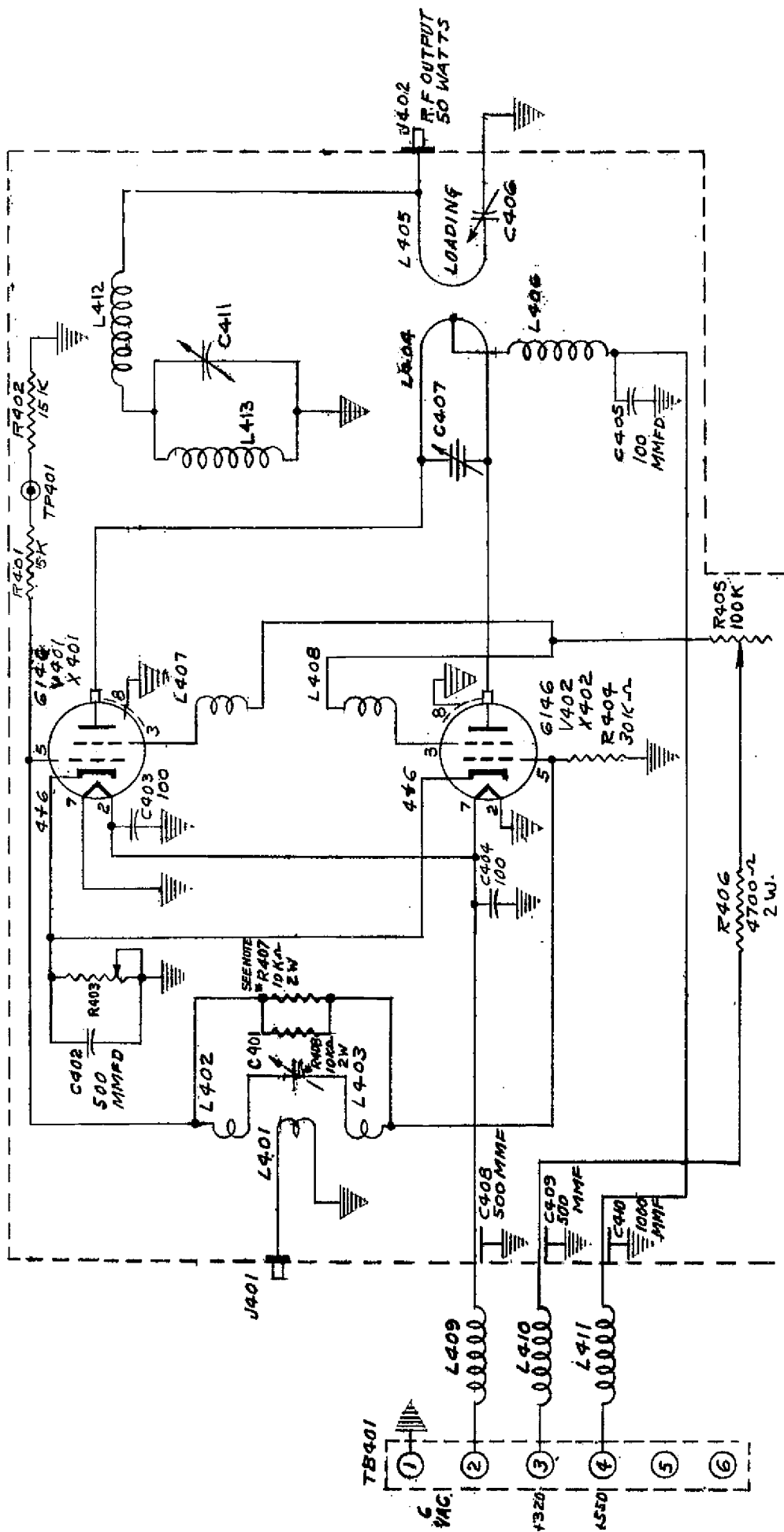

SCHEMATIC, 50 WATT AMPLIFIER, M5675
FOR BFE-50B, BFE-50C

SPECIFICATIONS

The FM Harmonic Filter is of a distributed constant nature using coaxially designed elements.

The characteristic impedance of the filter is 50 ohms, therefore, matching both the output impedance of the transmitter and the transmission line to be used.

The insertion loss of the filter is 0.2 db or less at the operating frequency resulting in low power loss in the filter.

With the aid of the filter all transmitter harmonics are suppressed at least 70 db below the fundamental.

Since the filter is of a symmetrical design either end can be used as an input.

The filter proper is an 11 foot section of 1-5/8" dia. coaxial line provided with 1-5/8" fixed flanges at each end. Included with the filter is one adaptor for reduction to a 7/8" coaxial line on one end. A 7/8" right angle bend is also provided to aid in a flexible installation.

INSTALLATION

Since the filter is not a standard section of transmission line, special care should be taken when installing the filter to prevent damage to the inner conductor.

If the 1-5/8" to 7/8" coaxial adaptor is used this problem is reduced because the inner conductor is captive. When using the 1-5/8" coaxial line directly, it is suggested that the inner conductor of the filter be slipped out several inches and mated with the inner conductor of the transmission line. If the filter is mounted vertically it is very important that the transmission line sections above the filter be installed properly so as not to have the added weight of the inner conductors bearing down upon the inner conductor of the filter.

							FIRST MADE FOR	GATES RADIO COMPANY QUINCY, ILLINOIS			B-65672	
108	109	104	103	102	101	DR. NO.	LIST OF PARTS					SCALE
QTY.	QTY.	QTY.	QTY.	QTY.	QTY.	ITEM	REFERENCE	PT. OR G.N.	FIN.	DESCRIPTION	MATERIAL	

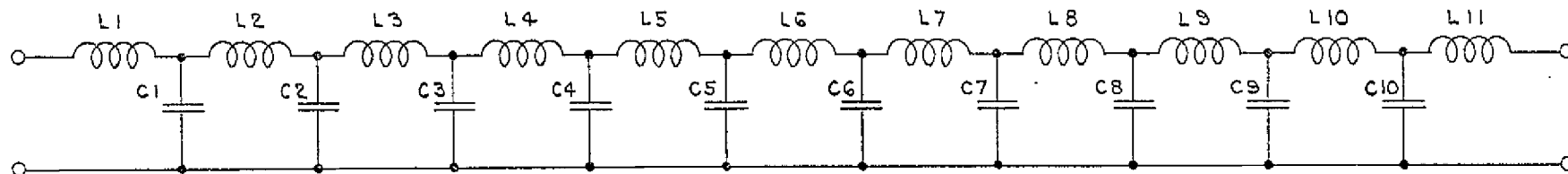
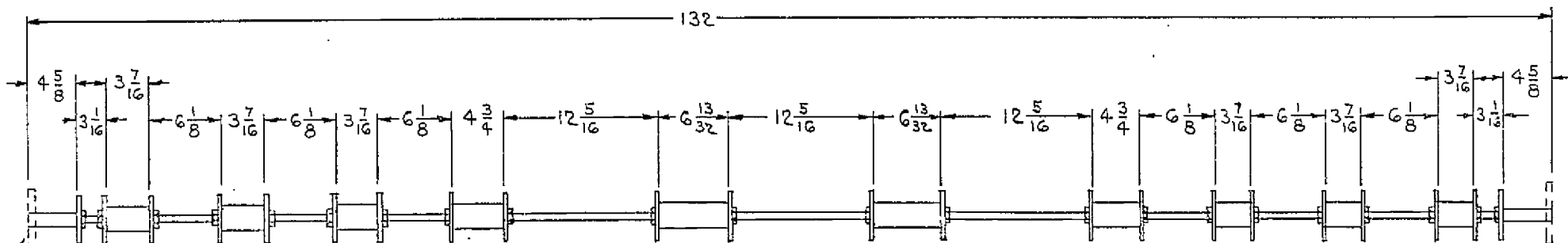

LOW FREQ. EQUIVALENT CIRCUIT

50. Ω INPUT

$f_c = 165$ MC

INSERTION LOSS = 0.2 db OR LESS

LENGTH = FILTER WITH END FLANGES = 11'

FILTER PLUS END FLANGES & ADAPTOR = 12' 6"

MATES WITH 7/8" ANDREW #560 COAX

ECN 7861 JUN 65-59	TITLE COAXIAL LOW PASS FILTER INFORMATION M5737			UNLESS OTHERWISE SPECIFIED, ALL TOLERANCES PER DATUM SPEC 031012	
	MTL		FIN.		SHEET OF B-65672
	DR. BY <i>ZSA</i> DATE 7-2-58	CH. BY	ENG. <i>J E</i>		

PROCEDURE

BOTTOM NUTS ON INNER CONDUCTING ROD.
 ITEMS 7, 8 & 9 INSTALL BEADS ITEM 6 ON
 ROD AND INSTALL ITEMS AS SHOWN BELOW.
 BOTTOM ALL ROD BEFORE TIGHTENING STOP
 NUT, ITEM 11. MAKE CERTAIN ALL CONNECTIONS
 ARE TIGHT, THEN INSTALL ASSEMBLY INTO
 ITEM 10.
 USING APPROPRIATE HARDWARE AT EACH ITEM
 12 TO ONE END & ITEMS 12 & 13 TO THE OTHER
 END OF ITEM 10.

INSTALL ITEM 7 WITH
 ELASTIC END TOWARD
 CONDUCTOR AS SHOWN

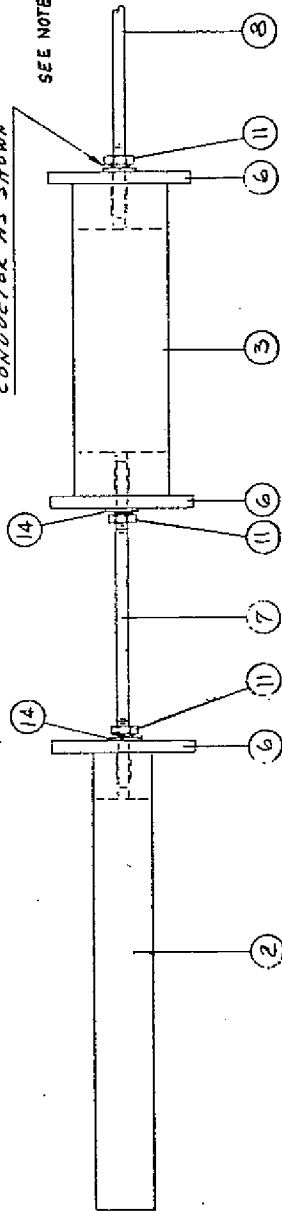

SEE NOTE

NOTE - ITEM 16 TAPE, WRAP SEVERAL TURNS
 EACH SIDE OF BEADS AS SHOWN TO
 PREVENT LINEAR MOVEMENT

ITEMS 5 & 15, LENGTH IS DETERMINED
 BY FREQUENCY SEE DWG A-31690

GROUP 102, 50 OHMS WITH ADAPTER FOR

3/8" COAX

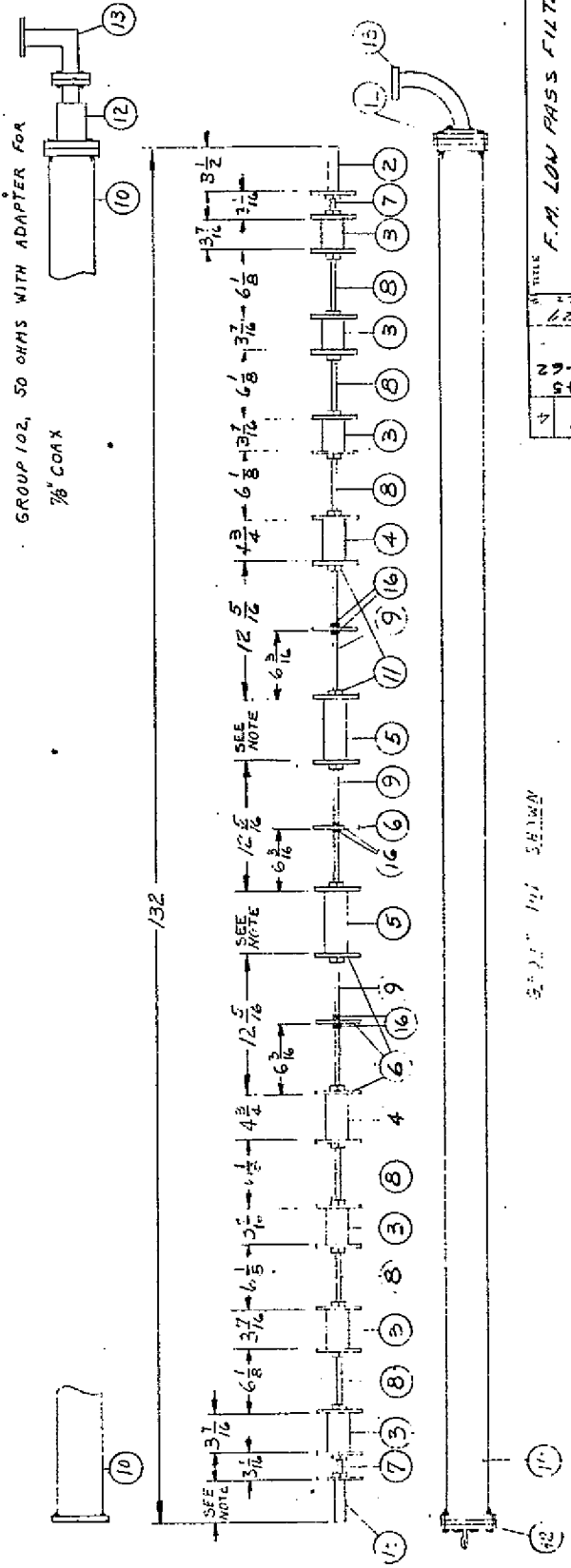

QTY	INT	EXT	QTY	ITEM	REFERENCE	REMARKS	MATERIAL	DESCRIPTION
X	X		1	THIS DWG				ASSEMBLY
1			2	913-1524-003			GA50	ASSEMBLED COAX ADAPTER
6	6		3	913-1523-001			GA50	ASSEMBLED INNER CONDUCTOR
2	2		4	913-1523-002			GA50	ASSEMBLED INNER CONDUCTOR
2	2		5	913-1523-003			GA50	ASSEMBLED INNER CONDUCTOR
25	25		6	813-1522-001			GA50	BEAD
2	2		7	813-7705-001			GA50	INNER CONDUCTING ROD
6	6		8	813-7705-002			GA50	INNER CONDUCTING ROD
3	3		9	813-7705-003			GA50	INNER CONDUCTING ROD
1	1		10	926-5673-002			GA50	ASSEMBLED OUTER CONDUCTOR
22	22		11	304-0057-000				6-32 HEX HD ELASTIC STOP NUT BRASS
2	2		12	620-0089-000				REDUCING ADAPTER
1	1		13	620-0054-000				RIGHT ANGLE BEND (ANDREW #12693)
22	22		14	308-0005-000			GA03	#6 FLAT WASHERS BRASS
1	1		15	913-1524-004			GA50	7/8" WIDE SCOTCH TAPE
X	X		16	299-0006-000			GA50	ASSEMBLED COAX ADAPTER
1	1		17	913-1524-003			GA50	ASSEMBLED COAX ADAPTER
1	1		18	926-5673-002			GA50	ASSEMBLED OUTER CONDUCTOR
1	1		19	620-0089-000				REDUCING ADAPTER #1860 ANDREW
1	1		20	620-0054-000				RIGHT ANGLE ELBOW, 1000M ANDREW
1	1		21	913-1524-004				ASSEMBLED COAX ADAPTER

5-21-47 101 541120

F.M. LOW PASS FILTER

M5737

678163

M-6023 AUTOMATIC RECYCLE UNIT

THEORY OF OPERATION

General

The unit is designed to provide a low voltage source for pilot lights and interlock circuits. In addition, with the transmitter wired properly, it provides a lock-in function on overloads for maximum indication of source of trouble. This lock-in feature can be reset manually at the transmitter or at a remote point.

The third function of the unit makes recycling possible when an overload occurs and the "tune-operate" switch is switched to "operate" position. An R/C circuit operating an auxiliary relay provides three complete recycles during a 10 second interval.

NOTE: The above number of recycles can be changed by adjusting a potentiometer to almost any desired number within a certain time period. Also, the total recycle time can be changed by inserting another time delay relay of the desired type. When using a 10 second time delay and the transmitter has overloaded, the following will occur. If, during the 10 second interval, the transmitter overload has not corrected itself, the transmitter overload at fault will lock out and remain locked out until manually reset. If the transmitter experiences one or two overloads and then clears itself, the recycle unit will again be ready for three more complete recycles after approximately 15 seconds.

Circuit Description

The time constant which determines the pulse interval for recycling is the 50K, 2W. potentiometer, R1, and the capacity of C1A. When the voltage on the positive terminal of C1A equals the voltage necessary to close the relay K1, this occurs, causing the capacitor to discharge through R3, 100 ohm to ground. The discharge time constant is chosen to allow sufficient time for the high voltage contactor to close prior to the reopening of relay K1.

This discharge interval must not be sufficiently long to allow damage to the transmitter in an overloaded condition.

The second set of contacts on relay K2, a slave relay, switches the heavier currents involved in closing the high voltage contactor and also breaking the 130 volts D.C. which locks in the overload relays. Therefore, recycling of the reset occurs just prior to the closing of the high voltage contactor.

The time delay relay, K4, is activated the instant that K3 energizes which occurs when an overload relay locks down. After an elapsed time of ten seconds or three recycle periods, K4 closes, shorting the coil of K1 to ground, thus, stopping the operation of the time constant circuit. After this elapsed time of ten seconds, the unit must be reset either remotely or by the reset button located on the front panel of the 1 KW driver. It is necessary to wait approximately 15 seconds for the element in K4 to cool before you can expect another three recycles.

Relay K3 performs three functions, the aforementioned closing of K2 when K3 is energized, and also to supply 130 V. DC to potentiometer R1 in an overload condition. It also breaks the 230 V. AC which supplies the high voltage contactor coil. In an unenergized condition, K3 breaks 130 V. DC to K1 through R1 and maintains coil voltage to the high voltage contactor. Also, the time delay relay K4 has operating voltage removed which should increase the operating life of this relay. K3 is operated by 6 V. AC which is supplied by the unit. One coil terminal is tied common to the 6 V. AC transformer and the other coil terminal is tied in series with a parallel string of overload relay contacts which return to the other side of the 6 V. AC transformer.

Resistor R4 acts as a surge resistor while R2 is merely a bleeder resistor.

The two switches and one push button which control the recycle unit are mounted on the 1 KW driver control panel. The operation of the push button acts as a manual reset. It is a normally closed switch, which when open, removes 130 V. DC from the 3.5K resistors in series with the coil and overload potentiometers of the overload relays. These relays then open to again permit operation of the transmitter.

The "local-remote" switch opens the circuit for the remote "on" function, thus placing the transmitter in a local operate condition only.

The "tune-operate" switch performs two functions, in "tune" position it shorts out the coil of K1 in the recycle unit, thus making the unit inoperative. In "operate position", the short is removed from the coil of relay K1. When the 1 KW transmitter is used as a driver for a higher power amplifier, the "tune-operate" switch also performs the following functions. It supplies 240 V. AC to the manual push button on the P.A. high voltage control panel when in "tune" position. In this position the driver and P.A. high voltages must be turned on independently. In "operate" position the short is removed from the coil of K1 and the 240 V. AC is removed from the P.A. high voltage push button on the P.A. Instead 240 V. AC is supplied to one contact of the K809 under-drive auxiliary relay, which when closed, turns the P.A. high voltage contactor on.

PARTS LIST

M-6023 A AUTOMATIC RECYCLING UNIT

<u>Symbol No.</u>	<u>Gates Part No.</u>	<u>Description</u>
C1	524 0091 000	Cap., 200-200 mfd. 150 V.
CR1	384 0020 000	Silicon Rectifier
F1	398 0017 000	Fuse, 1 amp. 250 V.
K1	574 0020 000	Plug-in Relay, Double Pole
K2	574 0040 000	Relay, 115 V. AC, DPDT
K3	574 0105 000	Relay, 6V. AC, 3PDT
K4	576 0019 000	Time Delay Relay, 115V. 10 Second
R1	550 0071 000	Control, 50K ohm, 2W.
R2	542 0135 000	Res., 1.5K ohm, 20W.
R3	550 0059 000	Control, 500 ohm, 2W.
R4	540 0724 000	Res., 47 ohm, 2W. 10%
R5, R6	540 0752 000	Res., 10K ohm, 2W. 10%
R7	552 0023 000	Adj. Res., 1000 ohm, 10 W.
R8	540 0468 000	Res., 1000 ohm, 1 W. 10%
T1	472 0208 000	Isolation Transformer
T2	472 0090 000	Fil. Transformer
TB1	614 0034 000	Terminal Board
XF1	402 0021 000	Fuseholder
XK1, XK4	404 0016 000	Octal Socket

1/29/61

- 1 -

M6023
Automatic Recycle Unit

5

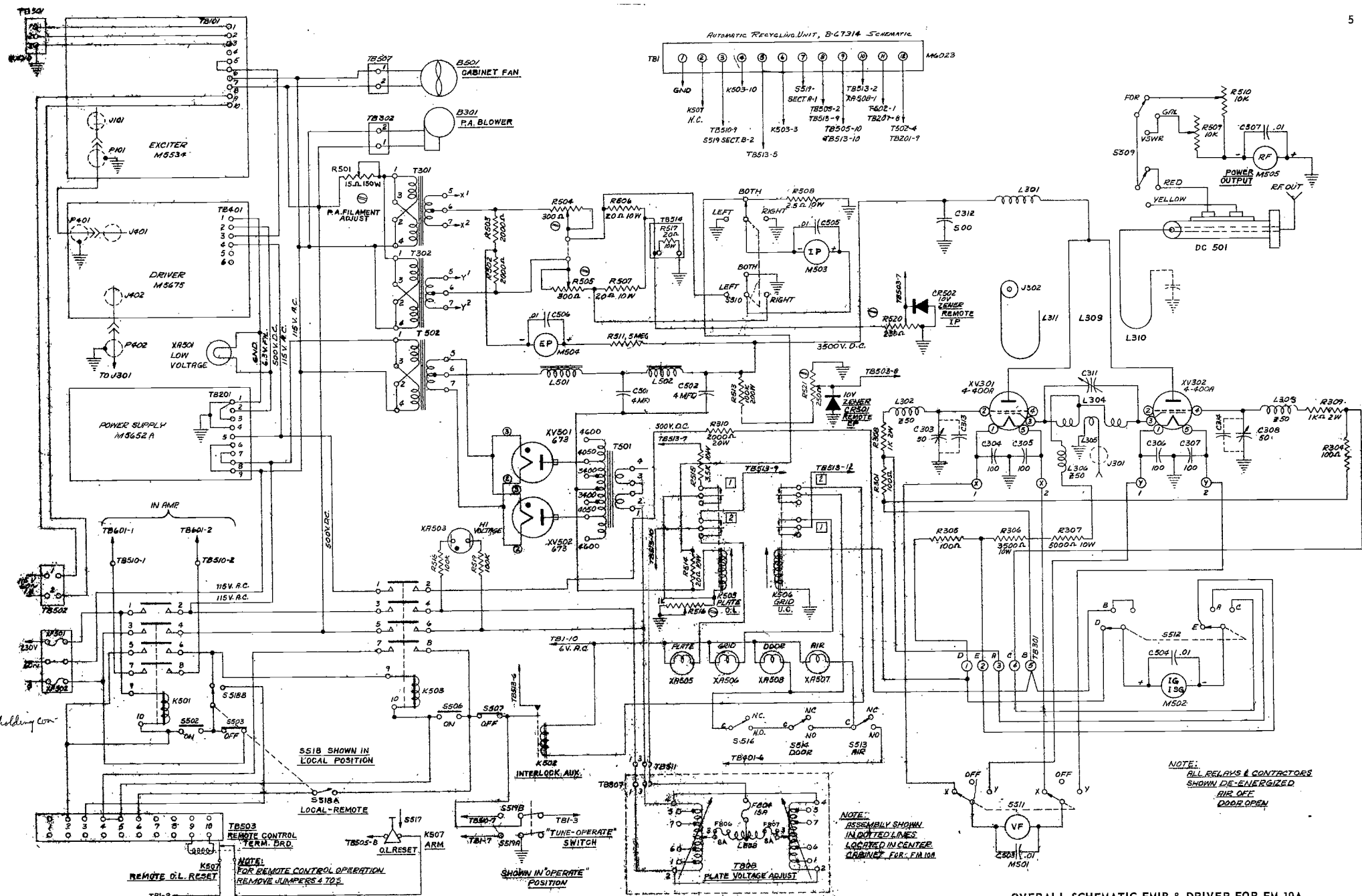

K501/5-6 holding con. leads

SS1B SHOWN IN LOCAL POSITION

SS1A LOCAL-REMOTE

TB503 REMOTE CONTROL TERM. DRD.

NOTE:
FOR REMOTE CONTROL OPERATION REMOVE JUMPERS 4 TO 5

TB1-2

TB407 S518 S519

TB408 S520 S521

TB409 S522 S523

TB410 S524 S525

TB411 S526 S527

TB412 S528 S529

TB413 S530 S531

TB414 S532 S533

TB415 S534 S535

TB416 S536 S537

TB417 S538 S539

TB418 S540 S541

TB419 S542 S543

TB420 S544 S545

TB421 S546 S547

TB422 S548 S549

TB423 S550 S551

TB424 S552 S553

TB425 S554 S555

TB426 S556 S557

TB427 S558 S559

TB428 S560 S561

TB429 S562 S563

TB430 S564 S565

TB431 S566 S567

TB432 S568 S569

TB433 S570 S571

TB434 S572 S573

TB435 S574 S575

TB436 S576 S577

TB437 S578 S579

TB438 S580 S581

TB439 S582 S583

TB440 S584 S585

TB441 S586 S587

TB442 S588 S589

TB443 S590 S591

TB444 S592 S593

TB445 S594 S595

TB446 S596 S597

TB447 S598 S599

TB448 S600 S601

NOTE:
ASSEMBLY SHOWN IN DOTTED LINES LOCATED IN CENTER CABINET FOR FM-10A

NOTE:
ALL RELAYS & CONTACTS SHOWN DE-ENERGIZED AIR OFF DOOR OPEN

INSTRUCTION BOOK
FOR
M5534 STEREO FM EXCITER

I.B. #888 0773 001

Gates Radio Company
Quincy, Illinois

ADDENDA

M-5534B STEREO FM EXCITER

The values of C161 and C163 have been set to allow a gentle roll off below 100 cycles audio response. This is done to prevent low frequency transients and thumps from causing excessive deviation and loss of carrier from momentarily kicking the transmitter off the air. These low frequency transients and thumps may exist in equipment external to the Exciter Unit, such as when the tone arm on a turntable is dropped.

3/8/62

M-5534B Stereo FM Exciter

ADDENDUM

M5534, M5534A, M5534B

M5674, M5673, M5672 EXCITERS

The oven thermostat in HR101 has been changed, and the oven pilot light may seem to indicate erratic oven cycling. This is normal for this type of thermostat, however, and is not an indication of a defective oven.

6/6/62

Gates Radio Company
Quincy, Illinois

INDEX

M5534 EXCITER

(Freq. Range 88 - 108 MC)

	Page
Specifications	1
Introduction	2
Installation	2
Pre-operation	3
Daily Operation	4
Theory of Operation & General Explanation of Circuitry	5 - 20
A. Frequency Multipliers, V-105 - V112	5
B. Power Amplifier Stage, V113	10
C. Derivation of Frequency Modulated Pulses, V101 - V104	10
D. Distortion Control, C110 - R119	14
F. Audio Amplifier, V114 - V115	15
G. Regulated Power Supply, V116 - V120	16
H. Crystal Heater Circuit	18
I. Fusing	18
J. Line Filters, (located at TB101)	18
K. Pre-emphasis and De-emphasis	19

Drawings included within text of theory of operation:

Fig. 1: Frequency Multiplier Circuit Tripler	5
---	---

	Page
Fig. 2: Typical Recovered Waveform, Frequency Tripler	6
Fig. 3: Frequency Multiplier Circuit, Doubler	7
Fig. 4: Typical Recovered Waveform, Frequency Doubler	8
Fig. 5: Typical Waveform, Output of V101	11
Fig. 6: Typical Waveform, Output of V102	11
Fig. 7: Typical Waveform, Output of V103 (V104 removed)	11
Fig. 8: Typical Waveform, Output of V103 (V104 in place)	12
Fig. 9: Typical Waveform, Output of First Section, V104	12
Fig. 10 & 11: Derivation of frequency Modulated Pulses from a Sawtooth waveform (between pages	13 - 14
Fig. 12: Driving Pulse for Frequency Multiplier Stages	15
Fig. 13: Simple Pre-emphasis circuit	20
Fig. 14: Simple De-emphasis Circuit	20
General	22
DC resistance of Frequency Multiplier Coils L101 thru L113 and Capacitor Values Across Them	23
Coupling Exciter to a Following Stage	23
Efficiency Calculations of V113 Stage	24
Typical DC Test Point Voltages	26
Proof of Performance Data	27
Setting Exciter Unit to Proper Carrier Frequency	28
Distortion Measurements and Adjustments	28
Frequency Response Measurements and Adjustments	28

	Page
FM Noise Measurements	31
AM Noise Measurements	31
Typical Proof of Performance Readings	32
Proof of Performance Data Sheet (This data sheet is located at the very back of the instruction book. It is filled out only when the exciter unit is shipped by itself. When exciter unit is shipped as an integral part of another unit, this data will be included with the overall data sheet for the transmitter.)	
Maintenance	33
Troubleshooting	34 - 40
No Carrier	34
Low Carrier	34
Intermittent Carrier	35
Oscillation	36
Carrier Off Frequency	36
High Distortion	37
Improper Frequency Response	38
Will Not Modulate at all	38
FM Noise	38
AM Noise	39
Typical RF Voltage Measurements	39
Electrical Parts List	1 - 4
Guarantee	1 - 2

Drawings at the back of the book in the order referred to in the text:

- A-31359 General Layout of Exciter Unit
- 838 0060 001 Schematic, Stereo FM Exciter
- C-77972 Functional Block Diagram, Exciter Unit
- A-31143 Schematic for Plug-in Pads used in Gates FM Transmitters
- ES-6170 Standard 75 microsecond Pre-emphasis Curve
- A-4165 Test Set-up for FM
- B-65626 Typical Waveforms Existing in Stages V101 thru V104.
- B-65625 Typical Waveforms Existing in States V105 thru V110

Tables and charts included within text of book that are helpful in troubleshooting:

DC resistance of Frequency Multiplier Coils L101 thru L113	23
Typical DC Test Point Voltages	26
Typical RF Voltage Measurements	39
Proof of Performance Test Data Sheet	

SPECIFICATIONS

Power Output:	0-10 Watts, continuously variable.
Frequency:	88 - 108 Mc.
RF Output Impedance:	51 - 72 Ohms.
Frequency Stability:	±.001%.
Type of Oscillator Circuit:	Direct Crystal Control.
Type of Modulation:	Phase Shift Employing Pulse Techniques
Modulation Capability:	+100 kC 100% modulation equals ±75 kC
Audio Input Impedance:	600 Ohms.
Audio Input Level for 100% Modulation at 400 cycles:	+10 dBm, ±2 dB.
Overall Audio Frequency Response:	Within 1 dB of standard 75 micro- second pre-emphasis curve or flat ±1 dB 50 to 15,000 cycles depending on specifications of plug-in audio pad.
Distortion at 100% Modulation:	1% or less, 50 to 100 cycles. .5% or less, 100 to 10,000 cycles. 1% or less, 10,000 to 15,000 cycles.
FM Noise:	65 dB below 100% modulation at 400 cycles or better.
AM Noise:	60 dB below equivalent 100% amplitude modulation.
Power Input:	Approximately 120 watts when exciter is putting out full 10 watts. (1 ampere at 117 volts). Approximately 6 watts (intermittent) crystal oven circuit.
Tube Complement:	7 - 6AU6 1 - 6AQ5 3 - 6J6 1 - 12AT7 3 - 12AX7 2 - 0A2 1 - GZ34/5AR4 1 - 6080 1 - 6360

5/26/58

-1-

M5534

INTRODUCTION

All FM transmitters require a device that will supply an RF driving voltage of sufficient amplitude to drive a succeeding amplifier stage to the required output power level. In addition, this device must have necessary provisions made for frequency modulating the carrier the proper amount.

These requirements are filled by the M5534 Exciter Unit. The exciter panel is standard 19" wide for rack mounting. Height is 14". A rear dust cover is provided that extends 2½" beyond the back of the panel. This dust cover is held on by four "acorn" nuts easily removed from the front of the panel. The highest unit on the front of the panel is the crystal oven which extends 4½" beyond the panel proper.

The unit is complete with its own power supply. It is light in weight (21.5 lbs.). This makes it very easy to remove the unit from the cabinet or rack in which it is mounted and to place it on a bench. All that is needed to operate the unit is an AC cord connected from TB101-7 & 8 to a 117 V. a.c. outlet.

INSTALLATION

Generally speaking, when the exciter unit is received at the point of operation, it will be mounted in a cabinet along with additional amplifier stages. The unit finds its greatest usage in driving 50 watt and 250 watt amplifier stages. With some additional external metering, the unit becomes a complete 10 watt FM transmitter.

Forced air cooling is not required for the unit. Sufficient ventilation should be allowed to provide normal circulation and updraft at least for the front of the panel where all of the tubes are mounted.

External wiring to the unit consists of the following:

1. A shielded, twisted pair cable that connects to TB101-2, 2, 3. The shield should connect to TB101-3 which is ground. These are the audio input terminals. Audio requirements for 100% modulation are approximately +10 dBm and input impedance is 600 ohms.
2. Two wires that connect to TB101-7, 8. These wires are to provide operating voltages for the unit. Requirements are 117 V AC at 1 ampere.
3. Two wires to connect to TB101-9, 10. This provides operating voltage for the crystal oven. Requirements are 117 V AC at about 6 watts intermittent service.

In addition, if the exciter unit is used to supply B+ to some other unit, a wire must be connected from TB101-6 to the other unit. And additional 20 to 30 ma. at 320 volts may be drawn from this terminal when the exciter is transmitting a full 10 watts. If output power from the exciter unit can be reduced to 3 or 4 watts, up to 50 ma. may be drawn from TB101-6.

If the power amplifier stage of the exciter unit (V113) is to be externally metered, the jumper connecting TB101-5 and 6 should be removed. A wire should then be connected from TB101-5 to the positive terminal of the external milliammeter and a wire should be connected from TB101-6 to the negative terminal of the milliammeter. The final stage will draw about 65 ma when output power is 10 watts. The external milliammeter should have a minimum full scale deflection of 100 ma. If tubes and/or other components have been removed for shipping, refer to drawing A-31359 for general location of parts.

PRE-OPERATION

In almost all cases, the exciter unit has been properly tuned up to customer frequency at the Gates plant. If all tubes and other components are properly in place, wires connected, etc., the exciter may be placed into operation by turning S101 to the "ON" position. This switch is located in the primary circuit of T103. Reference to drawing A-31359 will help in getting familiar with general location of major components. When it is turned "ON" both the filament voltage and the B+ voltage come on to all tubes. The rectifier tube is of the slow heating, indirect cathode type tube and positive voltage will not exist for perhaps 20 seconds. After this length of time, the exciter power output will come up.

The only adjustments that will have to be made are to tune C159 (output coupling) and C158 (V113 plate tune) for maximum power output into a load, following stage, or antenna. Final adjustment of C158 and C159 should be done only after the exciter has come up to full operating temperature. This will take about 15 minutes after first turning the unit on. Stray capacities of tubes tend to change slightly as the tube warms up. A small change of even 1/4 mmf. can considerably de-tune a circuit operating in the VHF range.

Frequency adjust control C102 should be set to the value given in the factory test data sheet. Oven pilot lamp A101 will start cycling after the oven heater has been on for about 20 minutes. The crystal oven doesn't really stabilize until it has been on for about an hour. If after this length of time, the carrier center frequency does not agree with that as shown on a frequency monitor of known accuracy, re-adjust C102 for proper center frequency.

Normal cycling of oven pilot lamp A101 will be "ON" 1/3 and "OFF" 2/3 time wise for a room temperature of 75 degrees.

A quick check of the B+ voltage is advisable. This can be done by placing the negative probe of a 20,000 ohms per/volt meter into a black test point. TP120 or TP121, and the positive probe into TP119. The voltmeter should read near +320 volts DC.

DAILY OPERATION

It is considered general good practice to arrange wiring and control circuits so that the crystal oven heater operates independently of the main power switch. If this is done and the crystal oven remains "ON" all the time, the exciter will be close to center frequency even from a cold start. Power requirements for the oven are about 6 watts and this only intermittently. On a presumed basis of the oven being "ON" one third of the time, the oven would use only 2 watts of power per hour.

Assuming that the crystal oven is "ON" continuously, then the only thing that needs to be done in the normal days operation is to turn the main power "ON" when starting the broadcasting day and "OFF" when finished. In most cases, this will be accomplished when the low voltage switch is turned on in the transmitter whether the transmitter be 250, 1000 or 5000 watts.

If the exciter is turned on 10 or 15 minutes before "AIR" time, no other adjustments should be necessary. The exciter will reach 80 to 90% of full power in about 5 minutes and full power in 10 to 15 minutes. This assumes that the unit was "fine tuned" while thoroughly warmed up.

5/26/58

- 4 -

M5534/M5672

THEORY OF OPERATION AND GENERAL EXPLANATION OF CIRCUITRY

Of all the known methods used to generate a frequency modulated signal the one used in the exciter unit is the simplest and most straight-forward. Since the signal generation depends upon direct crystal control, the output frequency will be very stable. In addition, tuned circuits will be uncritical in operation and low cost receiving type tubes may be used in the majority of circuits.

Frequency Multipliers (V105 through V112)

It is standard within the FM broadcast of 88 to 108 MC/s that 100% modulation shall be ± 75 kc/s. It is also required that any FM transmitter operating within this band be capable of ± 100 kc/s swing. This means that a 100 MC/s carrier for example, must be capable of instantaneously moving from 99.9 MC/s to 100.1 MC/s. This moving back and forth or frequency swing as it may be called is caused by applied audio. The carrier, therefore, instantaneously swings back and forth the required amount at the audio frequency rate. The amount of frequency swing is also referred to as frequency deviation.

There are, at present, no known circuits that will produce the required amount of frequency deviation directly at operating frequency. It is necessary then to substitute the best circuit possible that will produce maximum frequency deviation and then multiply or increase the amount of frequency deviation by additional circuits. This is the purpose of frequency multiplier circuits.

Assume that we have a circuit operating at 116 kc/s that is capable of producing instantaneous frequency excursions of 116 cycles when the circuit is modulated by an audio frequency. The best method to increase both frequency deviation due to modulation and to raise the frequency is to use a frequency multiplier circuit. Refer to Fig. 1.:

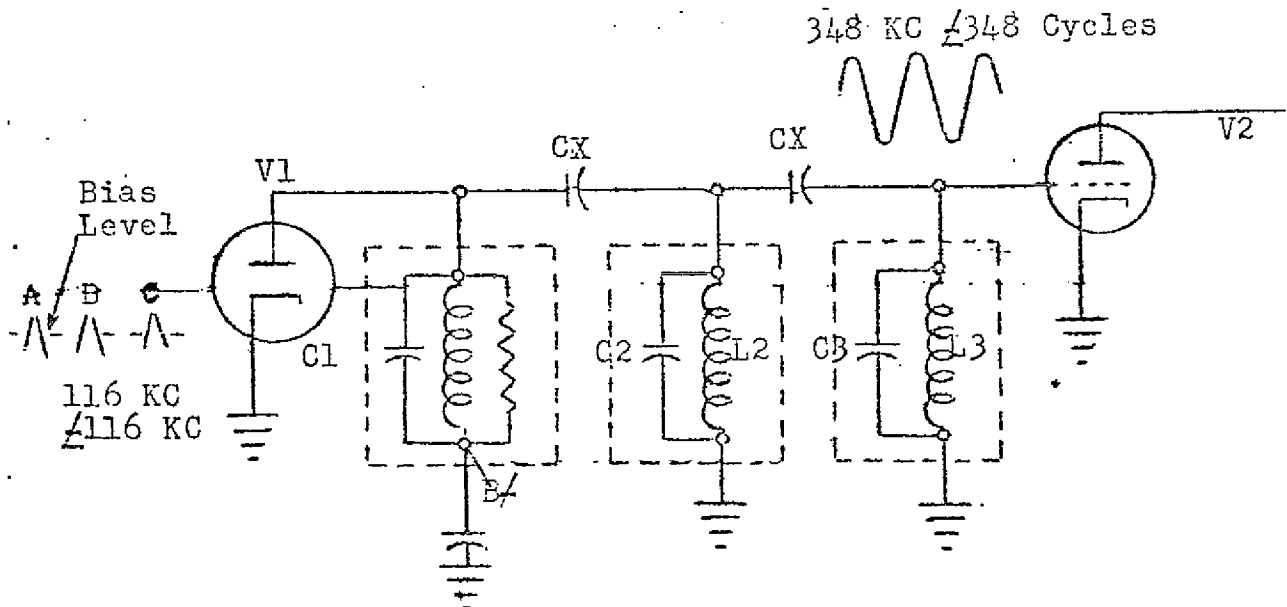

Fig. 1, Frequency Multiplier Circuit, Tripler.

A series of sharp spikes or pulses is being applied to the grid of V1. For the moment assume no modulation. The pulses are being applied at a frequency rate of 116 kc/s. The plate circuit of V1 consisting of L1, C1 is tuned to three times 116 kc/s or 348 kc/s. As each of the sharp spikes occurring at 116 MC/s. arrives at the grid of V1, the tube suddenly conducts and shocks the plate circuit of V1 into oscillation at its resonant frequency of 348 MC/s. If a scope were connected directly to the plate of V1, these oscillations would appear as shown in Fig. 2 below:

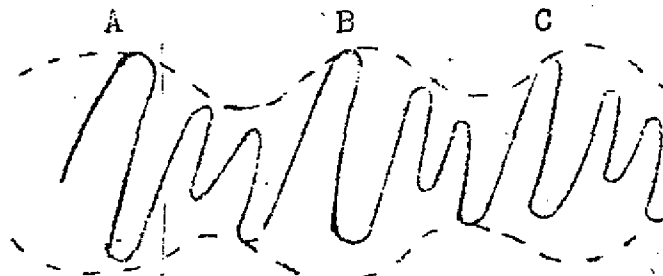

Fig. 2, Typical Recovered Waveform Frequency Tripler

These oscillations it will be noted are damped. This is a necessary condition for a frequency multiplier circuit and indicates a lowering of the "Q" or efficiency factor of that circuit. In fact, the "Q" has been intentionally lowered by a resistor connected across L1. This resistor also broadens the bandwidth of the L1, C1 combination to the necessary 35 kc bandwidth.

If the "Q" of the L1, C1 combination were very high and some regeneration were present in V1, the circuit would probably "take off" and oscillate on its own. Even if this did not take place the circuit would be "stiff" in that when the 116 kc. driving pulses shifted due to frequency modulation, the flywheel effect of the plate circuit of V1 would prevent the circuit from following faithfully and distortion would result.

We said that the maximum frequency deviation of our 116 kc driving pulses was ± 116 cycles when modulation was applied. This means that one one-half of the audio cycle, the pulses instantaneously move to 116,116 cycles and on the other half of the audio cycle they move to 115,884 cycles. The effect of this upon V1 is as follows; the plate circuit of V1 which is broadly resonant to 348 kc will instantaneously oscillate at three times 116,116 cycles or at 348,348 cycles and then instantaneously oscillate at three times 115,884 cycles or at 347,652 cycles. Total frequency deviation in the plate circuit of V1 due to frequency modulation is thus 348,348 minus 348,000 cycles and 348,000 minus 347,652 cycles or a frequency deviation of ± 348 cycles. The driving frequency of 116 kc has thus been tripled to 348 kc. Frequency deviation due to applied modulation has been tripled from ± 116 cycles to ± 348 cycles. This is the basic reasoning of any frequency multiplier circuit. If the frequency is tripled, frequency deviation due to modulation is tripled. If the frequency is doubled, frequency deviation due to modulation is doubled.

The tuned combination of C2, L2 and C3, L3 form a type of bandpass filter that removes the amplitude variation of 116 kc from the 348 kc signal coming from the plate circuit of V1. The grid current of V2 is thereby fed with a pure sine wave of 348 kc. Bandwidth and coupling is determined by the values used for the two coupling condensers labeled CX. If amplitude variations of 116 kc are not removed from the 348 kc signal, the carrier will tend to become phase modulated at the driving frequency of 116 kc causing spurious frequencies to appear at the output of the exciter. Necessary bandwidth of circuitry between V1 and V2 is determined by the highest modulating frequency and the frequency deviation. For these circuits it figures out to be about 35 kc.

Circuitry between V1 and V2 described in the previous paragraphs has for all practical purposes been "lifted" and used in the M5534 exciter unit. Referring to drawing which is the overall schematic, V105 has been substituted for V1 in Figure 1 and V106 has been substituted for V2. The intervening circuitry between V105 and V106 on the overall schematic corresponds closely to intervening circuitry between V1 and V2 in Fig. 1.

It was explained previously how a series of pulses occurring at 116 kc with a frequency deviation of ± 116 cycles could be converted to a sine wave at 348 kc with a frequency deviation of ± 348 cycles. Let us observe the action of a frequency doubler stage with the sine wave of 348 kc applied. Refer to Fig. 3.

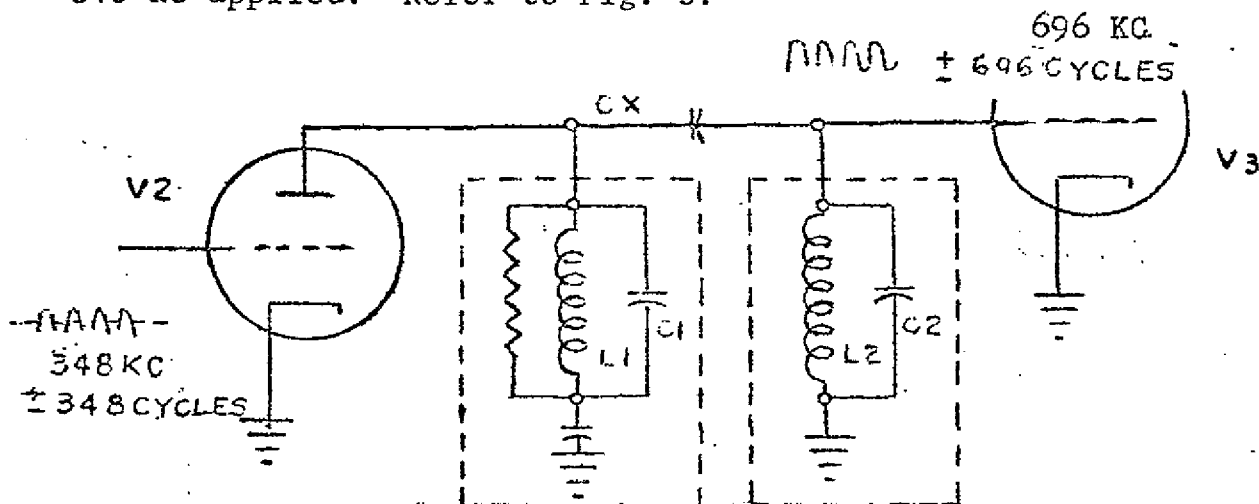

Fig. 3, Frequency Multiplier Circuit, Doubler.

In Fig. 3, a sine wave of 348 kc is being applied to the grid of a vacuum tube, V2. V2 has been biased well into the class "C" region to increase efficiency. V2 will, therefore, not be conducting over much of the applied AC signal at 348 kc. This is shown by the dotted lines drawn through the 348 kc signal at the grid of V2. As the applied signal rises over the dotted lines, V2 suddenly conducts and

shock excites the resonant circuit in the plate side of V2 into oscillation at its resonant frequency which in this case would be two times 348 kc or 696 kc. The waveform observed at the plate of V2 would appear as shown in Fig. 4 below.

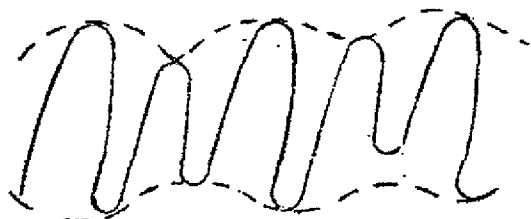

Fig. 4, Typical Recovered Waveform, Frequency Doubler

The waveform observed in Fig. 4 is again damped similar to the waveform noted in Fig. 2 for the frequency tripler stage. Now, however, every other cycle is the same instead of every third cycle. In addition, the amplitude component shown by the dotted lines will be at the 348 kc driving frequency. This amplitude component is removed by the filtering action of L2, C2 and proper bandwidth of approximately 35 kc is determined by coupling condenser CX.

When the driving frequency of 348 kc applied to the grid of V2 instantaneously swings to 348 kc plus 348 cycles or 348,348 kc, the tuned circuit in the plate side of V2 will double to two times 348,348 kc or 696,696 kc. When the driving frequency of 348 kc instantaneously swings to 348 kc minus 348 cycles or 347,652 kc, the tuned circuit in the plate side of V2 will double to two times 347,652 kc or 695,304 kc. It is apparent that while our frequency was doubled from 348 kc to 696 kc, our deviation was also doubled. 696,696 minus 696 kc gives us 696 cycles deviation on the positive side. 696 minus 695,304 gives us 696 cycles deviation on the negative side.

Circuitry of Fig. 3 has again been "lifted" and substituted directly into the M5534 exciter unit. On the overall schematic, V2 of Fig. 3 corresponds to V106 and V3 of Fig. 3 corresponds to V107. Intervening circuitry between V2 and V3 of Fig. 3 corresponds closely to the intervening circuitry between V106 and V107.

We have seen how a signal of 116 kc with a frequency swing of 116 cycles has been raised to a frequency of 696 kc with a frequency swing of 696 cycles with two stages of frequency multipliers. It remains for the succeeding frequency multiplier stages following V107 to raise the frequency to approximately 100 Mc and frequency deviation due to modulation to 100 kc.

If we take our original signal of 116 kc (.116 Mc) and by frequency multiplier stages multiply the frequency 864 times, the output frequency will be 100.224 kc or approximately 100.2 Mc. Our original signal had a frequency swing of .116 cycles or .116 kc. Multiplying this frequency swing of 864, the final output frequency of 100.2 Mc will have a frequency swing of 100.224 kc. It is apparent that these figures meet with the FCC requirements of a capability of 100 kc swing. The frequency multiplication factor of 864 has been used in the M5534 exciter unit. Actually, the 116 kc originating signal is capable of greater swings than 116 cycles at audio modulating frequencies higher than about 40 cycles. The lowest audio modulating frequency is usually the most difficult to reproduce faithfully in any frequency modulation system. Too, in normal operation the maximum swing at output frequency is limited to 75 kc swing (100% modulation 88 to 108 Mc.). This means that the original signal has to have a swing of only $\frac{75 \text{ kc}}{864}$ or 87 cycles which makes the problem

of low distortion easier by backing down somewhat from the maximum requirements of the system.

Stages V105 through V112 of the M5534 exciter are all frequency multiplier stages and their operation follows closely the reasoning explained in a preceding paragraph. All of the multiplier stages in the M5534 exciter either double or triple the frequency. The multiplication factor of each stage may be determined by reference to functional block diagram C-77972. This drawing also shows the multiplication factor of each stage, frequency range of each stage, how many times crystal frequency has been multiplied and general location of test points.

V105 through V109 are so called "single ended" stages and are all 6AU6 pentode tubes. V110 through V112 are so called "push-push" stages and are all 6J6 twin triode tubes. The grids of these "push-push" stages are connected in normal "push-pull" fashion but the plates are connected in parallel. With this type of connection, the plate circuit receives two pulses for every complete cycle of RF drive in the grid circuit. This makes it a natural for frequency doubling service since this circuit will not amplify a fundamental frequency and will not triple. It will only double or quadruple. The quadruple frequency will, however, be out of the tuning range of the stage and in addition will be much lower in output.

Necessity or use of circuitry between V109 and V110 may be questioned. Reference in particular is made to J101, J102 and the short coaxial cable jumper between them. The combination of L110, C137 and C138 tunes the plate circuit of V109 to the proper resonant frequency. C137 and C138 are impedance transforming condensers that change the high impedance output of V109 to about 51 ohms at J101. This makes it possible to carry the output of V109 over a considerable length of coaxial cable to another amplifier stage without serious attenuation. From this external amplifier, another length of coaxial cable may be brought back to J102. The condenser combinations of C139, C140 and C141 then transform the 51 ohm

impedance back to a high impedance in addition to resonating L111 to operating frequency.

J101 and J102 are used specifically for the purpose of inserting multiplex sub-carriers on the main carriers. If the main carrier is not being multiplexed, J101 connects directly to J102 by a short jumper and for all practical purposes L110 is capacitively coupled to L111 and the operation of V109 and V110 is treated the same as any of the other frequency multiplier stages in the exciter.

Power Amplifier Stage (V113)

Output power from the last frequency multiplier stage, V112 is on the order of .2 watts. This power is inductively coupled to the grid circuit of V113, the power amplifier stage. Power output of this amplifier stage is on the order of 10 watts. V113 consists of a self-neutralizing, twin tetrode with a common screen and cathode. Coupling between L116 (plate circuit of V112), and L117 (grid circuit of V113) is variable so that maximum drive may be coupled into V113. The coupling between L118 (plate circuit of V113) and L119 (output coupling coil) is also adjustable for proper loading of the plate circuit of V113 so that maximum efficiency may be enjoyed. In addition, coupling may also be varied considerably by C159 to match a wide variation of load impedances and terminations as may occur when coupling the exciter unit into a succeeding amplifier stage. An output control (R155) varies screen voltage from zero to about 175 volts dc so that the amplifier stage may be tuned up for best efficiency and the output power adjusted exactly to the desired amount. A cathode resistor (R153) biases the amplifier stage to a safe value to prevent serious damage in case of drive failure.

Derivation of Frequency Modulated Pulses (V101 through V104)

In the section devoted to the explanation of frequency multiplier stages, it was shown how a series of sharp, positive pulses of limited frequency swing could be changed into a sine wave of a higher frequency and higher frequency deviation.

Tube V101 through V104, in the exciter, are the circuits that originate frequency modulated pulses. V101 is a crystal controlled oscillator stage. This stage is a form of Pierce oscillator with feedback being controlled by C103 and C175. The crystal is in the grid circuit along with the frequency vernier by which the carrier can be set exactly to center frequency. The value of C103 will, to a certain extent, also determine the exact output frequency. The output of V101 is a sharp, negative pulse that appears much as in Fig. 5.

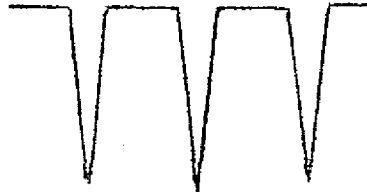

Fig. 5, Typical Waveform, Output V101

The negative pulse of Fig. 5 is applied to the first section of V102, a shaper stage that also inverts the pulse so that it can be used to drive V103. The second section of V102 is a cathode follower section that changes the high impedance output of the first section of V102 to a low impedance. The output pulse from the second section of V102 appears as in Fig. 6.

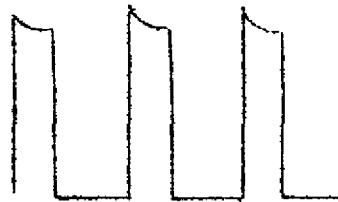

Fig. 6, Typical Waveform, Output V102

The pulse of Fig. 6 is applied to the first section of V103. V103 is essentially a sawtooth oscillation stage that fires only when a driving pulse is applied. The output pulse of the first section of V103 is applied both to V104 and the second section of V103. The second section of V103 is used mainly to provide feedback to the first section of V103 and give greater linearity of the sawtooth waveform. The output of the first section of V103, as applied to V104 is shown in Fig. 7.



Fig. 7, Typical Waveform, Output V103
(V104 removed)

It should be emphasized that the waveform shown in Figure 7 is what would appear with no loading on the circuit or with the following tube, V104 removed from the circuit. When V104 is inserted in the circuit, the waveform will be clipped. The dotted lines shown in the waveform of Figure 7 explain the necessity of the second section of V103. The second section of V103 provides feedback of such a nature so that the leading edge of the sawtooth is "pulled up" and made linear. If the second section of V103 were not in the circuit, the sawtooth waveform would tend to follow the dotted lines in Figure 7.

When the sawtooth waveform of Figure 7 is applied to V104, the modulator tube, the waveform will appear as in Figure 8 if bias has been properly set. Dotted lines show the waveform as it would appear if V104 were not in the circuit.

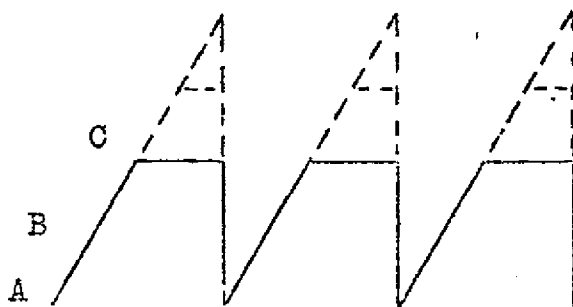

Figure 8, Typical Waveform, Output of V103 (V104 in place)

The waveform of Figure 8 has been clipped off due to the sudden conduction of the first section of V104. When this happens, a sharp negative spike appears in the plate circuit of V104. This spike will have the general appearance of Figure 9.



Figure 9, Typical Waveform, Output V104 (first section)

Referring again to Figure 8; it is possible by means of R119, the distortion control to vary the conduction point on the leading edge of the sawtooth waveform. It could be at any point on the leading edge such as A, B or C or any other intermediate point. Regardless, V104 will conduct at the repetition rate of the sawtooth waveform.

Refer to Figure 10. A sawtooth waveform occurring at a repetition rate of 116 kC is shown. Bias has been set so that the tube conducts at about the center of the leading edge of the sawtooth waveform. Below the sawtooth waveform being applied to the grid of V104 is shown the negative pulses that occur in the plate circuit of V104 as the tube conducts.

In Figure 11, the same condition is shown with the exception that a sine wave of approximately 7,250 cycles has been super-imposed upon the sawtooth waveform. This is actually what takes place when modulation is applied to the cathode circuit of the first section of V104. The applied modulation acts in series with the fixed cathode bias section of V104 changing at an audio rate. Making the cathode more positive is identical to making the grid more negative. So, when the positive crest of the applied audio modulation arrives at the cathode of the first section of V104, the grid in effect has become more negative. This means that the sawtooth waveform applied to the grid of the first section of V104 has to rise to a higher level before conduction of the first section of V104 takes place. This represents a time lag or phase shift since the pulses in the plate circuit will not be equally spaced with modulation being applied. After the positive crest of the audio modulation has been reached and starts to fall off, the sawtooth waveform has to rise to a succeeding less and less value for the tube to conduct. This means that the pulses in the plate circuit will be occurring sooner than if no modulation were present and is another way of saying that the frequency is instantaneously swinging to a higher value. The frequency swings to an instantaneous higher value from the crest of a positive cycle to the crest of a negative cycle. From the crest of a negative cycle to the crest of a positive cycle of modulation, the point of conduction is succeeding less and the frequency or timing of the negative pulses instantaneously swings to a lower frequency.

De-emphasis/Pre-distorter C112

In Figure 11, a modulation frequency of approximately 7,250 cycles was assumed. This means that the length of time of one modulating cycle is $1/7,250$ or about 138 microseconds. During this same length of time, 16 complete cycles at the pulse repetition rate of 116,000 cycles will have occurred.

Suppose the modulating frequency was doubled to 14,500 cycles; during 138 microseconds of time, two complete cycles of audio will have passed. Each cycle of audio at 14,500 will instantaneously swing the 116 kC pulses above and below the average repetition rate (center frequency) as did each cycle of audio at 7,250 cycles and by the same amount. However, the same amount of swing will occur in $1/2$ the time. The same amount of frequency deviation occurring in $1/2$ the time is synonymous with saying the frequency deviation

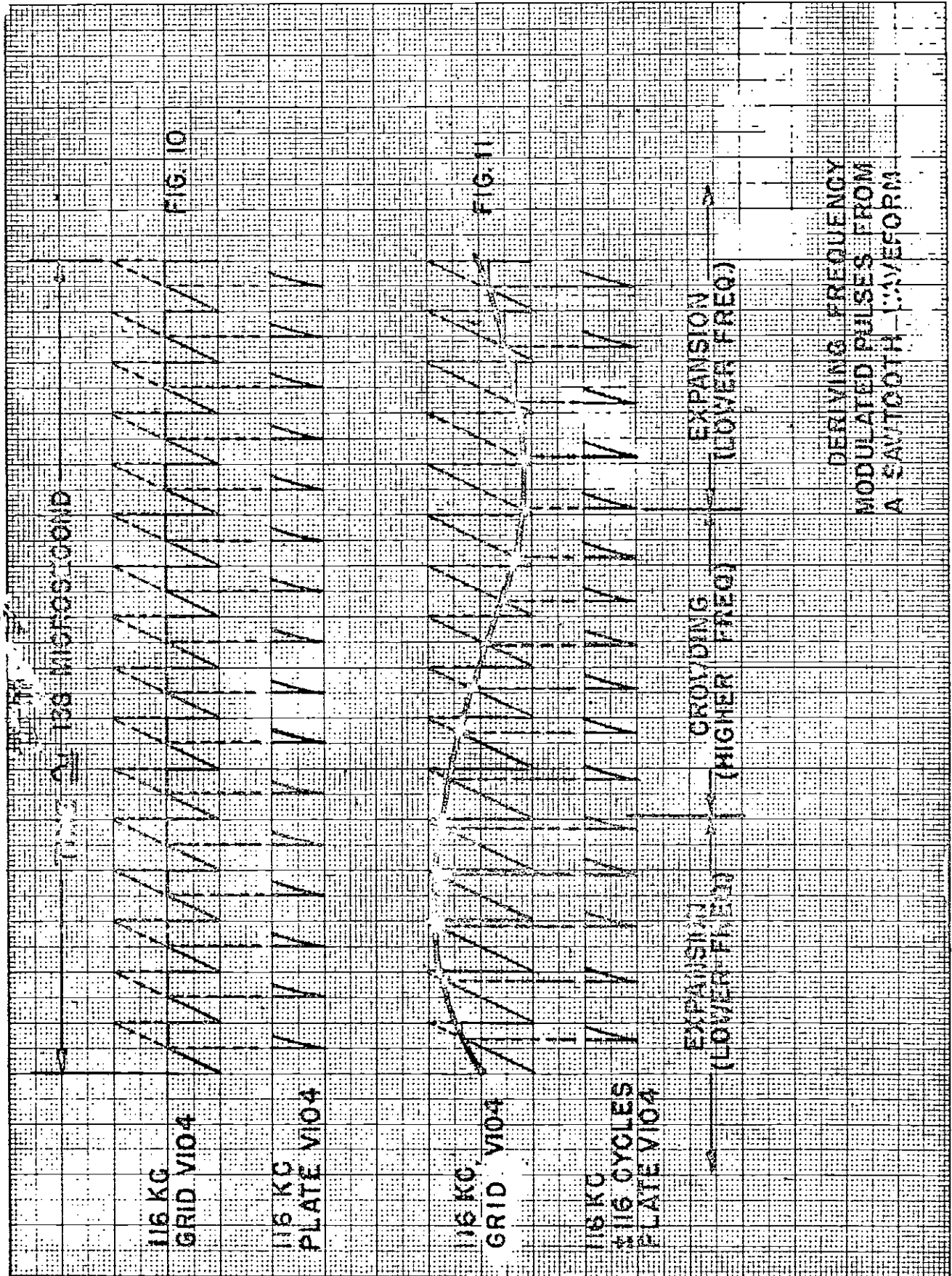

has doubled. If the amplitude of the audio modulating frequency is kept constant, the frequency deviation will double every time the modulating frequency is doubled. This would make the system a true phase modulation system. This means that the deviation at 15,000 cycles audio modulation would be 15,000/50 or 300 times as great as at 50 cycles audio modulation. This is undesirable since 75,000 cycles deviation represents 100% modulation and we want all audio frequencies to approach this limit.

If only one-half as much audio modulating voltage were fed to the cathode of the first section of V104 at 14,500 as was fed to the cathode at 7,250 cycles, the desired result would be accomplished. Circuitry that does accomplish this consists of R168 in series with C112. C112 is located in the cathode circuit of the first section of V104. Audio modulating voltage is obtained from V115 (6AQ5) at the cathode. The combination of R168 and C112 is arranged to have a 6 dB per octave "roll-off". This means that if the audio output level remains constant at the output of V115 regardless of frequency, the modulating audio seen at the cathode of V104 will be only one-half as great every time the frequency is doubled. The series combination of R168 in series with C112 is known as de-emphasis since it de-emphasizes the higher frequencies. It is sometimes referred to as a pre-distorter.

Distortion Controls, C110 & R119

It is necessary that the audio modulating voltage applied to the modulator stage V104 be faithfully translated into alternate rarefactions and compressions of the pulse repetition rate. To accomplish this purpose, several conditions must be fulfilled. The modulator tube must have a long, linear E_g , I_p curve. The sawtooth voltage being applied to the grid of the modulator tube must have a linear leading edge. The bias control must be set to the approximate center of the sawtooth pulse.

Tube linearity is fixed by the tube manufacturer. Linearity of sawtooth voltage applied to the modulator tube can be controlled. In Figure 7, the sawtooth output of the first section of V103 was shown. Dotted lines show the approximate waveform without the feedback circuit of the second section of V103. The amount of feedback is determined by C109. In practice, the sawtooth waveform is somewhat over-compensated in that the top of the sawtooth waveform is pulled up to where a slight sag develops in the center of the leading edge. The effect of C111 and C110 (distortion adjust control) is to round off the top of the sawtooth waveform and make it straight. Variations of parts values and variations of pulse frequencies make it impossible to build in perfect linearity. Distortion control C110 is, therefore, set for maximum linearity of sawtooth when the exciter unit is tuned-up on frequency. Distortion control R119 is set so that the sawtooth waveform is "clipped" in the approximate center of the linear leading edge. These variable parameters make it possible to make use of low coast receiving type tubes in the modulator section.

The second section of V104 is used mainly to invert the negative going spike obtained at the plate of the first section. This spike is "sharpened up" somewhat by a differentiating circuit consisting of C113 and R116. By means of plate saturation, amplitude limiting is also accomplished in the second section of V104. The waveform appearing at the output of the second section of V104 and as observed at TP104 would appear as shown in Figure 12. This is the pulse used to drive the frequency multiplier stages.

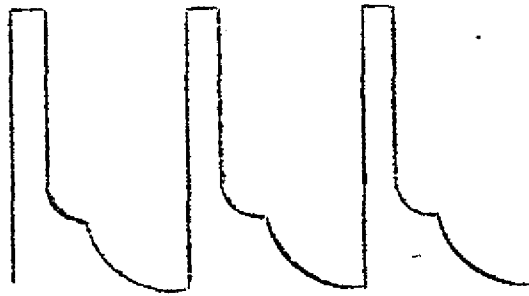

Figure 12, Driving Pulse for Frequency Multiplier Stages

Audio Amplifier, V114 and V115

It is rather common practice that the necessary input level to modulate an FM transmitter 100% be +10 dBm and that input impedance be 600 ohms. Audio amplifier stages V114, V115 and associated circuitry embrace these standards.

Approximately 30 volts RMS of audio is required at the output of the audio amplifier stage as measured at TP118 to modulate the FM carrier 100%. The output of the audio amplifier stage should be of fairly low impedance. For this reason, the audio output stage of the exciter is a cathode follower (V115, type 6AQ5 tube). V114 and V115 work together as a unit since they operate within a feedback loop. The negative feedback is provided by condenser C163 and R158, R159 in series. Varying the value of C163 will effect the response somewhat at the low end of the audible spectrum from 50 to 100 cycles. Some of the feedback at the high end of the audio spectrum, (10,000 to 15,000 cycles) may be relieved to compensate somewhat for improper high frequency audio response. This is accomplished by C160.

Audio input stage V114 is driven by audio input transformer, T102. The output of this transformer is high impedance to match the grid circuit of the first stage. The input of T102 matches 600 ohms balanced input. A plug-in pad, AT101, is stationed between the input connections to the input transformer T102 and the audio input terminals on TB101. The use of this pad is described fully in the following section on pre-emphasis and de-emphasis. It is sufficient to say at this point that if a purely resistive unit is used at AT101 (non-frequency sensitive) and the audio input level is kept constant regardless of frequency, the overall frequency response of the audio amplifier as viewed at TP118 will be flat. A schematic diagram of AT101 is given on drawing A-31143.

The M5486 pre-emphasis plug-in unit will usually be used when operating the exciter unit within the FM broadcast band of 88 to 108 mc or when the exciter is used to generate the aural carrier for a TV transmitter.

Regulated Power Supply, V116 through V120.

A complete filament and regulated B+ supply is contained on the exciter panel. This makes it possible to remove the exciter panel from its cabinet and operate it independent of any other unit simply by connecting 117 VAC to TB101 terminals 7 and 8.

T103 is capable of providing up to 8 amperes at 6.3 V AC for filament demands. Tubes within the exciter unit draw 5.62 amperes. Rectification of the high voltage provided by T103 is done by means of rectifier tube V116, a type GZ34/5AR4 type tube. V116 has a slow heating cathode so that B+ is not provided for the exciter proper until other tubes in the unit have had time to heat up and draw current. This is a safety factor that tends to prevent arcing and over-dissipation of power supply components.

Filtering of the positive DC voltage is accomplished by L121 and C165/166 which is a dual plug-in capacitor. Series regulation of the filtered, positive DC is provided by a series type regulator tube V117 a type 6080 tube. V118 is a control tube that amplifies minor voltage variations of the regulated output. V119 and V120 are reference tubes. Proper voltage of +320 volts is set by means of voltage adjust control R173.

The regulated supply operates in the following fashion; first, the available positive voltage existing at the plates of V117 must be of a somewhat higher value than actually needed. Reference tube V119 establishes the proper potential of +150 volts at the cathode of V118 and holds it there. Reference tube V120 along with voltage dividers R173 and R152 determine the bias applied to control tube V118. The plate of the control tube V118 is connected to the grids of the series regulator tube V117 and through a large value resistance to B+ (R171). With the voltage adjust control (R173) set for the proper output voltage of around +320 V., a bias will be established between the grid and cathode of control tube V118. This bias will be in the vicinity of -5 volts. Control tube V118 will then conduct and draw plate current through R171 which will establish a bias on the grid of regulator tube V117. This determines the dynamic resistance of series regulator tube V117 which in turn regulates the voltage drop across V117 and the amount of current which can flow through it.

Suppose that some stage in the exciter unit commences to draw more current. When this happens, the voltage put out by the regulated power supply will attempt to fall. This voltage change will be impressed upon the control grid of V118 the control tube through V120 and R173. The control grid voltage of V118 will become less positive and cause V118 to draw less current. The voltage at the plate of V118 will then rise or go more positive as will the grids of V117, the series regulator tube. When the grids of V117 become more positive, the plate or dynamic resistance of V117 will decrease, allowing more current to flow through V117 and decreasing the voltage drop across it. The original "set-up" voltage will then re-establish itself.

V117 the series regulator tube may be looked upon as a potentiometer with the arm of the pot fastened to control tube V118. When the voltage at the plate of the control tube V118 rises, it causes the "arm" (grid V117) of the pot to move in such a direction as to decrease the resistance and raise the voltage supplied to the exciter proper. Conversely, the "arm" moves in the opposite direction if voltage at the plate of V118 falls.

Approximately the same results are accomplished should the line voltage change and the available positive voltage at the plate side of V117 change with it. V118, the control tube, amplifies every minute variations of voltage whether short or long time variations and actually increases the effective filtering of the B+ voltage. Hum and noise output of the regulated power supply is better than 90 dB. The power supply will normally hold its regulation with a line variation of from 105 to 135 V. AC.

Normal current requirements of the exciter proper is in the vicinity of 140 ma. when putting out a full 10 watts. The power supply is capable of supplying an additional 20 to 30 ma. current to other units, such as the screen of a following amplifier stage. This external drain may be increased even further if the power output of the exciter unit can be reduced as is often the case when the exciter is used to drive a following amplifier stage.

Taps are available on T103 that may also be used to compensate for improper line voltages.

Crystal Heater Circuit

Frequency stability of the exciter unit is better than .001% over an ambient temperature range of +10 C. to +60 C. This is made possible by the crystal oven HR101 which maintains the crystal itself at a temperature of 60 C.

Heater voltage of 6.3 V. AC is supplied by T101. When the oven is actually heating, pilot lamp, A101 will be lit. From a cold start, it takes about one-half hour for the oven temperature to stabilize properly. After this period of time, the pilot lamp, A101 will start cycling which indicates that the crystal temperature is under the control of the oven.

Any interference or noise impulses that might be generated by the oven thermostat opening and closing, are damped out by bypass condensers C101 and C176.

Fusing

Both the crystal oven circuit and the primary power input for the exciter unit are fused. A short in either the primary or secondary circuit of T101 will cause F102 (1/8 A.) to blow.

A short of B+ to ground or a shorted filament will cause F101 to blow. F101 is 1.5 A. (Slo-Blo variety). When the exciter is transmitting a full 10 watts output power, current drawn from the 117 VAC line will be about 1 ampere. However, when the exciter is first turned on with the filaments cold, the initial surge is much greater than this. A Slo-Blo fuse must, therefore, be used for F101 to keep its value low enough so that a short in the secondary circuit of T103 will blow the fuse.

Line Filters (Located at TB101)

A group of low-pass filters are located at TB101. They consist of L122 through L127 and C168 through C173. These filters serve to keep any of the various frequencies found in the exciter unit from leaking into the external cabling that is necessary to provide power for the exciter. Their main function though, is to prevent stray RF fields from following the cabling into the exciter. Often, in a higher power transmitter of 1 or 5 kilowatts, a considerable RF field may exist within the transmitter cabinet. If a considerable amount of RF leaks into the exciter circuits, it may cause noise to exist and may influence distortion and overall response.

Pre-emphasis and De-Emphasis

In a true FM transmitter, deviation due to modulation is the same for a given amplitude regardless of the frequency of the modulating signal. Nevertheless, as signals pass through the transmitter, receiver, and space between them, certain amounts of unwanted noise and distortion are super-imposed on the desired program. Consequently, the ratio of the signal to unwanted noise decreases in the higher audio frequencies because program amplitudes in this range do not have the intensity that lower frequencies have.

To avoid degrading reproduction of higher frequency program material due to poor signal to noise ratio in the upper end of the spectrum, a certain amount of added amplification (pre-emphasis) is provided at these frequencies. Results of this process should not sound unnatural when received and the reverse procedure (de-emphasis) is used at the receiver. This combination of pre-emphasis and de-emphasis provides a more uniform signal to noise ratio throughout the audio range.

The fact that pre-emphasis results in a greater bandwidth for a given deviation must be taken into account. However, the possibility of over-modulation is not likely since the high frequency components of the signal originally are weak and pre-emphasis merely brings them up to the level of the low tones.

Pre-emphasis characteristic of an FM transmitter can be specified by a graph ES-6170 showing relationship between the audio input and modulated output. Frequency of the audio spectrum is plotted horizontally and the output of the unit for an input that is constant in respect to frequency is shown vertically. This curve shows that the output remains relatively constant from 50 to about 500 cycles and then rises abruptly to a peak at 15,000 cycles. Since this rise is specified in decibels, a change of 6 dB means a doubling of the amplitude of the signal. Therefore, if the graph shows a rise of 18 dB from 1,000 to 15,000 cycles it means that the amplitude has doubled three times. The resultant output at 15 kC, therefore, is two times two, times two, or eight times the output at 1,000 cycles (approximate). At the receiver the reverse characteristic of pre-emphasis is used, so that natural balance between high and low frequencies is not upset.

Characteristics of pre-emphasis and de-emphasis are normally achieved by simple electrical combinations of resistance and capacitance or resistance and inductance connected to give the desired relationship between input and output voltages of the network. Characteristics of speech are complicated and, therefore, networks chosen represent a compromise between duplicating exact loss of high frequencies and using as few parts as possible.

A simple pre-emphasis network consisting of an inductor and a resistor connected in the grid circuit of a vacuum tube amplifier is shown in Fig. 13. In this circuit audio voltage is impressed across the inductor and resistor in series and the output is

across the inductor. Since impedance of the coil rises with frequency and the resistance remains constant, voltage across the coil rises at the higher frequencies. The ratio of inductance to resistance determines the time constant of the combination and the pre-emphasis characteristic can be specified completely in terms of time constant. When the inductance is given in henries, and resistance in megohms, the time constant is in microseconds. For example, to calculate the time constant of the network Fig. 13, which contains a resistance of .1 megohm and an inductance of 7.5 henries; the time constant equals L/R equals $7.5/1$ equals 75 microseconds. For the specific ratio of inductance to resistance in Fig. 13 the graph of output voltage with respect to input voltage shown in ES-6170.

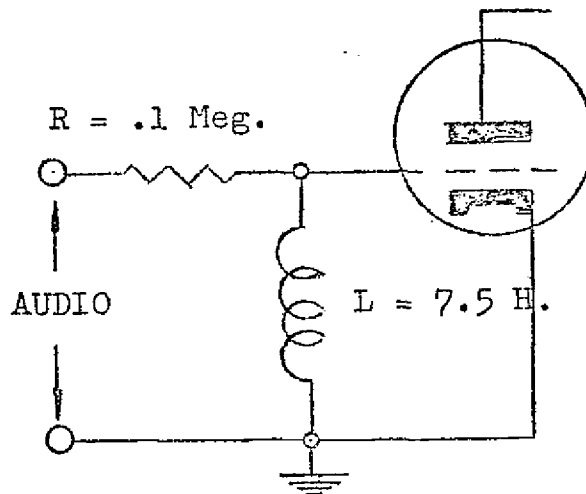

A. Pre-Emphasis
(Transmitter)

Time Constant =
 $L/R = 7.5 =$
75 microseconds.

Fig. 13

De-emphasis at the receiver must be the reverse of the pre-emphasis characteristic. This is accomplished by making the time constant of the resistor and capacitor in Fig. 14 equal to that of the pre-emphasis circuit. Since capacitive reactance decreases with increased frequency, the voltage across it decreases as the frequency rises. When the proper time constant is chosen the higher frequencies are restored to their normal values. If the capacitor is in microfarads and resistance is given in ohms, the product of R times C gives the time constant in microseconds. For example, in Fig. 14; the capacitor is .001 microfarad and the resistance is 75,000 ohms. The time constant, therefore, equals R times C equals 75,000 times .001 equals 75 microseconds. This is the same time constant as that of the inductor and resistor in Fig. 13. Looking at ES-6170 upside down the reading frequency from right to left will give the response of this combination.

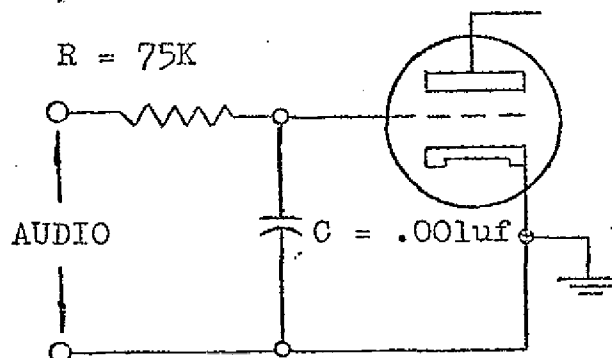

B. De-Emphasis
(Receiver)

Time Constant = $R \times C =$
 $75,000 \times .001 =$
75 microseconds.

Fig. 14

To clarify the need for pre-emphasis in an FM transmitter, three important reasons are listed as follows:

1. Most offending noise appears to be in a frequency range of between 5 and 15 kC.
2. Given two noises of equal amplitude, the one of higher frequency will cause greatest phase shift of the carrier and thus appear greater in amplitude at the output of the FM receiver. (This can be somewhat verified by listening to the high pitched hiss in an FM receiver when the carrier is unmodulated. Much of this is due to thermal noise within the receiver.)
3. In normal programming, little energy content is present at the higher frequencies.

In almost all standard broadcast transmitters the modulator circuit of the transmitter is arranged so that the frequency deviation, due to modulation is directly dependent upon the amplitude of the modulating signal and not upon the frequency. This is true of all Gates FM broadcast transmitters. Therefore, whether or not frequency response of the transmitter is to be flat or have pre-emphasis is left to the audio section of the transmitter. Actually, the audio section of Gates FM transmitters are designed to have a flat response from 50 to 15,000 cycles. Response of the audio system and of the transmitter as a whole is then regulated by a plug-in unit which is connected just ahead of the audio input transformer. Input impedance at this point is usually 600 ohms. A-31143 is a schematic diagram of two types of plug-in units. Diagram A is that of a flat pad with an insertion loss of approximately 17.5 dB at any audio frequency. Diagram B is that of a pre-emphasis unit. Insertion loss at 400 cycles is approximately 17.5 dB or the same as that of the flat pad shown in diagram A. At 15,000 cycles insertion loss of diagram B is almost zero. Circled numbers on the schematic of A-31143 represent connections to the octal plug-in unit of the Gates transmitter.

It has become fairly standard practice throughout the FM broadcast industry to use +10 dBm as an input level for modulating the FM broadcast transmitter 100%. If we are using the flat pad designated "A" on schematic A-31143, and feed an audio signal of approximately +10 dBm into the audio connections of the FM transmitter, we will modulate the transmitter approximately 100% as observed on an FM monitor. 100% modulation in the FM broadcast band is set as ± 75 kC swing. For other broadcast frequencies, different swings may be set as being 100% modulation. When using the flat pad ("A" of A-31143 schematic), it makes no difference what modulating frequency we put into the transmitter between 50 and 15,000 cycles. Frequency swing, or modulation percentage, will remain practically constant, give or take a decibel or so. If we are using the pre-emphasis pad schematic B of A-31143 and feed an input level of +10 dBm at 400 cycles into the audio input terminals of the FM transmitter, the monitor will again read approximately 100%

modulation. If we now raise the frequency of the modulating signal from 400 to 5,000 cycles and still want to modulate 100%, we must reduce the audio input level approximately 8 dB or to an input level of approximately +2 dBm. If we raise the audio input frequency to 15,000 cycles and still want to modulate 100%, we must reduce the audio input level still further to a level of approximately -7 dBm. If we don't do this the transmitter will over-modulate.

The FCC has ruled that all FM broadcast transmitters in the frequency range of 88 to 108 megacycles must be provided with this pre-emphasis. All standard FM receivers are then automatically provided with the standard 75 microsecond de-emphasis.

When using FM transmission as a means of communications or broadcasting in other frequency ranges, it must first be determined what response the overall system shall have. In many communications bands the frequency swing is restricted to very narrow limits. Also, to conserve bandwidth overall response is cut off above about 3,000 cycles and the low below 300 cycles. It would be of no value to use a pre-emphasis system at the transmitter which raised the higher frequencies (15,000 cycles) 17 dB above 400 cycles when the receiver was incapable of passing anything above 3,000 cycles. Conversely, if the audio response of the transmitter were flat from 0 to 15,000 cycles, and the receiver used de-emphasis, bass notes on any musical program would sound very boomy and bassy. High notes would hardly come through at all. It is, therefore, wise to check on the overall desired response of the entire system before deciding whether or not pre-emphasis at the transmitter is needed.

General

If the exciter has been properly tuned up, output power in the vicinity of 10 W. should be obtained. If trouble is experienced along the way in the tune-up procedure, the fault can usually be isolated by referring to typical test point voltages given on a following page.

There are five key test points that are indicative of proper operation.

About -35 volts should be obtained at TP104. This indicates that the pulse stages V101 through V104 are probably operating properly.

About -2 volts should be obtained at TP106. This indicates that V105 and associated circuitry is working okay.

Approximately .5 VRMS, R.F. voltage should be obtained at TP111 and/or TP112. This would indicate that frequency multiplier stages V105 through V109 are operating properly.

Around -7 volts should be obtained at TP116. This indicates sufficient driving power to final amplifier stage V113.

If a defect is suspected but can not be spotted, checking resistance of the various tuning coils L101 through L115 may locate the trouble.

The proper resistance value of these coils is listed below along with the condenser value for comparison purpose. The measured resistance should not deviate by more than about 20%. If the accuracy of the voltmeter is not known, a comparison between similar coils can be made. For example, the resistance of L101, L102 and L103 should be the same.

<u>COIL</u>	<u>DC RESISTANCE</u>	<u>CONDENSER VALUE ACROSS COIL</u>
L101,L102,L103	21 ohms	150 mmf.
L104,L105	9.6 ohms	100 mmf.
L106,L107	5.5 ohms	24 mmf.
L108,L109	2.1 ohms	24 mmf.
L110,L111	1 ohm	See Schematic
L112,L114,L115	.12 ohm	See Schematic
L113	.43 ohm	See Schematic

Considerable deviation of resistance from the above given values indicates either the wrong coil, shorted turns, open turns or a change in value of some other component connected across the coil.

The value of any other parts connected across the coils is to be considered insignificant when compared to the DC resistance of the coil.

Coupler Exciter to a Following Stage

It is preferred method that the final amplifier of the exciter be connected to an external dummy load of 51 ohms through a 51 ohm cable while tuning. Tuning the final amplifier in this manner is a good check on its proper operation.

When changing the RF output connection of the exciter from a dummy load to a following amplifier stage, an attempt should be made to get a proper match to 51 ohms at the input to the following amplifier stage.

If the output coupling control (C159) and plate tune (C158 on the exciter unit have to be considerably readjusted when coupled into a succeeding amplifier stage, a major mismatch of impedance is to be suspected at the input of the following amplifier stage. This will result in considerable loss of drive to the following stage and cause high standing waves to appear on the interconnecting coax between exciter and following stage.

Most of the amplifier stages that will be used following the M5534 exciter unit will not generally require the full 10 watts of driving power. A 50 watt amplifier stage will require about 2 watts of drive and a 250 watt amplifier about 4 watts of drive.

In no case should C158 plate tune or C159 output coupling be detuned to reduce output power. This is equivalent to operating V113 in an off resonant condition and would damage the tube eventually.

Output power can be reduced to almost zero by turning R155, output control to a counterclockwise position. This reduces screen voltage to V113 and consequently, the plate current which increases efficiency of V113.

In some cases, B+ voltage of 320 volts will be tapped off of TB101 terminal 6 to supply screen voltage to a following amplifier stage. The external +320 should not exceed a drain of about 30 ma. for continuous operation.

Reducing screen voltage of V113 by adjustment of R155 will drop V113 current drain from about 60 ma. for 10 watt output to about 25 ma. for 2 watt output. This "extra" current may then be used for external purposes.

In summary, when driving an additional amplifier stage from the exciter unit, reduce output by adjustment of R155 and keep C158 and C159 tuned for maximum grid drive in the following stage.

V113 Efficiency

An external jumper is provided on TB101 terminals 5 and 6. An ammeter may be connected in series with this jumper to measure V113 plate current.

B+ voltage has been previously set at +320. Power input to the plate circuit of V113 may be calculated from the ammeter and voltage readings. The voltage drop across R153 must first be calculated. This resistor is in the cathode circuit of V113. Its value is 250 ohms.

The formula to use would then read:

$$\text{Power input to plate circuit V113} = I_p \times (E_p - (IR))$$

where IR is drop across R153

If, for example, the ammeter reading obtained when connected in series with TB101-5 and 6 was 60 ma. and B+ to ground was +320:

$$\begin{aligned}\text{Power input V113} &= .06 \times (320 - (.06 \times 250)) \\ &= .06 \times (320 - 15) \\ &= .06 \times 305 \\ &= 18.3 \text{ watts}\end{aligned}$$

Assuming an output power of 10 watts:

$$\begin{aligned}\text{Plate dissipation V113} &= \text{Power input} - \text{Power output} \\ &= 18.3 - 10 \\ &= 8.3 \text{ watts}\end{aligned}$$

$$\begin{aligned}\text{Efficiency of V113 Stage} &= \frac{\text{Power Output}}{\text{Power Input}} \\ &= \frac{10}{18.3} \\ &= 54.8\%\end{aligned}$$

The above figures can be considered typical. If the output power is not known, an efficiency factor of 55% should be assumed.

TYPICAL DC TEST POINT
 VOLTAGES OF M5534 EXCITER UNIT.
 NO MODULATION. MEASURED WITH
 20,000 OHMS/VOLT VOLTMETER.

	WITH DRIVE	NO DRIVE
	<u>VOLTS</u>	<u>VOLTS</u>
TP101	-.3 to -2.5	1 to 2
TP102	-2 to -3.5	.5 to 1
TP103	9 to 13	3 to 6
TP104	-34 to -39	0
TP105	65 to 75	25 to 35
TP106	-1.5 to -2.5	0
TP107	54 to 58	30 to 40
TP108	72 to 76	23 to 28
TP109	65 to 80	35 to 45
TP110	122 to 132	195 to 205
TP111	0 DC (.4 to .6 V. RMS RF)	0
TP112	0 DC (.4 to .6 V. RMS RF)	0
TP113	110 to 120	170 to 180
TP114	120 to 140	220 to 230
TP115	190 to 210	245 to 255
*TP116	-5 to -10	0
*TP117	150 to 170	195 to 205
TP118	13 to 17	7 to 10
TP119	320	320

*Readings for TP116 and TP117 obtained with R167, output control full clockwise or maximum output position.

PROOF OF PERFORMANCE

Center Frequency, Noise, Distortion, Response.

Proof of performance data as made by the Gates Radio Company on FM transmitters can be likened to listening to the transmitter on a high quality receiver. This tends to "prove-out" the transmitter since measuring and listening equipment is completely external to the transmitter proper and the RF signal is taken from "off-the-air".

Instead of a receiver, an FM monitor of good quality and FCC approved is used. Reference to drawing A-4165 will show the general test set up for making proof of performance measurements.

First off, a sample of the transmitted RF is coupled to the modulation and frequency monitor. This is taken from the antenna, transmission line or from the PA chamber. The method used is determined somewhat by the amount of power needed by the monitor (usually about 1 watt) and by the output power of the transmitter. For low power FM transmitters up to perhaps 250 watts, a sample of RF may be taken by "tapping" off of the output transmission line with a variable condenser in series with the coaxial line going to the monitor. This has the disadvantage though of introducing a slight mismatch back into the transmitter. Usually, it is impossible to obtain enough power to drive the monitor from the antenna without introducing another amplifier ahead of the monitor to raise the received signal up to the necessary level. In higher powered transmitters, a monitor loop is usually coupled to the final amplifier section to sample a portion of the transmitted output.

A good quality audio oscillator of 600 ohms output impedance is then connected to the audio input terminals. These are TB101-1,2, 3, on the exciter unit with terminal #3 being ground. Output level requirements are at least +10 dBm. Since the exciter itself is capable of generating a frequency modulated carrier with distortion ranging as low as .2% the audio oscillator must be in good working order.

A distortion analyzer or meter is connected to the audio output terminals of the monitor. An oscilloscope while being an optional item in making measurements is very helpful in tracing any possible difficulty.

The complete method used to adjust the exciter for proper response, distortion noise and etc., will now be given as it is done at the Gates factory. Proper proof of performance adjustments as the factory are made only after complete tune-up has been done. After the customer receives the unit, any part of the measurements may be made without undue effect upon other measurements.

All proof of performance measurements should be made with shield covers in place.

5/26/58

-27-

M5534/M5672/M5673

Setting Carrier Frequency

It is desirable to first set the exciter unit to proper carrier frequency. This should be done first, not only because it is desirable to have the unit on proper frequency, but if the carrier is several thousand cycles off center, undesirable beats may occur within the monitor. This will cause high noise readings and may effect apparent frequency response.

Usually, all that is required to place the exciter unit on proper center frequency is to sample a portion of the RF output with a good frequency standard and adjust C102 (frequency adjust control) until the frequency standard shows proper frequency.

Occasionally, a crystal may be used that cannot be set exactly to center frequency by means of C102 alone. Also, a crystal that was originally on proper center frequency, may drift off the range of C102 due to aging. When this happens, additional frequency adjustments may be made by varying the value of C103. This condenser controls the amount of feedback to the crystal. Increasing the value of C103 lowers the carrier frequency and decreasing the value of C103 raises the crystal frequency.

With the value of C103 set at the optimum value of 150 mmf. varying C102 (frequency adjustment control) from minimum to maximum will cause the carrier frequency to vary approximately 30,000 cycles. Changing the value of C103 from 150 mmf. to 50 mmf. will raise carrier frequency about 10,000 cycles. Changing C103 from 150 mmf. to 250 mmf. will lower carrier frequency about 3,000 cycles.

Distortion Measurements and Adjustments

After the exciter unit has been properly set to carrier frequency, distortion adjustments are made. Set the audio oscillator to modulate the exciter 100% at 50 cycles. Adjust R119 for minimum distortion. Note: If R119 is considerably away from the proper adjustment point, it may be impossible to obtain 100% modulation or the waveform obtained may be completely "torn up". If such is the case, adjust R119 for minimum distortion while modulating somewhat less than 100%, say about 50%. Then bring modulation back up to 100% and readjust R119 for minimum distortion as observed on the distortion analyzer. Next, adjust C110 for minimum distortion. Then readjust R119 for minimum distortion.

Adjusting C110 effects the percentage of modulation level as observed on the monitor. Final adjustment of C110 should be done as follows: Distortion should first be reasonable, say better than 1-1/2% at 50 cycles. Then commence adjusting C110 for minimum distortion while at the same time keeping the percentage of modulation set to 100% as observed on the monitor. This adjustment is not critical but a point will be found where the distortion "dips".

After this dip has been reached, readjust R119 for minimum distortion. The distortion figure should be 1% at 50 cycles.

If it is impossible to reduce distortion at 50 cycles, it is advisable to check just the audio portion of the exciter unit and or the audio oscillator itself. The audio portion of the exciter consisting of tubes V114 and V115 may be checked by running test leads from TP118 and TP120/121 to the input of the distortion analyzer. Distortion as measured at TP118 should be well below .5% at any audio frequency. If distortion from the audio section is O.K. but overall distortion as measured from the monitor is not, then waveforms of the pulse circuitry should be checked. Typical waveforms of V101 through V104 are given on drawing B-65626.

One hundred percent modulation should occur at an input level of approximately +10 dBm from 50 to 1000 cycles. This input level will cause an RMS audio voltage at TP118 of about 30 volts. If an input level of +10 dBm does not generate an RMS voltage of about 30 volts at TP118 then a defect in the audio section may be suspected. If sufficient RMS voltage exists at TP118, and the exciter will not modulate 100%, then a defect in the modulator or previous stage should be suspected.

If any FM system, worst distortion occurs at the lowest modulating frequency, in other words, if distortion is .5% at 50 cycles, then distortion can be expected to be better at all higher modulating frequencies. Occasionally, a higher distortion figure may result between 10,000 and 15,000 cycles. The fault will not generally lie in the modulator stage, however. It could lie in the audio section.

If higher distortion is present at the higher modulating frequencies only, it can usually be traced to one of three causes.

1. High FM or AM noise.
2. Insufficient bandwidth in frequency multiplier stages.
3. Frequency and modulation monitor not correctly tuned to carrier frequency.

A standard monitor contains de-emphasis circuitry that causes lower modulating frequencies of 50 to 1000 cycles to "come out" of the monitor with an apparent advantage of around 15 to 17 dB over audio that is recovered at 15,000 cycles. If noise is down only 40 to 50 dB with respect to 100% modulation at 400 cycles, it will usually not prevent a good distortion reading at a low modulating frequency. However, if frequencies between 10,000 and 15,000 cycles are 15 dB lower in amplitude than 400 cycles, the noise with respect to these frequencies will only be about 30 dB down. This would correspond to the 3% distortion range on a distortion analyzer. A quick check to determine whether noise is causing an apparent high distortion reading is to remove all modulation from the input to the exciter or transmitter. If the

distortion meter needle does not drop appreciably, a noise measurement should be made on the exciter.

If bandwidth is insufficient in frequency multiplier stages, some of the higher frequency sidebands will be clipped causing undue distortion. A complete re-tune up is recommended.

Mis-tuning of the monitor will also cause some clipping of sidebands at higher frequencies. In addition, beat frequencies may be present that show up as noise and prevent a good distortion reading.

Once set, distortion controls R119 and C110 may not have to be re-set for the life of the exciter unit. Changing modulator tubes will probably not cause distortion figures to change by more than .1 or .2%. There are exceptions to every rule though.

Overall Audio Frequency Response

If the exciter unit is used in the FM broadcast band of 88 to 108 Mc or as the aural exciter unit for TV transmitters, overall audio frequency response should follow the 75 microsecond curve shown on drawing ES-6170. In other frequency ranges it may be desirable to have the overall frequency response flat.

Several methods of making frequency response measurements using an FM monitor are available. Two will be described. Simplest is to set the audio frequency at about mid-range, say 5,000 cycles, and modulate the exciter the proper amount. In this case, the proper modulation level would be 35%. Keeping the input audio level constant, the frequency may then be adjusted upward to 15,000 cycles and then downward to 50 cycles. Using this method, the response will seldom rise above the curve and makes it easy to calculate the percent or decibel error. For example, if at 15,000 cycles modulation the modulation monitor reads only 80% modulation, it can be quickly seen from drawing ES-6170 that the response is -2dB below the normal curve. The same reasoning may be applied to the low end of the curve. If the input attenuator is calibrated in small steps, it is also possible to determine the amount that the input audio has to be increased to bring the monitor up to the required percentage of modulation at any modulating frequency.

Another method of measuring frequency response involves keeping the percent of modulation constant as read on the monitor. To use this method, the audio oscillator output must be accurately calibrated. To start with, the carrier should be modulated 100% at 400 cycles. Changing the audio frequency from about 50 cycles to 400 cycles should not change the percentage of modulation appreciably, if the modulating frequency is raised upward, say to 5000 cycles, the input level must be reduced to keep the percent modulation at 100%. For 5000 cycles, the amount of reduction should be 8.2 dB. For 15,000 cycles the amount of reduction of input level should be 16.9 dB.

Recording the amount of reduction of input level versus modulating frequency and reversing the sign of polarity will give the rise in frequency response. This can then be compared to the curve of drawing ES-6170.

The second suggested method is particularly useful when response measurements are being made at 25 and 50% modulation levels or when a standard FM monitor is being used to measure response of an exciter being used to generate the aural carrier for a TV transmitter where a normal 100% modulation is ± 25 kC. This will correspond to 33-1/3% modulation on a standard FM monitor for the FM broadcast band of 88 to 108 mC.

Seldom will any difficulty be encountered in coming close to the standard 75 microsecond curve between 400 and 10,000 cycles. Generally, if troubles develop with response it will show up as being 2 or 3 dB down at 50 cycles and/or down the same amount at 15,000 cycles. Frequency compensating condensers have been incorporated in the audio amplifier section to take care of just such a contingency. C163 will affect low frequency response between 50 and 100 cycles. For each .01 mfd. that C163 is reduced, the response at 50 cycles will rise approximately 1 dB. C160 affects response between 10,000 and 15,000 cycles. Changing the value of C160 from 50 to 200 mmf. will raise the audio response as measured at TP118 about 3 dB at 15,000 cycles.

Audio response as observed at TP118 will usually have to be compensated high about 2 dB at 50 cycles and at 15,000 cycles, to obtain an ideal overall response curve.

Stagger tuning L103 will also help response at 15,000 cycles a dB or so. When this is done, a voltmeter should be connected to TP106 and the amount of staggering of L103 should not reduce the negative voltage observed by more than .5 volt.

FM Noise

FM noise is measured with respect to 100% modulation at 400 cycles. To make this measurement, modulate the exciter 100% at 400 cycles and set a reference level on the distortion analyzer. Remove all modulation and read the FM noise on the appropriate scale. FM noise of the exciter unit can be expected to approach 70 dB or better.

If FM noise is high, the audio section is the most logical place to start looking. Removal of the last audio tube V115 is a quick way of checking if the trouble is in the audio. The next best bet is the power supply. Hum and noise voltage of the power supply should be between 85 and 90 dB down with respect to +320 volts DC. If these two places fail to show any defect, the noise is probably originating from and including the crystal through the modulator stage V104. Stages after V104 are unlikely to cause FM noise.

AM Noise

AM noise is measured or referenced with respect to a 100%

amplitude modulated wave. This AM noise usually consists of 60 or 120 cycle hum superimposed upon the carrier. There are several ways of making this measurement. Some FM monitors have a provision for making this measurement. This measurement should be made with no modulation present.

AM noise as measured from the exciter unit is usually so low as to be difficult to even measure. It will generally be better than 70 dB. If AM noise is high, it can actually originate in most any stage. However, if upon analyzing the type of noise it is found to have a basic 120 cycle component, the power supply should be suspected. If the noise appears to be mostly a 60 cycle component, a heater to cathode leak in any stage should be suspected. A loose connection in any stage will cause the AM noise to rise when the exciter unit or cabinet is jarred. A point often overlooked in making AM noise measurements is the sampling loop or device. For example, if the RF sampling loop is mounted in a PA chamber where blower vibration is apt to occur, this vibration will show up as high AM noise if the sampling loop is not securely mounted.

Typical Proof of Performance Readings

If the exciter unit has been shipped as an individual unit, the complete test data sheet will probably have been filled out and included within this section. If the exciter unit is part of a higher power transmitter, the test data sheet is included with the overall instruction book. A set of typical readings for proof of performance is given below:

Carrier frequency, OK

Distortion at 100% modulation:

Response with reference to standard 75 micro-second pre-emphasis curve.

50 Cycles	.32	1 dB
100 Cycles	.28	-.3 dB
400 Cycles	.25	0
1000 Cycles	.25	0
2500 Cycles	.24	0
5000 Cycles	.20	0
7500 Cycles	.23	-.4 dB
10,000 Cycles	.36	-.2 dB
15,000 Cycles	.68	-1 dB
FM Noise:	-69		dB
AM Noise:	Better than		-70 dB

MAINTENANCE

Since moving parts are at a minimum in the exciter unit, routine maintenance is a simple procedure. The few moving parts that are used such as variable condensers, potentiometers and variable inductors will, perhaps, stay set in one position for the life of the exciter unit. The one exception to this would be C102 the frequency adjust control.

Because routine maintenance is used to prevent trouble and not start it, it is not deemed advisable to poke and pull at every component part at a pre-arranged time. Tubes are the most likely component to go bad. A routine testing of all of the tubes at least once every six months is recommended.

One of the best ways to foretell trouble is by test point voltages. These are recorded on the factory test data sheet. When the exciter unit is first received and placed into operation, it is advisable to go over these test point voltages and record the reading obtained. The test point voltages should then be checked weekly or monthly. A substantial variation from the original recorded value would indicate a failing tube or other component in that circuit. These voltage measurements should always be made with the same meter since a normal 10% variation from one meter to the next may be expected.

An occasional check on the noise, distortion and response with a test setup such as shown in drawing A-4165 will possibly reveal an eminent failure of one of the audio stages or one of the pulse stages V101 through V104.

When tubes are checked and replaced, it is wise to replace them in their original socket. If V111, V112 or V113 are changed, it may be necessary to retune associated circuitry for best performance.

TROUBLESHOOTING

It would be impossible to list every failure and possible cure that might occur in the exciter unit. The same thing may be said of any other piece of electronic gear. However, 90 to 95% of all failures can perhaps be predicted with a few possible clues listed that may help in locating the defect.

Failures or difficulties that may occur in the exciter unit can be divided into two broad categories.

1. Problems associated with carrier only.
2. Problems associated with modulation of carrier.

Problems associated with carrier only can be sub-divided into several groups.

- A. No carrier (no power output).
- B. Low carrier (power output low).
- C. Intermittent Carrier.
- D. Oscillation.
- E. Carrier off frequency.

Problems associated with carrier only will now be discussed and some possible remedies and troubleshooting hints suggested.

A. No Carrier

Of the many problems that can occur, this perhaps is the most serious and yet the easiest defect to find. When this happens, a tube has usually gone completely dead. A comparison of test point voltages with those given at the end of the complete tune up procedure, test data sheet or voltages recorded at test points when the unit was working properly should reveal the defective stage. The difference in test point voltages with an without drive is in most cases quite pronounced. When a tube has gone completely sour or dead, voltages noted at test points located in the plate circuit of that particular tube will rise up to the full plate voltage of +320 volts. If the tube is drawing excessive current, the voltage noted at the test point will be extremely low. A failure of any circuit from oscillator stage to power amplifier stage will, of course, cause loss of carrier. The power supply itself should not be overlooked.

To quickly isolate the trouble to a single general area, the following process could be followed:

1. Check to see if B+ voltage exists at TP119.
2. Check negative voltage at TP104. A reading of about -35 volts here indicates V101 through V104 are operating properly.
3. Check negative voltage at TP106. A negative reading here from -2 to -3 volts indicates that the grid of V106 is receiving drive from previous stages.
4. Check RF voltage at TP111 and/or TP112. An RF voltage here of about .5 volts RMS indicates that there is sufficient drive up to this point.
5. Check negative grid voltage of V113 at TP116. A reading of at least -5 volts here indicates plenty of drive and that the grid circuit of V113 is operating.

Should all of the suggested methods fail to locate the trouble, a more thorough check will have to be made. Reference to voltages listed on schematic diagram C-78064 and to waveform measurements on diagrams B-65625 and B-65626, in the back of the book, may help. Approximate RF voltage measurements are also included at the end of this section.

B. Low Carrier

The same general routine used to track down the stage causing a carrier failure can be used to check for a low carrier. Tracing down the fault for a low carrier can be more elusive though because voltages will not deviate as much from normal. Low carrier levels are usually caused by a tube with low emission. A slight mistuning somewhere along the frequency multiplier chain can cause low output. Reference to the RF voltage chart at the end of this section may be of additional help.

C. Intermittent Carrier

An intermittent carrier can be very difficult to track down because about the time test equipment is set up to find the trouble, it disappears. A recommended method of finding this is to start at the final stage V113 and place a meter probe into TP117. Then tap on the chassis or whatever else it takes to cause the intermittent condition. Working back toward the crystal from stage to stage and test point to test point; a point should be reached where a test point voltage does not vary as the intermittent condition is caused to occur. This should be the last properly operating stage. It should be expected that the failure is occurring in the stage immediately following the point where the test point voltage is not varying.

An intermittent carrier can be caused by most anything. A bad tube, condenser, resistor or loose connection or an intermittent short.

D. Oscillation

It is an almost unheard of condition for a frequency multiplier stage to oscillate since frequencies found in the grid circuit are different from frequencies found in the plate circuit. It is within the realm of possibility, however. If an oscillation should occur, it will probably be traced to the final amplifier stage V113. This stage is self-neutralizing and will probably not cause any trouble as long as the shields over the coils are tightly in place and all connections are tight.

A condition somewhat akin to oscillation has been noted while using pulse circuitry similar to that in this exciter unit. A leaky condenser or intermittent connection in the pulse circuitry can cause multiplier stages to "fire" off at their resonant frequency. This oscillation will be damped and only occurs momentarily but may be aggravating.

E. Carrier Off Frequency

When the carrier is consistently too far removed from proper center frequency, the trouble can be traced directly to the oscillator stage. This could be due to the oven thermostat sticking and causing the crystal to overheat or could be due to the oven not heating at all. If the thermostat is sticking, pilot lamp A101 will be on all the time provided it is not burned out. If the oven is not heating at all, the pilot lamp should not light.

Some crystals will age and drift off frequency after a length of time. Replacement of the crystal is the only solution here. A change of value of almost any component in the oscillator stage V101 could also cause the carrier frequency to deviate.

Problems associated with modulation of the carrier will now be discussed and some possible remedies and troubleshooting hints suggested. Under this category, sub-divisions might be as follows:

- A. High Distortion.
- B. Improper Frequency Response.
- C. Will Not Modulate At All.
- D. High FM Noise.
- E. High AM Noise.

When it is known that any of the above listed faults exist, it will save time to first isolate the trouble to either the audio stage or the rest of the exciter unit. It is easy to check the output of the audio stages by connecting a ground lead from a black testpoint and a "hot" lead from TP118. These two leads can then be run to the input of a distortion analyzer. If these leads are very long, they should be shielded or they may pick up external hum and noise.

A. High Distortion

When high distortion is present, it can usually be divided into three categories.

1. Distortion high throughout the audio spectrum of 50 to 15,000 cycles.
2. Distortion high at low frequencies only.
3. Distortion high at high frequencies only.

When distortion is high throughout the audio spectrum of 50 to 15,000 cycles, the fault is apt to lie in the audio stages of V114 or V115. It is wise to check these stages anyway when modulation difficulties are experienced. A failure of any component in the audio stages could cause the distortion to rise. Checking voltages against the schematic should show the difficulty. Changing a tube will usually cure the trouble.

It is characteristic of an FM system that the greatest difficulty in attempting to modulate occurs at low frequencies. When the overall distortion is high between 50 and 400 cycles only, the trouble will usually be found in the modulator stage V104 or in the pulse circuitry just preceding it in stages V101 through V103. A check of the waveforms in stages V101 through V104 is advisable. These can be checked against drawing B-65626. These waveforms were made with a calibrated scope type 524AD Textronix. If a calibrated scope is not available, an ordinary scope may be calibrated approximately by the following method: Peak to peak waveforms are always 2.8 times the RMS value of a sine wave. The hot scope lead can be connected to a "hot" filament wire which should have an AC voltage present of about 6.3 VAC. The peak-to-peak value would then be 17 or 18 volts. The scope can then be calibrated accordingly by setting a reference point on the scope screen.

The most important waveform to check is that at TP103. With V104 removed from its socket, the waveform here should be a good sawtooth with an amplitude of 25 to 30 PP volts. The leading edge should be linear with no rounding off. When V104 is inserted and the bias properly set, the waveform will be "cut" approximately in the middle horizontally.

When distortion occurs only between 10,000 and 15,000 cycles it is normally due to high noise or a clipping of sidebands in some tuned stage. The FM noise can be quickly checked. It should be somewhere in the vicinity of -60 dB to assure that noise is not masking out a good distortion reading. The monitor should be checked for proper tune-up. Improper tune-up of the first two or three frequency multiplier stages will cause a high distortion reading at high audio frequencies. If touching up the tuning slightly of L101 through L107 decreases the distortion, a complete retune up of L101 through L107 is indicated. L101, L102 and L103 are most likely to clip sidebands and cause high distortion at 15,000 cycles.

B. Improper Frequency Response

If frequency response is not correct the audio section should again be checked for proper response. The frequency response as noted at TP118 should approximate the desired overall frequency response. It usually will be 2 dB or so high at both extremes of the audio spectrum.

Should the frequency response noted at TP118 prove to be okay, but overall frequency response be down at 15,000 cycles, it will usually be caused by too narrow a bandwidth or mis-tuning of some of the low frequency multiplier stages L101 through L107. L101 through L103 are most apt to cause this difficulty. Improper tuning of the modulation and frequency monitor can also affect apparent frequency response.

A change in the components associated with modulator stage V104 can cause poor low frequency response. This is especially true of C112, R118 and R117 or R119.

C. Will Not Modulate at All

This condition will probably resolve down to a dead audio stage. However, if audio is present at TP118 and the carrier cannot be modulated, it is likely that C112 has developed a short. It is possible in some cases for V104 to be dead and still pass a carrier through due to the tube capacity. In such a case, modulation could not occur.

D. FM Noise

If FM noise exists, the audio stages can be quickly eliminated by pulling V115 from its socket. Noise in the audio stage can be caused by a heater-cathode leak or a filament wire lying near a grid connection. Hum from the power supply or improper regulation of the power supply can cause noise in the audio stages.

If the noise is not located in the audio stages, the next most probable suspect is the pulse stages of V101 through V104. Any amplitude variation in these stages will cause a "frequency modulated" noise component. This could be caused by a heater-cathode leak or failure of a stage to properly limit. Hum from the power supply could also cause this difficulty. Modulation at a 60 cycle rate can also be caused in the crystal circuit by induction from the crystal heater.

E. AM Noise

AM noise is one fault that will not usually be traced to the audio stages because an amplitude variation in the audio stages causes an FM noise component to appear. While this type of difficulty can occur in most any stage except the audio stages, it is most apt to prevail in one of the frequency multiplier stages and usually near the higher frequency end of the multiplier chain. Hum in B+ coming from the power supply, heater cathode leakage or an intermittent connection can cause this defect. Hum from heater cathode leakage will show itself as a 60 cycle component and power supply hum as a 120 cycle component.

Typical RF Voltage Measurements.

The following RF voltage measurements were made using an H-P Model 410B VTVM. The AC probe (RF) was utilized in all cases. Also the probe was utilized in all cases. Also, the probe was placed into the circuit under test and that particular circuit then retuned for resonance. Frequency of the exciter unit was 88.1 mc. It may be impossible to obtain these readings at the high end of the band if capacity or inductance can not be reduced a sufficient amount to obtain resonance when the probe is placed in the circuit.

All values are RMS.

<u>Location</u>	<u>Reading</u>
Pin 5, V105	13.5 V.
Junction C118, C119, L102	8.2 V.
Pin 1, V106	6 V.
Pin 5, V106	18 V.
Pin 1, V107	5.2 V.
Pin 5, V107	29 V.
Pin 1, V108	4.7 V.
Pin 5, V108	29 V.
Pin 1, V109	6.6 V.
Pin 5, V109	34 V.
J101, TP111	.47 V.
J102, TP112	.51 V.
Pin 5, V110	6.2 V.
Pin 6, V110	6.4 V.
Pin 1 & 2, V110	21 V.
Pin 5, V111	9 V.
Pin 6, V111	10.5 V.

<u>Location</u>	<u>Readings</u>
Pin 1 & 2, V111	23 V.
Pin 5, V112	9 V.
Pin 6, V112.	9.5 V.
Pin 1 & 2, V112	26 V.
Pin 1 & 3, V113	19 V.
Pin 6 & 8, V113	150 V.

5/26/68

-40-

M5534

M5534 STEREO EXCITER

PARTS LIST

<u>Symbol No.</u>	<u>Gates Part No.</u>	<u>Description</u>
A101	396 0045 000	Lamp, 6-8 V. #47
AT101	932 0016 001	Std. 75 microsecond pre-emphasis pad
C101,C104,C108, C161,C163, C162,C176	506 0014 000	Cap., .1 mfd, 400 (W)V. DC
C102	520 0301 000	Cap., Vari. 4.5 to 100 mmfd., shaft type
C103	516 0193 000	Cap., .00015 mfd, ±10%, 600(W)V. ceramic tubular
C105	516 0185 000	Cap., .00005 mfd, ±10%, 600(W)V. ceramic tubular
C106,C115,C116, C117,C120,C121, C122	516 0082 000	Cap., .01 mfd., 1 kV.
C107,C123,C125, C126,C127,C129, C130,C131,C134	516 0074 000	Cap., .005 mfd, ±20%, 1 kV, ceramic disc
C109	506 0012 000	Cap., .03 mfd, 400(W)V. DC
C110	520 0125 000	Cap., Vari. 4.5 to 100 mmfd.
C111	516 0191 000	Cap., .0001 mfd, ±10%, 600(W)V. ceramic tubular
C112,C164	506 0017 000	Cap., 1 mfd, 400 (W)V. DC
C113,C118,C119	516 0175 000	Cap., .000015 mfd, ±10%, 600(W)V. ceramic tubular
C114,C135,C136, C142,C143,C145, C175	516 0054 000	Cap., .0001 mfd, ±20%, 1 kV ceramic disc
C124,C146	516 0172 000	Cap., .000005 mfd, ±10%, 600(W)V. ceramic tubular
C132	516 0345 000	Cap., .5 mmfd, 600(W)V. ceramic
C128	502 0183 000	Cap., 1 mmfd, ±.5 mmfd, 500(W)V. silver mica
C137,C144	516 0173 000	Cap., .0001 mfd, ±10%, 600(W)V. ceramic tubular
C138,C140	516 0252 000	Cap., .00033 mfd, ±10%, 600(W)V. ceramic tubular
C139,C141	516 0179 000	Cap., .000025 mfd, ±10%, 600(W)V. ceramic tubular
C147,C148,C149, C150,C151,C153, C155,C156,C157	516 0043 000	Cap., 470 mmfd, ±20%, 1 kV ceramic disc
C152,C159	520 0112 000	Cap., Vari. 2.7 to 19.6 mmfd.
C154,C158	520 0169 000	Cap., Vari. 2.4 to 10.8 mmfd. (butterfly type)

2/9/62

-1-

M5534 Stereo Exciter

<u>Symbol No.</u>	<u>Gates Part No.</u>	<u>Description</u>
C160	518 0039 000	Cap., Trimmer, 50-380 uuf.
C165,C166	524 0013 000	Cap., Filter 30/30 mfd. @ 525(W)V. DC
C167	522 0133 000	Cap., Filter 16 mfd, 450 (W)V.
C168,C169,C170, C171,C172,C173	516 0250 000	Cap., 500 mmfd, $\pm 20\%$, 500 V. DC ceramic (button type)
C174	516 0227 000	Cap., 500 mmfd, $\pm 20\%$, 500 (W)V. DC ceramic feedthru type
C177	506 0016 000	Cap., .5 mfd, 400 (W)V. DC
F101	398 0079 000	Fuse, 1½ amp, 3 AG Slo-Blo
F102	398 0006 000	Fuse, 1/8 amp, 3 AG
HR101	558 0001 000	Crystal Oven w/internal octal socket, 6.3 V. heater for operation at 60°C.
J101,J102	612 0237 000	Receptacle, UG-290A/U
J104	612 0369 000	Phone Jack
L101	913 1104 001	Freq. Multiplier Coil Assembly
L102,L103	913 1105 001	Freq. Multiplier Coil Assembly
L104	913 1106 001	Freq. Multiplier Coil Assembly
L105	913 1107 000	Freq. Multiplier Coil Assembly
L106,L107	913 1108 001	Freq. Multiplier Coil Assembly
L108,L109	913 1109 001	Freq. Multiplier Coil Assembly
L110,L111	913 1110 001	Freq. Multiplier Coil Assembly
L112,L115	492 0025 000	Coil, 2 to 3.7 uh.
L113	492 0027 000	Coil, 3.4 to 7 uh.
L114	492 0024 000	Coil, Vari. w/ brass slug
L116	913 1112 001	6J6 Plate Coil
L117	913 1113 001	Grid Coil for V113
L118	913 1114 001	Plate Coil for V113
L119		Output Coupling Coil for V113
L120	494 0110 000	R. F. Choke, 3.3 uh.
L122,L123,L126, L127,L128	494 0004 000	R. F. Choke
L121	476 0013 000	Choke, 6 hy. @ 160 ma, 165 ohms
L124,L125	913 1116 001	Isolation Choke for AC Line
P101,P102	610 0238 000	Plug, UG-88/U
P103	620 0122 000	Adapter, right angle
R101,R165,R166	540 0218 000	Res., 2.2 megohm, ½ W, 10%
R102,R113,R118, R122,R125,R129, R133,R144	540 0186 000	Res., 4700 ohm, ½ W, 10%
R103,R124,R104, R109,R112,R139, R158,R159,R164, R175	540 0202 000	Res., 100K ohm, ½ W, 10%

2/9/62

-2-

M5534 Stereo Exciter

<u>Symbol No.</u>	<u>Gates Part No.</u>	<u>Description</u>
R105,R152,R168	540 0190 000	Res., 10k ohm, ½ W, 10%
R106,R114	540 0207 000	Res., 270k ohm, ½ W, 10%
R107,R115	540 0762 000	Res., 68k ohm, 2 W, 10%
R108	540 0180 000	Res., 1500 ohm, ½ W, 10%
R110	540 0182 000	Res., 2200 ohm, ½ W, 10%
R111,R121,R128, R132,R136,R138, R141,R142,R145, R146,R149,R150, R162,R163	540 0206 000	Res., 220k ohm, ½ W, 10%
R116	540 0208 000	Res., 330k ohm, ½ W, 10%
R117	540 0198 000	Res., 47k ohm, ½ W, 10%
R119	550 0071 000	Pot., 50,000 ohm, linear
R123,R126,R127, R130,R120,R134, R135,R131	540 0210 000	Res., 470k ohm, 1/2 W, 10%
R137	540 0184 000	Res., 3300 ohm, 1/2 W, 10%
R140	540 0056 000	Res., 2k ohm, 1/2 W, 10%
R143,R147	540 0760 000	Res., 47k ohm, 2 W, 10%
R148	540 0178 000	Res., 1k ohm, ½ W, 10%
R151	540 0752 000	Res., 10k ohm, 2 W, 10%
R153	542 0064 000	Res., 250 ohm, 10 W.
R154	540 0166 000	Res., 100 ohm, ½ W, 10%
R155	550 0073 000	Pot., 100k ohm, linear
R156,R169	540 0756 000	Res., 22k ohm, 2 W, 10%
R157	540 0196 000	Res., 33k ohm, ½ W, 10%
R160	540 0189 000	Res., 8200 ohm, ½ W, 10%
R161	540 0183 000	Res., 2700 ohm, ½ W, 10%
R167	542 0095 000	Res., 10k ohm, 10 W.
R170	540 0478 000	Res., 6800 ohm, 1 W, 10%
R171	540 0213 000	Res., 820k ohm, ½ W, 10%
R172	540 0754 000	Res., 15k ohm, 2 W, 10%
R173	550 0067 000	Pot., 10k ohm, linear
R174	913 2346 001	Resistor Assembly, .1 ohm
S101	604 0005 000	Toggle Switch
T101	472 0088 000	Heater Transformer, Pri. 115 V, 50/60 Cycle, Sec. 6.3 V. C.T. @ 1.2 Amp.
T102	478 0144 000	Transformer, Audio Input
T103	472 0248 000	Transformer, Power
TB101	614 0054 000	Terminal Board

<u>Symbol No.</u>	<u>Gates Part No.</u>	<u>Description</u>
TP101,TP102, TP103,TP104, TP105,TP106, TP107,TP108, TP109,TP110, TP111,TP112, TP113,TP114, TP115,TP116, TP117,TP118		
TP119	612 0312 000	Test Point Jack
TP120,TP121	612 0311 000	Test Point Jack
V101,V105,V106, V107,V108,V109, V118	370 0040 000	Tube, 6AU6
V102,V103,V114	370 0116 000	Tube, ECC83/12AX7
V104	370 0112 000	Tube, 12AT7
V110,V111,V112	370 0082 000	Tube, 6J6
V113	370 0054 000	Tube, 6360
V115	370 0032 000	Tube, 6AQ5A
V116	370 0133 000	Tube, GZ34/5AR4
V117	370 0158 000	Tube, 6080
V119,V120	370 0001 000	Tube, 0A2
XA101	406 0057 000	Pilot Light Assembly, Clear
XAT1,(XC165, XC166)XV116, XV117	404 0068 000	Socket, Octal, Mica filled
XF101,XF102	402 0021 000	Fuseholder
XHR101	404 0053 000	Crystal Oven Socket
XV101,XV105, XV106,XV107, XV108,XV109, XV110,XV111, XV112,XV115, XV118,XV119, XV120	404 0038 000	Socket, 7 pin miniature, mica filled
XV102,XV103, XV104,XV113, XV114	404 0042 000	Socket, 9 pin noval, mica filled
Y101		Crystal in T9D Holder

2/9/62

-4-

M5534 Stereo Exciter

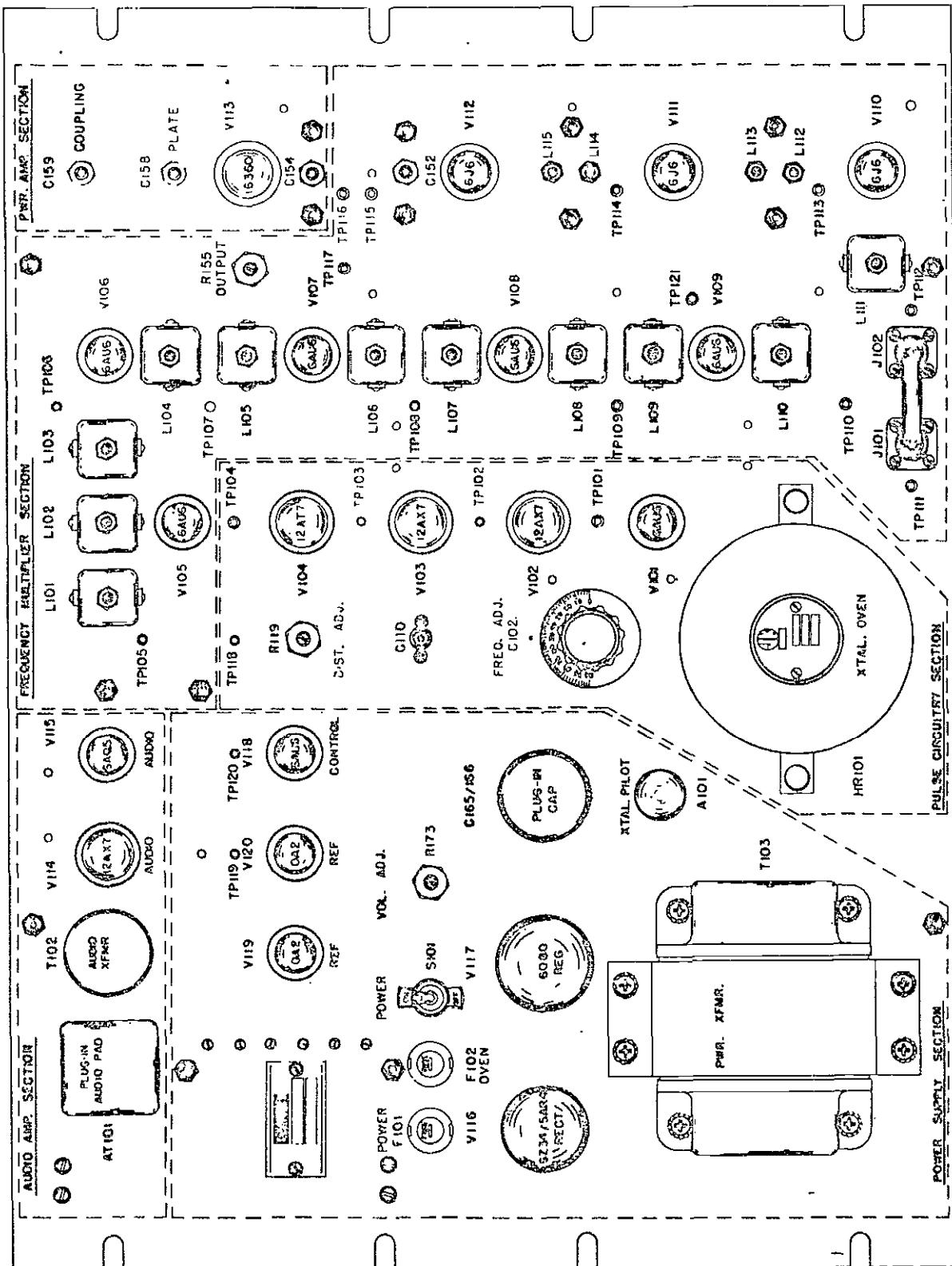

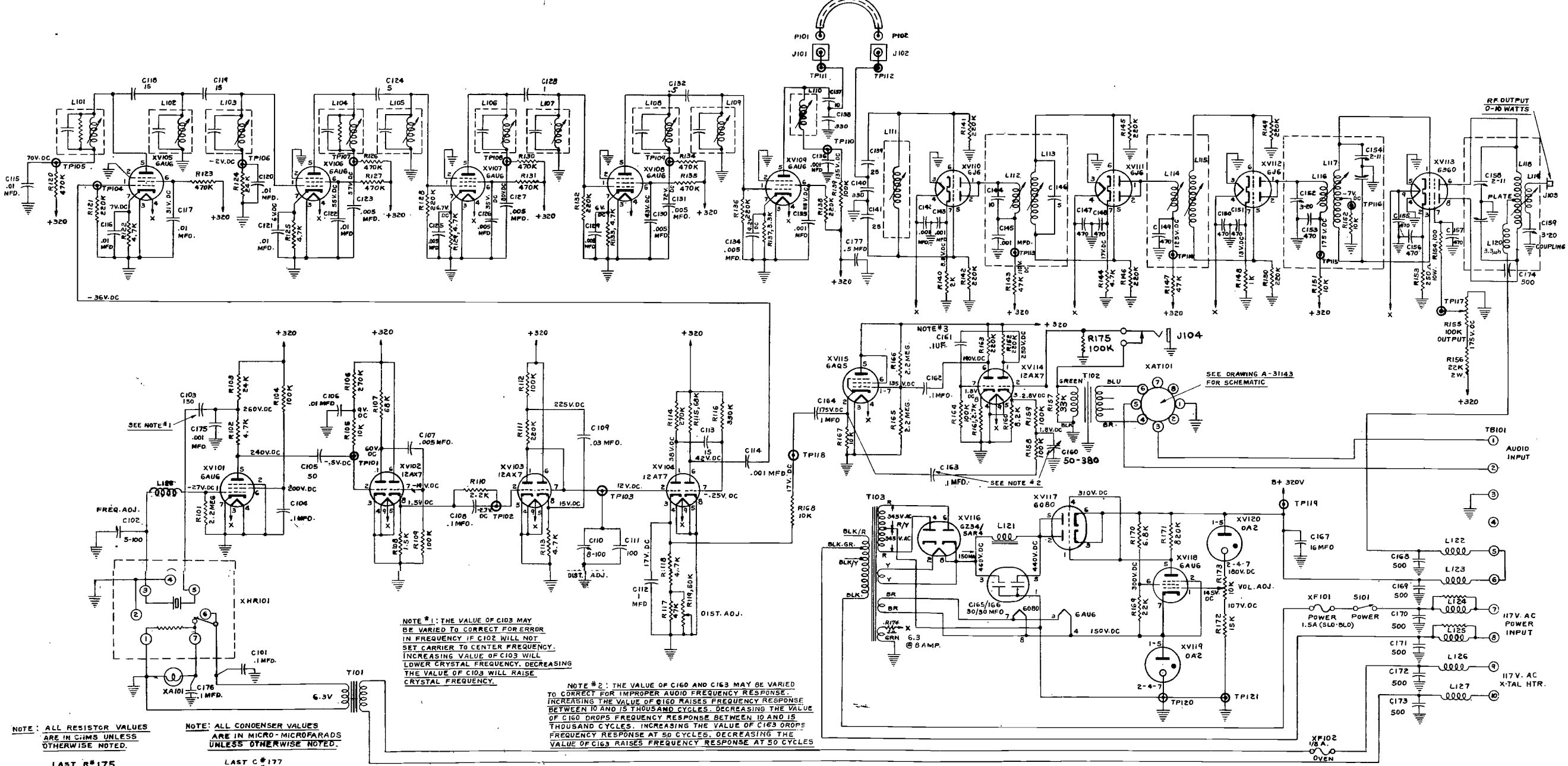

NOTE: ALL RESISTOR VALUES ARE IN OHMS UNLESS OTHERWISE NOTED.

NOTE: ALL CONDENSER VALUES ARE IN MICRO-MICROFARADS UNLESS OTHERWISE NOTED.

NOTE #1: THE VALUE OF C103 MAY BE VARIED TO CORRECT FOR ERROR IN FREQUENCY IF C102 WILL NOT SET CARRIER TO CENTER FREQUENCY. INCREASING VALUE OF C103 WILL LOWER CRYSTAL FREQUENCY. DECREASING THE VALUE OF C103 WILL RAISE CRYSTAL FREQUENCY.

NOTE #2: THE VALUE OF C160 AND C163 MAY BE VARIED TO CORRECT FOR IMPROPER AUDIO FREQUENCY RESPONSE. INCREASING THE VALUE OF C160 RAISES FREQUENCY RESPONSE BETWEEN 10 AND 15 THOUSAND CYCLES. DECREASING THE VALUE OF C160 DROPS FREQUENCY RESPONSE BETWEEN 10 AND 15 THOUSAND CYCLES. INCREASING THE VALUE OF C163 DROPS FREQUENCY RESPONSE AT 50 CYCLES. DECREASING THE VALUE OF C163 RAISES FREQUENCY RESPONSE AT 50 CYCLES.

NOTE #3 FOR SOME APPLICATIONS THE VALUE OF C161 MAY HAVE TO BE RAISED TO AS SMALL A VALUE AS .002 UF TO ROLL OFF LOW FREQ. BELOW 50 CYCLES.

GATES RADIO COMPANY		LIST OF PARTS		DESCRIPTION		MATERIAL	
QTY.	QTY.	QTY.	QTY.	QTY.	QTY.	QTY.	QTY.
100	102	104	103	101	105	106	107
108	110	112	111	113	114	115	116
117	118	119	120	121	122	123	124

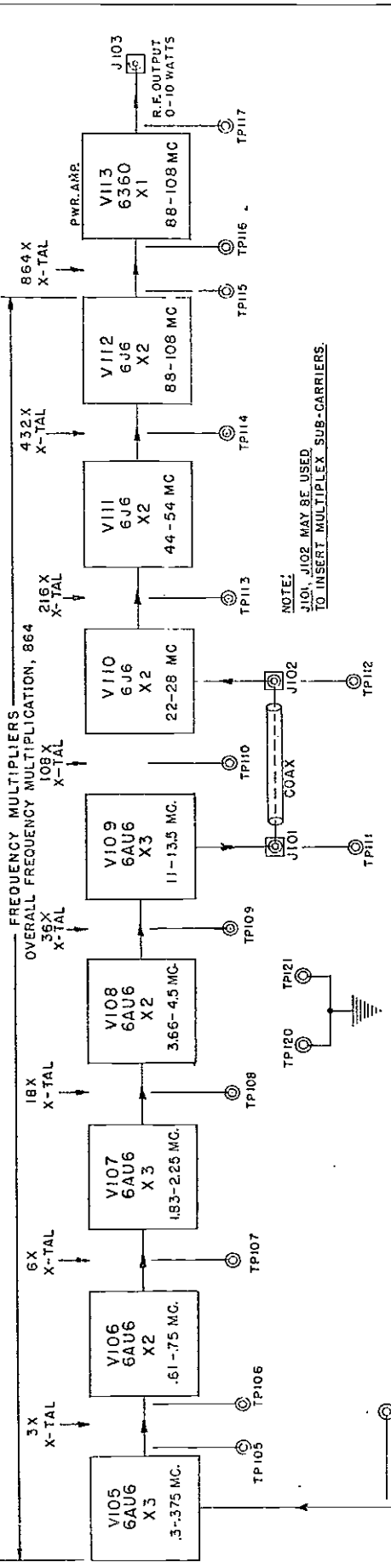

EXPLANATIONS:

NOTATIONS MADE JUST ABOVE THE UPPER ROW OF BLOCKS GIVE INFO. ON HOW MANY TIMES X-TAL FREQUENCY HAS BEEN RAISED AT THAT POINT. (EXAMPLE 216 X X-TAL MEANS THAT CIRCUITS BETWEEN V110 & V111 ARE TUNED TO 216 TIMES CRYSTAL FREQUENCY)

X2 MEANS STAGE IS A DOUBLER.

X3 MEANS STAGE IS A TRIPLER.

FREQUENCIES NOTED IN BLOCKS REFER TO THE PLATE CIRCUIT OF THAT STAGE.

APPROXIMATE LOCATION OF TEST POINTS ARE SHOWN BY TP101 THRU TP121

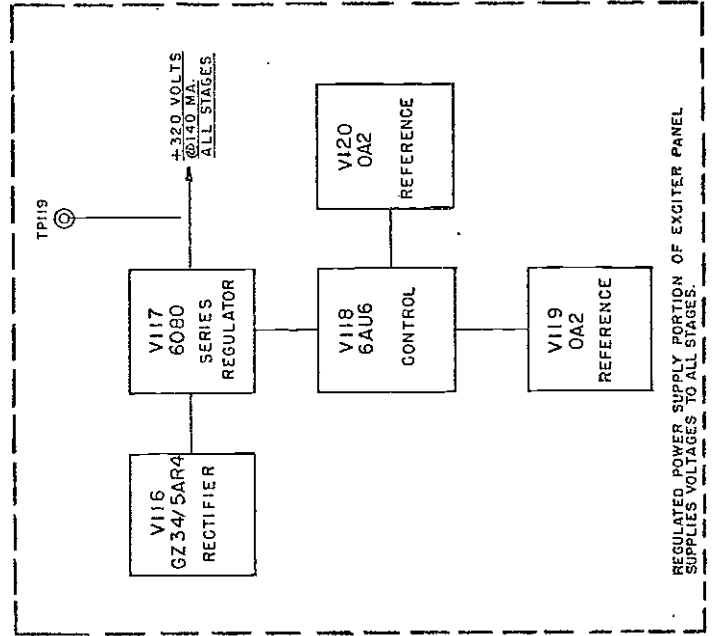

NOTE: J101 IS A PLUG-IN UNIT. MAY BE FLAT OR CONTAIN STANDARD 75 MICRO-SECOND. PRE-EMPHASIS. SEE R31143.

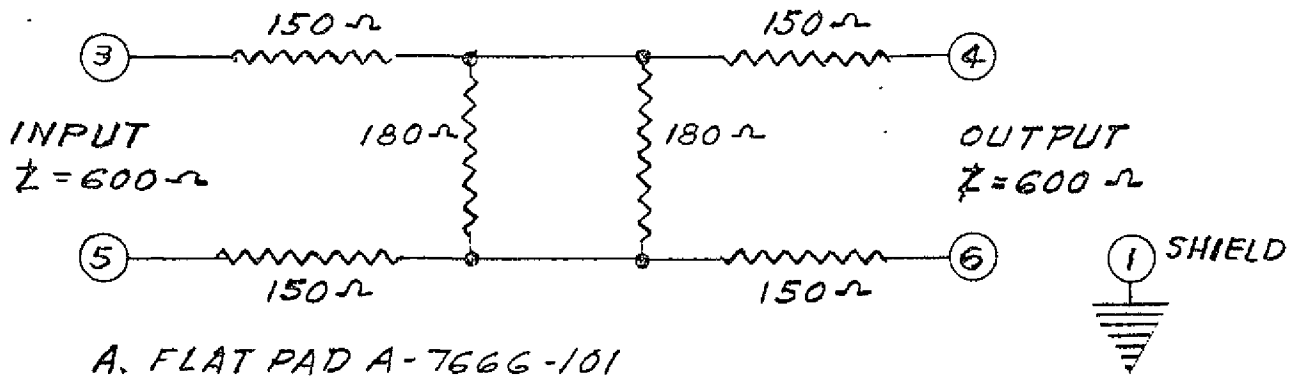

A. FLAT PAD A-7666-101
 INSERTION LOSS 17.5 DB. 50 TO 15,000 CYCLES
 (CIRCLED NUMBERS SHOW CONNECTIONS TO OCTAL PLUG)

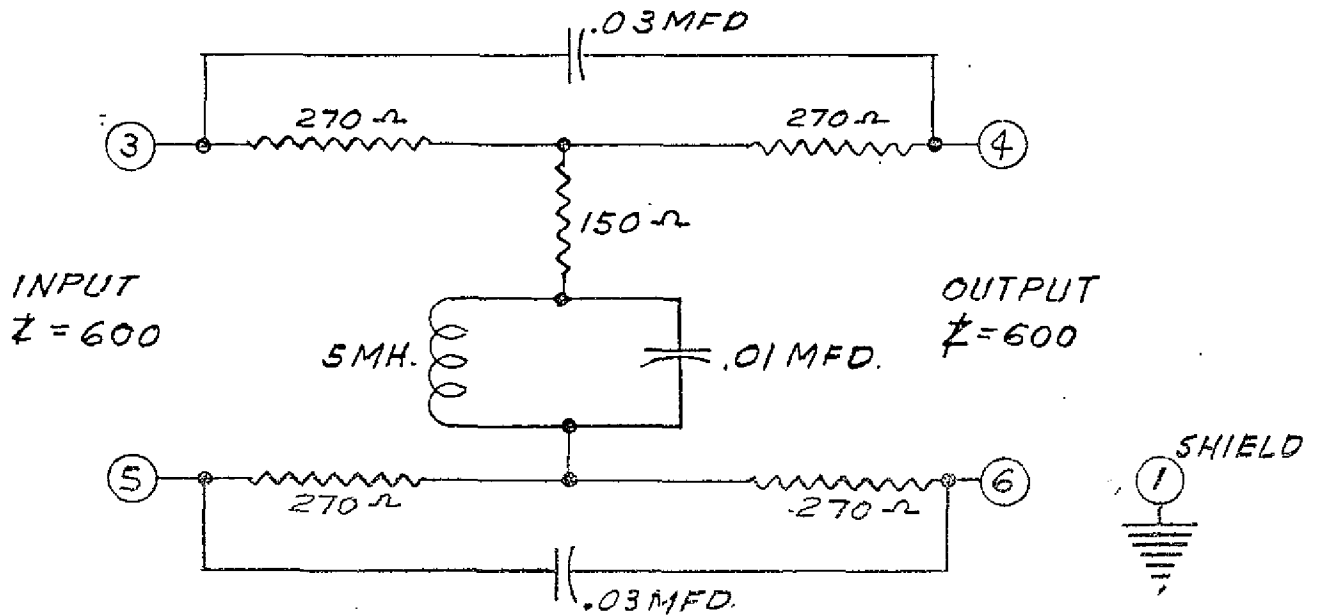

B. PRE-EMPHASIS PAD M5486
 INSERTION LOSS 17.5 DB. AT 400 CYCLES.
 (SEE ES-6170 FOR RESPONSE CURVE)
 (CIRCLED NUMBERS SHOW CONNECTIONS TO OCTAL PLUG)

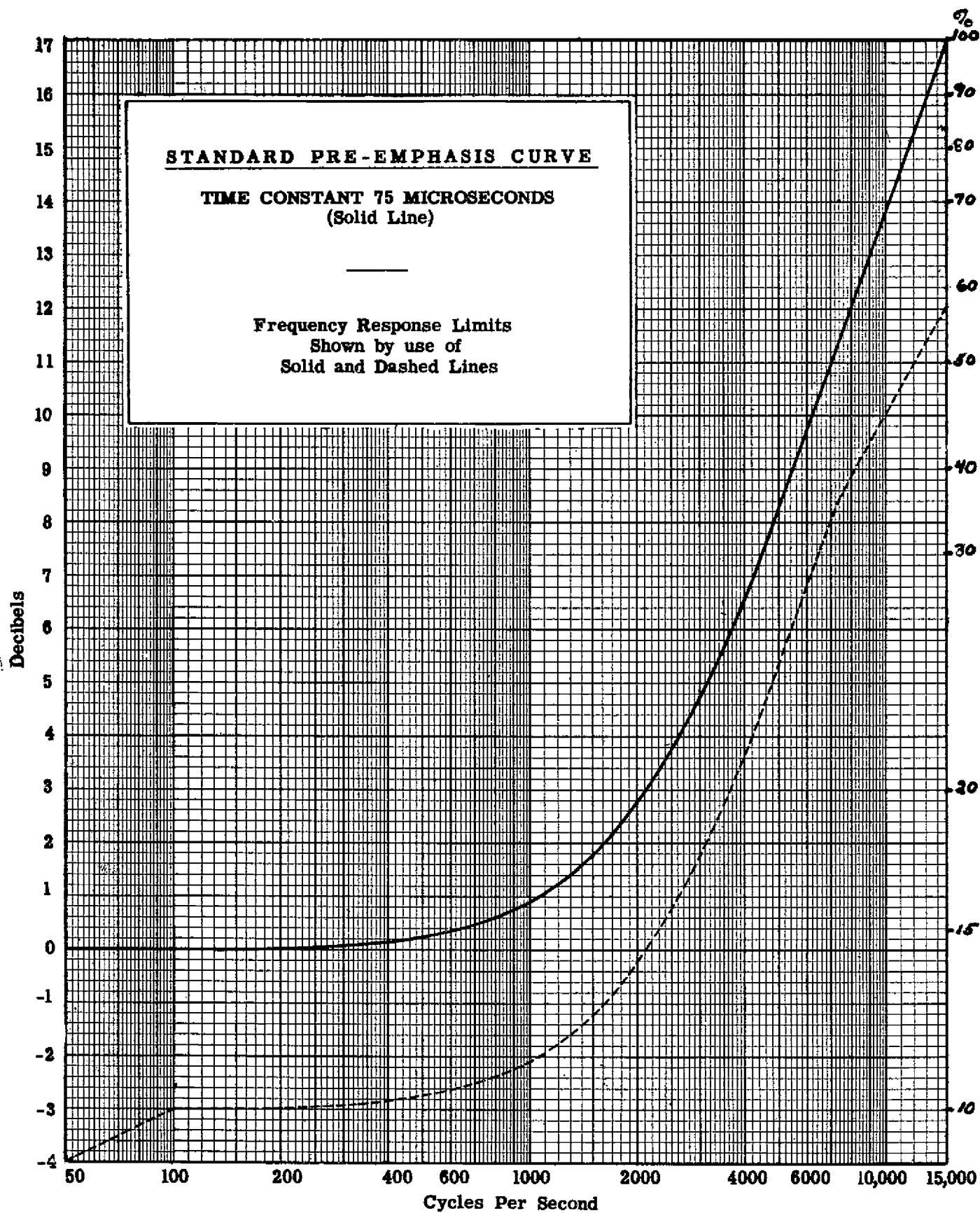
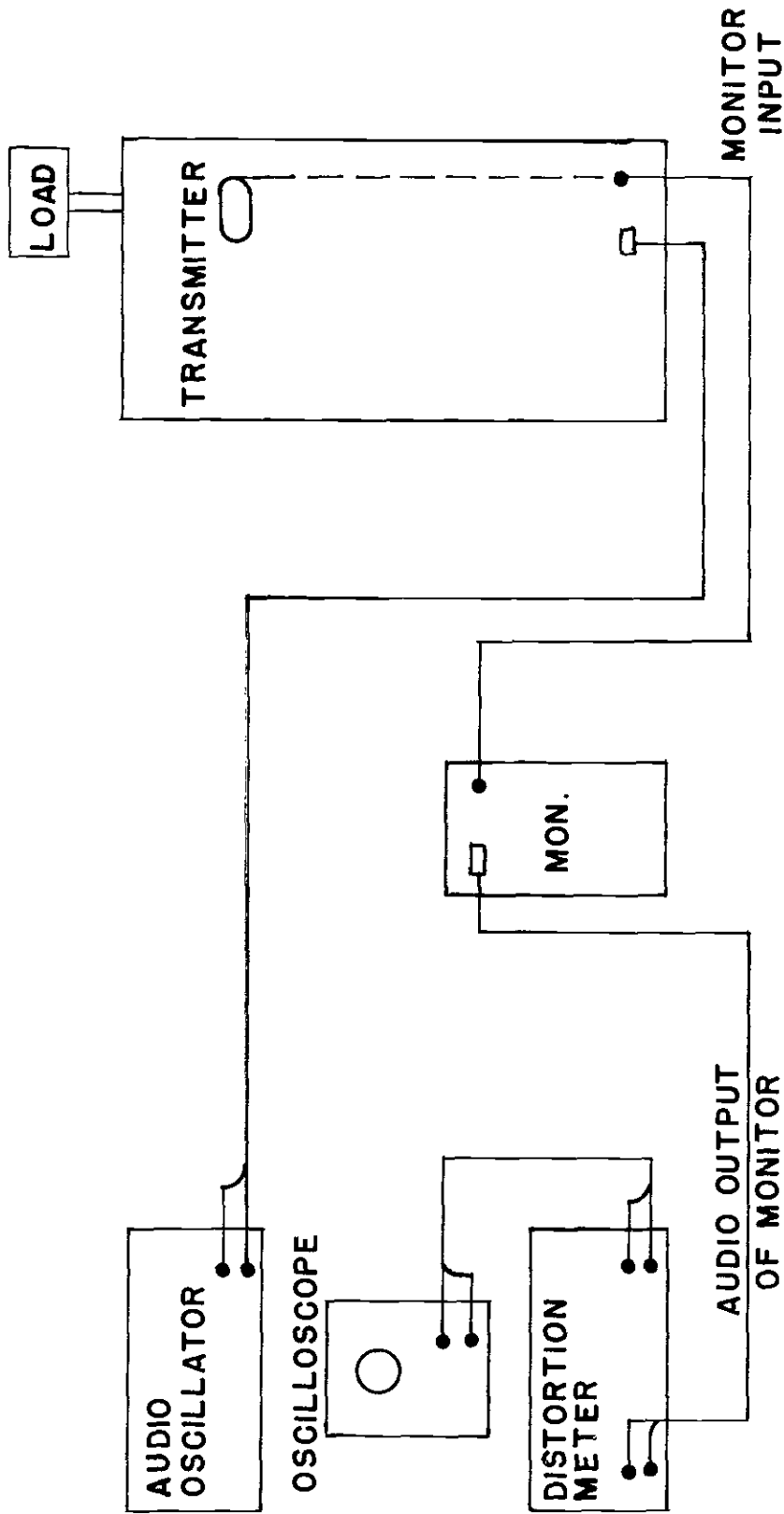
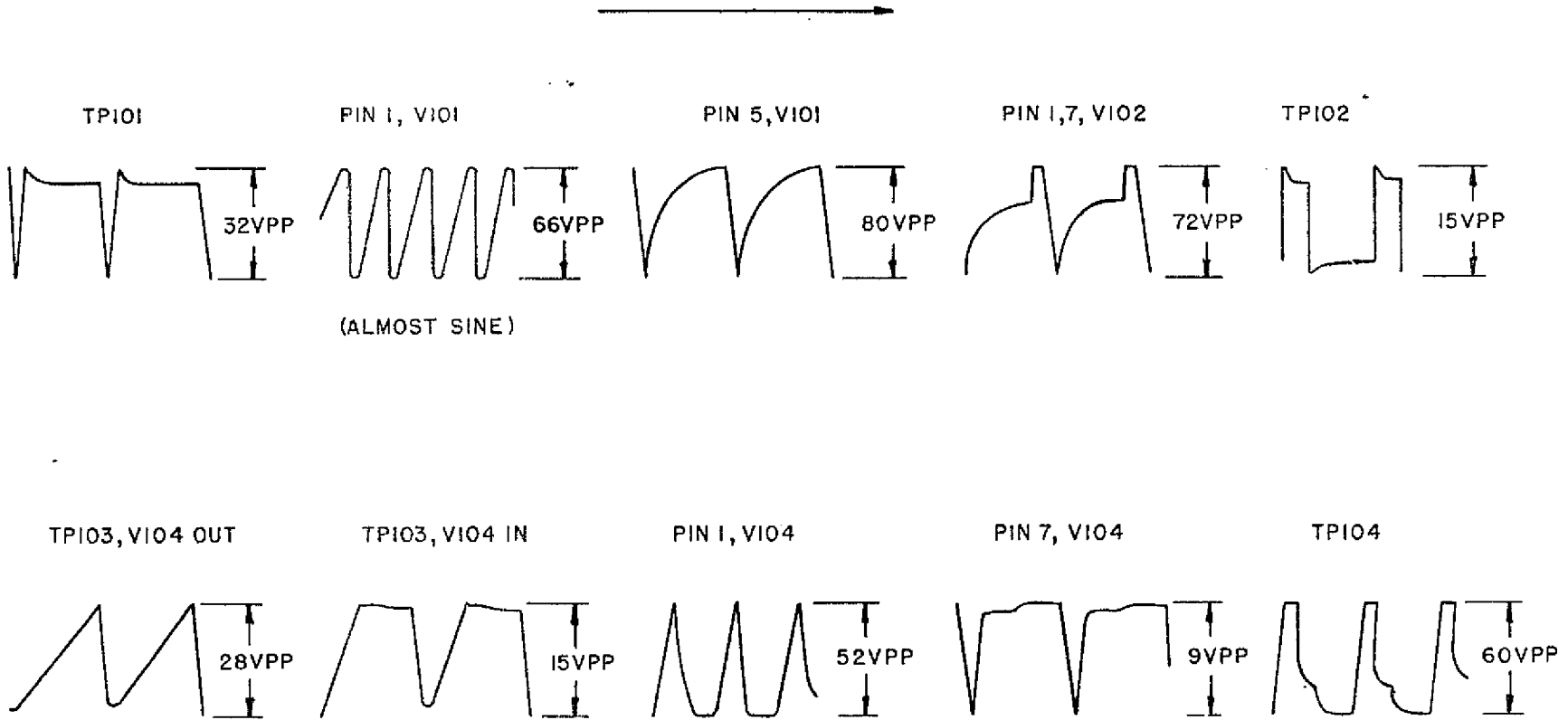

FIGURE 12



TEST SETUP FOR F.M.

A-4165



NOTE:
THE ABOVE PP WAVEFORM MEASUREMENTS WERE
MADE WITH A MODEL 524 AD TEXTRONIX SCOPE
AN UNCALIBRATED SCOPE MAY BE CALIBRATED BY
USING FILAMENT VOLTAGE TO SET A REFERENCE.
PEAK TO PEAK VOLTAGE EQUALS 2.8 X RMS VALUE.
6.3 VAC = 17.5 VPP.

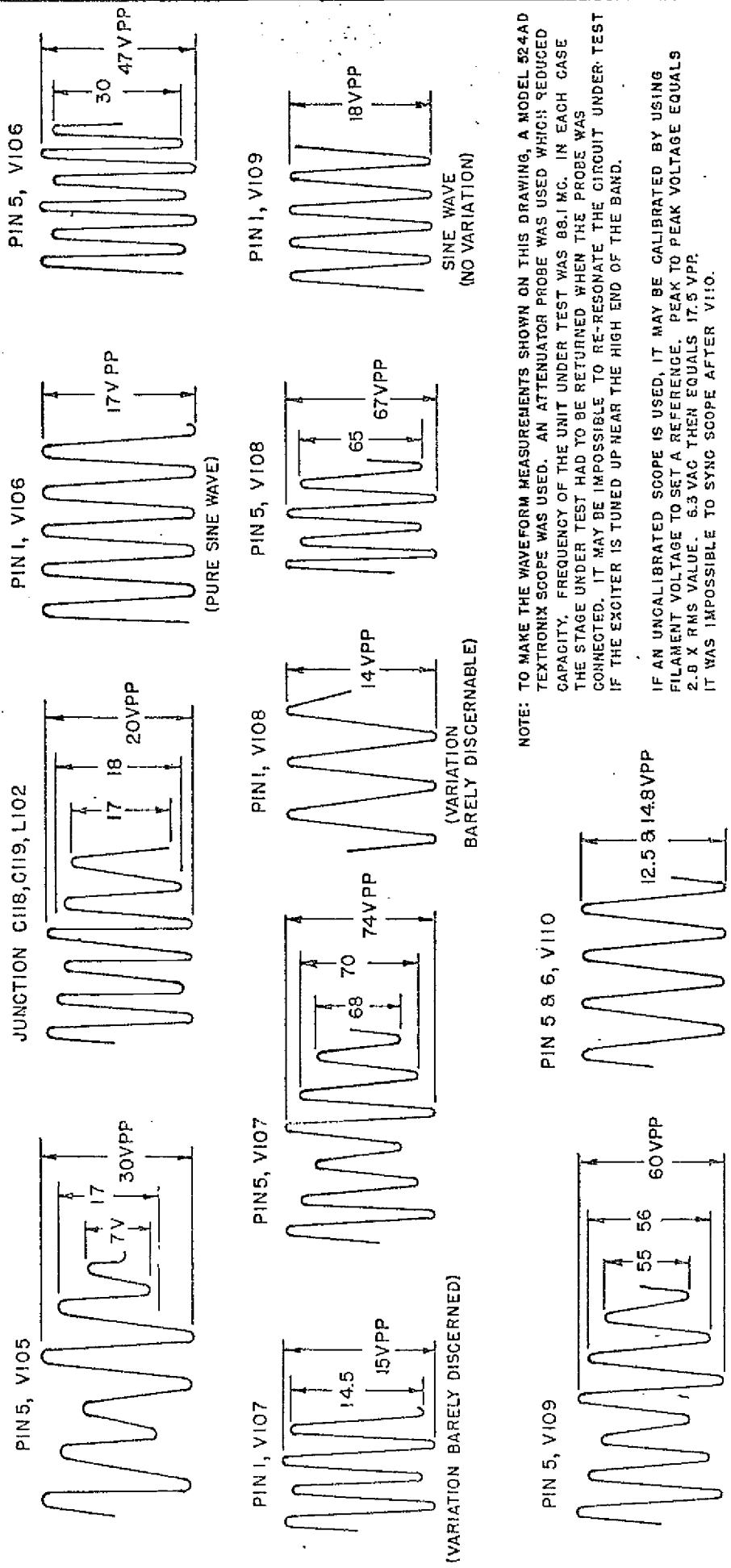

NOTE: TO MAKE THE WAVEFORM MEASUREMENTS SHOWN ON THIS DRAWING, A MODEL 524AD
 TEXTRONIX SCOPE WAS USED. AN ATTENUATOR PROBE WAS USED WHICH REDUCED
 CAPACITY, FREQUENCY OF THE UNIT UNDER TEST WAS 88.1 MC. IN EACH CASE
 THE STAGE UNDER TEST HAD TO BE RETURNED WHEN THE PROBE WAS
 CONNECTED. IT MAY BE IMPOSSIBLE TO RE-RESONATE THE CIRCUIT UNDER TEST
 IF THE EXCITER IS TUNED UP NEAR THE HIGH END OF THE BAND.

IF AN UNCALIBRATED SCOPE IS USED, IT MAY BE CALIBRATED BY USING
 FILAMENT VOLTAGE TO SET A REFERENCE PEAK TO PEAK VOLTAGE EQUALS
 2.8 X RMS VALUE. 6.3VAC THEN EQUALS 17.5 VPP.
 IT WAS IMPOSSIBLE TO SYNC SCOPE AFTER V110.

TYPICAL WAVEFORMS OF STAGES
 V105 THROUGH V110, M5534 EXCITER

**HARRIS
INTERTYPE
CORPORATION**

GATES[®]

A DIVISION OF HARRIS-INTERTYPE

123 HAMPSHIRE ST. • QUINCY, ILLINOIS • 62301 • U.S.A.