

**TECHNICAL
MANUAL**

M-6542

DUALUX II CONSOLE

**HARRIS
INTERTYPE
CORPORATION**

GATES[®]

WARRANTY

Seller warrants new equipment manufactured by Gates Radio Company against defects in material or workmanship at the time for delivery thereof, that develop under normal use within a period of one year (6 months on moving parts) from the date of shipment, of which Purchaser gives Seller prompt written notice. Other manufacturers' equipment, if any, including electron tubes, and towers shall carry only such manufacturers' standard warranty.

Seller's sole responsibility for any breach of the foregoing provision of this contract, with respect to any equipment or parts not conforming to the warranty or the description herein contained, is at its option, (a) to repair or replace such equipment or parts upon the return thereof f.o.b. Seller's factory within the period aforesaid, or (b) to accept the return thereof f.o.b. Purchaser's point of installation, whereupon Seller shall either (1) issue a credit to Purchaser's account hereunder in an amount equal to an equitable portion of the total contract price, without interest, or (2) if the total contract price has been paid, refund to Purchaser an equitable portion thereof, without interest.

If the Equipment is described as used, it is sold as is and where is. If the contract covers equipment not owned by Seller at this date it is sold subject to Seller's acquisition of possession and title.

Seller assumes no responsibility for design characteristics of special equipment manufactured to specifications supplied by or on behalf of Purchaser.

Seller shall not be liable for any expense whether for repairs, replacements, material, service or otherwise, incurred by Purchaser or modifications made by Purchaser to the Equipment without prior written consent of Seller.

EXCEPT AS SET FORTH HEREIN, AND EXCEPT AS TO TITLE, THERE ARE NO WARRANTIES, OR ANY AFFIRMATIONS OF FACT OR PROMISES BY SELLER, WITH REFERENCE TO THE EQUIPMENT, OR TO MERCHANTABILITY, INFRINGEMENT, OR OTHERWISE, WHICH EXTEND BEYOND THE DESCRIPTION OF THE EQUIPMENT ON THE FACE HEREOF.

RETURNS AND EXCHANGES

Do not return any merchandise without our written approval and Return Authorization. We will provide special shipping instructions and a code number that will assure proper handling and prompt issuance of credit. Please furnish complete details as to circumstances and reasons when requesting return of merchandise. Custom built equipment or merchandise specially ordered for you is not returnable. Where return is at the request of, or for the convenience of the customer, a restocking fee of 15% will be charged. All returned merchandise must be sent freight prepaid and properly insured by the customer. When writing to Gates Radio Company about your order, it will be helpful if you specify the Gates Factory Order Number or Invoice Number.

WARRANTY ADJUSTMENTS

In the event of equipment failure during the warranty period, replacement or repair parts may be provided in accordance with the provisions of the Gates Warranty. In most cases you will be required to return the defective merchandise or part to Gates f.o.b. Quincy, Illinois for replacement or repair. Cost of repair parts or replacement merchandise will be billed to your account at the time of shipment and compensating credit will be issued to offset the charge when the defective items are returned.

MODIFICATIONS

Gates reserves the right to modify the design and specifications of the equipment shown in this catalog without notice or to withdraw any item from sale provided, however, that any modifications shall not adversely affect the performance of the equipment so modified.

INSTRUCTION BOOK
FOR
DUALUX II
GATES M6542 MONO/STEREO
TRANSISTOR CONSOLE

IB-888 0928 001

Gates Radio Company
Quincy, Illinois

<u>INDEX</u>	<u>PAGE</u>
SPECIFICATIONS	1
INTRODUCTION	2
INSTALLATION	2
A. Unpacking Instructions	2
B. Audio System Installation Information	3
C. Installation Procedure	4
a. Power Connections	4
b. Warning Lights	4
c. Input Connections to Console	4
d. Output Connections to Console	6
OPERATIONS	7
a. Master Gain Adjustment	9
MODE Switch Operations	10
b. Cue-Intercom System	12
MAINTENANCE	12
A. Trouble Shooting	12
Trouble Shooting Guide	13
B. Special Conditions	14
PRINCIPLE OF MUTING	15
Studio "A" Muting Schematic	16
TABLE I	17
NOTES	18
LOSS PAD CHART	19
PARTS LIST	
DIAGRAMS -	
A. Amplifier Schematics	
B. Composite Drawings	
C. System Block and Schematic	

SPECIFICATIONS

Microphone to Regular Program Line Out

Gain: 100 dB \pm 2 dB at 1,000 Hz., FM Channels
98 dB \pm 2 dB at 1,000 Hz., AM Channel

Response: \pm 1.0 dB from 20 to 20,000 Hz.

Distortion: 0.5% or less from 20 to 20,000 Hz.,
at +18 dBm out.

Noise: 74 dB below +18 dBm output with -50 dBm
output (20 to 20,000 Hz). The equivalent
input noise is -124 dBm or better.

Crosstalk: In the noise with normal levels and
control positions.

Medium Level Inputs

(Remote, Tape, Net & Turntable Inputs to regular program Line Out).

Gain: 60 dB \pm 2 dB at 1,000 Hz., FM Channels
58 dB \pm 2 dB at 1,000 Hz., AM Channel

Response: \pm 1.0 dB from 20 to 20,000 Hz.

Distortion: 0.5% or less from 20 to 20,000 Hz at
+18 dBm output.

Noise: 74 dB below +18 dBm output with -10 dBm input.

Monitor Circuits

Gain: 101 dB minimum dB from microphone to monitor out.
73 dB \pm 2 dB from ext. to monitor out.

Response: \pm 1 dB from 20 to 20,000 Hz at +30 dBm.

Distortion: 1% or less from 20 to 20,000 Hz at +40 dBm
(10 watts).

Power Requirements

Primary
Power: 105/125 volts RMS, 50/60 cycles,
80 watts (approximately)

Mechanical Specifications

Console: 51-3/4" wide, 17" deep, 11-1/2" wide.

Transformer
Panel: 5" x 19" Panel, overall depth.

Output and Power Supply Modules.

INTRODUCTION

The Dualux II console is a stereo/mono console providing all the necessary functions and facilities for the radio station that broadcasts stereophonic and/or monophonic/SCA programs. The console is capable of feeding a stereo or mono/SCA signal to an FM stereo transmitter and a monophonic signal to the AM transmitter simultaneously. A special mode switch is provided for setting up these various modes of operation.

Input channels ONE and TWO are monophonic microphone channels switchable into the AM or FM program channels. Input selection is provided for control room and studio microphone feeds. Channel THREE is a stereo microphone input channel switchable into the AM or stereo FM program channels. Stereo input selection is provided for control room and studio microphone feeds. Channels FOUR, FIVE, SIX and SEVEN are medium level inputs used for turntable and tape programming. Channel EIGHT has four remote inputs and one net input.

Monitoring is available for the AM program channel, the stereo FM program channels and external sources, such as AM and FM stereo air monitors. Headphone monitoring is provided by an external jack plate mounted at a location suitable to the user. A selector switch is provided for AM, FM, CUE and NET monitoring. In addition, a stereo headphone jack is located on the right end of the console and connected to the output of the monitor amp.

INSTALLATION

A UNPACKING INSTRUCTIONS

The console will arrive in several boxes or cartons with the following items enclosed.

1. Dualux II Console with amplifiers and power supplies installed.
2. Power Transformer Panel.
3. Knob Decal Kit.
4. Stick-on Labels.
5. This Instruction Book.
6. Eight Speaker Transformers.
7. Jack Plate

These boxes should be unpacked carefully and inspected for shipping damage. If damage is found, contact the shipper immediately. After he has approved the damage report, which indicates he will accept your billing for the damage, order new parts from Gates Radio Company. Our billing of these parts plus transportation expense will be your claim to the Transportation Company.

The Dualux II console is covered under the Standard Gates Warranty, a copy of which may be had on request from Gates Radio Company, 30th and Wisman Lane, Quincy, Illinois 62301.

B. AUDIO SYSTEM INSTALLATION INFORMATION

Before any actual installation is started, the following points should be studied carefully, physical location of all components should be decided and cable routing should be determined. Only after these plans have been completed, may installation be made in an orderly manner.

The transformer panel is 5-1/4" x 19" and can be rack mounted. If desired, it may be mounted in a small wall box or under the base of a desk. Ample ventilation must be provided since the unit generates some heat. When rack mounted, the panel is designed for natural convection cooling. If the ambient temperature of the rack is below 50°C. (122°F.), the rack does not need forced air ventilation.

Cable routing of external connections of various signal levels is of prime importance. The low level mic input cables should be cabled separate from all the other level cables.

If it is necessary to use cables of different levels in a common conduit, the difference between the lowest and the highest level in the two cables should not be greater than 40 dB.

Physical isolation is the best way to avoid trouble between parallel cables. Six inches or more spacing is preferred.

The console grounding system is based on the one point ground. Different circuit grounds are insulated from the chassis and go directly to the ground STUD located at the left end of the cabinet. Connect the station ground to the cabinet ground stud. External grounds connected to circuit grounds in the console will destroy this system.

A shield ground bus is provided beside both the input and output terminal blocks of the console. All incoming and outgoing shields must be connected to these busses.

C. INSTALLATION PROCEDURE

a. Power Connections

See installation drawing #852-6263-001 at rear of this book.

Input power connections are made on the transformer panel block TBX-1, Terminal 2 for 117 volts AC RMS and Terminal 1 for 117 volts common.

Interconnecting power cables, between console and transformer panel are supplied with the transformer panel. Connections can be made by following wire color code shown on Installation Drawing.

b. Warning Lights

117 VAC for the warning lights should be connected as follows: Terminal Nos. 5 and 6 of TBX-1 are for the control room warning lights, Terminal Nos. 7 and 8 of TBX-1 are for Studio A warning lights and Terminals 9 and 10 of TBX-1 are for Studio B warning lights.

Warning light circuits should not be grounded at any point and should not draw more than 2 amps of current.

c. Input Connections to Console

1. See installation drawing #852-6263-001 at rear of this book.

2. A shield ground bus is provided beside the input terminal block of this console. All incoming shields must be connected to this bus.

Twisted shielded pairs are to be used for all circuits, balanced or unbalanced. The shields are to be grounded at the shield bus in the console and nowhere else.

Channel One has provisions for two different mono microphone inputs. Front panel switching is provided.

Channel Two has provisions for two different mono microphone inputs. Front panel switching is provided.

Channel Three has provisions for two different pairs of stereo microphones. Front panel switching is provided.

Channel Four has provisions for any of four different stereo turntable and/or tape inputs. Front panel switching is provided.

Channel Five has provisions for any of the same four inputs that are available to Channel Four and are not being used by Channel Four. Front panel switching is provided.

Channel Six has provisions for any of four different mono turntable and/or tape inputs. Front panel switching is available.

Channel Seven has provisions for any of the same four inputs that are available to Channel Six and are not being used by Channel Six. Front panel switching is provided.

Channel Eight has provisions for any of four different remote lines and one network line. Front panel switching is provided.

For operating impedances, levels, modes and other associated information see Table 1, Page 17 of this book.

Turntable and tape inputs are unbalanced and the common side is grounded. Therefore, only use circuits with ungrounded outputs. If the external source has an unbalanced output, an isolation transformer such as Gates A-21 must be used.

Correct phase relationship is maintained within this console for stereo programming. It is therefore, up to the installer to make certain that all incoming signals are correctly phased to assure proper stereo perspective.

d. Output Connections to Console

1. See installation drawing #852-6263-001 at rear of this book.
2. A shield ground bus is provided beside the output terminal block of this console. All outgoing shields must be connected to this bus. Do not ground them at any other point.

The output line cables from this console are medium level and should be routed carefully to prevent crosstalk back into low level input circuits.

Again, observe correct phase relationship between output lines to insure proper sound perspective between the left and right channels.

All speaker wiring is high level and must be run in a separate conduit isolated from the low level program circuits. Stereo monitoring is provided for all studio as well as external lobby speakers. 45 to 16/8/4 ohm speaker matching transformers are supplied for paralleling 16/8/4 ohm speakers to the output of the monitor amplifier. Intercom speakers should present a 600 ohm load to the console terminals. These are available from Gates by ordering the M-6424 Studio Cue/ Intercom Speaker Unit. Order one unit for each studio position. The 600 to 45 ohm transformer (only) is available as Gates 478-0274-000. Speaker connections are shown in the Installation Drawing.

The muting has been preassigned as indicated on the block diagram and shown on Page 14. For reassignment of muting, please see Page 15 of this book for instructions.

The earphone jack for both the cue-intercom and the line monitoring circuits is mounted externally on a jack panel. The panel should be mounted in a convenient location in the room and shielded twisted pairs should be used to connect to the console.

OPERATIONS

The switches with red knobs located above the channel keys for channel #1, #2 and #3 are for selection of two sets of microphones into these channels. Two sets of mono microphones are selected into channel #1 and #2, while two sets of stereo microphones are selected into channel #3.

The output of channel #1 and #2 feeds the AM bus in the normal manner when the channel key is in the AM position. With the channel key in the FM position, these channels feed both the Left and Right FM busses with an equal and in-phase signal. Channel #3 contains stereo preamplifiers which are combined to feed the AM bus in the AM position, or are split to provide a stereo feed into the FM bus in the FM position. Channel #3 also has a mono-stereo switch which bridges the input of the Right preamp across the output of the Left preamp to provide an equal and in-phase, yet isolated feed into the FM busses from a single microphone source.

The four switches above channel #4 and #5 select the desired stereo input to each mixer. When the input switches above mixer #4 are in the "OFF" position, the inputs are normalled through to the channel #5 switches. The switching is arranged so that a turntable or tape cannot be switched into mixer #5, if it is already switched into mixer #4. This prevents loading the turntable or tape output by paralleling it into two console inputs. Cueing facilities are provided by turning either mixer fader fully counterclockwise. This connects the turntable or tape into the cue-intercom amp. Cueing can be accomplished by using the panel mounted speaker or headphones.

The four switches above channel #6 and #7 select the desired mono input to each mixer. When the input switches above mixer #6 are in the "OFF" position, the inputs are normalled through to the channel #7 switches. The precedence and cueing on channel #6 and #7 are similar to those explained for #4 and #5. When the channel keys for channel #6 and #7 are thrown to the FM position, the program is fed to the FM Left Bus only.

The first four lever switches located above channel #8 control the four remote inputs. The remote switches provide talkback and cueing facilities to the remote operator. In the center position, the remote operator receives the program cue signal from the monitoring amplifier. The lower position is the "mix" position and connects the remote program into the AM or FM Left program bus through channel #8. The upper position of the switches have a terminating load for the remote lines and provides talkback functions. The remote lines are not tied together when any or all of the remote keys are in the "talkback" position.

The network input is connected to channel #8 when the net input switch is in the "mix" position. Preview monitoring of the network is provided by either turning the mixer control fully counterclockwise into the "cue" position or rotating the cue selector switch to the "net" position.

The monitor input selector is located on the lower center of the panel. Input switching allows stereo monitoring of the FM program or an external stereo signal source, and mono monitoring of the AM program and an external mono signal source. The gain of both the "Left" and "Right" monitor amplifiers is controlled by the dual gain control located just below the monitor input selector.

The inputs and outputs of the program amplifiers are selected by the 8-station selector switch located on the upper center of the panel. The following are the 8 different selections of this switch -- AM normal, FM programs, AM, AM automation, FM mono, AM programs Mono FM, FM automation, stereo FM and SCA programming.

The following two pages show 10 different combined modes of operation for the program output selector.

a. Master Gain Adjustment

The gain controls for AM, FM left and FM right program channels are located on the upper center section of the panel.

Once the gain of the FM left program channel has been adjusted to the desired level, the inter-channel (left-right) balance can be set by switching the channel balance switch to the "null" position. This switch is located on the meter pad board fastened to the back of the FM Left Meter. With the switch in the "null" position, VU meter #2 is connected between the FM left and FM right program channels, and thus reads the difference in signal levels between channels. Feed a monophonic recording into a stereo turntable channel and adjust for normal output level, then adjust the level of the FM right program gain control until VU meter #2 nulls. This indicates the lines are balanced within ± 0.5 dB at +8 VU output. After the balancing procedure is completed, the switch should be returned to the "operate" position.

MODE 1 - - Separate AM and FM Monophonic

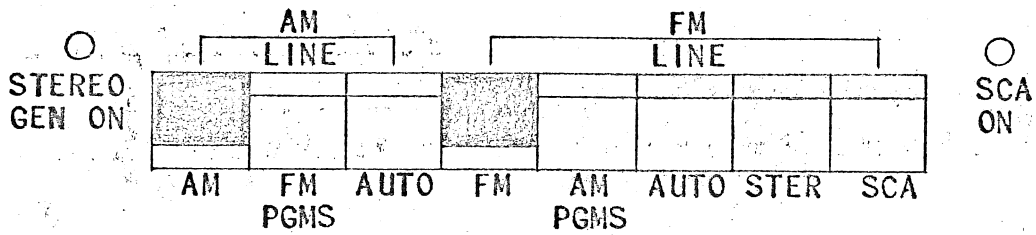

MODE 2 - - AM Mono with Separate FM Stereo

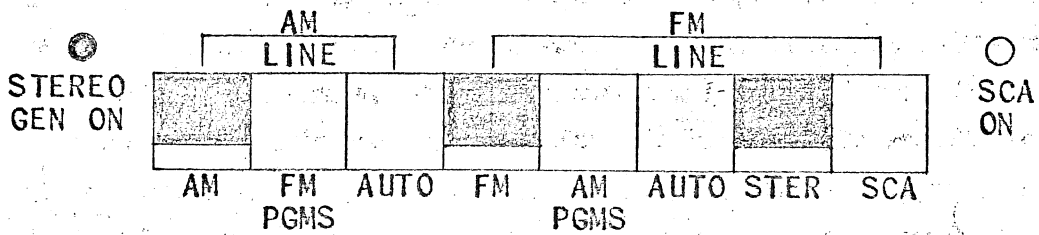

MODE 3 - - Combined Programming from AM

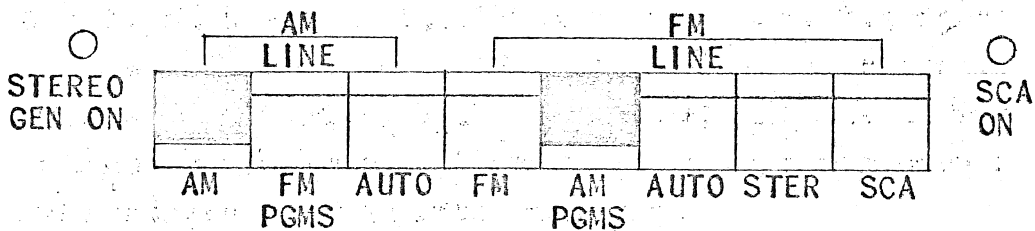

MODE 4 - - Combined Programming from FM Stereo

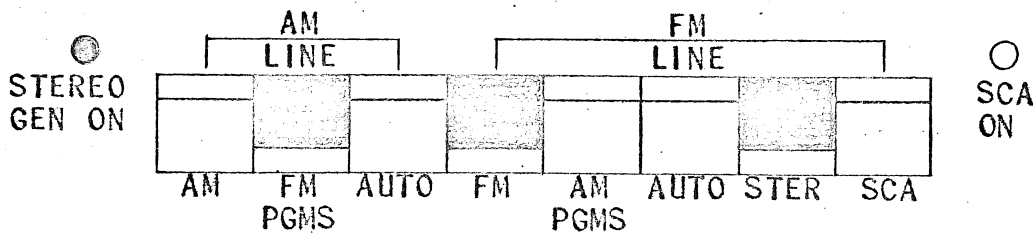

MODE 5 - - Separate Programming with SCA

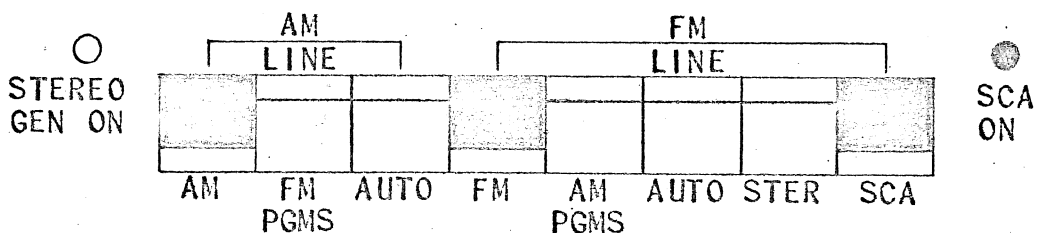

MODE 6 - - AM Mono, FM Stereo Automation

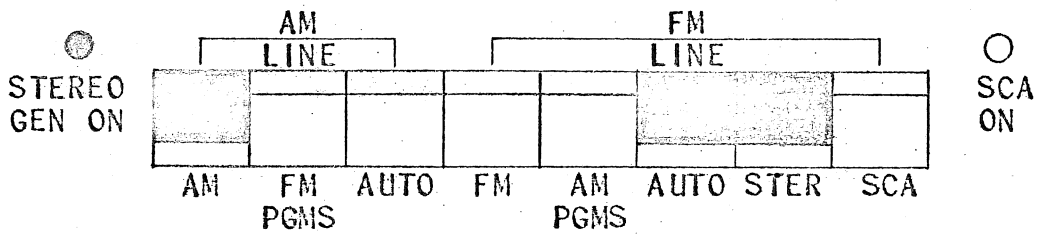

MODE 7 - - Combined AM and FM from FM Automation

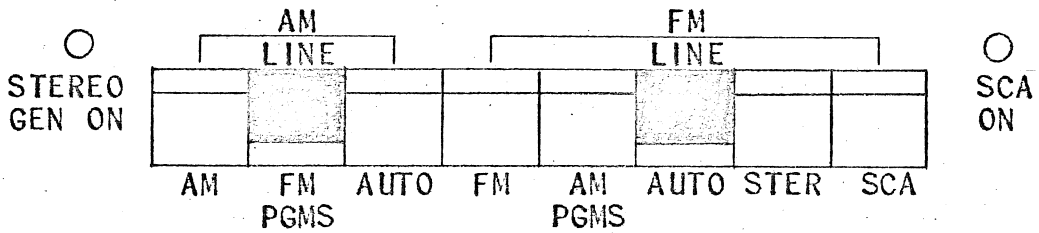

MODE 8 - - FM Stereo with AM Automation

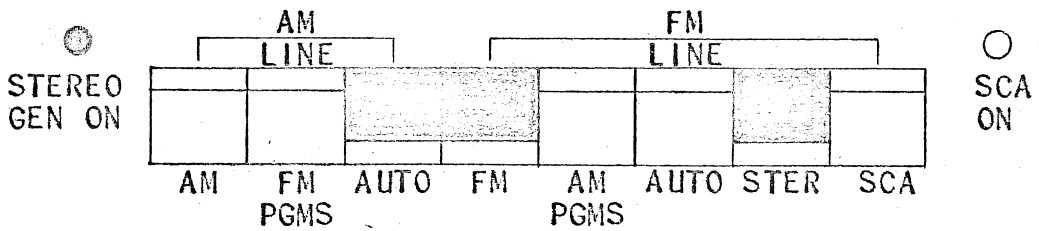

MODE 9 - - AM Auto, FM Mono and SCA

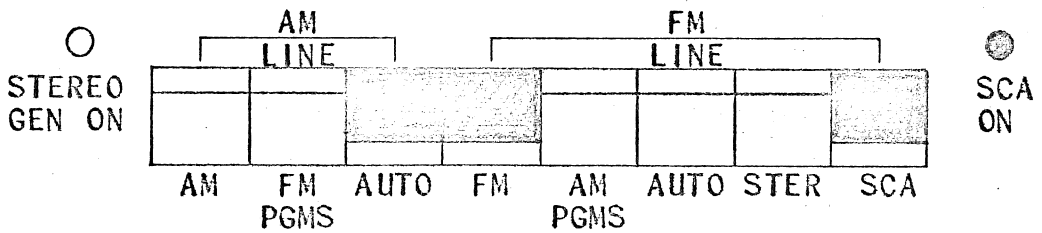

MODE 10 - - Combined Programming with SCA

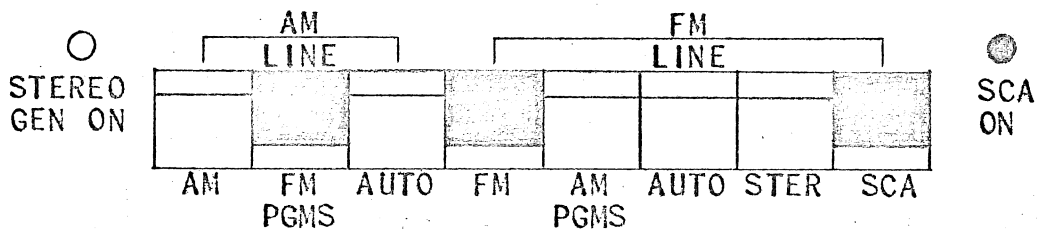

b) Cue-Intercom System

The controls are located on the lower center section of the panel.

The cue-intercom input selector switch is provided with 8 input positions. The first position "net" is used for monitoring the input network line. Talkback is not possible in the "network" position. Next, the "remote 1", "2", "3" and "4" positions tie the cue-intercom to the individual remote lines. For talkback facilities, the intercom selector is switched to the desired remote line and the corresponding remote input switch is placed in the "TB" position. The incoming remote signal line will then be heard on the cue-intercom speaker. When the control room operator desires to talk to the remote operator, he simply pushes the red "Talk" button in the center of the panel and speaks into the panel speaker. "ST-A" and "ST-B" positions allow listening and talkback into Studio A and Studio B, if suitable intercom units have been installed in them.

Turntable and tape cueing circuits are connected directly to the input of the cue-intercom amp and may be used regardless of the position of the cue-intercom input selector. However, in the "cue" position nothing else is connected to the input of the cue-intercom amp.

The cue-intercom speaker on the console is set up to be muted by the channel #1 lever key, however, this muting does not disable the cue phone jack, so it is still possible to cue a record by monitoring the cue circuit with headphones.

Another headphone jack is located on the right end of the console cabinet. This jack is connected to the monitor output for stereo headphone monitoring.

Speaker muting is accomplished by using a microsecond solid state muting circuit. Since no relays are used for muting, the chance of feedback between the monitor speaker and microphone is practically non-existent.

MAINTENANCE

A. TROUBLE-SHOOTING

Voltage measurements are invaluable for trouble-shooting and are given on the schematic diagrams of the various amplifiers. It is recommended that, after the console is installed and operating satisfactorily, these readings be checked and recorded on the schematic. This will provide the station engineer with a record of the actual voltage readings in his installation, using his meter. If trouble later develops, he will then be

better able to judge whether or not a particular circuit is operating properly since he will have available a record of the various readings of his particular equipment. DC readings were taken with a 20,000 ohm/voltmeter as indicated on the schematic. RMS signal voltages are shown in parenthesis and must be measured with a vacuum tube voltmeter. If a VTVM is used to measure DC voltages, slightly higher readings may be obtained.

TROUBLE-SHOOTING GUIDE

1. No indication can be seen on any one of the VU meters and the monitors will only operate from the external input.
 - a) Interchange the program amps with the monitor amps.
 - b) Check for 33 volts between terminals #3 and #5 of the booster board and terminals #3 and #9 of the output board in the program amps.
2. No signal can be measured on any one of the program output lines, but indication can be seen on the VU meter.
 - a) Check external cable connections on TB2.
 - b) Check switch contacts on the program output selector.
3. No signal can be heard from any of the monitor speakers but the program channels operate O.K.
 - a) Interchange the monitor amps with the program amps.
 - b) Check for 33 volts between terminals #3 and #5 of the booster board and 43 volts between terminals #3 and #9 of the output board in the monitor amps.
4. No signal can be heard from the cue speaker.
 - a) Interchange the cue amp with either the program or monitor amp.
 - b) Check for 33 volts between terminals #3 and #5 of the booster board and terminals #3 and #9 of the output board.
 - c) Check cue speaker with an ohmmeter.
5. No indication can be seen on the VU meter when talking into the control room or studio microphones, but the medium level channels operate O.K.
 - a) Interchange preamps if only one or two channels show no indication.
 - b) Check for 33 volts between terminals #7 and #8 of the preamp.
 - c) Check contacts on switches, S1,S2,S3,S4,S26,S27 and S28.

6. No indication can be seen on the VU meter when feeding one or more of the medium level inputs.
 - a) Check the input switches, the channel mixer, and the channel lever key.
7. Control room or studio monitors will not operate but the lobby speakers operate O.K.
 - a) Check for 33 volts between terminals #7 and #9 on power supply #4.
 - b) Check contacts on switches S1, S2, S3, S26, S27 and S28.
 - c) Check each transistor on all three of the muting module boards.
8. Headphones will not operate when plugged into the headphone monitor jack.
 - a) Check the contacts on switch S34 and the phone jack.
 - b) Check the headphones.

B. SPECIAL CONDITIONS

When changing bulbs in the lever keys, make sure the power is turned off since the lamp socket may short to the chassis during the installation of the bulb. The socket is held in the switch by a spring clip, and may be removed from the rear of the switch body by pulling firmly on the socket wires.

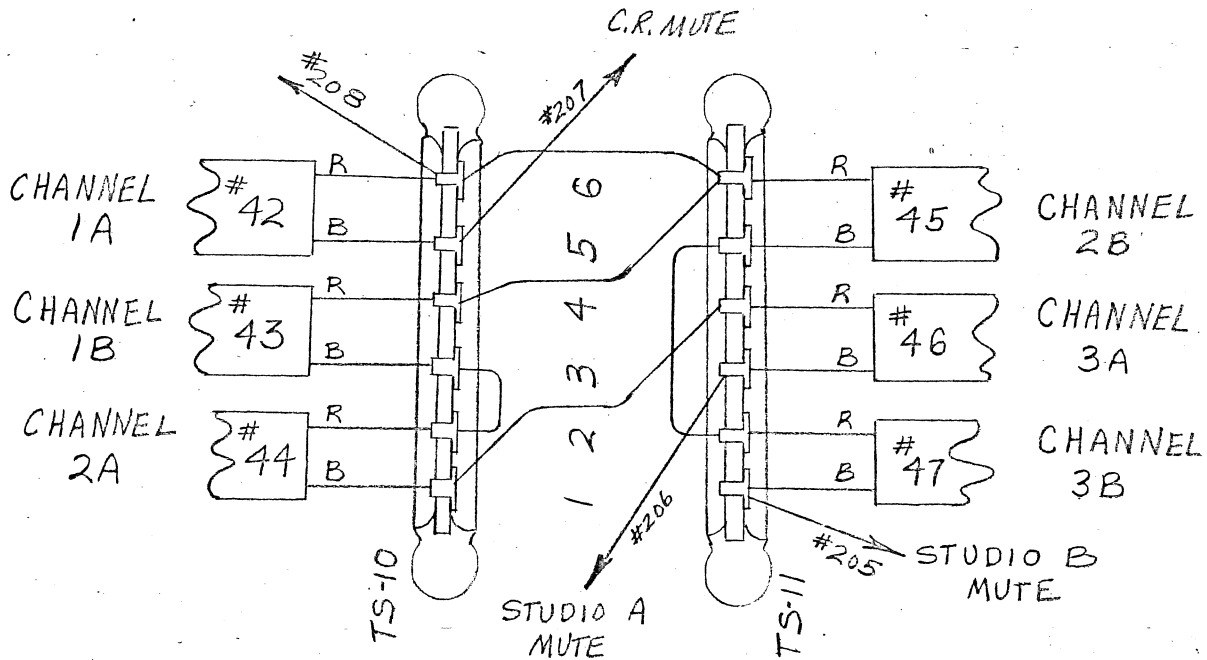

The tie strips shown above are located on the back of the front panel between S4 and S5. These are pre-wired to mute the control

room in channel #1 - position A; to mute the studio "A" speakers in channel #1 - position B, channel #2 - position A, and channel #3 - position A; and to mute the studio "B" speakers in channel #2 - position B, and channel #3 - position B. The channel A and B designations show the muting switch connections for position A and B of the input selector switch for each MIC channel.

Before attempting to reassign the muting, a complete understanding of the wiring diagram shown is necessary.

PRINCIPLE OF MUTING:

Anytime there is a break in the circuit due to the positions of an Input Selector Switch or a Channel Key Switch between the incoming drive signal on wire #208 and any of the outgoing control wires (#205, 206 or 207), muting will occur in that control area.

Thus, if there is a break between #208 and #206, this will cause Studio "A" to be muted since #206 is the control wire for Studio "A".

Primary selection of muting is done by the microphone selector switches. Since it is not necessary to have muting if the channel is not on the air, each microphone selector switch is in parallel with the AM-FM program selector switch. As soon as this switch is placed in either the AM or FM position, it opens and returns control to the mike selector switch.

Although these two switches are in parallel, it is important to note when you desire a given location to be muted by more than one mike position, you must series the desired locations as shown on the following page.

STUDIO "A" MUTING SCHEMATIC

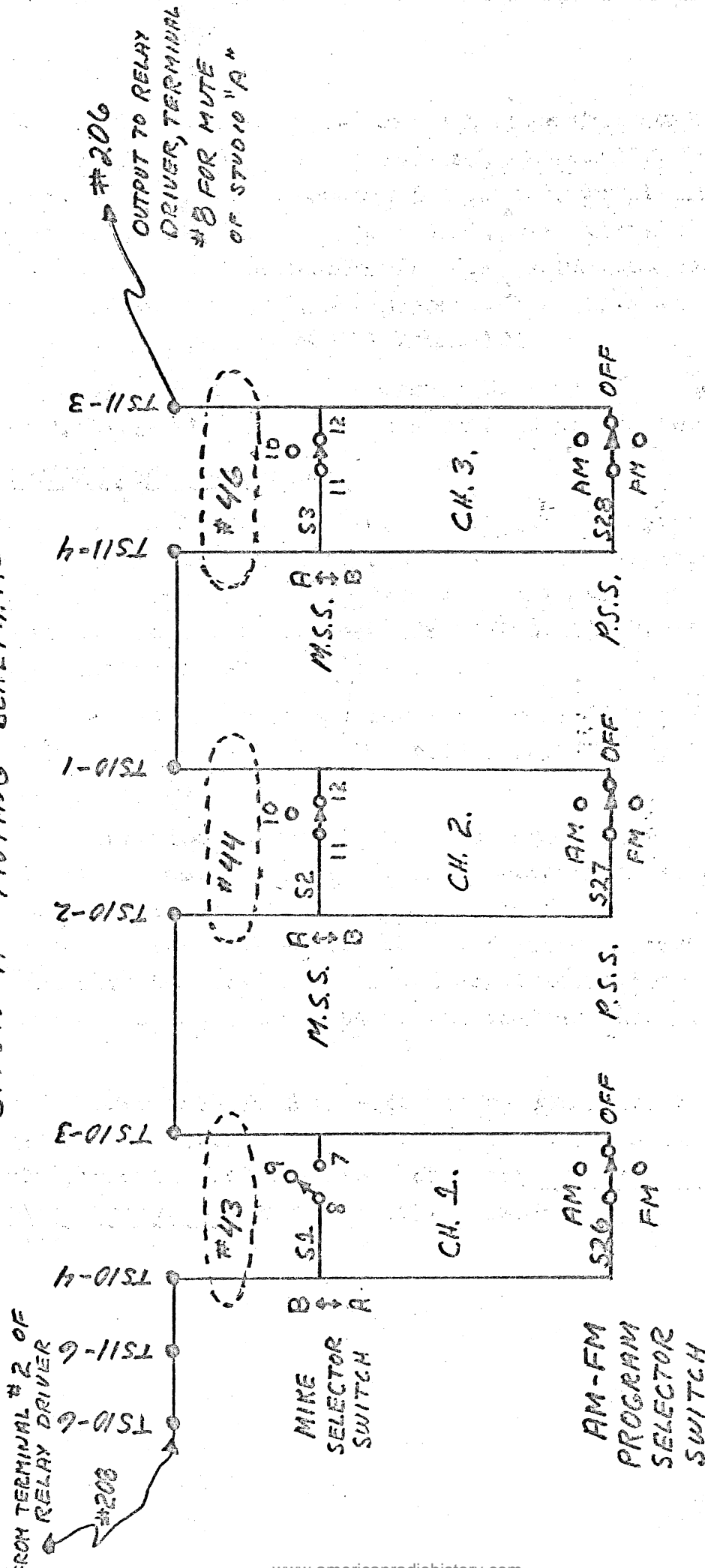

MIKE SELECTOR SWITCH CONDITION	PROGRAM SWITCH	AM & FM
CHANNEL 1	B	B
CHANNEL 2	B	B
CHANNEL 3	B	B
	OR	
CHANNEL 2	A	A
	OR	
CHANNEL 3	A	A

CHANNELS	1	2	3	4	5	6	7	8
NORMAL	150 OHM BAL (1)	150 OHM BAL	150 OHM BAL	150 OHM UNBAL	150 OHM UNBAL	150 OHM UNBAL	150 OHM UNBAL	600 OHM BAL
TYPE	MONO	MONO	STEREO/MONO	STEREO	STEREO	MONO	MONO	MONO
MAXIMUM INPUT LEVEL	-17 dBm*	-17 dBm*	-17 dBm*	-4 dBm**	-4 dBm**	-4 dBm**	-4 dBm**	+2 dBm**
NOMINAL INPUT LEVEL	-60 dBm	-60 dBm	-60 dBm	-20 dBm	-20 dBm	-20 dBm	-20 dBm	-14 dBm
SPECIAL IMPEDANCE	37.5 OHM (2) See preamp 1	37.5 OHM See preamp 2	37.5 OHM See preamp 3	AS REQUIRED	AS REQUIRED	AS REQUIRED	AS REQUIRED	200 OHM (3) 50 OHM See T1
REQUIRED MODI- FICATION	XFORMER <u>UNSOLDER</u> Red & Yellow Wire	XFORMER <u>UNSOLDER</u> Red & Yellow Wire	XFORMER <u>UNSOLDER</u> Red & Yellow Wire	PAD OR XFORMER	PAD OR XFORMER	PAD OR XFORMER	PAD OR XFORMER	200 OHM Change incoming wire from 1&3 to 1&2 50 OHM Change incoming wire from 1&3 to 2&3
	<u>SOLDER</u> Red to Blue Yellow to Brown	<u>SOLDER</u> Red to Blue Yellow to Brown	<u>SOLDER</u> Red to Blue Yellow to Brown					
	FOR NOTES, SEE NEXT PAGE.			TABLE I				DUALUX II

NOTES:

- * OVERLOAD POINT OF MICROPHONE PREAMP.
- ** END OF LINEAR PORTION OF LEVEL CONTROL (APPROXIMATELY 9 O'CLOCK).
- 1 NOMINAL INPUT IMPEDANCE OF 150 OHM WILL ACCOMMODATE 150 OHM TO 200 OHM MIKES.
- 2 NOMINAL INPUT IMPEDANCE OF 37.5 OHM WILL ACCOMMODATE 30 OHM TO 50 OHM MIKES.
- 3 NOMINAL INPUT IMPEDANCE OF 200 OHM WILL ACCOMMODATE 150 OHM TO 200 OHM SOURCES
AND 50 OHM NOMINAL IMPEDANCE WILL ACCOMMODATE 30 OHM TO 50 OHM SOURCES.

NOTE: The following chart may be used for H pads by halving R1 and making R101 equal to R1, and by halving R2 and making R102 equal to R2. For T pads, simply short out R101 and R102 and use R1 and R2 values directly.

LOSS PAD CHART

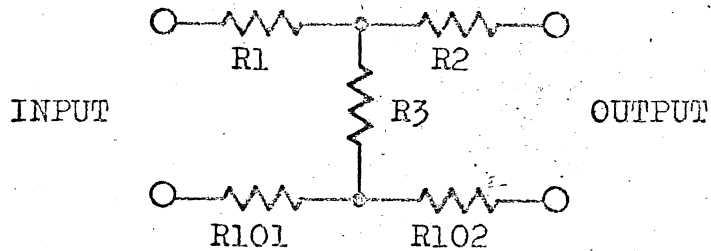

600/600 ohms "T" pads			150/150 ohms "T" pads		
db loss	R1-R2 ohms	R3 ohms	db loss	R1-R2 ohms	R3 ohms
2	68	2700	2	18	750
4	130	1200	4	36	330
6	200	820	6	51	200
8	270	510	8	62	120
10	330	390	10	82	100
15	430	220	15	110	56
20	470	120	20	120	30
25	510	68	25	130	16

600/150 ohms "T" pads			
db loss	R1 ohms	R2 ohms	R3 ohms
12 (min)	510	6.8	160
15	510	51	110
20	560	100	62
25	560	120	33

PARTS LIST

DUALUX II CONSOLE

994 6549 003 PREAMPLIFIER

<u>Symbol No.</u>	<u>Gates Part No.</u>	<u>Description</u>
C1,C6	522 0178 000	Cap., 25 uF., 6 V.
C2	522 0164 000	Cap., 250 uF., 3 V.
C3	522 0242 000	Cap., 25 uF., 25 V.
C4	500 0822 000	Cap., 75 pF., 500 V.
C5	522 0243 000	Cap., 35 uF., 25 V.
C7	516 0038 000	Cap., 330 pF., 1 kV.
C8	522 0387 000	Cap., 250 uF., 25 V.
C9	500 0807 000	Cap., 18 pF., 500 V.
Q1,Q2	380 0092 000	Transistor, 40319
Q3	380 0042 000	Transistor, 2N697
Q4	380 0044 000	Transistor, 40319
R1	540 1108 000	Res., 36K ohm, 1/2 W. 5%
R2	540 1106 000	Res., 6200 ohm, 1/2 W. 5%
R3	540 1107 000	Res., 20K ohm, 1/2 W. 5%
R4	540 1103 000	Res., 110 ohm, 1/2 W. 5%
R5	540 0042 000	Res., 510 ohm, 1/2 W. 5%
R6	540 0072 000	Res., 9100 ohm, 1/2 W. 5%
R7,R11	540 0049 000	Res., 1000 ohm, 1/2 W. 5%
R8	540 0060 000	Res., 3000 ohm, 1/2 W. 5%
R9	550 0300 000	Potentiometer, 750 ohm,
R10	540 1102 000	Res., 100 ohm, 1/2 W. 5%
R12	540 1104 000	Res., 2000 ohm, 1/2 W. 5%
R13	540 1105 000	Res., 5100 ohm, 1/2 W. 5%
R14,R15	540 0001 000	Res., 10 ohm, 1/2 W. 5%
R16	540 0018 000	Res., 51 ohm, 1/2 W. 5%
T1	478 0285 000	Transformer, Input
XQ1,XQ2	404 0066 000	Transistor Socket
XQ3,XQ4	404 0198 000	Transipad
Z1,Z2	414 0087 000	Ferrite Bead

PARTS LIST

994 6550 003 OUTPUT MODULE

<u>Symbol No.</u>	<u>Gates Part No.</u>	<u>Description</u>
Q5	380 0062 000	Transistor, 40310
Q6	380 0066 000	Transistor, 2N3740
XQ5,XQ6	404 0206 000	Power Transistor Socket

992 2225 001 OUTPUT AMPLIFIER

C1	522 0178 000	Cap., 25 uF., 6 V.
C2	522 0242 000	Cap., 25 uF., 25 V.
C3,C4,C5	522 0188 000	Cap., 250 uF., 6 V.
C6	500 0761 000	Cap., 150 pF., 500 V. 5%
C7	500 0755 000	Cap., 270 pF., 500 V. 5%
C8	516 0357 000	Cap., .1 uF., 75 V.
C9	522 0257 000	Cap., 35 uF., 50 V.
C10	500 0879 000	Cap., 2500 pF., 500 V. 5%
C11	516 0045 000	Cap., 500 pF., 1 kV.
Q1	380 0099 000	Transistor, 2N3391A
Q2	380 0053 000	Transistor, 40314
Q3	380 0050 000	Transistor, 40317
Q4	380 0044 000	Transistor, 40319
R1	540 0071 000	Res., 8.2K ohm, 1/2 W. 5%
R2	540 0075 000	Res., 12K ohm, 1/2 W. 5%
R3	540 0023 000	Res., 82 ohm, 1/2 W. 5%
R4	540 0072 000	Res., 9.1K ohm, 1/2 W. 5%
R5	540 0077 000	Res., 15K ohm, 1/2 W. 5%
R6	540 0334 000	Res., 1200 ohm, 1 W. 5%
R7,R22	540 0033 000	Res., 220 ohm, 1/2 W. 5%
R8	540 0028 000	Res., 130 ohm, 1/2 W. 5%
R9	559 0014 000	Thermistor, 500 ohm
R10,R12	550 0301 000	Potentiometer, 500 ohm
R11,R14, R15,R16	540 0029 000	Res., 150 ohm, 1/2 W. 5%
R13	540 0007 000	Res., 18 ohm, 1/2 W. 5%
R17,R18	542 1072 000	Res., .51 ohm, 2 W. 5%
R19	540 0045 000	Res., 680 ohm, 1/2 W. 5%
R20	540 0063 000	Res., 3900 ohm, 1/2 W. 5%
R21	540 0005 000	Res., 15 ohm, 1/2 W. 5%
XQ1,2,3,4	404 0198 000	Transipad

PARTS LIST

992 2224 001 BOOSTER AMPLIFIER

<u>Symbol No.</u>	<u>Gates Part No.</u>	<u>Description</u>
C1	522 0178 000	Cap., 25 uF., 6 V.
C2,C3	522 0167 000	Cap., 500 uF., 3 V.
C4	522 0242 000	Cap., 25 uF., 25 V.
C5	516 0054 000	Cap., .001 uF., 1 kV.
C6	522 0185 000	Cap., 100 uF., 6 V.
C7	522 0246 000	Cap., 100 uF., 25 V.
C8	516 0059 000	Cap., .0015 uF., 1 kV.
C9	500 0810 000	Cap., 24 pF., 500 V.
Q1,Q2	380 0092 000	Transistor, TN323
Q3	380 0042 000	Transistor, 2N697
R1	540 1131 000	Res., 30K ohm, 1/2 W. 5%
R2	540 1106 000	Res., 6200 ohm, 1/2 W. 5%
R3	540 1107 000	Res., 20K ohm, 1/2 W. 5%
R4	540 1110 000	Res., 68 ohm, 1/2 W. 5%
R5	540 0052 000	Res., 1300 ohm, 1/2 W. 5%
R6	540 0072 000	Res., 9100 ohm, 1/2 W. 5%
R7	540 0067 000	Res., 5600 ohm, 1/2 W. 5%
R8	540 1102 000	Res., 100 ohm, 1/2 W. 5%
R9	540 0049 000	Res., 1000 ohm, 1/2 W. 5%
R10	548 0171 000	Res., 11K ohm, 1/2 W. 5%
R11	540 0001 000	Res., 10 ohm, 1/2 W. 5%
R12	540 0051 000	Res., 1200 ohm, 1/2 W. 5%
R13	540 0044 000	Res., 620 ohm, 1/2 W. 5%
XQ1,XQ2	404 0066 000	Transistor Socket
XQ3	404 0198 000	Transipad
Z1,Z2	414 0087 000	Ferrite Bead

PARTS LIST

994 6551 002-30 V. REGULATED POWER SUPPLY

<u>Symbol No.</u>	<u>Gates Part No.</u>	<u>Description</u>
C1	522 0242 000	Cap., 25 uF., 25 V.
C2	522 0258 000	Cap., 50 uF., 50 V.
C3	516 0063 000	Cap., .002 uF., 1 kV.
CR1, CR2, CR3, CR4	384 0018 000	Diode, 1N2069
CR5	386 0019 000	Zener Diode, 6.8 V. 10%
CR6	386 0109 000	Zener Diode, 20 V. 10%, 1 W.
Q1, Q2	380 0062 000	Transistor, 40310
Q3	380 0044 000	Transistor, 40319
Q4	380 0042 000	Transistor, 2N697
R1	540 0071 000	Res., 8200 ohm, 1/2 W. 5%
R2	542 1105 000	Res., 2 ohm, 20 W. (WW)
R3	540 0045 000	Res., 680 ohm, 1/2 W. 5%
R4	540 0053 000	Res., 1500 ohm, 1/2 W. 5%
R5	540 0049 000	Res., 1000 ohm, 1/2 W. 5%
R6	550 0300 000	Potentiometer, 750 ohm
R7	540 0060 000	Res., 3000 ohm, 1/2 W. 5%
XQ1, XQ2	404 0206 000	Transistor Socket
XQ3, XQ4	404 0198 000	Transipad.
<u>994 6552 001 - 43V. REGULATED POWER SUPPLY</u>		
C1	522 0346 000	Cap., 500 uF., 50 V.
CR1, CR2 CR3, CR4	384 0018 000	Diode, 1N2069
CR5	386 0075 000	Diode, Zener, 1.5R43B
Q1, Q2	380 0062 000	Transistor, 40310
R1	540 0470 000	Res., 1500 ohm, 1 W. 10%
R2	542 1067 000	Res., 50 ohm, 5 W. 10%
R3	542 1105 000	Res., 2 ohm, 20 W. 5%
XQ1, XQ2	404 0206 000	Transistor Socket
<u>994 6553 001 - MUTING MODULE</u>		
Q1, Q2, Q3	914 5419 001	Transistor, Special Tested
R1, R2, R3	542 1102 000	Res., 1000 ohm, 5 W. 10%
XQ1, XQ2, XQ3	404 0206 000	Power Transistor Socket

PARTS LIST
BASIC DUALUX II CONSOLE

<u>Symbol No.</u>	<u>Gates Part No.</u>	<u>Description</u>
	650 0134 000	Knob, Red (Lever Sw.)
	650 0129 000	Knob, Black (Lever Sw.)
	650 0133 000	Top Hat Knob, Red
	650 0128 000	Top Hat Knob, Black
	650 0130 000	Attenuator Knob
	648 0045 000	Dial Dish
A1, A2	396 0161 000	Lamp, 28 V.
A3 thru A8	396 0120 000	Lamp, 28 V.
AT1, AT2	554 0188 000	Attenuator, 150/300 ohm
AT3	554 0281 000	Attenuator, Dual, 150/300 ohm
AT4, AT5	554 0280 000	Attenuator, Dual, 150/300 ohm, w/cue
AT6, AT7, AT8	554 0182 000	Attenuator, 150/300 ohm, w/cue
AT9	550 0282 000	Cue Gain Pot., 10K ohm, 1/2 W.
AT10	550 0283 000	Monitor Pot., Dual, 10K ohm, 1/2 W.
AT11, AT12, AT13	550 0284 000	Master Gain Pot., 10K ohm, 1/2 W.
C1, C2, C3, C5, C6	524 0113 000	Cap., 2500 uF., 50 V.
C4	522 0257 000	Cap., 35 uF., 50 V.
C7, C8, C9, C10	524 0123 000	Cap., 1000 uF., 75 V.
Qty. (1)	522 0242 000	Cap., 25 uF., 25 V.
(1)	516 0043 000	Cap., 470 pF., 1 kV, 10%
(2)	516 0386 000	Cap., .22 uF., 3 V.
(1)	516 0393 000	Cap., .025 uF., 200 V. 20%
(8)	516 0081 000	Cap., .01 uF., 1 kV, 20%
(4)	526 0004 000	Cap., 1 uF., 35 V. 10%
(1)	526 0014 000	Cap., 22 uF., 15 V. 10%
(1)	508 0287 000	Cap., .22 uF., 100 V. 10%
(1)	508 0210 000	Cap., .015 uF., 100 V. 10%
(1)	508 0291 000	Cap., .008 uF., 600 V. 10%
(1)	516 0076 000	Cap., .0056 uf., 1 KV.
CR1	384 0018 000	Diode, 1N2069
F1, F2	398 0011 000	Fuse, 1/4 A. 250 V.
EQ1, EQ2, EQ3	992 2123 001	Equalizer Pad
J1	612 0280 000	Phone Jack
K1	574 0103 000	Relay, 4PDT, 24 VDC plug-in
	494 0114 000	R.F. Choke, 1 mH.

PARTS LIST

BASIC DUALUX II CONSOLE (Cont.)

<u>Symbol No.</u>	<u>Gates Part No.</u>	<u>Description</u>
LS1	722 0049 000	Cue Speaker
M1, M2, M3	630 0121 000	VU Meter
P1, thru P23	612 0428 000	Printed Circuit Connector
Qty. 4	540 0060 000	Res., 3000 ohm 1/2 W 5%
5	540 0043 000	Res., 560 ohm 1/2 W 5%
2	540 0025 000	Res., 100 ohm 1/2 W 5%
5	540 0036 000	Res., 300 ohm 1/2 W 5%
13	540 0029 000	Res., 150 ohm 1/2 W 5%
11	540 0035 000	Res., 270 ohm 1/2 W 5%
2	540 0074 000	Res., 11 K ohm 1/2 W 5%
11	540 0044 000	Res., 620 ohm 1/2 W 5%
2	540 0056 000	Res., 2000 ohm 1/2 W 5%
1	540 0018 000	Res., 51 ohm 1/2 W 5%
16	540 0066 000	Res., 5100 ohm 1/2 W 5%
1	540 0059 000	Res., 2700 ohm 1/2 W 5%
2	540 0300 000	Res., 47 ohm 1 W 5%
2	540 0607 000	Res., 680 ohm 2 W 5%
2	542 0061 000	Res., 150 ohm 10W Pigtail Leads
1	540 0071 000	Res., 8200 ohm 1/2 W 5%
1	540 0032 000	Res., 200 ohm 1/2 W 5%
1	540 0039 000	Res., 390 ohm, 1/2 W. 5%
2	540 0061 000	Res., 3300 ohm, 1/2 W. 5%
S1, S2, S4, thru S20	602 0007 000	Lever Sw., 4 pole 2 pos.
S3	602 0060 000	Lever Sw., 6 pole 2 pos.
S21 thru S25, S39 thru S42	602 0005 000	Lever Sw., 2 pole 3 pos.
S31, S32, S33	602 0064 000	Lever Sw., 3 Pos w/28V Lamp
S26 thru S30	602 0063 000	Lever Sw., 3 pos w/28V Lamp
S34, S35	914 8509 003	Selector Sw., 2 pole 5 pos. (Mod.)
S36	914 8509 001	Selector Sw., 4 pole 11 pos. (Mod.)
S37	604 0349 000	Multi-slide sw.
S38	604 0230 000	Red Pushbutton Sw.
T1, T9	478 0009 000	Line Transformer-A21 UTC
T5, T6, T7	478 0276 000	Program Output Transformer
T8	478 0274 000	Remote Cue Transformer
TB1	614 0484 000	Term. Block, 80 Term.
TB2	614 0483 000	Term. Block, 40 Term.
TB3	614 0034 000	Term. Board
	406 0381 000	Lamp Socket
XK1	404 0160 000	Relay Socket
XF1, XF2	402 0024 000	Fuseholder

PARTS LIST

994-6556-003 TRANSFORMER PANEL

<u>Symbol No.</u>	<u>Gates Part No.</u>	<u>Description</u>
C1,C2	516 0087 000	Cap., .05 uf., 600 V.
CB1, CB2	606 0116 000	Circuit Breaker
CR1 thru CR6	384 0018 000	Diode, 1N2069
F1, F2, F3, F4	398 0326 000	Fuse, 1 A, Visual Indicating
K1, K2, K3	574 0140 000	Relay, 2500 ohm
T1, T2	472 0570 000	Power Transformer
T3, T4	472 0569 000	Power Transformer
TB1, TB2	614 0010 000	Terminal Board
XF1, XF2, XF3, XF4	402 0103 000	Fuseholder

RIGHT MIXING BUS - 992 1877 001

R21, R24, R27, R31, R35	540 0036 000	Res., 300 ohm, 1/2 W. 5%
R22, R23, R25, R26, R28, R29, R30, R32, R33, R34, R36, R37, R38	540 0044 000	Res., 620 ohm, 1/2 W. 5%

LEFT MIXING BUS - 992 1878 001

R1, R5, R9, R12, R15, R18	540 0036 000	Res., 300 ohm, 1/2 W. 5%
R2, R3, R4, R6, R7, R8, R10, R11, R13, R14, R16, R17, R19, R20	540 0044 000	Res., 620 ohm, 1/2 W. 5%
T2, T3, T4	478 0285 000	Input Transformer

METER PAD BOARD - 992 1880 001

R1, R5, R10	540 0056 000	Res., 2000 ohm, 1/2 W. 5%
R2, R7, R9	540 0060 000	Res., 3000 ohm, 1/2 W. 5%
R3, R6, R8	540 0067 000	Res., 5600 ohm, 1/2 W. 5%
R4	540 0063 000	Res., 3900 ohm, 1/2 W. 5%
S1	604 0348 000	Switch Slide, DPDT

PARTS LIST

PAD BOARD - 992 1879 001

<u>Symbol No.</u>	<u>Gates Part No.</u>	<u>Description</u>
C3,C6,C7	508 0215 000	Cap., .01 uf., 100 V. 10%
C4	516 0362 000	Cap., .0012 uf., 500 V. 10%
C5	516 0370 000	Cap., .005 uf., 500 V. 10%
C1,C2	526 0004 000	Cap., 1 uf., 35 V. 10%
R1,R8,R15	540 0050 000	Res., 1100 ohm, 1/2 W. 5%
R2,R7,R16	540 0053 000	Res., 1500 ohm, 1/2 W. 5%
R3,R6	540 0089 000	Res., 47K ohm, 1/2 W. 5%
R4	540 0071 000	Res., 8200 ohm, 1/2 W. 5%
R5,R14	540 0060 000	Res., 3000 ohm, 1/2 W. 5%
R9,R10,R12,R13, R17,R18,R20,R21, R22,R23,R25,R26	540 0025 000	Res., 100 ohm, 1/2 W. 5%
R11,R19,R24	540 0047 000	Res., 820 ohm, 1/2 W. 5%

EQUALIZER PAD - 992 2123 001

C1	508 0077 000	Cap., .0033 uf., 600 V. 10%
C2	526 0012 000	Cap., 3.9 uf., 35 V. 10%
R1	540 0059 000	Res., 2700 ohm, 1/2 W. 5%
R2,R3	540 0056 000	Res., 2000 ohm, 1/2 W. 5%
R4	540 0036 000	Res., 300 ohm, 1/2 W. 5%

Speaker matching transformer information using Gates 478 0275 000 auto-transformer. Shown below are some typical installations.

(A) Lobby speakers, 8 or 16 ohms.

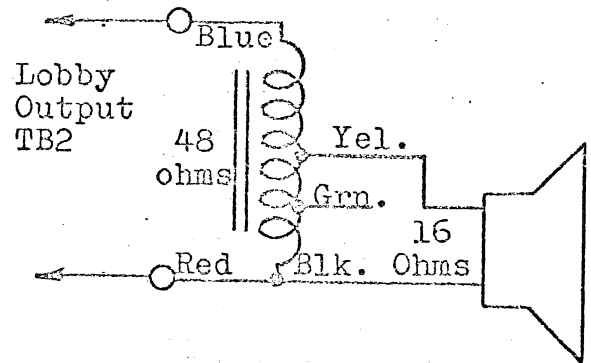
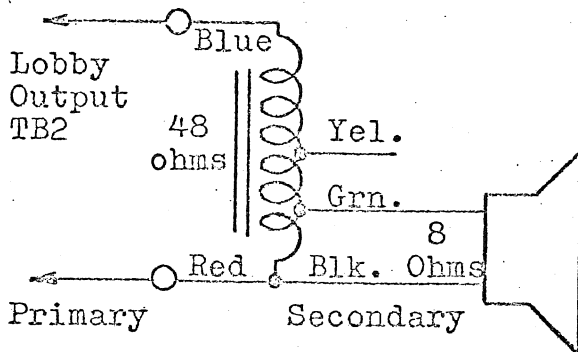

(B) Muted outputs, using 8 and 16 ohm speakers.

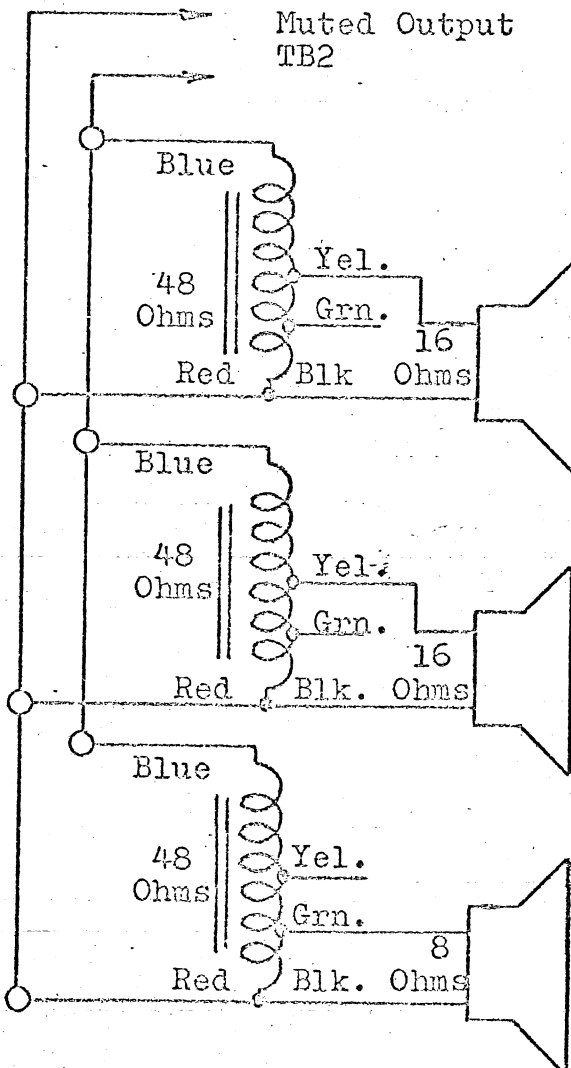

(C) Amplifier Loading

The load impedance of the monitor amplifier is 8 ohms. Speaker loads of 4 to 16 ohms may be used. Loading the amplifier lower than 4 ohms may damage the unit. Some suggested loads are listed below.

- 1 - One 8 ohm speaker.
- 2 - Two 16 ohm speakers connected in parallel.
- 3 - From one to six speakers using Gates 478 0275 000 speaker matching transformers.

NOTES:

1. PIN CONNECTIONS COMPONENTS SIDE, LEFT TO RIGHT.
2. CAPACITORS IN MFD. WITH D.C. RATING.
3. COMPONENT VALUES SHOWN ARE NOMINAL VALUES. SLIGHT CHANGES MAY BE NECESSARY TO COMPENSATE FOR PRODUCTION TOLERANCES
4. C2 IS EXTERNALLY MOUNTED.

- 1.- C2 OUTPUT GND.
- 2.- C2 INPUT GND.
- 3.- 36VAC
- 4.- N.C
- 5.- 36V AC
- 6.- C2 B+ CONNECTION
- 7.- DC. GND.
8. REGULATED
9. 43V D.C.

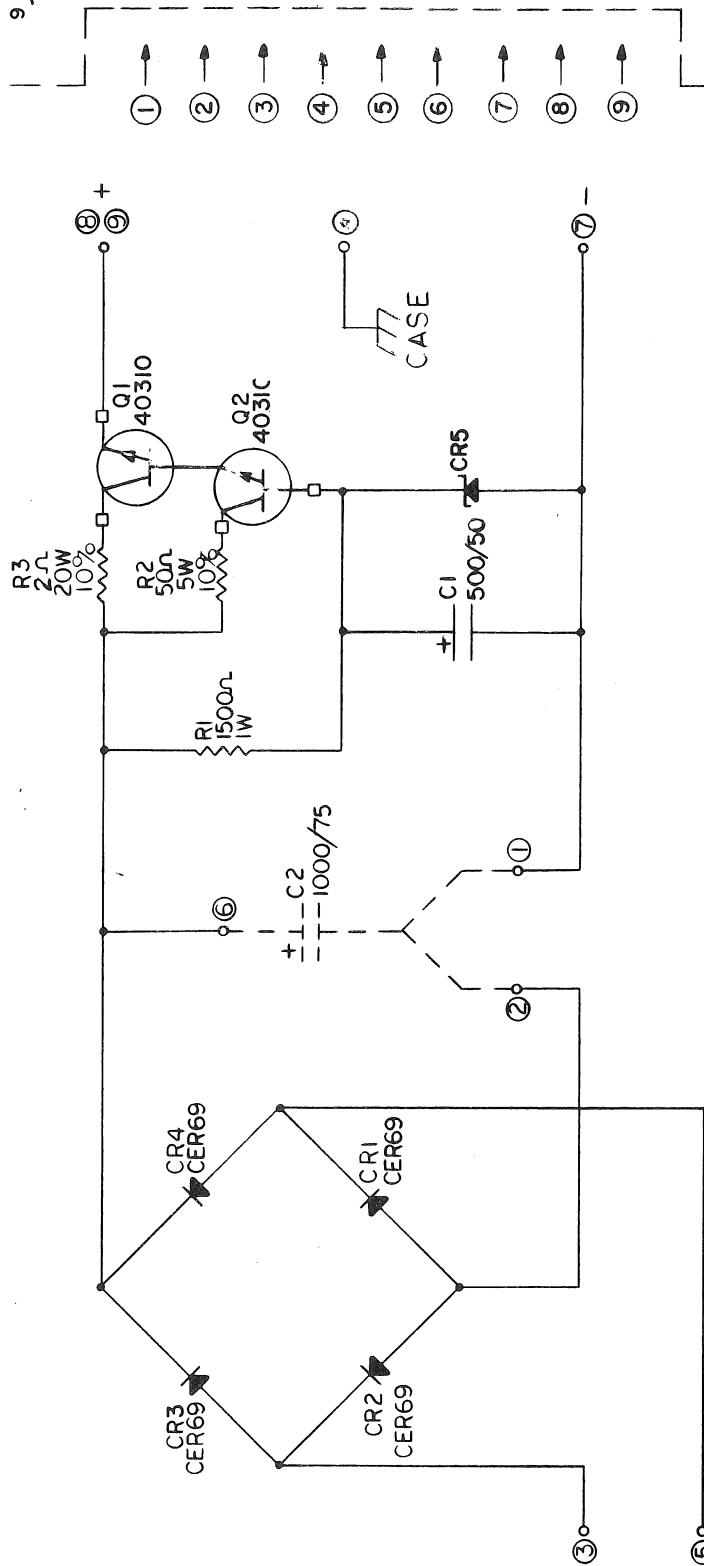

GE Replacement # on
2N4400TAN10701K - GE-20

1. PIN CONNECTIONS COMPONENTS SIDE, LEFT TO RIGHT.
2. ALL RESISTORS 1/2 WATT 5%, ★ DENOTES LOW NOISE.
3. CAPACITORS IN MFD WITH D.C. RATING, UNLESS SPECIFIED.
4. COMPONENT VALUES SHOWN ARE NOMINAL VALUES. SLIGHT CHANGES MAY BE NECESSARY TO COMPENSATE FOR PRODUCTION TOLERANCES.
5. THE BOOSTER AMPLIFIER IS PHYSICALLY LOCATED IN THE EXTRUDED HOUSING OF THE OUTPUT MODULE.
6. D.C. VOLTAGES ARE NOMINAL, MEASURED WITH A VTVM, NO SIGNAL.
7. VOLTAGES IN (V) ARE SIGNAL LEVELS FOR +8DBM(600Ω) OUTPUT, 1000HZ.

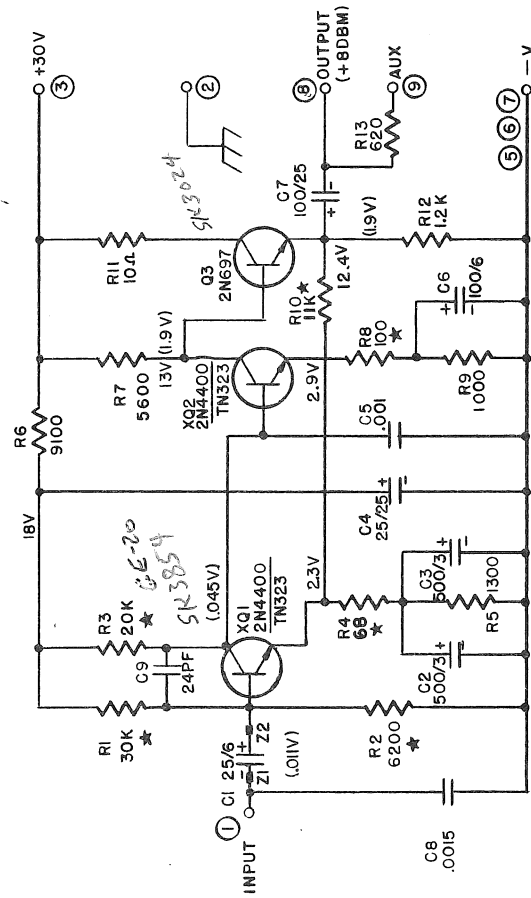
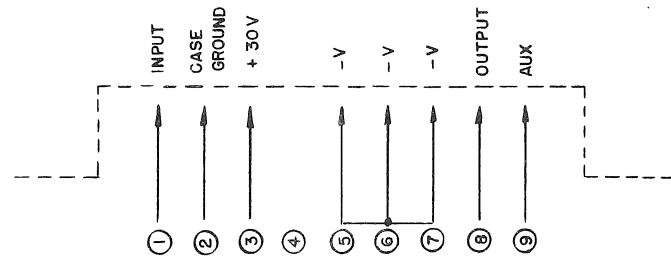

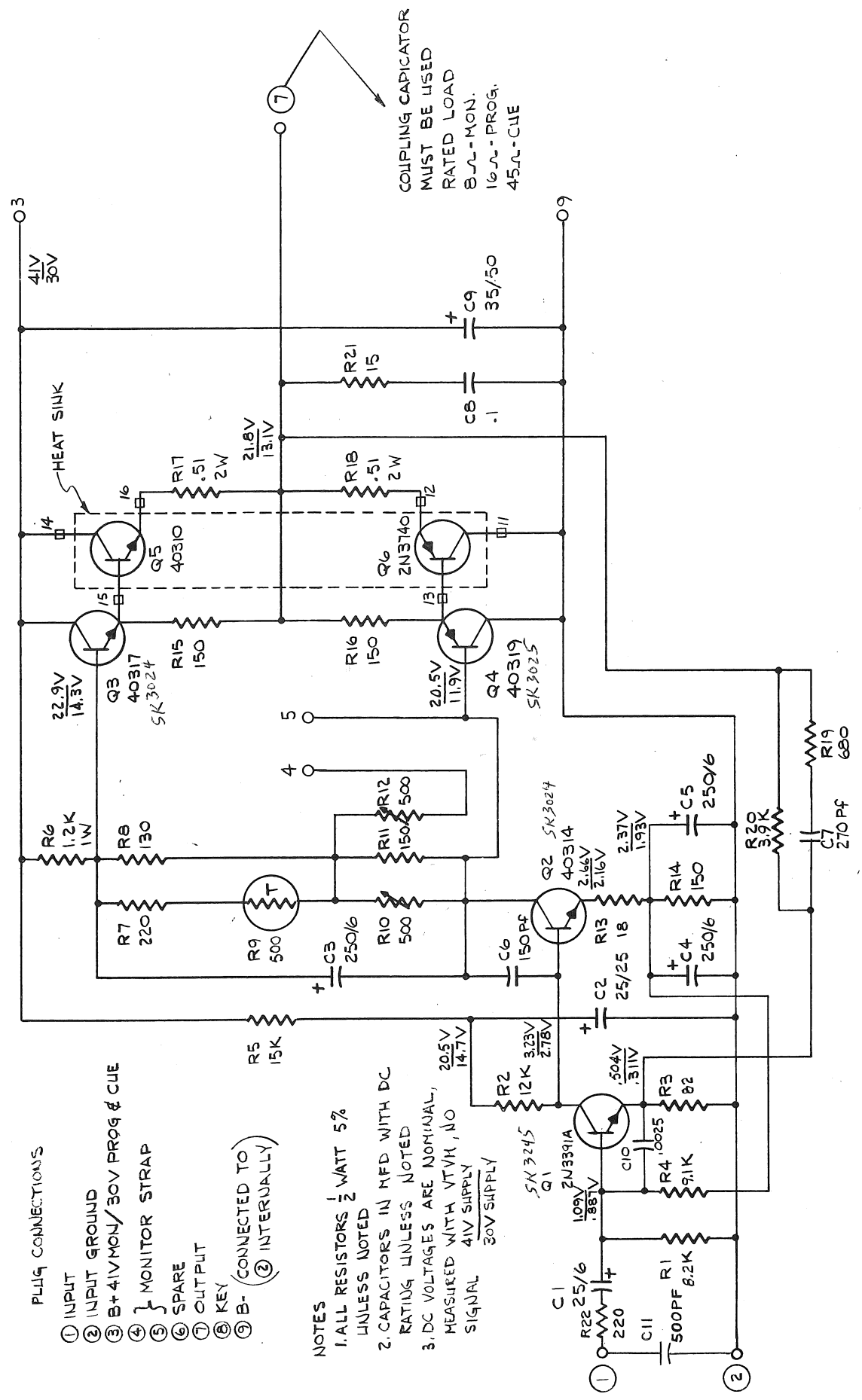

PLUG CONNECTIONS

- ① INPUT
- ② INPUT GROUND
- ③ B+ 41V MON/30V PROG & CUE
- ④ } MONITOR STRAP
- ⑤ SPARE
- ⑥ SPARE
- ⑦ OUTPUT
- ⑧ KEY
- ⑨ B- (CONNECTED TO ② INTERNALLY)

NOTES

- 1. ALL RESISTORS 1/2 WATT 5% UNLESS NOTED
- 2. CAPACITORS IN MFD WITH DC RATING UNLESS NOTED
- 3. DC VOLTAGES ARE NOMINAL, MEASURED WITH VTVM, NO SIGNAL

SCHMATIC PROGRAM-MONITOR-CUE AMP.

NOTES:

1. SINGLE SOLID STATE MUTING MODULE IS COMPOSED OF ONE BOARD IN ONE EXTRUSION ASS'Y. (M6553A)
2. DOUBLE SOLID STATE MUTING MODULE IS COMPOSED OF TWO BOARDS IN ONE EXTRUSION ASS'Y. (M6553B)
3. +33VOLTS IS APPLIED TO TURN ON THE MUTING DEVICE, TO TURN OFF, VOLTAGE IS REMOVED.
4. CURRENT PER MUTING DEVICE IS 50 *ma.* MAX.
5. COMPONENT VALUES SHOWN ARE NOMINAL VALUES. SLIGHT CHANGES MAY BE NECESSARY TO COMPENSATE FOR PRODUCTION TOLERANCES.

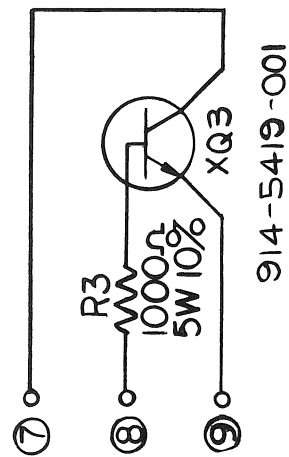
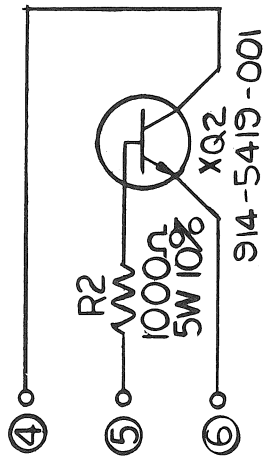
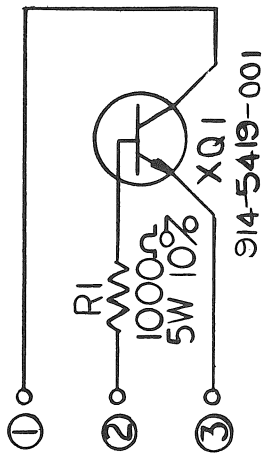
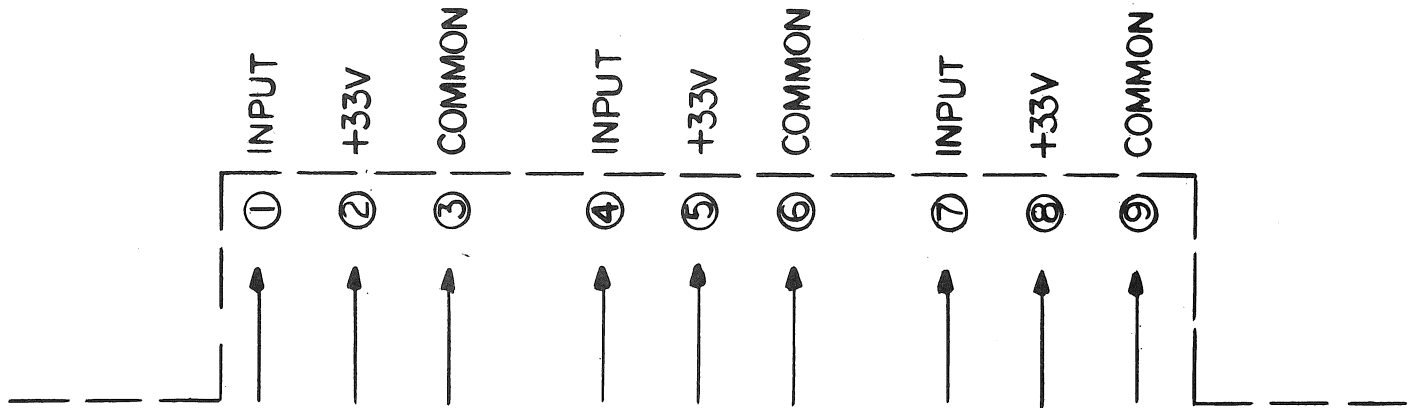

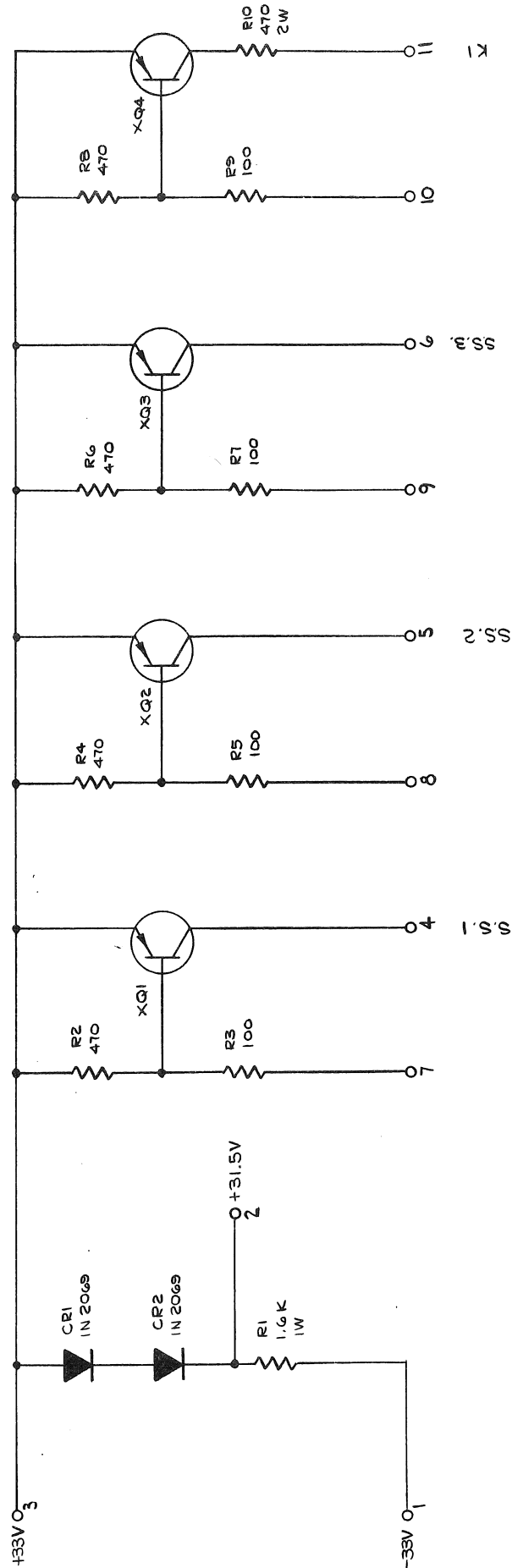

ALL TRANSISTORS 40319

SCHEMATIC - DRIVERS FOR SS. MUTING AND RELAY DUALUX II GATESWAY II 94479-1

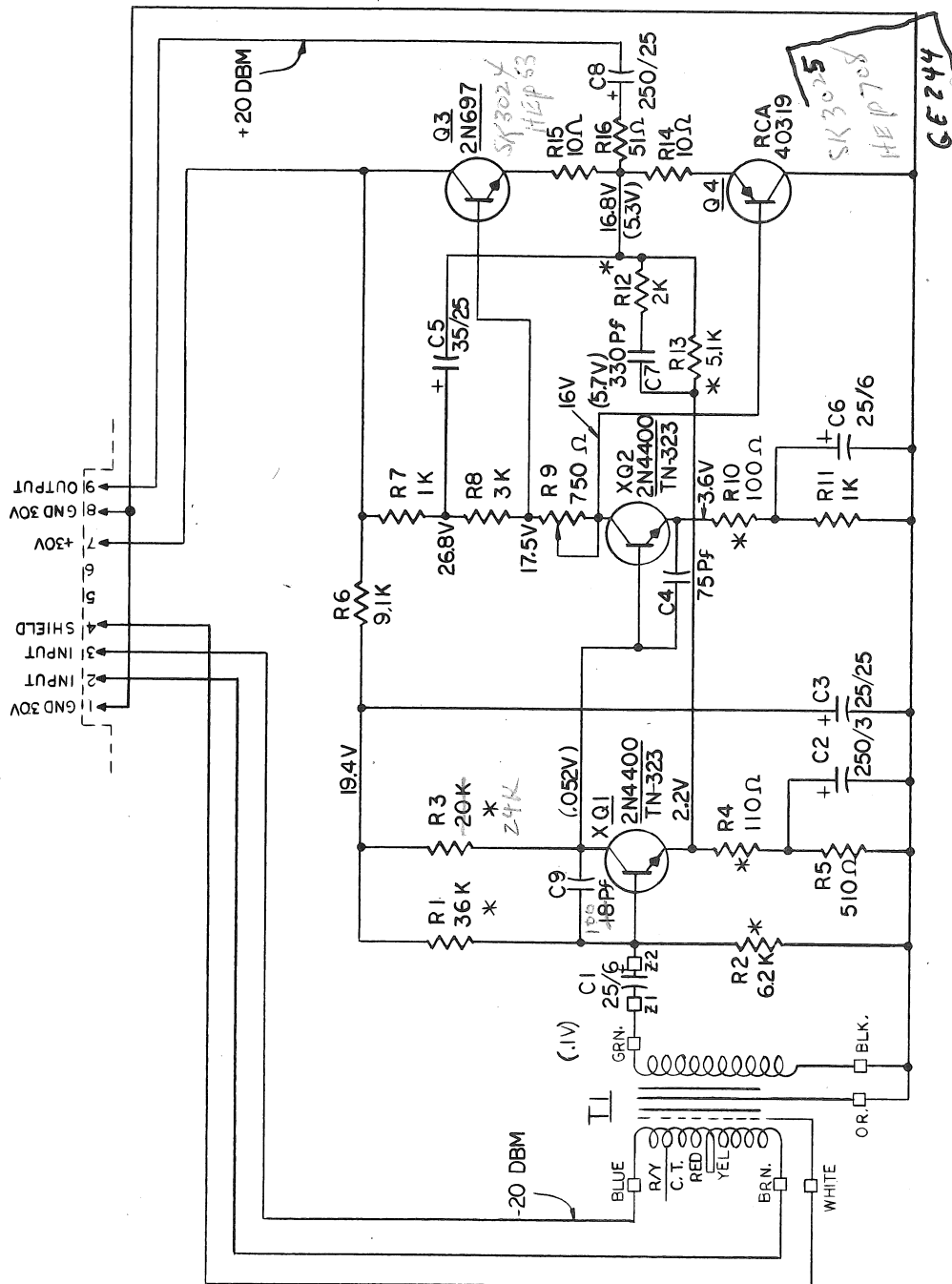

NOTES:

1. PIN CONNECTIONS COMPONENTS SIDE, LEFT TO RIGHT.
2. ALL RESISTORS 1/2 WATT 5%
3. CAPACITORS IN MFD WITH DC. RATING, UNLESS SPECIFIED.
4. * DENOTES LOW NOISE RESISTORS.
5. COMPONENT VALUES SHOWN ARE NOMINAL VALUES. SLIGHT CHANGES MAY BE NECESSARY TO COMPENSATE FOR PRODUCTION TOLERANCES.
6. D.C. VOLTAGES ARE NOMINAL, MEASURED WITH A VTVM, NO SIGNAL.
7. VOLTAGES IN (V) ARE SIGNAL LEVELS FOR +20DBM (150Ω) OUTPUT, 1000HZ

TI PRIMARY CONNECTIONS

IMP	CT	JOIN	CONNECT TO
37.5Ω	R/Y	REDEBLUE	BLUE & YEL.
150Ω	—	YEL & RED	BLUE & BRN.

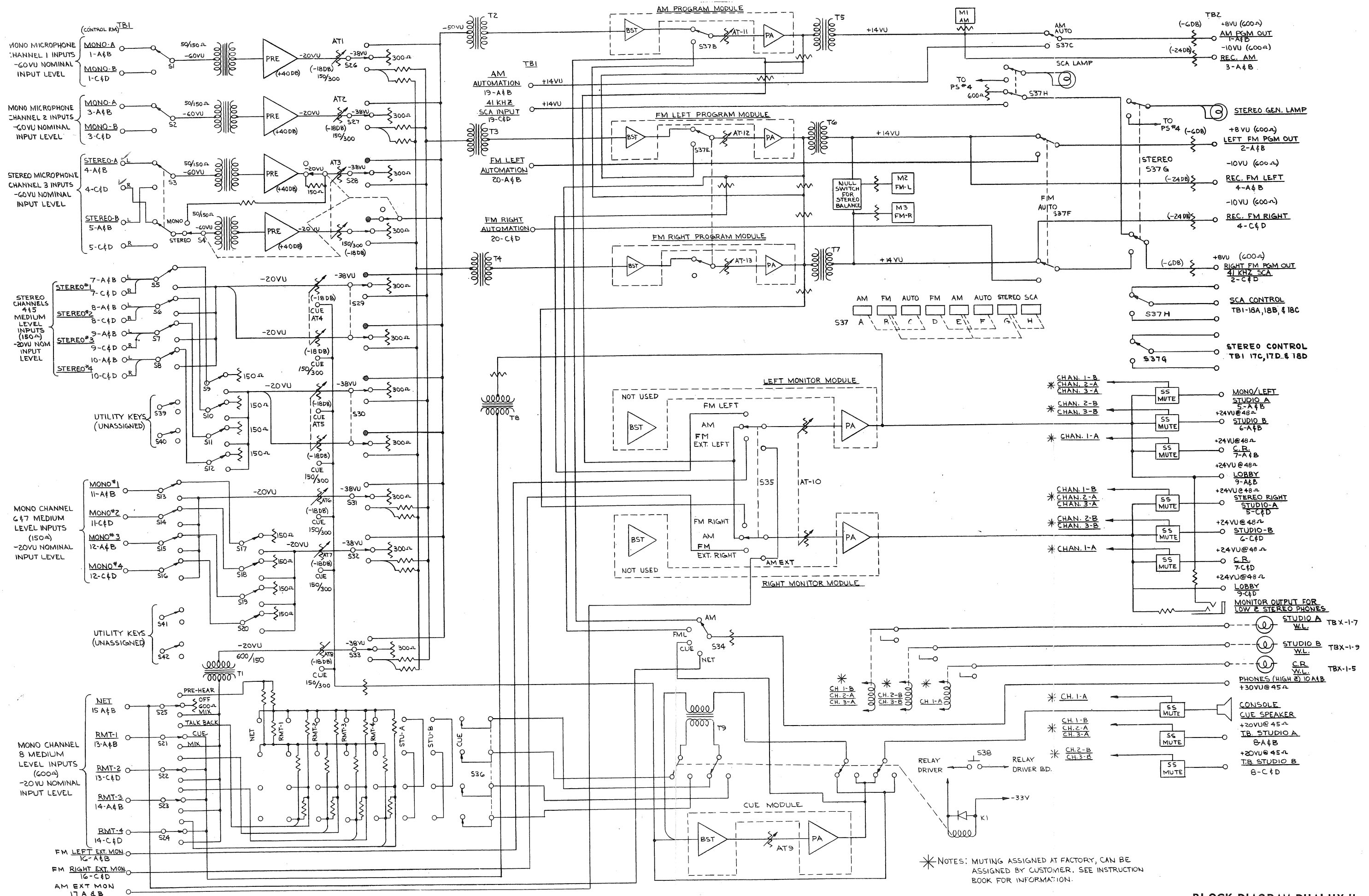

*NOTES: MUTING ASSIGNED AT FACTORY, CAN BE ASSIGNED BY CUSTOMER. SEE INSTRUCTION BOOK FOR INFORMATION.

BLOCK DIAGRAM DUALUX II
842 4989 001

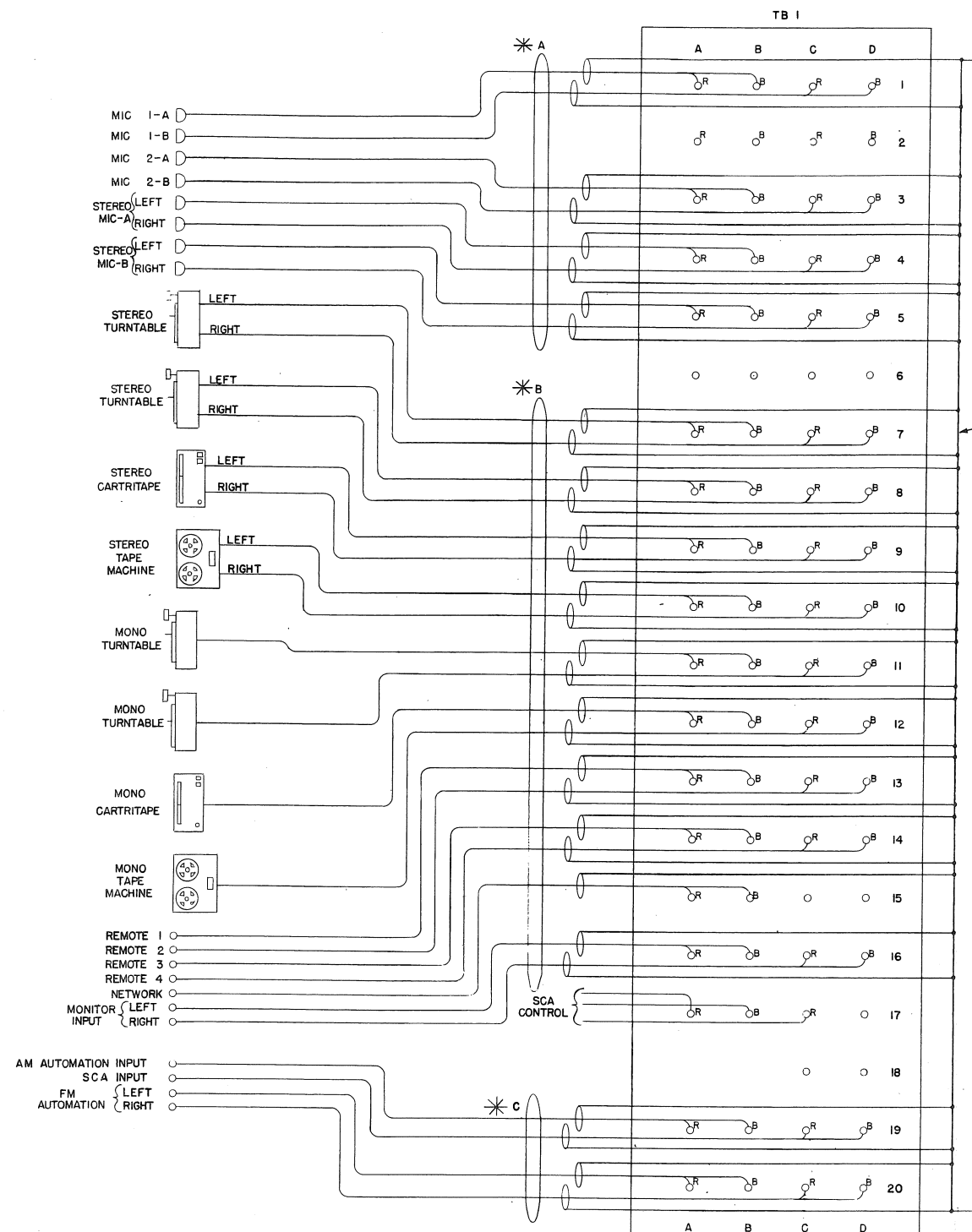

* INDICATES DIFFERENT CABLE LEVELS
 "A" CABLE — MICS -60VU
 "B" CABLE — -60 TO -20VU
 "C" CABLE — -20 TO +20VU
 "D" CABLE — +20 TO +40VU

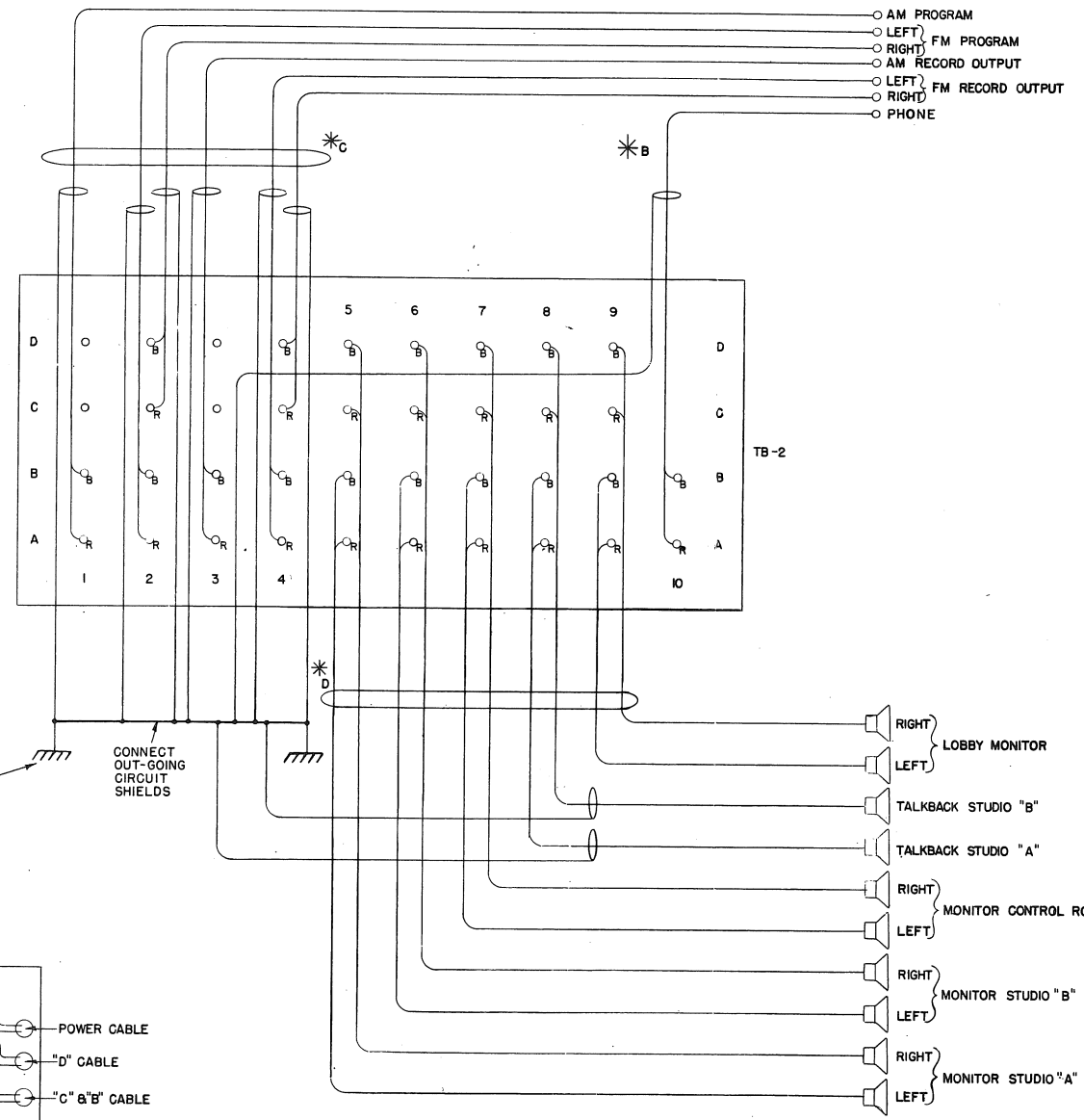
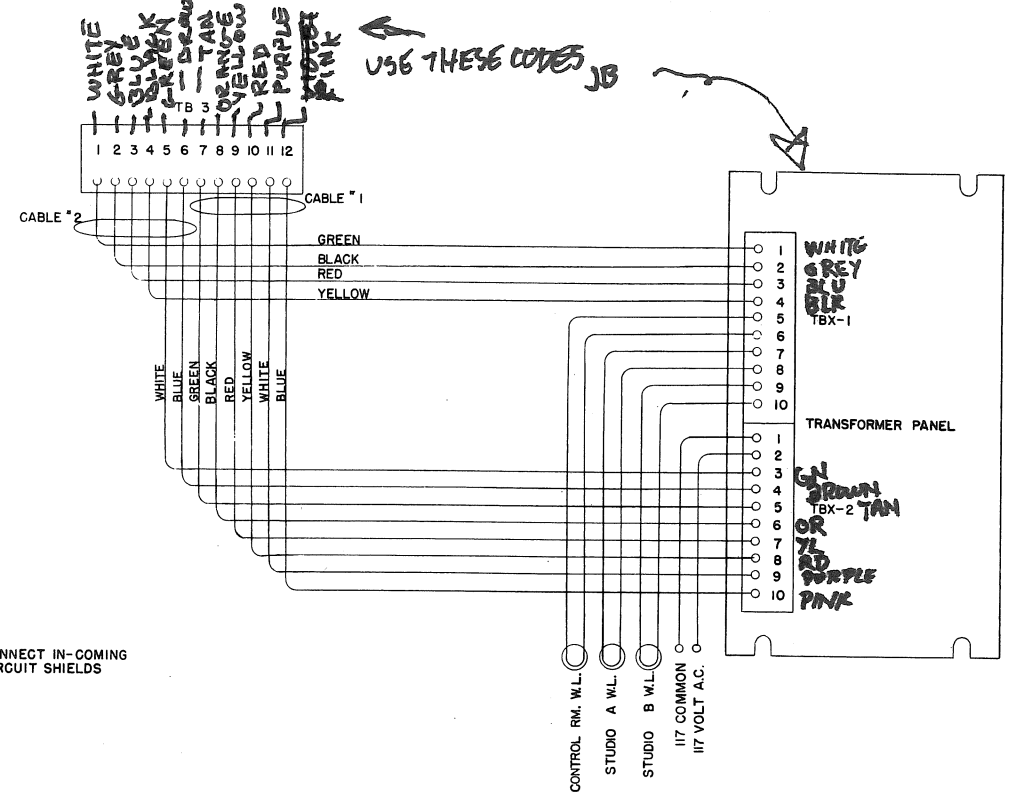
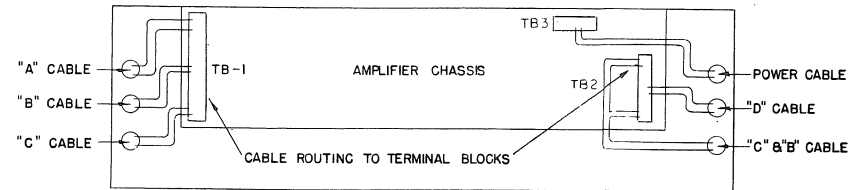

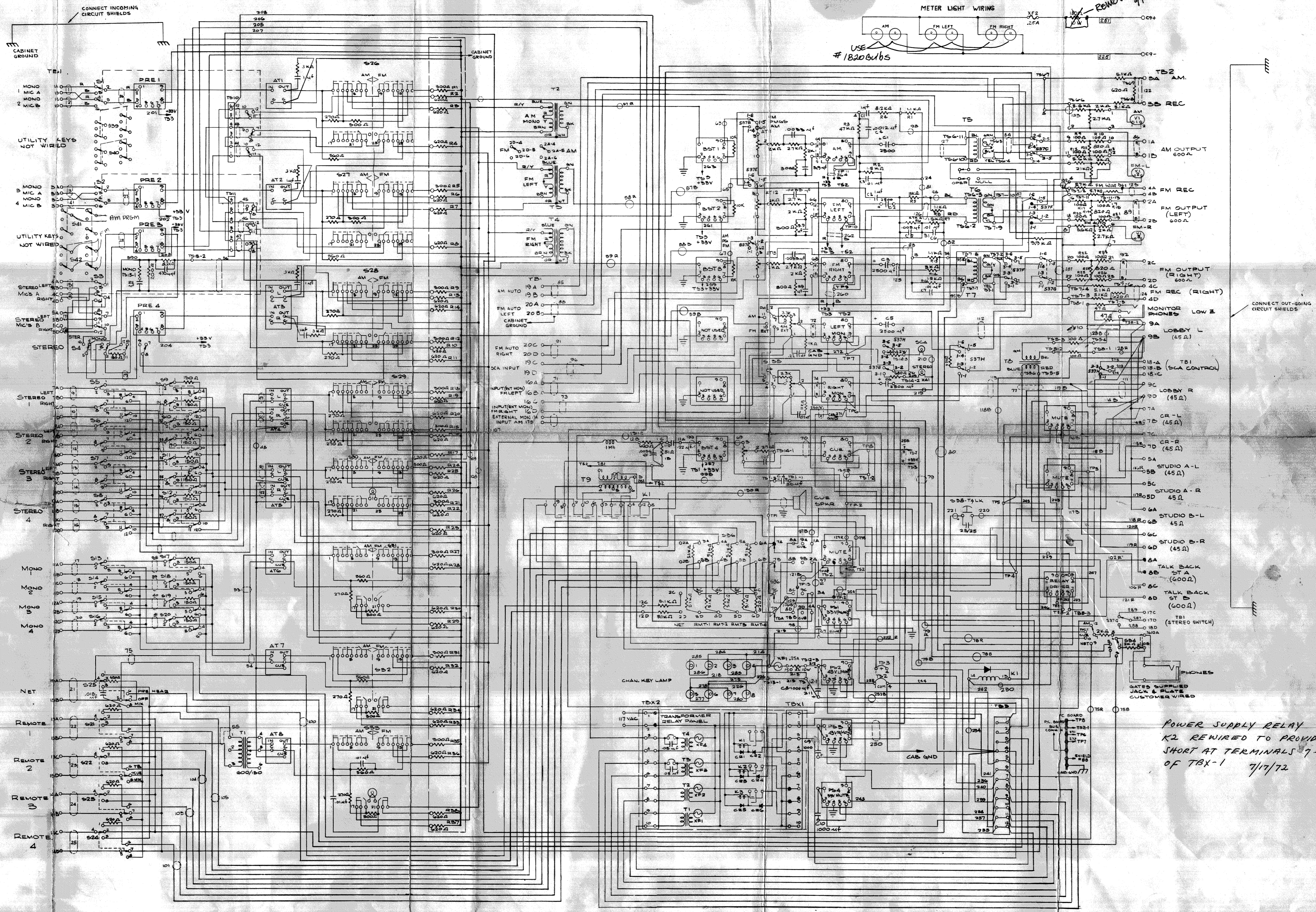

METER LIGHT WIRING
 USE #18206bubs
 XFE .25A
 XW
 251
 0C9+
 225
 0C9-

REMOVED 3/1/83

POWER SUPPLY RELAY
 K2 REWIRED TO PROVIDE
 SHORT AT TERMINALS 7-8
 OF TBX-1 7/17/72

**HOME OFFICE AND
MANUFACTURING FACILITIES**

QUINCY, ILLINOIS 62301
123 Hampshire Street
Phone: 222-8200, Area 217

SOUTHWEST SERVICE CENTER

HOUSTON, TEXAS 77027
4019 Richmond Avenue
Phone: 666-4333, Area 713

DISTRICT OFFICES

NEW YORK, NEW YORK 10017
800 Second Avenue
Phone: 687-7971, Area 212

WASHINGTON, D. C. 20005
730 Federal Building
1522 K Street, N.W.
Phone: 223-5508, Area 202

LOS ANGELES, CALIFORNIA 90007
1945 South Figueroa
Phone: 747-7129, Area 213

CANADIAN SALES

GATES RADIO COMPANY (CANADA)
Division of Harris-Intertype (Canada) Ltd.

Montreal Office
212 Brunswick Boulevard
Pointe-Claire, Quebec, Canada
Phone: 695-3751, Area 514

Toronto Office
19 Lesmill Road
Don Mills, Ontario, Canada
Phone: 447-7234, Area 416

**HARRIS
INTERTYPE
CORPORATION**

GATES[®]

GATES RADIO COMPANY
A Division of Harris-Intertype Corporation
QUINCY, ILLINOIS, 62301 U.S.A.