

TECHNICAL MANUAL

MW-50C3 MEDIUM WAVE

AM BROADCAST TRANSMITTER

994 8832 004



T.M. No. 888-2213-011

Printed: October 2, 1986

© Copyright HARRIS CORPORATION
1986 All Rights Reserved

MANUAL REVISION HISTORY
MW-50C3 MEDIUM WAVE AM BROADCAST TRANSMITTER
888-2213-xxx

REV #	DATE	ECN	PAGES AFFECTED
002	10-10-85	29595	Replaced the following pages: Title Page, 9-3/9-4 Added the following page: Manual Revision History Page
003	2-5-86	29673	Replaced the following pages: Title Page, i, ii, iii, 6-2, 7-1, 7-40 Manual Revision History Page
004	2-6-86	29816	Replaced the following pages: Title Page, 7-39 Manual Revision History Page
005	2-7-86	29830	Replaced the following pages: Title Page, 7-8, 7-9, 9-13/9-14 Manual Revision History Page
006	3-15-86	29922	Replaced the following pages: Title Page, 1-2, 7-5 Manual Revision History Page
007 & 008	7-01-86	30077, 30189,& 30627	Replaced the following pages: Title Page, Manual Revision History Page 2-33, 7-2, 7-3, 7-7, 7-8, 7-9, 7-10, 7-16, 7-40, 7-47, 8-25/8-26, 8-27/8-28, 9-3/9-4, 9-9/9-10, 9-15/9-16 Added pages 7-48 & 7-49/7-50
009	8-15-86	30805	Replaced the following pages: Title Page, Manual Revision History Page 2-1, 2-44, 2-47, 2-48, 2-50, 2-51, 2-53, 6-9 & 6-10
010	9-08-86	30891	Replaced the following pages: Title Page, Manual Revision History Page 7-13 & 7-16
011	10-02-86	31083	Replaced the following pages: Title Page, Manual Revision History Page 4-32

WARNING

THE CURRENTS AND VOLTAGES IN THIS EQUIPMENT ARE DANGEROUS.
PERSONNEL MUST AT ALL TIMES OBSERVE SAFETY REGULATIONS.

This manual is intended as a general guide for trained and qualified personnel who are aware of the dangers inherent in handling potentially hazardous electrical/electronic circuits. It is not intended to contain a complete statement of all safety precautions which should be observed by personnel in using this or other electronic equipment.

The installation, operation, maintenance and service of this equipment involves risks both to personnel and equipment, and must be performed only by qualified personnel exercising due care. HARRIS CORPORATION shall not be responsible for injury or damage resulting from improper procedures or from the use of improperly trained or inexperienced personnel performing such tasks.

During installation and operation of this equipment, local building codes and fire protection standards must be observed. The following National Fire Protection Association (NFPA) standards are recommended as references:

- Automatic Fire Detectors, No. 72E
- Installation, Maintenance, and Use of Portable Fire Extinguishers, No. 10
- Halogenated Fire Extinguishing Agent Systems, No. 12A

WARNING

ALWAYS DISCONNECT POWER BEFORE OPENING COVERS, DOORS, ENCLOSURES, GATES, PANELS OR SHIELDS. ALWAYS USE GROUNDING STICKS AND SHORT OUT HIGH VOLTAGE POINTS BEFORE SERVICING. NEVER MAKE INTERNAL ADJUSTMENTS, PERFORM MAINTENANCE OR SERVICE WHEN ALONE OR WHEN FATIGUED.

Do not remove, short-circuit or tamper with interlock switches on access covers, doors, enclosures, gates, panels or shields. Keep away from live circuits, know your equipment and don't take chances.

WARNING

IN CASE OF EMERGENCY ENSURE THAT POWER HAS BEEN DISCONNECTED.

WARNING

IF OIL FILLED OR ELECTROLYTIC CAPACITORS ARE UTILIZED IN YOUR EQUIPMENT, AND IF A LEAK OR BULGE IS APPARENT ON THE CAPACITOR CASE WHEN THE UNIT IS OPENED FOR SERVICE OR MAINTENANCE, ALLOW THE UNIT TO COOL DOWN BEFORE ATTEMPTING TO REMOVE THE DEFECTIVE CAPACITOR. DO NOT ATTEMPT TO SERVICE A DEFECTIVE CAPACITOR WHILE IT IS HOT DUE TO THE POSSIBILITY OF A CASE RUPTURE AND SUBSEQUENT INJURY.

TREATMENT OF ELECTRICAL SHOCK

1. IF VICTIM IS NOT RESPONSIVE FOLLOW THE A-B-C'S OF BASIC LIFE SUPPORT.

PLACE VICTIM FLAT ON HIS BACK ON A HARD SURFACE

(A) AIRWAY

IF UNCONSCIOUS,
OPEN AIRWAY

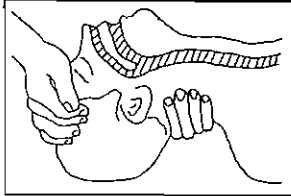

LIFT UP NECK
PUSH FOREHEAD BACK
CLEAR OUT MOUTH IF NECESSARY
OBSERVE FOR BREATHING

CHECK
CAROTID PULSE

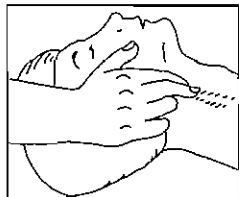

IF PULSE ABSENT,
BEGIN ARTIFICIAL
CIRCULATION

(B) BREATHING

IF NOT BREATHING,
BEGIN ARTIFICIAL BREATHING

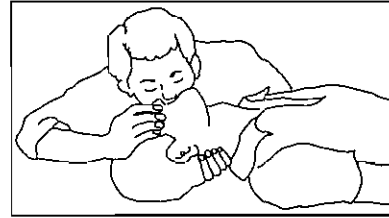

TILT HEAD
PINCH NOSTRILS
MAKE AIRTIGHT SEAL
4 QUICK FULL BREATHS
REMEMBER MOUTH TO MOUTH
RESUSCITATION MUST BE
COMMENCED AS SOON AS POSSIBLE

(C) CIRCULATION

DEPRESS STERNUM 1 1/2 TO 2 INCHES

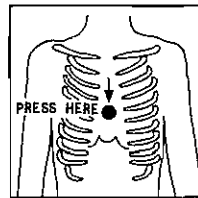

APPROX. RATE
OF COMPRESSIONS { ONE RESCUER
--80 PER MINUTE { 15 COMPRESSIONS
2 QUICK BREATHS

APPROX. RATE
OF COMPRESSIONS { TWO RESCUERS
--60 PER MINUTE { 5 COMPRESSIONS
1 BREATH

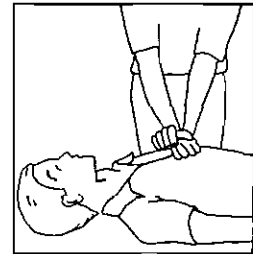

NOTE: DO NOT INTERRUPT RHYTHM OF COMPRESSIONS
WHEN SECOND PERSON IS GIVING BREATH

CALL FOR MEDICAL ASSISTANCE AS SOON AS POSSIBLE.

2. IF VICTIM IS RESPONSIVE.

- A. KEEP THEM WARM
- B. KEEP THEM AS QUIET AS POSSIBLE
- C. LOOSEN THEIR CLOTHING
- D. A RECLINING POSITION IS RECOMMENDED

FIRST-AID

Personnel engaged in the installation, operation, maintenance or servicing of this equipment are urged to become familiar with first-aid theory and practices. The following information is not intended to be complete first-aid procedures, it is brief and is only to be used as a reference. It is the duty of all personnel using the equipment to be prepared to give adequate Emergency First Aid and thereby prevent avoidable loss of life.

Treatment of Electrical Burns

1. Extensive burned and broken skin
 - a. Cover area with clean sheet or cloth. (Cleanest available cloth article.)
 - b. Do not break blisters, remove tissue, remove adhered particles of clothing, or apply any salve or ointment.
 - c. Treat victim for shock as required.
 - d. Arrange transportation to a hospital as quickly as possible.
 - e. If arms or legs are affected keep them elevated.

NOTE

If medical help will not be available within an hour and the victim is conscious and not vomiting, give him a weak solution of salt and soda: 1 level teaspoonful of salt and 1/2 level teaspoonful of baking soda to each quart of water (neither hot or cold). Allow victim to sip slowly about 4 ounces (a half of glass) over a period of 15 minutes. Discontinue fluid if vomiting occurs. (Do not give alcohol.)

2. Less severe burns - (1st & 2nd degree)
 - a. Apply cool (not ice cold) compresses using the cleanest available cloth article.
 - b. Do not break blisters, remove tissue, remove adhered particles of clothing, or apply salve or ointment.
 - c. Apply clean dry dressing if necessary.
 - d. Treat victim for shock as required.
 - e. Arrange transportation to a hospital as quickly as possible.
 - f. If arms or legs are affected keep them elevated.

REFERENCE: ILLINOIS HEART ASSOCIATION

AMERICAN RED CROSS STANDARD FIRST AID AND PERSONAL SAFETY MANUAL
(SECOND EDITION)

TABLE OF CONTENTS

<u>Paragraph</u>		<u>Page</u>
SECTION I. GENERAL DESCRIPTION		
1-1.	Introduction	1-1
1-3.	Equipment Purpose	1-1
1-5.	Physical Description	1-1
1-11.	Functional Description	1-3
1-12.	RF Circuit	1-3
1-14.	Audio Circuit	1-3
1-15.	Power Supplies	1-6
1-16.	Transmitter Protection	1-6
1-17.	Equipment Characteristics	1-6
1-18.	Electrical Characteristics	1-6
1-20.	Mechanical/Environmental Characteristics	1-6
SECTION II. INSTALLATION		
2-1.	Introduction	2-1
2-3.	Unpacking	2-1
2-5.	Returns and Exchanges	2-1
2-7.	Installation	2-1
2-9.	Cooling Air Requirements	2-1
2-11.	Transmitter Placement	2-2
2-14.	Component Installation	2-2
2-19.	Light Sensor Assembly Installation	2-14
2-25.	Connections Between Cabinets	2-30
2-28.	External Connections	2-34
2-30.	Connections to Remote Controls/Monitors	2-38
2-32.	Initial Turn On	2-41
2-35.	Modulator Check	2-42
2-36.	RF Section Check	2-48
2-37.	High Voltage Check	2-48
2-39.	Power and Modulation Check	2-51
2-40.	High Power Adjustment	2-51
2-41.	Low-Power Adjustment	2-53
2-42.	Typical Meter Readings	2-55
SECTION III. OPERATION		
3-1.	Introduction	3-1
3-3.	Controls and Indicators	3-1
3-5.	Operation	3-1
3-6.	Transmitter Turn On	3-1
3-8.	Transmitter Shutdown	3-2
3-10.	Modulation Enhancement	3-2
SECTION IV. PRINCIPLES OF OPERATION		
4-1.	Introduction	4-1
4-3.	Overall Functional Description	4-1
4-4.	RF Section	4-1
4-6.	Oscillator Chassis 1A10	4-1
4-7.	RF Driver 1A9V1	4-1

TABLE OF CONTENTS (Continued)

<u>Paragraph</u>		<u>Page</u>
4-8.	Power Amplifier 1A9V2	4-1
4-9.	PA Screen Automatic Gain Control	4-1
4-10.	Isolated Enclosure Power Supplies	4-2
4-11.	Output Network	4-2
4-12.	Directional Coupler	4-2
4-13.	Modulator Section	4-2
4-16.	Pulse Duration Modulation	4-2
4-25.	MW-50C3 PDM Circuitry	4-6
4-27.	PDM Circuit	4-6
4-28.	Damper Diode	4-7
4-29.	Modulator Power	4-7
4-30.	Control Circuits	4-8
4-32.	Control Assembly 1A1	4-8
4-33.	High Voltage Step/Start Assembly 3	4-8
4-34.	Fault Circuits	4-8
4-35.	Fault and Overload Assembly 1A3	4-8
4-36.	Multiple Faults	4-8
4-37.	High-Voltage Power Supply	4-8
4-39.	Filter Circuit	4-8
4-40.	Primary Requirements	4-9
4-41.	Metering Circuits	4-9
4-43.	Detailed Functional Description	4-10
4-44.	RF Section	4-10
4-45.	Oscillator 1A10	4-10
4-46.	Oscillator AGC Circuit	4-10
4-47.	Oscillator RF Output Circuit	4-10
4-48.	Oscillator Power Supply	4-10
4-49.	RF Driver 1A9V1	4-10
4-50.	RF Driver Neutralization	4-10
4-51.	RF Driver Plate Circuit	4-13
4-52.	Double Resonant Circuit	4-13
4-53.	Power Amplifier 1A9V2	4-13
4-55.	PA Screen Protection	4-13
4-56.	PA Neutralization	4-13
4-57.	Output Network	4-15
4-58.	Output Network Adjustment	4-15
4-60.	PA Efficiency Resonator Adjustment	4-15
4-62.	Directional Coupler 2A1	4-16
4-64.	Forward Power Sample	4-16
4-65.	Reflected Power Sample	4-16
4-66.	VSWR Trigger Unit	4-16
4-67.	Modulator Section	4-17
4-70.	Modulation Enhancer	4-17
4-73.	PDM Chassis	4-18
4-74.	PDM Board A1	4-18
4-80.	PDM Board A1	4-20
4-82.	PDM Feedback	4-20
4-85.	Viewing PDM Waveforms	4-21

TABLE OF CONTENTS (Continued)

<u>Paragraph</u>		<u>Page</u>
4-86.	PDM Waveforms	4-22
4-88.	Modulator Driver 1A8V1	4-22
4-89.	DC Coupler 1A7	4-22
4-90.	Auxiliary Modulation	4-22
4-91.	Auxiliary Driver Transistor 1Q1	4-22
4-93.	Modulator Tube 1V1	4-22
4-95.	Damper	4-23
4-96.	Modulator Power Supplies	4-23
4-97.	Control Circuits	4-23
4-99.	Transmitter Turn On	4-23
4-105.	Transmitter Turn Off	4-27
4-106.	High-Voltage Time-Delay Trip Circuit	4-27
4-107.	Automatic Return After Power Failure	4-27
4-109.	Power Change High/Low	4-28
4-110.	Power High	4-28
4-111.	Power Low	4-28
4-112.	Interlocks and Safety Switches	4-28
4-113.	Step/Start Assembly	4-28
4-114.	Fault and Overload Circuits	4-29
4-115.	Fault and Overload Assembly 1A3	4-29
4-116.	Power Amplifier Arc	4-29
4-118.	DC Overload	4-29
4-119.	Modulator Screen Overload	4-30
4-120.	Output Arc	4-30
4-121.	VSWR Overload	4-30
4-123.	Resonator Arc	4-30
4-124.	Arc Gap	4-30
4-125.	Remote Plate Voltage Sample	4-31
4-126.	Recycle Circuit	4-31
4-128.	Metering Circuits	4-31
4-130.	Supply Current Meter 1A11M1	4-32
4-131.	Power Meter 2A2M1	4-32
4-132.	Power Amplifier Screen Current Meter 1A9M4	4-32
4-133.	Power Amplifier Plate Current Meter 1A9M2	4-32
4-134.	Plate Volts Meter 1A11M2	4-32
4-135.	Supply Volts Meter 2A2M2	4-32
4-137.	Power Supplies	4-33
4-138.	High-Voltage Power Supply	4-33
4-139.	PA Screen Power Supply	4-33
4-140.	PA Bias Power Supply	4-33
4-142.	Modulator Screen and Driver Power Supply	4-33
4-143.	Modulator Bias Power Supply	4-33
4-144.	Oscillator/Buffer Power Supply	4-35
4-145.	Fault and Overload Assembly Power Supply	4-35

TABLE OF CONTENTS (Continued)

<u>Paragraph</u>		<u>Page</u>
SECTION V. MAINTENANCE		
5-1.	Introduction	5-1
5-3.	Purpose	5-1
5-5.	Station Records	5-1
5-7.	Transmitter Logbook	5-1
5-9.	Maintenance Logbook	5-1
5-11.	Safety Precautions	5-2
5-14.	Preventive Maintenance	5-2
5-16.	Filter Cleaning	5-3
5-18.	Blower and Fan Maintenance	5-3
5-20.	Air Pressure Meter Calibration	5-3
5-23.	High-Voltage Power Supply	5-6
5-24.	Maintenance of Components	5-6
5-26.	Transistors	5-7
5-27.	Capacitors	5-7
5-28.	Vacuum Capacitors	5-7
5-31.	Fixed Resistors	5-8
5-32.	Variable Resistors	5-8
5-33.	Transformers	5-8
5-34.	Fuses	5-9
5-35.	Meters	5-9
5-36.	Relays	5-9
5-37.	Switches	5-10
5-38.	Indicators and Indicator Switches	5-10
5-39.	Printed-Circuit Boards	5-11
5-40.	Corrective Maintenance	5-11
5-42.	Oscillator Test and Alignment	5-11
5-44.	PDM Frequency Adjustment	5-12
5-46.	Ball Gap Adjustment	5-12
5-48.	Alignment/Adjustment Procedures	5-12
5-50.	Test Equipment	5-12
5-51.	Efficiency Resonator Adjustment for PA Plate	5-13
5-52.	RF Driver Plate and PA Grid Efficiency Resonator Adjustment	5-14
5-53.	Directional Coupler Adjustment	5-16
5-54.	Audio Input/PDM Control - Feedback Board	5-18
5-55.	Audio Board Alignment	5-18
5-56.	Audio Board Adjustment	5-19
5-57.	Bessel Filter Adjustment	5-20
5-58.	Low-Frequency -3 dB Point Adjustment	5-20
SECTION VI. TROUBLESHOOTING		
6-1.	Introduction	6-1
6-3.	Troubleshooting	6-1
6-8.	Technical Assistance	6-2

TABLE OF CONTENTS (Continued)

<u>Paragraph</u>		<u>Page</u>
	SECTION VII. PARTS LIST	
7-1.	Introduction	7-1
7-3.	Replaceable Parts Service	7-1
	SECTION VIII. WIRE LIST	
8-1.	Introduction	8-1
	SECTION IX. DIAGRAMS	
9-1.	Introduction	9-1
	APPENDIX A. HIGH-VOLTAGE POWER SUPPLIES	
A-1.	Introduction	A-2
	APPENDIX B. MANUFACTURERS DATA	
B-1.	Introduction	B-2

LIST OF TABLES

<u>Table</u>	<u>Page</u>
1-1. Electrical Characteristics	1-7
1-2. Mechanical/Environmental Characteristics	1-9
2-1. Typical Meter Readings (100 Percent Modulation)	2-55
3-1. Meter Panel Controls and Indicators	3-5
3-2. Cabinet 1 Left Side Controls and Indicators	3-8
3-3. Cabinet 1 Fault and Overload Assembly Printed-Circuit Board Controls and Indicators	3-13
3-4. Cabinet 1 PDM Controls and Indicators	3-15
3-5. Cabinet 1 Internal Controls and Indicators	3-18
3-6. Cabinet 1 Right Side Controls and Indicators	3-20
3-7. Cabinet 2 Left Side Controls and Indicators	3-23
3-8. Cabinet 2 Right Side Controls and Indicators	3-25
4-1. Characteristic Multiphase Supply Ripple	4-9
6-1. Fault Isolation Procedures	6-3
6-2. Modulation Enhancer 1A2A3 Troubleshooting	6-11
7-1. Replaceable Parts List Index	7-2
7-2. XMTR, 50KW AM MW50C3 60HZ	7-3
7-3. Basic MW50C3 Transmitter	7-6
7-4. Unit 1, Mod & PA Cubicle	7-7
7-5. Control Unit 1A1	7-11
7-6. Printed Relay Board	7-12
7-7. PDM Unit 1A2	7-13
7-8. PDM Printed Board	7-14
7-9. PTD Bd Audio Input Assy	7-16
7-10. PDM POT Kit-MW5/10/50	7-18
7-11. PWB, Mod Enhancer.....	7-19
7-12. PWB, Interface 1A2A4	7-20
7-13. Flag & Overload 1A3	7-21
7-14. Flag & Overload 1A3A1	7-22
7-15. Bias Pwr Supply 1A5	7-24
7-16. D.C.Coupler 1A7	7-25
7-17. Audio Driver 1A8	7-26
7-18. Isolated Box 1A9	7-27
7-19. Metering Board 1A9A1.....	7-29
7-20. Metering & Bias 1A9A2	7-30
7-21. Meter Multiplier 1A9A4	7-31
7-22. PWB, Oscillator 1A10A1&2	7-32
7-23. Meter Panel 1A11	7-33
7-24. Switch Board 1A11A1	7-34
7-25. Assy. GRD Switch	7-35
7-26. AUX Driver/Meter Mult 1A14	7-36
7-27. PA Arc Detector	7-37
7-28. Mtr Ltg Iso Box 1A16	7-38

LIST OF TABLES (Continued)

<u>Table</u>		<u>Page</u>
7-29	Resonator Assembly.....	7-39
7-30.	Unit 2, Output Cubicle	7-40
7-31.	Directional Cplr 2A1	7-42
7-32.	PWB, Dir Cplr 2A1A1	7-43
7-33.	Feedback Board 2A3.....	7-44
7-34.	Meter Multiplier 2A4	7-45
7-35.	Switch, Shorting	7-46
7-36.	Unit #3, Step Start	7-47

LIST OF ILLUSTRATIONS

<u>Figure</u>		<u>Page</u>
1-1.	MW-50C3 MEDIUM WAVE AM BROADCAST TRANSMITTER	1-2
1-2.	High-Voltage Step/Start Assembly	1-4
1-3.	MW-50C3 Simplified Block Diagram	1-5
2-1.	MW-50C3 Outline Drawing (Sheet 1 of 4)	2-3
2-1.	MW-50C3 Outline Drawing (Sheet 2 of 4)	2-5
2-1.	MW-50C3 Outline Drawing (Sheet 3 of 4)	2-7
2-1.	MW-50C3 Outline Drawing (Sheet 4 of 4)	2-9
2-2.	Cabinet 2 Upper Right Rear	2-11
2-3.	Cabinet 2 Lower Right Rear	2-12
2-4.	Cabinet 1 Lower Left Front and Door	2-15
2-5.	Cabinet 1 Left Front	2-16
2-6.	Cabinet 1 Upper Left Rear	2-17
2-7.	Cabinet 1 Lower Right Front	2-18
2-8.	Cabinet 1 Left Rear	2-19
2-9.	Cabinet 1 Left Rear	2-20
2-10.	Cabinet 2 Upper Left Rear (Sheet 1 of 2)	2-21
2-10.	Cabinet 2 Lower Left Rear (Sheet 2 of 2)	2-22
2-11.	Cabinet 2 Lower Right Front	2-23
2-12.	Cabinet 2 Lower Left Front	2-24
2-13.	Oscillator Top	2-25
2-14.	Oscillator Bottom	2-26
2-15.	Control Panel	2-27
2-16.	High-Voltage Step-Start Assembly	2-28
2-17.	Modulator	2-31
2-18.	Cabinet 2 Lower Right Rear	2-32
2-19.	Wiring Between Cabinet 1 and 2	2-33
2-20.	Wiring Diagram (Sheet 1 of 3)	2-35
2-20.	Wiring Diagram (Sheet 2 of 3)	2-36
2-20.	Wiring Diagram (Sheet 3 of 3)	2-37
2-21.	Remote Plate Current Sensor Adjustment	2-40
2-22.	Cabinet 1 Lower Right Rear	2-45
2-23.	Cabinet 2 Lower Left Rear	2-46
2-24.	PDM Controls	2-49
2-25.	Low Power Distortion Adjustment	2-54
3-1.	Meter Panel Controls and Indicators	3-4
3-2.	Cabinet 1 Left Side Controls and Indicators (Sheet 1 of 2)	3-6
3-2.	Cabinet 1 Left Side Controls and Indicators (Sheet 2 of 2)	3-7
3-3.	Cabinet 1 Fault and Overload Assembly Printed-Circuit Board Controls and Indicators	3-12
3-4.	Cabinet 1 PDM Controls and Indicators	3-14
3-5.	Cabinet 1 Internal Controls and Indicators	3-17
3-6.	Cabinet 1 Right Side Controls and Indicators	3-19
3-7.	Cabinet 2 Left Side Controls and Indicators	3-22
3-8.	Cabinet 2 Right Side Controls and Indicators	3-24

LIST OF ILLUSTRATIONS (Continued)

<u>Figure</u>	<u>Page</u>
4-1. MW-50C3 Transmitter Block Diagram	4-3
4-2. PDM Equivalent Circuit	4-5
4-3. PDM Simplified Circuit	4-6
4-4. MW-50C3 Transmitter PDM	4-7
4-5. 12 Phase Circuit	4-9
4-6. Simplified Signal Path Schematic	4-11
4-7. RF Driver Plate Circuit	4-14
4-8. PA Output Waveform	4-16
4-9. PDM Waveforms	4-19
4-10. Control Circuit Simplified Schematic	4-25
4-11. High Voltage Metering	4-34
5-1. Oscillator Unit Bench Test Cable	5-11
5-2. Test Setup for Efficiency Resonator Adjustment for PA Plate	5-13
5-3. Test Setup for RF Driver Plate and PA Grid Efficiency Resonator Adjustment	5-15
5-4. Directional Coupler 2A1, Adjustment Locations	5-17
9-1. Overall Schematic - MW-50C3	9-3
9-2. PDM Modulator	9-5
9-3. Output Network	9-7
9-4. RF Amplifier Isolated Enclosure	9-9
9-5. RF Oscillator 1A10	9-11
9-6. PDM Chassis/Audio Board (Sheet 1 of 2)	9-13
9-6. PDM Chassis/Audio Board (Sheet 2 of 2)	9-15
9-7. Fault and Overload Circuit	9-17
9-8. Remote Plate Current Sensor	9-19
9-9. PA Arc Detector	9-21
9-10. Directional Coupler	9-23
9-11. Modulation Enhancer	9-25
9-12. Utility Outlets and Lights	9-27
9-13. Frequency Determining Components	9-29

SECTION I
DESCRIPTION

1-1. INTRODUCTION

1-2. This Technical Manual contains the information necessary to install, operate, maintain and service the HARRIS MW-50C3 MEDIUM WAVE AM BROADCAST TRANSMITTER. Sections in this manual provide the following information:

- a. SECTION I, GENERAL DESCRIPTION, provides a description of equipment features at block diagram level and lists the operating parameters and specifications.
- b. SECTION II, INSTALLATION, provides unpacking and installation information, power requirements and preliminary checkout and operation.
- c. SECTION III, OPERATION, identifies control and indicator function, together with their set up and operation.
- d. SECTION IV, PRINCIPLES OF OPERATION, provides functional and detailed theory with supporting drawings.
- e. SECTION V, MAINTENANCE, provides preventive and corrective maintenance information.
- f. SECTION VI, TROUBLESHOOTING, contains fault location guides and troubleshooting with instructions for equipment servicing.
- g. SECTION VII, PARTS LIST, provides information for ordering replacement components and assemblies.
- h. SECTION VIII, WIRE LIST, provides wiring information with origin and termination points of identified cables and wires.
- i. SECTION IX, DIAGRAMS, provides block, logic and schematic diagrams and other drawings necessary for transmitter maintenance.

1-3. EQUIPMENT PURPOSE

1-4. The HARRIS MW-50C3 MEDIUM WAVE AM BROADCAST TRANSMITTER (figure 1-1) is a high-level, plate-modulated, 50kW AM transmitter using Pulse Duration Modulation (PDM). PDM design allows continuous 100 percent sine-wave modulation which permits high-average modulation, boosting signal strength without increasing transmitter carrier power. Up to 130 percent positive-peak modulation capability is provided when operating full 50kW rf power output.

1-5. PHYSICAL DESCRIPTION

1-6. The unit is contained in two cubicles except for the High-Voltage Power Supply and a wall-mounted High-Voltage Step-Start Assembly shown in

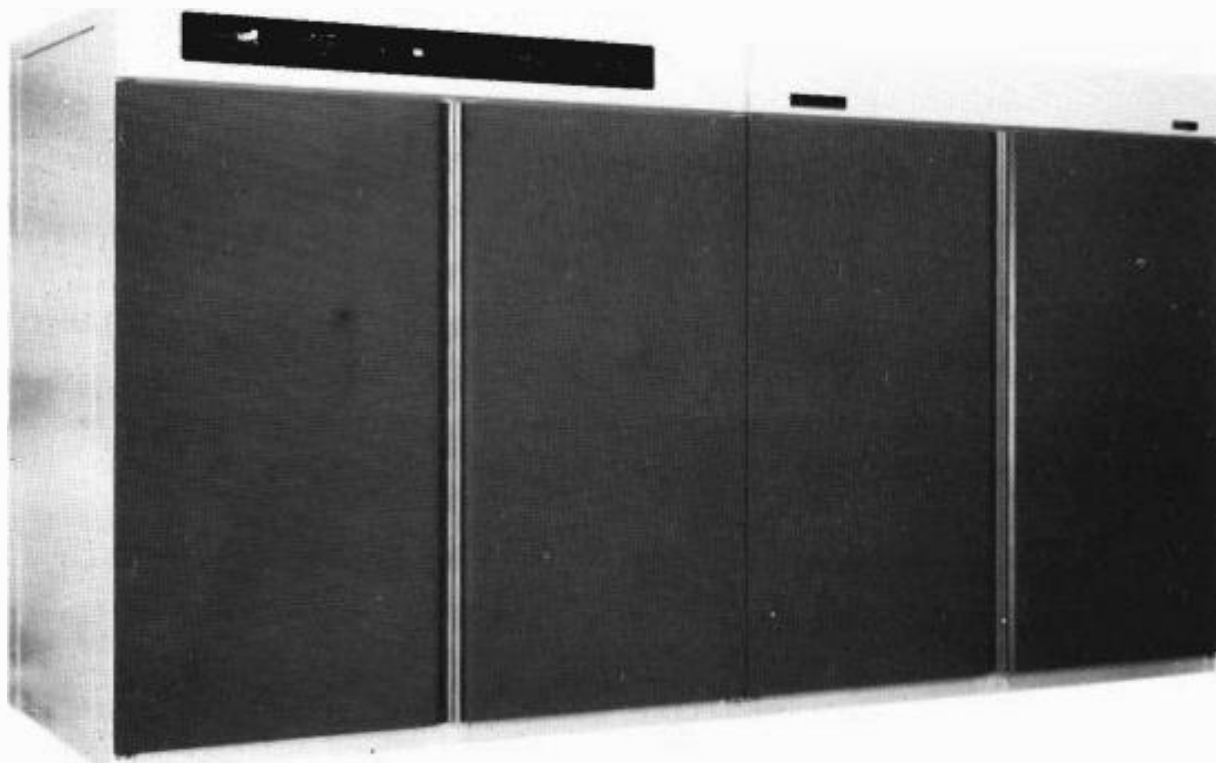

NOTE

SHOWN WITH OPTIONAL FRONT DOOR KIT
ACCESSORY (994 8996 001) MOUNTED.

Figure 1-1. MW-50C3 MEDIUM WAVE AM BROADCAST TRANSMITTER

figure 1-2. Components are accessible through four rear doors and five front access door. Meter panels are hinged for inspection and maintenance. External connections to the transmitter are made through either the top or bottom as desired for installation flexibility.

1-7. The entire transmitter uses just three tubes, all operating well below the manufacturers dissipation ratings. Only two tube types are used, which simplifies stocking the of spares. The rf section is conventional, using solid state circuitry to drive a Tetrode RF Driver Tube (4CX1500A) and a Tetrode PA Stage Tube (4CX35000C). Solid-state circuitry is used throughout the modulator with exception of the Modulator Tube (4CX35000C).

1-8. After preliminary adjustment of internal high-power and low-power level controls has been accomplished, output power levels may be selected with front panel switches. Variations of ± 20 percent in output power are accomplished with a front panel fine adjustment control acting on a low-level modulator stage. Additional tuning when switching power levels is not required. An AGC circuit limits PA screen current to eliminate problems of PA screen over-dissipation.

1-9. Major components of the transmitter are protected by circuit breakers. Tubes and transistors are protected by overload relays or current-limiting devices. Momentary rf overloads will cause the Transmitter to recycle automatically. Should repeated overloads occur within 30 seconds, the transmitter will remain off until manually reset. If the time between overloads is greater than 30 seconds, continuous recycling will occur.

1-10. A five-horsepower blower operating at 3200 CFM air at two-inch water gauge pressure and a flushing fan, both operating at low-noise level, provide transmitter cooling. Provisions are available at the top of the transmitter cabinet to duct exhaust air to the outside of the transmitter building.

1-11. FUNCTIONAL DESCRIPTION

1-12. RF CIRCUIT. The rf chain of the MW-50C3 Transmitter is transistorized up to the RF Driver (figure 1-3). Two crystal-controlled Oscillators, each with two individual amplifier stages, feed a class C operated transistor stage (transistors Q1 and Q2). The output of the class C transistor stage drives the 4CX1500A RF Driver Tube, operated class AB₁, to provide drive for the 4CX35000C Power Amplifier Tube, operated class D, as ON-OFF switch.

1-13. Because the PA and Modulator Tubes are connected in series, either the rf circuit or the modulator must float above ground potential. The rf circuitry is placed off ground in an Isolated Enclosure because capacitance formed with ground would distort the modulator waveform if the modulator were placed off ground.

1-14. AUDIO CIRCUIT. Audio at +10 dBm is fed to the PDM circuit. PDM output drives the modulator driver stage (Mosfet Buz 53A) to operate Modulator Tetrode Tube 4CX35000C. The modulator is connected to the PA stage through a Low-Pass Filter. The filter removes the 75 kHz frequency component and its harmonics from the PA plate current. The damper diode connected between the

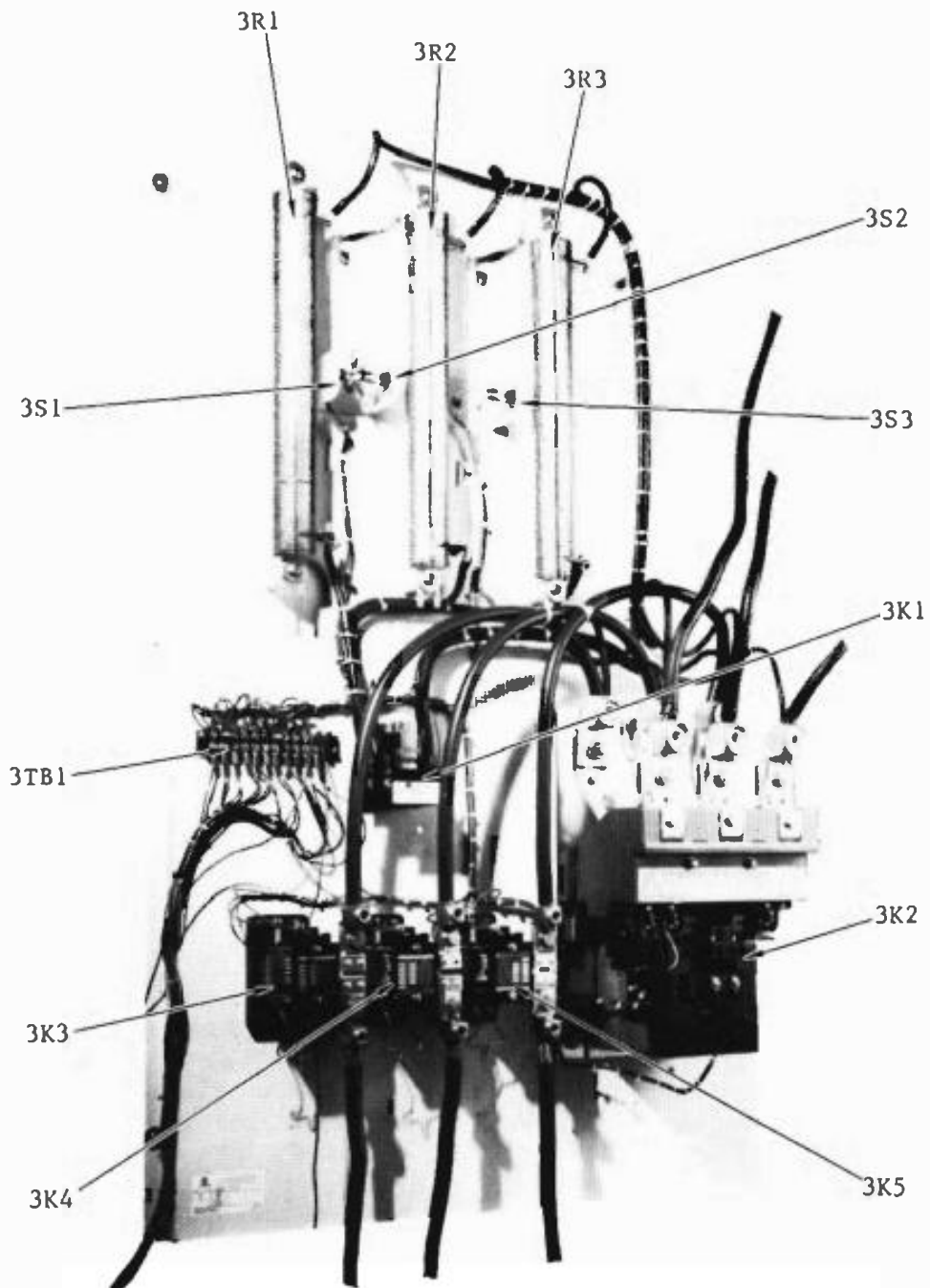

Figure 1-2. High-Voltage Step/Start Assembly

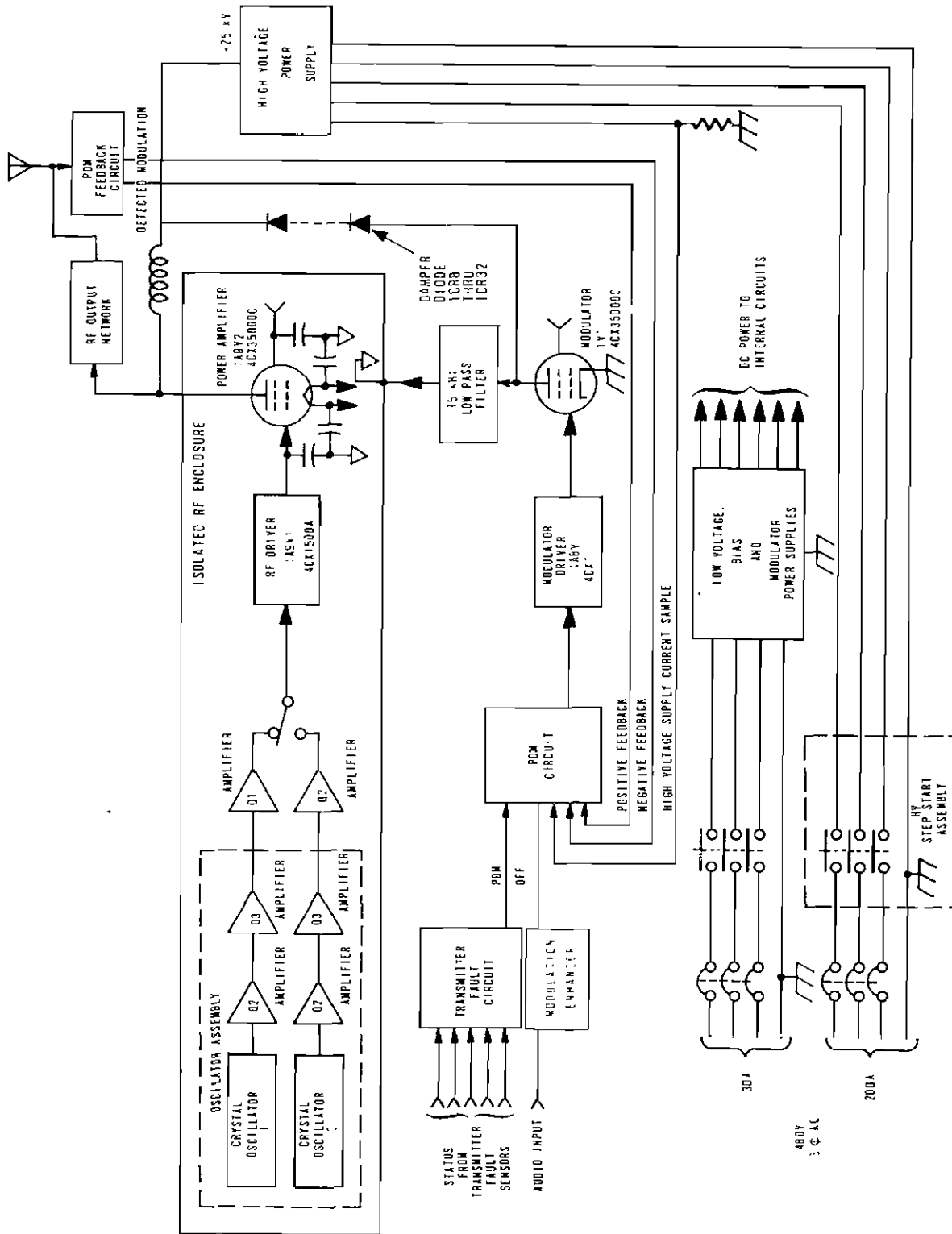

Figure 1-3. MW-50C3 Simplified Block Diagram

WARNING: Disconnect primary power prior to servicing.

modulator plate and the +25 kV supply conducts alternately with the modulator at the 75 kHz rate to provide a current path for the energy stored in the Low-Pass Filter when the modulator is cut off. The PDM circuit monitors High-Voltage Supply current and PA output to provide automatic PA plate dissipation limiting and automatic carrier shift control. A Modulation Enhancer has been built into the PDM compartment. A bypass switch is incorporated to enable operation with or without the Modulation Enhancer.

1-15. POWER SUPPLIES. Primary three-phase current at 30 amperes is required for the MW-50C3 Transmitter internal power supplies and a separate 200-ampere circuit is required for the High-Voltage Power Supply. Fast acting contactors protect the power supplies from short circuits. Each contactor automatically resets after an overload. The MW-50C3 Transmitter contains the following six internal power supplies.

- a. Power Amplifier Screen 900 Vdc at 2.5 amperes
- b. Power Amplifier Bias -600 Vdc at 2 amperes
- c. Modulator Screen 800 Vdc at 2.4 amperes
- d. Modulator Bias -500 Vdc
- e. Crystal Oscillator/Buffer 100 Vdc
- f. Fault and Overload Relay Assembly Supplies +30 Vdc

1-16. TRANSMITTER PROTECTION. Transmitter fault circuits accept inputs such as high VSWR, arcs in the modulator, PA, or output circuitry, high-voltage overload status and inputs from safety and fault sensors such as dc interlock status. If a fault or safety sensor is activated, the PDM circuit is provided with an OFF signal. This OFF signal removes PDM drive from the modulator and turns the modulator off to open the PA plate current path and shut the transmitter down. If the fault clears or is reset, the transmitter will automatically return to operation if the automatic return to air feature is energized.

1-17. EQUIPMENT CHARACTERISTICS

1-18. ELECTRICAL CHARACTERISTICS

1-19. Table 1-1 lists electrical operating characteristics and parameters of the HARRIS MW-50C3 MEDIUM WAVE AM BROADCAST TRANSMITTER.

1-20. MECHANICAL/ENVIRONMENTAL CHARACTERISTICS

1-21. Table 1-2 lists physical/environmental characteristics of the HARRIS MW-50C3 MEDIUM WAVE AM BROADCAST TRANSMITTER.

1-22. SPECIFICATIONS ARE SUBJECT TO CHANGE WITHOUT NOTICE.

Table 1-1. Electrical Characteristics

FUNCTION	CHARACTERISTIC
Power Output	50kW (rated), 60kW (capable). Convenient power reduction through 10kW.
RF Frequency Range	535 kHz to 1620 kHz
RF Output Impedance	50 ohms unbalanced
RF Output Terminal	3-1/8" EIA 50 ohm flange
RF Frequency Stability	±10 Hz
RF Harmonics and Spurious Emissions	Exceeds FCC and CCIR specifications.
Carrier Amplitude Regulation	Less than 2% at 100% modulation (measured at 1000 Hz).
Audio Intermodulation Distortion	2.4% or less, 60/7000 Hz 4:1, SMPTE standard @ 55kW operation @ 90% modulation.
Audio Frequency Response	±1.0 dB, from 20 to 12,500 Hz referenced to 1,000 Hz at 95% modulation at 55kW with Besel filter out.
Squarewave Overshoot	Less than 3.0% using 1,000 Hz 6 dB clipped sinewave @ 90% modulation.
Total Harmonic Distortion (Unenhanced)	Less than 2.4%, 20 to 10,000 Hz at 95% modulation at 55kW. 3% at 25 to 10kW. ¹
Squarewave Tilt	Less than 8% at 20 Hz @ 60% modulation.
Compression Ratio	4/1 dB at 3 dB of enhancement; -95%, +125% modulation.
Positive Peak Capability	+125% with program modulation at 55kW.

Table 1-1. Electrical Characteristics (Continued)

FUNCTION	CHARACTERISTIC
Noise (Unweighted)	-60 dB or better below 100% modulation. Typical -62 dB. ²
AM Stereo Operation	Incidental Quadrature Modulation (IQM) is down 25 dB or better at 95% modulation.
Audio Input	600 ohms at 0 to +10 dBm for 100% modulation, unenhanced; +16 dBm with enhancement activated.
Power Input	480V <u>+5%</u> , 3 phase, 60 Hz
Power Consumption	80kW at 0% modulation 87kW at 30% modulation 110kW at 100% modulation ³
Overall Efficiency	Better than 60% at average modulation
Power Factor	95%
Tubes Used	(2) 4CX35000C (1) 4CX1500A
Monitor Provision	An unmodulated sample is provided for freq monitor and a modulated sample for modulation monitoring.
Remote Control	Self-contained interface for extended or remote control.
<ol style="list-style-type: none"> 1. If transmitter is operated into a bandwidth limited antenna system, distortion at the higher modulation frequencies may degrade. 2. Noise measured over the band 20 Hz to 20 kHz, with line-to-line voltages of the supply line balanced. Noise may degrade with line voltage unbalance. 3. Typical power consumption figures are for 50 kilowatts output and for optimum transmitter adjustment. For high output power and/or transmitter misadjustments, power consumption may be higher. 	

Table 1-2. Mechanical/Environmental Characteristics

FUNCTION	CHARACTERISTIC
Dimensions, Transmitter	Width 144 in. (3.7 meters) Depth 48 in. (1.3 meters) Height 78 in. (2.0 meters)
High Voltage Power Supply	Width 58 in. (1.47 meters) Depth 37.5 in. (0.95 meters) Height 60 in. (1.52 meters)
Wall Mounted Circuit Breaker:	Width 30 in. (0.77 meters) Depth 10 in. (0.26 meters) Height 46.3 in. (1.18 meters)
Floor Space Main Transmitter Assembly	48 Sq. Ft. (4.5 square meters)
High-Voltage Power Supply	15 Sq. Ft. (1.4 square meters)
Weights (approximate)	
Main Transmitter Assembly	Net unpacked 5000 pounds (2268 kg) Domestic packed 6000 pounds (2722 kg) Export packed 7200 pounds (3266 kg)
50kW High-Voltage Power Supply (Wet)	Net unpacked 650 pounds (294.84 kg) Domestic packed 1780 pounds (807.39 kg) Export packed 2080 pounds (943.47 kg)
Wall Mounted Circuit Breaker	Net unpacked 75 pounds (34 kg) Domestic packed 125 pounds (57 kg) Export packed 150 pounds (68 kg)
Cubage Complete Transmitter	700 cu. ft. (19.82 cu. meters)
Operating Temperature Range	-20°C to +50°C at sea level (derate 2° per 306 meters altitude)
Humidity	95% maximum
Altitude	10,000 Ft (3048 meters) above sea-level maximum

SECTION II
INSTALLATION

2-1. INTRODUCTION

2-2. This section contains information for installing the HARRIS MW-50C3 MEDIUM WAVE AM BROADCAST TRANSMITTER and performing preoperational checks. Many components are removed from the transmitter after final test for shipment. These components will be identified with appropriate instructions for reinstallation and wiring.

2-3. UNPACKING

2-4. Carefully unpack the MW-50C3 Transmitter and perform a visual inspection to determine that no apparent damage was incurred during shipment. Retain the shipping materials until it has been determined that the unit is not damaged. The contents of the shipment should be as indicated on the packing list. If the contents are incomplete or if the unit is damaged electrically or mechanically, notify the carrier and HARRIS CORPORATION, Broadcast Transmission Division.

2-5. RETURNS AND EXCHANGES

2-6. Damaged or undamaged equipment should not be returned unless written approval and a Return Authorization is received from HARRIS CORPORATION, Broadcast Division. Special shipping instructions and coding will be provided to assure proper handling. Complete details regarding circumstances and reasons for return are to be included in the request for return. Custom equipment or special order equipment is not returnable. In those instances where return or exchange of equipment is at the request of the customer, or convenience of the customer, a restocking fee will be charged. All returns will be sent freight prepaid and properly insured by the customer. When communicating with HARRIS CORPORATION, Broadcast Division, specify the HARRIS Order Number or Invoice Number.

2-7. INSTALLATION

2-8. Prior to installation, this Technical Manual should be carefully studied to get a thorough understanding of the principles of operation, circuitry, and nomenclature. This will facilitate proper installation and initial checkout. The MW-50C3 Transmitter installation is accomplished in four steps, transmitter placement, component installation, transmitter wiring, and initial turn on and checkout.

2-9. COOLING AIR REQUIREMENTS

2-10. Air ducting should offer no restrictions to a minimum air flow of 5000 CFM. If possible, the transmitter room should be under positive pressure with the air supply as clean as possible. Air filters are located in the outside rear doors and consists of a 1 x 26 x 33 inch (2.54 x 66.04 x 83.82 cm) washable, expanded foam element. Replacement filters are available

from HARRIS CORPORATION, Broadcast Transmission Division as required. Exhaust air may be ducted out of the transmitter room but the duct system must not introduce any back pressure on the transmitter exhaust. The exhaust fan in the duct system must overcome duct losses and overcome any wind pressures if vented to the outside. Two cooling air configurations are available. Refer to figure 2-1.

- a. Rear air intake using internal blower and fan exhausting at transmitter top into free air.
- b. Base entry of filtered air using internal blower and fan.
 1. The Modulator and PA Cabinet requires 2200 CFM through any combination of "A" openings. The air system must overcome all duct and entrance losses with positive pressure in the blower compartment.
 2. The Output Cabinet requires 3000 CFM through any combination of "B" openings. The air system must overcome all duct and entrance losses with positive pressure in the fan compartment.

2-11. TRANSMITTER PLACEMENT

2-12. The two cubicles of this transmitter, as shown in figure 2-1, should be placed in position, aligned level, and bolted together with 3/8-16 X 1-inch bolts, flat washers, lock washers, and nuts. Install the four aluminum channels around the edges of the large opening between cubicles with 10-32 X 1/2-inch screws and lockwashers. The bottom channel mounts three cast mica capacitors (1C2, 1C2A and 1C2B). Figure 2-2 and 2-3 show component installation between cabinets.

2-13. The High-Voltage Power Supply, Transmitter, and the Step-Start Assembly should be located close to each other near the main ac power entrance to eliminate running heavy power cables any great distance.

2-14. COMPONENT INSTALLATION

2-15. Tubes, capacitors, connectors, cables, etc. are shipped in separate cartons. The removal of components varies due to method and requirements of shipment. All removed items are tagged to permit reinstallation in the transmitter. Arrange these components in separate groups according to the section from which they were removed. Parts in the interior should be installed first. Both front and rear transmitter doors are removed for shipment and should be left off until the installation of removed components and cabinet wiring hook up is complete.

2-16. Items such as interconnecting wires and cables, shock mounted devices, and miscellaneous small parts may be taped or tied in for shipment. Remove all tape, string, and packing material that has been used for this purpose. BE SURE TO REMOVE ALL THE TAPE THAT MAY HAVE BEEN INSTALLED AS ANTI-CHAFFING STRIPS BETWEEN ALUMINUM PANELS.

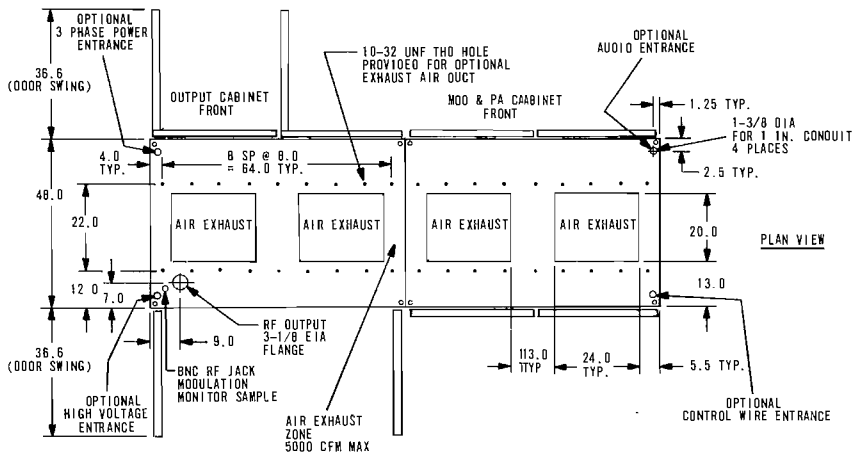

MECHANICAL DATA FOR MW-50C

AUDIBLE NOISE MEASUREMENT:

1 METER FROM FLOOR AND 1 METER FROM EACH ENCLOSURE.

MODULATOR FRONT	--	70 dBA
MODULATOR REAR	-	88 dBA
PA FRONT	-	69 dBA
PA REAR	-	81 dBA
OUTPUT 1 FRONT	-	67 dBA
OUTPUT 1 REAR	-	77 dBA
OUTPUT 2 FRONT	-	67 dBA
OUTPUT 2 REAR	-	75 dBA

AIR FLOW THROUGH THE TRANSMITTER:

FLUSHING AIR (COOLS OUTPUT NETWORK, AND AREA ABOVE P.A. AND MOD. TUBES) 3000 CFM.

HIGH PRESSURE AIR (COOLS PA, MODULATOR AND DRIVER TUBES). 2200 CFM TOTAL.

AIR THROUGH P.A. TUBE = 860 CFM.

AIR THROUGH MOD TUBE = 860 CFM.

AIR THROUGH DRIVER TUBES = 480 CFM TOTAL.

AIR TEMP RISE THROUGH PA TUBE = 36°C.

AIR TEMP RISE THROUGH MOD TUBE = 38°C.

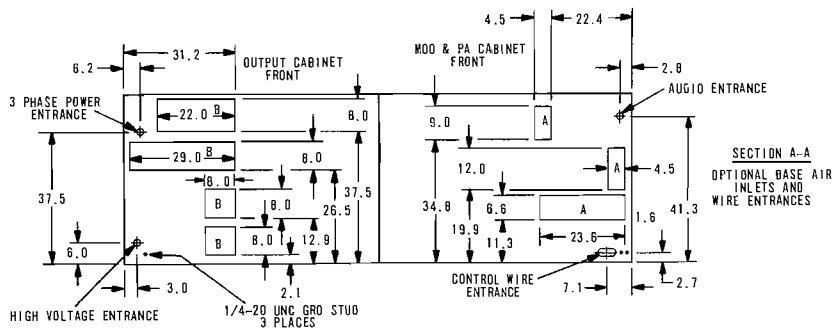
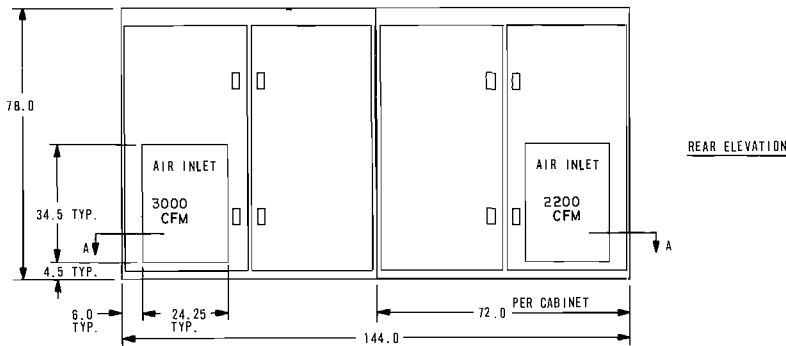
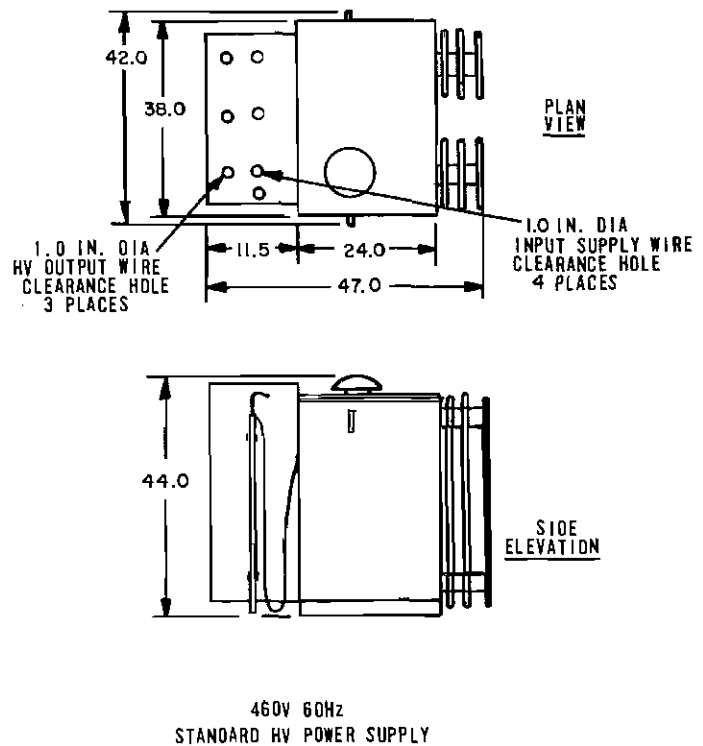
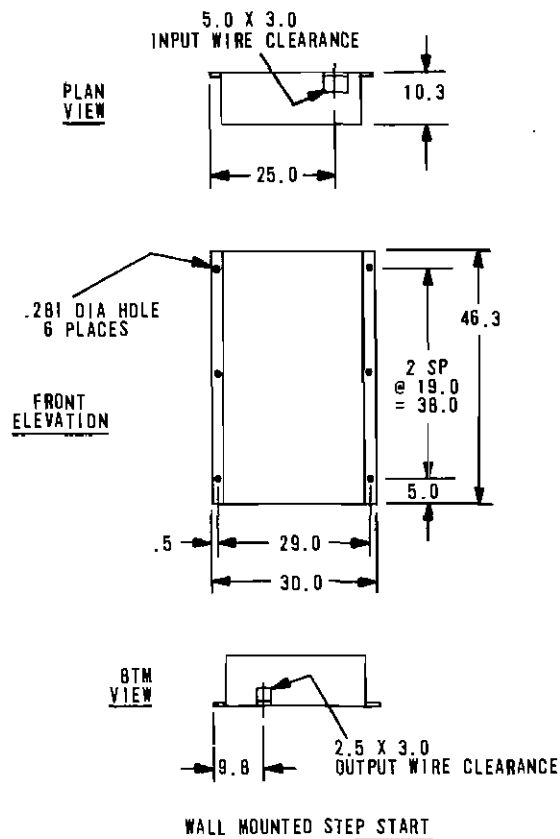

FIGURE 2-1. MW-50C3 OUTLINE DRAWING
(SHEET 1 OF 4)
839 6587 128-A

888-2213-0011
2-3/2-4



COOLING AIR REQUIREMENTS

- OPTION 1 - REAR AIR INTAKE USING INTERNAL PRESSURE BLOWER AND FLUSHING FAN EXHAUSTING AT TRANSMITTER TOP INTO FREE AIR.
- OPTION 2 - BASE ENTRY OF FILTERED AIR USING INTERNAL PRESSURE BLOWER AND FLUSHING FAN.
- AIR REQUIREMENTS ARE AS FOLLOWS
1. MOD AND PA REQUIRE 2200 CFM THRU ANY COMBINATION OF "A" OPENINGS. CUSTOMER AIR SYSTEM MUST OVERCOME ALL DUCT AND ENTRANCE LOSSES (NO NEGATIVE PRESSURE IN BLOWER COMPARTMENT).
 2. OUTPUT REQUIRES 3000 CFM THRU ANY COMBINATION OF "B" OPENINGS. CUSTOMER AIR SYSTEM MUST OVERCOME ALL DUCT AND ENTRANCE LOSSES (NO NEGATIVE PRESSURE IN FAN COMPARTMENT).

NOTE: EXHAUST AIR 5200 CFM MAY BE DUCTED OUT OF TRANSMITTER ROOM IN ANY OF THE ABOVE OPTIONS. THE DUCT SYSTEM MUST NOT INTRODUCE ANY BACK-PRESSURE ON THE TRANSMITTER EXHAUST. (THE EXHAUST FAN IN THE DUCT SYSTEM MUST OVERCOME DUCT LOSSES AND OVERCOME ANY WIND PRESSURES IF VENTED TO OUTSIDE).

FIGURE 2-1. MW-50C3 OUTLINE DRAWING
(SHEET 2 OF 4)
839 6587 128-A

888-2213-0011
2-5/2-6

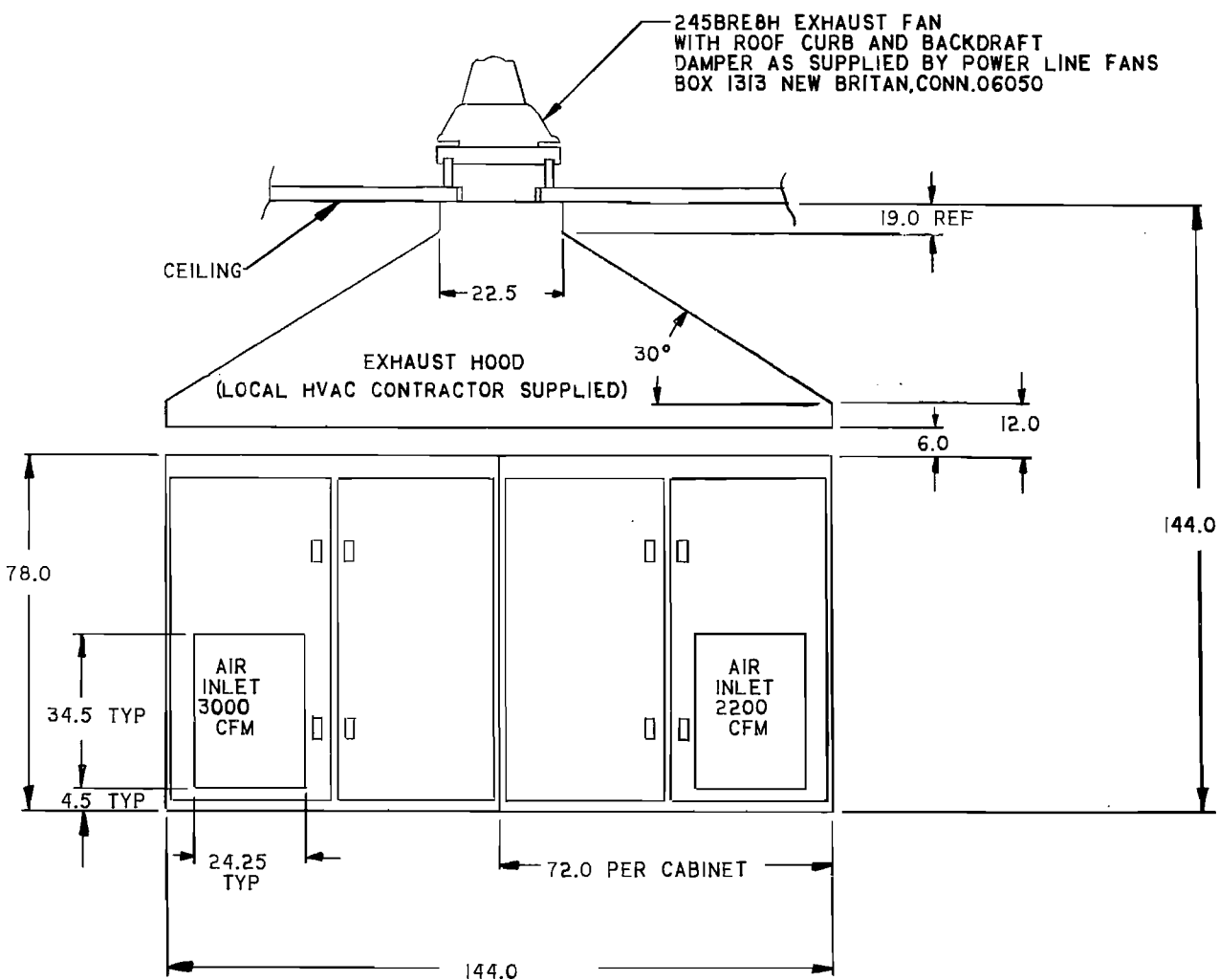
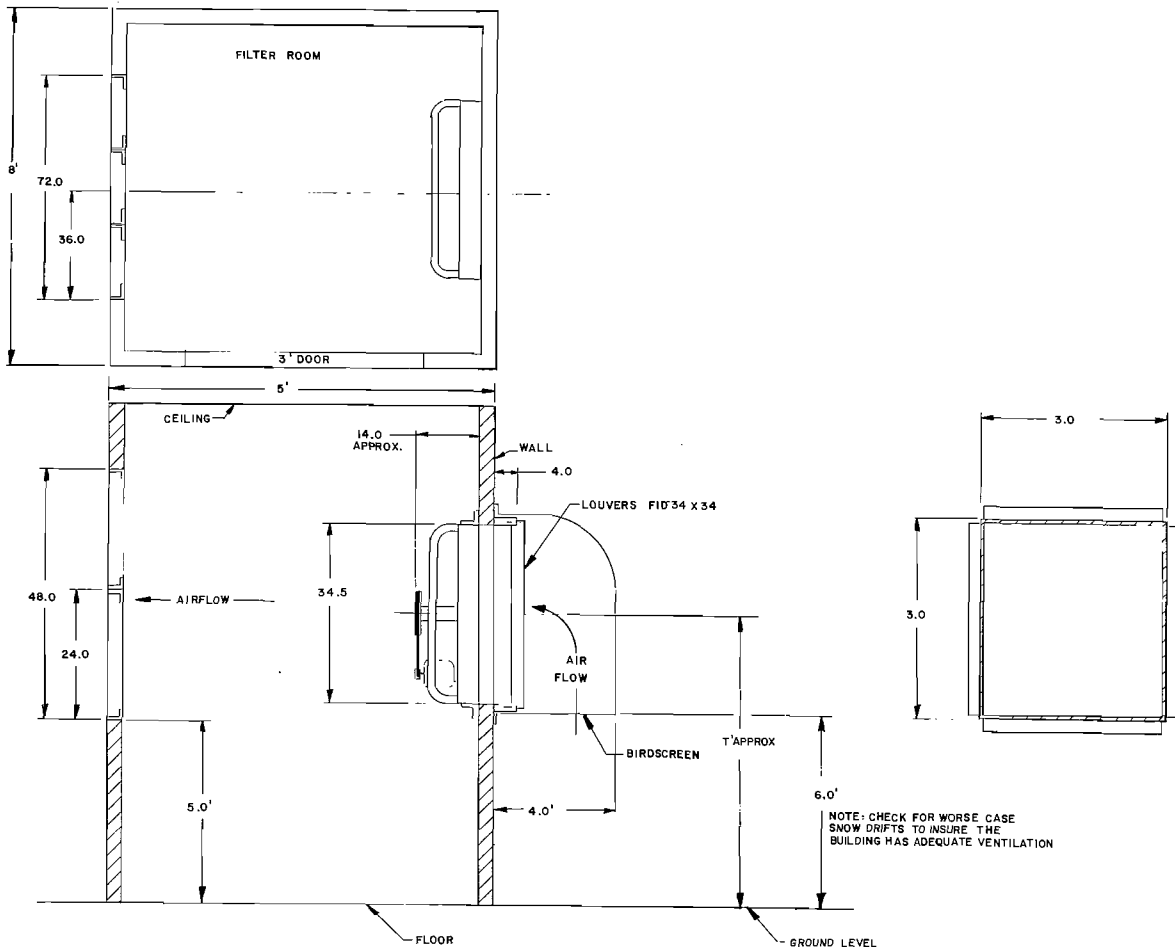

FIGURE 2-1. MW-50C3 OUTLINE DRAWING
(SHEET 3 OF 4)
839 6587 128

REAR ELEVATION

888-2213-0011
2-7/2-8



7. THIS TYPICAL TRANSMITTER SYSTEM HAS BEEN SIZED TO SLIGHTLY PRESSURIZE THE ROOM. IF ADDITIONAL COOLING IS REQUIRED FOR OTHER EQUIPMENT OR TO ACCOUNT FOR SOLAR BUILDING LOADS, CONSULT HARRIS OR QUALIFIED AIR CONDITIONING / VENTILATION CONSULTANT FOR ASSISTANCE.
6. THE EXHAUST BLOWER (POWERLINE 245BRE8H) HAS BEEN SIZED FOR 5324 CFM AT 3/8" WATER. THE ACTUAL EXHAUST FLOW AFTER CONSTRUCTION OF THE EXHAUST SYSTEM SHOULD BE ADJUSTED FOR A FLDW OF 5300 CFM AND 0" WATER AT THE EXHAUST PORTS OF THE TRANSMITTER.
5. THE INTAKE BLOWER (POWERLINE 30BV8H) IS SIZED FOR 5610 CFM AT 3/8" WATER. THE ACTUAL DESIRED MAKE-UP AIR REQUIREMENT IS 5200 CFM. AFTER THE SYSTEM IS CONSTRUCTED THE BLOWER CAN BE VARIED IN SPEED TO MEET THE ACTUAL SYSTEM REQUIREMENTS.
4. THE FILTER ROOM CAN BE EQUIPPED WITH A DWYER MINIHELIC GAUGE MODEL 5000-010-5" TO MONITOR THE FILTER DROP OR THE CLEANLINESS OF THE FILTER. THIS READING CAN BE USED FOR SCHEDULING FILTER CHANGES.
3. INLET FILTER BANK AT 5200 CFM FLOW RATE HAS A FACE VELOCITY OF APPROXIMATELY 433 FPM. THE TYPICAL PRESSURE DROP FOR CLEAN FILTERS IS APPROXIMATELY .1" WATER. THE TYPICAL PRESSURE DROP FOR A DIRTY FILTER IS APPROXIMATELY .5" WATER. THE FILTERS SHOULD BE CHANGED AT THIS POINT OR BEFORE.
2. AIR FILTERS (6) AMERICAN AIR FILTER COMPANY TYPE "5700" INDUSTRIAL FILTER 24"x24"x2". REMOVABLE FROM OUTSIDE THE FILTER ROOM. MOUNTING FRAMES ARE ALSO AVAILABLE FROM AMERICAN AIR FILTER CO.
1. THE WEATHERHOOD IS 18 GA GALVANIZED STEEL WITH AUTOMATIC BACKDRAFT DAMPERS (POWERLINE FID 34 x 34), AND A BIRDSCREEN OVER THE INLET. NOTE THE PREVAILING WIND PATTERNS SHOULD BE CONSIDERED BEFORE SELECTING WHICH WALL THE INTAKE SYSTEM IS MOUNTED ON. IF POSSIBLE, DO NOT PLACE THE INTAKE OR EXHAUST PORTS ON THE SIDE AGAINST THE PREVAILING WINDS.

FIGURE 2-1. MW-50C3 OUTLINE DRAWING
(SHEET 4 OF 4)
839 6587 128

888-2213-0011
2-9/2-10

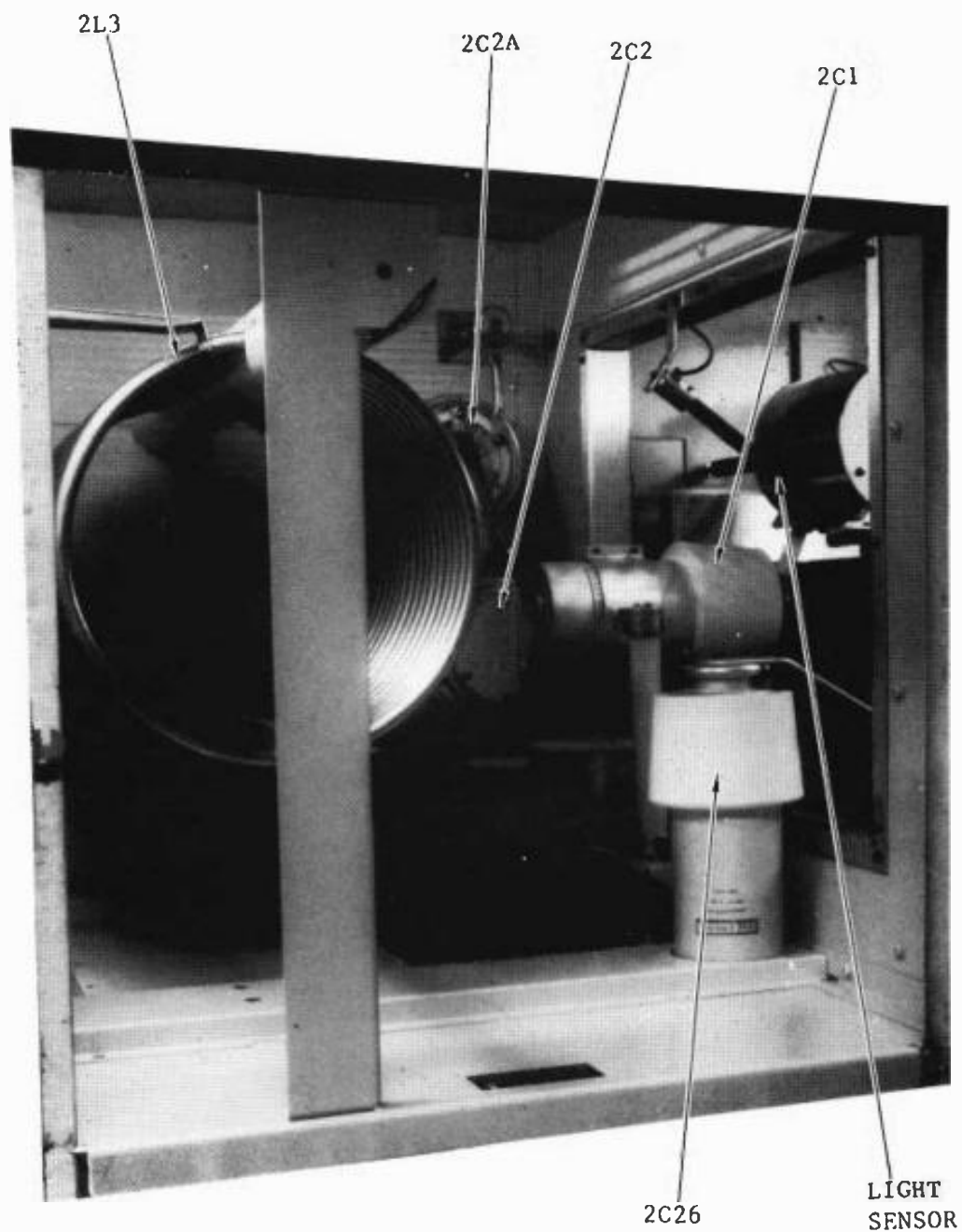

Figure 2-2. Cabinet 2 Upper Right Rear

888-2213-001

2-11

WARNING: Disconnect primary power prior to servicing.

www.americanradiohistory.com

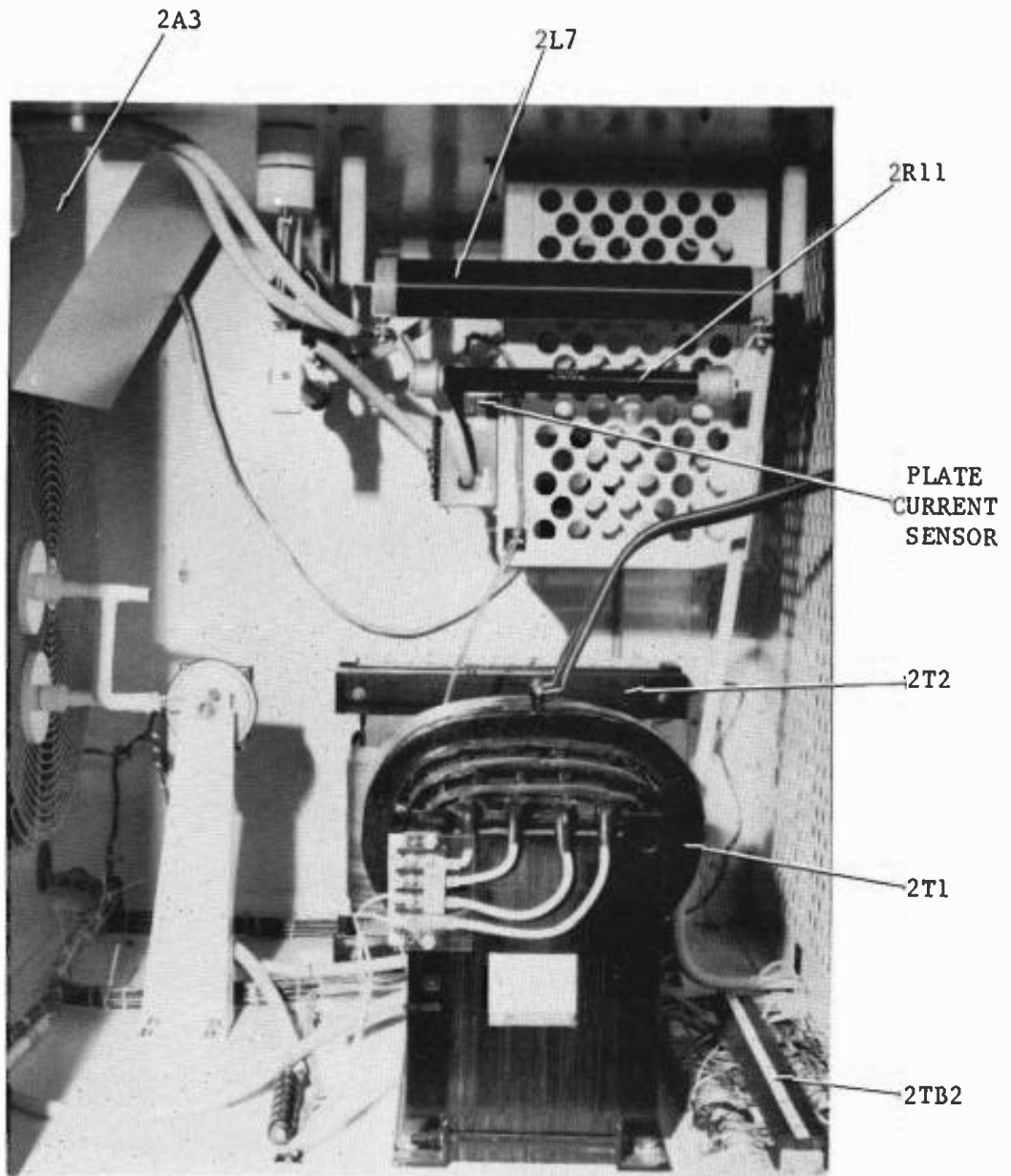

Figure 2-3. Cabinet 2 Lower Right Rear

2-17. Symbol numbers and descriptions are provided on each removed component corresponding to the schematic diagram, parts list, and packing list. Symbol numbers are also stenciled near the cabinet location of each removed item. Terminals and wires carry tags with information telling how to reconnect each item. Mounting hardware will be found either in small bags attached to each removed component or inserted in the taped holes where each component mounts.

2-18. The method of shipment determines which components are removed. The following components are removed from the MW-50C3 Transmitter when shipped by truck or rail freight.

a. Removed from Cabinet 1 Modulator Section.

<u>Item</u>	<u>Ref. Designator</u>	<u>Shown in Fig. No.</u>
Transformer	1T1	2-4
Transformer	1T4	2-4
Inductor	1L6	2-4
Capacitor	1C12	2-5

b. Removed from Cabinet 1 PA Section.

<u>Item</u>	<u>Ref. Designator</u>	<u>Shown in Fig. No.</u>
Transformer	1A9T3	2-7, 2-8, 2-9
Transformer	1A9T4	2-7, 2-9
Inductor	1A9L6	2-9
Inductor	1L3	2-8
Capacitor	1C1	2-9
Capacitor	1C2	2-2
Capacitor	1C2A	2-2
Capacitor	1C2B	2-2

c. Removed from Cabinet 2 Output.

<u>Item</u>	<u>Ref. Designator</u>	<u>Shown in Fig. No.</u>
Capacitor	2C1	2-2
Capacitor	2C2A	2-2
Capacitor	2C6	2-10
Capacitor	2C12	2-11
Capacitor	2C13	2-11
Capacitor	2C14	2-11
Resistor	2R7, 2R8	2-10, 2-11
	2R9, 2R10	
Transformer	2T1, 2T2	2-3, 2-12

d. For reference during assembly, the Oscillator is shown in figures 2-13 and 2-14, the control panel is shown in figure 2-15, and the High-Voltage Step-Start Assembly is shown in figure 2-16.

- e. Three 12 cc bottles of dashpot fluid are supplied with the transmitter which must be added as required to the oil bowls of the High-Voltage Step-Start Assembly magnetic overloads (3K3, 3K4, 3K5 figure 2-16). Adjustments are provided on the overload relays for both overload current and time delay. The overload value is set by rotating the armature on its threaded core. A tab aligns with markers on the armature to indicate the overload current. The amount of delay is determined by the quantity of oil in the dashpot. Only enough oil should be used as is required to stop the contactor from pumping when voltage is applied. If no pumping has occurred, no oil should be added.
- f. If relay adjustment is required, unsnap the oil bowl from the bottom of each relay and remove the armature and piston. The overload tripping current should first be set by instructions printed on the face of each relay so that the ac overloads just hold in when the transmitter is 100 percent modulated at a low frequency. Only enough oil should be added as is required to touch the rings on the bottom of the piston when the piston is placed in the dashpot. Replace the cores and snap the bowls back on the magnetic trip units.

WARNING

DO NOT CONNECT STATION PRIMARY POWER TO THE TRANSMITTER AT THIS TIME. USE A GROUNDING STICK TO DISSIPATE POTENTIAL FROM ALL TAPS, COMPONENTS, AND CONNECTIONS BEFORE TOUCHING THEM.

2-19. LIGHT SENSOR ASSEMBLY INSTALLATION

2-20. The Light Sensor Assembly is mounted on the top channel of the window between the PA/Modulator Cabinet and the Output Network Cabinet as shown in figure 2-2. Terminal board 1TB8 is mounted on the upperside of the top channel causing it to be hidden from view when the channel is in place. Terminal board 1TB8 is a junction for connecting the Indicator/Overload Assembly wiring to the Light Sensor wiring. Complete the following steps for installation:

- a. Connect wires to terminal board 1TB8. Refer to schematic 839 6587 037.
- b. Install top channel in place.
- c. Install Light Sensor in position shown.

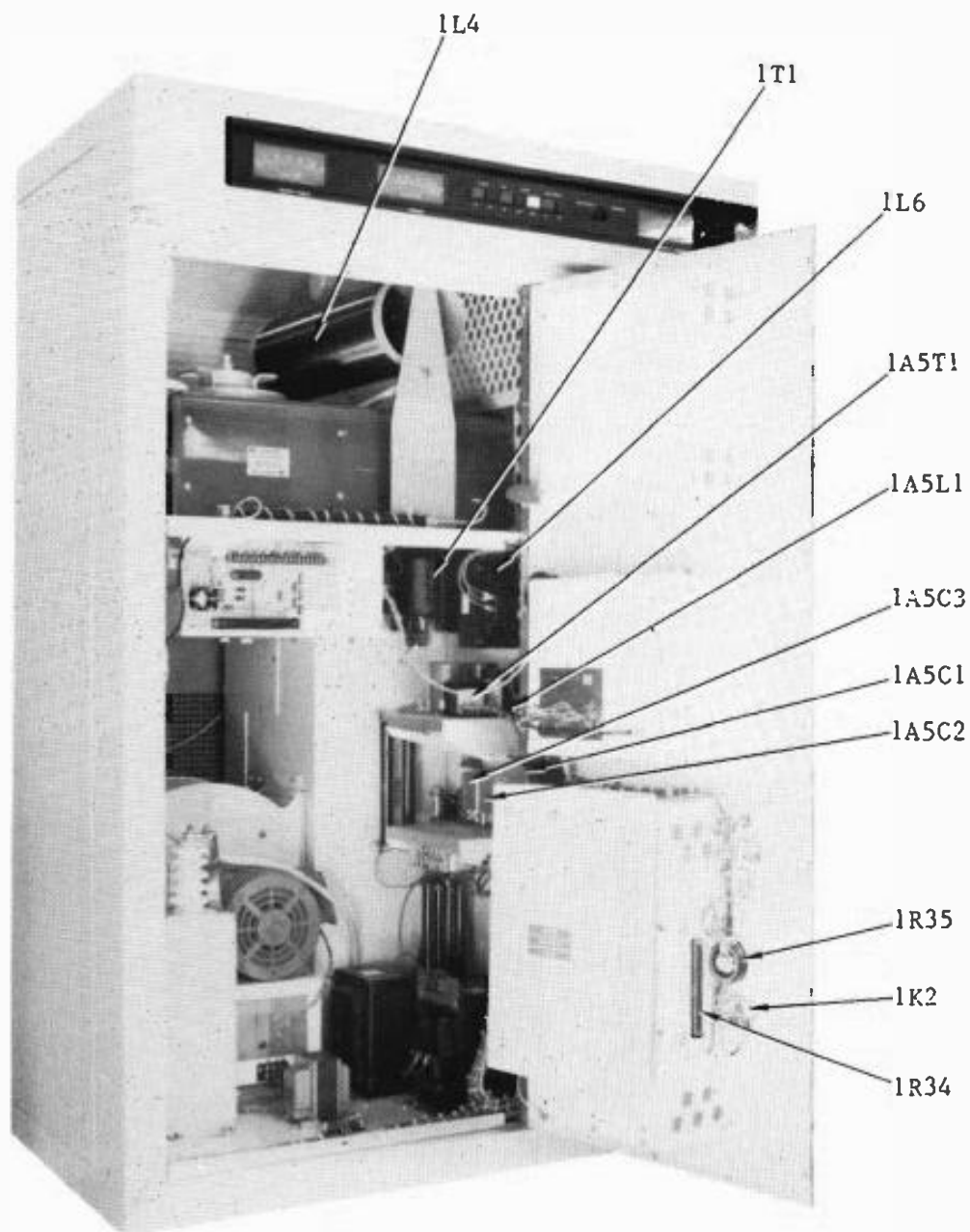

Figure 2-4. Cabinet 1 Lower Left Front and Door

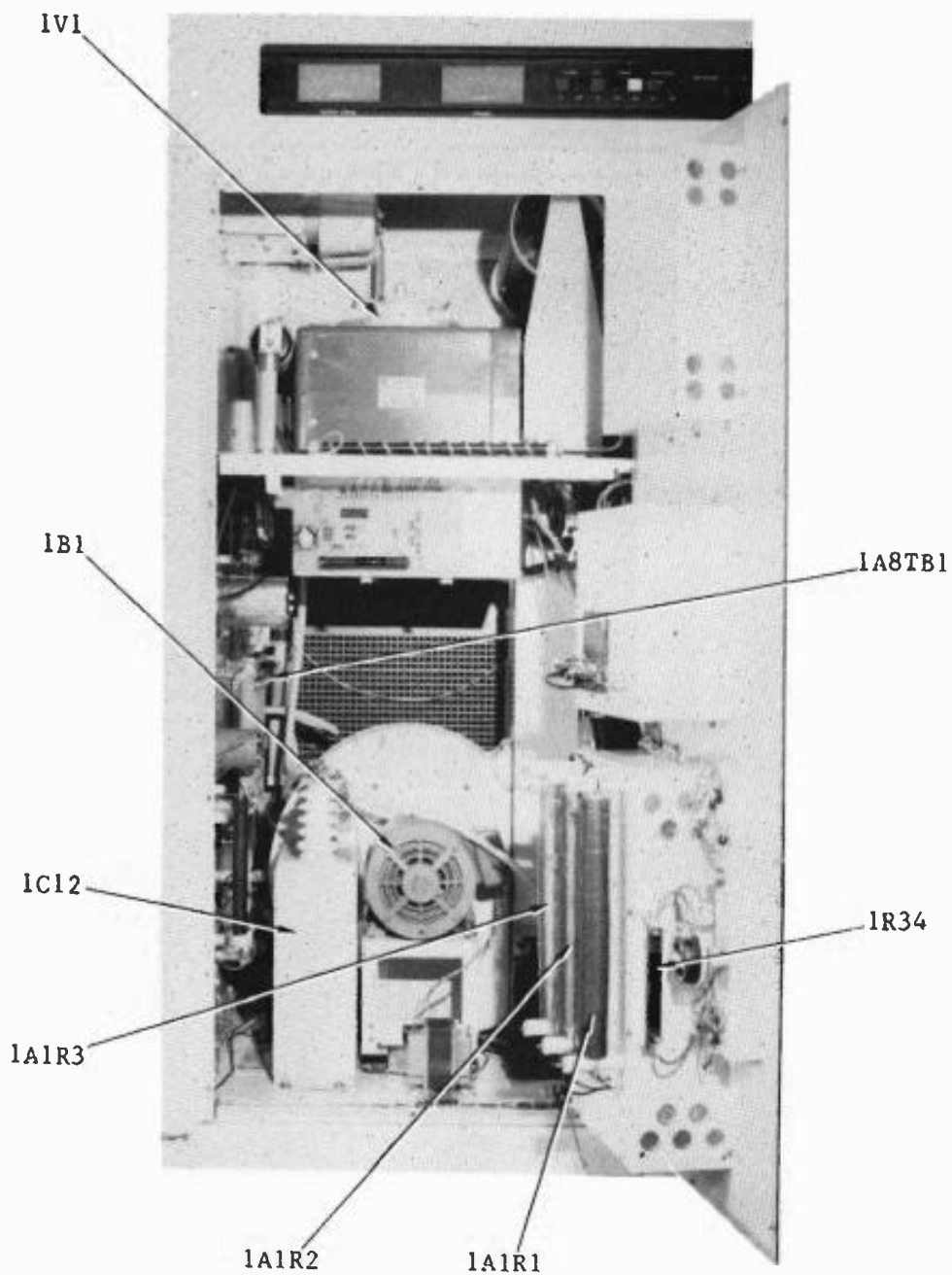

Figure 2-5. Cabinet 1 Left Front

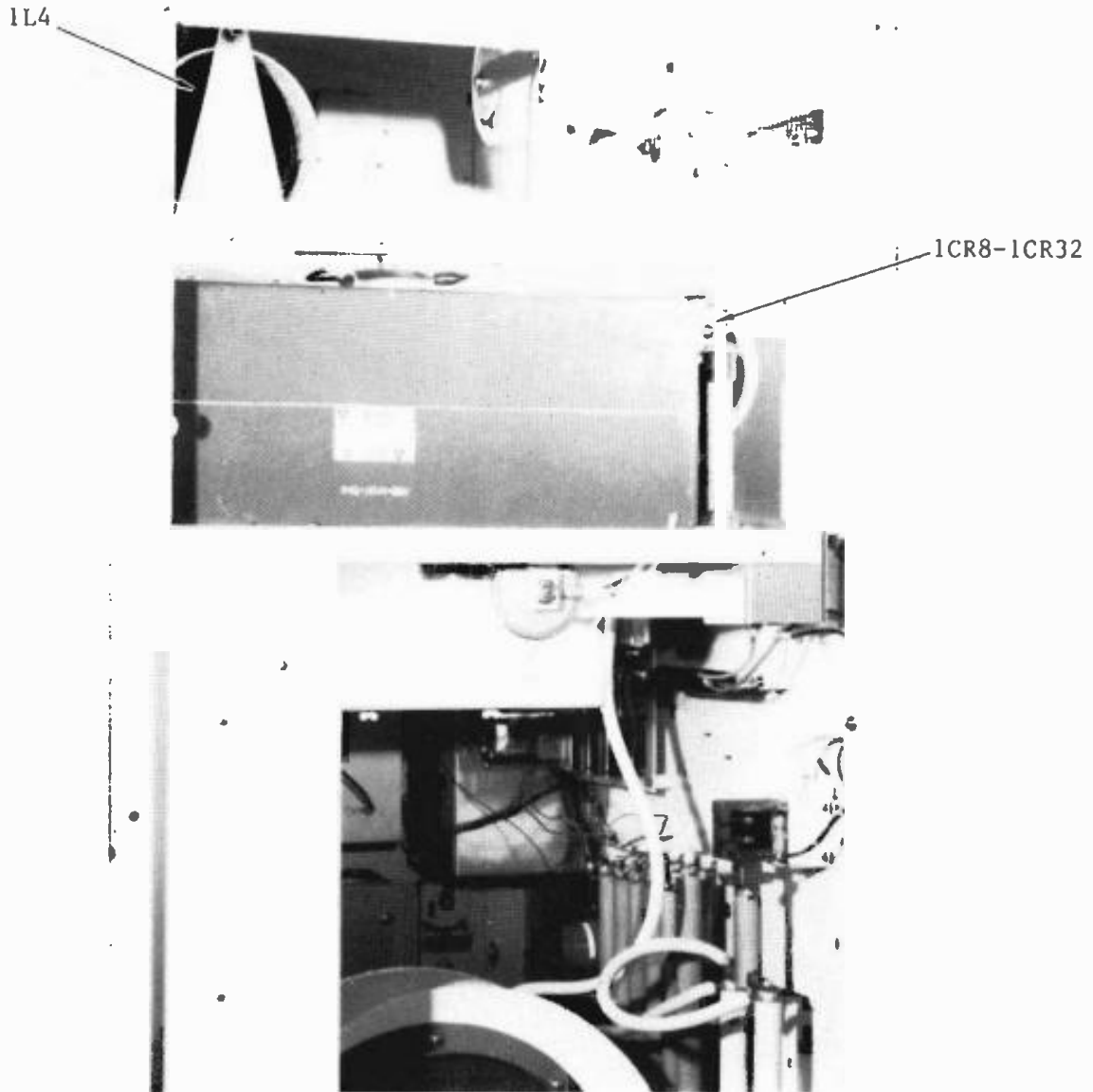

Figure 2-6. Cabinet 1 Upper Left Rear

888-2213-001

2-17

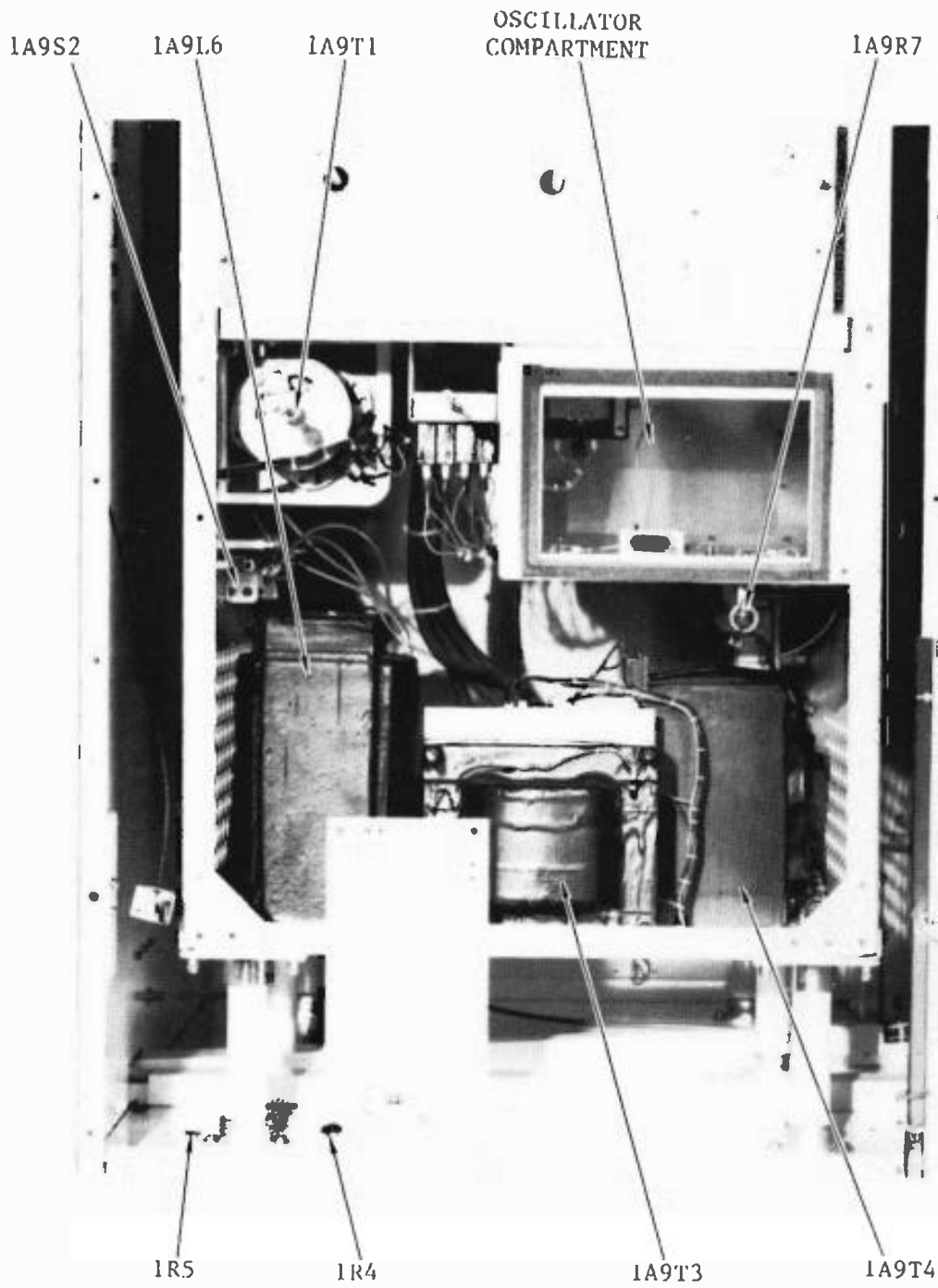

Figure 2-7. Cabinet 1 Lower Right Front

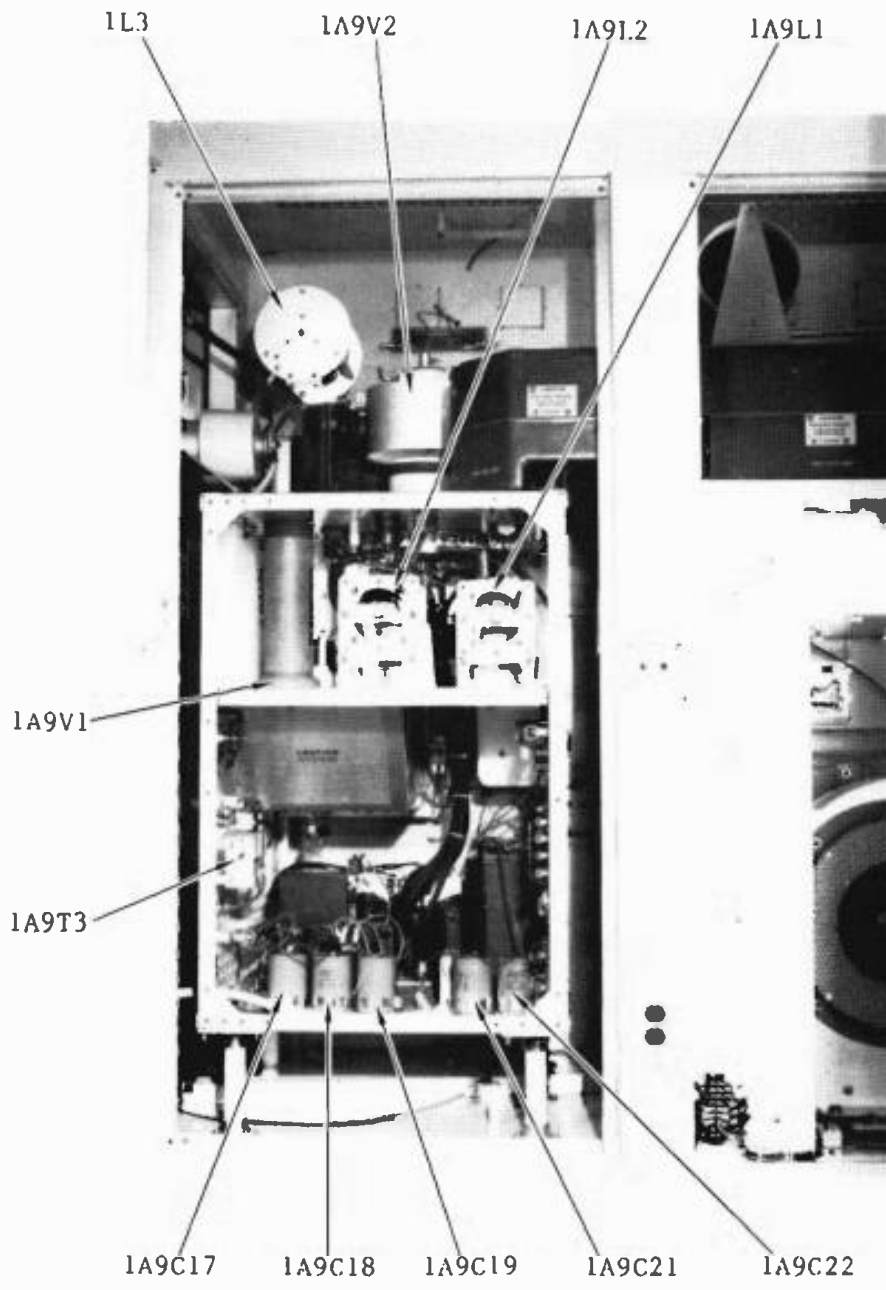

Figure 2-8. Cabinet 1 Left Rear

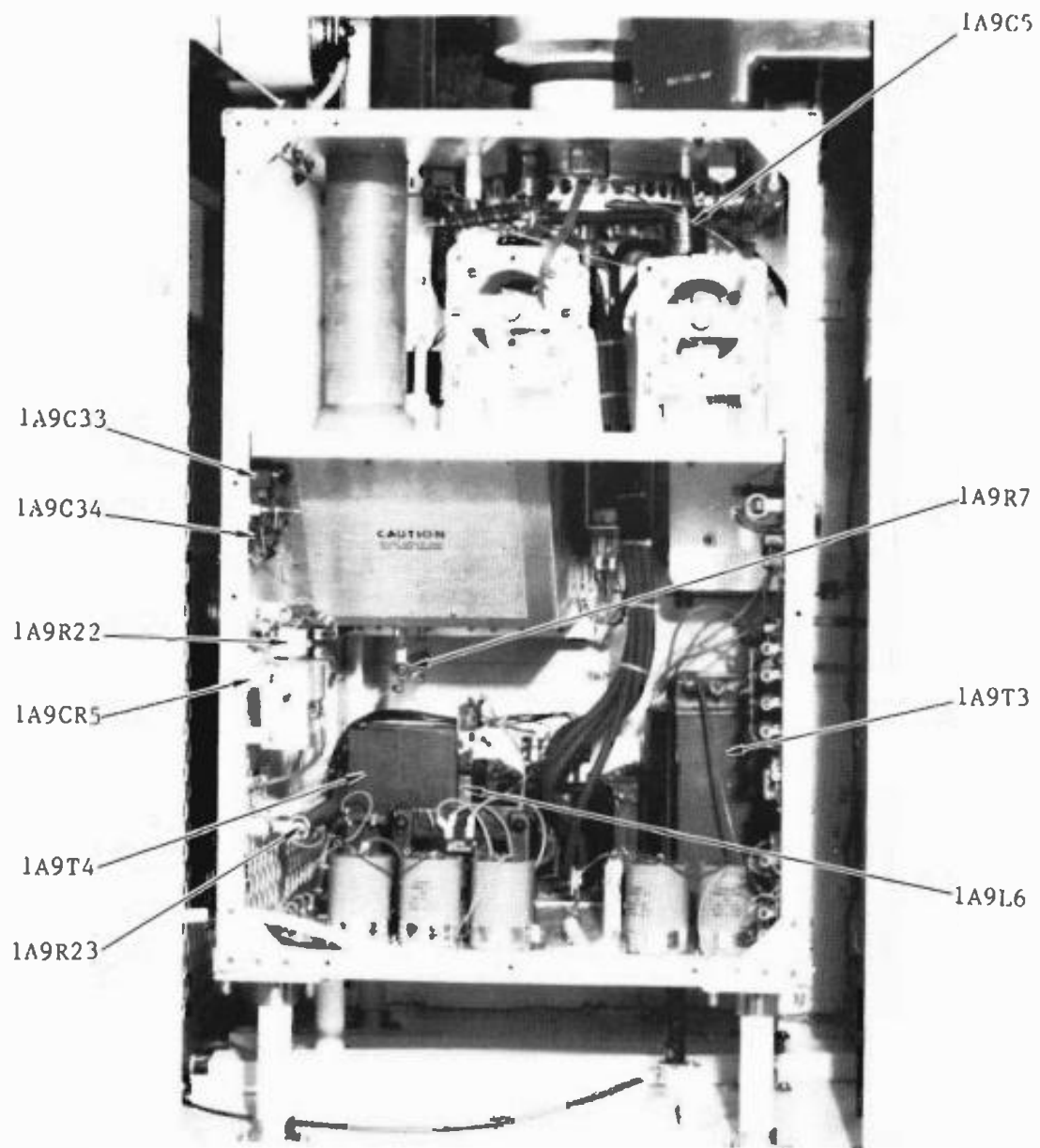

Figure 2-9. Cabinet 1 Left Rear

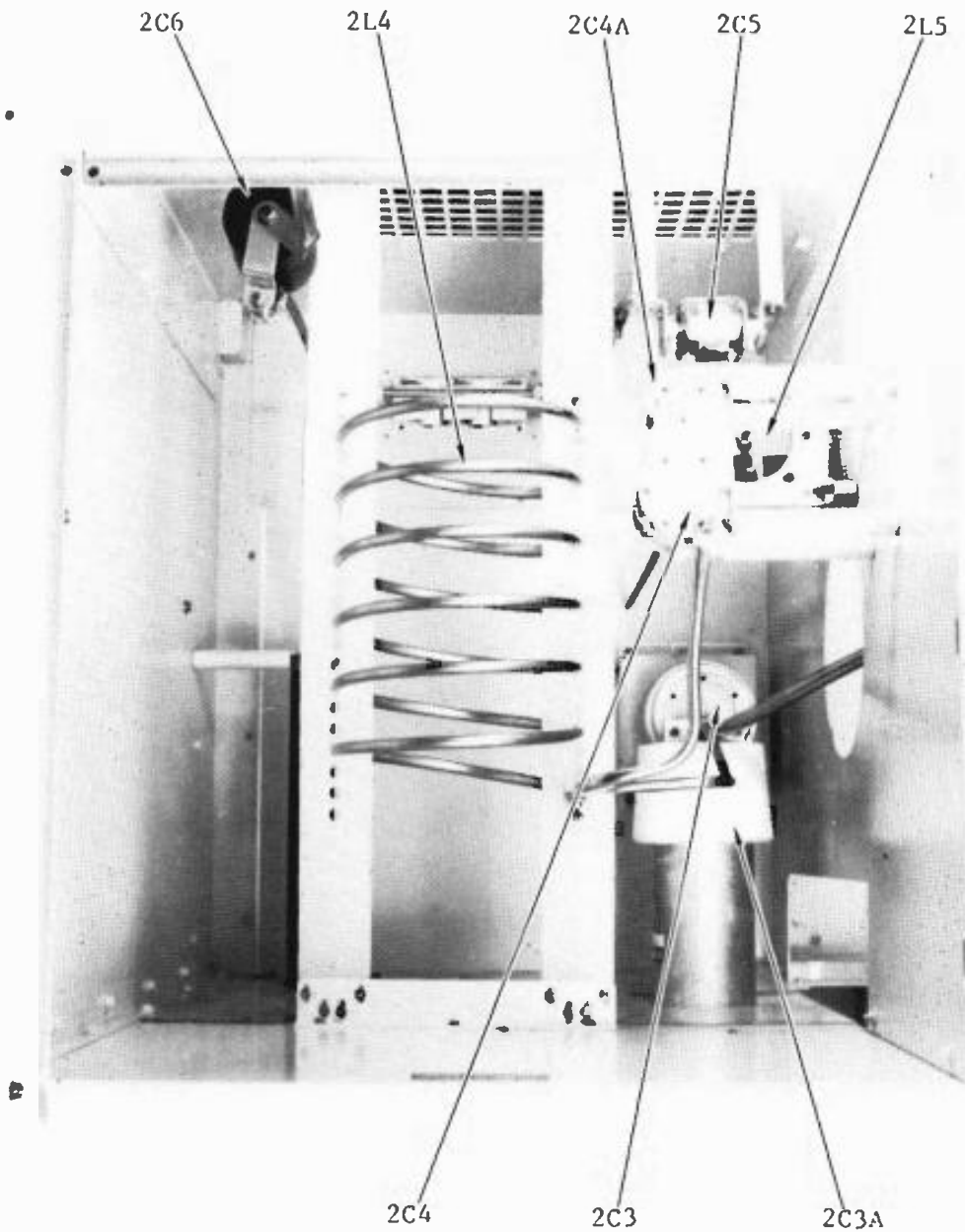

Figure 2-10. Cabinet 2 Upper Left Rear
(Sheet 1 of 2)

888-2213-001

2-21

WARNING: Disconnect primary power prior to servicing.

www.americanradiohistory.com

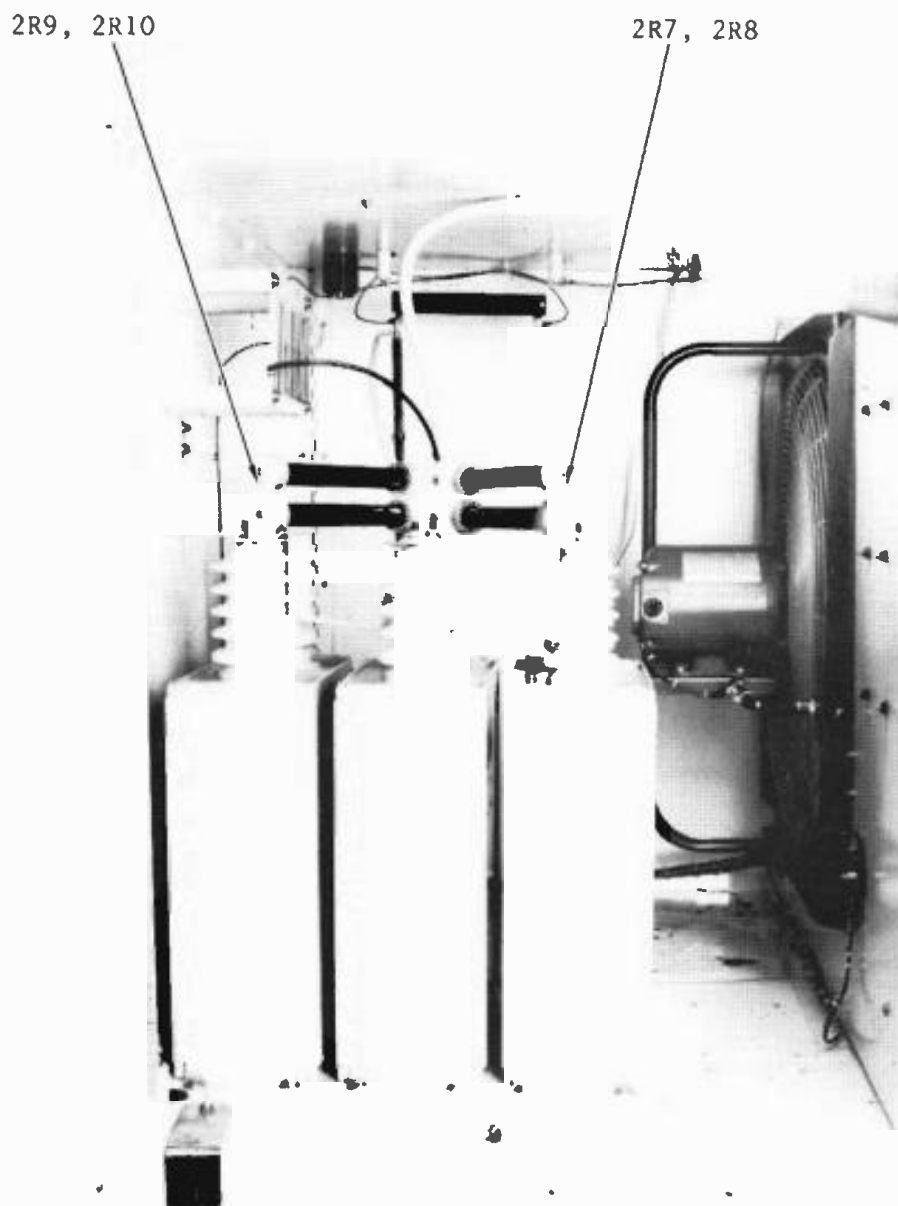

Figure 2-10. Cabinet 2 Lower Left Rear
(Sheet 2 of 2)

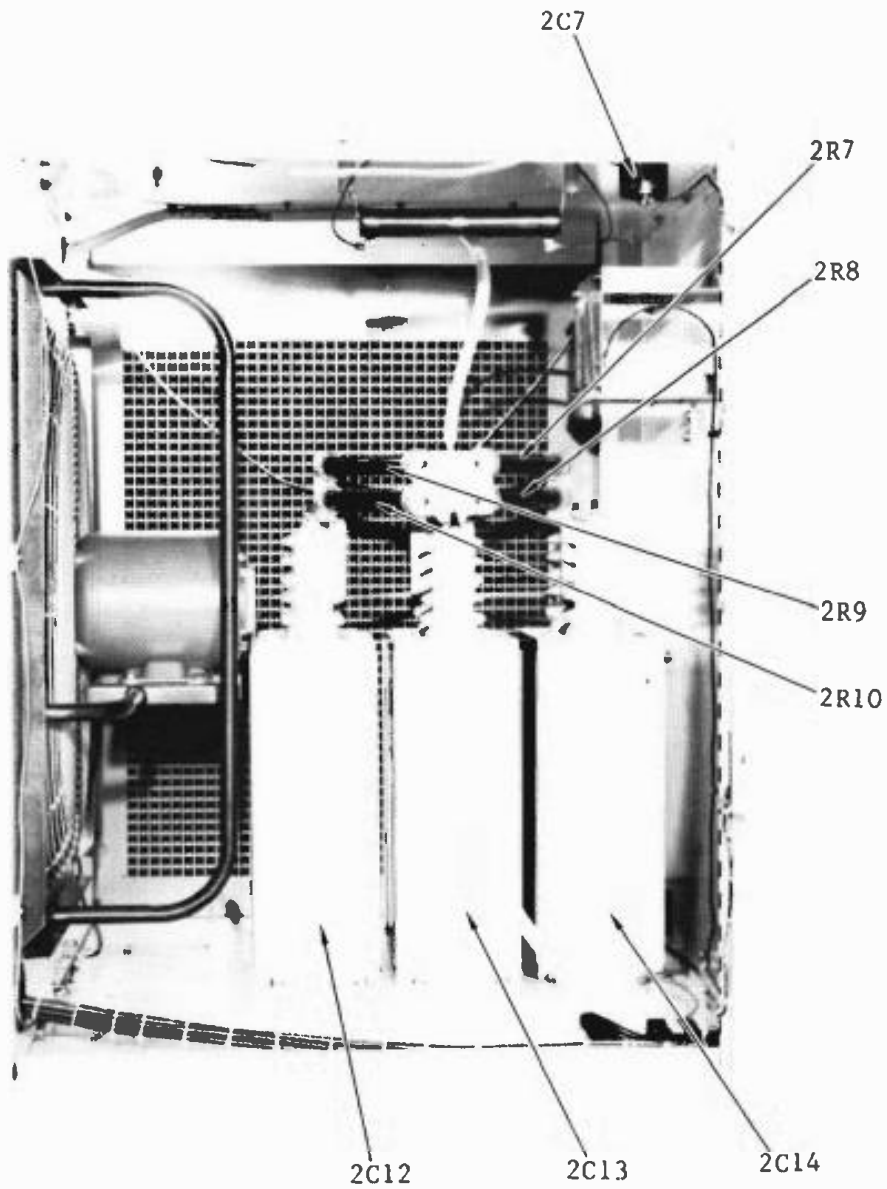

Figure 2-11. Cabinet 2 Lower Right Front

888-2213-001

2-23

WARNING: Disconnect primary power prior to servicing.

www.americanradiohistory.com

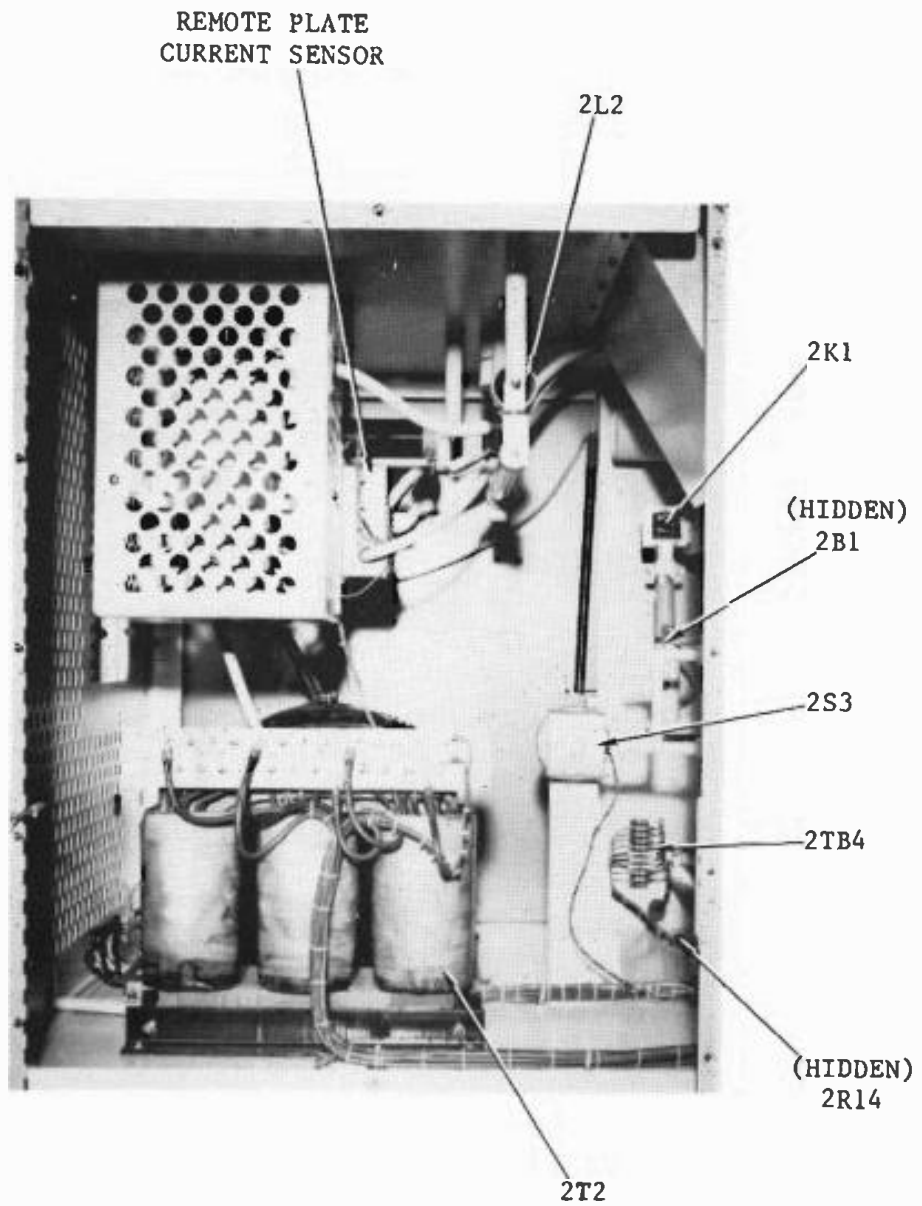

Figure 2-12. Cabinet 2 Lower Left Front

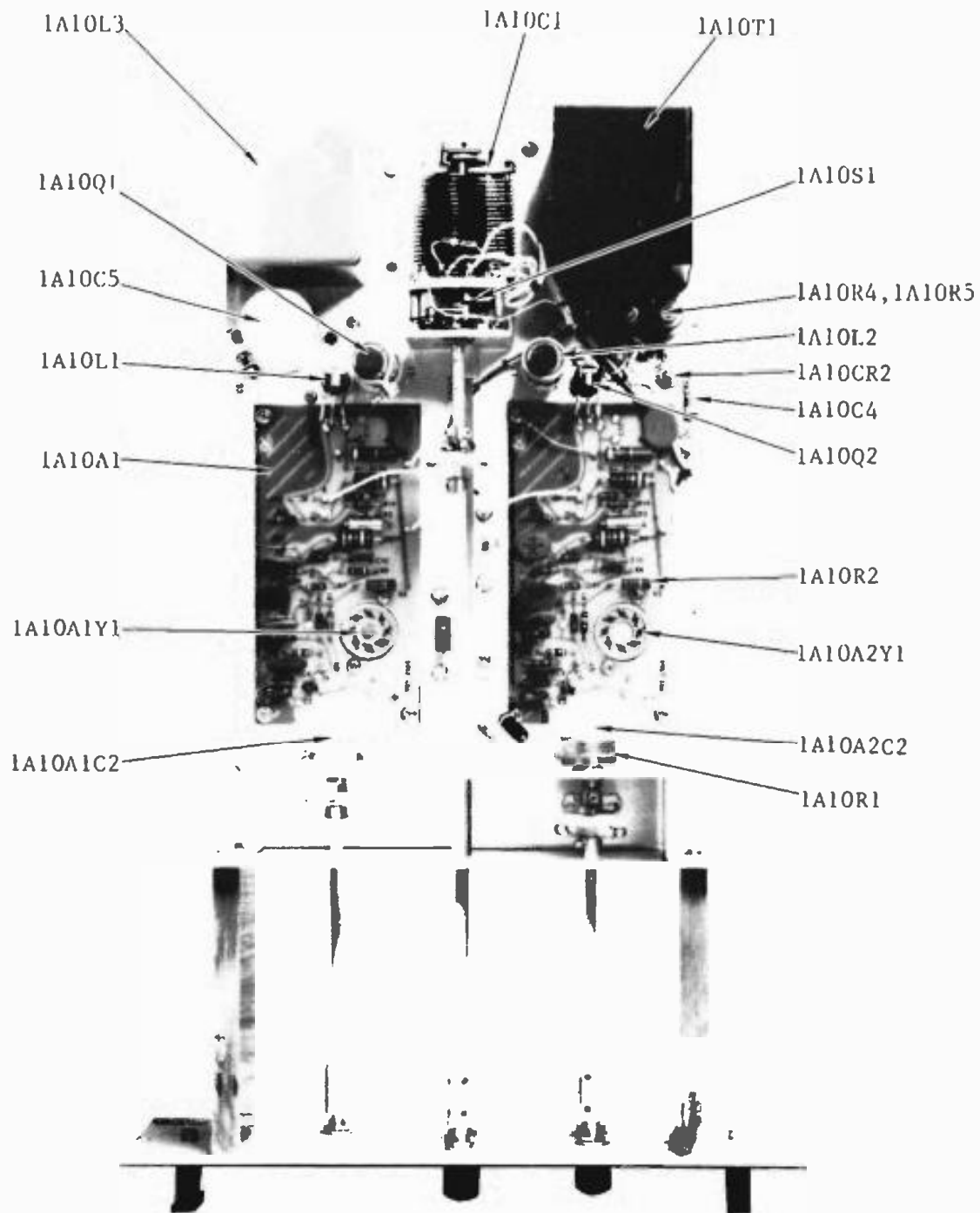

Figure 2-13. Oscillator Top

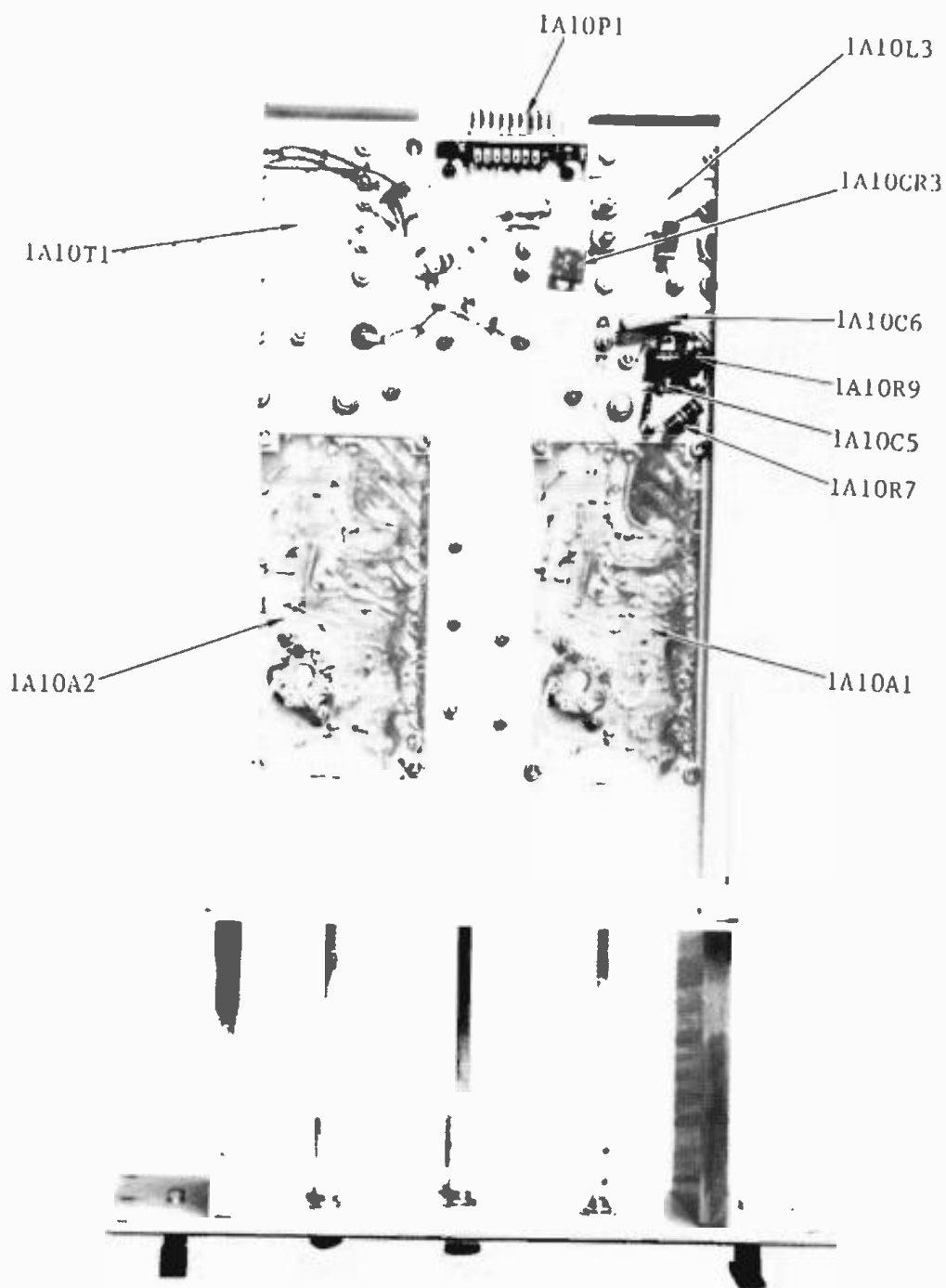

Figure 2-14. Oscillator Bottom

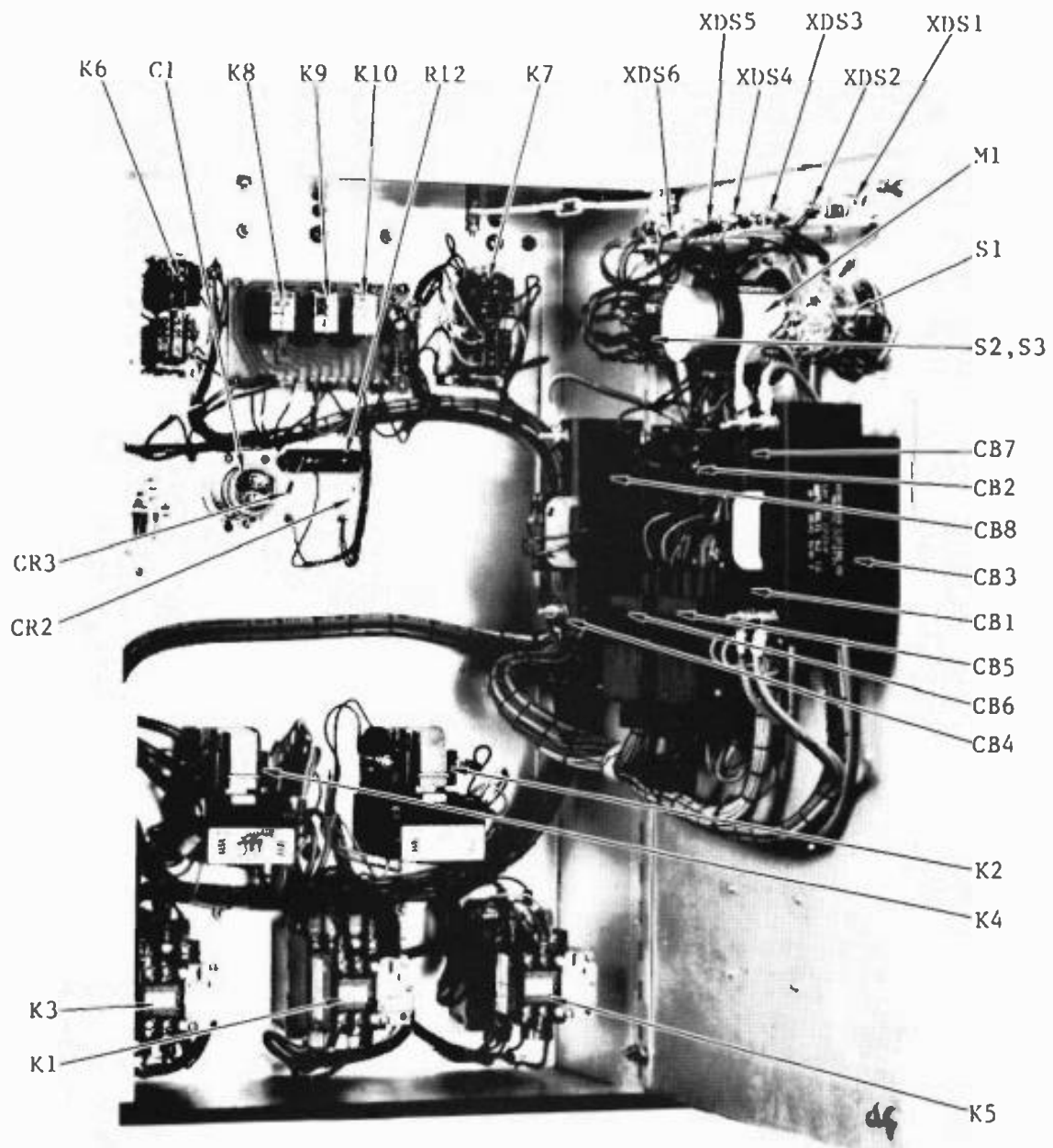

Figure 2-15. Control Panel

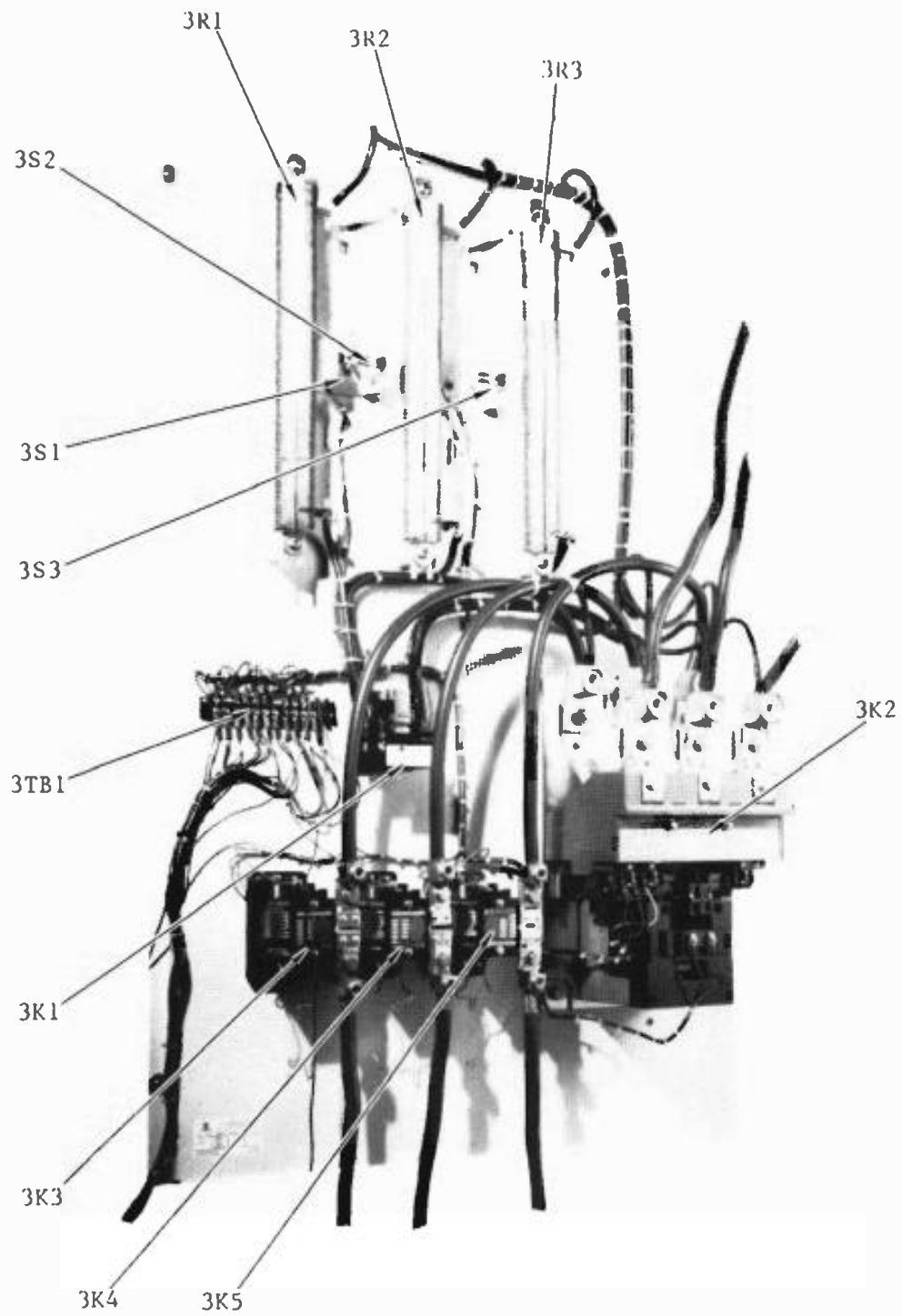

Figure 2-16. High-Voltage Step-Start Assembly

2-21. Modulator Tube 1V1 (4CX35000C) must be installed from the front of the transmitter (refer to figure 2-5). RF Driver Tube 1A9V1 (4CX1500A) and RF Power Amplifier tube 1A9V2 (4CX35000C) are installed from the rear of the transmitter (refer to figure 2-8).

2-22. RF Driver Tube (4CX1500A) must be slowly inserted into the socket until the tube seats and then rotated about 1/4-turn clockwise in the socket (refer to figures 2-5 and 2-8). The plate connector is then placed on the tube cap and tightened. Install the chimney on the tube.

2-23. Modulator Tube 1V1 (4CX35000C) is installed through the front access door (refer to figure 2-5) using the following procedure:

- a. Remove upper cover from air duct.
- b. Remove lower cover from air duct.
- c. Tighten the wing nut at the bottom of the socket so that the fitting in the tip of the socket is snug against the bottom of the socket. This will make it easier to place the tube in the slot of the center pull-down pin.
- d. Note the tube base and align the base to fit in the center slot when the tube is placed in the socket.
- e. With hands under the cooling fins, pick up the tube and gently ease it into the socket.
- f. Rotate the tube slightly back and forth until the tube slides down into the slot of the center pull-down pin.
- g. Loosen the large wing nut at the bottom of the socket while attempting to rotate the center pin clockwise as viewed from the socket base. When the wing nut is properly loosened, the center pin will turn about 1/8-turn clockwise.
- h. Hold the pin while tightening the wing nut. The tube will move down into the socket about 1/4-inch.
- i. After the wing nut is tightened, check the tube. It should be held firmly in the socket.

CAUTION

ENSURE AIR HOSE IS CONNECTED TO THE CENTER PIN AT THE BOTTOM OF THE TUBE SOCKET. THE TUBE CAN BE DESTROYED BY HEAT IF THE AIR HOSE IS NOT CONNECTED.

- j. Connect air hose to center pin at the bottom of the tube socket.
- k. Replace cover at the bottom of the tube socket.
- l. Install the top air duct panel and tighten the quarter-turn fasteners on the panel and plate ring.

2-24. Power Amplifier Tube 1A9V2 (4CX35000C) is installed using the same procedure used for the Modulator Tube, except that it is installed from the rear of the transmitter (refer to figure 2-17).

CAUTION

CHECK FOR PROPER PULL-DOWN TIGHTNESS.
ENSURE AIR HOSE IS CONNECTED TO CENTER
TUBE SOCKET PIN. ENSURE AIR DUCT COVER
IS INSTALLED AND FASTENERS ON DUCT AND
PLATE RING ARE TIGHTENED.

2-25. CONNECTIONS BETWEEN CABINETS

2-26. Terminal board 2TB2, which has 30 terminals, is located in Cabinet 2 along the bottom edge that matches up with Cabinet 1 (refer to figure 2-18). This terminal board connects the internal wiring of each cabinet together. The wires from Cabinet 1 are removed from the terminal board and tagged for easy reconnection. These connections are shown on figure 2-19. Reconnect them as indicated.

2-27. Two white 100kV high-tension wires must be connected after the cabinets have been joined. Refer to figures 2-2 and 2-3.

- a. In Cabinet 1, a 100kV wire laying on the base toward the front of the transmitter is terminated at capacitor 1C12 in the modulator section. Connect this wire to the end of coil assembly 2L7 closest to the edge of Cabinet 2.
- b. The second high-tension wire to be connected is in Cabinet 2 with one end terminated at the top of inductor 2L1. The loose end should be connected to the plate side of capacitor 2C1.
- c. In the back of the meter panels at the top, route the coaxial cable from the power coupler through the grommet and connect to terminal board 1TB10 (connect according to the tags on the cable).
- d. Feed the audio feedback cable through the grommets and connect to the feedback board (connect according to the tags on the cable).

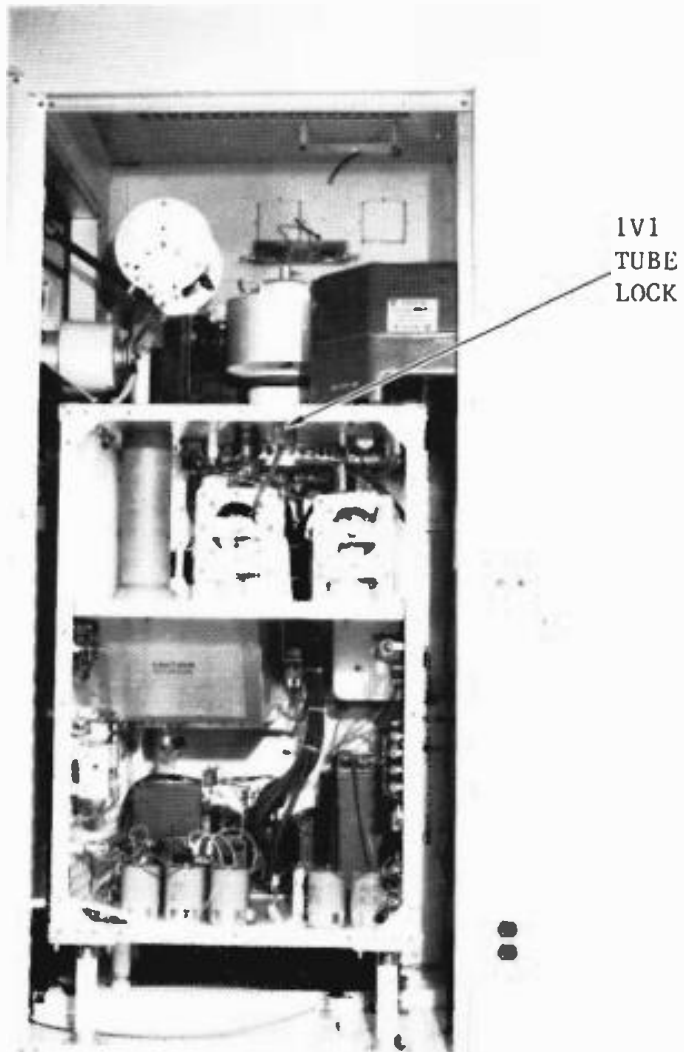
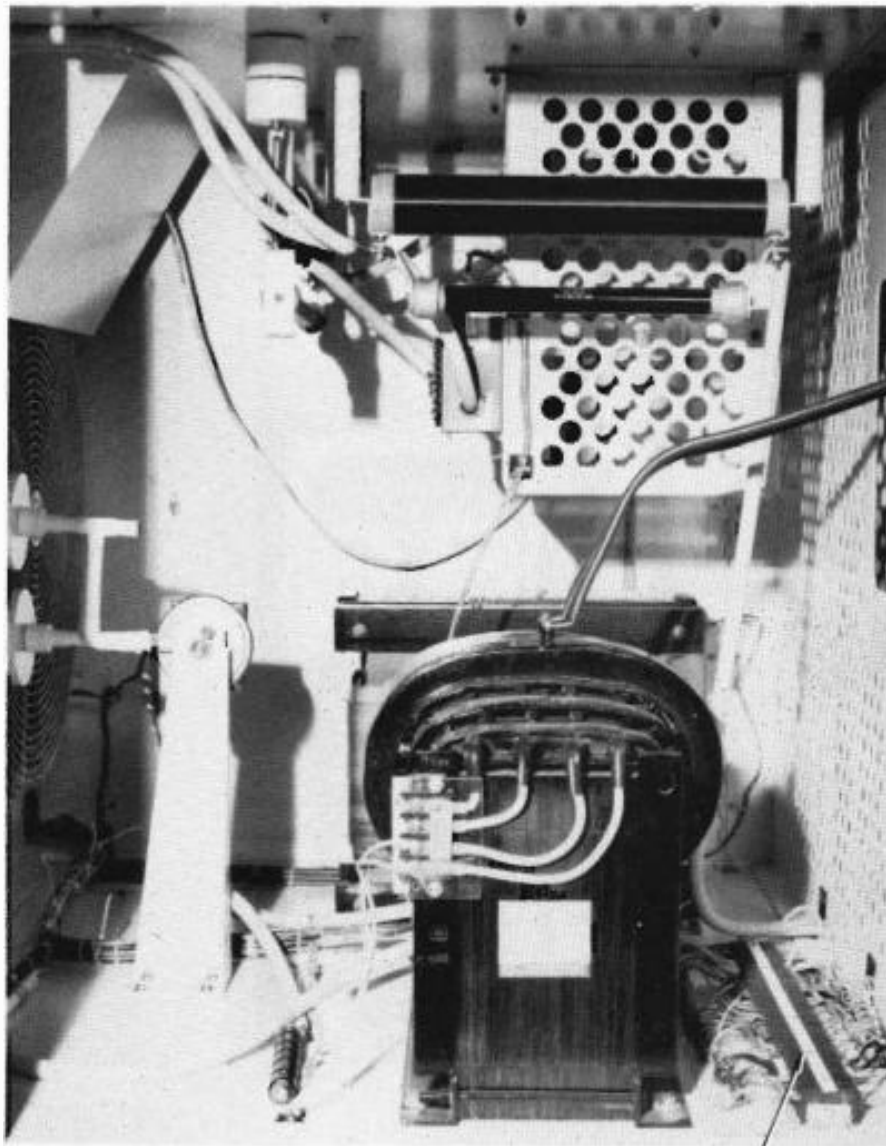

Figure 2-17. Modulator

888-2213-001

2-31

WARNING: Disconnect primary power prior to servicing.



2TB2
TERMINAL BOARD

Figure 2-18. Cabinet 2 Lower Right Rear

CABINET NO. 2 GROUND STUD

14

1	1
2	2
3	3
4	4
5	5
6	6
7	23
8	24
9	46
10	47
11	48
12	62
13	63
14	66
15	67
16	74
17	75
18	81
19	82
20	-
21	-
22	281 SHIELD
23	281 COND.
24	284
25	283
26	282
27	244 COND.
28	244 SHIELD
29	260 COND.
30	260 SHIELD

2TB2

Figure 2-19. Wiring Between Cabinet 1 And 2

WARNING: Disconnect primary power prior to servicing.

2-28. EXTERNAL CONNECTIONS

2-29. The following external connections must be made. Wiring information is shown in figure 2-20.

CAUTION

THIS EQUIPMENT IS DESIGNED FOR CONNECTION TO A CLOSED DELTA, WYE THREE-PHASE PRIMARY POWER SERVICE.

- a. Primary ac power is 3-phase, 380/460V, 50/60 Hz Primary line, as purchased. Two main ac entrance boxes are required (to be supplied by the customer). One 30-ampere, 3-phase, fused disconnect provides primary ac control for the transmitter. The second disconnect, 200-ampere, 3-phase, fused, allows primary ac voltage control of the High-Voltage Power Supply. Wire size is noted on figure 2-20. Primary control is recommended for safety so the transmitter can be checked with complete assurance that no high voltage will be present.

WARNING

DISABLE STATION PRIMARY POWER TO TRANSMITTER USE GROUNDING STICK TO DISSIPATE POTENTIAL FROM ALL TAPS, CONNECTIONS, AND COMPONENTS BEFORE TOUCHING THEM.

- b. Solidly connect the power supply case to earth ground. Use the grounding stick provided in the junction box to short out all capacitors and terminals. Clip leads may be used during installation to connect terminals and components to each other and ground for safety. Install and connect ac input and dc output wires to the supply as shown in figure 2-20. Avoid installing wire entrance points close to high-voltage terminals. If used, ensure that the power factor correction capacitors are properly connected (refer to Appendix A).
- c. Connect the coaxial antenna output, on the top of Cabinet 2, to the Antenna, or Phasor if used, with 3-1/8-inch diameter coaxial cable.
- d. Connect the control wires to the High-Voltage Step-Start Assembly using number 16 wire.
- e. Connect the shielded cables.
- f. Connect the negative wire from the transmitter to the High-Voltage Power Supply using number 10 stranded wire.

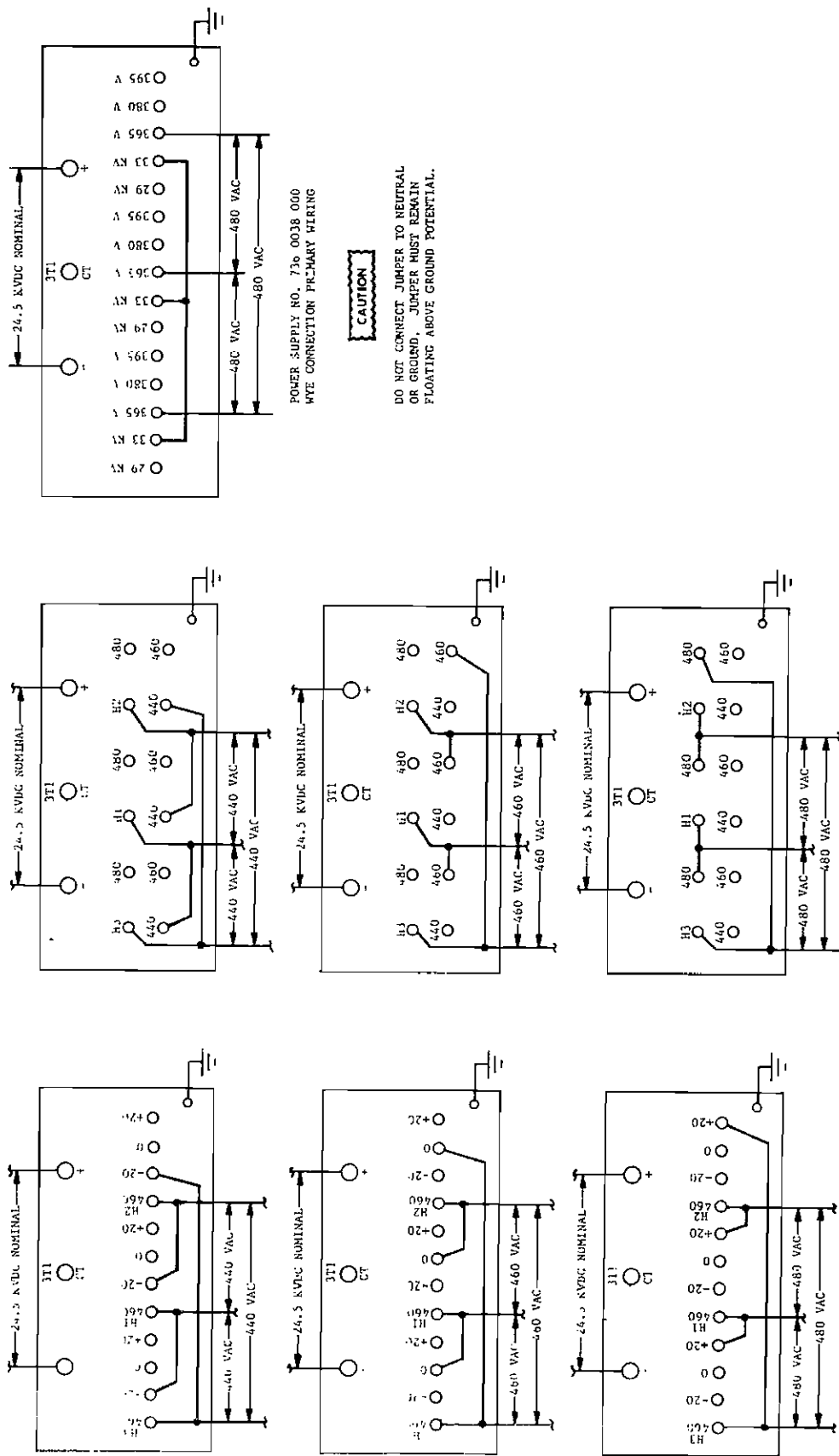

POWER SUPPLY NO. 736 0038 000
WYE CONNECTION PRIMARY WIRING

CAUTION

DO NOT CONNECT JUMPER TO NEUTRAL OR GROUND, JUMPER MUST REMAIN FLOATING ABOVE GROUND POTENTIAL.

POWER SUPPLY NO. 736 0033 000
DELTA CONNECTION PRIMARY WIRING

POWER SUPPLY NO. 736 0032 000
DELTA CONNECTION PRIMARY WIRING

Figure 2-20. Wiring Diagram (Sheet 2 of 3)

WARNING: Disconnect primary power prior to servicing.

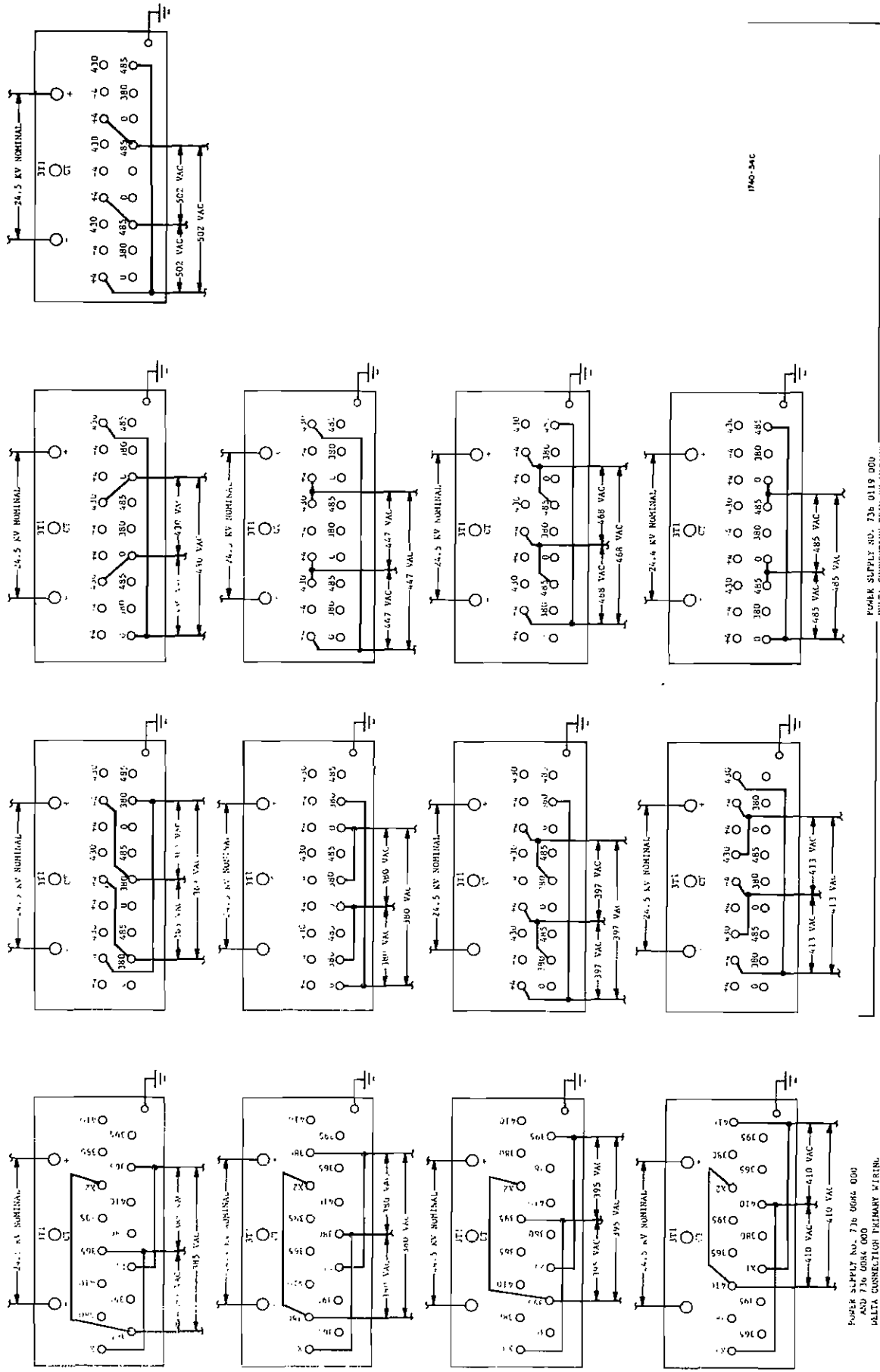

POWER SUPPLY NO. 776 0018 000
 DELTA CONNECTION PRIMARY WIRING

POWER SUPPLY NO. 776 0045 000
 AND 776 0084 000
 DELTA CONNECTION PRIMARY WIRING

Figure 2-20. Wiring Diagram (Sheet 3 of 3)

888-2213-001

2-37

WARNING: Disconnect primary power prior to servicing.

- g. Connect the positive high-voltage wire from Cabinet 2 to the High-Voltage Power Supply center tap (CT). This connection will be used for initial testing and changed later.
- h. Connect the input audio line to Cabinet 1, terminals 1 and 2 of terminal board 1TB2. Terminal 3 is connected to ground.
- i. Connect the modulation monitor to BNC connector 1J1 located in the lower rear portion of Cabinet 1 near terminal board 1TB1. Use 75-ohm RG59/U coaxial cable for this connection.
- j. A transmitter ground stud is located in Cabinet 1. Ground the Cabinets, High-Voltage Step-Start Assembly, and the large power transformer case using copper strap. They all should be connected to the main station ground system.

2-30. CONNECTIONS TO REMOTE CONTROLS/MONITORS

2-31. Figure 2-20 provides information required for connection of remote control facilities and termination data required for installation of monitoring equipment. If remote control or monitoring capability is utilized, the following connections must be made to terminal board 1TB1.

- a. REMOTE FILAMENT ON/OFF. A contact continuously made between terminals 15 and 16 will turn filaments on and hold them on. Opening this contact will deenergize the filaments. A holding contact rated at five amperes, 120 Vac is required.
- b. HIGH VOLTAGE ON. A momentary contact between terminals 19 and 20 will turn on the high voltage after the filament step-start has cycled. A five-ampere, 120 Vac contact is required. This feature is also activated by the Automatic Return After Power Failure feature.
- c. HIGH VOLTAGE OFF. A momentary contact between terminals 21 and 22 will remove high voltage. A one ampere 12 Vdc contact between terminals 11 and 9 will raise power. The contacts must be rated at five amperes, 120 Vac.
- d. RAISE/LOWER POWER. A contact between terminals 11 and 10 will lower transmitter power. A contact between terminals 11 and 9 will raise power. The contacts must be rated at five amperes, 120 Vac.
- e. HIGH/LOW POWER OPERATION. A momentary contact between terminals 16 and 17 will provide transmitter operation at high power. A momentary circuit between terminals 16 and 18 will reduce output power to a predetermined low-power level. The contacts must be rated at one ampere, 120 Vac.

CAUTION

IF THE POWER IS TO BE REDUCED AT THE SAME TIME THAT THE STATION GOES DIRECTIONAL, BOTH HIGH/LOW POWER AND CARRIER OFF FUNCTIONS MUST BE CARRIED OUT SIMULTANEOUSLY. TRANSMITTER CARRIER IS NOT CUT DURING A HIGH/LOW POWER CHANGE.

- f. CARRIER OFF (EBS or Phasor Control). A contact between terminals 24 and 25 will turn off the PDM which removes carrier, high voltage remains on. Use a contact rated one ampere at 12 Vdc.
- g. AUTOMATIC RETURN AFTER POWER FAILURE. A momentary contact between terminals 14 and 15 will activate the auto return circuit. A contact rating of one ampere at 120 Vac is required.
- h. REMOTE PLATE CURRENT METERING. Sensed final amplifier plate current is available on terminals 26 and 27. A LEVEL SET control, a ZERO control, and an ADJ control are provided on the remote plate Current Sensor for calibration. The LEVEL SET control provides an adjustment to scale the output range to any desired level. The ZERO control sets the 0 Vdc output with no through current. The ADJ control sets the output range from 0 to 5 Vdc for the full scale through current (refer to figure 2-21). To adjust the sensor proceed as follows:
 - 1. Adjust LEVEL SET control to maximum clockwise.
 - 2. With no through current, adjust ZERO control counterclockwise until output is 0.000 Vdc. Slowly continue to adjust ZERO control until output dc is between 0.001 and 0.010 Vdc to ensure the output is in the active region with no through current.

WARNING

HIGH VOLTAGE IS PRESENT WHEN PA PLATE CURRENT IS PRESENT.

- 3. Apply full through current and adjust ADJ control (located on the side of the unit) for full scale.
- 4. Remote final amplifier plate voltage is compared in integrated circuit U1 on the Fault and Overload board and is available on terminals 23 and 24 of terminal board 1TB1.

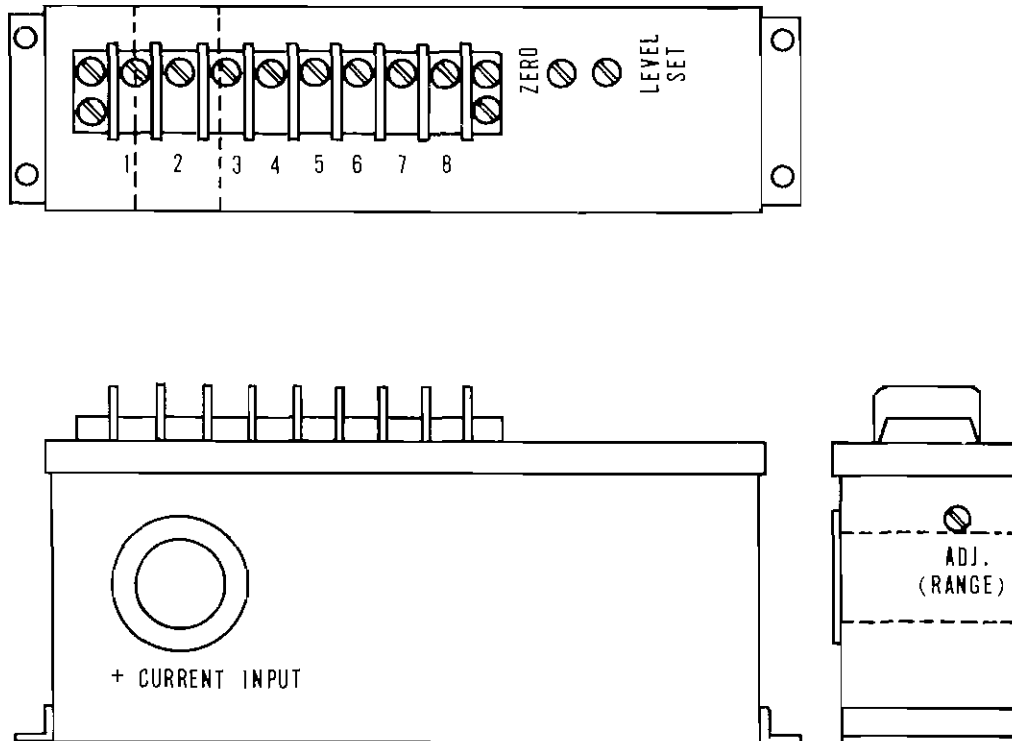

SPECIFICATIONS

AC1 MODEL 6011

D.C. CURRENT SENSOR

INPUT VOLTAGE RANGE: (105-135 VAC) 60-400 Hz

<u>THRU-CURRENT RANGES:</u>		<u>50 KV ISOLATION</u>	
0-10 MA	0-100 MA	0-1 AMP	0-10 AMP
0-20 MA	0-200 MA	0-2 AMP	
0-50 MA	0-500 MA	0-5 AMP	

OUTPUT: 0-5 VDC (adjustable scaling)

<u>ACCURACY:</u>	1% F.S.
<u>TEMP. COEF.:</u>	0.025 °C
<u>TEMP.:</u>	-20 to +71°C
<u>RESPONSE:</u>	500 MSEC (for average)
<u>OUTPUT IMPEDANCE:</u>	< 100 Ohms (to 5 MA max.)

TERMINATIONS

- | | |
|---------------|---------------|
| 1. VAC H1 | 5. OUTPUT (-) |
| 2. VAC Lo | 6. Spare |
| 3. Case Grd. | 7. Spare |
| 4. OUTPUT (+) | 8. Spare |

Figure 2-21. Remote Plate Current Sensor Adjustment

2-32. INITIAL TURN ON

2-33. Before proceeding with initial MW-50C3 Transmitter testing, ensure that the unit is completely installed, all parts are back in position and correctly wired, tubes are correctly positioned in their sockets, the transmitter is connected to a suitable rf load, all primary wiring is installed, the High-Voltage Power Supply is connected for approximately half-voltage output, audio input signal is provided, modulation and frequency monitors are connected, and all cabinets are free of debris and connected to station earth ground.

WARNING

ENSURE THAT THE MAIN BREAKERS IN THE PRIMARY CIRCUITS ARE SET TO THE OFF POSITION (30 AMPERE AND 200 AMPERE). USE A GROUNDING STICK TO DISSIPATE ANY RESIDUAL CURRENT BEFORE TOUCHING ANY COMPONENT.

2-34. The complete transmitter should be inspected at this time. Check the following:

- a. Make sure all connections at terminals boards and components are tight.
- b. Remove any extra hardware or wire lying within the cabinets and the High-Voltage Power Supply and tighten all nuts and bolts.
- c. Rotate blower and fan manually to be sure no obstructions are present.
- d. Check relay and solenoid armature operation manually. Make sure they all have free, unobstructed movement.
- e. All wires and cabling should be dressed properly.
- f. All air ducts and shielding should be in place.
- g. Use a vacuum cleaner and thoroughly clean the interior of the transmitter.
- h. Replace the transmitter doors after all inspection and all cleanup work has been completed. The doors have spring-held slip pins in each hinge to make installation a quick operation.
- i. BE SURE ALL THE TAPE THAT MAY HAVE BEEN INSTALLED FOR SHIPMENT AS ANTI-CHAFFING STRIPS BETWEEN ALUMINUM PANELS HAS BEEN REMOVED.

CAUTION

THE HIGH-VOLTAGE POWER SUPPLY SHOULD NOT BE SUBJECTED TO PERIODS OF STORAGE IN A HIGH-HUMIDITY ENVIRONMENT. IF THERE IS ANY QUESTION OF HOW OR WHERE THE SUPPLY HAS BEEN STORED OR IF THE STORAGE PERIOD HAS BEEN 30 DAYS OR LONGER, IT IS RECOMMENDED THAT BEFORE PROCEEDING THE SUPPLY BE TEMPORARILY OPERATED IN A WYE INPUT CONFIGURATION FOR A FEW HOURS.

2-35. MODULATOR CHECK

WARNING

DISCONNECT AND LOCK OUT STATION PRIMARY POWER TO TRANSMITTER. SET ALL TRANSMITTER CIRCUIT BREAKERS TO THE OFF POSITION.

- a. Remove the lower left front panel of Cabinet 2.

WARNING

USE A GROUNDING STICK AND TOUCH EACH TAP OF TRANSFORMER 2T2 TO DETERMINE THAT NO POTENTIAL IS PRESENT.

- b. Using clip leads, connect a voltmeter between terminal 22 and terminal 23. Place the voltmeter in front of the transmitter.
- c. Ensure all grounding sticks are in position of their interlocked holders. Close all doors and be sure all external interlocks are closed.

WARNING

LEAVE THE 200-AMPERE CIRCUIT BREAKER IN OFF POSITION.

- d. Apply station primary power to the transmitter.

- e. Set the 30-ampere circuit breaker to the ON position to apply ac power to the transmitter control circuits, fan, and blower.
- f. Check the external voltmeter reading. If the reading is 230 Vac ± 11.5 Vac the transformer 2T2 taps are correctly set. If the indication is other than 230 Vac ± 11.5 Vac, a tap change will be required.
- g. To change taps to obtain the correct voltage output, complete the following steps:
 - 1. Set all transmitter circuit breakers to the OFF position.

WARNING

DISABLE STATION PRIMARY POWER TO TRANSMITTER. SET ALL TRANSMITTER CIRCUIT BREAKERS TO THE OFF POSITION. USE A GROUNDING STICK AND TOUCH EACH TAP OF TRANSFORMER 2T2 (FIGURE 2-12) TO DETERMINE THAT NO POTENTIAL IS PRESENT.

- 2. If the voltmeter reading was lower than 230 Vac ± 11.5 Vac, change the secondary leads from taps 2, 9, 16, to 3, 10, 17.
- 3. If the voltmeter reading was higher than 230 Vac ± 11.5 Vac, change the secondary leads from taps 2, 9, 16, to 1, 8, 15.
- 4. Repeat steps b, c, d, e, and f, as necessary until the 230 Vac ± 11.5 Vac reading is obtained.

WARNING

DISCONNECT AND LOCK OUT STATION PRIMARY POWER TO THE TRANSMITTER. SET ALL THE TRANSMITTER CIRCUIT BREAKERS TO THE OFF POSITION. USE A GROUNDING STICK AND TOUCH EACH TAP OF TRANSFORMER 2T2 (FIGURE 2-12) TO DETERMINE THAT NO POTENTIAL IS PRESENT.

- h. Remove the clip leads and the external voltmeter. Replace the lower left front panel.
- i. Apply station primary power to the transmitter.
- j. Set the 30-ampere circuit breaker to ON to apply ac power to the transmitter control circuits, fan, and blower.

- k. Depress FILAMENT ON pushbutton switch. The blower and fan should operate and the AIR MALFUNCTION indicator should extinguish.
- l. If the AIR MALFUNCTION indicator remains illuminated, check the air flow at the rear door filters of Cabinet 1 and Cabinet 2. The air flow should be into the cabinets. If the airflow is out of either door filter, the rotation of the fan in Cabinet 1 or the blower in Cabinet 2 is reversed.

NOTE

If the AIR MALFUNCTION indicator remains illuminated after it is determined that fan in Cabinet 1 and blower in Cabinet 2 are rotating in the proper direction, the set point of the air interlock switch requires adjustment.

Rotate the adjusting screw (located in center of air switch mounting boss) counterclockwise in 1/2 turn increments until AIR MALFUNCTION indicator on front panel is extinguished when blower is operating.

- m. After determining which unit (fan or blower) has reverse rotation, correct the rotation problems as follows:
 1. Depress FILAMENT OFF pushbutton switch.
 2. Set the 30-ampere circuit breakers to the OFF position.
 3. DISABLE STATION PRIMARY POWER TO THE TRANSMITTER.

WARNING

DISCONNECT AND LOCK OUT STATION PRIMARY POWER TO THE TRANSMITTER. USE A GROUNDING STICK TO DISSIPATE ANY POTENTIAL FROM ALL COMPONENTS BEFORE TOUCHING THEM.

4. If the fan in Cabinet 2 has reversed rotation, interchange any two wires on fan terminal block 2TB3. Refer to figure 2-23 for the location of terminal block 2TB3.
5. If the blower in Cabinet 1 has reversed rotation, interchange any two wires on blower terminal block 1TB3.
- n. Apply primary power to the transmitter. Set the 30-ampere circuit breaker to the ON position to apply ac power to the transmitter control circuits, fan, and blower.

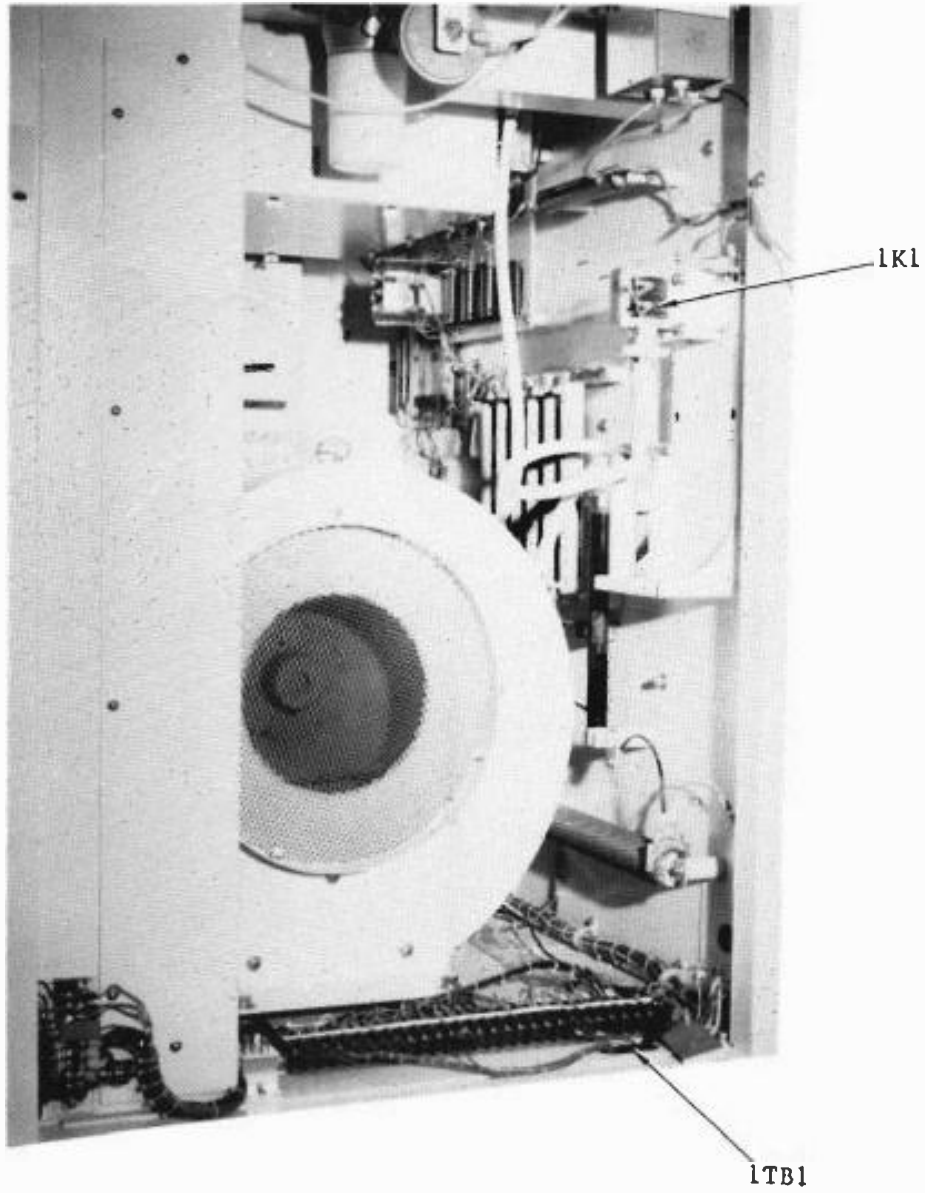

Figure 2-22. Cabinet 1 Lower Right Rear

888-2213-001

2-45

WARNING: Disconnect primary power prior to servicing.

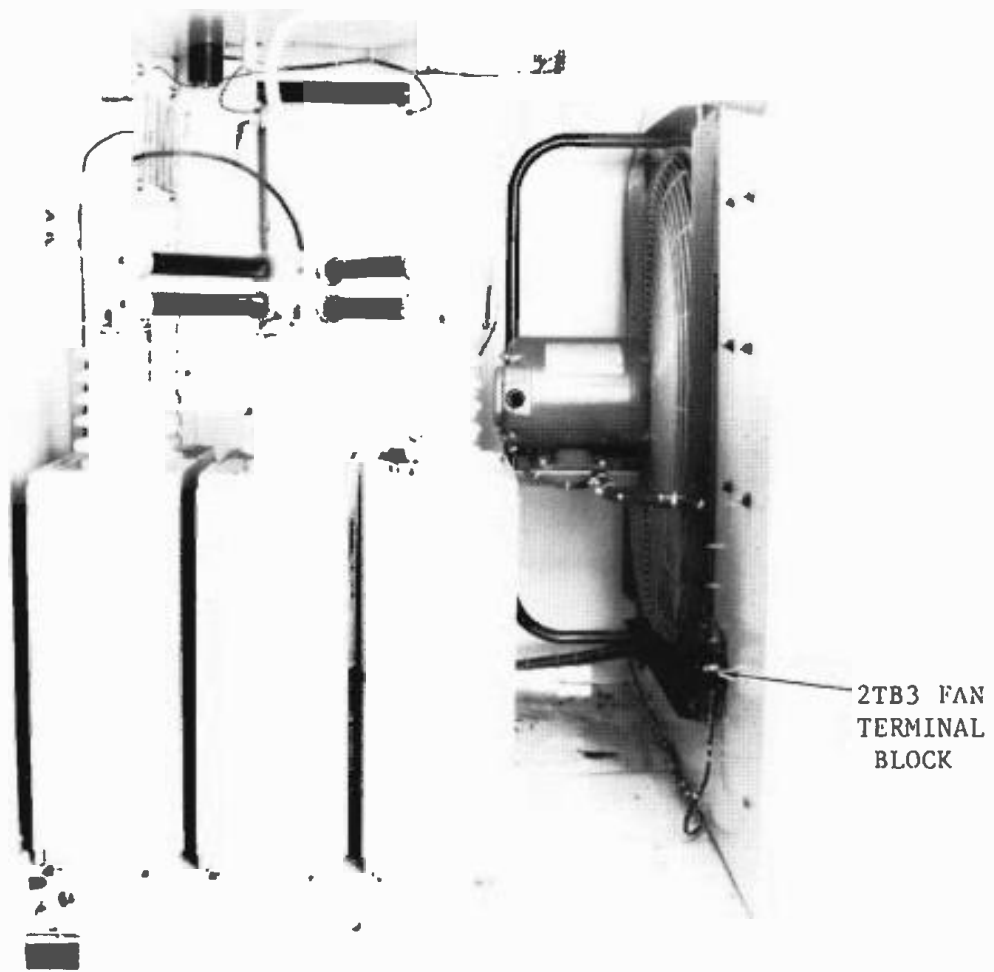

Figure 2-23. Cabinet 2 Lower Left Rear

- o. Depress FILAMENT ON pushbutton switch. The fan and blower should operate and the AIR MALFUNCTION indicator should extinguish after a few seconds.
- p. Set all remaining circuit breakers on the power control panel to the ON position. All switches remain off. After setting the last circuit breaker, the filaments should step-start ON. The second step will begin in about five seconds.
- q. Set filament voltage on the PA and modulator by adjusting the POWER AMPLIFIER FILAMENT ADJUST and MODULATOR FILAMENT ADJUST controls to obtain a 9.5 Vac indication on the FILAMENT Meter for each section.
- r. Open and close each door and ground stick interlock, one at a time. A DOOR or GND STICK SAFETY INTERLOCK indicator should illuminate and extinguish each time an interlock is violated and then restored.
- s. Close all doors and interlocks. FILAMENT ON indicator should illuminate. No SAFETY or MALFUNCTION INTERLOCKS indicators should be illuminated.
- t. Check the PA meter panel for a CIRCUIT BREAKER open indication. If a circuit breaker is open, depress CIRCUIT BREAKER PUSH TO RESET pushbutton switch located on the lower PA panel.
- u. Operate the PA MULTIMETER switch to the DRIVER GRID AMPS position. Peak the indicated current by adjusting the RF DRIVER GRID TUNE control located on the oscillator panel. The PA MULTIMETER should indicate above mid scale. Check operation of both oscillators and peak each oscillator with the RF DRIVER GRID TUNE control. Adjust PA screen protector control maximum CCW.
- v. Set the ISO ENCL B+ and 25kV switches to the OPERATE position.

WARNING

ENSURE MAIN AC (200 AMPERE) TO THE HIGH-VOLTAGE STEP-START ASSEMBLY IS OFF. THERE MUST BE NO HIGH VOLTAGE FOR THE FOLLOWING TESTS.

- w. Depress the POWER HIGH pushbutton switch/indicator. The switch/indicator should illuminate.
- x. Open the PDM panel (refer figure 2-24) and adjust high-power level control potentiometer R44 maximum counterclockwise. Depress HIGH VOLTAGE ON pushbutton switch/indicator. The switch/indicator should illuminate. The modulator MULTIMETER should indicate approximately as shown in Column 1.

	<u>Column 1</u>	<u>Column 2</u>
DRIVER SOURCE AMPS 0-3	1.2	0
DRIVER GATE VOLTS 0-30	11.5	0
DRIVER DRAIN VOLTS 0-1200	4.0	480.0
MOD GRID VOLTS 0-1200	400.0	0
MOD SCREEN VOLTS 0-1200	860.0	300.0
MOD SCREEN AMPS 0-3	1.45	3.0
AUX DRIVER AMPS 0-1.2	0.1	0.1
AUX DRIVER VOLTS 0-120	100.0	100.0

- y. Adjust high-power level control potentiometer R44, on the PDM chassis, maximum clockwise. The modulator MULTIMETER indications should be approximately as shown in Column 2. Meter transitions should be smooth without jitter or jump. If the indications are satisfactory, adjust high-power level control potentiometer R44 maximum counterclockwise and depress the HIGH VOLTAGE OFF push-button switch.

2-36. RF SECTION CHECK

- a. Adjust PA SCREEN PROTECTOR potentiometer maximum counter clockwise. Only the following PA MULTIMETER switch positions should indicate above zero at this time.
1. OSC POWER SUPPLY VOLTS 0-300 should indicate between 90 and 140 volts.
 2. DRIVER GRID AMPS 0.03 should indicate over half-scale on the meter. Peak the indication by varying the RF DRIVER GRID TUNE control.
- b. Depress the HIGH VOLTAGE ON pushbutton switch to energize all power supplies in the Isolated Enclosure. POWER AMPLIFIER SCREEN CURRENT should indicate less than 1.5 amperes. Adjust DRIVER PLATE TUNE control about 1/2-turn for maximum POWER AMPLIFIER SCREEN CURRENT indication.
- c. Set the POWER AMPLIFIER SCREEN CURRENT indication to approximately two amperes by adjusting the PA SCREEN PROTECTOR control potentiometer clockwise. The PA MULTIMETER should indicate approximately the following values:

POWER AMP SCREEN VOLTS 0-1200	650
PA GRID AMPS 0-1.2	.025
PWR AMPL BIAS VOLTS 0-1200	600
DRIVER PLATE VOLTS 0-3000	1300
DRIVER CATHODE AMPS 0-1.2	0.6
DRIVER SCREEN VOLTS 0-1200	420
DRIVER GRID AMPS 0.03	0
OSC POWER SUPPLY VOLTS 0-300	110

HUM NULL ADJ. 1A1A2R24 CMRR ADJ. 1A1A2R18 INPUT GAIN ADJ. 1A1A2R11 (BEHIND TRANSFORMER) MOD TRACKING ADJ. 1A1A2R26

BESSEL FILTER IN/OUT SWITCH 1A1A2S1 AUDIO BYPASS SWITCH 1A2A3S1 LOW POWER INPUT AUDIO ADJ. 1A1A2R2

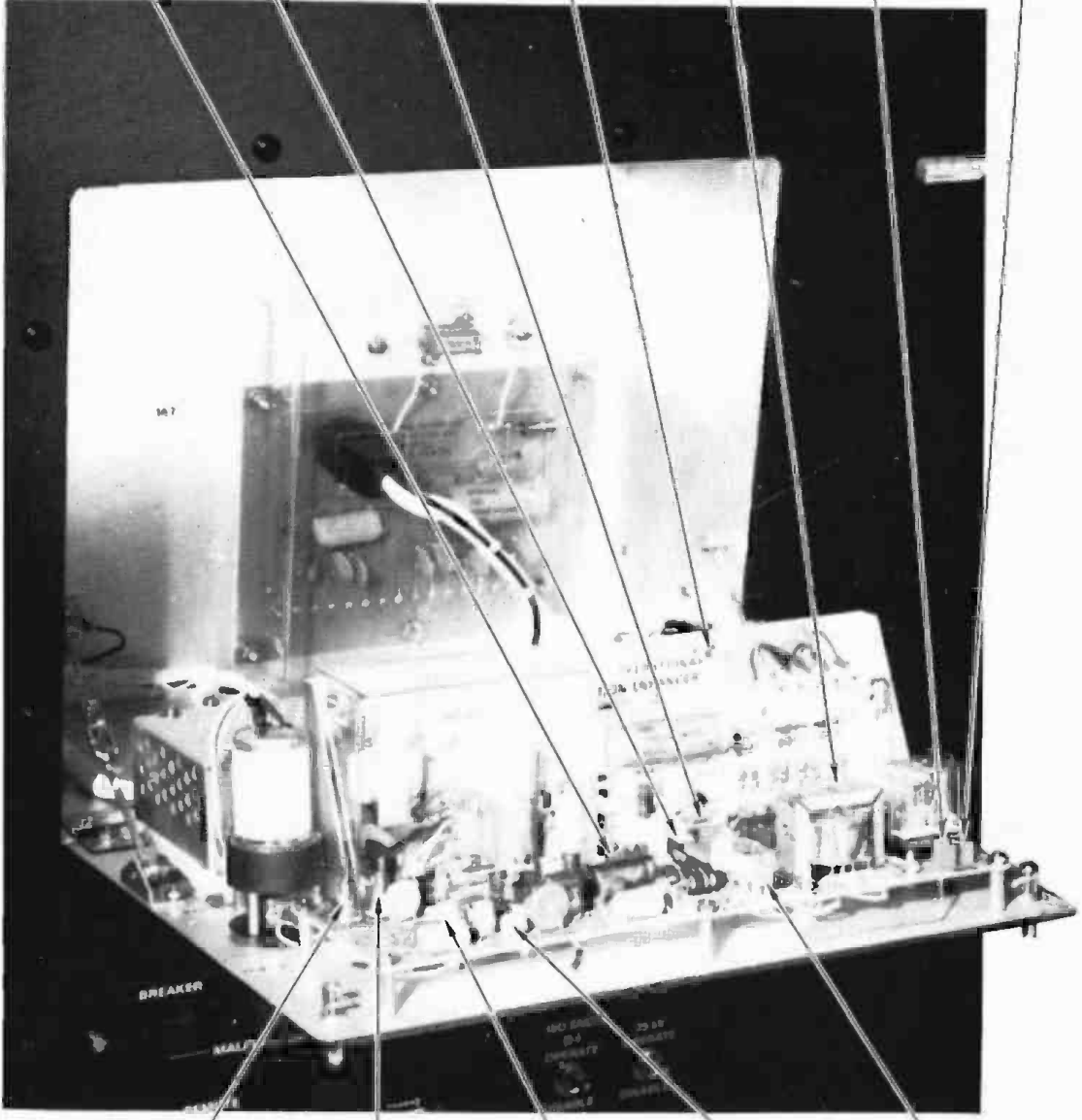

LOW POWER LEVEL ADJ. 1A1A2R45 HIGH POWER LEVEL ADJ. 1A1A2R44 DISS ADJ. 1A1A2R34 JACK 1A1A2J1 CARR SHIFT ADJ. 1A1A2R36

Figure 2-24. PDM Controls

- d. The Isolated Enclosure is now tuned for operation. Depress the HIGH VOLTAGE OFF and FILAMENT OFF pushbutton switches.

2-37. HIGH VOLTAGE CHECK

2-38. The transmitter will first be brought up to partial power. Ensure that the transmitter is terminated in a 50-ohm load. The High-Voltage Power Supply primary must be connected in a delta configuration for a 50kW supply or connected in a wye input configuration in case of a 100kW supply. The high-voltage lead must be connected to the CT terminal (half-voltage). The transmitter is now ready for application of high voltage. Fuses may be installed, if used, and the main 200-ampere disconnect closed.

- a. Depress the FILAMENT ON pushbutton switch/indicator. The switch/indicator should illuminate and the filaments should step-start ON in about five seconds.
- b. Depress the HIGH VOLTAGE ON pushbutton switch/indicator. The switch/indicator should illuminate, the high-voltage contactor should close, and supply volts should increase to approximately 12kV. The PA PLATE VOLTS meter should indicate zero volts after the high voltage has completely cycled on. If not, adjust the METER ZERO control, located at the left of the power control panel in the lower front section of Cabinet 1, to bring the meter pointer to zero. Refer to figure 3-2.
- c. Open the PDM chassis panel. Adjust dissipation control potentiometer R34 fully clockwise.
- d. Adjust high-power level control potentiometer R44 slowly counter-clockwise until the PA PLATE VOLTS meter indication rises to 5kV or the POWER AMPLIFIER PLATE CURRENT meter indication rises to 3 amperes, whichever occurs first.

CAUTION

ADJUSTMENTS OF THE PA PLATE TUNING SHOULD BE LIMITED TO 2 TURNS CW OR CCW FROM ORIGINAL SETTING. NO GREATER ADJUSTMENT SHOULD BE REQUIRED AS PA PLATE TUNING IS PRESET DURING FACTORY FINAL TEST.

- e. Mark the position of the PLATE TUNE control so that the original factory setting will not be lost. The control may be adjusted two turns CW or CCW to resonate the PLATE circuit while monitoring the POWER AMPLIFIER PLATE CURRENT meter for a dip.
- f. Adjust the LOADING control, if necessary, until high-power level potentiometer R44 can be adjusted up to 5kV PA PLATE VOLTS meter indication with a POWER AMPLIFIER PLATE CURRENT meter indication of 3 amperes.

- g. Increase power until the SUPPLY CURRENT meter indicates approximately 3.95 amperes. The POWER meter should indicate 40kW, the POWER AMPLIFIER PLATE CURRENT meter should indicate 5.4 amperes and the PA PLATE VOLTS meter should indicate 8.5kV.

CAUTION

ADJUSTMENTS OF THE GRID EFFICIENCY RESONATOR SHOULD BE LIMITED TO 1/2-TURN CW OR CCW FROM ORIGINAL SETTING. NO GREATER ADJUSTMENT SHOULD BE REQUIRED AS THE EFFICIENCY RESONATORS ARE PRESET DURING FACTORY FINAL TEST.

- h. Mark the position of the GRID EFFICIENCY RESONATOR control. The control may be adjusted 1/2-turn CW or CCW to resonate the PA grid circuit while monitoring PA PLATE VOLTS for a dip.
- i. Adjust high-power level potentiometer R44 more clockwise to increase the SUPPLY CURRENT meter indication to 5 amperes. If the dc does not trip, adjust DC HIGH VOLTAGE OVERLOAD control until the transmitter trips out at a SUPPLY CURRENT meter indication of 4.5 amperes. High voltage should now be off.
- j. Depress FILAMENT OFF pushbutton switch. After a blower run-down period of 5 minutes remove all ac inputs with primary disconnects.
- k. Use grounding sticks to short the high-voltage circuitry and capacitors to ground. Leave the sticks in the shorting positions.

WARNING

DISCONNECT AND LOCK OUT STATION PRIMARY POWER TO THE TRANSMITTER. USE A GROUNDING STICK TO DISSIPATE POTENTIAL FROM ALL TAPS AND COMPONENTS BEFORE TOUCHING THEM.

- l. Open the high-voltage supply protection barrier and short the positive full-voltage and half-voltage (CT) terminals to ground. Remove the high-voltage wire from the half-voltage (CT) and connect to the full-voltage terminal.
- m. Replace all grounding sticks on their interlocked holders and close all transmitter and power supply barrier doors.
- 2-39. POWER AND MODULATION CHECK
- 2-40. HIGH POWER ADJUSTMENT. To check the transmitter at its high-power level output, fully modulated, proceed as follows:

CAUTION

EFFICIENCY RESONATORS AND PLATE TUNING AFFECT POWER OUTPUT, EFFICIENCY AND DISTORTION. ADJUSTMENTS SHOULD BE LIMITED TO 1/2-TURN CW OR CCW DEVIATION FROM ORIGINAL SETTINGS. NO GREATER ADJUSTMENT SHOULD BE REQUIRED AS ALL HAVE BEEN PREALIGNED DURING FACTORY FINAL TEST.

- a. Adjust high-power level potentiometer R44 maximum counterclockwise, zero power output position.
- b. Depress FILAMENT ON pushbutton switch/indicator. The switch/indicator should illuminate.
- c. After filaments have step-started, depress HIGH VOLTAGE ON pushbutton switch/indicator. The switch/indicator should illuminate.
- d. Adjust high-power level potentiometer R44 clockwise until power output is 55kW. The PA PLATE VOLTS meter should indicate approximately 9.4kV and the POWER AMPLIFIER CURRENT meter should indicate approximately 6.2 amperes. If the above ratio of voltage to current is not present, adjust the LOADING control. This voltage-to-current ratio should be present but will vary from transmitter to transmitter. Values given are approximate. Check the Transmitter Test Specification Sheets for exact values.
- e. Operate the modulator MULTIMETER switch to AUX DRIVER AMPS 0-1.2. Note the optimum value for each individual transmitter on the test specification sheets. Adjust the AUXILIARY DRIVER control to obtain the current listed on the Factory Test Specification Sheets.
- f. Modulate the transmitter 95 percent negative with a 100 Hz tone. The POWER AMPLIFIER PLATE CURRENT METER and PA PLATE VOLTS meter indication may rise slightly. MODULATION ENHANCER bypass/operational switch 1A2S1 should be in the bypass position at this time (refer to figure 2-24).
- g. Adjust the PA SCREEN PROTECTOR control for a POWER AMPLIFIER SCREEN CURRENT meter indication of between 1.7 and 2.0 amperes. Note the optimum value for each individual transmitter on the Factory Test Specification Sheets.
- h. If necessary, adjust the AUXILIARY DRIVER control at 95 percent modulation with a 1000 Hz tone for equal positive and negative peaks. It should be near the center of its range.

- i. With modulation on, adjust dissipation limiter control potentiometer R34, on the PDM chassis, counterclockwise until a slight reduction in PA PLATE VOLTS meter or POWER meter indication is noted. Then adjust the control about 1/4-turn clockwise.
- j. Adjust carrier shift control potentiometer R36 (located on the PDM chassis) to minimize carrier shift to less than one percent.

2-41. LOW-POWER ADJUSTMENT. The following low-power adjustments must be accomplished after the high-power adjustments are completed. To adjust the transmitter to the selected low-power output, proceed as follows:

CAUTION

EFFICIENCY RESONATORS AND PLATE TUNING AFFECT POWER OUTPUT, EFFICIENCY AND DISTORTION. ADJUSTMENTS SHOULD BE LIMITED TO 1/2-TURN CW OR CCW DEVIATION FROM ORIGINAL SETTINGS. NO GREATER ADJUSTMENT SHOULD BE REQUIRED AS ALL HAVE BEEN PREALIGNED DURING FACTORY FINAL TEST.

- a. Adjust low-power level control potentiometer R45 on the PDM, chassis, maximum clockwise. Refer to figure 2-24.
- b. With the transmitter operating at high power, depress POWER LOW pushbutton switch. The power should drop very little.
- c. Adjust low-power level control potentiometer R45, on the PDM chassis, for the output power required (10kW or 25kW).
- d. Distortion is generally a bit greater at low power but is minimized by changing the value of resistor 1A1R3 in Cabinet 1 (refer to figure 2-25). Maximum resistance is used for 10kW output power. Move the resistor tap 1/2-inch at a time until distortion is minimized.
- e. Adjust low-power input audio control potentiometer R26, on the PDM chassis, to obtain the same percentage of modulation as obtained at the high-power level.
- f. Adjust the POWER ADJUST RAISE/LOWER control to the center of its range. Operate the transmitter for 20 minutes. Depress POWER HIGH pushbutton switch. Adjust high-power level adjust potentiometer R44 for the desired transmitter high-power level output. Depress POWER LOW pushbutton switch/indicator. Adjust low-power level adjust potentiometer R45 for the desired transmitter low-power level output. The POWER ADJUST RAISE/LOWER control will now be capable of making a +20 percent change in transmitter power output.

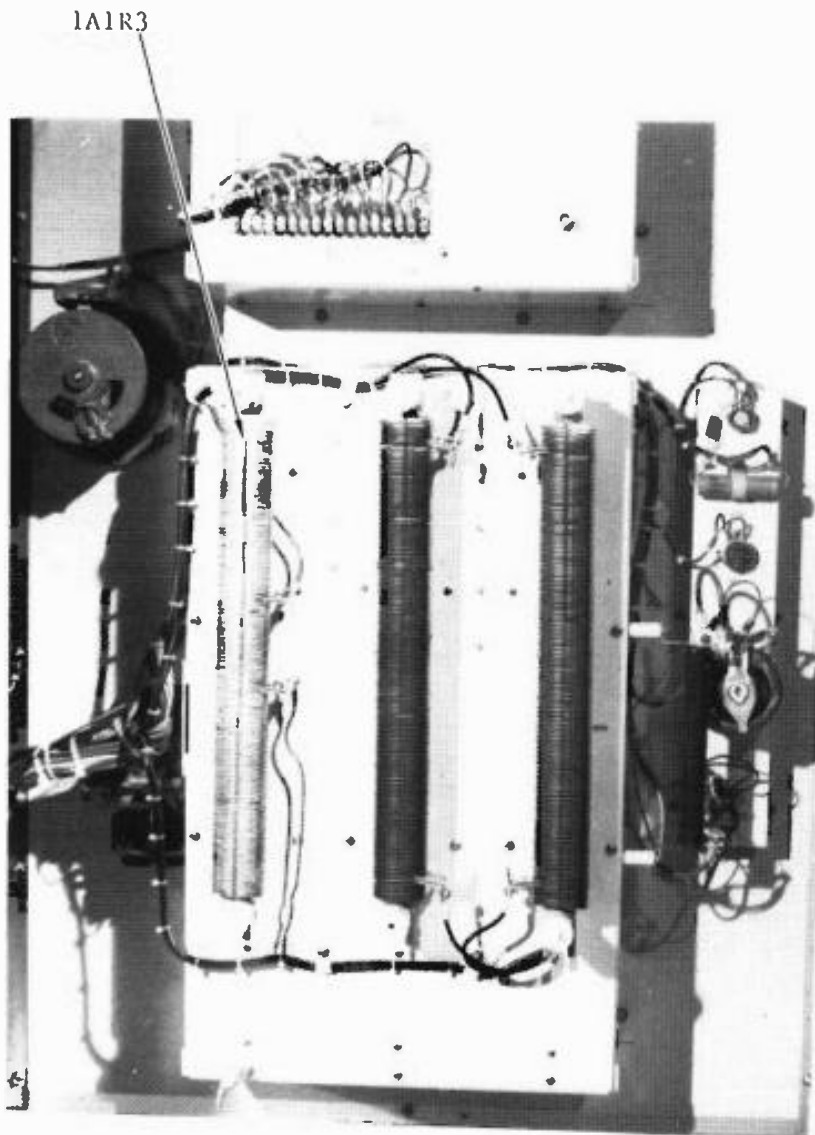

Figure 2-25. Low-Power Distortion Adjustment

WARNING: Disconnect primary power prior to servicing.

2-42. TYPICAL METER READINGS

2-43. Typical meter readings for various power levels are given in table 2-1. The values stated are approximate. For exact readings, refer to the Factory Final Test Specification Sheets furnished with the transmitter.

Table 2-1. Typical Meter Readings (100 Percent Modulation)

METER	10kW	25kW	50kW
SUPPLY VOLTS	24.9 kV	24.8 kV	24.5 kV
SUPPLY CURRENT	1.1 A	2.3 A	4.4 A
PA PLATE VOLTS	4.1 kV	6.5 kV	9.6 kV
PA PLATE CURRENT	3.1 A	4.5 A	6.7 A
PA SCREEN CURRENT	2 A	2 A	2 A
PA FILAMENT VOLTS	9.8 V	9.8 V	9.8 V
MOD FILAMENT VOLTS	9.8 V	9.8 V	9.8 V

Modulator MULTIMETER:

DRIVER SOURCE AMPS 0-3	1.05 A	0.9 A	0.75 A
DRIVER GATE VOLTS 0-30	8.5 V	7.0 V	5.5 V
DRIVER DRAIN VOLTS 0-1200	100 V	150 V	200 V
MOD GRID VOLTS 0-1200	400 V	390 V	250 V
MOD SCREEN VOLTS 0-1200	585V	620V	595V
MOD SCREEN AMPS 0-3	1.45 A	1.65 A	2.1 A
AUX DRIVER AMPS 0-1.2	0.02 A	0.02 A	0.08 A
AUX DRIVER VOLTS 0-120	95 V	95 V	95 V

PA MULTIMETER:

POWER AMPL SCREEN VOLTS 0-1200	620 V	635 V	640 V
PA GRID AMPS 0-1.2	0.18A	0.2 A	0.22 A
PWR AMPL BIAS VOLTS 0-1200	580 V	580 V	580 V
DRIVER PLATE VOLTS 0-3000	1300 V	1350 V	1380 V
DRIVER CATHODE AMPS 0-1.2	0.56 A	0.61 A	0.61 A
DRIVER SCREEN VOLTS 0-1200	400 V	420 V	420 V
DRIVER GRID AMPS 0.03	0 A	0 A	0 A
OSC POWER SUPPLY VOLTS 0-300	110 V	110 V	110 V

2-44. If high-power level-control potentiometer R44 is set for 50kW operation and high voltage removed, readings of the modulator sections will not agree with those listed since negative feedback from the plate circuit will not be present. This will turn the PDM full on to 100 percent pulse width. To view the pulses on an oscilloscope, high-power level control potentiometer R44 must be adjusted counterclockwise to lower the duty cycle to an observable value.

2-45. If high voltage is turned off, only the oscillator power supply and driver grid will indicate on the PA MULTIMETER. With filaments ON and no high voltage, DRIVER GRID AMPS should indicate from two-thirds to a full-scale reading, indicating the presence of rf drive. This provides a good check of oscillator output and tuning.

2-46. If the test specification sheets are reviewed closely, an increase in dc plate voltage and dc plate current will be noted even under conditions of zero carrier shift. A 200 to 300-volt rise is normal. This is due to a dynamic change in the action of the 3rd Harmonic Resonator. An increase of more than 300 volts may be an indication of mistuning of the efficiency resonators, insufficient PA screen current or improper loading. Before any adjustments are made, review the theory section of this manual carefully.

SECTION III

OPERATION

3-1. INTRODUCTION

3-2. This section contains information pertaining to the operation of the HARRIS MW-50C3 MEDIUM WAVE AM BROADCAST TRANSMITTER as well as the identification, location, and function of the controls and indicators.

3-3. CONTROLS AND INDICATORS

3-4. Tables 3-1 through 3-8 list Controls and Indicators with the function of each. Figures 3-1 through 3-8 show the location of each control and indicator.

3-5. OPERATION

3-6. TRANSMITTER TURN ON

3-7. The operation procedure is presented under the assumption that the transmitter has been thoroughly and properly aligned and is free of any discrepancies. Visually inspect the transmitter to ensure that no foreign objects are inside the cabinet, all parts and components are properly installed, all connectors are secure, all grounding sticks are on their respective hooks and all doors are closed. To turn the transmitter on, proceed as follows:

- a. During normal operation, the FILAMENT ON pushbutton switch/indicator is depressed. If the transmitter is remotely controlled, a contact is made by the remote control system to turn on the transmitter tube filaments. This contact is maintained in remote operation as a failsafe requirement. The AIR MALFUNCTION indicator will illuminate momentarily and extinguish as air flow from the blower and fan increases.
- b. After an approximately five-second delay for filament step-start operation, HIGH VOLTAGE ON pushbutton switch/indicator may be depressed. If the transmitter is remotely controlled, a momentary contact is made across the high-voltage ON terminals. The transmitter will now be on the air.

CAUTION

IF POWER IS TO BE REDUCED AT THE SAME TIME THAT THE STATION GOES DIRECTIONAL, BOTH HIGH/LOW POWER AND CARRIER OFF FUNCTIONS MUST BE CARRIED OUT SIMULTANEOUSLY. TRANSMITTER CARRIER IS NOT CUT DURING A HIGH/LOW POWER CHANGE.

- c. AUTO ON pushbutton switch/indicator may be depressed or operated remotely. This provides for automatic transmitter return to operation after power failure.

3-8. TRANSMITTER SHUTDOWN

CAUTION

IT IS NOT RECOMMENDED THAT THE TRANSMITTER BE SHUT DOWN BY TURNING THE FILAMENTS OFF WITHOUT FIRST TURNING OFF HIGH VOLTAGE. WHEN THE HIGH-VOLTAGE SHORTING SWITCHES CLOSE, THE HIGH-VOLTAGE POWER SUPPLY WILL DISCHARGE, PLACING MANY COMPONENTS UNDER UNDUE STRESS.

WARNING

IF THE TRANSMITTER IS EVER TURNED OFF BY DEENERGIZING THE FILAMENTS AND THE AUTOMATIC RETURN TO AIR FUNCTION IS ENERGIZED AT TURN OFF, THE TRANSMITTER WILL CYCLE ON BY ITSELF WHEN THE FILAMENTS ARE AGAIN TURNED ON AS IF EXPERIENCING POWER FAILURE.

- 3-9. To turn the transmitter OFF, depress the HIGH VOLTAGE OFF pushbutton switch. This removes the automatic transmitter return to operation function, removes high voltage, and discharges the high-voltage capacitors. The FILAMENT OFF pushbutton switch should then be depressed.

3-10. MODULATION ENHANCEMENT

SPECIAL NOTICE

OPERATIONAL/BYPASS SWITCH POSITION SHOULD NEVER BE CHANGED WHILE A PROGRAM IS ON THE AIR. THIS SWITCH IS USED TO PUT THE MODULATION ENHANCER ON OR OFF LINE AND CAUSES A 6 dB CHANGE IN MODULATION (OVERMODULATION IF SWITCHED TO BYPASS, UNDERMODULATION IF SWITCHED TO OPERATIONAL). THE OPERATOR MUST CHANGE THE MODULATION OF THE TRANSMITTER ACCORDING TO THE SETTING OF THE SWITCH. ADDS 6 dB WHEN SWITCHED TO THE OPERATIONAL POSITION. REMOVES 6 dB WHEN SWITCHED TO BYPASS POSITION.

3-11. If modulation enhancement is desired, set the OPERATIONAL/BYPASS switch to OPERATIONAL. Adjust the Modulation Enhancer as follows:

- a. Depress the CAL OUT pushbutton switch.
- b. Modulate the transmitter with typical music. Set the AGC and limiter for fastest operation. Set the limiter for 125 percent modulation.

NOTE

The desired amount of enhancing can only be determined by listening to the output. The more enhancing (3 dB maximum) the louder the signal.

- c. Depress the ENHANCING 1 dB, 2 dB, or 3 dB pushbutton switch and adjust NEG PEAK potentiometer R16 and POS PEAK potentiometer R20 for maximum negative and positive peaks without overmodulating.

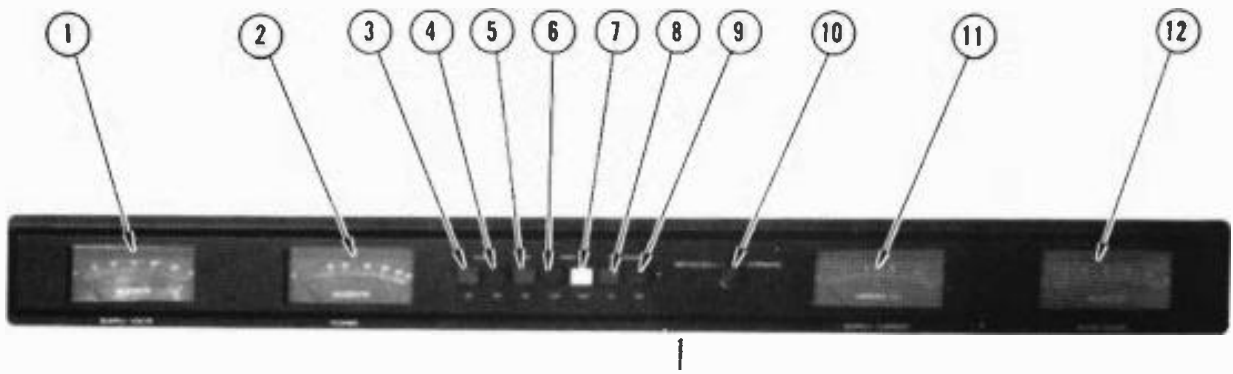

Figure 3-1. Meter Panel Controls and Indicators

Table 3-1. Meter Panel Controls and Indicators

REF.	CONTROL/INDICATOR	FUNCTION
1	SUPPLY VOLTS Meter	Indicates high-voltage dc supply voltage.
2	POWER Meter	Displays forward or reflected power as selected by REFLECTED/FORWARD switch.
3	FILAMENT ON Pushbutton Switch/ Indicator	Turns on filament. Indicates filament voltage is applied.
4	FILAMENT OFF Pushbutton Switch/ Indicator	Switch removes filament voltage from transmitter tubes. Indicator illuminates if a circuit breaker or temperature interlock opens.
5	AUTO ON Pushbutton Switch/ Indicator	Energized and indicates the automatic return to air after power failure feature is enabled.
6	POWER LOW Pushbutton Switch/ Indicator	Switch controls transistion to predetermined low-power level. Indicator shows low-power level has been selected.
7	POWER HIGH Switch/Indicator Indicator	Switch controls transistion to high-power level. Indicator shows high-power level has been selected.
8	HIGH VOLTAGE ON Pushbutton Switch/ Indicator	Switch controls application of high-voltage. Indicator shows high-voltage has been energized.
9	HIGH VOLTAGE OFF Pushbutton Switch/ Indicator	Switch removed high voltage from transmitter. Indicator illuminates if an interlock is violated.
10	REFLECTED/FORWARD Selector Switch	Selects between forward or reflected power as displayed on POWER meter.
11	SUPPLY CURRENT Meter	Indicates total transmitter current drain on high-voltage supply.
12	PLATE VOLTS Meter	Indicates dc PA plate potential.

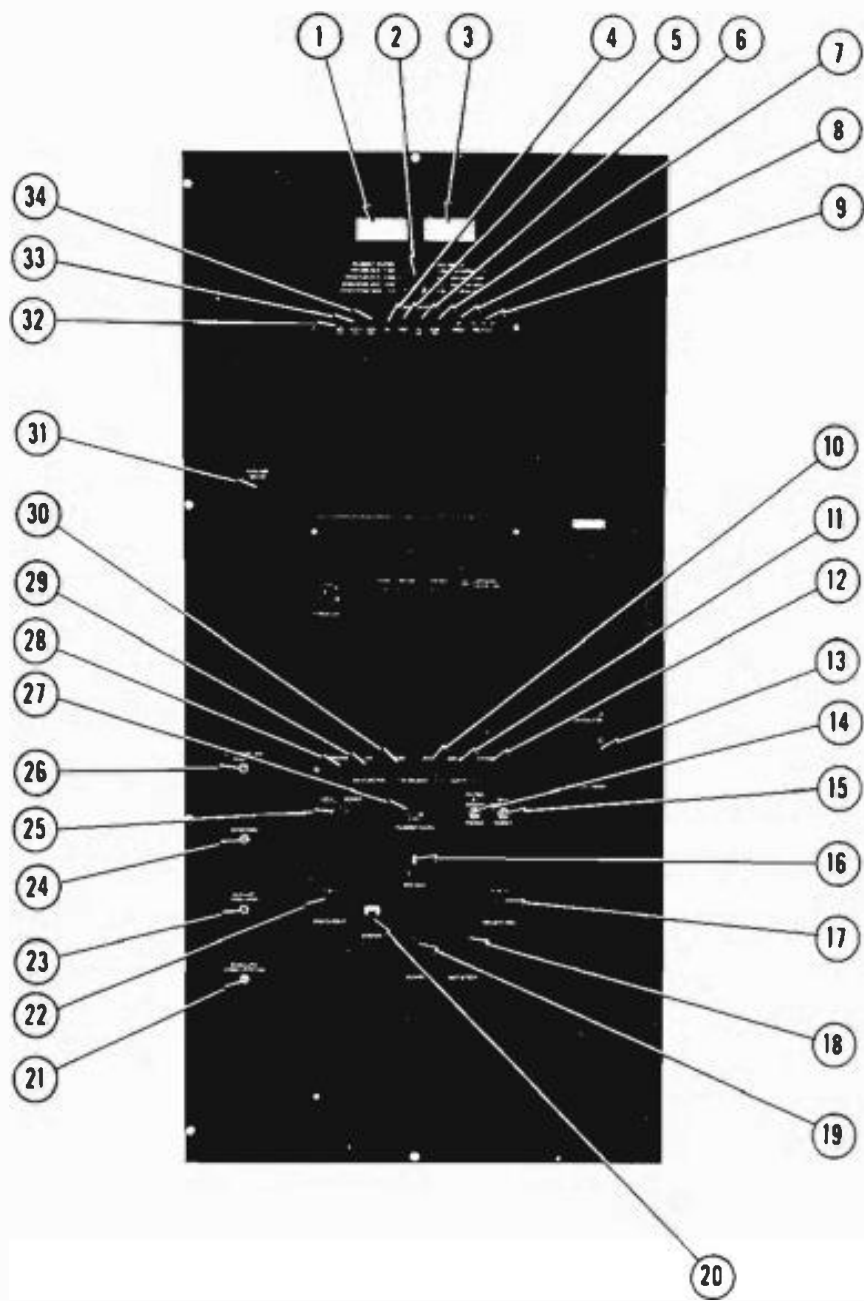

Figure 3-2. Cabinet 1 Left Side Controls and Indicators
(Sheet 1 of 2)

WARNING: Disconnect primary power prior to servicing.

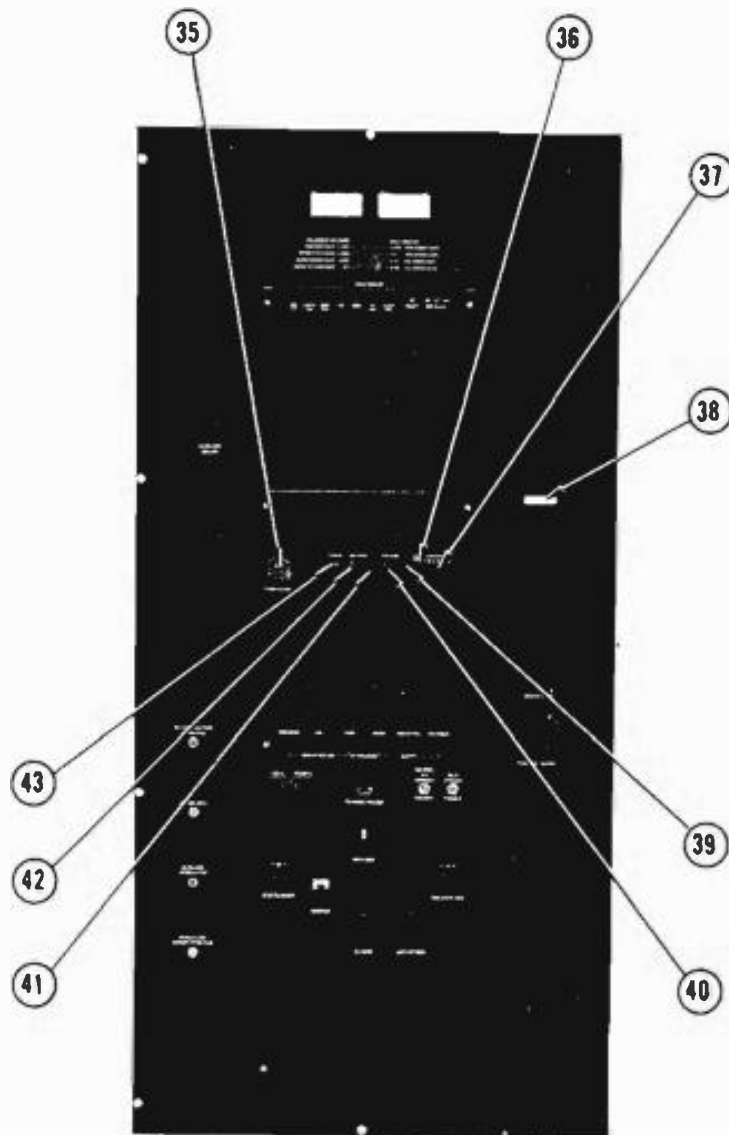

Figure 3-2. Cabinet 1 Left Side Controls and Indicators
(Sheet 2 of 2)

Table 3-2. Cabinet 1 Left Side Controls and Indicators

REF.	CONTROL/INDICATOR	FUNCTION
1	FILAMENT VOLTAGE Meter	Indicates modulator cabinet filament voltage.
2	MODULATOR MULTIMETER Selector Switch	Selects desired point to monitor modulator section voltage or current.
3	MODULATOR MULTIMETER Meter	Displays voltage or current selected by MODULATOR MULTIMETER switch.
4	DC WARNING LED	Illuminates when the total transmitter high-voltage supply current exceeds a predetermined level.
5	VSWR WARNING LED	Illuminates when voltage standing wave ratio exceeds a predetermined safe limit.
6	PA ARC WARNING LED	Indicates if an arc occurs from the PA plate to screen.
7	PLATE RES LED	Illuminates to indicate arcing across the gap in the 3rd harmonic PA plate efficiency resonator.
8	WARNING LED RESET Pushbutton Switch/ Indicator	Resets all fault indicators.
9	RECYCLE ON/OFF Switch	When ON, allows transmitter to recycle back to operation after a fault is detected and has cleared. When set to OFF, transmitter will not automatically recycle back to operation after detecting a fault.
10	DOOR SAFETY Indicator	Indicates door interlock is open.
11	GND STICK SAFETY Indicator	Indicates a ground stick has been removed from its designated hook.
12	EXTERNAL SAFETY Indicator	Indicates external safety interlock is OPEN.

Table 3-2. Cabinet 1 Left Side Controls and Indicators (Continued)

REF.	CONTROL/INDICATOR	FUNCTION
13	MODULATOR FILAMENT ADJUST	Adjusts modulator cabinet filament voltage.
14	25 kV OPERATE/DISABLE Switch	Controls primary power to high-voltage primary.
15	ISO ENCL B+ OPERATE/ DISABLE Switch	Controls primary power to Isolated Enclosure dc supplies and high-voltage controls.
16	MOD BIAS Circuit breaker	Controls primary power and provides overload protection for modulator bias power supply.
17	ISOLATED ENCL Circuit breaker	Controls primary power and provides overload protection for Isolated Enclosure ac circuits and power supplies.
18	MOD SCREEN Circuit breaker	Controls primary power and provides overload protection for the modulator screen and driver power supply.
19	BLOWER Circuit breaker	Controls primary power and provides overload protection for blower and fan.
20	CONTROL Circuit breaker	Controls primary power and provides overload protection for transmitter control circuits.
21	MODULATOR SCREEN OVERLOAD Control	Sets threshold of operation for modulator screen overload sensor.
22	MOD FILAMENT Circuit breaker	Controls primary power and provides overload protection for modulator filament circuit.
23	AUXILIARY MODULATOR Control	Assists 100% negative modulation.
24	METER ZERO Control	Adjusts PLATE VOLTS meter to zero.

Table 3-2. Cabinet 1 Left Side Controls and Indicators (Continued)

REF.	CONTROL/INDICATOR	FUNCTION
25	LOCAL/REMOTE Switch	Allows front panel or remote control of transmitter.
26	DC HIGH VOLTAGE OVERLOAD Control	Sets threshold of operation for dc high-voltage overload sensor.
27	FILAMENT HOURS Meter	Indicates hours of filament operation.
28	BREAKER MALFUNCTION Indicator	Indicates an open transmitter or modulator circuit breaker.
29	AIR MALFUNCTION Indicator	Indicates cooling air flow malfunction.
30	TEMP MALFUNCTION Indicator	Indicates over temperature condition.
31	AUXILIARY DRIVER Control	Equalizes symmetry of modulation by adjusting positive peaks.
32	ARC GAP Indicator	Illuminates when an arc occurs in ball gaps 1E1, 1E2, or 1E3.
33	OUTPUT ARC Indicator	Illuminates if an arc occurs between the PA output network and ground.
34	MOD SG Indicator	Indicates if modulator screen grid current exceeds a predetermined level.
35	POWER ADJUST Control	Adjusts transmitter output power over a range of about 20 percent.
36	CAL OUT Switch	Audio signal is routed directly to the transmitter without clipping to permit adjustment of the modulation prior to enhancement.
37	ENHANCING 1 dB/ 2 dB / 3 dB	Audio signal is applied to clipping transistors arranged to clip at 1 dB, 2 dB, or 3 dB.

Table 3-2. Cabinet 1 Left Side Controls and Indicators (Continued)

REF.	CONTROL/INDICATOR	FUNCTION
38	AIR PRESSURE Meter	Indicates air pressure in inches of water.
39	POS PEAK Adjustment	Used to adjust clipping threshold for positive audio peaks.
40	POS PEAK LED	Illuminates to indicate that the audio input has gone sufficiently positive to cause clipping by the Modulation Enhancer.
41	NEG PEAK Adjustment	Used to adjust clipping threshold for negative audio peak.
42	NEG PEAK LED	Illuminates to indicate that the audio input has gone sufficiently negative to cause clipping by the Modulation Enhancer.
43	POWER LED	Illuminates to indicate primary power is applied and the internal +12V power supply in the Modulation Enhancer is functioning properly.

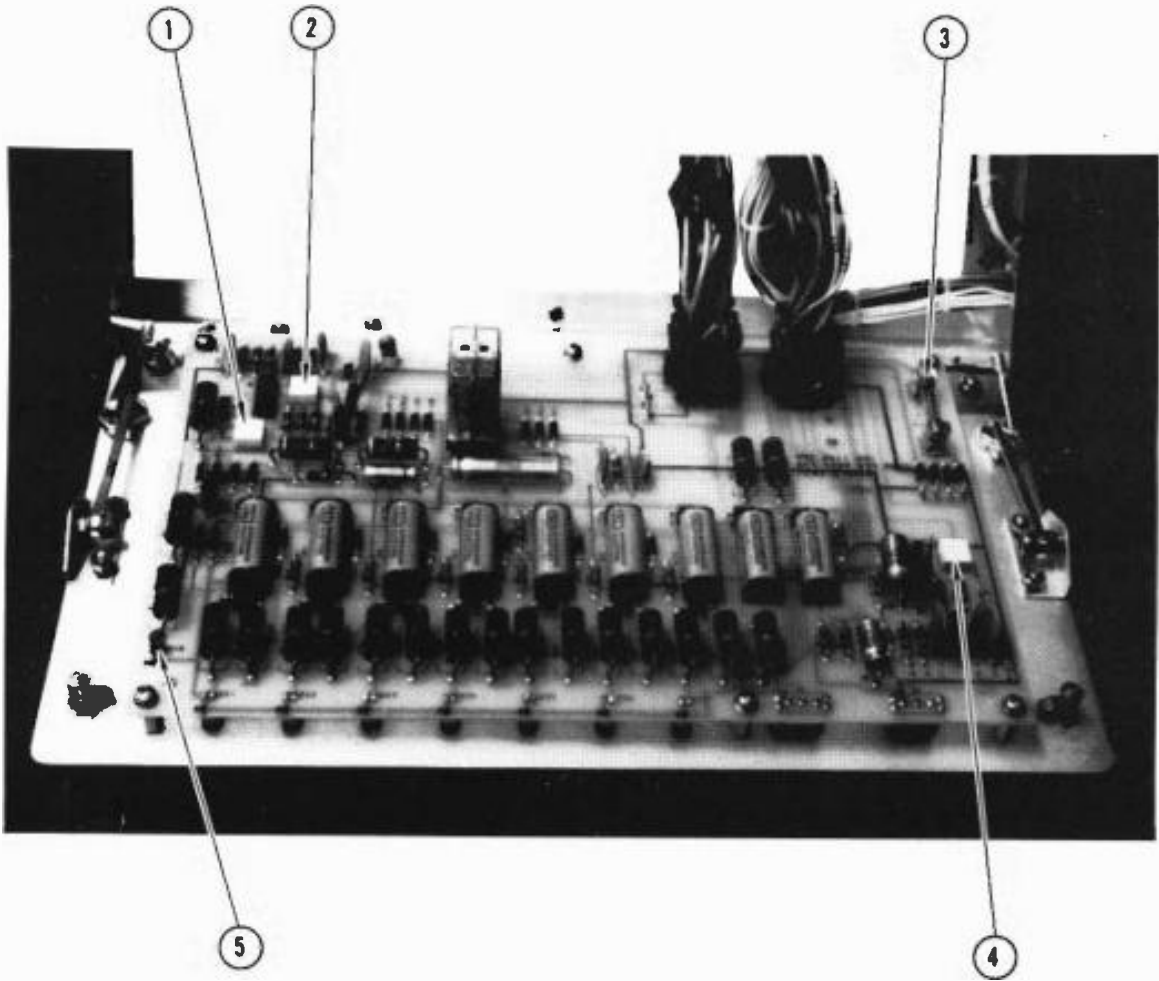

Figure 3-3. Cabinet 1 Fault and Overload Assembly
Printed-Circuit Board Controls and Indicators

Table 3-3. Cabinet 1 Fault and Overload Assembly
Printed-Circuit Board Controls and Indicators

REF.	CONTROL/INDICATOR	FUNCTION
1	Remote Plate Fine Adjust Potentiometer R31	Fine adjustment for remote plate voltage meter.
2	Remote Plate Coarse Adjust Potentiometer R21	Coarse adjustment for remote plate voltage meter.
3	Fuse F1	Protects 30-volt power supply.
4	Plate Resonator Overload Arc Sensor Adjust Potentiometer R72	Adjusts plate resonator arc overload sensor threshold of operation.
5	DC Voltage Fuse LED DS8	Indicates that DC Voltage fuse is not open and that +30 volts is present.

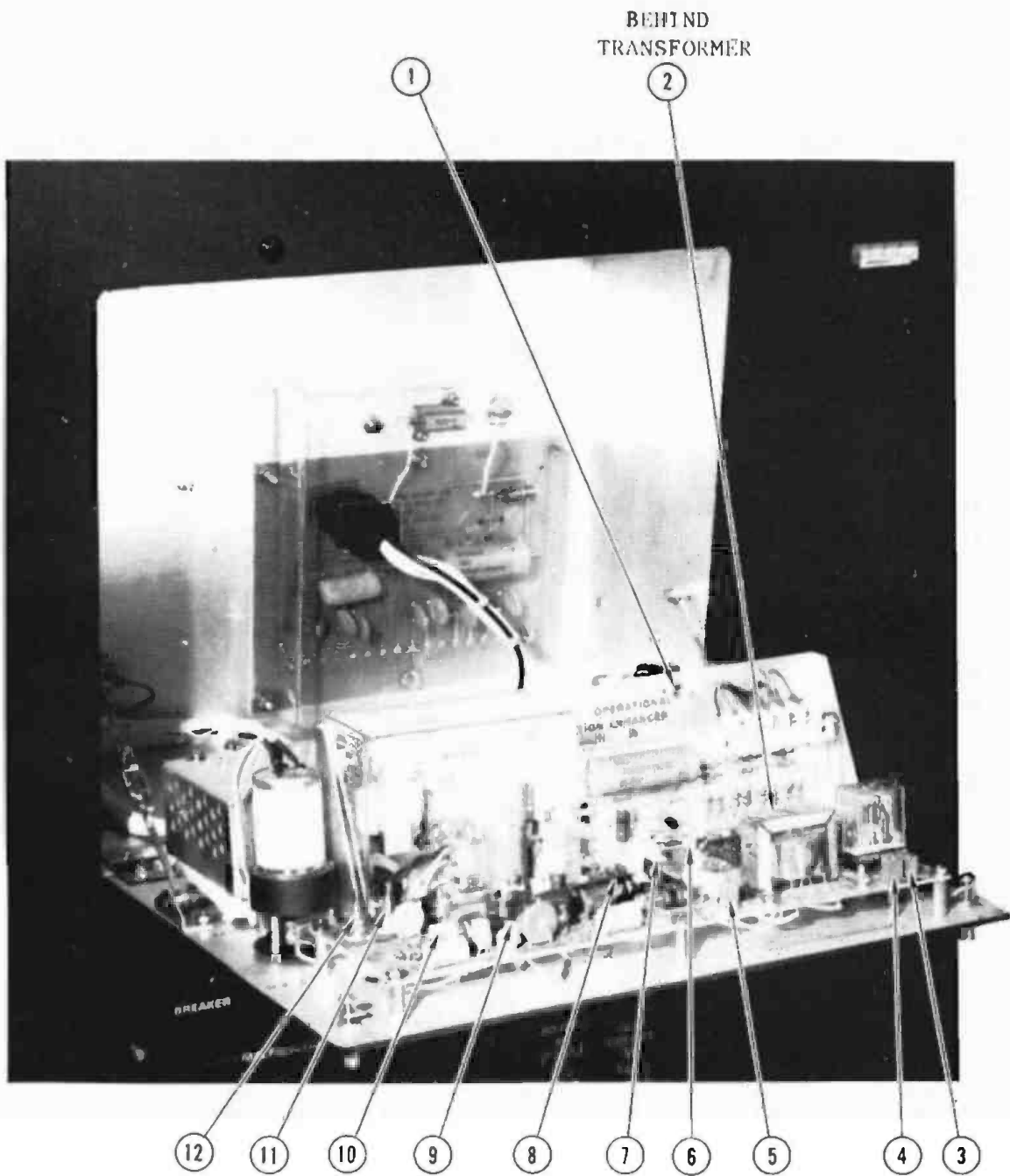

Figure 3-4. Cabinet 1 PDM Controls and Indicators

Table 3-4. Cabinet 1 PDM Controls and Indicators

REF.	CONTROL/INDICATOR	FUNCTION
1	AUDIO BYPASS Switch 1A2A3S1	Permits audio to be processed by the Modulation Enhancer when set to <u>operational</u> . When set to BYPASS, routes to <u>bypass</u> Modulation Enhancer.
2	INPUT GAIN Potentiometer 1A1A2R11	Provides adjustment for 100% modulation audio input level from 0 dBm to +10 dBm.
3	MODULATION TRACKING Potentiometer 1A1A2R26	Adjusts modulation tracking circuitry for best linearity.
4	LO POWER AUDIO Potentiometer 1A1A2R25	Adjusts to provide low-power audio input at same level as high-power audio input.
5	JACK Jumper 1A1A2J1	Jumper position adjusts hum phase. To be positioned for greatest signal-to-noise ratio.
6	CMRR Potentiometer 1A1A2R18	Adjusts input amplifier common mode rejection ratio at low frequencies.
7	BESSEL FILTER IN/OUT Switch 1A1A2S1	Allows besseL low-pass filter to be inserted in audio input circuitry for overshoot reduction and anti-aliasing protection.
8	HUM NULL Potentiometer 1A1A2R24	Adjusts hum injection level. To be adjusted for greatest signal-to-noise ratio.
9	CARRIER SHIFT Potentiometer 1A1A2R36	Adjusts to provide minor feedback corrections for shift of carrier during modulation.
10	DISS LIMITER Potentiometer 1A1A2R34	Adjusts to set reference point at which overload occurs due to change between input power and output power.

Table 3-4. Cabinet 1 PDM Controls and Indicators (Continued)

REF.	CONTROL/INDICATOR	FUNCTION
11	HI PWR Potentiometer 1A1A2R44	Adjusts rf carrier output from 0 to 60,000 watts when operating in the high-power mode.
12	LO PWR Potentiometer 1A1A2R45	Adjusts rf carrier output from 0 to 50,000 watts when operating in the low-power mode.

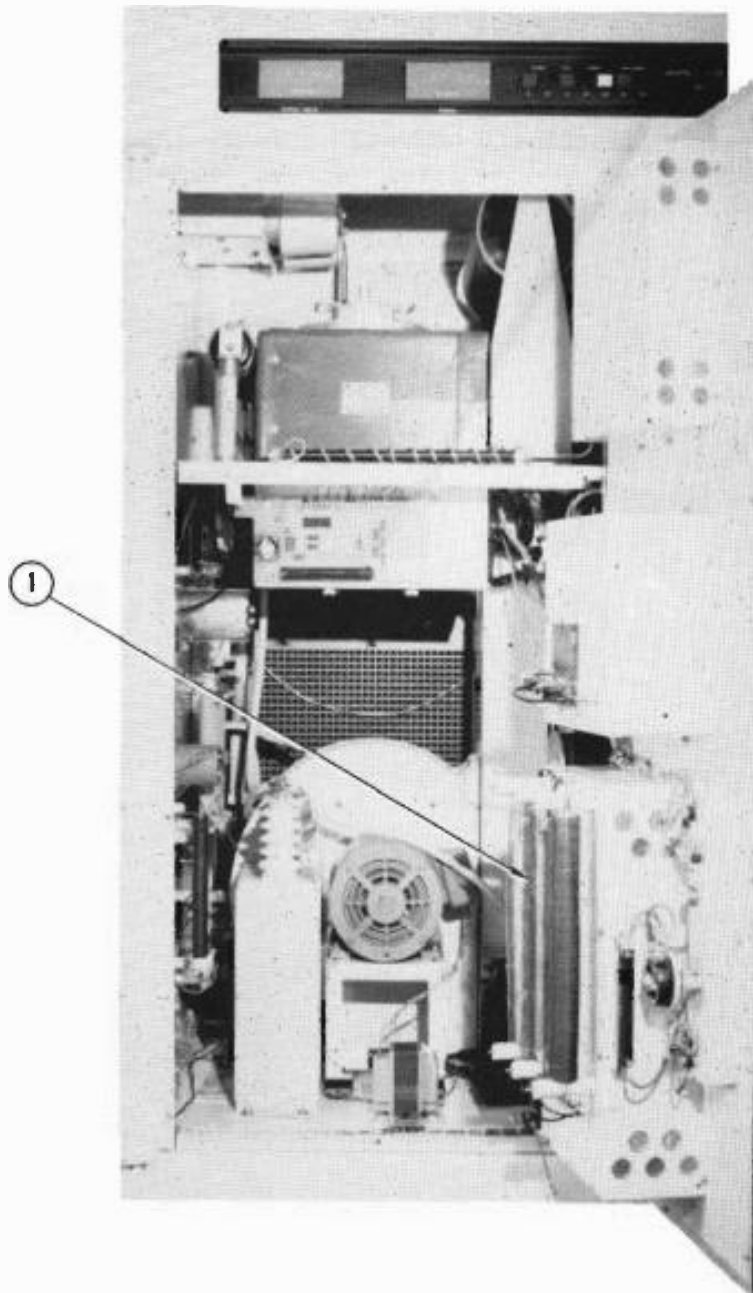

Figure 3-5. Cabinet 1 Internal Controls and Indicators

888-2213-001

3-17

WARNING: Disconnect primary power prior to servicing.

www.americanradiohistory.com

Table 3-5. Cabinet 1 Internal Controls and Indicators

REF.	CONTROL/INDICATOR	FUNCTION
1	Low Power Distortion Adjustment Resistor 1A1R3	Adjusts primary input voltage to modulator screen and driver power supply to minimize low-power level distortion.

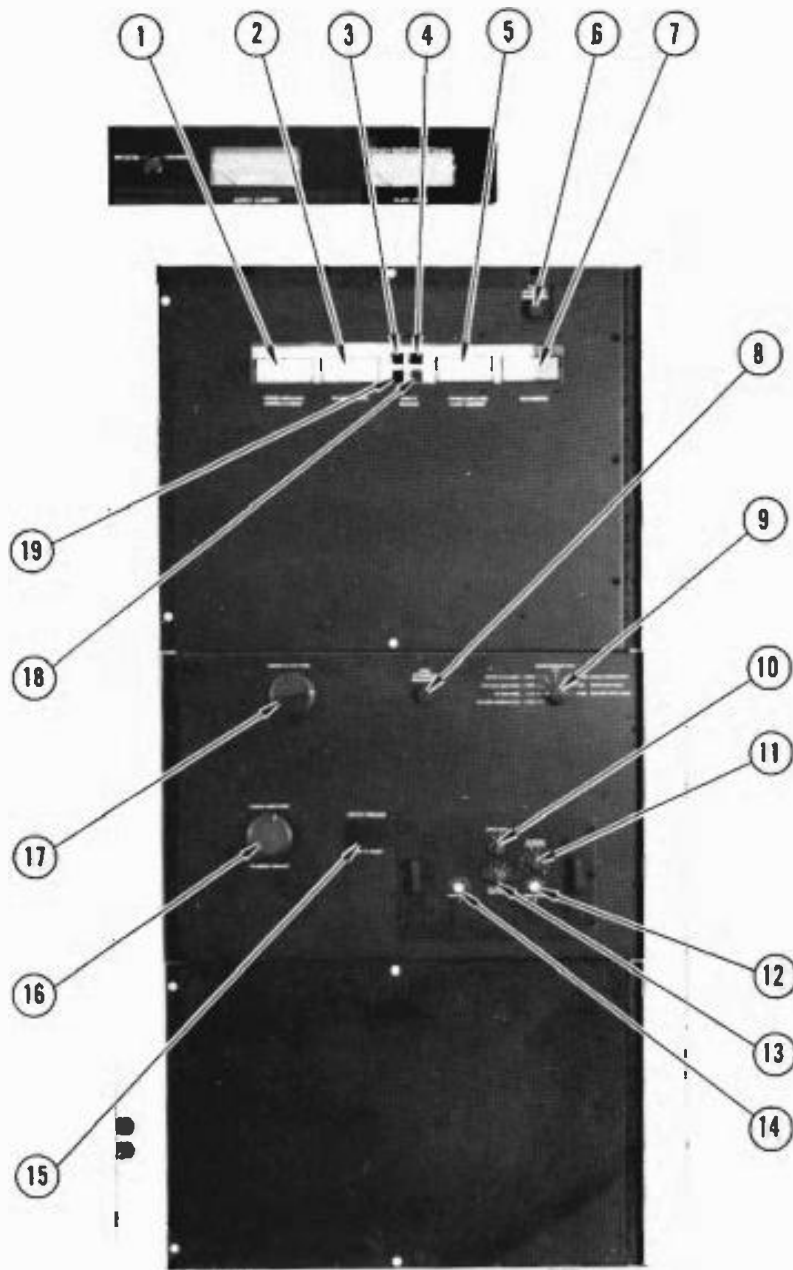

Figure 3-6. Cabinet 1 Right Side Controls and Indicators

Table 3-6. Cabinet 1 Right Side Controls and Indicators

REF.	CONTROL/INDICATOR	FUNCTION
1	POWER AMPLIFIER SCREEN CURRENT Meter	Indicates PA Amplifier screen grid current.
2	PA FILAMENT VOLTS Meter	Indicates PA Filament voltage.
3	BIAS CIRCUIT BREAKER Indicator	Indicates if RF Driver and PA control grid bias supply circuit breaker in Isolated Enclosure opens.
4	SCREEN CIRCUIT BREAKER Indicator	Indicates if screen current circuit breaker in Isolated Enclosure opens.
5	POWER AMPLIFIER PLATE CURRENT Meter	Indicates PA amplifier plate current.
6	PLATE EFFICIENCY RESONATOR Control	Tunes PA for maximum stage efficiency.
7	PA MULTIMETER Meter	Displays voltage or current as selected by PA MULTIMETER switch.
8	GRID EFFICIENCY RESONATOR Control	Tunes PA grid circuit for maximum efficiency.
9	PA MULTIMETER Selector Switch	Selects desired point to monitor PA section voltage or current.
10	OSCILLATOR 1/2 Switch	Selects output from oscillator one or two.
11	PA SCREEN PROTECTOR Control	Sets threshold of PA screen protector circuit.
12	FREQ ADJUST 2 Control	Adjusts oscillator 2 frequency.

Table 3-6. Cabinet 1 Right Side Controls and Indicators (Continued)

REF.	CONTROL/INDICATOR	FUNCTION
13	RF DRIVER GRID TUNE Control	Adjusts tuning of RF Driver grid circuit.
14	FREQ ADJUST 1 Control	Adjusts oscillator 1 frequency.
15	CIRCUIT BREAKER PUSH TO RESET Lever	Resets all breakers within the Isolated Enclosure.
16	POWER AMPLIFIER FILAMENT ADJUST Control	Adjusts PA Amplifier Cabinet filament voltage.
17	DRIVER PLATE TUNE Control	Adjusts tuning of RF Driver plate circuit (1A9L1).
18	OSC CIRCUIT BREAKER Indicator	Indicates if oscillator circuit breaker Isolated Enclosure opens.
19	DRV FIL CIRCUIT BREAKER Indicator	Indicates if RF Driver filament circuit breaker in Isolated enclosure opens.

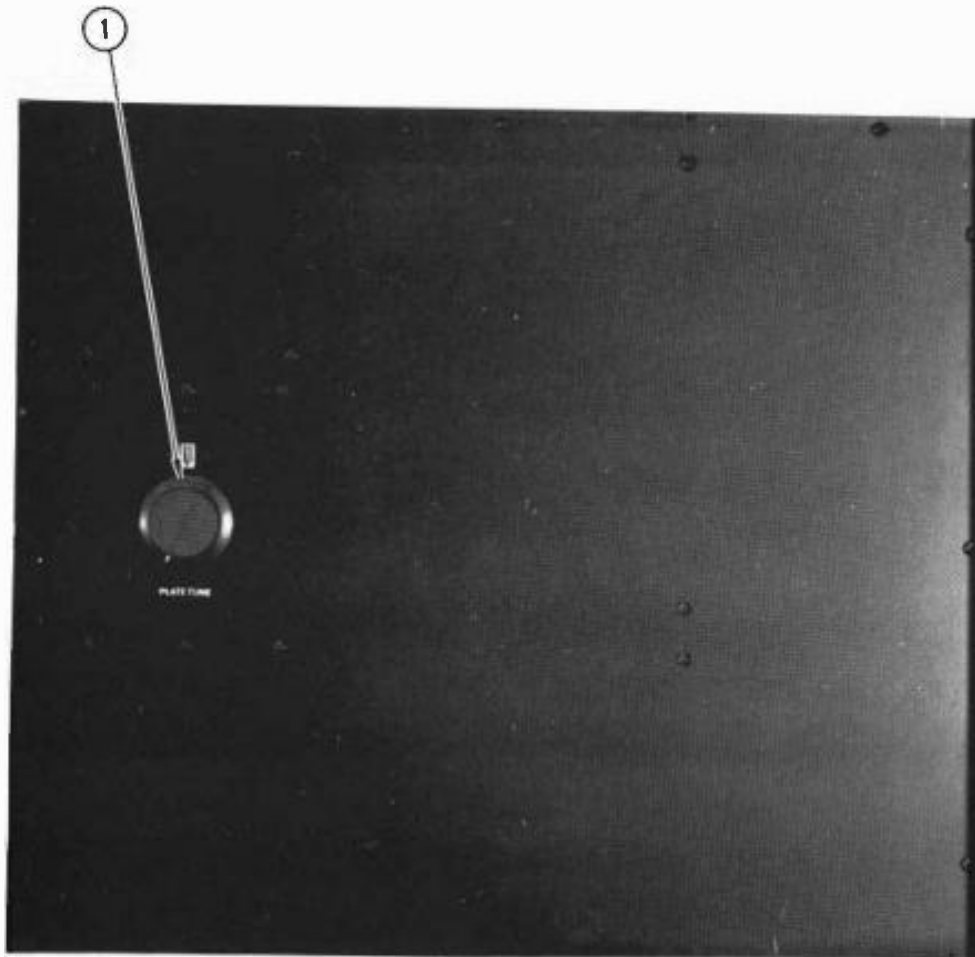

Figure 3-7. Cabinet 2 Left Side Controls and Indicators

Table 3-7. Cabinet 2 Left Side Controls and Indicators

REF.	CONTROL/INDICATOR	FUNCTION
1	PLATE TUNE Control	Adjusts tuning of PA plate circuit.

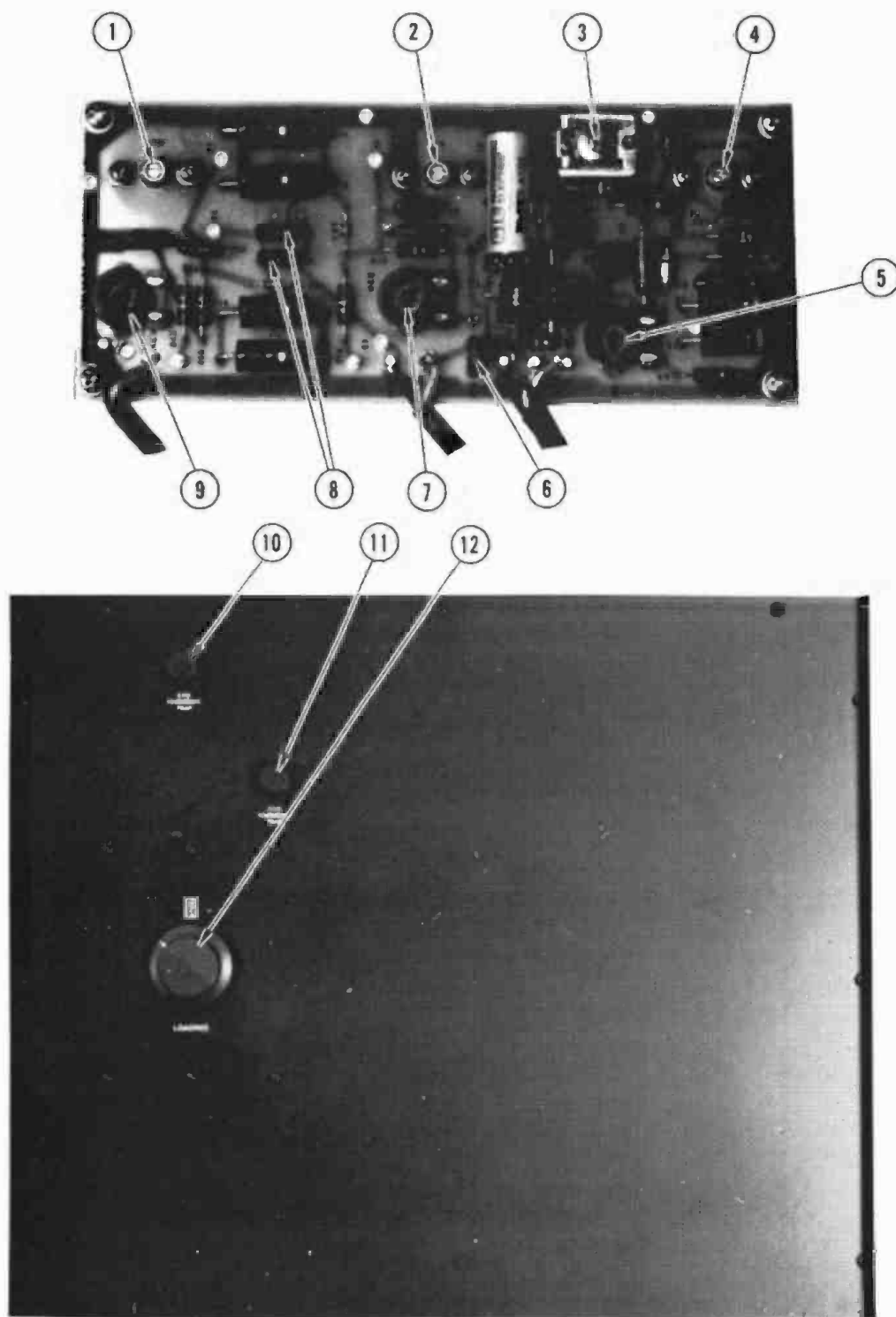

Figure 3-8. Cabinet 2 Right Side Controls and Indicators

Table 3-8. Cabinet 2 Right Side Controls and Indicators

REF.	CONTROL/INDICATOR	FUNCTION
1	Forward Power Null Adjustment	Balances forward port of the Directional Coupler.
2	Reflected Power Null Adjustment	Balances reflected port of the Directional Coupler.
3	VSWR Phase Adjustment (2)	Balances the phase difference between the VSWR voltage and current sensors.
4	VSWR Null Adjustment	Nulls the reflected power from the VSWR indication.
5	VSWR Trip Sensitivity Adjustment	Adjusts the threshold of the VSWR trip circuit.
6	Test Connector TJ3	Allows monitoring the reflected power indication, top position, or the VSWR sensor output, bottom position, with the POWER meter.
7	Reflected Power Meter Calibrate	Calibrates POWER meter to display reflected power.
8	Test Connectors TJ1 and TJ2	Allows calibration of the directional coupler forward power indication (horizontal position) and the reflected power indication (vertical position).
9	Forward Power Meter Calibrate	Calibrates POWER meter to display forward power.
10	3RD HARMONIC TRAP Adjustment	Reduces radiated power of 3rd Harmonic Trap.
11	2ND HARMONIC TRAP Adjustment	Reduces radiated power of 2nd Harmonic Trap.
12	LOADING control Adjustment	Adjusts coupling of PA to antenna.

SECTION IV

PRINCIPLES OF OPERATION

4-1. INTRODUCTION

4-2. This section presents principles of operation with supporting diagrams for the HARRIS MW-50C3 MEDIUM WAVE AM BROADCAST TRANSMITTER. Two levels of discussion are provided. The first level provides an overall circuit description and basic theory. The second level provides a detailed description of the transmitter circuits.

4-3. OVERALL FUNCTIONAL DESCRIPTION

4-4. RF SECTION

4-5. The RF Section consists of Oscillator Chassis 1A10, RF Driver 1A9V1 and plate Modulated Power Amplifier 1A9V2 (refer to figure 4-1). These three basic stages with associated power supplies and metering are contained in an Isolated Enclosure which operates above ground potential. This enclosure is at the cathode potential of the Power Amplifier or 15kV for carrier conditions and varies from near zero to full supply voltage during the modulation cycle. Access to the Isolated Enclosure is accomplished through an interlocked rear door or an interlocked front door.

4-6. OSCILLATOR CHASSIS 1A10. The Oscillator Chassis contains two identical oscillator/driver boards and one power supply. The output from the Oscillator Chassis provides approximately two watts of drive to the RF Driver Tube. The Oscillator/Buffer power supply is located in the Oscillator Assembly which permits assembly removal and testing as a unit using the test cable supplied with the transmitter.

4-7. RF DRIVER 1A9V1. The RF Driver consists of one 4CX1500A Tetrode Power Tube as shown in figure 4-1. The plate-to-cathode voltage of this tube is a summation of the Bias Supply and the Screen Supply voltages (1500 Vdc). The plate circuit of the RF Driver is tuned to both the fundamental carrier frequency and the 3rd harmonic of the carrier frequency. Tuning the plate circuit in this manner provides a near square wave pulse to drive the PA.

4-8. POWER AMPLIFIER 1A9V2. The Power Amplifier consists of one 4CX35000C Tetrode Power Tube. This tube operates class D by use of grid and plate 3rd harmonic resonators. The screen of this stage is modulated by the use of a choke in series with the screen grid. The PA plate is tuned to both the fundamental and 3rd harmonic which causes the plate waveform to be nearly square. This increases the conduction angle, decreases the peak current required, and increases the overall stage efficiency to approximately 90 percent.

4-9. PA Screen Automatic Gain Control. The screen current of the PA stage is automatically controlled by a feedback loop to the Oscillator Chassis. The RF Driver power is regulated by this feedback loop which keeps the PA screen current constant and within its dissipation rating even without plate

voltage applied to the PA. This method of controlling the PA screen current makes the stage act as a triode. The PA may thus be tuned and loaded without concern of over dissipating the screen.

4-10. ISOLATED ENCLOSURE POWER SUPPLIES. Two power supplies are contained within the Isolated Enclosure (refer to figure 4-1). A 600 Vdc Bias Supply provides fixed grid bias to the Power Amplifier and a 900 Vdc Supply provides PA screen current. The two supplies are connected in series to provide 1500 Vdc for the RF Driver. Relay K1 is an under-voltage relay that prevents the PA Screen Supply from operating should the Bias Supply fail. The 230 Vac primary power for the Isolated Enclosure power supplies is furnished by isolation transformer 2T1.

4-11. OUTPUT NETWORK. The Output Network, as shown in figure 4-1, is a conventional double Pi circuit that matches the 1000-ohm PA Tube load to the 50-ohm Antenna System. The Power Amplifier is tuned by adjusting the plate tuning capacitor for a dip in PA plate current. The PA is loaded by adjustment of the PA loading control. The 2nd and 3rd harmonic traps are located at the end of the output network to provide adequate harmonic attenuation.

4-12. DIRECTIONAL COUPLER. A Directional Coupler is located in the Transmitter Output Cabinet. The Directional Coupler provides samples of forward and reflected power and a VSWR fault circuit trigger to cycle the transmitter OFF during high VSWR conditions.

4-13. MODULATOR SECTION

4-14. The Modulator Section uses a HARRIS CORPORATION Broadcast Transmission Division patented Pulse Duration Modulator (PDM). The PDM is unique in that it provides conventional plate modulation of an RF Power Amplifier Tube at an efficiency of approximately 90 percent, using no modulation transformer or reactor. Refer to figure 4-1 for the following discussion.

4-15. The PDM circuit generates a 75 kHz square wave that is width modulated by the Audio Input Signal. The square wave width change is linear, with respect to the amplitude of the audio wave. A 10 percent duty-cycle change in pulse width will change the PA voltage by 10 percent of the supply voltage. The pulse width rate of change is equal to the audio input frequency. These pulses are amplified by the Modulator Driver and Modulator stages and filtered out by the 75 kHz filter. Only dc and audio remain at the PA plate, as in conventional plate modulation.

4-16. PULSE DURATION MODULATION. Pulse duration modulation provides conventional plate modulation of the Power Amplifier, but does not require the customary modulation transformer and reactor, eliminating the most troublesome components normally used in a high-level plate-modulated transmitter. Pulse Duration Modulation is nothing more than an efficient series modulator.

4-17. In figure 4-2, assume the PA to be a 4CX35000C Tube operating at 9000 volts at 6.0 amperes. The power supply must provide at least 18,000 volts to provide the required voltage necessary at 100 percent positive peak. The plate voltage of a plate modulated Power Amplifier, swings to twice the

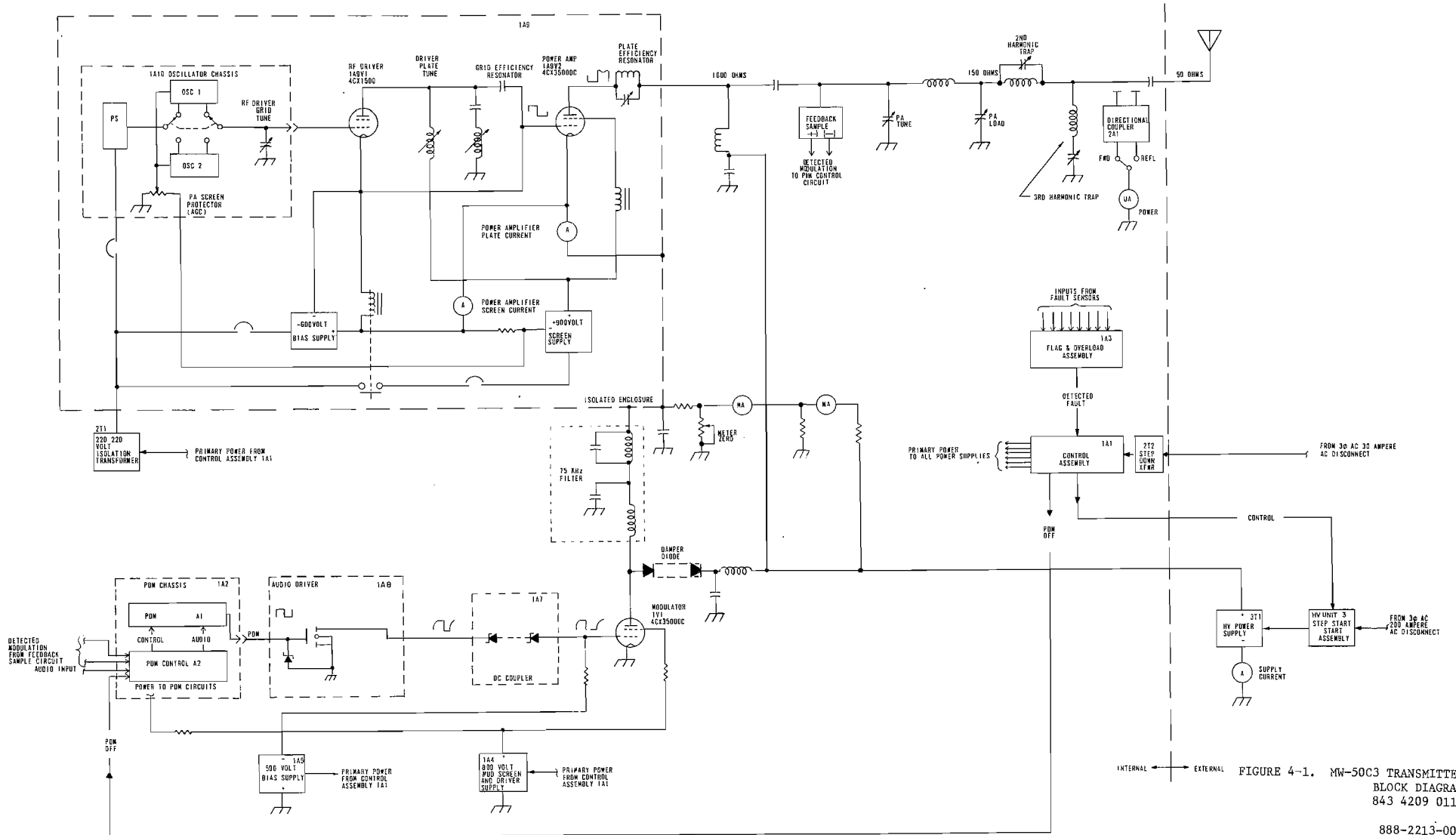

FIGURE 4-1. MW-50C3 TRANSMITTER
BLOCK DIAGRAM
843 4209 0115

888-2213-001
4-3/4-4

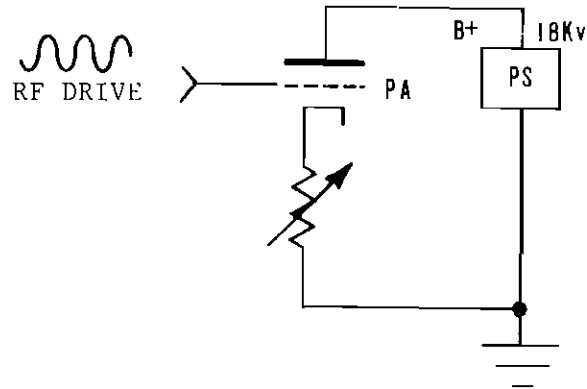

Figure 4-2. PDM Equivalent Circuit

carrier voltage at the 100 percent positive peak down to zero volts at the 100 percent negative peak. Therefore, the power supply must supply at least twice the voltage required at carrier. PDM Equivalent Circuits as shown in figure 4-2 will provide plate modulation if the grid current floats with the cathode of the Power Amplifier.

4-18. To provide carrier, the resistor must be adjusted to drop the power supply B+ down to 9000 volts across the PA tube. There will be 9000 volts across the tube and 9000 volts across the resistor.

4-19. The positive peak is developed by decreasing the resistance to zero ohms, zero volts across the resistor, and 18,000 volts across the Power Amplifier.

4-20. The negative peak is developed by increasing the resistor value to infinity, 18,000 volts across the resistor and zero volts across the Power Amplifier. The speed at which the resistor value is changed is the modulating frequency. The amount of resistance changed from carrier level is the modulation percentage. The efficiency of this circuit is obviously poor as at carrier one-half the power is lost in the resistor.

4-21. Again, assuming that 9000 volts is required for carrier power, as shown in figure 4-3, an 18,000-volt power supply will be required for 100 percent positive modulation. The Modulator Tube accomplished the effect of the resistor in the preceding example.

4-22. If a 75 kHz switching frequency is used and the Modulator is turned on to half-pulse width each 75 kHz pulse, half of the power supply voltage will appear across the PA.

4-23. As the 75 kHz pulse width increases, the PA Plate voltage will increase linearly until full pulse width, continuous pulse, is achieved. This will provide maximum positive peak modulation of the carrier. As the pulse width is decreased from the half-width alternately on and off, the PA plate voltage will decrease from half the power supply voltage to form the negative peak. Zero pulse width is 100 percent negative peak condition. Full pulse

width, continuous pulse, will put full supply voltage across the plate of the PA tube to form the 100 percent positive peak.

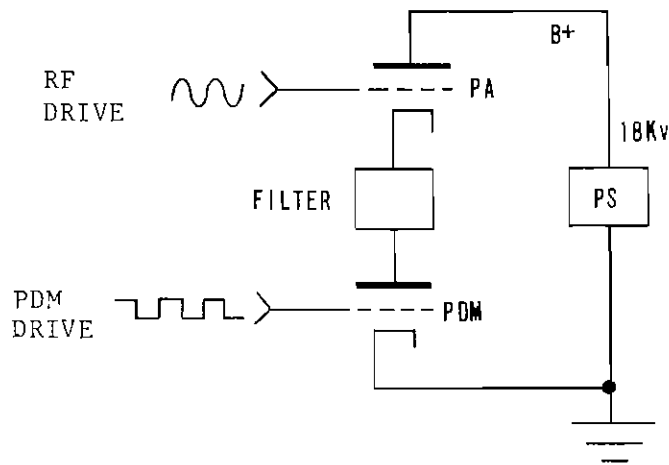

Figure 4-3. PDM Simplified Circuit

4-24. Basically a 10 percent pulse width will put 10 percent of the power supply voltage across the PA Tube and 20 percent pulse width will put 20 percent of the power supply voltage across the PA Tube, etc.

4-25. MW-50C3 PDM CIRCUITRY. The output of a 75 kHz Oscillator (refer to figures 4-1 and 4-4) is clipped to form a square wave and integrated to form a triangle waveform. This voltage (B) is summed with audio (A) at the input of a threshold amplifier (C). The output of the amplifier is a modulated pulse train (D) where amplitude changes in the audio input appear as duty cycle changes of constant amplitude rectangular waves.

4-26. Succeeding stages in the modulator chain are operated in the switching mode, capable of turning on and OFF at 75 kHz rate with less than one or two microseconds rise and fall time. The stages amplify the modulated pulse train to a level sufficient to modulate the PA Tube. The modulators are nearly independent of amplifier linearity as normal linearity is not a consideration in the switching mode of operation.

4-27. PDM CIRCUIT. The PDM Chassis shown in figure 4-1, consists of a PDM board on a control and feedback board. The PDM generates the 75 kHz pulse trains which is modulated with the audio signal to provide pulse width modulation. The control and feedback circuit provides power control and overall feedback to reduce distortion. The output from the PDM is a pulse width modulated square wave that drives the Audio Driver Tube. The output from the Audio Driver Tube is offset by a string of Zener diodes and a dc coupler, which drive the Modulator Tube operating as a square wave amplifier. The plate of the Modulator Tube swings from the high-voltage power supply, approximately 25kV, to near ground potential at a 75 kHz rate with only the width of the pulse changing. The pulses are filtered and the dc and audio are left at the Isolated enclosure. The PA plate voltage is then equal to

the duty cycle of the square wave times the power supply voltage. If the modulator is on 10 percent of the time and OFF 90 percent of the time, 10 percent duty cycle, PA plate voltage will equal 10 percent of the high voltage.

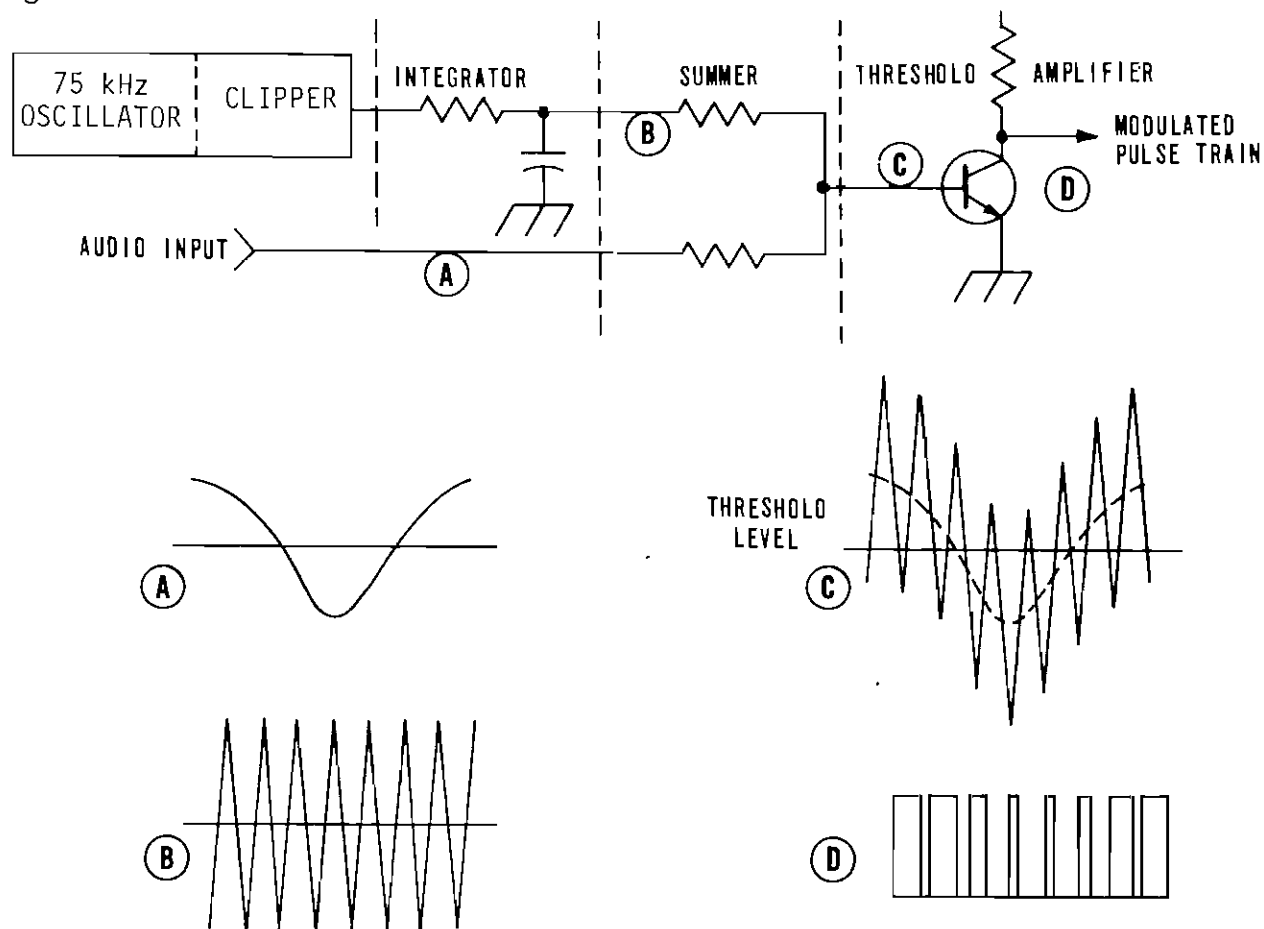

Figure 4-4. MW-50C3 Transmitter PDM

4-28. DAMPER DIODE. The Solid-State Damper Diode Assembly is connected between the modulator plate and the positive side of the High-Voltage Power Supply (refer to figure 4-1). The Damper Diode conducts alternately with the Modulator, ON when Modulator is OFF and OFF when the Modulator conducts, at the 75 kHz rate. When the Modulator Tube suddenly stops conducting, current to the 75 kHz Filter cannot stop and voltage at the plate of the Modulator Tube increases towards infinity. When the voltage of the plate of the Modulator Tube attempts to go higher than the High-Voltage Power Supply potential, the Damper Diode conducts, eliminating high-surge voltage build up which could damage the modulation system. The alternating modulator/damper conduction provides a steady current load on the High-Voltage Power Supply. The damper current accounts for the difference in plate and supply currents, even though the PA and Modulator stages are connected in series.

4-29. MODULATOR POWER. Two power supplies are associated with the Modulator. One is a 500 Vdc Bias Supply that provides a negative bias to the

Modulator Tube. The second supply is an 800 Vdc Supply that provides screen voltage for the Modulator.

4-30. CONTROL CIRCUITS

4-31. The Control Circuits consists of Control Assembly 1A1 and High-Voltage Step/Start Assembly 3. Refer to figure 4-1 for the following discussion.

4-32. CONTROL ASSEMBLY 1A1. The Main Power Control Assembly contains all the low-level circuit breakers for the power supplies and filaments of all tubes. The Control Assembly also controls the filament step/start and the high voltage step/start.

4-33. HIGH-VOLTAGE STEP/START ASSEMBLY 3. The High-Voltage Step/Start Assembly is an external device that contains step/start resistors and contactors for the Main High-Voltage Power Supply. AC Overload Sensors are also contained within this assembly.

4-34. FAULT CIRCUITS

4-35. FAULT AND OVERLOAD ASSEMBLY 1A3. The Fault and Overload Assembly shown in figure 4-1, receives status information from various sensors throughout the transmitter. The circuit monitors transmitter operation, provides visual indications of where a fault or overload occurred and initiates action to turn off high voltage and shut down the transmitter if a fault is detected. Parameters monitored include (1) VSWR, (2) high-voltage current, (3) arcs in the PA circuit, (4) output circuit arcs, (5) Modulator Screen current, (6) arcs at 75 kHz Filter gaps, and (7) arcs across Plate Efficiency Resonator gap.

4-36. Multiple Faults. An automatic recycle feature is included. This feature turns off the high voltage momentarily to see if the fault can be cleared. It then turns the high voltage back on. If the fault still exists, another recycle is attempted. Up to three or four recycles can be attempted before the transmitter shuts down automatically and the high voltage must be turned back on manually.

4-37. HIGH-VOLTAGE POWER SUPPLY

4-38. The High-Voltage Power Supply primary and secondaries are connected in a closed delta configuration. Each secondary winding leads or lags the primary winding by 15 degrees in phase, 30 degrees total, as constructed (refer to figure 4-5). The secondary phase separation divided into one cycle of primary phase rotation (360 degrees) equals 12 secondary phases.

4-39. FILTER CIRCUIT. The 12-phase output approaches true dc as ripple voltage is reduced to 1 percent without using a filter inductor (refer to table 4-1). The principal output filter ripple frequency equals the line frequency times the secondary supply phases (12). The output filter section acts as both a ripple filter and a transient suppressor. Noninductive components are used in the Filter Circuit to ensure that the filter does not become resonant at a rf frequency.

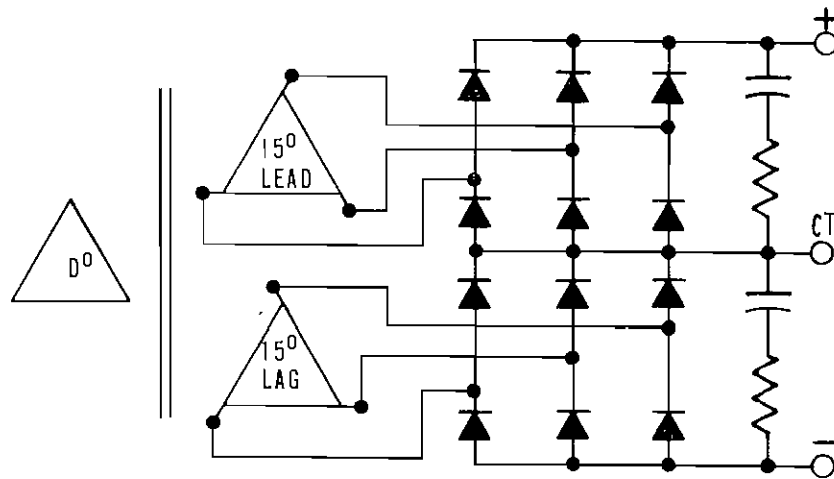

Figure 4-5. 12-Phase Circuit

Table 4-1. Characteristic Multiphase Supply Ripple

SECONDARY PHASES	LINE POWER FACTOR	SINGLE SECTION FILTER RIPPLE VOLTAGE (RESISTIVE OR INDUCTIVE LOAD)	
		PEAK TO PEAK	RMS
3	.83	50.0%	17.7%
6	.96	11.4%	4.0%
12	.99	3.4%	1.0%

4-40. PRIMARY REQUIREMENTS. A requirement of multiphase supplies is that the three-phase primary line voltage must be balanced to within the percentage of ripple voltage which is to be obtained from the power supply. Line unbalance will show up as 100 Hz, 50 Hz primary, or 120 Hz, 60 Hz primary, ripple in the rectifier circuit and produce increased output ripple. A 5 percent primary line voltage unbalance will produce approximately 3 percent peak ripple in the secondary circuit into a resistive load at twice the power line frequency. Constant line unbalance can be corrected by the use of primary taps or a tapped three-phase auto transformer.

4-41. METERING CIRCUITS

4-42. These circuits provide visual indications of critical transmitter parameters including high voltage, high-voltage supply current, power amplifier plate voltage, power amplifier screen current, output power, modulator filament voltage, and power amplifier filament voltage. Meter circuits are also provided to monitor voltages and currents in the Modulator and its drive circuits and in the RF Section.

4-43. DETAILED FUNCTIONAL DESCRIPTION

4-44. RF SECTION

4-45. OSCILLATOR 1A10. The Oscillator Chassis (figures 4-6 and 9-5) contains two identical printed-circuit boards, 1A10A1 and 1A10A2, and one power supply. An output from either of the two oscillators may be selected by the front panel OSCILLATOR 1/2 switch. Transistor Q1 operates as a Pierce oscillator using an on-frequency vacuum crystal in its series resonant mode to generate an output at the carrier frequency. Zener diodes CR1, CR2, and CR3 regulate the operating potential for low-level stages at 15 Vdc. The output from the oscillator stage is lightly coupled to buffer amplifier transistor Q2 through resistor R7. The output from transistor Q2 drives transistor Q3 and the RF Amplifier. The output from transistor Q3 drives a class C tuned amplifier, transistor Q1 or Q2, as selected by the OSCILLATOR 1/2 switch. Diode CR5 prevents either transistor Q1 or Q2 from being overdriven.

4-46. Oscillator AGC Circuit. Diode CR4 gates a current sample from the Power Amplifier screen supply to act as an AGC feedback voltage to control the gain of transistors Q1 and Q2. The current sample is adjusted by PA SCREEN PROTECTOR potentiometer R1 to provide proper PA screen current.

4-47. Oscillator RF Output Circuit. A "Pi" section, consisting of coil L1 or L2, acting as a tuning control, and capacitor C1 which operates as a loading control, matches the collector output of transistors Q1 and Q2 which is approximately 100 ohms, to the grid of RF Driver tube 1A9V1 which operates at approximately 2400 ohms. Changing capacitors 1A10A1C12 and 1A10C2 permits operation over the medium frequency band.

4-48. Oscillator Power Supply. The Oscillator Power Supply consists of a transformer powered, full-wave rectified supply with a choke input filter. This power supply produces 100 Vdc, even though the maximum voltage used on any transistor is 39 Vdc. The high voltage is used to provide an adequate current source to all stages to prevent under-voltage in any stage caused by mistuning.

4-49. RF DRIVER 1A9V1. RF Driver Tube 1A9V1 operates class AB₁ with a combination of cathode and grid leak bias (refer to figures 4-6 and 9-5). The driver plate voltage of 1500 Vdc is obtained by connecting the -600 Vdc PA Bias and +900 Vdc Screen Supplies in series respectively from cathode to plate across the tube. A cathode resistor develops tube bias. This method allows elimination of the PA grid leak resistors. The Driver Tube itself loads the PA Bias Supply, eliminating resistor and associated power loss. The driver screen grid is protected against over-dissipation by current limiting resistor 1A9R7.

4-50. RF Driver Neutralization. Neutralization of the RF Driver is not required as resistors 1A9R5, R6, R7, R8, R9 and R10 sufficiently swamp the grid to prevent parasitic oscillations. In addition, parasitic suppressors are used in the driver grid, screen and plate circuits to prevent possible high-frequency parasitic oscillation.

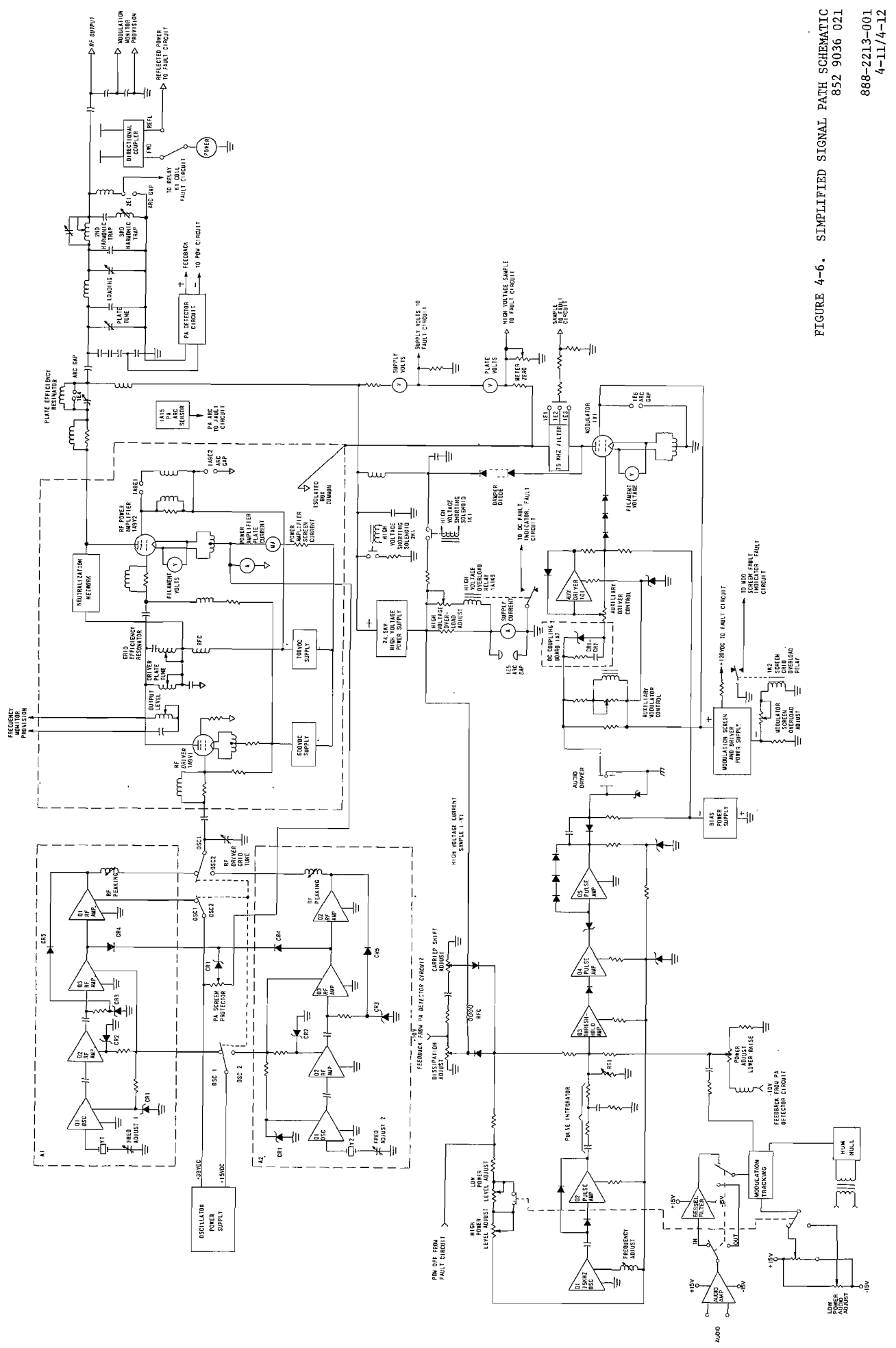

FIGURE 4-6. SIMPLIFIED SIGNAL PATH SCHEMATIC
852 9036 021
888-2213-001
4-11/4-12

4-51. RF Driver Plate Circuit. The RF Driver plate circuit (figure 4-7A) contains a resonant circuit, consisting of coil 1A9L1 and capacitor 1A9C5, which tunes to the fundamental frequency and a circuit, consisting of coil 1A9L2 and capacitor 1A9C4, which resonates at the 3rd harmonic of the fundamental frequency. The 3rd harmonic component tends to square-up the pulse applied to the PA grid to increase PA stage efficiency. PA grid capacity, coil 1A9L1, and capacitors 1A9C5, 1A9C7, and 1A9C9 form a tuned circuit for the fundamental frequency and matches the PA grid impedance. Capacitors 1A9C7 and 1C9C9 also provide dc blocking and form a capacitive voltage divider to feed the PA grid.

4-52. Double Resonant Circuit. The fundamental and 3rd harmonic components form a double resonant circuit. At the fundamental frequency (figure 4-7B), coil L2 appears to increase the reactance of capacitor C4 which resonates coil L1 along with the series stack formed by capacitors C7, C5, C9 and PA grid capacity (Cg). At the 3rd harmonic (figure 4-7C), coil L2 appears lowered in reactance by capacitor C4, and parallels coil L1 to form a low inductance which resonates with the series stack formed by capacitors C7, C5, C9 and PA grid capacity (Cg).

4-53. POWER AMPLIFIER 1A9V2. The Power Amplifier consists of one tetrode power tube operated class D (refer to figures 4-6 and 9-5). Fixed bias for the stage is provided through coil L4 from the -600 Vdc Bias Supply. The PA Screen is modulated by 10H choke 1A9L6 shunted with resistor R45 in series with the screen supply. Modulation of the screen is necessary to fully modulate the PA and also improves modulation linearity.

4-54. The PA Tube grid is driven with a symmetrical waveform consisting of fundamental plus 3rd harmonic waveforms. Squaring of the waveforms at the plate is achieved by a paralleled tuned circuit in series with the plate lead. The parallel circuit elements are connected in series with a number of other circuit elements such as plate capacity, bypass capacity and plate tuning capacity. Squaring the waveform increases efficiency by reducing the plate current conduction angle to 90 percent and also lowers the peak plate current. This allows much higher power to be developed from the tube and increases the already conservative ratings of the 4CX35000C tube.

4-55. PA Screen Protection. To prevent over dissipation of the PA Screen, PA Screen current is sampled across resistor R23 and is fed back to the Oscillator Chassis through resistor 1A9A2R17 to operate as an AGC circuit acting on low-level stages in the oscillator assembly. This circuit keeps the PA Screen current constant and within its dissipation, even with no plate voltage applied to the tube. This allows the plate circuit of the PA to be tuned without over-dissipating the screen. Tuning this stage is similar to tuning a triode.

4-56. PA Neutralization. The Power Amplifier is neutralized at the 3rd Harmonic by the Bruene method with capacitors C35, C36, C37 and C39. This circuit is effective over a wide frequency range. Neutralization at the fundamental frequency is not required.

A. ELECTRICAL CIRCUIT

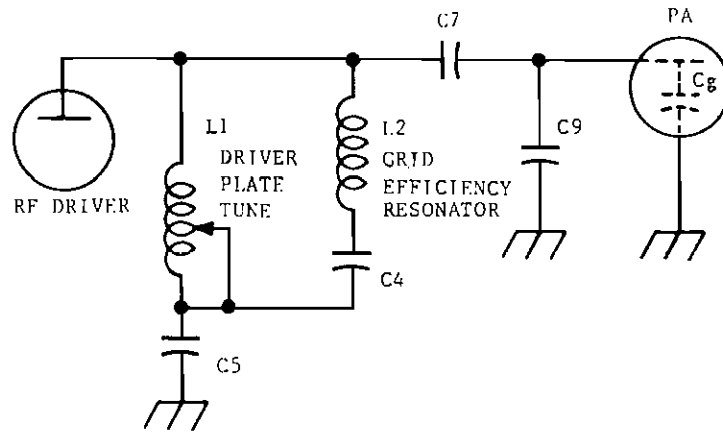

B. FUNDAMENTAL FREQUENCY EQUIVALENT CIRCUIT

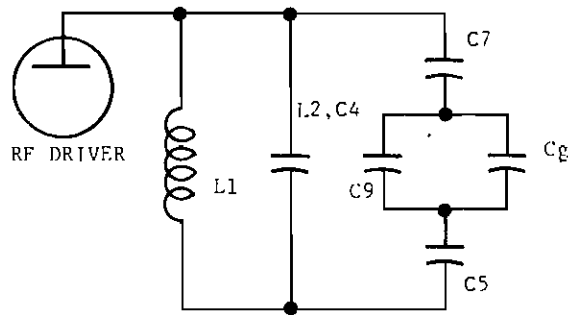

C. THIRD HARMONIC EQUIVALENT CIRCUIT

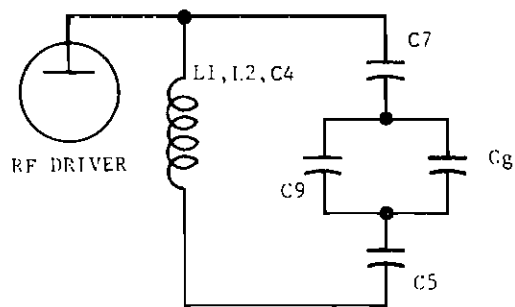

Figure 4-7. RF Driver Plate Circuit

4-57. OUTPUT NETWORK. The MW-50C3 Transmitter Output Network is basically a double "Pi" circuit (refer to figures 4-6 and 9-1). The plate load is 1000 ohms and is stepped down to 150 ohms at the center point, which is capacitor 2C3, and then is stepped down to 50 ohms at the output. As the phase-shift between the plate tune and loading controls is approximately 135° , a change in loading does not require a change in tuning, when phaseshift through a network is an odd multiple of 45° , a minimum change in network reactance occurs if the terminating impedance is varied. The 2nd Harmonic Trap is formed by capacitor 2C4 and coil 2L4. The 3rd Harmonic Trap is formed by capacitor 2C5 and coil 2L5. Plate capacity and other components within the Isolated Enclosure and capacitor 2C1 together with coil 1L3 act as the plate circuit 3rd Harmonic resonator. With the grid and plate circuits tuned to both the fundamental frequency and the 3rd harmonic, the PA operates nearly class D. This causes the plate waveform to square slightly which increases tube efficiency to about 90 percent and reduces peak tube currents by approximately 50 percent.

4-58. Output Network Adjustment. For proper operation, the 75 kHz Filter must be terminated in its characteristic impedance. The filter termination is the Isolated Enclosure and the impedance is approximately PA plate voltage divided by the PA plate current. Therefore, the Isolated Enclosure will present the correct impedance only when the PA is loaded properly and the efficiency resonators are correctly tuned. A ratio of 9.3kV of plate voltage to 6.3 amperes of plate current usually provides a close approximation. However, each individual transmitter is provided with a set of final test data sheets which should be consulted for exact tuning values for optimum performance.

4-59. To tune the PA Output Network, the PLATE TUNE Control is adjusted for minimum PA plate current but may be adjusted slightly off resonance for maximum efficiency. The LOADING Control is adjusted until the Power Amplifier Tube is typically loaded to 6.3 amperes of plate current with 9.3kV of plate voltage. The PDM High-Power Level Adjust should be used to keep the plate voltage at 9.3kV while the LOADING control is adjusted to obtain 6.3 amperes of plate current. The 2nd and 3rd Harmonic Traps should be tuned only when proper proof-of-performance equipment is available. The trap controls are each tuned for minimum output of the particular harmonic.

4-60. PA Efficiency Resonator Adjustment. The PA Efficiency Resonators have an effect on both distortion and noise as the 3rd Harmonic content must be adjusted to provide the same plate voltage-to-plate current ratio over a simultaneous PA plate voltage swing. Resonator adjustment is not difficult

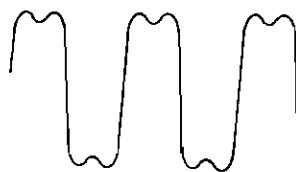

Figure 4-8. PA Output Waveform

as long as a 1/2-turn CW or CCW from the original setting restriction is strictly observed. The waveform at the PA plate appears as shown in figure 4-8. The waveform consisting of the fundamental and 3rd Harmonic may be observed with an oscilloscope by placing the oscilloscope probe on the air output screen immediately above the PA Tube.

4-61. After the PA Grid Efficiency Resonator is properly tuned, the PA Plate Efficiency Resonator may be tuned for maximum efficiency of the Power Amplifier stage. This may be checked by watching the power output and PA input. The following formula is used to calculate PA efficiency:

$$\text{PERCENT EFFICIENCY} = \frac{\text{POWER OUTPUT IN WATTS}}{\text{PA CURRENT X PA VOLTAGE}} \times 100$$

4-62. DIRECTIONAL COUPLER 2A1.

4-63. The Directional Coupler consists of three basic circuits (figure 9-10): 1) a voltage sample proportional to forward power, 2) a voltage sample proportional to reflected power, and 3) a VSWR Trigger Unit.

4-64. FORWARD POWER SAMPLE. The current sample is derived from transformer T2 that develops a voltage across resistors R16 and R17. A voltage sample is produced by capacitor divider C15, C10, and C11. These samples are added through diode CR4 to produce a voltage proportional to the power at terminals 6 and 5 on the Directional Coupler. The voltage at terminal 6 is adjustable by potentiometer R21 to properly calibrate the transmitter forward power meter. The second sample at terminal 5, goes directly to the Remote Power meter, if used.

4-65. REFLECTED POWER SAMPLE. The Reflected Power Sample is identical to that of the Forward Power Sample except that the current sample from transformer T2 is reversed by 180 degrees, in phase, so that the meter indication is only that power which has been reflected by the Antenna. This sample is routed through meter calibration potentiometer R20 and through jack TJ3 to terminal 3 on the output Directional Coupler. A second sample, at terminal 4 of the Directional Coupler, feeds the Remote Power Indicator.

4-66. VSWR TRIGGER UNIT. The VSWR Trigger Unit consists of a power sample similar to the Reflected Power Sample. The output at terminal 9 is a voltage proportional to the change in reflected power rather than proportional to the change itself. Phase adjustment by capacitor C2 and null adjustment by capacitor C4 allow the circuit to be adjusted for zero output voltage even with a small reflected power appearing from the Antenna. A voltage will appear at terminal 9 if the reflected power changes either way from that determined in null position. Should the VSWR change greater than approximately 1.2:1 from this preset value, the voltage at terminal 9 will increase to approximately two volts and cause SCR transistor Q1 to trigger and place a near ground at terminal 2. The current through transistor Q1 also flows through the base circuit of transistor Q2, causing it to conduct and energize relay K1. When relay K1 is energized, the normally open contact closes and places a short across transistor Q1, allowing it to cut off and the cycle is repeated. To zero the VSWR Trigger Unit, jack TJ3 is moved from its

normal position of jumping potentiometer R20, to terminal 3 and configured to jumper resistor R3 to terminal 3. The VSWR Trigger is adjusted to zero as indicated on the Transmitter Power meter, in the reflected position.

4-67. MODULATOR SECTION

4-68. The Modulation System used in the MW-50C3 MEDIUM WAVE AM BROADCAST TRANSMITTER is a patented HARRIS design called a Pulse Duration Modulator (PDM). The PDM is basically a voltage regulator in series with a power supply and load. In this case, the load is the Power Amplifier and the regulator is the Modulator. The regulator, when used as a Modulator, must have good frequency response from zero to 10 kHz so the Modulator will properly respond to the audio frequencies to control the PA plate voltage. A modulator switching frequency of 75 kHz is employed as a good compromise between frequency response and efficiency.

4-69. The Modulator itself acts similar to an SCR light dimmer, controlling voltage to a light bulb from zero to full brightness, by changing the conduction angle of the SCR. A small conduction angle or short-duty cycle will cause the lamp to glow very dimly, whereas a full-duty cycle will produce maximum brilliance. With the light adjusted to half its possible brilliance, adjustment of the SCR up and down from the half-brilliance setting will amplitude modulate the light bulb. The speed at which the light is adjusted up and down corresponds to the modulating frequency and the amount of adjustment corresponds to the percentage of modulation.

4-70. MODULATION ENHANCER. When the OPERATIONAL BYPASS switch (refer to figures 3-3 and 9-11) is in the OPERATIONAL position, the Audio Input is applied across switch-selectable pads controlled by the CAL OUT-ENHANCING/-1dB/2dB/ 3dB switch. In the CAL OUT position, the Audio Signal is routed directly to the transmitter without clipping to permit adjustment of the modulation prior to enhancement. When the ENHANCING 1 dB, 2 dB, or 3 dB position is selected, the audio line is applied to diodes CR6 and CR8 at the inputs to the positive and negative clipping circuits formed by transistors Q1 through Q4.

4-71. The clipping threshold for the positive and negative peaks of the audio input are independently adjusted by NEG PEAK potentiometer R16 and POS PEAK potentiometer R20. These potentiometers are connected to the +12-volt power supply formed by transformer T1, bridge rectifier CR1 through CR4, and Zener diodes CR5 and CR7 and are adjusted to set the switching levels of transistor Q1/diode CR5 and transistor Q3/diode CR8. When the audio input goes sufficiently positive to overcome this switching level, diode CR6 and transistor Q1 conduct to prevent any further positive increase. With transistor Q1 ON, transistor Q2 turns ON and NEG PEAK LED indicator DS2 illuminates. Diode CR8, transistors Q3 and Q4, and POS PEAK LED indicator DS3 function similarly to clip negative excursions at the threshold set by POS PEAK Control potentiometer R20. The Modulation Enhancer is factory installed such that with normal audio inputs, the NEG PEAK Control adjusts clipping of negative modulation peaks and the POS PEAK Control adjusts clipping of positive modulation peaks.

4-72. POWER Indicator LED DS1 is illuminated whenever primary power is applied and the internal +12-volt power supply is functioning properly.

4-73. PDM CHASSIS. PDM Chassis consists of two printed-circuit boards. The PDM signal is generated and amplified on board A1. Board A2 contains the audio input pad, audio amplifier, and PDM controls. Refer to figures 4-6, 4-9 A-H, and 9-6 for the following discussion.

4-74. PDM Board A1. On PDM Board A1, transistor Q1 forms a 75 kHz LC oscillator. Crystal control is not necessary as the frequency output is not critical. Capacitor C4 functions as a blocking capacitor and couples the 30V p-p output signal to the base of transistor Q2 (refer to figure 4-9A). Transistor Q2 is overdriven by the 30V sine wave and forms a 20V p-p square wave at capacitor C7 (refer to figure 4-9B). Diodes CR1 and CR2 prevent transistor Q2 from saturating under this overdriven condition.

4-75. Resistor R7 and capacitor C8 integrate the square wave to form a 5V p-p type of sawtooth waveform resembling a triangle at the junction of resistor R7, capacitor C9, and resistor R9 (refer to figure 4-9C). Audio signal, audio feedback, and dc feedback are added to the triangle waveform through resistors R12 and R10. DC Bias voltage from the PDM power output controls apply an amount of positive voltage, depending on the control settings to point B. This voltage is summed with triangle waveform through resistor R11.

4-76. Transistor Q3 is a compensated threshold amplifier which conducts when the voltage at the base reaches approximately 0.7 volts and cuts off when the base voltage drops below the turn-on point. Audio added to the triangle wave varies above and below the 0.7-volt threshold point of transistor Q3 (refer to figure 4-9DE). As the triangle wave goes above the threshold of transistor Q3 (refer to figure 4-9F), the voltage at the collector of transistor Q3 becomes a square wave with a duration equal to the percent of the triangle wave above the threshold of conduction. Transistor Q3 outputs a 75 kHz pulse train, the pulse width varying linearity according to the audio input and dc bias.

4-77. Audio input from PDM board A2, dc feedback from the dissipation control, and a dc level proportional to the setting of the Power Output Control are all summed with the triangular waveform at the base circuit of threshold amplifier transistor Q3. The audio input from PDM board A2 also includes a feedback inversely proportional to the audio output of the PA stage. The audio feedback, previously shaped for a desired response, minimizes the carrier shift and improves modulation linearity and response. The dc feedback from the Dissipation Control is inversely proportional to the dissipation of the Power Amplifier. If Power Amplifier dissipation increases above a pre-set value, the threshold amplifier duty cycle changes to decrease the power output.

4-78. During operation, a bias is established which causes transistor Q3 to output a 75 kHz pulse with about a 35 percent duty cycle. When the audio is added to the triangle wave, it causes the output from transistor Q3 to vary in pulse-width around this bias setting to plate-modulate the PA. The PA is capable of being controlled in excess of 125 percent modulation.

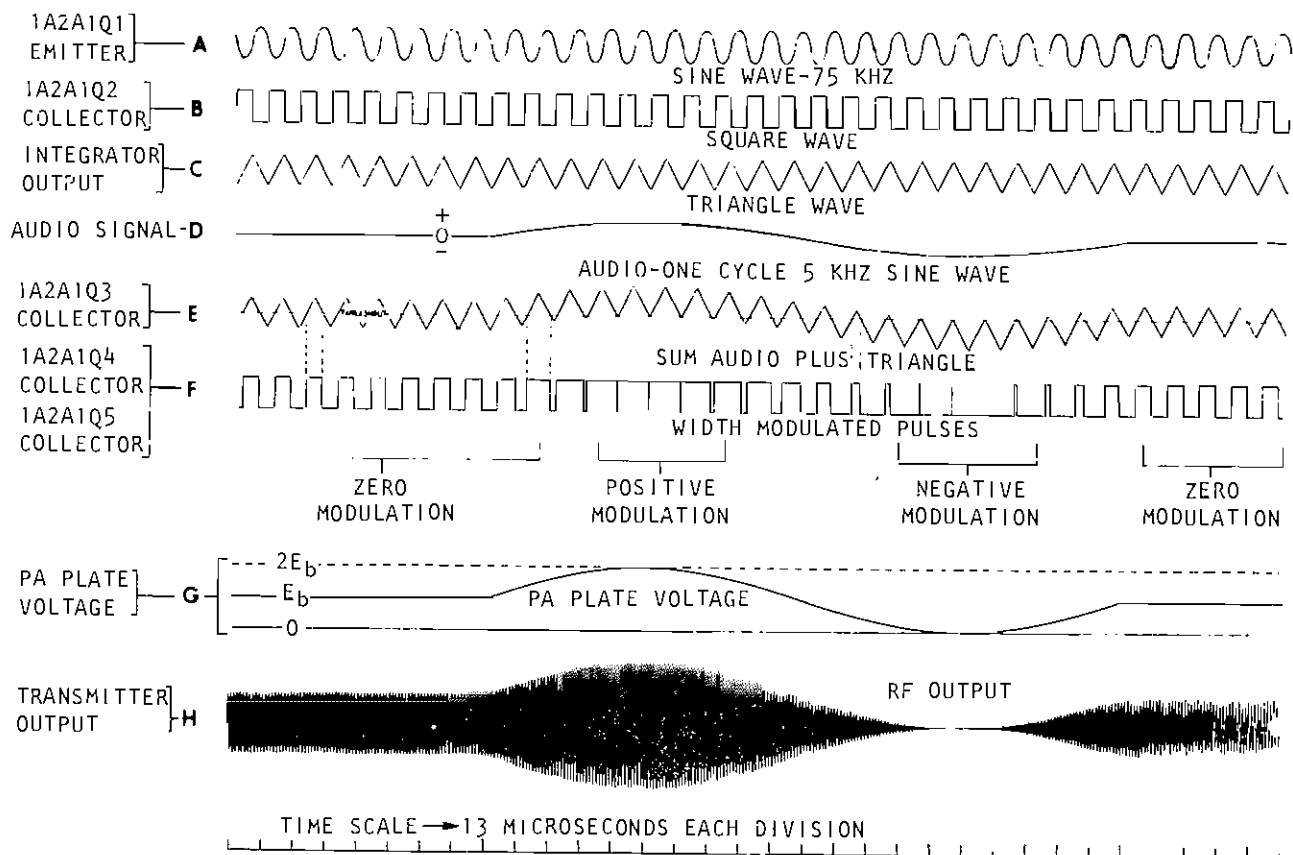

Figure 4-9. PDM Waveform

4-79. Transistor Q4 is overdriven by the collector voltage of transistor Q3 to further square the waveform and provide adequate drive to transistor Q5. Zener diode CR4 provides a stabilized voltage for transistors Q3 and Q4. Diodes CR6, CR7, and CR8 prevent transistor Q5 from saturating. When transistor Q5 conducts, the voltage at point F is near zero. When transistor Q5 cuts off, resistor R23 pulls point F towards the 12-volt potential established by diode CR10.

4-80. PDM Board A1. Transmitter audio is applied to operational instrumentation amplifier integrated circuit U1 through an audio pad consisting of resistors R1, R2, R3, R4, and R5 and a RFI filter consisting of coils L1 and L2 and capacitors C1, C2, C3, and C4. Operational instrumentation amplifier integrated circuit U1 provides a balanced to single-ended transformation with high common-mode signal rejection. Potentiometer R11 determines the input amplifier gain and therefore the audio input level for 100 percent modulation. Potentiometer R18 determines the low-frequency common-mode rejection ratio.

4-81. Printed-circuit board mounted switch S1 enables Bessel low-pass filter integrated circuit U2, which effectively removes high-frequency low duty-cycle energy to reduce complex wave overshoot in the high-level PDM filter.

4-82. PDM FEEDBACK. Three feedback inputs are provided to the PDM chassis (figures 4-6, 9-3, 9-6). A capacitive voltage divider comprised of capacitors 2C18, 2C19, 2C20, and 2A3C1 at the plate of the PA furnishes a rf voltage which is detected and filtered by 2A3CR1, 2A3CR2, and 2A3C2. At full output power, this feedback voltage which is proportional to output power applies about +10 Vdc to the PDM chassis at point M and -10 Vdc at point N (figure 9-6). The -10 Vdc is applied to point N to provide power trim control and provides a degree of automatic gain control to keep carrier shift low. The voltage applied to point N also provides negative feedback when the transmitter is modulated, to improve modulation linearity, noise figure, and audio response. It is also applied to the automatic modulation tracking circuit. The +10 Vdc is applied to the Dissipation Circuit and the Carrier Shift circuit to provide protection against over-dissipation of the PA tube and carrier amplitude shift correction.

4-83. Audio information is stripped from the -10 Vdc feedback signal by a low-pass filter consisting of resistors R30 and R31, and capacitors C18 and C19. The resulting dc voltage represents the carrier level and is applied to integrated circuit U3 which is the automatic modulation tracking circuit.

4-84. A sample of High-Voltage Power Supply current appears at point L on the PDM chassis. This voltage is developed across 1 ohm resistor 1R9 which is in series with the negative side of the High-Voltage Power Supply which will produce 1 volt for each ampere of supply current. The positive dc feedback voltage at point M is applied through resistor R33 to Dissipation Control potentiometer R34. The variable positive voltage from Dissipation Control potentiometer R34 and the dc supply current sample voltage at point L are added, through resistors, at the positive terminal of integrator capacitor C32. If this voltage becomes more than 0.6 volts less than the PDM control line, diode CR6 will conduct and reduce transmitter output power accordingly. Dissipation of the final PA Tube is monitored by metering transmitter

power output and supply current.

4-85. VIEWING PDM WAVEFORMS. Viewing PDM waveforms with an oscilloscope is an excellent method which may be used to check transmitter performance. A few ground rules are listed so unsatisfactory results are not obtained when attempting to duplicate the waveforms.

- a. The Oscilloscope used must have good response up to 30 MHz and display rise times as short as 0.5 microseconds. Use a low capacitance probe with approximately 7 pF of capacity and 10 megohms resistance.

WARNING

DISCONNECT AND LOCK OUT STATION PRIMARY
POWER TO THE TRANSMITTER. USE GROUNDING
STICK TO DISSIPATE POTENTIAL FROM ALL
TAPS AND COMPONENTS BEFORE TOUCHING THEM.

- b. Voltages in the transmitter are dangerous to personnel and can damage equipment. An oscilloscope should be connected to a resistance or capacity type voltage divider if attempting to observe high-voltage signal waveforms.
- c. It is possible to overload the transmitter by adjustment of the Power Output controls. Care must be exercised while observing waveforms at low-level stages in the Modulator chain. A small change in voltage at this point has a large effect on the power output of the transmitter by changing the effective resistance of the Modulator which is in series with the PA. As a precaution, turn off the high voltage by disabling the 200-Ampere Main Service. Perform the normal transmitter Turn-On procedure, including depressing the HIGH VOLTAGE ON pushbutton switch/indicator, even though the high voltage will not be present because the 200 Ampere Main Service is still off.

4-86. PDM Waveforms. Signal waveforms for the Pulse Duration Modulator (PDM) are shown in figure 4-9 as an explanation of circuitry theory. To view the pulses on an oscilloscope, High-Power Level Adjust potentiometer R44 must be adjusted clockwise to lower the duty cycle to an observable rate. Refer to figures 4-9, 4-6, and 9-2 for the following discussion.

4-87. The output (A) of the 75 kHz Oscillator at the junction of capacitor C4 and resistor R4 is essentially sinusoidal. The output of transistor Q2 at the junction of capacitor C7 and resistor R7 (B) is clipped to a square wave. The square wave output of transistor Q2 is integrated by resistor R7 and capacitor C9 to produce a 5V p-p triangle waveform (C) at the junction of resistors R7 and R9. Audio applied at the base of transistor Q3 is shown at D. As the audio summed with the sawtooth waveform crossed the operation threshold of transistor Q3 (E), the transistor outputs the modulated pulse

train shown and low-level power adjustments which control the threshold bias of the stage. Transistors Q4 and Q5 amplify the waveform shown at F to a level sufficient to drive the Modulator Driver. PA plate voltage and RF Output are shown at G and H.

4-88. MODULATOR DRIVER 1A8. The Modulator Driver active device is a Mosfet Pulse Amplifier. The output of the PDM Chassis drives the gate of the Mosfet directly. Source voltage for the Modulator Driver is provided by the Modulator Screen and Driver Power Supply through reactor coil 1L2 and resistors 1R27 through 1R32. The Modulator Driver swings from approximately zero volts to approximately +600 volts and must be offset to Drive Modulator Tube 1V1. The offset function is performed by DC Coupler 1A7.

4-89. DC COUPLER 1A7. DC Coupler 1A7 consists of five 100-volt Zener diodes connected in series. With this arrangement, the Modulator grid will reflect a +100-volt potential when the Modulator Driver is at +600 volts and -500 volts when the Modulator Driver nears saturation (zero volts). This voltage swing is required to switch the Modulator ON and to drive the stage into cut-off. The DC Coupler ensures rapid turn-on from an established threshold which is a requirement for fast switching functions. Modulator Tube efficiency is determined by how fast the tube is turned ON and OFF during periods of conduction.

4-90. AUXILIARY MODULATION. Auxiliary Modulation potentiometer 1R35 consists of a variable resistance across inductor 1L2 in the plate circuit on the audio driver (refer to figure 4-6). This circuit tends to vary pulse amplitude and aids in modulation. Basically, the Auxiliary Modulator assists 100 percent negative modulation and improves frequency response. The control is adjusted to minimize distortion.

4-91. AUXILIARY DRIVER TRANSISTOR 1A14Q1. This stage provides additional current to the Modulator grid during positive modulation peaks to reduce distortion, assists in providing high-positive peak modulation capability, and positive-to-negative peak modulation symmetry (figures 4-6 and 9-10).

4-92. Voltage is dropped across AUXILIARY DRIVER potentiometer 1A14R17 when the control grid of the Modulator Tube conducts (refer to figures 4-6 and 9-10). This causes transistor 1A14Q1 to conduct and pull the modulator grid positive on positive modulation peaks. The amount of pullup caused by transistor 1A14Q1 is limited by Zener diode 1A14CR1. The AUXILIARY DRIVER Control provides adjustment of the amount of auxiliary drive.

4-93. MODULATOR TUBE 1V1. Modulator Tube 1V1 is a power tetrode operating as a high-power pulse amplifier (refer to figure 4-6 and 9-10). The output from the DC Coupler and Auxiliary Driver operates the Modulator Tube grid from +100 volts to -500 volts. Fixed bias is provided by the Bias Power Supply through resistor 1A14R13. Screen voltage for Tube 1V1 is provided by the Modulator Screen and Bias Power Supply through resistors 1R17 through 1R23. These resistors limit screen current and voltage to ensure that the screen is not over-dissipated. The choice of modulator screen voltage must be high enough to provide sufficient power gain by the Modulator Tube, but not so high as to limit the lower value to plate voltage swing. The closer

to zero the lower limit of plate voltage swing, the greater the percentage of modulation.

4-94. The Modulator Tube plate is connected to the 75 kHz Filter, consisting of coils 1L4 and 1L5, capacitors 1C3, 1C4, and 1C22. This network filters the 75 kHz pulses more than 80 dB with a bandwidth from zero to approximately 20 kHz. The low inductance of the first section of the 75 kHz Filter allows the plate waveform to square for maximum stage efficiency. When the Modulator Tube is cut off, energy stored in the 75 kHz Filter could cause the plate voltage of the Modulator Tube to approach infinity. A Damper Diode is used to prevent arc-over in the Modulator Tube.

4-95. DAMPER. The Damper Diode is connected between the plate of the Modulator Tube and the High-Voltage Power Supply (refer to figure 4-6). Should the voltage at the plate of the Modulator Tube attempt to exceed the supply voltage, the Damper Diode will conduct the current back to the power supply. When the Modulator Tube is not conducting the Damper Diode conducts. Conversely, when the Modulator Tube conducts, the Damper Diode is cut off.

4-96. MODULATOR POWER SUPPLIES. Two power supplies are used in the modulator section (refer to figures 4-6 and 9-3). One is a negative 500-Volt Bias Power Supply consisting of transformer T1, bridge rectifier diode CR1, and a choke input filter consisting of coil L1, and capacitors C2 and C3. The second power supply is the Modulator Screen and Driver Power Supply which consists of transformer 1T2, bridge rectifier diode 1A4CR1, and a choke input filter comprised of coil 1L6, and capacitors 1A4C2, C3, and C4. This power supply provides approximately 800 volts at 2.4 amperes.

4-97. CONTROL CIRCUITS

4-98. The control system consists of Main AC Control Chassis 1A1, Fault and Overload Assembly 1A3, with its associated unit prefixed 3, overload and arc sensors, and High-Voltage Power Supply Step/Start. These circuits control the application and removal of primary power to: (1) the blower and fan, (2) the High-Voltage Power Supply, and (3) to a number of transformers for generation of filament, bias, screen, and plate potentials. Power application is accomplished in an automatic sequence that does not require operation, except for depressing two switches. Power removal is also performed in an automatic sequence that may be initiated by the detection of faults, overloads, or by operator control. Time-delay relays used in the various control circuits have adjustable delays which are set by a thumbwheel on the front of each relay. Refer to figures 4-10 and 9-1 for the following discussion.

4-99. TRANSMITTER TURN ON. Depressing FILAMENT ON pushbutton switch 1A11A1S1 closes a set of contacts which applies 110 Vac to the coil of relay 1A1K1, causing the relay to energize. When LOCAL/REMOTE switch 1A1S1 is in LOCAL, relay 1A1K1 will self-latch through one set of internal contacts. In the REMOTE position, a continuous contact is required between terminal points 15 and 16 on terminal board 1TB1 to energize relay 1A1K1. When the LOCAL/REMOTE switch is in the LOCAL position and FILAMENT OFF pushbutton switch 1A11A1S2 is depressed, coil voltage is removed from relay 1A1K1, causing the relay to deenergize and open the self-latching contact. In the

REMOTE position, the connection at terminal points 15 and 16 on terminal board 1TB1, through remote control equipment, is opened to turn the filaments off.

4-100. A second set of normally open, delay off, contacts of relay 1A1K1 energizes relay 1A1K2 and applied three-phase primary power to Blower 1B1 and Fan 2B1. The delay off contacts hold relay 1A1K1 closed for approximately three minutes after coil voltage is removed. This allows the blower to run down and the filament seals to cool. A third set of normally open contacts applies voltage to relay 1A1K3 through the circuit breaker and the air and temperature interlock switches. Three normally open contacts of relay 1A1K3 furnish power to all filament transformers through step/start resistors 1A1R1 and 1A1R2. Relay 1A1K4 is energized after a five-second delay by a fourth delay-on contact on relay 1A1K3. Three contacts on relay 1A1K4 bypass step-start resistors 1A1R2 and 1A1R3, applying full voltage to the filaments. A set of normally open contacts of time-delay relay 1A1TD1 close across the delay contacts of relay 1A1K3 and remain closed for at least two seconds after relay 1A1K3 is deenergized. Time-delay relay 1A1TD1 bypasses the five-second delay contacts of relay 1A1K3 and the five-second filament step/start cycle during momentary power failures, allowing the transmitter to deenergize without delay.

4-101. A fourth contact of relay 1A1K4 applies control voltage to the high-voltage turn-on circuit through the safety interlock circuit which includes all door, ground stick, and external interlocks. The high voltage can now be applied by depressing HIGH VOLTAGE ON pushbutton switch 1A11A1S6. With all safety interlocks closed, depressing the HIGH VOLTAGE ON pushbutton switch energizes relay 1A1K5 which self-latches through one of its normally open contacts, depressing AUTO ON pushbutton switch energizes latching relay 1A1K6, causing on of its normally open contacts to bypass the FILAMENT ON self-latching contacts of relay 1A1K5. A third normally open set of contacts on relay 1A1K6, activates the AUTO ON indicator (1A11A1DS3) circuit and with relay 1A1K6 latched in the AUTO-ON position, the transmitter will automatically reenergize after a power failure or overload. Relay 1A1K6 may be deenergized by depressing FILAMENT OFF pushbutton switch 1A11A1S2 or by energizing the coil of relay 1A1K8.

4-102. Relay 1A1K8 is energized by either depressing the HIGH VOLTAGE OFF pushbutton switch or by the recycle counting circuit on the Fault and Overload Assembly, or by closing of thermal switches 3S1 or 3S2 on the high-voltage Step-Start assembly. A second set of normally open contacts of relay 1A1K5 allows the Modulator Screen and Driver Power Supply and the Bias Power Supply to turn on. This same set of contacts also completes the circuit for Isolated Enclosure solenoid 1L7 through Isolated Enclosure disable switch 1A1S2. Solenoid 1L7 causes the contacts of switch S2, in the Isolated Enclosure, to close and activate the RF Driver and Power Amplifier Screen and Bias Supplies.

4-103. High-Voltage Step/Start Relay 3K1 is energized through High-Voltage Disable switch 1A1S3 and magnetic overload units, relays 3K3, K4, and K5. After approximately one second, a set of normally open contacts on relay 1A1K5 close and energize main high-voltage contactor relay 3K2 through overload relay 1A1K11 and one set of normally open contacts on relay 3K1.

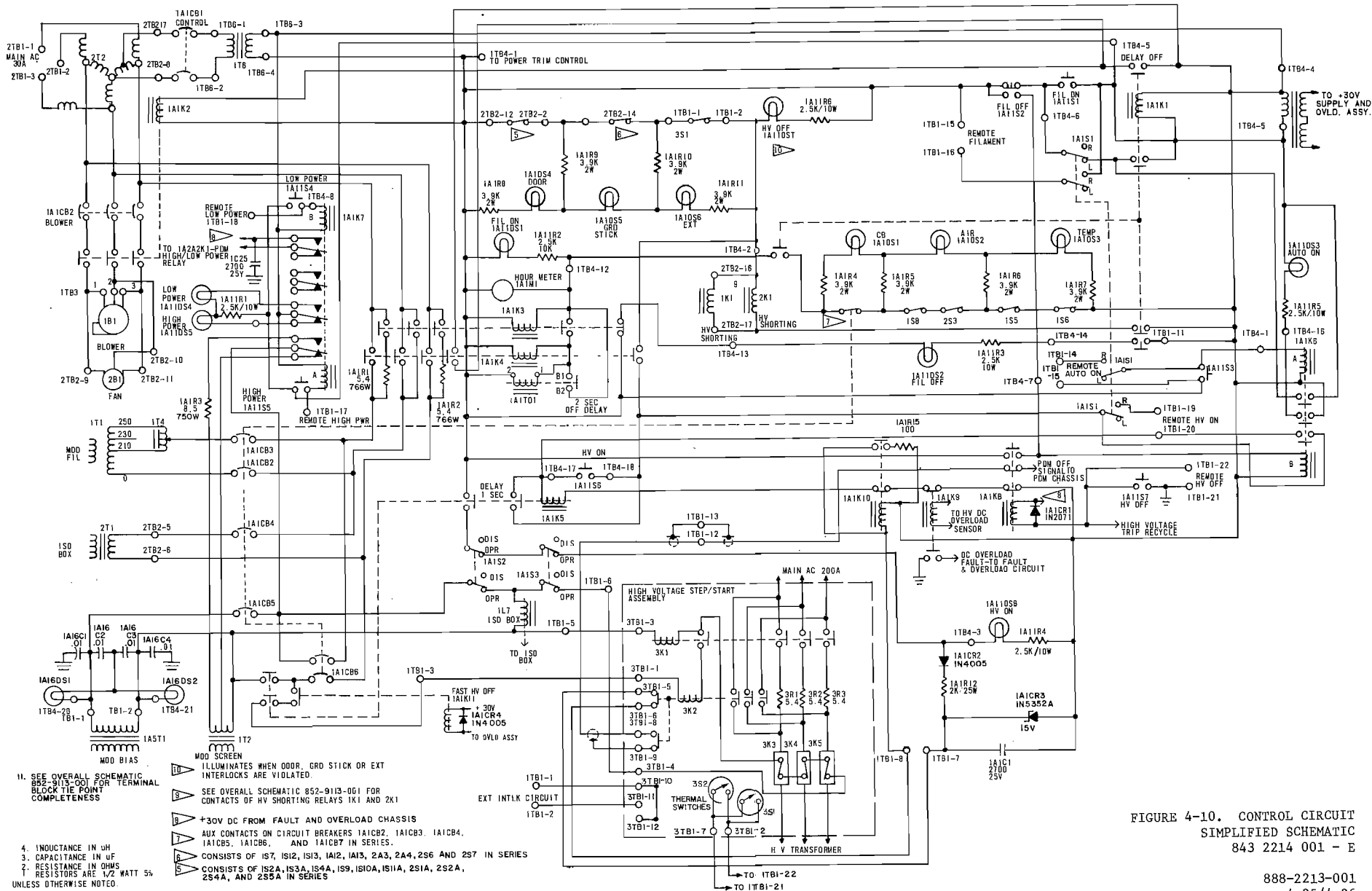

- 1. SEE OVERALL SCHEMATIC 852-913-001 FOR TERMINAL BLOCK TIE POINT COMPLETENESS
 - 2. RESISTANCE IN OHMS
 - 3. INDUCTANCE IN μ H
 - 4. CAPACITANCE IN μ F
 - 5. RESISTORS ARE 1/2 WATT 5% UNLESS OTHERWISE NOTED.
- ▶ ILLUMINATES WHEN OODR, GRD STICK OR EXT INTERLOCKS ARE VIOLATED.
 - ▶ SEE OVERALL SCHEMATIC 852-913-001 FOR CONTACTS OF HV SHORTING RELAYS 1X1 AND 2X1
 - ▶ +30V DC FROM FAULT AND OVERLOAD CHASSIS
 - ▶ AUX CONTACTS ON CIRCUIT BREAKERS 1A1CB2, 1A1CB3, 1A1CB4, 1A1CB5, 1A1CB6, AND 1A1CB7 IN SERIES.
 - ▶ CONSISTS OF 1S7, 1S12, 1S13, 1A12, 1A13, 2A3, 2A4, 2S6 AND 2S7 IN SERIES
 - ▶ CONSISTS OF 1S2A, 1S3A, 1S4A, 1S9, 1S10A, 1S11A, 2S1A, 2S2A, 2S4A, AND 2S5A IN SERIES

FIGURE 4-10. CONTROL CIRCUIT SIMPLIFIED SCHEMATIC 843 2214 001 - E

4-104. A fourth set of normally open delay-on contacts of relay 1A1K5 applies voltage to the Fail-Safe circuit through isolated enclosure disable switch 1A1S2 and high-voltage disable switch 1A1S3. This completes the circuit for high-voltage lamp 1A1A1DS6 and the High-Voltage Fail-Safe Timer circuit consisting of diode 1A1CR2, resistor 1A1R12, diode 1A1CR3, and capacitor 1A1C1. The Fail-Safe circuit will energize relay 1A1K10 through one set of normally closed contacts of relay 3K2 in the event relay 3K2 does not energize, and complete the high-voltage step-start sequence, or is deenergized by magnetic overload relay 3K3, 3K4 or 3K5. A set of normally closed contacts on relay 3K2 opens to allow the PDM to operate at the preset power level.

4-105. TRANSMITTER TURN OFF. Transmitter shutdown is accomplished by depressing HIGH VOLTAGE OFF pushbutton switch 1A1A1S7 which energizes relay 1A1K8. A normally open contact closes which energizes the B coil at mechanical latching relay 1A1K6, disabling the auto-on function. A normally closed contact opens the PDM off circuit, keeping the Modulator on after the high voltage is turned off to discharge the high-voltage capacitors. Depressing FILAMENT OFF pushbutton switch 1A1A1S2 opens the self-latching circuit on relay 1A1K1 causing the relay to deenergize and remove filament voltage. The normally open delay-off contact on relay 1A1K1 remains closed for approximately three minutes after deenergizing relay 1A1K1, which holds the blower contactor relay 1A1K2 energized to allow a period of operation for cooling and blower run-down.

4-106. HIGH-VOLTAGE TIME-DELAY TRIP CIRCUIT. This circuit consists of diode 1A1CR2, resistor 1A1R12, diode 1A1CR3, capacitor 1A1C1, relay 1A1K10, and a normally closed contact on relay 3K2. When relay 1A1K5 energizes, ac voltage is applied to diode 1A1CR2 and capacitor 1A1C1 begins charging through diode 1A1CR2 and resistor 1A1R12. Relay 1A1K10 is connected across capacitor 1A1C1 through a normally closed contact on relay 3K2, if relay 3K2 is not energized. When relay 3K2 energizes, completing the high-voltage step-start sequence, the contact on relay 3K2 opens so that relay 1A1K10 cannot energize. If the high-voltage step-start sequence is not completed (relay 3K2 does not energize) within a time period determined by resistor 1A1R12 and capacitor 1A1C1, relay 1A1K10 energizes. A normally closed contact on relay 1A1K10 (which is in series with contacts on high-voltage relay 1A1K8 and dc overload relay 1A1K9) opens and relay 1A1K5 deenergizes, turning off the high-voltage supply. A second normally open contact on relay 1A1K5 closes, discharging capacitor 1A1C1 through 100-ohm resistor 1A1R15. Should a magnetic overload relay (relays 3K2, 3K4, or 3K5) trip, high-voltage step-start relays 3K1 and 3K2 both deenergize, immediately removing primary power to the high-voltage power supply. A normally closed contact on relay 3K2 also closes and energizes relay 1A1K10, which turns the high voltage circuits off.

4-107. AUTOMATIC RETURN AFTER POWER FAILURE. Depressing AUTO ON pushbutton switch 1A1A1S3 causes latching relay 1A1K6 to keep filament and high-voltage circuits closed in the event of a primary power interruption. Filaments and high voltage will automatically recycle when power is again applied. If the power outage is less than two seconds, filament time-delay 1A1TD1 will allow immediate return to air without step/start filaments.

4-108. Should a major high-voltage fault cause relay 1A1K8 to energize, the automatic return circuit will be disabled and the transmitter will shut off. If dc overloads or repeated faults occur, the automatic return circuit will attempt to restore the transmitter to the air until stopped by the operator or by the Fault and Overload Assembly recycle fault-monitor circuit.

4-109. POWER CHANGE HIGH/LOW. Power output can be changed by depressing either POWER HIGH pushbutton switch 1A11A1S5 or POWER LOW pushbutton switch 1A11A1S4. This causes relay 1A1K7 to latch in the corresponding position.

4-110. Power High. The sequence for high-power operation follows:

- a. Latching of relay 1A1K7 to the A mode removes voltage from the coil of relay 1A2A2K1 inside the PDM chassis to raise the PDM output and audio level.
- b. One contact of relay 1A1K7 applies full voltage to the modulator screen supply.
- c. One contact of relay 1A1K7 energizes POWER HIGH Indicator 1A11-DS5.

4-111. Power Low. Rf carrier is not removed from the air during a high-power to low-power output change. The sequence for low-power operation follows:

- a. The latching relay 1A1K7 in the B mode, applies voltage to relay 1A2A2K1 inside the PDM chassis to lower the PDM output and audio level.
- b. Another contact of relay 1A1K7 closes to connect resistor 1A1R3 in series with the modulator screen power supply transformer primary. This reduces the voltage on both the audio driver drain and the modulator screen to allow low-power distortion adjustment.
- c. One contact of relay 1A1K7 energizes POWER LOW indicator 1A11A1-DS4.

4-112. INTERLOCKS AND SAFETY SWITCHES. When a safety interlock is opened, all voltages above that of the ac input mains are removed and normally open high-voltage shorting switches, relay 1K1 and 2K1, close. The HIGH VOLTAGE OFF pushbutton switch will illuminate whenever a DOOR, GND STICK or EXTERNAL SAFETY interlock is violated. The FILAMENT OFF pushbutton switch will illuminate whenever a BREAKER, AIR flow, or internal air TEMP MALFUNCTION interlock is violated.

4-113. STEP/START ASSEMBLY. The high-voltage step/start assembly contains the ac contactor and the ac overload switch which are required to operate the high-voltage power supply. Operation of this assembly is explained in paragraph 4-103. Excessive overall temperature of the step-start resistors does not illuminate any lamps, but does prevent the transmitter from restarting.

4-114. FAULT AND OVERLOAD CIRCUITS

4-115. FAULT AND OVERLOAD ASSEMBLY 1A3. Fault and Overload Assembly 1A3 contains printed-circuit board A1 which receives fault information from the various overload sensors and causes the transmitter to recycle or completely shutdown. The Fault and Overload Assembly operates from a 30-volt dc power supply. Low-voltage ac from transformer 1T5 is applied to plug J1-23 and plug J1-24 on board A1. The ac is rectified by a bridge rectifier consisting of diodes CR1, CR2, CR3, and CR4. Filtering is accomplished with capacitor 1C25 which is external to board A1. Refer to figure 9-7.

4-116. Power Amplifier Arc. Should an external arc develop between the plate and screen of the PA, arc gap E1 inside the Isolated enclosure, will flash-over and send a transient current through coil L7. This transient is sensed and rectified by PA Arc Sensor 1A15 which turns on SCR diode 1A15CR1. This places a ground on plug J1-16 on board A1 of the Fault and Overload Assembly. This ground is placed through a normally closed set of contacts on relay K1 to diode CR7. Diode CR7 gates a ground to plug J1-24 on board A1 to relay 1A1K11 causing high-voltage Step/Start Assembly to recycle. Ground is also applied to the junction of resistor R68 and diode CR36, causing latching reed relay K9 to energize, closing its normally open contact and illuminating PA ARC Indicator 1A3DS6. The ground at the junction of resistor R68 and diode CR36 is also gated through diode CR36 to the junction of diodes CR11 and CR14 and relay K2. The ground at diode CR11 is gated to the PDM chassis, inhibiting the 75 kHz pulses, which in turn, cuts off Modulator Tube 1V1, and PA tube 1A9V2. The ground at diode CR14 is gated to the base of transistor Q1, causing it to conduct, which in turn, charges capacitor C3 to the supply voltage of 30 volts and turns on transistor Q2 through resistor R11. The collector of transistor Q2 drops to approximately one volt, causing the high/low power relay on the PDM chassis to energize and switch the transmitter to low power. Transistor Q2 conducts for approximately 5 to 10 seconds after transistor Q1 cuts off, the turn-on charge of capacitor C3 having been depleted. The ground at relay K2 causes it to energize, closing its normally open contact, which transfers the charge on capacitor C6 to capacitor C5. After three-to-five recycles in a row, capacitor C5 will have charged up to a voltage higher than the zener voltage of diode CR17, causing transistor Q3 to conduct, placing its collector at approximately one volt. This one-volt level goes through resistor R18 and diode CR16 to plug J2-20 and onto and energizes relay 1A1K8, which removes the high voltage to the transmitter.

4-117. When relay K1 is energized, the normally closed contacts open, stopping current flow to SCR diode 1A15CR1 allowing it to reset.

4-118. DC OVERLOAD. If the high-voltage supply current goes above the threshold determined by resistor 1R10, relay 1A1K9 is energized and closes one set of normally open contacts to place a ground at plug J1-5 on Fault and Overload Assembly board A1. The same sequence of operation for the PA arc occur as described in paragraph 4-115, the DC indicator illuminates and relays K2 or K7 (or both) is energized.

4-119. MODULATOR SCREEN OVERLOAD. If the modulator screen current goes above the value set by resistor 1R14, relay 1K2 is energized and places a ground on plug J1-9 of Overload Assembly board A1. This overload functions similar to the dc overload except the MOD SCREEN overload indicator illuminates and relays K2 or K6 (or both) is energized.

4-120. OUTPUT ARC. Plus 100 Vdc from the modulator screen supply is applied to plug J1-13 on Fault and Overload Assembly board A1. This voltage goes through resistor R6 and relay K3 to plug J1-17 and is then applied to choke 2L6 in the output network of the transmitter. If an arc occurs to ground in the output network of the transmitter, the 100 volts are shorted to ground through the arc, causing relay K3 on board A1 to energize. The normally open contact of relay K3 closes, placing a ground at the junction of resistor R64 and diode CR24 on Fault and Overload Assembly board A1. This overload operates identically to the dc and MOD SCREEN overloads to cause the PDM to recycle. The OUTPUT ARC indicator is illuminated by relay K5.

4-121. VSWR OVERLOAD. If the reflected power at the output goes above the value set at Directional Coupler 2A1, a ground is placed on plug J1-3 on Fault and Overload Assembly board A1, causing relay K8 to energize. The VSWR indicator illuminates.

4-122. The ground on plug J1-3 is gated through diode CR42 to plug J1-13 (PDM off). A VSWR trip turns off the PDM and interrupts the carrier momentarily. The supply voltage remains on and the transmitter will be stepped down to low power before returning to high power after each VSWR trip. The VSWR trip will be counted by the recycle circuit and after three trips the high voltage will be recycled (refer to paragraph 4-127).

NOTE

At the customers option, diode 1CR33 on Fault and Overload board A1 may be removed. The supply voltage will remain on and the VSWR trip is not counted by the recycle circuit. Therefore, the transmitter is not stepped down to low power when it resumes operation.

4-123. Resonator Arc. Photocell 1PV1 looks at the arc gap across the 3rd Harmonic PA plate efficiency resonator through an opaque tube of insulation material. Plus 30 volts is applied to photocell 1PV1 from plug J2-12. If the resonator gap fires, the light from the arc will lower its resistance, turning on Darlington Pair Transistor Q5 which grounds the junction of resistor R69 and diode CR39, latches Fault Board 1A3A1 latching fault relay K10, and removes high voltage from the power amplifier stage by applying a PDM off signal through gating diodes CR39 and CR11, thus extinguishing the arc. Potentiometer R72 sets the trip level of the light sensor.

4-124. ARC GAP. A transient in the 75 kHz low-pass filter network consisting of coil 1L5, capacitor 1C3, and coil 1L4 causes one of the bias spark gaps, 1E1, 1E2, or 1E3, to fire through resistors 1R50, 1R52, and 1R54. This

causes a positive voltage to develop across resistor 1R54 and be present at plug J1-35 on board A1. The positive voltages cause relay K4, on board A1, to energize and close the normally open contact supplying voltage to the arc gap indicator. This same positive voltage also causes transistor Q4, on board A1, to conduct, placing a ground at plug J1-24 and energizing relay 1A1K11, causing the high voltage to recycle.

4-125. REMOTE PLATE VOLTAGE SAMPLE. The plate voltage is the difference between the supply voltage and the voltage of the Isolated enclosure and must be referenced to ground to operate a remote voltmeter. This is accomplished by operational amplifier integrated circuit U1 on board A1. A voltage proportional to the high-voltage power supply, approximately 10 volts, is routed through plug J1-21 on board A1, to pin 10 of operational amplifier integrated circuit U1. A voltage proportional to the Isolated Enclosure voltage, approximately 6 volts at 50kW output, is fed through plug J1-23 on board A1, to pin 3 of operational amplifier integrated circuit U1. Amplifier integrated circuit U1 translates this difference to ground at pin 14 and routes the voltage, through isolation resistor R20 and plug J1-22 to pin 24 on terminal board 1TB1.

4-126. Recycle Circuit. Whenever any overload sensor, except for VSWR trip as already explained (NOTE on page 4-30), places a ground at the junction of diodes 1CR11 and 1CR14 of Fault board 1A3A1, the ground is diode gated to turn the PDM circuit off and to operate relay K2 of Overload board 1A3A1. If recycle switch S2 is on, each time relay K2 energizes the charge on capacitor C6 is applied to capacitor C5. If there are 3 or 4 overloads in quick succession, the voltage on capacitor C5 will reach the conduction point of Zener diode CR17. This will cause transistor Q3 to conduct, and this will close relay 1A1K8. This turns off the high voltage and defeats the automatic return after power failure.

NOTE

The high voltage must be restored with a manual command.

4-127. Resistor R15, shunted across capacitor C5, gives the trigger circuit about a 30-second time constant. This allows the transmitter to recycle about twice each 30 seconds without tripping the high voltage off. Should the fault remain, causing relay K2 to stay closed, resistor R14 will charge capacitor C5 in less than one second turning off the PDM and shutting off the high voltage. If recycle switch S2 is off, i.e. contacts are closed, capacitor C5 is immediately charged through resistor R13 causing the high voltage to be turned off without delay.

4-128. METERING CIRCUITS

4-129. There are ten meters on the MW-50C3 Transmitter front panels. These meters monitor pertinent circuit parameters during tune-up and normal operation and aid in fault analysis of the equipment. Most of the meter circuits are simple and require no explanation. In general, these meters are mounted on metal panels and are placed in low-voltage circuits which offer little

personnel hazard. Meters in the area of the Isolated Enclosure are mounted on a chassis behind a window that makes unintentional physical contact with the meters impossible.

4-130. SUPPLY CURRENT METER 1M5. This meter is a 0 to 5 ampere dc ammeter. It is connected between the negative terminal of the high-voltage supply and ground to measure the total supply current. Carbon block 1E5 protects the meter from excessive voltage. If the voltage at the negative terminal of the meter exceeds 600 volts, as if the power supply positive output is shorted to ground, the carbon block will arc over to ground to protect the meter.

4-131. POWER METER 1M3. This meter indicates the Transmitter RF Output to the Antenna. It is connected to Directional Coupler 2A1 via coaxial cable. The meter has a 100 microampere dc movement and is calibrated from 0 to 100kW full scale.

4-132. POWER AMPLIFIER SCREEN CURRENT METER 1A9M4. This meter measures the total current from 0 to 3 amperes furnished by the power amplifier screen power supply. As this supply also furnishes current for the PA grid circuit, the POWER AMPLIFIER SCREEN CURRENT meter indication includes the sum of the PA screen and PA grid currents.

4-133. POWER AMPLIFIER PLATE CURRENT METER 1A9M2. This meter is connected between the PA filament transformer center tap and the high voltage power supply ground return circuit to indicate PA plate current from 0 to 8 amperes dc.

4-134. PLATE VOLTS METER 1M6. This meter monitors the voltage between the plate and cathode of the PA stage. It has a sensitivity of 1 milliampere full scale and is calibrated from 0 to 12kV. The meter is mounted in a panel which is at ground potential and the movement is connected to Isolated Enclosure 1A7 through 20.02 megohms of series resistance consisting of resistors 1R2 through 1R5 and 1A11R7, refer to figure 4-11. Meter Zero potentiometer 1R7 is used to zero the meter.

4-135. SUPPLY VOLTS METER 1M4. This meter monitors the high-voltage supply output. It has a sensitivity of 1 milliampere full scale and is calibrated from 0 to 30kV. It is connected to the high-voltage power supply through 30 megohms of series resistance consisting of resistors 2R1 through 2R6 (refer to figure 4-11).

4-136. The PLATE VOLTS Meter and SUPPLY VOLTS Meter are connected in a bridge circuit as shown figure 4-11. The PLATE VOLTS Meter indicates voltage dropped across the PA tube and the SUPPLY VOLTS Meter indicates voltage applied to the PA-Modulator series chain. The PLATE VOLTS Meter will always indicate approximately half of the supply voltage depending on the PA duty cycle, 20 percent PA duty cycle will produce 50kW output. The voltage on the PLATE VOLTS and SUPPLY VOLTS meters could reach the same potential only if the PA tube shorts internally or is turned on 100 percent, 250kW carrier power.

4-137. POWER SUPPLIES

4-138. HIGH-VOLTAGE POWER SUPPLY. The high-voltage power supply provides the power amplifier plate operating voltage. It consists of a three-phase delta input 12-phase dual-delta output transformer and a solid state bridge rectifier with transient protection resistors and capacitors. Taps are provided so the voltage output can be adjusted to account for various line conditions and provides approximately 25kV at 4 amperes. The ripple component of the output voltage is inherently low and does not require the usual filter choke. Instead, a low-impedance filter circuit comprised of capacitors 1C12, 2C12, 2C13 and 2C14 provides all required filtering. The ac contactors and ac overloads required to operate the high-voltage power supply, are contained in the High-Voltage Step/Start Assembly.

4-139. PA SCREEN POWER SUPPLY. This power supply is located in Isolated Enclosure 1A9. It consists of full wave bridge rectifier 1A9CR5 (refer to figure 9-4) and associated filters. The power supply operates from a secondary winding of transformer T4 and provides approximately 900 Vdc at 2.5 amperes. The ac input to rectifier 1A9CR5 is controlled by contactor 1A9K1. The ac input path is completed only when bias voltage is available at the power amplifier. Thus, if the bias supply fails, PA screen voltage is removed. In addition, the ac input is interrupted whenever excessive screen current is detected.

4-140. PA BIAS POWER SUPPLY. This power supply (refer to figure 9-2, Assembly 1A9A2 Metering and Bias) consists of a voltage doubler comprised of rectifiers 1A9A2CR1 through 1A9A2CR4 and filter capacitors 1A9C21 and 1A9C22. The supply operates from a secondary winding of transformer 2T1 to provide -600 Vdc at 2 amperes. The -600 Vdc is routed to the grid of the power amplifier and rf driver. The supply is also connected to the cathode of the RF Driver in series with the PA screen supply to provide a plate operating potential of approximately 1500 Vdc for the rf driver.

4-141. The PA bias power supply also provides the voltage to operate screen supply input contactor 1A9K1. No PA screen voltage is generated unless bias voltage is available.

4-142. MODULATOR SCREEN AND DRIVER POWER SUPPLY. This power supply (refer to figure 9-2) provides a nominal 800 Vdc source for the modulator screen grid and audio driver drain. The PDM chassis operating potential of 100 Vdc is also obtained from this 800 Vdc output. The supply consists of full wave rectifier 1A4CR1 which operates from a secondary winding of transformer T2. Current available from this power supply is approximately 2.4 amperes.

4-143. MODULATOR BIAS POWER SUPPLY. This power supply (refer to figure 9-2) provides an output of -500 Vdc which is used as bias voltage for the modulator. The actual bias voltages at the grid of the stage is, however, a function of the bias input voltage and the audio drive. The supply consists of the transformer 1A5T1, bridge rectifier 1A5CR1, choke 1A5L1, and capacitors 1A5C2 and 1A5C3.

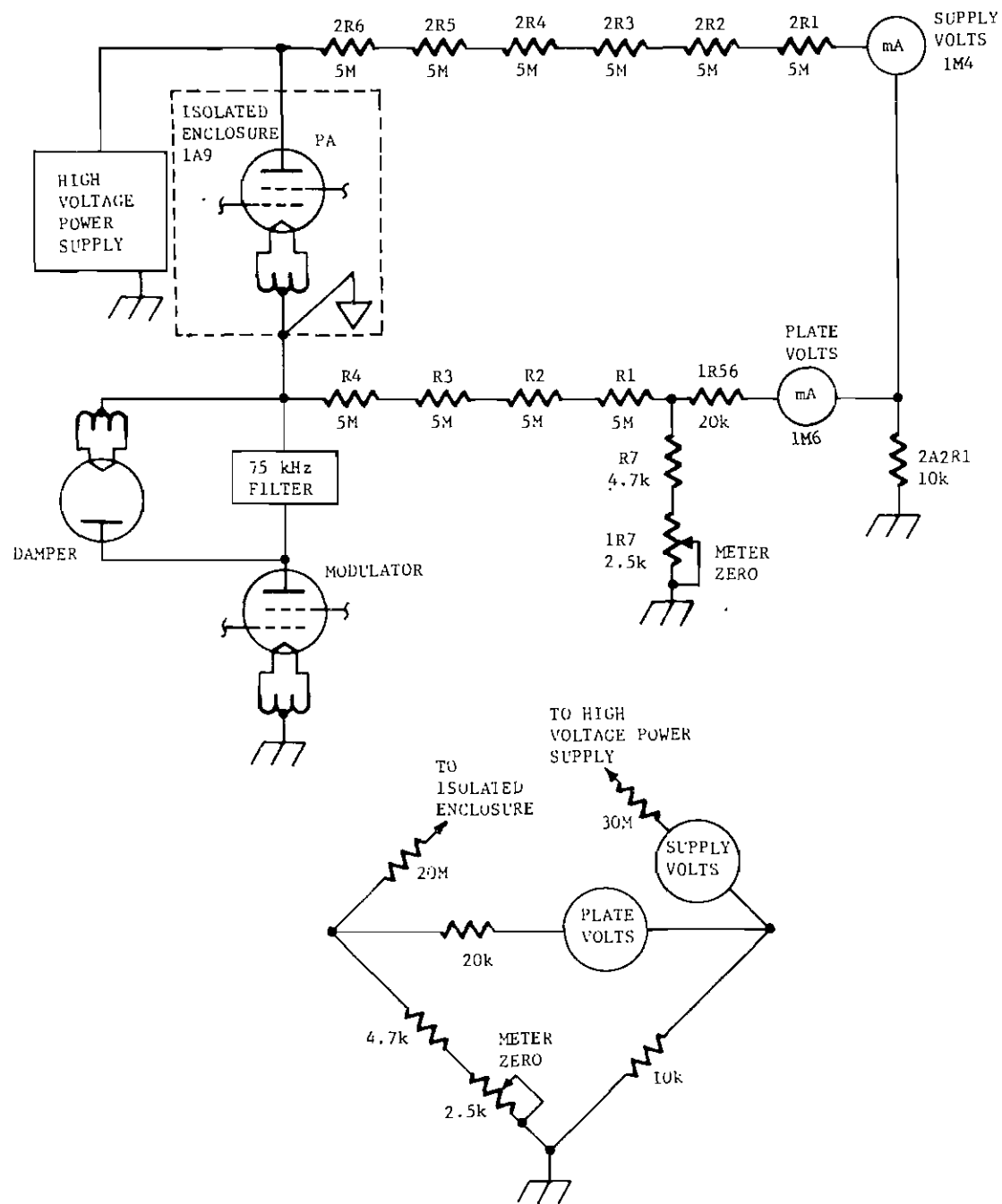

Figure 4-11. High Voltage Metering

4-144. OSCILLATOR/BUFFER POWER SUPPLY. The oscillator power supply (refer to figure 9-5) consists of transformer T1, bridge rectifier CR3, and a choke input filter consisting of coil L3 and capacitor C5. This power supply produces approximately 100 Vdc and establishes two low potentials from this voltage. Zener diode CR2 and resistors R5 and R6 establish a 39-volt potential to operate oscillator output stages transistors Q1 and Q2. Resistor R4 and components on each oscillator board establish a 15 Vdc potential to operate the low-level oscillator stages.

4-145. FAULT AND OVERLOAD ASSEMBLY POWER SUPPLY. Transformer 1T5 (refer to figure 9-1) provides power for the positive 30 Vdc supply contained within the Fault and Overload assembly (refer to figure 9-7). Positive 30 Vdc is produced by a full-wave bridge and filter circuit comprised of diodes 1A3A1CR2 through 1A3A1CR4 and capacitor 1C25.

SECTION V
MAINTENANCE

5-1. INTRODUCTION

5-2. This section provides preventive maintenance checks, cleaning and corrective maintenance information for the HARRIS MW-50C3 MEDIUM WAVE BROADCAST TRANSMITTER.

5-3. PURPOSE

5-4. The information contained in this section is intended to provide guidance to establish a comprehensive maintenance program to promote operational readiness and eliminate downtime. Particular emphasis is placed on preventive maintenance and record keeping functions.

5-5. STATION RECORDS

5-6. The importance of keeping station performance records cannot be over emphasized. Separate logbooks should be maintained by operation and maintenance activities. These records can provide data for predicting potential problem areas and analyzing equipment malfunctions.

5-7. TRANSMITTER LOGBOOK

5-8. As a minimum performance characteristic, the transmitter should be monitored using front panel meters and the results recorded in the transmitter logbook at each shift change or at least once a day.

5-9. MAINTENANCE LOGBOOK

5-10. The maintenance logbook should contain a complete description of all maintenance activities required to keep the transmitter operational. A list of maintenance information to be recorded and analyzed to provide a data base for a failure reporting system is as follows:

DISCREPANCY	Describe the nature of the malfunction. Include all observable symptoms and performance characteristics.
CORRECTIVE ACTION	Describe the repair procedure used to correct the malfunction.
DEFECTIVE PART(S)	List all parts and components replaced or repaired. Include the following details: a. COMPONENT TIME IN USE b. COMPONENT PART NUMBER c. COMPONENT SCHEMATIC NUMBER

	d. COMPONENT ASSEMBLY NUMBER
	e. COMPONENT REFERENCE DESIGNATOR
SYSTEM ELAPSED TIME	Total transmitter time on.
NAME OF REPAIRMAN	Person who actually made the repair.
STATION ENGINEER	Indicates Chief Engineer noted and approved the transmitter repair.

5-11. SAFETY PRECAUTIONS

5-12. It is very dangerous to attempt to make measurements or replace components with power on. The design of the transmitter provides safety features such that when a door is open or a grounding stick is not in its proper place, an interlock switch opens and removes transmitter power. DO NOT SHORT OUT OR BYPASS INTERLOCK SWITCHES.

5-13. Grounding sticks are provided as a safety feature. Each consists of a metal rod with a phenolic plastic handle. The metal end is connected to transmitter ground. USE THE GROUNDING STICK AND TOUCH EVERY PART IN THE AREA OR CIRCUIT ON WHICH MAINTENANCE IS TO BE PERFORMED BEFORE ATTEMPTING MAINTENANCE.

5-14. PREVENTIVE MAINTENANCE

5-15. Preventive maintenance is a systematic series of operations performed periodically on equipment. As these procedures cannot be applied indiscriminately, specific instructions are necessary.

a. Visual Inspection. Inspection is the most important preventive maintenance operation because it determines the necessity for the others. Become thoroughly acquainted with normal operating conditions in order to recognize and identify abnormal conditions readily. The remedy for most visible defects is obvious, however care must be taken if heat damaged components are located. Overheating is usually a symptom of trouble. It is essential to determine the actual cause of overheating before the heat damaged component is replaced, otherwise the damage will be repeated. Inspect for:

1. Overheating, indicated by discoloration, bulging of parts and peculiar odors.
2. Leakage of grease or oil.
3. Oxidation.
4. Dirt, corrosion, rust, mildew and fungus growth.

- b. Feel. Check parts for overheating, especially rotating parts such as blower motors. The need for lubrication, the lack of proper ventilation, or the existence of some defect can be detected and corrected before serious trouble occurs. Become familiar with operating temperatures in order to recognize deviations from the normal range.
- c. Tighten. Tighten loose screws, bolts and nuts. Do not tighten indiscriminately as fittings that are tightened beyond the pressure for which they are designed may be damaged or broken.
- d. Adjust. Make adjustments when inspection shows that adjustments are necessary to maintain normal operation.
- f. Lubricate. Lubricate meshing mechanical surfaces at specified intervals with specified lubricants to prevent mechanical wear and keep the equipment operating normally. Do not over lubricate.
- g. Paint. Paint surfaces with the original type of paint using a prime coat if necessary when inspection shows rust, worn or broken paint film.

5-16. FILTER CLEANING

5-17. Cabinet filters are provided in the transmitter and modulator cabinet air intakes. Clean each filter once a week with replacement done on an as needed basis.

5-18. BLOWER AND FAN MAINTENANCE

5-19. Inspect the blower and fan for dust accumulation monthly. Remove dust with a vacuum cleaner and brush. All blower drives and fan bearings are sealed. Bearings that are noisy or show wear must be replaced. The blower mounting bolts should be checked for tightness. Blower motor current should also be checked occasionally at 1TB3. It should range from 11.5 to 12.2 amperes.

5-20. AIR PRESSURE METER CALIBRATION

5-21. A Dwyer pressure gauge or a Manometer with a range of 0 to 5 inches of water will be needed for the calibration.

5-22. The following is the procedure for the calibration:

WARNING

DISCONNECT AND LOCK OUT STATION PRIMARY
POWER TO THE TRANSMITTER.

- a. Set all transmitters circuit breakers to the OFF position.

- b. Open the right-hand (facing the rear of the transmitter) rear transmitter door exposing the blower compartment.

WARNING

USE GROUNDING STICKS AND GROUND OUT ALL COMPONENTS AND CONNECTIONS BEFORE TOUCHING THEM.

- c. Locate the plastic tee to the right of the air pressure switch.
- d. Disconnect the plastic tube that is routed from the tee to the air pressure switch.
- e. Connect a length of plastic tubing to this tee connection and route the tubing to the outside of the transmitter by wedging the top of the door open enough so as not to pinch the tubing. Connect the other end to a Manometer or a Dwyer pressure gauge.
- f. Close and latch the rear transmitter door.
- g. Zero the meter needle using the adjustment screw accessible through the front panel access hole.
- h. Set the blower and control circuit breakers to the ON position and apply station primary power to the transmitter.
- i. The Manometer/Dwyer pressure gauge indication should be close to 3 inches of water. Compare the Manometer/Dwyer pressure gauge reading to the transmitter air pressure meter reading. If the readings are the same no adjustment of the air pressure meter is necessary. However, if the readings differ an adjustment of the calibration screw will be necessary to match the meter to the Manometer/Dwyer pressure gauge.
- j. If the calibration screw is adjusted, the meter may have to be rezeroed.

SPECIAL NOTE

SOME TRANSMITTERS HAVE A ZERO ADJUSTING HOLE IN THE FRONT PANEL AND SOME DO NOT. METER REMOVAL WILL BE NECESSARY FOR THOSE TRANSMITTERS WITHOUT THE HOLE TO ADJUST THE METER.

- k. For those transmitters without the panel meter zero adjustment access hole, remove the air pressure meter and make the adjustment setup as follows:

WARNING

DISCONNECT AND LOCK OUT STATION PRIMARY
POWER TO THE TRANSMITTER.

1. Open the transmitter left-hand (facing the transmitter) panel.

WARNING

USE GROUNDING STICKS AND GROUND OUT ALL
COMPONENTS AND CONNECTIONS BEFORE TOUCH-
ING THEM.

2. Disconnect the plastic tube from the meter and remove the meter from the panel.
 3. Route the plastic tube through the meter hole in the front panel and reconnect it to the meter.
 4. Support the meter to prevent the plastic tubing from kinking.
 5. Close the front panel.
1. Repeat steps g., h., and i.

WARNING

DISCONNECT AND LOCK OUT STATION PRIMARY
POWER TO THE TRANSMITTER.

- m. Set the blower and control circuit breakers to the OFF position.

WARNING

USE GROUNDING STICKS AND GROUND OUT ALL
COMPONENTS AND CONNECTIONS BEFORE TOUCH-
ING THEM.

- n. Disconnect the test tubing installed in step e. and reconnect the air pressure switch tubing to the tee.

CAUTION

PLASTIC THREADS IN MOUNTING HOLES.

- o. Open the transmitter left-hand (facing the transmitter) panel and reinstall the air pressure meter with the plastic tube connected in the original position.

5-23. HIGH-VOLTAGE POWER SUPPLY. The High-Voltage Power Supply has enclosures to ensure personnel safety. Lethal voltages are exposed when access panels are removed. All servicing of the High-Voltage Power Supply should be carried out in the presence of a safety observer qualified in industrial first-aid. The following safety rules should be followed as minimum guidelines.

WARNING

DO NOT PLACE RELIANCE ON INTERLOCKS, CAPACITOR BLEEDERS OR OTHER BUILT-IN SAFETY DEVICES.

WARNING

DISCONNECT AND LOCK OUT PRIMARY POWER TO THE TRANSMITTER AND POWER SUPPLIES BEFORE STARTING ANY MAINTENANCE ON THE TRANSMITTER. A GROUNDED SHORTING STICK SHOULD BE USED TO SHORT OUT ALL TERMINALS ON ALL POWER SUPPLIES AND ALSO TO TOUCH ALL COMPONENTS BEFORE ANY MAINTENANCE IS STARTED.

- a. Remove cover over connection panel and check all capacitor and power supply terminals for leaking oil and general condition.
- b. Check all connections for tightness.
- c. Dust off high-voltage insulated bushings and terminals.
- d. Replace shorting stick in its holder and replace cover.

5-24. MAINTENANCE OF COMPONENTS

5-25. The following paragraphs provide information for component maintenance.

5-26. TRANSISTORS. Routine checking of transistors used in the MW-50C3 is not required. The best check of transistor performance is actual operation in the transmitter. When transistors are replaced, check circuitry operation which may be affected. Replacement transistors should be of the original type or a recommended direct replacement. Preventive maintenance of transistors is accomplished by performing the following steps:

WARNING

DO NOT TOUCH HEAT SINK AND TRANSISTORS MOUNTED IN HEAT SINKS IMMEDIATELY AFTER REMOVING POWER. BURNS MAY RESULT FROM CONTACT.

- a. Examine all transistors for loose connections or corrosion.
- b. Inspect the transistors and surrounding area for dirt as accumulations of dirt or dust could form leakage paths.
- c. Use a vacuum cleaner to remove dust from the area.

5-27. CAPACITORS. Preventive maintenance of capacitors is accomplished as follows:

- a. Examine all capacitor terminals for loose connections or corrosion.
- b. Ensure that component mountings are tight.
- c. Examine the body of each capacitor for swelling, discoloration, or other evidence of breakdown.
- d. Inspect oil-filled or electrolytic capacitors for leakage signs.
- e. Use standard practices to repair poor solder connections with a low-wattage soldering iron.
- f. Clean cases and bodies of all capacitors.

5-28. VACUUM CAPACITORS. In relation to most types of capacitors, the vacuum capacitor is very expensive. Care in handling and maintenance are prime requisites in order to assure maximum service life. As the vacuum capacitor is evacuated to a higher degree than most vacuum tubes, it is even more susceptible to shock and rough handling. It should never be placed in container with other components without proper packing. During periods of maintenance, the capacitors should be provided with substantial protective coverings. The weakest points of the capacitor are the glass-to-metal seals on each end of the unit. Particular care should be exercised to prevent seal damage during removal or installation.

5-29. Current ratings of vacuum capacitors are limited by the glass-to-metal seal temperature and the temperature of the solder used to hold the capacitor plates. Seal temperature is raised by poor connecting clip pressure, excessive dust and dirt accumulation or excessive currents. The solder temperature is affected by high external temperature and high currents.

5-30. Dust accumulation or sharp points existing in the high-voltage circuitry close to the capacitor can cause arcs or corona which may burn holes through the glass envelope.

5-31. FIXED RESISTORS. Preventive maintenance of fixed resistors is accomplished by the following steps:

- a. When inspecting a chassis, printed-circuit board, or discrete component assembly, examine resistors for dirt or signs of overheating. Discolored, cracked, or chipped components indicate a possible overload.
- b. When replacing a resistor ensure the replacement corresponds to the component designated by the schematic diagram.
- c. Clean dirty resistors with a small brush.

5-32. VARIABLE RESISTORS. Preventive maintenance of variable resistors follows:

- a. Inspect and tighten all loose mountings, connections and control knob setscrews. Do not disturb knob alignments.
- b. If necessary clean components with a dry brush or cloth.
- c. When dirt is difficult to remove, clean with a cloth moistened with an approved cleaning solvent.

5-33. TRANSFORMERS. Preventive maintenance of transformers is accomplished by performing the following:

- a. Check each transformer soon after power removal for signs of overheating.
- b. Inspect each transformer for dirt, loose mounting brackets and rivets, loose terminal connections and insecure connecting lugs. Dust, dirt or moisture between terminals may cause flash overs. Insulating compound or oil around the base of a transformer indicates overheating or leakage.
- c. Tighten loose mounting lugs, terminals or rivets.
- d. Clean with a dry cloth or one moistened with an approved cleaning solvent.
- e. Clean corroded contacts or connections with crocus cloth.

"f. Replace defective transformer.

5-34. FUSES. Preventive maintenance of fuses is accomplished by the following:

- a. When a fuse blows, determine the cause before installing a replacement.
- b. Inspect fuse caps and mounts for charring and corrosion.
- c. Examine fuse clips for dirt, improper tension and loose connections.
- d. If necessary, tighten fuse clips and connections to the clips. the tension of the fuse clips may be increased by pressing the clip sides closer together.
- e. Dust fuses and clips with a small brush.

5-35. METERS. Preventive maintenance of monitoring meters is accomplished as follows:

- a. Inspect meters for loose, dirty or corroded mountings and connections.
- b. Examine leads for frayed insulation and broken strands.
- c. Check for cracked or broken plastic cases and cover glasses.
- d. Tighten loose mountings or connections. Since meter cases are made of plastic, exercise care to prevent breakage.
- e. Clean meter cases and glass cover with a dry cloth.
- f. Remove dirt from mountings and connections with a stiff brush moistened with an approved cleaning solvent.
- g. Remove corrosion with crocus cloth.

5-36. RELAYS. Replace hermetically sealed relays if defective. Non-hermetically sealed relays are considered normal if:

- a. The relay is mounted securely.
- b. Connecting leads are not frayed and the insulation is not damaged.
- c. Terminal connections are tight and clean.
- d. Moving parts travel freely.
- e. Spring tension is correct.

- f. Contacts are clean, adjusted properly and make good contact.
- g. The coil shows no signs of overheating.

5-37. SWITCHES. Preventive maintenance of switches is accomplished by checking the following:

- a. Inspect switch for defective mechanical action or looseness of mounting and connections.
- b. Examine cases for chips or cracks. Do not disassemble switches.
- c. Inspect accessible contact switches for dirt, corrosion or looseness of mountings or connections.
- d. Check contacts for pitting, corrosion or wear.
- e. Operate the switches to determine if each moves freely and is positive in action. In gang and wafer switches the rotor should make good contact with the stationary member.
- f. Tighten all loose connections and mountings.
- g. Adjust contact tension if required.
- h. Clean any dirty or corroded terminal connection or switch section with crocus cloth.
- i. Replace defective switches.

5-38. INDICATORS AND INDICATOR SWITCHES. Preventive maintenance of indicator lamps and indicator switches is accomplished by checking the following:

- a. Examine indicator sockets for corrosion, loose nuts and condition of rubber grommets.
- b. Examine indicator switch by pulling the plastic cover (indicator assembly) from the case.
- c. Inspect indicator assemblies from broken or cracked covers, loose envelopes, loose mounting screws and loose or dirty connections.
- d. Tighten loose mounting screws and solder loose connections. If connections are dirty or corroded, clean with crocus cloth before soldering.
- e. Clean indicator covers, bases and glass bulb with a dry cloth.
- f. Clean corroded socket contacts and connections with crocus cloth. Low-operating voltages require clean contacts and connections.

5-39. PRINTED-CIRCUIT BOARDS. Preventive maintenance of printed-circuit boards is accomplished by checking the following:

- a. Inspect the printed-circuit boards for cracks or breaks.
- b. Inspect the wiring for open circuits or raised foil.
- c. Check components for breakage or discoloration due to overheating.
- d. Clean off dust and dirt with a clean dry cloth.
- e. Use standard practices to repair solder connections with a low-wattage soldering iron.

5-40. CORRECTIVE MAINTENANCE

5-41. Corrective maintenance for the transmitter is limited by the objective of minimum downtime. Maintainability and care are considerably simplified for operation and maintenance personnel as the transmitter was designed and built with highly reliable and proven elements to minimize downtime. If the need to remove and replace a defective component rises, refer to Section II, Installation. Reverse the sequence of installation to remove the component and reinstall as described.

5-42. OSCILLATOR TEST AND ALIGNMENT

5-43. An ac power cable and dummy load which mates J1 on the oscillator chassis is provided with the transmitter (HARRIS P/N 992 2222 001) to assist bench check and alignment of the oscillator assembly, refer to figure 5-3. Connections to plug J1 pins, 1 and 3, 2 and 4, provide primary power for the oscillator power supply. Capacitor C1 and resistor R1 provide an oscillator load which simulates the rf driver grid circuit.

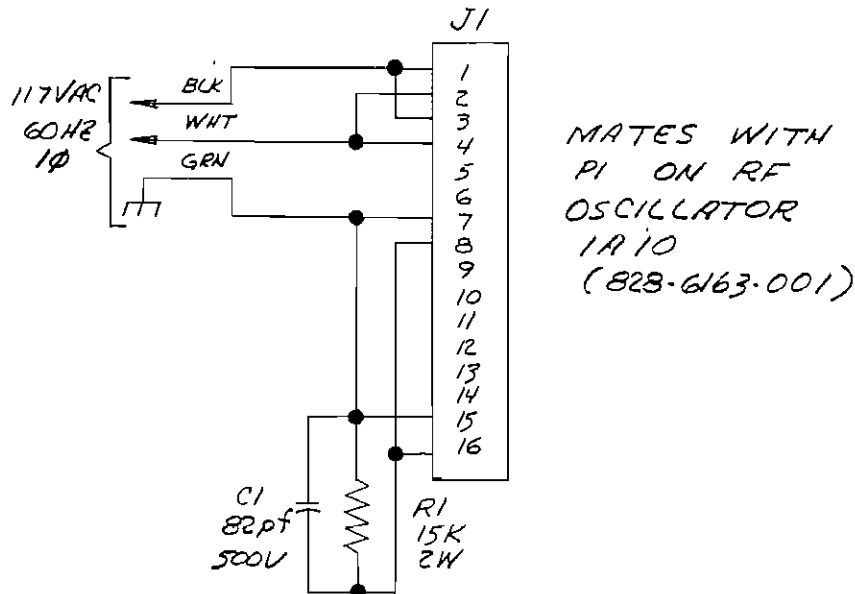

Figure 5-1. Oscillator Unit Bench Test Cable

5-44. PDM FREQUENCY ADJUSTMENT

5-45. The frequency should only be adjusted to compensate for component failure when adequate test equipment is available. The PDM frequency must be adjusted to 75 kHz modulator filter notch. A dip in output noise will be noted as the PDM frequency is tuned through the 75 kHz filter resonance frequency.

5-46. BALL GAP ADJUSTMENT

5-47. The transmitter operates with several arc gaps associated with the high voltage, modulator and damper tubes, Isolated Enclosure and rf output circuits. These gaps are adjusted to operate just above the normal operating potentials so that abnormal voltages will fire the gap. If a transmitter or modulator arc gap is removed for maintenance or is incorrectly positioned, adjust the spacing to the following:

WARNING

DISABLE STATION PRIMARY POWER TO TRANSMITTER. USE GROUNDING STICK TO DISSIPATE POTENTIAL FROM ALL TAPS AND COMPONENTS BEFORE TOUCHING THEM.

<u>SPARK GAP</u>	<u>SPACING</u>
Modulator Screen 1E6	.020 \pm .002 inches
Damper 1E3	.625 \pm .0625 inches
Modulator 1E1	.625 \pm .0625 inches
1E2	.625 \pm .0625 inches
Isolated Enclosure 1E1	.020 \pm .002 inches
1E2	.020 \pm .002 inches
Output 2E2	.030 \pm .002 inches
PA Efficiency Resonator 1E4	.50 \pm .05 inches

5-48. ALIGNMENT/ADJUSTMENT PROCEDURES

5-49. Alignment/adjustment consists primarily of returning or adjusting specific stages in the transmitter after a component has been removed or relaced.

5-50. TEST EQUIPMENT. To properly perform the alignment/adjustment procedures the following test equipment, or equivalent, is required.

<u>NAME</u>	<u>TYPE</u>
Frequency Counter	Hewlett-Packard HP5245L
Oscilloscope	Tektronix 543A
Oscillator, Audio	Data Royal F380A
Signal Generator	Hewlett-Packard HP606

5-51. EFFICIENCY RESONATOR ADJUSTMENT FOR PA PLATE. Perform the 3rd Harmonic resonator adjustment as follows:

WARNING

DISABLE STATION PRIMARY POWER TO TRANSMITTER. USE GROUNDING STICK TO DISSIPATE POTENTIAL FROM ALL TAPS AND COMPONENTS BEFORE TOUCHING THEM.

- Ensure that no power is present at the transmitter.
- Verify components for proper values, tap settings, and tuning control settings.
- Connect test equipment as shown in figure 5-2.

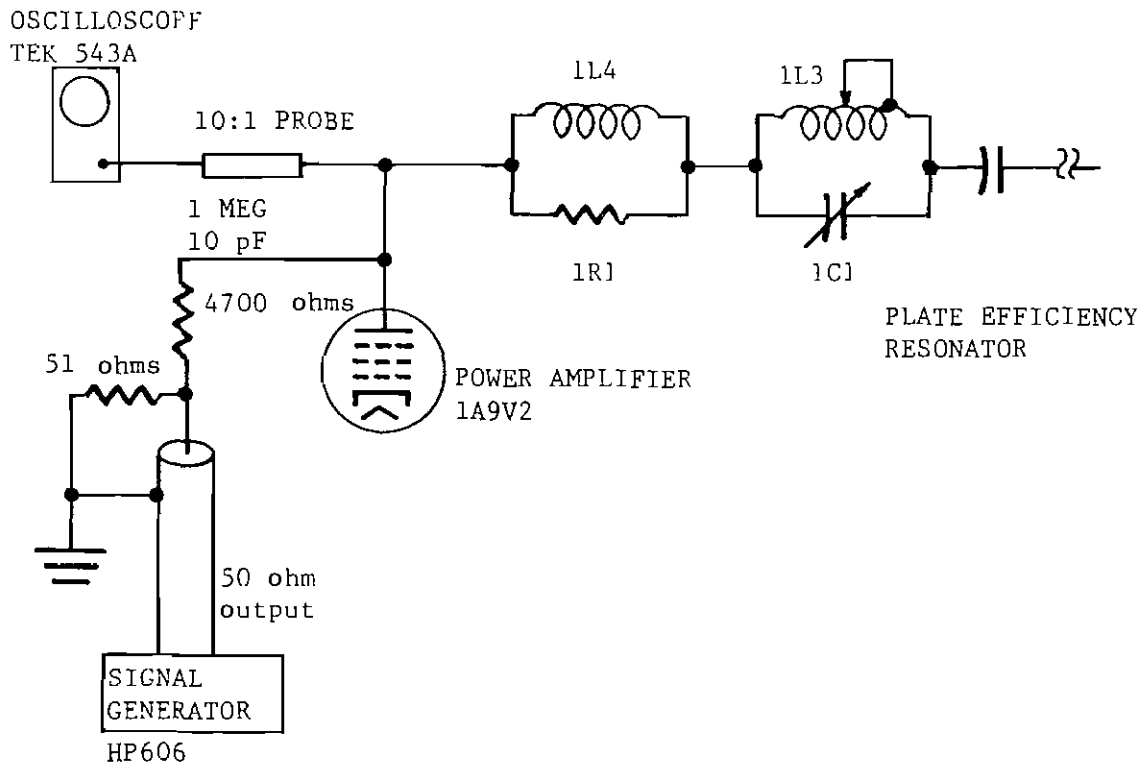

Figure 5-2. Test Setup for Efficiency Resonator Adjustment for PA Plate

- d. Adjust PLATE EFFICIENCY RESONATOR for a dip in PA plate voltage. PA plate voltage should not be allowed to rise more than 200 volts from the dip. If a dip cannot be observed, repeat the procedure in paragraph 5-51 and check P/A output waveform (refer to paragraph 4-60 and figure 4-8).
- e. Set signal generator for 3rd Harmonic frequency output.
- f. Adjust PLATE EFFICIENCY RESONATOR for peak indication on oscilloscope.

NOTE

If the transmitter has been detuned to the extent that efficiency is poor or improper indications are present, perform the above procedure and the Grid Resonator Adjustment.

5-52. RF DRIVER PLATE AND PA GRID EFFICIENCY RESONATOR ADJUSTMENT. Perform the rf driver plate and PA grid efficiency resonator adjustment as follows:

- a. Ensure that no power is present at the transmitter.

WARNING

DISABLE STATION PRIMARY POWER TO TRANSMITTER. USE GROUNDING STICK TO DISSIPATE POTENTIAL FROM ALL TAPS AND COMPONENTS BEFORE TOUCHING THEM.

- b. Connect test equipment as shown in figure 5-3.
- c. Set signal generator for carrier frequency output.
- d. Adjust coil L1 for peak indication on oscilloscope.
- e. Reset signal generator for third harmonic frequency output.
- f. Adjust coil L2 for peak indication on oscilloscope.
- g. Repeat steps c. through f. until a peak at both frequencies is attained.
- h. Remove test setup for transmitter.
- i. Apply primary power, 40-ampere service only, to transmitter.
- j. Set ISO ENCL B+ - OPERATE/DISABLE switch to OPERATE.

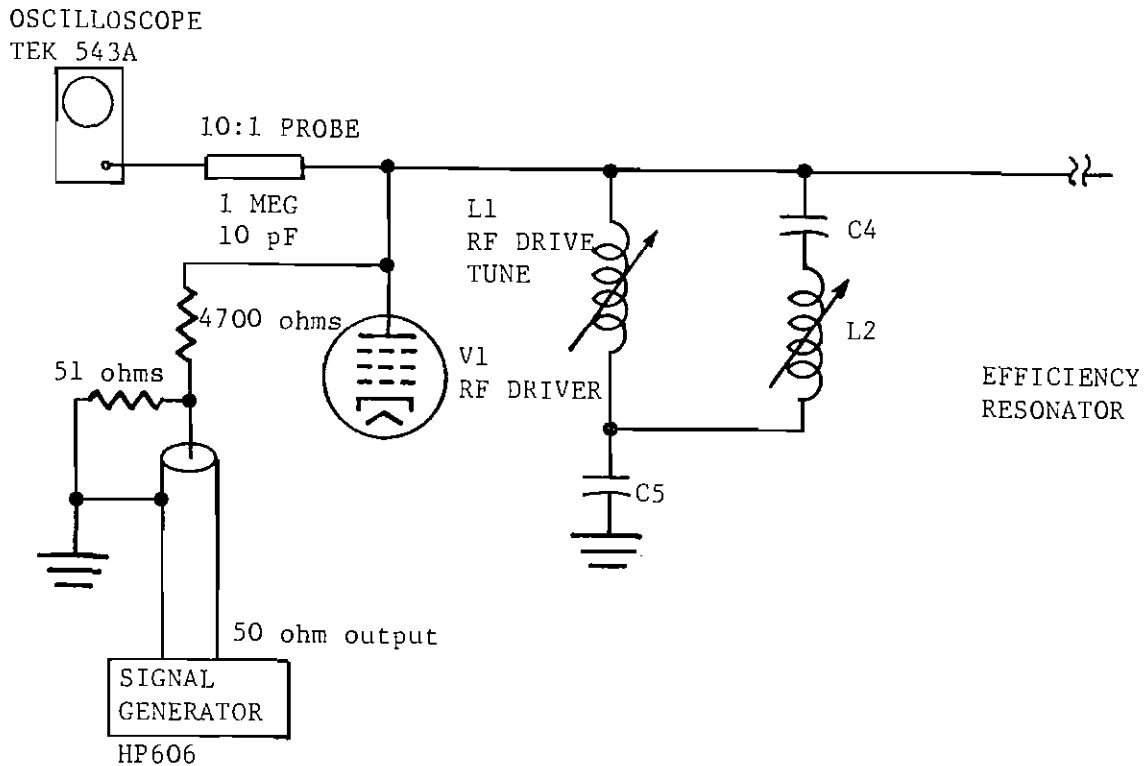

Figure 5-3. Test Setup for RF Driver Plate and PA Grid Efficiency Resonator Adjustment

- k. Depress HIGH VOLTAGE-ON pushbutton switch. Verify that POWER AMPLIFIER SCREEN CURRENT meter indicates less than 2.2 amperes.
- l. Adjust DRIVER PLATE TUNE for maximum indication on POWER AMPLIFIER SCREEN CURRENT meter.

NOTE

In the next step, do not adjust more than 1/2 turn.

- m. Using a blade screwdriver, adjust GRID EFFICIENCY RESONATOR for a small peak indication on the POWER AMPLIFIER SCREEN CURRENT meter.
- n. Adjust PA SCREEN PROTECTOR for 2.4 amperes indication on the POWER amplifier screen current meter.

5-53. DIRECTIONAL COUPLER ADJUSTMENT. Adjust the Directional Coupler as follows:

WARNING

DISABLE STATION PRIMARY POWER TO TRANSMITTER. USE GROUNDING STICK TO DISSIPATE POTENTIAL FROM ALL TAPS AND COMPONENTS BEFORE TOUCHING THEM.

- a. Disconnect trip lead from terminal 2.
- b. Check that test connectors TJ1 and TJ2 are in the horizontal position and TJ3 is in the upper (left) position. Refer to figure 5-4.
- c. Adjust potentiometers 2A1R20 and 2A1R21 maximum clockwise.
- d. Apply power to transmitter.
- e. Depress HIGH VOLTAGE ON pushbutton switch/indicator.
- f. Adjust transmitter for 50kW output as indicated by calibrated dummy load.
- g. Set FORWARD/REFLECTED switch to REFLECTED.
- h. Adjust capacitor 2A1C9 for null indication on POWER meter.
- i. Remove test connectors TJ1 and TJ2 and install in vertical position.
- j. Adjust potentiometer 2A1R20 for same indication (as in step f.) on POWER meter. Do not change 2A1R20 unless transmitter output power is accurately known.
- k. Set REFLECTED/FORWARD switch to FORWARD.
- l. Adjust capacitor 2A1C10 for null indication on POWER meter.
- m. Remove test connectors TJ1 and TJ2 and reinstall in horizontal position.
- n. Adjust potentiometer 2A1R21 for same indication (as in step l.) on POWER meter. Do not change 2A1R21 unless transmitter output power is accurately known.
- o. Remove test connector TJ3 and reinstall it in the lower position.
- p. Operate REFLECTED/FORWARD switch to REFLECTED.

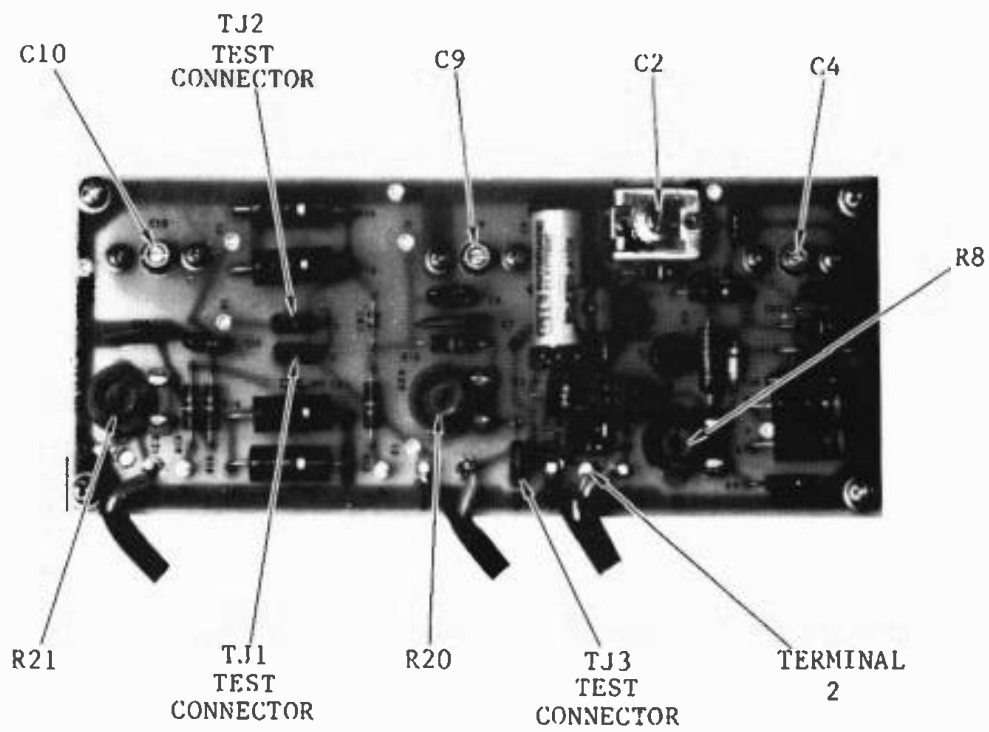

Figure 5-4. Directional Coupler 2A1 Adjustment Locations

- q. Alternately adjust capacitors 2A1C4 and 2A1C2 for an optimum null on POWER meter.
- r. Remove test connector TJ3 and reinstall in original upper position.
- s. Repeat steps g. through o. to ensure proper meter settings and compensation for any interactions that may be present.
- t. Replace the trip lead which was disconnected in step a.
- u. Potentiometer 2A1R9, which is the VSWR Trip Sensitivity Control, is set at the factory to meet pre-shipment test conditions. However, following installation it may be necessary to readjust the control if spurious VSWR trips are noted.

5-54. AUDIO INPUT/PDM CONTROL - FEEDBACK BOARD. Adjust and align the Audio Board as follows:

- a. Adjust the controls as follows prior to starting an alignment/-adjustment procedure. If only minor adjustments are to be made to the Audio Board, the controls do not need to be changed before starting the adjustment procedure.
 1. INPUT GAIN potentiometer R11 fully CCW.
 2. CMRR potentiometer R18 fully CW.
 3. HUM NULL potentiometer R24 fully CCW.
 4. DISS LIMITER potentiometer R34 fully CW.
 5. CARRIER SHIFT potentiometer R36 midrange.
 6. LO POWER AUDIO potentiometer R25 midrange.
 7. MODULATION TRACKING potentiometer R26 midrange.
 8. HI POWER potentiometer R44 fully CCW.
 9. LOW POWER potentiometer R45 fully CCW.
 10. BESSEL FILTER IN/OUT switch set to the OUT position.

5-55. Audio Board Alignment. Ensure board controls are adjusted as outlined in paragraph 5-54. Accomplish the following steps for alignment:

- a. Apply power to the transmitter and depress FILAMENT ON pushbutton switch.
- b. Check for the following voltages:

1. Transistor Q1 emitter, $14.0 \pm 1.0V$.
 2. Transistor Q2 emitter, $-14.0 \pm 1.0V$
- c. Jumper terminals G and H together and drive against ground using a low-distortion oscillator with an output impedance of 600 ohms or less.
 - d. Connect an oscilloscope to pin 8 of integrated circuit U1C.
 - e. Adjust the oscillator output to 0 dBm at 60 Hz and adjust CMRR potentiometer R18 for null. Null depth must be greater than 60 dBm.
 - f. Remove jumper wire from terminals G and H.
 - g. Drive terminals G and H with a balanced sinusoidal signal at 0dBm, 300 Hz and adjust MODULATION TRACKING potentiometer R26 for a null at pin 7 and 9 of integrated circuit U3.
 - h. Energize relay K1 by switching to low power.
 - i. Adjust LO POWER AUDIO potentiometer R25 for a null at pin 7 and 8 of integrated circuit U3.

5-56. Audio Board Adjustment. Ensure board controls are adjusted as outlined in paragraph 5-54. Accomplish the following steps for adjustment:

- a. Complete normal transmitter start-up procedures, with no audio applied.
- b. Depress POWER HIGH pushbutton switch and adjust HI POWER potentiometer R44 CW until normal high operating power is attained.
- c. Depress POWER LOW pushbutton switch and adjust LO POWER potentiometer R45 CW until normal low operating power is attained.
- d. Depress POWER HIGH pushbutton switch to return transmitter to normal high operating power.
- e. Set Modulation Enhancer operate/bypass switch to the bypass position.
- f. Apply +10 dB 300 Hz sinusoidal audio signal to the transmitter input and adjust INPUT GAIN potentiometer R11 for 100 percent modulation.
- g. Alternately remove and apply the +10 dB 300 Hz audio input signal while adjusting CARRIER SHIFT potentiometer R36 for no change in the carrier level, as indicated on the station modulation monitor.

- h. Reduce the +10 dB 300 Hz audio input signal to a 50 percent to 80 percent modulation range as indicated on the station modulation monitor.
- i. Connect a Volt/Ohm meter to pin 10 of integrated circuit U3 and adjust MODULATION TRACKING potentiometer R26 for a 0.0 Vdc indication on the meter.
- j. While monitoring the station modulation monitor, adjust front panel power control from minimum to maximum end of its range. If modulation level changes more than 1 percent for a 20 percent change in power level, adjust MODULATION TRACKING potentiometer R26 CW. Potentiometer R26 will vary absolute modulation levels, therefore it will be necessary to readjust audio input level/-INPUT GAIN potentiometer R11. This will be an iterative process which will require careful, deliberate adjustments.
- k. Apply a +10 dB 300 Hz sinusoidal audio signal to the transmitter input and adjust INPUT GAIN potentiometer R11 for 100 percent modulation.
- l. Depress POWER LOW pushbutton switch and adjust LO POWER AUDIO potentiometer R25 for 100 percent modulation.
- m. With no audio signal applied to the transmitter and plug P1 in jack J1 in any position, adjust HUM NULL potentiometer R24 CW from fully CCW position until a dip in noise measurement is noted. If noise increases or no dip is observed, adjust potentiometer R24 fully CCW and reposition plug P1 to another position in jack J1. Repeat the procedure until a dip in noise measurement is noted. With some transmitters no dip will be noted in any position. In this case leave potentiometer in the full CCW position.

5-57. Bessel Filter Adjustment. The bessel filter as supplied with the Audio Board has a 47k-ohm resistor network which will eliminate overshoot, but "roll-off" the transmitter at 10 kHz. Decreasing network resistance by replacing the 47k-ohm network with 39k-ohm, 33k-ohm, 27k-ohm or 22k-ohm networks, or by inserting fixed, 1/4W, 5 percent resistors of those values directly in the socket will increase the transmitter 3 dB down frequency or will increase the transmitter -3dB frequency. It is possible to reduce overshoot 50 percent, without affecting transmitter frequency response, by using a 27k-ohm resistor network.

5-58. Low-Frequency -3 dB Point Adjustment. With inadequate processing, dc overloads or erratic supply current may present a problem. If carrier shift under modulation is severe, check the output of the processing equipment with a dc coupled oscilloscope. The resulting oscilloscope base line should be steady. If the base line oscillates adjust the station processing equipment. If, however the processing equipment cannot be adjusted to produce a steady base line, capacitor C41 should be replaced with a lesser value to correct the problem.

SECTION VI

TROUBLESHOOTING

6-1. INTRODUCTION

6-2. This section contains troubleshooting for the HARRIS MW-50C3 MEDIUM WAVE AM BROADCAST TRANSMITTER.

6-3. TROUBLESHOOTING

6-4. Most troubleshooting consists of visual checks. Because of high voltages present in the transmitter, it is not safe to work with power on. In the event of problems, isolate the trouble area to the power supply, antenna system, PA section or modulator section with the meters, circuit breakers and indicators for each section.

6-5. Malfunctions in the modulator system may be isolated by comparing the following list to the modulator MULTIMETER indications. Column 1 lists the indications obtained with the high-power level adjust potentiometer R44 set to the maximum clockwise position and column 2 lists indications obtained with potentiometer R44 set to the maximum counterclockwise position. These readings are taken with the 200-ampere high-voltage supply turned off so that supply voltage is not present, and after PLATE ON pushbutton switch/indicator is depressed to energize all other transmitter power supplies.

<u>Modulator MULTIMETER Switch Position</u>	<u>Column 1</u>	<u>Column 2</u>
DRIVER SOURCE AMPS 0-3	1.2	0.750
DRIVER GATE VOLTS 0-30	11.5	5.5
DRIVER DRAIN VOLTS 0-1200	40	200
MOD GRID VOLTS 0-1200	400	0
MOD SCREEN VOLTS 0-1200	860	300
MOD SCREEN AMPS 0-3	1.45	3.0
AUX DRIVER AMPS 0-1.2	0.1	0.1
AUX DRIVER VOLTS 0-120	100	100

6-6. When the trouble has been isolated to a specific area, refer to the theory section of this manual for circuit discussion or schematic diagrams to aid in problem resolution. Table 6-1 lists some typical trouble symptoms, probable causes, and corrective actions pertaining to the overall transmitter. The corrective action given for a trouble symptom is not necessarily the only answer to a problem. It only tends to lead the repairman into the area that may be causing the trouble. In event parts are required refer to Section VII Parts List.

6-7. Prior to starting a troubleshooting procedure check all switches, power cord connections, connecting cables, and power fuses.

6-8. TECHNICAL ASSISTANCE

6-9. HARRIS Technical and Troubleshooting assistance is available from HARRIS Field Service during normal business hours (8:00 AM - 5:00 PM Central Time). Emergency service is available 24 hours a day. Telephone 217/222-8200 to contact the Field Service Department or address correspondence to Field Service Department, HARRIS CORPORATION, Broadcast Transmission Division, P.O. Box 4290, Quincy, Illinois 62305-4290, USA. The HARRIS factory may also be contacted through a TWX facility (910-246-3212) or a TELEX service (247319).

Table 6-1. Fault Isolation Procedures.

TROUBLE SYMPTOM	PROBABLE CAUSE	CORRECTIVE ACTION
<p>Repeated DC overloads with PDM turned up or as transmitter is modulated (high power).</p>	<ol style="list-style-type: none"> 1. No PA Control grid bias. 2. Shorted auxiliary modulator driver transistor. 3. Defective modulator gate control supply potential. 4. Defective modulator driver Mosfet. 5. Defective PDM feedback path. 	<ol style="list-style-type: none"> 1a. Check for absence of PA grid bias. Repair as necessary. 2a. Check auxiliary modulator driver transistor 1A14Q1 for a short. Replace as necessary. 3a. Check for faulty diode 1A2A1CR10 or 1A2CR1. Replace as necessary. 4a. Check modulator driver Mosfet. Replace as necessary. 5a. Check feedback path from PA plate circuit to PDM chassis. Repair as necessary.
<p>Repeated DC overloads with PDM turned down (power control potentiometer 1A2A2R44 fully CCW)</p>	<ol style="list-style-type: none"> 1. No PDM output. 2. Broken or loose PDM cable. 	<ol style="list-style-type: none"> 1a. Check and repair PDM power supply as necessary. 1b. Isolate and replace defective PDM component. 2a. Check cable and repair as necessary. Refer to Section VIII, Wire List for cable wiring.

WARNING: Disconnect primary power prior to servicing.

888-2213-001

6-3

Table 6-1. Fault Isolation Procedures (Continued).

TROUBLE SYMPTOM	PROBABLE CAUSE	CORRECTIVE ACTION
<p>No transmitter rf output. PA PLATE VOLTS goes to full scale.</p>	<p>3. Isolated box or high voltage shorted or arcing to ground.</p>	<p>3a. Remove short. Clean area around isolated box and remove carbon arc path if one has developed.</p>
	<p>4. No modulator screen bias voltage.</p>	<p>4a. Check 1A4 modulator screen and driver supply. Repair as necessary.</p>
	<p>5. Shorted auxiliary modulator driver transistor.</p>	<p>5a. Check for shorted auxiliary modulator driver transistor 1A141Q1. Replace as necessary.</p>
	<p>6. Defective modulator driver Mosfet.</p>	<p>6a. Check modulator driver transistor. Replace as necessary.</p>
	<p>7. Defective PDM feedback path.</p>	<p>7a. Check and repair feedback path from PA plate circuit to PDM chassis as necessary.</p>
	<p>1. No PA screen current.</p>	<p>1a. Check oscillator for output. Repair if defective.</p> <p>1b. Check oscillator power supply. Repair if defective.</p> <p>1c. Check for open rf driver or PA filament. Replace if defective.</p> <p style="text-align: right;">(Continued)</p>

Table 6-1. Fault Isolation Procedures (Continued).

TROUBLE SYMPTOM	PROBABLE CAUSE	CORRECTIVE ACTION
	<p>2. No PA screen voltage.</p>	<p>1d. Check for defective rf driver and PA filament transformer. Replace if defective.</p> <p>1e. Check rf driver circuit for defective plate tuning component. Replace as necessary.</p> <p>1f. Check wiring between isolated enclosure and oscillator assembly for open wiring. Repair as necessary.</p> <p>1g. Check PA screen circuit for open choke 1A9L6 or screen decoupling resistor 1A9R44. Replace if defective.</p> <p>2a. Check PA screen power supply for open choke 1A9L8, transformer 1A9T4 or rectifier 1A9CR5. Replace as necessary.</p> <p>2b. Check relay 1A9K1 for defective contacts. Replace if necessary.</p>

WARNING: Disconnect primary power prior to servicing.

888-2213-001

6-5

Table 6-1. Fault Isolation Procedures (Continued).

TROUBLE SYMPTOM	PROBABLE CAUSE	CORRECTIVE ACTION
Audio distortion at high frequencies.	<ol style="list-style-type: none"> 1. Antenna phasor Q too high. 2. PA mistuned. 3. Grid or plate efficiency resonators mistuned. 4. Incorrect auxiliary modulator driver adjustment. 	<ol style="list-style-type: none"> 1a. Check antenna phasor and adjust if necessary. 2a. Check PA tuning. Retune if necessary. 3a. Check tuning of efficiency resonators. Retune if necessary to in or near plate voltage dip. 4a. Check adjustment of AUXILIARY MODULATOR and AUXILIARY DRIVER. Readjust if necessary.
Audio distortion at all frequencies.	<ol style="list-style-type: none"> 1. PA loaded incorrectly. 2. Auxiliary modulator driver maladjusted. 3. Defective resistor in modulator screen circuit. 4. Excessive modulator screen current. 	<ol style="list-style-type: none"> 1a. Check PA plate loading. Adjust if necessary. 2a. Check adjustment of auxiliary modulator driver. Adjust AUXILIARY DRIVER as necessary. 3a. Check resistors 1R24 and 1R25 in modulator driver. Adjust AUXILIARY DRIVER. 4a. Check modulator screen and driver power supply 1A4. Repair as necessary.

Table 6-1. Fault Isolation Procedures (Continued).

TROUBLE SYMPTOM	PROBABLE CAUSE	CORRECTIVE ACTION
	<p>5. Low PA screen current.</p> <p>6. Shorted Zener diode on dc coupling board 1A7.</p> <p>7. Defective dc regulator diode in PDM output circuit.</p> <p>8. Defective PDM power supply Zener diode.</p>	<p>5a. Check PA screen power supply and associated circuitry. Replace as necessary.</p> <p>6a. Check driver drain voltage and modulator control grid bias voltage. The sum of the two voltages should be approximately 450 Vdc. If not, check for shorted 1A7CR3-CR7 Zener diode on 1A7 dc coupling board. Repair as necessary.</p> <p>7a. Check for shorted or changed value of diode 1A2A1CR10 on PDM board 1A2A1. Replace as necessary.</p> <p>8a. Check for +15 volts at diode 1A2A1CR4 on PDM chassis. Replace as necessary.</p> <p>8b. Check for +100 volts at diode 1A2CR1 on PDM chassis. Replace as necessary.</p> <p>8c. Check for +39 volts at diode 1A2CR2 on PDM chassis. Replace as necessary.</p>

WARNING: Disconnect primary power prior to servicing.

888-2213-001

6-7

Table 6-1. Fault Isolation Procedures (Continued).

TROUBLE SYMPTOM	PROBABLE CAUSE	CORRECTIVE ACTION
<p>Noise on carrier (120 or 60 Hz)</p>	<ol style="list-style-type: none"> 1. Primary ac power line-to-line or voltage-to-phase inbalance. 2. Low PA screen current. 3. PA feedback circuit voltage low. 4. Grid or plate efficiency resonators mistuned. 5. RF in audio lines. 6. Noisy rf driver tube. 	<ol style="list-style-type: none"> 1a. Check primary ac power line-to-line voltage and phase currents. Correct as necessary. 2a. Check rf driver tube 1A9V1. Replace if necessary. 2b. Check rf driver plate and PA screen supply for low voltage. Repair as necessary. 3a. Check PA feedback voltage at terminal N on PDM board 1A2A2 for -10 to -12 Vdc to ground at 55 kW transmitter output power. Repair as necessary. 4a. Check tuning of efficiency resonators. Retune if necessary to in or near plate voltage dip. 5a. Check and repair bypass, filters, and shielding. 6a. Check rf driver tube 1A9V1. Replace as necessary.

Table 6-1. Fault Isolation Procedures (Continued).

TROUBLE SYMPTOM	PROBABLE CAUSE	CORRECTIVE ACTION
<p>AIR MALFUNCTION INTERLOCK indicator illuminates</p>	<p>7. Open modulator filament bypass capacitors.</p>	<p>7a. Check modulator filament bypass capacitors 1A9C3 and 1A9C4. Replace if defective.</p>
		<p>7b. Check modulator filament bypass capacitors 1C7 and 1C8. Replace if necessary.</p>
	<p>8. Open filter in low-voltage power supplies.</p>	<p>8a. Check ripple voltage on low-voltage power supplies. Repair as necessary.</p>
	<p>9. Bad capacitor in PDM feedback circuit.</p>	<p>9a. Check capacitor 1A2A2C32 on PDM board A2. Replace if defective.</p>
	<p>10. PDM frequency out of filter notch.</p>	<p>10a. Refer to paragraph 5-44. Adjust as necessary.</p>
	<p>1. Main blower current not 11.5 to 12.2 amperes.</p>	<p>1a. Refer to paragraph 5-18 and adjust as necessary.</p>
	<p>2. Transmitter room under negative pressure.</p>	<p>2a. Blower compartment must be under positive pressure. Refer to paragraph 2-9.</p>
	<p>3. Dust in air switch tubes.</p>	<p>3a. Clean air switch tubes if necessary.</p>

Table 6-1. Fault Isolation Procedures (Continued).

TROUBLE SYMPTOM	PROBABLE CAUSE	CORRECTIVE ACTION
	<p>4. Improper exhaust ducting.</p> <p>5. Dirty air filters.</p> <p>6. Dust accumulation on blower impeller.</p> <p>7. Air switch requires adjustment</p>	<p>4a. Ducting for 5000 CFM of air is required. Refer to paragraph 2-9.</p> <p>5a. Clean air filters if necessary.</p> <p>6a. Remove blower impeller and clean as necessary.</p> <p>7a. Adjust air switch. See note after paragraph 2-35-1 on page 2-44.</p>

SECTION VII

PARTS LIST

7-1. INTRODUCTION

7-2. This section provides a description, reference designator and part number for selected replaceable parts and assemblies necessary for proper maintenance of the HARRIS MW-50C3 MEDIUM WAVE AM BROADCAST TRANSMITTER. Table 7-1 lists assemblies having replaceable parts, located. Identity of the assembly nomenclature in table 7-1 signifies the equipment level within the overall equipment configuration.

7-3. REPLACEABLE PARTS SERVICE

7-4. Replacement parts are available 24 hours a day, seven days a week from the HARRIS Service Parts Department. Telephone 217/222-8200 to contact the service parts department or address correspondence to Service Parts Department, HARRIS CORPORATION, Broadcast Transmission Division, P.O. Box 4290, Quincy, Illinois 62305-4290, USA. The HARRIS factory may also be contacted through a TWX facility (910-246-3212) or a TELEX service (247319).

Table 7-1. REPLACEABLE PARTS LIST INDEX

TABLE NO.	UNIT NOMENCLATURE	PART NO.	PAGE
7-2	XMTR, MW50C3 AM 50KW 60HZ	994 8832 004	7-3
7-3	XMTR, BASIC MW50C3	994 8832 006	7-6
7-4	UNIT #1, MOD & PA CUBICLE	992 6311 002	7-7
7-5	CONTROL UNIT 1A1	992 6325 001	7-11
7-6	PWB, RELAY P/O 1A1	992 3769 003	7-12
7-7	PDM UNIT 1A2	992 6327 002	7-13
7-8	PWB, PDM GEN 1A2A1	992 6771 001	7-14
7-9	PWB, AUDIO INPUT 1A2A2	992 5898 001	7-16
7-10	PDM POT KIT-MW5/10/50	992 6692 001	7-18
7-11	PWB, MOD ENHANCER	992 4474 001	7-19
7-12	PWB, INTERFACE 1A2A4	992 6416 002	7-20
7-13	FLAG & OVERLOAD 1A3	992 6323 001	7-21
7-14	FLAG & OVERLOAD 1A3A1	992 6411 001	7-22
7-37	SCREEN PWR SUPPLY 1A4	992 3468 001	7-48
7-15	BIAS PWR SUPPLY 1A5	992 3469 001	7-24
7-16	DC COUPLER 1A7	992 3471 002	7-25
7-17	AUDIO DRIVER 1A8	992 6326 002	7-26
7-18	ISOLATED BOX 1A9	992 6322 002	7-27
7-19	METERING BOARD 1A9A1	992 6408 001	7-29
7-20	METERING & BIAS 1A9A2	992 6409 001	7-30
7-21	METER MULTIPLIER 1A9A4	992 6404 003	7-31
7-38	OSCILLATOR UNIT 1A10	992 6324 001	7-49
7-22	PWB, OSCILLATOR 1A10A1&2	992 2165 002	7-32
7-23	METER PANEL 1A11	992 6321 001	7-33
7-24	SWITCH BOARD 1A11A1	992 6437 001	7-34
7-25	ASSY, GRD SWITCH	929 1979 001	7-35
7-26	AUX DRVR/METER MULT 1A14	992 6429 002	7-36
7-27	PA ARC DETECTOR	992 3012 001	7-37
7-28	MTR LTG ISO BOX 1A16	992 6435 001	7-38
7-29	RESONATOR ASSY	943 0398 003	7-39
7-30	UNIT #2, OUTPUT CUBICLE	992 6312 002	7-40
7-31	DIRECTIONAL COUPLER 2A1	992 4926 001	7-42
7-32	PWB, DIR CPLR 2A1A1	992 4927 001	7-43
7-33	FEEDBACK BOARD 2A3	992 6393 001	7-44
7-34	METER MULTIPLIER 2A4	992 6404 001	7-45
7-35	SWITCH, SHORTING	992 3037 003	7-46
7-36	UNIT #3, STEP START	992 6498 001	7-47

Table 7-2. XMTR, MW50C3 AM 50KW 60HZ - 994 8832 004

REF. SYMBOL	HARRIS PART NO.	DESCRIPTION	QTY	UM
1A09C04	504 0264 000	CAP MICA 680PF 10KV FREQ DET	0.0	
1A09C04	504 0373 000	CAP 1200PF 10KV 5% (292) FREQ DET	0.0	
1A09C04	504 0374 000	CAP 2000PF 15KV 5% (293) FREQ DET	0.0	
1A09C05	504 0365 000	CAP 6200 PF 3KV FREQ DET	0.0	
1A09C05	504 0412 000	CAP 4300PF 3KV FREQ DET	0.0	
1A09C05	504 0413 000	CAP 12000PF 2KV FREQ DET	0.0	
1A09C07	504 0239 000	CAP 2200PF 6KV 5% (291) FREQ DET	0.0	
1A09C07	504 0242 000	CAP. .0036 UF 6KV FREQ DET	0.0	
1A09C07	504 0372 000	CAP 5600PF 4KV 5% (291) FREQ DET	0.0	
1A09C09	504 0239 000	CAP 2200PF 6KV 5% (291) FREQ DET	0.0	
1A09C09	504 0256 000	CAP 1000PF 6KV 5% (291) FREQ DET	0.0	
1A09C09	504 0367 000	CAP 560PF 6KV FREQ DET	0.0	
1A09V01	374 0121 000	TUBE, 4CX1500A	1.0	
1A09V02	374 0099 000	TUBE 4CX35000C	1.0	
1A10A01C01	500 0846 000	CAP, MICA 8200PF 100V 5% FREQ DET	0.0	
1A10A01C01	500 0882 000	CAP 3600PF 500V 5% FREQ DET	0.0	
1A10A01C01	500 0966 000	CAP 2200PF 500VDC 5% FREQ DET	0.0	
1A10C02	500 0835 000	CAP, MICA 470PF 500V 5% FREQ DET	0.0	
1A10C02	500 0852 000	CAP 1000 PF 500V FREQ DET	0.0	
1A10C02	500 0756 000	CAP, MICA 330PF 500V 5% FREQ DET	0.0	
1A10C02A	500 0842 000	CAP, MICA 820PF 300V 5% FREQ DET	0.0	
1A10C02C12	500 0846 000	CAP, MICA 8200PF 100V 5% FREQ DET	0.0	
1A10A02C12	500 0882 000	CAP 3600PF 500V 5% FREQ DET	0.0	
1A10A02C12	500 0966 000	CAP 2200PF 500VDC 5% FREQ DET	0.0	
1C02	516 0208 000	CAP HV 50 UUF 15KV FREQ DET	0.0	

WARNING: Disconnect primary power prior to servicing.

Table 7-2. XMTR, MW50C3 AM 50KW 60HZ - 994 8832 004

REF. SYMBOL	HARRIS PART NO.	DESCRIPTION	QTY	UM
1C24	500 0759 000	CAP, MICA 100PF 500V 5%	0.0	
		FREQ DET		
1C24	500 0813 000	CAP MICA 33UUF 500V	0.0	
		FREQ DET		
1C24	500 0821 000	CAP MICA 68UUF 500V	0.0	
		FREQ DET		
1DS03,1DS04 1DS05	396 0004 000	LAMP, 60W 130V	3.0	
1J02,1J03	612 0412 000	RECP DUPLEX OUTLET	2.0	
1V01	374 0099 000	TUBE 4CX35000C	1.0	
2C04B	512 0053 000	CAP VAC 250UUF	0.0	
2DS01,2DS02 2DS03,2DS04	396 0004 000	LAMP, 60W 130V	4.0	
2J02,2J03	612 0412 000	RECP DUPLEX OUTLET	2.0	
2L03	992 3511 007	TANK COIL, 2L3	0.0	
		FREQ DET		
2L03	992 3511 009	TANK COIL	0.0	
		FREQ DET		
2L03	992 3511 012	TANK COIL 12 TURN	0.0	
		FREQ DET		
2L03	992 3511 014	TANK COIL 14 TURN	0.0	
		FREQ DET		
2L03	992 3511 016	TANK COIL	0.0	
		FREQ DET		
2L03	992 3511 018	TANK COIL	0.0	
		FREQ DET		
2L03	992 3511 022	TANK COIL	0.0	
		FREQ DET		
2L04	992 6444 001	COIL, 6 TURN 2L4	0.0	
		FREQ DET		
2L04	992 6445 001	COIL, 14 TURNS 2L4	0.0	
		FREQ DET		
2L05	943 3777 002	COIL, VAR. 17VC1644	0.0	
		FREQ DET		
2L05	943 3777 012	COIL, VAR 26VC2344	0.0	
		FREQ DET		
3T01	736 0119 000	PWR SUPPLY	1.0	
#2C04B	530 0002 000	FLG MTG TERM FMOB	0	
		FREQ DET		
#1A09C04	829 1769 001	TUBE, CONNECTING	0	
		FREQ DET		
#1A09C04	829 1769 002	CONNECTING TUBE	0	
		FREQ DET		
#2C4B	839 1950 001	MTG. BRKT OUTPUT CAB	0	
		FREQ DET		
#2C04B	839 1950 002	MTG. BRKT OUTPUT CAB	0	
		FREQ DET		

WARNING: Disconnect primary power prior to servicing.

Table 7-2. XMTR, MW50C3 AM 50KW 60HZ - 994 8832 004

REF. SYMBOL	HARRIS PART NO.	DESCRIPTION	QTY	UM
#1C02	929 0613 001	STRAP CAP FREQ DET	0	
	336 0209 000	SCREW DRIVE 0 X .25	4	
	839 9468 059	STRAP, CAPACITOR FREQ DET	0.0	
	994 8832 006	XMTR, BASIC MW50C3	1.0	
	994 8996 001	KIT, FRONT DOOR MW50C3	0.0	

Table 7-3. XMTR, BASIC MW50C3 - 994 8832 006

REF. SYMBOL	HARRIS PART NO.	DESCRIPTION	QTY	UM
#1A10	992 2222 001	CABLE, OSC TEST/DUMMY LOAD	1	
	992 6311 002	UNIT #1, MOD & PA CUBICLE	1	
	992 6312 002	UNIT #2, OUTPUT CUBICLE	1	
	992 6498 001	UNIT #3, STEP-START	1	

Table 7-4. UNIT #1, MOD & PA CUBICLE - 992 6311 002

REF. SYMBOL	HARRIS PART NO.	DESCRIPTION	QTY	UM
1A01	992 6325 001	CONTROL UNIT 1A1	1.0	
1A02	992 6327 002	PDM UNIT 1A2	1.0	
1A03	992 6323 001	FLAG & OVERLOAD 1A3	1.0	
1A04	992 3468 001	SCREEN PWR SUPPLY 1A4	1.0	
1A05	992 3469 001	BIAS PWR SUPPLY 1A5	1.0	
1A07	992 3471 002	DC COUPLER 1A7	1.0	
1A08	992 6326 002	AUDIO DRIVER 1A8	1.0	
1A09	992 6322 002	ISOLATED BOX 1A9	1.0	
1A10	992 6324 001	OSCILLATOR UNIT 1A10	1.0	
1A11	992 6321 001	METER PANEL 1A11	1.0	
1A12	929 1979 001	ASSY, GRD SWITCH	1.0	
1A14	992 6429 002	AUX DRVR/METER MULT 1A14	1.0	
1A15	992 3012 001	PA ARC DETECTOR	1.0	
1A16	992 6435 001	MTR LTG ISO BOX 1A16	1.0	
LCR01	386 0320 000	ZENER, 1N3340A 100V	1.0	
LCR04,LCR05	384 0639 000	RECTIFIER UFS10		
LCR06,LCR07			4.0	
LCR08	384 0676 000	RECTIFIER ASSY	1.0	
LC01	000 0000 007	APPEARS ON LOWER LEVEL	1.0	
LC03,LC04	516 0483 000	CAP 4,000PF 32KV, 120A	2.0	
LC05	500 0477 000	CAP .01UF 10% 2500V	1.0	
LC07,LC08	510 0638 000	CAP 4UF 1000V 10%	2.0	
LC09	510 0551 000	CAP 30 UF 1KV 10%	1.0	
LC10	504 0273 000	CAP .047UF 1500V 5%	1.0	
LC11	510 0552 000	CAP 8UF 1500V	1.0	
LC12	510 0685 000	CAP 2.45UF 40KV	1.0	
LC16	504 0272 000	CAP 7500PF 2KV 5%	1.0	
LC17,LC18	516 0080 000	CAP DISC .01UF 600V	2.0	
LC21	522 0372 000	CAP 2500 UF 15V	1.0	
LC22	504 0350 000	CAP 220PF 30KV	1.0	
LC23	524 0178 000	CAP 860 UF 450V	1.0	
LC24	000 0000 003	FREQUENCY DETERMINED PART	1.0	
LC25	524 0323 000	CAP 1800UF 40V	1.0	
LC30,LC31,LC32	516 0080 000	CAP DISC .01UF 600V		
LC33			4.0	
1E01,1E02,1E03	815 5012 001	SPACER	3.0	
1E04	829 1580 001	CAP, DETECTOR	1.0	
1E05	927 7092 002	CARBON BLOCK ASSY	1.0	
1E06	815 5042 001	BRKT., SPARK GAP	1.0	
1E07	560 0013 000	SPARK GAP 600V	1.0	
1E08	560 0043 000	SPARK GAP 1KV	1.0	
1J01	620 0410 000	JACK, BULKHEAD UG-657/U	1.0	
1J02,1J03	000 0000 002	APPEARS ON A HIGHER LEVEL	0.0	
1J04	620 0410 000	JACK, BULKHEAD UG-657/U	1.0	
1K01	992 3037 002	RELAY, HV SHORTING	1.0	
1K02	572 0161 000	RELAY, MINIATURE	1.0	
1L01	916 9089 001	COIL ASSEMBLY	1.0	
1L02	476 0400 000	REACTOR, MODULATION	1.0	
1L03	000 0000 007	APPEARS ON LOWER LEVEL	0.0	
1L04	927 3879 005	CHOKE, LOW PASS FLTR	1.0	

WARNING: Disconnect primary power prior to servicing.

Table 7-4. UNIT #1, MOD & PA CUBICLE - 992 6311 002 (Continued)

REF. SYMBOL	HARRIS PART NO.	DESCRIPTION	QTY	UM
1L05	942 5580 004	CHOKE ASSY	1.0	
1L06	476 0307 000	REACTOR, FLTR 1.2HY	1.0	
1L07	590 0021 000	SOLENOID 230V 60HZ	1.0	
1L08	915 5024 001	BOARD ASSY, 1L8	1.0	
1M01	630 0178 000	METER 0-15VAC	1.0	
1M02	632 1027 000	METER WITH 0-3/0-12 SCL	1.0	
1M03	632 1059 000	METER, POWER 0-100KW SCL	1.0	
1M04	632 1058 000	METER 0-30KV SCALE	1.0	
1M05	632 1056 000	METER 0-5ADC	1.0	
1M06	632 1057 000	METER 0-12KV SCALE	1.0	
1M4E1,1M6E1	614 0438 000	TERMINAL STAND OFF	2.0	
1PV01	396 0187 000	LAMP, PEC CL5M2	1.0	
1R01	540 0832 000	RES 50.0 OHM 100W 10%	1.0	
1R07	915 5033 001	POTENTIOMETER, MOD.	1.0	
1R09	542 0999 000	RES 1.0 OHM 1089W 33A	1.0	
1R10	552 0292 000	RHEO 175 OHM 12.5W	1.0	
1R11	540 0571 000	RES 22.0 OHM 2W 5%	1.0	
1R12	542 0204 000	RES 5.0 OHM 50W	1.0	
1R13	540 0584 000	RES 75.0 OHM 2W 5%	1.0	
1R14	552 0294 000	RHEO 350 OHM 12.5W	1.0	
1R15	542 0359 000	RES 1.0K OHM 200W	1.0	
1R16	542 0360 000	RES 1.5K OHM 200W	1.0	
1R17	542 0354 000	RES 50.0 OHM 200W	1.0	
1R18	542 0355 000	RES 75.0 OHM 200W	1.0	
1R19	542 0354 000	RES 50.0 OHM 200W	1.0	
1R20	542 0441 000	RES 1.0 OHM 50W	1.0	
1R23	542 0318 000	RES 10.0 OHM 160W	1.0	
1R24,1R25	540 0270 000	RES 2.7 OHM 1W 5%	2.0	
1R27,1R28,1R29	546 0216 000	RES 312 OHM 200W		
1R30,1R31,1R32			6.0	
1R34	542 0294 000	RES 500.0 OHM 100W	1.0	
1R35	915 5034 001	RHEOSTAT & SHAFT	1.0	
1R36	540 0639 000	RES 15.0K OHM 2W 5%	1.0	
1R37	540 0635 000	RES 10.0K OHM 2W 5%	1.0	
1R40	540 0839 000	RES 220.0 OHM 100W 10%	1.0	
1R48	542 0367 000	RES 5.0K OHM 200W	1.0	
1R49	552 0294 000	RHEO 350 OHM 12.5W	1.0	
1R50	540 0839 000	RES 220.0 OHM 100W 10%	1.0	
1R51	540 0659 000	RES 100.0K OHM 2W 5%	1.0	
1R52	540 0839 000	RES 220.0 OHM 100W 10%	1.0	
1R53	540 1314 000	RES 1.0K OHM 150W 10%	1.0	
1R54	542 0283 000	RES 2.0 OHM 100W	1.0	
1R55	548 0329 000	RES 10K OHM 1/2W 1%	1.0	
1R56	548 0050 000	RES 20K OHM 1/2W 1%	1.0	
1R57	542 0105 000	RES 25.0K OHM 12W	1.0	
1R60	540 1185 000	RES 39.0K OHM 1/2W 5%	1.0	
1R61	550 0007 000	POT, 10K OHM .5W	1.0	
1R62	542 0355 000	RES 75.0 OHM 200W	1.0	
1S01	915 3526 006	SWITCH, MODIFIED	1.0	
1S02,1S03,1S04	604 1026 000	SW, DPDT 15A 125/250VAC	3.0	

WARNING: Disconnect primary power prior to servicing.

Table 7-4. UNIT #1, MOD & PA CUBICLE - 992 6311 002 (Continued)

REF. SYMBOL	HARRIS PART NO.	DESCRIPTION	QTY	UM
1S05,1S06	442 0022 000	THERMOSTAT	2.0	
1S07	604 0061 000	SW, SPDT	1.0	
1S08	604 0280 000	SW, PRESS.	1.0	
1S09	928 9309 001	SWITCH ASSY 1S9	1.0	
1S10,1S11	604 1026 000	SW, DPDT 15A 125/250VAC	2.0	
1S12,1S13	604 0450 000	SW, PRECISION DPDT	2.0	
1TB01	614 0328 000	TERM BOARD 27 TERM	1.0	
1TB02	614 0048 000	TERM BOARD 4 TERM	1.0	
1TB03	614 0093 000	TERM BOARD 3 TERM	1.0	
1TB04	614 0057 000	TERM BOARD 13 TERM	1.0	
1TB04	829 9468 184	MARKER STRIP 36 TERM	1.0	
1TB05	614 0053 000	TERM BOARD 9 TERM	1.0	
1TB06	614 0094 000	TERM BOARD 4 TERM	1.0	
1TB07	614 0046 000	TERM BOARD 2 TERM	1.0	
1TB08	614 0048 000	TERM BOARD 4 TERM	1.0	
1TB08	614 0690 000	TERM BOARD 3 TERM	1.0	
1TB09	614 0048 000	TERM BOARD 4 TERM	1.0	
1TB01A	614 0047 000	TERM BOARD 3 TERM	1.0	
1TB10	614 0053 000	TERM BOARD 9 TERM	1.0	
1TB04A	614 0067 000	TERM BOARD 23 TERM	1.0	
1T01	472 0596 000	XFMR, FIL, P11539	1.0	
1T02	472 0605 000	XFMR, PLT, P11540	1.0	
1T04	474 0090 000	XFMR, VAR, VT8LN	1.0	
1T05	472 0622 000	XFMR, CTL, P6377	1.0	
1T06	472 0210 000	XFMR, ISO, N66A	1.0	
1V01	000 0000 002	APPEARS ON HIGHER LEVEL	0.0	
1XK02	404 0200 000	RELAY SOCKET	1.0	
1XQ01	404 0136 000	SOCKET KIT, TRANSISTOR	1.0	
1XU01	404 0309 000	SOCKET SK-1510A	1.0	
	358 0184 000	RETAINER 82 ALL HDS	20	
	358 0185 000	RCPTCL 85 SPRING	10	
	358 0187 000	RCPTCL 82 SPRING	20	
	358 0410 000	RETAINER 85 ALL HDS	8	
	402 0001 000	CLIP, 1.062 FUSE 60A 600V	6	
	402 0002 000	CLIP, .812 FUSE 60A 250V	2	
#1S12,#1S13	402 0107 000	FUSE CLIP	2	
#1B01	432 0307 000	WHEEL, BLOWER 15 X 6	1	
#1B01	436 0253 000	MOTOR 5HP 3PH	1	
#1C23	542 0105 000	RES 25.0K OHM 12W	1	
	620 2411 000	GAUGE, PRESSURE, 0-10"	1.0	
	650 0021 000	KNOB RD SKIRT .911	1	
	650 0148 000	KNOB ROUND 225 3 5G	1	
	650 0149 000	KNOB, ROUND	1	
	815 4279 016	FILTER, REAR DOOR AIR	1	
	816 9062 001	KNOB	2	
	928 0661 001	CABLE ASSY	1	
	929 9468 250	CABLE MOD& PA MAIN MW50C3	1	
	938 3828 036	CABLE, COAX	1	
#1L10,#1R40	939 2056 005	CABLE JUMPER	1	

WARNING: Disconnect primary power prior to servicing.

Table 7-4. UNIT #1, MOD & PA CUBICLE - 992 6311 002 (Continued)

REF. SYMBOL	HARRIS PART NO.	DESCRIPTION	QTY	UM
#1L4,#1V2	939 2056 015	CABLE JUMPER	2	
#1C12,#2L7	939 2056 018	CABLE JUMPER	1	
#1CR8,#1C12	939 2056 020	CABLE, JUMPER	1	
#1C12,#1K1	939 2056 022	CABLE ASSY	1	
#1C01,#1L03	943 0398 003	RESONATOR ASSY	1	

WARNING: Disconnect primary power prior to servicing.

Table 7-5. CONTROL UNIT 1A1 - 992 6325 001

REF. SYMBOL	HARRIS PART NO.	DESCRIPTION	QTY	UM
CB001	606 0148 000	CKT BREAKER 10A 250V 60HZ	1.0	
CB002	606 0508 000	BREAKER,CKT 20A	1.0	
CB003	606 0149 000	CIRCUIT BREAKER 25 A	1.0	
CB004	606 0186 000	CKT BREAKER 35A 250V 60HZ	1.0	
CB005	606 0145 000	CKT BREAKER 1A 250V 60HZ	1.0	
CB006	606 0461 000	BREAKER, CKT 15A	1.0	
CB008	606 0187 000	CKT BREAKER 2A 250V 60HZ	1.0	
CR002	384 0020 000	RECTIFIER IN4005	1.0	
CR003	386 0169 000	ZENER, 1N5352A 15V	1.0	
CR004	384 0020 000	RECTIFIER IN4005	1.0	
C001	524 0181 000	CAP 2700UF 25V	1.0	
DS001,DS002	396 0194 000	LAMP, .014A 10V 344		
DS003,DS004				
DS005,DS006			6.0	
K001	574 0221 000	RELAY 700-NT400-A1	1.0	
K002	570 0120 000	CONTACTOR 40 AMP	1.0	
K003	574 0221 000	RELAY 700-NT400-A1	1.0	
K004	570 0251 000	CONTACTOR 40A 4 POLE	1.0	
K005	574 0221 000	RELAY 700-NT400-A1	1.0	
K006,K007	574 0062 000	RELAY LATCHING 4 PDT	2.0	
K008	574 0219 000	RELAY 4PDT 12VDC	1.0	
K009	574 0225 000	RELAY 6VDC 4PDT	1.0	
K010	574 0220 000	RELAY 4PDT 1000 OHM	1.0	
K011	580 0001 000	RELAY, VACUUM 26.5VDC	1.0	
M001	636 0042 000	METER, ELAPSED TIME 60HZ	1.0	
R001,R002	542 1006 000	RES 5.4 OHM 766W 10%	2.0	
R003	542 1008 000	RES 8.5 OHM 751W 9.4A	1.0	
R004,R005,R006	540 0625 000	RES 3.9K OHM 2W 5%		
R007,R008,R009				
R010,R011			8.0	
R012	542 0183 000	RES 2.0K OHM 25W	1.0	
S001	915 3526 008	SWITCH MODIF.	1.0	
S002,S003	604 0460 000	SW, TGL DPDT	2.0	
TD001	576 0047 000	RLY PNEUMATIC TIMING	1.0	
XDS001,XDS002	406 0384 000	SKT 183-9730-14-602		
XDS003,XDS004				
XDS005,XDS006			6.0	
	406 0377 000	LENS RED .75 IN SQ	6	
	650 0028 000	KNOB RD SKIRT 1.135	1	
	992 3769 003	PWB, RELAY P/O 1A1	1	

Table 7-6. PWB, RELAY P/O 1A1 - 992 3769 003

REF. SYMBOL	HARRIS PART NO.	DESCRIPTION	QTY	UM
CR001	384 0020 000	RECTIFIER IN4005	1.0	
R015	540 0025 000	RES 100.0 OHM 1/2W 5%	1.0	
XK008,XK009	404 0214 000	RELAY SOCKET		
XK010			3.0	
	929 3663 001	PRINTED BOARD	1.0	

Table 7-7. PDM UNIT 1A2 - 992 6327 002

REF. SYMBOL	HARRIS PART NO.	DESCRIPTION	QTY	UM
A01	992 6771 001	PWB, PDM GEN 1A2A1	1.0	
A02	992 5898 001	PWB, AUDIO INPUT 1A2A2	1.0	
A03	992 4474 001	PWB, MOD ENHANCER	1.0	
A04	992 6416 002	PWB, INTERFACE 1A2A4	1.0	
A03DS01	384 0610 000	LED, GREEN	1.0	
A03DS02,A03DS03	384 0611 000	LED, RED	2.0	
A03T01	472 0730 000	XFMR, CTL, P8395	1.0	
B01	550 0919 000	POT 2.5K OHM 117V	1.0	
CR01	386 0320 000	ZENER, 1N3340A 100V	1.0	
CR02	386 0101 000	ZENER, 1N2992A 39V	1.0	
C15	526 0221 000	CAP 150 UF 15V 20%	1.0	
C047	526 0315 000	CAP, 150UF, 15V, 20%	1.0	
J01	620 0410 000	JACK, BULKHEAD UG-657/U	1.0	
R01	548 1518 000	RES 1200 OHM 25W 1%	1.0	
S01	604 0471 000	SW, TGL 4PDT	1.0	
	650 0021 000	KNOB RD SKIRT .911	1	
	929 9468 251	CABLE, MW50C3 PDM	1	

Table 7-8. PWB, PDM GEN 1A2A1 - 992 6771 001

REF. SYMBOL	HARRIS PART NO.	DESCRIPTION	QTY	UM
CR001,CR002	384 0205 000	DIODE SILICON 1N914		
CR003			3.0	
CR004	386 0092 000	ZENER, 1N4744 15V	1.0	
CR005	386 0085 000	ZENER, 1N4740A 10V	1.0	
CR006,CR007	384 0205 000	DIODE SILICON 1N914		
CR008			3.0	
CR010	386 0187 000	ZENER 1N5349A 12V	1.0	
CR011	386 0136 000	ZENER, 1N4745A 16V	1.0	
CR012	386 0085 000	ZENER, 1N4740A 10V	1.0	
C001,C002,C003	500 0882 000	CAP 3600PF 500V 5%	3.0	
C004	516 0393 000	CAP DISC .025UF 500V	1.0	
C005	500 0902 000	CAP 3300PF 500V 5%	1.0	
C006	516 0082 000	CAP, DISC .01UF 1KV GMV	1.0	
C007	506 0236 000	CAP .0047UF 63V 5%	1.0	
C008	500 0783 000	CAP 5100 PF 500V 5%	1.0	
C009	516 0054 000	CAP, DISC .001UF 1KV 10%	1.0	
C010	526 0057 000	CAP 100UF 20V 20%	1.0	
C011	526 0020 000	CAP 15UF 20V 10PCT	1.0	
C012	516 0054 000	CAP, DISC .001UF 1KV 10%	1.0	
C013	500 0837 000	CAP, MICA 510PF 500V 5%	1.0	
C014	506 0245 000	CAP .33UF 63V 5%	1.0	
C015	526 0337 000	CAP 2.7UF 50V 10%	1.0	
L001	492 0344 000	INDTOR VAR VIV-1500	1.0	
Q001,Q002	380 0082 000	XSTR, 2N1893	2.0	
Q003,Q004,Q005	380 0083 000	XSTR, 2N2369	3.0	
Q006	380 0631 000	XSTR, IRF531 (ESD)	1.0	
RT001	559 0048 000	THERMISTOR, DISC 1K OHM	1.0	
R001	540 0075 000	RES 12.0K OHM 1/2W 5%	1.0	
R002	540 0071 000	RES 8.2K OHM 1/2W 5%	1.0	
R003	540 0053 000	RES 1.5K OHM 1/2W 5%	1.0	
R004	540 0047 000	RES 820.0 OHM 1/2W 5%	1.0	
R005	540 0049 000	RES 1.0K OHM 1/2W 5%	1.0	
R006	540 0059 000	RES 2.7K OHM 1/2W 5%	1.0	
R007	540 0068 000	RES 6.2K OHM 1/2W 5%	1.0	
R008	540 0017 000	RES 47.0 OHM 1/2W 5%	1.0	
R009	540 0066 000	RES 5.1K OHM 1/2W 5%	1.0	
R010	540 0053 000	RES 1.5K OHM 1/2W 5%	1.0	
R011	540 0028 000	RES 130.0 OHM 1/2W 5%	1.0	
R012	540 0025 000	RES 100.0 OHM 1/2W 5%	1.0	
R013	540 0050 000	RES 1.1K OHM 1/2W 5%	1.0	
R014	540 0053 000	RES 1.5K OHM 1/2W 5%	1.0	
R015	540 0613 000	RES 1.2K OHM 2W 5%	1.0	
R016	540 0001 000	RES 10.0 OHM 1/2W 5%	1.0	
R017	540 0073 000	RES 10.0K OHM 1/2W 5%	1.0	
R018	540 0001 000	RES 10.0 OHM 1/2W 5%	1.0	
R019	540 0611 000	RES 1.0K OHM 2W 5%	1.0	
R020	540 0608 000	RES 750.0 OHM 2W 5%	1.0	
R021	540 0049 000	RES 1.0K OHM 1/2W 5%	1.0	
R022	540 0073 000	RES 10.0K OHM 1/2W 5%	1.0	

Table 7-8. PWB, PDM GEN 1A2A1 - 992 6771 001

REF. SYMBOL	HARRIS PART NO.	DESCRIPTION	QTY	UM
R023	540 0599 000	RES 330.0 OHM 2W 5%	1.0	
R024	546 0104 000	RES 1500 OHMS 25W 5%	1.0	
R025	540 0017 000	RES 47.0 OHM 1/2W 5%	1.0	
R026	540 1162 000	RES 1.0M OHM 1/2W 5%	1.0	
R027	540 0621 000	RES 2.7K OHM 2W 5%	1.0	
	943 4209 102	PWB, PDM GEN	1	

WARNING: Disconnect primary power prior to servicing.

Table 7-9. PWB, AUDIO INPUT 1A2A2 - 992 5898 001

REF. SYMBOL	HARRIS PART NO.	DESCRIPTION	QTY	UM
CR001	384 0663 000	DIODE BRIDGE VM28	1.0	
CR002	386 0106 000	ZENER, 1N4737 7.5V	1.0	
CR003,CR004	386 0082 000	ZENER, 1N4744A 15V	2.0	
CR005,CR006	384 0205 000	DIODE SILICON 1N914		
CR007,CR008			4.0	
CR009	384 0663 000	DIODE BRIDGE VM28	1.0	
C001,C002,C003	516 0074 000	CAP, DISC .005UF 1KV 20%		
C004			4.0	
C005,C006,C007	500 0759 000	CAP, MICA 100PF 500V 5%		
C008,C009			5.0	
C010	500 0832 000	CAP, MICA 360PF 500V 5%	1.0	
C011	500 0838 000	CAP, MICA 560PF 300V 5%	1.0	
C012	500 0827 000	CAP, MICA 130PF 500V 5%	1.0	
C013,C014	526 0097 000	CAP 47 UF 35V 20%	2.0	
C015,C016	526 0109 000	CAP 22UF 20V 20%	2.0	
C017,C018,C019	522 0524 000	CAP 10 UF 25V 20%		
C020			4.0	
C021	500 0840 000	CAP, MICA 680PF 300V 5%	1.0	
C022,C023,C024	516 0453 000	CAP .1UF 100V 20%		
C025,C026,C027			6.0	
C028	500 0834 000	CAP, MICA 430PF 500V 5%	1.0	
C029	516 0082 000	CAP, DISC .01UF 1KV GMV	1.0	
C030	516 0557 000	CAP, DISC .47UF 12V	1.0	
C031	526 0057 000	CAP 100UF 20V 20%	1.0	
C032	526 0102 000	CAP 150UF 6V 20%	1.0	
C033	522 0256 000	CAP 20 UF 50V	1.0	
C034	526 0050 000	CAP 1 UF 35V 20%	1.0	
C035	522 0367 000	CAP 25UF 25V	1.0	
C037	508 0258 000	CAP .001 UF 600V 10%	1.0	
C038	508 0271 000	CAP .022UF 200V 10%	1.0	
C039,C040	508 0408 000	CAP .1 UF 50V 5%	2.0	
C041	522 0523 000	CAP 470UF 16V	1.0	
C044,C045,C046	500 0759 000	CAP, MICA 100PF 500V 5%	3.0	
K001	572 0127 000	RELAY 4PDT 24VDC	1.0	
L001,L002	494 0419 000	CHOKE RF 1000.OUH	2.0	
L003,L004	494 0199 000	CHOKE RF 2200UH 10%	2.0	
P001	610 0679 000	PLUG, SHORTING	1.0	
Q001	380 0125 000	XSTR, 2N4401	1.0	
Q002	380 0126 000	XSTR, 2N4403	1.0	
R001,R002,R003	540 0889 000	RES 110.0 OHM 1/4W 5%		
R004			4.0	
R005	540 0908 000	RES 680.0 OHM 1/4W 5%	1.0	
R006,R007	540 0936 000	RES 10.0K OHM 1/4W 5%	2.0	
R008,R009	540 0984 000	RES 1.0M OHM 1/4W 5%	2.0	
R010	540 0919 000	RES 2.0K OHM 1/4W 5%	1.0	
R011	550 0958 000	POT 10K OHM 1/2 W 10%	1.0	
R012,R013,R014	540 0936 000	RES 10.0K OHM 1/4W 5%		
R015,R016			5.0	
R017	540 0935 000	RES 9.1K OHM 1/4W 5%	1.0	

WARNING: Disconnect primary power prior to servicing.

Table 7-9. PWB, AUDIO INPUT 1A2A2 - 992 5898 001

REF. SYMBOL	HARRIS PART NO.	DESCRIPTION	QTY	UM
R018	550 0956 000	POT 2000 OHM 1/2W 10%	1.0	
R019	540 1360 000	RES NETWORK 47K OHM 2%	1.0	
R020	540 0935 000	RES 9.1K OHM 1/4W 5%	1.0	
R021,R022	540 0916 000	RES 1.5K OHM 1/4W 5%	2.0	
R023	540 0936 000	RES 10.0K OHM 1/4W 5%	1.0	
R024	550 0443 000	POT 5K OHM .5W 20%	1.0	
R025,R026	550 0958 000	POT 10K OHM 1/2 W 10%	2.0	
R027	540 0936 000	RES 10.0K OHM 1/4W 5%	1.0	
R028	540 0925 000	RES 3.6K OHM 1/4W 5%	1.0	
R029	540 0587 000	RES 100.0 OHM 2W 5%	1.0	
R030	540 0935 000	RES 9.1K OHM 1/4W 5%	1.0	
R031	540 0942 000	RES 18.0K OHM 1/4W 5%	1.0	
R032	540 0922 000	RES 2.7K OHM 1/4W 5%	1.0	
R033	540 0905 000	RES 510.0 OHM 1/4W 5%	1.0	
R034	550 0626 000	POT, 10K OHM .5W 10%	1.0	
R035	540 0929 000	RES 5.1K OHM 1/4W 5%	1.0	
R036	550 0623 000	POT, 5K OHM .5W 10%	1.0	
R037	540 0599 000	RES 330.0 OHM 2W 5%	1.0	
R038	540 0872 000	RES 22.0 OHM 1/4W 5%	1.0	
R039	540 0922 000	RES 2.7K OHM 1/4W 5%	1.0	
R040	540 0916 000	RES 1.5K OHM 1/4W 5%	1.0	
R041	540 0904 000	RES 470.0 OHM 1/4W 5%	1.0	
R042	540 0878 000	RES 39.0 OHM 1/4W 5%	1.0	
R043	540 0628 000	RES 5.1K OHM 2W 5%	1.0	
R044,R045	992 6692 001	PDM POT KIT-MW5/10/50	2.0	
R046	540 0912 000	RES 1.0K OHM 1/4W 5%	1.0	
R047	540 0933 000	RES 7.5K OHM 1/4W 5%	1.0	
R048	540 0936 000	RES 10.0K OHM 1/4W 5%	1.0	
R049	540 0912 000	RES 1.0K OHM 1/4W 5%	1.0	
R050	540 0936 000	RES 10.0K OHM 1/4W 5%	1.0	
R051	540 0928 000	RES 4.7K OHM 1/4W 5%	1.0	
R052	540 0912 000	RES 1.0K OHM 1/4W 5%	1.0	
R053	540 0930 000	RES 5.6K OHM 1/4W 5%	1.0	
R054	540 0899 000	RES 300.0 OHM 1/4W 5%	1.0	
R055	540 0587 000	RES 100.0 OHM 2W 5%	1.0	
R056,R057	540 0912 000	RES 1.0K OHM 1/4W 5%	2.0	
R058	540 0953 000	RES 51.0K OHM 1/4W 5%	1.0	
R059	540 0908 000	RES 680.0 OHM 1/4W 5%	1.0	
R060	540 0936 000	RES 10.0K OHM 1/4W 5%	1.0	
R061	540 0935 000	RES 9.1K OHM 1/4W 5%	1.0	
S001	602 0143 000	SW, LEV DPDT DIP	1.0	
T001	472 0713 000	XFMR, PWR, 815-3143-001	1.0	
U001	382 0552 000	IC, TL074CN3	1.0	
U002	382 0636 000	IC, TL071CP3	1.0	
U003	382 0711 000	IC, AD534-JH	1.0	
XK001	404 0214 000	RELAY SOCKET	1.0	
XR019	404 0675 000	SOCKET, IC 16 CONT	1.0	
XU003	404 0303 000	SOCKET, IC 10 PIN	1.0	
	943 3781 001	PC BD AUDIO INPUT/PDM	1.0	

Table 7-10. PDM POT KIT-MW5/10/50 - 992 6692 001

REF. SYMBOL	HARRIS PART NO.	DESCRIPTION	QTY	UM
#R044, #R045	550 0961 000	POT 50K OHM 1/2W 10%		
#R052, #R053			2	
	939 7051 001	PWB, PDM POT	1	

Table 7-11. PWB, MOD ENHANCER - 992 4474 001

REF. SYMBOL	HARRIS PART NO.	DESCRIPTION	QTY	UM
CR001,CR002	384 0020 000	RECTIFIER IN4005		
CR003,CR004			4.0	
CR005	386 0145 000	ZENER, 1N3022A 12V	1.0	
CR006	384 0134 000	DIODE, SILICON 1N914	1.0	
CR007	386 0145 000	ZENER, 1N3022A 12V	1.0	
CR008	384 0134 000	DIODE, SILICON 1N914	1.0	
C001,C002	522 0417 000	CAP 1000UF 25V	2.0	
F001	398 0011 000	FUSE,FAST CART .250A 250V	1.0	
Q001	380 0126 000	XSTR, 2N4403	1.0	
Q002,Q003	380 0125 000	XSTR, 2N4401	2.0	
Q004	380 0126 000	XSTR, 2N4403	1.0	
R001,R002	540 0018 000	RES 51.0 OHM 1/2W 5%	2.0	
R003	540 0055 000	RES 1.8K OHM 1/2W 5%	1.0	
R004,R005	540 0018 000	RES 51.0 OHM 1/2W 5%	2.0	
R006,R007	540 0025 000	RES 100.0 OHM 1/2W 5%	2.0	
R008	540 0055 000	RES 1.8K OHM 1/2W 5%	1.0	
R009,R010	540 0021 000	RES 68.0 OHM 1/2W 5%	2.0	
R011	540 0059 000	RES 2.7K OHM 1/2W 5%	1.0	
R012,R013	540 0014 000	RES 36.0 OHM 1/2W 5%	2.0	
R014	540 0066 000	RES 5.1K OHM 1/2W 5%	1.0	
R015	540 0615 000	RES 1.5K OHM 2W 5%	1.0	
R016	550 0966 000	POT 2K OHM 1/2W/.3W 10%	1.0	
R017	540 0035 000	RES 270.0 OHM 1/2W 5%	1.0	
R018	540 0332 000	RES 1.0K OHM 1W 5%	1.0	
R019	540 0083 000	RES 27.0K OHM 1/2W 5%	1.0	
R020	550 0966 000	POT 2K OHM 1/2W/.3W 10%	1.0	
R021	540 0035 000	RES 270.0 OHM 1/2W 5%	1.0	
R022	540 0332 000	RES 1.0K OHM 1W 5%	1.0	
R023	540 0083 000	RES 27.0K OHM 1/2W 5%	1.0	
S001	604 0813 000	SW, PB 4 STATIONS	1.0	
TB001	614 0696 000	TERM BOARD 5 TERM	1.0	
	402 0129 000	CLIP FUSE	2	
	939 1062 001	P.C. BOARD	1.0	

Table 7-12. PWB, INTERFACE 1A2A4 - 992 6416 002

REF. SYMBOL	HARRIS PART NO.	DESCRIPTION	QTY	UM
C001	522 0379 000	CAP 100UF 250V	1.0	
C002	508 0497 000	CAP .47UF 600V	1.0	
C003,C004	516 0067 000	CAP DISC .003UF 1KV 20%	2.0	
C005,C006,C007 C008,C009,C010	516 0082 000	CAP, DISC .01UF 1KV GMV		
C011			7.0	
J001	610 0768 000	PC HEADER, 24 PIN	1.0	
R002	540 0594 000	RES 200.0 OHM 2W 5%	1.0	
TB001	614 0726 000	TERM BOARD 15 TERM	1.0	
	943 4209 101	PWB, PDM INTERFACE	1	

Table 7-13. FLAG & OVERLOAD 1A3 - 992 6323 001

<u>REF. SYMBOL</u>	<u>HARRIS PART NO.</u>	<u>DESCRIPTION</u>	<u>QTY</u>	<u>UM</u>
A001	992 6411 001	FLAG & OVERLOAD 1A3A1	1.0	

Table 7-14. FLAG & OVERLOAD 1A3A1 - 992 6411 001

REF. SYMBOL	HARRIS PART NO.	DESCRIPTION	QTY	UM
CR001,CR002	384 0020 000	RECTIFIER IN4005		
CR003,CR004				
CR005,CR006				
CR007,CR008				
CR009,CR010				
CR011,CR012				
CR013,CR014				
CR015,CR016			16.0	
CR017	386 0082 000	ZENER, 1N4744A 15V	1.0	
CR018,CR019	386 0169 000	ZENER, 1N5352A 15V	2.0	
CR020	386 0345 000	ZENER, 1N5342 6.8V	1.0	
CR021,CR022	384 0020 000	RECTIFIER IN4005		
CR023,CR024				
CR025,CR026				
CR027,CR028				
CR029,CR030				
CR031,CR032				
CR033,CR034				
CR035,CR036				
CR037,CR038				
CR039,CR040			20.0	
CR041	386 0091 000	ZENER, 1N4738 8.2V	1.0	
CR042	384 0020 000	RECTIFIER IN4005	1.0	
C001	522 0394 000	CAP 100UF 50V	1.0	
C002	516 0087 000	CAP DISC .05UF 600V	1.0	
C003	522 0251 000	CAP 5 UF 50V	1.0	
C004	516 0082 000	CAP, DISC .01UF 1KV GMV	1.0	
C005	522 0257 000	CAP 35UF 50V	1.0	
C006	522 0254 000	CAP 10 UF 50V	1.0	
C007,C008	516 0082 000	CAP, DISC .01UF 1KV GMV	2.0	
C009,C010,C011	516 0087 000	CAP DISC .05UF 600V		
C012			4.0	
C013	526 0359 000	CAP 47UF 20V 10%	1.0	
C014	526 0053 000	CAP 2.7UF 35V 20%	1.0	
DS001,DS002	384 0611 000	LED, RED		
DS003,DS004				
DS005,DS006				
DS007			7.0	
DS008	384 0610 000	LED, GREEN	1.0	
F001	398 0056 000	FUSE,SLOW CART 1.50A 250V	1.0	
J001,J002	610 0768 000	PC HEADER, 24 PIN	2.0	
K001	572 0127 000	RELAY 4PDT 24VDC	1.0	
K002,K003	574 0352 000	RELAY CORREED CC-12	2.0	
K004,K005,K006	574 0351 000	RLY LATCHING CC-69		
K007,K008,K009				
K010			7.0	
Q001	380 0516 000	XSTR, D45C8	1.0	
Q002,Q003	380 0179 000	XSTR, MPS-U45	2.0	
Q004	380 0204 000	XSTR, D44C9	1.0	

Table 7-14. FLAG & OVERLOAD 1A3A1 - 992 6411 001

REF. SYMBOL	HARRIS PART NO.	DESCRIPTION	QTY	UM
Q005	380 0152 000	XSTR, D40C5	1.0	
R001	540 0615 000	RES 1.5K OHM 2W 5%	1.0	
R002	540 0032 000	RES 200.0 OHM 1/2W 5%	1.0	
R003	540 0049 000	RES 1.0K OHM 1/2W 5%	1.0	
R004	540 0066 000	RES 5.1K OHM 1/2W 5%	1.0	
R005	540 0622 000	RES 3.0K OHM 2W 5%	1.0	
R006	540 0632 000	RES 7.5K OHM 2W 5%	1.0	
R007	540 0622 000	RES 3.0K OHM 2W 5%	1.0	
R008	540 0603 000	RES 470.0 OHM 2W 5%	1.0	
R009	540 0049 000	RES 1.0K OHM 1/2W 5%	1.0	
R010	540 0651 000	RES 47.0K OHM 2W 5%	1.0	
R011	540 0108 000	RES 300.0K OHM 1/2W 5%	1.0	
R012	540 0053 000	RES 1.5K OHM 1/2W 5%	1.0	
R013	540 0025 000	RES 100.0 OHM 1/2W 5%	1.0	
R014	540 0089 000	RES 47.0K OHM 1/2W 5%	1.0	
R015	540 0121 000	RES 1.0M OHM 1/2W 5%	1.0	
R016	540 0073 000	RES 10.0K OHM 1/2W 5%	1.0	
R017	540 0121 000	RES 1.0M OHM 1/2W 5%	1.0	
R018	540 0017 000	RES 47.0 OHM 1/2W 5%	1.0	
R019	540 0608 000	RES 750.0 OHM 2W 5%	1.0	
R020	540 0049 000	RES 1.0K OHM 1/2W 5%	1.0	
R021	550 0626 000	POT, 10K OHM .5W 10%	1.0	
R022	540 0090 000	RES 51.0K OHM 1/2W 5%	1.0	
R023,R024	540 0073 000	RES 10.0K OHM 1/2W 5%	2.0	
R025	540 0049 000	RES 1.0K OHM 1/2W 5%	1.0	
R026,R027	540 0025 000	RES 100.0 OHM 1/2W 5%	2.0	
R028	540 0105 000	RES 220.0K OHM 1/2W 5%	1.0	
R029	540 0049 000	RES 1.0K OHM 1/2W 5%	1.0	
R030	540 0089 000	RES 47.0K OHM 1/2W 5%	1.0	
R031	550 0626 000	POT, 10K OHM .5W 10%	1.0	
R050,R051,R052	540 0615 000	RES 1.5K OHM 2W 5%		
R053,R054,R055				
R056,R057,R058				
R059,R060,R061				
R062,R063			14.0	
R064,R065,R066	540 0065 000	RES 4.7K OHM 1/2W 5%		
R067,R068,R069			6.0	
R070	540 0608 000	RES 750.0 OHM 2W 5%	1.0	
R071	540 0059 000	RES 2.7K OHM 1/2W 5%	1.0	
R072	550 0797 000	POT 50K OHM .5W 10%	1.0	
R073	540 0081 000	RES 22.0K OHM 1/2W 5%	1.0	
R074	540 0121 000	RES 1.0M OHM 1/2W 5%	1.0	
S001	604 0905 000	SW, PB MOMENTARY	1.0	
S002	604 0904 000	SW, TGL SPDT	1.0	
U001	382 0415 000	IC, 324	1.0	
XF001,XF001A	402 0129 000	CLIP FUSE	2.0	
XK001	404 0214 000	RELAY SOCKET	1.0	
	943 4209 033	PWB FLAG & OULD	1	

Table 7-15. BIAS PWR SUPPLY 1A5 - 992 3469 001

REF. SYMBOL	HARRIS PART NO.	DESCRIPTION	QTY	UM
CR001	384 0230 000	RECT 67D030B20TTN	1.0	
C001	508 0326 000	CAP .015UF 1600V 10%	1.0	
C002,C003	524 0178 000	CAP 860 UF 450V	2.0	
L001	476 0289 000	REACTOR 814 5242 001	1.0	
R001	540 0609 000	RES 820.0 OHM 2W 5%	1.0	
R002,R003	542 0105 000	RES 25.0K OHM 12W	2.0	
TB001	614 0094 000	TERM BOARD 4 TERM	1.0	
T001	472 0604 000	XFMR, FIL, 814-5236-001	1.0	
	927 9943 001	CABLE, MOD BIAS SUP	1.0	

Table 7-16. DC COUPLER 1A7 - 992 3471 002

REF. SYMBOL	HARRIS PART NO.	DESCRIPTION	QTY	UM
CR003,CR004 CR005,CR006 CR007	386 0320 000	ZENER, 1N3340A 100V	5.0	
C001	510 0713 000	CAP 10 UF 1500VDC	1.0	
C002	504 0272 000	CAP 7500PF 2KV 5%	1.0	
R001	540 0563 000	RES 10.0 OHM 2W 5%	1.0	
	404 0282 000	HEAT SINK, TAPPED ONE END	5	

Table 7-17. AUDIO DRIVER 1A8 - 992 6326 002

REF. SYMBOL	HARRIS PART NO.	DESCRIPTION	QTY	UM
CR001	386 0085 000	ZENER, 1N4740A 10V	1.0	
J001	620 1677 000	RECEPTACLE, PC MT, BNC	1.0	
Q001	380 0675 000	XSTR, BUZ-53A (ESD)	1.0	
R001	540 0291 000	RES 20.0 OHM 1W 5%	1.0	
R002	540 1131 000	RES 30.0K OHM 1/2W 5%	1.0	
R003	540 1156 000	RES 2.7K OHM 1/2W 5%	1.0	
R004	540 1162 000	RES 1.0M OHM 1/2W 5%	1.0	
R005,R006	540 0849 000	RES 2.0 OHM 1/2W 5%	2.0	
R007	546 0231 000	RES 25 OHM 80W 10%	1.0	
TB001	614 0733 000	TERM BOARD, PC MT 10 TERM	1.0	
#Q001	404 0498 000	HEAT SINK FOR CASE TO-3	1	
#Q001	612 0891 000	JACK, PC MT	2	
	943 4209 108	PWB, AUDIO DRIVER	1	

Table 7-18. ISOLATED BOX 1A9 - 992 6322 002

REF. SYMBOL	HARRIS PART NO.	DESCRIPTION	QTY	UM
A001	992 6408 001	METERING BOARD 1A9A1	1.0	
A002	992 6409 001	METERING & BIAS 1A9A2	1.0	
A004	992 6404 003	METER MULTIPLIER 1A9A4	1.0	
CB001	606 0480 000	BREAKER, CKT 5A	1.0	
CB002	606 0529 000	BREAKER, CKT 30A	1.0	
CB003	606 0187 000	CKT BREAKER 2A 250V 60HZ	1.0	
CB004	606 0145 000	CKT BREAKER 1A 250V 60HZ	1.0	
CR005	384 0229 000	RECT PIV 4KV 12A.	1.0	
CR006	560 0042 000	VARISTOR V510LA80A	1.0	
C001,C002	500 0458 000	CAP .01UF 10% 1200V	2.0	
C003	500 0436 000	CAP .01 UF 600V 10%	1.0	
C006	500 0477 000	CAP .01UF 10% 2500V	1.0	
C010,C011	504 0269 000	CAP MICA .1UF 500V	2.0	
C012	504 0236 000	CAP MICA .01 UF 4KV	1.0	
C013,C014,C015 C016	516 0080 000	CAP DISC .01UF 600V	4.0	
C017,C018,C019	524 0178 000	CAP 860 UF 450V	3.0	
C020	510 0718 000	CAP .1 UF 2500 VDC	1.0	
C021,C022	524 0178 000	CAP 860 UF 450V	2.0	
C029	504 0236 000	CAP MICA .01 UF 4KV	1.0	
C033,C034	504 0269 000	CAP MICA .1UF 500V	2.0	
C035,C036,C037	516 0208 000	CAP HV 50 UUF 15KV	3.0	
C038	516 0206 000	CAP HV 1000 UUF 5000	1.0	
C039	516 0208 000	CAP HV 50 UUF 15KV	1.0	
DS001,DS002 DS003,DS004	396 0060 000	LAMP, .04A 28V 327	4.0	
K001	574 0176 000	RELAY DPDT 110VDC	1.0	
K002	574 0388 000	RELAY 240VAC DPDT	1.0	
L001	943 3777 012	COIL, VAR 26VC2344	1.0	
L002	943 3777 002	COIL, VAR. 17VC1644	1.0	
L003,L004	494 0065 000	CHOKE R F 1 MHY	2.0	
L006	476 0292 000	REACTOR 814 5267 001	1.0	
L007	916 5499 002	PA ARC. SAMPLE	1.0	
L008	476 0307 000	REACTOR, FLTR 1.2HY	1.0	
M001	632 1027 000	METER WITH 0-3/0-12 SCL	1.0	
M002	632 1025 000	METER 0-8ADC	1.0	
M003	630 0178 000	METER 0-15VAC	1.0	
M004	632 0988 000	METER, 0-3A D.C.	1.0	
R001,R002	542 0083 000	RES 2.5K OHM 10W	2.0	
R007	542 0327 000	RES 2.0K OHM 160W	1.0	
R017	546 0227 000	RES 50 OHM 80W 10PCT	1.0	
R020	540 0685 000	RES 1.2M OHM 2W 5%	1.0	
R021	540 0073 000	RES 10.0K OHM 1/2W 5%	1.0	
R022	542 0305 000	RES 20.0K OHM 100W	1.0	
R023	542 0318 000	RES 10.0 OHM 160W	1.0	
R024,R025,R026	542 0105 000	RES 25.0K OHM 12W	3.0	
R027	540 0589 000	RES 120.0 OHM 2W 5%	1.0	
R028	542 0095 000	RES 10.0K OHM 10W	1.0	
R029	542 0105 000	RES 25.0K OHM 12W	1.0	

Table 7-18. ISOLATED BOX 1A9 - 992 6322 002

REF. SYMBOL	HARRIS PART NO.	DESCRIPTION	QTY	UM
R044	542 0166 000	RES 5.0 OHM 25W	1.0	
R045	542 0229 000	RES 25.0K OHM 50W	1.0	
R047,R048	540 0604 000	RES 510.0 OHM 2W 5%	2.0	
R050	542 0317 000	RES 5.0 OHM 160W	1.0	
S001	915 0862 003	SWITCH, MODIFIED	1.0	
S002	604 0386 000	SW, SPDT PIN PLUNGER	1.0	
TB002	614 0079 000	TERM BOARD 12 TERM	1.0	
T001	474 0090 000	XFMR, VAR, VT8LN	1.0	
T002	472 0673 000	XFMR, FIL, P7749	1.0	
T003	472 0596 000	XFMR, FIL, P11539	1.0	
T004	472 0605 000	XFMR, PLT, P11540	1.0	
XDS001,XDS002	406 0384 000	SKT 183-9730-14-602		
XDS003,XDS004			4.0	
XU001	404 0286 000	SOCKET, TUBE SK831	1.0	
XU002	404 0309 000	SOCKET SK-1510A	1.0	
Z001	914 7180 001	PARASITIC SUPP	1.0	
Z004	927 3881 002	SUPPRESSOR, PARASITI	1.0	
Z005	927 3880 002	SUPPRESSOR, PARASITI	1.0	
Z006	927 3881 003	SUPPRESSOR, PARASITI	1.0	
	406 0377 000	LENS RED .75 IN SQ	4	
	650 0021 000	KNOB RD SKIRT .911	1	
	650 0148 000	KNOB ROUND 225 3 5G	2	
	927 9905 001	CABLE ASSY.	1	
	929 9468 155	CABLE, RF DRIVER & OSC	1	
	929 9468 157	CABLE, ISOLATED BOX	1	
	938 5887 001	PANEL, METER	1	

Table 7-19. METERING BOARD 1A9A1 - 992 6408 001

REF. SYMBOL	HARRIS PART NO.	DESCRIPTION	QTY	UM
C001,C002	516 0080 000	CAP DISC .01UF 600V	2.0	
R001	540 0116 000	RES 620.0K OHM 1/2W 5%	1.0	
R002	540 0073 000	RES 10.0K OHM 1/2W 5%	1.0	
R003	540 0116 000	RES 620.0K OHM 1/2W 5%	1.0	
R004	540 0584 000	RES 75.0 OHM 2W 5%	1.0	
R005,R006,R007	540 0616 000	RES 1.6K OHM 2W 5%		
R008,R009,R010			6.0	
R011	540 0630 000	RES 6.2K OHM 2W 5%	1.0	
R012	540 0611 000	RES 1.0K OHM 2W 5%	1.0	
R013	540 0630 000	RES 6.2K OHM 2W 5%	1.0	
Z001,Z002	914 7180 001	PARASITIC SUPP	2.0	
	943 4209 009	ASSY PWB, METERING BOARD	1	

Table 7-20. METERING & BIAS 1A9A2 - 992 6409 001

REF. SYMBOL	HARRIS PART NO.	DESCRIPTION	QTY	UM
CR001,CR002	384 0317 000	RECT, SILICON 1N4725		
CR003,CR004			4.0	
C001	516 0080 000	CAP DISC .01UF 600V	1.0	
C002	500 0458 000	CAP .01UF 10% 1200V	1.0	
C003,C004,C005	516 0080 000	CAP DISC .01UF 600V		
C006			4.0	
C007,C008	508 0497 000	CAP .47UF 600V	2.0	
R001	542 0445 000	RES 75.0 OHM 50W	1.0	
R002,R003	540 0089 000	RES 47.0K OHM 1/2W 5%	2.0	
R004,R005	540 0687 000	RES 1.5M OHM 2W 5%	2.0	
R006	540 0073 000	RES 10.0K OHM 1/2W 5%	1.0	
R007	542 0166 000	RES 5.0 OHM 25W	1.0	
R008,R009	540 0066 000	RES 5.1K OHM 1/2W 5%	2.0	
R010	542 0167 000	RES 10.0 OHM 25W	1.0	
R011	540 0685 000	RES 1.2M OHM 2W 5%	1.0	
R012	540 0073 000	RES 10.0K OHM 1/2W 5%	1.0	
R013,R014,R015	542 0206 000	RES 25.0 OHM 50W		
R016			4.0	
R017	540 0608 000	RES 750.0 OHM 2W 5%	1.0	
	943 4209 010	ASSY PWB, METER BD & BIAS	1	

Table 7-21. METER MULTIPLIER 1A9A4 - 992 6404 003

REF. SYMBOL	HARRIS PART NO.	DESCRIPTION	QTY	UM
C001	522 0256 000	CAP 20 UF 50V	1.0	
R001,R002,R003	548 1539 000	RES 5 MEGOHM 10W 1%		
R004			4.0	
R007	540 0627 000	RES 4.7K OHM 2W 5%	1.0	
	843 4209 107	PWB, METER MULTIPLIER	1	

Table 7-22. PWB, OSCILLATOR 1A10A1&2 - 992 2165 002

REF. SYMBOL	HARRIS PART NO.	DESCRIPTION	QTY	UM
CR001,CR002	386 0092 000	ZENER, 1N4744 15V		
CR003			3.0	
CR004,CR005	384 0205 000	DIODE SILICON 1N914	2.0	
C002	500 0889 000	CAP 75PF 500V 5%	1.0	
C003	502 0216 000	CAP 1600PF 500V 1%	1.0	
C004	516 0387 000	CAP .47 UF 10V	1.0	
C005	502 0218 000	CAP 510PF 500V 1PCT	1.0	
C006	516 0411 000	CAP .1UF 50V DISC	1.0	
C007	516 0438 000	CAP .033UF 25V	1.0	
C008	516 0411 000	CAP .1UF 50V DISC	1.0	
C009	516 0387 000	CAP .47 UF 10V	1.0	
C010	516 0430 000	CAP .02UF 500V 20%	1.0	
C011	526 0015 000	CAP 47UF 20V 10PCT	1.0	
C013	516 0087 000	CAP DISC .05UF 600V	1.0	
L001	494 0194 000	CHOKE RF 120UH	1.0	
Q001,Q002,Q003	380 0083 000	XSTR, 2N2369	3.0	
R001	540 0087 000	RES 39.0K OHM 1/2W 5%	1.0	
R002	540 0340 000	RES 2.2K OHM 1W 5%	1.0	
R003	540 0049 000	RES 1.0K OHM 1/2W 5%	1.0	
R004	540 0079 000	RES 18.0K OHM 1/2W 5%	1.0	
R005	540 0015 000	RES 39.0 OHM 1/2W 5%	1.0	
R006	540 0035 000	RES 270.0 OHM 1/2W 5%	1.0	
R007,R008	540 0065 000	RES 4.7K OHM 1/2W 5%	2.0	
R009	540 0620 000	RES 2.4K OHM 2W 5%	1.0	
R010	540 0049 000	RES 1.0K OHM 1/2W 5%	1.0	
R011	540 0043 000	RES 560.0 OHM 1/2W 5%	1.0	
R012	540 0628 000	RES 5.1K OHM 2W 5%	1.0	
R013	540 0031 000	RES 180.0 OHM 1/2W 5%	1.0	
R014	540 0079 000	RES 18.0K OHM 1/2W 5%	1.0	
R015	540 0019 000	RES 56.0 OHM 1/2W 5%	1.0	
XY001	404 0016 000	SOCKET, TUBE 8 PIN OCTAL	1.0	

Table 7-23. METER PANEL1A11 - 992 6321 001

REF. SYMBOL	HARRIS PART NO.	DESCRIPTION	QTY	UM
A001	992 6437 001	SWITCH BOARD 1A11A1	1.0	
DS001,DS002	396 0060 000	LAMP, .04A 28V 327		
DS003,DS004				
DS005,DS006				
DS007			7.0	
S001	914 9494 002	SELECTOR SW. MOD	1.0	
#A1S2,#A1S7	598 0169 000	SWITCH CAP, PB, RED	2	
#A1S1,#A1S3	598 0170 000	SWITCH CAP, PB, GR		
#A1S6			3	
#A1S4	598 0172 000	SWITCH CAP, PB, BLUE	1	
#A1S5	598 0195 000	SWITCH CAP, PB, YELL	1	
	650 0028 000	KNOB RD SKIRT 1.135	1	

Table 7-24. SWITCH BOARD 1A11A1 - 992 6437 001

REF. SYMBOL	HARRIS PART NO.	DESCRIPTION	QTY	UM
R001,R002,R003	542 0083 000	RES 2.5K OHM 10W		
R004,R005,R006			6.0	
S001,S002,S003	598 0430 000	SWITCH BASE 2 CKT		
S004,S005,S006			7.0	
S007	943 4209 049	PWB ASSY SWITCH	1	

Table 7-25. ASSY, GRD SWITCH - 929 1979 001

REF. SYMBOL	HARRIS PART NO.	DESCRIPTION	QTY	UM
	929 1824 001	ASSY, GRD SWITCH	1	
	604 0061 000	SW, SPDT	2	

Table 7-26. AUX DRVR/METER MULT 1A14 - 992 6429 002

REF. SYMBOL	HARRIS PART NO.	DESCRIPTION	QTY	UM
CR001	000 0000 002	APPEARS ON HIGHER LEVEL	1.0	
CR002	384 0612 000	DIODE 1N3070	1.0	
CR004,CR005	384 0317 000	RECT, SILICON 1N4725		
CR006			3.0	
C002,C003,C004	516 0074 000	CAP, DISC .005UF 1KV 20%	3.0	
Q001	380 0205 000	XSTR, STI804	1.0	
R001,R002	540 0678 000	RES 620.0K OHM 2W 5%	2.0	
R003	540 0635 000	RES 10.0K OHM 2W 5%	1.0	
R004	540 0685 000	RES 1.2M OHM 2W 5%	1.0	
R005	540 0635 000	RES 10.0K OHM 2W 5%	1.0	
R006	540 0685 000	RES 1.2M OHM 2W 5%	1.0	
R007	540 0635 000	RES 10.0K OHM 2W 5%	1.0	
R008,R009	540 0568 000	RES 10.0 OHM 2W 5%	2.0	
R010,R011,R012	540 0270 000	RES 2.7 OHM 1W 5%	3.0	
R013	542 0191 000	RES 10.0K OHM 25W	1.0	
R014	546 0231 000	RES 25 OHM 80W 10%	1.0	
R015,R016	540 0639 000	RES 15.0K OHM 2W 5%	2.0	
R017	552 0825 000	POT 5 OHM 2W	1.0	
TB001	614 0714 000	TERM BOARD 20 TERM	1.0	
#Q001	404 0498 000	HEAT SINK FOR CASE T0-3	1	
#Q001	540 0270 000	RES 2.7 OHM 1W 5%	3	
#Q001	612 0891 000	JACK, PC MT	2	
	943 4209 103	PWB, AUX DRIVER METER MUL	1	

Table 7-27. PA ARC DETECTOR - 992 3012 001

REF. SYMBOL	HARRIS PART NO.	DESCRIPTION	QTY	UM
CR001	384 0232 000	RECTIFIER 2N2324A	1.0	
CR002	384 0205 000	DIODE SILICON 1N914	1.0	
C001	500 0838 000	CAP, MICA 560PF 300V 5%	1.0	
C002	500 0783 000	CAP 5100 PF 500V 5%	1.0	
C003	516 0054 000	CAP, DISC .001UF 1KV 10%	1.0	
C004	516 0081 000	CAP, DISC .01UF 1KV 20%	1.0	
L001	914 7181 001	INDUCTOR	1.0	
R001	550 0067 000	POT 10K OHM 2W 10%	1.0	
R002	540 0049 000	RES 1.0K OHM 1/2W 5%	1.0	
R003	540 0081 000	RES 22.0K OHM 1/2W 5%	1.0	
	915 2028 001	ASSY, PRINTED BD	1.0	

Table 7-28. MTR LTG ISOBOX 1A16 - 992 6435 001

REF. SYMBOL	HARRIS PART NO.	DESCRIPTION	QTY	UM
C001,C002,C003 C004	516 0080 000	CAP DISC .01UF 600V	4.0	
DS001,DS002	396 0111 000	LAMP, 6W 130V 6S6DC130	2.0	
XDS001,XDS002	406 0009 000	SOCKET PILOT LIGHT	2.0	
	943 4209 036	PWB ASSY METER LIGHTING	1	

Table 7-29. RESONATOR ASSY - 943 0398 003

REF. SYMBOL	HARRIS PART NO.	DESCRIPTION	QTY	UM
1C1	514 0145 000	CAP VAR 25-500PF 15 KV	1.0	
1L03	916 6253 001	COIL ASSY	1.0	

WARNING: Disconnect primary power prior to servicing.

Table 7-30. UNIT #2, OUTPUT CUBICLE - 992 6312 002

REF. SYMBOL	HARRIS PART NO.	DESCRIPTION	QTY	UM
2A01	992 4926 001	DIRECTIONAL COUPLER 2A1	1.0	
2A03	929 1979 001	ASSY, GRD SWITCH	1.0	
2A03	992 6393 001	FEEDBACK BOARD 2A3	1.0	
2A04	992 6404 001	METER MULTIPLIER 2A4	1.0	
2A05	740 0115 000	SENSOR, DC CURRENT	1.0	
2B01	436 0129 000	MOTOR 1/4HP 50/60HZ	1.0	
2C01	516 0483 000	CAP 4,000PF 32KV, 120A	1.0	
2C02	514 0284 000	CAP 30-650 PF 45KV	1.0	
2C03	514 0240 000	CAP 50-2300 PF 15KV	1.0	
2C03A	516 0816 000	CAP 4000PF 32KV	1.0	
2C04	514 0042 000	CAP VAR 12-500PF 15KV	1.0	
2C04A	512 0056 000	CAP VAC 500UUF	1.0	
2C04B	000 0000 003	FREQUENCY DETERMINED PART	1.0	
2C05	512 0056 000	CAP VAC 500UUF	1.0	
2C06	504 0364 000	CAP .1 UF 3KV	1.0	
2C07	504 0366 000	CAP .1 UF 1 KV	1.0	
2C09,2C10	516 0439 000	CAP 2700 PF 40KV	2.0	
2C11	516 0483 000	CAP 4,000PF 32KV, 120A	1.0	
2C12,2C13,2C14	510 0685 000	CAP 2.45UF 40KV	3.0	
2C18,2C19	516 0207 000	CAP HV 25 UUF 15KV	2.0	
2C02A	512 0351 000	CAP, VAC 1000PF 50KV	1.0	
2C20,2C21	516 0207 000	CAP HV 25 UUF 15KV	2.0	
2C22	500 0783 000	CAP 5100 PF 500V 5%	1.0	
2C23,2C24	516 0087 000	CAP DISC .05UF 600V	2.0	
2C25	516 0206 000	CAP HV 1000 UUF 5000	1.0	
2C26	516 0812 000	CAP, CER 3000PF 32KV 20%	1.0	
2E01	560 0013 000	SPARK GAP 600V	1.0	
2J01	620 0410 000	JACK, BULKHEAD UG-657/U	1.0	
2K01	992 3037 003	SWITCH, SHORTING	1.0	
2L01	927 9845 001	RF CHOKE	1.0	
2L02	938 3234 001	COIL, CHOKE ASSY.	1.0	
2L03,2L04,2L05	000 0000 003	FREQUENCY DETERMINED PART	3.0	
2L06	938 3234 003	COIL, CHOKE ASSY	1.0	
2L07	938 3234 001	COIL, CHOKE ASSY.	1.0	
2R07,2R08,2R09	540 0839 000	RES 220.0 OHM 100W 10%	5.0	
2R10,2R11			5.0	
2R14	542 1006 000	RES 5.4 OHM 766W 10%	1.0	
2R15	540 1314 000	RES 1.0K OHM 150W 10%	1.0	
2R16	542 0325 000	RES 1.0K OHM 160W	1.0	
2S01,2S02	604 1026 000	SW, DPDT 15A 125/250VAC	2.0	
2S03	604 0525 000	SW, PRESS.	1.0	
2S04,2S05	604 1026 000	SW, DPDT 15A 125/250VAC	2.0	
2S06,2S07	604 0450 000	SW, PRECISION DPDT	2.0	
2TB01	614 0275 000	TERM BOARD 4 TERM	1.0	
2TB02	614 0546 000	TERM BLOCK BTH30	1.0	
2TB03	614 0047 000	TERM BOARD 3 TERM	1.0	
2TB04	614 0053 000	TERM BOARD 9 TERM	1.0	
2TB05	614 0056 000	TERM BOARD 12 TERM	1.0	
2TB06,2TB07	614 0048 000	TERM BOARD 4 TERM	2.0	

Table 7-30. UNIT #2, OUTPUT CUBICLE - 992 6312 002

REF. SYMBOL	HARRIS PART NO.	DESCRIPTION	QTY	UM
2T01	472 1140 000	XFMR, ISO, E17976	1.0	
2T02	474 0088 000	XFMR, AUTO, 815-3618-001	1.0	
	358 0185 000	RCPTCL 85 SPRING	4	
	358 0410 000	RETAINER 85 ALL HDS	2	
	402 0107 000	FUSE CLIP	2	
	452 0053 000	GEAR 913 0972 001	2	
	452 0054 000	GEAR 913 0972 002	2	
#2C02,#2C03	650 0148 000	KNOB ROUND 225 3 5G	2	
	815 4279 016	FILTER, REAR DOOR AIR	1	
#2C04,#2L05	816 9062 001	KNOB	2	
	928 0522 001	CABLE ASSY	1	
	929 9468 136	CABLE, COUPLER CAB #2	1	
	929 9468 253	CABLE, OUTPUT UNIT #2	1	
#2K01,#2L07	939 2056 006	CABLE JUMPER	1	
#2K1-2,#2R14-1	939 2056 007	CABLE JUMPER	1	
#2C11,#2L02	939 2056 012	CABLE JUMPER	1	
#2C01,#2L01	939 2056 013	CABLE JUMPER	1	
#2L02,#2L07	939 2056 014	CABLE JUMPER	1	
#2C13,#2L07	939 2056 017	CABLE JUMPER	1	
#OUTPUT,#2L05	939 2056 021	CABLE, JUMPER	1	

Table 7-31. DIRECTIONAL COUPLER 2A1 - 992 4926 001

REF. SYMBOL	HARRIS PART NO.	DESCRIPTION	QTY	UM
A001	992 4927 001	PWB, DIR CPLR 2A1A1	1.0	
C013	814 6327 001	PLATE, CAP.	1.0	
T001	914 6686 001	TRANSFORMER	1.0	
T002	916 6270 001	XFMR COIL ASSY	1.0	

Table 7-32. PWB, DIR CPLR 2A1A1 - 992 4927 001

REF. SYMBOL	HARRIS PART NO.	DESCRIPTION	QTY	UM
CR001	384 0134 000	DIODE, SILICON 1N914	1.0	
CR002	386 0383 000	ZENER, LVA43A 4.3V	1.0	
CR003,CR004	384 0134 000	DIODE, SILICON 1N914	2.0	
C001	500 0806 000	CAP MICA 15UUF 500V	1.0	
C002	500 0848 000	CAP TRIMMER 9 180UUF	1.0	
C003	500 0826 000	CAP, MICA 120PF 500V 5%	1.0	
C004	520 0119 000	CAP VAR 6.7-140PF	1.0	
C005	522 0244 000	CAP 50 UF 25V	1.0	
C006	526 0337 000	CAP 2.7UF 50V 10%	1.0	
C007	516 0082 000	CAP, DISC .01UF 1KV GMV	1.0	
C008	500 0829 000	CAP, MICA 180PF 500V 5%	1.0	
C009,C010	520 0119 000	CAP VAR 6.7-140PF	2.0	
C011	500 0832 000	CAP, MICA 360PF 500V 5%	1.0	
C012	516 0082 000	CAP, DISC .01UF 1KV GMV	1.0	
C014	500 0837 000	CAP, MICA 510PF 500V 5%	1.0	
K001	574 0352 000	RELAY CORREED CC-12	1.0	
L001	494 0190 000	CHOKER, RF 3300 UH 80 MA	1.0	
Q001	384 0232 000	RECTIFIER 2N2324A	1.0	
Q002	380 0204 000	XSTR, D44C9	1.0	
R001,R002	540 0594 000	RES 200.0 OHM 2W 5%	2.0	
R003	540 0097 000	RES 100.0K OHM 1/2W 5%	1.0	
R004	540 0073 000	RES 10.0K OHM 1/2W 5%	1.0	
R005	540 0053 000	RES 1.5K OHM 1/2W 5%	1.0	
R007	540 0097 000	RES 100.0K OHM 1/2W 5%	1.0	
R008	550 0410 000	POT 25K OHM 1/4W	1.0	
R009	540 0056 000	RES 2.0K OHM 1/2W 5%	1.0	
R010	540 0049 000	RES 1.0K OHM 1/2W 5%	1.0	
R011	540 0025 000	RES 100.0 OHM 1/2W 5%	1.0	
R012,R013	540 0095 000	RES 82.0K OHM 1/2W 5%	2.0	
R014,R015,R016	540 0587 000	RES 100.0 OHM 2W 5%		
R017			4.0	
R018,R019	540 0095 000	RES 82.0K OHM 1/2W 5%	2.0	
R020,R021	550 0378 000	POT 100K OHM 1/4W	2.0	
TJ001,TJ002	610 0679 000	PLUG, SHORTING		
TJ003			3.0	
	939 2679 001	PRINTED BOARD	1.0	

Table 7-33. FEEDBACK BOARD 2A3 - 992 6393 001

REF. SYMBOL	HARRIS PART NO.	DESCRIPTION	QTY	UM
CR001,CR002	384 0612 000	DIODE 1N3070	2.0	
C001	500 0910 000	CAP, 6200PF 300V 5%	1.0	
C002	516 0067 000	CAP DISC .003UF 1KV 20%	1.0	
L001,L002	494 0199 000	CHOKE RF 2200UH 10%	2.0	
	604 0061 000	SW, SPDT	2	
	943 4209 035	PWB, FEEDBACK	1	

Table 7-34. METER MULTIPLIER 2A4 - 992 6404 001

REF. SYMBOL	HARRIS PART NO.	DESCRIPTION	QTY	UM
R001,R002,R003	548 1539 000	RES 5 MEGOHM 10W 1%		
R004,R005,R006	843 4209 004	PWB METER MULTIPLIER	6.0	
			1	

Table 7-35. SWITCH, SHORTING - 992 3037 003

<u>REF. SYMBOL</u>	<u>HARRIS PART NO.</u>	<u>DESCRIPTION</u>	<u>QTY</u>	<u>UM</u>
	590 0037 000	SOLENOID 240V 60HZ	1	
	827 6207 001	CONTACT, INTL SW.	2.0	

Table 7-36. UNIT #3, STEP START - 992 6498 001

REF. SYMBOL	HARRIS PART NO.	DESCRIPTION	QTY	UM
3K01	570 0119 000	CONTACTOR 40AMP	1.0	
3K02	570 0214 000	CONTACTOR 240VAC	1.0	
3K03,3K04,3K05	582 0046 000	RELAY, MAG OVERLOAD	3.0	
3R01,3R02,3R03	542 1006 000	RES 5.4 OHM 766W 10%	3.0	
3S01,3S02,3S03	442 0083 000	THERMOSTAT	3.0	
3TB01	614 0056 000	TERM BOARD 12 TERM	1.0	
	929 9468 137	CABLE, STEP START PANEL	1	
	929 9468 138	CABLE, STEP START PNL	1	

WARNING: Disconnect primary power prior to servicing.

Table 7-37. SCREEN PWR SUPPLY 1A4 - 992 3468 001

REF. SYMBOL	HARRIS PART NO.	DESCRIPTION	QTY	UM
CR001	384 0229 000	RECT PIV 4KV 12A.	1.0	
C001	510 0718 000	CAP .1 UF 2500 VDC	1.0	
C002,C003,C004	524 0178 000	CAP 860 UF 450V	3.0	
	852 9112 001	SCHEM OVERALL MW50C	1.0	
	839 6587 164	SCHEM, PDM MODULATOR	1.0	
	852 9113 001	SCHEM, OVERALL MW50C3	1.0	
R001,R002	540 0584 000	RES 75.0 OHM 2W 5%	2.0	
R003,R004,R005	542 0105 000	RES 25.0K OHM 12W	3.0	

Table 7-38. OSCILLATOR UNIT 1A10 - 992 6324 001

REF. SYMBOL	HARRIS PART NO.	DESCRIPTION	QTY	UM
CR001	386 0057 000	ZENER, 1N4736 6.8V	1.0	
CR002	386 0028 000	ZENER, 1N2992B 39V	1.0	
CR003	384 0220 000	RECT 1000PIV 1.5A SBR10	1.0	
C001	520 0139 000	CAP VAR 13.5-320PF	1.0	
C003	526 0221 000	CAP 150 UF 15V 20%	1.0	
C004	508 0278 000	CAP .1UF 100V WMF1P1	1.0	
C005	524 0138 000	CAP 700UF 150V	1.0	
C006	508 0270 000	CAP .1 UF 400V	1.0	
C007,C008	520 0340 000	CAP VAR 2.2 34PF	2.0	
L003	476 0287 000	CHOKE, FILTER 16/4 H	1.0	
P001	610 0242 000	PLUG 16 CONTACT	1.0	
Q001,Q002	380 0601 000	XSTR, D44C11	2.0	
R001	915 5033 002	POT MODIFICATION	1.0	
R002	540 0587 000	RES 100.0 OHM 2W 5%	1.0	
R003	540 0604 000	RES 510.0 OHM 2W 5%	1.0	
R004	542 0084 000	RES 3.0K OHM 10W	1.0	
R005	542 0179 000	RES 750.0 OHM 25W	1.0	
R006	540 0563 000	RES 10.0 OHM 2W 5%	1.0	
R007	540 0670 000	RES 300.0K OHM 2W 5%	1.0	
R008	540 0073 000	RES 10.0K OHM 1/2W 5%	1.0	
R009	542 0042 000	RES 5.0K OHM 5W	1.0	
R010	540 0589 000	RES 120.0 OHM 2W 5%	1.0	
S001	600 0189 000	SWITCH SELECTOR	1.0	
T001	472 0595 000	XFMR, PLT, 814-5279-001	1.0	
	839 6587 040	SCHEM. RF OSCILLATOR	0	
	914 6178 001	COIL ASSY, OSC.	2	

WARNING: Disconnect primary power prior to servicing.

SECTION VIII

WIRE LIST

8-1. INTRODUCTION

8-2. This section provides wire running lists for the HARRIS MW-50C3 MEDIUM WAVE AM BROADCAST TRANSMITTER and the various components making up this unit. Each individual wire is identified by number from origin and terminal to termination. The following wire running lists are contained in this section.

<u>TITLE</u>	<u>NUMBER</u>
MOD and PA Cabinet	817 1494 050
PDM Cable	817 1494 051
RF Oscillator (1A10)	815 5172 001
RF Isolated Enclosure Cable (1A9)	815 5171 001
RF Isolated Enclosure (1A9)	817 1494 019
RF Driver Grid and Oscillator Cable (1A9)	817 1494 020
500-Volt Bias Supply Cable (1A5)	815 5181 001
Cabinet 2 Cable	817 1494 014
Step-Start	817 1494 022
Cabinet 2 Cubicle Coupler	817 1494 015
External	816 6338 001
Meter and Switch Cable	817 1494 054
Cabinet 1 Interlock Mod and PA	817 1494 018
Cabinet 2 Interlock Output	817 1494 013
Cabinet 2 Cable (Output)	817 1494 053

DATE		RUNNING SHEET		CABLE NO.	
03-19-85		817-1494-050		REV	
WIRE NO.	FROM		WIRE SIZE AND TYPE	TO	
	EQUIPMENT	TERMINAL		EQUIPMENT	TERMINAL
1	2TB2	1	#6 STRANDED	1A1K4	T1
2	2TB2	2	#6 STRANDED	1A1K4	T2
3	2TB2	3	#6 STRANDED	1A1K4	T3
4	2TB2	4	#10 STRANDED	1R9	1
5	2TB2	5	#10 STRANDED	1A1CB4	2
6	2TB2	6	#10 STRANDED	1A1K4	L1
7	1A1CB4	1	#10 STRANDED	1A1K4	L2
8	1A1CB3	1	#10 STRANDED	1A1K4	L2
9	1A1CB3	3	#10 STRANDED	1A1K4	L3
10	1A1CB3	2	#10 STRANDED	1T1	1
11	1A1CB3	4	#10 STRANDED	1T4	3
12	1T4	2	#10 STRANDED	1T1	5
13	1T4	1	#10 STRANDED	1T1	2
14	CAB #1	GRD. STUD	#10 STRANDED	CAB #2	GRD STUD
15	1A1K4	T1	#12 STRANDED	1A1K3	3
16	1A1K4	T2	#12 STRANDED	1A1K3	5
17	1A1K4	T3	#12 STRANDED	1A1K3	7
18	1A1K3	4	#12 STRANDED	1A1R1	1
19	1A1K3	6	#12 STRANDED	1A1K4	L2
20	1A1K3	8	#12 STRANDED	1A1R2	1
21	1A1R2	2	#12 STRANDED	1A1K4	L1
22	1A1R1	2	#12 STRANDED	1A1K4	L3
23	2TB2	7	#14 STRANDED	1A1CB1	1
24	2TB2	8	#14 STRANDED	1A1CB1	3
25	1A1CB1	2	#14 STRANDED	1TB6	1
26	1A1CB1	4	#14 STRANDED	1TB6	2

MOD and PA Cabinet
817 1494 050
(Sheet 1 of 13)

888-2213-001
8-3/8-4

WARNING: Disconnect primary power prior to servicing.

DATE		RUNNING SHEET		CABLE NO. REV	
03-19-85		817-1494-050		A	
WIRE NO.	FROM		WIRE SIZE AND TYPE	TO	
	EQUIPMENT	TERMINAL		EQUIPMENT	TERMINAL
27	1A1K4	T1	#14 STRANDED	1A1CB2	1
28	1A1K4	T2	#14 STRANDED	1A1CB2	3
29	1A1K4	T3	#14 STRANDED	1A1CB2	5
30	1A1CB2	2	#14 STRANDED	1A1K2	T1
31	1A1CB2	4	#14 STRANDED	1A1K2	T2
32	1A1CB2	6	#14 STRANDED	1A1K2	T3
33	1A1K2	L1	#14 STRANDED	1TB3	1
34	1A1K2	L2	#14 STRANDED	1TB3	2
35	1A1K2	L3	#14 STRANDED	1TB3	3
36	1A1K4	L1	#14 STRANDED	1A1CB6	1
37	1A1K4	L3	#14 STRANDED	1A1CB6	3
38	1A1CB6	2	#14 STRANDED	1A1K5	9
39	1A1CB6	4	#14 STRANDED	1A1K7	B9
40	1A1K7	B1	#14 STRANDED	1A1R3	1
41	1A1R3	2	#14 STRANDED	1T2	3
42	1A1K7	B4	#14 STRANDED	1T2	2
43	1A1K5	10	#14 STRANDED	1T2	1
44	1TB4	24	#14 STRANDED	1R9	2
45	1TB4	25	#14 STRANDED	GRD	STUD
46	2TB2	9	#16 STRANDED	1A1K2	L1
47	2TB2	10	#16 STRANDED	1A1K2	L2
48	2TB2	11	#16 STRANDED	1A1K2	L3
49	1A1CB5	1	#16 STRANDED	1A1CB6	4
50	1A1CB5	2	#16 STRANDED	1A5TB1	1
51	1A1K5	10	#16 STRANDED	1A5TB1	2
52					

MOD and PA Cabinet
817 1494 050
(Sheet 2 of 13)

888-2213-001
8-5/8-6

WARNING: Disconnect primary power prior to servicing.

DATE 03-19-85		RUNNING SHEET 817-1494-050		CABLE NO.REV	
WIRE NO.	FROM		WIRE SIZE AND TYPE	TO	
	EQUIPMENT	TERMINAL		EQUIPMENT	TERMINAL
53					
54					
55					
56					
57					
58	1A1K1	2	#16 STRANDED	1TB6	3
59	1A1R7	1	#16 STRANDED	1TB6	3
60	1A1K4	1	#16 STRANDED	1TB6	4
61	1A1R8	1	#16 STRANDED	1TB6	4
62	1A1M1	1	#16 STRANDED	2TB2	12
63	1TB5	1	#16 STRANDED	2TB2	13
64	1TB5	2	#16 STRANDED	1S2B	NO
65	1A1R9	1	#16 STRANDED	1TB7	1
66	1A1R9	1	#16 STRANDED	2TB2	14
67	1TB5	3	#16 STRANDED	2TB2	15
68	1TB5	4	#16 STRANDED	1S7	NO
69	1A1R10	1	#16 STRANDED	1S13	COM
70	1A1R10	1	#16 STRANDED	1TB1	1
71	1A1R11	1	#16 STRANDED	1TB1	2
72	1A1R11	1	#16 STRANDED	1A1K4	T4
73	1A1K4	T4	#16 STRANDED	1K1	1
74	1K1	1	#16 STRANDED	2TB2	16
75	1K1	2	#16 STRANDED	2TB2	17
76	1K1	2	#16 STRANDED	1A1K1	5
77	1A1R7	1	#16 STRANDED	1S5	1
78	1S6	1	#16 STRANDED	1S5	2

MOD and PA Cabinet
817 1494 050
(Sheet 3 of 13)

888-2213-001
8-7/8-8

WARNING: Disconnect primary power prior to servicing.

DATE 03-19-85		RUNNING SHEET 817-1494-050		CABLE NOREV	
WIRE NO.	FROM		WIRE SIZE AND TYPE	TO	
	EQUIPMENT	TERMINAL		EQUIPMENT	TERMINAL
79	1S6	2	#16 STRANDED	1A1R6	1
80	1S6	2	#16 STRANDED	1S8	N0
81	1S8	COM	#16 STRANDED	2TB2	18
82	1A1R5	1	#16 STRANDED	2TB2	19
83	1A1R5	1	#16 STRANDED	1A1CB2	9
84					
85	1A1CB3	7	#16 STRANDED	1A1CB4	3
86	1A1CB4	5	#16 STRANDED	1A1CB5	5
87	1A1CB5	4	#16 STRANDED	1A1CB6	7
88	1A1CB6	6	#16 STRANDED	1A1R4	1
89	1A1TD1	2	#16 STRANDED	1A1PCB	7
90					
91	1A1K1	10	#16 STRANDED	1A1R4	1
92	1A1M1	1	#16 STRANDED	1A1R8	1
93	1A1M1	2	#16 STRANDED	1A1K3	11
94	1A1K4	1	#16 STRANDED	1A1K2	1
95	1A1K4	1	#16 STRANDED	1A1K3	2
96	1A1K2	1	#16 STRANDED	1A1K3	10
97	1A1K3	2	#16 STRANDED	1A1K5	5
98	1A1K3	10	#16 STRANDED	1A1K5	11
99	1A1K5	13	#16 STRANDED	1A1S2	2
100	1A1K3	2	#16 STRANDED	1A1TD1	2
101	1A1K5	11	#16 STRANDED	1TB4	15
102	1A1K2	2	#16 STRANDED	1A1K1	11
103	1A1K1	9	#16 STRANDED	1A1K3	11
104	1A1K3	1	#16 STRANDED	1A1K1	9

MOD and PA Cabinet
817 1494 050
(Sheet 4 of 13)

888-2213-001
8-9/8-10

WARNING: Disconnect primary power prior to servicing.

DATE 03-19-85		RUNNING SHEET 817-1494-050		CABLE NOREV	
WIRE NO.	FROM		WIRE SIZE AND TYPE	TO	
	EQUIPMENT	TERMINAL		EQUIPMENT	TERMINAL
105	1A1K3	12	#16 STRANDED	1A1K4	2
106	1A1K4	T4	#16 STRANDED	1TB4	2
107	1A1CR2	CATH	#16 STRANDED	1TB4	3
108	1A1K7	B12	#16 STRANDED	1A1K1	2
109	1A1K7	B12	#16 STRANDED	1A1K1	12
110	1A1K1	12	#16 STRANDED	1A1K6	B12
111	1A1K6	A11	#16 STRANDED	1A1PCB	1
112	1A1K6	B12	#16 STRANDED	1A1K1	6
113	1A1K1	6	#16 STRANDED	1A1K1	8
114					
115	1A1K5	14	#20 STRANDED	1A1K11	3
116	1A1K4	2	#16 STRANDED	1A1TD1	B1
117	1A1TD1	B2	#16 STRANDED	1A1K3	1
118	1TB4	4	#16 STRANDED	1TB1	11
119	1TB4	4	#16 STRANDED	1T5	1
120	1TB4	5	#16 STRANDED	1T5	4
121	1TB4	5	#16 STRANDED	1A1K1	4
122	1A1K1	4	#16 STRANDED	1A1K6	A9
123	1A1K6	A9	#16 STRANDED	1A1K1	1
124	1A1K1	1	#16 STRANDED	1A1S1	3
125	1A1K1	3	#16 STRANDED	1A1K6	A4
126	1A1K1	3	#16 STRANDED	1A1S1	4
127	1A1S1	5	#16 STRANDED	1TB4	6
128	1A1K6	B11	#16 STRANDED	1A1PCB	2
129	1A1K6	B11	#16 STRANDED	1TB4	7
130	1A1K6	B1	#16 STRANDED	1A1K5	3

MOD and PA Cabinet
817 1494 050
(Sheet 5 of 13)

888-2213-001
8-11/8-12

WARNING: Disconnect primary power prior to servicing.

DATE 03-19-85		RUNNING SHEET 817-1494-050		CABLE NO. REV	
WIRE NO.	FROM		WIRE SIZE AND TYPE	TO	
	EQUIPMENT	TERMINAL		EQUIPMENT	TERMINAL
131	1A1K6	B9	#16 STRANDED	1A1K5	4
132	1A1K5	4	#16 STRANDED	1A1S1	8
133	1A1K5	4	#16 STRANDED	1A1K4	L4
134	1A1K5	3	#16 STRANDED	1A1K5	1
135	1A1K5	2	#16 STRANDED	1A1PCB	12
136	1A1K1	8	#16 STRANDED	1TB1	11
137	1A1K11	4	#20 STRANDED	1TB1	3
138	1A1S1	11	#16 STRANDED	1TB4	1
139	1TB4	19	#16 STRANDED	1A1PCB	6
140	1A1CB5	1	#16 STRANDED	1A1S2	2
141	1A1S2	1	#16 STRANDED	1A1S3	2
142	1A1S2	1	#16 STRANDED	1L7	1
143	1A1S2	5	#16 STRANDED	1A1K5	12
144	1A1S2	6	#16 STRANDED	1A1K5	6
145	1A1S2	6	#16 STRANDED	1A1S3	6
146	1A1S2	4	#16 STRANDED	1A1S3	5
147	1A1S3	4	#16 STRANDED	1A1CR2	CATH
148	1A1K6	A11	#16 STRANDED	1A1CR3	ANODE
149	1T2	1	#16 STRANDED	1L7	2
150	1A1K7	B11	#16 STRANDED	1TB4	8
151	1A1K7	A12	#16 STRANDED	1TB4	9
152	1A1K7	A1	#16 STRANDED	1TB4	10
153	1A1K7	A4	#16 STRANDED	1TB4	11
154	1A1PCB	5	#16 STRANDED	1TB4-	34
155	1A1PCB	5	#16 STRANDED	1A2TB1	3
156	1A3A1J1	17	#20 STRANDED	1A2TB1	4

MOD and PA Cabinet
817 1494 050
(Sheet 6 of 13)

888-2213-001
8-13/8-14

WARNING: Disconnect primary power prior to servicing.

DATE 03-19-88		RUNNING SHEET 817-1494-050		CABLE NO. REV	
WIRE NO.	FROM		WIRE SIZE AND TYPE	TO	
	EQUIPMENT	TERMINAL		EQUIPMENT	TERMINAL
157	1A3A1J2	22	#22 GREEN	1C25	-
158	1A3A1J2	11	#20 STRANDED	1C25	+
159	1A1K7	A10	#16 STRANDED	1A2TB1	4
160	1A1K7	A3	#16 STRANDED	GRD	STUD
161	1A2TB1	14	#20 STRANDED	1A3A1J2	13
162	1A1K3	1	#16 STRANDED	1TB4	12
163	1A1K3	9	#16 STRANDED	1TB4	13
164	1A1K1	7	#16 STRANDED	1TB4	14
165	1A1K6	A12	#16 STRANDED	1TB4	1
166	1A1K6	A6	#16 STRANDED	1TB4	16
167	1A1K4	L4	#16 STRANDED	1TB4	17
168	1A1K5	1	#16 STRANDED	1TB4	18
169	1A14TB1	14	#16 STRANDED	1R23	2
170					
171	1A9A4	E3	#16 STRANDED	1TB4	23
172	1A3A1J1	21	#20 STRANDED	1TB4	22
173	1A3A1J1	23	#20 STRANDED	1TB4	23
174	1A1S3	1	#16 STRANDED	1TB1	5
175	1L7	2	#16 STRANDED	1TB1	6
176	1A14TB1	1	#16 STRANDED	1A7C2	2
177	1A3A1J2	24	#20 STRANDED	1T5	8
178	1A3A1J2	23	#20 STRANDED	1T5	5
179					
180	1A3A1J2	20	#20 STRANDED	1TB4	19
181	1M1	-	#16 STRANDED	1T1	6
182	1M1	+	#16 STRANDED	1T1	8

MOD and PA Cabinet
817 1494 050
(Sheet 7 of 13)

888-2213-001
8-15/8-16

WARNING: Disconnect primary power prior to servicing.

DATE 03-19-85		RUNNING SHEET 817-1494-050		CABLE NO. REV	
WIRE NO.	FROM		WIRE SIZE AND TYPE	TO	
	EQUIPMENT	TERMINAL		EQUIPMENT	TERMINAL
183	1M2	-	#16 STRANDED	1S1	A12
184	1M2	+	#16 STRANDED	1S1	B12
185	1A8TB1	3	#20 STRANDED	1S1	B1
186	1A8TB1	4	#16 STRANDED	1S1	A1
187	1A8TB1	5	#16 STRANDED	1S1	B2
188	1A14TB1	12	#16 STRANDED	1S1	B3
189	1A14TB1	3	#16 STRANDED	1S1	A4
190	1A14TB1	13	#16 STRANDED	1S1	B5
191	1R37	1	#16 STRANDED	1S1	A6
192	1A14TB1	10	#16 STRANDED	1S1	B7
193	1A14TB1	5	#16 STRANDED	1S1	A7
194	1A2TB1	6	#16 STRANDED	1TB4	15
195	1A2TB1	5	#16 STRANDED	1TB1	9
196	1A2TB1	7	#16 STRANDED	1TB1	10
197	1A2TB1	12	#16 STRANDED	1R10	2
198	1A2TB1	14	#16 STRANDED	1R16	1
199	1R10	1	#16 STRANDED	1R9	1
200	1C21	1	#16 STRANDED	1R9	2
201	1C21	1	#16 STRANDED	1A1PCB	11
202	1R10	2	#16 STRANDED	1A1PCB	10
203	1R12	1	#16 STRANDED	1K2	1
204	1R12	2	#16 STRANDED	1R14	1
205	1R7	3	#16 STRANDED	1R14	1
206	1A9A4	E4	#16 STRANDED	1R7	1
207	1A5TB1	1	#16 STRANDED	1TB4	20
208	1A5TB1	2	#16 STRANDED	1TB4	21

MOD and PA Cabinet
817 1494 050
(Sheet 8 of 13)

888-2213-001
8-17/8-18

WARNING: Disconnect primary power prior to servicing.

DATE 03-19-89		RUNNING SHEET 817-1494-050		CABLE NO. REV	
WIRE NO.	FROM		WIRE SIZE AND TYPE	TO	
	EQUIPMENT	TERMINAL		EQUIPMENT	TERMINAL
209	1A5TB1	3	#16 STRANDED	1A14TB1	7
210	1A5TB1	4	#16 STRANDED	1R12	2
211	1A5TB1	4	#16 STRANDED	1A4 GRD	STUD
212					
213	1A4C4	-	#16 STRANDED	1R12	1
214	1A1PCB	13	#16 STRANDED	1TB1	7
215	1A1R12	1	#16 STRANDED	1TB1	8
216	1A1K11	1	#20 STRANDED	1A3A1J1	4
217	1A1K11	2	#20 STRANDED	1A2TB1	3
218	1TB4	15	#16 STRANDED	1TB1	15
219	1A1S1	2	#16 STRANDED	1TB1	16
220	1TB4	8	#16 STRANDED	1TB1	18
221	1TB4	9	#16 STRANDED	1TB1	17
222	1A1S1	9	#16 STRANDED	1TB1	19
223	1TB4	18	#16 STRANDED	1TB1	20
224	1TB4	25	#16 STRANDED	1TB1	21
225	1TB4	19	#16 STRANDED	1TB1	22
226					
227					
228					
229					
230					
231	1C23	-	#16 STRANDED	GRD, STUD	
232	1A14CR1	1	#16 STRANDED	1A14TB1	9
233	1R48	1	#16 STRANDED	1A14TB1	9
234R	1A2TB1	1	#8451 BELDEN	1TB2	1

MOD and PA Cabinet
817 1494 050
(Sheet 9 of 13)

888-2213-001
8-19/8-20

WARNING: Disconnect primary power prior to servicing.

DATE 03-19-85		RUNNING SHEET 817-1494-050		CABLE NO. REV	
WIRE NO.	FROM		WIRE SIZE AND TYPE	TO	
	EQUIPMENT	TERMINAL		EQUIPMENT	TERMINAL
234B	1A2TB1	2	#8451 BELDEN	1TB2	2
234S	1A2TB1	GRD. STUD	#8451 BELDEN	1TB2	3
235	1A14TB1	15	#16 STRANDED	1R30	1
236	1R27	1	#16 STRANDED	1A7C2	1
237W	1A3A1J1	22	#8411 BELDEN	1TB1	23
237S	1A3A1J1	19	#8411 BELDEN	1TB1	24
238W	1A3A1J1	5	#8411 BELDEN	1A1PCB	8
238S	1A3A1J1	11	#8411 BELDEN	1A1PCB	9
239W	1A3A1J1	9	#8411 BELDEN	1K2	6
239S	1A3A1J1	10	#8411 BELDEN	1K2	7
240W	1A3A1J1	13	#8411 BELDEN	1A2TB1	8
240S	1A3A1J1	18	#8411 BELDEN	1A2TB1	10
241W	1A3A1J1	2	#8411 BELDEN	1A1PCB	4
241S	1A3A1J1	7	#8411 BELDEN	1A1TP1	1
242W	1A3A1J1	16	#8411 BELDEN	1A15	1
242S	1A3A1J1	12	#8411 BELDEN	1A15	2
243W	1A3A1J1	14	#8411 BELDEN	1TB1	25
243S	1A3A1J1	15	#8411 BELDEN	1TB1	24
244W	1A3A1J2	17	#8411 BELDEN	2TB2	27
244S	1A3A1J2	18	#8411 BELDEN	2TB2	28
245W	1A3A1J1	3	#8411 BELDEN	1TB4	30
245S	1A3A1J1	7	#8411 BELDEN	1TB4	31
246	1L6	1	#18 RED TURBO	1A4CR1	+

MOD and PA Cabinet
817 1494 050
(Sheet 10 of 13)

888-2213-001
8-21/8-22

WARNING: Disconnect primary power prior to servicing.

DATE		RUNNING SHEET		CABLE NO.	
03-19-85		817-1494-050		REV A	
WIRE NO.	FROM		WIRE SIZE AND TYPE	TO	
	EQUIPMENT	TERMINAL		EQUIPMENT	TERMINAL
247	1L6	2	#18 RED TURBO	1A4C2	+
248	1L6	2	#18 RED TURBO	1R15	2
249	1R19	2	#18 RED TURBO	1R23	1
250	1R34	1	#18 RED TURBO	1L2	1
251	1R35	1	#18 RED TURBO	1R62	2
252	1A4CR1	AC1	#18 RED TURBO	1T2	4
253	1A4CR1	AC2	#18 RED TURBO	1T2	6
254	1L2	1	#18 RED TURBO	1R29	2
255	1R62	2	#18 RED TURBO	1R17	1
256	1R48	2	#18 RED TURBO	1R15	2
257	1TB7	2	#16 STRANDED	1S11B	COM
258	1A1S1	12	#16 STRANDED	1TB1	14
259	1C12	2	#10 STRANDED	GRD.	STUD
260W	2TB2	29	#8411 BELDEN	1TB1	26
260S	2TB2	30	#8411 BELDEN	1TB1	27
261W	1L8	2	RG58/U COAX	1R49	3
261S	1L8	1	RG58/U CDAX	1R49	GRD. LUG
262W	1A1PCB	3	#8411 BELDEN	1TB1	12
262S	1A1TP1	1	#8411 BELDEN	1TB1	13
263W	1C25	+	#8411 BELDEN	1TB4	32
263S	1C25	-	#8411 BELDEN	1TB4	33
264W	1R54	1	#8411 BELDEN	1A3A1J2	21
264S	1R54	2	#8411 BELDEN	1A3A1J2	22
265R	1A3A1J2	12	#8451 BELDEN	1TB4	34
265B	1A3A1J2	16	#8451 BELDEN	1TB4	35
265S	1A3A1J2	15	#8451 BELDEN	1TB4	36

MOD and PA Cabinet
817 1494 050
(Sheet 11 of 13)

888-2213-001
8-23/8-24

WARNING: Disconnect primary power prior to servicing.

DATE		RUNNING SHEET		817-1494-050		CABLE NO. REV		C M	
WIRE NO.	FROM		WIRE SIZE AND TYPE	TO					
	EQUIPMENT	TERMINAL		EQUIPMENT	TERMINAL				
273	1A2TB1	13	#16 STRANDED	1TB4	4				
274	1A1K4	4	#16 STRANDED	1A1K1	12				
275	1A1K4	3	#16 STRANDED	1A1K1	11				
276	1A1TD1	B1	#16 STRANDED	1A1TD1	1				
27B	1TB3	1	#14 STRANDED	1B1	1+7				
279	1TB3	2	#14 STRANDED	1B1	2+8				
2B0	1TB3	3	#14 STRANDED	1B1	3+9				
281W	2TB2	23	#8411 BELDEN	1TB4	26				
281S	2TB2	22	#8411 BELDEN						
282	2TB2	26	#12 STRANDED	1TB4	27				
283	2TB2	25	#12 STRANDED	1TB4	28				
284	2TB2	24	#12 STRANDED	1TB4	29				
285	1S13	NO	#16 STRANDED	1S12	COM				
286	1S12	NO	#16 STRANDED	1S7	COM				
287	1S11B	NO	#16 STRANDED	1S10	COM				
2B8	1S10B	NO	#16 STRANDED	1S2A	COM				
290	1S10	COM	#16 STRANDED	1S11A	COM				
291	1S1D	NO	#16 STRANDED	1S11A	NO				
292	1S11A	COM	#16 STRANDED	1TB5	7				
293	1S11A	NO	#16 STRANDED	1TB5	9				
294	1S2B	COM	#16 STRANDED	1TB5	7				
295	1S2B	NC	#16 STRANDED	1TB5	B				
296	1TB4	27	#12 STRANDED	1TB5	5				
297	1TB4	28	#12 STRANDED	1TB5	6				
29B	1TB4	29	#12 STRANDED	1TB5	7				
299	1TB5	8	#12 STRANDED	1TB9	1				

MOD and PA Cabinet
817 1494 050-C
(Sheet 12 of 13)

888-2213-008
8-25/8-26

WARNING: Disconnect primary power prior to servicing.

DATE		3-25-85		RUNNING SHEET		817-1494-051		CABLE NO.		A	
WIRE NO.	FROM		WIRE SIZE AND TYPE	TO							
	EQUIPMENT	TERMINAL		EQUIPMENT	TERMINAL						
1R	1A2A4P1	17	8451 BELDEN	S1	2						
1B	1A2A4P1	13	8451 BELDEN	S1	5						
1S	1A2A4P1	14	8451 BELDEN	CUT	OFF						
3	1A2A4P1	9	#20 STRANDED	1A2A2	I						
4	1A2A4P1	5	#20 STRANDED	1A2A2	J						
5	1A2A4P1	1	#20 STRANDED	B1	1						
6	1A2A4P1	3	#20 STRANDED	B1	2						
7	1A2A4P1	4	#20 STRANDED	B1	3						
8	1A2A4P1	8	#20 STRANDED	1A2A2	K						
9W	1A2A4P1	12	RG196/U COAX	1A2A2	N						
9S	1A2A4P1	11	RG196/U COAX	CUT	OFF						
10	1A2A4P1	21	#20 STRANDED	1A2A1	C						
11W	1A2A4P1	16	RG196/U COAX	1A2A2	M						
11S	1A2A4P1	15	RG196/U COAX	CUT	OFF						
12	1A2A4P1	20	#20 STRANDED	1A2A2	L						
13	1A2A1	C	#20 STRANDED	1A2A2	C						
14W	1A2A4P1	22	#8411 BELDEN	1A1A1	-H						
14S	1A2A4P1	23	#8411 BELDEN								
15	1A2A4P1	24	#20 STRANDED	1A2A1	D						
16	R41	1	#20 STRANDED	1A2A2	E						
17	R41	2	#20 STRANDED	1A2A2	D						
18	R41	3	#20 STRANDED	1A2A2	F						
19W	J1	COND	RG196/U COAX	1A2A1	F						
19S	J1	SHLD	RG196/U COAX	1A2A1	G						
20	1A2A1	A	#20 STRANDED	1A2A2	A						
21	1A2A1	B	#20 STRANDED	1A2A2	B						

PDM Cable
017 1494 051
(Sheet 1 of 2)

888-2213-001
8-29/8-30

WARNING: Disconnect primary power prior to servicing.

DATE		3-25-85 RUNNING SHEET		817-1494-051		CABLE NO. A	
WIRE NO.	FROM		WIRE SIZE AND TYPE	TO			
	EQUIPMENT	TERMINAL		EQUIPMENT	TERMINAL		
36	1A2A4P1	2	8451 BELDEN	1A2A3-	1		
37R	S1	1	8451 BELDEN	1A2A3-TB1	2		
37B	S1	4	8451 BELDEN	1A2A3-TB1	1		
37S	CUT	OFF	8451 BELDEN	1A2A3-TB1	3		
38R	S1	7	8451 BELDEN	1A2A3-TB1	5		
38B	S1	10	8451 BELDEN	1A2A3-TB1	4		
38S	CUT	OFF	8451 BELDEN	1A2A3-TB1	3		
39R	S1	11	8451 BELDEN	1A2A2	G		
39B	S1	8	8451 BELDEN	1A2A2	H		
39S	S1	GND STUD	8451 BELDEN	CUT	OFF		
40	1A2A4P1	6	#20 STRANDED	1A2A3	2		
41	1A2A3	2	#20 STRANDED	1A2A2	P		
42	1A2A3	3	#20 STRANDED	1A2A2	R		
			(JUMPERS)				
	CR2	CATH	#20 BUSS SPAGHETTI	R1	1		
	CR1	CATH	#20 BUSS SPAGHETTI	R1	2		
	S1	9	#20 BUSS SPAGHETTI	S1	6		
	S1	12	#20 BUSS SPAGHETTI	S1	3		
	1A2A4	E2	#20 STRANDED	R1	1		
	1A2A4	E1	#20 STRANDED	R1	2		

PDM Cable
817 1494 051
(Sheet 2 of 2)

888-2213-001
8-31/8-32

WARNING: Disconnect primary power prior to servicing.

DATE		RUNNING SHEET		CABLE NO.	
6-5-72		815-5172-001			
WIRE NO.	FROM		WIRE SIZE AND TYPE	TO	
	EQUIPMENT	TERMINAL		EQUIPMENT	TERMINAL
1	P1	1	#20 STRANDED	T1	1
2	P1	2	#20 STRANDED	T1	2
3	P1	3	#20 STRANDED	T1	3
4	P1	4	#20 STRANDED	T1	4
5	P1	5	#20 STRANDED	R7	2
6	P1	6	#20 STRANDED	R2	2
7	P1	7	#20 STRANDED	GRD	LUG
8	P1	8	#20 STRANDED	C1	STATOR
9	T1	5	#20 STRANDED	CR3	AC
10	T1	7	#20 STRANDED	CR3	AC
11	R4	2	#20 STRANDED	S1B	1
12	R6	2	#20 STRANDED	S1A	4
13	S1B	2	#20 STRANDED	OSC#1	A
14	S1B	3	#20 STRANDED	OSC#2	A
15	S1A	2	#20 STRANDED	OSC#1	C
16	S1A	3	#20 STRANDED	OSC#2	C
17	CR1	ANODE	#20 STRANDED	R1	2
18	R2	1	#20 STRANDED	R1	1
19	L3	2	#20 STRANDED	R4	1

RF Oscillator (1A10)
815 5172 001-01

888-2213-001
8-33/8-34

WARNING: Disconnect primary power prior to servicing.

DATE 6-6-72		RUNNING SHEET 815-5171-001		CABLE NO. <i>M</i>	
WIRE NO.	FROM		WIRE SIZE AND TYPE	TO	
	EQUIPMENT	TERMINAL		EQUIPMENT	TERMINAL
	2T1	5	3/8" TUBING AND SPAGETTI	TB1	1
	2T1	6	3/8" TUBING AND SPAGETTI	TB1	2
	V2	PLT CONN	5/16" TUBING	C35	1
	C37	FEED THRU	5/16" TUBING	C5	2
	C5	2	1/2" STRAP	L2	1
	C5	?	1/2" STRAP	L1	1
	XV2	FIL 1	1/2" STRAP	C10	2
	XV2	FIL 2	1/2" STRAP	C11	2
	XV2	SCY 1	1/2" STRAP	C12	2
	XV2	SCY 2	1/2" STRAP	C29	2
	TB1	1	1/2" STRAP	C33	2
	TB1	2	1/2" STRAP	C34	2
	P7	2	1/2" STRAP	R7	GND STUD
	L3	1	#16 STRANDED	C6	2
	L3	2	#16 STRANDED	L1	1
	L4	2	#16 STRANDED	C7	1
	R44	1	#16 STRANDED	C38	2
	R44	2	#16 STRANDED	E1	1
	A2R6	1	#16 STRANDED	C8	2
	C21	+	#16 STRANDED	C22	-
	C17	-	#16 STRANDED	C18	+
	C18	-	#16 STRANDED	C19	+
	C31	1	#16 STRANDED	C32	2
	C32	2	#20 BUSS	GND	LUG
	L6	2	#18 STRANDED TURBO	E1	1

RF Isolated Enclosure Cable (1A9)
815 5171 001-A1
(Sheet 1 of 2)

888-2213-001
8-35/8-36

WARNING: Disconnect primary power prior to servicing.

DATE		RUNNING SHEET		CABLE NO.	
9-26-83	817-1494-019				
WIRE NO.	FROM		WIRE SIZE AND TYPE	TO	
	EQUIPMENT	TERMINAL		EQUIPMENT	TERMINAL
1	TB1	1	#12 STRANDED	T1	3
2	TB1	2	#12 STRANDED	T3	1
3	T1	1	#12 STRANDED	T3	5
4	T1	2	#12 STRANDED	T3	2
5	TB1	1	#14 STRANDED	S2	C
6	TB1	2	#14 STRANDED	T4	1
7	S2	NU	#12 STRANDED	K1	3
8	TIE POINT	1	#12 STRANDED	CB2	1
9	CB2	2	#14 STRANDED	T4	2
10	T3	7	#14 STRANDED	M2	+
11	M2	-	#12 STRANDED	GND	LUG
12	K1	1	#16 STRANDED	US1	1
13	K2	2	#16 STRANDED	CB1	3
14	CB1	5	#16 STRANDED	US1	2
15	CB2	5	#16 STRANDED	US2	2
16	CB33	5	#16 STRANDED	US3	2
17	CB4	5	#16 STRANDED	US4	2
18	C20	1	#16 STRANDED	CK5	-
19	C20	1	#16 STRANDED	K22	1
20	R22	1	#16 STRANDED	C19	-
21	CK5	-	#16 STRANDED	K23	1
22	K23	1	#16 STRANDED	C31	2
23	C19	-	#16 STRANDED	K1	1
24	K23	2	#16 STRANDED	M4	+
25	M4	-	#16 STRANDED	M2	+
26	C32	1	#16 STRANDED	Tb2	11

RF Isolated Enclosure (1A9)
817 1494 019
(Sheet 1 of 5)

888-2213-001
8-39/8-40

WARNING: Disconnect primary power prior to servicing.

DATE		RUNNING SHEET		CABLE NO.	
9-26-83	817-1494-019				
WIRE NO.	FROM		WIRE SIZE AND TYPE	TO	
	EQUIPMENT	TERMINAL		EQUIPMENT	TERMINAL
27	T4	1	#16 STRANDED	C21	+
28	Tb2	1	#16 STRANDED	CB4	2
29	Tb2	2	#16 STRANDED	CB3	2
30	Tb2	3	#16 STRANDED	T3	4
31	Tb2	4	#16 STRANDED	A2	E13
32	Tb2	5	#16 STRANDED	A2	E1
33	Tb2	6	#16 STRANDED	S1B	2
34	Tb2	7	#16 STRANDED	S1A	2
35	Tb2	8	#16 STRANDED	S1A	3
36	Tb2	9	#16 STRANDED	S1B	3
37	Tb2	10	#16 STRANDED	K7	1
38	Tb2	12	#16 STRANDED	S1B	1
39	T3	1	#16 STRANDED	CB3	1
40	T3	6	#16 STRANDED	K18	2
41	T3	8	#16 STRANDED	R19	2
42	T1	3	#16 STRANDED	CB4	1
43	CB1	1	#16 STRANDED	K1	3
44	CB1	2	#16 STRANDED	A2	E15
45	C22	-	#16 STRANDED	K28	1
46	C22	+	#16 STRANDED	A2	E14
47	A2	E14	#16 STRANDED	K1	1
48	A2	E4	#16 STRANDED	S1A	4
49	A2	E3	#16 STRANDED	S1B	4
50	A2	E5	#16 STRANDED	S1A	5
51	A2	E7	#16 STRANDED	S1B	5
52	A2	E11	#16 STRANDED	S1A	6

RF Isolated Enclosure (1A9)
817 1494 019
(Sheet 2 of 5)

888-2213-001
8-41/8-42

WARNING: Disconnect primary power prior to servicing.

DATE	RUNNING SHEET		CABLE NO.		
9-26-83	817-1494-019				
WIRE NO.	FROM		WIRE SIZE AND TYPE	TO	
	EQUIPMENT	TERMINAL		EQUIPMENT	TERMINAL
53	A2	E9	#16 STRANDED	S1A	7
54	A2	E10	#16 STRANDED	S1B	7
55	R21	1	#16 STRANDED	S1A	8
56	R21	2	#16 STRANDED	S1B	8
57	S1A	12	#16 STRANDED	M1	-
58	S1B	12	#16 STRANDED	M1	+
59	CR5	AC1	#18 RED TURBO	T4	4
60	CR5	AC2	#18 RED TURBO	T4	5
61	CR5	+	#18 RED TURBO	L8	1
62	R22	2	#18 RED TURBO	C17	+
63	R22	2	#18 RED TURBO	L8	2
64	L8	2	#18 RED TURBO	L6	1
65					
66					
67	E2	1	#18 RED TURBO	A2	E6
68	A2	E6	#18 RED TURBO	L3	1
70	C21	-	#18 RED TURBO	A2	E13
72	A2	E8	#18 RED TURBO	L4	1

RF Isolated Enclosure (1A9)
817 1494 019
(Sheet 3 of 5)

888-2213-001
8-43/8-44

WARNING: Disconnect primary power prior to servicing.

DATE		RUNNING SHEET		CABLE NO.	
9-26-83		817-1494-019			
WIRE NO.	FROM		WIRE SIZE AND TYPE	TO	
	EQUIPMENT	TERMINAL		EQUIPMENT	TERMINAL
	2T1	5	3/8" TUBING & SPAGHETTI	TB1	1
	2T1	6	"	TB1	2
	V2	PLT CONN	5/16" TUBING	C35	1
	C37	FEED THRU	"	C5	2
	C5	2	1/2" STRAP	L2	1
	C5	2	"	L1	1
	XV2	FIL. 1	"	C10	2
	XV2	FIL. 2	"	C11	2
	XV2	SCR. 1	"	C12	2
	XV2	SCR. 2	"	C29	2
	Tb1	1	"	C33	2
	Tb1	2	"	C34	2
	K7	2	"	K7	Gnd Stud
	L3	1	#16 STRANDED	C6	2
	L3	2	#16 STRANDED	L1	1
	L4	2	#16 STRANDED	C7	1
	R44	1	#16 STRANDED	C38	2
	R44	2	#16 STRANDED	E1	1
	C21	+	#16 STRANDED	C22	-
	C17	-	#16 STRANDED	C18	+
	C18	-	#16 STRANDED	C19	+
	C31	1	#16 STRANDED	C32	2
	C32	2	#20 BUSS	Gnd	Lug
	Cb1, Cb2, Cb3, & Cb4	TERM 3	#20 Bussea together		
	DS1, DS2, DS3, & DS4	TERM 1	#20 Bussea together		
	S1 TERM B5, A7, A8		#20 Bussea together		

RF Isolated Enclosure (1A9)
817 1494 019
(Sheet 4 of 5)

888-2213-001
8-45/8-46

WARNING: Disconnect primary power prior to servicing.

DATE		RUNNING SHEET		CABLE NO.	
9-26-83		817 1494 020			
WIRE NO.	FROM		WIRE SIZE AND TYPE	TO	
	EQUIPMENT	TERMINAL		EQUIPMENT	TERMINAL
1	TB2	1	#16 STRANDED	J1	1
2	TB2	2	#16 STRANDED	J1	4
3	TB2	3	#16 STRANDED	T2	3
4	TB2	4	#16 STRANDED	A1	E4
5	TB2	5	#16 STRANDED	T2	5
6	TB2	6	#16 STRANDED	A1	E5
7	TB2	7	#16 STRANDED	A1	E6
8	TB2	8	#16 STRANDED	A1	E8
9	TB2	9	#16 STRANDED	A1	E9
10	TB2	10	#16 STRANDED	C3	1
11	TB2	11	#16 STRANDED	J1	6
12	TB2	12	#16 STRANDED	J1	5
13	TB2	2	#16 STRANDED	T2	1
14	TB2	5	#16 STRANDED	A1	E7
			(NOT IN CABLE)		
15W	J1	8	#18 253-0021-000	A1	E2
15S	J1	GndLug	"	A1	E1
16	T2	4	#10 STRANDED	XV1	Fil 1
17	T2	6	#10 STRANDED	XV1	Fil 2
	XV1	Fil 1	1/2" STRAP	C1	2
	XV1	Fil 2	"	C2	2
	J1	2	#20 BUSS	J1	3
	J1	7	#20 BUSS	J1	GndLug
	A1	E10	#20 Buss & Spagetti	1A9C3	2
	A1	E3	#20 Buss & Spagetti	XV1	GRD

RF Driver Grid and Oscillator Cable (1A9)
817 1494 020
(Sheet 1 of 2)

888-2213-001
8-49/8-50

WARNING: Disconnect primary power prior to servicing.

DATE		RUNNING SHEET		CABLE NO.	
9-26-83		817 1494 020			
WIRE NO.	FROM		WIRE SIZE AND TYPE	TO	
	EQUIPMENT	TERMINAL		EQUIPMENT	TERMINAL
1	TB2	1	#16 STRANDED	J1	1
2	TB2	2	#16 STRANDED	J1	4
3	TB2	3	#16 STRANDED	T2	3
4	TB2	4	#16 STRANDED	A1	E4
5	TB2	5	#16 STRANDED	T2	5
6	TB2	6	#16 STRANDED	A1	E5
7	TB2	7	#16 STRANDED	A1	E6
8	TB2	8	#16 STRANDED	A1	E8
9	TB2	9	#16 STRANDED	A1	E9
10	TB2	10	#16 STRANDED	C3	1
11	TB2	11	#16 STRANDED	J1	6
12	TB2	12	#16 STRANDED	J1	5
13	TB2	2	#16 STRANDED	T2	1
14	TB2	5	#16 STRANDED	A1	E7
			(NOT IN CABLE)		
15W	J1	8	#18 253-0021-000	A1	E2
15S	J1	GndLug	"	A1	E1
16	T2	4	#10 STRANDED	XV1	Fil 1
17	T2	6	#10 STRANDED	XV1	Fil 2
	XV1	Fil 1	1/2" STRAP	C1	2
	XV1	Fil 2	"	C2	2
	J1	2	#20 BUSS	J1	3
	J1	7	#20 BUSS	J1	GndLug
	A1	E10	#20 Buss & Spaghetti	1A9C3	2
	A1	E3	#20 Buss & Spaghetti	XV1	GRD

RF Driver Grid and Oscillator Cable (1A9)
817 1494 020
(Sheet 2 of 2)

888-2213-001
8-51/8-52

WARNING: Disconnect primary power prior to servicing.

DATE 8-26-3		RUNNING SHEET 817 1494-014		CABLE NO. REV AM	
WIRE NO.	FROM		WIRE SIZE AND TYPE	TO	
	EQUIPMENT	TERMINAL		EQUIPMENT	TERMINAL
1	2TB1	1	#6 STRANDED	2T2	2
2	2TB1	2	#6 STRANDED	2T2	9
3	2TB1	3	#6 STRANDED	2T2	16
4	2TB1	4	#6 STRANDED	GND	STUD
5	2T2	22	#6 STRANDED	2TB2	1
6	2T2	23	#6 STRANDED	2TB2	2
7	2T2	24	#6 STRANDED	2TB2	3
8	2E2	1	#10 STRANDED	2TB2	4
9	2T1	1	#10 STRANDED	2TB2	5
10	2T1	3	#10 STRANDED	2TB2	6
11	2T2	25	#14 STRANDED	2TB2	7
12	2T2	26	#14 STRANDED	2TB2	8
13	2TB3	1	#16 STRANDED	2TB2	9
14	2TB3	2	#16 STRANDED	2TB2	10
15	2TB3	3	#16 STRANDED	2TB2	11
16	2TB4	1	#16 STRANDED	2S4	COM
17	2TB4	2	#16 STRANDED	2TB2	13
18	2TB4	3	#16 STRANDED	2TB2	14
19	2TB4	4	#16 STRANDED	2S6	NO
20	2K1	1	#16 STRANDED	2TB2	16
21	2K1	2	#16 STRANDED	2TB2	17
22	2S3	N.O.	#16 STRANDED	2TB2	18
23	2S3	COM	#16 STRANDED	2TB2	19
25	2TB2-23		#16 STRANDED	2A4	E3

Cabinet 2 Cable
817 1494 014-A
(Sheet 1 of 3)

888-2213-001
8-55/8-56

WARNING: Disconnect primary power prior to servicing.

DATE 8-26-3		RUNNING SHEET 817 1494-014		CABLE NO. REV A M	
WIRE NO.	FROM		WIRE SIZE AND TYPE	TO	
	EQUIPMENT	TERMINAL		EQUIPMENT	TERMINAL
30w	2C7	2	#8411 Beldon	2TB2	27
30S	2C7	GND LUG	#8411 Beldon	2TB2	28
31w	2A5	4	#8411 Beldon	2TB2	29
31S	2A5	3	#8411 Beldon	2TB2	30
32	2A5	1	#16 STRANDED	2TB2	16
33	2A5	2	#16 STRANDED	2TB2	17
35	2TB4	9	#16 STRANDED	2S4	NC
36	2S4	COM	#16 STRANDED	2J3	2
37	2TB4	8	#16 STRANDED	2S5	NC
38	2S5	COM	#16 STRANDED	2J3	2
39	2S6	COM	#16 STRANDED	2S7	NO
40	2S7	COM	#16 STRANDED	2TB2	15
41	2S4	NO	#16 STRANDED	2S5	COM
42	2S5	NO	#16 STRANDED	2TB2	12
45	2TB2	24	#12 STRANDED	2TB4	7
46	2TB2	25	#12 STRANDED	2TB4	6

Cabinet 2 Cable
817 1494 014-A
(Sheet 2 of 3)

888-2213-001
8-57/8-58

WARNING: Disconnect primary power prior to servicing.

DATE	8-26-3		RUNNING SHEET	817 1494-014		CABLE NO.	REV A M
WIRE NO.	FROM		WIRE SIZE AND TYPE	TO			
	EQUIPMENT	TERMINAL		EQUIPMENT	TERMINAL		
47	2TB2	26	#12 STRANDED	2TB4	5		
48	2TB4	7	#12 STRANDED	2J3	2		
49	2TB4	6	#12 STRANDED	2J3	1		
50	2TB4	5	#12 STRANDED	2J3	GND		
			JUMPERS				
	2L6	2	#16 STRANDED	2C7	2		
	2C7	2	#16 STRANDED	2E1	1		
	2A4	E1	#12 BROWN TURBO	2C14	1		
	2C14	1	#10 100KW WIRE	2L2	2		
	2L2	1	#10 100KW WIRE	2L1	2		
	2L1	1	#10 100KW WIRE	2C1	1		
	2L7	2	#10 100KW WIRE	2K1	1		
	2K1	2	#10 100KW WIRE	2R14	2		
	TRANSMISSION LINE		#10 100KW WIRE	2L6	1		
	2L2	2	5/16" COPPER TUBING	2L7	2		
	2L2	2	5/16" COPPER TUBING	2C8	2		
	2C8	2	1/2" COPPER TUBING	2C9	2		
	2C9	2	1/2" COPPER TUBING	2C10	2		
	2R14	1	1/2" COPPER TUBING	2R14	GND		

Cabinet 2 Cable
817 1494 014-A
(Sheet 3 of 3)

888-2213-001
8-59/8-60

WARNING: Disconnect primary power prior to servicing.

DATE		RUNNING SHEET		CABLE NO.	
9-26-83		817 1494 022		REV B M	
WIRE NO.	FROM		WIRE SIZE AND TYPE	TO	
	EQUIPMENT	TERMINAL		EQUIPMENT	TERMINAL
1	1TB1	3	#16 STRANDED	3TB1	1
2					
3	1TB1	5	#16 STRANDED	3TB1	3
4	1TB1	6	#16 STRANDED	3TB1	4
5	1TB1	7	#16 STRANDED	3TB1	5
6	1TB1	8	#16 STRANDED	3TB1	6
7					
8W	1TB1	12	8411 BELDON	3TB1	8
8S	1TB1	13	8411 BELDDN	3TB1	9
9					
10	1TB1	1	#16 STRANDED	3TB1	10
11	1TB1	2	#16 STRANDED	3TB1	11
12	3K1	3	#16 STRANDED	3K3	1
13	3K3	2	#16 STRANDED	3K4	1
14	3TB1	1	#16 STRANDED	3K2	2
15	3K1	4	#16 STRANDED	3K2	1
16	3TB1	3	#16 STRANDED	3K1	1
17	3TB1	4	#16 STRANDED	3K5	2
18	3TB1	5	#16 STRANDED	3K2	13
19	3TB1	6	#16 STRANDED	3K2	14
20	3K4	7	#16 STRANDED	3K5	1
21W	3TB1	8	8411 BELDEN	3K2	11
21S	3TB1	9	8411 BELDEN	3K2	12
22	3K1	3	#16 STRANDED	3K1	2
23	3K2	3	#6 STRANDED	3K1	6
24	3K2	5	#6 STRANDED	3K1	8

Step-Start
817 1494 022-B
(Sheet 1 of 2)

888-2213-001
8-61/8-62

WARNING: Disconnect primary power prior to servicing.

DATE		RUNNING SHEET		CABLE NO.	
7-17-74		816-6338-001		927-9991-001	
WIRE NO.	FROM		WIRE SIZE AND TYPE	TO	
	EQUIPMENT	TERMINAL		EQUIPMENT	TERMINAL
1*	1TB1	3	#16 STRANDED	3TB1	1
2*					
3*	1TB1	5	#16 STRANDED	3TB1	3
4*	1TB1	6	#16 STRANDED	3TB1	4
5*	1TB1	7	#16 STRANDED	3TB1	5
6*	1TB1	8	#16 STRANDED	3TB1	6
7*					
8W*	1TB1	12	8411 BELDEN	3TB1	8
8S*	1TB1	13	8411 BELDEN	3TB1	9
9*					
10*	1TB1	1	#16 STRANDED	3TB1	10
11*	1TB1	2	#16 STRANDED	3TB1	11
12	3K1	3	#16 STRANDED	3K3	1
13	3K1	2	#16 STRANDED	3K4	1
14	3TB1	1	#16 STRANDED	3K2	2
15	3K1	4	#16 STRANDED	3K2	1
16	3TB1	3	#16 STRANDED	3K1	1
17	3TB1	4	#16 STRANDED	3K5	2
18	3TB1	5	#16 STRANDED	3K2	9
19	3TB1	6	#16 STRANDED	3K2	10
20	3K4	7	#16 STRANDED	3K5	1
21W	3TB1	8	8411 BELDEN	3K2	11
21S	3TB1	9	8411 BELDEN	3K2	12
22	3K1	3	#16 STRANDED	3K1	2
			(*) NOT IN CABLE		

External
816 6338 001-C1
(Sheet 1 of 2)

888-2213-001
8-67/8-68

WARNING: Disconnect primary power prior to servicing.

DATE 3-21-85		RUNNING SHEET 817 1494 054		CABLE NO. REV	
WIRE NO.	FROM		WIRE SIZE AND TYPE	TO	
	EQUIPMENT	TERMINAL		EQUIPMENT	TERMINAL
1	1TB4	1	#16 STRANDED	1A11A1	
2	1TB4	2	#16 STRANDED	1A11A1	E18
3	1TB4	3	#16 STRANDED	1A11A1	E15
4	1TB4	4	#16 STRANDED	1A11A1	E9
5	1TB4	5	#16 STRANDED	1A11A1	E2
6	1TB4	6	#16 STRANDED	1A11A1	E20
7	1TB4	7	#16 STRANDED	1A11A1	E4
8	1TB4	8	#16 STRANDED	1A11A1	E10
9	1TB4	9	#16 STRANDED	1A11A1	E11
10	1TB4	10	#16 STRANDED	1A11A1	E9
11	1TB4	11	#16 STRANDED	1A11A1	E12
12	1TB4	12	#16 STRANDED	1A11A1	E1
13	1TB4	13	#16 STRANDED	1A11A1	E5
14	1TB4	14	#16 STRANDED	1A11A1	E6
15	1TB4	15	#16 STRANDED	1A11A1	E3
16	1TB4	16	#16 STRANDED	1A11A1	E8
17	1TB4	17	#16 STRANDED	1A11A1	E13
18	1TB4	18	#16 STRANDED	1A11A1	E14
19	1TB4	19	#16 STRANDED	1A11A1	E16
20	1TB4	20	#16 STRANDED	1A16	E1
21	1TB4	21	#16 STRANDED	1A16	E2
22	1TB4	22	#16 STRANDED	1M6	+
23	1TB4	23	#16 STRANDED	1R56	
24	1TB4	24	#14 STRANDED	1M5	-
25	1TB4	25	#14 STRANDED	1M5	+
26W	1TB4	26	#8411 BELDEN	1R61	1

Meter and Switch Cable
817 1494 054-A
(Sheet 1 of 3)

888-2213-001
8-71/8-72

WARNING: Disconnect primary power prior to servicing.

DATE		RUNNING SHEET		CABLE NO.	
3-21-85		817 1494 054		REV	
WIRE NO.	FROM		WIRE SIZE AND TYPE	TO	
	EQUIPMENT	TERMINAL		EQUIPMENT	TERMINAL
26S			#8411 BELDEN	1M4	E1
27	1TB4	27	#12 STRANDED	1J3	GND
28	1TB4	28	#12 STRANDED	1J3	1
29	1TB4	29	#12 STRANDED	1J3	2
30	1A11A1	E17	#16 STRANDED	1M5	+
31	1M6	+	#16 STRANDED	1M4	-
32	1M3	+	#16 STRANDED	1A11S1	1
33	1M3	-	#16 STRANDED	1A11S1	GND
34	1M3	-	#16 STRANDED	1M4	E1
40W	1TB4	30	8411 BELDEN	1TB10	5
40S	1TB4	31	8411 BELDEN	1TB10	6
41W	1TB4	32	8411 BELDEN	1TB10	7
41S	1TB4	33	8411 BELDEN	1TB10	8
42R	1TB4	34	8451 BELDEN	1TB8	3
42B	1TB4	35	8451 BELDEN	1TB8	2
42S	1TB4	36	8451 BELDEN	1TB8	1
43W	1TB10	1	8451 BELDEN	1A11S1	4
43S	1TB10	2	8451 BELDEN	1A11S1	GND
44W	1TB10	3	8451 BELDEN	1A11S1	3
44S	1TB10	4	8451 BELDEN	1A11S1	GND
45W	1A2TB1	9	8411 BELDEN	2A3	E2

Meter and Switch Cable
817 1494 054-A
(Sheet 2 of 3)

888-2213-001
8-73/8-74

WARNING: Disconnect primary power prior to servicing.

DATE 8-24-83		RUNNING SHEET 817 1494 013		CABLE NO. <i>Rev A M</i>	
WIRE NO.	FROM		WIRE SIZE AND TYPE	TO	
	EQUIPMENT	TERMINAL		EQUIPMENT	TERMINAL
1	2TB4	3	16 STRANDED	2A3S1	NO
2	2TB4	4	16 STRANDED	2A3S2	COM
3	2TB4	1	16 STRANDED	2S1A	NO
4	2TB4	2	16 STRANDED	2S2A	COM
5	2S1A	COM	16 STRANDED	2S2A	NO
6	2AS1	COM	16 STRANDED	2A3S2	NO
17	2TB4	5	12 STRANDED	2J2	GND
8	2TB4	6	12 STRANDED	2J2	1
9	2TB4	7	12 STRANDED	2J2	2
10	2TB4	8	16 STRANDED	2S2B	NC
11	2TB4	9	16 STRANDED	2S1B	NC
12	2J2	1	16 STRANDED	2TB7	2
13	2J2	2	16 STRANDED	2S1B	COM
14	2J2	2	16 STRANDED	2S2B	COM
15	2TB4	8	16 STRANDED	2TB7	1
16	2TB4	9	16 STRANDED	2TB7	3
17	2TB7	1	16 STRANDED	2TB6	1
18	2TB7	3	16 STRANDED	2TB6	3
19	2TB7	4	16 STRANDED	2TB6	4
20	2TB7	4	16 STRANDED	2TB7	2
21	2TB6	4	16 STRANDED	2TB6	2

Cabinet 2 Interlock Output
817 1494 013-A

888-2213-001
8-79/8-80

WARNING: Disconnect primary power prior to servicing.

DATE 3-21-85		RUNNING SHEET 817-1494-053		CABLE NO. REV	
WIRE NO.	FROM		WIRE SIZE AND TYPE	TO	
	EQUIPMENT	TERMINAL		EQUIPMENT	TERMINAL
1	2TB1	1	#6 STRANDED	2T2	2
2	2TB1	2	#6 STRANDED	2T2	9
3	2TB1	3	#6 STRANDED	2T2	16
4	2TB1	4	#6 STRANDED	GND	STUD
5	2T2	22	#6 STRANDED	2TB2	1
6	2T2	23	#6 STRANDED	2TB2	2
7	2T2	24	#6 STRANDED	2TB2	3
8	2E2	1	#10 STRANDED	2TB2	4
9	2T1	1	#10 STRANDED	2TB2	5
10	2T1	3	#10 STRANDED	2TB2	6
11	2T2	25	#14 STRANDED	2TB2	7
12	2T2	26	#14 STRANDED	2TB2	8
13	2TB3	1	#16 STRANDED	2TB2	9
14	2TB3	2	#16 STRANDED	2TB2	10
15	2TB3	3	#16 STRANDED	2TB2	11
16	2TB4	1	#16 STRANDED	2S4	COM
17	2TB4	2	#16 STRANDED	2TB2	13
18	2TB4	3	#16 STRANDED	2TB2	14
19	2TB4	4	#16 STRANDED	2S6	NO
20	2K1	1	#16 STRANDED	2TB2	16
21	2K1	2	#16 STRANDED	2TB2	17
22	2S3	N.O.	#16 STRANDED	2TB2	18
23	2S3	COM	#16 STRANDED	2TB2	19
25W	2TB2	23	#8411 BELDEN	2A4	E3
25S	2TB2	22	#8411 BELDEN		
26	2TB2	22	#16 STRANDED	GND	STUD

Cabinet 2 Cable (Output)
817 1494 053
(Sheet 1 of 3)

888-2213-001
8-81/8-82

WARNING: Disconnect primary power prior to servicing.

DATE 3-21-85		RUNNING SHEET 817-1494-053		CABLE NO. REV	
WIRE NO.	FROM		WIRE SIZE AND TYPE	TO	
	EQUIPMENT	TERMINAL		EQUIPMENT	TERMINAL
30W	2C7	2	#8411 BELDEN	2TB2	27
30S	2C7	GND LUG	#8411 BELDEN	2TB2	28
31W	2A5	4	#8411 BELDEN	2TB2	29
31S	2A5	3	#8411 BELDEN	2TB2	30
32	2A5	1	#16 STRANDED	2TB2	16
33	2A5	2	#16 STRANDED	2TB2	17
35	2TB4	9	#16 STRANDED	2S4	NC
36	2S4	COM	#16 STRANDED	2J3	2
37	2TB4	8	#16 STRANDED	2S5	NC
38	2S5	COM	#16 STRANDED	2J3	2
39	2S6	COM	#16 STRANDED	2S7	NO
40	2S7	COM	#16 STRANDED	2TB2	15
41	2S4	NO	#16 STRANDED	2S5	COM
42	2S5	NO	#16 STRANDED	2TB2	12
45	2TB2	24	#12 STRANDED	2TB4	7
46	2TB2	25	#12 STRANDED	2TB4	6

Cabinet 2 Cable (Output)
817 1494 053
(Sheet 2 of 3)

888-2213-001
8-83/8-84

WARNING: Disconnect primary power prior to servicing.

DATE 3-27-85		RUNNING SHEET 817-1494-053		CABLE NO. REV	
WIRE NO.	FROM		WIRE SIZE AND TYPE	TO	
	EQUIPMENT	TERMINAL		EQUIPMENT	TERMINAL
47	2TB2	26	#12 STRANDED	2TB4	5
48	2TB4	7	#12 STRANDED	2J3	2
49	2TB4	6	#12 STRANDED	2J3	1
50	2TB4	5	#12 STRANDED	2J3	GND
			JUMPERS		
	2L6	2	#16 STRANDED	2C7	2
	2C7	2	#16 STRANDED	2E1	1
	2A4	E1	#12 BROWN TURBO	2C14	1
	2C14	1	#10 100KW WIRE	2L2	2
	2L2	1	#10 100KW WIRE	2L1	2
	2L1	1	#10 100KW WIRE	2C1	1
	2L7	2	#10 100KW WIRE	2K1	1
	2K1	2	#10 100KW WIRE	2R14	2
	TRANSMISSION LINE		#10 100KW WIRE	2L6	1
	2L2	2	5/16" COPPER TUBING	2L7	2
	2L2	2	5/16" COPPER TUBING	2C8	2
	2C8	2	1/2" COPPER TUBING	2C9	2
	2C9	2	1/2" COPPER TUBING	2C10	2
	2R14	1	1/2" COPPER TUBING	2R14	GND

Cabinet 2 Cable (Output)
817 1494 053
(Sheet 3 of 3)

888-2213-001
8-85/8-86

WARNING: Disconnect primary power prior to servicing.

SECTION IX

DIAGRAMS

9-1. INTRODUCTION

9-2. This section provides schematic, interconnection, and wiring diagrams necessary for maintaining the HARRIS MW-50C3 MEDIUM WAVE AM BROADCAST TRANSMITTER. The following diagrams are contained in this section.

<u>Figure</u>	<u>Title</u>	<u>Drawing No.</u>	<u>Page</u>
9-1	Overall Schematic - MW-50C3	852 9113 001	9-3/9-4
9-2	PDM Modulator	839 6587 164	9-5/9-6
9-3	Output Network	839 6587 163	9-7/9-8
9-4	RF Amplifier Isolated Enclosure	839 6587 161	9-9/9-10
9-5	RF Oscillator 1A10	839 6587 040	9-11/9-12
9-6	PDM Chassis/Audio Board (Sheet 1 of 2)	839 6587 152	9-13/9-14
9-6	PDM Chassis/Audio Board (Sheet 2 of 2)	839 6587 152	9-15/9-16
9-7	Fault and Overload Circuit	839 6587 154	9-17/9-18
9-8	Remote Plate Current Sensor	829 2756 001	9-19/9-20
9-9	PA Arc Detector	815 5021 001	9-21/9-22
9-10	Directional Coupler	829 1718 001	9-23/9-24
9-11	Modulation Enhancer	839 1066 001	9-25/9-26
9-12	Utility Outlets and Lights	839 7293 001	9-27/9-28
9-13	Frequency Determining Components	843 4209 111	9-29/9-30

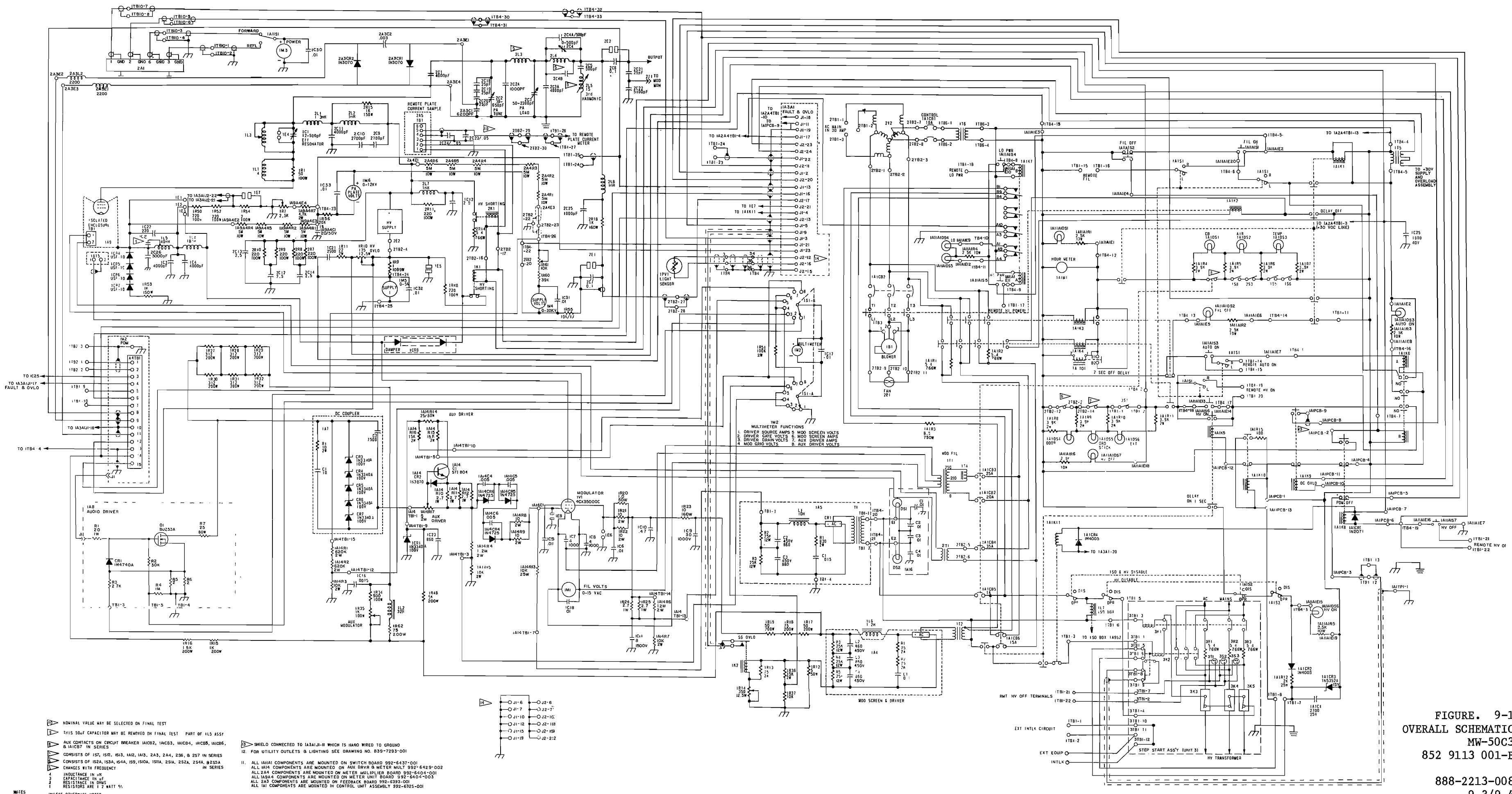
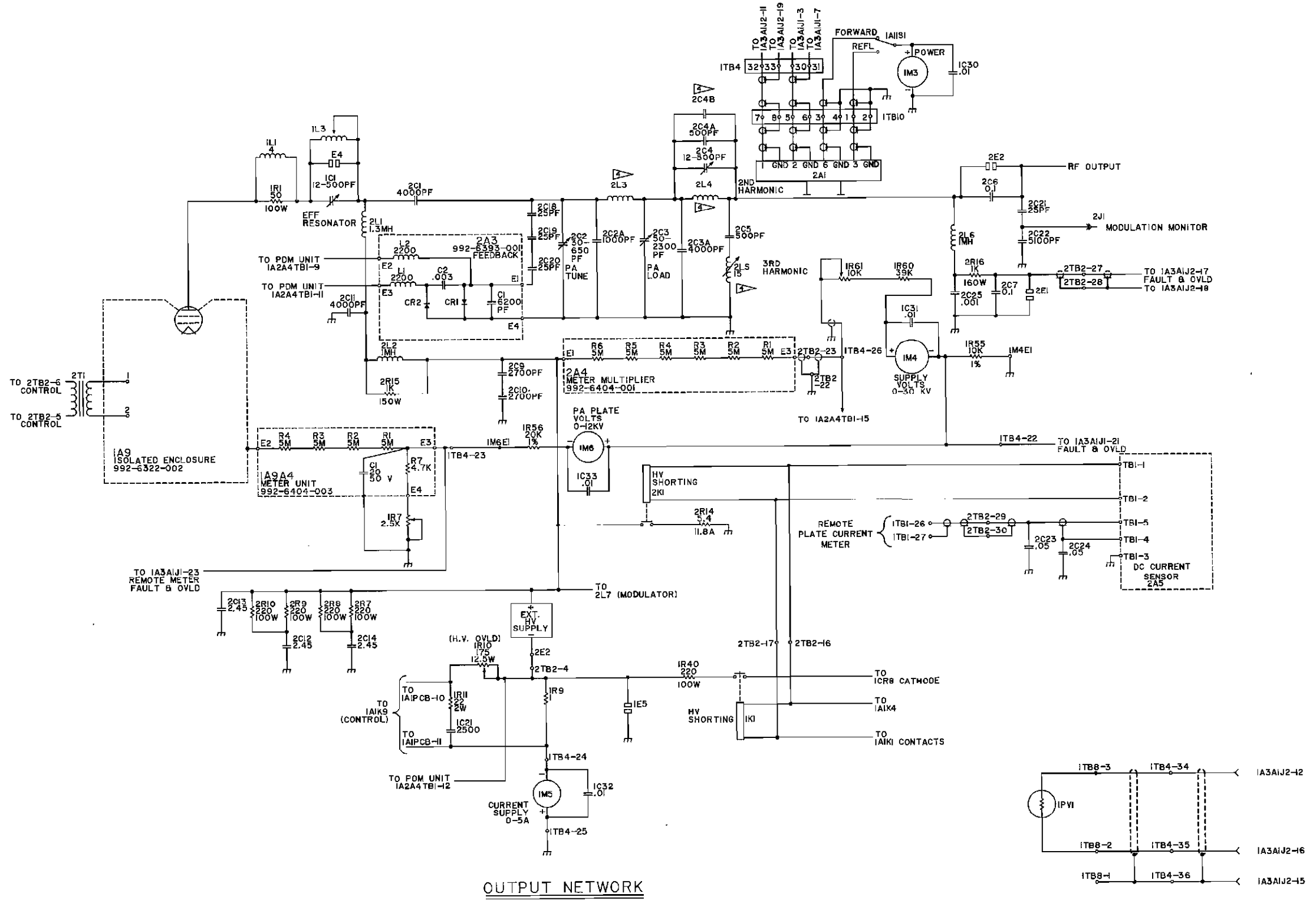

FIGURE 9-1
 OVERALL SCHEMATIC
 MW-50C3
 852 9113 001-B
 888-2213-008
 9-3/9-4

- 1. NOMINAL VALUE MAY BE SELECTED ON FINAL TEST
- 2. THIS 50uf CAPACITOR MAY BE REMOVED ON FINAL TEST PART OF 1L5 ASST
- 3. AUX CONTACTS ON CIRCUIT BREAKER IACB2, IACB3, IACB4, IACB5, IACB6, & IACB7 IN SERIES
- 4. CONSISTS OF 1S7, 1S2, 1S3, 1A2, 1A3, 2A3, 2A4, 2S6, & 2S7 IN SERIES
- 5. CONSISTS OF 1S2A, 1S3A, 1S4A, 1S5, 1S10A, 1S11A, 2S1A, 2S2A, 2S4A, & 2S5A CHANGES WITH FREQUENCY
- 6. INDUCTANCE IN μ H
- 7. CAPACITANCE IN μ F
- 8. RESISTANCE IN OHMS
- 9. RESISTORS ARE 1/2 WATT UNLESS OTHERWISE NOTED
- 10. SHIELD CONNECTED TO IASAJI-11 WHICH IS HARD WIRED TO GROUND
- 11. FOR UTILITY OUTLETS & LIGHTING SEE DRAWING NO. B39-7293-001
- 12. ALL IAI41 COMPONENTS ARE MOUNTED ON SWITCH BOARD 992-6437-001
- 13. ALL IAI42 COMPONENTS ARE MOUNTED ON AUX DRVVR & METER MULT 992-6429-002
- 14. ALL IAI43 COMPONENTS ARE MOUNTED ON METER MULTIPLIER BOARD 992-6404-001
- 15. ALL IAI44 COMPONENTS ARE MOUNTED ON METER UNIT BOARD 992-6404-003
- 16. ALL IAI45 COMPONENTS ARE MOUNTED ON FEEDBACK BOARD 992-6393-001
- 17. ALL IAI COMPONENTS ARE MOUNTED IN CONTROL UNIT ASSEMBLY 992-6325-001



OUTPUT NETWORK

- 5. 2A3CR1 & CR2 ARE IN3070
- ▷ CHANGES WITH FREQUENCY
- 3. INDUCTANCE IS IN UH
- 2. CAPACITANCE IS IN UF
- 1. RESISTORS ARE IN OHMS, 1/2 WATT, 5% UNLESS OTHERWISE NOTED:

FIGURE 9-3. OUTPUT NETWORK
839 6587 163

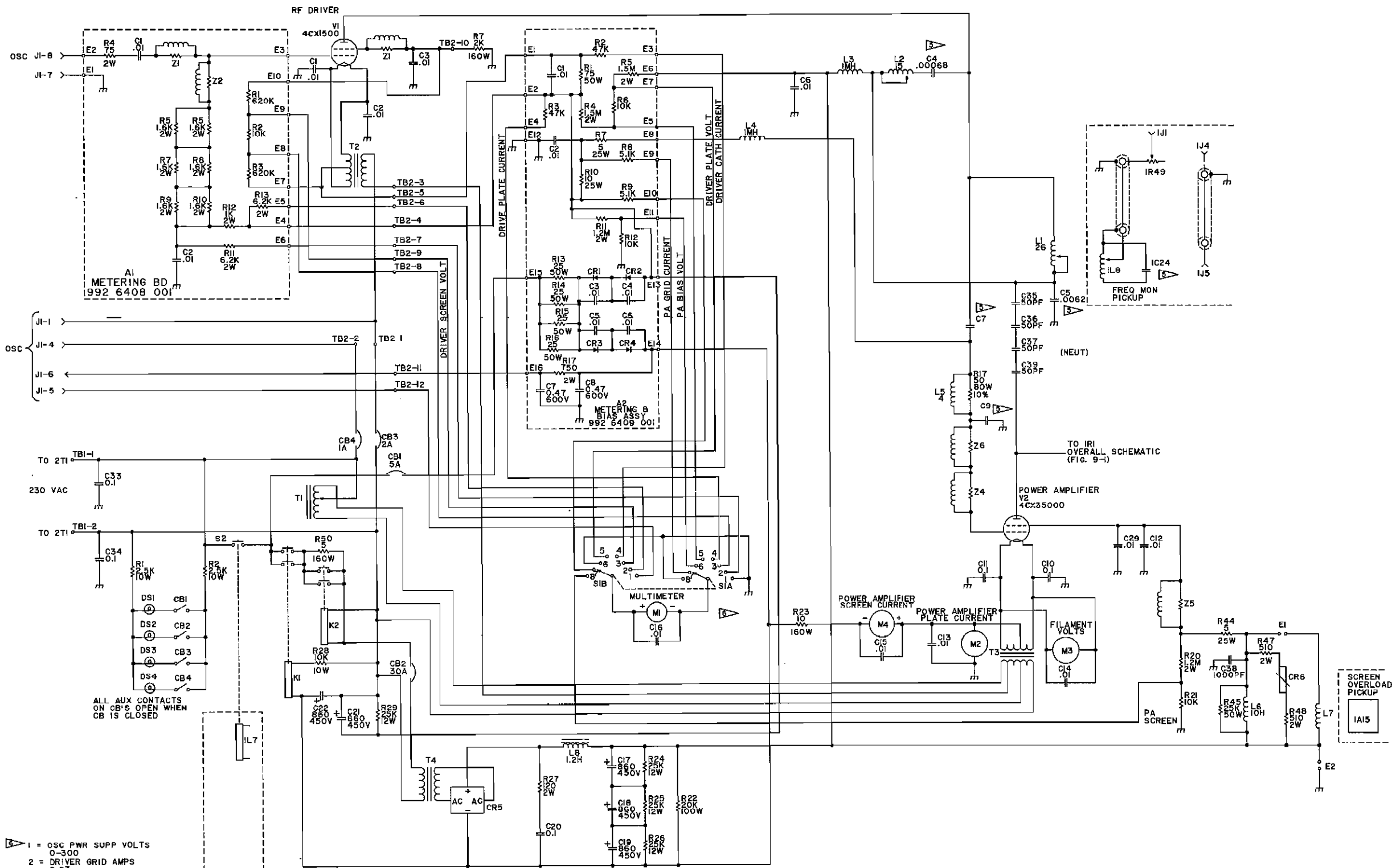

- 1 = OSC PWR SUPP VOLTS
0-300
 - 2 = DRIVER GRID AMPS
0-0.5
 - 3 = DRIVER SCREEN VOLTS
0-1200
 - 4 = DRIVER CATHODE AMPS
0-1.2
 - 5 = DRIVER PLATE VOLTS
0-3000
 - 6 = PWR AMPL BIAS VOLTS
0-1200
 - 7 = PA GRID AMPS
0-1.2
 - 8 = PWR AMPL SCREEN VOLTS
0-1200
- ▲ FREQUENCY DETERMINED COMPONENT
- 4. INDUCTANCE IS IN UH
 - 3. A2CR1-A2CR4 = IN4725
CR5 = PIV
CR6 = VS10LA80A
 - 2. CAPACITANCE IS IN UF
 - 1. RESISTORS ARE IN OHMS, 1/2 WATT, 5%
UNLESS OTHERWISE NOTED:

FIGURE 9-4. RF AMPLIFIER ISOLATED ENCLOSURE
839 6587 161-B

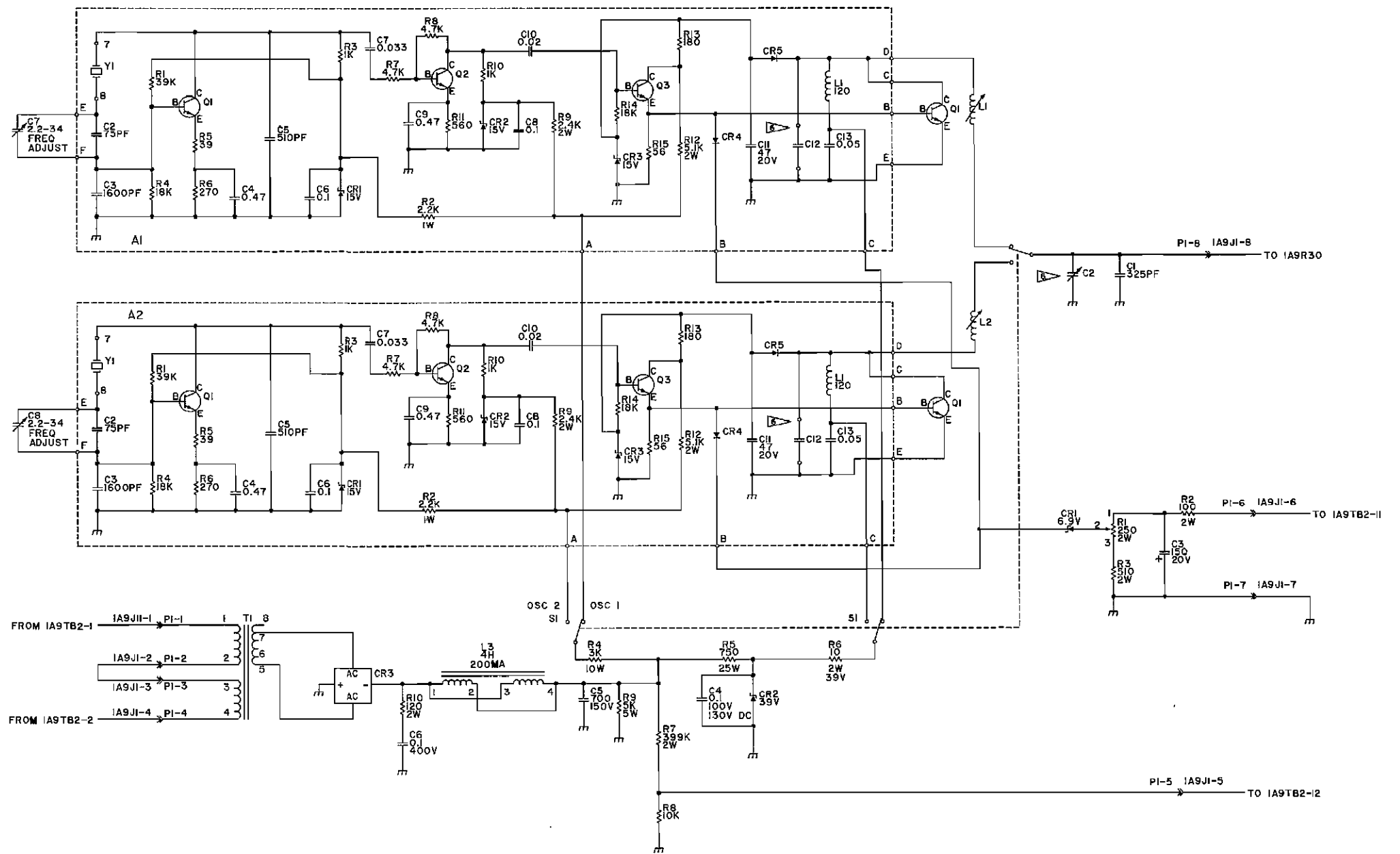

FIGURE 9-5. RF OSCILLATOR 1A10
839 6587 040

▷ FREQUENCY DETERMINED COMPONENT

- 5. A1Q1, A1Q2, A1Q3, A2Q1, A2Q2, A2Q3 = 2N2369
Q1, Q2 = D44C11
- 4. A1CR1, A1CR2, A1CR3, A2CR1, A2CR2, A2CR3 = IN4744
A1CR4, A1CR5, A2CR4, A2CR5 = IN914
CR1 = IN4736
CR2 = IN2992B
CR3 = 18DB8A
- 3. INDUCTANCE IS IN UH
- 2. CAPACITANCE IS IN UF
- 1. RESISTORS ARE IN OHMS, 1/2 WATT, 5%
UNLESS OTHERWISE NOTED.

888-2213-001
9-11/9-12

E

E

D

D

C

C

B

B

A

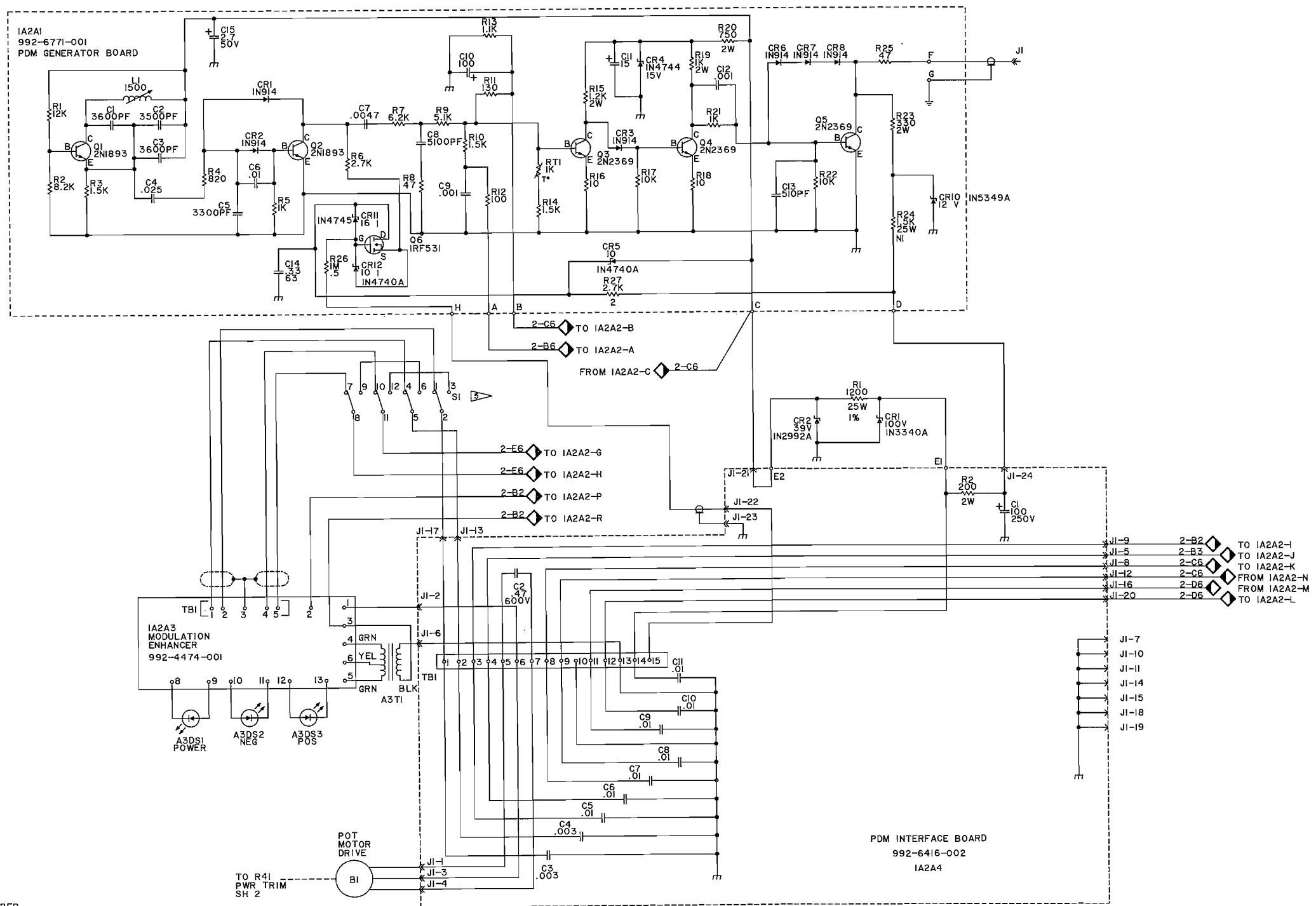

6. INDICATES SHEET NUMBER (UNUSED IF SAME SHEET)
 INDICATES ZONE
 CONTINUATION SYMBOL

- ▶ SI SHOWN IN ENHANCE POSITION.
- 4. ALL RESISTORS ARE 1/2 WATT 5%
- 3. INDUCTANCE IN UH.
- 2. CAPACITANCE IN UF.
- 1. RESISTANCE IN OHMS.
- UNLESS OTHERWISE NOTED:

FIGURE 9-6. PDM CHASSIS/AUDIO BOARD
 (Sheet 1 of 2)
 839 6587 152-A

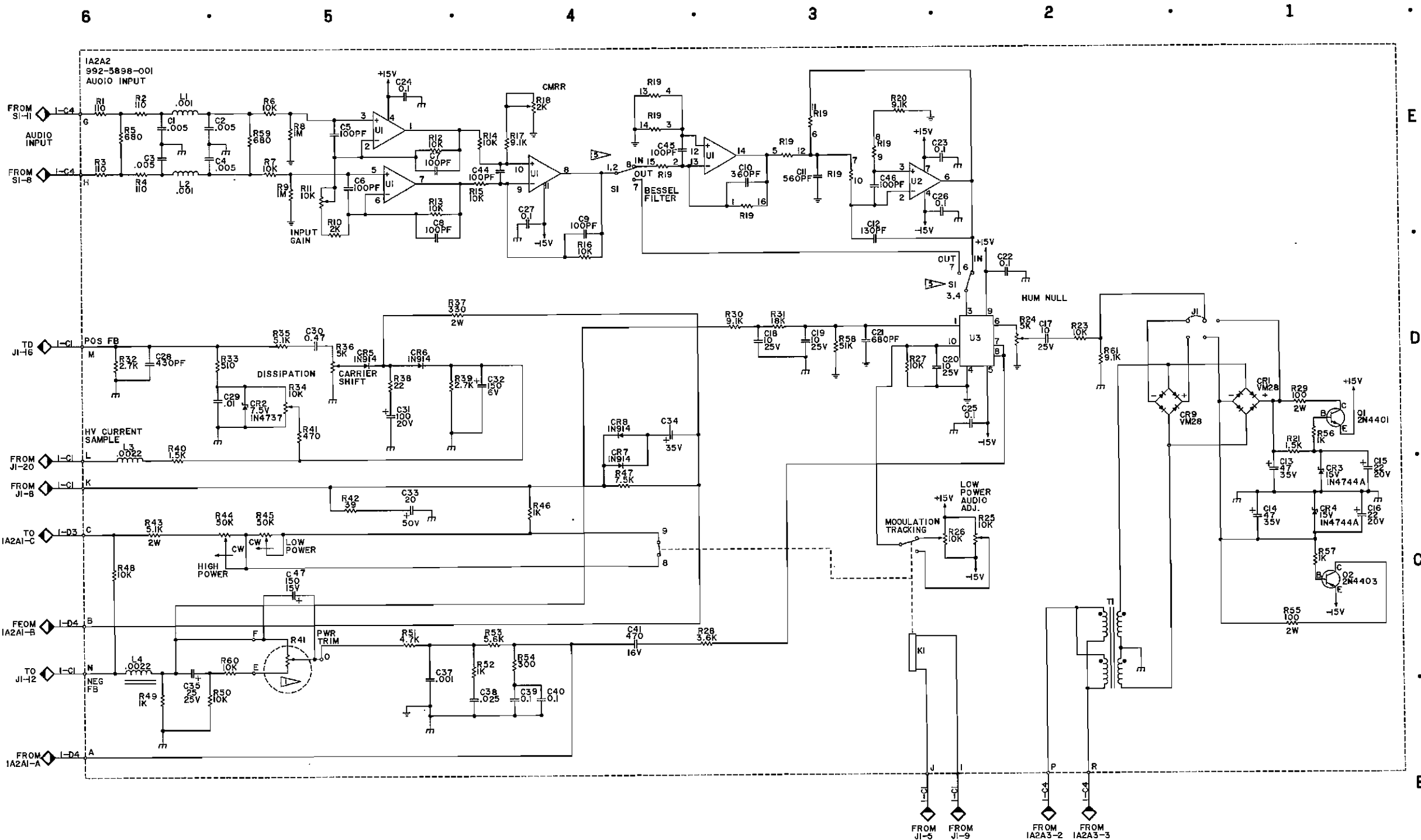

3. IC IDENTIFICATION:
 U1 - TL074CN3
 U2 - TL074CP3
 U3 - AD534JH

2. RESISTORS ARE 1/4 WATT 5%

NOT DN BOARD, PART OF POT MOTOR DRIVE.
 UNLESS OTHERWISE NOTED

FIGURE 9-6. PDM CHASSIS/AUDIO BOARD
 (Sheet 2 of 2)
 839 6587 152-C

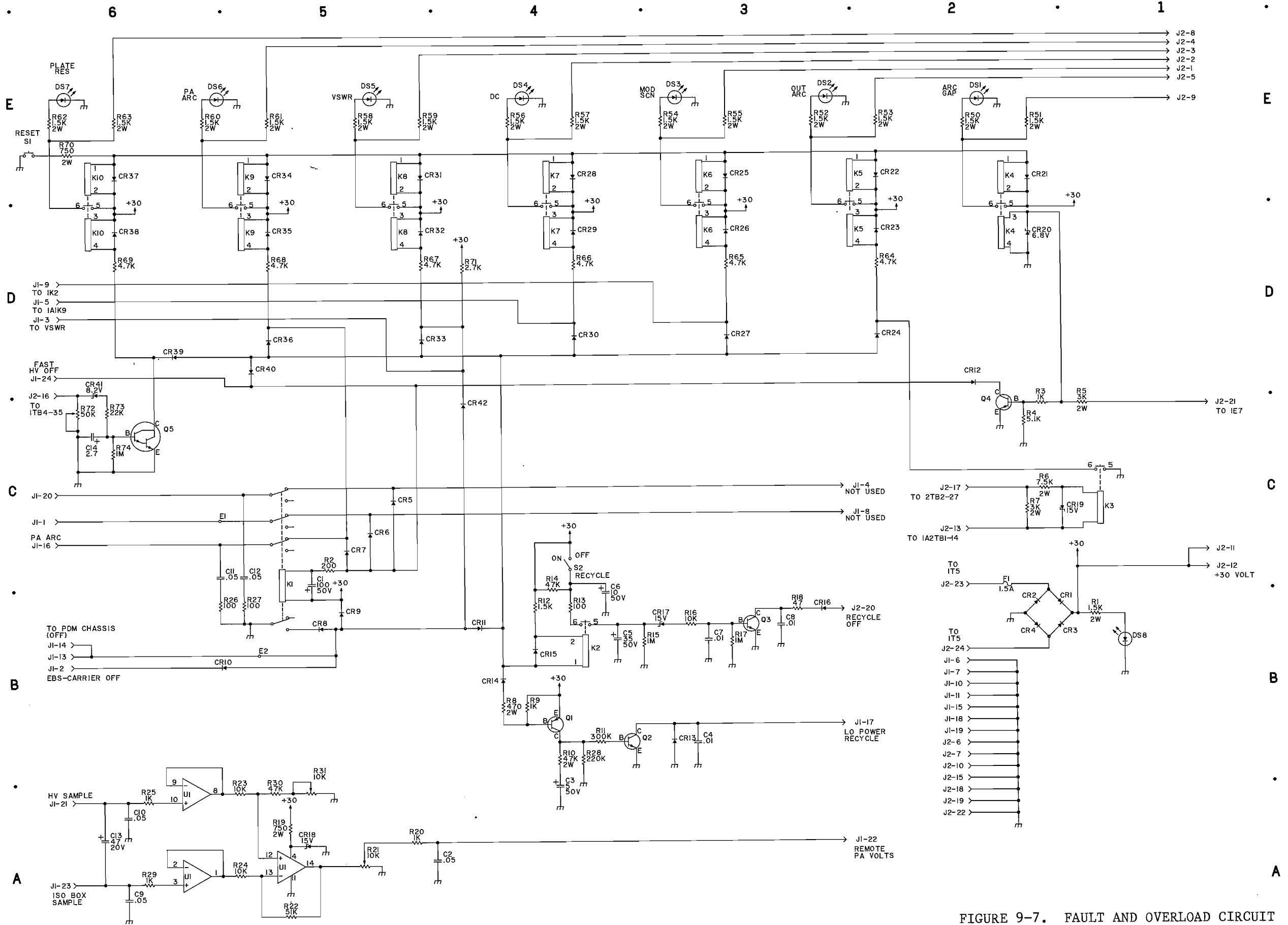

FIGURE 9-7. FAULT AND OVERLOAD CIRCUIT
839 6587 154

2. RESISTORS ARE IN OHMS, 1/2 WATT, 5%
1. CAPACITANCE IS IN UF
UNLESS OTHERWISE NOTED:

3. CR1-CR16, CR21-CR40, CR42 = IN4005
CR17 = IN4744A
CR18-CR19 = IN5352A
CR20 = IN5342
CR41 = IN4738

5. UI = LM324N
4. Q1 = D45CB
Q2, Q3 = MPS-U45
Q4 = D44CB
Q5 = D40CS

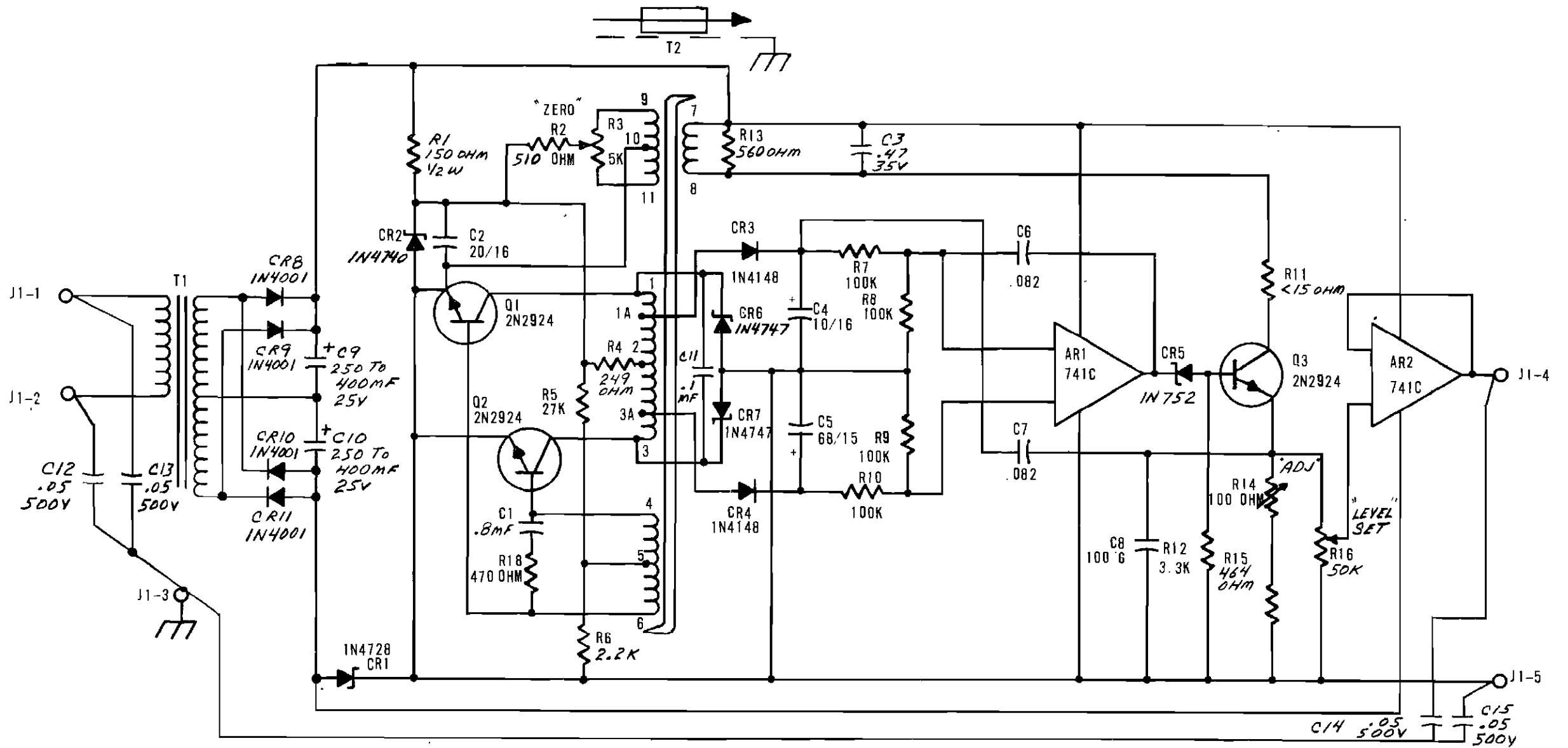

FIGURE 9-8. REMOTE PLATE CURRENT SENSOR
829 2756 001

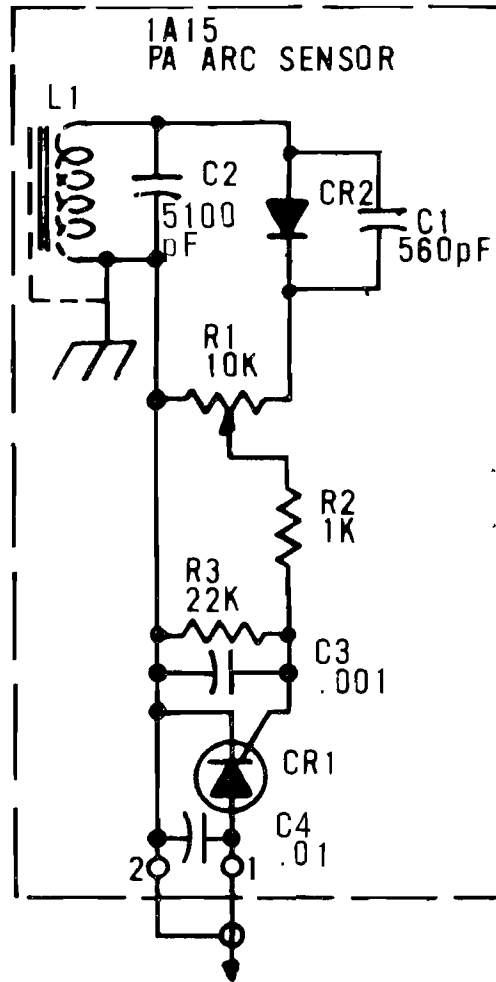
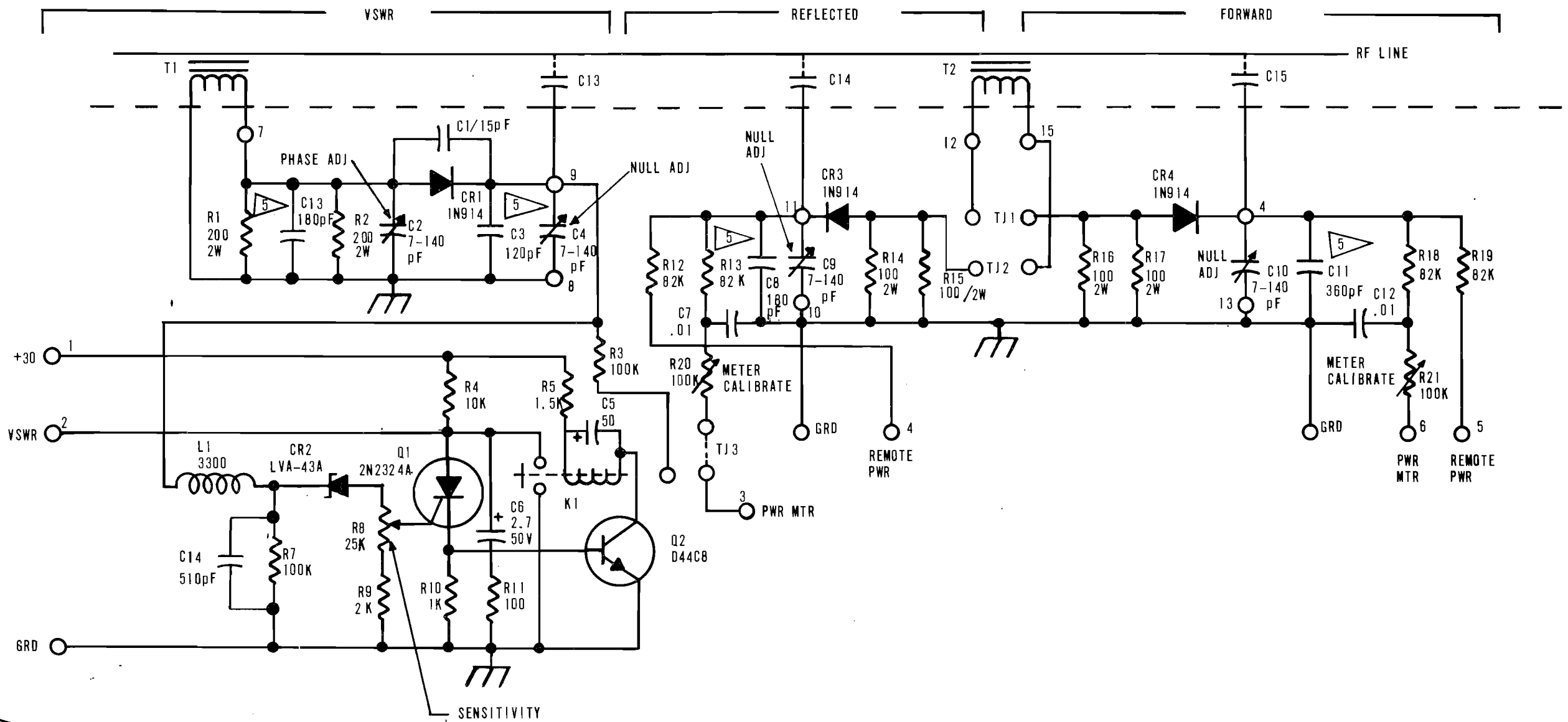

FIGURE 9-9. PA ARC DETECTOR
815 5021 001-B

888-2213-001
9-21/9-22

WARNING: Disconnect primary power prior to servicing.



5 NOMINAL VALUES: MAY BE CHANGED IN FINAL TEST

- 4. INDUCTANCE IN μ H
- 3. CAPACITANCE IN μ F
- 2. RESISTANCE IN OHMS
- 1. RESISTORS ARE 1/2 WATT 5%

UNLESS OTHERWISE NOTED:

FIGURE 9-10. DIRECTIONAL COUPLER
829 1718 001-B

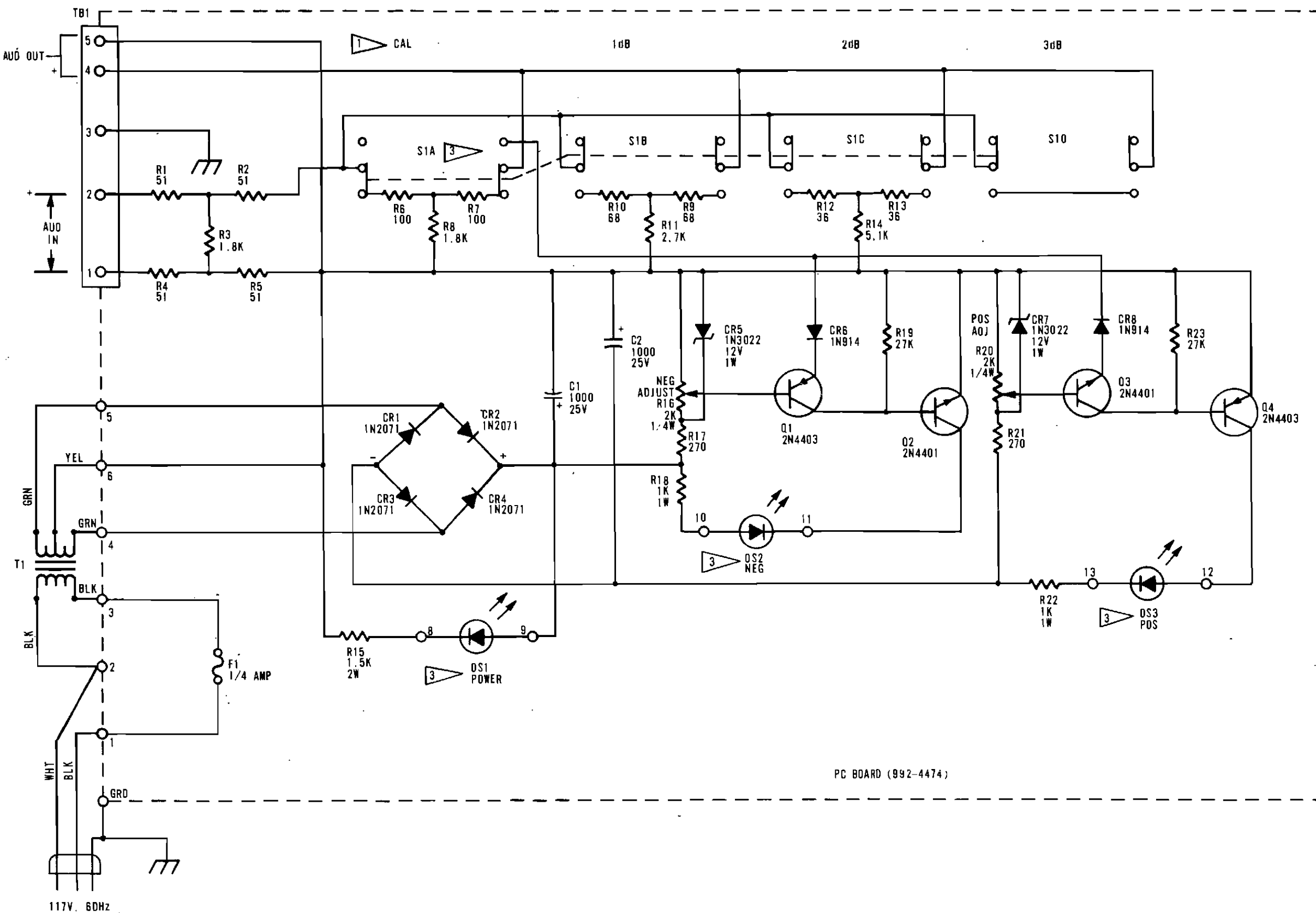

PC BOARD (992-4474)

2 TERM 2 IS + INPUT FRDM LIMITER
 4 TERM 4 IS + INPUT TO THE TRANSMITTER
 1 SWITCH IS SHOWN IN CAL POSITION

5 ALL CAPACITORS 1 WATT MICROFARADS UNLESS NOTED
 4 ALL RESISTORS 1/2 WATT UNLESS NOTES
 3 COMPONENT MOUNTED ON FRONT PANEL

FIGURE 9-11. MODULATION ENHANCER
 839 1066 001-C

888-2213-001
 9-25/9-26

6

5

4

3

2

1

D

D

C

C

B

B

A

A

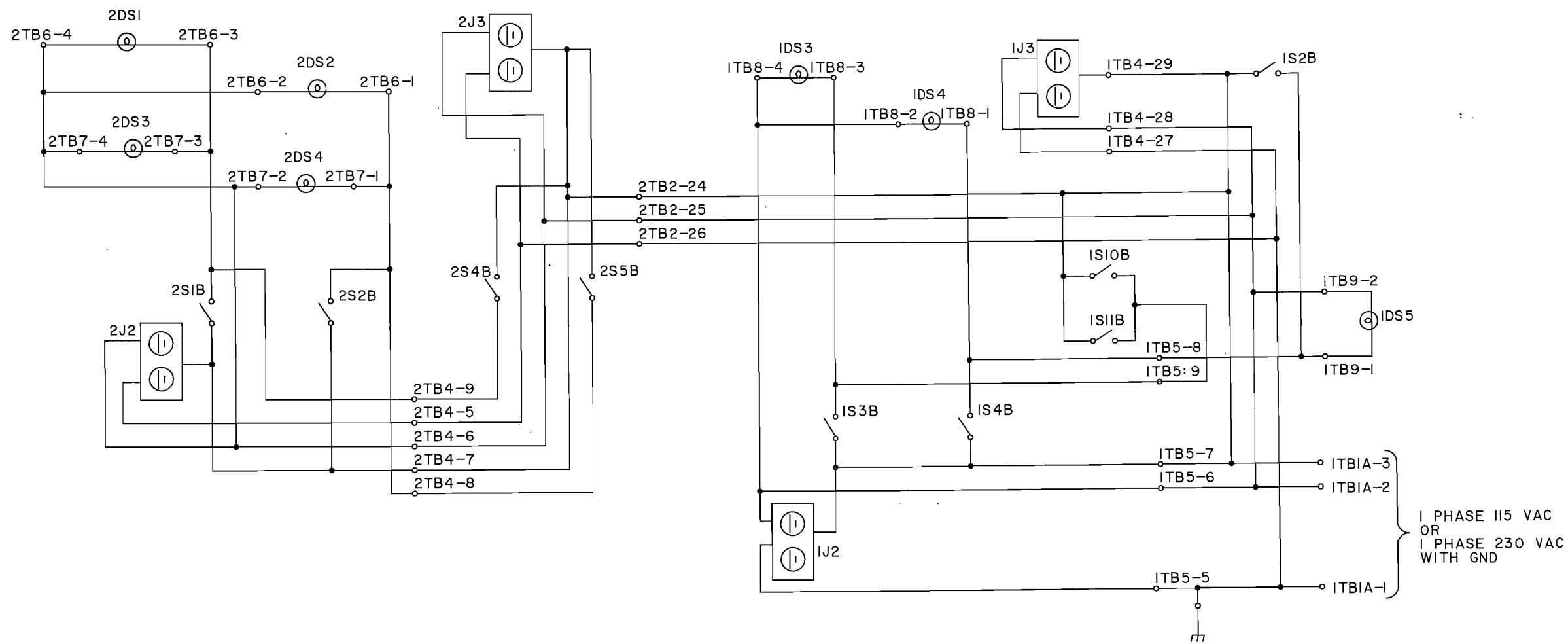

FIGURE 9-12. UTILITY OUTLETS AND LIGHTS
839 7293 001

I. THE AC SOURCE FOR UTILITY OUTLETS AND LIGHTS MUST BE SEPARATE FROM ANY TRANSMITTER CONTROL AC SERVICES.

888-2213-001
9-27/9-28

FREQ KHZ	CABINET 2								ISOLATED BOX (IA9)				CABINET 1							
	PA TANK 2L3		OUTPUT 2L4	3RD HARMONIC 2L5		2ND HARMONIC 2C4B	FLANGE FOR 2C4B	BRACKET FOR 2C4B	BRACKET FOR 2C4B	C4	C5	C7	C9	IC24	IA10C2A	IA10C2	IA10A1C12	IA10A2C12	TUBE CONN. IA9C4 TO IA9L2	STRAP
540	22 TURNS	992 3511 022	992 6445 001	21 TURNS	943 3777 012	512 0053 000	530 0002 000	839 1950 001	839 1950 002	504 0374 000 .002	504 0413 000 .012	504 0372 000 .0056	504 0239 000 .0022	500 0759 000 100PF	500 0842 000	500 0852 000 1000PF	500 0846 000 8200PF	500 0846 000 8200PF	829 1769 001	829 9468 059
600	18 TURNS	992 3511 018		↓	↓	↓	↓	↓	↓	↓	↓	↓	↓	↓	↓	↓	↓	↓	↓	↓
650	↓	↓	↓	14 TURNS	943 3777 002	NOT USED	NOT USED	NOT USED	NOT USED	504 0373 000 .0012	504 0365 000 .0062	504 0242 000 .0036	504 0256 000 .001	500 0821 000 58PF	NOT USED	↓	↓	↓	829 1769 002	↓
700	↓	↓	↓	↓	↓	↓	↓	↓	↓	↓	↓	↓	↓	↓	↓	↓	↓	↓	↓	↓
750	16 TURNS	992 3511 016	↓	↓	↓	↓	↓	↓	↓	↓	↓	↓	↓	↓	↓	↓	↓	↓	↓	↓
800	14 TURNS	992 3511 014	↓	↓	↓	↓	↓	↓	↓	↓	↓	↓	↓	↓	↓	↓	500 0882 000 3600PF	500 0882 000 3600PF	↓	NOT USED
850	↓	↓	↓	↓	↓	↓	↓	↓	↓	↓	↓	↓	↓	↓	↓	↓	↓	↓	↓	↓
900	12 TURNS	992 3511 012	↓	↓	↓	↓	↓	↓	↓	↓	↓	↓	↓	↓	↓	↓	↓	↓	↓	↓
950	↓	↓	↓	↓	↓	↓	↓	↓	↓	↓	↓	↓	↓	↓	↓	↓	↓	↓	↓	↓
1000	9 TURNS	992 3511 009	992 6444 001	↓	↓	↓	↓	↓	↓	504 0264 000 .00068	504 0412 000 .0043	504 0239 000 .0022	504 0367 000 .00056	500 0813 000 33PF	↓	500 0835 000 470PF	↓	↓	↓	↓
1050	↓	↓	↓	↓	↓	↓	↓	↓	↓	↓	↓	↓	↓	↓	↓	↓	↓	↓	↓	↓
1100	↓	↓	↓	↓	↓	↓	↓	↓	↓	↓	↓	↓	↓	↓	↓	↓	↓	↓	↓	↓
1150	↓	↓	↓	↓	↓	↓	↓	↓	↓	↓	↓	↓	↓	↓	↓	↓	↓	↓	↓	↓
1200	↓	↓	↓	↓	↓	↓	↓	↓	↓	↓	↓	↓	↓	↓	↓	↓	↓	↓	↓	↓
1250	↓	↓	↓	↓	↓	↓	↓	↓	↓	↓	↓	↓	↓	↓	↓	↓	↓	↓	↓	↓
1300	7 TURNS	992 3511 007	↓	↓	↓	↓	↓	↓	↓	↓	↓	↓	↓	↓	↓	↓	500 0756 000 330PF	500 0966 000 2200	500 0966 000 2200	↓
1350	↓	↓	↓	↓	↓	↓	↓	↓	↓	↓	↓	↓	↓	↓	↓	↓	↓	↓	↓	↓
1400	↓	↓	↓	↓	↓	↓	↓	↓	↓	↓	↓	↓	↓	↓	↓	↓	↓	↓	↓	↓
1450	↓	↓	↓	↓	↓	↓	↓	↓	↓	↓	↓	↓	↓	↓	↓	↓	↓	↓	↓	↓
1500	↓	↓	↓	↓	↓	↓	↓	↓	↓	↓	↓	↓	↓	↓	↓	↓	↓	↓	↓	↓
1550	↓	↓	↓	↓	↓	↓	↓	↓	↓	↓	↓	↓	↓	↓	↓	↓	↓	↓	↓	↓
1600	↓	↓	↓	↓	↓	↓	↓	↓	↓	↓	↓	↓	↓	↓	↓	↓	↓	↓	↓	↓

CABINET 1																				
FREQ KHZ	IC2	IC2 STRAP																		
540	516 0208 000	929 0613 001																		
600	↓	↓																		
650	↓	↓																		
700	↓	↓																		
750	NOT USED	NOT USED																		
800	↓	↓																		
850	↓	↓																		
900	↓	↓																		
950	↓	↓																		
1000	↓	↓																		
1050	↓	↓																		
1100	↓	↓																		
1150	↓	↓																		
1200	↓	↓																		
1250	↓	↓																		
1300	↓	↓																		
1350	↓	↓																		
1400	↓	↓																		
1450	↓	↓																		
1500	↓	↓																		
1550	↓	↓																		
1600	↓	↓																		

FIGURE 9-13. FREQUENCY DETERMINING COMPONENTS
843 4209 111

APPENDIX A

MW-50C3 MEDIUM WAVE AM BROADCAST TRANSMITTER

HV POWER SUPPLIES

APPENDIX A

HV POWER SUPPLIES

A-1. INTRODUCTION

A-2. This appendix contains electrical specifications, parts lists, and simplified schematic diagrams for the following optional HARRIS MW-50C3 MEDIUM WAVE AM BROADCAST TRANSMITTER power supplies.

	<u>PART NO.</u>	<u>PAGE</u>
50KW SUPPLIES:	736-0032-000	A3
	736-0033-000	A4
	736-0084-000	A5
	736-0085-000	A6
	736-0119-000	A7
100 KW SUPPLIES:	736-0038-000	A8

50 KW SUPPLY

Harris Part No.: 736 0032 000

Harris Specification No.: 815 5031 001

Manufacturer: Aydin Energy Systems, No. 2T68, Oil filled transformer, dry rectifiers.

Primary: 440/460/480 V, 3 ϕ , 60 Hz, Delta

Maximum Primary Overvoltage: 5%

Secondary: 24.5 kV at 4 Amperes continuous, 12-phase
(98 kW Maximum)

<u>REF. SYMBOL</u>	<u>HARRIS PART NO.</u>	<u>DESCRIPTION</u>	<u>QTY.</u>
CR1 thru CR3	384 0386 000	Rectifier Stack, IR 1HQ10K16A	3
T1		High Voltage Transformer, Energy Systems 1B86	1
C1 thru C3	510 0638 000	Power Factor Correction Capacitor, 30 uF, 500 Vac	3
C4,C5	510 0568 000	Surge Suppression Capacitor 2 0.02 uF, +20%, 30 kV	2
R1,R2	542 0354 000	Surge Suppression Resistor, 2 50 ohms, +5%, 225 W, Wire- wound.	2
		Insulating Oil: Shell Diala-AX High Grade mineral oil	91 Gal. (344.47 Liters)

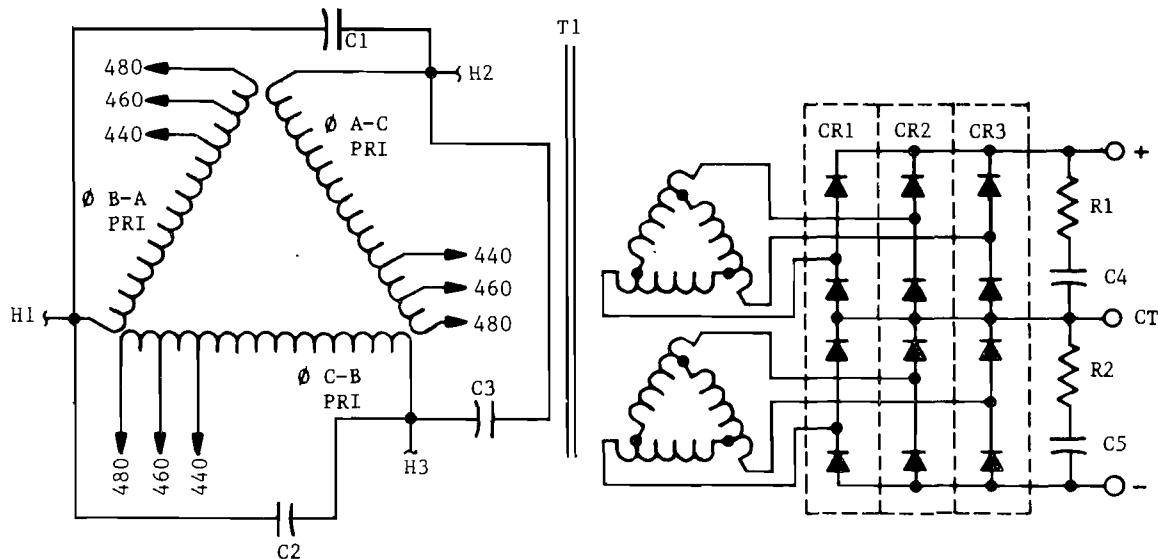

888-2213-001

A3

WARNING: Disconnect primary power prior to servicing.

50 KW SUPPLY

Harris Part No.: 736 0033 000

Harris Specification No.: 815 5032 001

Manufacturer: Aydin Energy Systems, No. 4T43, Dry transformer, dry rectifiers.

Primary: 460 V, $\pm 20V$, 3 \emptyset , 60 Hz, Delta

Maximum Primary Overvoltage: 5%

Secondary: 24.5 kV at 4 Amperes continuous, 12-phase
(98 kW Maximum)

<u>REF. SYMBOL</u>	<u>HARRIS PART NO.</u>	<u>DESCRIPTION</u>	<u>QTY.</u>
CR1 thru CR3	384 0386 000	Rectifier Stack, IR 1HQ10K16A	3
T1		High Voltage Transformer Energy Systems 4B164	1
C1 thru C3	510 0638 000	Power Factor Correction Capacitor, 30 μ F, 500 Vac	3
C4,C5	510 0568 000	Surge Suppression Capacitor, 2 0.02 μ F, $\pm 20\%$, 30 kV	2
R1,R2	542 0354 000	Surge Suppression Resistor, 2 50 ohms, $\pm 5\%$, 225 W, Non- Inductive, Wirewound	2

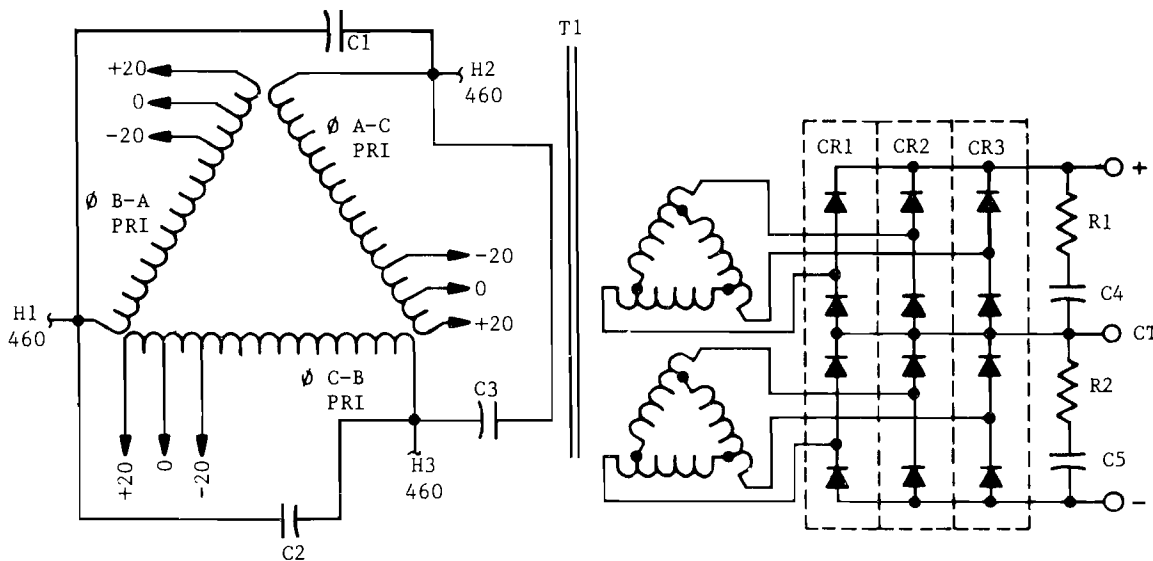

50 KW SUPPLY

Harris Part No.: 736 0084 000

Harris Specification No.: 816 5093 001

Manufacturer: Aydin Energy Systems, No. 2T74, Oil filled transformer, dry rectifiers.

Primary: 365/380/395/410 V, 3 \emptyset , 50/60 Hz, Delta

Maximum Primary Overvoltage: 5%

Secondary: 24.5 kV at 4 Amperes continuous, 12-phase
(98 kW Maximum)

REF. SYMBOL	HARRIS PART NO.	DESCRIPTION	QTY.
CR1 thru CR3	384 0386 000	Rectifier Stack, IR 1HQ10K16A	3
T1		High Voltage Transformer, Energy Systems 1B98	1
C1 thru C3	510 0683 000	Power Factor Correction Capacitor, 30 uF, 500 Vac	3
C4,C5	510 0568 000	Surge Suppression Capaci- tor, 0.02 uF, +20%, 30 kV	2
R1,R2	542 0354 000	Surge Suppression Resis- tor, 50 ohms, +5%, 225 W, Non-Inductive, Wirewound	2
		Insulating Oil: Shell Diala-AX High Grade Mineral Oil	91.7 Gal. (347.12 Liters)

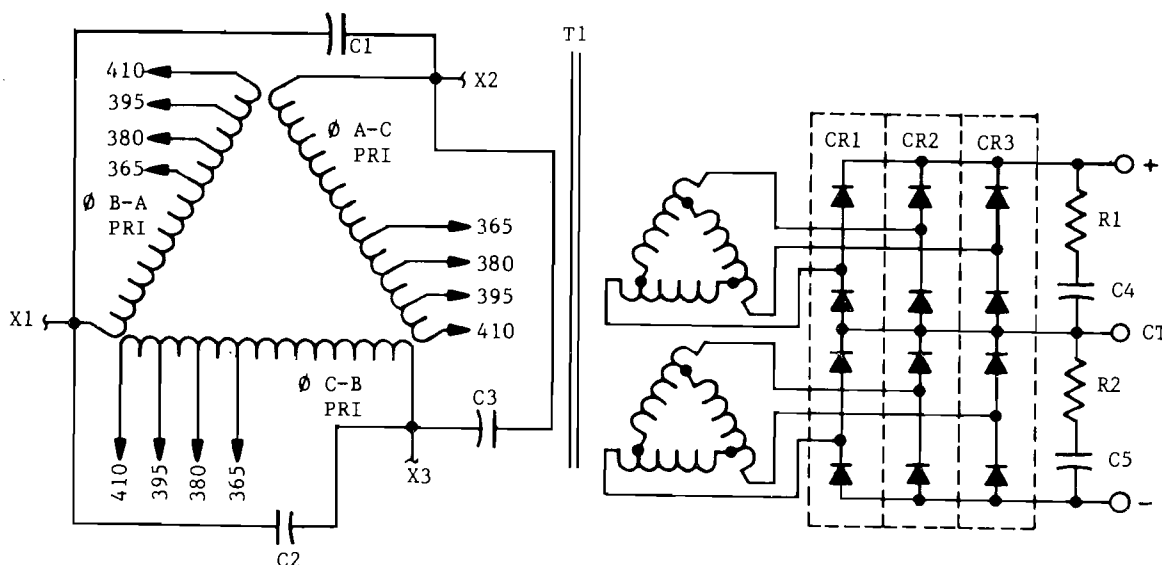

888-2213-001

A5

WARNING: Disconnect primary power prior to servicing.

50 KW SUPPLY

Harris Part No.: 736 0085 000

Harris Specification No.: 816 5094 001

Manufacturer: Aydin Energy Systems, No. 4T50, Dry transformer, dry rectifiers.

Primary: 365/380/395/410 V, 3 \emptyset , 50 Hz, Delta

Maximum Primary Overvoltage: 5%

Secondary: 24.5 kV at 4 Amperes continuous, 12-phase
(98 kW Maximum)

<u>REF. SYMBOL</u>	<u>HARRIS PART NO.</u>	<u>DESCRIPTION</u>	<u>QTY.</u>
CR1 thru CR2	384 0386 000	Rectifier Stack, IR 1HQ10K16A	3
T1		High Voltage Transformer, Energy Systems 4B191	1
C1 thru C3	510 0683 000	Power Factor Correction Capacitor, 30 uF, 500 Vac	3
C4, C5	510 0568 000	Surge Suppression Capacitor, 0.02 uF, +20%, 30 kV	2
R1, R2	542 0354 000	Surge Suppression Resistor, 50 ohms, +5%, 225 W, Non-Inductive, Wirewound	2

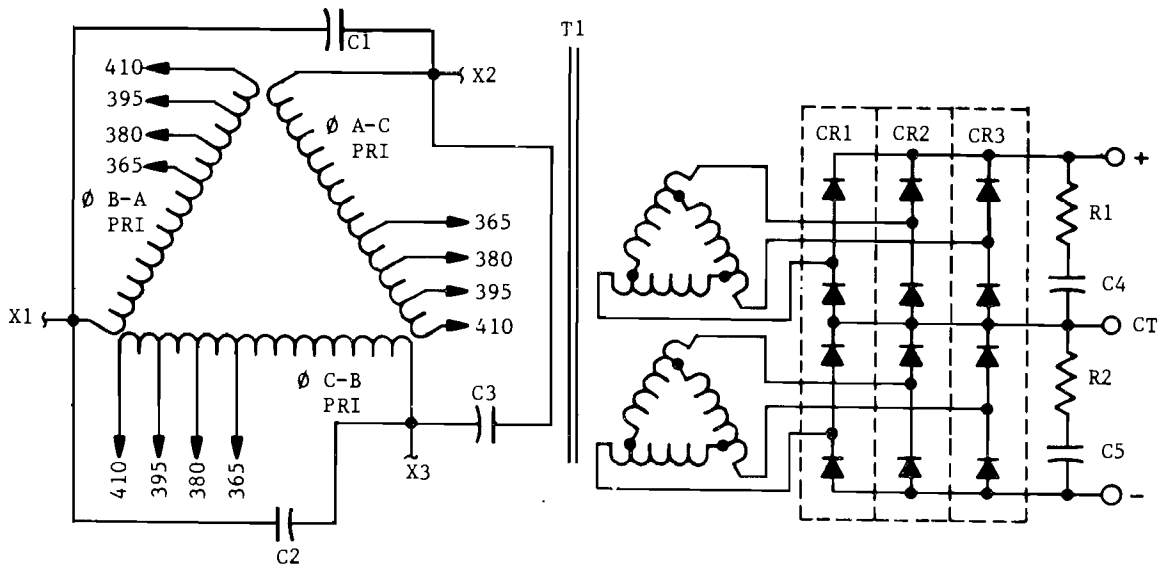

50 KW SUPPLY

Harris Part No.: 736 0119 000

Harris Specification No.: 816 9171 001

Manufacturer: Aydin Energy Systems, No. 2T90, Oil filled transformer, dry rectifiers.

Primary: 380/430/485 V, $\pm 4\%$, 3 \emptyset , 50/60 Hz, Delta

Maximum Primary Overvoltage: 5%

Secondary: 24.5 kV at 4.5 Amperes continuous, 12-phase
(110.25 kW Maximum)

<u>REF. SYMBOL</u>	<u>HARRIS PART NO.</u>	<u>DESCRIPTION</u>	<u>QTY.</u>
CR1 thru CR3	384 0553 000	Rectifier Stack, IR 1HQ10J17A	3
T1		High Voltage Transformer, Aydin Energy Systems 1B136	1
C1,C2	510 0712 000	Surge Suppression Capacitor, 0.03 uF, $\pm 5\%$, 30 kV	2
R1,R2	542 0353 000	Surge Suppression Resistor, 25 ohm, $\pm 5\%$, 200 W, Wire-wound	2
-		Insulating Oil: Shell Diala Diala-AX High Grade Mineral Oil	83 Gal. (314.19 Liters)

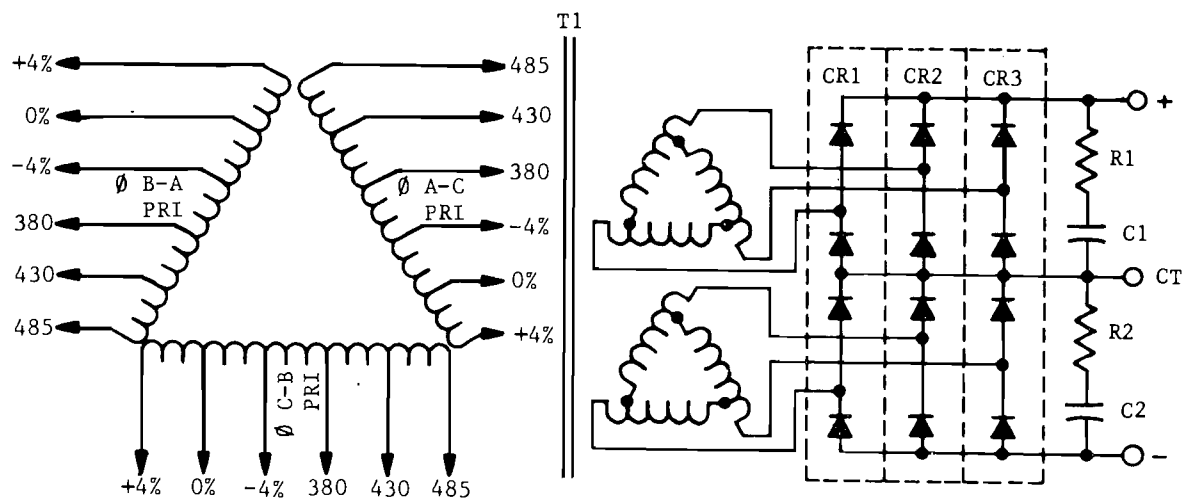

100 KW SUPPLY

Harris Part No.: 736-0038-000

Harris Specification No.: 815-5423-001

Manufacturer: Electro Engineering, No. E17318, Oil filled transformer, dry rectifiers.

Primary: 365/380/395 V, 3Ø, 50/60 Hz, Delta

Maximum Primary Overvoltage: 5%

Secondary: 33/29 KV at 7.6 Amperes continuous, 12-phase
(248 KW Maximum)

<u>REF. SYMBOL</u>	<u>HARRIS PART NO.</u>	<u>DESCRIPTION</u>	<u>QTY.</u>
CR1 thru CR3	384 0627 000	Rectifier Stack, IR 1HQ10J21A	3
C1,C2	510 0693 000	Transient Suppression Capacitor, 0.05 uF, +20%, 25 kV	2
R1,R2	542 0370 000	Transient Suppression Resistor, 15K ohm, +5% 225 W, Wirewound	2
T1		High Voltage Transformer, Electro Engineering E17319	1
-		Insulating Oil: Shell Diala-AX High Grade Mineral Oil	136 Gal. (514.82 Liters)

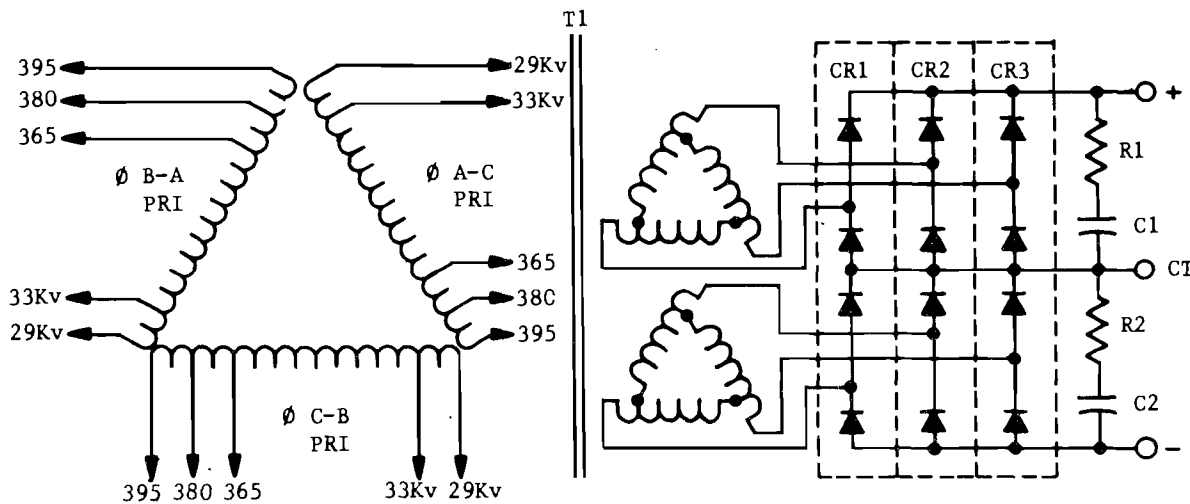

APPENDIX B

MW-50C3 MEDIUM WAVE AM BROADCAST TRANSMITTER

MANUFACTURERS DATA

888-2213-001

B-1

WARNING: Disconnect primary power prior to servicing.

APPENDIX B

MANUFACTURERS DATA

B-1. INTRODUCTION

B-2. This appendix contains technical data sheets which identify operating characteristics and parameters for various replaceable items used in the HARRIS MW-50C3 MEDIUM WAVE AM BROADCAST TRANSMITTER.

B1 - Eimac Engineering Newsletter - WHM65D29 MOD. 9-10-65

B2 - Eimac Technical Data Sheet - 4CX1500A Tetrode

B3 - Eimac Technical Data Sheet - 4CX35000C Tetrode

B4 - HARRIS Engineering Department Power Distribution Recommendation



LIFE VS. FILAMENT VOLTAGE

TUBE TYPES WITH THORIATED-TUNGSTEN FILAMENTS OR CATHODES.

Power tube users and equipment manufacturers are naturally interested in extending the life of these tubes. A very large factor in tube life is the temperature of the thoriated-tungsten cathode.

The equipment manufacturer and the end user of the equipment have more control over tube life through proper adjustment of filament voltage (filament power) than is generally realized. This is true because tube ratings and most equipment designs are conservative in peak cathode emission required of the tube compared with peak cathode emission available at nominal rated filament voltage.

It is good practice to determine in the field for each particular combination of equipment and operating power level, the nominal filament voltage for best life. This is best done in the field by measuring some important parameter of performance such as plate current, power output, or distortion while filament voltage on the power tube is reduced. At some point in filament voltage there will be a noticeable reduction in plate current, or power output, or an increase in distortion. Operation may safely be at a filament voltage slightly higher than that point at which performance appeared to deteriorate. A recheck should be made in 12 to 24 hours to make certain that emission is stable.

The thoriated-tungsten filament or cathode is processed in a hydrocarbon atmosphere to form a deep layer of di-tungsten carbide on the surface. Stable emission is not possible without the carbide. If the carbide layer is too deep the filament becomes too brittle to withstand shipping and handling. The end of useful life for this type of filament occurs when most of the carbon has evaporated or combined with residual gas, depleting the carbide surface layer.

Theoretically it is estimated that a 3% increase in filament voltage will result in a 20°K increase in temperature, a 20% increase in peak emission, and a 50% decrease in life due to carbon loss. This, of course, works the other way, too. For a small decrease in temperature and peak emission, life of the carbide layer and hence tube life can be increased by a substantial percentage. Peak emission as meant here is the emission obtained in the test for emission described in the Test Specification. This is normally many times the peak emission required in communication service.

ENL-12

Continued.....

Obviously, if small percentage variations in filament voltage are to have a large percentage effect on tube life, it is important to be able to measure and adjust filament voltage measured at the tube terminals with accuracy of about 1%.

The common rectifier type of multimeter which is used for almost every measurement in electronic gear, should not be relied on for AC filament voltage measurement. A simple iron-vane AC meter which has recently been checked against a reliable standard is the best inexpensive instrument for this measurement because it responds to the RMS, or heating value, of the voltage wave form.

As a guide for use with most communications, and broadcast equipment, to get the best life service from your EIMAC power tubes, the following table has been prepared. It is not meant to imply that lower filament voltage will not be satisfactory in some instances.

SUGGESTED NOMINAL FILAMENT VOLTAGE

FOR

EXTENDED LIFE IN BROADCAST AND COMMUNICATION SERVICE

<u>TUBE TYPE</u>	
3X2500A3 and F3	7.2 volts
3X3000A1 and A7	7.2
3CX2500A3 and F3	7.2
3CX3000A1 and A7	7.2
3CX10,000A3, A1 and A7	7.2
3CX15,000A3	6.0
6697A	12.3
4-125A	4.8
4-400A	4.8
4-1000A	7.2
4W20,000A	(2300 watts cathode heating power)
4CX3000A	8.6 volts
4CX5000A	7.2
4CX10,000D	7.2
4CX15,000A	6.0
4CX35,000C	9.0
4CV100,000C	9.0
4E27A	4.8
5-500A	9.5
5CX1500A	4.8
5CX3000A	8.6

Credit is due the paper, High Power Transmitting Valves ---, by Walker, Aldous, Roach, Webb and Goodchild, IEE Paper No. 3200E March, 1960, also the paper Life Expectancy Tubes ---, Eitel-McCullough, October 6, 1963, by Paul Williams.



4CX1500A

TECHNICAL DATA

RADIAL BEAM

TETRODE

The EIMAC 4CX1500A is a general purpose tetrode for use up to and through VHF. Insulation is ceramic and the thoriated tungsten filament is a rugged mesh design. The screen terminal is a continuous ring which allows good isolation between the plate circuit and the control grid circuit.

The 4CX1500A is recommended for use as a class C power amplifier, class B, or class AB₁ linear amplifier, as a regulator, and in pulse modulator service.



GENERAL CHARACTERISTICS¹

ELECTRICAL

Filament Voltage	5.0 volts
Filament Current	36.5 amps
Amplification Factor (Grid Screen)	5.5
Transconductance ($I_b = 1$ ampere)	
$E_c = 500$ volts, $E_b = 200$ volts)	26,000 μ mho
Frequency for Maximum Ratings	150 MHz
Direct Interelectrode Capacitances (Grounded Cathode) ²	
C_{in}	78.0 pF
C_{out}	10.5 pF
C_{gp}	0.25 pF

1. Characteristics and operating values are based upon performance tests. These figures may change without notice as the result of additional data or product refinement. EIMAC Division of Varian should be consulted before using this information for final equipment design.
2. Capacitance values are for a cold tube as measured in a special shielded fixture in accordance with Electronic Industries Association Standard RS-191.

MECHANICAL

Base	Special ring and breechblock terminal surfaces
Recommended Socket	EIMAC SK-831
Recommended Air Chimney	EIMAC SK-806
Operating Position	Axis Vertical
Maximum Anode Core Temperature	250°C
Maximum Seal Temperature	250°C
Cooling	Forced Air

WARNING: Disconnect primary power prior to servicing.

4CX1500A

Maximum Dimensions

Height	4.90 in; 124.5 mm
Diameter.....	3.37 in; 85.6 mm
Net Weight	30 oz; 850 gm
Shipping Weight (Approximately)	3 lb; 1.21 kg

RANGE VALUES FOR EQUIPMENT DESIGN

	<u>Min.</u>	<u>Max.</u>
Filament Current, $E_f = 5.0$ V	36.5	40.5 A
Interelectrode Capacitance (grounded cathode circuit) ¹		
C _{in}	73.0	83.0 pF
C _{out}	8.5	12.5 pF
C _{gp}	---	0.4 pF

1. Capacitance values are for a cold tube as measured in a special shielded fixture in accordance with Electronic Industries Association Standard RS-191.

RADIO-FREQUENCY LINEAR AMPLIFIER

Class AB

TYPICAL OPERATION Class AB₁

MAXIMUM RATINGS:

DC PLATE VOLTAGE	4000 VOLTS
DC SCREEN VOLTAGE	750 VOLTS
DC PLATE CURRENT	1.0 AMPERE
PLATE DISSIPATION	1500 WATTS
SCREEN DISSIPATION	75 WATTS
CONTROL GRID DISSIPATION	25 WATTS

DC Plate Voltage	2500	3900 V
DC Screen Voltage	600	600 V
DC Grid Voltage ¹	-105	-110 V
Zero-Signal Plate Current	250	200 mA
Max-Signal Plate Current	765	750 mA
Max-Signal Screen Current ²	46	40 mA
Peak RF Driving Voltage	95	100 v
Resonant Plate Load Resistance ...	1670	2900 Ω
Max-Signal Plate Power Out	1080	1850 W

1. Adjust to specified zero-signal dc plate current.
2. Approximate values.

RADIO-FREQUENCY POWER AMPLIFIER OR OSCILLATOR

Class C Telegraphy or FM

(Continuous Operating Conditions)

TYPICAL OPERATION

MAXIMUM RATINGS:

DC PLATE VOLTAGE	5000 VOLTS
DC SCREEN VOLTAGE	750 VOLTS
DC PLATE CURRENT	1.0 AMPERE
PLATE DISSIPATION	1500 WATTS
SCREEN DISSIPATION	75 WATTS
CONTROL GRID DISSIPATION	25 WATTS

	<u>Low Freq. Calculated</u>		<u>220 MHz Measured</u>
DC Plate Voltage	3000	4000	3000 V
DC Screen Voltage	500	500	500 V
DC Grid Voltage	-200	-200	-116 V
DC Plate Current	800	800	1000 mA
DC Screen Current ²	36	37	35 mA
DC Grid Current ²	17	15	0 mA
Peak RF Grid Voltage	240	240	--- v
Driving Power	4.1	3.6	31.5 W
Resonant Load Resistance	1720	2570	--- Ω
Plate Dissipation	600	700	--- W
Power Output	1800	2500	1500 W ¹

1. Useful Power Output
2. Approximate values.

PLATE-MODULATED RADIO-FREQUENCY POWER AMPLIFIER

Class C Telephony
(Carrier Conditions unless noted)

MAXIMUM RATINGS:

DC PLATE VOLTAGE	3500 VOLTS
DC SCREEN VOLTAGE	550 VOLTS
DC PLATE CURRENT8 AMPERE
PLATE DISSIPATION ¹	1000 WATTS
SCREEN DISSIPATION	75 WATTS
CONTROL GRID DISSIPATION	25 WATTS

1. Corresponds to 1500 watts at 100% sine-wave modulation.

TYPICAL OPERATION

	Low Frequency Calculated	
DC Plate Voltage	2500	3400 V
DC Screen Voltage	500	500 V
DC Grid Voltage	-300	-300 V
Peak Audio Screen Voltage (For 100% mod. approx.)	500	500 v
DC Plate Current	800	900 mA
DC Screen Current ²	46	28 mA
DC Grid Current ²	27	28 mA
Peak RF Grid Voltage	365	365 v
Grid Driving Power	10	10 W
Resonant Load Resonant	3200	1940 Ω
Plate Dissipation	620	780 W
Plate Power Out	1600	2320 W

2. Approximate value.

AUDIO-FREQUENCY AMPLIFIER OR MODULATOR

Class AB

MAXIMUM RATINGS:

DC PLATE VOLTAGE	4000 VOLTS
DC SCREEN VOLTAGE	750 VOLTS
DC PLATE CURRENT	1.0 AMPERE
PLATE DISSIPATION	1500 WATTS
SCREEN DISSIPATION	75 WATTS
CONTROL GRID DISSIPATION	25 WATTS

TYPICAL OPERATION (Two Tubes) Class AB₁

DC Plate Voltage	2500	3900 V
DC Screen Voltage	600	600 V
DC Grid Voltage	-105	-110 V
Zero-Signal Plate Current	500	400 mA
Max-Signal Plate Current	1.530	1.500 A
Max-Signal Screen Current ²	90	80 mA
Peak AF Driving Voltage	95	100 v
Load Resistance Plate to Plate	3340	5800 Ω
Max-Signal Plate Dissipation ¹	820	1070 W
Max-Signal Plate Power Out	2160	3700 W

1. Per Tube
2. Approximate value.

NOTE: TYPICAL OPERATION data is obtained by direct measurement or by calculation from published characteristic curves. Adjustment of the rf grid voltage to obtain the specified plate current at the specified bias screen and plate voltage is assumed. If this procedure is followed, there will be little variation in output power when the tube is changed, even though there may be some variation in grid and screen current. The grid and screen currents which result when the desired plate current is obtained are incidental and vary from tube to tube. These current variations cause no difficulty so long as the circuit maintains the correct voltage in the presence of the variations in current. In Class C service, if grid bias is obtained principally by means of a grid resistor, the resistor must be adjustable to obtain the required bias voltage when the correct rf grid voltage is applied.

APPLICATION

MECHANICAL

MOUNTING - The 4CX1500A must be operated with its axis vertical. The base of the tube may be down or up at the convenience of the circuit designer.

SOCKET - The EIMAC SK-831 socket and SK-806 chimney have been designed especially for the 4CX1500A. The use of recommended air-flow rates through these sockets provides effective forced-air cooling of the tube. Air forced into the bottom of the socket passes over the

tube terminals through the Air Chimney, and through the anode cooling fins.

COOLING - The maximum temperature rating for the anode core of the 4CX1500A is 250°C. Sufficient forced-air circulation must be provided to keep the temperature of the anode at the base of the cooling fins and the temperature of the ceramic/metal seals below 250°C. Air-flow requirements to maintain seal temperature at 225°C in 50°C ambient air are tabulated on page 4 (for operation below 30 MHz).

4CX1500A

Plate Dissipation (Watts)	SEA LEVEL		6000 FEET	
	Air Flow (CFM)	Pressure Drop (Inches of Water)	Air Flow (CFM)	Pressure Drop (Inches of Water)
1000	27	0.33	33	0.40
1500	47	0.76	58	0.95

*Since the power dissipated by the filament represents about 200 watts and since grid-plus-screen dissipation can, under some conditions, represent another 100 watts, allowance has been made in preparing this tabulation for an additional 300 watts dissipation.

The blower selected in a given application must be capable of supplying the desired air flow at a back pressure equal to the pressure drop shown above plus any drop encountered in ducts and filters.

At other altitudes and ambient temperatures the flow rate must be modified to obtain equivalent cooling. The flow rate and corresponding pressure differential must be determined individually in such cases, using rated maximum temperatures as the criteria for satisfactory cooling.

ELECTRICAL

FILAMENT OPERATION - The rated filament voltage for the 4CX1500A is 5.0 volts. Filament voltage, as measured at the socket, should be maintained at this value or below to obtain maximum tube life.

CONTROL GRID OPERATION - The rated dissipation of the grid is 25 watts. This is approximately the product of dc grid current and peak positive grid voltage. Operation at bias and drive levels near those listed will insure safe operation.

SCREEN GRID OPERATION - The power dissipated by the screen of the 4CX1500A must not exceed 75 watts.

Screen dissipation, in cases where there is no ac applied to the screen, is the simple product of the screen voltage and the screen current. If the screen voltage is modulated, the screen dissipation will depend upon RMS screen current and voltage.

Screen dissipation is likely to rise to excessive values when the plate voltage, bias voltage, or plate load are removed with filament and screen voltages applied. Suitable protective means must be provided to limit the screen dissipation to 75 watts in the event of circuit failure.

HIGH VOLTAGE - Normal operating voltages used with the 4CX1500A are deadly, and the equipment must be designed properly and operating precautions must be followed. Design all equipment so that no one can come in contact with high voltages. All equipment must include safety enclosures for high-voltage circuits and terminals, with interlock switches to open primary circuits of the power supply and to discharge high-voltage condensers whenever access doors are opened. Interlock switches must not be bypassed or "cheated" to allow operation with access doors open. Always remember that HIGH VOLTAGE CAN KILL.

RADIO FREQUENCY RADIATION - Avoid exposure to strong rf fields even at relatively low frequency. Absorption of rf energy by human tissue is dependent on frequency. Under 30 MHz, most of the energy will pass completely through the human body with little attenuation or heating effect. Public health agencies are concerned with the hazard, however, even at these frequencies, and it is worth noting that some commercial dielectric heating units actually operate at frequencies as low as the 13 and 27 MHz bands.

INTERELECTRODE CAPACITANCE - The actual internal interelectrode capacitance of a tube is influenced by many variables in most applications, such as stray capacitance to the chassis, capacitance added by the socket used, stray capacitance between tube terminals, and wiring effects. To control the actual capacitance values within the tube, as the key component involved, the industry and the Military Services use a standard test procedure as described in Electronic Industries Association Standard RS-191. This requires the use of specially constructed test fixtures which effectively shield all external tube leads from each other and eliminates any capacitance reading to "ground".

The test is performed on a cold tube. Other factors being equal, controlling internal tube capacitance in this way normally assures good interchangeability of tubes over a period of time, even when the tube may be made by different manufacturers. The capacitance values shown in the manufacturer's technical data, or test specifications, normally are taken in accordance with Standard RS-191.

The equipment designer is therefore cautioned to make allowance for the actual capacitance values which will exist in any normal application. Measurements should be taken with the socket and mounting which represent approximate final layout if capacitance values are highly significant in the design.

MULTIPLE OPERATION - To obtain maximum power output with minimum distortion from tubes operated in multiple, it is desirable to adjust individual screen or grid bias voltages so that the peak plate current for each tube is equal at the crest of the exciting voltage. Under these conditions, individual dc plate currents will be approximately equal for full input signal.

SPECIAL APPLICATION - If it is desired to operate this tube under conditions widely different from those listed here, write to Power Grid Tube Division, EIMAC Division of Varian, 301 Industrial Way, San Carlos, California 94070, for information and recommendations.

TYPICAL CONSTANT CURRENT CHARACTERISTICS
GROUNDED CATHODE SCREEN VOLTAGE = 500V
— PLATE CURRENT - AMPERES - - - SCREEN CURRENT - AMPERES - - - GRID CURRENT - AMPERES

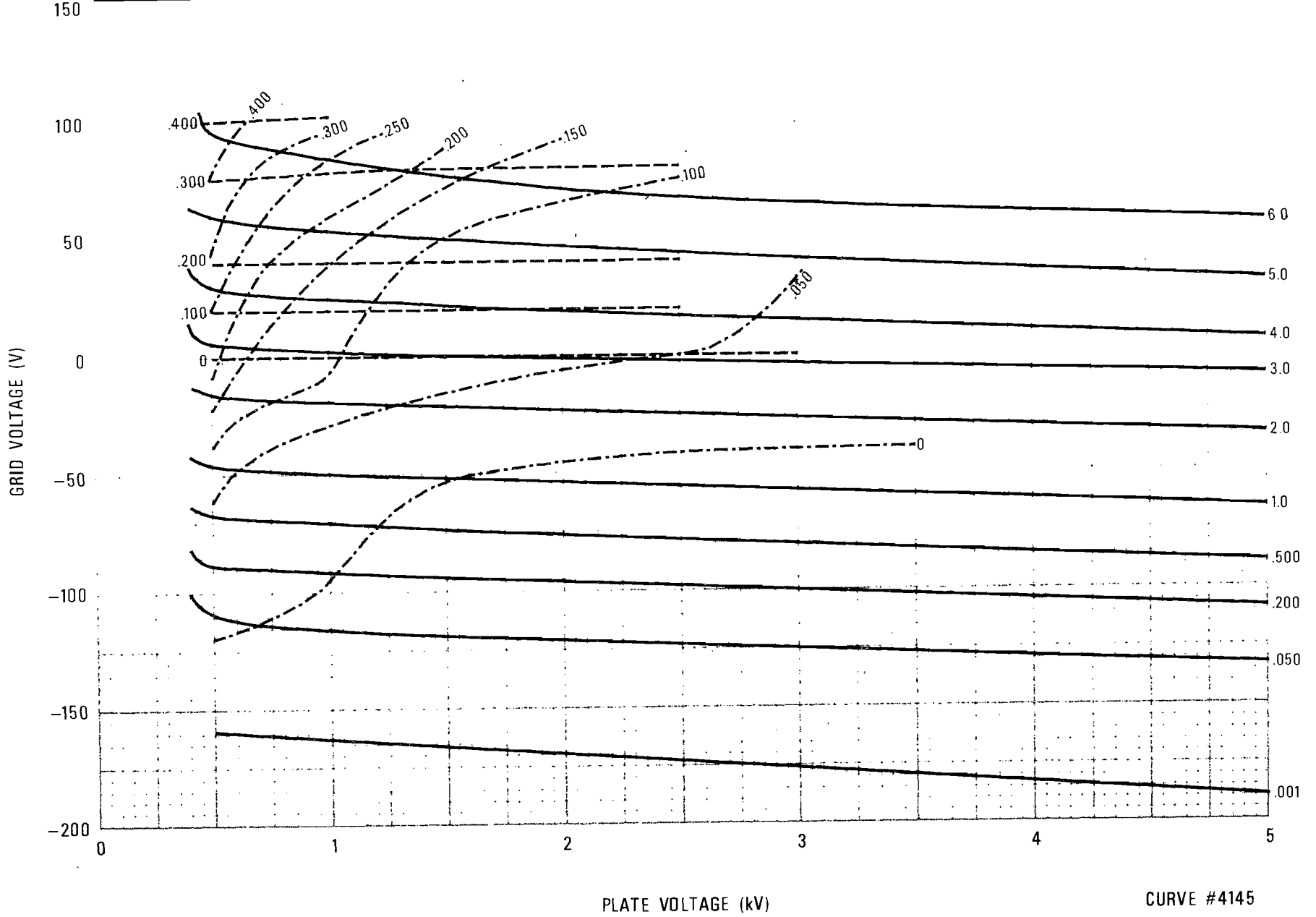

B-10

WARNING: Disconnect primary power prior to servicing.

888-2213-001

PLATE VOLTAGE (kV)

CURVE #4145

TYPICAL CONSTANT CURRENT CHARACTERISTICS

GROUNDED CATHODE SCREEN VOLTAGE = 750V

— PLATE CURRENT — AMPERES - - - - SCREEN CURRENT — AMPERES - - - - GRID CURRENT — AMPERES

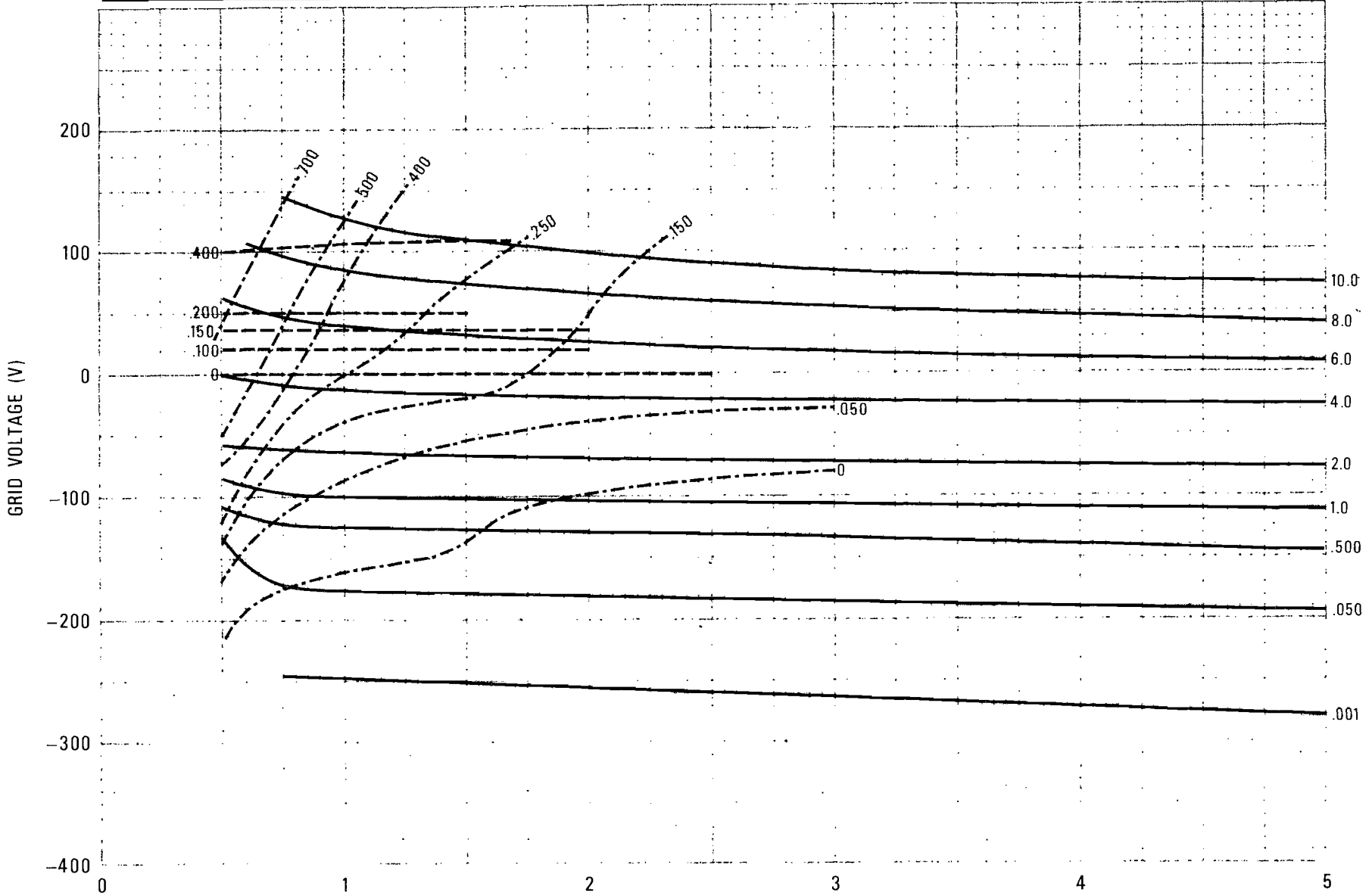

WARNING: Disconnect primary power prior to servicing.

888-2213-001

B-11

PLATE VOLTAGE (kV)

CURVE #4146



TECHNICAL DATA

8349
4CX35,000C

RADIAL-BEAM
POWER TETRODE

The EIMAC 8349/4CX35,000C is a ceramic/metal, forced-air cooled power tetrode intended for use at the 50 to 150 kilowatt output power level. It is recommended for use as a Class-C rf amplifier or oscillator, a Class-AB rf linear amplifier, or a Class-AB push-pull af amplifier or modulator. The 8349/4CX35,000C is also useful as a plate and screen modulated Class-C rf amplifier.

The forced-air cooled anode is rated at 35 kilowatts maximum dissipation.

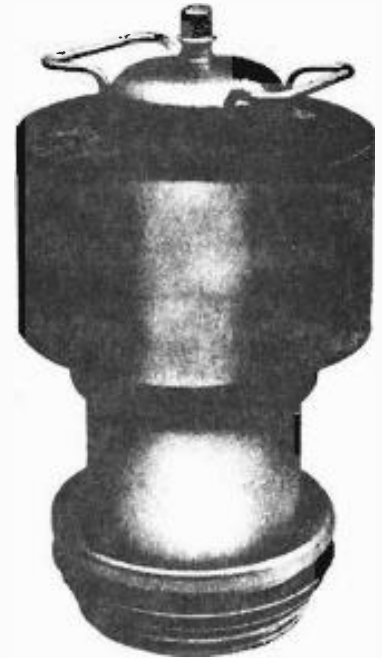

GENERAL CHARACTERISTICS ¹

ELECTRICAL

Filament: Thoriated Tungsten

Voltage 10.0 V

Current, at 10.0 volts 295 A

Amplification Factor (Average):

Grid to Screen 4.5

Direct Interelectrode Capacitances (grounded cathode)²

C_{in} 440 pF

C_{out} 55 pF

C_{gp} 2.3 pF

Frequency of Maximum Rating:

CW 30 MHz

1. Characteristics and operating values are based upon performance tests. These figures may change without notice as the result of additional data or product refinement. EIMAC Division of Varian should be consulted before using this information for final equipment design.

2. Capacitance values are for a cold tube as measured in a special shielded fixture in accordance with Electronic Industries Association Standard RS-191.

MECHANICAL

Maximum Overall Dimensions:

Length 17.34 in; 440.4 mm

Diameter 9.75 in; 247.7 mm

Net Weight 50 lb; 22.7 kg

Operating Position Vertical, base up or down

Maximum Operating Temperature:

Ceramic/Metal Seals 250°C

Anode Core 250°C

Cooling Forced Air

Base Special, graduated rings

Recommended Socket EIMAC SK-1500 Series

B-13

888-2213-001

WARNING: Disconnect primary power prior to servicing.

4CX35,000C

RADIO FREQUENCY LINEAR AMPLIFIER GRID DRIVEN

Class AB

MAXIMUM RATINGS:

DC PLATE VOLTAGE	20,000	VOLTS
DC SCREEN VOLTAGE	2500	VOLTS
DC PLATE CURRENT	15.0	AMPERES
PLATE DISSIPATION	35,000	WATTS
SCREEN DISSIPATION	1750	WATTS
GRID DISSIPATION	500	WATTS

1. Adjust to specified zero-signal dc plate current.
2. Approximate value.

TYPICAL OPERATION (Frequencies to 30 MHz)
Class AB₁, Grid Driven, Peak Envelope or Modulation
Crest Conditions

Plate Voltage	15.0	kVdc
Screen Voltage	1.5	kVdc
Grid Voltage ¹	-400	Vdc
Zero-Signal Plate Current	1.0	Adc
Single Tone Plate Current	5.7	Adc
Single-Tone Screen Current ²	0.9	Adc
Peak rf Grid Voltage ²	250	v
Peak Driving Power ²	0	w
Plate Dissipation	30	kW
Plate Output Power	55	kW
Resonant Load Impedance	1280	Ω

RADIO FREQUENCY POWER AMPLIFIER OR OSCILLATOR

Class C Telephony or FM
(Key-Down Conditions)

MAXIMUM RATINGS:

DC PLATE VOLTAGE	20,000	VOLTS
DC SCREEN VOLTAGE	2500	VOLTS
DC PLATE CURRENT	15.0	AMPERES
PLATE DISSIPATION	35,000	WATTS
SCREEN DISSIPATION	1750	WATTS
GRID DISSIPATION	500	WATTS

TYPICAL OPERATION (Frequencies to 30 MHz)

Plate Voltage	10.0	15.0	19.0	kVdc
Screen Voltage	750	750	750	Vdc
Grid Voltage	-425	-480	-550	Vdc
Plate Current	7.5	6.8	6.96	Adc
Screen Current ¹	0.84	0.51	0.80	Adc
Grid Current ¹	0.29	0.23	0.35	Adc
Peak rf Grid Voltage ¹	600	660	730	v
Calculated Driving Power ¹	180	150	258	W
Plate Dissipation	19.3	19.0	21.0	kW
Plate Output Power	55.5	82.5	110	kW

1. Approximate value.

PLATE MODULATED RADIO FREQUENCY POWER AMPLIFIER-GRID DRIVEN

Class C Telephony (Carrier Conditions)

MAXIMUM RATINGS:

DC PLATE VOLTAGE	14,000	VOLTS
DC SCREEN VOLTAGE	2000	VOLTS
DC PLATE CURRENT	15.0	AMPERES
PLATE DISSIPATION ¹	23,000	WATTS
SCREEN DISSIPATION ²	1750	WATTS
GRID DISSIPATION ²	500	WATTS

1. Corresponds to 35,000 watts at 100% sine-wave modulation.
2. Average, with or without modulation.

TYPICAL OPERATION (Frequencies to 30 MHz)

Plate Voltage	12.0	kVdc
Screen Voltage	750	Vdc
Grid Voltage	-600	Vdc
Plate Current	5.4	Adc
Screen Current ¹	0.52	Adc
Grid Current ¹	0.16	Adc
Peak rf Screen Voltage ² (100% modulation)	500	v
Peak rf Grid Voltage ¹	740	v
Calculated Driving Power	125	W
Plate Dissipation	13.2	kW
Plate Output Power	55.0	kW
Resonant Load Impedance	1120	Ω

1. Approximate value.
2. Approximate value, depending upon degree of driver modulation.

4CX35,000C

AUDIO FREQUENCY POWER AMPLIFIER OR MODULATOR

Class AB, Grid Driven (Sinusoidal Wave)

MAXIMUM RATINGS (Per Tube):

DC PLATE VOLTAGE	20,000	VOLTS
DC SCREEN VOLTAGE	2,500	VOLTS
DC PLATE CURRENT	15.0	AMPERES
PLATE DISSIPATION	35,000	WATTS
SCREEN DISSIPATION	1750	WATTS
GRID DISSIPATION	500	WATTS

1. Approximate value.

TYPICAL OPERATION (Two Tubes)

Plate Voltage	12.0	kVdc
Screen Voltage	1.5	kVdc
Grid Voltage ^{1/3}	-400	Vdc
Zero-Signal Plate Current	3.0	Adc
Max Signal Plate Current	9.2	Adc
Max Signal Screen Current ¹	1.8	Adc
Peak af Grid Voltage ²	280	v
Max Signal Plate Dissipation ²	20	kW
Plate Output Power	70	kW
Load Resistance (plate to plate)	2860	Ω

2. Per Tube

3. Adjust to give stated zero-signal plate current.

NOTE: TYPICAL OPERATION data are obtained from direct measurement or by calculation from published characteristic curves. Adjustment of the rf grid voltage to obtain the specified plate current at the specified bias, screen and plate voltages is assumed. If this procedure is followed, there will be little variation in output power when the tube is changed, even though there may be some variation in grid and screen current. The grid and screen currents which result when the desired plate current is obtained are incidental and vary from tube to tube. These current variations cause no difficulty so long as the circuit maintains the correct voltage in the presence of the variations in current. In the case of Class C Service, if grid bias is obtained principally by means of a grid resistor, the resistor must be adjustable to obtain the required bias voltage when the correct rf grid voltage is applied.

RANGE VALUES FOR EQUIPMENT DESIGN

	<u>Min.</u>	<u>Max.</u>
Heater: Current at 10.0 volts	280	310 A
Interelectrode Capacitances (grounded cathode connection) ²		
C _{in}	410	470 pF
C _{out}	50	60 pF
C _{gp}	1.5	3.2 pF

2. Capacitance values are for a cold tube as measured in a special shielded fixture in accordance with Electronic Industries Association Standard RS-191.

APPLICATION

MECHANICAL

MOUNTING - The 4CX35,000C must be operated with its axis vertical. The base of the tube may be down or up at the convenience of the circuit designer.

SOCKET - The EIMAC sockets, type SK-1500, and SK-1510 have been designed especially for the concentric base terminals of the 4CX35,000C.

COOLING - The maximum temperature rating for the external surfaces of the 4CX35,000C is 250°C. Sufficient forced-air circulation must be provided to keep the temperature of the anode at the base of the cooling fins and the temperature of the ceramic/metal seals below 250°C.

Air-flow requirements to maintain core temperature at 225°C in 40° ambient air are tabulated below (for operation below 30 megahertz.) These data are for air flowing in the base-to-anode direction.

Plate Dissipation (Watts)	Base-to-Anode Air Flow			
	Sea Level		10,000 Feet	
	Air Flow (CFM)	Pressure Drop(Inches of Water)	Air Flow (CFM)	Pressure Drop(Inches of Water)
15,000	440	1.0	635	1.44
20,000	650	2.0	935	2.9
25,000	975	3.8	1400	5.5
30,000	1300	6.0	1870	8.6
35,000	1760	9.6	2535	13.8

* Since the power dissipated by the filament represents about 3000 watts and since grid-plus-screen dissipation can, under some conditions, represent another 2250 watts, allowance has been made in preparing this tabulation for an additional 5250 watts dissipation.

4CX35,000C

The blower selected in a given application must be capable of supplying the desired air flow at a back pressure equal to the pressure drop shown above plus any drop encountered in ducts and filters.

Separate cooling of the tube base is required and is accomplished by directing approximately 120 cfm of air horizontally through the socket from the side. It is preferable to direct this air through three equally spaced ducts.

The well in the center of the baseplate of the tube is a critical area which requires cooling to maintain envelope temperatures less than 250°C. For most applications, 1 to 2 CFM of air directed through the center of the socket is sufficient for this purpose.

At other altitudes and ambient temperatures the flow rate must be modified to obtain equivalent cooling. The flow rate and corresponding pressure differential must be determined individually in such cases, using rated maximum temperatures as the criteria for satisfactory cooling.

ELECTRICAL

FILAMENT OPERATION - The peak emission at rated filament voltage of the EIMAC 4CX35,000C is normally many times the peak emission required for communication service. A small decrease in filament temperature due to reduction of filament voltage can increase the life of the 4CX35,000C by a substantial percentage. It is good practice to determine the nominal filament voltage for a particular application that will not affect the operation of the equipment. This is done by measuring some important parameter of performance such as plate current, power output, or distortion while filament voltage is reduced on the 4CX35,000C. At some point in filament voltage there will be a noticeable reduction in plate current, or power output, or an increase in distortion. Operation may be at a filament voltage slightly higher than that point at which performance appears to deteriorate. This voltage should be measured at the socket with a 1% meter and periodically checked to maintain proper operation.

Filament starting current must be limited to a maximum of 900 amperes.

Voltage between filament and the base plates of tube and SK-1500 socket, must not exceed 100 volts.

GRID OPERATION - The 4CX35,000C grid has a maximum dissipation rating of 500 watts. Precautions should be observed to avoid exceeding this rating. The grid bias and driving power

should be kept near the values shown in the "Typical Operation" sections of the data sheet whenever possible. The maximum grid circuit resistance should not exceed 100,000 ohms per tube.

SCREEN OPERATION - The power dissipated by the screen of the 4CX35,000C must not exceed 1750 watts.

Screen dissipation, in cases where there is no ac applied to the screen, is the simple product of the screen voltage and the screen current. If the screen voltage is modulated, the screen dissipation will depend upon loading, driving power, and carrier screen voltage.

Screen dissipation is likely to rise to excessive values when the plate voltage, bias voltage, or plate load are removed with filament and screen voltages applied. Suitable protective means must be provided to limit the screen dissipation to 1750 watts in the event of circuit failure.

PLATE DISSIPATION - The plate-dissipation rating for the 4CX35,000C is 35,000 watts. When the 4CX35,000C is operated as a plate-modulated rf amplifier, under carrier conditions, the maximum plate dissipation is 23,000 watts.

INTERELECTRODE CAPACITANCE - The actual internal interelectrode capacitance of a tube is influenced by many variables in most applications, such as stray capacitance to the chassis, capacitance added by the socket used, stray capacitance between tube terminals, and wiring effects. To control the actual capacitance values within the tube, as the key component involved, the industry and the Military Services use a standard test procedure as described in Electronic Industries Association Standard RS-191. This requires the use of specially constructed test fixtures which effectively shield all external tube leads from each other and eliminates any capacitance reading to "ground". The test is performed on a cold tube. Other factors being equal, controlling internal tube capacitance in this way normally assures good interchangeability of tubes over a period of time, even when the tube may be made by different manufacturers. The capacitance values shown in the manufacturer's technical data, or test specifications, normally are taken in accordance with Standard RS-191.

The equipment designer is therefore cautioned to make allowance for the actual capaci-

tance values which will exist in any normal application. Measurements should be taken with the socket and mounting which represent approximate final layout if capacitance values are highly significant in the design.

HIGH VOLTAGE - Normal operating voltages used with the 4CX35,000C are deadly, and the equipment must be designed properly and operating precautions must be followed. Design all equipment so that no one can come in contact with high voltages. All equipment must include safety enclosures for high-voltage circuits and terminals, with interlock switches to open primary circuits of the power supply and to discharge high-voltage condensers whenever access doors are opened. Interlock switches must not be bypassed or "cheated" to allow operation with access doors open. Always remember that **HIGH VOLTAGE CAN KILL**.

FAULT PROTECTION - In addition to normal cooling airflow interlock and plate and screen over-current interlocks, it is good practice to protect the tube from internal damage which could result from occasional plate arcing at high plate voltage.

In all cases some protective resistance, at least one or two ohms, should be used in series with the tube anode to absorb power supply stored energy in case a plate arc should occur. Where stored energy is high, it is recommended that some form of electronic crowbar be used which will discharge power supply capacitors in as short a time as possible following indication of start of a plate arc.

X-RADIATION - High-vacuum tubes operating at voltages higher than 10 kilovolts produce progressively more dangerous X-ray radiation as the voltage is increased. The 4CX35,000C, operating at its rated voltages and currents, is a potential X-ray hazard. Only limited shielding is afforded by the tube envelope. Moreover, the X-ray radiation level can increase significantly with aging and gradual deterioration, due to leakage paths or emission characteristics as they are affected by the high voltage. X-ray shielding must be provided on all sides of tubes operating at these voltages to provide adequate protection throughout the tube's life. Periodic checks on the X-ray level should be made, and the tube should never be operated without adequate shielding in place when voltages above 10 kilovolts are in use. Lead glass, which attenuates X-rays, is available for viewing windows. If there is any doubt as to the requirement for or the adequacy of shielding, an expert in this field should be contacted to perform an X-ray survey of the equipment.

Operation of high-voltage equipment with interlock switches "cheated" and cabinet doors open in order to be better able to locate an equipment malfunction can result in serious X-ray exposure.

SPECIAL APPLICATIONS - If it is desired to operate this tube under conditions widely different from those given here, write to Power Grid Tube Product Manager, EIMAC Division of Varian, 301 Industrial Way, San Carlos, California 94070 for information and recommendations.

4CX35,000C

EIMAC 4CX 35,000C
TYPICAL
CONSTANT CURRENT
CHARACTERISTICS
 SCREEN VOLTAGE = 1500 VOLTS
 — PLATE CURRENT — AMPERES
 - - - SCREEN CURRENT — AMPERES
 - - - - GRID CURRENT — AMPERES

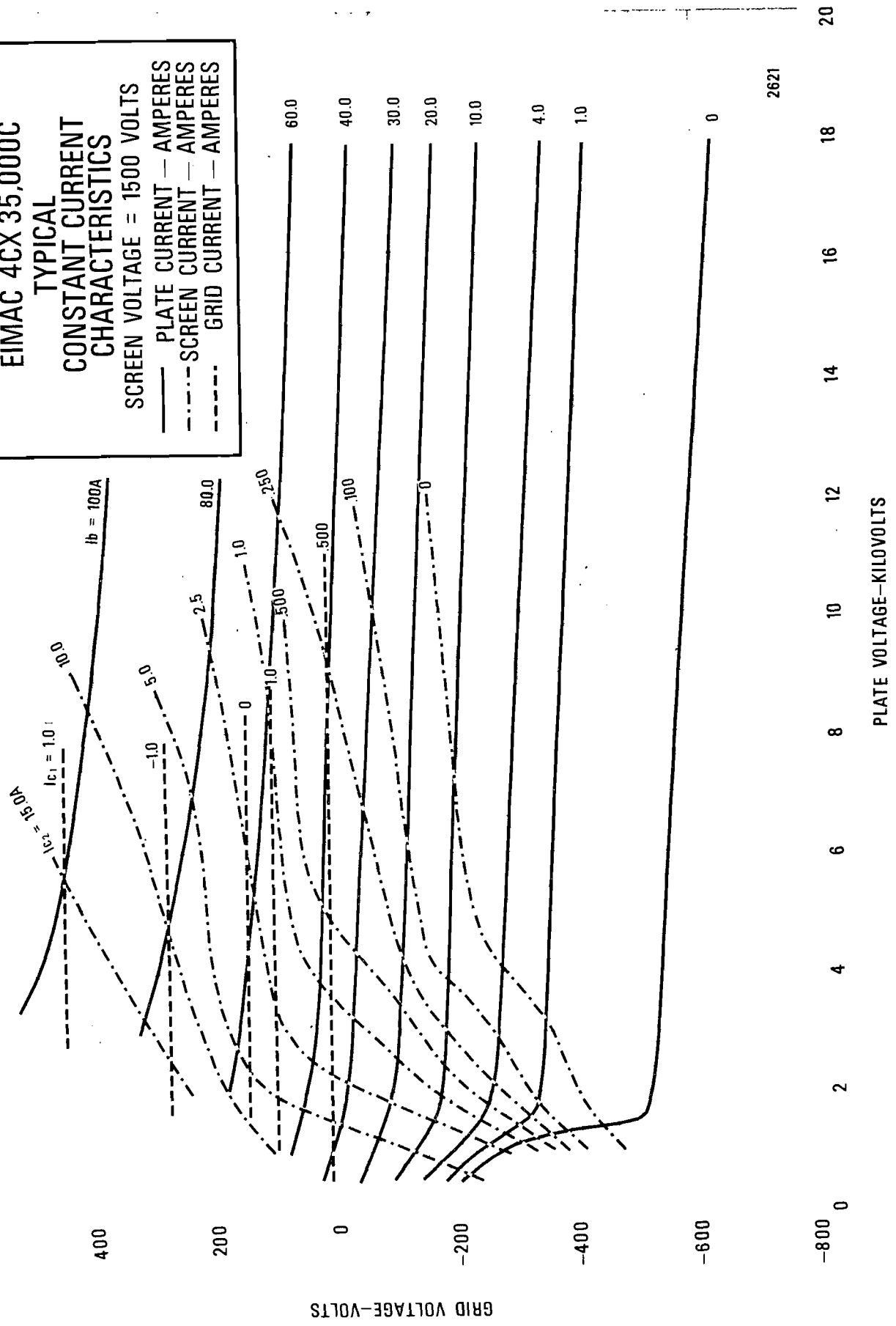

2621

WARNING: Disconnect primary power prior to servicing.

WARNING: Disconnect primary power prior to servicing.

888-2213-001

B-19

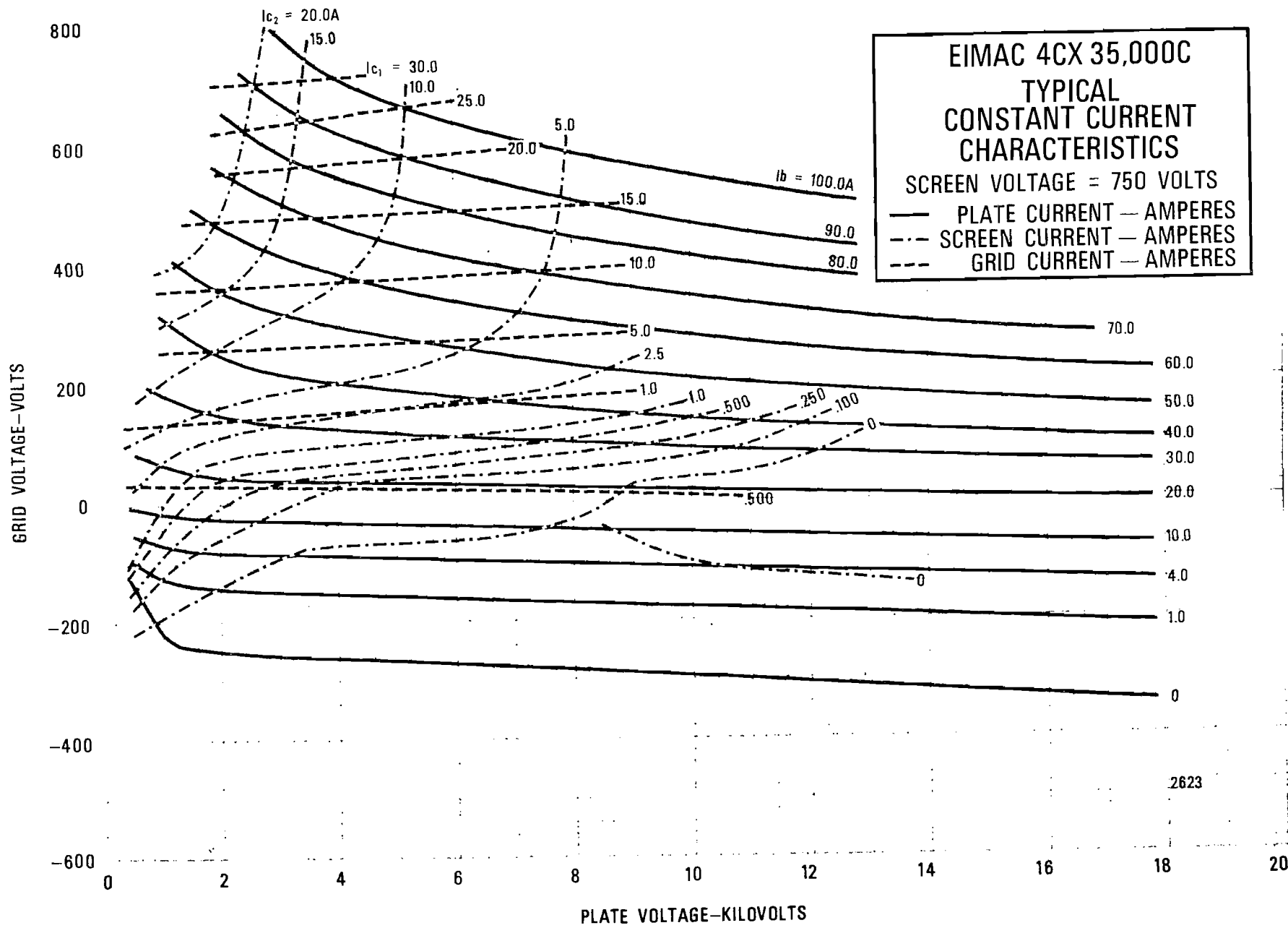

4CX35,000C

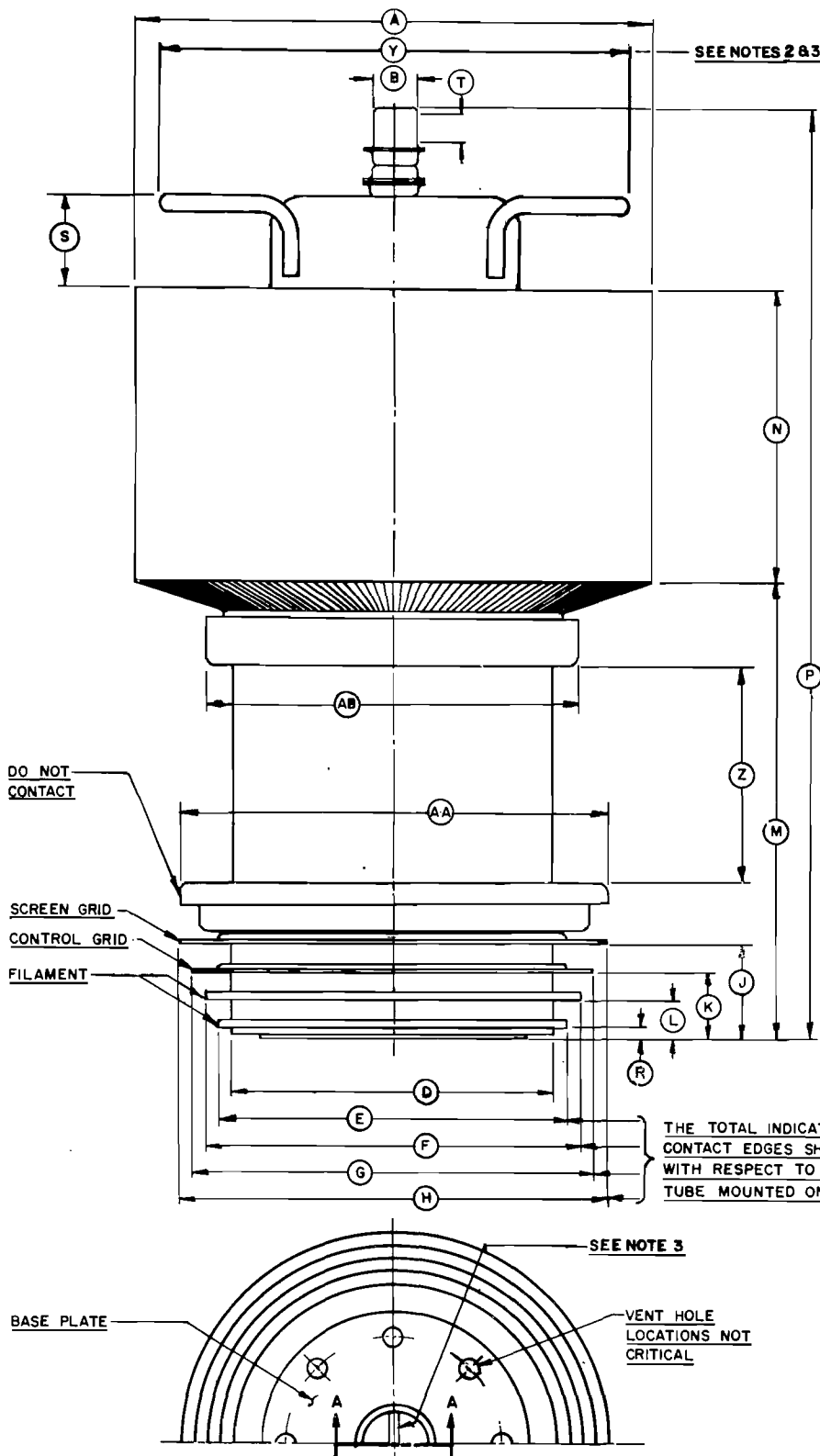

DIMENSIONAL DATA				
DIM.	INCHES		MILLIMETERS	
	MIN.	MAX.	MIN.	MAX.
A	9.500	9.750	241.30	247.65
B	0.860	0.890	21.84	22.60
D	5.980	6.020	151.89	152.91
E	6.510	6.560	165.35	166.62
F	6.980	7.020	177.29	178.31
G	7.480	7.520	189.99	191.01
H	7.975	8.015	202.57	203.58
J	1.750	1.800	44.45	45.72
K	1.220	1.270	30.99	32.26
L	0.690	0.740	17.53	18.80
M	8.442	8.692	214.43	220.78
N	5.375	5.625	136.52	142.88
P	17.070	17.340	433.58	440.44
R	0.173	0.213	4.40	5.41
S	1.750		44.45	
T	0.485	0.515	12.32	13.08
V	--	0.135	--	3.43
W	1.250	1.270	31.75	32.26
X	0.490	0.530	12.45	13.46
Y	--	8.750	--	222.25
Z	3.750		95.25	
AA	8.000		203.20	
AB	6.875		174.63	

- NOTES:**
1. REFERENCE DIMENSIONS ARE FOR INFORMATION ONLY AND ARE NOT REQUIRED FOR INSPECTION PURPOSES.
 2. DIM. Y IS MAXIMUM DIA. ACROSS CORNERS
 3. HANDLE LATERAL AXIS ORIENTATION WITH BASE LOCK PIN IS AS SHOWN.

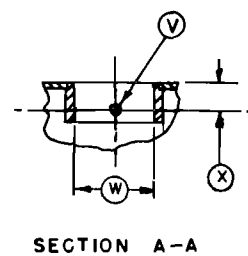

WARNING: Disconnect primary power prior to servicing.

HARRIS ENGINEERING DEPARTMENT
POWER DISTRIBUTION RECOMMENDATION

Radio and Television transmitters using three-phase power must operate with the line-to-line voltages well balanced. Operation with the incoming line-to-line voltages substantially unbalanced will increase the ripple from the three-phase power supplies, primarily at twice the power line frequency, and thus increase the hum of the transmitter. Unbalanced line voltages result in unbalanced currents in the windings of the three-phase transformers, and in unbalanced currents in the windings of three-phase motors.

Three-phase motors should be run with line voltage balance within 1%; a 3-1/2 percent line voltage unbalanced will produce a temperature rise approximately 25% above normal in the winding carrying the greater of the unbalanced currents, while a 5% unbalance will produce a temperature rise approximately 50% greater than normal.

The regulation of a three-phase open delta transformer bank is much poorer than that of a closed delta bank.⁽¹⁾ The closed delta bank is symmetrical; the open delta is not; so the regulation in each of the three phases differs widely, and the effect of this may be an appreciable line voltage unbalance. The regulation of a closed delta is symmetrical on each phase.

Depending upon the impedances of the two transformers making up the open delta this appreciable line voltage unbalance may be great enough to impair satisfactory operation of the transmitter. HARRIS customers have experienced this with open delta distribution, and when the third transformer was added for closed delta service, the problem disappeared.

Transient overvoltages with open delta distribution can cause transmitter damage, particularly to the silicon rectifiers used in the main HV power supply. This is sometimes troublesome when the open delta transformers are at the end of a long overhead open wire distribution system. Several HARRIS

1. "Transformer Engineering" - Blume, Boyajian, Camilli, Lennox, Minneci, & Montsinger (John Wiley & Sons). 2nd 1967.

customers, upon following the HARRIS recommendation and adding the third transformer, have found the difficulty gone.

Although the above argument specifically calls out Closed Delta distribution, a WYE distribution also uses three transformers, and is symmetric, avoiding the difficulties arising from the non-symmetrical configuration of the Open Delta distribution.

WYE TYPE POWER DISTRIBUTION

In large segments of the world the power distribution is four-wire WYE. Single phase service is derived between the neutral of the WYE distribution and any one of the three other wires.

Three-phase main power supply transformers for small transmitters - 10 kilowatts or less - in the United States are generally operated from three-phase lines in the 210 to 250 volt range, line to line. HARRIS has adopted the practice of specifying three-phase transformers for transmitters of this class with three separate primaries, each having appropriate taps to accommodate the several nominal voltages in this range. For service in the United States these primaries are connected in Delta.

For service in those parts of the world in which the power distribution is four-wire WYE in the 360 to 415-volt range these three primaries are connected in WYE, with each primary tapped for the line to neutral voltage. The neutral point of the three primaries of the transformer within the transmitter is solidly connected to the power distribution system neutral, to provide a path for zero sequence currents, as well as any harmonic currents which might flow due to the rectification of the secondary voltages.

The line-to-line voltage is equal to the line to neutral voltage multiplied by the square root of three (1.732 approximately), nominally.

Typical system voltages: (Nominal)

LINE TO NEUTRAL (single phase)

LINE TO LINE (three phase)

210 volts

364 volts

220 volts

380 volts

230 volts

400 volts

240 volts

415 volts

250 volts

433 volts

In summary, either a closed delta or WYE distribution system is satisfactory for HARRIS transmitter.