

Western Electric
8-B Speech Input Equipment
Instructions For Use

No. 8-B
SPEECH INPUT EQUIPMENT

The equipment described in this Bulletin
was designed and developed for the
Western Electric Company
by
BELL TELEPHONE LABORATORIES

No. 8-B

SPEECH INPUT EQUIPMENT

INSTRUCTIONS
FOR USE



Western Electric Company

Instruction Bulletin No. 366

Copyright 1931
WESTERN ELECTRIC COMPANY, Inc.

Printed in U. S. A.

CONTENTS

INTRODUCTION AND GENERAL DESCRIPTION	1
Panel Assemblies	2
General	2
No. D-87908 Amplifier Panel	2
No. D-87990 Miscellaneous Equipment Panel	3
No. D-88823 Power Panel	15
Filament Power Supply	19
Batteries	19
Charging Equipment	20
Condenser Transmitters and Associated Equipment	20
Apparatus on Panel Assemblies	27
No. 8-C Amplifier	27
No. 18-B Amplifier	31
No. 203-B Panel	33
No. 514-A Panel	35
No. 1-B Rectifier	36
No. D-86852 Control Cabinet	41
ADJUSTMENT	45
Starting	45
Power	45
Condenser Transmitters and Associated Equipment	46
Controls	47
Meter Indications	47
Stopping	48
OPERATION	49
Condenser Transmitters	49
Studio Control System	49
Outside Line Circuits	50
Volume Indicator	51
Monitoring	52
Battery Charging	53
MAINTENANCE	55
General	55
Vacuum Tubes	55
Batteries	55
Storage Batteries	55
Dry Batteries	56
Relays	56
Jacks, Keys and Lamps	58
Cords and Plugs	58

Potentiometers and Rheostats	59
Maintenance Equipment	59
LOCATION OF TROUBLES	61
General	61
Battery Supply	61
Plate Supply	62
Amplifiers	62
Signal Circuits	64
Condenser Transmitter Circuits	64
APPARATUS INFORMATION	65
Fuses	65
Vacuum Tubes	65
Lamps	65
Cords	65
Spare Parts	65
Information for Ordering Replacements	65
TELEPHONE SERVICE	66
ENGINEERING SERVICE	66
SCHEMATIC AND WIRING DIAGRAMS	67
INDEX	89

ILLUSTRATIONS

Three Panel Assembly of No. 8-B Speech Input Equipment.....	Frontispiece
Key to Schematic Diagrams	2, 68
Wiring Diagram of No. D-87908 Amplifier Panel.....	69
No. D-87990 Miscellaneous Equipment Panel	
Front View	4
Rear View	5
Wiring Diagram	71
Schematic of Typical Studio Control System.....	6, 70
Schematic of Outside Line Control Circuits.....	10, 73
Schematic of Amplification and Gain Control Circuits.....	12, 74
Jack Strip Designations	14
No. D-88823 Power Panel	
Front View	16
Rear View	17
Schematic of Power Supply Circuits.....	18, 75
Typical Storage Battery Installation	19
Battery Charge and Discharge Cycles.....	19
No. 394 Transmitter With Shipping Box.....	20
No. 47-B Condenser Transmitter Amplifier	21
Schematic of No. 394 Transmitter and Associated Amplifier and Dia- gram of External Connections	22, 76
No. 48-A Condenser Transmitter Amplifier	23
No. 7-A Transmitter Mounting	23
No. 8-A Transmitter Mounting	24
Schematic of Condenser Transmitter Amplifier Control Circuits.....	25, 77
No. 8-C Amplifier	
Front View	28
Rear View	29
Schematic Diagram	26, 78
Wiring Diagram	79
No. 18-B Amplifier	
Front View	30
Rear View	30
Schematic Diagram	31, 80
Wiring Diagram	81
No. 203-B Panel	
Front View	32
Rear View	32
Schematic Diagram	34, 82
Wiring Diagram	83
No. 514-A Panel	
Front View	36
Wiring Diagram	37, 84

No. 1-B Rectifier	
Front View	38
Rear View	39
Schematic Diagram	40, 86
Wiring Diagram	87
No. D-86852 Control Equipment	
Front View	41
Rear View	42
Wiring Diagram	85
Interphone Telephone Set	43

SCHEMATIC AND WIRING DIAGRAMS

Key to Schematic Diagrams	68
Wiring Diagram of No. D-87908 Amplifier Panel.....	69
Schematic of Typical Studio Control System.....	70
Wiring Diagram of No. D-87990 Miscellaneous Equipment Panel.....	71
Schematic of Outside Line Control Circuits	73
Schematic of Amplification and Gain Control Circuits.....	74
Schematic of Power Supply Circuits	75
Schematic of No. 394 Transmitter and Associated Amplifier and Diagram of External Connections	76
Schematic of Condenser Transmitter Amplifier Control Circuits.....	77
Schematic of No. 8-C Amplifier	78
Wiring Diagram of No. 8-C Amplifier	79
Schematic of No. 18-B Amplifier	80
Wiring Diagram of No. 18-B Amplifier	81
Schematic of No. 203-B Panel	82
Wiring Diagram of No. 203-B Panel	83
Wiring Diagram of No. 514-A Panel	84
Wiring Diagram of No. D-86852 Control Cabinet.....	85
Schematic of No. 1-B Rectifier	86
Wiring Diagram of No. 1-B Rectifier	87

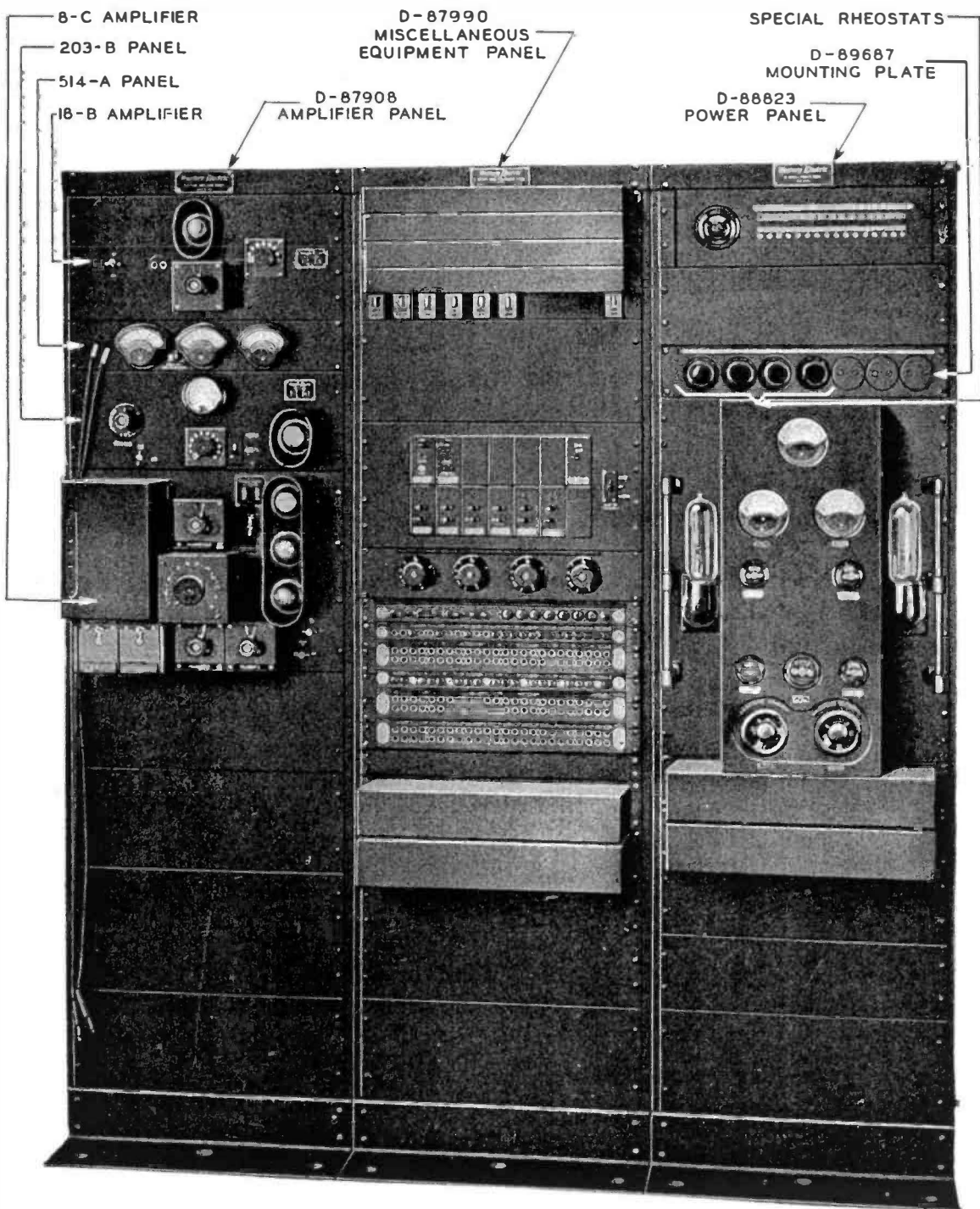

Three Panel Assembly of No. 8-B Speech Input Equipment

No. 8-B SPEECH INPUT EQUIPMENT

Instructions for Use

INTRODUCTION AND GENERAL DESCRIPTION

The No. 8-B Speech Input Equipment affords modern facilities for improved broadcasting quality for medium power radio transmitting stations. The equipment is used at the studio location, either when the studio and the radio transmitter are at the same location or when they are at points widely separated. The apparatus, designed for Western Electric Company, is the result of research and development carried on by Bell Telephone Laboratories.

Condenser transmitters are provided for converting into electrical energy the sounds to be broadcast, and apparatus is also provided for amplifying the energy thus obtained to a suitable level before it is sent to the radio transmitter. A monitoring system is provided to enable the operator to control the amplifying apparatus intelligently. A studio control system is incorporated to facilitate switching of program circuits, together with an interphone system for communication between the control room and the studio. In addition there is included adequate power supply for the apparatus.

The No. 8-B Speech Input Equipment consists of an assembly of apparatus on three panels to be located in the control room. In addition there are the condenser transmitters and studio control cabinet to be located in the studio, and the storage batteries with associated charging equipment. The panels mount the necessary amplifiers; the volume indicator used for visual monitoring; the meter panel for testing and adjusting the equipment; the condenser transmitter control and mixing circuits; the relays for switching and outside line signalling; the control panel for the studio control system; the jacks for switching and testing the equipment; the fuse panels for the battery circuits; and the high voltage rectifier with its associated resistances for supplying direct current to the plate circuits of the vacuum tubes of the amplifiers and of the volume indicator and for maintaining the necessary difference of potential between the plates of the condenser transmitters. The individual panels of this assembly and the units mounted on them are described in detail in subsequent sections. A front view of the three panel assembly is shown on the opposite page.

The apparatus regularly furnished as part of the No. 8-B Speech Input Equipment provides for one studio only. The descriptive matter and the schematics contained in these instructions are presented on the assumed basis that three of the condenser transmitters will be installed in the studio and the fourth in the control room. For installations differing from the assumed standard, the schematics will be similar in general layout but will vary in detail according

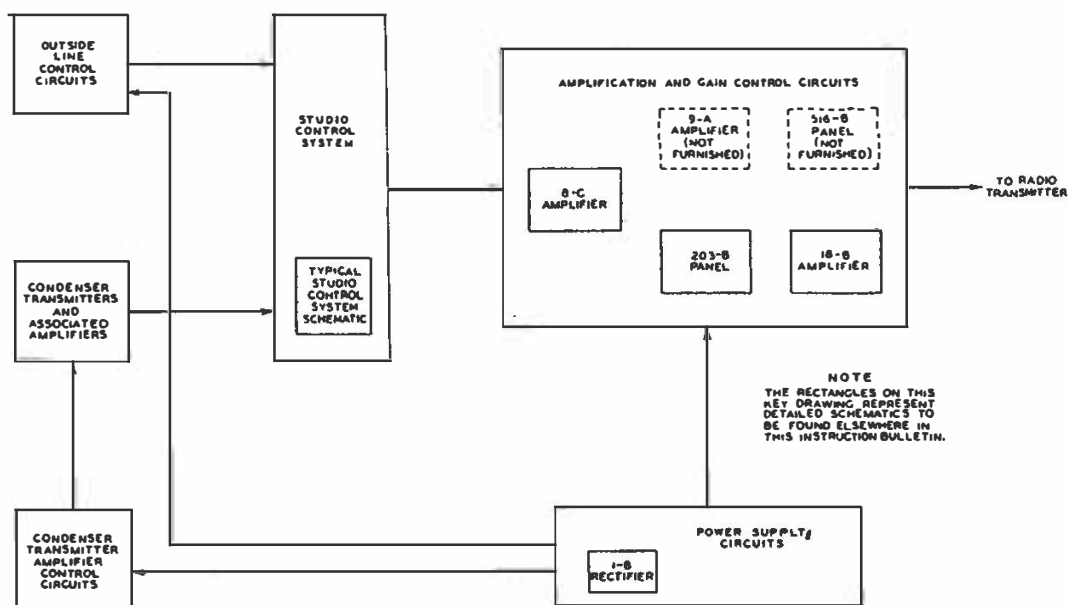

Key to Schematic Drawings

to the individual case. For instance, in the case of an installation having more than one studio, or in which the location of the condenser transmitters differs from the assumed arrangement, the circuit arrangements shown on the schematic of amplification and gain control circuits and the studio control system schematic can be considered as typical only.

PANEL ASSEMBLIES

General

In the descriptive matter which follows reference is made to position numbers. The system of designating mounting positions is as follows. The mounting positions are first numbered from left to right, looking at the front of the apparatus. If the mounting has more than one horizontal row of mounting positions, those in the top row are numbered first as just described and the subsequent rows are numbered consecutively in the same way. If apparatus can be mounted on the rear of the mounting plate the system of numbering is the same except that the positions are numbered from left to right looking at the rear of the apparatus. If both sides of the mounting are used, the mounting positions on the front are numbered first, and then the numbering is continued as described on the rear.

No. D-87908 Amplifier Panel

This panel consists of a framework on which are mounted the line amplifier (No. 8-C Amplifier), the monitoring amplifier (No. 18-B Amplifier), the volume indicator (No. 203-B Panel*) and the meter panel (No. 514-A Panel).

* Later No. D-87908 Amplifier Panels use the No. 203-C Panel. This panel is identical with the No. 203-B Panel, insofar as its use in this equipment is concerned.

This panel is assembled as a unit and the input and output terminals of the apparatus are wired at the factory to a terminal strip on the rear of the panel to facilitate installation. Although not regularly furnished as part of this equipment, a power amplifier (No. 9-A Amplifier) and a volume control panel (No. 516-B Panel) for operating several loud speaking telephones in studios or reception rooms may be mounted on this assembly, and wiring is provided to care for the possible subsequent addition of these units. The input and output terminals of the amplifiers and the input terminals of the volume indicator are connected, when the equipment is installed, to jacks on the miscellaneous equipment panel described below, to facilitate testing and to provide flexibility of the equipment as a whole. A No. D-92296 Output Transformer*, mounted on the No. D-87339 Mounting Plate at the rear of the No. D-87908 Amplifier Panel, is used to balance the output circuit of the No. 18-B Amplifier. The No. D-87908 Amplifier Panel is illustrated opposite page 1, and its wiring diagram is shown on page 69. The apparatus mounted on the amplifier panel is described in the section entitled "Apparatus on Panel Assemblies."

No. D-87990 Miscellaneous Equipment Panel

The No. D-87990 Miscellaneous Equipment Panel, like the Amplifier Panel, is assembled and wired at the factory. This is shown on pages 4 and 5 and its wiring diagram on page 71.

At the top of the miscellaneous equipment panel are the mounting plates which mount the relays of the studio control system. Beginning at the top, the first No. D-86778 Mounting Plate mounts six No. R-1770 Relays in positions 1 to 4 and 7 and 8. The relays in the first four positions are associated with the four condenser transmitter amplifier circuits, while the other two are used with the outside program line circuits. They are operated by non-locking push buttons designated "ON," which are contained in the No. D-85644 Apparatus Units, on the No. D-85650 Panel and in the No. D-86852 Control Cabinet. Each No. R-1770 Relay, when operated, connects the associated condenser transmitter amplifier circuit or outside program line to the input of the No. 8-C Amplifier. In the unoperated position the relay disconnects the associated condenser transmitter amplifier circuit or outside program line from the input of the main speech input amplifier and connects in its place a resistance mounted on the No. D-86775 Mounting Plate, so as to keep the impedance of the circuit approximately constant regardless of the number of condenser transmitter amplifiers or outside line circuits connected.

The second No. D-86778 Mounting Plate mounts six No. R-1086 Relays in positions 1 to 4, and 7 and 8. These relays, as mentioned in the preceding paragraph, are associated respectively with the four condenser transmitter amplifier circuits and two outside program line circuits. They are operated by non-locking push buttons designated "OFF" which are contained in the No. D-85644 Apparatus Units on the No. D-85650 Panel and in the No. D-86852 Control

* The No. D-92296 Output Transformer was not included in earlier No. D-87908 Amplifier Panels.

Cabinet. Each No. R-1086 Relay, when operated, breaks the locking circuit of the associated No. D-86880 (or No. D-87170) and No. R-1770 Relays, disconnecting the associated condenser transmitter amplifier circuit or outside program line as the case may be.

The third No. D-86778 Mounting Plate mounts four No. D-86880 Relays in positions 1 to 4, two No. D-87170 Relays in positions 7 and 8, and one No. E-241 Relay in position 10. The No. D-86880 Relays are associated with the four

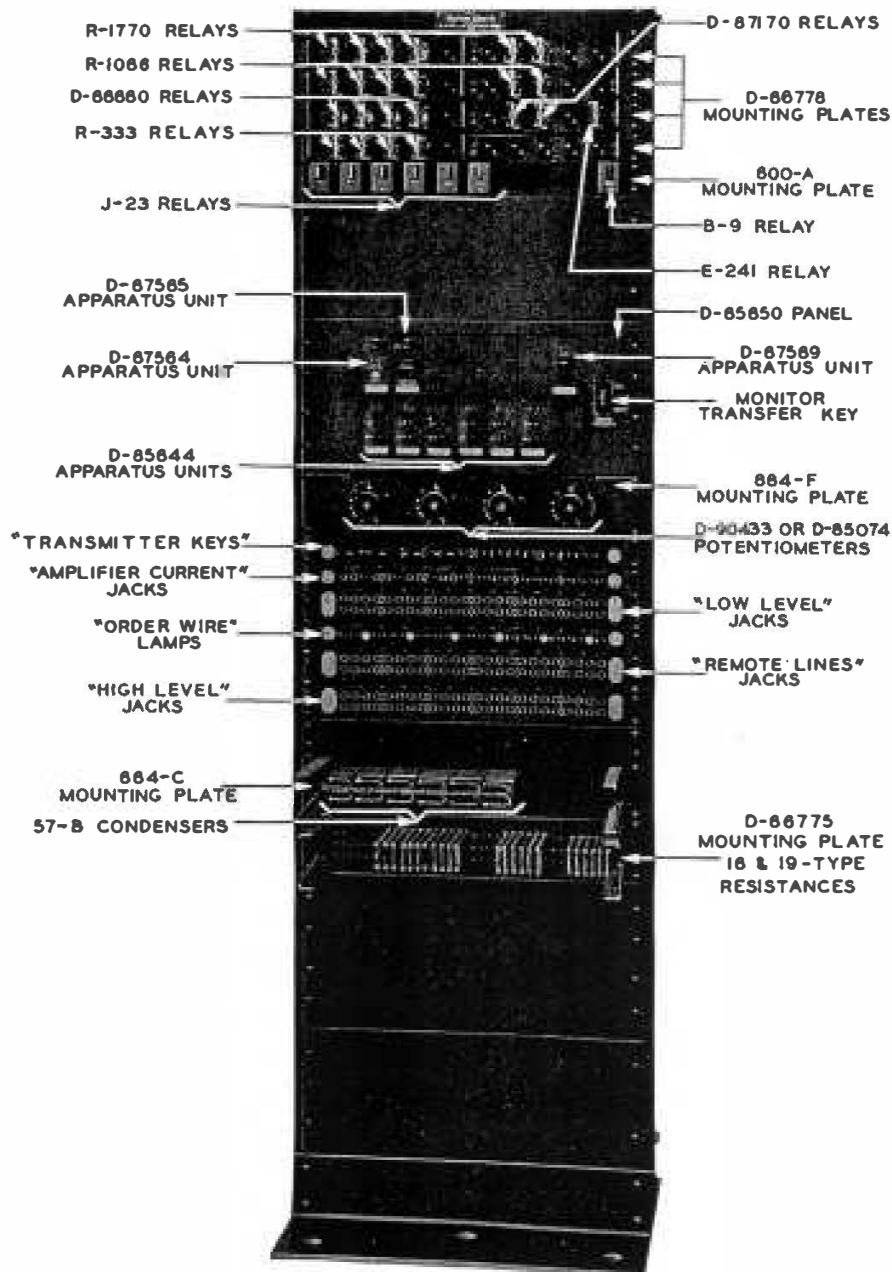

No. D-87990 Miscellaneous Equipment Panel—Front View

condenser transmitter amplifier circuits, while the No. D-87170 Relays are associated with the outside program line circuits. Both the No. D-86880 and the No. D-87170 Relays are provided with two windings, one for operating and one for locking. They are operated through their operating windings by non-locking push buttons marked "ON" contained in the No. D-85644 Apparatus Unit on the No. D-85650 Panel. Once operated, they are locked through their locking windings and auxiliary contacts until their locking circuits are broken by the operation of the associated No. R-1086 Relays, controlled by the "OFF"

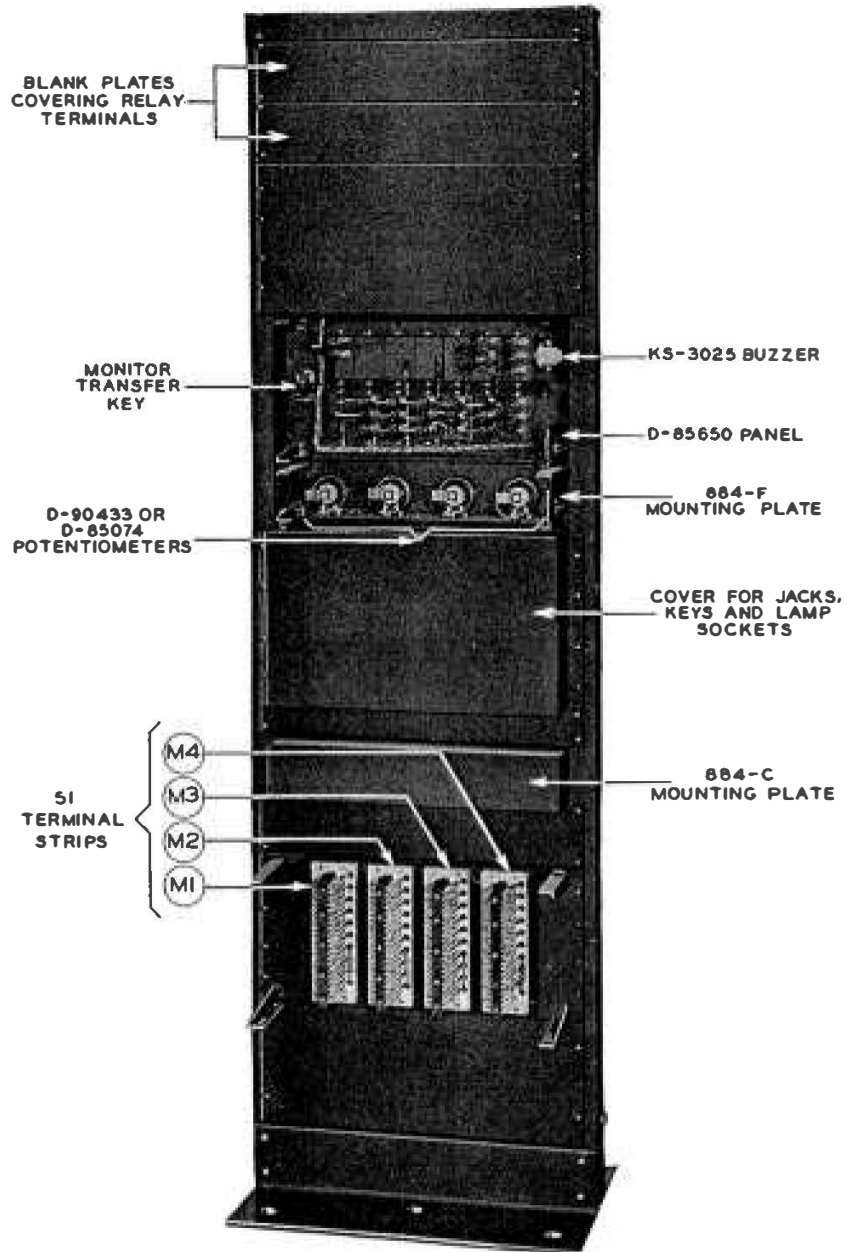

No. D-87990 Miscellaneous Equipment Panel—Rear View

buttons of the No. D-85644 Apparatus Units. The No. D-86880 Relays may also be controlled from the No. D-85644 Apparatus Units of the No. D-86852 Control Cabinet in the studio. The No. D-87170 Relays can be controlled only from the No. D-85650 Panel in the control room, unless additional No. D-85644 Apparatus Units are provided in the No. D-86852 Control Cabinet. The reason for this arrangement is given in the section entitled "Operation." A typical schematic of the studio control system of the No. 8-B Speech Input Equipment is shown on pages 6 and 70, and may be referred to in conjunction with this description of the switching relay circuits.

When operated, each No. D-86880 or No. D-87170 Relay closes the operating circuit to the associated No. R-1770 relay, which when operated connects the desired condenser transmitter amplifier circuit or outside program line to the input of the No. 8-C Amplifier. Each No. D-86880 Relay, associated with a condenser transmitter amplifier circuit, when operated not only closes its own locking circuit and the operating circuit of the associated No. R-1770 Relay but, in addition, opens the circuit of the interphone signalling buzzer at the point where the associated condenser transmitter is located, disconnects the loud speaking telephone at that point, lights a signal lamp on the No. D-85650 Panel and in the No. D-86852 Control Cabinet to indicate that the relay is operated and operates a supplementary relay to control the intensity of illumination in the studio if such relay is used. The circuit of the signalling buzzer is opened to avoid the possibility of broadcasting the sound produced when this buzzer is operated. The loud speaking telephone is disconnected when a condenser transmitter in the same room is connected, to avoid acoustic singing through the loud speaking telephone, condenser transmitter and amplifiers. A flood-light control relay, when used, changes the illumination in the studio whenever a condenser transmitter in that studio is connected to the input of the No. 8-C Amplifier, as a warning that any sounds that are made in the studio will be amplified and broadcast.

On each No. D-87170 Relay is an extra pair of contacts which may be used, if desired, to close the operating circuit to a signal at the remote pick-up point, as an indication that the associated switching relays are operated.

The No. E-241 Relay is operated whenever the speech input equipment is in operation until the "READY" key of the No. D-87569 Apparatus Unit on the No. D-85650 Panel is operated, at which time it releases. In the operated position this relay disconnects the output of the speech input equipment from the line to the radio transmitter so that no sounds can be broadcast from the studio location. When the No. E-241 Relay is released by the operation of the "READY" key mentioned above, the output of the speech input equipment is connected to the input of the radio transmitter, and the green-capped "READY" lights on the No. D-87569 Apparatus Unit of the No. D-85650 Panel and on the No. D-87567 Apparatus Unit of the No. D-86852 Control Cabinet, are lighted to indicate that the station is ready for broadcasting. By releasing the "READY" key, or by pressing the non-locking "ARTIST CALL" button on the No. D-87567 Apparatus Unit of the No. D-86852 Control Cabinet the No. E-241 Relay may be operated

at any time, thus disconnecting the output of the speech input equipment from the line to the input of the radio transmitter and extinguishing the "READY" lamps. When this is done the speech input equipment may be used as a local public address system for giving out information from any condenser transmitter which is connected to the amplifiers, through loud speaking telephones in any reception rooms or studios where there are no condenser transmitters which are connected to the amplifier, or for auditions or rehearsals.

The fourth mounting plate is a No. D-86778 Mounting Plate, mounting No. E-285 or No. R-333 Relays in positions 1 to 4. Each of these relays has its winding connected in series with the filament of the vacuum tube in one of the condenser transmitter amplifiers, so that when the filament circuit of the amplifier is closed by means of the associated No. 406-M Key on the No. 367-A Key Mounting, the relay operates, and its contacts, in closing, light a red-capped lamp immediately to the right of the No. 406-M Key which has been operated, to indicate that the amplifier is in operation.

The fifth mounting plate is a No. 600-A Mounting Plate which mounts six No. J-23 Relays in positions 1 to 6 and one No. B-9 Relay in position 10. Both the No. J-23 Relays and the No. B-9 Relay are part of the signalling system of the order wire lines associated with the outside program line circuits. The secondary winding of each No. J-23 Relay is connected, in series with a No. 57-A Condenser mounted on the No. D-88823 Power Panel, across one of the order wire circuits. When the operator at a remote point wishes to call the operator at the control room he connects the far end of the order wire line to a source of 20-cycle ringing current, which operates the associated No. J-23 Relay. Once operated, this relay is locked through its primary winding and its own contacts by current from the storage battery. This operation of a No. J-23 Relay lights a white-capped signal lamp in the No. 262 Lamp Socket Mounting directly over the jacks terminating the order wire line with which the relay is associated, thus indicating the call. The No. B-9 Relay is connected in series with the locking windings of the No. J-23 Relays and the signal lamps which are in parallel with them, so that it operates whenever one or more No. J-23 Relays are operated. The contacts of the No. B-9 Relay may be used to operate a buzzer in the control room telephone set, if such a buzzer is used, thus audibly notifying the Operator that a call is waiting.

Below the No. 600-A Mounting Plate is a blank mounting plate, below which is the No. D-85650 Panel which mounts the control room apparatus units of the studio control system and a monitor transfer key.

A No. D-87564 Apparatus Unit is mounted in position 1 of this panel. This unit contains a key to lock and unlock the control for the control room, a red-capped lamp which indicates when this control key is in the "ON" position and a white-capped lamp which indicates incoming phone calls on the studio interphone system. No. D-87565 Apparatus Units are provided for in positions 2 to 5. One of these units is mounted in position 2 in the standard equipment. This unit contains a locking key to lock and unlock the control for the associated

point of control together with a red-capped lamp to indicate when this control is unlocked, and a push button to enable the control room operator to call the point with which this unit is associated. A No. D-87569 Apparatus Unit is mounted in position 7. This unit contains a key which controls the operation of the No. E-241 Relay, already described, and a green-capped lamp which is lighted when the circuit is completed from the line amplifier through the No. E-241 Relay to the line to the radio transmitter. No. D-85644 Apparatus Units are provided in positions 8 to 13. Each of these units contains two push buttons and a red-capped lamp. One of the buttons when operated completes the circuit of the No. D-86880 (or No. D-87170) Relay and the No. R-1770 Relay, so as to connect the associated circuit to the amplifiers. The other button, when pressed, closes the circuit to the No. R-1086 Relay which opens the locking circuits of the switching relays. A red-capped lamp is also provided in each of these units to indicate when the associated relay circuit is operated. The remaining positions in this panel are equipped with No. D-86122 Apparatus Blanks.

A No. 479-G Key is provided at the right hand side of the No. D-85650 Panel to serve as the monitor transfer key referred to. This is a three-position lever unit key which locks in the position in which it is operated. This key may be used to switch the input of the monitoring amplifier from the output of the line amplifier to the output of a radio receiver or monitoring rectifier, or to disconnect the input circuit of the monitoring amplifier entirely.

Below the No. D-85650 Panel is a No. 884-F Mounting Plate on which are mounted the four No. D-90433 Potentiometers* associated with four condenser transmitter amplifier circuits. The output terminals of each condenser transmitter amplifier are connected, through jacks and relay contacts, to the input terminals of one of the four potentiometers. The outputs of the four potentiometers are connected in series to the input of the No. 8-C Amplifier. By means of these potentiometers it is possible to combine the outputs of two or more condenser transmitter amplifiers in any desired proportion, or to "fade" a program in or out on one channel without affecting transmission on the other channels.

Immediately below the potentiometers is the No. 367-A Key Mounting which contains four keys and five red-capped lamps. The keys are used to turn on and off the filament circuits of the condenser transmitter amplifiers. Directly to the right of each key is a red-capped lamp which lights when the associated amplifier is turned on. The fifth red-capped lamp serves as a fuse alarm and is so connected that it will light to indicate the burning-out of a No. 35-Type Fuse on the No. 204-A Panel of the No. D-88823 Power Panel.

Below the No. 367-A Key Mounting is a No. 184 Jack Mounting designated the "AMP. CUR." jack strip, which contains eight jacks, two of which are associated with each condenser transmitter amplifier so that the filament and plate currents of any of the four condenser transmitter amplifiers may be measured.

* Earlier No. D-87990 Miscellaneous Equipment Panels were equipped with No. D-85074 (Coded No. 33-A) Potentiometers.

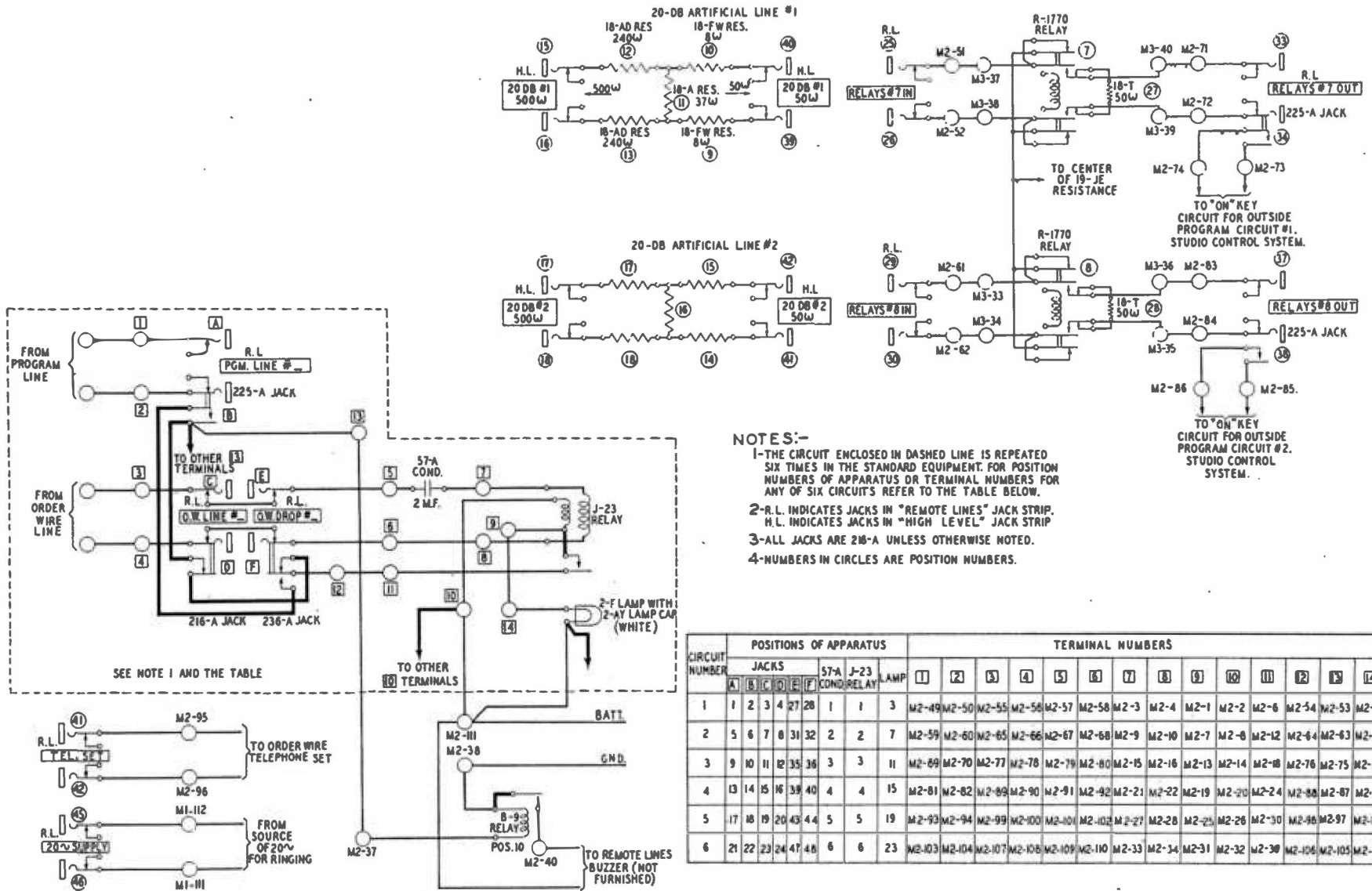

Schematic of Outside Line Control Circuits

Below the No. 184 Jack Mounting is the first No. 185 Jack Mounting designated the "LOW LEVEL" jack strip, which contains the jacks for switching and testing the low-level circuits; i.e., the local circuits on the input side of the No. 8-C amplifier. This jack strip contains the following jacks:

1. The output jacks for the four condenser transmitter amplifiers.
2. The input jacks for the four switching relay circuits which are associated with the four condenser transmitter amplifier circuits.
3. The input jacks for the four mixing potentiometers.
4. The jacks connected to the combined output of the four mixing potentiometers in series.
5. The input jacks of the No. 8-C Amplifier.
6. Two pairs of jacks which may be wired to the outputs of two additional condenser transmitter amplifiers.
7. Sixteen spare jacks which may be used for any special purpose desired.

Below the "LOW LEVEL" jack strip is a No. 262 Lamp Socket Mounting which contains the signal lamps associated with the order wire lines.

The second No. 185 Jack Mounting is designated the "REM. LINES" jack strip, and contains the following jacks:

1. The jacks terminating the six outside program lines.
2. The jacks terminating the six order wire lines associated with the outside program lines.
3. The input and output jacks for the two relay switching circuits which are associated with the outside program lines.
4. The jacks of the order wire drop or signalling circuits.
5. The jacks connected to the order wire telephone set and to the 20-cycle ringing current supply.

The third No. 185 Jack Mounting is designated the "HIGH LEVEL" jack strip, and contains all of the jacks for switching and testing the high level circuits; i.e., the circuits on the output side of the No. 8-C Amplifier. This jack strip contains the following jacks:

1. The output jacks for the No. 8-C Amplifier.
2. The input and output jacks for the No. 18-B Amplifier.
3. The input and output jacks for the No. E-241 Relay.
4. The input jacks for the volume indicator (No. 203-B Panel).
5. The input jacks to the wire line to the radio transmitter.
6. The output jacks for the radio receiver or monitoring rectifier if used.

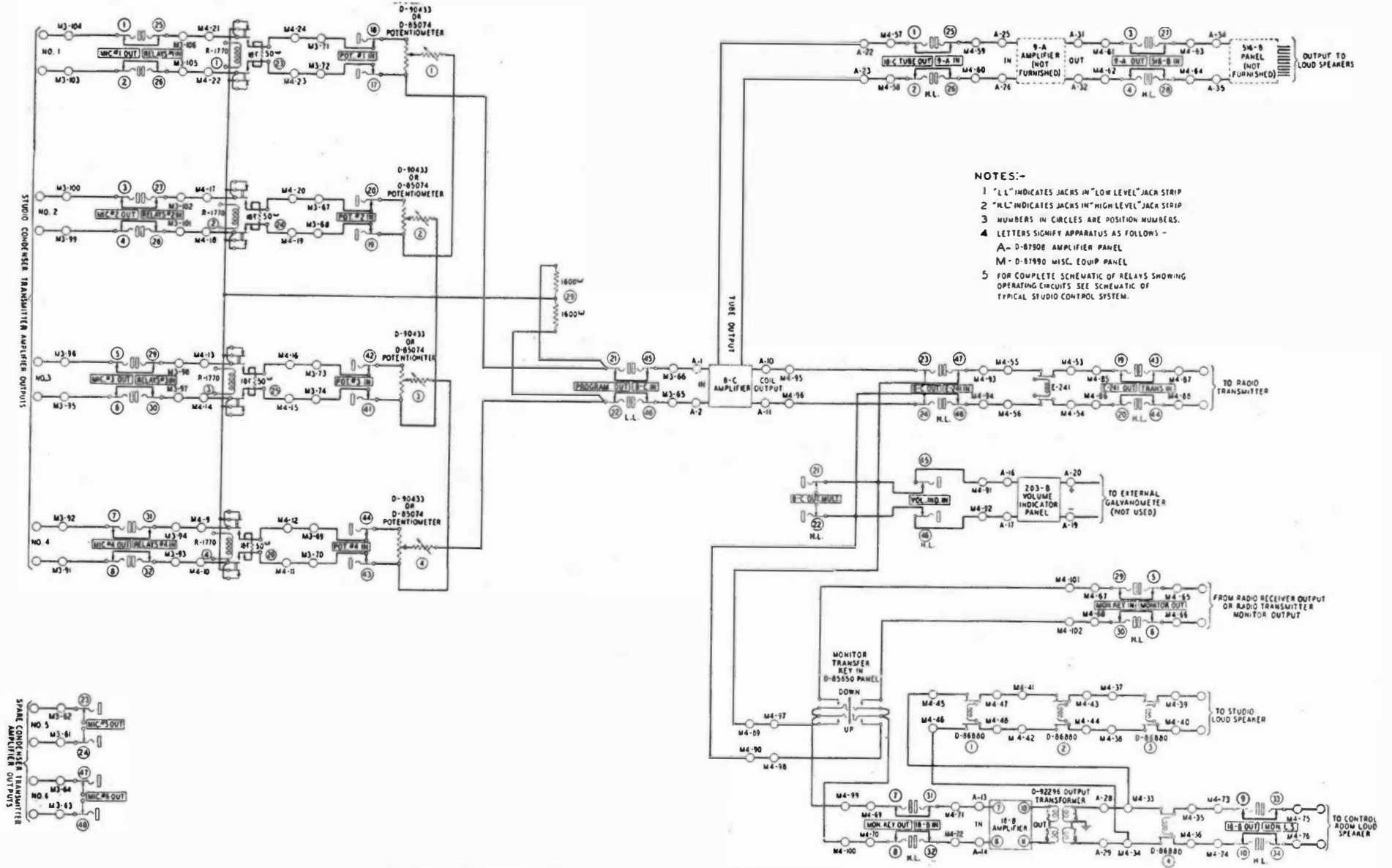

Schematic of Amplification and Gain Control Circuits

7. The input and output jacks for the monitor transfer key.
8. The jacks connected to the monitoring loud speaking telephone.
9. Jacks which are wired for use as input and output jacks for the No. 9-A Amplifier and input jacks for the No. 516-B Panel when these units are added to the speech input equipment.
10. The input and output jacks for the two 20-decibel artificial lines used with the outside program line circuits.
11. Eight spare jacks which may be used for any special purpose desired.

The position numbers on the jacks on the "REM. LINES" jack strip are shown on the schematic of outside line control circuits, pages 10 and 73, while those of the jacks on the other jack strips on the miscellaneous equipment panel are shown on the schematic of amplification and gain control circuits on pages 12 and 74. The designations of the jacks are shown on page 14.

Below the jack mountings is a blank mounting plate. Below this blank mounting plate is a No. D-86775 Mounting Plate on which are mounted the following resistances:

1. Six resistances, associated with the six switching relay circuits as previously described.
2. Ten resistances arranged to form the two 20-decibel artificial lines referred to in the preceding paragraph.
3. A resistance which may be included in the filament circuit of a Western Electric No. 4-D Radio Receiver so that the vacuum tube filaments of this receiver can be operated from the speech input equipment storage battery.
4. A center-tapped resistance which is associated with the mixing circuit and with the No. R-1770 Relays as a means of preventing clicks which otherwise might occur when these relays are operated.

NOTE. In some installations where the ground resistance is high it has been found necessary to shunt the break contacts of each No. R-1086 Relay with a resistance and a condenser in series, so that the opening of the relay contacts will not cause a click in the amplifier circuits. In order to care for such installations there is added to the No. D-87990 Miscellaneous Equipment Panels of the later No. 8-B Speech Input Equipments the following apparatus:

- 6—No. 18-G Resistances
- 6—No. 57-B Condensers
- 1—No. 884-C Mounting Plate

The No. 18-G Resistances are mounted with the other resistances on the No. D-86775 Mounting Plate on the No. D-87990 Miscellaneous Equipment Panel. The No. 57-B Condensers are mounted on the No. 884-C Mounting Plate, which is mounted on the No. D-87990 Miscellaneous Equipment Panel immediately above the No. D-86775 Mounting Plate.

Below the No. D-86775 Mounting Plate is a No. D-87339 Mounting Plate mounting four No. 51 Terminal Strips which contain the terminals for all of the apparatus mounted on this panel.

AMP. CUR.	MIC. #1		MIC. #2		MIC. #3		MIC. #4																		AMP. CUR.																							
	I _A	I _B	I _A	I _B	I _A	I _B	I _A	I _B	1	2	X	4	5	X	7	8	X	10	11	X	X	X	X	X		X	X	X	X	X	X	X																
LOW LEVEL	MIC. #1 OUT.		MIC. #2 OUT.		MIC. #3 OUT.		MIC. #4 OUT.								POT. #1 IN.		POT. #2 IN.		PROGRAM OUT.		MIC. #5 OUT.		LOW LEVEL																									
	RELAYS #1 IN.		RELAYS #2 IN.		RELAYS #3 IN.		RELAYS #4 IN.								POT. #3 IN.		POT. #4 IN.		8-C IN.		MIC. #6 OUT.																											
	1	2	3	4	5	6	7	8	9	10	11	12	13	14	15	16	17	18	19	20	21	22		23	24	25	26	27	28	29	30	31	32	33	34	35	36	37	38	39	40	41	42	43	44	45	46	47
O.W. LAMPS	ORDER WIRE #1 LAMP		ORDER WIRE #2 LAMP		ORDER WIRE #3 LAMP		ORDER WIRE #4 LAMP		ORDER WIRE #5 LAMP		ORDER WIRE #6 LAMP																		O.W. LAMPS																			
	X	X	3	X	X	X	7	X	X	X	11	X	X	X	13	X	X	X	17	X	X	X	23	X																								
REM. LINES	PGM. LINE #1		O.W. LINE #1		PGM. LINE #2		O.W. LINE #2		PGM. LINE #3		O.W. LINE #3		PGM. LINE #4		O.W. LINE #4		PGM. LINE #5		O.W. LINE #5		PGM. LINE #6		O.W. LINE #6		REM. LINES																							
	RELAYS #7 IN.		O.W. DROP #1		RELAYS #8 IN.		O.W. DROP #2		RELAYS #7 OUT.		O.W. DROP #3		RELAYS #8 OUT.		O.W. DROP #4		TEL. SET.		O.W. DROP #5		20~ SUPPLY		O.W. DROP #6																									
	1	2	3	4	5	6	7	8	9	10	11	12	13	14	15	16	17	18	19	20	21	22	23	24		25	26	27	28	29	30	31	32	33	34	35	36	37	38	39	40	41	42	43	44	45	46	47
HIGH LEVEL	8C TUBE OUT.		9A OUT.		MONITOR OUT.		MON. KEY OUT.		18B OUT.						20DB #1		20DB #2		E241 OUT.		8C OUT. MULT.		8C OUT.		HIGH LEVEL																							
	9A IN.		516B IN.		MON. KEY IN.		18B IN.		MON. L.S.T.						50W		50W		TRANS. IN.		VOL. IND. IN.		E241 IN.																									
	1	2	3	4	5	6	7	8	9	10	11	12	13	14	15	16	17	18	19	20	21	22	23	24		25	26	27	28	29	30	31	32	33	34	35	36	37	38	39	40	41	42	43	44	45	46	47

NOTES:—1—FRONT VIEW OF JACK ASSEMBLY IS SHOWN.
 2—'X' INDICATES POSITION EQUIPPED WITH APPARATUS BLANK.

Jack Strip Designations

No. D-88823 Power Panel

The power panel, like the amplifier panel and the miscellaneous equipment panel, is assembled on a framework at the factory. This panel, illustrated on pages 16 and 17, contains the following apparatus associated with the power supply circuits of the speech input equipment:

1. A No. 204-A Panel (Battery Fuse Panel) containing the No. 35-Type Fuses for the circuits supplied from the equipment storage batteries and a switch for disconnecting the battery from these circuits. A fuse-alarm bus on the No. 204-A Panel is wired to the red-capped fuse-alarm lamp in position 16 of the No. 367-A Key Mounting on the No. D-87990 Miscellaneous Equipment Panel. (The No. 35 Type Fuses are so constructed that the burning of the fuse wire allows a contact finger which is a part of the fuse to make contact with the fuse alarm bus so that the fuse-alarm lamp will light whenever a fuse on the No. 204-A Panel burns out.)

2. A No. D-89687 Mounting Plate mounting four rheostats which are used to control the filament currents of the four condenser transmitter amplifiers. These rheostats were not included in earlier No. D-88823 Power Panels.

3. A No. 1-B Rectifier for supplying high voltage direct current to the plate circuits of the vacuum tubes in the amplifiers and in the volume indicator, and for maintaining the necessary difference of potential between the electrodes of the condenser transmitters.

4. A No. D-86777 Mounting Plate on which are mounted eight Ward-Leonard resistances. Two of these resistances comprise a voltage divider or potentiometer for reducing the 350 volts from the output of the No. 1-B Rectifier to a value suitable for the plate circuit of the vacuum tube in the volume indicator (No. 203-B Panel); two more resistances comprise another similar voltage divider for supplying a voltage suitable for the condenser transmitters and associated amplifiers, and the others are used as compensating load resistances to absorb the excess power delivered by the rectifier unless the No. 9-A Amplifier is used.

5. A No. 884-C Mounting Plate on which are mounted nine No. 57-A Condensers. Six of these condensers are used in the order wire drop circuits, two are part of the auxiliary filter for the high voltage supply to the condenser transmitters and associated amplifiers, and the remaining one is in parallel with that part of the voltage divider or potentiometer, referred to in the preceding paragraph, which is connected in parallel with the plate voltage supply to the volume indicator.

6. A No. D-86776 or No. D-90758 Mounting Plate on which is mounted the No. 54-L Retardation Coil, used to supply battery and ground to the inter-phone circuits, and the No. 75-A or No. 148-A Retardation Coil which is part of the filter for the high voltage supply to the condenser transmitters and associated amplifiers.

A schematic of the power supply circuits, which include the apparatus on the No. D-88823 Power Panel, is shown on pages 18 and 75.

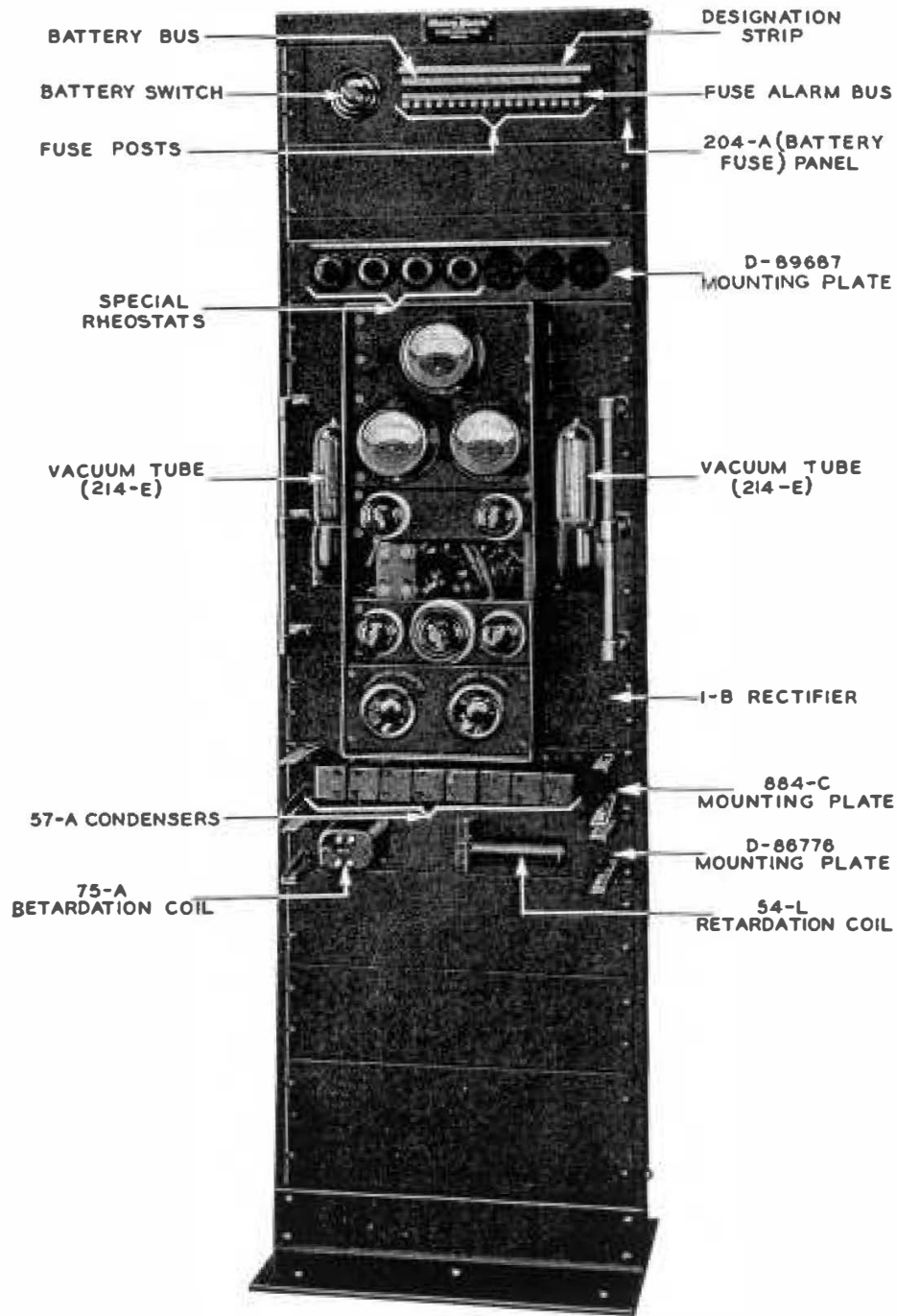

No. D-88823 Power Panel—Front View

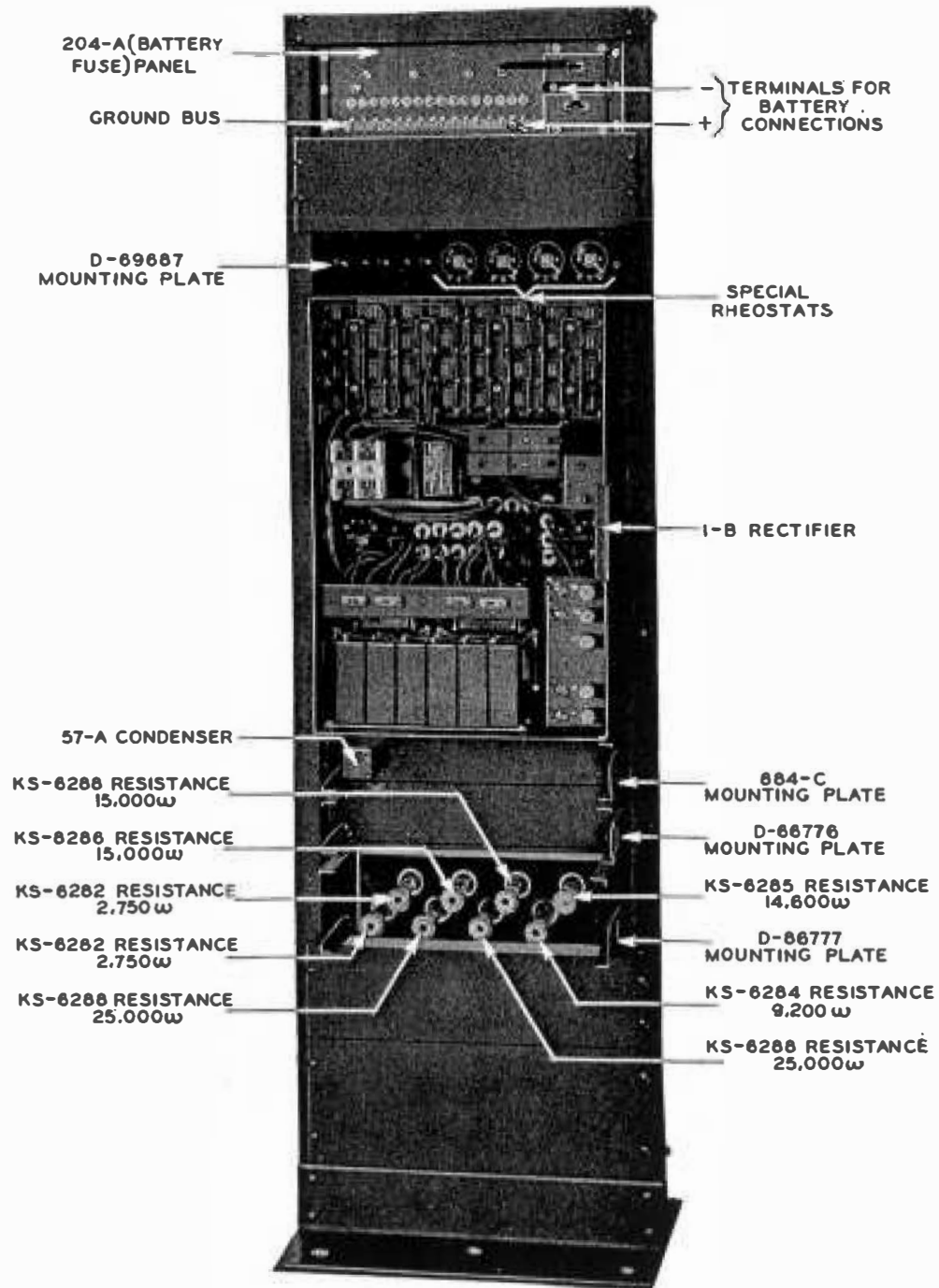

No. D-88823 Power Panel—Rear View

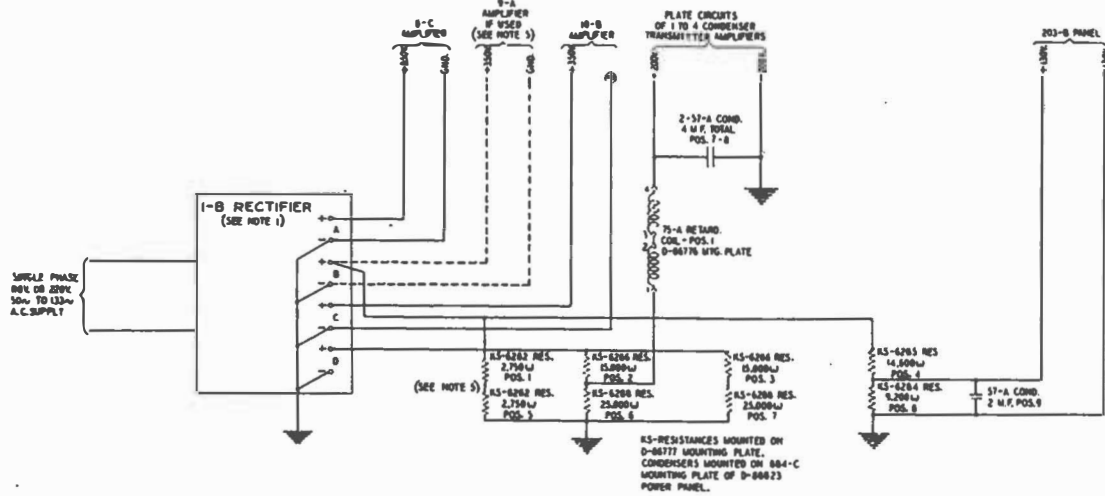

NOTES:-

- 1 - WHEN I-B RECTIFIER IS USED ON 60 VOLT A.C. SUPPLY STRAP 1-2 AND 3-4 ON EACH TRANSFORMER TERMINAL BLOCK OF THE RECTIFIER ON 220 VOLT A.C. SUPPLY STRAP 2-3 ONLY ON EACH TRANSFORMER TERMINAL BLOCK.
- 2 - THE FOLLOWING TUNGAR RECTIFIERS WILL BE FURNISHED WHEN POWER SUPPLY IS AS INDICATED
 105/123 V. 50-60 ~ RS-5194, LIST NO. 1 (E.C. CAT. # 312127)
 220/250 V. 50-60 ~ RS-5194, LIST NO. 3 (E.C. CAT. # 312129)
- 3 - LETTERS IN CIRCLES (THIS Ⓞ) ARE CODE LETTERS OF 25 TYPE FUSES AS FOLLOWS:-
 25-A-15 AMP-WHITE BEAD
 30-C-2 AMP-YELLOW BEAD
 25-D-10 AMP-RED BEAD
 25-G-3 AMP-BLUE BEAD
 35-H-5 AMP-GREEN BEAD
- 4 - POSITION NUMBERS REFER TO MOUNTING POSITIONS ON THE MOUNTING PLATES OF THE EQUIPMENT AS INDICATED.
- 5 - THE 9-A AMPLIFIER IS NOT FURNISHED AS A PART OF THE 9-B SPEECH INPUT EQUIPMENT. WHEN THIS AMPLIFIER IS ADDED TO THE EQUIPMENT THE RS-RESISTANCES IN POSITIONS 1 & 5 ON THE D-8677 MOUNTING PLATE SHOULD BE REORDERED.

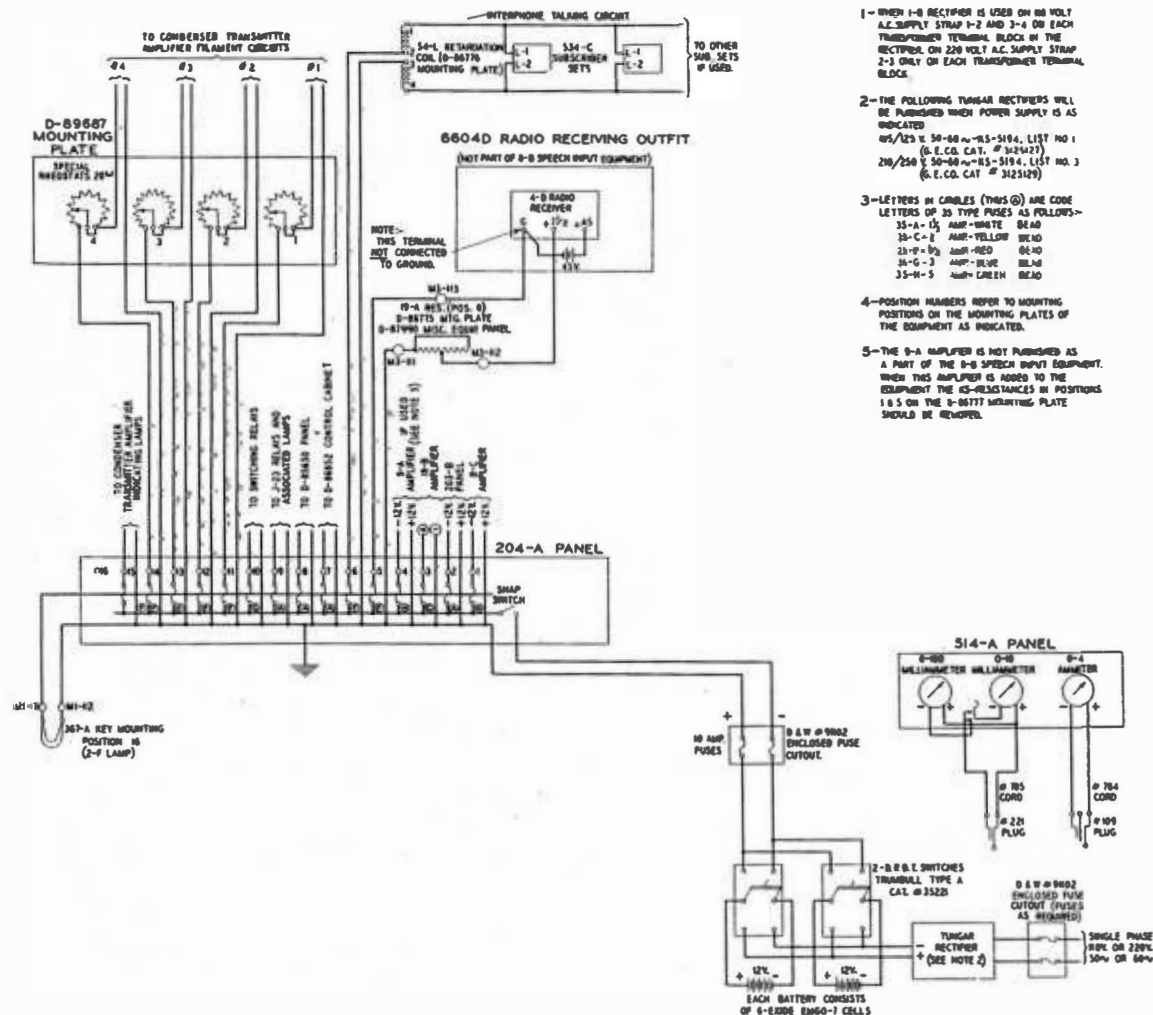

Schematic of Power Supply Circuits

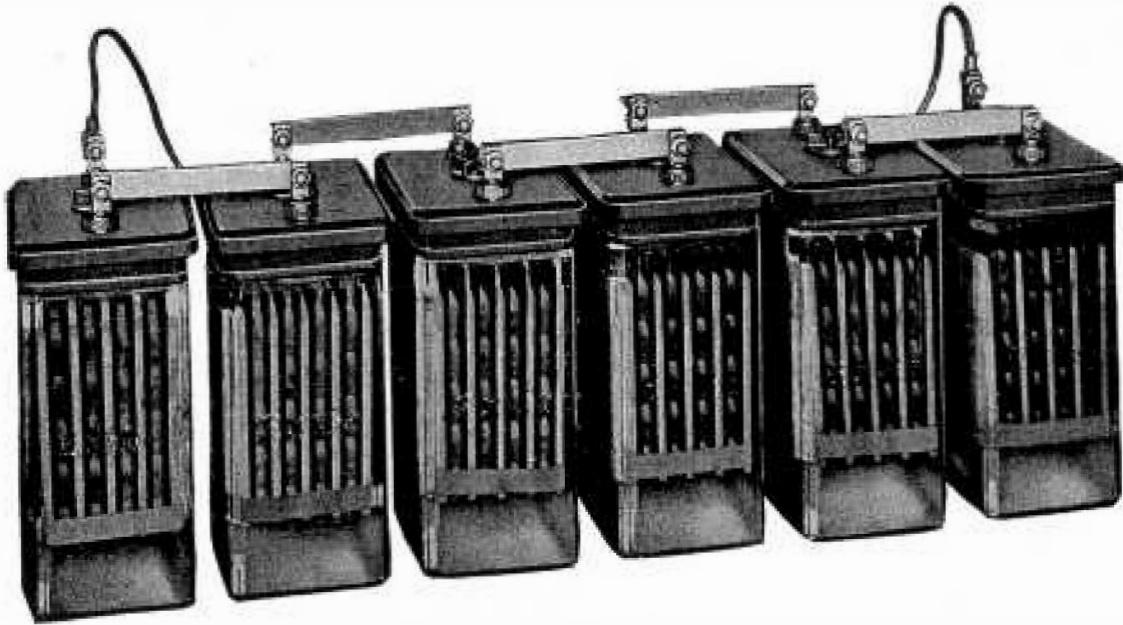

Typical Storage Battery Installation

FILAMENT POWER SUPPLY

Batteries

Two storage batteries, consisting of long-life glass jar cells of the type used in telephone exchanges, are furnished to supply power to the relays, signal lamps and vacuum tube filaments. These batteries have adequate capacity to operate the equipment for 18 consecutive hours out of every 24-hour period if the charge and discharge cycles shown below are followed. In installa-

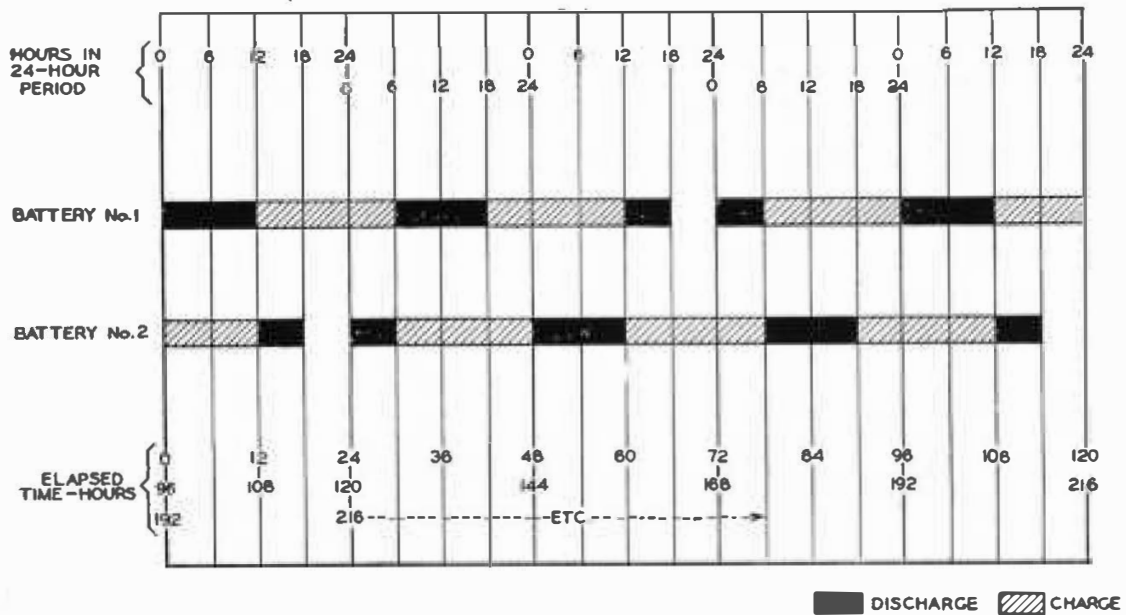

Battery Charge and Discharge Cycles

tions where the No. 9-A Amplifier is added to the equipment it will be necessary to provide additional ampere-hour capacity in the filament power storage batteries. This can be accomplished economically by the use of larger plate assemblies in the original glass jars. A typical battery installation, with one battery only, is shown on page 19.

Charging Equipment

A Tungar Rectifier of suitable capacity is furnished as part of the equipment for recharging the storage batteries. Two double pole, double throw safety switches are provided so that either battery may be connected to the charging equipment or to the discharge circuit or may be disconnected entirely. Also, if necessary, both batteries may be charged in parallel or, in an emergency, both may be discharged in parallel. A schematic of the power supply circuits is shown on page 18.

CONDENSER TRANSMITTERS AND ASSOCIATED EQUIPMENT

Four condenser transmitters are furnished as part of the No. 8-B Speech Input Equipment, together with four amplifiers designed to work in conjunction with the condenser transmitters, and four transmitter mountings. Each transmitter mounting is designed to mount one condenser transmitter and one amplifier. Cords are provided for interconnecting the transmitter and amplifier and for connecting the amplifier to a base board outlet.

The condenser transmitter used is the No. 394 Transmitter, illustrated below. This transmitter consists of a very thin, tightly stretched metal diaphragm, mounted closely adjacent to but not touching a flat metal plate. The diaphragm and the plate are insulated from each other, and constitute the two electrodes of a small air-dielectric condenser whose capacity is varied by sound waves striking the diaphragm. The air space between the diaphragm and the

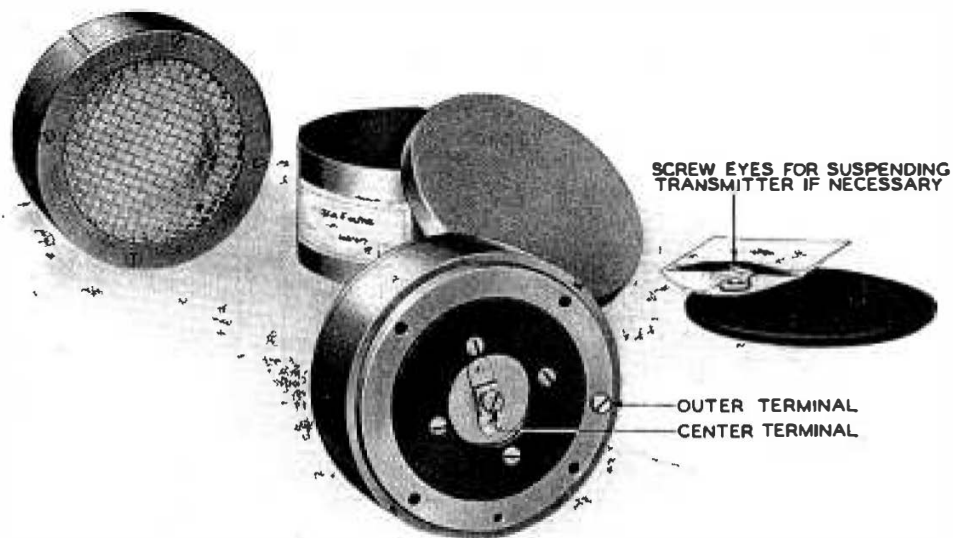

No. 394 Transmitter with Shipping Box

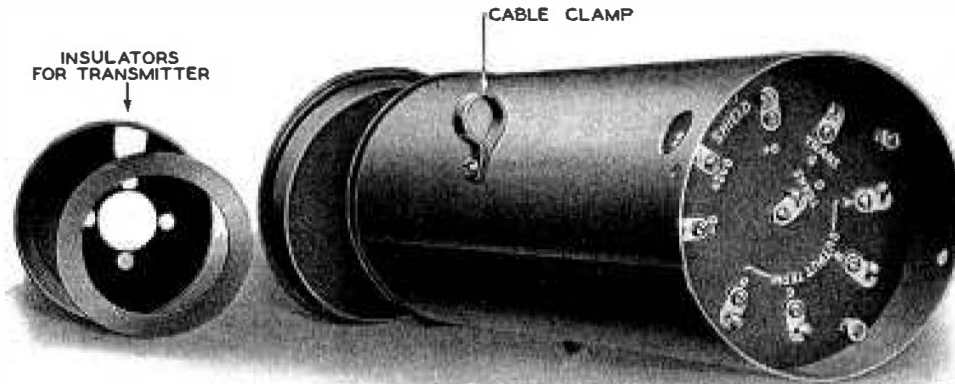

No. 47-B Condenser Transmitter Amplifier

plate is separated from the outside air by a flexible compensating diaphragm which equalizes the air pressure on the two sides of the main diaphragm for any atmospheric pressure equivalent to not more than 3 inches of mercury above or below normal pressure at sea level.

As the condenser transmitter has an extremely high impedance it cannot be coupled directly to the input of the main speech input amplifier. The condenser transmitter amplifier is, therefore, used as an impedance translating device to operate between the high impedance of the condenser transmitter and the low impedance of the main amplifier input circuit, and at the same time to amplify to some extent the very small amount of power developed by the condenser transmitter. The condenser transmitter amplifier is supplied in two forms, differing in mechanical arrangement but electrically identical. The No. 47-B Amplifier is shown above, and the No. 48-A Amplifier is shown on page 23.

The transmitter mountings supplied with this equipment are of two types, two of each type being furnished. The No. 7-A Transmitter Mounting shown on page 23 is a cast aluminum mounting, finished in black lacquer and designed to be used on a desk or table. This mounting mounts the No. 394 Transmitter and the No. 48-A Amplifier which are connected by a No. T2E Cord 4 inches long. The No. 8-A Transmitter Mounting shown on page 24 is an adjustable floor type mounting finished in dull black japan. This mounting mounts the No. 394 Transmitter and the No. 47-B Amplifier which are connected by a No. T2E Cord 5 feet long. The complete assembly of transmitter and amplifier in either type mounting is connected to the base board outlet, which is a No. 369 or No. 370 Jack, by means of a No. M6B Cord 12 feet long terminated in a No. 253-A Plug.

A schematic diagram showing the connection of the transmitter, the amplifier, the cords and the baseboard outlet is shown on pages 22 and 76 and a schematic diagram of the condenser transmitter amplifier control circuits is shown on pages 25 and 77.

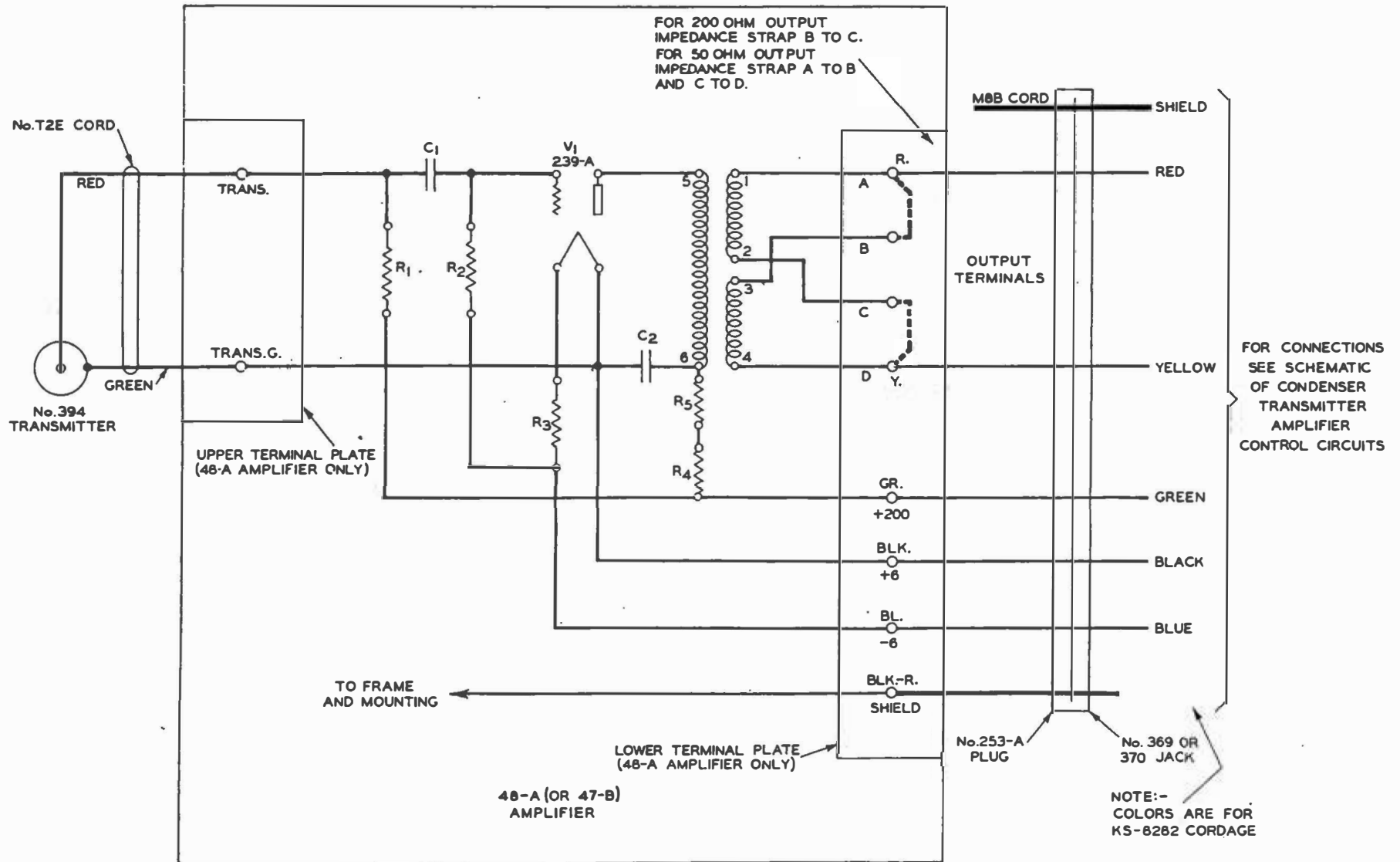

Schematic of No. 394 Transmitter and Associated Amplifier and Diagram of External Connections

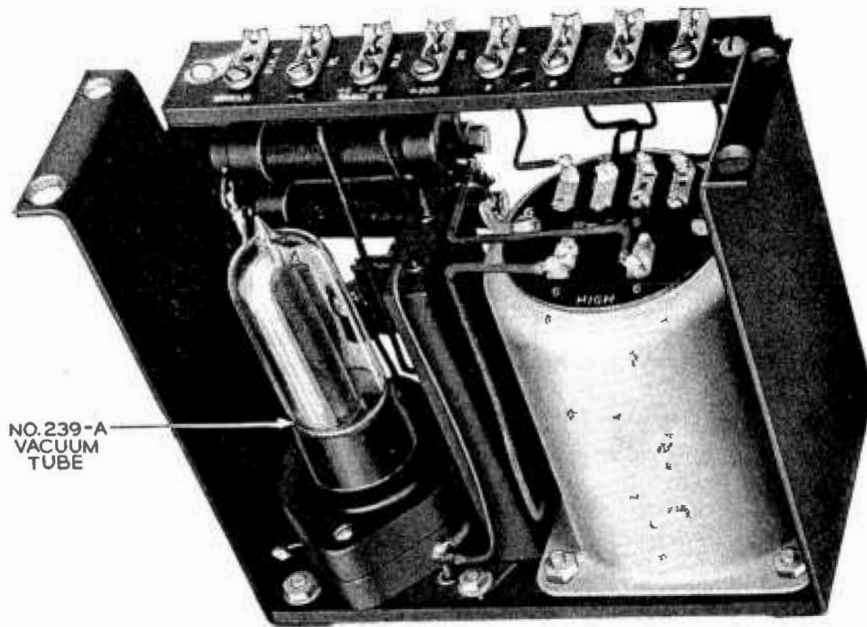

NO. 239-A
VACUUM
TUBE

No. 48-A Condenser Transmitter Amplifier

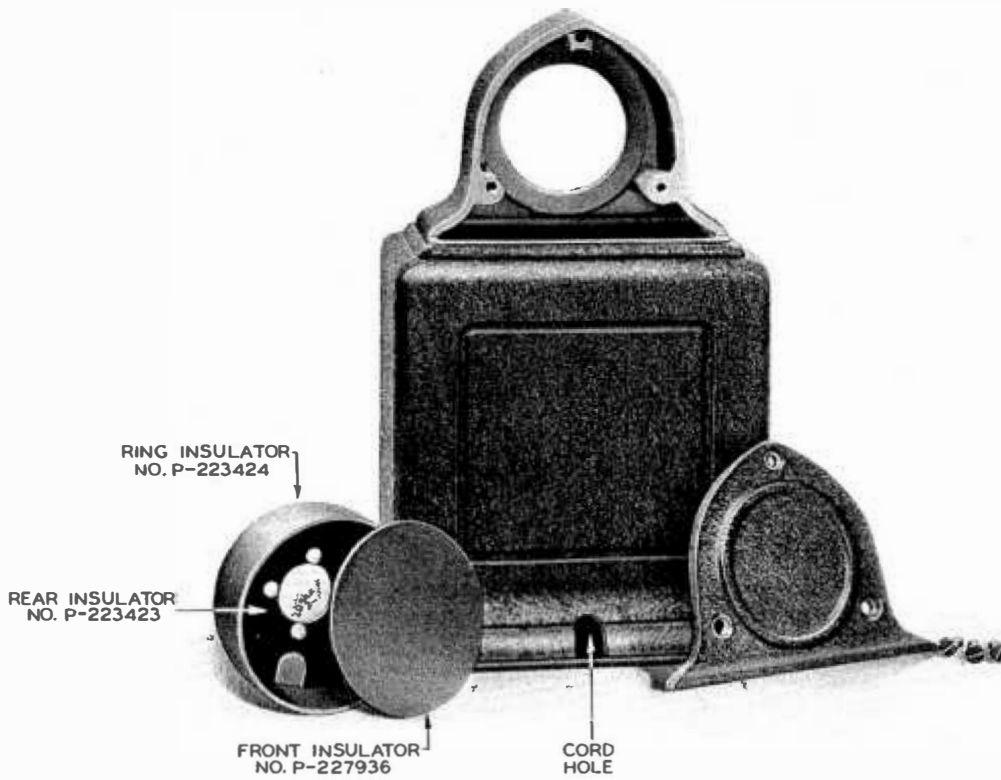

RING INSULATOR
NO. P-223424

REAR INSULATOR
NO. P-223423

FRONT INSULATOR
NO. P-227936

CORD
HOLE

No. 7-A Transmitter Mounting



No. 8-A Transmitter Mounting

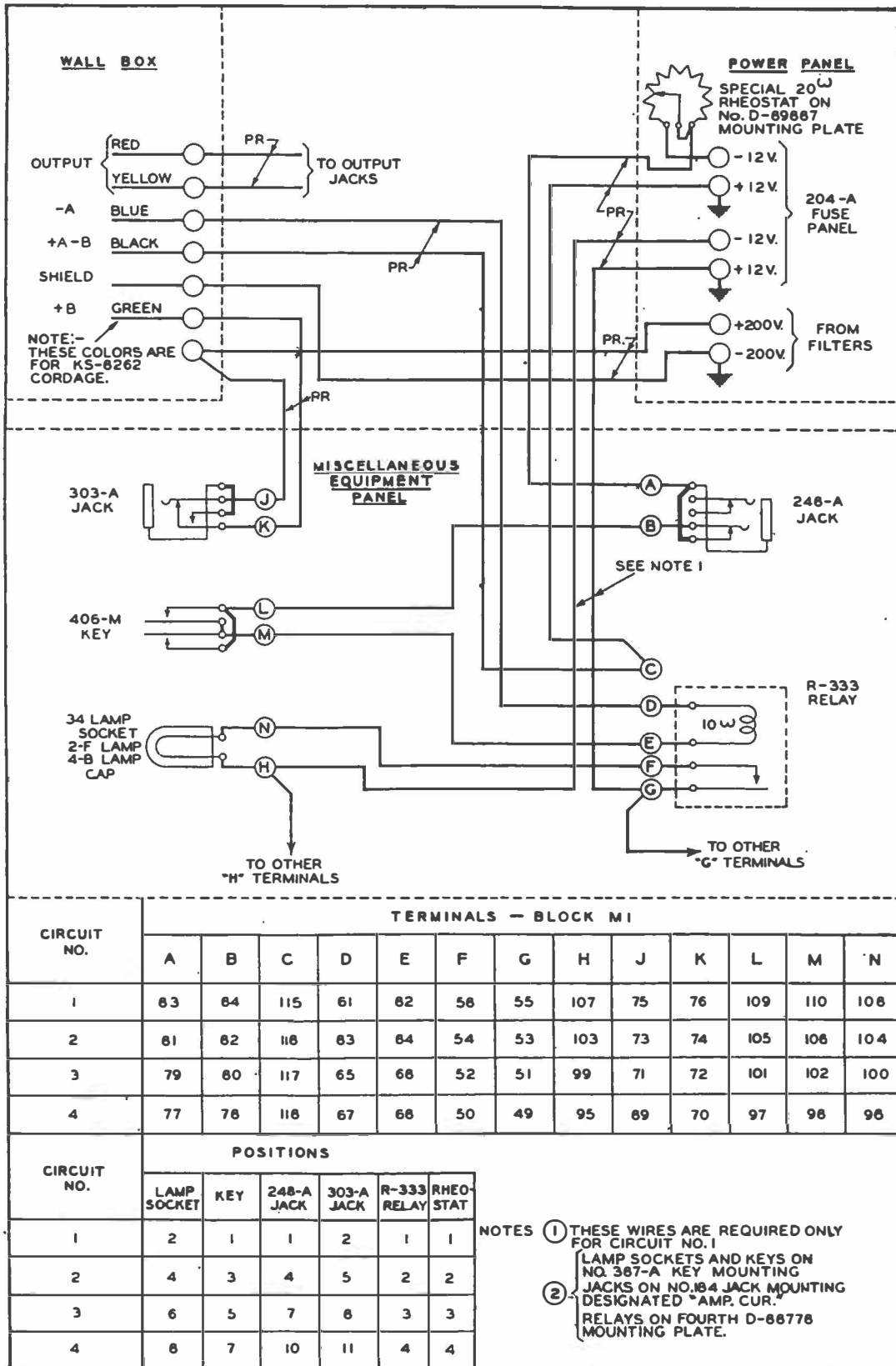

Schematic of Condenser Transmitter Amplifier Control Circuits

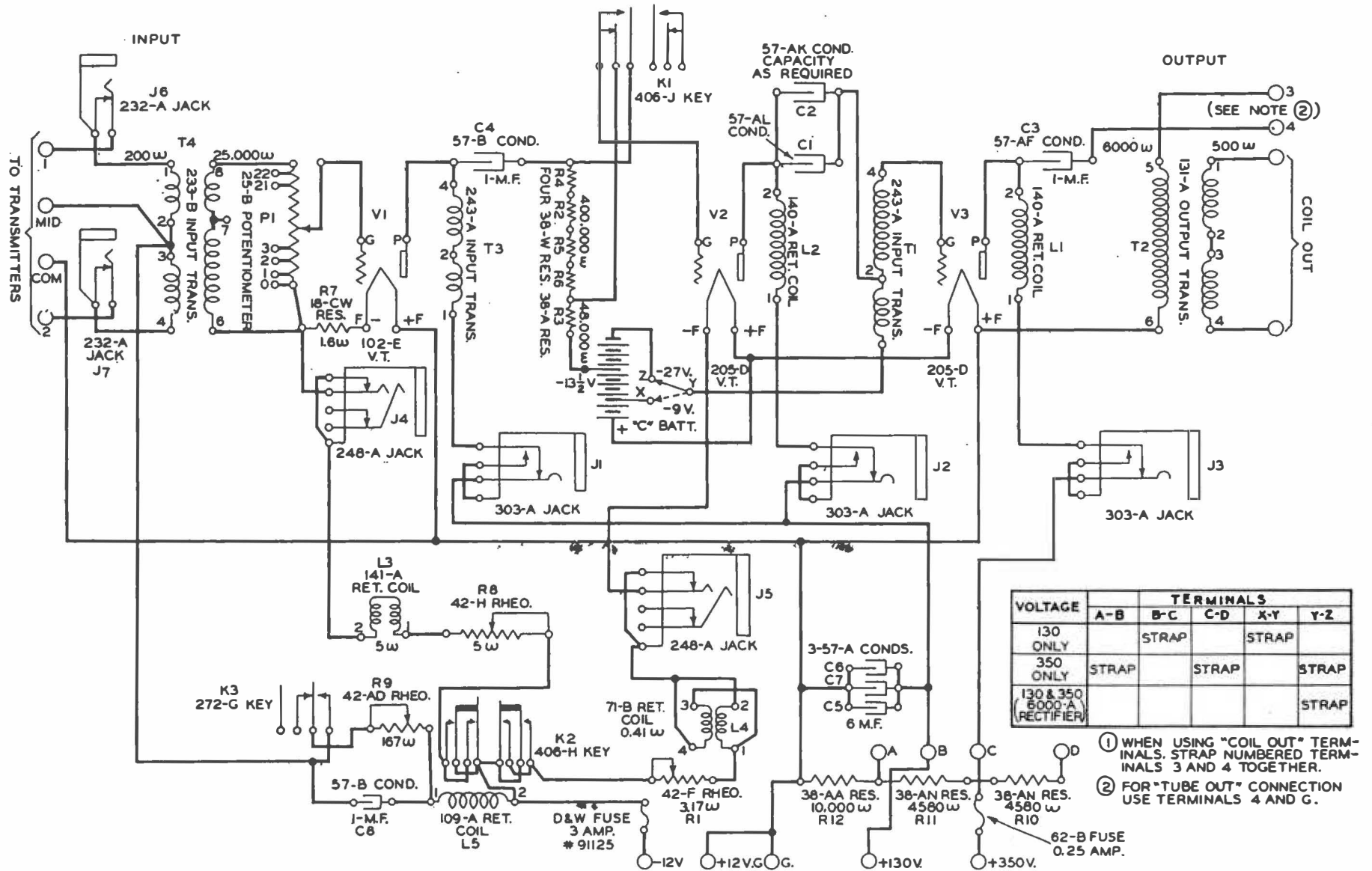

Schematic of No. 8-C Amplifier

APPARATUS ON PANEL ASSEMBLIES

No. 8-C Amplifier

This amplifier, illustrated on pages 28 and 29, is provided as the main or line amplifier to amplify the program material from the condenser transmitters or remote program lines before it is sent to the radio transmitter. It is a three stage amplifier using a No. 102-G Vacuum Tube* in the first stage and a No. 205-D Vacuum Tube in each of the other two stages. The filaments of the vacuum tubes are supplied from the equipment storage battery, through a 3-ampere fuse (No. 35-G Fuse) in position 1 on the No. 204-A Panel which is part of the No. D-88823 Power Panel. Filament rheostats to adjust the filament currents to the proper value are provided, together with jacks to receive the plugs at the ends of the cords of the No. 514-A Panel, so that both the filament and plate currents of each of the three vacuum tubes may be measured. Power for the plate circuits of the vacuum tubes in this amplifier is supplied from the "A" terminals of the No. 1-B Rectifier, and controlled by the upper left-hand switch on the rectifier. The plate circuit of the No. 205-D Vacuum Tube in the last stage is supplied with 350 volts directly from the output of the No. 1-B Rectifier. A voltage divider which is a part of the amplifier reduces the 350 volts from the rectifier to approximately 130 volts for the plate circuits of the No. 102-G Vacuum Tube in the first stage and the No. 205-D Vacuum Tube in the second stage.

A battery box on the panel of this amplifier holds six No. 703 Eveready dry batteries which supply 27 volts and 13.5 volts negative potential to the grids of the vacuum tubes in the third and second stages respectively. The grid of the first stage vacuum tube receives its negative potential from the voltage drop in a resistance in the negative filament lead of this vacuum tube.

A twenty-two step potentiometer, mounted on the front of the amplifier and connected in the grid circuit of the first stage vacuum tube, is the main gain control of the speech input equipment. In addition a "HIGH-LOW" switch on the front of the amplifier, associated with a two-step potentiometer in the grid circuit of the second stage vacuum tube, provides two ranges of adjustment for the main potentiometer. On the terminal strip at the rear of this amplifier the terminals marked "COIL OUT" are from the secondary of the output transformer, and are connected to the input of the volume indicator, to the input of the monitoring amplifier and through the contacts of the No. E-241 Relay to the wire line to the radio transmitter. The terminals marked "4" and "G" are connected directly in the plate circuit of the last amplifier tube, and are to be connected to the input of a power amplifier (No. 9-A Amplifier) when such an amplifier is added to the equipment. A simplified circuit of the No. 8-C Amplifier is shown on pages 26 and 78 and the wiring diagram is shown on page 79.

* The No. 102-E Vacuum Tube, supplied with earlier equipments, has been replaced by the No. 102-G Vacuum Tube. The Nos. 102-E and 102-G Vacuum Tubes are entirely interchangeable in this equipment.

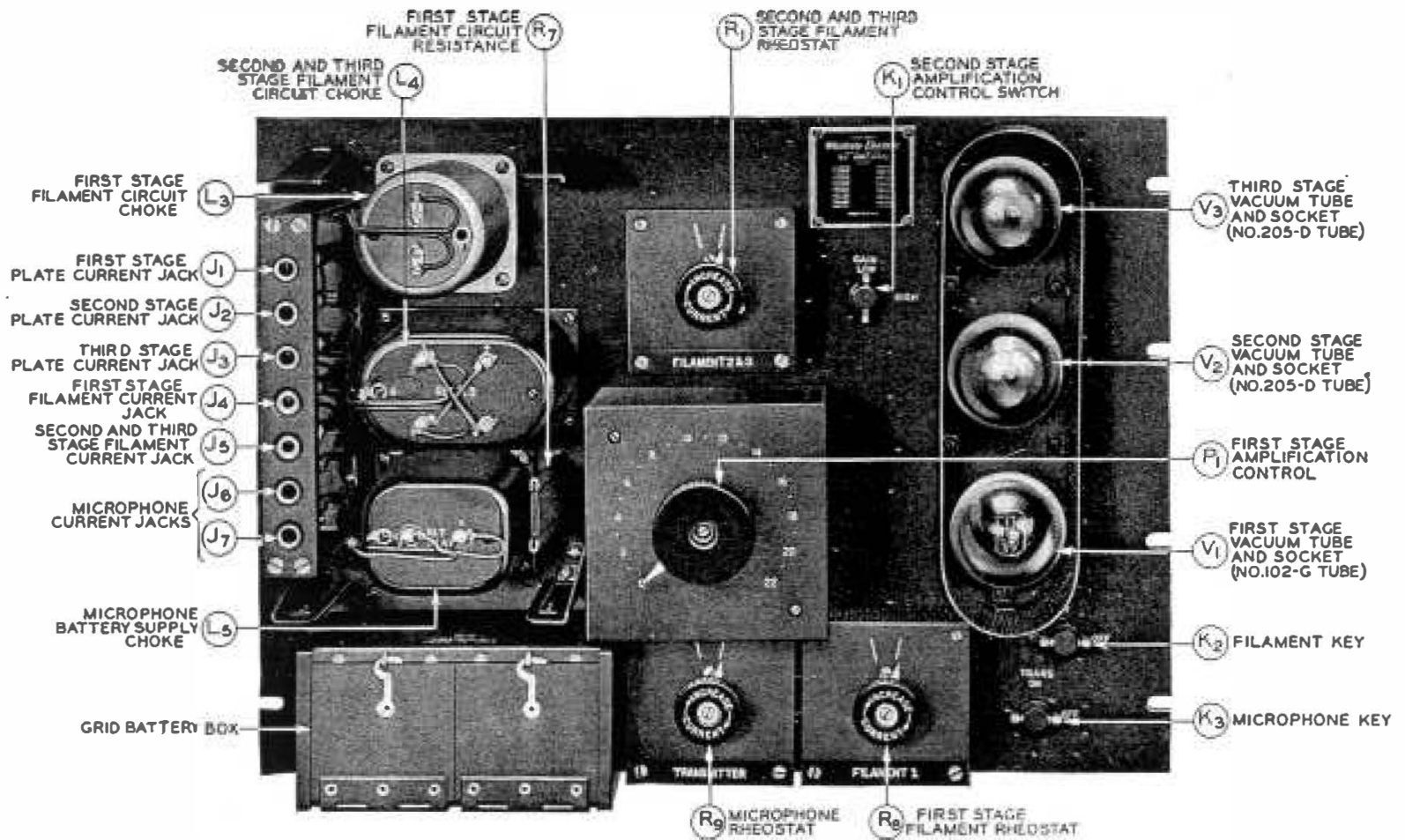

No. 8-C Amplifier—Front View

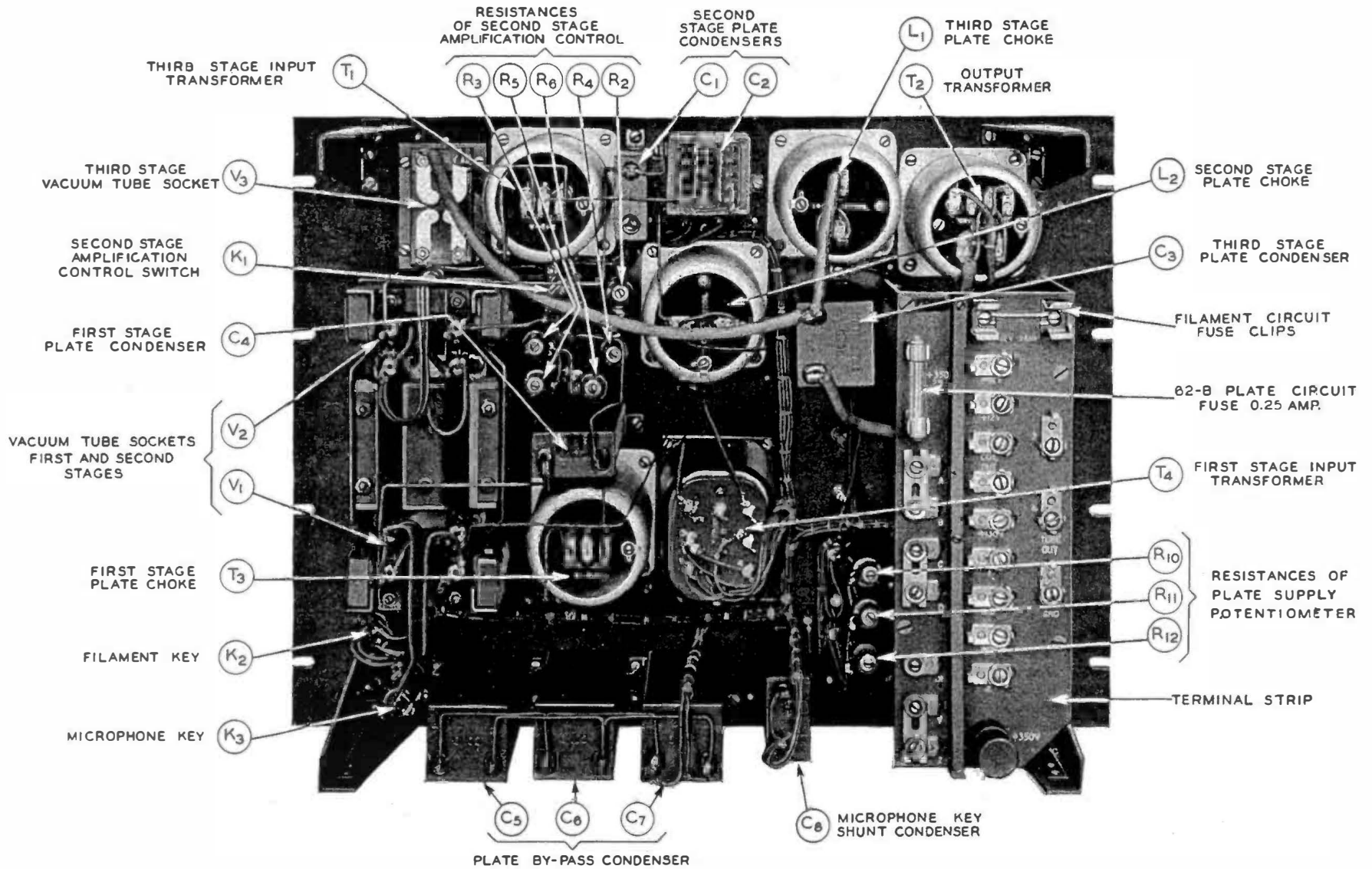

No. 8-C Amplifier—Rear View

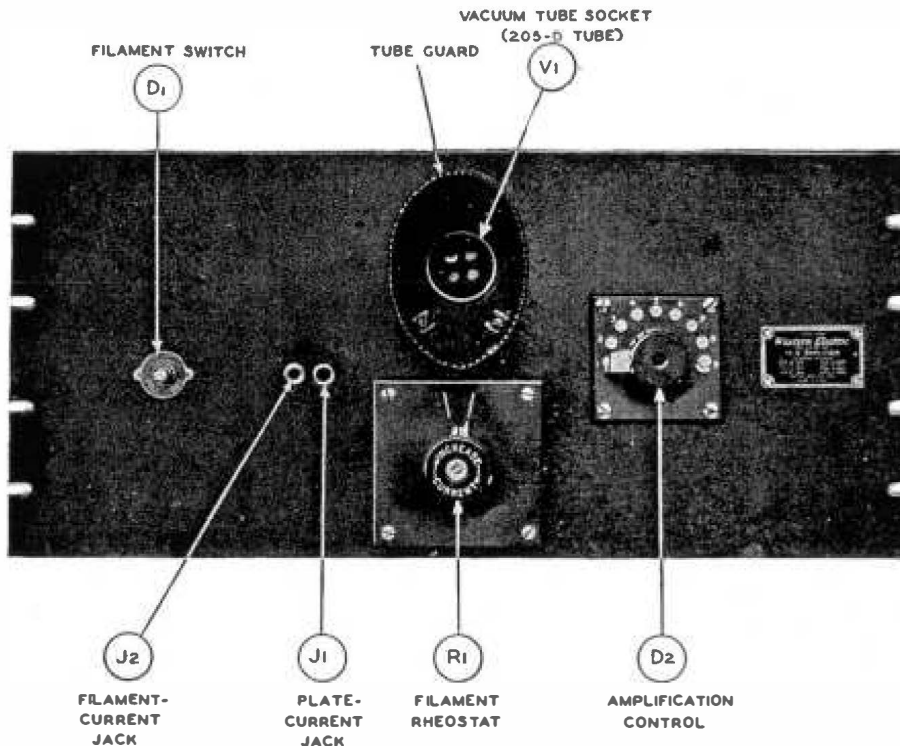

No. 18-B Amplifier—Front View

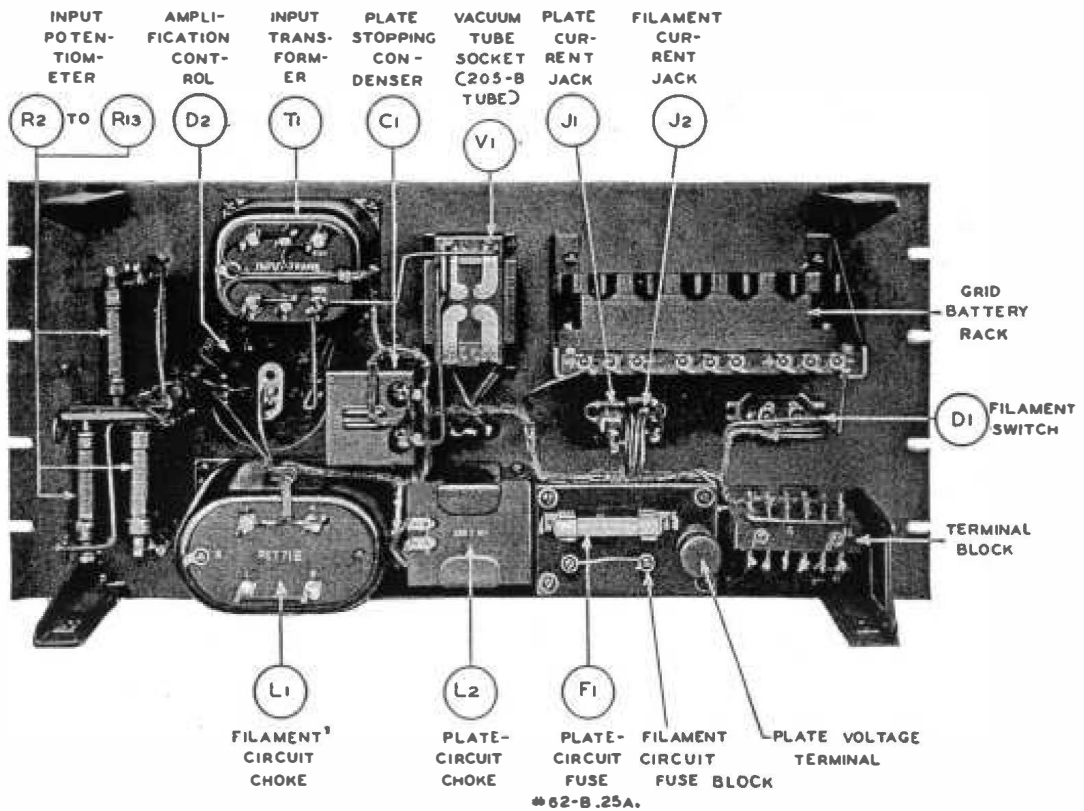

No. 18-B Amplifier—Rear View

No. 18-B Amplifier

The No. 18-B Amplifier, which is shown on page 30, is provided for monitoring. It is a single stage amplifier using one No. 205-D Vacuum Tube and is used to operate one or two No. 560-Type Loud Speaking Telephones. The gain control potentiometer of this amplifier permits adjustment of the output to a level suitable for monitoring when the output of the No. 8-C Amplifier is maintained at the level ordinarily used in supplying the radio transmitter. By means of the monitor transfer key on the No. D-85650 Panel of the No. D-87990 Miscellaneous Equipment Panel, the input of this amplifier may be connected either to the input of the radio transmitter or to the output of a radio receiver or monitoring rectifier.

The filament circuit of this amplifier is supplied through a 2-ampere fuse (No. 35-C Fuse) in position 3 on the No. 204-A Panel which is part of the No. D-88823 Power Panel. The plate circuit of this amplifier is supplied from the "C" terminals of the No. 1-B Rectifier. As in the No. 8-C Amplifier, jacks are provided for measuring the filament and plate currents, together with a rheostat for adjusting the filament current to the proper value. Six No. 703 Eveready dry batteries are mounted in a battery rack on the rear of the amplifier to

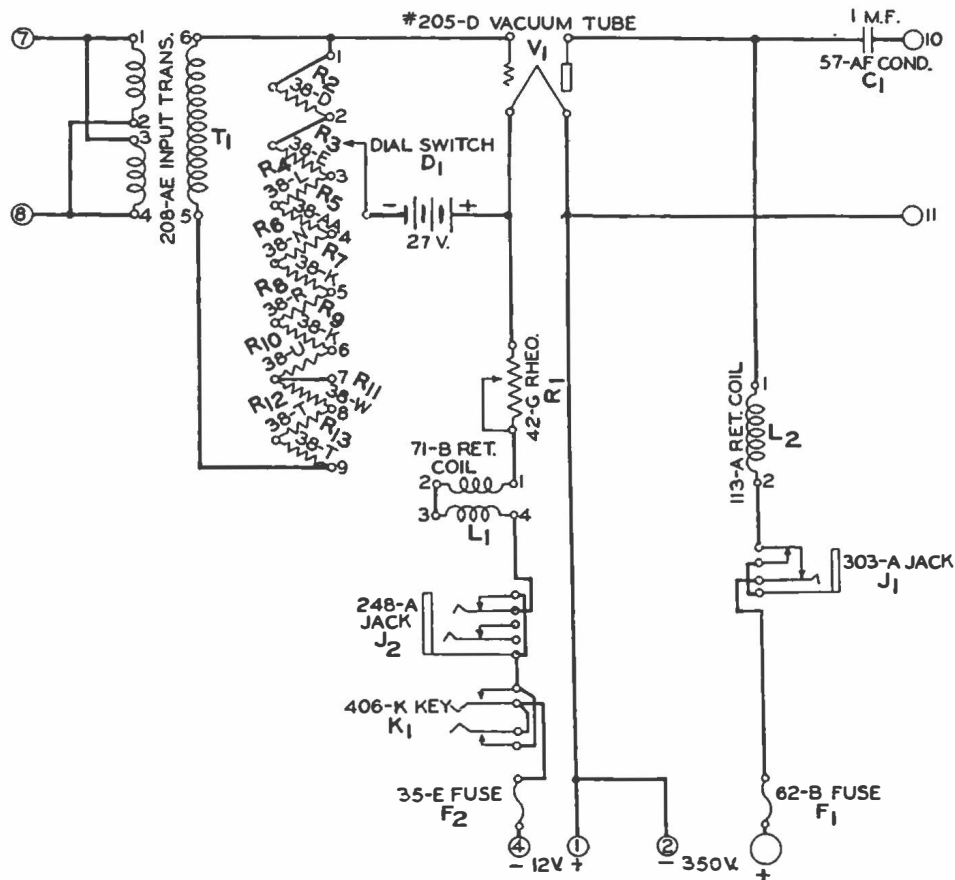

Schematic of No. 18-B Amplifier

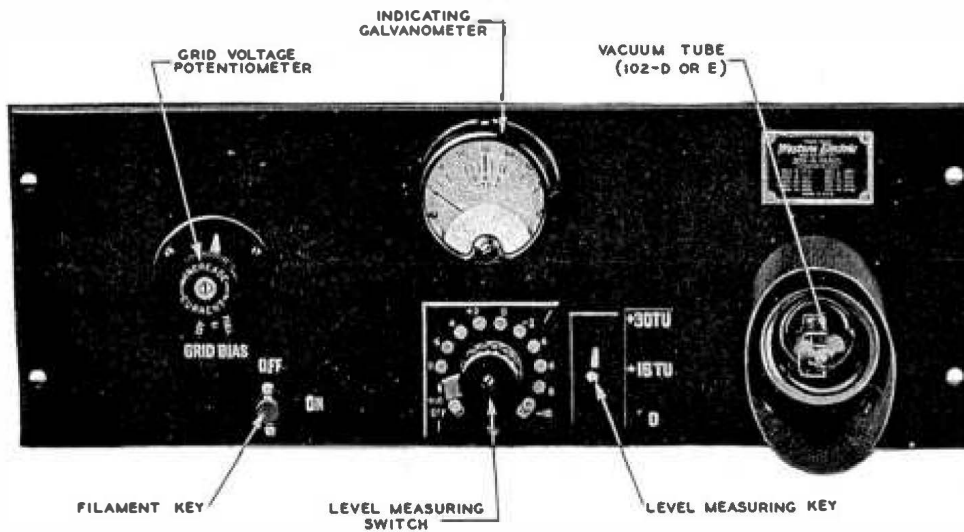

No. 203-B Panel—Front View

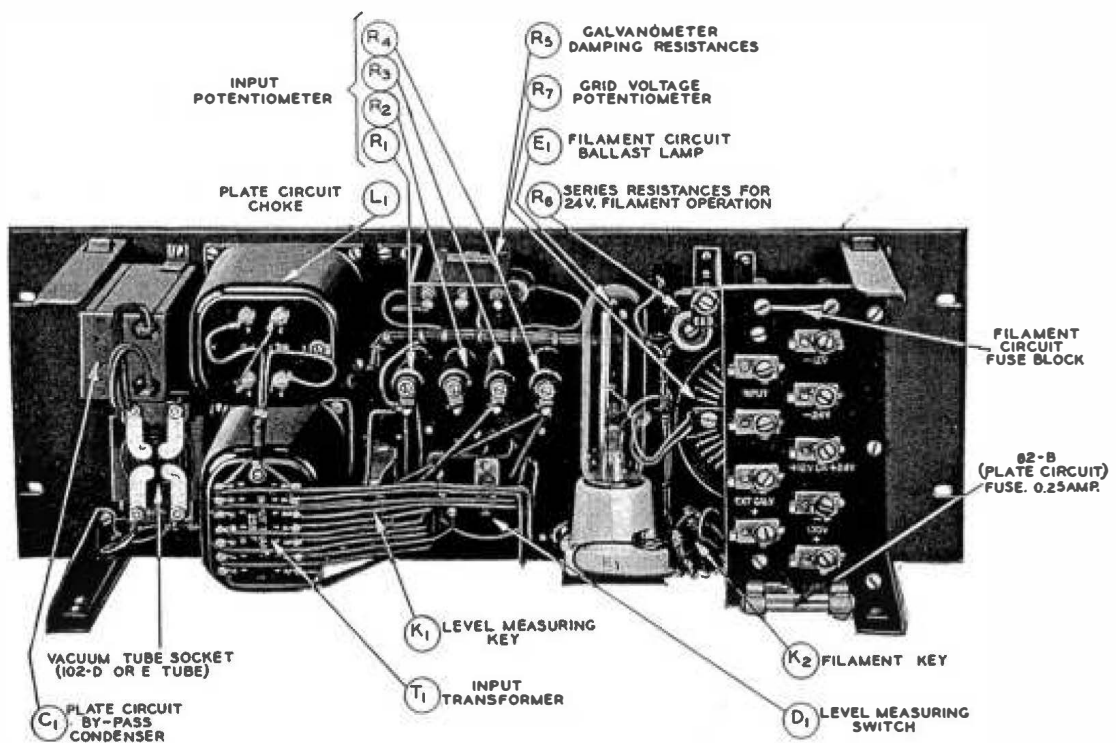

No. 203-B Panel—Rear View

supply 27 volts negative potential to the grid of the vacuum tube. The schematic of this amplifier is shown on pages 31 and 80, and the wiring diagram is shown on page 81.

No. 203-B Panel

The No. 203-B Panel* is fundamentally a peak voltmeter. It is so designed that when bridged across a 500-ohm line or across an amplifier output circuit which is terminated in 500 ohms, it gives an indication of the power level at the point where it is bridged. This panel gives readings in terms of a unit known as the "decibel" (abbreviated "db") which is used in telephone engineering to measure ratios of electrical power.**

For the benefit of those not familiar with the decibel the following description is included: Gain, loss and power level are measured in terms of a unit called the decibel. In the case of gain or loss the decibel is used to express the ratio of the powers at the output of the system due to a change in the circuit conditions such as the adjustment of potentiometer controls or the insertion or removal of amplifiers, transformers, etc.; or to give the ratio between the input power and the output power of a given device. When used in this sense it does not give any idea as to the amount of power involved but merely indicates the difference in power. The following table is printed to give the reader a quantitative idea of the relation which exists between decibels and power ratios.

<i>Decibels</i>	<i>Power Ratio</i>	<i>Decibels</i>	<i>Power Ratio</i>
1	1.26	10	10
2	1.6	20	100
3	2.0	30	1,000
4	2.5	40	10,000
5	3.2	50	100,000
6	4.0	60	1,000,000
7	5.0	70	10,000,000
8	6.3	80	100,000,000
9	8.0	90	1,000,000,000

By reference to an arbitrarily selected value known as the normal or zero level, the number of decibels above or below zero is used to indicate the actual power level. When used in this sense the number of decibels is not directly proportional to the electrical power involved (as it would be if the measurement were made in watts), but is roughly proportional to the sensation produced upon the ear when the electrical power is converted into sound by means of a telephone receiver. A difference of 1 db in the power supply to a telephone receiver represents approximately the smallest change in the volume of sound which the normal ear can detect.

* The No. 203-C Panel is supplied in later No. 8-B Speech Input Equipments. For this equipment the two panels are entirely interchangeable.

** The "decibel" was formerly called "transmission unit" (abbreviated TU) and early No. 203-B Panels used this designation.

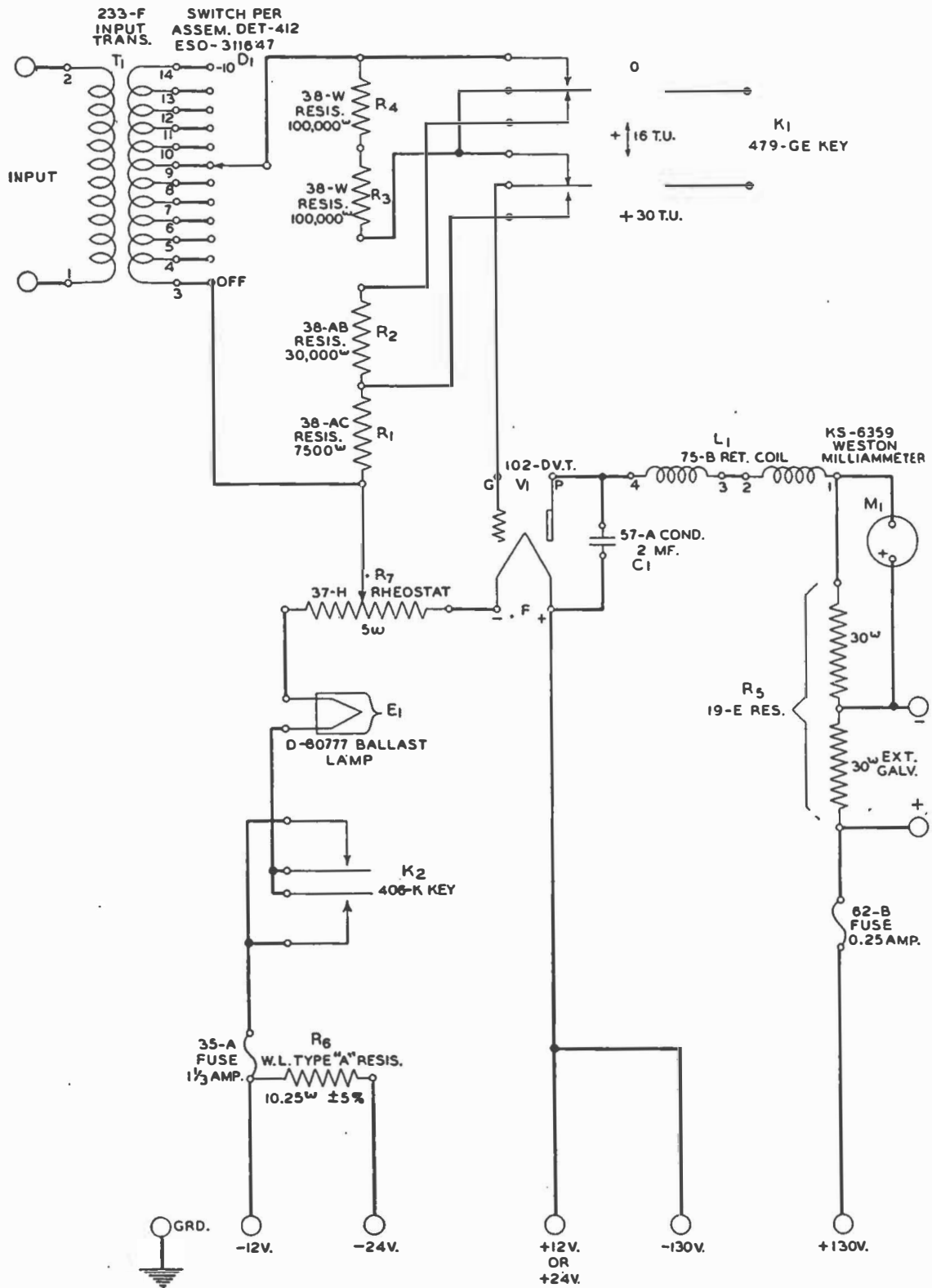

Schematic of No. 203-B Panel

The arbitrarily chosen value for the normal or zero level for this panel is 0.006 watts. The absolute values of power on this basis at various indicated levels are given in the following table.

<i>Decibels</i>	<i>Watts</i>	<i>Decibels</i>	<i>Watts</i>
—10	0.00060	+16	0.24
— 8	0.00095	+18	0.38
— 6	0.0015	+20	0.60
— 4	0.0024	+22	0.95
— 2	0.0038	+24	1.5
zero level	0.0060	+26	2.4
+ 2	0.0095	+28	3.8
+ 4	0.015	+30	6.0
+ 6	0.024	+32	9.5
+ 8	0.038	+34	15.0
+10	0.060	+36	24.0
+12	0.095	+38	38.0
+14	0.15	+40	60.0

The No. 203-B Panel, which is shown on page 32, uses one No. 102-D Vacuum Tube. The filament current of this vacuum tube is supplied through the 1-1/3-ampere fuse (No. 35-A Fuse) in position 2 on the No. 204-A Panel, mounted on the No. D-88823 Power Panel, and is regulated by the No. D-80777 Ballast Lamp mounted on the rear of the No. 203-B Panel. The plate potential for the vacuum tube is supplied from terminals "B" of the No. 1-B Rectifier through a potentiometer, comprising the resistances mounted in positions 4 and 8 of the No. D-86777 Mounting Plate on the No. D-88823 Power Panel, as mentioned in the description of the power panel. The No. KS-6359 Milliammeter mounted on the front of the No. 203-B Panel is the means by which the power level in the associated circuit is visually indicated. This is described in further detail in the section entitled "Operation". A schematic of this panel is shown on pages 34 and 82 and the wiring diagram is shown on page 83.

No. 514-A Panel

This panel, which is illustrated on page 36, is a meter panel, and is provided as a means of measuring the filament and plate currents of the amplifiers. It contains an ammeter and two milliammeters associated with two cords which are fitted with plugs for insertion into the current measuring jacks of the equipment. The ammeter reads currents up to four amperes, and the plug of the cord associated with this meter fits only the filament circuit jacks of the amplifiers. The two milliammeters associated with the other cord have ranges of 100 and 10 milliamperes respectively. Normally the high-range instrument is connected to the cord, but a push button is provided by means of which the low-range meter may be substituted when the current is too small to be read conveniently on the high-range meter. The plug of the cord associated with these meters is designed to fit the plate circuit jacks of the amplifiers, but is

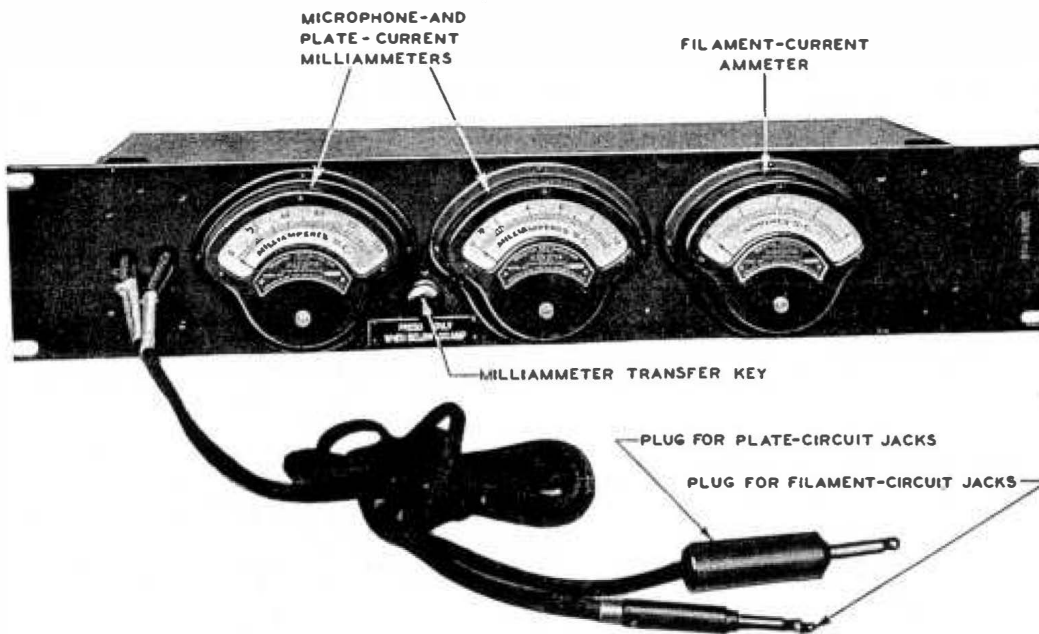

No. 514-A Panel—Front View

too large to be inserted in the filament circuit jacks of the amplifiers. This feature prevents possible damage to the milliammeters. The wiring diagram of the No. 514-A Panel is shown on pages 37 and 84.

No. 1-B Rectifier

This rectifier, illustrated on pages 38 and 39, is mounted on the No. D-88823 Power Panel. It is a single-phase, full wave vacuum tube rectifier which supplies direct current at 350 volts to the plate circuits of the amplifiers and to the voltage dividers which supply 130 volts to the plate circuit of the volume indicator and 200 volts to the condenser transmitters and associated amplifiers. This rectifier is designed to operate from an alternating current supply of either 110 or 220 volts, at any frequency between 50 and 133 cycles. It utilizes two No. 214-E Vacuum Tubes as rectifiers, transformers for supplying alternating current at the proper voltages to the filament and plate circuits of these vacuum tubes, and a filter for suppressing the alternating current components of the rectified output. Rheostats are incorporated to adjust the filament current of the vacuum tubes, and the alternating current voltage impressed on the rectifier circuit. Meters are also furnished for measuring filament current, the total direct current output and the output voltage of the rectifier.

A switch for starting and stopping the rectifier is so arranged that in the first position "FIL.", it completes the power supply to the filaments only of the vacuum tubes. In the second position "PLATE", it also energizes their plate circuits. The third position of the switch "OFF", disconnects the power supply from the rectifier. This rectifier is arranged for four output circuits, each controlled by a small snap switch. Associated with the "OFF" position of each

[37]

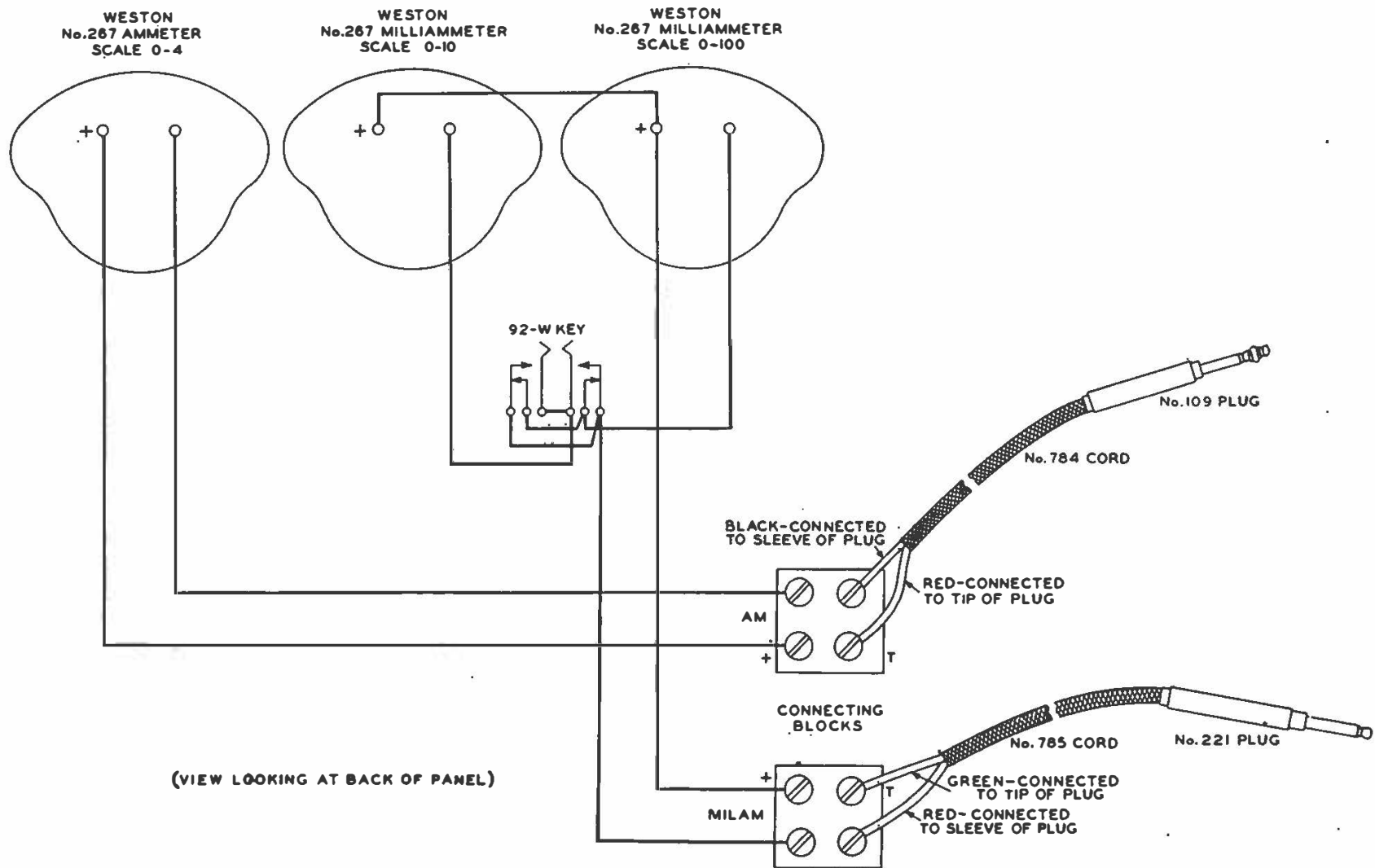

(VIEW LOOKING AT BACK OF PANEL)

Wiring Diagram of No. 514-A Panel

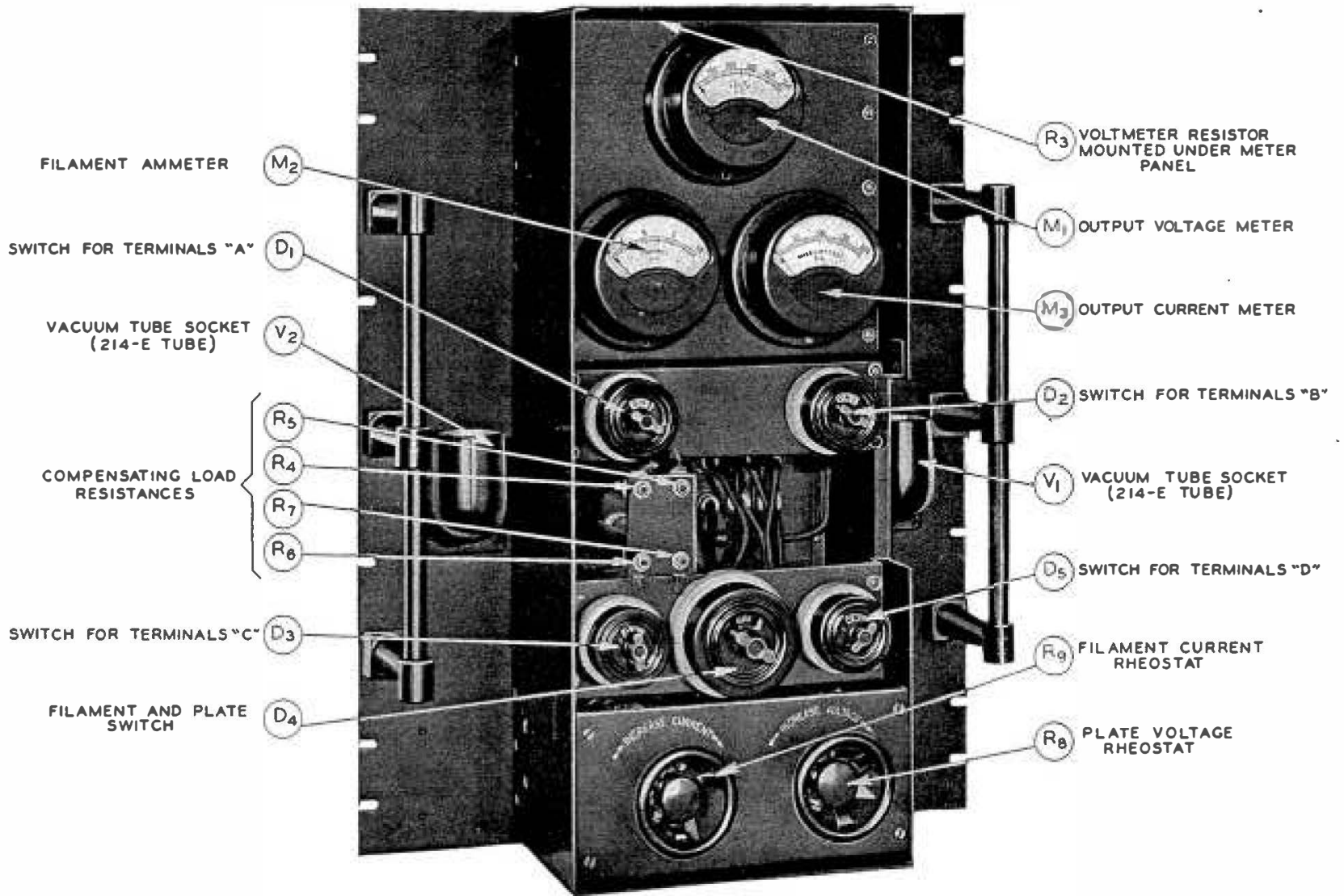

No. 1-B Rectifier—Front View

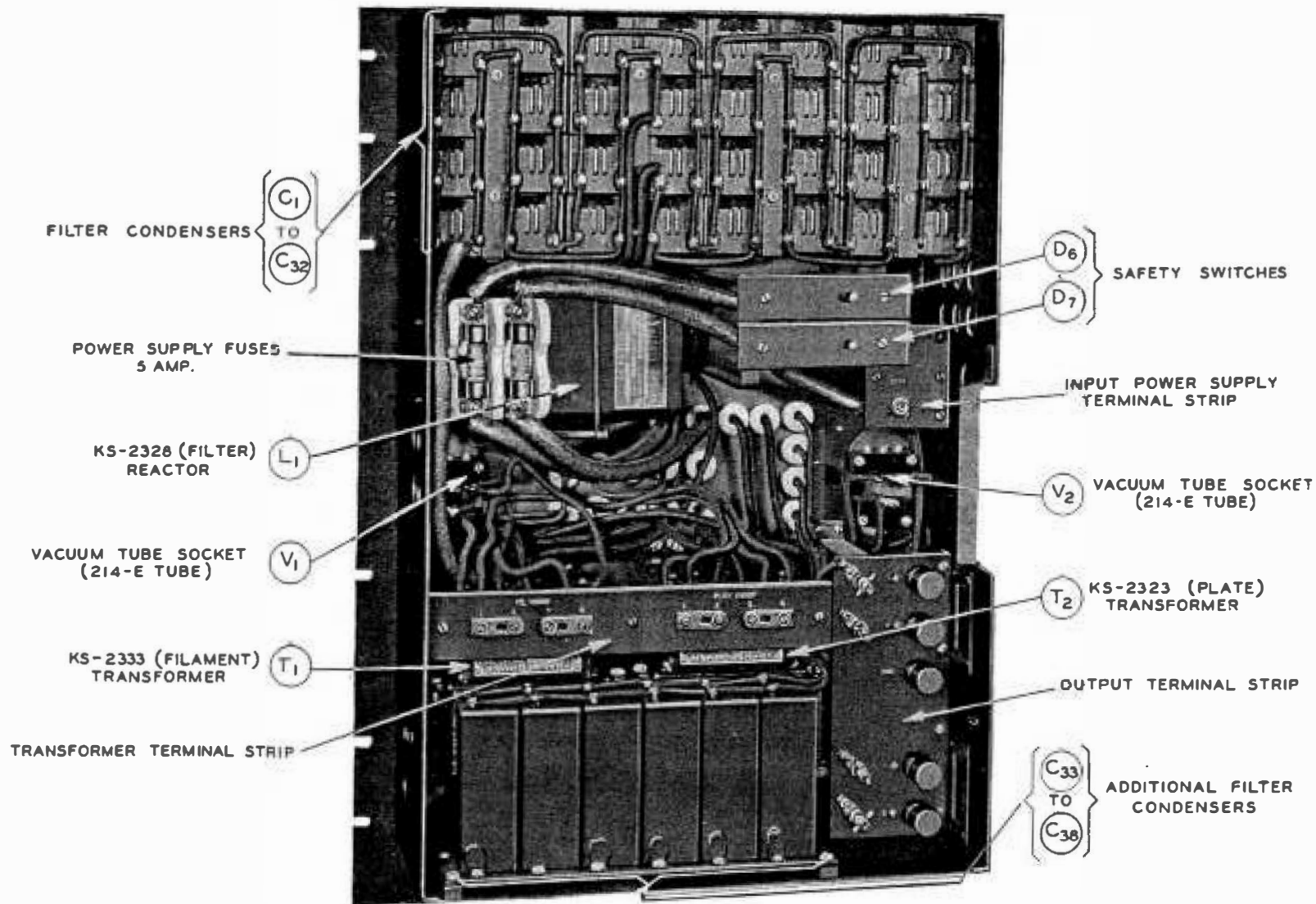

No. 1-B Rectifier—Rear View

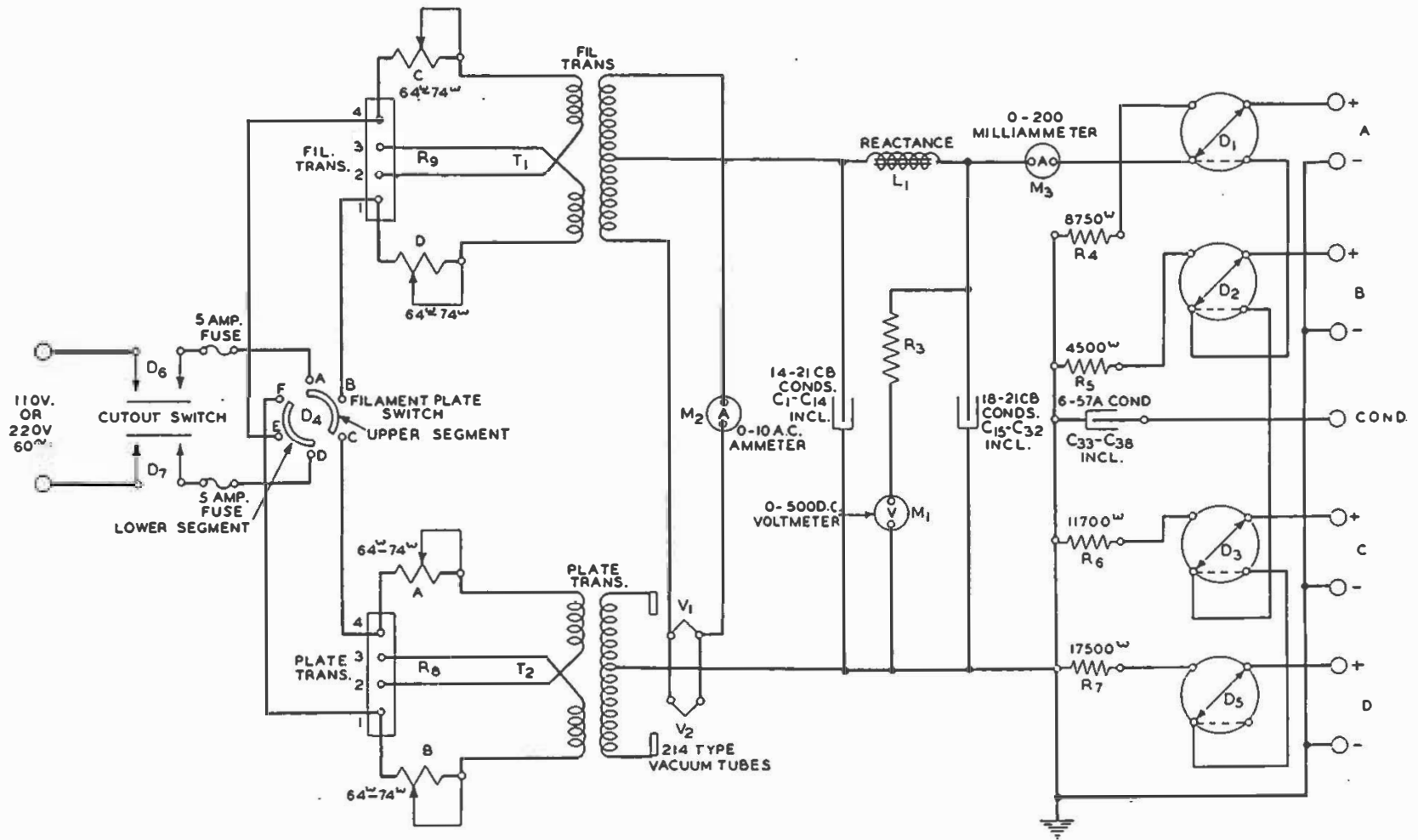

FIL. PLATE SWITCH
 POS. 1, FIL. A & B, D & E ARE CLOSED.
 POS. 2, PLATE A B & C, D E & F ARE CLOSED
 POS. 3, OFF A & B, D & E ARE OPEN.

4" RHEOSTATS "A & B" ARE OPERATED BY SAME HANDLE.
 4" RHEOSTATS "C & D" ARE OPERATED BY SAME HANDLE.
 ON 110V. CIRCUIT STRAP 1-2 & 3-4 ON EACH TRANS. TERM. BLOCK.
 ON 220V CIRCUIT STRAP 2-3 ONLY ON EACH TRANS. TERM. BLOCK.

Schematic of No. 1-B Rectifier

switch is a load resistance so that the load on the rectifier, and consequently its output voltage, will remain practically constant irrespective of the positions of the small switches. The back cover of the rectifier is provided with a safety switch so that the power supply to the rectifier is interrupted when this cover is removed.

When the rectifier power supply is 110 volts AC terminal 1 should be strapped to terminal 2 and terminal 3 to terminal 4 on both the filament and plate transformer terminal blocks. When the supply is 220 volts AC terminal 2 should be strapped to 3 on both terminal blocks.

The schematic of the No. 1-B Rectifier is shown on pages 40 and 86, and the wiring diagram on page 87.

No. D-86852 CONTROL CABINET

This control cabinet, illustrated below and on page 42, is to be located in the studio, and is a part of the studio control system. It consists of a No. D-86851 Signal and Control Unit mounted in a wooden cabinet which is so designed that the faces of the apparatus units contained in the signal and control unit are inclined at an angle of 45 degrees. The No. D-86851 Signal and Control Unit consists of an assembly of the apparatus units required to control, from the studio, the switching relays of the studio control system which are mounted on the No. D-87990 Miscellaneous Equipment Panel in the control room. The apparatus contained in the apparatus units is wired to a terminal strip at the rear of the signal and control unit.

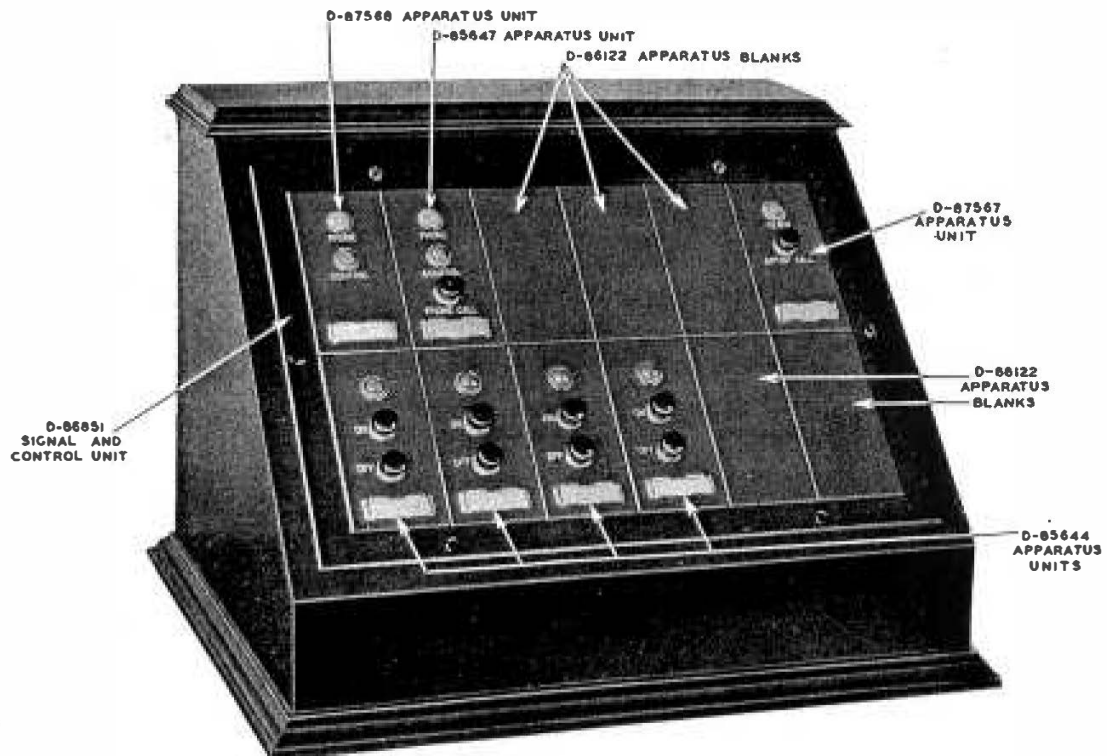

No. D-86852 Control Cabinet—Front View

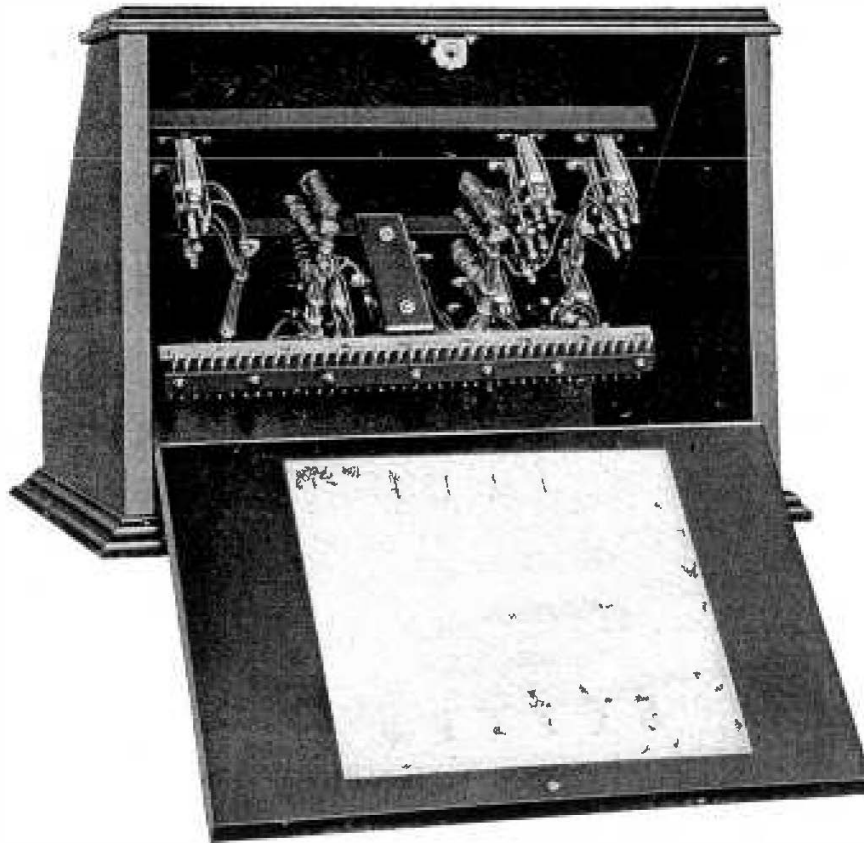

No. D-86852 Control Cabinet—Rear View

Position 1 of the signal and control unit is equipped with a No. D-87568 Apparatus Unit. This unit contains a red-capped lamp which, when lighted, indicates that the control on the No. D-85650 Panel in the control room is unlocked to make the switching relays subject to control from this control cabinet, and a white-capped lamp which, when lighted, indicates an incoming call on the interphone telephone system.

Position 2 is equipped with a No. D-85647 Apparatus Unit. This unit contains a push button for interphone signalling, and a white-capped lamp which lights when the button is pressed. It also contains a red-capped lamp which is lighted when the control is unlocked for the control room.

Positions 3 to 5 are normally equipped with No. D-86122 Apparatus Blanks but wiring is provided for No. D-85647 or No. D-85644 Apparatus Units in these positions.

A No. D-87567 Apparatus Unit is provided in position 6. This unit contains a green-capped lamp which is lighted when the circuit from the line amplifier to the telephone line to the radio transmitter is completed through the No. E-241 Relay, and a push button designated "ARTIST CALL". This button, when pressed, operates the No. E-241 Relay so as to disconnect the output of the line amplifier from the telephone line to the radio transmitter. By this means, it is possible to use the amplifiers of the equipment as a local public address system if desired.

Positions 7 to 10 are equipped with No. D-85644 Apparatus Units. The function of these units has already been described. Positions 11 and 12 are equipped with No. D-86122 Apparatus Blanks.

The units in this cabinet are normally arranged so that multiple control of the switching relays is provided both at this cabinet and at the No. D-85650 Panel mounted on the No. D-87990 Miscellaneous Equipment Panel in the control room. The No. D-86852 Control Cabinet wiring diagram is shown on page 85.

As previously noted, the descriptive matter and the schematics are presented on the assumed basis of one studio only. If more than one studio is equipped, additional No. D-86852 Control Cabinets will be used in the additional studios, and additional apparatus units will be required both in the No. D-86852 Control Cabinets and in the No. D-85650 Panel in the control room.

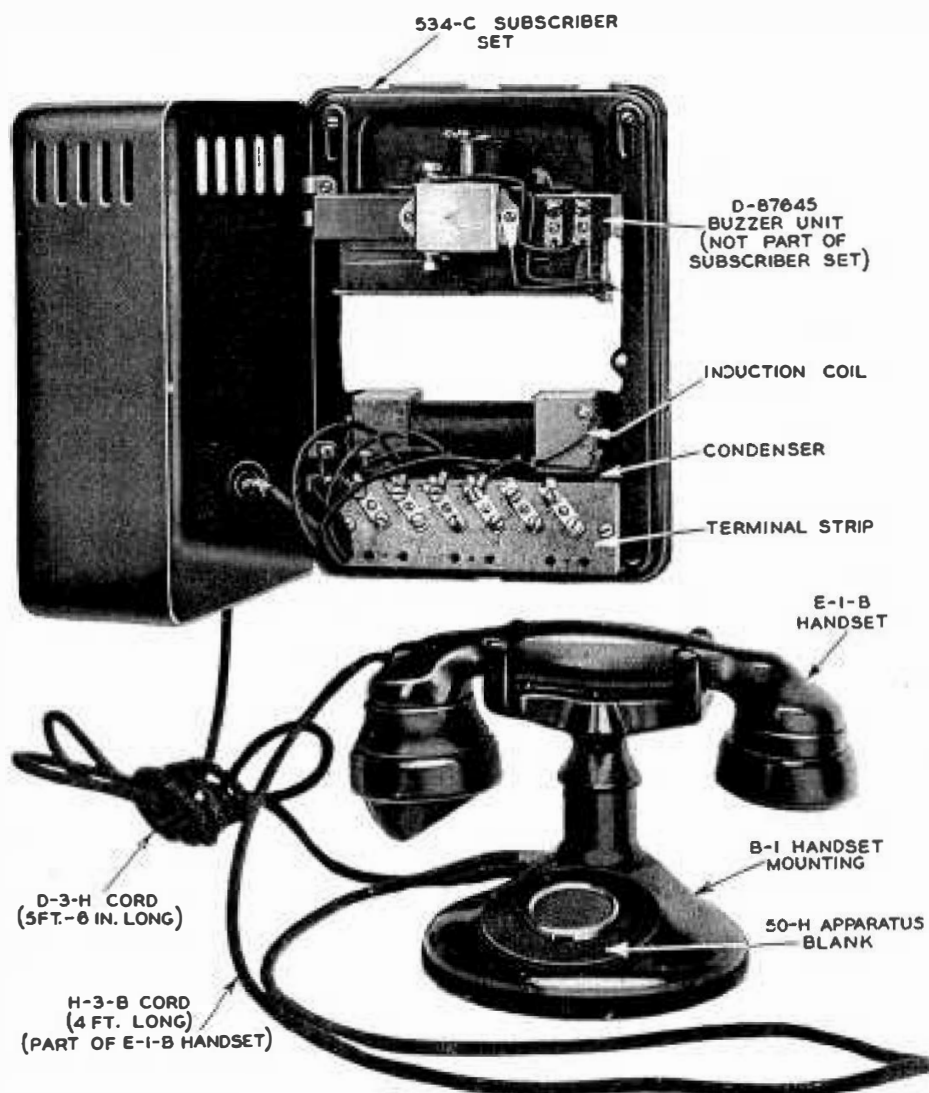

Interphone Telephone Set

ADJUSTMENT

STARTING

Power

After the apparatus has been installed the inter-wiring should be given a careful check to insure that the wires are connected to the proper terminals, and particularly in the case of both battery wiring and wiring from the power rectifier, that the leads are not interchanged. Then the following procedure should be followed in starting the equipment initially, and should also be followed whenever the equipment is started thereafter.

The safety switch associated with one of the storage batteries should be thrown to the discharge position. The condenser transmitter amplifier filament rheostats on the later models of the No. D-88823 Power Panel should be rotated in a counter-clockwise direction as far as they will go.

After this has been done the snap switch on the No. 204-A Panel (Battery Fuse Panel) should be operated to the "ON" position. The filament switches on the No. 8-C and No. 18-B Amplifiers and on the No. 203-B Panel should be operated to their "ON" positions and should remain so operated. The vacuum tube filaments of the apparatus on the amplifier panel should light. The filament currents of the various vacuum tube circuits should be measured by means of the ammeter on the No. 514-A Panel and the currents adjusted to the values given in the section entitled "Meter Indications."

Next the four small snap switches on the No. 1-B Rectifier should be operated to their "OFF" positions if they are not already in this position. The large snap switch on the No. 1-B Rectifier should then be operated to the "FIL." position by turning it once in the clockwise direction. The filaments of both rectifier tubes should light, and the filament current as indicated by the filament ammeter on the rectifier should be adjusted by means of the left-hand rheostat labeled "FIL." until the current is 6.5 amperes. After this has been done the large snap switch should be turned a second time in the clockwise direction to "PLATE". This operation should cause the voltmeter and the milliammeter on the rectifier to indicate. The right-hand rheostat marked "PLATE" should now be adjusted until the voltmeter reads 350 volts. After this has been done the upper left-hand small snap switch should be operated. This should not cause a change in the indicated current or voltage on the rectifier meters greater than ± 5 per cent.

After this switch has been operated the plate currents of the vacuum tubes in the No. 8-C Amplifier should be read by means of the milliammeters on the No. 514-A Panel. The upper right-hand small switch should now be operated and no greater percentage change in voltage or current should occur than before. The deflection of the meter on the No. 203-B Panel should be adjusted to the small red arrow which is the zero reference position on this meter by means of the "GRID BIAS" rheostat on this panel. When the No. 9-A Amplifier is added to this equipment the voltage for its plate circuit is also controlled by the upper right-hand switch on the rectifier.

The lower left-hand small snap switch on the No. 1-B Rectifier should now be operated. This should cause no greater percentage change in current or voltage than the operation of either of the other two switches and should energize the plate circuit of the No. 18-B Amplifier.

The lower right-hand snap switch on the rectifier should now be operated. This should cause no greater change in current or voltage than the operation of the other switches, and should complete the circuit for supplying the high voltage to the condenser transmitters and the associated condenser transmitter amplifiers.

After these four switches have been operated the filament current and output voltage of the rectifier should be readjusted to 6.5 amperes and 350 volts respectively if any such readjustment is necessary. When this has been done the milliammeter on the rectifier should indicate within the limits specified in the section entitled "Meter Indications".

Condenser Transmitters and Associated Equipment

After the high voltage supply has been connected to the condenser transmitters and their amplifiers, as described in the preceding section, any condenser transmitter and its amplifier may be put in operation by closing the amplifier filament circuit. Four keys mounted on the No. 367-A Key Mounting, on the No. D-87990 Miscellaneous Equipment Panel, are provided for turning the condenser transmitter amplifier filament circuits on and off. The key for the filament circuit of amplifier No. 1 is at the extreme left of the mounting, and the keys for the other amplifiers follow in numerical order. The "ON" position of any of these keys is indicated when the nickel plated knobs of the key are horizontal and the "OFF" position is indicated when they are vertical. In addition, a red-capped lamp immediately to the right of each key lights when the filament circuit of the associated amplifier is closed, to indicate that the amplifier is operating. Four rheostats, mounted on the power panel immediately above the No. 1-B Rectifier, are provided in the later No. D-88823 Power Panels as a means of adjusting the filament currents of the condenser transmitter amplifiers to the proper value.

It is advisable to turn on, when starting the equipment, as many condenser transmitter amplifiers as will be needed for the program to be broadcast, so that the click which will result from closing the amplifier filament circuit will not be heard during the program.

After the condenser transmitter amplifiers have been turned on their filament currents should be adjusted to the proper value by means of the rheostats on the power panel, if these rheostats are provided. Both the filament and plate currents of these amplifiers should be checked by means of the meters on the No. 514-A Panel, and should be within the limits specified under "Meter Indications". Jacks for this purpose are mounted on the miscellaneous equipment panel directly below the condenser transmitter amplifier filament keys.

When the adjustments outlined have been performed the condenser transmitters and their amplifiers are ready for operation.

Controls

In addition to the adjustments described in the preceding paragraphs, certain of the other controls need attention in starting the equipment.

The volume indicator level setting controlled by the key and the switch on the No. 203-B Panel should be adjusted to the level at which it is desired to supply power to the line to the radio transmitter. This adjustment together with the operation of the volume indicator is described in detail in the section entitled "Operation".

The "HIGH-LOW" switch on the No. 8-C Amplifier should be set initially in the "HIGH" position. The proper setting for the potentiometer gain control of this amplifier will then probably be found between points 6 and 16. If it is subsequently found that sufficient range of gain adjustment is obtained with the "HIGH-LOW" switch in the "LOW" position, it will be preferable to operate the amplifier with the switch in this position.

The "LOCK" keys in the No. D-85650 Panel should be operated to the "ON" position for the control room and for the studio from which the program is to be broadcast. When all is in readiness for broadcasting, the "READY" key on the No. D-85650 Panel should be operated to the "READY" position. The operation of this key will light the green-capped "READY" lamp in the studio control cabinet, as an indication to the studio force that broadcasting may proceed.

It should also be noted that the lighted green-capped lamps in the control room and in the studio are an indication that the output of the line amplifier is connected to the line to the radio transmitter; and if the latter is operating and is connected to the antenna, that any sounds near the condenser transmitters will be broadcast.

METER INDICATIONS

The filament current of each of the four condenser transmitter amplifiers, measured at the jacks designated "IA" on the No. 184 Jack Mounting on the Miscellaneous equipment panel, should be between 0.24 and 0.27 ampere or

TYPICAL METER READINGS

<i>Apparatus</i>	<i>Circuit</i>	<i>Reading</i>
*No. 203-B or C Panel	Plate	Red Arrow
No. 8-C Amplifier	Filament No. 1	0.95 Ampere
No. 8-C Amplifier	Filament Nos. 2 and 3	1.6 Amperes
No. 8-C Amplifier	Plate No. 1	0.5 to 1.0 Milliamperes
No. 8-C Amplifier	Plate No. 2	5 to 8 Milliamperes
No. 8-C Amplifier	Plate No. 3	15 to 28 Milliamperes
No. 18-B Amplifier	Filament	1.6 Amperes
No. 18-B Amplifier	Plate	15 to 28 Milliamperes
No. 1-B Rectifier	Filament	6.5 Amperes
No. 1-B Rectifier	Output Voltage	350 Volts
No. 1-B Rectifier	Output Current	159 to 181 Milliamperes

* An indication of this current is read on the meter mounted on the No. 203-B Panel and is adjusted by means of the potentiometer designated "GRID BIAS" on this panel. This adjustment must be made with the dial switch on this panel in the "OFF" position.

should be adjusted to 0.27 ampere if the filament rheostats are available. The plate current of each amplifier, measured at the "IB" jacks on the same mounting, should be approximately 0.7 milliampere. The current and voltage readings for the other apparatus should be within the limits given in the accompanying table.

STOPPING

In discontinuing the use of the speech input equipment the large snap switch on the No. 1-B Rectifier should first be operated in a clockwise direction to the "OFF" position. Next, the snap switch on the No. 204-A Panel should be operated to the "OFF" position. Finally, the small switches on the rectifier may be operated to their "OFF" positions.

OPERATION

CONDENSER TRANSMITTERS

After the condenser transmitter and its associated amplifier have been assembled in the transmitter mounting with a No. T2E Cord connecting the transmitter and amplifier and a No. M6B Cord terminated in a No. 253-A Plug connected to the amplifier, this equipment may be considered as a unit for the purpose of picking up program material. The No. 253-A Plug may be connected to either a No. 369 or No. 370 Jack in the studio or in the control room, thus connecting the condenser transmitter assembly to the control circuits on the miscellaneous equipment panel. After the power supply to the condenser transmitter amplifier is turned on and the associated switching relays are operated the condenser transmitter is ready for use.

The desk type transmitter mounting may be placed on a table or desk in any convenient location, and is especially suitable for announcing. The floor type transmitter mounting is adjustable so that the condenser transmitter may be placed at any height between 4 feet 6 inches and 6 feet from the floor. To adjust the height it is merely necessary to slide the upper part of the tube holding the transmitter housing up or down. The friction between the lower and upper parts of the mounting is sufficient to hold the transmitter in position without the need of a locking device. In adjusting this mounting, care should be taken not to rotate the upper part, nor raise and lower it unnecessarily, as the No. T2E Cord which connects the upper and lower parts may be damaged by careless handling.

The No. 394 Transmitter is a delicate and precisely adjusted piece of apparatus, and must be handled with considerable care. It is shipped in a sealed tin box as shown on page 20 and it is suggested, when the transmitter is not to be used for some time, that it be kept in this box to avoid danger of its being damaged. Before it is placed in the box it is well to warm both the transmitter and the box slightly in order to eliminate any moisture. The diaphragm which is behind the heavy mesh screen must not be touched or tampered with because even a slight pressure may rupture the diaphragm or short-circuit the instrument.

Sudden changes in temperature, such as are encountered in carrying the condenser transmitter out of doors from a warm room on a cold day may adversely affect the instrument. It should not be placed in operation until all of its parts have attained the same temperature. It will not operate at extremely low temperatures, 20 degrees F. being about the lowest temperature at which it will operate satisfactorily.

STUDIO CONTROL SYSTEM

Ordinarily the operating procedure for the studio control system will be for the control room operator to unlock the control for the No. D-85650 Panel on the No. D-87990 Miscellaneous Equipment Panel and for the No. D-86852 Control Cabinet at the location where the studio program is originating. After

this has been done, the studio announcer should be allowed to have complete control of the operation of the system by means of the "ON" and "OFF" keys of the No. D-85644 Apparatus Units in the No. D-86852 Control Cabinet unless an operation of the equipment occurs which is obviously an error on the part of the announcer. In this case, it is desirable for the control room operator at the No. D-87990 Miscellaneous Equipment Panel to disconnect the circuit which has been erroneously connected. In addition this operator may make the correct connection, if this operating routine has been adopted. The switching relays for the outside line circuits are subject to control only from the No. D-85650 Panel in the control room, because before using these circuits the control room operator must perform the necessary patching operations at the No. D-87990 Miscellaneous Equipment Panel.

In case it is desired to disconnect the studio from the line to the radio transmitter for any reason, the control room operator should operate the "READY" key in the No. D-85650 Panel to the "OFF" position. In this connection it should be noted that the "ARTIST CALL" key in the No. D-86852 Cabinet will accomplish this same result if held operated. For this same reason, it is undesirable to use the "ARTIST CALL" feature of the studio control system unless it is imperative to do so as its operation causes a break in the continuity of the program.

Even though the buzzers which are a part of the interphone signalling system are disconnected when a microphone is connected at any point of origin of a program, it is undesirable to try to communicate with any one in a studio or other location while a microphone at that location is connected to the amplifier input circuit. This procedure, in addition to distracting the attention of the announcer or operator at that point, has a further disadvantage in that any attempt at telephone conversation will be highly unsatisfactory. This is true because it is necessary for the announcer to keep definitely in mind the extreme sensitivity of the condenser transmitters and to speak accordingly, as otherwise undesirable background noise will be transmitted with the program.

OUTSIDE LINE CIRCUITS

The outside program line circuits are so arranged that any two program lines may be patched at the miscellaneous equipment panel by the use of patching cords (No. P2AA Cords with a No. 241-A Plug at each end) through the two switching relay circuits and the two 20-decibel artificial lines provided for them to the input side of two of the mixing potentiometers. The two potentiometers will be automatically disconnected from their respective condenser transmitter circuits by the patching operation. When this has been done, the two outside program circuits thus chosen may be switched in or out by means of the push buttons of the No. D-85644 Apparatus Units on the No. D-85650 Panel in the control room. Auxiliary contacts on the output jacks for the two outside line switching relay circuits make these circuits inoperative until their outputs are patched to the inputs of the mixing potentiometers. The 20-db artificial lines are provided for use between the outside program lines and the switching

relay circuits in order to reduce the outside program material to a suitable level before it is applied to the input of the No. 8-C Amplifier and also to effect a suitable match between the high impedance of the lines and the low impedance of the mixing potentiometers.

In an emergency it may be necessary to interchange the program and order wire lines from one point, and this can be done by the use of two patching cords (No. P2AA Cords with a No. 241-A Plug at each end) plugged into the appropriate jacks on the miscellaneous equipment panel. The method of performing this operation, as well as the patching incident to normal use of the outside line facilities, can readily be seen by reference to the schematic of outside line control circuits on pages 10 and 73.

If it is desired to listen to a program or to other material sent over the program line from the outside pickup point before the line is actually connected, by patching, to the speech input amplifiers, this may be done by the use of a telephone receiver (such as a Western Electric No. 1002-Type Headset) connected to a No. 241-A (or similar) Plug which may be inserted in the appropriate jacks.

An incoming call on any of the order wires may be answered by patching between the associated order wire jacks on the miscellaneous equipment panel and the order wire telephone set jacks also on that panel. This is done by means of one of the patching cords. To initiate an outgoing call on an order wire, it is necessary to patch in the same manner between the order wire jacks and the ringing current supply jacks. After ringing the remote point in this manner, the plug of the patching cord may be withdrawn from the ringing current supply jacks and inserted in the order wire telephone set jacks.

In connection with the above description it may be helpful to refer to the diagram of jack strip designations on page 14, which shows the jacks with their designations as they appear on the miscellaneous equipment panel.

VOLUME INDICATOR

After the volume indicator plate current has been adjusted as outlined in the table of meter indications, the level measuring switch and key should be set at the level at which the program currents are to be applied to the associated radio transmitter, when the studio and the radio transmitter are at the same location, or the level at which the program currents are to be applied to the telephone line to the radio transmitter when the studio and the radio transmitter are at widely separate points.

In the case of the remotely located radio transmitter, the level at which the program material is delivered to the telephone line will be governed largely by the operating conditions outlined by the local telephone company supplying the telephone line service. Generally, an input level to the line to the transmitter of +2 db will be satisfactory. Special conditions may, however, modify the energy level at which the program material is impressed on the line.

When the radio transmitter and the studio are at the same location, the level at which the program material is delivered to the radio transmitter depends upon the input level for which the radio transmitter is designed. Usually this will be between -10 db and -4 db.

The correct setting for the level indicating key and switch is accomplished as follows: The energy level is obtained by adding algebraically the setting of the key which may be "0", "+16 db" or "+30 db", to that of the dial switch which may be any value between -10 and $+10$ db in steps of 2 db. For example, if the setting of the key is +16 and the reading of the dial switch -4 , the energy level measurements would be $+16 - 4$ or $+12$ db when the galvanometer deflections are within the specified limits.

The volume indicator is the best guide to the proper adjustment of the volume level at the input to the line to the radio transmitter. When the galvanometer needle swings to 30 divisions about once every 10 seconds during the transmission of speech, the volume level at the point in the circuit at which the volume indicator is connected is the algebraic sum of the key and switch settings. During broadcasting the volume indicator meter needle will follow the fluctuations of the program currents and for the louder tones should reach a deflection of 30 divisions but should rarely go above 30. Smaller deflections may be disregarded.

It should be noted that the potentiometer gain control of the No. 8-C Amplifier controls the gain or amplification on all program channels simultaneously, while the gain adjustment on individual channels is accomplished by the mixing potentiometers.

In general, the adjustment of the amplifier controls of the equipment should not be changed during any one program number. It may be necessary to deviate from this practice and make slight adjustments during musical numbers in which unusually loud or faint passages are rendered. However, any change in the amplification during a musical number is undesirable because it impairs the expression of the artist.

MONITORING

It is possible to monitor the program at the input to the wire line to the radio transmitter by operating the monitor transfer key located on the No. D-85650 Panel of the No. D-87990 Miscellaneous Equipment Panel to the "INPUT" position. This operation connects the input of the No. 18-B Amplifier across the output of the No. 8-C Amplifier. This can be seen by reference to the schematic of the amplification and gain control circuits on page 12.

If a supplementary radio receiver such as the No. 6604-D Radio Receiving Outfit is located at the studio point, or if the output of the monitoring rectifier which is part of the radio transmitter is available at the studio location, it will be possible to monitor the output of the radio transmitter through the radio receiver or monitoring rectifier. This can be done by connecting the audio fre-

quency output of the receiver or rectifier to the side of the monitor transfer key designated "OUTPUT" and operating this key to that position.

Normally it is preferable to monitor at the output of the radio transmitter if possible as this gives the operator a definite idea of the quality of the program material as it is actually being transmitted. Also it is possible, by operating the transfer key and listening to the loud speaker connected to the No. 18-B Amplifier output with the key in each position, to make a comparison of the quality both at the output of the No. 8-C Amplifier and at the output of the radio transmitter through the radio receiver or monitoring rectifier. When making this comparison, it is very important that the volume of sound output from the loud speaking telephone be the same in both instances. Before making any comparisons, therefore, the output of the radio receiver or monitoring rectifier should be so adjusted that the volume is the same when the key is thrown to the "OUTPUT" position as when it is thrown to the "INPUT" position.

It may also be pointed out that quality cannot be judged satisfactorily when reverberation is present. Monitoring is necessarily done in the control room and better results may be expected if this room is treated acoustically.

BATTERY CHARGING

The chart on page 19 shows the typical charging cycles for the two storage batteries if the period of operation is eighteen consecutive hours out of every 24-hour period. It should be noted that normally eighteen hours are always available in which to recharge the battery which has been carrying the load for twelve hours. It should be a part of the station routine always to charge the battery which has been in use during the available eighteen-hour period, as by following this routine the batteries will always be in satisfactory condition to operate the equipment. In connection with the charging of the batteries the instructions given in the manufacturer's booklet should be followed and particular care should be exercised not to exceed the maximum charging rate recommended as this somewhat shortens the life of the batteries.

MAINTENANCE

GENERAL

For best operation, this equipment must be kept free from dust and dirt. High pressure air is recommended for cleaning the apparatus on the panel assemblies but a soft bristled brush may be used with good results. Lemon oil may be used to polish the panels and dust covers of the apparatus on the panel assemblies. It should be used sparingly and wiped off with a soft cloth.

All electrical connections should be examined periodically and any loose contacts repaired. In addition, the contacts of the keys and jacks should be inspected periodically and cared for as outlined below. Trouble can often be prevented by these precautions.

VACUUM TUBES

Whenever possible tube failures should be anticipated and replacements made before actual failures occur. Tube failures may be guarded against to some extent by keeping a record of the length of time each tube has been in service and by observing the condition of the elements inside of the tube. The plate or grid may warp or the filament may sag or one spot in the filament may begin to glow brighter than the rest of the filament when it is lighted. If any of the above mentioned effects is observed the tube should be replaced as otherwise there is danger of a tube failure during operation and a resulting interruption in the broadcast program.

Tubes should never be operated at higher filament currents or plate potentials than those specified as such operation shortens the life of the tubes and does not improve the operation of the equipment.

BATTERIES

Storage Batteries

Test the storage batteries regularly to determine whether or not they need recharging.

Follow the manufacturer's instructions which are furnished with the batteries for their installation, operation and maintenance.

In addition it should be especially noted that longer and more satisfactory service will be obtained from the storage batteries if the following precautions are followed:

1. Keep the outside of the battery clean and dry.
2. Keep the separators covered with electrolyte at all times.
3. Except in an emergency stop discharge before the voltage becomes too low for satisfactory service. The drop in specific gravity should not be greater than 40 points compared to its value when the battery is fully charged.
4. Always charge at rates low enough to keep the cell temperature below 100 degrees F. and while the cells are gassing, never charge at higher than a

15-ampere rate. (In this connection it should be noted that the ampere hour charge will generally approximate the ampere-hour discharge plus approximately 10 percent to return the battery to the condition of charge which it had initially.)

5. Ventilate the battery cabinet freely when charging and never bring a lighted match or other exposed flame near the battery.

6. Never add electrolyte or acid except under the conditions explained in the manufacturer's instruction book. Never allow metals or other impurities of any kind to get into the cells.

7. Ammonia or bicarbonate of soda solutions will neutralize the effects of spilled acid if applied immediately.

Dry Batteries

Check the voltage of the grid batteries in the speech input amplifiers at regular intervals. Ordinarily measurement of the voltage of each of these grid batteries once every two weeks should be sufficient. If the voltage of these batteries falls below 24 volts in the No. 8-C Amplifier and in the No. 18-B Amplifier, the battery should be replaced. To replace the grid batteries remove the new No. 703 Eveready batteries from the rectangular pasteboard cases in which they are packed. Polish the brass springs with fine sandpaper (size No. 0 or No. 00) and carefully bend the short springs forward as sharply as possible over the wax tops of the batteries. After bending make sure that there is a space of at least $\frac{1}{4}$ inch between the ends of the springs. If this amount of clearance is lacking, cut off the longer springs until $\frac{1}{4}$ inch clearance is obtained. Insert the batteries in the box, spring ends first, so that the short springs strike the top contacts in the back of the box. Close the covers with a steady pressure on the lids and fasten the catches. After the batteries are inserted, their voltage should be checked.

RELAYS

The chief maintenance requirement for the relays of this equipment is to keep dirt and other foreign substances out of the contacts and moving parts. Foreign matter wedged between contact springs or between an armature and a pole-piece may prevent springs from making contact. As a matter of routine, all relays should be cleaned at such intervals as operating experience indicates to be necessary.

When cleaning relays, first brush off the dust from the exposed parts of the uncovered relay. If necessary, clean the non-contact bearing parts which, if dirty, may prevent the proper operation of the relay. This is done by passing a linen tape described in the list of maintenance equipment, back and forth between the armature and the adjusting nut and around the adjusting stud, thereby removing whatever dirt may be on the back of the armature, the adjusting nut and the stud. The linen tape should never be used on contacts

as the sharp edges of the contact points may tear the tape with the result that particles of linen will be left on the contacts.

Clean the contacts with the highest purity carbon tetrachloride in the following manner:

Dip the flat end of a clean toothpick in the carbon tetrachloride to the depth of about $\frac{1}{4}$ inch and deposit the liquid on the contacts (held slightly separated), then rub the flat end of the toothpick back and forth two or three times between the contacts, which should now have slight pressure against the sides of the toothpick. The liquid will soften any deposit that may have collected on the contacts and the rubbing will remove it. Next, with the contacts held slightly apart, they should be flushed with a little liquid taken on the clean point of the toothpick (not the end that was used for rubbing). Be sure that the sides as well as the top of the contact points and discs are flushed, as dirt on the sides is loosened when the liquid is applied to the contacts and if this dirt is not cleaned off, it may later be deposited on the contact surfaces. The flushing is intended to wash off any particles that remain after the rubbing. The toothpick should be discarded after cleaning a single pair of contacts and a new, clean toothpick used for cleaning the next pair of contacts.

It is important that this method of using carbon tetrachloride be strictly adhered to and that a clean toothpick be used for each set of contacts as it has been found that, otherwise, the deposit removed from one set of contacts may be left in the liquid and later deposited on another set of contacts.

Care should be taken to keep the carbon tetrachloride from coming in contact with rubber studs or insulators as far as practicable, as carbon tetrachloride has an injurious effect on rubber if applied frequently.

The bottle containing the carbon tetrachloride should be kept corked when not in use to prevent evaporation and to prevent dust settling in the liquid. The liquid and the inside of the bottle must not be permitted to become dirty. Cleaning of the bottle and replacing of the liquid will prevent this.

On relays where the separation or the location of the contacts is such that it is not practicable to insert the toothpick, it will be satisfactory to clean with a burnisher only.

CAUTION:

THE ADJUSTMENT OF THE RELAYS SHOULD NOT BE DISTURBED IN ORDER TO CLEAN THEIR CONTACTS.

Following the use of the carbon tetrachloride the contacts should be burnished with a No. 265 (Burnishing) Tool. In burnishing normally open contacts it will be necessary to push the contacts together manually, giving a slight pressure only on the blade of the burnisher. In the case of normally closed contacts the tension of the springs themselves will furnish sufficient pressure against the burnisher. Usually by rubbing the burnisher back and forth between the contacts two or three times, the desired result is obtained.

Pitted contacts should be treated by inserting the burnishing blade between the contacts and rubbing it back and forth until the pits, if not removed, are reduced appreciably.

Before replacing relay covers be sure that they have been cleaned on the inside. Do not use a cloth which has been moistened with oil of any kind.

In using relay spring adjusting tools (No. 50 or No. 259) the slot in the end of the tool should be slipped over the spring near its front end and then moved back to a point about $\frac{1}{4}$ inch to $\frac{1}{2}$ inch from the heel of the spring. In this position, a slight turn one way or the other will increase or decrease the spring tension. Excessive turning of the tool should be avoided, since such practice is apt to disturb the tension, to loosen springs or, when the spring is adjacent to the armature, to bend the armature hinge out of place.

CAUTION:

UNLESS IT IS CERTAIN THAT THE RELAYS ARE OUT OF ADJUSTMENT, THEIR ADJUSTMENT SHOULD NOT BE CHANGED.

JACKS, KEYS AND LAMPS

As is the case with relays, the chief maintenance required for jacks and keys is to keep dirt and other foreign substances out of the contacts. The contacts of the keys and jacks of the equipment may be cleaned in the same way as those of the relays, and should be burnished as a matter of routine using the No. 373 handle and the Nos. 374-A and 374-B Burnishing Tools.

When burnishing the normal contacts of the jacks of the equipment the No. 374-A Tool should be inserted in the handle (No. 373 Tool) so that only about $2\frac{1}{8}$ inches protrudes. This will prevent the blade from coming in contact with the insulation in the spring pileup, thus avoiding damage to any portion of the insulation. Insert the blade carefully in the jack until it just meets the normal contact. Then with a slow turning movement, the tool will tend to lift the normal spring from the normal contact, and by a slight forward pressure, it will be found that the blade slips easily between the contacts. A few strokes of the burnisher should be sufficient to clean the normal contact. If trouble still exists after this burnishing process, the jack should be inspected for poorly adjusted springs or bad contact points.

Beyond the occasional replacement of a burned-out No. 2-F Lamp, the indicating lamps of the system require no special maintenance. A No. 319-B Tool may be used for removing lamp caps, and a No. 116 Tool for removing the switchboard lamps from the sockets.

CORDS AND PLUGS

After a certain amount of use, it is possible that trouble may be experienced due to the breaking of strands and conductors in the flexible cords. This may occur in the cords used in connection with the condenser transmitters and

their amplifiers, the No. P2AA Cords used for switching and testing in conjunction with the jacks of the miscellaneous equipment panel and the ammeter and milliammeter cords of the No. 514-A Panel. Ordinarily, it will be more satisfactory to discard such cords than to attempt to repair them.

As a matter of routine maintenance the No. 241-A Plugs on the No. P2AA Cords and the plugs on the cords of the No. 514-A Panel should be polished with fine sandpaper to remove any film of grease and oxide which may have accumulated. This procedure will reduce to a minimum troubles caused by dirt on the plugs.

POTENTIOMETERS AND RHEOSTATS

Insofar as possible, dust and dirt should be kept away from the potentiometers and rheostats of the equipment. In addition, the shaft bearings of the rheostats and potentiometers should be lubricated occasionally with ordinary vaseline. This should be used very sparingly and any excess which is applied to the bearings should be rubbed off with a clean, soft rag.

It may be necessary occasionally to clean the contact points of the No. D-90433 potentiometers. This should be done with a clean, soft rag. After the contact points have been cleaned in this manner they should be lubricated with a thin film of vaseline. The excess vaseline should be carefully removed with another clean, soft rag. Great care should be taken not to disturb the coils of fine resistance wire which are fastened around the periphery of this type potentiometer, as the fine wire is easily broken.

When No. D-85074 (No. 33-A) Potentiometers are used their resistance discs should be cleaned, when necessary, with a piece of clean linen tape, a piece of special lintless cloth per No. KS-2423 or, in extreme cases, with a soft, gritless rubber eraser. Care should be taken not to break or mar the fine wire used to wind the resistance discs nor to disturb the tension and adjustment of the contact arms of the No. D-85074 (No. 33-A) Potentiometers. In addition, it is important that the small contact rollers turn freely in their bearings, so as not to roughen or wear through the fine wire on the resistance discs.

CAUTION :

CARBON TETRACHLORIDE SHOULD NEVER BE USED ON EITHER
TYPE POTENTIOMETER.

MAINTENANCE EQUIPMENT

The following equipment will be useful in maintaining the apparatus of the equipment:

An electric soldering iron for removing soldered connections or making temporary connections while testing, and for repairing loose and broken contacts.

Rosin core wire solder for use in repairing connections.

Fine sandpaper (No. 0 or No. 00) for cleaning plugs and large contacts.

A small screwdriver with a fine blade for tightening miscellaneous small screws of the equipment.

A pair of long nose pliers for use in connection with the maintenance of wiring.

A pair of diagonal cutting pliers for cutting wires when necessary.

Chemically pure carbon tetrachloride for cleaning contacts.

Clean toothpicks made of hard wood, flat at one end and pointed at the other.

A brush suitable for dusting off relay parts and cleaning the inside of relay covers.

Linen tape $\frac{1}{4}$ inch wide and 0.005 inch thick, Western Electric catalogue list No. 10470.

No. 116 Tool for removing switchboard lamps.

No. 319-B Tool for removing lamp caps.

No. 265-B Tool for burnishing relay contacts.

Nos. 373, 374-A and 374-B Tools for burnishing key and jack contacts.

No. KS-6015 Tool for adjusting springs, particularly on lever unit keys.

No. KS-2348 Tool for removing and replacing the screws in plugs and plug shells.

Nos. 50 and 259 Tools for adjusting the springs of "E" and "R" type relays.

LOCATION OF TROUBLES

GENERAL

If routine maintenance tests are made regularly and carefully very few cases of trouble will occur. However, when trouble does arise, an experienced operating personnel is a valuable asset. To the new operator simple troubles are often baffling, while to the experienced operator the cause is obvious. These suggestions on the location of troubles are written primarily for the person who operates the equipment for the first time. As operating experience accumulates the operator will become better fitted to recognize the cause of the trouble from the symptom.

It is not possible to anticipate every case of trouble that may arise and to provide a plan for its location. It is our purpose, however, to make certain suggestions which will be of use in a large majority of cases and to give a few examples of the application of these methods to those cases of trouble that are bound to arise in spite of the most thorough maintenance.

If trouble develops the adjustments of all circuits should first be carefully checked. If this check shows that any circuit is not operating properly, the circuit should be isolated and a thorough inspection of the individual unit made. It is generally possible to isolate the trouble immediately, but if the cause is not easily located, a more careful test of all circuits should be made, in which case it is of the utmost importance that the tests be made systematically.

Do not use a buzzer for testing the continuity of amplifier circuits because of the danger of magnetizing the cores of some of the coils and thus impairing the frequency characteristic of the amplifier. A high resistance telephone in series with a flashlight battery should be used for this purpose. Care should be taken, however, to distinguish between the click in the telephone when the contact is first made (due to capacity effect) and the click due to the passage of current as the circuit opens and closes. The former usually occurs only on the first making of the contact, and subsequent contacts result in weaker clicks.

An electric soldering iron will be found convenient for removing soldered connections or making temporary connections while testing. Only rosin core solder should be used. Acid and paste fluxes have an injurious effect on insulation.

BATTERY SUPPLY

If the batteries themselves are maintained in a satisfactory condition for operation, little trouble should be experienced with them. The following will be of help in locating trouble which may be experienced in the battery circuits. There are two locations at which the discharge circuits from the batteries are fused. The first is the fuse cut-out which is located near the batteries. At this point both the positive and the negative leads are fused. Secondly, the negative (ungrounded side) of each individual circuit is fused at the No. 204-A Panel mounted on the No. D-88823 Power Panel. Fuses on this panel are of

the indicating type and, in addition, the blowing of one of these fuses causes the red-capped indicating lamp in position 16 of the No. 367-A Key Mounting of the No. D-87990 Miscellaneous Equipment Panel to light.

If none of the filaments light when the switch on the No. 204-A Panel is operated to the "ON" position, the first fuses referred to should be inspected. If some of the filament circuits are energized and others are not, this may be due either to a blown fuse on the No. 204-A Panel as described previously or to the accidental operation to the "OFF" position of the filament circuit switch on the apparatus on which the vacuum tubes do not light.

PLATE SUPPLY

The plate circuits of all the vacuum tubes obtain power from the No. 1-B Rectifier located on the power panel. This rectifier has a voltmeter to indicate the output voltage and a milliammeter to indicate the total output current. The indications given by these two meters should be within the limits outlined above under "Meter Indications" when all of the small snap switches are operated to the "ON" position. This condition is an excellent indication of the satisfactory functioning of the plate circuits of all of the vacuum tubes.

In case one or more of the vacuum tube filaments is not lighted, this will be indicated by an abnormally high reading on the voltmeter and an abnormally low reading on the milliammeter. If an accidental ground occurs in any of the vacuum tube plate circuits, this will be indicated by a decrease in the voltmeter reading and an increase in the milliammeter reading. In case one of the individual plate circuit fuses blows out, this will be indicated in the same way as though one or more vacuum tube filaments were unlighted. After determining which piece of apparatus is at fault by finding which vacuum tube circuits do not give a plate current reading, the circuit should first be inspected for accidental grounds and short circuits and then, if clear, the plate circuit fuse (No. 62-B Fuse) should be replaced on the apparatus under test.

CAUTION:

DO NOT ATTEMPT TO REPLACE ONE OF THESE FUSES UNLESS
THE MAIN RECTIFIER SWITCH IS OPERATED TO THE "OFF"
POSITION.

AMPLIFIERS

The troubles most commonly encountered in amplifiers manifest themselves as noise, either regular or intermittent, which is audible at the output of the amplifier. Intermittent noises are due to defective "C" batteries or loose connections in some of the amplifier circuits. Low "C" battery voltage is indicated by an excessive plate current. Under this condition, all "C" batteries should be removed from the battery boxes and the voltage of each battery checked with a voltmeter. Also investigate the possibility of a poorly soldered connection between the brass spring contacts and zinc shells of the batteries.

Loose connections are usually difficult to locate because at the time of the test they may be making momentary contact. They can frequently be detected,

however, by moving the wiring back and forth while listening to a receiver connected across the output of the amplifier. It is always advisable to examine the contacts in the filament circuits, in particular the contacts between the vacuum tubes and the socket springs. If the tube contacts seem to be causing trouble, remove the tube and polish the contacts with fine sandpaper. It may also be necessary to bend up the contacts in the socket to improve the connection.

Regular noises may be caused by inductive interference, magnetic or acoustic coupling, or radio frequency pick-up. A steady low-pitched hum is usually a sign of inductive interference from a power circuit or electrical machine. Ordinarily it is picked up by the condenser transmitter circuits and, therefore, may be readily isolated from the amplifier. Interference of this nature may be eliminated by proper shielding and grounding.

A sustained high-pitched hum known as "singing" indicates magnetic or acoustic coupling or radio frequency pick-up. Magnetic coupling takes place when the input and output circuits of an amplifier are parallel for some distance without proper shielding. Acoustic coupling takes place when some of the sound energy from a receiver connected to the output of the amplifier strikes the condenser transmitter which is connected to the input. Trouble due to magnetic coupling may be cleared up by properly shielding and grounding the input leads. To destroy acoustic coupling it is only necessary to change the relative positions of the receiver and transmitter. One form of acoustic coupling which sometimes causes trouble is known as "microphonic effect." It is due to vibration of the elements of the vacuum tubes, and is observed when a monitoring loud speaker is operated at high level close to the tube. When excessive vibration is transferred to the tubes, the loud speaker should be moved or some form of cushioning employed to reduce it.

Radio frequency pick-up is one particularly baffling trouble which manifests itself only when the radio transmitter is operating close to the speech input equipment. In extreme cases, it may be bad enough to trip some of the overload relays in the radio transmitter. This trouble is also caused by insufficient or defective shielding or grounding in the input circuits. It usually shows itself at the time of installation rather than later, but if it arises suddenly, it is probably caused by the breaking of a ground connection somewhere. It may invariably be corrected by additional grounding, shielding, or both, after the portion of the circuit picking up the radio frequency is located.

Troubles which occur less frequently are open circuits and short circuits. Symptoms of these troubles depend largely on their location and the ease with which they are located depends largely on the operator's experience in tracing trouble in apparatus of this kind. The best procedure is to use the circuit diagram of the unit of apparatus as a guide and trace the trouble to its source by a process of elimination. If the trouble appears only when using the meters, it may be that trouble has developed somewhere in the meter cords.

SIGNAL CIRCUITS

In case of the failure of any of the indicating lights to function, the cause may be either a burned out lamp or the failure of contacts in that signal circuit, particularly the contacts of a relay, to function. Difficulties due to contact trouble both in the relay circuits and in the jacks, cords and plugs used in switching will generally be avoided by careful and regular routine inspection and maintenance.

In case trouble is experienced, however, with the indicating and relay operating circuits of the studio control system, such troubles can usually be most quickly and easily located by systematic testing with a voltmeter.

CONDENSER TRANSMITTER CIRCUITS

With proper care and use of the condenser transmitters and associated apparatus, no trouble should be experienced with this equipment. Ordinarily, any troubles which may be experienced with the condenser transmitter amplifiers can be located in the same manner as in the other amplifiers. The filament and plate current readings of these amplifiers offer a convenient check on their operation and will aid in localizing trouble.

If scratching sounds are heard at the output of one of the condenser transmitter amplifier circuits, or if no sound at all is heard when the circuit of the amplifier is in normal operating condition, it is usually an indication of a defective cord, a poor connection or, more rarely, of a short-circuit in the condenser transmitter itself.

APPARATUS INFORMATION

FUSES

No. 204-A Panel	4—No. 35-A Fuses (1½ amperes)
	1—No. 35-C Fuse (2 amperes)
	No. 35-F Fuses (½ ampere) as required
	2—No. 35-G Fuses (3 amperes)
	1—No. 35-H Fuse (5 amperes) if required
No. 8-C Amplifier	1—No. 62-B Fuse (0.25 ampere)
No. 18-B Amplifier	1—No. 62-B Fuse (0.25 ampere)
No. 203-B or C Panel	1—No. 62-B Fuse (0.25 ampere)
No. 1-B Rectifier	2—No. 91127 D & W Fuses (5 amperes)
AC Supply Circuit	2—No. 91133 D & W Fuses (10 amperes)
Battery Supply Circuit	2—No. 91133 D & W Fuses (10 amperes)

VACUUM TUBES

No. 8-C Amplifier	1—No. 102-G Vacuum Tube
	2—No. 205-D Vacuum Tubes
No. 18-B Amplifier	1—No. 205-D Vacuum Tube
No. 203-B or C Panel	1—No. 102-D Vacuum Tube
No. 1-B Rectifier	2—No. 214-E Vacuum Tubes
No. 47-B Amplifier	1—No. 239-A Vacuum Tube
No. 48-A Amplifier	1—No. 239-A Vacuum Tube

LAMPS

No. 203-B or C Panel Signal Circuits	1—No. D-80777 Ballast Lamp No. 2-F Lamps, as required
---	--

CORDS

No. 7-A Transmitter Mounting	1—No. M6B Cord (12 feet long)
	1—No. T2E Cord (4 inches long)
No. 8-A Transmitter Mounting	1—No. M6B Cord (12 feet long)
	1—No. T2E Cord (6 feet long)
No. 514-A Panel	1—No. 784 Cord (ammeter)
	1—No. 785 Cord (milliammeter)
Patching Cords	10—No. P2AA Cords (2 feet long)
	6—No. P2AA Cords (1 foot long)

SPARE PARTS

It is recommended that a stock of spare parts to be maintained consisting of the following items as a minimum :

2—No. D-80777 Ballast Lamps	4—D&W No. 91133, 10-Ampere Indicating Enclosed Fuses
26—No. 2-F Lamps	2—D&W No. 91127, 5-Ampere Indicating Enclosed Fuses
3—No. 205-D Vacuum Tubes	24—No. 35-A Fuses
2—No. 102-D Vacuum Tubes	6—No. 35-C Fuses
2—No. 102-G Vacuum Tubes	42—No. 35-F Fuses
2—No. 214-E Vacuum Tubes	12—No. 35-G Fuses
4—No. 239-A Vacuum Tubes	6—No. 35-H Fuses
2—General Electric Company Tungar Bulbs, Catalogue No. 189049	18—No. 62-B Fuses

INFORMATION FOR ORDERING REPLACEMENTS

It may be necessary, after some use of the equipment, to replace other parts. If this is necessary, it is suggested that in ordering replacement parts a

complete description of the apparatus required be given in the order. This description should include the code number, the specific apparatus of which the replacement is a part and the circuit designation marked on the apparatus to be replaced and confirmed by consultation with these instructions. The order should also note that the apparatus ordered is required for use in the No. 8-B Speech Input Equipment.

TELEPHONE SERVICE

Local operating telephone companies can usually provide circuits for both program and order wire service between the studio location and the radio station as well as from the outside points from which programs will be transmitted to the studio location.

Some companies are able to provide special circuits for program transmission in which equalizers are applied to the circuit to care for the distortion which occurs in a long telephone line. In general, cable circuits over three miles in length will cause serious distortion unless they are so equalized.

In the use of the telephone lines it is advisable to keep the power level on the line as high as possible without causing interference to adjacent lines. This interference level is generally determined by the local telephone companies. In the event that no requirement as to this level is specified, a power input of +2 db will normally be satisfactory. In most cases if the input level to a program line is +2 db a line having not more than 11 db loss will be satisfactory. However, special conditions may make it necessary to depart from these limits and the local telephone companies should be consulted with regard to their regulations for the use of broadcasting circuits.

Reference has been made in these instructions to the use of a 20-cycle supply for outgoing signalling on the order wire circuits. No apparatus is furnished for this purpose. The local telephone company should be requested to supply this service, as such companies are generally able either to supply 20-cycle power on a telephone pair on the same basis as a commercial power supply or to furnish apparatus for the generation of 20-cycle power at the studio location.

No telephone instruments are included in the equipment for talking on any of the order wire circuits, as it will generally be more satisfactory for the local operating companies to supply these instruments, as by so doing instruments can be supplied which will meet any special local conditions which may exist.

ENGINEERING SERVICE

If the user of this equipment desires engineering service the matter should be referred to the nearest branch house of the Graybar Electric Company and authorization for such service placed with them. In Canada this service may be obtained from the Northern Electric Company, Ltd., and in other foreign countries through the International Standard Electric Corporation.

INSTRUCTION BULLETIN No. 366

SCHEMATIC AND WIRING
DIAGRAMS

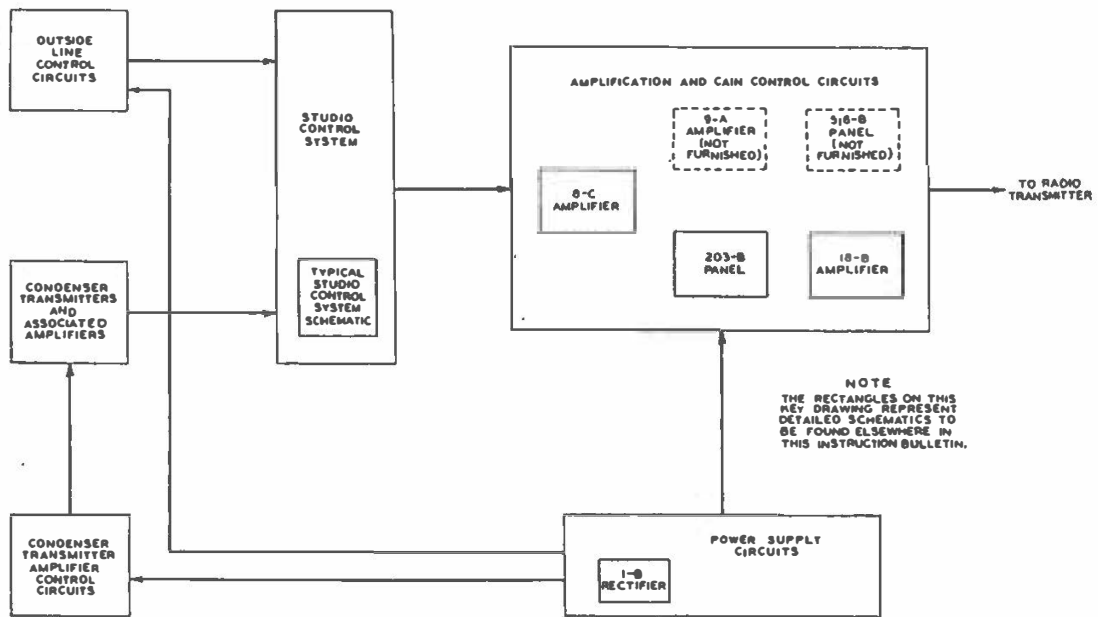

Key to Schematic Drawings

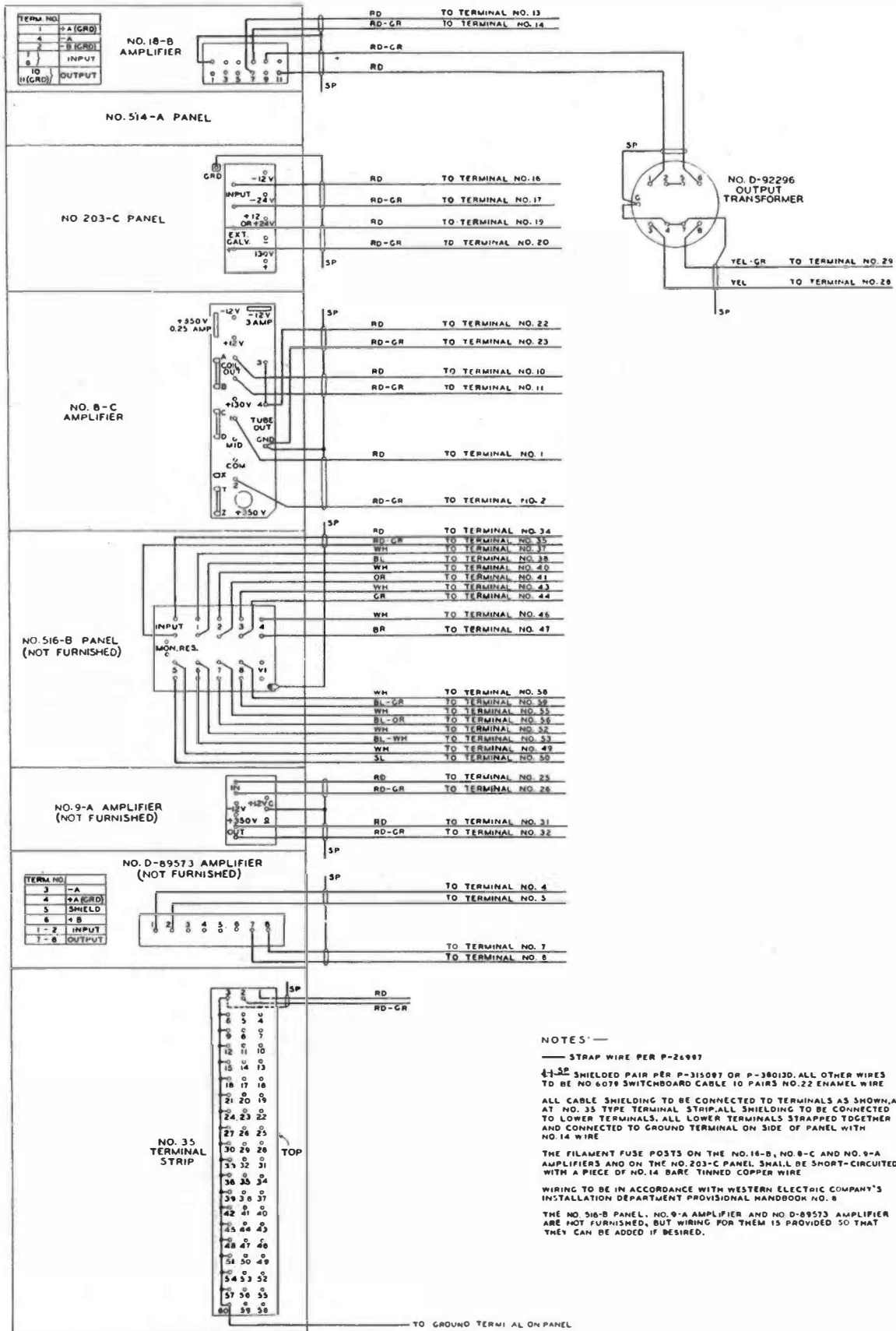

Wiring Diagram of No. D-87908 Amplifier Panel

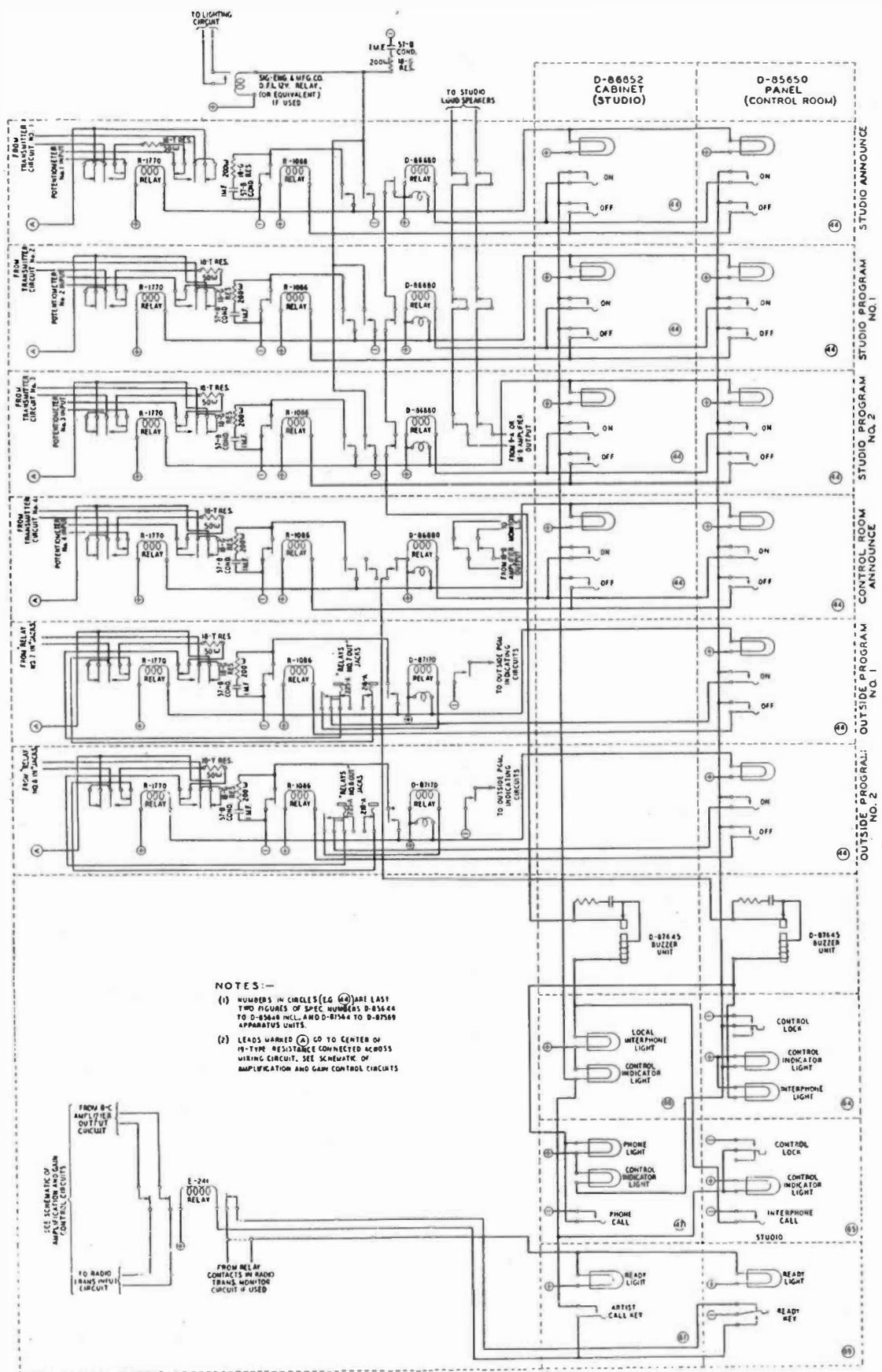

Schematic of Typical Studio Control System

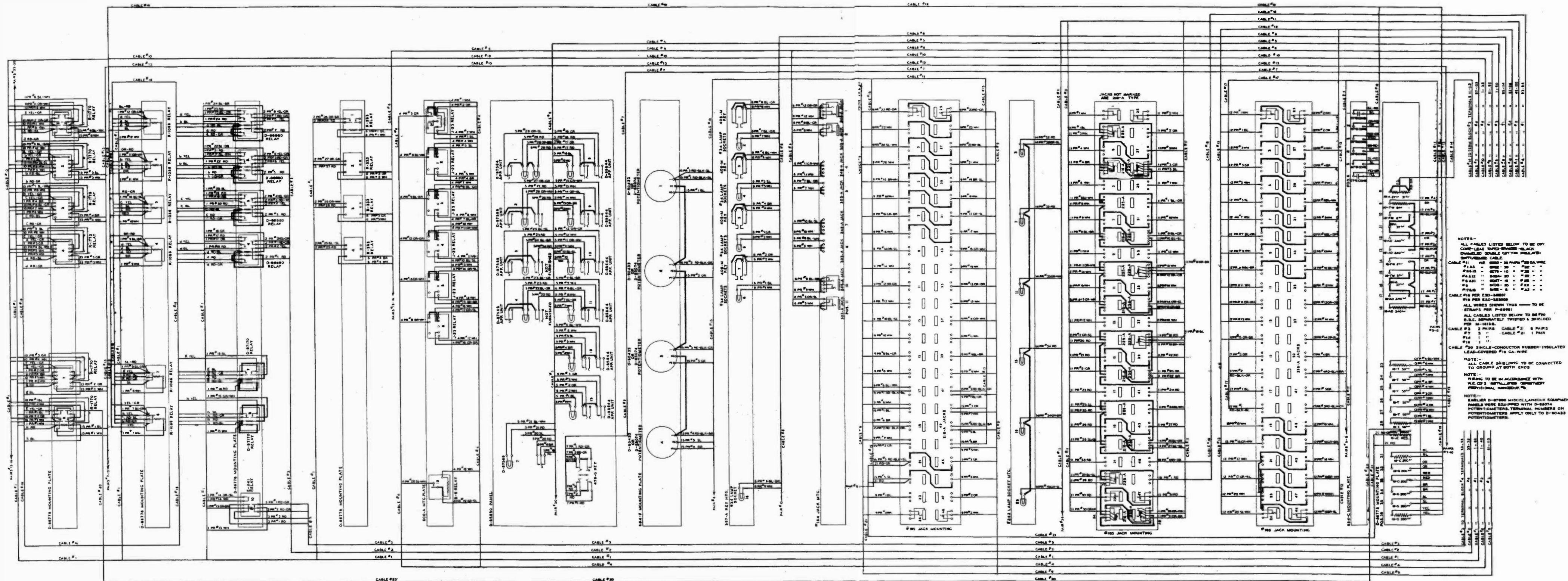

D-87990 Miscellaneous Equipment Panel Wiring Diagram

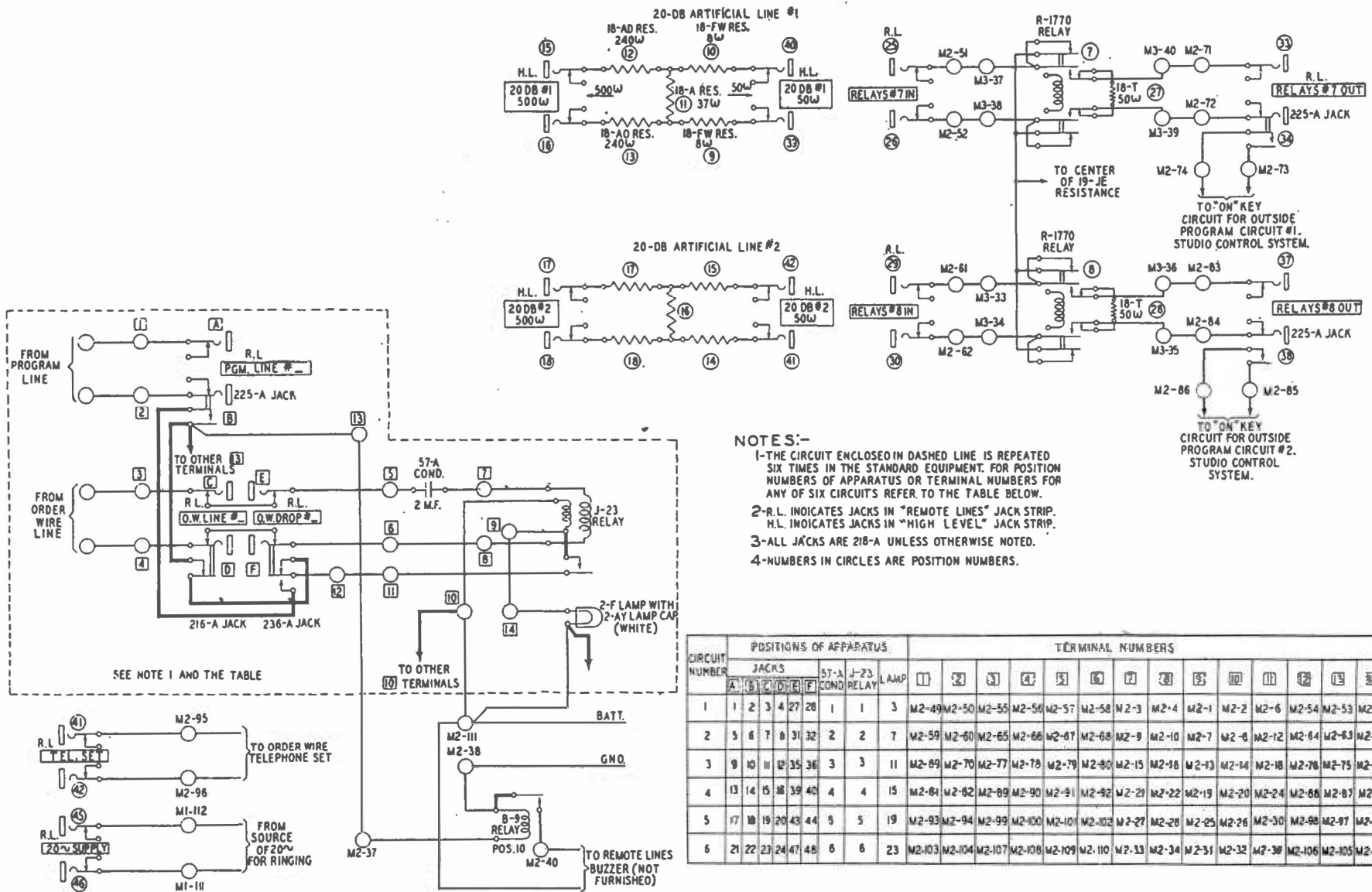

- NOTES:-**
- 1-THE CIRCUIT ENCLOSED IN DASHED LINE IS REPEATED SIX TIMES IN THE STANDARD EQUIPMENT. FOR POSITION NUMBERS OF APPARATUS OR TERMINAL NUMBERS FOR ANY OF SIX CIRCUITS REFER TO THE TABLE BELOW.
 - 2-R.L. INDICATES JACKS IN "REMOTE LINES" JACK STRIP. H.L. INDICATES JACKS IN "HIGH LEVEL" JACK STRIP.
 - 3-ALL JACKS ARE 218-A UNLESS OTHERWISE NOTED.
 - 4-NUMBERS IN CIRCLES ARE POSITION NUMBERS.

CIRCUIT NUMBER	POSITIONS OF APPARATUS						TERMINAL NUMBERS																
	JACKS						57-A COND.	J-23 RELAY	LAMP	11	12	13	14	15	16	17	18	19	20	21	22	23	24
	A	B	C	D	E	F				1	2	3	4	5	6	7	8	9	10	11	12	13	14
1	1	2	3	4	27	28	1	1	3	M2-49	M2-50	M2-55	M2-56	M2-57	M2-58	M2-3	M2-4	M2-1	M2-2	M2-6	M2-54	M2-53	M2-11
2	5	6	7	8	31	32	2	2	7	M2-59	M2-60	M2-65	M2-66	M2-67	M2-68	M2-9	M2-10	M2-7	M2-8	M2-12	M2-64	M2-63	M2-13
3	9	10	11	12	35	36	3	3	11	M2-69	M2-70	M2-77	M2-78	M2-79	M2-80	M2-15	M2-16	M2-13	M2-14	M2-18	M2-76	M2-75	M2-14
4	13	14	15	16	39	40	4	4	15	M2-81	M2-82	M2-89	M2-90	M2-91	M2-92	M2-21	M2-22	M2-19	M2-20	M2-24	M2-66	M2-67	M2-115
5	17	18	19	20	43	44	5	5	19	M2-93	M2-94	M2-99	M2-100	M2-101	M2-102	M2-27	M2-28	M2-25	M2-26	M2-30	M2-88	M2-87	M2-86
6	21	22	23	24	47	48	6	6	23	M2-103	M2-104	M2-107	M2-108	M2-109	M2-110	M2-33	M2-34	M2-31	M2-32	M2-38	M2-106	M2-105	M2-118

Schematic of Outside Line Control Circuits

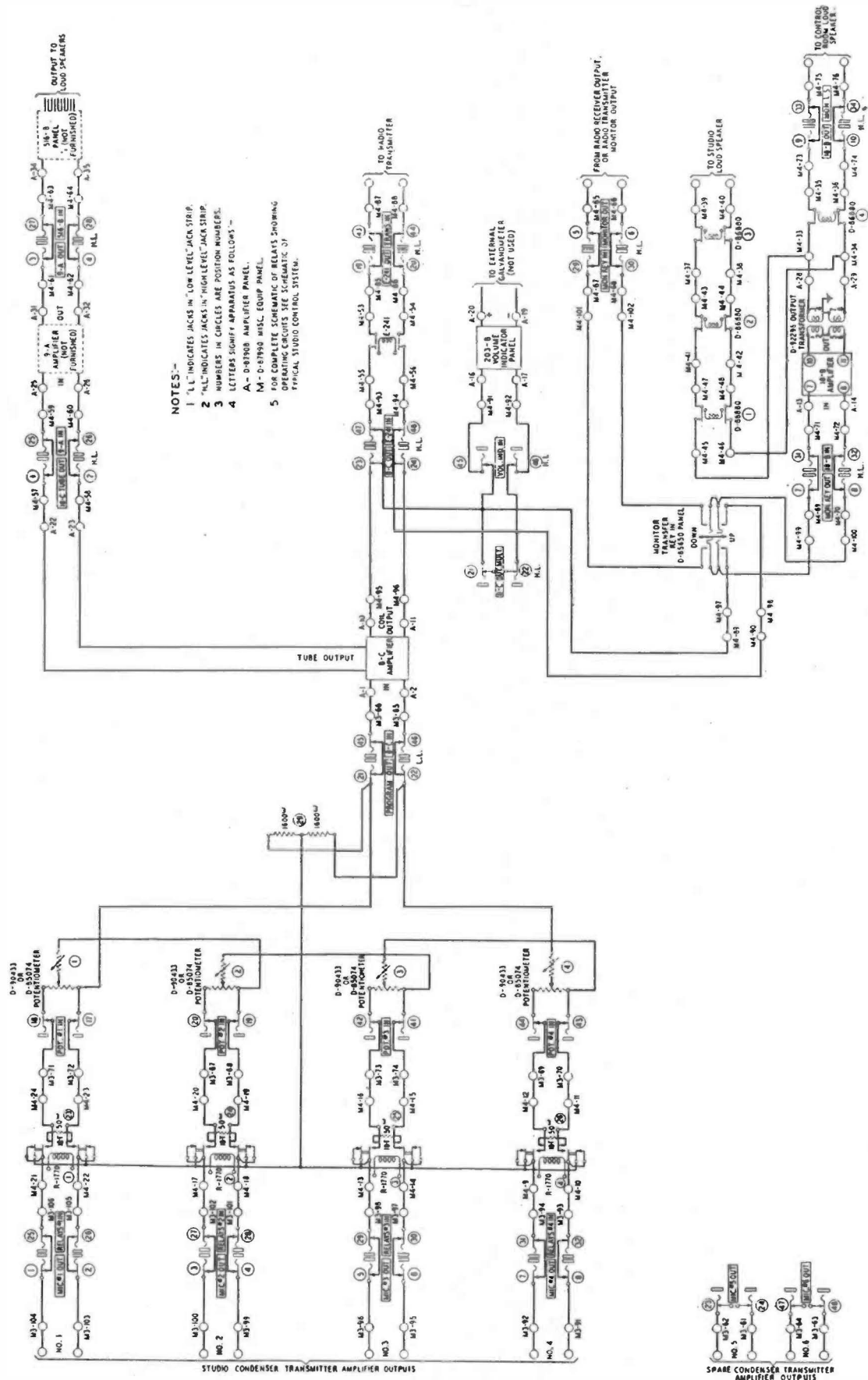

- NOTES:-
- 1 "LL" INDICATES JACKS IN "LOW LEVEL" JACK STRIP.
 - 2 "HL" INDICATES JACKS IN "HIGH LEVEL" JACK STRIP.
 - 3 NUMBERS IN CIRCLES ARE POSITION NUMBERS.
 - 4 LETTERS SIGNIFY APPARATUS AS FOLLOWS:-
A - D-87808 AMPLIFIER PANEL.
M - D-87808 MISC. EQUIP. PANEL.
 - 5 FOR COMPLETE SCHEMATIC OF RELAYS SHOWING OPERATING CIRCUITS, SEE SCHEMATIC OF TYPICAL STUDIO CONTROL SYSTEM.

Schematic of Amplification and Gain Control Circuits

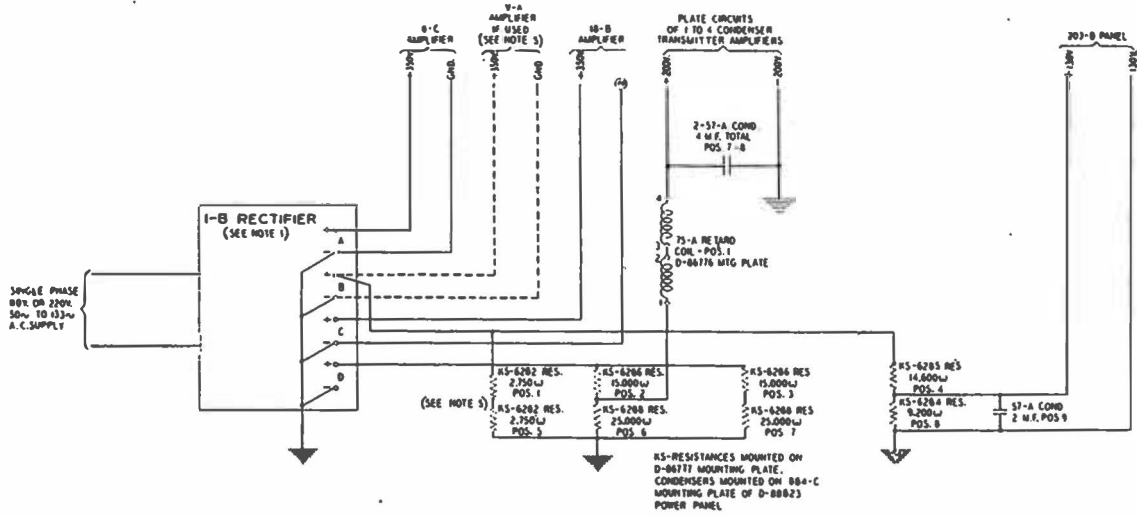

NOTES:-

- 1- WHEN I-B RECTIFIER IS USED ON 80 VOLT A.C. SUPPLY STRAP 1-2 AND 3-4 ON EACH TRANSFORMER TERMINAL BLOCK ON THE RECTIFIER ON 220 VOLT A.C. SUPPLY STRAP 2-3 ONLY ON EACH TRANSFORMER TERMINAL BLOCK.
- 2- THE FOLLOWING TUNGAR RECTIFIERS WILL BE FURNISHED WHEN POWER SUPPLY IS AS INDICATED.
105/125 V. 50-60 Hz - RS-3194, LIST NO. 1 (S.E. CO. CAT. # 3125421)
240/250 V. 50-60 Hz - RS-3194, LIST NO. 3 (S.E. CO. CAT. # 3125429)
- 3- LETTERS IN CIRCLES (THRU G) ARE CODE LETTERS OF 35 TYPE FUSES AS FOLLOWS:
35-A-15 AMP-WHITE DEAD
35-C-2 AMP-YELLOW DEAD
35-F-1/2 AMP-RED DEAD
35-G-3 AMP-BLUE DEAD
35-H-5 AMP-GREEN DEAD
- 4- POSITION NUMBERS REFER TO MOUNTING POSITIONS ON THE MOUNTING PLATES OF THE EQUIPMENT AS INDICATED.
- 5- THE 0-A AMPLIFIER IS NOT FURNISHED AS A PART OF THE 0-B SPEECH INPUT EQUIPMENT. WHEN THIS AMPLIFIER IS ADDED TO THE EQUIPMENT THE RS-RESISTANCES IN POSITIONS 1 & 5 ON THE D-86777 MOUNTING PLATE SHOULD BE REMOVED.

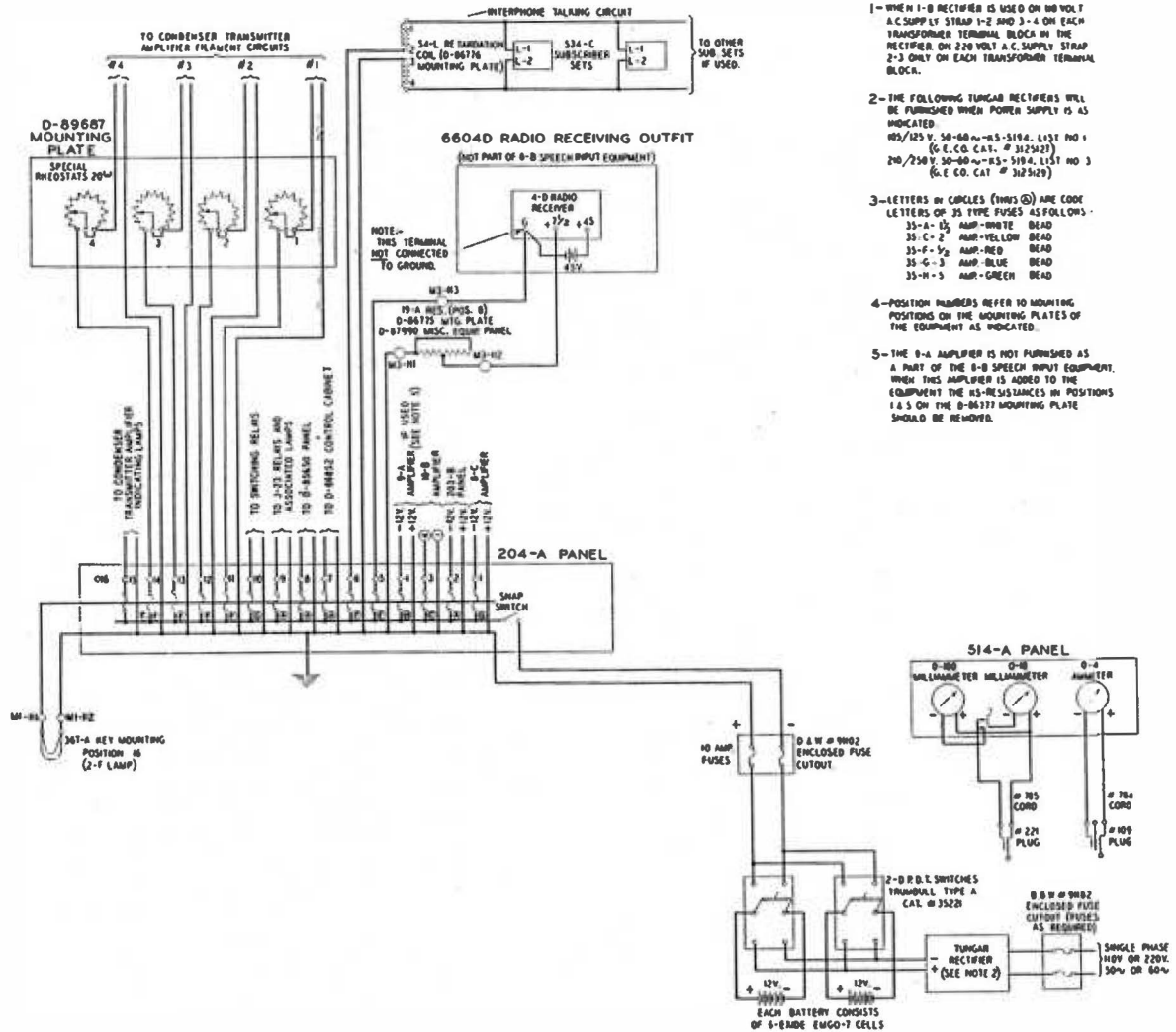

Schematic of Power Supply Circuits

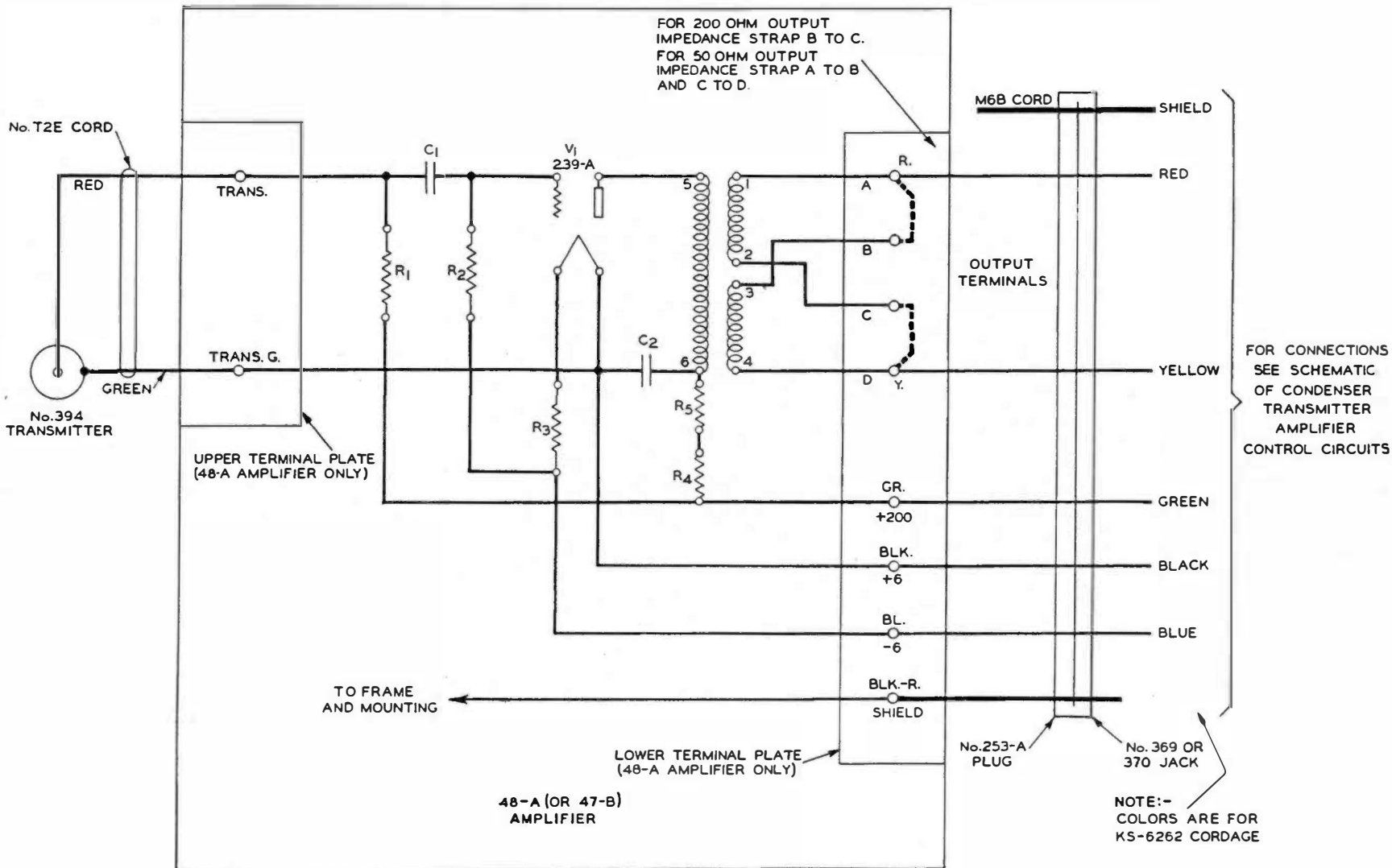

Schematic of No. 394 Transmitter and Associated Amplifier and Diagram of External Connections

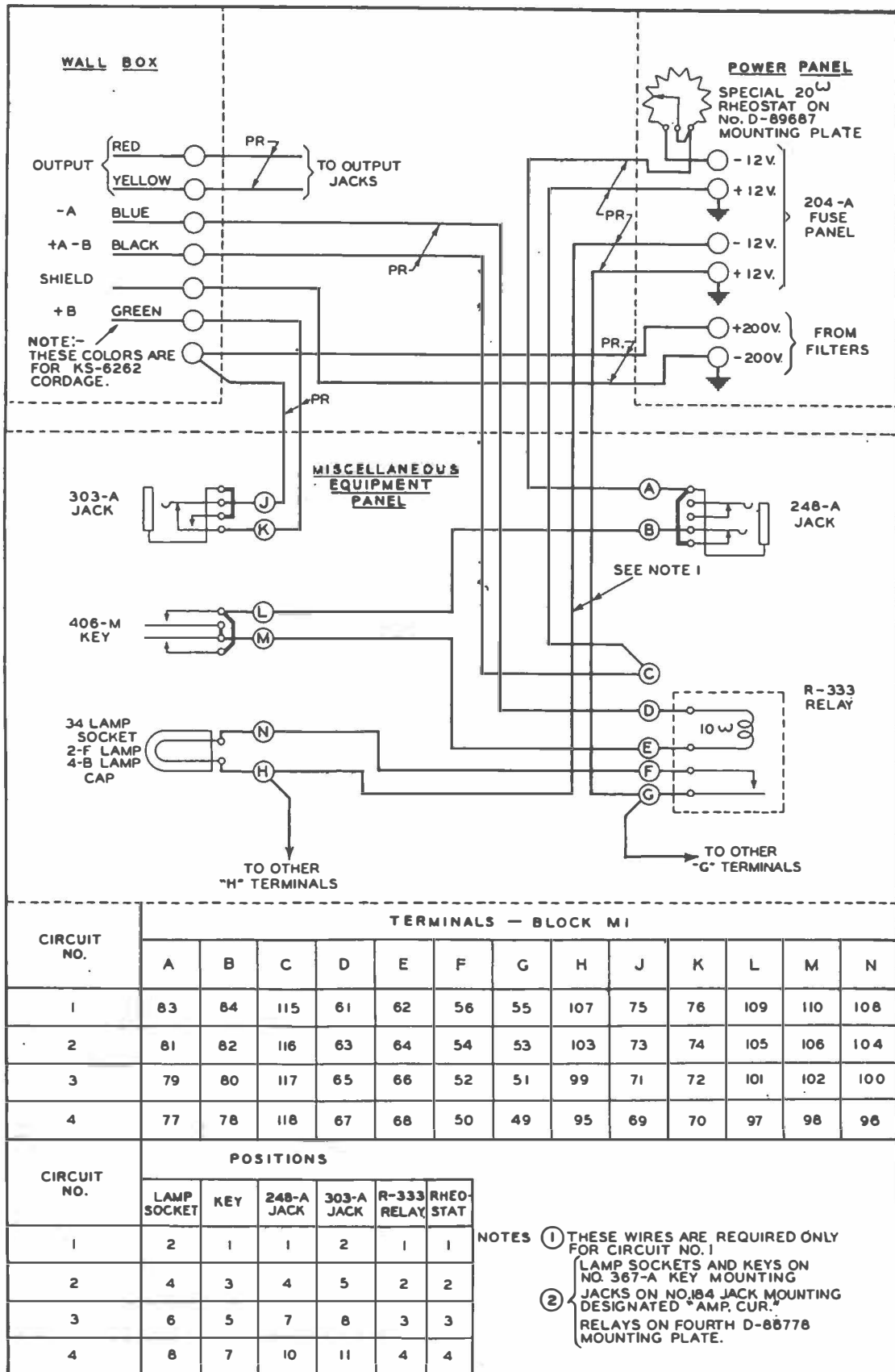

Schematic of Condenser Transmitter Amplifier Control Circuits

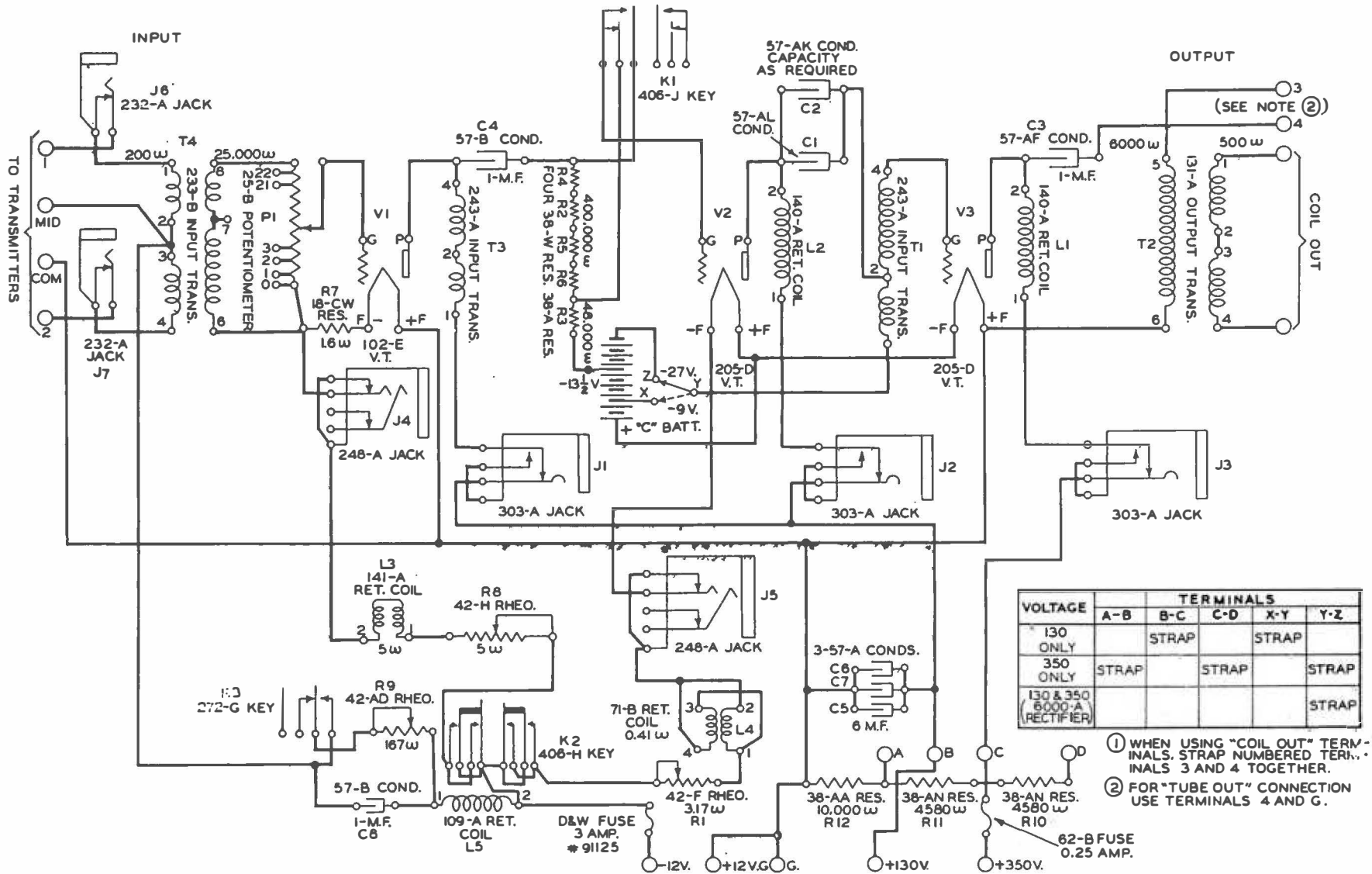

Schematic of No. 8-C Amplifier

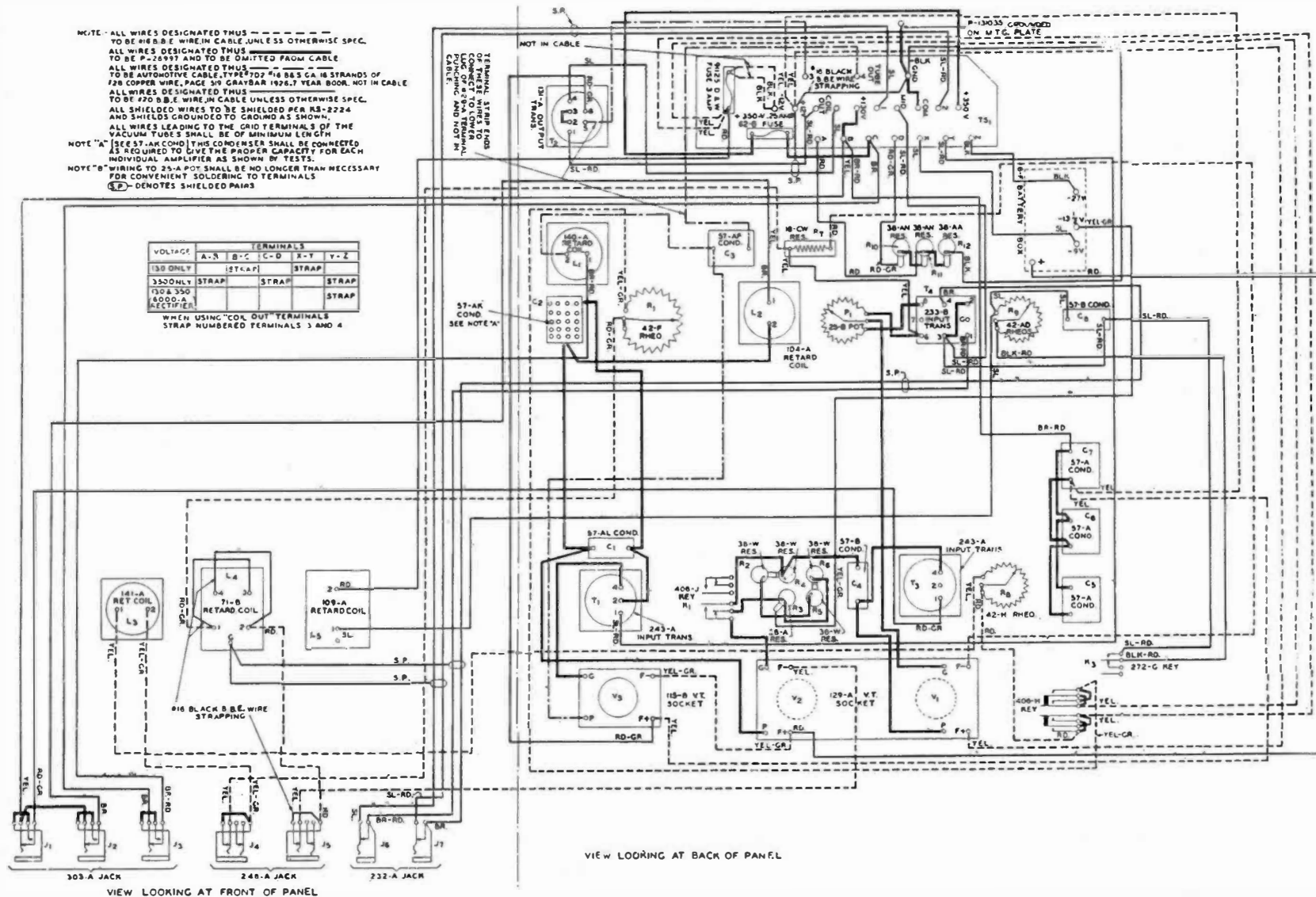

Wiring Diagram of No. 8-C Amplifier

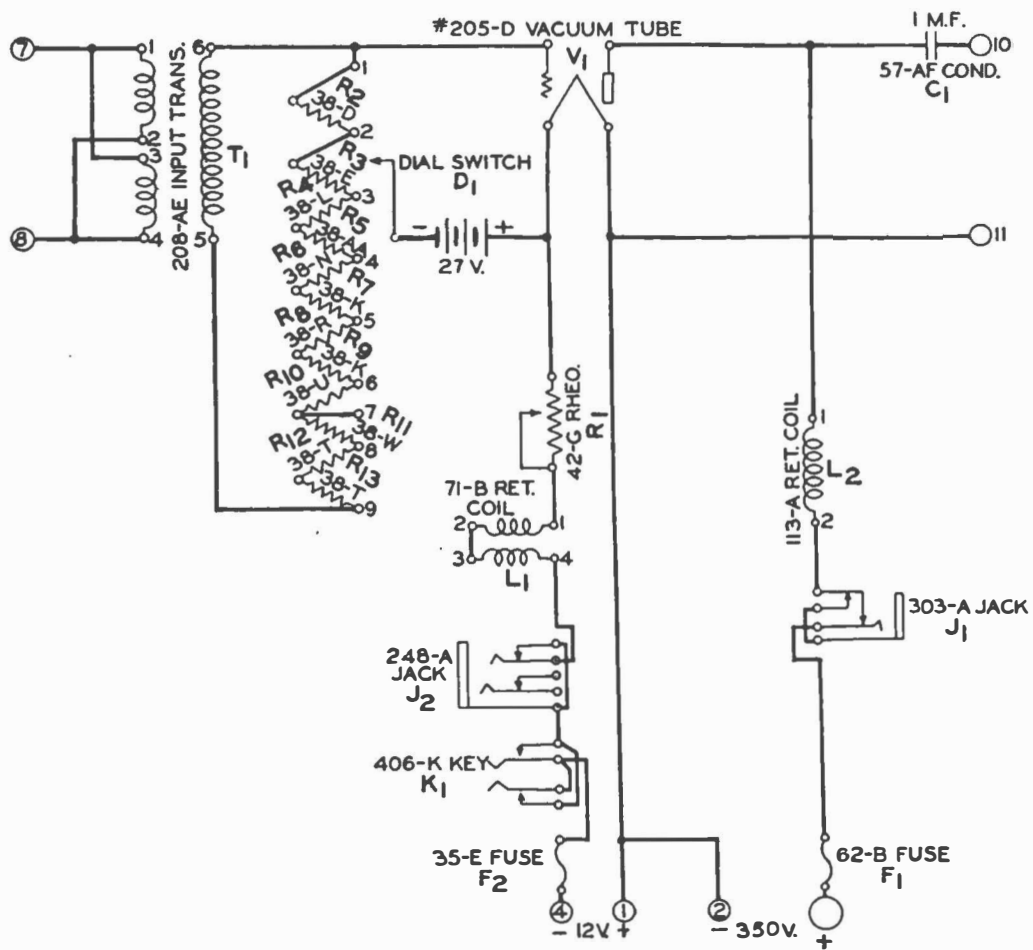

Schematic of No. 18-B Amplifier

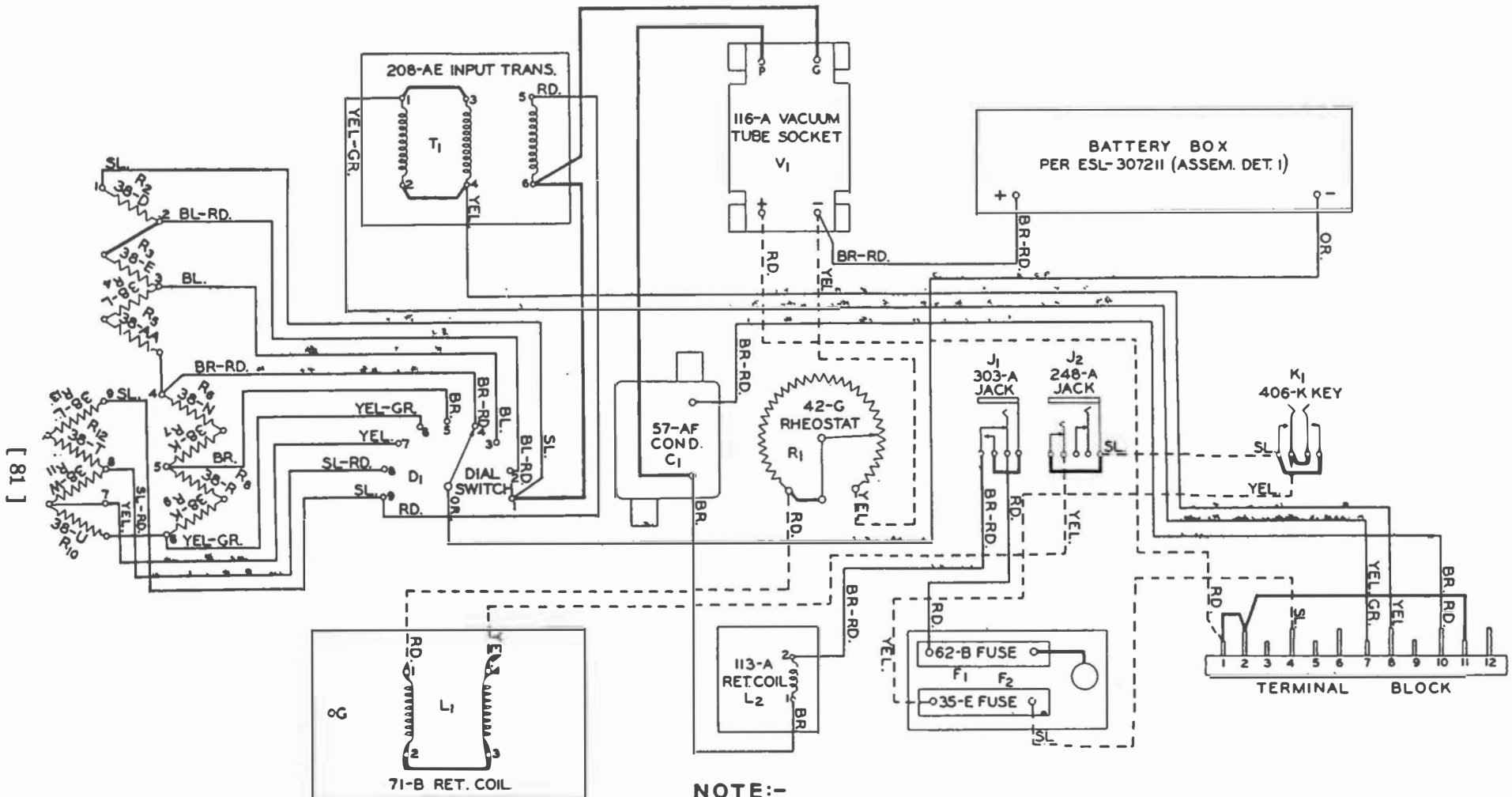

[18]

NOTE:-
 WIRES SHOWN THUS ----- TO BE #16 B.B.E
 WIRES SHOWN THUS ————— TO BE #16 B.B.E BLACK
 AND RUN SEPARATE AND AWAY FROM CABLE
 ALL OTHER WIRES TO BE #20 B.B.E
 (1) { MAIN BODY OF THE CABLE IS TO RUN APPROX-
 IMATELY 2 3/8" ABOVE THE PANEL

Wiring Diagram of No. 18-B Amplifier

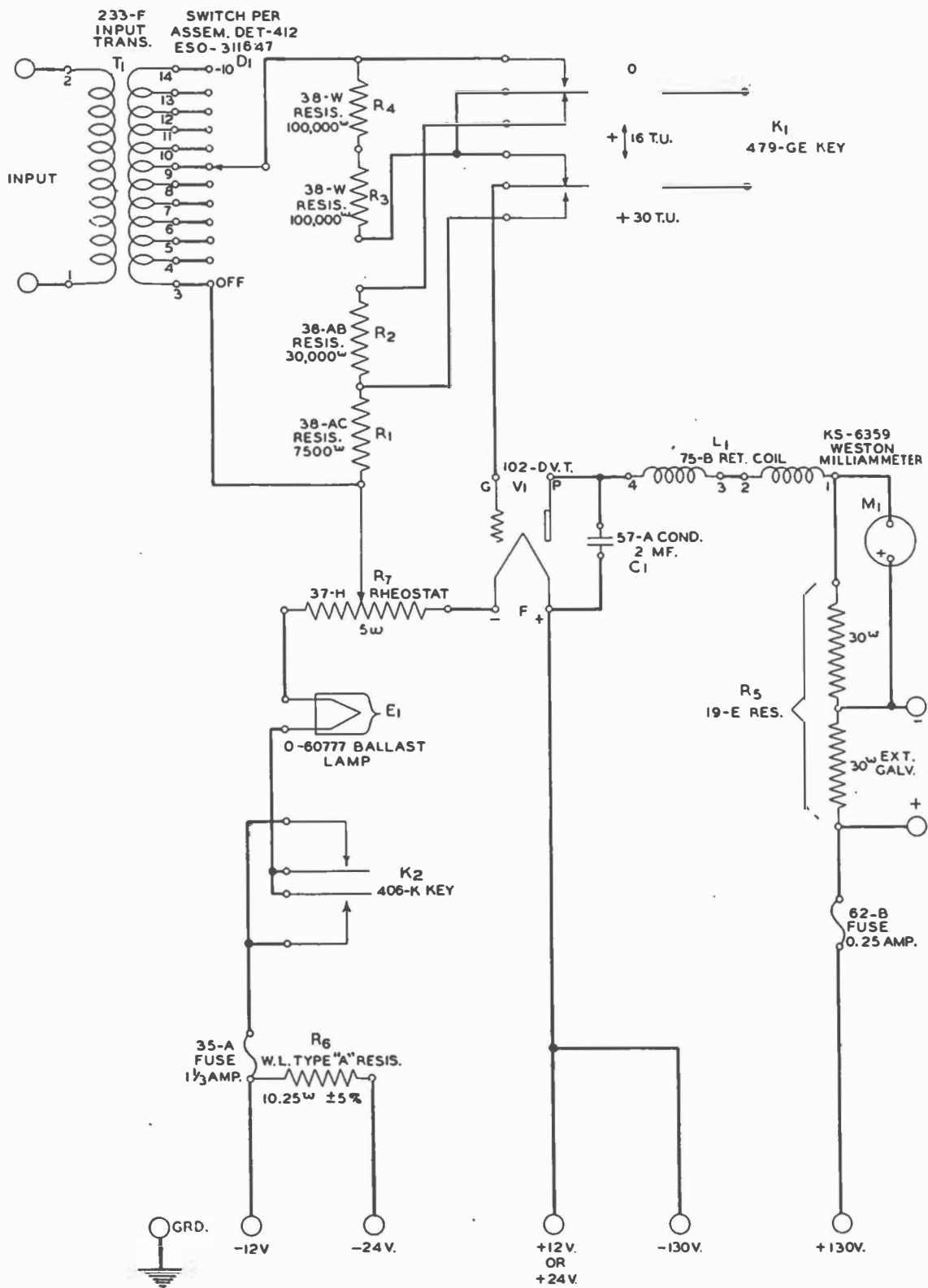

Schematic of No. 203-B Panel

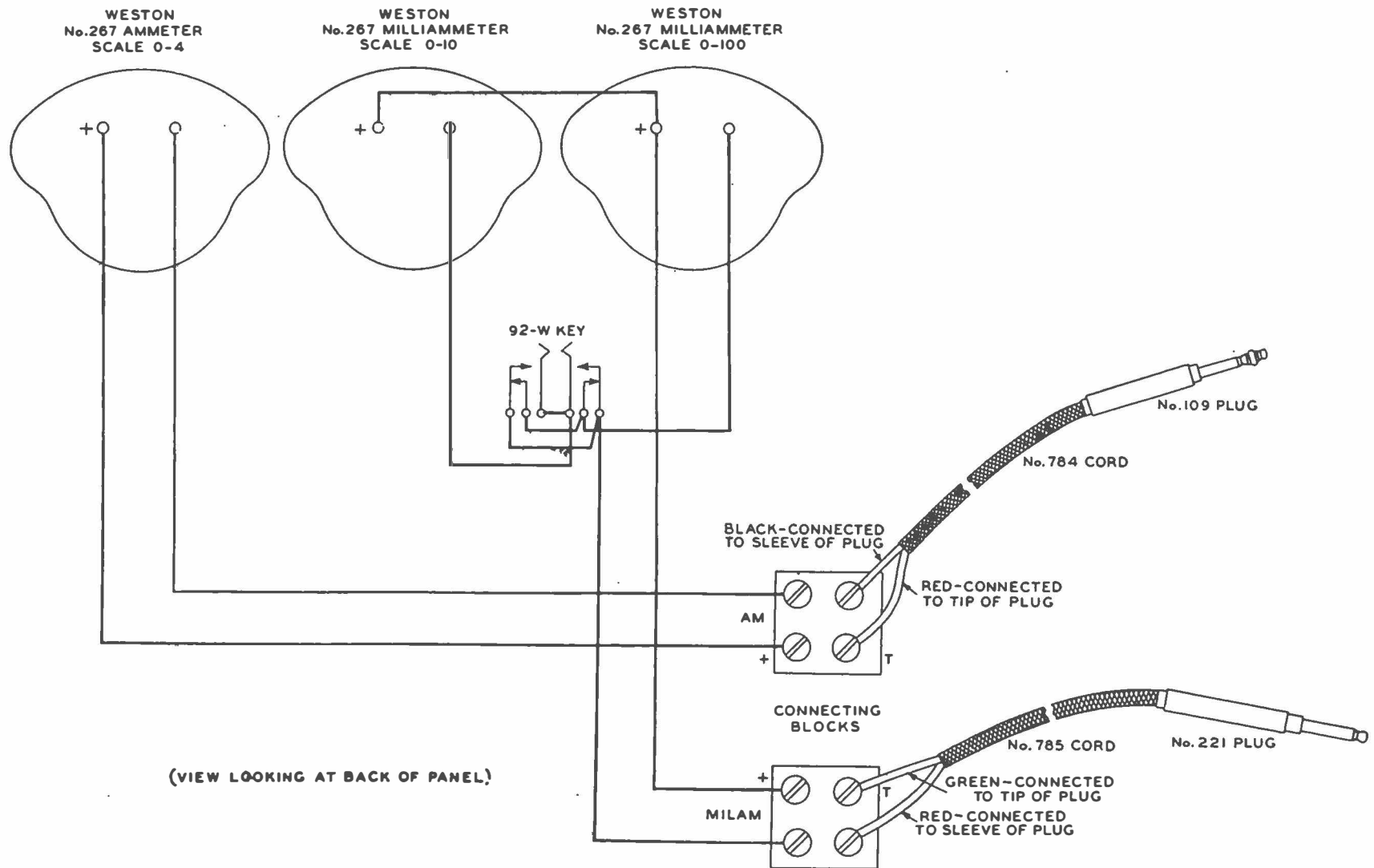

Wiring Diagram of No. 514-A Panel

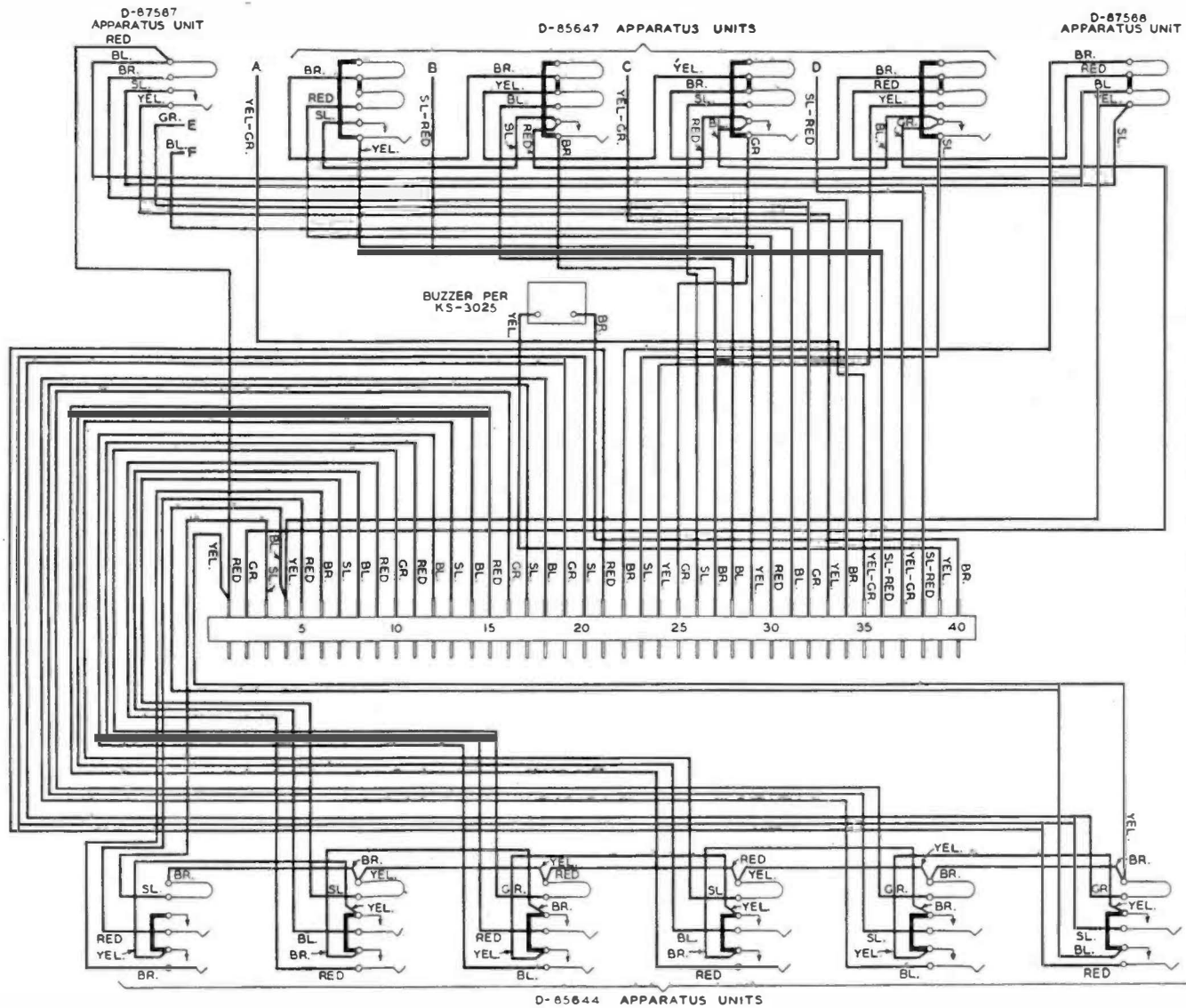

NOTE:-
 THE WIRING SHOWN COVERS A COMPLETELY EQUIPPED UNIT. WHEN D-85644 OR D-85347 APPARATUS UNITS ARE OMITTED THE CABLE SKINNERS PROVIDED FOR THESE UNITS ARE TAPED AND FOLDED BACK. WIRES A,B,C AND D ARE FOR USE WHEN D-85647 UNITS ARE REPLACED BY D-85644 UNITS. WIRES E & F ARE FOR USE WHEN UNIT D-87567 IS REPLACED BY A SPECIALLY EQUIPPED UNIT D-86123. THE ENDS OF THESE WIRES ARE NORMALLY TAPED AND FOLDED BACK.

NOTE:-
 WIRING TO BE No 20 B.B.E. WIRE PER A-300001.
 STRAPPING TO BE P-26997.

VIEW LOOKING AT BACK OF UNIT

Wiring Diagram of No. D-86852 Control Cabinet

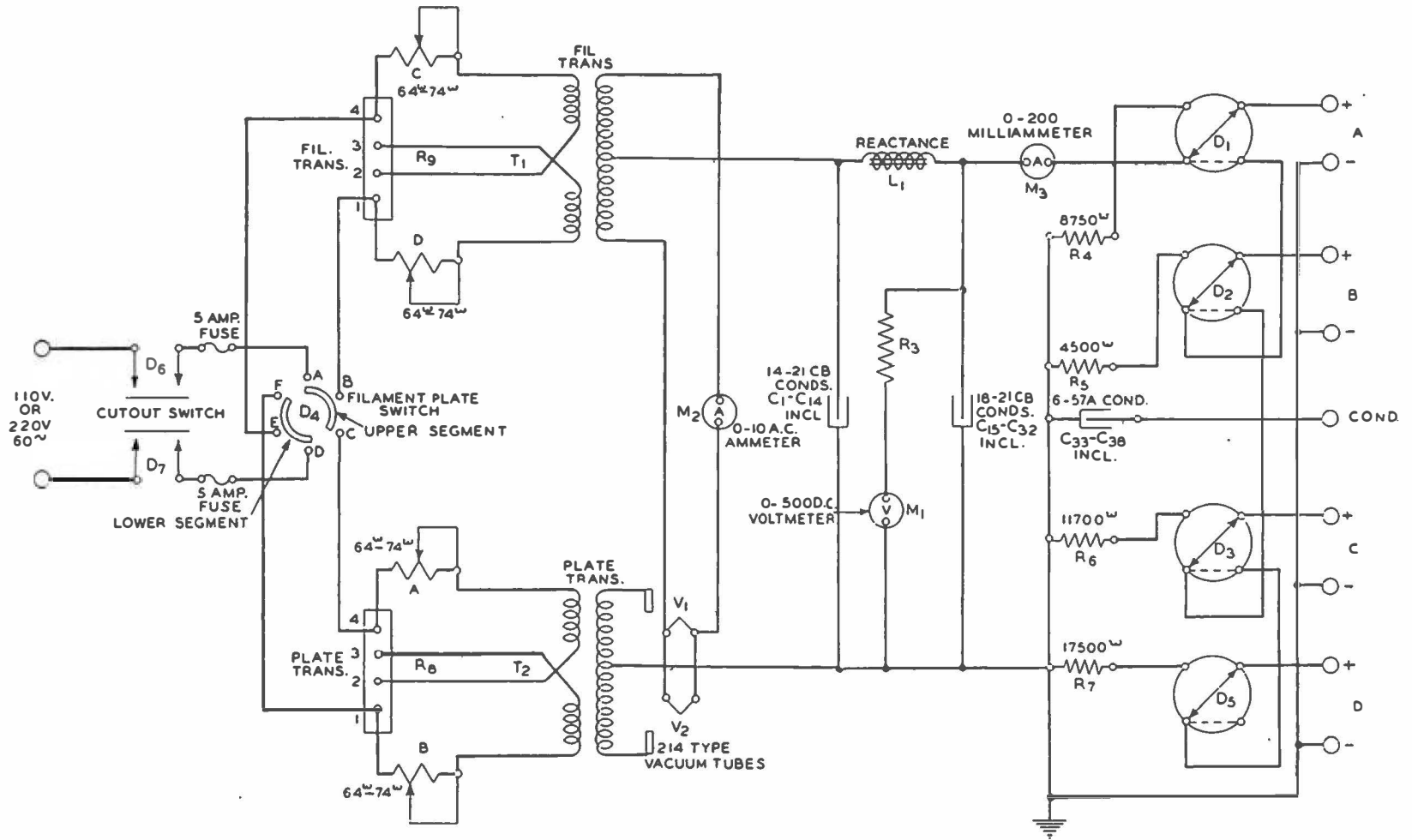

FIL. PLATE SWITCH
 POS. 1, FIL. A & B, D & E ARE CLOSED.
 POS. 2, PLATE AB & C, DE & F ARE CLOSED
 POS. 3, OFF A & B, D & E ARE OPEN.

4" RHEOSTATS "A & B" ARE OPERATED BY SAME HANDLE.
 4" RHEOSTATS "C & D" ARE OPERATED BY SAME HANDLE.
 ON 110V. CIRCUIT STRAP 1-2 & 3-4 ON EACH TRANS. TERM. BLOCK.
 ON 220V CIRCUIT STRAP 2-3 ONLY ON EACH TRANS TERM. BLOCK.

Schematic of No. 1-B Rectifier

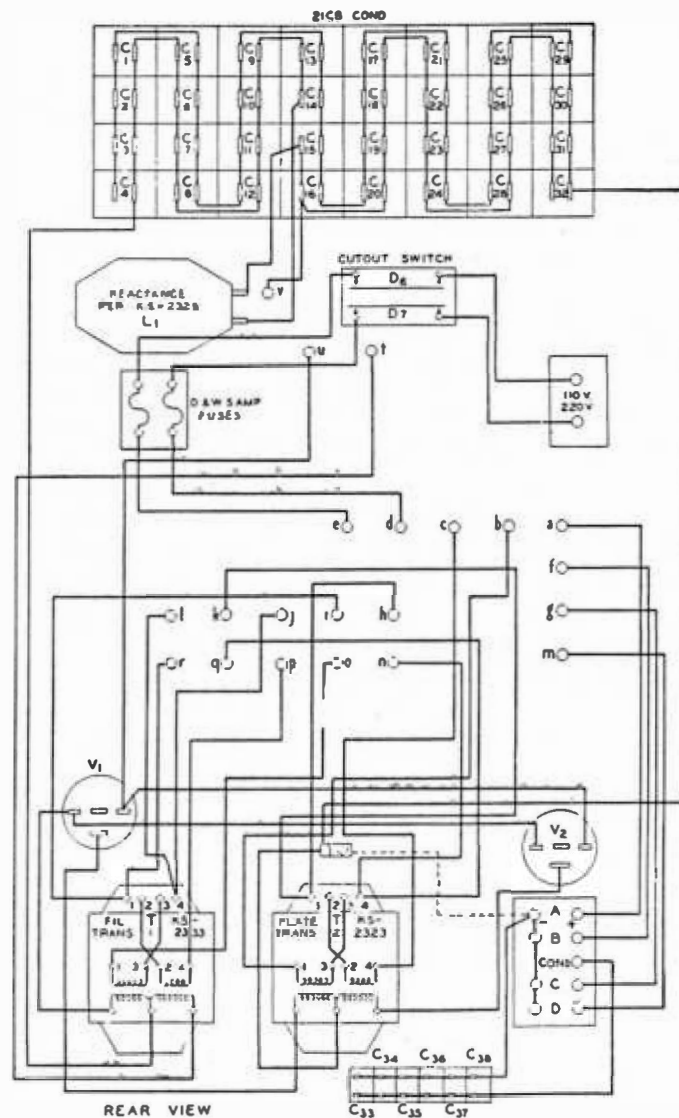
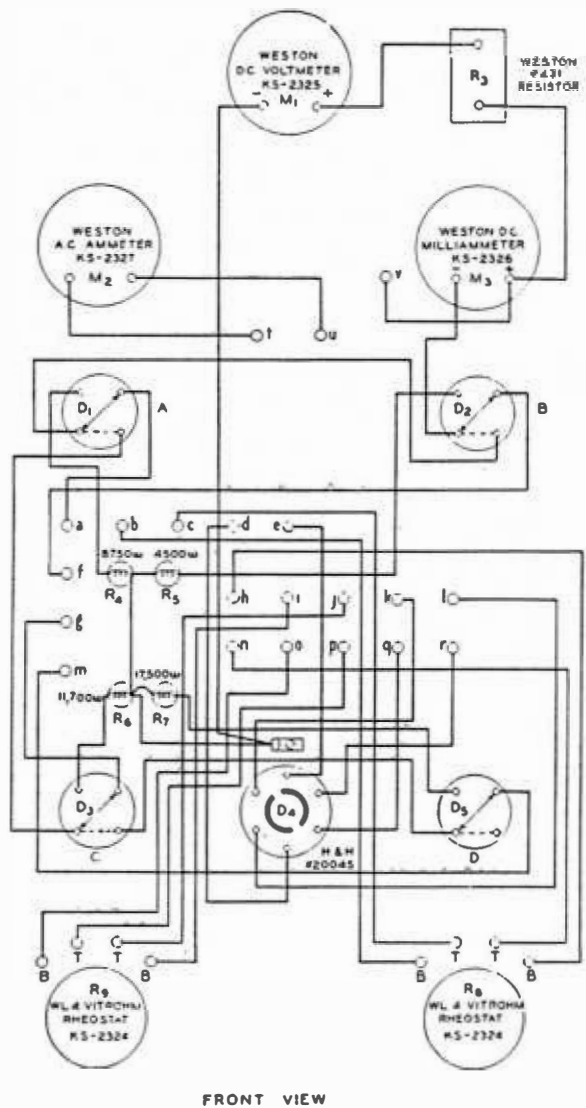

NOTE:-
USE #14 SOLID RUBBER COVERED
SINGLE BRAIDED 600 VOLT WIRE.
WIRES FROM 110-220V. TERMINALS
TO "e" AND "d" HOLES, AND WIRE
FROM THE MIDDLE TERMINAL OF FIL.
TRANS TO CONDENSERS TO BE RUN
IN GREENFIELD LOOM
ON FRONT AND REAR VIEWS
DESIGNATIONS a,b,c, ETC INDICATE
BUSHINGS

Wiring Diagram of No. 1-B Rectifier

INDEX

- Adjustment of Apparatus, 45
 - Meter Indications, 47
 - Starting, 45
 - Stopping, 48
- Amplification and Gain Control Circuits,
 - Schematic of, 12, 74
- Amplifiers
 - No. 8-C
 - adjustment, 45, 47
 - description, 27
 - front view, 28
 - rear view, 29
 - schematic, 26, 78
 - wiring diagram, 79
 - No. 9-A
 - description, 3
 - No. 18-B
 - adjustment, 45, 46
 - description, 31
 - front view, 30
 - rear view, 30
 - schematic, 31, 80
 - wiring diagram, 81
 - No. 47-B
 - description, 21
 - illustration, 21
 - schematic, 22, 76
 - No. 48-A
 - description, 21
 - illustration, 23
 - schematic, 22, 76
- Amplifier Panel
 - No. D-87908
 - description, 2
 - wiring diagram, 69
- Amplifiers, Location of Trouble in, 62
- Apparatus Blank, No. D-86122, 9
- Apparatus Information
 - Cords, 65
 - Fuses, 65
 - Lamps, 65
 - Ordering Replacements, 65
 - Spare Parts, 65
 - Vacuum Tubes, 65
- Apparatus Units
 - No. D-85644, 3, 9, 43
 - No. D-85647, 42
 - No. D-87564, 8
 - No. D-87565, 8
 - No. D-87567, 7, 42
 - No. D-87568, 42
 - No. D-87569, 7, 8
- Batteries
 - Charge and Discharge Cycles, 19
 - Charging, 53
 - Charging Equipment, 20
 - Dry, 27, 31
 - Maintenance of, 55
 - Storage, 19
 - Trouble, Location of, 61
 - Typical Installation, 19
- Circuits
 - Amplification and Gain Control, Schematic of, 12, 74
 - Condenser Transmitter Amplifier Control Circuits, Schematic of, 25, 77
 - Outside Line, Operation of, 50
 - Outside Line, Schematic of, 6, 70
 - Program and Order Wire, 66
 - Typical Studio Control System, Schematic of, 6, 70
- Condenser Transmitters, see Transmitters
- Control Cabinet
 - No. D-86852
 - description, 41
 - front view, 41
 - rear view, 42
 - wiring diagram, 85
- Cords
 - List of, 65
 - Maintenance of, 58
- Decibel, Definition of, 33
- Diagrams, Schematic and Wiring, 67-87
- Drawings, Key to Schematic, 2, 68
- Engineering Service, 66
- Equipment, Maintenance, 59

- Filament Power Supply, 19
- Fuses, List of, 65
- Gain Control Circuits, Schematic of Amplification and, 12, 74
- Interphone Telephone Set, 43
- Jack Mounting
 - No. 184, 9
 - No. 185, 11
- Jack Strip Designation, 14
- Jacks
 - Maintenance of, 58
 - No. 369, 21
 - No. 370, 21
- Key Mounting, No. 367-A, 8, 9
- Keys
 - Maintenance of, 58
 - No. 406-M, 8
 - No. 479-G, 9
- Lamp Socket Mounting, No. 262, 8, 11
- Lamps
 - List of, 65
 - Maintenance of, 58
- Maintenance Equipment, 59
- Maintenance of Apparatus
 - Batteries, 55
 - Cords, 58
 - Jacks, 58
 - Keys, 58
 - Lamps, 58
 - Plugs, 58
 - Potentiometers, 59
 - Relays, 56
 - Rheostats, 59
 - Vacuum Tubes, 55
- Meter Indications, 47
- Miscellaneous Equipment Panel
 - No. D-87990
 - description, 3
 - front view, 4
 - rear view, 5
 - wiring diagram, 71
- Monitoring, 52
- Mounting Plates
 - No. 600-A, 8
 - No. 884-C, 15
 - No. 884-F, 9
 - No. D-86775, 3, 13
 - No. D-86776, 15
 - No. D-86777, 15
 - No. D-86778, 3, 8
 - No. D-87339, 3, 13
 - No. D-89687, 15
 - No. D-90758, 15
- Operation of Apparatus
 - Battery Charging, 53
 - Condenser Transmitters, 49
 - Monitoring, 52
 - Outside Line Circuits, 50
 - Studio Control System, 49
 - Volume Indicator, 51
- Output Transformer, No. D-92296, 3
- Outside Line Control Circuits, Schematic of, 10, 73
- Outside Line Circuits, Operation of, 50
- Panel Assemblies, 2
- Panels
 - No. 203-B (also No. 203-C)
 - adjustment, 45, 47
 - description, 33
 - front view, 32
 - rear view, 32
 - schematic, 34, 82
 - wiring diagram, 83
 - No. 204-A
 - adjustment, 45, 48
 - description, 15
 - No. 514-A
 - description, 35
 - front view, 36
 - wiring diagram, 37, 84
 - No. 516-B
 - description, 3
 - No. D-85650
 - description, 3, 8
 - No. D-87908 Amplifier
 - description, 2
 - wiring diagram, 69
 - No. D-87990 Miscellaneous Equipment
 - description, 3
 - front view, 4
 - rear view, 5
 - wiring diagram, 71

Panels (*Continued*)

No. D-88823 Power
adjustment, 45
description, 15
front view, 16
rear view, 17
schematic of power supply circuits, 18, 75

Parts, Spare, 65

Plate Supply, Location of Trouble in, 62

Plates, Mounting, see Mounting Plates

Plug, No. 253-A, 21

Plugs, Maintenance of, 58

Potentiometers

No. 33-A, 9
No. D-85074, 9
No. D-90433, 9

Potentiometers, Maintenance of, 59

Power Panel, No. D-88823

adjustment, 45
description, 15
front view, 16
rear view, 17
schematic of power supply circuits, 18, 75

Power Supply, Filament, 19

Power Supply Circuits, Schematic of, 18, 75

Radio Receiving Outfit, No. 6604-D, for Monitoring, 52

Rectifier

No. 1-B
adjustment, 45, 46, 48
description, 36
front view, 38
rear view, 39
schematic, 40, 86
wiring diagram, 87

Relays

No. B-9, 8
No. D-86880, 4, 5, 7, 9
No. D-87170, 4, 5, 7, 9
No. E-241, 4, 7, 8
No. E-285, 8
No. J-23, 8

Relays (*Continued*)

No. R-333, 8
No. R-1086, 3, 4, 5, 9
No. R-1770, 3, 4, 7, 9

Relays, Maintenance of, 56

Replacements, Ordering of, 65

Rheostats, Maintenance of, 59

Retardation Coils

No. 54-L, 15
No. 75-A, 15
No. 148-A, 15

Schematic and Wiring Diagrams, 67-87

Schematic Drawings, Key to, 2, 68

Signal Circuits, Location of Trouble in, 64

Spare Parts, 65

Starting Apparatus, 45

Stopping Apparatus, 48

Studio Control System

Description of, 3, 8, 41
Operation of, 49
Schematic of Typical, 6, 70

Telephone Service, Program and Order Wire, 66

Telephone Set, Interphone, 43

Transformer, No. D-92296 Output, 3

Transmitter Mountings

No. 7-A
description, 21
illustration, 23
No. 8-A
description, 21
illustration, 24

Transmitters and Associated Apparatus

Amplifier, No. 47-B (Condenser Transmitter)
description, 21
illustration, 21

Transmitters and Associated Apparatus
(Continued)

Amplifier, No. 48-A (Condenser Transmitter)

description, 21
illustration, 23

Cords

No. M6B, 21
No. T2E, 21

Jacks

No. 369, 21
No. 370, 21

Plug, No. 253-A, 21

Transmitter, No. 394 (Condenser Transmitter)

adjustment, 46
description, 20
illustration with shipping box, 20
location of trouble in circuits, 64
operation, 49
schematic of transmitter amplifier control circuits, 25, 77
schematic with associated apparatus, 22, 76

Transmitters and Associated Apparatus
(Continued)

Transmitter Mountings

No. 7-A
description, 21
illustration, 23

No. 8-A
description, 21
illustration, 24

Trouble, Location of

Amplifiers, 62
Battery Supply, 61
Condenser Transmitter Circuits, 64
Plate Supply, 62
Signal Circuits, 64

Vacuum Tubes

List of, 65

Maintenance of, 55

Volume Indicator, 51

Wiring Diagrams, Schematic and, 67-87

