

SCHEMATIC OF THE 270A OUTPUT SWITCHING PANEL

A development of Bell Telephone Laboratories, the research laboratories of the American Telephone and Telegraph Company and the Western Electric Company

DISTRIBUTOR IN THE UNITED STATES
Graybar
ELECTRIC COMPANY

DISTRIBUTOR FOR CANADA AND NEWFOUNDLAND
Northern Electric Company
LIMITED

General Offices and Plant: 1261 Shearers Street, Montreal, P. Q.

FOREIGN DISTRIBUTORS

International Standard Electric Corporation
67 Broad Street New York, U. S. A.



Western Electric Output Switching Panel

270A

For Radio Telephone Broadcasting Systems

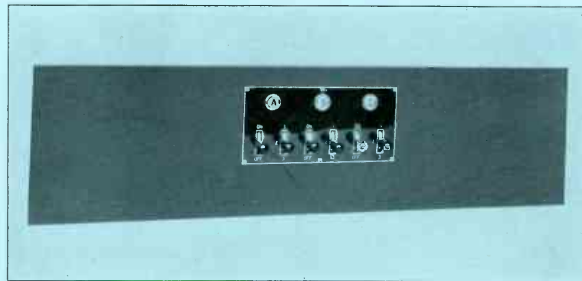

270A OUTPUT SWITCHING PANEL

THE Western Electric 270A Output Switching Panel provides facilities for the assignment of any one, combination of two or maximum of three speech input amplifier channels to any one of three outgoing circuits. These output circuits may be used for local audition purposes, or for direct connection to an adjacent radio transmitter. They may also be used in conjunction with repeating coils and telephone lines to furnish programs to networks or to radio transmitters situated remotely from the studio.

The 270A panel is designed to operate between 500 ohm impedances and will accommodate input power levels as high as 24 milliwatts (+ 16 db on a 6 milliwatt "zero level" basis). Resistance networks maintain constant impedance relations in the connecting circuits irrespective of the switching combinations employed. The in-

sertion loss introduced by these coupling networks is 10 db.

The components are assembled on a recessed metal panel, equipped with a face mat which serves as a mounting for the designation plate associated with the control keys and indicating lamps.

There are six lever type keys and three signal lamps. Three keys are employed to assign the various studio channels to the outgoing circuits. Each key is connected to a particular studio amplifier system or channel and is locking in both up and down positions. The other three keys and the three signal lamps are for control of the output circuits of three studio channels by means of relays external to the panel. These keys are non-locking in the "On" positions and locking in the "Off" positions.

Four terminal strips are provided for external connections.

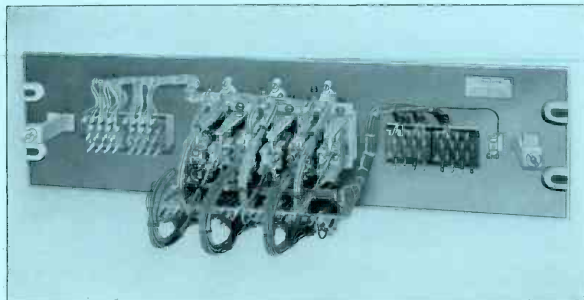

REAR VIEW OF THE 270A OUTPUT SWITCHING PANEL

SPECIFICATIONS:

Input: Input impedance is 500 ohms for each of three available circuits. Will accommodate input levels up to 24 milliwatts.

Output: Three output circuits of 500 ohms each.

Power supply: 12 volts battery supply is required for the operation of the relay control circuit if this is employed for remote control of the studio output channels.

Dimensions: 19 1/4" wide by 5 1/4" high.

Mounting: Standard relay rack or equipment cabinet.

Weight: Approximately 7 1/2 pounds.

Finish: Dark Gray or black mat as specified:

- 270A-15—Gray mat
- 270A-3 —Black mat

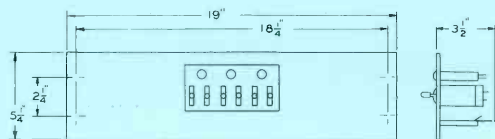

DIMENSIONAL DRAWING OF THE 270A OUTPUT SWITCHING PANEL

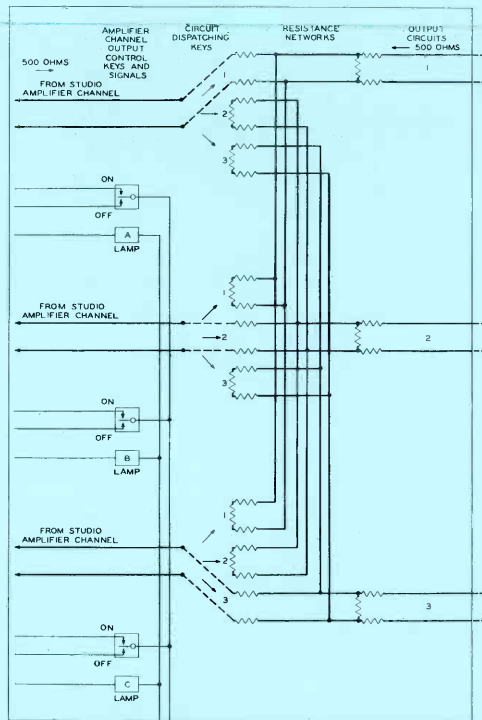

TO CONTROL CIRCUIT POWER SUPPLY (12 VOLTS DC)
 NOTE: LEVERS OF ON-OFF KEYS ARE NON-LOCKING IN THE ON POSITIONS AND LOCKING IN THE OFF POSITIONS

FUNCTIONAL DIAGRAM, 270A OUTPUT SWITCHING PANEL

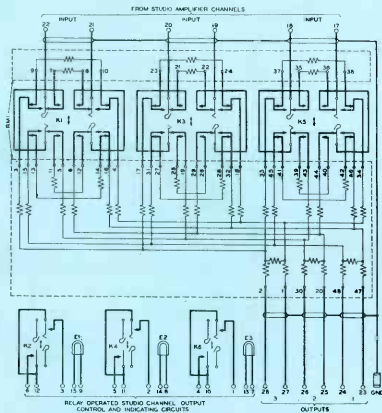

SCHEMATIC OF THE 270A OUTPUT SWITCHING PANEL.

A development of Bell Telephone Laboratories, the research laboratories of the American Telephone and Telegraph Company and the Western Electric Company

DISTRIBUTOR IN THE UNITED STATES
Graybar
ELECTRIC COMPANY

DISTRIBUTOR FOR CANADA AND NEWFOUNDLAND
Northern Electric Company
LIMITED

General Offices and Plant: 1261 Shearer Street, Montreal, P. Q.

FOREIGN DISTRIBUTORS

International Standard Electric Corporation
67 Broad Street New York, U. S. A.



Western Electric Output Switching Panel

270A

For Radio Telephone Broadcasting Systems

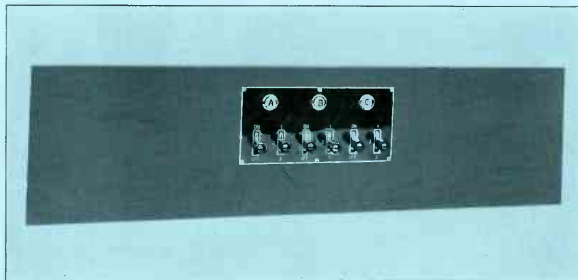

270A OUTPUT SWITCHING PANEL

THE Western Electric 270A Output Switching Panel provides facilities for the assignment of any one, combination of two or maximum of three speech input amplifier channels to any one of three outgoing circuits. These output circuits may be used for local audition purposes, or for direct connection to an adjacent radio transmitter. They may also be used in conjunction with repeating coils and telephone lines to furnish programs to networks or to radio transmitters situated remotely from the studio.

The 270A panel is designed to operate between 500 ohm impedances and will accommodate input power levels as high as 24 milliwatts (+ 16 db on a 6 milliwatt "zero level" basis). Resistance networks maintain constant impedance relations in the connecting circuits irrespective of the switching combinations employed. The in-

sertion loss introduced by these coupling networks is 10 db.

The components are assembled on a recessed metal panel, equipped with a face nut which serves as a mounting for the designation plate associated with the control keys and indicating lamps.

There are six lever type keys and three signal lamps. Three keys are employed to assign the various studio channels to the outgoing circuits. Each key is connected to a particular studio amplifier system or channel and is locking in both up and down positions. The other three keys and the three signal lamps are for control of the output circuits of three studio channels by means of relays external to the panel. These keys are non-locking in the "On" positions and locking in the "Off" positions.

Four terminal strips are provided for external connections.

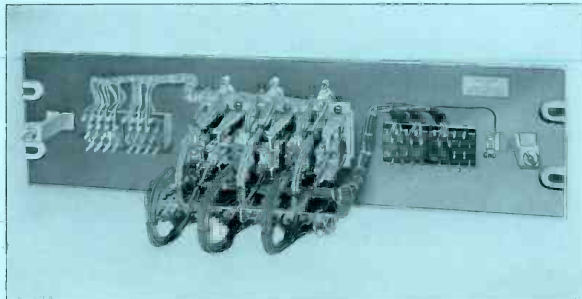

REAR VIEW OF THE 270A OUTPUT SWITCHING PANEL

SPECIFICATIONS:

Input: Input impedance is 500 ohms for each of three available circuits. Will accommodate input levels up to 24 milliwatts.

Output: Three output circuits of 500 ohms each.

Power supply: 12 volts battery supply is required for the operation of the relay control circuit if this is employed for remote control of the studio output channels.

Dimensions: 19 1/4" wide by 5 1/4" high.

Mounting: Standard relay rack or equipment cabinet.

Weight: Approximately 7 1/2 pounds.

Finish: Dark Gray or black mat as specified:

- 270A-15—Gray mat
- 270A-3 —Black mat

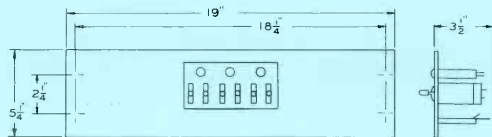

DIMENSIONAL DRAWING OF THE 270A OUTPUT SWITCHING PANEL

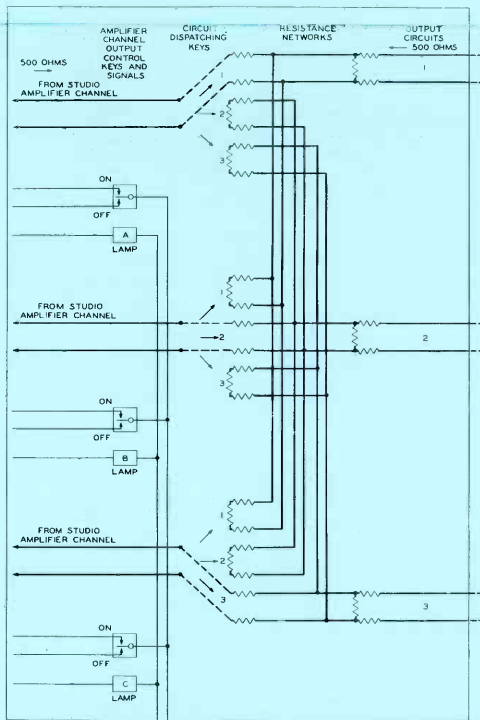

TO CONTROL
CIRCUIT POWER
SUPPLY (12 VOLTS DC)

NOTE: LEVERS OF ON-OFF KEYS ARE NON-LOCKING
IN THE ON POSITIONS AND LOCKING
IN THE OFF POSITIONS

FUNCTIONAL DIAGRAM, 270A OUTPUT SWITCHING PANEL