



I. B. 81-220-1

# INSTRUCTIONS

TYPE FM-3

## 3 KW FREQUENCY MODULATED BROADCAST TRANSMITTER

SEPTEMBER, 1948

**WESTINGHOUSE ELECTRIC CORPORATION**  
INDUSTRIAL ELECTRONICS DIVISION • BALTIMORE, MARYLAND

## **SPECIAL INQUIRIES**

When communicating with Westinghouse in reference to the equipment described by this instruction book, include *all* information contained on the nameplate attached to the equipment. Also, to facilitate replies when particular operational data is desired, be sure to state fully and clearly the information wanted. Please address all communications to the nearest Westinghouse District Office.

## WARNING

The use of high voltages which are dangerous to life is necessary for the operation of the electronic equipment covered by these instructions. While all practical safety precautions have been incorporated in the design of this equipment, they are not infallible; therefore, certain precautionary measures must be carefully observed by the operating personnel during the operation, inspection and maintenance of the equipment.

**KEEP AWAY FROM LIVE CIRCUITS**— Do not reach into an enclosure or handle any portion of the externally installed units without first removing the power and grounding the circuit.

**OBSERVE EXTREME CAUTION WHEN SERVICING OR ADJUSTING THE EQUIPMENT**—Do not connect any apparatus external to the enclosure, to circuits within the equipment, or apply voltages to the equipment for testing purposes while any non-interlocked portion of the shielding or enclosure is removed or opened. Connection of apparatus external to the enclosure in addition to being a hazard may cause failure of the interlock circuits.

**DO NOT TAMPER WITH INTERLOCKS**—Under no circumstances should any door or safety interlock be removed or short circuited, nor should interlocks be relied on for removing voltages from the equipment.

**DO NOT DEFEAT THE MECHANICAL INTERLOCK SYSTEM BY THE USE OF DUPLICATE KEYS.**

# TABLE OF CONTENTS

<b>I. INTRODUCTION.....</b>	<b>1-15</b>
Introduction.....	1
Units of the Transmitter.....	1
Location of the Components.....	1
Vacuum Tubes Required.....	7
 <b>II. INSTALLATION, ADJUSTMENT AND OPERATION.....</b>	 <b>17-38</b>
Space Requirements for the Installation.....	17
Installing the Transmitter Cubicle.....	17
Installing the Plug-In Units.....	19
Removing Packing Material Inside Cubicle.....	19
Unblocking Relays and Contactors.....	19
Connections to the Transmitter.....	19
Preliminary Adjustments.....	22
Adjustment of Cubicle Control Circuits.....	22
Crystal Heater Power Circuit.....	23
Distribution Bus Control Circuit.....	23
Filament and Distribution Bus Circuits.....	23
Motor-Driven Tuning Circuits.....	24
Measuring Filament Voltages.....	24
Table of Filament Voltages.....	24
Checking Low Voltage Supply.....	24
Adjusting Low Voltage Regulator.....	24
Tuning the Type MO and Type MP Units.....	25
Adjusting Modulator Plate Current.....	25
Tuning the Crystal Oscillators.....	25
Tuning the Modulated Oscillator Grid Circuit.....	25
Adjusting Mixer Grid Current Control—MP Unit.....	27
Tuning the Tripler Grid Control—MO Unit.....	27
Tuning the Tripler Plate Circuit—MO Unit.....	27
Tuning the Intermediate Amplifier Plate Circuit—MO Unit.....	27
Discriminator Tuning Adjustment.....	27
Pulse Balance Adjustment.....	28
Check of Cathode Follower V-313.....	28
Tuning the Driver Stage.....	28
Adjusting the 3-Kilowatt Amplifier.....	30
Summary.....	33
Operation.....	33
Remote Controls and Indicators.....	33
Placing the Transmitter on the Air.....	38
Removing the Transmitter from the Air.....	38
Operating the Transmitter as a Driver.....	38
 <b>III. THEORY OF OPERATION.....</b>	 <b>39-57</b>
General Functioning of the Circuits.....	39
Radio Frequency Generating Circuits.....	39
Audio Frequency Modulating Circuits.....	39
Frequency Stabilizing Circuits.....	41
Radio Frequency Amplifying Circuits.....	41
D-c Rectifier Circuits.....	42
A-c Distribution and Control Circuits.....	42

*units readings*

## TABLE OF CONTENTS (Cont.)

Detailed Functioning of the Circuits.....	42
Radio Frequency Generating Circuits.....	42
Frequency Modulated Oscillator—Tripler.....	42
R-F Tripler Stage.....	43
R-F Intermediate Amplifier.....	43
Audio Frequency Modulating Circuits.....	43
Audio Frequency Amplifier Stage.....	43
Modulator Control Tube.....	45
Diode Modulator.....	45
Audio Feedback Discriminator.....	45
Frequency Stabilizing Circuits.....	46
Buffer Amplifier.....	46
Crystal Oscillators.....	46
Phase Shift Networks.....	47
#1 Mixer Stage.....	47
#2 Mixer Stage.....	47
Relationship Between Mixer Outputs.....	47
Mixer Amplifiers.....	48
Multivibrator Stage.....	48
Pulse Discriminator.....	48
Pulse Amplifier.....	50
Pulse Limiter.....	50
Pulse Integrator.....	50
Cathode Follower.....	52
Frequency Control Switch.....	52
Frequency Control Indicator Light.....	52
Voltage Supply Circuits.....	52
Radio Frequency Amplifying Circuits.....	54
Driver Stage.....	54
3 Kilowatt Amplifier Stage.....	54
R-F Voltmeter Rectifier.....	54
D-C Rectifier Circuits.....	55
Low Voltage Rectifier.....	55
2,500 Volt Rectifier.....	55
Cubicle Voltage Regulator.....	55
A-C Distribution and Control Circuits.....	55
Primary A-C Control and Distribution Circuits.....	55
Applying Filament Voltage.....	56
Turning On the 400 Volt Rectifier.....	56
Turning On the 2,500 Volt Rectifier.....	56
Master Overload Circuits.....	57
Auxiliary Relay Circuits.....	57
Motor-Driven Control Circuits.....	57
<b>IV. MAINTENANCE AND TROUBLESHOOTING .....</b>	<b>59-62</b>
Maintenance.....	59
Safety Precautions.....	59
Cleaning the Equipment.....	59
Checking Air Filter.....	59
Tube Replacements.....	59
Metal Rectifiers.....	59
Relay Adjustments.....	60
Bliley TC92 Crystal Units.....	60

## TABLE OF CONTENTS (Cont.)

Check of Meters.....	60
Troubleshooting Indications.....	60
Radio Frequency Generating Circuits.....	60
Audio Frequency and Modulating Circuits.....	60
Frequency Stabilizing Circuits.....	61
Buffer Amplifier.....	61
Crystal Oscillators.....	61
Phasing Networks and Mixers.....	71
Amplifier.....	61
Multivibrator.....	61
Pulse Discriminator.....	61
Pulse Integrator.....	61
Radio Frequency Amplifier Stages.....	62

## LIST OF ILLUSTRATIONS

*Tab numbers for Illustrations follow RED "illustrations" Tab*

<i>Figure</i>	<i>Title</i>	<i>Location</i>
1-1	The Westinghouse Type FM-3, 3 Kilowatt Frequency Modulated Broadcast Transmitter (Photo C-11542).....	vi
1-2	The Type FM-3 Broadcast Transmitter, Front View, Front Access Doors Open (Photo C-11543).....	2
1-3	The Type FM-3 Broadcast Transmitter, Rear View, Access Doors Open (Photo C-11527).....	4
1-4	The Type FM-3 Broadcast Transmitter, Rear View, Access Doors Open, Showing Relay Panel (Photo C-11526).....	6
1-5	The Type MO Frequency Modulated Oscillator, Top View (Photo C-11547)....	8
1-6	The Type MO Frequency Modulated Oscillator, Bottom View (Photo C-11878)	9
1-7	The Type MO Frequency Modulated Oscillator, Front Panel (Photo C-10768)..	10
1-8	The Type MP Frequency Stabilizer, Top View (Photo C-11546).....	11
1-9	The Type MP Frequency Stabilizer, Bottom View (Photo C-11548).....	12
1-10	The Type MP Frequency Stabilizer, Front Panel (Photo C-10766).....	13
1-11	Crystal Oscillator Type MY for Type MP Frequency Stabilizer (Photo C-11553)	14
1-12	Crystal Oscillator Type MY for Type MP Frequency Stabilizer, Bottom View (Photo C-11552).....	14
1-13	Voltage Regulator DL-7503556, G-1 for Type FM-3 Transmitter (Photo C-11549)	15
1-14	Voltage Regulator DL-7503556, G-1 for Type FM-3 Transmitter, Bottom View (Photo C-11551).....	15
2-1	Controls and Instruments on Control Panel (Photo C-11524).....	18
2-2	Control Panel, Rear View (Photo C-11525).....	20
2-3	Controls on Type MO Frequency Modulated Oscillator (Photo C-10768).....	21
2-4	Controls on Type MP Frequency Stabilizer (Photo C-10766).....	26
2-5	Driver Grid Assembly (Photo C-11550).....	29
2-6	3 Kilowatt Output Coupling Loop Assembly (Photo C-11530).....	31
2-7	3 Kilowatt Grid Capacitor and Choke (Photo C-11556).....	31
2-8	Driver and 3 KW Amplifier Neutralizing Controls (Photo C-11529).....	32
2-9	Transmission Line Voltmeter Assembly (Photo C-11544).....	32
2-10	3 Kilowatt Amplifier Cathode Tank Assembly (Photo C-11554).....	34
2-11	FM-3 Driver Amplifier Plate Tank Assembly (Photo C-11555).....	34
2-12	3 Kilowatt Amplifier Plate Tank Assembly (Photo C-11562).....	35
2-13	Shorting Bar Adjustments, Driver Plate Tank and 3 Kw Cathode Tank for Type FM-3 Transmitter (Curve 329688).....	36

## LIST OF ILLUSTRATIONS (Cont.)

<i>Figure</i>	<i>Title</i>	<i>Location</i>
2-14	3 Kw Plate Tank Shorting Bar and 3 KW Cathode Input Tap Adjustments for Type FM-3 Transmitter (Curve 329687).....	37
3-1	Functional Block Diagram of the Type FM-3 Transmitter (Dwg. 7425887)....	40
3-2	Resistive and Reactive Current in Diode Modulator (Dwg. 7425690).....	44
3-3	Pulse Discriminator, Simplified Schematic Diagram (Dwg. 7425689).....	49
3-4	Waveforms of Frequency Stabilizing Circuits (Dwg. 7425687).....	51
3-5	Pulse Integrator, Simplified Schematic Diagram (Dwg. 7425688).....	53
6-1	The Type FM-3 Broadcast Transmitter, Cubicle Outline and Installation Drawing (Dwg. 7617869).....	Tab 1
6-2	Type FM-3 Cubicle, Schematic Diagram (Dwg. 7301008).....	Tab 2
6-3	Type MO Frequency Modulated Oscillator, Schematic Diagram (Dwg. 7616723) .	Tab 3
6-4	Type MP Frequency Stabilizer, Schematic Diagram (Dwg. 7616233).....	Tab 4
6-5	Style 1352565 Crystal Oscillator Unit, Schematic Diagram (Dwg. 7717114)....	Tab 5
6-6	Type FM-3 Cubicle Wiring Diagram (Dwg. 7301012).....	Tab 6
6-7	Type FM-3 Control Panel Wiring Diagram (Dwg. 7616738).....	Tab 7
6-8	Type MO Frequency Modulated Oscillator, Wiring Diagram (Dwg. 7301007)....	Tab 8
6-9	Type MP Frequency Stabilizer, Wiring Diagram (Dwg. 7616651).....	Tab 9
6-10	Voltage Regulator Chassis DL-7503556, G-1 Wiring Diagram (Dwg. 7616748)....	Tab 10
6-11	Type MY Crystal Oscillator Unit, Wiring Diagram (Dwg. 7717408).....	Tab 11
6-12	3 Kilowatt Transmitter, Schematic Diagram (Dwg. 7616779).....	Tab 12
6-13	Distribution Bus Regulator Connections, FM-3 (Dwg. 7427815).....	Tab 13
6-14	FM-3 Relay Panel, Wiring Diagram (Dwg. 7718382).....	Tab 14

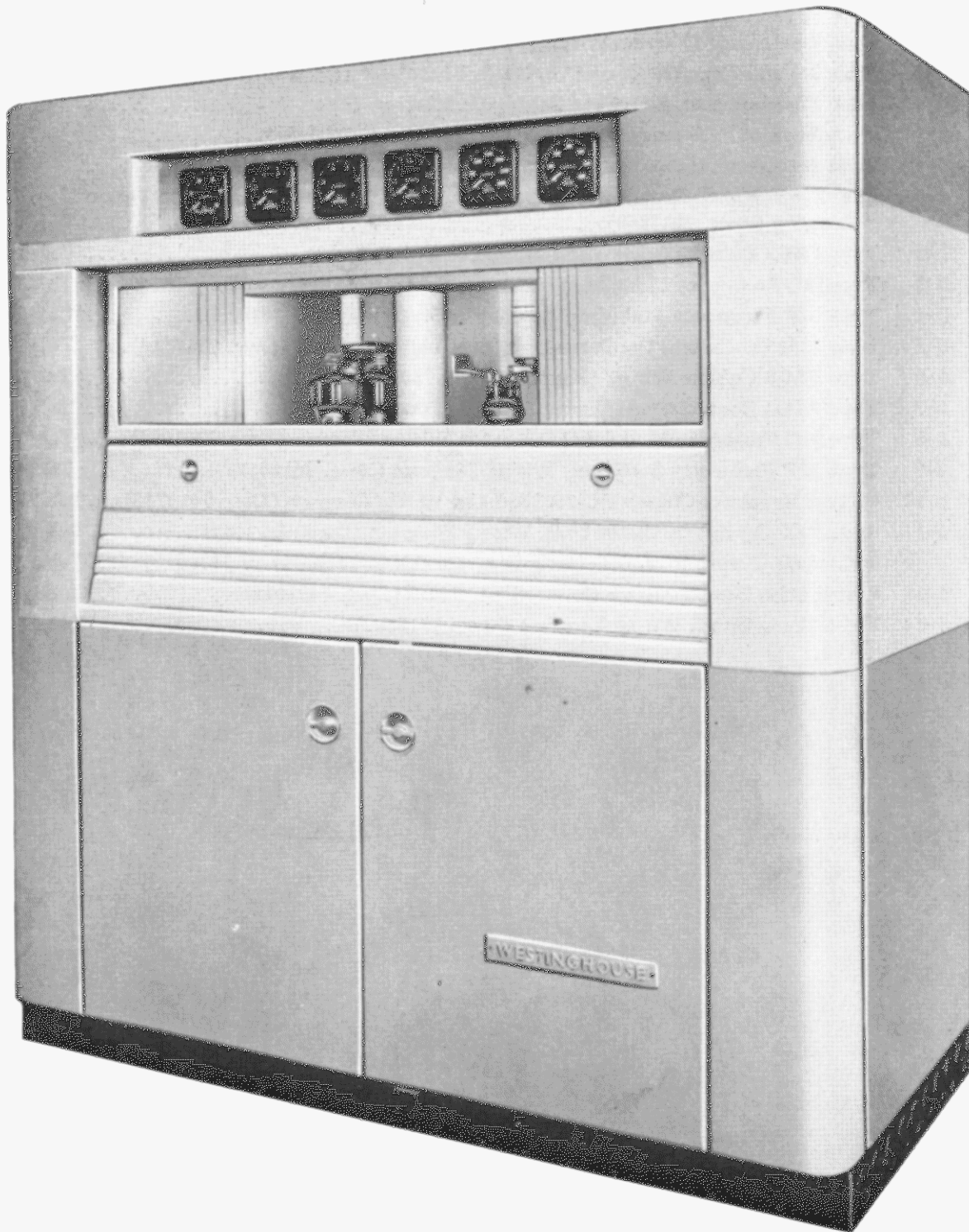

Figure 1-1—Westinghouse Type FM-3 3 Kilowatt Frequency Modulated Broadcast Transmitter



# PART ONE

## INTRODUCTION

The Westinghouse Type FM-3 3 Kilowatt Frequency Modulated Broadcast Transmitter is a single-unit transmitter designed for use as a complete 3 kilowatt broadcast plant, or as an exciter unit for a 10 kilowatt, or even larger installation. It is designed to operate on any single specified carrier frequency from 88 to 108 megacycles per second, with a nominal power output of 3 kilowatts. Its frequency stability is such that, at the maximum modulation capability of  $\pm 100$  kilocycles, the carrier frequency stability is better than  $\pm 1,000$  cycles per second.

Based upon a nominal carrier swing of  $\pm 75$  kilocycles per second, the audio frequency response over a range of 30 to 15,000 cycles, without pre-emphasis, is  $\pm 1$  db from response at 1,000 cycles. With pre-emphasis, the response is  $\pm 1$  db from a 75-microsecond curve. The necessary audio input required for a  $\pm 75$  kilocycle swing is +10 dbm at 400 cycles. An adjustable audio input transformer is provided so that the audio voltages may be supplied by either a 600-ohm balanced line, or a 150-ohm unbalanced line.

The harmonic distortion, including all harmonics up to 30 kilocycles per second at the  $\pm 75$ -kilocycle modulation swing is less than 1.5 per cent rms for all modulating frequencies between 50 and 15,000 cycles per second. The frequency modulation noise level is at least 65 db below the  $\pm 75$  kilocycle swing while the AM noise level is at least 50 db below 100 per cent AM.

The transmitter requires a primary power source of 208/230 volts, 50/60 cycle, 3-phase alternating current capable of delivering 8,500 watts at a 90 per cent power factor. Two additional sources of 115 volts, 50/60 cycle single phase alternating current are also required. One is employed for continuous operation of the crystal heaters and the other for operation of a trouble light and utility outlets within the cubicle.

The output of the transmitter is designed to couple to a 51.5-ohm transmission line in accordance with RMA standards.

Provisions are made for remote operation of the filament, low voltage and high voltage rectifier circuits of the transmitter, if desired. These controls may also be interconnected with the control circuits of a higher powered final amplifier, if the Type FM-3 Transmitter is utilized as an exciter unit in a higher-powered installation.

### Units of the Transmitter

All of the circuits and components of the Type FM-3 Transmitter are contained in a single attrac-

tively styled cubicle that is designed to be installed at the operating position in the transmitter room at the broadcast station. This cubicle, with all of the access doors closed for normal operation, is shown in Fig. 1-1. The row of large supervisory meters along the top of the cubicle are indirectly lighted by fluorescent lamps located in a trough just below them. These meters provide the operator with continuous visual indications of the operating conditions within the transmitter.

Fig. 1-2 shows approximately the same view of the transmitter, with the access doors open, showing the location of the operating, power and tuning controls and certain additional meters that are used when turning the transmitter on and off, tuning it and checking its operation.

Two removable plug-in units are located behind the lower front access doors. These are the Type MO Frequency Modulated Oscillator, in the upper left hand section of this compartment, and the Type MP Frequency Stabilizer in the upper right. These two units contain the frequency-generating, the modulating and frequency stabilizing circuits of the transmitter. Two small plug-in units containing two crystal oscillator circuits that supply the reference frequency for stabilizing the carrier are located in the Type MP Frequency Stabilizer.

### Location of the Components

Most of the components normally requiring attention may be reached from the front of the cubicle. Other components, such as the voltage regulators, the tuning circuits are located within the cubicle, but are motor-driven, and may be controlled from the control panel. Fig. 1-2 shows how the glass windows over the tube compartments are hinged so that they may be quickly opened and the tubes reached from the front of the cubicle. The control panel is also hinged, and may be tilted forward when it is necessary to reach the components directly behind it.

The Type MO and Type MP Units are equipped with self-aligning connectors on the units and within the cubicle. When these units are put into their compartments and pushed back the full distance, the connections are automatically made between their circuits and the circuits in the cubicle. The two units are held in place by four thumb-screws. This construction permits these two units to be removed for inspection and replaced by loosening the thumb-screws. This eliminates the time and delay of disconnecting and reconnecting the usual inter-unit wiring.

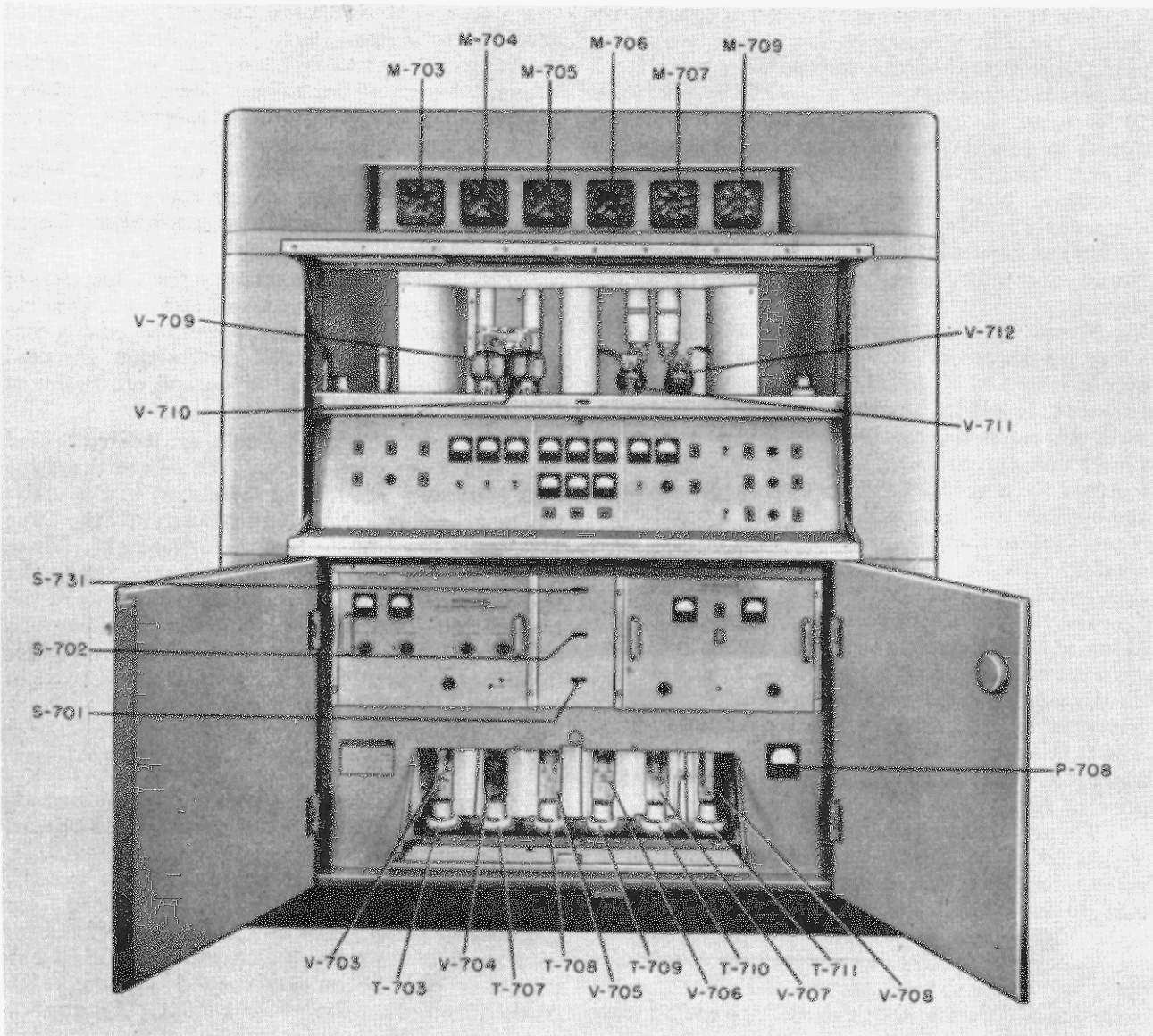

Figure 1-2—Type FM-3 Broadcast Transmitter, Front View, Front Access Doors Open

The row of supervisory meters along the top of the cubicle are mounted in a recess and illuminated by fluorescent lights located in a trough below and immediately in front of them. The large size of these meters, their 270 degree scale and large clear markings and the fluorescent lighting makes it possible for these meters to be read at a considerable distance from the transmitter.

From left to right, these meters are the DRIVER GRID CURRENT, the DRIVER PLATE CURRENT, the 3 KILOWATT AMPLIFIER GRID CURRENT, the 3 KILOWATT AMPLIFIER PLATE CURRENT, the 2500 VOLT RECTIFIER, and the TRANSMISSION LINE VOLTAGE meters. These meters give the operator, at a glance, the critical indications necessary to determine the performance of the transmitter.

Below the row of supervisory meters and behind the large blue glass window, shown raised in Fig. 1-2 are four separate compartments. In the left hand compartment, behind the frosted section of the blue glass, is a small chassis that contains the components of an electronic voltage regulator circuit that supplies regulated power to the Type MO Frequency Modulated Oscillator.

In the compartment just to the right of the voltage regulator are the two Type WL5D22/4-250A Tubes employed in the push-pull driver stage. The plate lines of this stage may be seen extending upward above the tubes. The next compartment contains the two Type WL473 Tubes, with their cathode lines extending upward from the tubes. The compartment at the far right, behind the right hand frosted section of the blue glass window, is equipped with unwired sockets for holding spare driver, amplifier and rectifier tubes so that they may be convenient when required.

The control panel contains the switches, meters, indicator lights and many other components of the control equipment. This panel is shown in its normal position in Fig. 1-2.

The various items on the control panel are identified, in the following description, by their nameplate designations. In most instances, these designations will serve to identify their functions. A more complete description of their operation will be given in Part Two, Installation and Adjustment, of this instruction book.

In the left-hand section of the control panel are five red indicator lights grouped around a push-button. These indicator lights are the supervisory indicator lights employed in the control circuits. When an overload occurs in any stage of the transmitter, the overload protective relay opens and removes the transmitter from the air. However, when the overload is cleared, the transmitter will then come back on. This action may be so fast that the

operator will not have time to observe in which circuit the overload occurs. However, when the overload relay operates, it will light the light in this group associated with it and this light will remain on until the push-button is released, even though the transmitter is again operating normally when the operator reaches it.

These supervisory indicator lights are the 400 VOLT RECTIFIER OVERLOAD, the DRIVER OVERLOAD, the LEFT 3 KW AMPLIFIER OVERLOAD, the 2500 VOLT RECTIFIER OVERLOAD and the RIGHT 3 KW AMPLIFIER OVERLOAD indicator lights. The push-button used to reset the supervisory circuits is the OVERLOAD INDICATOR RESET button, located in the center of the lights.

To the right of the supervisory indicator lights, in the left hand section of the control panel, are three meters used to indicate the conditions of the tuned circuits in the cubicle. Just below each meter is a telephone type switch used to operate the tuning mechanism associated with the tuned circuits. These three pairs of meters and switches are the DRIVER GRID TUNING, the DRIVER PLATE TUNING and the 3 KW AMPLIFIER tuning indicators and switches.

In the small center panel are six meters and three indicator lights. The meters in the top row are, from left to right, the MODULATED OSCILLATOR PLATE CURRENT, the TRIPLER PLATE CURRENT and the INTERMEDIATE AMPLIFIER PLATE CURRENT meters. The second row contains the MODULATOR PLATE CURRENT, the TRIPLER GRID CURRENT and the INTERMEDIATE AMPLIFIER GRID CURRENT meters. All of these meters indicate operating conditions in the Type MO Modulated Oscillator Unit.

Below the meters in the center section of the control panel are three indicator lights. From left to right, these are the CRYSTAL HEATER POWER, the CRYSTAL HEATER NO. 1 and the CRYSTAL HEATER NO. 2 indicator lights, that indicate the operation of the crystal oscillator units in the Type MP Frequency Stabilizer unit.

In the right hand section of the control panel is the 3 KW AMPLIFIER OUTPUT COUPLING indicating meter and below it is the switch that operates the motor-driven output coupling mechanism. To the right is the BUS VOLTAGE meter and directly below it is a 5-position rotary switch that connects this meter to the various points in the a-c supply lines to permit the operator to secure indications of the voltage in the a-c distribution system.

The DOOR INTERLOCK and AIR INTERLOCK indicator lights are located one over the

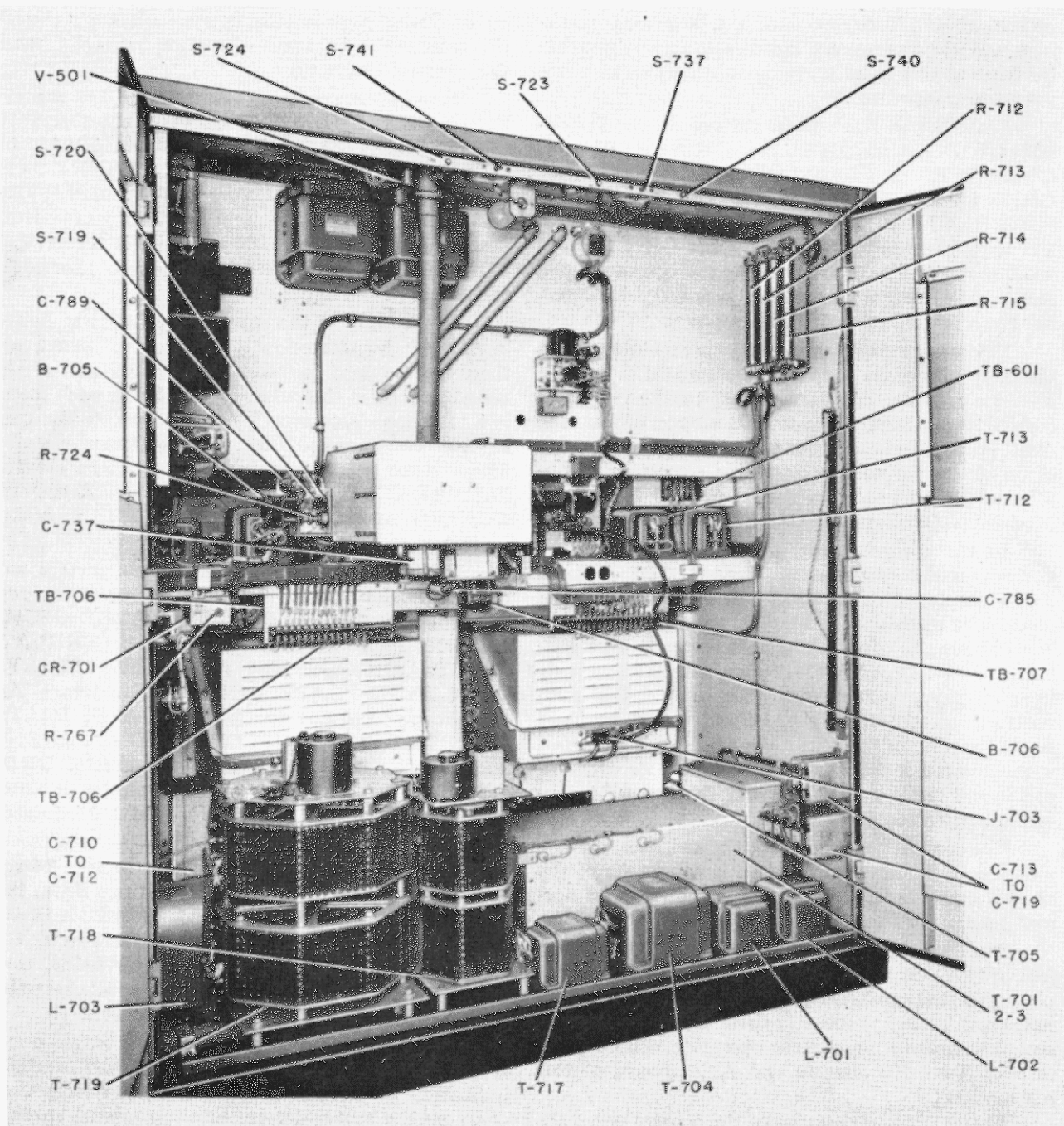

Figure 1-3—Type FM-3 Broadcast Transmitter, Rear View, Access Doors Open

other to the right of the BUS VOLTAGE meter and switch. To the right of them are the DISTRIBUTION BUS REGULATOR switch (top) and the 2500 VOLT RECTIFIER REGULATOR switch (below) used to control the motor-driven voltage regulators controlling the distribution bus and the 2500 volt rectifier supply voltages.

Three control switches are located, one above the other, on the right of the control panel. Associated with each of these switches is a green READY indicator light on its left and a red ON indicator light on its right. The top switch is the FILAMENT POWER switch, while below are the 400 VOLT RECTIFIER and the 2500 VOLT RECTIFIER switches in the order given.

In the center of the compartment behind the lower access doors are three switches. These are the main circuit breakers used to apply line power to the transmitter. They are the CRYSTAL HEATER POWER breaker, the AUXILIARY BUS POWER breaker and the 2500 VOLT RECTIFIER POWER breaker. Below them is the TUBE HOUR meter that indicates the total time the tubes are turned on.

A number of tuning controls and two meters are located on the front panel of the Type MO Modulated Oscillator unit in the upper left hand section of the compartment behind the lower front access doors. The two meters on the front panel are the DISCRIMINATOR CURRENT, TOTAL (left) and the DIFFERENTIAL (right) meters used in aligning the feedback discriminator in the audio section of the unit. Below the meters, in a row extending horizontally across the front panel are the tuning controls for the radio frequency stages.

Each of these controls consists of a COARSE screwdriver adjustment and a FINE knob-operated control. From left to right, these controls are the OSCILLATOR GRID TUNING, the TRIPLER GRID TUNING, the TRIPLER PLATE TUNING and the AMPLIFIER PLATE TUNING controls.

Below the row of tuning controls on the Type MO unit, near the center of the panel, is the PRE-EMPHASIS switch that has two positions, ON and OFF. To the right of the PRE-EMPHASIS switch are two screwdriver adjustments. These are the DISCRIMINATOR TUNING, PRIMARY and SECONDARY controls.

Two meters, the MIXER GRID CURRENT and the CRYSTAL OSCILLATOR CATHODE CURRENT meters, are located on the front panel of the Type MP Frequency Stabilizer unit. Between them are two indicator lights. The top indicator is the FREQUENCY CONTROL ON light that shows when the control circuits are turned on and the BEAT INDICATOR light indicates their proper functioning.

Three controls form a row along the bottom of the panel. These are the CRYSTAL INDICATOR,

1 and 2 switch, the DIODE BIAS control and the FREQUENCY CONTROL switch.

Below the Type MO and Type MP units, behind the long glass window, are, from left to right, the two Type 866A Tubes for the 400-volt rectifier and the six Type 872A Tubes for the 2500-volt rectifier. The filament transformers for the 872A Tubes are visible just below the tube socket.

Figure 1-3 shows the transmitter with the rear access doors open. The heavy coaxial cable running towards the top of the cubicle near the rear center is the output transmission line from the power amplifier plate tank circuit. Near the top of the line is a small panel holding the r-f transmission line voltmeter capacity divider, the voltmeter rectifier tube and the meter multiplier resistor for the TRANSMISSION LINE VOLTAGE meter located in the row of supervisory meters at the top front of the cubicle. The output coupling connector for the transmitter is shown projecting over the top of the cubicle near the rear center.

The circular air-intake ports supplying air to the blower motor may be seen in the black metal base just above the floor level. The air outlet is through a screen at the top cubicle. This outlet is not, however, shown in the figure.

In the upper left hand corner of the cubicle, shown against the left hand side-wall in Fig. 1-4 is a panel containing the main control and supervisory overload and underload relays employed in the control circuits of the transmitter. This panel is hinged along the rear vertical edge of the sidewall and may be swung back for inspection and maintenance.

Directly below the relay panel and mounted against the side wall are four contactors. These are, from the rear, the 400-volt rectifier contactor, the filament contactor, the 2500-volt rectifier step-start contactor and the 2500-volt rectifier contactor.

Below the row of contactors, and towards the front of the cubicle are three large resistors that are employed in the step-start circuits to withhold full power from the 2500-volt rectifier primaries for a fraction of a second while the filter capacitors charge.

Behind these resistors, mounted horizontally, are two terminal boards and below these, mounted vertically are the two main terminal boards to which the line power and the audio input to the transmitter is connected.

On the shelf running horizontally across the cubicle just above the center are, on the left hand side, the crystal heater transformer and the transformer that supplies power to two Rectox units that are used in the tuning motor and indicating circuits. Below these transformers, mounted below the shelf, are two Rectox rectifier units also employed in the motor-driven tuning circuits.

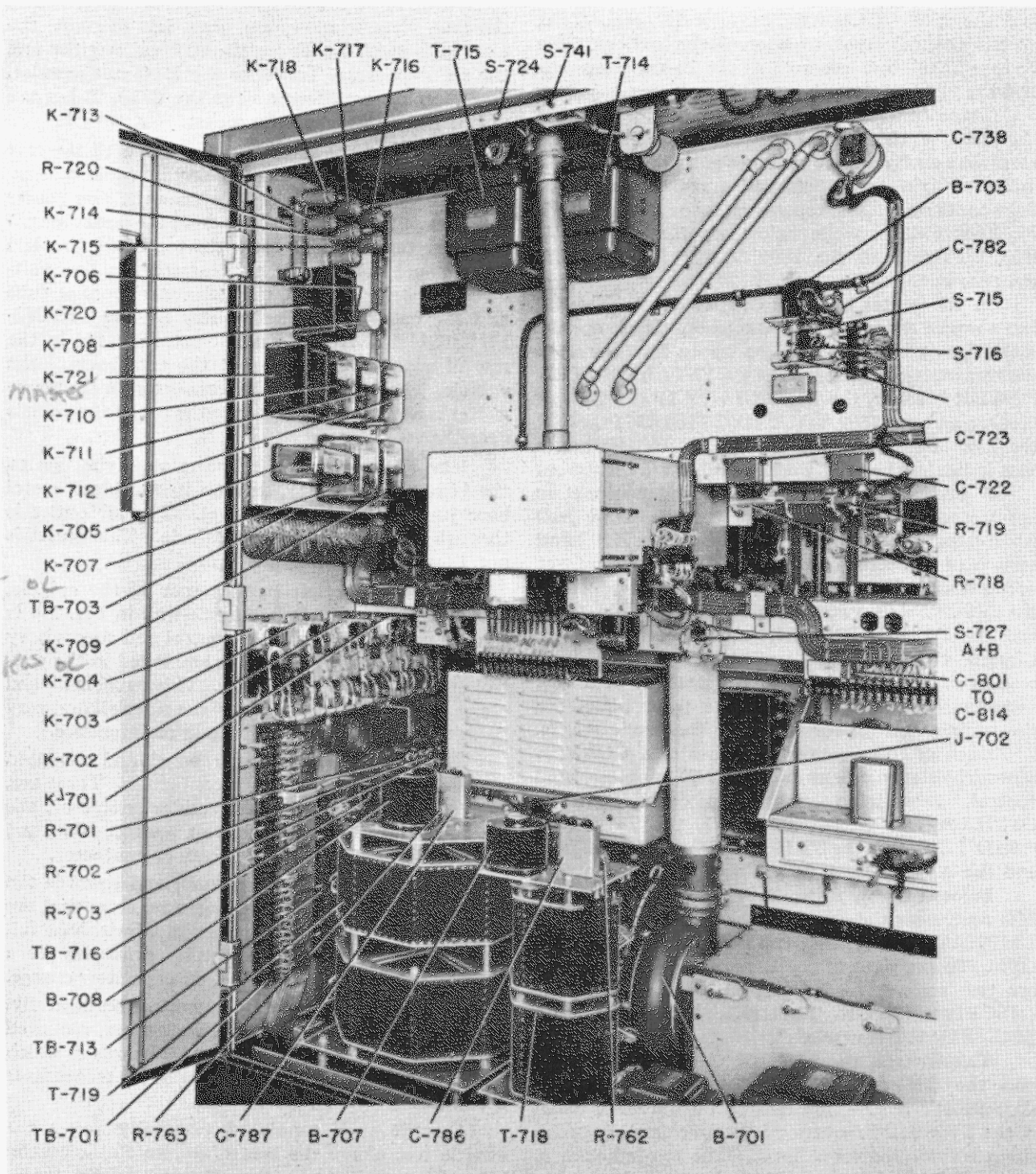

Figure 1-4—Type FM-3 Broadcast Transmitter, Rear View, Access Doors Open, Showing Relay Panel

Towards the center of the cubicle from these two transformers, and slightly larger, is a rectangular aluminum compartment that contains the 3 kilowatt amplifier tank and output coupling components. The motor drives for these can be seen located around the compartment.

Directly above and mounted to the top of the cubicle are the two Scott-connected filament transformers for the 3 kilowatt amplifier. To the right of the amplifier plate tank can be seen the grid tank circuit for the driver stage, with its tuning motors and associated components nearby. To the right of the driver grid tank are the two Scott-connected transformers that supply filament power for the driver stage. Along the rear edge of the shelf just to the left of the filament transformers are two convenience outlets provided for operating soldering irons and test equipment when servicing the transmitter. These two outlets are supplied 110-volt power from an independent source and therefore may be used when the 3-phase power supply to the transmitter is cut off.

The shields for the Type MO and Type MP units can be seen on either side of the center of the front wall of the cubicle just below the tube shelf. The vertical duct rising between them carries the cooling air from the blower motor to the driver and 3 kilowatt amplifier tubes.

On the left hand wall of the cubicle, near the top, are a group of resistors employed in the driver screen circuit. On the side-wall near the bottom are a number of capacitors used in the filter for the 400-volt rectifier.

The components on the floor of the cubicle consist, mainly, of the components of the 400-volt and 2500-volt rectifier circuits. In the left hand front corner (not easily seen in Fig. 1-4) are the filter capacitors for the 2500-volt rectifier while behind them is the 2500-volt rectifier filter inductor. Towards the rear of the cubicle on the left hand side is the 2500-volt rectifier voltage regulator. To the right of the 2500-volt rectifier regulator is the motor-driven regulator for the distribution bus supply. In front of this regulator is the blower motor, its filter and air ducts.

The 6.3-volt filament transformer, the 400-volt rectifier power transformer and the two 400-volt rectifier filter inductances form a row across the back of the cubicle floor, while the 2500-volt rectifier power transformer is in the intake air duct. The filament transformer for the 866A Tubes in the 400-

volt rectifier is located in the right front corner of the cubicle floor, practically alongside of the rectifier tubes.

### Vacuum Tubes Required

The following complement of vacuum tubes is required for operation of the transmitter. The manufacturer recommends that a representative number of each type be maintained on hand at all times as spares for replacement when necessary.

<i>Tube Type Number</i>	<i>Circuit Symbol No.</i>	<i>Function of the Tubes</i>
<b>(TYPE MO FREQUENCY MODULATED OSCILLATOR)</b>		
6SJ7	V-201	Audio Amplifier
1614	V-202	Modulator Control Tube
6H6	V-203	Diode Modulator
6H6	V-204	Audio Feedback Discriminator
1614	V-205	Frequency Modulated Oscillator-Tripler
829B	V-206	R-F Tripler
829B	V-207	R-F Intermediate Amplifier
<b>(TYPE MP FREQUENCY STABILIZER)</b>		
6SJ7	V-301	Buffer Amplifier
6SA7	V-302	#1 Mixer
6SN7	V-303	Amplifier
6SN7	V-304	Pulse Generator
6SA7	V-307	#2 Mixer
6H6	V-308	Pulse Discriminator
6SL7	V-309	Pulse Amplifier
6H6	V-310	Pulse Limiter
6H6	V-311	Pulse Integrator
	V-312	
6SL7	V-313	Cathode Follower
6X5GT/G	V-314	Bias Rectifier
OC3/VR105	V-315	Bias Voltage Regulator
OD3/VR150	V-316	Voltage Regulator
OC3/VR105	V-317	Voltage Regulator
1614	V-401	Crystal Oscillator #1
1614	V-401	Crystal Oscillator #2
<b>(TUBES IN FM-3 CUBICLE CIRCUITS)</b>		
9006	V-501	R-F Voltmeter Rectifier
6Y6G	V-601	Voltage Regulator Tubes
6Y6G	V-602	
6SJ7	V-603	Regulator Control Tube
OC3/VR105	V-604	Regulator Bias Tube
866A	V-701	400-Volt Rectifier Tubes
866A	V-702	
872A	V-703	2500-Volt Rectifier Tubes
872A	V-704	
872A	V-705	
872A	V-706	
872A	V-707	
872A	V-708	
4-250A	V-709	R-F Driver Tubes
4-250A	V-710	
473	V-711	3 Kilowatt Amplifier Tubes
473	V-712	

*Note:* Two Westinghouse Rectox Metal Rectifiers are also employed in the transmitter. These components have almost unlimited life and will not require replacement unless subject to mechanical damage.

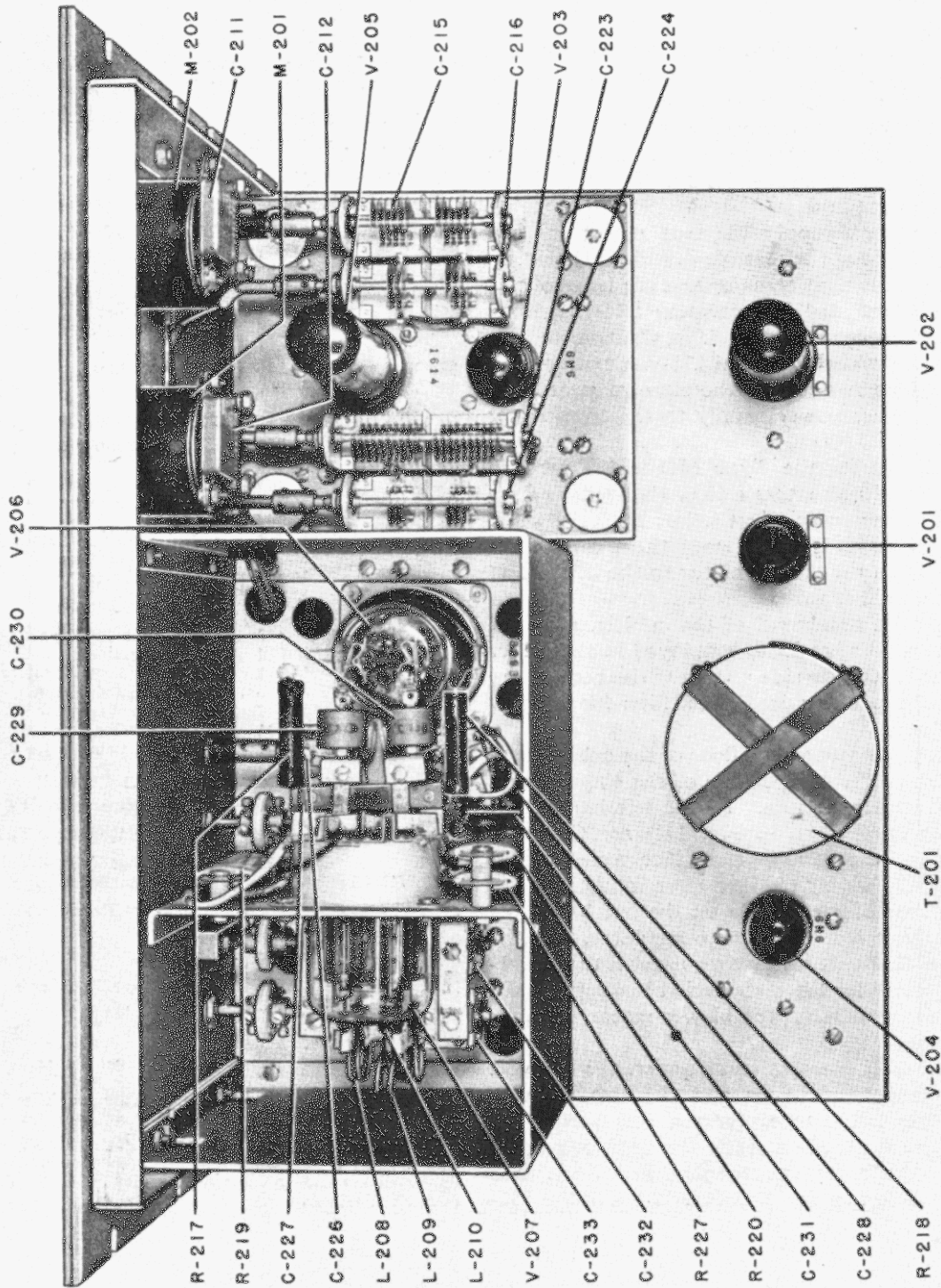

Figure 1-5—Type MO Frequency Modulated Oscillator, Top View



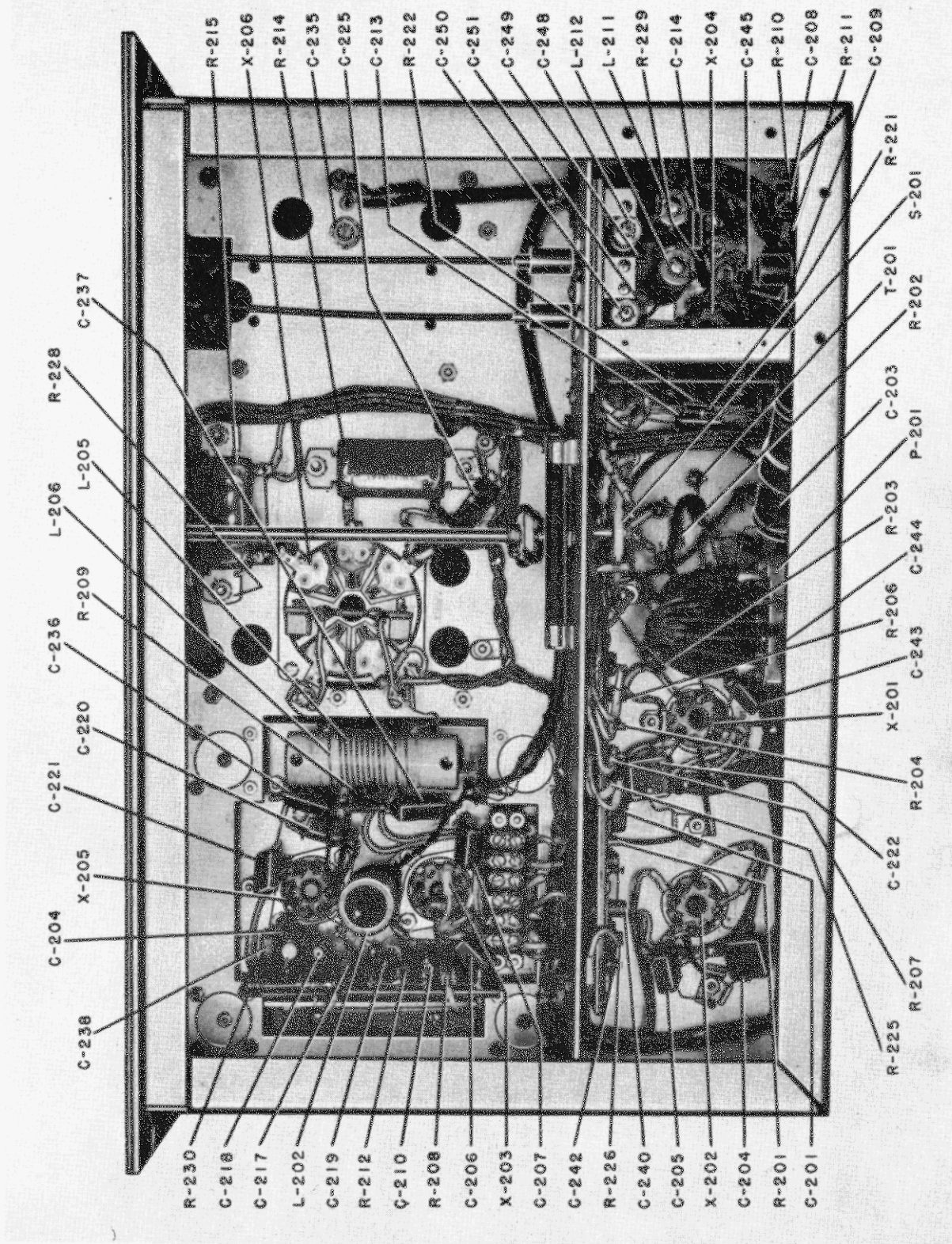

Figure 1-6—Type MO Frequency Modulated Oscillator, Bottom View

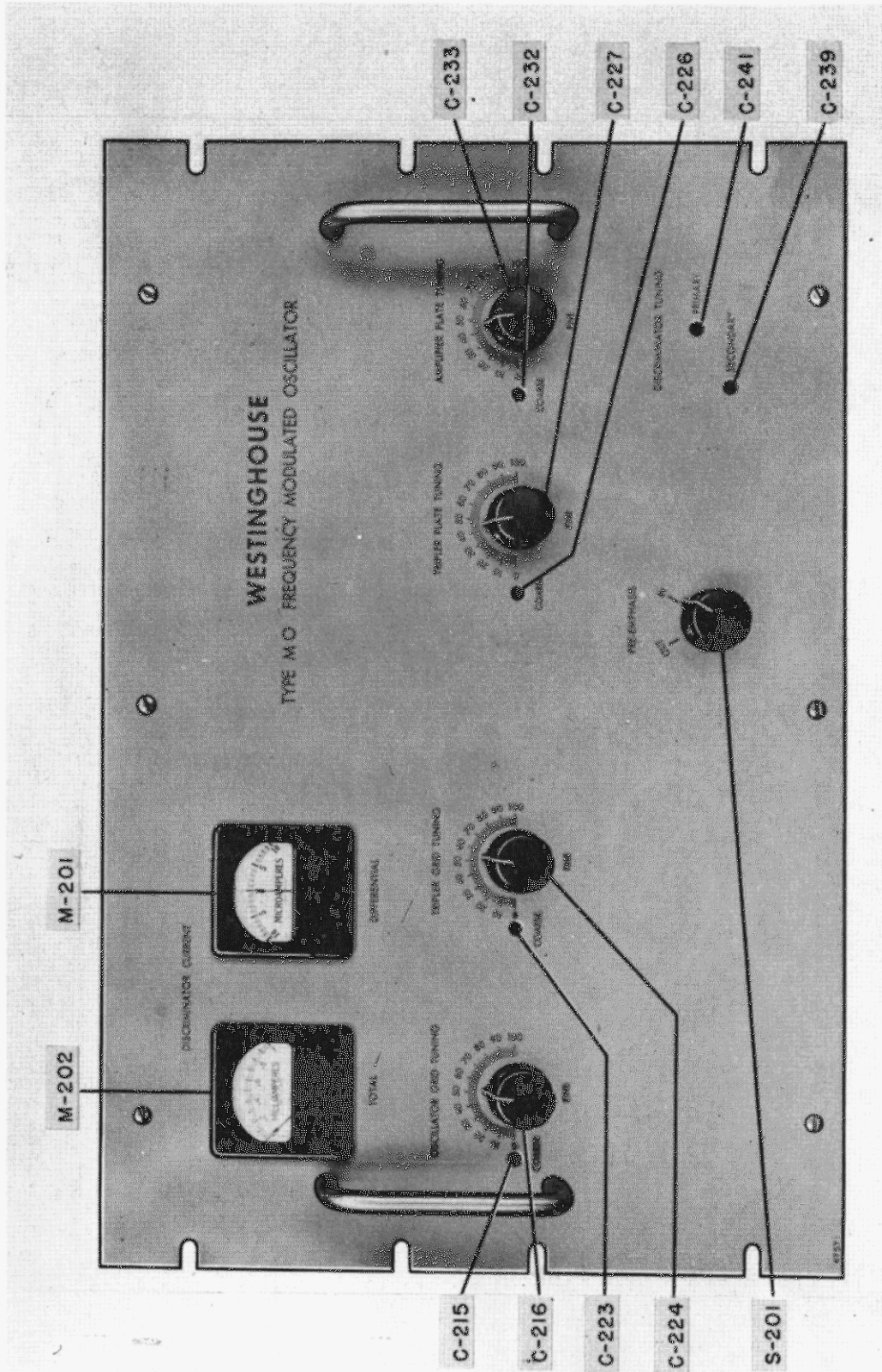

Figure 1-7—Type MO Frequency Modulated Oscillator, Front Panel

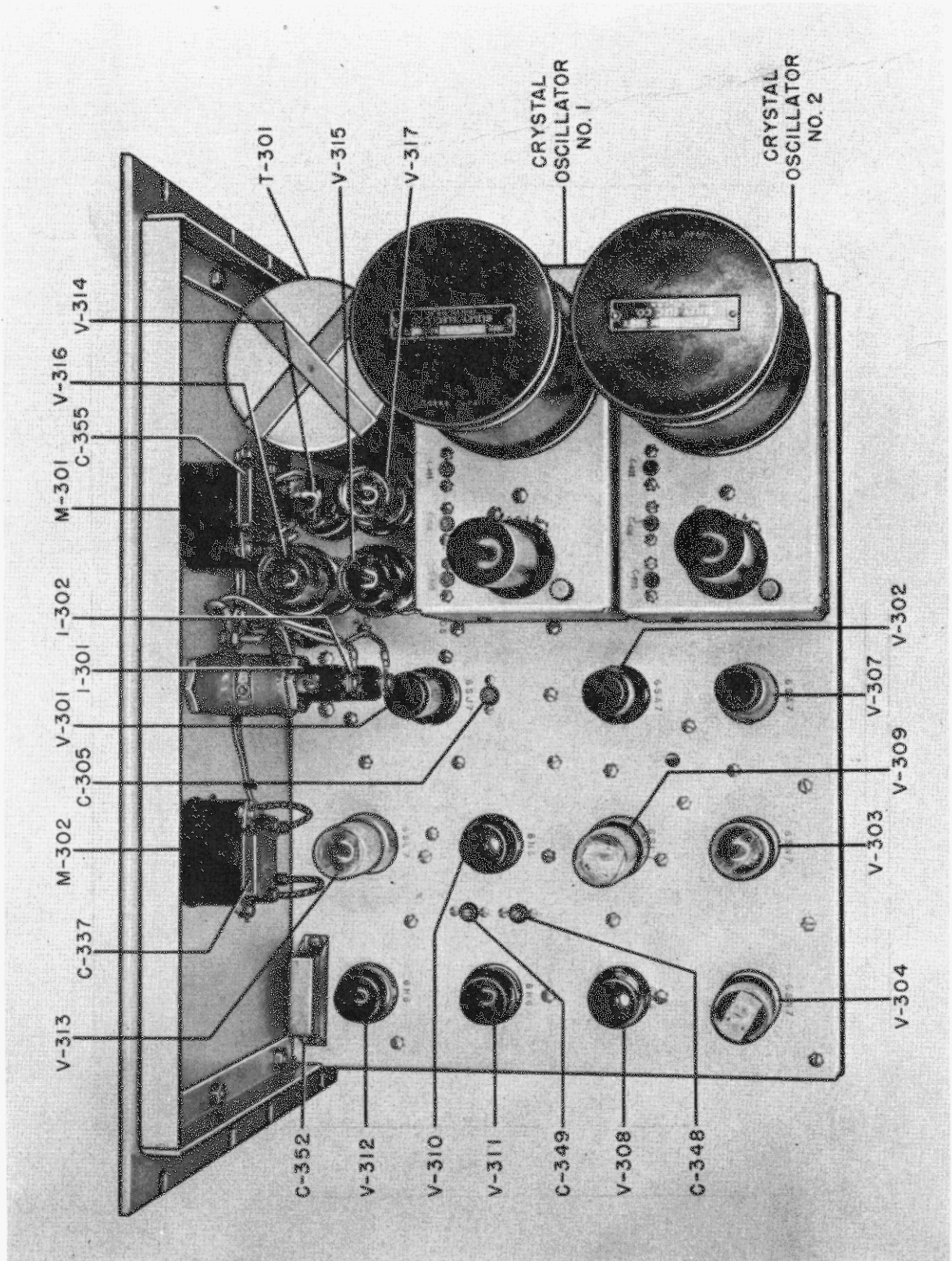

Figure 1-8—Type MP Frequency Stabilizer, Top View

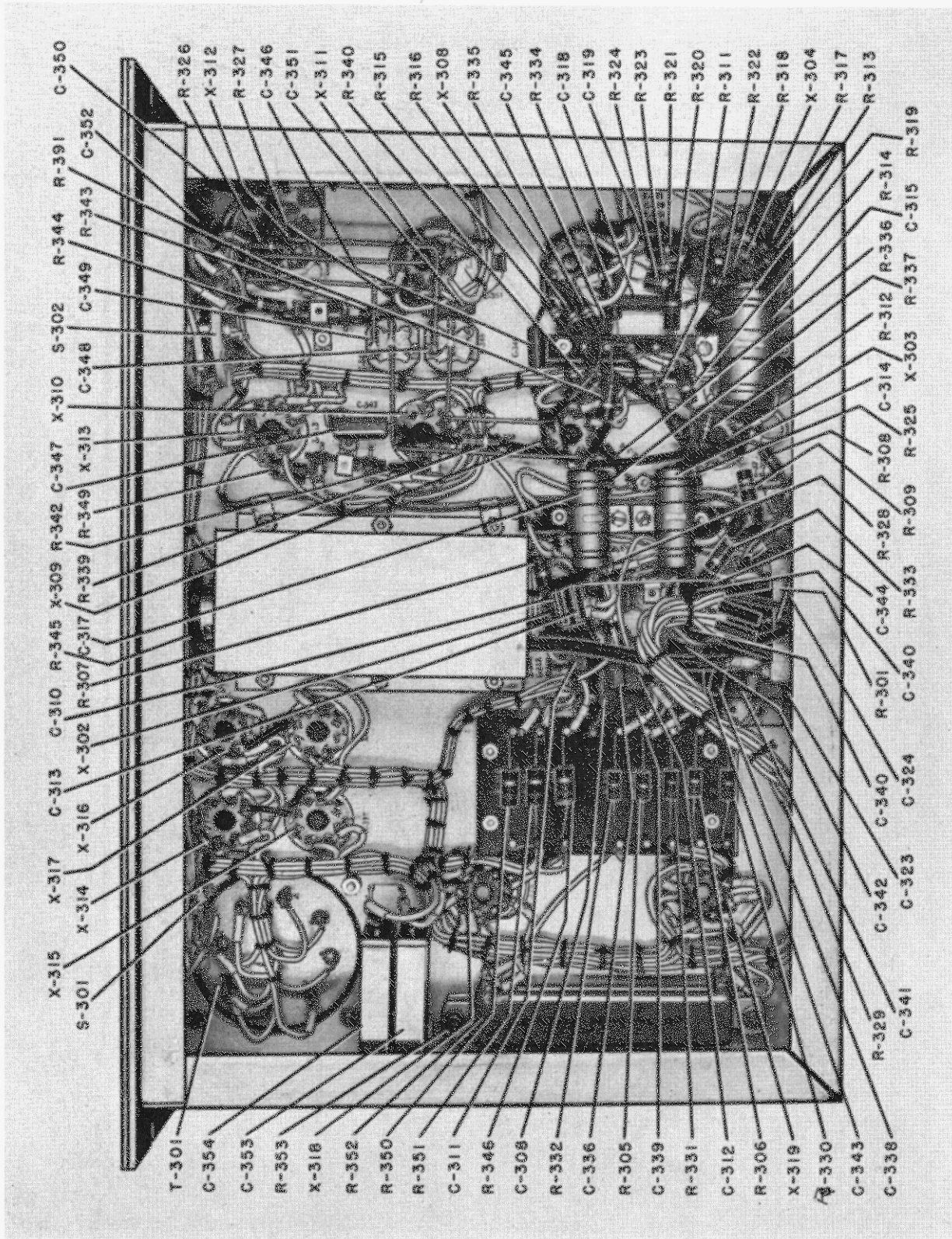

Figure 1-9—Type MP Frequency Stabilizer, Bottom View

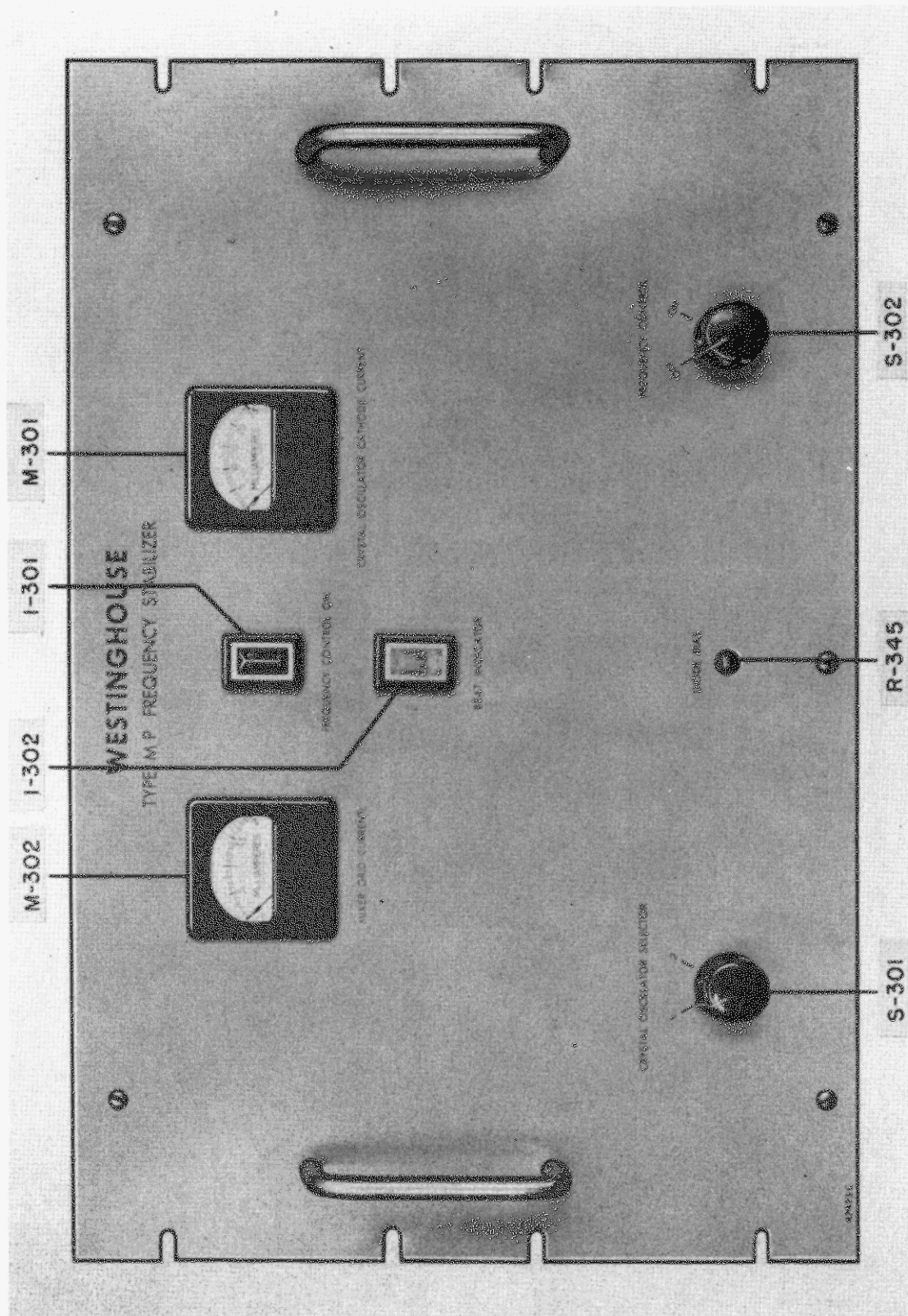

Figure 1-10—Type MP Frequency Stabilizer, Front Panel

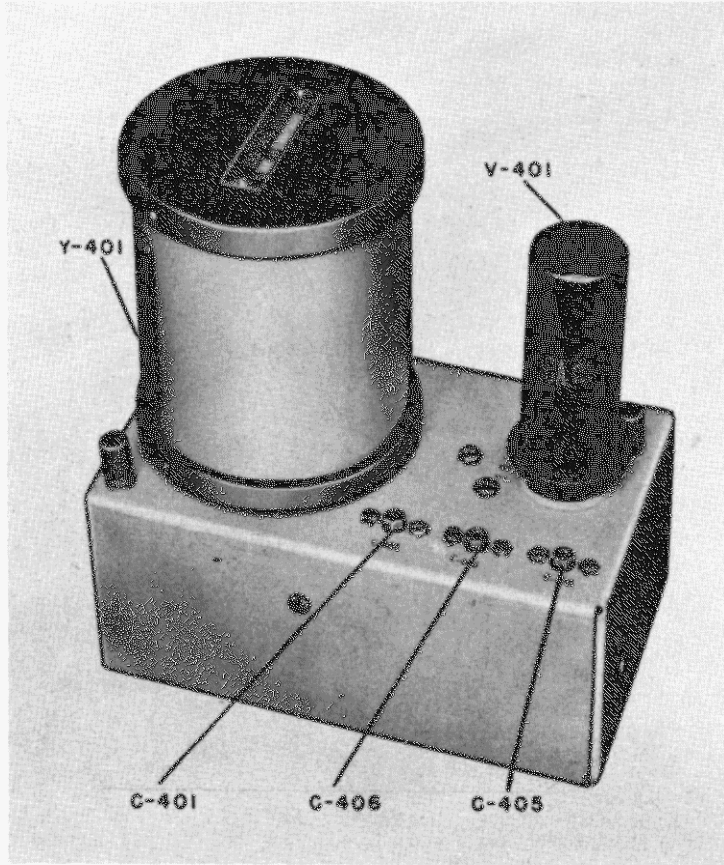

Figure 1-11—Crystal Oscillator Type MY for Type MP Frequency Stabilizer

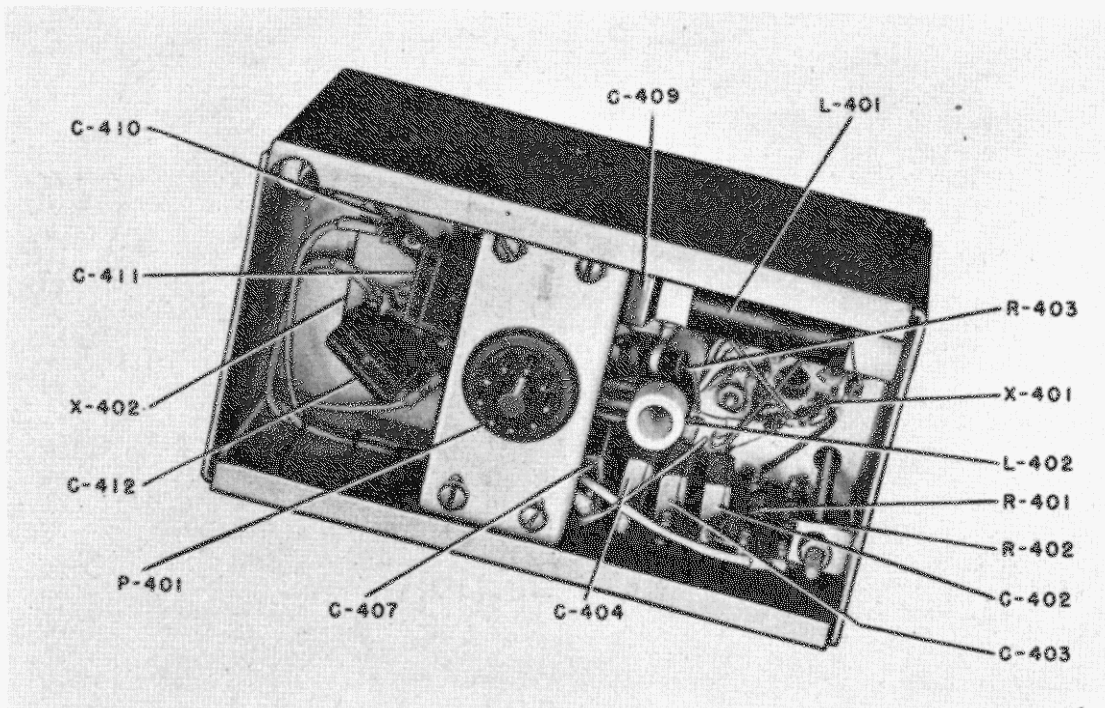

Figure 1-12—Crystal Oscillator Type MY for Type MP Frequency Stabilizer, Bottom View

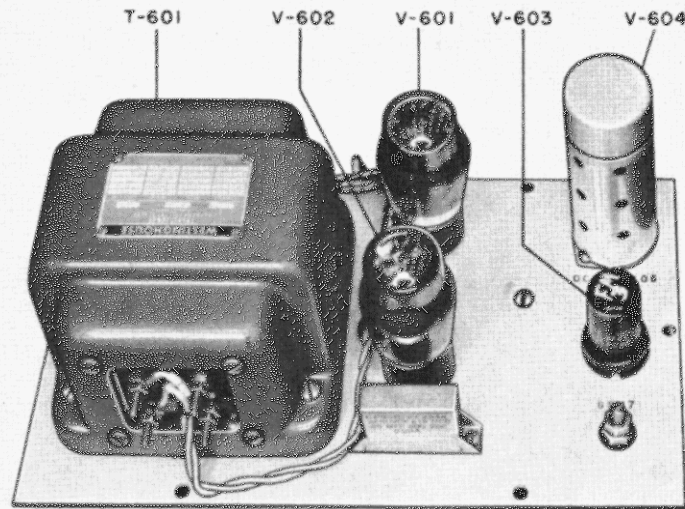

Figure 1-13—Voltage Regulator DL-7503556, G-1 for Type FM-3 Transmitter

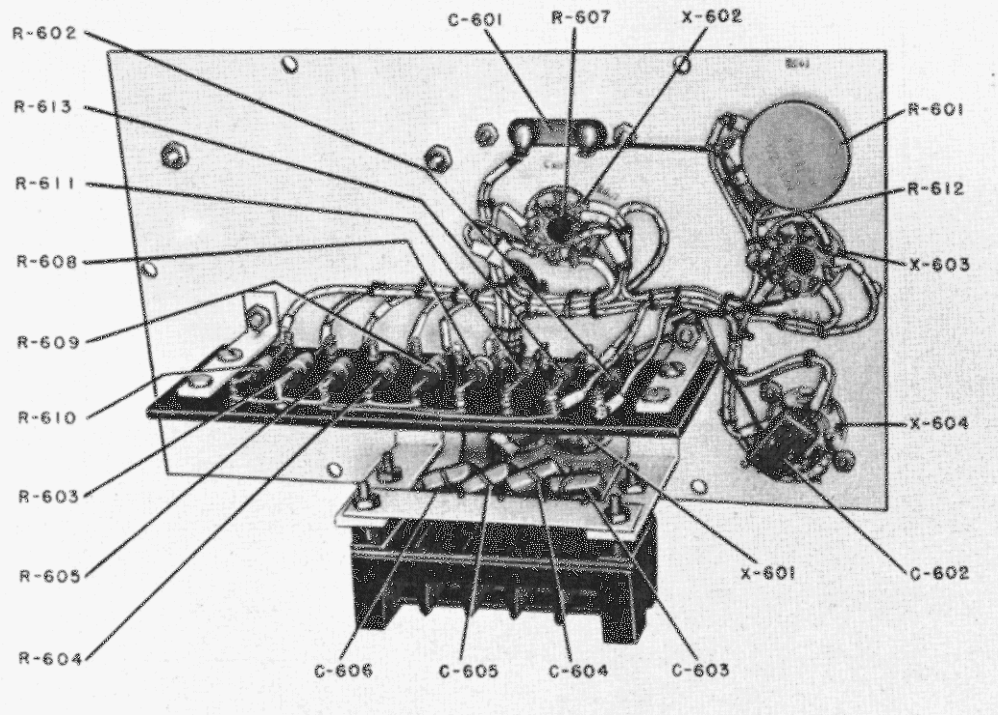

Figure 1-14—Voltage Regulator DL-7503556, G-1 for Type FM-3 Transmitter, Bottom View

## PART TWO

# INSTALLATION, ADJUSTMENT AND OPERATION

The Type FM-3 Frequency Modulated Broadcast Transmitter is generally installed in the transmitter room at the broadcast station. If the transmitter is being employed as an exciter for a higher-powered installation, it will probably be installed in conjunction with the higher-powered stages of the equipment. The exact location, in any case, will generally depend upon the type of building in which the installation is to be made, the location of the power inlets, the antenna connections, the presence of other equipment and the operating practices of the station. *NOTE:* If increase in power is contemplated, the FM-10 installation Dwg. 7619112 should be consulted and plans made accordingly at time of installation of FM-3.

A location should be chosen, however, where the front panel of the cubicle is visible from the operating console or the monitoring position. If remote controls are used, the front of the cubicles containing the meters, should of course, be visible from the location of the remote controls. The large sizes of the meters in the FM-3 Transmitter, together with the indirect fluorescent lighting that illuminates them, will permit the transmitter to be located at some distance from the operating position and still permit the meters to be easily read.

### Space Requirements for the Installation

The dimensions of the transmitter are shown on the installation and outline drawing, Fig. 6-1. The actual floor-space area required by the cubicle is 34 by 66 inches. However, additional space must be provided so that the cubicle access doors may be opened. The rear doors will require at least 30 inches to open fully while the doors on the front of the cubicle require approximately 24 inches. The total floor area required will, therefore, be approximately 66 inches in width by 88 inches in depth, plus the amount of space required by the operators to work on the transmitter with the doors open.

The cubicle proper is 74 inches high, including the base. Twelve inches should be allowed between the top of the cubicle and the ceiling of the room to permit the air exhaust, located on the top of the transmitter cubicle, to function properly. Also, since the radio frequency output coupling is located on the top of the cubicle, sufficient space must be allowed to permit the proper bending radius of the coaxial lines to the antenna if the line is to be curved within the transmitter room. This space will, of course, be determined by the type of line employed and by the coupling connectors supplied with the antenna and transmission line.

Since the air intake for the blower motor is through the circular apertures located in the back of the transmitter base only a few inches above the floor, at least twelve inches of clear space should always be maintained along the floor back of the cubicle. Provisions should also be made for keeping the floor clean of dust and debris near the intakes.

### Installing the Transmitter Cubicle

The transmitter cubicle weighs approximately 1,900 pounds when uncrated, and approximately 2,200 pounds as crated for shipment. There will be a slight difference in the method of packing depending upon whether the shipment is to be made by railroad freight or by truck. In either case, however, the transmitter will be packed on skids to permit it to be moved on rollers. Sufficient man-power and lifting and moving equipment should be available to handle the equipment without danger of dropping or warping the transmitter when moving it into position during installation.

The manufacturer recommends that the transmitter be moved to a position near its permanent location before it is uncrated in order to eliminate possible damage during handling.

Four  $\frac{5}{8}$ -inch bolts on  $30\frac{1}{4}$  x  $50\frac{7}{8}$  inch centers should be leaded or cemented to the floor at the transmitter location as shown in Fig. 6-1. If through-bolts are used, four holes  $\frac{3}{4}$ -inch in diameter should be drilled through the floor instead. Two holes for 2-inch conduit should be also drilled through the floor. One of these conduits will carry the 230-volt line power and the 115-volt power and the other will carry the RG-8/U monitoring cable, the audio input cable and the remote control cables. The location of these holes are shown on Fig. 6-1.

After the holes in the floor have been drilled, the crated transmitter should be rolled into position in the approximate position in which it is to be installed. The crating should be removed, leaving the transmitter on the skids. The transmitter may then be hoisted by the lifting rings on the top of the cubicle, the skids removed, and then lowered into position. If hoisting gear is not available, the transmitter may be lifted from the skids using four jacks, and then lowered into position over the bolts after the skids have been removed.

Since the base of the cubicle forms the air intake for the transmitter, it should be sealed to the floor before being finally bolted into position. Laykold Floor Mastic, G-12 Specification, available from American Bitumuls Co., Baltimore 3, Maryland, is recommended as a sealing and caulking compound,



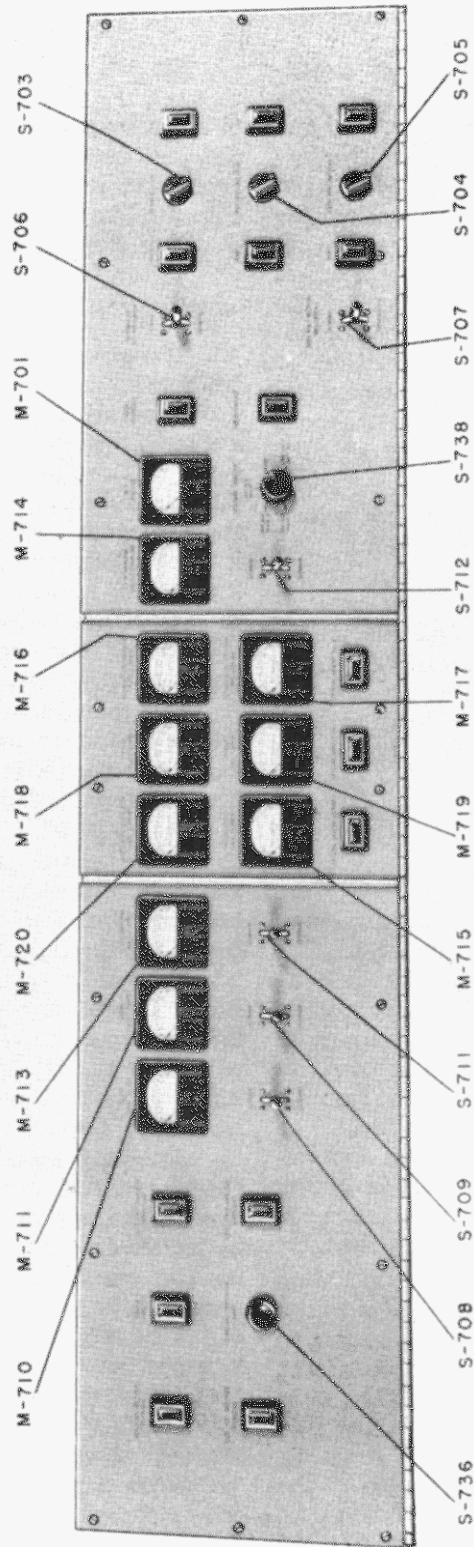

Figure 2-1—Controls and Instruments on Control Panel

although any similar permanent sealing or caulking compound will give the desired results if properly installed.

Install the conduit through the floor as shown in Fig. 6-1 and seal around the conduit with the caulking compound. Install the wires in the conduit, allowing sufficient free length above the floor to reach terminal boards TB-701 and TB-713. If remote control is to be used, these wires, too, should be installed in one of the conduits, and length allowed for connection to TB-713.

With the wires and conduit in place, bolt the transmitter firmly to the floor. Make certain that all possible air leaks around the base have been filled with the sealing compound. If the floor is not level, it will be necessary to shim up the transmitter before tightening the bolts so as to prevent warping the cubicle base when they are tightened. The sealing compound should again be inspected after it has had time to set so as to make certain that it has not pulled away from the floor or base and thus developed an air leak.

#### Installing the Plug-In Units

The two crates containing the Type MO Frequency Modulated Oscillator and the Type MP Frequency Stabilizer should next be unpacked. Two small cartons containing the two crystal oscillator units for the Type MP Frequency Stabilizer will be found packed with that unit. A cable containing male and female plugs to match the plugs and connectors on the backs of the plug-in units with the corresponding connectors in the cubicle will be found packed with the tubes for the transmitter.

This cable is used to connect either of the units to the cubicle after the Unit is removed from its compartment in the cubicle so that the circuits may be circuit-checked during maintenance and troubleshooting operations.

Carefully remove all dust and particles of packing material from the two units. A jet of *dry* compressed air will be of great assistance in removing foreign matter.

Unpack the crystal oscillators and install them in the two sockets provided on the left hand side of the Type MP Frequency Stabilizer chassis. The crystal oscillators should be turned until the plugs on the bottoms of the units fit the plugs on the Type MP chassis. They should then be pushed firmly into place, and secured there by tightening the two captive thumbscrews located on diagonally opposite corners of the crystal oscillator units.

Clean all packing dust and dirt from the two shielded compartments behind the lower access doors in the front of the cubicle. If the tubes are not installed in the Type MO and Type MP units when shipped, unpack the carton of tubes and install

tubes in all of the sockets of the two units. The proper tube type number will be found stamped alongside each socket. When installing the Type 829B Tubes, note that one of the prongs on the bottom of each tube is larger than the rest. This will serve to locate the tube properly in the socket.

If the tubes were installed before shipment, check each tube to make certain that it is seated properly in its socket, and also make certain that the proper type tube is inserted in each socket.

Place the Type MO Frequency Modulated Oscillator in the left hand shielded compartment behind the lower front access doors of the cubicle. Push it back firmly until the front panel of the unit comes back against the front wall of the compartment. Secure it firmly in position with the four thumb-screws that will be found in the small bag attached to the unit. Install the Type MP Frequency Stabilizer in the right hand shielded compartment in the same manner.

**WARNING: DO NOT FORCE THE UNITS BACK INTO POSITION.** If they resist being pushed all the way back, inspect the plugs and connectors for the presence of foreign material, or for a bent plug or connector.

#### Removing Packing Material Inside Cubicle

Check the inside of the cubicle and remove all packing material used to cover and brace the various components. Various of the heavier components within the cubicle will be found to be blocked or braced to prevent undue strain on the cubicle due to rough handling while in shipment. Remove all such material and clean out all packing dust and dirt from the cubicle. A dry jet of compressed air will be found very helpful in removing dust and particles of packing material from hard-to-reach places. Free the shock-mounts on the blower that have been blocked.

#### Unblocking Relays and Contactors

The relays and contactors in the transmitter have been blocked to prevent vibration during shipment. Remove these blocks from all relays and contactors, operating each by hand to make certain that it operates freely.

#### Connections to the Transmitter

When the transmitter has been bolted down, the wires coming through the floor should project up into the cubicle through apertures near the large voltage regulator in the left rear corner of the cubicle, when looking in through the rear access doors. These wires should not be connected to the power sources until after they have been connected to their terminal points within the transmitter.



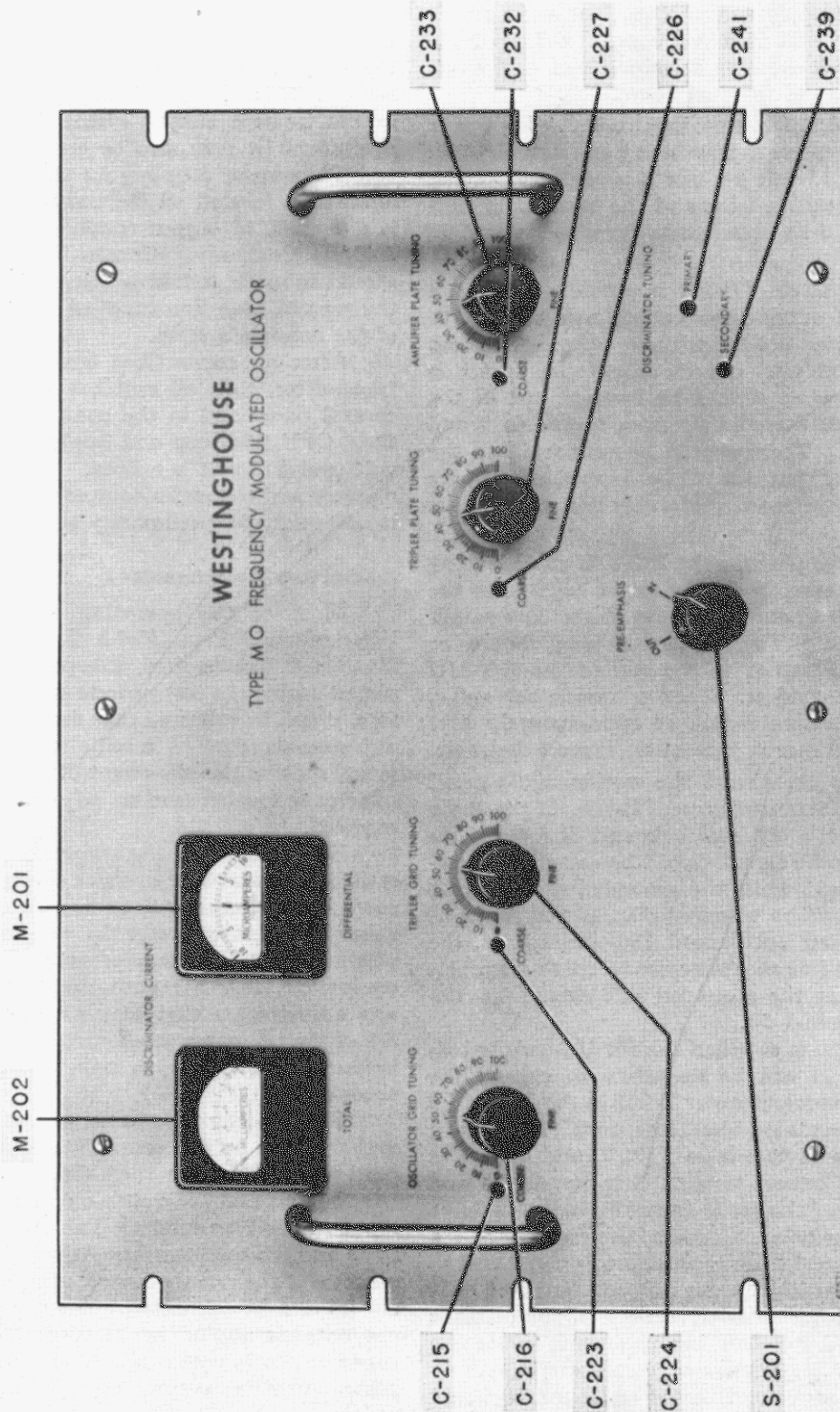

Figure 2-3—Controls on Type MO Frequency Modulated Oscillator

Trim the wires carrying the 208/230-volt 3-phase a-c line supply so that they just reach terminals 1, 2, and 3 on terminal board TB-701. Strip the wire, attach suitable terminal lugs and screw them tightly to the terminal board.

Attach the 115-volt a-c line for supplying power to the crystal heaters to terminals 7 and 8 on TB-701. If a separate 115-volt a-c line is used for supplying power to the trouble light and the two utility outlets, this should be attached to terminals 9 and 10 on TB-701.

Terminal 11 on TB-701 is provided so that a switch located outside the cubicle can be used to turn on the trouble light without opening the rear doors of the cubicle. If such an external switch is planned, two wires should be brought out of the cubicle through the conduit from terminals 9 and 11 of TB-701. These should be connected to the external switch that should be located somewhere in the transmitter room, preferably near the back of the transmitter.

A connector plug for the RG-8/U cable leading to the station monitor will be found screwed to the connector located on the bottom of the 3kw amplifier plate tank. This connector plug should be removed and attached to the end of the RG-8/U cable from the conduit. When trimming this cable, allow for a bending radius of approximately four inches. A larger radius, if practical, is more desirable.

The audio cable from the station audio panel is connected to terminal board TB-716. If the audio is supplied from a 600-ohm balanced line, the wires carrying the audio signal should be attached to terminals 51 and 52 while the grounded shield of the cable is attached to terminal 50. If the Audio is supplied from an unbalanced 150-ohm source, the high side of the line should be connected to terminals 52 and 51 while the grounded side should be connected to terminal 50.

If the audio is supplied from a 150-ohm unbalanced source, it will be necessary to change the primary taps on transformer T-201 in the Type MO Frequency Modulated Oscillator unit. Disconnect all connections to terminals 1, 2, 3, and 4 on this transformer. Connect terminal 3 to terminal 1 and connect *both* of the leads from the input cable to these two terminals. Connect terminals 2 and 4 together. Connect both terminals to ground and to the shield of the input cable. It will be noted that this connection places both sections of the primary in parallel, and parallels the two wires inside the cable, reducing its impedance correspondingly.

If the remote control unit is employed, it should be connected to terminal board TB-713 as shown on the schematic diagram, Fig. 6-2. If the remote control unit is not used, some of the terminals should be connected together as shown in Fig. 6-6.

A grounding stud is located on the floor of the cubicle near the terminal boards. A ground strap should be run from this stud to the metal frame of the building, or to the regular ground bus of the station. If local regulations require a grounded wire in the 3-phase supply system be brought to the equipment, it may also be connected to this stud.

The output coupling for the coaxial line to the antenna is located on the top of the cubicle. This is a Type 1251 output coupling made by the V. J. Andrew Company. Connections to this coupling should be made, following instructions provided with the transmission line supplied by the manufacturer of the antenna system.

After all connections have been made to the transmitter, turn all switches and breakers on the control panel and in the compartment below it to their OFF positions and apply power to the 230-volt and 115-volt a-c lines. Connect the station monitor and the audio equipment. The transmitter is now ready for preliminary adjustments.

#### Preliminary Adjustments

Most of the operating adjustments on the Westinghouse Type FM-3 Frequency Modulated Broadcast Transmitter, except tuning, were completed during the test periods at the factory. Therefore, it can be expected that most of the mechanical adjustments required in initially lining up the equipment, such as the alignment of the tuning indicator meters and other similar adjustments will not be required.

However, when the transmitter is initially installed, it is advisable to check such adjustments and correct any that may have become displaced during shipment. Consequently the paragraphs that follow will include a complete procedure for aligning the equipment, together with instructions for making any adjustments that may prove to be necessary. All of the adjustments should, however, be checked before they are made, to make certain that they are necessary.

This procedure is started with all of the switches and breakers on the control panel and in the compartment below it in their OFF position and with the 230-volt and 115-volt a-c power available at the input to the transmitter. The audio input connections and the monitor connections should have been made, and the remote control unit, if it is employed, should also be connected. The transmission line to the antenna should be in place and the antenna tuned to resonance in accordance with instructions provided by its manufacturer.

#### Adjustment of the Cubicle Control Circuits

The two Type WL5D22/4-250A driver tubes, the two Type WL473 tubes of the 3 kilowatt ampli-

fier, and the 866A and 872A rectifier tubes should be *out of their sockets* at the start of the preliminary adjustment procedure. The two Type 6Y6G tubes V-601 and V-602, the Type 6SJ7 tube, V-603, and the Type OC3/VR-105 tube, V-604, should be installed in the voltage regulator behind the large window to the left of the driver compartment. The Type 9006 tube, V-501, should be installed in the r-f voltmeter rectifier near the r-f output coupling.

Under these conditions, all of the d-c rectifiers in the transmitter are disabled except the bias rectifier in the Type MP unit and the two Rectox rectifiers employed in the tuning motor circuits. The plate caps of the rectifier tubes should be pulled away from the metal panels so that they will not short out. All access doors and windows should be closed.

### Crystal Heater Power Circuit

Place the CRYSTAL HEATER POWER breaker S-731 in the compartment behind the lower access doors on the front of the cubicle in the ON position. The amber CRYSTAL HEATER POWER indicator light I-708 near the center of the control panel will light indicating that power is being applied to the crystal heaters in the Type MP Frequency Stabilizer. The red CRYSTAL HEATER NO. 1 and NO. 2 indicator lights I-709 and I-719 will also light.

The CRYSTAL HEATER POWER indicator light I-708 will remain on continuously as long as the CRYSTAL HEATER POWER breaker S-731 is in the ON position unless there is an overload in the circuit. In that case, I-708 will go off since S-731 is a thermal overload breaker that will open up if an overload is present. If it is not possible to keep I-708 on, an overload in the circuit should be suspected and corrected.

I-709 and I-719 will remain on for a period after the circuit is first turned on, and then will go off and on with a fairly regular cycle. This action is proper, since these two lights indicate the cycling of the thermostatic switches in the crystal ovens. Regular cycling of these two lights will indicate proper operation.

### Distribution Bus Control Circuit

Place the DISTRIBUTION BUS POWER breaker S-702 in the ON position. The following indications should be noted:

1. The blower motor B-701 should be heard to start.
2. After the blower motor has reached operating speed, the white AIR INTERLOCK indicator light I-701 on the control panel should light indicating that air relay S-727 is operating since the blower motor is supplying a

sufficient supply of air to the tube sockets. Check blower motor for proper rotation. It should be rotating counterclockwise from the blower end. If rotation is incorrect, reverse the position of the leads connected to terminals 1 and 2 of terminal board TB-701.

3. The DOOR INTERLOCK indicator light I-715 should light if the two rear doors, the two glass doors on the front of the cubicle are open or if the control panel is not in its closed position. Open each of these interlocked doors and the light should go ON and the door interlock relay will be heard to operate. Close all doors so that the light remains OFF.

**NOTE:** The FILAMENT POWER ON and READY indicator lights may come on the control panel and on the remote control unit, if it is used. Put them out by operating the FILAMENT POWER switch on either the control panel or the remote control unit. It should be noted that the switching arrangement is such that, when the remote control unit is used, neither of these switches has any permanent ON or OFF position. Switching either switch to the *next* position will turn the circuit off if it is on, and vice versa.

Place the DISTRIBUTION BUS REGULATOR switch S-706 in the DECREASE position and hold it there until the powerstat it controls has run completely in that direction and has been stopped by its limit switches. Do the same with the 2500 VOLT RECTIFIER REGULATOR switch S-707. This will cause both these circuits to start in a minimum voltage condition when they are turned on.

### Filament and Distribution Bus Circuit

Place the FILAMENT POWER switch S-703 in such a position that the green READY light comes on. If the air interlock relay S-727 and the door interlock relay K-720 are operating, the filament contactor K-703 will close and the red ON light will also come on. Set the 400 VOLT RECTIFIER switch S-704 and the 2500 VOLT RECTIFIER switch S-705 so that the green READY lights beside these switches are *out*.

Set the BUS VOLTAGE switch S-738 to the DIST BUS PHASE 1 position and, by placing the DISTRIBUTION BUS REGULATOR switch S-706 in the RAISE position, raise the voltage until the BUS VOLTAGE meter M-701 indicates 230 volts.

Check the voltage on the other two phases by operating the BUS VOLTAGE switch to the DIST BUS PHASE 2 and DIST BUS PHASE 3 positions. These also should read 230 volts  $\pm 2\%$ . During the time that the voltage is being raised, the time delay

relay K-705 that prevents application of power to the rectifier circuits will cycle.

Filament power will be applied to the tubes of the voltage regulator in the compartment to the left of the driver stage. After a short period, their cathodes may be seen to glow. Filament power will also be applied to the Type MO and Type MP units and, after a short time, if they are pulled forward, they can be felt to be warm. It should be noted that pulling these units out will remove filament power from them. Consequently, unless they are pulled out rapidly, and inspected quickly, it will not be possible to notice any glow on the cathodes of the glass tubes. For this reason, feeling the tubes will be the best indication. Filament voltage will also be applied to the Type 9006 tube in the r-f voltmeter rectifier.

### Motor-Driven Tuning Circuits

With the voltage on the distribution bus set to exactly 230 volts by the DISTRIBUTION BUS REGULATOR switch, operate the TUNING switches and the COUPLING switch and watch the indicating meters above them.

Place each switch in its DECREASE position and hold it there until the tuning motor has run completely in that direction and been stopped by its limit switch. At that point, the tuning meter should read zero. Place the switch in the other position and when the limit switch stops the motor, the meter should read full scale. A small error at either end of the scale is not very important, as the tuning meters will rarely operate near the ends of the scale.

If any important deviation is found, it may be adjusted in the following manner. Operate the tuning switch until the motor drive has moved to the maximum position. This should be the point where the limit switch operates. With the rheostat located just behind the meter, set the meter to full scale. Then run the drive to the minimum position where the limit switch stops it and adjust the meter screw until the needle is at zero. Repeat these two operations until a full scale reading is obtained between the maximum and minimum positions.

If the limit switches are found to be improperly set, they can also be adjusted by loosening their set-screws on the motor drive and adjusting them so that they operate at the maximum and minimum tuning or coupling positions.

### Measuring Filament Voltages

Remove all power from the transmitter and place the Type WL5D22/4-250A driver tubes, the Type WL473 tubes of the 3 kilowatt amplifier, the two Type 866A and the six Type 872A rectifier tubes in their sockets. Re-apply power and turn on the

CRYSTAL HEATER POWER and the DISTRIBUTION BUS POWER breakers. Adjust the distribution bus voltage to exactly 230 volts with the DISTRIBUTION BUS REGULATOR control and the BUS VOLTAGE meter. Measure the filament voltages.

TABLE OF FILAMENT VOLTAGES

Tube	Trans.	Operating Voltage			Measure At
		Max.	Min.		
866A	T-705	2.5	2.62	2.38	Either Tube Socket
872A	T-706 to T-711	5.0	5.25	4.75	Each Tube Socket
WL5D22/-4-250A	T-712 T-713	5.0	5.25	4.75	Each Tube Socket
WL473	T-714 T-715	6.0	6.30	5.70	Each Tube Socket
MO/MP L.V.	T-717	6.3	6.60	6.00	J-703, 2 and 17
REG.	T-601	6.3	6.60	6.00	T-601, Terms. 5 and 7 T-601, Terms. 8 and 9

*NOTE: When making measurements inside the cubicle, turn all power off and attach meter leads to points to be measured. Locate the meter within the cubicle so that it can be seen through one of the windows. Close doors, turn power on and read meter. Do not enter cubicle when power is applied.*

### Checking Low Voltage Supply

Connect a 500 volt voltmeter between the high side of C-719 and ground. Place it where it can be seen through one of the windows of the cubicle. Re-apply power to the transmitter, turn on the filaments and wait for the time delay relay to cycle. Then turn on the 400 VOLT RECTIFIER switch S-704. The green READY light should come on and if all interlock conditions have been satisfied, the contactor K-704 will be heard to close and the red ON light will also come on. Adjust the distribution bus voltage to exactly 230 volts. The voltmeter should read 400 volts  $\pm 20$  volts to indicate satisfactory operation of this rectifier.

### Adjusting Low Voltage Regulator

Connect the voltmeter between terminal 3 on TB-601 on the voltage regulator chassis and ground, and place it within the cubicle where it can be seen through one of the windows. Turn on the transmitter up to and including the 400-volt rectifier, and read the meter. Open the window enclosing the regulator and adjust the voltage to 275 volts  $\pm 5$  volts. Opening the window will, of course, remove

power from the 400-volt rectifier. Consequently, it will be necessary to open the window while making the adjustment and close it while taking the reading. *Do not short the interlocks or relay contacts. The recommended procedure takes only a few moments longer, but is much safer!*

#### Tuning the Type MO and Type MP Units

The alignment of the Type MO Frequency Modulated Oscillator and the Type MP Frequency Stabilizer are described in a single procedure since these two units operate together to generate the frequency modulated output signal that is applied to the driver stage of the transmitter. Consequently, many of the tuning adjustments on one unit are interrelated with adjustments that must be made on the other. With the 400-volt rectifier operating and with the regulated source of 275 volts available from the low voltage regulator, this procedure is as follows:

Remove the Type 6SJ7 tube, V-201, from the Type MO unit. This renders the feedback discriminator circuit inoperative until the tube is replaced. Set the FREQUENCY CONTROL switch S-302 in the Type MP unit to the OFF position. Set the CRYSTAL OSCILLATOR SELECTOR switch S-301 to either position 1 or 2 depending upon the oscillator unit to be used. The crystal oscillator unit nearest the front panel is unit No. 1, while the other is No. 2. Both units should be checked during the tune-up process.

#### Adjusting Modulator Plate Current

Adjust the DIODE BIAS control R-345 on the front panel of the Type MP unit so that the MODULATOR PLATE CURRENT meter M-715 on the cubicle control panel reads exactly 6 milliamperes. This adjustment is quite important and should be carefully made since the current value of 6 milliamperes through the diode modulator is the proper value that establishes the ideal modulation characteristics of the tube.

#### Tuning the Crystal Oscillators

The two crystal oscillator units have been very carefully tuned before being shipped from the factory and will normally require no attention. It should be noted that the accuracy of a few cycles required for operation of an amplitude-modulated transmitter within the normal broadcast band is not required from these units, due to the wider frequency tolerance of frequency modulated operation. Consequently, their adjustment is not nearly as critical as with a normal broadcast transmitter.

However, if it is necessary to tune the oscillator units, the following procedure may be employed.

The tuning controls consist of three screwdriver adjustments on the top of the chassis of each unit. C-405 tunes the tank circuit in the screen of the oscillator that operates on the fundamental frequency of the crystal, while C-406 tunes the tank circuit in the plate of the tube. This latter tank circuit is tuned to double the crystal frequency. C-401 is a small capacitor in parallel with the crystal that may be used to set the frequency over a narrow range to the specified crystal frequency.

The crystal oscillator units should be tuned up separately with only one unit inserted in the Type MP unit. C-405 should be tuned for a cathode current of 7.0 ma. on the low capacity side of the cathode current dip while C-406 is tuned for maximum dip, as shown on the CRYSTAL OSCILLATOR CATHODE CURRENT meter M-301 on the front panel of the Type MP unit. The low capacity side of the dip in cathode current is that side where the current varies more slowly with tuning of C-405. When both oscillators have been tuned up separately, they may be put in the MP unit. With both oscillators in, the individual cathode currents will increase from 7.0 to 9 or 10 ma., due to loading of each oscillator's plate circuit by the plate circuit of the other.

#### Tuning the Modulated Oscillator Grid Circuit

Adjust the FINE tuning (knob adjustment) to approximately the center of the scale and tune with the COARSE (screwdriver adjustment) of the OSCILLATOR GRID TUNING control on the front panel of the Type MO unit until the BEAT INDICATOR LIGHT I-302 on the front panel of the Type MP unit lights. This indicates that the oscillator grid circuit is tuned to the approximate frequency for proper operation. The FINE tuning adjustment mentioned above serves for all frequencies in the range except for the extreme frequencies near the end of the operating range 88 and 108 megacycles. At these frequencies it will be necessary to adjust the FINE control near the end of its range and proceed as described.

Place the FREQUENCY CONTROL switch in the Type MP unit in the ON position. If the grid circuit in the MO unit is now tuned to the proper frequency and the Type MP unit has taken control of the frequency, the FINE GRID TUNING CONTROL may now be tuned about operating point and the current on the MODULATOR PLATE CURRENT meter M-715 will vary with the tuning of the oscillator grid. This indicates that the Type MP unit is supplying an AFC voltage to the modulator control tube and that the oscillator frequency is being stabilized. The FINE OSCILLATOR GRID CONTROL should be able to vary the modulator plate current through a range of from 2 to 12 milliamperes on the meter.



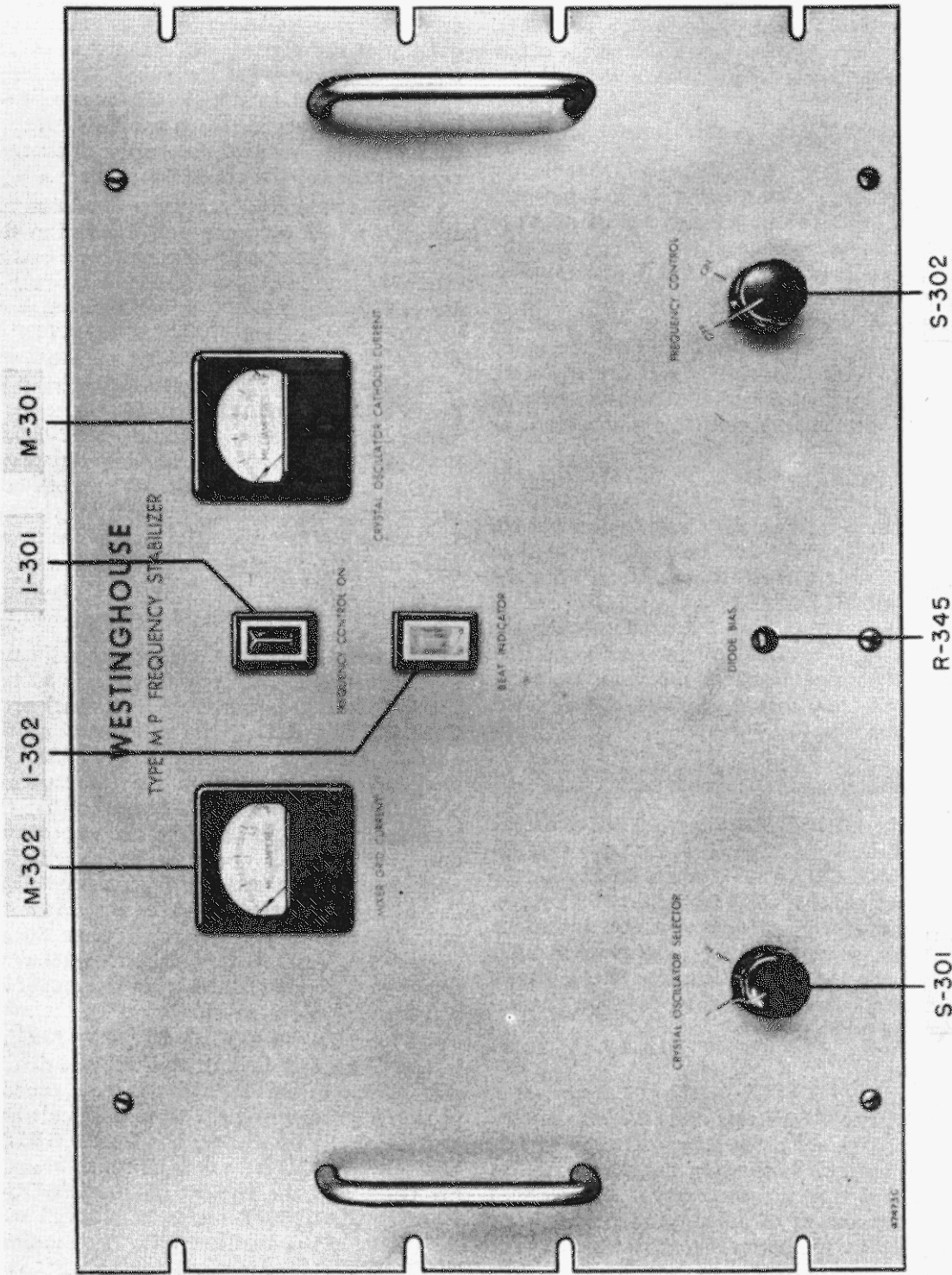

Figure 2-4—Controls on Type MP Frequency Stabilizer

Adjust the FINE OSCILLATOR GRID TUNING control so that the current read on the MODULATOR PLATE CURRENT METER on the control panel is exactly 6 milliamperes.

#### Adjusting Mixer Grid Current Control—MP Unit

This control tunes the plate tank circuit of V-301, the Type 6SJ7 buffer amplifier in the Type MP unit. It is located on the top of the chassis just behind V-301. The adjusting screw carries 105 volts d-c and it should be tuned only with a well insulated, low-capacity adjusting tool. Tune this adjustment for maximum current shown on the MIXER GRID METER M-302 on the Type MP unit.

#### Tuning the Tripler Grid Control—MO Unit

Tune the COARSE TRIPLER TUNING control with the FINE knob adjustment set at about the center of the scale until a dip is noted on the MODULATED OSCILLATOR PLATE CURRENT meter M-720 on the control panel. Then adjust the FINE adjustment until a maximum dip is obtained. The plate current should then be about 55 to 65 milliamperes. At the same time, a maximum reading on the TRIPLER GRID CURRENT meter M-719 of between 7 and 9 milliamperes should be obtained.

The oscillator grid tuning should be checked, and, if necessary, should be readjusted to provide a reading of 6 milliamperes on the MODULATOR PLATE CURRENT meter M-715 on the control panel.

#### Tuning the Tripler Plate Circuit—MO Unit

Set the FINE TRIPLER PLATE control at approximately the center position on the scale and tune the COARSE control for a dip in the current shown on the TRIPLER PLATE CURRENT meter M-718 on the control panel. Tune for maximum dip with the FINE control. When maximum is assured, the plate current should be between 130 and 160 milliamperes on the TRIPLER PLATE CURRENT meter. At the same time, a current of approximately 15 to 20 milliamperes should show in the amplifier grid circuit as shown by the INTERMEDIATE AMPLIFIER GRID CURRENT meter M-717.

#### Tuning the Intermediate Amplifier Plate Circuit—MO Unit

With the FINE INTERMEDIATE AMPLIFIER TUNING control set at about the center of the scale, tune the COARSE tuning control until a dip is noticed in the current on the INTERMEDI-

ATE AMPLIFIER PLATE CURRENT meter M-716. Tune for maximum dip with the FINE control. Check the DRIVER GRID CURRENT meter M-703 in the row of supervisory meters in the top of the front of the cubicle for evidence of grid current to the driver stage of the transmitter.

Tune the DRIVER GRID TUNING switch on the control panel for minimum grid current on the DRIVER GRID CURRENT meter to secure an unloaded condition on the intermediate amplifier. Retune the intermediate amplifier plate circuit on the MO unit for maximum dip with the FINE tuning control. The current shown on the INTERMEDIATE AMPLIFIER PLATE CURRENT meter should be approximately 100 milliamperes without a load on the amplifier.

Tune the DRIVER GRID CURRENT control for maximum grid current on the DRIVER GRID CURRENT meter, and retune the intermediate amplifier for maximum dip. The grid current reading should be approximately 40 to 50 milliamperes and the intermediate amplifier plate current should be approximately 150 milliamperes when proper loading conditions have been obtained.

In addition to the above adjustments described, it may be necessary to remove the Type MO unit from the cubicle and adjust C-235 for a maximum reading on the DRIVER GRID CURRENT meter M-703 in order to obtain optimum results. This can be accomplished with the aid of the service cable supplied with the equipment.

#### Discriminator Tuning Adjustment

The discriminator is a band set type with the band set controls accessible from the bottom of the Type MO unit while the vernier controls are screw-driver adjustments accessible through holes in the lower right hand corner of the front panel. The following procedure should be used at the time of installation of the transmitter for the initial tuning up. Subsequent adjustments of the discriminator that may be necessary from time to time to compensate for aging or other small changes in circuit conditions, may be made from the front panel without removing the unit from the cubicle. For the initial adjustment proceed as follows:

Remove the Type MO unit from the cubicle and install the service cable. It has previously been mentioned that the Type 6SJ7 tube be removed while tuning the discriminator. Refer to the photograph of Type MO unit, bottom view, to locate the primary and secondary tuning controls of the discriminator. An insulated adjusting tool held in place by two small clips is located near the discriminator. Adjust the PRI. bandset for a maximum reading of the TOTAL DISCRIMINATOR CURRENT

meter M-202. Adjust the SEC. bandset until a sharp swing to the left and right through zero is observed on the DIFFERENTIAL DISCRIMINATOR CURRENT meter M-201. The final adjustments should be made with the vernier screwdriver controls accessible from the front panel previously mentioned. These controls are at ground potential and therefore no body capacity effects will be present. The PRIMARY control, as before, should be adjusted for a maximum reading on the TOTAL DISCRIMINATOR CURRENT meter and the SECONDARY control adjusted so that the DIFFERENTIAL DISCRIMINATOR CURRENT meter reads zero. The above description of the tuning of the discriminator may indicate that it is a tedious and difficult operation, but once the operator has familiarized himself with the procedure it will be found that it is readily accomplished without difficulty.

The discriminator may be checked for proper tuning and operation by turning the FREQUENCY CONTROL switch on the Type MP unit to the OFF position and changing the OSCILLATOR GRID TUNING, FINE control on the MO unit five divisions each direction from its original setting and observing the DIFFERENTIAL DISCRIMINATOR CURRENT meter. If the discriminator is tuned properly, the above meter will read to the left of zero for one direction of movement of the GRID TUNING control and to the right of zero for the other direction of movement of the GRID TUNING control. If such is not the case, it will be necessary to repeat the tuning of the discriminator secondary circuits. After the discriminator is operating correctly, replace the Type 6SJ7 tube in the MO unit and plug the unit back in the cubicle.

#### Pulse Balance Adjustment

This adjustment serves to equalize the amplitude of the pulses applied to the pulse integrator stage. Two small screwdriver adjustments C-348 and C-349 will be found located close together near the right hand side of the Type MP unit chassis. Normally, these adjustments are properly set at the factory and the following test should be made to determine if adjustment is necessary.

Check the carrier frequency without modulation and measure it accurately. Apply a balanced sine wave modulation and modulate to a maximum swing of  $\pm 100$  kilocycles. Measure the frequency under modulation. If the swing is equal above and below the carrier frequency and the center frequency does not drift, no adjustment is necessary.

If the modulation is unbalanced, and the center frequency drifts in either direction, tune these two controls until the center frequency is steady at the assigned point.

When making this adjustment, set one of the capacitors, e.g., C-348, at maximum capacity and adjust C-349 for the required results. If a satisfactory condition cannot be reached, set C-349 at maximum capacity and adjust C-348 for the best results.

#### Check of Cathode Follower V-313

A gassy, leaky Type 6SL7 Tube will cause the pulse integrator capacitor to discharge at an unduly rapid rate and will affect, to some extent, the stability of the carrier when the other circuits are adjusted properly. This will occur especially during periods of no modulation, or when modulation is light.

To check the condition of this tube, adjust the FREQUENCY CONTROL switch to the center position. Watch the MODULATOR PLATE CURRENT meter for a change in modulator plate current. A change of 2 milliamperes in 10 seconds will indicate an imperfect tube and the tube should be replaced.

To check the condition of the pulse counter tubes V-311 and V-312, turn the FREQUENCY CONTROL switch on, and adjust the CRYSTAL OSCILLATOR SELECTOR switch S-301 to the center position, cutting out both crystal oscillators. A change in modulator plate current more rapid than that occurring when V-313 was checked indicates that either one or both of the pulse counter tubes V-311 and V-312 are imperfect and should be replaced separately with tubes known to be good.

#### Tuning the Driver Stage

With the Type MO and the Type MP units tuned up, adjust the DRIVER GRID TUNING switch operating the motor driven tuning capacitor C-701 so that maximum current is obtained on the DRIVER GRID CURRENT meter M-703.

Now adjust DRIVER INPUT LOOP TUNING CAPACITOR C-702, located on driver grid assembly, see Fig. 2-5, and DRIVER INPUT LOOP L-714, so that optimum coupling between the Type MO unit and the driver grid is obtained.

If the driver grid current peak does not occur when the intermediate amplifier plate circuit is tuned through the dip, adjustment of C-235 in the Type MO unit may be necessary. The adjustment is not critical and need be made but once for a particular frequency. C-235 is located below the output coupling coil in the intermediate amplifier section in the Type MO unit and is adjusted from beneath the chassis by means of the screwdriver slot in the capacitor shaft.

To make the adjustment, turn off the low voltage, remove the MO unit from the cubicle, and

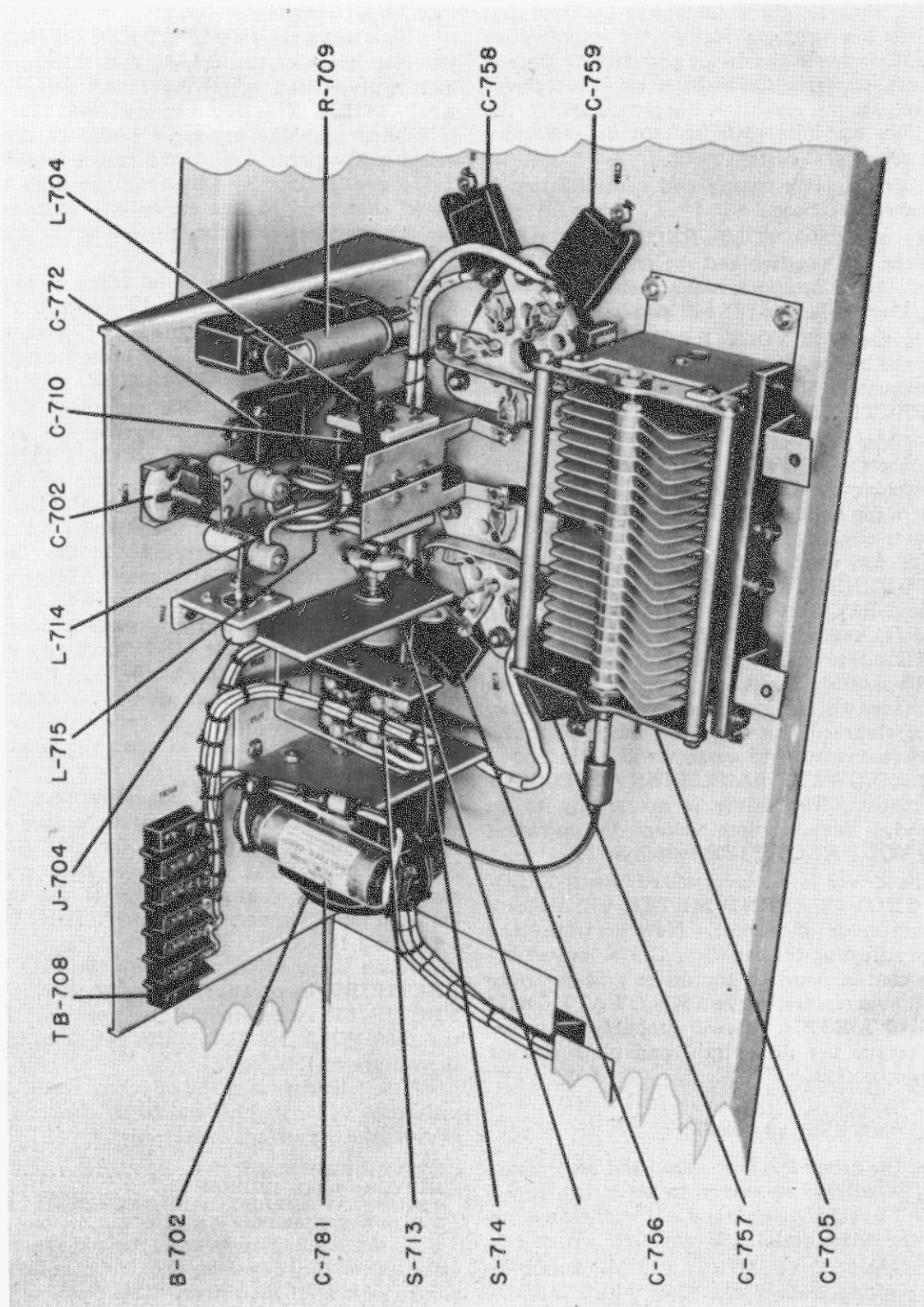

Figure 2-5—Driver Grid Assembly

change C-235 by a small amount. Replace the MO unit, allow time for the filaments to heat up; and turn on the low voltage. Retune the intermediate amplifier, C-702, and the driver grid circuit. Repeat the process, changing C-235 by a small increment each time, until a condition is reached where the intermediate amplifier plate current dip coincides with the driver grid current peak.

The driver plate tuning and neutralization is accomplished as follows:

Place the 2500 VOLT RECTIFIER switch S-705 in the ON position and the ready light I-704 will light. If all interlock requirements have been satisfied, the ON light I-707 will also light.

Place the 2500 VOLT REGULATOR switch S-707 in the increase position and raise the voltage to approximately 500 volts as shown on the 2500 VOLT RECTIFIER METER near the top of the cubicles.

Operate the DRIVER PLATE tuning control while watching the DRIVER PLATE CURRENT meter for a dip which will indicate resonance in the driver plate circuit. Adjust the DRIVER PLATE TUNING for maximum dip on the DRIVER PLATE CURRENT METER. This should occur when the DRIVER PLATE TUNING indicating meter M-711 reads approximately mid-scale. If it does not indicate mid-scale at the resonant point, adjust the shorting bar on the driver plate tank so that resonance will occur at approximately mid-scale. It will be observed that when the driver plate circuit is in resonance, grid current will be indicated on the 3 KILOWATT AMPLIFIER GRID CURRENT meter. The driver is now ready to be neutralized. Remove plate voltage by operating the 2500 VOLT RECTIFIER switch S-707.

If the driver is not neutralized, the 3 KILOWATT GRID CURRENT METER will indicate some small value of current. Now neutralize the driver by adjusting the capacitor C-705, located behind the control panel on the driver grid assembly for a minimum reading on the 3 KILOWATT GRID CURRENT METER. It will probably be necessary to retune the driver grid and plate circuits after this operation.

**Adjusting the 3 Kilowatt Amplifier**

After the driver has been tuned and neutralized properly, it will be necessary to neutralize the 3 KILOWATT AMPLIFIER and adjust the coupling between the driver and 3 KW amplifier.

Place the 2500 VOLT RECTIFIER switch in the ON position. Place the 2500 VOLT REGULATOR switch in the INCREASE position and raise the voltage to approximately 500 volts. Operate the 3 KW PLATE TUNING switch for mini-

imum current on the 3 KILOWATT AMPLIFIER PLATE CURRENT meter.

Shut down the 2500 VOLT RECTIFIER; open the rear doors of the cubicle and disconnect the high voltage lead supplying the 3 KILOWATT AMPLIFIER. This lead is located on C-713. C-713 is located near the top right center of the back shield to the right of the two filament transformers T-714 and T-715. Two high voltage leads will be found connected to this capacitor. Remove only the one that dresses to the left feeding the 3 KILOWATT AMPLIFIER plate.

In transmitters after Serial 56783 a removable link has been placed in the lead between C-713 and the 3 KILOWATT AMPLIFIER. This link is located at C-713 and should be open for neutralizing the 3 KILOWATT AMPLIFIER.

Close the cubicle doors and place the 2500 VOLT RECTIFIER switch in the ON position. Some current will be noticed on the TRANSMISSION LINE VOLTAGE meter. This will indicate that the amplifier must be neutralized. Neutralize the amplifier by adjusting C-707 and C-708 simultaneously for minimum reading on the TRANSMISSION LINE VOLTAGE meter. These capacitors will be found located just under the 3 KILOWATT AMPLIFIER and can be reached by opening the control panel. It will be necessary to hold down the panel interlock switch S-739 during this operation. The capacitors should be adjusted in such a manner that they read approximately equal on the small calibrated dials when the amplifier is neutralized.

To facilitate the proper adjustment of the DRIVER PLATE loading and the setting of the cathode input tap on the 3 KILOWATT AMPLIFIER cathode tank, curves have been prepared showing the approximate settings of the shorting bars and input tap versus frequency. Refer to Figs. 2-12 and 2-13.

Make these adjustments with the 2500 VOLT RECTIFIER inoperative. Place the 2500 VOLT RECTIFIER switch in the ON position. Adjust the 2500 VOLT REGULATOR switch to increase the voltage to 1500 volts.

The following is a set of meter readings (approximate values) which should be obtained if the above adjustments are correct:

DRIVER GRID CURRENT.....	45 MA
DRIVER PLATE CURRENT.....	325 MA
3 KILOWATT AMPLIFIER GRID CURRENT.....	0.24 AMP
3 KILOWATT AMPLIFIER PLATE.....	1.0 AMP

If the readings appear to be too far off, the driver plate coupling loop should be adjusted for proper loading of the driver. This coupling loop is accessible through the front window of the cubicle and is assembled to the driver plate tank shorting bar.

AT 1500 VOLTS!

\* SEE PAGE 33 FOR FULL POWER READINGS!

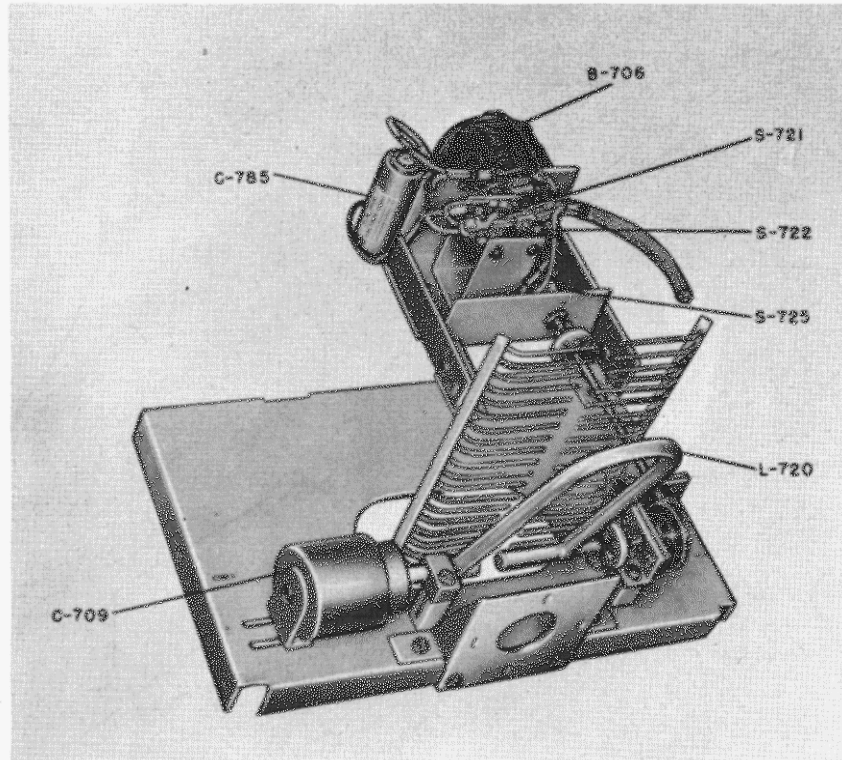

Figure 2-6—3 Kilowatt Output Coupling Loop Assembly

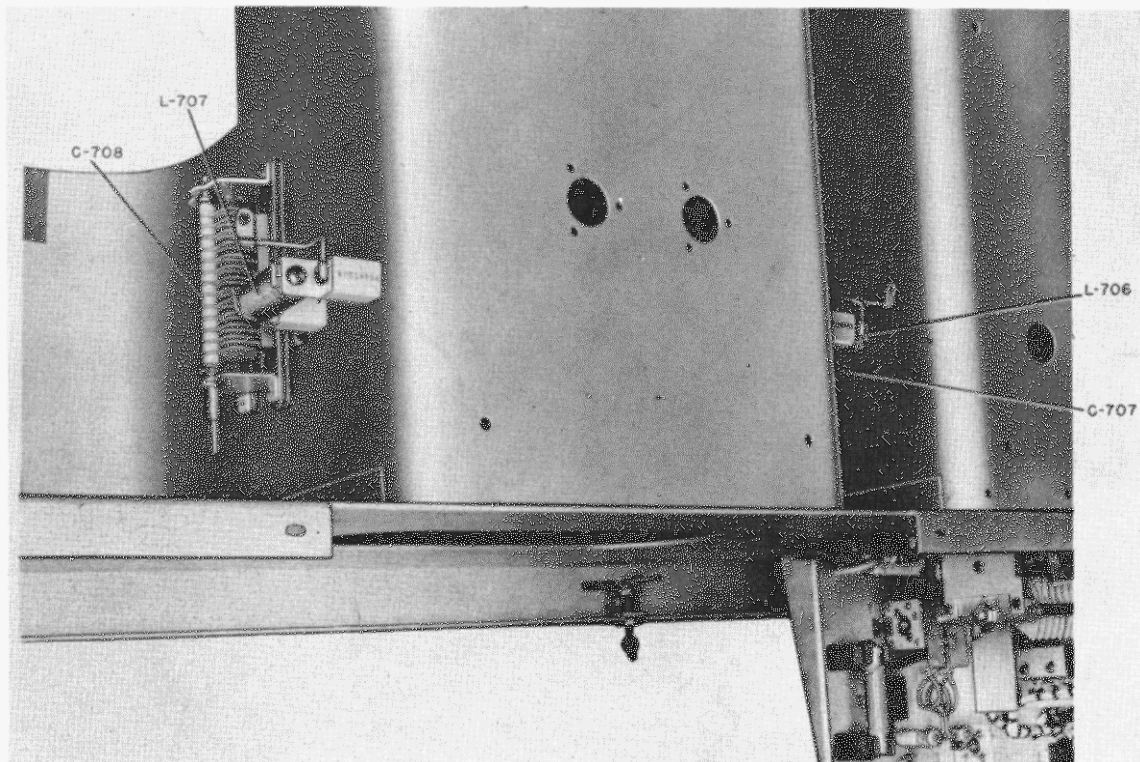

Figure 2-7—3 Kilowatt Grid Capacitor and Choke

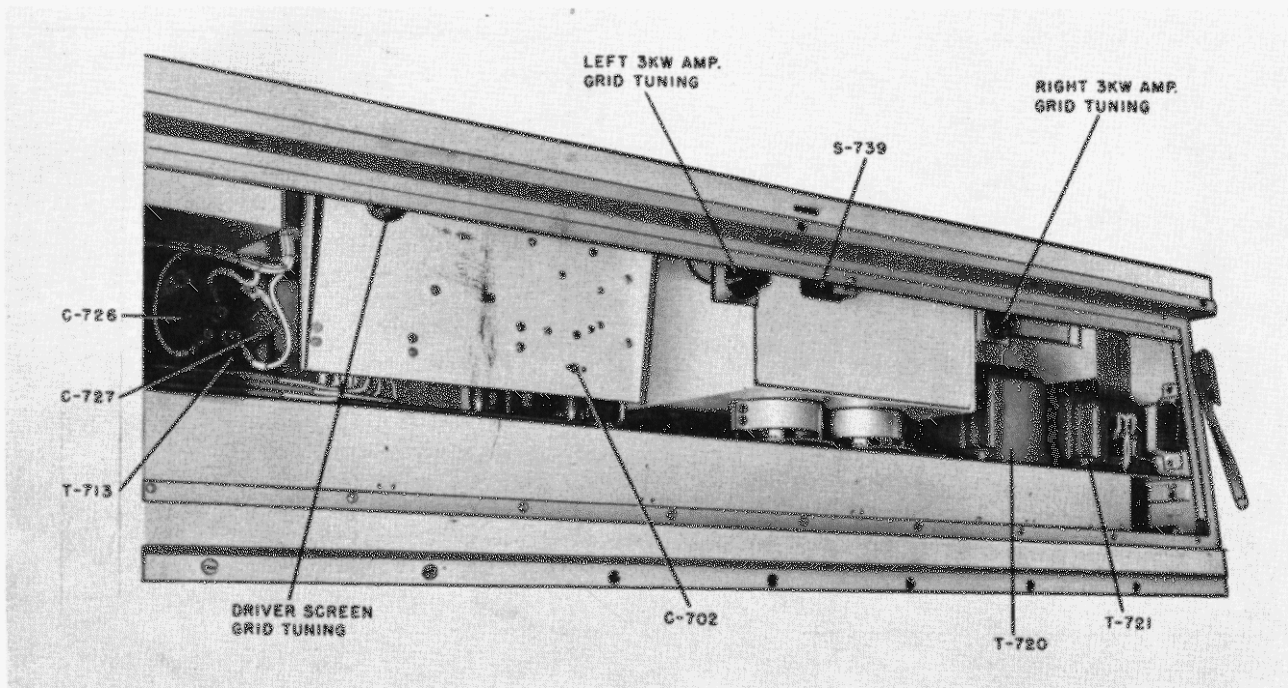

Figure 2-8—Driver and 3 KW Amplifier Neutralizing Controls

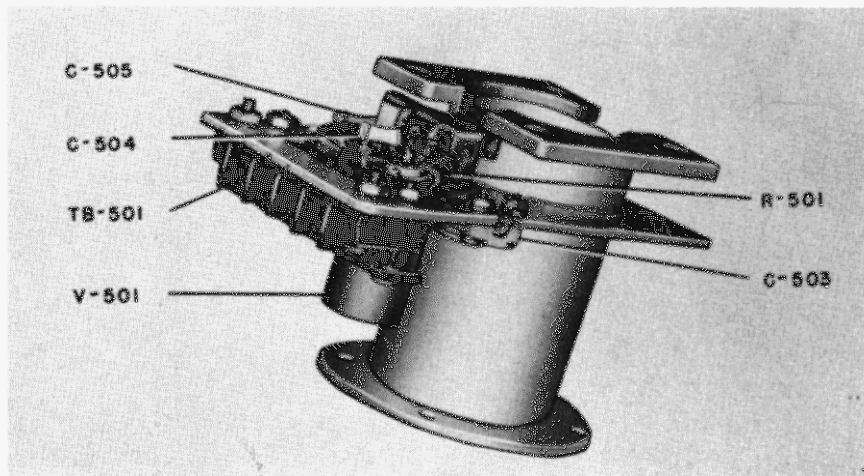

Figure 2-9—Transmission Line Voltmeter Assembly

For optimum operation, the antenna coupling loop tuning capacitor C-709 should be adjusted to tune out the reactance of the antenna coupling loop. This capacitor is assembled to the 3 KILOWATT AMPLIFIER plate tank shorting bar. (See photograph). After the transmitter is tuned up and operating, this circuit may be checked by varying the 3 KILOWATT AMPLIFIER LOADING and determining if the 3 KILOWATT AMPLIFIER PLATE TUNING remains in tune with different degrees of loading. If it detunes badly with different adjustments of loading, the capacitor C-709 should be adjusted in its slotted mounting holes until a value of capacity is found which tunes out the reactance of the antenna coupling loop and the amplifier plate tuning is affected only slightly by loading.

After the DRIVER AMPLIFIER and 3 KILOWATT AMPLIFIER are tuned and loaded properly as indicated by the above outlined adjustments and meter readings, the plate voltage may be increased to 2500 volts. 3 kilowatts output should then be obtained. A typical set of meter readings with an FM-3 Transmitter delivering 3 kilowatts output is given below. It should be recognized that the TRANSMISSION LINE VOLTAGE meter reading given here is based on the transmitter working into a 51.5 ohm load having a standing wave ratio of one to one.

METER	INDICATION
Bus Voltage (M-701) Positions 1, 2 & 3 of S-738.....	230 Volts
Driver Grid Current (M-703).....	42 MA
Driver Plate Current (M-704).....	0.6 AMP
3 Kilowatt Amplifier Grid Current (M-705).....	0.45 AMP
3 Kilowatt Amplifier Plate Current (M-706).....	1.74 AMP
2500 Volt Rectifier (M-707).....	2500 Volts
Transmission Line Voltage (M-709).....	394 Volts
Modulator Plate Current (M-715).....	75 .6 MA
Intermediate Amplifier Plate Current (M-716).....	180 MA
Intermediate Amplifier Grid Current (M-717).....	16 MA
Tripler Plate Current (M-718).....	120 MA
Tripler Grid Current (M-719).....	9 to 12 MA
Modulated Oscillator Plate Current (M-720).....	68 MA
Total Discriminator Current (M-202).....	0.2 to 0.35 MA
Differential Discriminator Current (M-202).....	0 MA
Mixer Grid Current (M-302).....	0.25 to 0.5 MA
Crystal Oscillator Cathode Current (M-301).....	9 MA

The r-f output power of the transmitter may be obtained by multiplying the plate voltage on the last stage by the plate current of the last stage by the efficiency factor .69

The meter indications given in the previous table represents average performance of the Westinghouse Type FM-3 Transmitter. Different conditions will provide slightly different readings. How-

ever, these values represent normal conditions that will be encountered in most installations and are given here as standards of comparison.

**Summary**

It can normally be expected that the initial alignment of the Westinghouse Type FM-3 Frequency Modulated Transmitter will be accomplished without any unusual conditions occurring. If any troubles occur, they may be easily located by reference to the schematic diagrams, Figs. 6-2, 6-3, 6-4, and 6-5, and the wiring diagrams, Figs. 6-6, 6-7, 6-8, 6-9, 6-10, and 6-11. Suggestions for rapidly locating possible troubles will be found in Part V, Maintenance and Trouble-Shooting.

The procedure employed in the operation of the Westinghouse Type FM-3 Frequency Modulated Broadcast Transmitter is largely dependent upon the operating practices at the broadcast station, the monitoring and audio equipment associated with it and upon the preferences of the station engineers. Consequently no fixed procedure can be recommended by the manufacturer.

This section contains a complete description of the various mechanical and tuning adjustments necessary to align the transmitter for proper operation. A table of meter readings that is representative of average normal operation is also given.

From this information the station engineers can develop a practical operating procedure for use at the station, assigning the various operations to the personnel and determining the schedule by which the various operations should be performed.

**REMOTE CONTROLS AND INDICATORS.**

Provision is made for attaching a remote control unit to the transmitter that will contain switches duplicating the FILAMENT POWER, 400 VOLT RECTIFIER, 2,500 VOLT RECTIFIER, the DISTRIBUTION BUS REGULATOR and the 2,500 VOLT RECTIFIER REGULATOR switches on the control panel. Duplicates of the indicator lights associated with the first three switches may also be provided at the remote position. When remote control is employed, and the main breakers are on supplying power to the circuits, the transmitter may be operated from either the remote position or at the console.

Provision is also made for connecting a remote voltmeter in parallel with the TRANSMISSION LINE VOLTAGE meter so that output conditions of the transmitter may be indicated at a remote position.



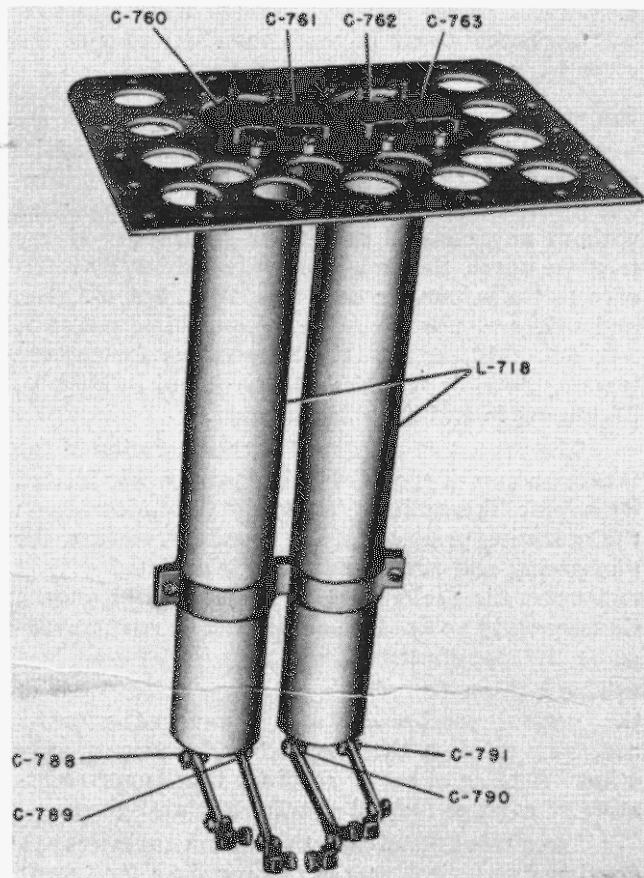

Figure 2-10—3 Kilowatt Amplifier Cathode Tank Assembly

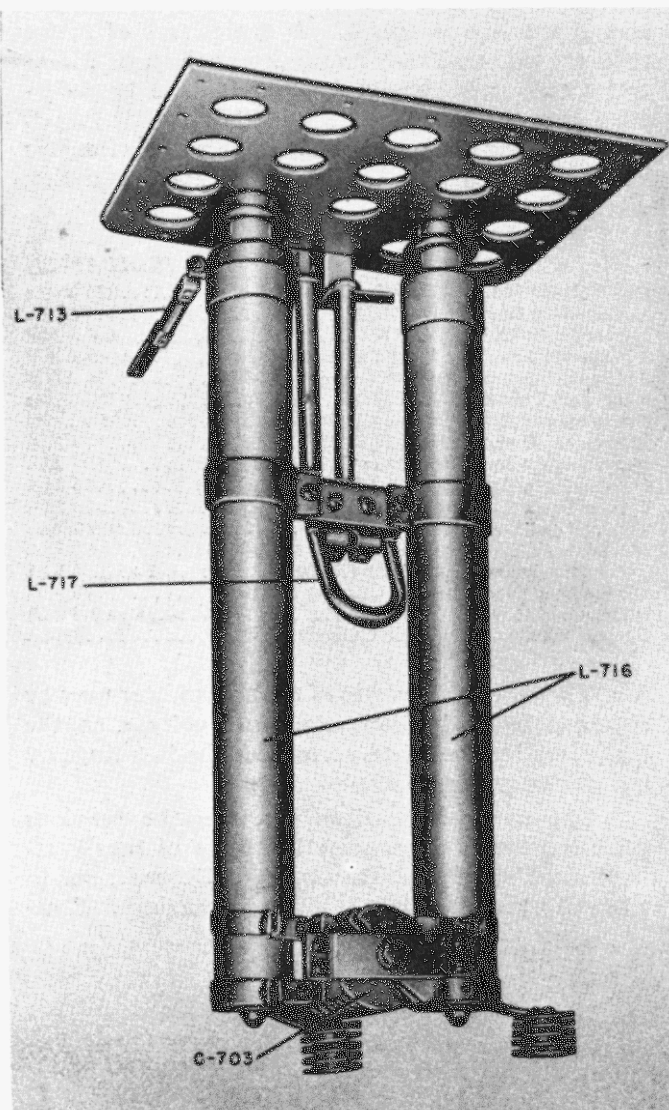

Figure 2-11—FM-3 Driver Amplifier Plate Tank Assembly

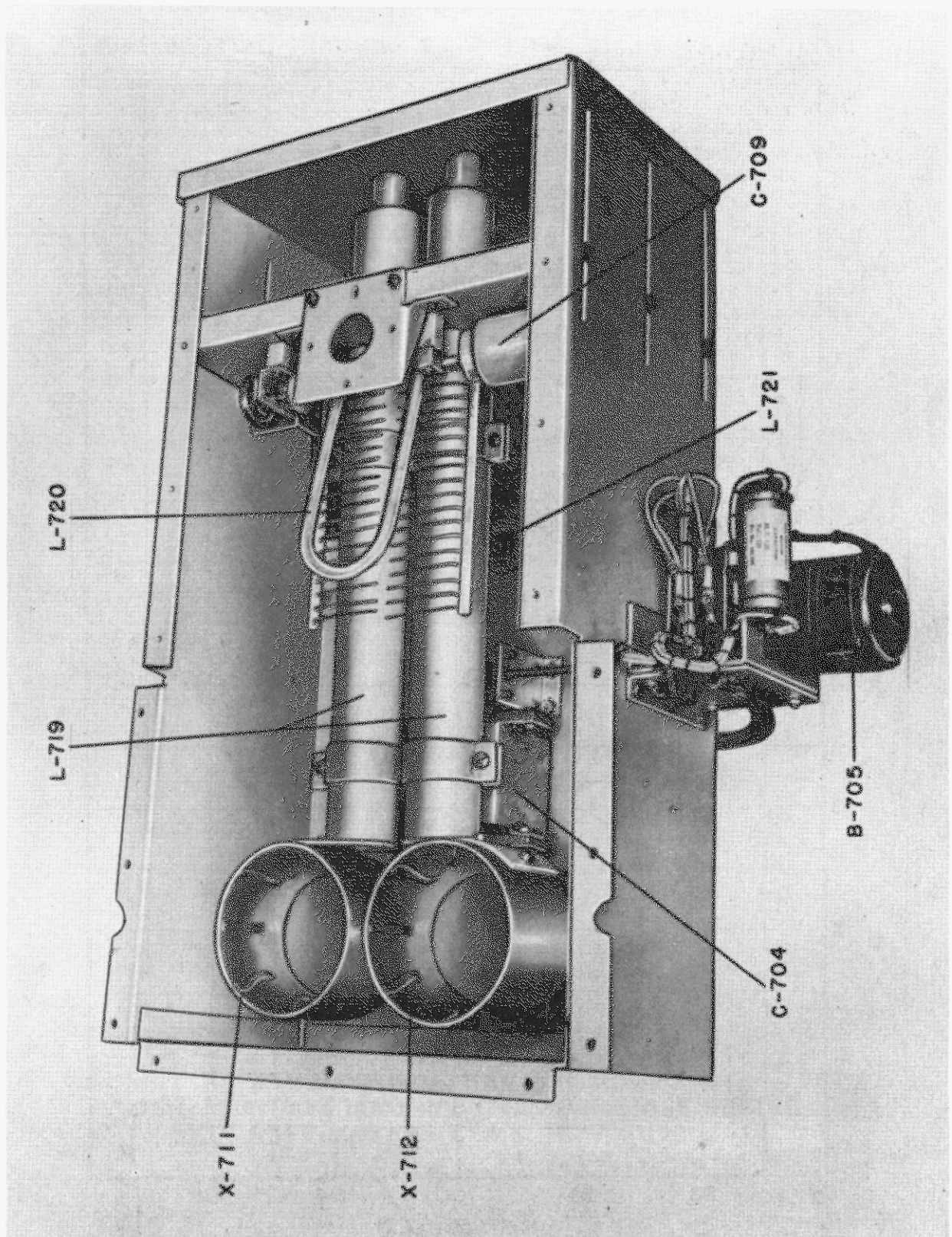

Figure 2-12—3 Kilowatt Amplifier Plate Tank Assembly

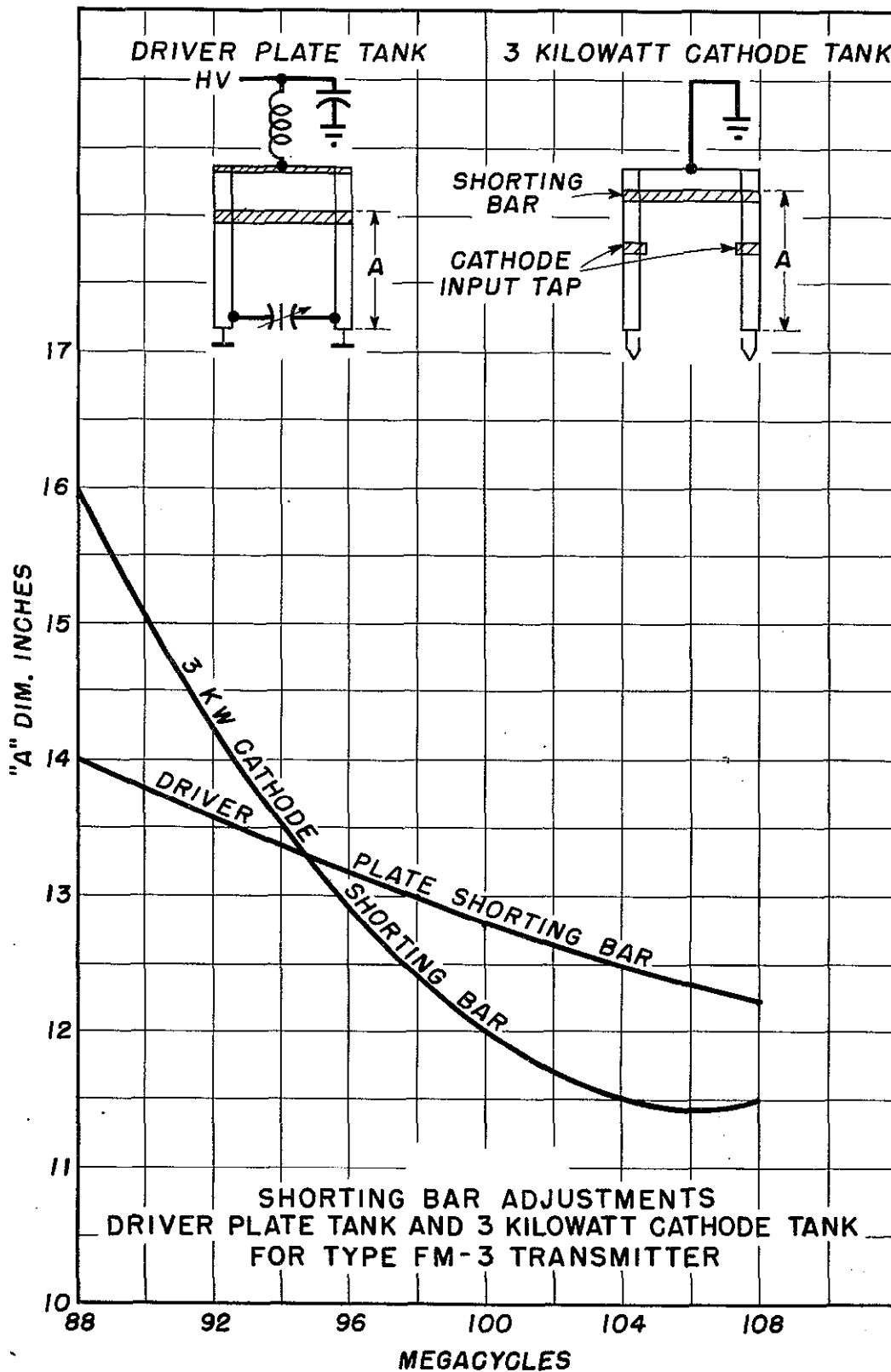

Figure 2-13—Shorting Bar Adjustments, Driver Plate Tank and 3 KW Cathode Tank for Type FM-3 Transmitter.

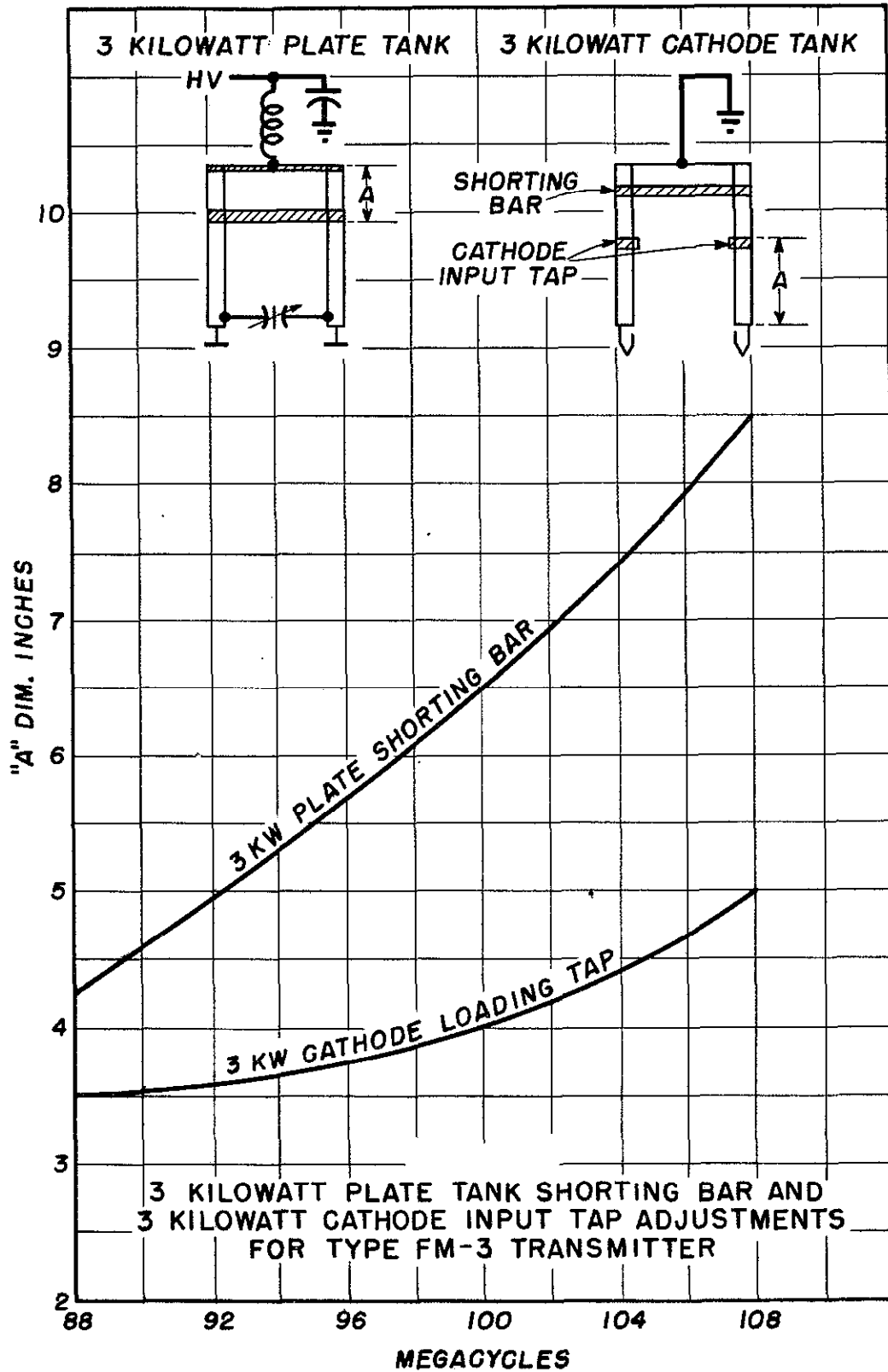

Figure 2-14—3 KW Plate Tank Shorting Bar and 3 KW Cathode Input Tap Adjustments for Type FM-3 Transmitter

**PLACING THE TRANSMITTER ON THE AIR.** When the transmitter is known to be tuned up properly, the crystal ovens are at operating temperature as indicated by the regular flashing of their indicator lights, and the **FREQUENCY CONTROL** switch on the Type MP unit is in the ON position, the following operations will place the transmitter on the air:

1. Place the **DISTRIBUTION BUS POWER** breaker in the ON position and adjust voltage to 230 volts.
2. Place the **FILAMENT POWER** switch in the ON position. Wait 30 seconds for the time delay relay to cycle.
3. Turn on the **400 VOLT RECTIFIER** switch.
4. Place the **2,500 VOLT RECTIFIER** breaker in the ON position.
5. Place the **2,500 VOLT RECTIFIER** switch in the ON position and adjust the voltage to 2,500 volts.

**REMOVING THE TRANSMITTER FROM THE AIR.** This can be accomplished by placing the following switches in their off position in the order indicated:

1. **2,500 VOLT RECTIFIER** switch.

2. **400 VOLT RECTIFIER** switch.
3. **FILAMENT POWER** switch.
4. **2,500 VOLT RECTIFIER POWER** breaker.
5. **DISTRIBUTION BUS POWER** breaker.
6. **CRYSTAL POWER** breaker, if the transmitter is to be off the air for a considerable period of time. This breaker is normally left on for overnight shut-downs.

**NOTE:** If power is removed from the transmitter with the switches and breakers in the ON position, the transmitter will come on automatically when power is returned. Consequently, in case of power failure, always shut down the transmitter by placing the switches and breakers in the OFF position; otherwise, the transmitter will automatically return to the air when power is restored.

**OPERATING THE TRANSMITTER AS A DRIVER.** Provisions are made in the control circuit for operating some of the primary circuits of higher power amplifiers, such as the filament circuits, etc., from the control switches of the Type FM-3 Transmitter. These provisions can be seen on the schematic diagram, or special information will be supplied by the manufacturer upon application to the nearest Westinghouse District Office.

# PART THREE

## THEORY OF OPERATION

The circuits of the Westinghouse Type FM-3 Frequency Modulated Broadcast Transmitter are conservatively designed for continuous duty broadcast service. Every effort has been made to keep the electrical design as simple as possible and to make certain that all components are conservatively rated for reliable service under the rigorous requirements of broadcast service.

This section of the instruction book includes a discussion of the theory of operation of the various circuits. For the sake of simplification, the circuits have been divided into the following six general classifications:

1. Radio Frequency Generating Circuits
2. Audio Frequency Modulating Circuits
3. Frequency Stabilizing Circuits
4. Radio Frequency Amplifying Circuits
5. D-C Rectifier Circuits
6. A-C Distribution and Control Circuits

Under the heading, "General Functioning of the Circuits" is given a short description of the manner in which the various circuits function, while a more complete and detailed description is given under the heading "Detailed Functioning of the Circuits" later in the section.

### General Functioning of the Circuits

**RADIO FREQUENCY GENERATING CIRCUITS.** The circuits that determine the radiated frequency of the transmitter are located in the Type MO Frequency Modulated Oscillator Unit. They are shown in the upper section of the functional diagram, Fig. 3-1. The frequency modulated oscillator is a type 1614 tube connected in a Colpitts electron-coupled oscillator circuit. The grid circuit operates on a frequency that is 1/9 the output frequency of the transmitter. The plate circuit is tuned to 1/3 the output frequency so that the stage operates as both an oscillator and tripler.

One of the frequency-determining elements in the grid circuit is a reactance type diode modulator, or frequency control tube. It is connected in such a manner that it presents a reactance across the grid inductor. The value of the reactance presented by the modulator is determined by the current flowing through the tube at any given instant. This, in turn, is established by the instantaneous voltage applied to the grid of the modulator control tube.

The audio frequency modulating voltage, when applied to the modulator control tube, will cause the reactance of the modulator tube to vary, thus varying the frequency of the oscillator and giving the desired frequency modulated characteristics to the output.

Accurate centering of the frequency modulated carrier on the assigned frequency is also obtained by applying a control voltage from the frequency stabilizing circuits to the modulator control tube.

The output of the oscillator stage is applied to a push-pull tripler stage employing a type 829B tube. The output of this stage is at the assigned frequency of the transmitter. The tuning circuits employed in this stage, and the other stages in the transmitter, provide adequate selectivity without attenuating the sideband frequencies when the carrier is modulated to the full  $\pm 100$  kilocycle swing from the assigned carrier frequency.

The output of the type 829B tripler stage is amplified by a type 829B class C push-pull radio frequency amplifier. The output of this stage is link-coupled to the Radio Frequency Amplifying Circuits in the transmitter cubicle.

**AUDIO FREQUENCY MODULATING CIRCUITS.** These circuits are also located in the Type MO Frequency Modulated Oscillator unit. They amplify the audio frequency signal supplied by the speech amplifying equipment of the station, and apply it to the oscillator grid tank in the form of a varying reactance presented by the type 6H6 diode modulator tube.

The reactance presented by the type 6H6 modulator varies at the audio frequency rate of the program signal, and the amplitude of the variation is dependent upon the amplitude of the program signal voltage at any given instant. The amplitude of the program signal voltage, therefore, determines the amplitude of the frequency excursion of the oscillator, providing the frequency modulated characteristics desired in the output signal. Since the reactance of the modulator serves to establish the instantaneous frequency of the carrier, the stabilizing signal from the Type MP Frequency Stabilizer is also applied to the audio circuits so as to establish the carrier at the proper center frequency assigned to the station.

The Audio Frequency Modulating Circuits receive the audio signal from the station's speech amplifying equipment through a 600 or 150 ohm balanced line to an input transformer. The secondary output of this transformer is supplied to the grid of a type 6SJ7 class A amplifier through a 75 microsecond pre-emphasis network. The use of the pre-emphasis circuit is optional and a switch is provided to cut it in or out as desired.

Inverse feedback to maintain a high order of linearity in the audio stages is secured by a double-diode discriminating circuit that demodulates a small radio frequency voltage from the oscillator

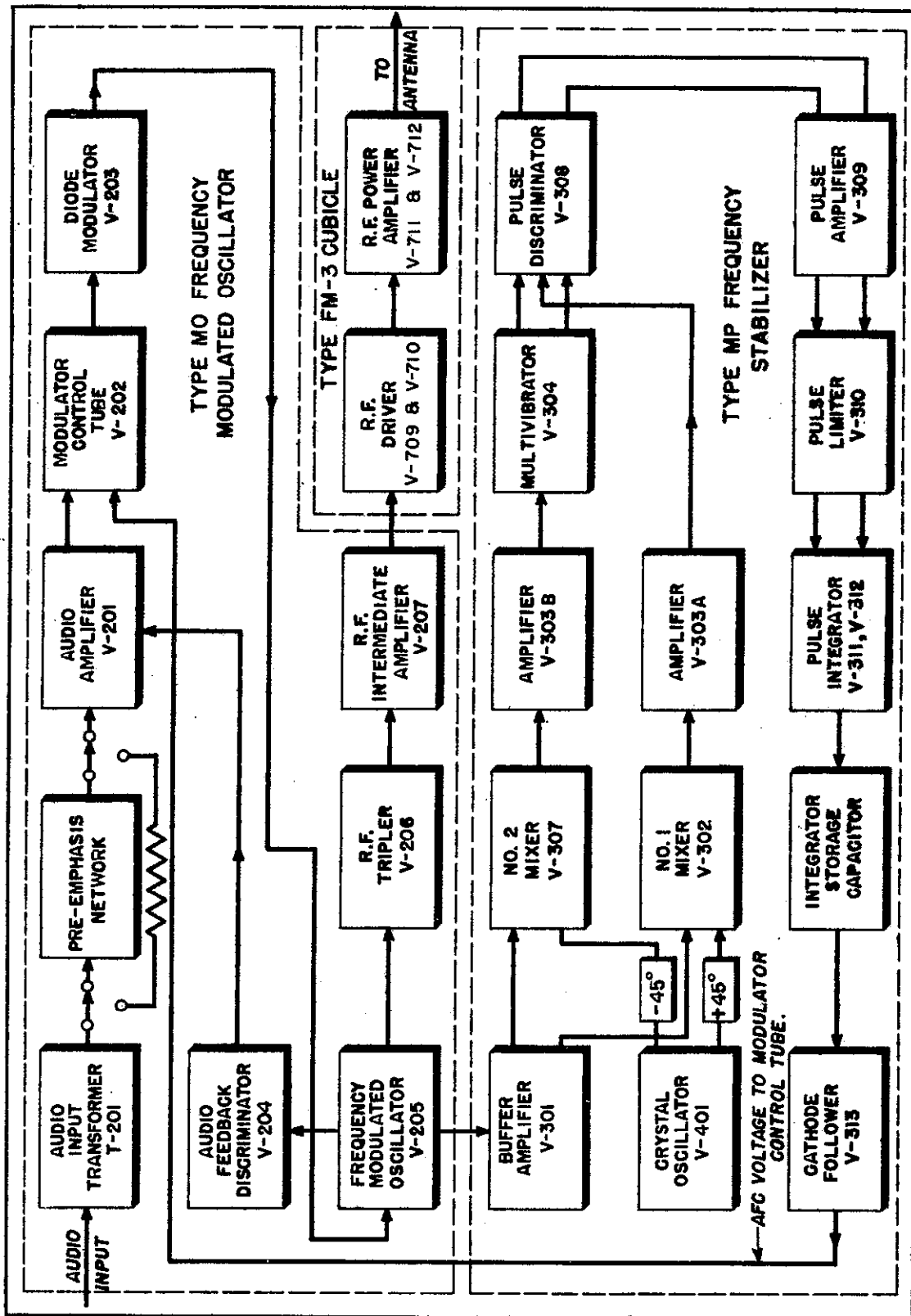

Figure 3-1—Functional Block Diagram of the Type FM-3 Transmitter

grid circuit and applies the resultant audio frequency signal to the grid of the audio input stage.

The output signal from the audio input stage is resistance-coupled to the grid of the modulator control tube. This tube is a class A voltage amplifier. Its plate current flows through the 6H6 diode modulator in such a manner that the reactance presented by the diode across the oscillator grid tank circuit will depend upon the instantaneous value of the current flowing through the diode. This action will be explained in more detail later in this part of the instruction book.

#### FREQUENCY STABILIZING CIRCUITS.

These circuits are located in the Type MP Frequency Stabilizer unit. They are shown in the lower portion of the block diagram, Fig. 3-1. The operation of these circuits controls the modulated oscillator so that the frequency excursions above and below the assigned center frequency of the station will be equal during any single cycle of the modulating voltage. They also serve to stabilize the carrier at within  $\pm 1$  kilocycle of the assigned frequency when no modulation is present.

The standard of reference is a crystal-controlled oscillator-doubler stage that has an output frequency of  $1/9$  the station's assigned center frequency. This is the same frequency that is present in the grid circuit of the modulated oscillator when the oscillator is properly tuned and when no modulation is present. The output of the crystal oscillator is applied to two phase-shifting networks. One of these shifts the phase forward  $45^\circ$  while the other retards it  $45^\circ$ . The two resultant voltages are heterodyned in two mixer stages with a voltage derived from the grid circuit of the modulated oscillator.

The output of these mixer stages, when the modulated oscillator frequency differs from that of the crystal oscillator output will be a frequency that is the difference between the two frequencies. The output of one mixer is used to drive a multivibrator that generates a series of voltage spikes at the heterodyne frequency. The output of the other mixer is amplified and the result is a sine wave voltage at the same frequency.

The output of these two mixers will be  $90^\circ$  out of phase due to the mixer action. One output will lead the other when the carrier is above the reference frequency and will lag it when below. The two outputs, the voltage pips from the multivibrator and the sine wave are amplified and applied to a pulse discriminator.

The discriminator combines the two outputs in such a manner that positive pulses are present in one side of the circuit when the carrier frequency is above the reference frequency and are present in the other side when the carrier frequency is below it. Under linear modulating conditions the carrier

frequency will be above the reference frequency for one half of a modulating cycle and below it during the second half. Also the frequency excursions will be of the same magnitude.

Consequently, when the carrier frequency is exactly centered the number of positive pips appearing in the two sides of the discriminator will be equal during one complete modulating cycle. When the carrier frequency is not centered, more pips will appear in one side of the discriminator than the other, the side depending on the direction of the decentering.

These pips are amplified and the resultant current pulses are applied to an integrating circuit in such a manner that the pips in one direction will add to the charge on an integrating capacitor while pips from the other side will subtract from the charge.

The output of this integrating circuit controls a cathode follower that develops the automatic frequency control voltage that is applied to the modulator control tube to establish the center frequency of the transmitter.

The net result of the operation of the stabilizing circuits is to produce an automatic frequency control voltage that will be of a certain value when the center frequency is correct, but will vary in one direction when the center frequency is above the assigned frequency, and in the other when it is below it. The direction of variation is such that it will tend to correct the error, and return the frequency to the established center frequency for proper operation.

A more complete description of the action of these circuits will be found under the heading "Detailed Functioning of the Circuits" later in this section of the instruction book.

**RADIO FREQUENCY AMPLIFYING CIRCUITS.** The output of the Type MO unit is applied to the radio frequency amplifying circuits of the transmitter. These circuits consist of the Driver Stage and the 3 Kilowatt Amplifier Stage shown in Fig. 3-1.

The Driver stage is a push-pull class C amplifier employing two type WL5D22/4-250A tubes. The output of the Type MO unit is applied to the grid circuit through a low impedance coaxial line. The grid tank is a conventional type inductor and variable capacitor circuit and is tuned by a motor operated from the control panel. The plate circuit is a linear tank assembly tuned, also, by a motor-driven capacitor. Link coupling from the plate tank is employed to couple the output to the 3 kilowatt amplifier stage.

The 3 kilowatt amplifier is a grounded-grid, cathode-driven push-pull class C amplifier employing two type WL473 tubes. Low-impedance coupling, through a short transmission line, is employed to



drive the amplifier. A motor-driven coupling arrangement is employed to couple the amplifier to a 51.5-ohm transmission line to the antenna.

**D-C RECTIFIER CIRCUITS.** Three vacuum tube rectifier circuits and two Rectox copper oxide rectifier circuits are employed to furnish operating voltages for the various circuits of the transmitter.

The 400-volt rectifier, employing two type 866A tubes in a full-wave rectifying circuit supplies an output of +400 volts d-c for operation of the circuits in the Type MO and Type MP units. Part of the output of this rectifier is applied to a voltage regulator in the cubicle that supplies +275 volts of regulated direct current for the circuits in these two units that require regulated voltage.

A low-voltage rectifier employing a type 6X5GT tube, located in the Type MP unit, provides an output of -105 volts that is used as a bias voltage for that unit.

The 2,500 volt rectifier employs six type 872A tubes in a full-wave three-phase rectifier circuit for the Driver and 3-kilowatt amplifier stages. This rectifier is provided with a motor-driven voltage regulator that permits the output voltage to be varied from 0 to 3000-volts and that is to be used to adjust the voltage to 2,500 volts when the transmitter is being tuned.

The two Rectox rectifier circuits are employed in the motor-driven control circuits and the supervisory relay circuits. One of the circuits provides 5 volts d-c to operate the tuning indicator meters while the other has an output of 24 volts that is used to operate the supervisory relays and that is also applied as a braking voltage to the motors driving the tuning elements and the two voltage regulators.

**A-C DISTRIBUTION AND CONTROL CIRCUITS.** The a-c distribution circuits are clear and straightforward. A voltage regulator is supplied to permit adjustment of the voltage on the distribution bus and another regulator is provided for the 2,500-volt rectifier.

Interlocks are provided so that the various rectifier circuits can be turned on only in their proper order when putting the equipment on the air. Door interlocks, an air relay and a time-delay relay are also provided and interlocked with the a-c control circuits to protect the equipment and personnel.

A complete description of the distribution and control circuits is provided under the heading "Detailed Functioning of the Circuits" later in this part of the instruction book.

### Detailed Functioning of the Circuits

The preceding paragraphs in this part of the instruction book have described, in general terms, the functions of the various circuits of the transmitter. The paragraphs that follow will describe,

in detail, the electrical action of the various circuits with particular reference to their various components.

Reference to the functional block diagram, Fig. -31, to the cubicle schematic Fig. 6-2, the Type MO Frequency Modulated Oscillator schematic, Fig. 6-3, the Type MP Frequency Stabilizer schematic, Fig. 6-4 and to the various simplified drawings included in the text will be helpful when reading the descriptions that follow.

### Radio Frequency Generating Circuits

These circuits generate, at a low power level, the output radio frequency signal of the transmitter. They are located in the Type MO Frequency Modulated Oscillator and are comprised of the frequency modulated oscillator-tripler V-205, the r-f tripler V-206, the r-f intermediate amplifier V-207, and their associated components. It will be noted from the schematic diagram, Fig. 6-3, that two tuning controls are provided for all of the tuned circuits. One of these is a COARSE screw-driver adjustment used to tune the circuit to the approximate frequency while the other is a FINE knob-operated adjustment to tune the circuit to exact resonance.

**FREQUENCY MODULATED OSCILLATOR-TRIPLER.** This stage consists of a type 1614 tube in a Colpitts type electron-coupled oscillator-tripler circuit. The grid circuit operates at a frequency of 1/9 of the output frequency of the transmitter and this frequency is tripled in the plate circuit to 1/3 the output frequency.

The grid circuit is tuned by the grid inductance L-202, the coarse and fine variable capacitors C-215 and C-216, and by the capacitive reactance of the modulator tube V-203. When modulation is present in the audio circuits of the transmitter, V-203 presents a varying reactance that serves to vary the frequency of the grid of the oscillator-tripler, and thus produce the frequency modulated output of the transmitter. The manner in which this modulator reactance is varied will be described under the heading of "Audio Frequency Modulating Circuits" later in this part of the instruction book.

For this analysis of the oscillator-tripler circuits, the modulator may be considered as a varying reactance that varies at a rate determined by the frequency of the audio signal voltage, and with an amplitude of variation proportional to the amplitude of the audio voltage. Since the reactance of the modulator is present as a frequency-determining element, it can be seen that the result of applying audio voltage to the modulation circuits will be to vary the frequency of the oscillator at a rate and with an amplitude to produce the desired frequency modulated characteristics in the radio frequency output of the transmitter.

A small pick-up loop is coupled to the grid inductance to pick up a small r-f voltage for application to the audio feedback discriminator that is employed in the audio circuits.

L-205 is the plate inductance of the oscillator-tripler. With L-206 it forms a secondary-tuned coupling circuit with a very large coefficient of coupling since the two inductances are inter-wound on one form. Consequently it is tuned simultaneously with L-206 by the grid tuning capacitors of the r-f tripler stage to a frequency of 1/3 of the output of the transmitter.

The cathode current of the oscillator-tripler is indicated on the MODULATED OSCILLATOR PLATE CURRENT meter M-720 on the control panel. D-C power for the stage is supplied by the +275-volt output of the voltage regulator in the cubicle.

**R-F TRIPLER STAGE.** This stage consists of a type 829B dual beam power tube in a push-pull class C tripler circuit. The grid inductance L-206 is tuned by the coarse and fine tuning capacitors C-223 and C-224 as described in the previous paragraph.

The grid current of the stage is indicated on the TRIPLER GRID CURRENT meter M-719 and the cathode current is indicated by the TRIPLER PLATE CURRENT meter M-718 on the control panel of the cubicle.

The plate circuit of the tripler stage consists of inductance L-207 tuned by the coarse and fine tuning capacitors C-226 and C-227 to the output frequency of the transmitter. D-C power for this stage is supplied by the low voltage, 400-volt rectifier in the cubicle.

**R-F INTERMEDIATE AMPLIFIER.** The intermediate amplifier is a type 829B tube in a class C push-pull amplifier circuit that is capacitively coupled to the r-f tripler stage. Its grid current is indicated on the INTERMEDIATE AMPLIFIER GRID CURRENT meter M-717 while its cathode current is shown by the INTERMEDIATE AMPLIFIER PLATE CURRENT meter M-716 on the transmitter control panel.

The plate circuit consists of inductance L-208 tuned by the coarse and fine tuning capacitors C-232 and C-233. The r-f output of the stage is link-coupled to the driver grid circuit in the cubicle through the low-impedance link L-209 and a coaxial transmission line.

#### Audio Frequency Modulating Circuits

The audio frequency modulating circuits accept the audio signal voltage from the station's audio equipment, apply the required degree of pre-emphasis, and provide the modulating reactance at the grid circuit of the oscillator-tripler to give the

desired frequency modulated characteristics to the r-f output of the transmitter.

The modulator stages also receive the automatic frequency control voltage from the Type MP Frequency Stabilizer that controls the center value of the modulating reactance so as to maintain the carrier frequency at the proper operating point.

These circuits are comprised of the audio amplifier V-201 with its input transformer and pre-emphasis network, the modulator control tube V-202, the diode modulator V-203 and the audio feedback discriminator V-204 shown on Figs. 3-1 and 6-3.

The audio frequency response of the transmitter without pre-emphasis, over a range of 30 to 15,000 cycles, is  $\pm 1$  db from response at 1,000 cycles. With pre-emphasis, the response is  $\pm 1$  db from a 75 microsecond curve. The audio input for a  $\pm 75$  kilocycle swing is +10 dbm at 400 cycles. Harmonic distortion is less than 1.5% for modulating frequencies between 50 and 15,000 cycles including all harmonics up to 30 kilocycles, measured at a  $\pm 75$  kilocycle modulation swing.

**AUDIO FREQUENCY AMPLIFIER STAGE.** The audio frequency amplifier consists of the type 6SJ7 tube V-201, the 600/150-ohm line-to-grid input transformer T-201, the 75-microsecond pre-emphasis network formed by C-202 and R-206 and the other components associated with the tube.

The tube is triode-connected and operates as a class A amplifier. Switch S-201, the PRE-EMPHASIS switch on the front panel of the Type MO unit, permits the pre-emphasis network to be switched in and out of the grid circuit of the tube. When the pre-emphasis network is in use, capacitor C-202 and the 220,000 ohm resistor R-206 in parallel replace the 220,000-ohm resistor R-204 in series with the grid input circuit. The capacitor slightly distorts the leading edge of each audio frequency wave, emphasizing the frequency swing on the higher modulation frequencies. The action of this network provides a pre-emphasis in accordance with a 75-microsecond curve as required by Federation Communications Commission regulations.

Capacitor C-201 and resistor R-201 form a high-frequency filter to bypass to ground the higher audio frequencies above the desired operating range of the transmitter.

The output of the tube, appearing across the plate resistor R-225 is capacitively coupled to the grid of the modulator control tube by capacitor C-240. The 275-volt plate supply for the stage is from the voltage regulator in the cubicle.

An inverse feedback voltage, derived from the audio feedback discriminator stage is coupled to the grid of the audio amplifier through resistor R-207. This feedback voltages improve the linearity of the audio circuits and the frequency response of the transmitter.

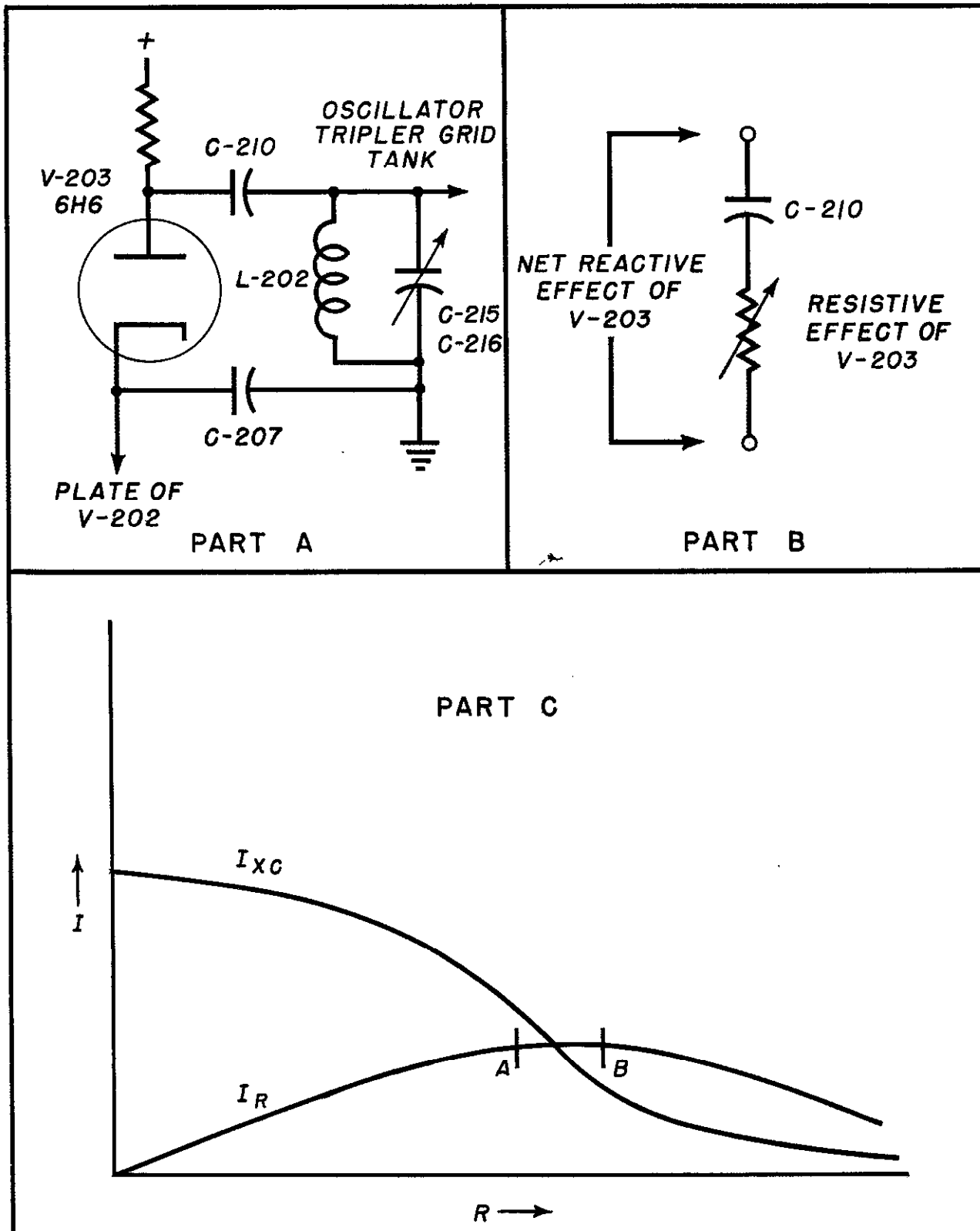

Figure 3-2—Resistive and Reactive Current in Diode Modulator

**MODULATOR CONTROL TUBE.** The modulator control tube is a type 1614 beam power tetrode that is connected as a triode and operated as a class A audio frequency amplifier. It serves to control the current drawn through the diode modulator V-203, in series with its plate circuit, and thus to establish the reactance characteristics of the modulator.

Two control voltages are applied to the grid of the tube. The first is the amplified audio signal that is capacitively coupled to it from the plate of the audio amplifier V-201. Due to the characteristics of a class A amplifier, the current drawn through the modulator tube due to the audio signal is always proportional to the instantaneous grid voltage of the audio signal. This causes the current through the modulator tube, and consequently its reactance, to vary in a positive and negative direction during each modulation cycle.

The second input applied to V-202 is the automatic frequency control voltage supplied by the Type MP Frequency Stabilizer. This voltage determines the static operating conditions of the tube and thus establishes the static reactance characteristics of the modulator at a value that will cause the frequency modulated oscillator-tripler to provide the proper frequency required when no modulation is present. It also establishes the point from which the reactance will vary in both a positive and a negative direction to cause the frequency to swing above and below the assigned carrier frequency of the station.

**DIODE MODULATOR.** The modulator is a type 6H6 double diode tube with its two sections in parallel. It is connected in series with the plate circuit of the modulator control tube V-202, and consequently the instantaneous current through the diode is dependent upon the current through V-202. The diode type modulator has been chosen for the Type FM-3 transmitter since it provides a greater freedom from noise effects than does a conventional reactance modulator. Also it is easier to establish its operating range so that the amplitude modulation of the oscillator is practically eliminated.

Referring to Part A of the simplified diagram, Fig. 3-2, it can be seen that the capacity of the diode appears across the grid inductance of the oscillator-tripler due to the presence of C-210 and C-207. In addition to the capacity of the diode, an element of resistance is also present due to the current flowing through the diode and the resultant voltage drop across it. This resistance appears in the circuit as a resistor in series with the capacity of the tube, as indicated in Part B of Fig. 3-2.

The reactance of the modulator is equivalent to the capacitive effect and the resistive effect in series. In such a network, varying the value of the resistor will cause a change in the net reactive effect.

The variation in the resistive effect is produced by changing the instantaneous current through the tube. This in turn, varies the reactance presented by the tube across the grid circuit of the oscillator-tripler. As was explained in the description of that circuit, the frequency of the oscillator-tripler is varied to produce frequency modulation in accordance with the changes in the reactance of the modulator.

The primary problem of design in any type reactance modulator is to, as far as possible, minimize any changes in the voltage drop across the modulator tube. For these changes would be transferred to the oscillator circuit as changes in voltage appearing at the grid of the oscillator-tripler and would cause amplitude modulation of its output. This is avoided in the 6H6 diode modulator by operating the tube at a point where the change in resistive current through the tube is very small in proportion to the change in reactive current.

A plot of the currents through the 6H6 tube is shown in Part C of Fig. 3-2. It will be noted that, between the points A and B, a very small change in resistive current  $I_R$  occurs for a relatively large change in the resistive effect of the tube. Yet, between these two points, the change in capacitive current is considerable by comparison.

Consequently, by setting the operating conditions of the tube so that it operates between A and B, a change in reactance is secured that is practical for modulation purposes and yet is free from characteristics that would cause amplitude modulation.

In the case of the modulator employed, a static current of 6 milliamperes through the diode, shown on the MODULATOR PLATE CURRENT meter M-715 will establish proper operating conditions and permit variations in either direction sufficient to provide a maximum frequency swing of  $\pm 100$  kilocycles.

D-C voltage for the modulator control tube and the modulator is provided by the low voltage regulated supply in the cubicle.

**AUDIO FEEDBACK DISCRIMINATOR.** This circuit provides an audio feedback loop around the modulator, modulator control tube and the audio amplifier and provides an inverse feedback voltage to the grid of the audio amplifier V-201. It consists of the type 6H6 tube V-204 in a conventional center-tuned discriminator circuit similar to that used as a detector in many types of frequency modulated receivers. It produces the inverse feedback voltage by demodulating a small voltage picked up from the grid circuit of the oscillator-tripler by the coupling link L-203, a coaxial line, and L-213.

The primary and secondary inductances, L-211 and L-212, are tuned by C-241 and C-239, respectively. These two capacitors are the DISCRIMINATOR TUNING PRIMARY and SECONDARY

screwdriver adjustments on the front panel of the Type MO Frequency Modulated Oscillator and are employed to align the discriminator circuits. Two meters are provided to simplify tuning the circuit. These are the DISCRIMINATOR CURRENT TOTAL meter M-202 and the DISCRIMINATOR CURRENT DIFFERENTIAL meter M-201 on the front panel of the Type MO unit.

When the primary of the discriminator is tuned to resonance with the oscillator-tripler, maximum current will flow through M-202. When the secondary is properly resonated the current through M-201 will be zero.

When both the primary and secondary are tuned to resonance with the oscillator-tripler grid frequency, the voltage applied to the type 6H6 tube will consist of two components. One of these will be a push-pull voltage induced in the secondary by the inductive coupling while the other will be the voltage fed to the center of the secondary by capacitor C-214. These two voltages, due to the coupling characteristics will be 90 degrees out of phase at the plates of the discriminator tube.

This means that the secondary push-pull voltage will lead the primary voltage by 90° on one plate of the tube while it will lag it 90° on the other. Rectification will produce a d-c voltage flowing in one direction through R-210 and in an opposite direction through R-211. These two voltages will be equal in amplitude as long as the 90° phase relationship is maintained.

When the carrier deviates from the frequency to which the primary is tuned the secondary will either lag or lead the primary to an extent different than 90°. This phase shift at the plates of the tube causes a greater current to flow in either R-210 or R-211, depending upon the direction of the deviation. Consequently the output of the circuit, when the carrier is modulated at an audio frequency, will be a d-c voltage varying at the rate and amplitude of the carrier deviation. Output voltage is applied to the grid of the audio amplifier as an inverse feedback voltage through isolation resistor R-207.

#### Frequency Stabilizing Circuits

These circuits are located in the Type MP Frequency Stabilizer. They provide an automatic frequency control voltage that is applied to the modulator control tube to establish the center frequency of the transmitter output at the assigned station carrier frequency. They accomplish this by comparing a small voltage derived from the grid circuit of the oscillator-tripler with a signal from a reference crystal oscillator and by causing a change in the automatic frequency control voltage that will return the oscillator-tripler center frequency to its proper point whenever it moves from the reference frequency.

The operation of these circuits is such that the center frequency of the station is maintained within  $\pm 1$  kilocycle of the assigned carrier frequency at the maximum carrier swing of  $\pm 100$  kilocycles.

Reference to the schematic diagram, Fig. 6-4 will show that the operation of these circuits does not depend upon tuned circuits for its accuracy as do certain types of stabilizing systems. Also, as will be explained in the following paragraphs, practically all of the critical tubes in the circuit operate from grid current condition to cut-off. Therefore, the tube characteristics themselves play almost no part in the stability of the circuit. There are no frequency dividers or locked oscillators in the circuit, and no special tuning or test instruments are required to place the circuits in operation. Continuous checking and tuning are therefore unnecessary and the circuits once aligned, will operate over long periods of time without more than routine attention.

The functional relationship of the various circuits in the Type MP Frequency Stabilizer can be seen from the block diagrams Fig. 3-1 while the actual circuits themselves are shown on the schematic diagram, Fig. 6-4, and on the simplified schematic diagrams of the more complicated stages that will be found along with the descriptions.

D-C power for these circuits is supplied from the 400-volt low voltage supply in the cubicle and a -105 volt regulated bias supply is included on the Type MP chassis to provide bias voltage. A voltage regulator is included on the chassis that provides a regulated +105 and a regulated +255-volt supply for the various tubes in the unit.

**BUFFER AMPLIFIER.** The buffer amplifier receives a signal voltage from the grid tank circuit of the oscillator-tripler through a pick-up loop and a coaxial line. It amplifies this voltage and applies it to the grids of two mixer tubes. The stage consists of the type 6SJ7 tube V-301 and its associated components shown in the shielded compartment on the schematic diagram Fig. 6-4. The tank circuit consists of inductance L-301 tuned by capacitor C-305. C-305 is the screwdriver adjustment located on the top of the Type MP chassis just behind the 6SJ7 tube. A loading resistor, R-303 is included to broaden the peak of the tuning curve to prevent the necessity for critical adjustment of C-305 for different input frequencies.

The circuit is tuned to resonance by tuning C-305 until maximum grid current is indicated on the MIXER GRID CURRENT meter M-302 on the front panel of the unit.

Plate voltage for the tube is supplied by the +255-volt regulator while the screen voltage is from the +105-volt regulator on the Type MP chassis.

**CRYSTAL OSCILLATORS.** Two plug-in crystal oscillator units are provided on the Type

MP Frequency Stabilizer chassis. The CRYSTAL OSCILLATOR SELECTOR switch S-301 selects the unit in use, either the No. 1 unit towards the front of the chassis or the No. 2 unit behind it.

The crystal oscillator generates the reference signal that is compared with the output of the oscillator-tripler grid circuit to instigate the frequency stabilizing action. Each crystal unit consists of a type 1614 oscillator-doubler tube, a Bliley TC92 plug-in crystal unit with a built-in Westinghouse thermostat, two tank circuits and associated components.

The thermostats in the crystal oven will maintain the crystal temperature within  $\pm 1^\circ$  C. at any ambient temperature between  $-20^\circ$  C. and  $+65^\circ$ . The frequency stability of the unit is in the order of  $\pm .0005$  percent or better after the oven has reached its operating temperature. 6.3 volts a-c are provided for operation of the crystal oven heaters from transformer T-721 in the cubicle. Three indicator lights are provided on the control panel to indicate performance of the crystal oscillators. I-708 is the CRYSTAL HEATER POWER indicator that shows when power is applied to the heaters. I-709 and I-719 are the CRYSTAL HEATER NO. 1 and NO. 2 indicator lights. These two lights are operated by the thermostatic switches, and they flash on and off to indicate operation of the thermostats.

The unit employs conventional double-tuned electron-coupled oscillator circuit. L-401 and C-405 are tuned to the fundamental crystal frequency, or to  $1/18$  the transmitter output frequency. This tank circuit, together with the grid, screen and cathode form a conventional triode crystal oscillator. L-402 and C-406 form a tank circuit for the plate of the tube. It is tuned to twice the crystal frequency.

C-401 is a small capacitor connected in parallel with the crystal that can be employed to adjust the frequency over a narrow range to compensate for circuit capacity and inductance. This adjustment is made at the factory before shipment of the units. Since the entire range of this adjustment is well within the permitted frequency operating tolerances, it will probably never need to be made at the station when tubes are changed.

Cathode current from the oscillator in use is read on the CRYSTAL OSCILLATOR CATHODE CURRENT meter, M-301 on the front panel of the Type MP unit. The crystal oscillator may be tuned by reference to this meter by adjusting the screw-driver-operated controls on the chassis of each crystal unit.

Power for the oscillator units is supplied by the  $+105$  volt regulator on the Type MP chassis.

PHASE SHIFT NETWORKS. The output of the crystal oscillator unit is at  $1/9$  the carrier frequency. It is applied to two mixer tubes, the #1 mixer V-302 and the #2 mixer V-307 through two

resistance-capacity phase shift networks. The output to the #1 mixer is advanced approximately  $45^\circ$  in phase due to the positive reactance of C-308 and R-304 while the output to mixer #2 is retarded approximately  $45^\circ$  in phase by the negative reactance of R-329 and C-338. C-339 acts as a capacitive divider of the crystal oscillator output but does not play a part in the phase-shift networks. As a result of the phase shift networks two quadrature voltages (approximately  $90^\circ$  out of phase) are applied to the two mixer stages.

#1 MIXER STAGE. The #1 mixer is comprised of the type 6SA7 tube V-302 and its associated components. The signal from the oscillator-tripler grid circuit, amplified by the buffer amplifier is supplied to the control grid of the tube while the  $+45^\circ$  voltage from the crystal oscillator is supplied to the mixer grid. The output of the mixer is a frequency representative of the difference between the two frequencies. The higher frequencies derived from the mixing are bypassed to ground by C-310.

#2 MIXER STAGE. The #2 mixer is similar to the #1 mixer. It is comprised of the type 6SA7 tube V-307 and its associated components. The signal from the buffer-tripler grid circuit and the  $-45^\circ$  voltage from the crystal oscillator are mixed to provide an output at the identical frequency provided by the #1 mixer. However, the *phase* of the output of the #2 mixer will differ from that of the #1 mixer by  $90^\circ$  due to the phase difference in the crystal oscillator voltages provided by the phase shift networks.

RELATIONSHIP BETWEEN MIXER OUTPUTS. The phase relationship between the two mixer outputs is very important in the operation of the frequency stabilizing circuits. Three possible conditions can exist. These are:

1. When the frequency of the oscillator-tripler grid circuit is the same as the frequency from the crystal oscillator, there will be no output from the mixers.
2. When the frequency from the oscillator-tripler grid circuit is higher than the crystal reference frequency, the output of the #2 mixer will lead the output of the #1 mixer by  $90^\circ$ .
3. When the frequency from the oscillator-tripler grid circuit is lower than the crystal frequency, the output of the #2 mixer will lag the output of the #1 mixer by  $90^\circ$ .

Since, during the positive part of a single audio frequency cycle, the carrier will shift in the low-frequency direction, the output of the #1 mixer will lead the #2 mixer during this half of the cycle. During the negative part of the audio cycle, the frequency excursion will be in the high frequency direction and the output of mixer #2 will lead.

It should also be noted that, under linear modulation conditions, the time duration of the positive part of the audio cycle and of the negative part of the cycle will be equal. Also, the amplitudes of the two parts of the audio cycle are equal, making the limit of the frequency excursion equal in both directions.

Thus, during one complete audio cycle, it can be seen that the phase of mixer #2 will lead mixer #1 for half the cycle and lag it for the other half, and that the two periods will be of equal time duration. Also that when the output is linear and the two frequency excursions are equal in both directions, the number of cycles in the mixer output will also be equal during the positive and negative parts of the audio cycle.

However, when the frequency excursion in one direction from the reference frequency is greater than in the other, the frequency from the mixers *will not be equal during the two halves of the modulation cycle*. Such a condition occurs when the center frequency of the oscillator-tripler differs from the crystal oscillator frequency.

It is necessary to understand these relationships thoroughly in order to follow the explanation of the circuits that follow.

**MIXER AMPLIFIERS.** The type 6SN7 double triode tube V-303 is used to amplify the output of both mixers. The section comprised of grid 1, plate 2 and cathode 3 acts as a cathode-biased amplifier for the #2 mixer. Its output is employed to trigger the multivibrator V-304.

The other section of the amplifier is used to amplify the output of the #1 mixer. This section is biased practically to cutoff, and acts similarly to a square wave generator. A few volts of drive in the negative direction will drive the grid to cut-off, causing the plate voltage to rise rapidly, level off at the maximum supply voltage, and fall almost vertically when the grid is driven positive again.

On the positive half of the driving cycle, the grid draws grid current and a squaring effect will also be developed. However, only the positive cycle at the plate of the tube is employed in the circuits that follow. Consequently, the waveform of the negative part of the cycle is of no importance.

The output of the second section of the amplifier is applied to the pulse discriminator V-308.

**MULTIVIBRATOR STAGE.** The multivibrator transforms the amplified output of the #2 mixer into a series of square waves that are used to generate the narrow pulses employed by the pulse discriminator. It consists of the type 6SN7 tube V-304 and its associated components shown on Fig. 6-4.

The multivibrator is designed to turn over very rapidly, and the voltage at its plates will be essen-

tially square waves, appearing at the frequency and with the phase relationship of the #2 mixer.

The output from one of the plates is differentiated by C-318 and applied to one side of the pulse discriminator while the output of the other plate is differentiated by C-319 and applied to the other side. The values of C-318 and C-319 are such that the outputs to the discriminator appear as a series of sharp voltage spikes of opposite polarity.

**PULSE DISCRIMINATOR.** The pulse discriminator combines the output of the multivibrator with the amplified output from the #1 mixer in such a manner that voltage spikes appear in one side of its circuit when the oscillator-tripler frequency is above that of the crystal oscillator and in the other side, when the oscillator-tripler frequency is lower than the crystal frequency.

The pulse discriminator is comprised of the type 6H6 double diode tube V-308 and its associated components. A simplified schematic diagram of the essential elements of this circuit is shown in Fig. 3-3, while its action can be seen in the waveform diagram, Fig. 3-4.

It will be noted that Fig. 3-4 shows the development of the voltages applied to the discriminator by the earlier stages. The row of waveforms down the left hand side of the drawing indicates the conditions in the circuits during one half of the modulation cycle while the right hand column shows conditions in the other half of the cycle.

The dotted line dividing each column of waveforms separates the waveforms appearing on one side of the discriminator from those on the other.

The output of the #1 mixer as it is applied to *both* of the plates of the discriminator tube is shown by waveform 5. The voltage spikes from the multivibrator will be seen to be 180° out of phase on the two sides of the discriminator.

The phase relationship between the #2 mixer (waveforms 2 to 4) and the output of the #1 mixer can be seen by reference to Fig. 3-4. It should be noted that this relationship changes between the positive and negative half of the modulation cycle, as shown in the left hand and right hand columns of Fig. 3-4.

The cathodes of the discriminator tube have been biased to +255 volts by connection to the d-c regulated supply through isolating resistor R-334. This means that signals of less than this value cannot cause the diode to pass current.

It should be noted that the maximum possible voltage available from the amplified output of the #1 mixer will also be +255 volts since its plate supply is also of that same value. Consequently any voltage due solely to the #1 mixer output cannot cause the discriminator to pass current. Since the voltage spikes from the multivibrator are also

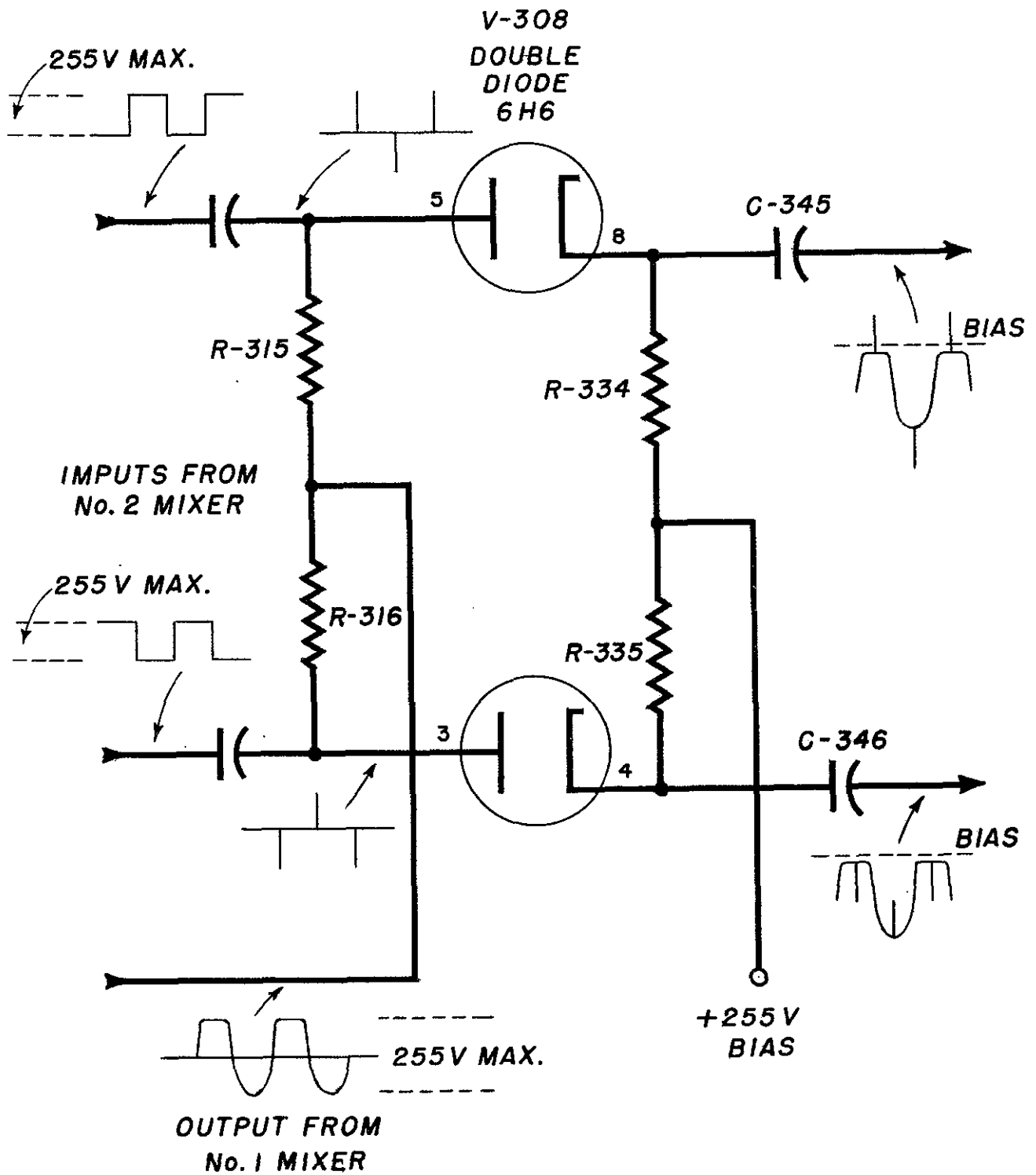

Figure 3-3—Pulse Discriminator, Simplified Schematic Diagram



limited to the same voltage for the same reason, they alone cannot operate the discriminator.

Consequently, the discriminator can only pass current when the two voltages appear coincidentally in a positive direction, and therefore add together to produce a voltage greater than the bias applied to the cathodes of the discriminator tube. Therefore, it can be seen that the discriminator will only operate when the phase relationships of the output voltage from the two mixers are such that they will add together.

Waveform 6 on Fig. 3-4 shows how the two outputs will add on one side of the discriminator when one mixer output leads, and on the other side of the discriminator when it lags the output of the other mixer.

Thus, the function of the discriminator is to produce positive spikes of voltage in one of its outputs when the output frequency is above the center frequency of the station, and on the other side when the output frequency is below it. It can also be seen that more pulses will be produced in one side than in the other if the frequency excursions from the center frequency are of unequal amplitude.

**PULSE AMPLIFIER.** The pulse amplifier amplifies the output of both sides of the pulse discriminator and applies its outputs to the pulse integrator stage across a pulse limiter. This stage consists of the type 6SL7 double triode V-309. The tube actually forms two triode voltage amplifiers, one amplifying each side of the discriminator output. A limiting action is inherent in the stage due to the fact that its cathode is established at a fixed positive cut-off bias through the action of a voltage divider formed by resistors R-342, R-339 and the cathode resistor R-337. Since the tube is driven from cut-off to saturation, the amplitude of the pulses is limited in a *positive* direction by the cathode bias. And since the cathode resistor is common to both sides, and the plate resistors equal, the output of the two sides will be equal despite small differences in the driving voltages.

**PULSE LIMITER.** The pulse limiter is employed to limit the pulses in a negative direction following the appearance of the positive pulses in the plate circuit of the amplifier. It also prevents any overshoot that could be caused by stray inductance in the circuits. The pulse limiter consists of the dual diode type 6H6 tube V-310.

The plates of the tube are connected to a voltage more positive than the cathode of the amplifier, yet lower than the amplifier plate voltage. One of the cathodes of the diode is connected to each of the plates of the amplifier. Under normal conditions, this would place the plates at a lower voltage than the cathodes, and the tube sections would not pass current.

However, following each pulse, there is a tendency for the voltage to fall below the level of the voltage on the diode cathodes. When this takes place, it would place the cathodes of the diode at a lower potential than the plates, and thus would cause the diode to pass current and act as a short circuit while this condition exists. Since the excess negative voltage would then discharge through the diode, it can be seen that the pulse limiter will therefore prevent the plate voltage from ever going lower than the voltage on the diode plates and will therefore produce a limiting action against voltage excursions in a negative direction.

**PULSE INTEGRATOR.** The pulse integrator receives the positive pulses from both sides of the pulse discriminator after they have been amplified and limited. It applies them as current pulses in a positive or negative direction, to an integrator storage capacitor that determines the value of the automatic frequency control voltage to the modulator control tube.

A simplified schematic diagram of this circuit is shown in Fig. 3-5. It consists of the two type 6H6 dual diode tubes V-311 and V-312 connected as shown in this diagram. The cathode follower is also included in the diagram since it plays an important part in the action of the circuit.

Due to the characteristics of the type 6SL7 cathode follower tube, the voltage at the cathode will always be three volts positive to the voltage at the grid. Due to the value of the cathode resistors R-343 and R-344 and the other cathode resistors, the voltage at the lower end of R-344 will always be approximately 6 volts less than the voltage at the cathode. This will establish the voltage at the positive end of the integrator as 3 volts above the grid voltage and at the negative end as 3 volts below it.

Since the grid voltage will always be determined by the charge on the integrator capacitor C-352, it can be seen that the entire circuit will always maintain a condition where the high side is 3 volts above the voltage on the integrator capacitor and where the negative side will be 3 volts below it.

When a negative voltage pulse appears at point A in Fig. 3-5 it is differentiated into two pulses, one positive and one negative as shown by waveform 8 on Fig. 3-4. The negative pulse, applied to cathode 4 of V-312 will cause the cathode to become negative to the plate and current will flow through the diode into the integrator capacitor C-352, adding to the charge on it. The positive pulse, applied to the cathode 4 of V-311 will only make the cathode more positive and the tube will remain blocked. However, it will be simultaneously applied to the plate 3 of V-311 making it more positive than cathode 4.

Since cathode 4 is established at essentially the same voltage as the plate by resistor R-327, the

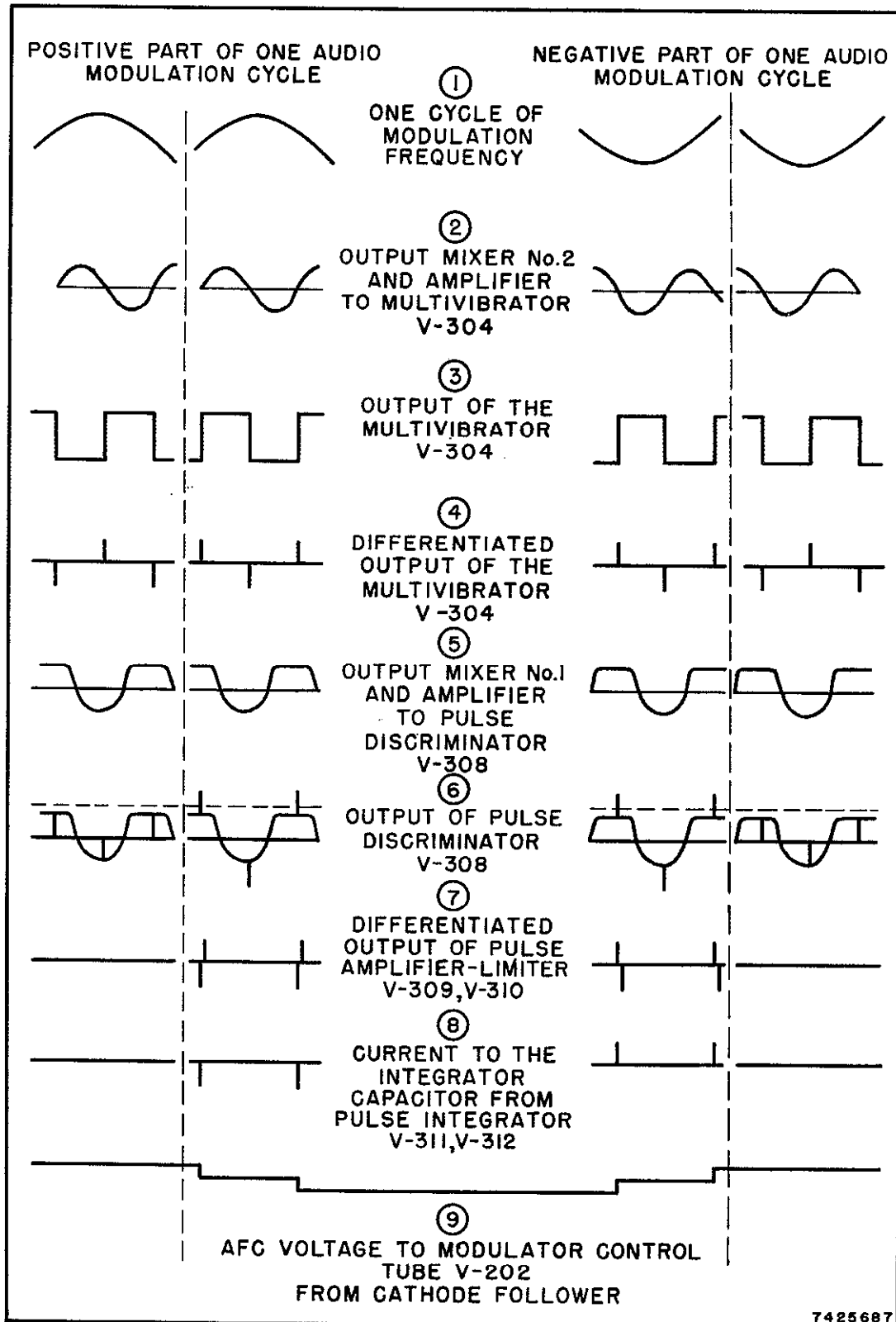

Figure 3-4—Waveforms of Frequency Stabilizing Circuits

positive pulse will be passed to ground through C-351 and will not appear at the integrator capacitor.

A corresponding effect is noted when pulses appear at point B, though with the opposite effect on the charge on the integrator capacitor. A negative pulse at B will also be differentiated into a positive and a negative pulse. When the negative pulse is applied to plate 5 of V-311, it simply makes the plate more negative than the cathode and no current is passed through the tube to the integrator. However, this same pulse, applied to cathode 8 of V-312 will make the cathode negative to the plate and the pulse will be short-circuited through the tube and C-350 to ground. The positive pulse, however, when applied to plate 5 of V-311 will make that plate positive to the cathode. Current will therefore flow from the cathode to the plate. This will serve to discharge the capacitor C-352 through the tube.

Thus it will be seen that a positive pulse on one side of the integrator circuit will add to the charge on the integrator capacitor while a positive pulse on the other will discharge it.

Since the pulses are very narrow due to the differentiating capacitors in the circuit, each pulse will add very little current to the integrator capacitor and will, therefore cause only a small variation in its charge.

Therefore, the automatic frequency control to the modulator control tube will be varied in only small steps by the action of the circuit when the center carrier frequency and the reference frequency are close. However, when any considerable degree of variation occurs, many more pulses will be added in one direction than in the other, and the variation necessary to correct the frequency will be quite rapid.

**CATHODE FOLLOWER.** The cathode follower stage is comprised of the type 6SL7 dual triode tube V-313. Its two triode sections form two cathode followers. The grids of both sections are connected to the integrator capacitor, and consequently the level of the voltage at the cathode is established by the charge on this capacitor.

One section of the cathode follower serves to establish the voltages across the pulse integrator tubes as was explained in the description of that circuit. R-345, the DIODE BIAS control on the front panel of the Type MP unit provides a means of adjusting these voltages to proper operating conditions.

The other cathode follower section acts to provide the automatic frequency control voltage to the modulator control tube so as to establish the proper center frequency for the transmitter output. The voltage at the cathode of this section is directly connected to the grid of the modulator control tube,

providing operating bias for it and establishing the current through the modulator.

**FREQUENCY CONTROL SWITCH.** The frequency control provided by the stabilizer circuits may be removed by operating the FREQUENCY CONTROL switch S-302 to the OFF position. This disconnects the integrator capacitor from the pulse integrator and connects it to the center point of resistors R-343 and R-344. The charge on the capacitor, and therefore the value of the automatic frequency control voltage is then established by the voltage existing at this point. This connection is only used when tuning up the transmitter as it permits a reference level to be established where the proper value of current through the modulator tube may be secured.

Extra contacts on this switch break an interlock circuit to the high voltage rectifiers in the cubicle and prevent the application of power to the driver and power amplifier unless frequency stabilization is being provided. Another set of contacts operates indicator light I-301 to indicate the position of the switch.

**FREQUENCY CONTROL INDICATOR LIGHT.** The frequency control indicator light is included to show when the stabilizing circuits are actually controlling the frequency. It is comprised of the neon indicator light I-302, the BEAT INDICATOR light on the front panel of the Type MP Stabilizer unit.

The indicator light is connected between the plate of the #1 mixer amplifier and the 255 V. Supply Limiting resistor R-325 limits the current through it.

When the stabilizing circuits are controlling the frequency, the voltage difference between these two points is sufficient to start the neon light. The voltage drop through R-325 will be sufficient to extinguish it as soon as current starts to flow, so the light will flash on and off to indicate that the frequency control circuits are operative.

**VOLTAGE SUPPLY CIRCUITS.** Filament supply for all of the tubes on the type MP unit is provided from the cubicle, as is the 400-volt d-c supply. Two voltage regulators for the d-c supply are located on the chassis. These are the OC3/VR-105 tube V-317 and the OD3/VR-150 tube V-316. These two tubes are connected in series to provide both +255-volt and +105-volt regulated d-c power from the 400 volt supply.

A bias rectifier with a regulated output of -105 volts is located on the Type MP chassis. This rectifier is comprised of transformer T-301, the type 6X5GT/G tube V-314, filter capacitors C-353 and C-354 and filter resistor R-350. Its output is regulated by the type OC3/VR-105 tube V-315 and dropping resistor R-351.

Figure 3-5—Pulse Integrator, Simplified Schematic Diagram

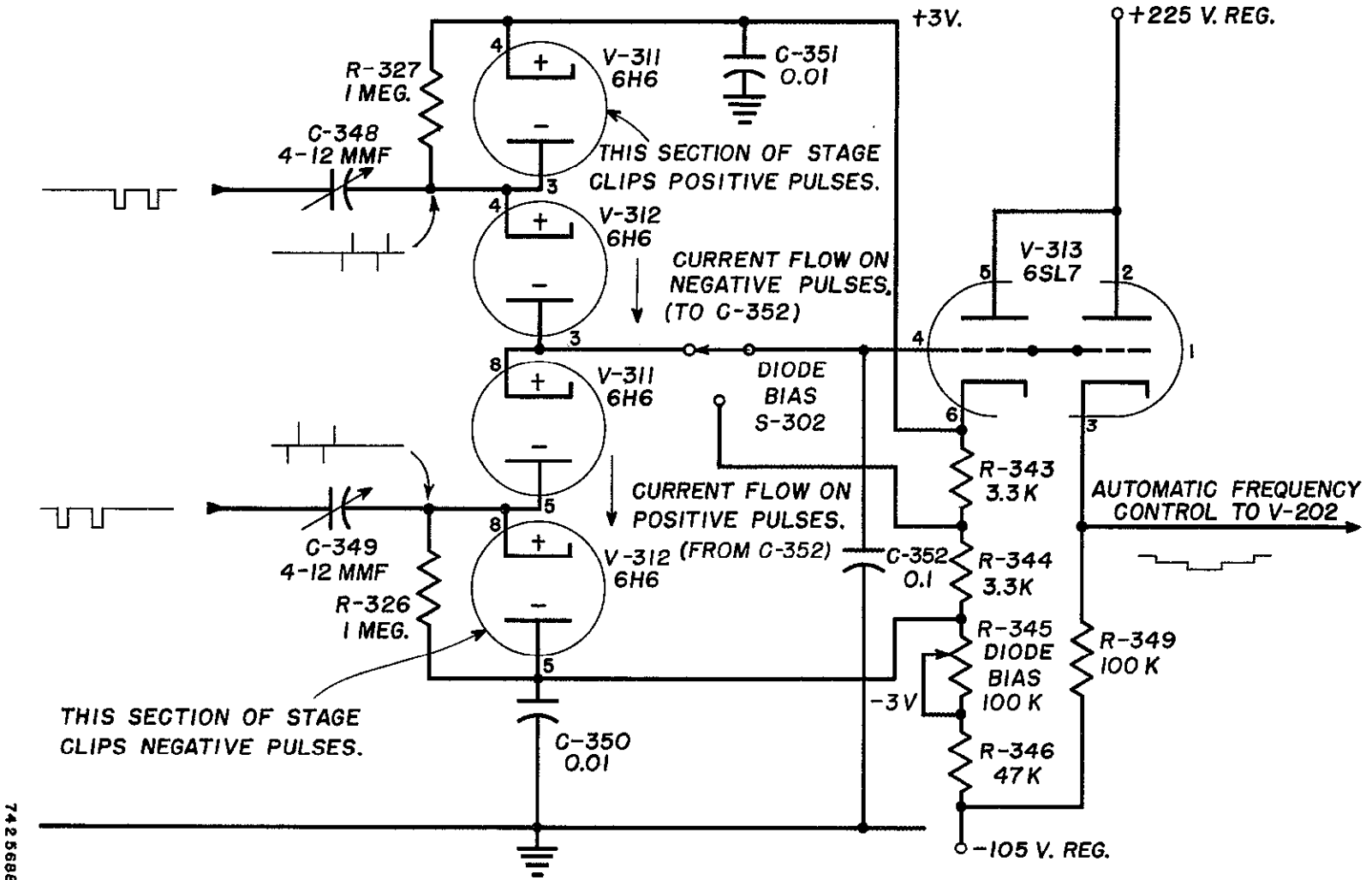

### Radio Frequency Amplifying Circuits

The radio frequency amplifying circuits are comprised of a driver stage consisting of two type WL5D22/4-250A tubes and a 3 kilowatt amplifier employing two type WL473 tubes. The grid and plate circuits of the driver and the plate circuit and loading circuit of the amplifier are operated by motor-driven tuning units controlled by switches on the control panel of the transmitter.

**DRIVER STAGE.** The driver is a push-pull class C radio frequency amplifier stage employing two type WL5D22/4-250A tubes. It is excited by the output of the Type MO Frequency Modulated Oscillator and its output drives the power amplifier stage.

The grid circuit is composed of the grid inductance L-715 and is tuned by the motor-driven capacitor C-701. Excitation is applied to the grid circuit through a coaxial line from Type MO unit to coupling link L-714. C-702, in series with the coaxial line, is included so that the excitation to the stage may be adjusted.

Grid current is indicated by the DRIVER GRID CURRENT meter M-703 while the plate current is shown by the DRIVER PLATE CURRENT meter M-704. These meters are located in the row of meters near the top of the cubicle.

Grid bias is provided by grid resistor R-709. The driver excitation relay K-706 is located in the grid circuit to prevent application of high voltage to the driver and amplifier unless proper excitation is present, and this relay must close to complete the high voltage control circuit. If excitation fails, or falls below proper value, this relay will open and shut down the high voltage supply.

Overload relay K-707 in the cathode return circuit provides similar protection in case of an overload in the stage.

A linear tank circuit comprised of L-716 tuned by C-703 is employed in the plate circuit of the driver. C-703 is driven by a tuning motor operated by the DRIVER PLATE TUNING switch on the control panel. An adjustable shorting bar is used to tune the tank roughly to the operating frequency. A pickup loop and a coaxial line couples the output to the cathode tank of the 3 kilowatt amplifier.

The two type WL5D22/4-250A tubes are neutralized by neutralizing capacitor C-705 in the screen circuits, a conventional method of neutralizing these tubes at high frequencies. The capacitor is a two-section unit, one adjustment serving to neutralize both tubes.

Plate power is supplied by the high voltage rectifier in the cubicle. Dropping resistors R-712, R-713, R-714 and R-715 are employed to lower the screen voltage to its proper operating value.

**3 KILOWATT AMPLIFIER STAGE.** This

stage amplifies the output of the driver to provide the 3 kilowatt output of the transmitter into a 51.5-ohm transmission line. The plate tuning and output coupling adjustments are motor-driven, being controlled by switches on the control panel.

The power amplifier consists of two type WL473 tubes connected in a push-pull grounded-grid, cathode-driven class C amplifier.

Excitation to the power amplifier is supplied by the pickup loop and coaxial line previously described in connection with the driver stage. The termination of this line is tapped directly onto the elements of the linear cathode tank L-718. The tank is tuned by a shorting bar, but this adjustment is not critical.

Filament power is supplied to the tubes through the hollow cathode lines from transformers T-714 and T-715. These transformers are Scott-connected to provide a single-phase output from the three-phase supply.

Two grid series capacitors, C-707 and C-708, are employed to neutralize the stage.

The 3 kilowatt amplifier excitation undervoltage relay K-708 is connected in series with the grid return circuit. Its contacts short out resistor R-720 in the cathode return circuit when sufficient excitation is present for normal operation. When the excitation drops below the proper value, these contacts open and place the resistor in the cathode circuit, providing extra protective bias to prevent damage to the tubes. Individual overload relays are provided for each tube. An overload in one of the tubes will cause either K-709 or K-710 to operate, removing the high voltage by opening the high voltage interlock control circuit by operating the master overload relay K-721.

The 3 KILOWATT AMPLIFIER GRID CURRENT meter M-705 is included in the grid circuit to indicate grid current and the 3 KILOWATT AMPLIFIER PLATE CURRENT meter M-706 is in the cathode circuit to indicate plate current through the tubes.

The plate inductance consists of the linear tank circuit L-719. A shorting bar is provided to tune the tank to the approximate frequency while the motor-driven tuning capacitor C-704 provides for fine adjustments by operating the switch on the control panel. The motor-driven link L-720 is employed to couple the output of the amplifier to a 51.5-ohm line. This link is adjusted by operating a switch on the control panel. A small r-f voltage is also coupled from the tank circuit for operation of the station monitor by a small pickup loop and an RG-8/U cable.

**R-F VOLTMETER RECTIFIER.** This circuit is located near the output coupler on the 51.5-ohm transmission line. It consists, essentially, of a capacity voltage divider across the line formed by

C-501, C-502 and C-503 and the type 9006 diode rectifier. The output of the rectifier is supplied to the TRANSMISSION LINE VOLTAGE meter M-709 to provide an indication of the voltage present on the transmission line.

#### D-C Rectifier Circuits

Two vacuum tube rectifiers in the cubicle provide the d-c plate and screen voltages for all of the tubes in the transmitter. An additional rectifier in the Type MP Voltage Stabilizer provides a -105-volt negative voltage for bias required by the tubes in this unit. Two Rectox rectifier circuits are also located in the cubicle but since they operate in conjunction with the motor-driven tuning circuits, they will be more fully described under that heading.

**LOW VOLTAGE RECTIFIER.** The low voltage rectifier provides an output of +400 volts  $\pm$  20 volts that is required for operation of the Type MO and Type MP units. The components of this circuit are transformers T-704 and T-705, the type 866A rectifier tubes V-701 and V-702, filter reactors L-701 and L-702 and filter capacitors C-713 to C-719, inclusive. These are connected in a full-wave rectifier circuit as shown on Fig. 6-2.

The reason for the large value of capacity in the filter is to establish the very low noise level of the transmitter. Satisfactory performance can be obtained with less capacity. Consequently, if one of these capacitors breaks down in service, it may simply be cut out of the circuit and the transmitter returned to the air without it. The capacitor should, of course, be replaced the next time the transmitter is shut down.

The output of the low voltage rectifier is supplied directly to the Type MO unit for operation of the tripler stage and the intermediate amplifier stage. Part of the rectifier output is also supplied to the voltage regulator in the cubicle that provides a regulated output of 275 volts for operation of the other stages in the Type MO unit.

The Type MP unit is provided with the +400-volt output of the rectifier. Two voltage regulator tubes in the Type MP unit provide a +255 and a +105 regulated voltage. These are used to supply the various tubes in the unit. A negative bias rectifier is included in the Type MP unit. This latter circuit has already been described in connection with frequency stabilizing circuits.

**2,500-VOLT RECTIFIER.** The 2,500-volt rectifier is comprised of the three-phase delta-connected transformer formed of the combination of T-701, T-702 and T-703, the motor driven regulator T-719, six type 872A tubes V-703 to V-708 inclusive and their filament transformers T-706 to T-711 inclusive.

The output of the rectifier is filtered by inductor L-703 and filter capacitors C-710, C-711 and C-712.

Three individual transformer units are used to form the plate supply transformer, connected in a closed delta connection. In case one section is defective, it may be removed completely, and the remaining two sections connected in an open delta connection and the transmitter operated at full power output while the defective section is being repaired or a replacement secured.

Three taps are provided on the voltage regulator Powerstat T-719 to permit operation on inputs of 208, 230 and 240 volts. When properly connected, the output of the regulator will provide for a voltage variation in the rectifier output of from zero to 3,000 volts.

Three resistors are provided, one in each of the leads from the regulator to the plate transformer. These are to prevent sudden application of full power to the transmitter by applying power initially through the resistors, Relay K-703, the step-start relay shorts out these resistors almost immediately power is applied to the circuit. This prevents a sudden surge through the rectifier tubes for the first few a-c cycles when power is applied.

The output of this rectifier is applied to the Driver and 3 Kilowatt Amplifier stages.

**CUBICLE VOLTAGE REGULATOR.** This circuit is comprised of the two type 6Y6G voltage regulator tubes V-601 and V-602, the type 6SJ7 regulator control tube V-603 and the type OC3/VR-105 regulator bias tube V-604 connected in a conventional electronic voltage regulator circuit.

Bias for the regulator control tube V-603 is adjusted by R-601 to provide an output of 275 volts d-c for the Type MO unit.

#### A-C Distribution and Control Circuits

The a-c distribution and control circuits are shown on Fig. 6-2, the schematic diagram. Two sources of 115-volt a-c are required. One of these is employed to operate the trouble light and the utility outlets within the cubicle as well as the fluorescent lights illuminating the meters along the top of the cubicle. This is normally connected to the lighting circuit of the transmitter room so that these facilities will be available whenever the transmitter room is being used. A second source of 115-volts a-c is also required to operate the crystal heater circuit. This source should be one that is present at all times, so that the crystal temperature may be maintained during night-time shut-downs.

**PRIMARY A-C CONTROL AND DISTRIBUTION CIRCUITS.** The transmitter is designed to operate on any line voltage between 204 and 240 volts, three-phase power from the mains. This is connected to terminal board TB-701. From this

terminal board, the power is run to the outside terminals of switches S-701 and S-702, the main breakers in the compartment below the control panel on the front of the cubicle.

S-702 is a thermal type overload breaker that will open whenever an overload occurs. However, due to the thermal characteristics of the breaker, a slight delay is inherent in its operation and it will not open on sudden surges.

When S-701 is placed in the ON position, voltage is applied to the following points:

1. The blower motor B-701, that will start immediately.
2. The control circuits for excitation of the relays and contactors to turn on the remaining circuits.
3. The switches controlling the motors driving the tuning elements and the voltage regulators.
4. The supervisory relay circuit.
5. The distribution bus voltage regulator T-718.

The output of the distribution bus voltage regulator is applied to the following points:

1. The taps on the BUS VOLTAGE switch S-738. This switch permits the BUS VOLTAGE meter M-701 to be switched so as to measure the voltage on all three phases of the distribution bus and also one phase of the supply to the 2,500-volt rectifier.
2. The Line contacts of contactor K-703, the filament contactor.
3. The Line contacts of K-704, the 400-volt rectifier contactor.

**APPLYING FILAMENT VOLTAGE.** After a-c power has been applied to the distribution bus regulator, and the voltage adjusted to 230 volts d-c as indicated on the BUS VOLTAGE meter, the filaments may be turned on by operating the FILAMENT POWER SWITCH S-703 if the following interlock requirements have been met:

1. The blower motor is supplying air to the distribution system and air relay S-727 has closed. This will be indicated by operation of the AIR INTERLOCK indicator light I-701.
2. The interlocked doors must be closed, completing the circuit necessary to operate the door interlock relay K-720. This will be indicated by the operation of the DOOR INTERLOCK indicator light I-715.

Switch S-703 may then be operated. This will immediately light the READY indicator light, and if the interlock conditions are satisfactory, will also light the ON light and close contactor K-703 applying voltage to all of the filament transformers in the transmitter. It will also start the time delay relay K-705 that has its contacts in the interlock

circuit of the 400-volt rectifier control circuits, and will apply power to the TOTAL HOUR meter M-708. Power will also be applied to the Type MP unit to turn on its bias voltage supply.

A set of contacts on K-703 also closes to complete the interlock circuit to the 400-volt rectifier contactor permitting this circuit to be turned on after other interlock conditions have been met.

**TURNING ON THE 400-VOLT RECTIFIER.** The 400-volt rectifier is turned on by operating the 400-VOLT RECT. switch S-704 after the following interlock conditions are satisfied:

1. Time delay relay K-705 has completed its cycle and its contacts have closed.
2. The door interlock relay K-720 has closed.
3. The filament relay K-703 has closed.
4. The 400-volt overload relay K-712 has not operated.
5. Any external interlocks connected into this circuit have closed.

Operating S-703 will cause the READY indicator light to come on immediately, and if the above interlock requirements have been satisfied, the 400-volt rectifier contactor K-704 will close and the ON indicator light will light.

K-704 will apply power from the distribution bus to the primary of transformer T-704 in the 400-volt rectifier.

**TURNING ON THE 2,500-VOLT RECTIFIER.** The 2,500 volt rectifier is turned on by operating the 2500 VOLT RECTIFIER switch S-705, after the following interlock requirements have been met:

1. The main breaker S-701 has been turned on.
2. The FREQUENCY CONTROL switch in the Type MP unit is in the ON position.
3. The driver grid underload relay K-706 has closed due to sufficient excitation being present.
4. The master overload relay K-721 must be closed indicating that no overload condition exists in the driver or amplifier stage. The operation of this circuit will be explained later.
5. The 400-volt rectifier relay K-704 must be closed.

Operating S-705 will cause the READY indicator light to come on at once, and after the interlock conditions are satisfied K-701 will close applying power to the rectifier transformers through the voltage regulator.

When K-701 closes, K-702 is in an open condition. This relay shorts out the surge-preventing resistors in the line to the rectifier transformers. K-702 is operated by a set of contacts on K-701 and closes a short instant after it. This action shorts out the resistors and applies full power to the trans-

formers. However, this slight delay prevents a sudden surge of current through the rectifier tubes until the filter capacitors have charged up to their rated voltage.

**MASTER OVERLOAD CIRCUIT.** The master overload relay K-721 is normally open. It is caused to close whenever driver overload relay K-707 or the left or right amplifier overload relays K-709 or K-710 operate due to an overload at that point. When K-721 operates it opens the circuit to the 2,500 volt rectifier contactor K-701 removing power from that rectifier. The instant the overload condition clears, K-721 will again close, restarting the rectifier.

**AUXILIARY RELAY CIRCUITS.** Since the transmitter will return to the air immediately, some indication of where the overload occurred should be indicated to the operator. Five auxiliary relays are provided for this purpose. They are shown in the upper right hand corner of the schematic diagram Fig. 6-2.

It will be noticed that a set of contacts on each of the overload relays will complete the circuit to a coil of the corresponding supervisory relay when it operates. This will cause the supervisory relay to close, and light its associated indicator light. However, a set of contacts on the supervisory relay will also close and act as a holding circuit after the main overload relay has again opened.

This will keep the light burning until the operator puts it out by operating the **OVERLOAD INDICATOR RESET** button S-736, removing power from the supervisory relay coil. The supervisory relays, and the main relays with which they are associated, are:

<i>MAIN RELAY</i>	<i>SUPERVISORY INDICATOR</i>	
2,500-volt rect. OL.K-711	K-716	I-713
Rt. Amp. OL.K-710	K-715	I-712
Left Amp. OL.K-709	K-714	I-711
Driver OL.K-707	K-713	I-710
400-V. Rect. OL.K-717	K-712	I-714

Power for operating the supervisory overload

relays is 24 volts d-c supplied by the Rectox rectifier CR-701.

**MOTOR-DRIVEN CONTROL CIRCUITS.** Two motor-driven control circuits are provided to operate the two motor-driven voltage regulators in the transmitter and four are provided for the tuning and coupling circuits.

These circuits are shown on the schematic diagram. All of these circuits are equipped with limit switches to prevent over-running the maximum and minimum positions of the components they control. These controls operate from a-c provided by transformer T-720.

The operation of all these circuits is quite similar. The phase-splitting capacitors are so switched that the operation of the switch in one direction will cause the motor to run one way while the operation in the other direction will cause the motor to run the other way.

The motor-driven tuning units are similar to the regulator motor system, except that a d-c voltage from a small Rectox rectifier is supplied across the motor when the switches are in the center position. This voltage stops the motors instantly and prevents overshoot when tuning and the desired position has been reached.

The four tuning drives are also equipped to indicate the position of the elements they control. A potentiometer is connected to the drive shaft and controls a d-c current supplied to the tuning indicator meters so that they will indicate the position of the drive shaft. An additional screwdriver-operated potentiometer is provided in each circuit to adjust the meters for proper indications in their scales.

Provisions for operating the two voltage regulators from remotely located switches are shown on the schematic diagram. It will be noted that these are connected so that the switch on the cubicle will always have direct control of the action. When the cubicle switch is being operated, the remote switch is inoperative.



# PART FOUR

## MAINTENANCE AND TROUBLESHOOTING

### Maintenance

The maintenance procedures to be employed in the operation of the Type FM-3 Frequency Modulated Broadcast Transmitter are dependent, to a large extent, upon the practices of the individual station using the equipment. They will be determined largely by the on-the-air time of the station, the test periods permitted and upon the practices and preferences of the station engineers.

Consequently the information contained in the following paragraphs can be considered as suggestions of the manufacturer and their adaptation is dependent upon the station engineers.

### SAFETY PRECAUTIONS

CAREFULLY READ  
"WARNING"  
ON PAGE I

### Cleaning the Equipment

The transmitter room is usually one of the show places in the broadcast station, and consequently a regular procedure is generally followed for cleaning the outside of the equipment to enhance its appearance. However, the inside of the transmitter also needs its share of cleaning and attention.

The inside of the transmitter, due to the air cooling system, will usually require a thorough dusting and cleaning during the first few weeks of operation. This is due to the fact that many small particles of packing material, and dust and lint that settled inside the transmitter during installation will be agitated by the blower motor and settle at various points inside the cubicle.

Before cleaning the inside of the transmitter, allow it to stand a few hours after the blower motor has been cut off so as to permit the dust particles to settle. Then carefully dust off the interior of the cubicle, the tube compartments and the Type MO and MP units with a lint-free rag. A small jet of dry compressed air, if available, will be very convenient for blowing dust out of hard-to-reach corners and from such components as contactors, motors, etc.

### Checking Air Filter

Check the condition of the air filter located at the blower motor on the floor of the cubicle. The length of time before it needs replacement or cleaning will depend upon the amount of dust present in the transmitter room and the length of time the transmitter is on the air. Clogging of the air filter

will, however, reduce the amount of air supplied to the tubes and will, if serious, reduce the air supply sufficiently so that the air relay will not operate and it will not be possible to place the transmitter on the air.

Replace the filter with a similar unit when it becomes clogged. The filter is an Air Maze Type R-82 replacement type unit manufactured by the Air Maze Corporation and replacement units should be available from any distributor of air conditioning equipment.

If the filter is to be cleaned, the manufacturer's instructions for such cleaning should be strictly followed.

### Tube Replacements

Tube replacements, due to breakdowns or burn-outs, must usually be made quickly in order to prevent expensive off-the-air time. The driver, power amplifier and rectifier tubes can be quickly reached through the access windows in the front of the cubicle and provision is made for storing replacements for these tubes in the compartment to the right of the power amplifier stage behind the upper access window. Make certain that a spare tube for these stages is always present in the compartment ready for use when necessary.

A complete set of spare tubes for the Type MO and Type MP units should also be kept on hand.

The tubes in the transmitter are very conservatively operated, and full tube life should be expected from all of the tubes. The tube hour meter will make it possible for the station engineers to maintain a log of tube life and to replace the tubes near the end of their expected life. Tubes that do not carry serial numbers can be labelled or stamped for identification.

The tube characteristics of the various tubes in the Type MP unit, unlike those in other types of stabilizing circuits, are not important in determining the operation of the frequency stabilizing circuits. These tubes are operated from cut-off to saturation and, since no sharply tuned circuits are employed, the tube characteristics do not play a very important part in the operation of the circuits and full tube life may be expected. In most cases routine tube checks will cause the tube to be discarded long before any change in its characteristics will affect the operation of the circuits.

### Metal Rectifiers

During the first 2,000 to 3,000 hours of their life, a slight decrease in voltage may be noticed

from the Rectox metal rectifiers employed in the tuning motor circuit. This change in the metal rectifier employed in the braking circuit to the tuning motors will not be noticed. However, a slight change in the voltage of CR-701 may be noted since it will cause a slight difference in the reading of the tuning meters on the control panel. This can be corrected by adjusting the potentiometers located adjacent to the meters and behind the control panel.

After this initial period, the Rectox units will require no attention except for regular removal of dust particles from their cooling fins.

### Relay Adjustments

The following relay adjustments are proper for operation of the transmitter. Certain of these can be checked during the tune-up of the transmitter. However, checking others might place an undue load on some of the components.

Most of the relays are provided with adjusting scales and the indications of these scales may be used in making adjustments unless it is suspected that the indication is wrong. In that case it will be necessary to disconnect the relay and apply the proper type of current from an adjustable source in order to check the operation of the relay.

The following relays require adjustment:

RELAY	PURPOSE	ADJUSTMENT
K-706	Driver Excitation Underload	Close at 15 ma. d-c
K-707	Driver Overload	Open at 800 ma. d-c
K-708	3-Kw. Amp. Excitation Underload	Close at 50 ma. d-c
K-709	Rt. 3-Kw. Amp. Overload	Open at 1.5 amps. d-c
K-710	Left 3-Kw. Amp. Overload	Open at 1.5 amps. d-c
K-711	2,500 Volt Rect. Overload	Open at 3.5 amps. d-c
K-712	400 Volt Rect. Overload	Open at .6 amps. d-c

### Bliley TC92 Crystal Units

No regular maintenance is necessary on this unit beyond making certain that the plug-in contacts are corrosion-free and that the heater voltage is maintained within  $\pm 10$  per cent of the 6.3 volts a-c specified by the manufacturer. Transformer taps are provided for adjusting this voltage, on T-721. If any faults are disclosed during operation of this unit, it should be returned to the manufacturer, Bliley Electric Company, Union Station Building, Erie, Pennsylvania with all pertinent information necessary to assist the manufacturer to determine the cause of the trouble.

### Check of Meters

All meters, except the tuning meters, should be checked for zero indication with power off. If these meters are not properly zeroed, they may be ad-

justed by their adjusting screws. The tuning meters, due to the method employed in their alignment, will probably not indicate zero when the transmitter is turned off. However, they may be checked by operating the tuning mechanisms from maximum to minimum position. The meter should then indicate from 100 to zero with the power on. If these indications are not obtained, the method of adjustment is described in Part II of this instruction book.

### Troubleshooting Indications

The following trouble-shooting indications are provided in the form of a procedure designed to assist the operator in locating the more common troubles in the transmitter. They are based upon the alignment procedure given in Part II and this procedure should be followed until a proper indication cannot be obtained. The operator will then know that the trouble is probably in one of the components of the circuit it is not possible to align properly.

### Radio Frequency Generating Circuits

If it is not possible to secure the proper radio frequency output from the oscillator-tripler, the r-f tripler or the intermediate amplifier, the trouble can usually be isolated to the proper stage by the indications of the meters on the control panel. The tube in this stage should then be replaced. If proper results are not then secured, the stage should be circuit-checked to locate any defective components. A short-circuit in any of these stages will usually cause the low voltage supply overload relay to operate. Due to the fact that all meters are in the cathode or grid circuits, a short in any of the stages will not show up as excessive indication on the control panel meters.

### Audio Frequency and Modulating Circuits

The 400-volt supply to the Type MO unit may be disconnected by opening the lead from terminal 4 on TB-601. This will leave the audio, and modulator circuits and the oscillator-tripler operative since they are supplied by regulated voltage from the cubicle regulator.

The audio input circuits and the audio amplifier can be checked for proper operation with an oscilloscope. The modulator control tube may also be checked with an oscilloscope if the modulator tube is removed and a 1,000-ohm resistor clipped across the modulator socket in place of the modulator tube to complete the plate circuit. The oscillator-tripler tube V-205 should be removed during this test.

Improper action of these stages can be located by circuit-checking and the defective component replaced.

If, after the audio stages are determined to be operating properly, and the modulator tube is replaced, it is not possible to adjust the modulator current to the proper value, the automatic frequency control lead to the cathode follower in the Type MP Frequency Stabilizer should be checked for short circuits to ground. With all filaments turned off, the resistance from the grid of the modulator control tube to ground should be approximately 3.8 megohms.

With power turned on, and the cathode follower tube V-313 in the Type MP frequency stabilizer removed, a negative bias of -105 volts d-c should be present at the grid of the modulator control tube V-202. Either of these indications will show that the automatic frequency control circuit is not shorted.

If this circuit is complete, and it is not possible to secure proper current through the modulator, the circuits of the cathode follower V-313 should be checked.

#### Frequency Stabilizing Circuits

An Oscilloscope will be valuable in checking the operation of the frequency stabilizing circuits, and an observation of the various waveforms present when the unit is known to be operating properly will, if recorded, prove a valuable aid to the operator when checking for trouble.

**BUFFER AMPLIFIER.** The operation of the buffer amplifier can be checked by observation of the grid current on the MIXER GRID CURRENT meter M-302. If the amplifier is tuned to maximum mixer grid current, a reading of 5 ma. should be obtained. If the proper current is not obtained, replace both mixer tubes to eliminate possibility of a tube defect. If the value of current still is not obtained, circuit check the buffer amplifier circuit for defective parts.

**CRYSTAL OSCILLATORS.** The performance of the crystal oscillators may be checked by the reading on the CRYSTAL OSCILLATOR CATHODE CURRENT meter M-301. Switching from one oscillator to another should change this reading but little. If a normal condition is noted with one oscillator and not with the other this will indicate trouble in the unit giving the improper indication. If both units give improper indication, the voltages to the units should be checked and the output circuits to the mixture should also be checked for defective components.

**PHASING NETWORKS AND MIXERS.** The output of the mixers will determine the proper operation of the phasing circuits and the mixers themselves. This output, taken at the plates of the tubes can be applied to an oscilloscope. One output should be connected across the vertical plates and the other across the horizontal plates of the

oscilloscope. This should produce a 1:1 Lissajou figure since the two outputs should normally be 90° out of phase.

**AMPLIFIER.** The output of the amplifier V-303 may also be checked at its plate with the oscilloscope. The output on plate 5 should be a distorted sine wave with the positive part essentially a square wave and the negative part a ragged sine wave distorted by grid current flow at its larger negative amplitudes. The amplitude of the wave should be approximately 250 volts. When using the oscilloscope to read the output derived from either mixer, it may be triggered by the output of the other mixer. The FREQUENCY CONTROL can be turned OFF and the oscillator tuned by hand to produce a close beat with the crystal oscillator output. No modulation signal should be applied during this test. Since there is a 90° phase difference, it will be possible to place the whole of the pattern of the wave being observed on the screen. Also, since the repetition rate of the waves will be dependent upon the frequency deviation, this trigger method will aid in stabilizing the pattern.

The oscilloscope, when connected to plate 2 of V-303 should show a distorted sine wave, though not as seriously distorted as the wave on plate 5.

**MULTIVIBRATOR.** If a negative trigger is available on the oscilloscope, it should be used, and the oscilloscope may be triggered from the negative portion of the output of the #1 mixer without affecting the circuit operation since only one or two volts of the negative portion of this wave is employed to completely cut off the amplifier plate current.

The waveforms at the plates of the multivibrator will be conventional square patterns. Since the output is differentiated, the leading and trailing edges of the wave should be as steep as possible. Allowance should be made for the sloping effect the capacity of the oscilloscope and oscilloscope cables will give the pattern when observing it.

**PULSE DISCRIMINATOR.** The distorted square wave output of the #1 mixer and the positive and negative integrated pulses from the multivibrator should both be present on plates 3 and 5 of the pulse discriminator V-308. The multivibrator spikes alone can be observed if V-302 is removed from its socket, and the distorted wave derived from the #1 mixer can be seen alone if V-307 is removed. The oscilloscope can be self-synchronized for this test.

**PULSE INTEGRATOR.** The waveforms present at this stage will indicate proper operation of the amplifier and the limiters. A very low-capacity input should be used to the oscilloscope to prevent it from loading the circuits, and the oscilloscope self-synchronized at a slow sweep rate.

Negative voltage pulses should be observed at both cathodes 4 of V-312 and 5 of V-311 to indicate operation of the circuit. The number of pulses can be made to increase and decrease by operating the DIODE BIAS control R-345.

Connecting the oscilloscope from cathode 3 of V-313 and adjusting the oscilloscope for a slow sweep rate should show a series of small steps on the horizontal sweep if the oscilloscope has sufficient sensitivity. These steps should pile up to a peak and then drop down to a reference level. This action may be in either direction, and will vary in time

considerably and may be difficult to see. To check the action, give the DIODE BIAS control a sudden turn in either direction and an increased deviation will be noted on the sweep that will indicate stabilizing action is taking place.

#### **Radio Frequency Amplifier Stages**

The radio frequency amplifier stages are straightforward and meters are provided to check their operation. Improper indications on these meters will enable the operator to locate the trouble. A circuit check of the circuit **WITH POWER OFF** will indicate the defective components.

# PART FIVE

PARTS AND RECOMMENDED SPARE PARTS LIST							PER UNIT	RECOM'D SPARE PARTS LIST	MINIMUM SPARE PARTS LIST
CIRCUIT SYMBOL	FUNCTION	DESCRIPTION	STYLE OR CAT. NO.	MFG.	WESTINGHOUSE DRAWING NO.	QUANTITY			
<b>AMPLIFIER-RECTIFIER</b>									
B-701	Motor-Blower	3/0 Utility Blower—7" Dia. Multivane Wheel Clockwise Rotation 1/4 Hp., 1725 Rpm., 220 V., 60 Cy., 3 Phase Motor, S# 1177179.		1	7616532 PT-1	1			
B-702	Motor-Driver Grid Tuning	115 V., 60 Cy. Gear Reduction to 1 Rpm. Comp. with 1 Mfd. Capacitor	Type 2505	16	7616532 PT-2	4	1		
B-703	Motor-Driver Plate Tuning	Same as B-702			7616532 PT-3				
B-705	Motor-P.A. Plate Tuning	Same as B-702			7616532 PT-5				
B-706	Motor-P.A. Output Coupling	Same as B-702			7616532 PT-6				
B-707	Motor-Fil. Bus Regulator Drive	Part of T-718			7616532 PT-7				
B-708	Motor-H.V. Rectifier Regulator Drive	Part of T-719			7616532 PT-8				
<b>TYPE MO UNIT</b>									
C-201	Capacitor-Suppressor	.0022 Mfd., 500 V. Mica	JAN-C-5 CM35B222K		7616695 PT-1	1	1	1	
*C-202	Capacitor-Pre-Emphasis Time Constant	330 Mmfd., 500 V. Mica	S# 1353120	1	7616695 PT-2	4	1	1	
C-203	Capacitor-Feedback Coupling	.5 Mfd., 600 V. Paper	JAN-C-25 CP29A1EF504K		7616695 PT-3	1	1	1	
*C-204	Capacitor-Heater By-Pass	.0056 Mfd., 500 V. Mica	S# 1353130	1	7616695 PT-4	3	1	1	
C-205	Capacitor-Heater By-Pass	Same as C-204			7616695 PT-5				
C-206	Capacitor-Heater By-Pass	Same as C-204			7616695 PT-6				
C-207	Capacitor-Modulator By-Pass	560 Mmfd., 500 V. Mica	S# 1471079	1	7616695 PT-7	1	1	1	
*C-208	Capacitor-Disc. By-Pass	100 Mmfd., 500 V. Mica	JAN-C-5 CM25D101K		7616695 PT-8	2	1	1	
C-209	Capacitor-Disc. By-Pass	Same as C-208			7616695 PT-9				
C-210	Capacitor-Modulator R.F. Coupling	5 Mmfd., 500 V. Ceramic	JAN-C-20 CC20CG050G		7616695 PT-10	1	1	1	
*C-211	Capacitor-Disc. Meter By-Pass	.01 Mfd., 600 V. Mica	S# 1353142	1	7616695 PT-11	5	1	1	
C-212	Capacitor-Disc. Meter By-Pass	Same as C-211			7616695 PT-12				
*C-213	Capacitor-Disc. R.F. Return	.01 Mfd., 300 V. Mica	S# 1353133	1	7616695 PT-13	10	2	1	
C-214	Capacitor-Disc. R.F. Coupling	27 Mmfd., 500 V. Mica	JAN-C-5 CM25B270M		7616695 PT-14	1	1	1	
*C-215	Capacitor-Oscillator Grid Tuning	15 Mmfd./Section, Variable	HFD-15-X	4	7616695 PT-15	2			
*C-216	Capacitor-Oscillator Grid Trimmer	10 Mmfd./Section, Variable, (All but 3 Plates per Section Removed)	HFD-15-X	4	7616695 PT-16	4			
C-217	Capacitor-Oscillator Grid Divider	5 Mmfd., 500 V. Ceramic	JAN-C-20 CC20PH050G		7616695 PT-17	1	1	1	
C-218	Capacitor-Oscillator Grid Divider	47 Mmfd., 500 V. Ceramic	JAN-C-20 CC20SL470J		7616695 PT-18	1	1	1	
C-219	Capacitor-Oscillator Grid	510 Mmfd., 500 V. Ceramic	JAN-C-20 CC40SL511K		7616695 PT-19	1	1	1	
C-220	Capacitor-Oscillator S.G. By-Pass	.0082 Mfd., 300 V. Mica	S# 1353132	1	7616695 PT-20	1	1	1	

PARTS AND RECOMMENDED SPARE PARTS LIST						PER UNIT	RECOM'D SPARE PARTS LIST	MINIMUM SPARE PARTS LIST
CIRCUIT SYMBOL	FUNCTION	DESCRIPTION	STYLE OR CAT. NO.	MFG.	WESTINGHOUSE DRAWING NO.			
C-221	Capacitor-Oscillator Heater By-Pass	Same as C-213			7616695 PT-21			
C-222	Capacitor-Audio Heater By-Pass	Same as C-213			7616695 PT-22			
*C-223	Capacitor-Tripler Grid Tuning	30 Mmfd./Section, Variable	HFD-30-X	4	7616695 PT-23	2		
C-224	Capacitor-Tripler Grid Trimmer	Same as C-216			7616695 PT-24			
C-225	Capacitor-Tripler Cathode Decoupling	510 Mmfd., 500 V. Mica	JAN-C-5 CM-25D511J		7616695 PT-25	1	1	1
C-226	Capacitor-Tripler Plate Tuning	Same as C-223			7616695 PT-26			
C-227	Capacitor-Tripler Plate Trimmer	Same as C-216			7616695 PT-27			
*C-228	Capacitor-Tripler Plate Decoupling	330 Mmfd., 500 V. Mica	JAN-C-5 CM25D331K		7616695 PT-28	2	1	1
*C-229	Capacitor-Intermed. Amp. Grid Coupling	27 Mmfd., 1500 V., Ceramicon	Type 850AB	29	7616695 PT-29	2	1	1
C-230	Capacitor-Intermed. Amp. Grid By-Pass	Same as C-229			7616695 PT-30			
C-231	Capacitor-Intermed. Amp. Grid By-Pass	Same as C-228			7616695 PT-31			
C-232	Capacitor-Intermed. Amp. Plate Tuning	Same as C-215			7616695 PT-32			
C-233	Capacitor-Intermed. Amp. Plate Trimmer	Same as C-216			7616695 PT-33			
*C-234	Capacitor-Intermed. Amp. By-Pass	1000 Mmfd., 500 V.	S#1353123	1	7616695 PT-34	15	2	2
C-235	Capacitor-R.F. Output Tuning	Single 3.2-25 Mmfd. 1/4 Dia. Rotor Shaft 1/8 In. Lg. Screw-driver Slot Single Hole Mounting	ARL-21-O	30	7616695 PT-35	1		
C-236	Capacitor-Tripler Grid Return By-Pass	Same as C-213			7616695 PT-36			
C-237	Capacitor-Oscillator Supply By-Pass	Same as C-213			7616695 PT-37			
C-238	Capacitor-Oscillator Cathode By-Pass	Same as C-213			7616695 PT-38			
C-240	Capacitor-Amp. Coupling	Same as C-211			7616695 PT-40			
C-242	Capacitor-Filter	.0043 Mfd., 500 V. Mica	JAN-C-5 CM35B432J		7616695 PT-42	1	1	1
C-243	Capacitor-By-Pass	Same as C-213			7616695 PT-43			
C-244	Capacitor-By-Pass	Same as C-213			7616695 PT-44			
C-245	Capacitor-Heater By-Pass	Same as C-213			7616695 PT-47			
C-246	Capacitor-Heater By-Pass	Same as C-213			7616695 PT-48			
C-247	Capacitor-Equalizing	330 Mmfd., 500 V. Mica	S#1353120	1	7616695 PT-49	1	1	1
*C-248	Capacitor-Disc. Primary Bandset	2.5 to 30 Mmfd., Variable	Norelco Air Trimmer	31	7616695 PT-50	2		
C-249	Capacitor-Disc. Primary Tuning	2.6 to 19.7 Mmfd., Variable	Part No. 16-110	27	7616695 PT-51	1		
C-250	Capacitor-Disc. Secondary Bandset	Same as C-248			7616695 PT-52			
C-251	Capacitor-Disc. Secondary Tuning	3.2 to 11.02 Mmfd., Variable	Part No. 160-211	27	7616695 PT-53	1		
<b>TYPE MP UNIT</b>								
*C-301	Capacitor-Buffer Cathode By-Pass	.0082 Mfd., 500 V. Mica	S#1353136	1	7616303 PT-1	26	3	3
C-302	Capacitor-Buffer Filament By-Pass	Same as C-301			7616303 PT-2			
C-303	Capacitor-Buffer Filament By-Pass	Same as C-301			7616303 PT-3			

PARTS AND RECOMMENDED SPARE PARTS LIST						PER UNIT	RECOM'D SPARE PARTS LIST	MINIMUM SPARE PARTS LIST
CIRCUIT SYMBOL	FUNCTION	DESCRIPTION	STYLE OR CAT. NO.	MFG.	WESTINGHOUSE DRAWING NO.			
C-304	Capacitor-Buffer Screen By-Pass	Same as C-301			7616303 PT-4			
*C-305	Capacitor-Buffer Plate Tank	5 to 50 Mmfd., Variable, (Mtg. Studs Tapped 4-40)	Type APC-50	4	7616303 PT-5	3		
C-306	Capacitor-Buffer Plate By-Pass	Same as C-301			7616303 PT-6			
C-307	Capacitor-Buffer Output Coupling	100 Mmfd., 500 V., Mica	S#1353116	1	7616303 PT-7	1	1	1
*C-308	Capacitor-#1 Mixer Phase Shift	15 Mmfd., 500 V., Mica	JAN-C-5 CM201B150K		7616303 PT-8	2	1	1
C-309	Capacitor-#1 Mixer Cathode By-Pass	Same as C-301			7616303 PT-9			
*C-310	Capacitor-#1 Mixer Plate By-Pass	51 Mmfd., 500 V., Mica	JAN-C-5 CM20B510J		7616303 PT-10	2	1	1
C-311	Capacitor-#1 Mixer Filament By-Pass	Same as C-301			7616303 PT-11			
C-312	Capacitor-#1 Mixer Filament By-Pass	Same as C-301			7616303 PT-12			
C-313	Capacitor-#1 Mixer Screen By-Pass	Same as C-202			7616303 PT-13			
*C-314	Capacitor-#1 Mixer Output Coupling	0.1 Mfd., 600 V. Tubular Paper	JAN-C-25 CP29A1EF104K		7616303 PT-14	2	1	1
C-315	Capacitor-Trigger Amplifier Coupling	0.25 Mfd., 600 V. Tubular Paper	JAN-C-25 CP29A1EF254K		7616303 PT-15	1	1	1
C-317	Capacitor-#2 Mixer Output Coupling	Same as C-314			7616303 PT-17			
*C-318	Capacitor-Multi-Output Differentiating	51 Mmfd., 500 V., Ceramic	JAN-C-20 CC36HR510J		7616303 PT-18	2	1	1
C-319	Capacitor-Multi-Output Differentiating	Same as C-318			7616303 PT-19			
C-323	Capacitor-Filament By-Pass	Same as C-301			7616303 PT-23			
C-324	Capacitor-Filament By-Pass	Same as C-301			7616303 PT-24			
C-336	Capacitor-Mixer Grid Return By-Pass	Same as C-301			7616303 PT-36			
C-337	Capacitor-Mixer Grid Meter By-Pass	Same as C-211			7616303 PT-37			
C-338	Capacitor-#2 Mixer Phase Shift	Same as C-308			7616303 PT-38			
C-339	Capacitor-Osc. Output Divider	Same as C-202			7616303 PT-39			
C-340	Capacitor-#2 Mixer Plate By-Pass	Same as C-310			7616303 PT-40			
C-341	Capacitor-#2 Mixer Cathode By-Pass	Same as C-301			7616303 PT-41			
C-342	Capacitor-#2 Mixer Filament By-Pass	Same as C-301			7616303 PT-42			
C-343	Capacitor-#2 Mixer Filament By-Pass	Same as C-301			7616303 PT-43			
C-344	Capacitor-#2 Mixer Screen By-Pass	Same as C-202			7616303 PT-44			
*C-345	Capacitor-Pulse Selector Output Coupling	200 Mmfd., 500 V., Ceramic	JAN-C-20 CC365K201J		7616303 PT-45	2	1	1
C-346	Capacitor-Pulse Selector Output Coupling	Same as C-345			7616303 PT-46			
C-347	Capacitor-Pulse Limiter Plate By-Pass	Same as C-301			7616303 PT-47			
*C-348	Capacitor-Pulse Amplifier Coupling	4 to 12 Mmfd., Variable	ATR-17-K	30	7616303 PT-48	2		
C-349	Capacitor-Pulse Amplifier Coupling	Same as C-348			7616303 PT-49			

PARTS AND RECOMMENDED SPARE PARTS LIST						PER UNIT	RECOM'D SPARE PARTS LIST	MINIMUM SPARE PARTS LIST
CIRCUIT SYMBOL	FUNCTION	DESCRIPTION	STYLE OR CAT. NO.	MFG.	WESTINGHOUSE DRAWING NO.			
*C-350	Capacitor-Charging Network By-Pass	.01 Mfd., 300 V., Mica	S# 1353157	1	7616303 PT-50	8	1	1
C-351	Capacitor-Charging Network By-Pass	Same as C-350			7616303 PT-51			
C-352	Capacitor-Pulse Storage	0.1 Mfd., 600 V., Metal Can, Paper	JAN-C-25 CP69B1EF104K		7616303 PT-52	1	1	1
*C-353	Capacitor-Bias Filter	.10 Mfd., 600 V., Metal Can, Paper	JAN-C-25 CP67B1EF105V		7616303 PT-53	2	1	1
C-354	Capacitor-Bias Filter	Same as C-353			7616303 PT-54			
C-355	Capacitor-Crystal Osc. Cathode By-Pass	Same as C-211			7616303 PT-55			
<b>TYPE MY UNIT</b>								
*C-401	Capacitor-Crystal Trimmer	3-25 Mmfd., Variable	APC-25	4	7616309 PT-1	4		
C-402	Capacitor-Oscillator Cathode By-Pass	Same as C-301			7616309 PT-2			
C-403	Capacitor-Oscillator Filament By-Pass	Same as C-301			7616309 PT-3			
C-404	Capacitor-Oscillator Filament By-Pass	Same as C-301			7616309 PT-4			
C-405	Capacitor-Oscillator Screen Tuning	Same as C-305			7616309 PT-5			
C-406	Capacitor-Oscillator Plate Tuning	Same as C-401			7616309 PT-6			
C-407	Capacitor-Oscillator Plate By-Pass	Same as C-301			7616309 PT-7			
C-408	Capacitor-Oscillator Output Coupling	12 Mmfd., 500 V., Mica	S# 1353111	1	7616309 PT-8	2	1	1
C-409	Capacitor-Oscillator Screen By-Pass	Same as C-301			7616309 PT-9			
C-410	Capacitor-Crystal Heater By-Pass	Same as C-350			7616309 PT-10			
C-411	Capacitor-Crystal Heater By-Pass	Same as C-350			7616309 PT-11			
C-412	Capacitor-Thermostat By-Pass	Same as C-350			7616309 PT-12			
<b>R.F. TRANSMISSION LINE VOLTMETER</b>								
C-503	Capacitor-R.F. Voltage Divider	3 to 12 Mmfd., Variable Ceramic	Style TS2A Type NPO	32	7717280 PT-7	1		
C-504	Capacitor-Filament By-Pass	100 ± 10 Mmfd., Ceramicon	N-750 Style T	32	7717280 PT-8	2	1	1
C-505	Capacitor-Filament By-Pass	Same as C-504			7717280 PT-9			
<b>LOW VOLTAGE REGULATOR</b>								
C-601	Capacitor-Regulator By-Pass	.25 Mfd., 600 V.	JAN-C-25 CP69B1EF254K		7617374 PT-1	1	1	1
C-602	Capacitor-Regulator By-Pass	Same as C-301			7617374 PT-2			
*C-603	Capacitor-Terminal By-Pass	.001 MFD., 500 V., Mica	S# 1353125	1	7617374 PT-36	4	1	1
C-604	Capacitor-Terminal By-Pass	Same as C-603			7617374 PT-37			
C-605	Capacitor-Terminal By-Pass	Same as C-603			7617374 PT-38			
C-606	Capacitor-Terminal By-Pass	Same as C-603			7617374 PT-39			



PARTS AND RECOMMENDED SPARE PARTS LIST						PER UNIT	RECOM'D SPARE PARTS LIST	MINIMUM SPARE PARTS LIST
CIRCUIT SYMBOL	FUNCTION	DESCRIPTION	STYLE OR CAT. NO.	MFG.	WESTINGHOUSE DRAWING NO.			
<b>AMPLIFIER-RECTIFIER</b>								
C-701	Capacitor-Driver Grid Tuning	30 Mmf., Variable	VU-30	4	7616532 PT-13	1		
C-702	Capacitor-Driver Input Loop Tuning	Same as C-305			7616532 PT-14			
C-703	Capacitor-Driver Plate Tuning	Butterfly		1	7717409 G-1	1		
C-704	Capacitor-P.A. Plate Tuning	Butterfly		1	7717396 G-1	1		
C-705	Capacitor-Driver Screen Grid Tuning	165 Mmf./Section Split Stator	XP-165-KD	6	7616532 PT-17	1		
*C-707	Capacitor-Left P.A. Grid Tuning	100 Mmf., Variable	NP-100-DS	6	7616532 PT-19	2		
C-708	Capacitor-Right P.A. Grid Tuning	Same as C-707			7616532 PT-20			
C-709A	Capacitor-Antenna Coupling Loop Tun.	Rotor		1	7718682 G-1	1		
C-709B	Capacitor-Antenna Coupling Loop Tun.	Stator		1	7718682 G-2	1		
*C-710	Capacitor-+2500 V., D-c. Filter	3000 V. D-c., 4 Mfd. Supply with Bracket S#1363423	S#1346568	1	7616532 PT-22	3	1	
C-711	Capacitor-+2500 V., D-c. Filter	Same as C-710			7616532 PT-32			
C-712	Capacitor-+2500 V., D-c. Filter	Same as C-710			7616532 PT-24			
*C-713	Capacitor-+400 V., D-c. Filter	1000 V. D-c., 6 Mfd. Supply with Bracket S#1363404	S#1346535	1	7616532 PT-25	7	1	
C-714	Capacitor-+400 V. D-c. Filter	Same as C-713			7616532 PT-26			
C-715	Capacitor-+400 V. D-c. Filter	Same as C-713			7616532 PT-27			
C-716	Capacitor-+400 V. D-c. Filter	Same as C-713			7616532 PT-28			
C-717	Capacitor-+400 V. D-c. Filter	Same as C-713			7616532 PT-29			
C-718	Capacitor-+400 V. D-c. Filter	Same as C-713			7616532 PT-30			
C-719	Capacitor-+400 V. D-c. Filter	Same as C-713			7616532 PT-31			
*C-722	Capacitor-Left Driver Screen By-Pass	1000 Mmf., 5000 V., D-c.	S#1353160	1	7616532 PT-34	2	1	1
C-723	Capacitor-Right Driver Screen By-Pass	Same as C-722			7616532 PT-35			
*C-724	Capacitor-Left Driver Filament By-Pass	1000 Mmf., 2500 V., D-c.	S#1353138	1	7616532 PT-36	51	5	5
C-725	Capacitor-Left Driver Filament By-Pass	Same as C-724			7616532 PT-37			
C-726	Capacitor-Right Driver Filament By-Pass	Same as C-724			7616532 PT-38			
C-727	Capacitor-Right Driver Filament By-Pass	Same as C-724			7616532 PT-39			
C-728	Capacitor-Driver Bias Contactor By-Pass	Same as C-724			7616532 PT-40			
C-729	Capacitor-Driver Grid Meter By-Pass	Same as C-724			7616532 PT-41			
C-730	Capacitor-Driver Plate Meter By-Pass	Same as C-724			7616532 PT-44			
C-731	Capacitor-Driver O.L. Relay By-Pass	Same as C-724			7616532 PT-46			
C-732	Capacitor-3 Kw. Amp. Bias Contactor By-Pass	Same as C-724			7616532 PT-47			

PARTS AND RECOMMENDED SPARE PARTS LIST						PER UNIT	RECOM'D SPARE PARTS LIST	MINIMUM SPARE PARTS LIST
CIRCUIT SYMBOL	FUNCTION	DESCRIPTION	STYLE OR CAT. NO.	MFG.	WESTINGHOUSE DRAWING NO.			
C-733	Capacitor-3 Kw. Amp. Grid Meter By-Pass	Same as C-724			7616532 PT-48			
C-734	Capacitor-Left 3 Kw. Amp. Plate O.L. By-Pass	Same as C-724			7616532 PT-51			
C-735	Capacitor-Right 3 Kw. Amp. Plate O.L. By-Pass	Same as C-724			7616532 PT-53			
C-736	Capacitor-3 Kw. Amp. Cathode Meter By-Pass	Same as C-724			7616532 PT-55			
C-737	Capacitor-3 Kw. Amp. Plate Choke By-Pass	100 Mmfd., 6000 V., D-c.	S# 1471534	1	7616532 PT-56	1	1	1
C-738	Capacitor-Driver Plate Choke By-Pass	100 Mmfd., 15000 V., D-c.	Type 851A	29	7616532 PT-57	1	1	1
C-743	Capacitor-R.F. Line V.M. By-Pass	Same as C-724			7616533 PT-62			
C-744	Capacitor-H.V. Rect. O.L. Relay By-Pass	Same as C-724			7616533 PT-63			
C-745	Capacitor-230 Bus Voltmeter By-Pass	Same as C-724			7616533 PT-64			
C-746	Capacitor-Filament Time Delay Relay By-Pass	Same as C-724			7616533 PT-65			
C-747	Capacitor-+400 V. Voltmeter By-Pass	Same as C-724			7616533 PT-66			
C-748	Capacitor-+400 V. O.L. Relay By-Pass	Same as C-724			7616533 PT-67			
C-749	Capacitor-Plate Voltmeter By-Pass	Same as C-724			7616533 PT-68			
C-750	Capacitor-Driver Grid Tuning Meter By-Pass	Same as C-724			7616533 PT-69			
C-751	Capacitor-Driver Plate Tuning Meter By-Pass	Same as C-724			7616533 PT-70			
C-753	Capacitor-3 Kw. Amp. Plate Tuning Meter By-Pass	Same as C-724			7616533 PT-72			
C-754	Capacitor-Transmission Line Coupling Meter By-Pass	Same as C-724			7616533 PT-73			
C-756	Capacitor-Left Driver Cathode By-Pass	Same as C-724			7616533 PT-75			
C-757	Capacitor-Left Driver Cathode By-Pass	Same as C-724			7616533 PT-76			
C-758	Capacitor-Right Driver Cathode By-Pass	Same as C-724			7616533 PT-77			
C-759	Capacitor-Right Driver Cathode By-Pass	Same as C-724			7616533 PT-78			
C-760	Capacitor-3 Kw. Amp. Left Fil. By-Pass	Same as C-724			7616533 PT-79			
C-761	Capacitor-3Kw. Amp. Left Fil. By-Pass	Same as C-724			7616533 PT-80			
C-762	Capacitor-3 Kw. Amp. Right Fil. By-Pass	Same as C-724			7616533 PT-81			
C-763	Capacitor-3 Kw. Amp. Right Fil. By-Pass	Same as C-724			7616533 PT-82			

PARTS AND RECOMMENDED SPARE PARTS LIST						PER UNIT	RECOM'D SPARE PARTS LIST	MINIMUM SPARE PARTS LIST
CIRCUIT SYMBOL	FUNCTION	DESCRIPTION	STYLE OR CAT. NO.	MFG.	WESTINGHOUSE DRAWING NO.			
C-766	Capacitor-3 Kw. Amp. Left Fil. By-Pass	Same as C-724			7616533 PT-85			
C-767	Capacitor-3 Kw. Amp. Left Fil. By-Pass	Same as C-724			7616533 PT-86			
C-768	Capacitor-3 Kw. Amp. Right Fil. By-Pass	Same as C-724			7616533 PT-87			
C-769	Capacitor-3 Kw. Amp. Right Fil. By-Pass	Same as C-724			7616533 PT-88			
C-770	Capacitor-3 Kw. Amp. Left Grid Leak By-Pass	Same as C-724			7616533 PT-89			
C-771	Capacitor-3 Kw. Amp. Right Grid Leak By-Pass	Same as C-724			7616533 PT-90			
C-772	Capacitor-Driver Grid Leak By-Pass	Same as C-724			7616533 PT-91			
C-773	Capacitor-24 V. Filter	Baltimore Works. To Finish 180E	RF-220-20	3	7616533 PT-92	1		
C-775	Capacitor-Modulated Oscillator Meter By-Pass	Same as C-724			7616764 PT-370			
C-776	Capacitor-Modulator Plate Meter By-Pass	Same as C-724			7616764 PT-371			
C-777	Capacitor-Intermed. Amp. Grid Meter By-Pass	Same as C-724			7616764 PT-372			
C-778	Capacitor-Tripler Grid Meter By-Pass	Same as C-724			7616764 PT-373			
C-779	Capacitor-Intermed. Amp. Plate Meter By-Pass	Same as C-724			7616764 PT-374			
C-780	Capacitor-Tripler Plate Meter By-Pass	Same as C-724			7616764 PT-375			
C-781	Capacitor-Driver Grid Control Motor	PT. of B-702			7616764 PT-376	1		
C-782	Capacitor-Driver Plate Control Motor	PT. of B-703			7616764 PT-377	1		
C-784	Capacitor-3 Kw. Amp. Plate Control Motor	PT. of B-705			7616764 PT-379	1		
C-785	Capacitor-Transmission Line Coupling Control Motor	Part of B-706			7616764 PT-380	1		
C-786	Capacitor-230 Volt Bus Regulator Motor	PT. of B-707			7616764 PT-381	1		
C-787	Capacitor-H.V. Bus Regulator Motor	PT. of B-708			7616764 PT-382	1		
C-788	Capacitor-3 Kw. Amp. Left Cathode By-Pass	Same as C-724			7616764 PT-383			
C-789	Capacitor-3 Kw. Amp. Left Cathode By-Pass	Same as C-724			7616764 PT-384			
C-790	Capacitor-3 Kw. Amp. Right Cathode By-Pass	Same as C-724			7616764 PT-385			
C-791	Capacitor-3 Kw. Amp. Right Cathode By-Pass	Same as C-724			7616764 PT-386			
C-792	Capacitor-By-Pass for K-720	Same as C-724			7616764 PT-388			

PARTS AND RECOMMENDED SPARE PARTS LIST						PER UNIT	RECOM'D SPARE PARTS LIST	MINIMUM SPARE PARTS LIST
CIRCUIT SYMBOL	FUNCTION	DESCRIPTION	STYLE OR CAT. NO.	MFG.	WESTINGHOUSE DRAWING NO.			
C-793	Capacitor-High Voltage O.L. By-Pass	Same as C-724			7616771 PT-463			
C-801	Capacitor-MO By-Pass	Same as C-234			7616771 PT-464			
C-802	Capacitor-MO By-Pass	Same as C-234			7616771 PT-465			
C-803	Capacitor-MO By-Pass	Same as C-234			7616771 PT-466			
C-804	Capacitor-MO By-Pass	Same as C-234			7616771 PT-467			
C-805	Capacitor-MO By-Pass	Same as C-234			7616771 PT-468			
C-806	Capacitor-MO By-Pass	Same as C-234			7616771 PT-469			
C-807	Capacitor-MO By-Pass	Same as C-234			7616771 PT-470			
C-808	Capacitor-MO By-Pass	Same as C-234			7616771 PT-471			
C-809	Capacitor-MO By-Pass	Same as C-234			7616771 PT-472			
C-810	Capacitor-MO By-Pass	Same as C-234			7616771 PT-473			
C-811	Capacitor-MO By-Pass	Same as C-234			7616771 PT-474			
C-812	Capacitor-MO By-Pass	Same as C-234			7616771 PT-475			
C-813	Capacitor-MO By-Pass	Same as C-234			7616771 PT-476			
C-814	Capacitor-MO By-Pass	Same as C-234			7616771 PT-477			
CR-701	Rectifier-Control Relay	Rectox-Fullwave Bridge 24.6 V., D-c., 0.42 Amp.	S# 861431A	1	7616771 PT-422	1		
CR-702	Rectifier-Indicator Meters	Rectox-Fullwave Bridge 6 V., D-c., 0.064 Amp.	S# 754826	1	7616771 PT-423	1		
*F-701	Fuse-230 V. Bus Voltmeter	1 Amp., 250 V.	S# 312001	7	7619743 PT-482	5	25	25
F-702	Fuse-230 V. Bus Voltmeter	Same as F-701			7619743 PT-483			
F-703	Fuse-230 V. Bus Voltmeter	Same as F-701			7619743 PT-484			
F-704	Fuse-230 V. Bus Voltmeter	Same as F-701			7619743 PT-485			
F-705	Fuse-230 V. Bus Voltmeter	Same as F-701			7619743 PT-486			
<b>TYPE MP UNIT</b>								
I-301	Indicator-Frequency Control "On"	Assembly, 125 Volt, Minalite	Receptacle S# 1124161 Bulb S# 1124156 Lens S# 1124157	1	7616304 PT-76	1		
I-302A	Indicator-Beat Indicator	Assembly, Neon Indicator	Receptacle # S1124158 Lens S# 1124152	1	7616304 PT-75	1		
I-302B	Neon Bulb for I-302A		Cat. # 5122	7	7616304 PT-74	1		
<b>AMPLIFIER-RECTIFIER</b>								
I-701	Indicator-Air "On"	Assembly, 250 Volts, Minalite	Receptacle S# 1124164 Lens S# 1124148 Lamp S# 1124156	1	7616533 PT-99	1		

PARTS AND RECOMMENDED SPARE PARTS LIST						PER UNIT	RECOM'D SPARE PARTS LIST	MINIMUM SPARE PARTS LIST
CIRCUIT SYMBOL	FUNCTION	DESCRIPTION	STYLE OR CAT. NO.	MFG.	WESTINGHOUSE DRAWING NO.			
*I-702	Indicator-Fil. "Ready"	Assembly, 250 Volt, Minalite Green	Receptacle S# 1124164 Lens S# 1124151 Lamp S# 1124156	1	7616533 PT-100	3		
I-703	Indicator-400 V. Rect. "Ready"	Assembly, Same as I-702			7616533 PT-101			
I-704	Indicator-H.V. Rect. "Ready"	Assembly, Same as I-702			7616533 PT-102			
I-705	Indicator-Filament "On"	Assembly, 250 Volts, Minalite Amber	Receptacle S# 1124164 Lens S# 1124154 Lamp S# 1124156	1	7616533 PT-103	1		
*I-706	Indicator-400 V. Rect. "On"	Assembly, 250 Volt, Minalite Red	Receptacle S# 1124164 Lens S# 1124150 Lamp S# 1124156	1	7616533 PT-104	2		
I-707	Indicator-H.V. Rect. "On"	Assembly, Same as I-706			7616533 PT-105			
I-708	Indicator-Crystal A-c.	12 V. Minalite Red	Receptacle S# 1124158 Lens S# 1124150 Telephone Lamp # 12-A	1	7616533 PT-106	1		
*I-709	Indicator-Crystal Heater # 1	Assembly, 12 V. Minalite Amber	Receptacle S# 1124158 Lens S# 1124154 Telephone Lamp # 12-A	1	7616533 PT-107	2		
*I-710	Indicator-Driver Plate O.L.	Assembly, 48 V. Minalite White	Receptacle S# 1124158 Lens S# 1124154 Telephone Lamp # 48C	1	7616533 PT-108	5		
I-711	Indicator-P.A. Plate O.L. Left	Assembly, Same as I-710			7616533 PT-109			
I-712	Indicator-P.A. Plate O.L. Right	Assembly, Same as I-710			7616533 PT-110			
I-713	Indicator-2500 V. Rectifier O.L.	Assembly, Same as I-710			7616533 PT-111			
I-714	Indicator-400 V. Rectifier O.L.	Assembly, Same as I-710			7616533 PT-112			
I-715	Indicator-Door Interlock	Assembly, 250 V., Minalite White	Receptacle S# 1124164 Lens S# 1124155 Lamp S# 1124156	1	7616533 PT-113	1		
I-716	Lamp Meter Illuminating	Daylight Fluorescent Tube T-5, 8W. Miniature Bipin		1	7616553 PT-114	3	2	2
I-717	Lamp Starter For 8 Watt Lamp		FS5	8	7616533 PT-115	3	1	1
I-718	Lamp Ballast For 8 Watt Lamp, 120 V., 60 Cy., See Note # 1.		58G 616	22	7616533 PT-116	3	1	
I-719	Indicator-Crystal Heater # 2	Same as I-709			7616533 PT-117			
I-720	Lamp Cubicle Illum. Bulb	110-120 V., 60 W. Med. Base 48 V. Minalite	Telephone Lamp # 480	1	7616533 PT-118	1	5	2
	Bulb	24 V., (For Use in 125 V. and 250 V. Minalites.)	S# 1124156	1		9	4	4
	Bulb	12 V. Minalite	Telephone Lamp # 12A	1		3	2	2
	Lens	Red Minalite	S# 1124150	1		3	1	
	Lens	Blue Minalite	S# 1124153	1		1	1	
	Lens	Green Minalite	S# 1124151	1		3	1	
	Lens	Amber Minalite	S# 1124154	1		3	1	
	Lens	White Minalite	S# 1124155	1		6	1	
	Lens	Clear Minalite	S# 1124152	1		1	1	

PARTS AND RECOMMENDED SPARE PARTS LIST						PER UNIT	RECOM'D SPARE PARTS LIST	MINIMUM SPARE PARTS LIST
CIRCUIT SYMBOL	FUNCTION	DESCRIPTION	STYLE OR CAT. NO.	MFG.	WESTINGHOUSE DRAWING NO.			
J-701	Receptacle-Utility	Duplex Type 15A, 125 V.	4832	8	7616764 PT-389	1		
*J-702	Receptacle-MP Unit Chassis	18 Female Contacts, 2 Coax. Type DP		1	7422644 G-1	1		
J-703	Receptacle-MO Unit Chassis	Same as J-702			7616764 PT-391	1		
J-704	Receptacle-Driver Grid	RG-8/U Cable Receptacle	83-1R	14	7616764 PT-392	1		
*K-701	Contactor-H.V. Rectifier Run	Type DN 140, 60 Cy., 3 Pole, 220 Volt. (With L-42 N.O. Int. Same as K-704A.)	S# 967917	1	7616534 PT-123	2		
K-702	Contactor-H.V. Rect. "Step-Start"	Same as K-701			7616534 PT-124			
K-703	Contactor-Filament	Type DN 040, 60 Cy., 3 Pole, 220 Volt	S# 1128819	1	7616534 PT-125	1		
K-704	Contactor-400 V. Rect.	Type DN 020, 60 Cy., 2 Pole, 220 Volt	S# 1128797	1	7616534 PT-126	1		
K-704A	Interlock for K-704	Type L-42, Normally Open	S# 972892	1	7616534 PT-129	3		
K-705	Relay-Rectifier Fil. Time Delay	60 Cycle, Type TD	S# 821100	1	7616534 PT-127	1		
K-706	Relay-Driver Bias			1	7716893 PT-1	1		
*K-707	Relay-Driver Plate O.L.	Type SC .25 to 1 Amp., D-c.	Similar to S# 1096937	1	7616534 PT-130	2		
K-708	Relay-3 Kw. Amp. Bias			1	7716893 PT-2	1		
*K-709	Relay-3 Kw. Amp. Left Plate O.L.	Type SC 1 to 4 Amp., D-c.	S# 1096938	1	7617534 PT-133	3		
K-710	Relay-3 Kw. Amp. Right Plate O.L.	Same as K-709			7616534 PT-134			
K-711	Relay-H.V. Rect. O.L.	Same as K-709			7616534 PT-135			
K-712	Relay-400 V. Rect. O.L.	Same as K-707			7616534 PT-136			
*K-713	Relay-Driver O.L. Supervisory	24 Volt, 300 Ohm Coil D.P. D.T. Octal Based, 2 Form "C" Contacts	Type K Sealed	25	7616534 PT-137	5		
K-714	Relay-Left 3 Kw. Amp. O.L. Supervisory	Same as K-713			7616534 PT-138			
K-715	Relay-Right 3 Kw. Amp. O.L. Supervisory	Same as K-713			7616534 PT-139			
K-716	Relay-2500 V. Rect. O.L. Supervisory	Same as K-713			7616534 PT-140			
K-717	Relay-400 V. Rect. O.L. Supervisory	Same as K-713			7616534 PT-141			
K-718	Relay-Spare Supvry.	Same as K-713 (See Note # 2).						
*K-720	Relay-Door Interlock	Type SG, 230 V., 50-60 Cy.	S# 1155694	1	7616534 PT-142	2		
K-721	Relay-2500 V. Rect. Master O.L.	Same as K-720			7616534 PT-144			
K-722	Relay-Spare Supervisory	Same as K-713 (See Note # 2).			7616534 PT-145			
	Operating Coil for S# 967917 Contactor (K-701, K-702)		S# 897933	1		2		
	Operating Coil for S# 1128819 and S# 1128797 Contactors (K-703, K-704)		S# 1115655	1		2		
	Moving Contacts for S# 967917 Contactor (K-701, K-702)		S# 899837	1		8	2	2
	Moving Contacts for S# 1128819 and S# 1128797 Contactors (K-703, K-704)		S# 1116634	1		6	2	2

PARTS AND RECOMMENDED SPARE PARTS LIST						PER UNIT	RECOM'D SPARE PARTS LIST	MINIMUM SPARE PARTS LIST
CIRCUIT SYMBOL	FUNCTION	DESCRIPTION	STYLE OR CAT. NO.	MFG.	WESTINGHOUSE DRAWING NO.			
	Washer Head Screw for Type DN Contactors		S# 665052	1		28	4	4
	Armature Core Guide for Type DN Contactors		S# 899842	1		4	1	1
	Operating Coil for SC Relay S# 1096937 (K-707, K-712)		S# 1003396	1		2		
	Operating Coil for SC Relay S# 1096938 (K-709, K-710 and K-711)		S# 1003397	1		3		
	Stationary Contacts for SC Relay S# 1096937 and S# 1096938		S# 1097234	1		10	2	2
	Moving Contacts for SC Relay S# 1096937 S# 1096938		S# 819792	1		5	1	1
	Operating Coil for SG Relay S# 1155694 (K-720, K-721)		S# 1008520	1		2		
	Right Moving Contact for SG Relay S# 1155694		S# 1008710	1		2	1	1
	Left Moving Contact for SG Relay S# 1155694		S# 1008709	1		2	1	1
	Stationary Make Contacts for SG Relay S# 1155694		S# 1102942	1		2	1	1
	Stationary Break Contacts for SG Relay S# 1155694		S# 1102943	1		2	1	1
	Stationary Contact for TD Relay S# 821100		S# 821388	1		2	2	2
<b>TYPE MO UNIT</b>								
L-202	Coil-Oscillator Grid Tank	13 T/In. 1" Dia. 1.5" Long 17 $\frac{3}{4}$ Turns #18 Wire		1	7422997 G-1	1		
L-203	Coil-Discriminator Pick-Up Link	1 Turn Close Wound on L-202		1	7616696 PT-75	1		
L-204	Choke-Oscillator Cathode	1.5 Mh., Multi-P1	# 4531	33	7616696 PT-82	1	1	1
L-205	Coil-Oscillator Plate	4 Turns Close Wound on L-206 (Pt. of G-1, Dwg. 7422991)				1		
L-206	Coil-829B Tripler Grid	9 Turns $\pm 2$ O.T. on Form Threaded 5 T/In. 1" O.D. #20 B & S		1	7422991 G-1	1		
L-207	Coil-829B Tripler Plate	4 Turns #12 B & S Self Supporting $\frac{1}{2}$ In. I.D.		1	7422984 PT-2	1		
L-208	Coil-Intermed. Amp. Plate	2 Turns Each Side Center Spaced, Self Supporting $\frac{5}{8}$ " I.D.		1	7422984 PT-3	1		
L-209	Coil-Output Coupling	2 Turns #12 B & S Self Supporting $\frac{5}{8}$ " I.D.		1	7422984 PT-1	1		
L-210	Choke-Intermed. Amp. Plate	$\frac{1}{2}$ Mh. Multi-P1	# 4531	33	7616696 PT-82	1	1	1
L-211	Coil-Discriminator	25 Turns, $\frac{5}{8}$ " O.D. Close Wound #22 B & S		1	7422912 G-2	1		
L-212	Coil-Discriminator	40 Turns $\frac{5}{8}$ " O.D. Close Wound, C.T., #22 B & S		1	7422912 G-1	1		
L-213	Coil-Discriminator Coupling	2 Turns Wound on L-211				1		

PARTS AND RECOMMENDED SPARE PARTS LIST						PER UNIT	RECOM'D SPARE PARTS LIST	MINIMUM SPARE PARTS LIST
CIRCUIT SYMBOL	FUNCTION	DESCRIPTION	STYLE OR CAT. NO.	MFG.	WESTINGHOUSE DRAWING NO.			
<b>TYPE MP UNIT</b>								
L-301	Coil-Buffer Plate Tank				1 7718390 G-1	1		
<b>TYPE MY UNIT</b>								
L-401	Coil-Oscillator Screen Tank				1 7717003 G-1	2		
L-402	Coil-Oscillator Plate Tank				1 7717004 G-1	2		
<b>AMPLIFIER RECTIFIER</b>								
*L-701	Choke-400 Volt Filter Input	2.5 H., 0.5 Amp.			1 L-Spec. 426694	2		
L-702	Choke-400 Volt Filter	Same as L-701			7616334 PT-150			
L-703	Choke-2500 Volt Filter	1 H., 2.7 Amp.			1 L-Spec. 428260	1		
L-704	Choke-Driver Grid	2 Micro-henries, 1 Amp.	Type Z-O	26	7616534 PT-152	1	1	1
*L-706	Choke-3 Kw. Amp. Left Grid			1	7427432 G-1	2	2	2
L-707	Choke-3 Kw. Amp. Right Grid	Same as L-706			7616534 PT-171			
*L-712	Choke-3 Kw. Amp. Plate			1	7717467 G-1	2	2	2
L-713	Choke-Driver Plate	Same as L-712			7616534 PT-161			
L-714	Loop-Driver Input			1	7717423 PT-1	1		
L-715	Coil-Driver Grid			1	7422945 PT-1	1		
L-716	Line-Driver Plate			1	7617584 G-1	1		
L-717	Loop-Driver Output					1		
L-718	Line-3 Kw. Cathode			1	7617564 G-1	1		
L-719	Line-3 Kw. Plate			1	7616611 G-1	1		
L-720	Line-3 Kw. Output			1	7426207 G-1	1		
L-721	Loop-Monitor Pick-Up			1	7426247 G-2	1		
<b>TYPE MO UNIT</b>								
M-201	Meter-Discriminator Differential Current	Type RX-33, 10-0-10 Zero Center Reading, D-c. Microammeter	S# 1203643	1	7616696 PT-95	1		
M-202	Meter-Discriminator Total Current	Type RX-33, 0-1 Ma., D-c.	S# 1203584	1	7616696 PT-96	1		
<b>TYPE MP UNIT</b>								
*M-301	Meter-Oscillator Cathode Current	0-25 Ma., D-c., Type RX-33	S# 1203596	1	7616304 PT-113	4		
M-302	Meter-Mixer Grid Current	Type RX-33, 0-2 Ma., D-c.	S# 1203586	1	7616304 PT-114	1		
<b>AMPLIFIER RECTIFIER</b>								
M-701	Meter-230 V., A-c. Bus Volts	0-300 V., A-c. Type RA-33	S# 1204030	1	7616534 PT-175	1		
*M-703	Meter-Driver Grid	Type KX-24 Similar to S# 1274651 Except with 0-50 Ma., D-c. Scale (See Note #3).	Similar to S# 1274651	1	7616534 PT-177	1		
M-704	Meter-Driver Plate	0-1 Amp., D-c. Type KX-24	S# 1274651	1	7616534 PT-178	2		
M-705	Meter-3 Kw. Amp. Grid	Same as M-704		1	7616535 PT-181			
M-706	Meter-3 Kw. Amp. Plate	0-3 Amp., D-c., Type KX-24	S# 1274653	1	7616535 PT-185	1	1	



PARTS AND RECOMMENDED SPARE PARTS LIST						PER UNIT	RECOM'D SPARE PARTS LIST	MINIMUM SPARE PARTS LIST
CIRCUIT SYMBOL	FUNCTION	DESCRIPTION	STYLE OR CAT. NO.	MFG.	WESTINGHOUSE DRAWING NO.			
M-707	Meter-2500 V. Rectifier Volts	0-3000 Volts, D-c., Type KX-24	S# 1341195	1	7616535 PT-186	1	1	
M-708	Meter-Time Totalizer	240 V., 60 Cy.	S# 1205874	1	7616535 PT-187	1		
M-709	Meter-Transmission Line R.F. Volts	Type KX-24, 0-1 Ma., D-c. Calibrate Scale 60 Divisions, 0-600V., Title R.F. Volts			7616535 PT-188	1		
*M-710	Meter-Driver Grid Tuning	Type RX-33, 0-1 Volts, D-c. Scale to be Marked "0-100"	Similar to S# 1203823	1	7616535 PT-189	4		
M-711	Meter-Driver Plate Tuning	Same as M-710			7616535 PT-190			
M-713	Meter-3 Kw. Amp. Plate Tuning	Same as M-710			7616535 PT-192			
M-714	Meter-Transmission Line Coupling	Same as M-710			7616535 PT-193			
M-715	Meter-Modulator Plate	Same as M-301			7616535 PT-194			
*M-716	Meter-Intermed. Amp. Plate	0-250 Ma., D-c., Type RX-33	S# 1203605	1	7616535 PT-195	2		
M-717	Meter-Intermed. Amp. Grid	Same as M-301			7616535 PT-196			
M-718	Meter-Tripler Plate	Same as M-716			7616535 PT-197			
M-719	Meter-Tripler Grid	Same as M-301			7616535 PT-198			
M-720	Meter-Modulated Oscillator	0-150 Ma., D-c., Type RX-33	S# 1203603	1	7616535 PT-199	1		
<b>TYPE MO UNIT</b>								
P-201	Connector-MO Unit Chassis	18 Male Contacts, Two Coax., Type DP		1	7422644 PT-3	1		
<b>TYPE MP UNIT</b>								
P-301	Connector-MP Unit Chassis	18 Male Contacts, Two Coax., Type DP		1	7422644 PT-2	1		
<b>TYPE MY UNIT</b>								
P-401	Plug Crystal Oscillator	Mica Filled Male 9 Pin Plug for .063 TK Panel	CP9T	14	7616309 PT-17	2		
<b>AMPLIFIER RECTIFIER</b>								
P-701	Plug-Driver Loop	RG-8/U Cable Plug, Single Plug	83-1SP	14	7616535 PT-202	1		
<b>TYPE MO UNIT</b>								
R-201	Resistor-Suppressor	12000 Ohms, 1 Watt	S# 1471040	1	7616696 PT-99	1	1	1
R-202	Resistor-Audio Voltage	5100 Ohms, 1 Watt	JAN-R-11 RC30BF5120		7616696 PT-100	1	1	1
*R-203	Resistor-Audio Amp. Grid	1.0 Megohm, 1 Watt	S# 1471212	1	7616696 PT-101	5	1	1
*R-204	Resistor-Series Audio	220,000 Ohms, 1 Watt	S# 1471204	1	7616696 PT-102	2	1	1
R-206	Resistor-Pre-Emphasis Time Constant	Same as R-204			7616696 PT-104			
*R-207	Resistor-Audio Amplifier Grid Feedback	18,000 Ohm, 1 Watt	S# 1471042	1	7616696 PT-105	2	1	1
R-208	Resistor-Modulator Diode Load	750 Ohm, 1 Watt	JAN-R-11 RC30BF751J		7616696 PT-106	1	1	1
R-209	Resistor-829B Tripler Grid Bias	15,000 Ohm, 2 Watt	S# 1471266	1	7616696 PT-107	1	1	1
*R-210	Resistor-Discriminator Diode Load	100,000 Ohm, 1 Watt	S# 1471200	1	7616696 PT-108	11	1	1

PARTS AND RECOMMENDED SPARE PARTS LIST						PER UNIT	RECOM'D SPARE PARTS LIST	MINIMUM SPARE PARTS LIST
CIRCUIT SYMBOL	FUNCTION	DESCRIPTION	STYLE OR CAT. NO.	MFG.	WESTINGHOUSE DRAWING NO.			
R-211	Resistor-Discriminator Diode Load	Same as R-210			7616696 PT-109			
R-212	Resistor-Oscillator Grid Bias	Same as R-207			7616696 PT-110			
R-214	Resistor-829B Tripler Cathode	160 Ohms, 31 Watt, Wire Wound	JAN-R-26 RW21G161		7616696 PT-112	1	1	1
*R-215	Resistor-829B Tripler Screen Dropping	5000 Ohms, 31 Watt, Wire Wound	JAN-R-26 RW21G502		7616696 PT-113	2	1	1
R-216	Resistor-829B Tripler Plate Decoupling	27 Ohms, 5 Watt, Wire Wound	Type AA B Coat	34	7616696 PT-114	1	1	1
R-217	Resistor-Intermediate Amplifier Grid	15000 Ohms, 10 Watt, Wire Wound	"Brown Devil"	26	7616696 PT-115	1	1	1
R-218	Resistor-Intermediate Amplifier Grid	Same as R-217			7616696 PT-116			
R-219	Resistor-Intermediate Amp. Cathode Bias	310 Ohm, 31 Watt, Wire Wound	JAN-R-26 RW21G311		7616696 PT-117	1	1	1
*R-220	Resistor-Intermediate Amp. Screen Dropping	3100 Ohm, 31 Watt, Wire Wound	JAN-R-26 RW21G312		7616696 PT-118	2	1	1
R-221	Resistor-Microammeter Series	Same as R-203			7616696 PT-119			
R-222	Resistor-Microammeter Series	Same as R-203			7616696 PT-120			
R-223	Resistor-Audio Amplifier Cathode	1200 Ohm, 1 Watt	S# 1471028	1	7616697 PT-121	1	1	1
R-225	Resistor-Audio Amp. Plate Load	270,000 Ohm, 1 Watt	S# 1471205	1	7616697 PT-123	1	1	1
*R-226	Resistor-Modulator Control Tube Grid	470,000 Ohm, 1 Watt	S# 1471208	1	7616697 PT-124	3	1	1
R-227	Resistor-Intermediate Amp. Screen Dropping	Same as R-220			7616697 PT-125			
R-228	Resistor-829B Tripler Screen	Same as R-215			7616697 PT-126			
*R-229	Resistor-Discriminator Return	33,000 Ohm, 1 Watt	S# 1471045	1	7616697 PT-127	2	1	1
R-230	Resistor-Oscillator Cathode	500 Ohm, 10 Watt, Wire Wound	"Brown Devil"	26	7616697 PT-128	1	1	1
<b>TYPE MP UNIT</b>								
R-301	Resistor-Buffer Grid	Same as R-210			7616305 PT-145			
R-302	Resistor-Buffer Cathode	100 Ohm, 1 Watt	S# 1471015	1	7616305 PT-146	1	1	1
*R-303	Resistor-Buffer Tank Damping	10,000 Ohm, 1 Watt	S# 1471039	1	7616305 PT-147	2	1	1
*R-304	Resistor-# 1 Phase Shift	1,000 Ohm, 1 Watt	S# 1471027	1	7616305 PT-148	2	1	1
*R-305	Resistor-# 1 Mixer Cathode	180 Ohm, 1 Watt	S# 1471018	1	7616305 PT-149	2	1	1
R-306	Resistor-Mixed Grid	47,000 Ohm, 1 Watt	S# 1471047	1	7616305 PT-150	1	1	1
*R-307	Resistor-# 1 Mixer Plate	47,000 Ohm, 2 Watt	S# 1471272	1	7616305 PT-151	3	1	1
R-308	Resistor-Trigger Amplifier Grid	Same as R-226			7616305 PT-152			
*R-309	Resistor-Trigger Amplifier Plate	100,000 Ohm, 2 Watt	S# 1471276	1	7616305 PT-153	2	1	1
R-310	Resistor-Trigger Amplifier Cathode	1500 Ohm, 1 Watt	S# 1471029	1	7616305 PT-154	1	1	1
*R-311	Resistor-Clipper Amplifier Grid	3.3 Megohm, 1 Watt	S# 1471218	1	7616305 PT-155	2	1	1
R-312	Resistor-Clipper Amplifier Grid	Same as R-226			7616305 PT-156			
R-313	Resistor-Trigger Shaping	Same as R-210			7616305 PT-157			

PARTS AND RECOMMENDED SPARE PARTS LIST						PER UNIT	RECOM'D SPARE PARTS LIST	MINIMUM SPARE PARTS LIST
CIRCUIT SYMBOL	FUNCTION	DESCRIPTION	STYLE OR CAT. NO.	MFG.	WESTINGHOUSE DRAWING NO.			
*R-314	Resistor-Clipper Amplifier Plate	22,000 Ohm, 2 Watt	S#1471268	1	7616305 PT-158	5	1	1
R-315	Resistor-Pulse Selector Plate	Same as R-210			7616305 PT-159			
R-316	Resistor-Pulse Selector Plate	Same as R-210			7616305 PT-160			
*R-317	Resistor-Multi-vibrator Grid	330,000 Ohm, 1 Watt	S#1471206	1	7616305 PT-161	3	1	1
*R-318	Resistor-Multi-vibrator Grid-Plate	560,000 Ohm, 1 Watt	S#1471209		7616305 PT-162	4	1	1
R-319	Resistor-Multi-vibrator Plate	Same as R-314			7616305 PT-163			
R-320	Resistor-Multi-vibrator Plate	Same as R-314			7616305 PT-164			
R-321	Resistor-Multi-vibrator Cathode	Same as R-314			7616305 PT-165			
R-322	Resistor-Multi-vibrator Grid-Plate	Same as R-318			7616305 PT-166			
R-323	Resistor-Multi-vibrator Grid	Same as R-317			7616305 PT-167			
R-324	Resistor-Multi-vibrator Cathode	Same as R-314			7616305 PT-168			
R-325	Resistor-Neon Indicator	Same as R-210			7616305 PT-169			
R-326	Resistor-Diode Return	Same as R-203			7616305 PT-170			
R-327	Resistor-Diode Return	Same as R-203			7616305 PT-171			
R-328	Resistor-Mixer Grid	Same as R-303			7616305 PT-172			
R-329	Resistor-# 2 Phase Shift	Same as R-304			7616305 PT-173			
R-330	Resistor-# 2 Mixer Cathode	Same as R-305			7616305 PT-174			
*R-331	Resistor-# 2 Mixer Screen	680 Ohm, 1 Watt	S#1471025	1	7616305 PT-175	2	1	1
R-332	Resistor-# 1 Mixer Screen	Same as R-331			7616305 PT-176			
R-333	Resistor-# 2 Mixer Plate	Same as R-307			7616305 PT-177			
R-334	Resistor-Pulse Selector Cathode	Same as R-210			7616305 PT-178			
R-335	Resistor-Pulse Selector Cathode	Same as R-210			7616305 PT-179			
R-336	Resistor-Pulse Amplifier Grid	Same as R-318			7616305 PT-180			
*R-337	Resistor-Pulse Amplifier Cathode	3300 Ohm, 2 Watt	S#1471258	1	7616305 PT-181	5	1	1
R-338	Resistor-Pulse Amplifier Grid	Same as R-318			7616305 PT-182			
R-339	Resistor-Pulse Limiter Bias	68,000 Ohm, 2 Watt	S#1471274	1	7616305 PT-183	1	1	1
*R-340	Resistor-Pulse Amplifier Plate	33,000 Ohm, 2 Watt	S#1471270	1	7616305 PT-184	2	1	
R-341	Resistor-Pulse Amplifier Plate	Same as R-340			7616305 PT-185			
R-342	Resistor-Pulse Limiter Bias	51,000 Ohm, 2 Watt	JAN-R-11 RC40BF513J		7616305 PT-186	1	1	2
R-343	Resistor-Off Control Centering	Same as R-337			7616305 PT-187			
R-344	Resistor-Off Control Centering	Same as R-337			7616305 PT-188			

PARTS AND RECOMMENDED SPARE PARTS LIST						PER UNIT	RECOM'D SPARE PARTS LIST	MINIMUM SPARE PARTS LIST
CIRCUIT SYMBOL	FUNCTION	DESCRIPTION	STYLE OR CAT. NO.	MFG.	WESTINGHOUSE DRAWING NO.			
R-345	Rheostat-Bias Adjusting	100,000 Ohm, 2 Watt Potentiometer Bradley Ohmmeter with Nut and Washer, Standard Tolerance, Linear Taper, Screw-driver Slotted Shaft Projecting 1/8 In., Resistance Value to be Stamped on Cover Bushing Length 3/8 In. Non-Locking Type.	Type J	35	7616305 PT-189	1	1	
R-346	Resistor-Pulse Counter Cathode	Same as R-307			7616305 PT-190			
R-349	Resistor-Cathode Follower Cathode	Same as R-309			7616305 PT-193			
*R-350	Resistor-Bias Filter	5600 Ohm, 2 Watt	S# 1471261	1	7616305 PT-194	4	1	1
R-351	Resistor-Bias Filter	Same as R-350			7616305 PT-195			
R-352	Resistor-+105 Volt Dropping	16,000 Ohm, 47 Watt, Wire Wound	JAN-R-26 RW23G163		7616305 PT-196	1	1	1
R-353	Resistor-+255 Volt Dropping	2,000 Ohm, 47 Watt, Wire Wound	JAN-R-26 RW23G202		7616305 PT-197	1	1	1
R-354	Resistor-+255 Volt Dropping	500 Ohm, 10 Watt, Wire Wound	"Brown Devil"	26	7616305 PT-198	1	1	1
<b>TYPE MY UNIT</b>								
R-401	Resistor-Oscillator Grid	Same as R-210			7616309 PT-20			
R-402	Resistor-Oscillator Cathode	390 Ohm, 2 Watt	S# 1471247	1	7616309 PT-21	2	1	1
R-403	Resistor-Oscillator Screen	Same as R-337			7616309 PT-22			
<b>R.F. TRANSMISSION LINE VOLTMETER</b>								
R-501	Resistor-R.F. Voltmeter Plate Series	39,000 Ohm, 1 Watt	S# 1471046	1	7717280 PT-10	1	1	1
<b>LOW VOLTAGE REGULATOR</b>								
R-601	Potentiometer-Regulator Bias	15,000 Ohm ±10%, 4 Watts Potentiometer		1	7422247 PT-4	1	1	
R-602	Resistor-Regulator Bleeder	Same as R-229			7617374 PT-6			
*R-603	Resistor-Regulator Plate Bal.	33 Ohm, 2 Watt	S# 1471234	1	7617374 PT-7	2	1	1
R-604	Resistor-Regulator Plate	Same as R-317			7617374 PT-8			
R-605	Resistor-Regulator Plate Bal.	Same as R-603			7617374 PT-9			
*R-606	Resistor-Regulator Grid Sup.	1,000 Ohm, 1/2 Watt	S# 1471001	1	7617374 PT-10	3	1	1
R-607	Resistor-Regulator Grid Sup.	Same as R-606			7617374 PT-11			
R-608	Resistor-Regulator Screen Bleeder	3900 Ohm, 2 Watt	S# 1471259	1	7617374 PT-12	1	1	1
R-609	Resistor-Regulator Screen Bleeder	Same as R-350			7617374 PT-13			
R-610	Resistor-Regulator Screen Bleeder	Same as R-350			7617374 PT-14			
R-611	Resistor-Regulator Bleeder	68,000 Ohm, 1 Watt	S# 1471198	1	7617374 PT-15	1	1	1
R-612	Resistor-Regulator Grid Sup.	Same as R-606			7617374 PT-16			
R-613	Resistor-Regulator Feedback	Same as R-311			7617374 PT-17			

PARTS AND RECOMMENDED SPARE PARTS LIST						PER UNIT	RECOM'D SPARE PARTS LIST	MINIMUM SPARE PARTS LIST
CIRCUIT SYMBOL	FUNCTION	DESCRIPTION	STYLE OR CAT. NO.	MFG.	WESTINGHOUSE DRAWING NO.			
<b>AMPLIFIER RECTIFIER</b>								
*R-701	Resistor-Step-Start	12 Ohms, 140 Watt Wire Wound	JAN-R-26 RW10G120		7616535 PT-206	3	2	1
R-702	Resistor-Step-Start	Same as R-701			7616535 PT-207			
R-703	Resistor-Step-Start	Same as R-701			7616535 PT-208			
R-709	Resistor-Driver Grid	4000 Ohms, 20 Watt Wire Wound	JAN-R-26 RW15G402		7616535 PT-214	1	1	1
*R-712	Resistor-Left Driver Screen	12,000 Ohms, 140 Watt Wire Wound	JAN-R-26 RW10G123		7616535 PT-218	2	1	1
*R-713	Resistor-Left Driver Screen	16,000 Ohms, 140 Watt Wire Wound	JAN-R-26 RW10G163		7616535 PT-219	2	1	1
R-714	Resistor-Right Driver Screen	Same as R-712			7616535 PT-220			
R-715	Resistor-Right Driver Screen	Same as R-713			7616535 PT-221			
*R-716	Resistor-Left 3 Kw. Amp. Grid Leak	1600 Ohms, 90 Watt Wire Wound	JAN-R-26 RW12G162		7616535 PT-222	4	2	2
R-717	Resistor-Right 3 Kw. Amp. Grid Leak	Same as R-716			7616535 PT-223			
*R-718	Resistor-Suppressor Left Driver Screen	120 Ohms, 20 Watt Wire Wound	JAN-R-26 RW15G121		7616535 PT-224	2	2	2
R-719	Resistor-Suppressor Right Driver Screen	Same as R-718			7616535 PT-225			
R-720	Resistor-3 Kw. Amp. Cathode	80 Ohms, 50 Watt, Wire Wound	JAN-R-26 RW13G800		7616535 PT-226	1	1	1
*R-721	Potentiometer-Driver Grid Tuning Ind.	300 Ohm $\pm 10\%$ , 2 Watt		1	7422247 PT-1	4	1	
R-722	Potentiometer-Driver Plate Tuning Ind.	Same as R-721			7616535 PT-229			
R-724	Potentiometer-3 Kw. Amp. Plate Tank Ind.	Same as R-721			7616535 PT-231			
R-725	Potentiometer-Output Coupling Ind.	Same as R-721			7616535 PT-232			
*R-726	Rheostat-Driver Grid Zero Set	1500 Ohm, 2 Watt		1	7422247 PT-3	4	1	
R-727	Rheostat-Driver Plate Zero Set	Same as R-726			7616535 PT-234			
R-729	Rheostat-3 Kw. Amp. Tank Zero Set	Same as R-726			7616535 PT-236			
R-730	Rheostat-3 Kw. Amp. Output Coupling Zero Set	Same as R-726			7616535 PT-237			
R-746	Resistor-2500 V. Rect. VM Multiplier 1 Megohm Section for S# 1158217	3 Megohm with Ferrules	S# 1158217	1	7616536 PT-251	1		
R-747	Resistor-3 Kw. Amp. Left Grid Leak	Same as R-716	S# 1099345	1		3	1	1
R-748	Resistor-3 Kw. Amp. Right Grid Leak	Same as R-716			7616536 PT-253			
*R-750	Resistor-For Ind. Lamp I-702	7100 Ohms, Part of I-702, (Part of S# 1124164 Receptacle)	S# 1124248	1	7616536 PT-254			
R-751	Resistor-For Ind. Lamp I-703	Same as R-750			7616764 PT-393	8	1	
R-752	Resistor-For Ind. Lamp I-704	Same as R-750			7616764 PT-394			
R-753	Resistor-For Ind. Lamp I-705	Same as R-750			7616764 PT-395			
R-754	Resistor-For Ind. Lamp I-706	Same as R-750			7616764 PT-396			
R-755	Resistor-For Ind. Lamp I-707	Same as R-750			7616764 PT-397			
R-761	Resistor-For Ind. Lamp I-715	Same as R-750			7616764 PT-398			
					7616764 PT-405			

PARTS AND RECOMMENDED SPARE PARTS LIST						PER UNIT	RECOM'D SPARE PARTS LIST	MINIMUM SPARE PARTS LIST
CIRCUIT SYMBOL	FUNCTION	DESCRIPTION	STYLE OR CAT. NO.	MFG.	WESTINGHOUSE DRAWING NO.			
R-762	Resistor-Fil. Bus Control Motor	Part of B-707			7616764 PT-406			
R-763	Resistor-H.V. Bus Control Motor	Part of B-708			7616764 PT-407			
R-764	Resistor-For Ind. Lamp I-701	Same as R-750			7616764 PT-408			
*R-765	Resistor-Shunt for K-708	15 Ohm, 10 Watt, Wire Wound	"Brown Devil"	26	7616764 PT-409	2	1	
R-766	Resistor-400 V., O.L. Relay Shunt	Same as R-765			7616764 PT-410			
R-767	Resistor-Tuning Indicator Voltage Drop	100 Ohm, 3 Watt, Potentiometer	JAN-R-19		7616764 PT-411	1	1	
*R-768	Resistor-2500 V. Meter Protective Shunt	680,000 Ohm, 2 Watt	RA25A1S101AK S#1471286	1	7616536 PT-255	2	1	1
R-769	Resistor-2500 V. Meter Protective Shunt	Same as R-768			7616536 PT-256			
<b>TYPE MO UNIT</b>								
S-201	Switch-Pre-Emphasis Cutout	D.P.D.T. (2 Pole, 2 Position, 60° Throw, Oak Type DHC for Tropical Use)		1	7716956 PT-1	2		
<b>TYPE MP UNIT</b>								
S-301	Switch-Crystal Osc. Selector	Same as S-201		1	7716956 PT-1			
S-302	Switch-Control Off/On	3 Pole Double Throw		1	7716956 PT-2	1		
<b>AMPLIFIER RECTIFIER</b>								
S-701	Switch-H.V. Rect. Line	Type AB, Frame "E" De-ion Breaker, 3 Pole, 35 Amp.	S# 999025	1	7616536 PT-257	1		
S-702	Switch-230 V. Bus Line	Type AB, Frame "E" De-ion Breaker, 3 Pole, 15 Amp.	S# 999022	1	7616536 PT-258	1		
*S-703	Switch-Filament "On-Off"	Rotary S.P.D.T. with Panel Bracket	S#1224527	1	7616536 PT-259	3	1	
S-704	Switch-400 Volt Rect.	Same as S-703			7616536 PT-260			
S-705	Switch-H.V. Rect.	Same as S-703			7616536 PT-261			
*S-706	Switch-230 V. Bus "Raise-Lower"	One Form "A" and One Form "B" Contacts Each Side "B" to Open Before "A'S" Close	Lever Key A-27436	25	7616536 PT-262	6	1	
S-707	Switch-H.V. Rect. "Raise-Lower"	Same as S-706			7616536 PT-263			
S-708	Switch-Driver Grid Tuning	Same as S-706			7616536 PT-264			
S-709	Switch-Driver Plate Tuning	Same as S-706			7616536 PT-265			
S-711	Switch-3 Kw. Amp. Plate Tuning	Same as S-706			7616536 PT-267			
S-712	Switch-Antenna Coupling	Same as S-706			7616536 PT-268			
*S-713	Switch-Driver Grid Tuning Max. Limit	One Normally Open Contact	YZ-RL2T	11	7616536 PT-269	8	2	
S-714	Switch-Driver Grid Tuning Min. Limit	Same as S-713			7616536 PT-270			
S-715	Switch-Driver Plate Tuning Max. Limit	Same as S-713			7616536 PT-271			
S-716	Switch-Driver Plate Tuning Min. Limit	Same as S-713			7616536 PT-272			

PARTS AND RECOMMENDED SPARE PARTS LIST						PER UNIT	RECOM'D SPARE PARTS LIST	MINIMUM SPARE PARTS LIST
CIRCUIT SYMBOL	FUNCTION	DESCRIPTION	STYLE OR CAT. NO.	MFG.	WESTINGHOUSE DRAWING NO.			
S-719	Switch-3 Kw. Amp. Plate Tuning Max. Limit	Same as S-713			7616536 PT-275			
S-720	Switch-3 Kw. Amp. Plate Tuning Min. Limit	Same as S-713			7616536 PT-276			
S-721	Switch-Output Coupling Max. Limit	Same as S-713			7616536 PT-277			
S-722	Switch-Output Coupling Min. Limit	Same as S-713			7616536 PT-278			
S-723	Switch-Interior Cubicle Light	S.P.S.T. Normally Closed	WZ-RQ1	11	7616536 PT-279	1		
*S-724	Switch-Left Hand Rear Door Interlock	S.P.S.T. Normally Open	YZ-RQ1	11	7616536 PT-280	5	1	
S-725	Switch-Upper Front Window Interlock	Same as S-724			7616536 PT-281			
S-726	Switch-Lower Tube Window Interlock	Same as S-724			7616536 PT-282			
*S-727A	Switch-Air Interlock		Type Z WZ-RL	11	7616536 PT-283	2	1	
S-727B	Switch-Air Interlock	Same as S-727A			7616764 PT-420			
S-731	Switch-115 V., A-c. Line	Type AB, De-ion Breaker, 2 Pole, 15 Amp. Pt. of T-718	S# 999082	1	7616536 PT-287	1		
S-732	Switch-230 V. Bus Regulator Max. Limit	Pt. of T-718			7616536 PT-288			
S-733	Switch-230 V. Bus Regulator Min. Limit	Pt. of T-718			7616536 PT-289			
S-734	Switch-H.V. Rectifier Regulator Max. Limit	Pt. of T-219			7616536 PT-290			
S-735	Switch-H.V. Rectifier Regulator Min. Limit	Pt. of T-719			7616536 PT-261			
S-736	Switch-Supervisory Indicator Reset	2 Point Push Button with Mounting Bracket-Black	S# 1033638	1	7616764 PT-412	1		
*S-737	Switch-Right Hand Rear Door Grounding			1	7717294 G-1	4		
S-738	Phase Switch, 230 V., A-c. Voltmeter	6 Position, 60° Throw		1	7717623 PT-1	1		
S-739	Switch-Control Panel Interlock	Same as S-724			7616764 PT-415			
S-740	Switch-Right Hand Rear Door Interlock	Same as S-724			7616764 PT-416			
S-741	Switch-Left Hand Rear Door H.V. Grounding	Same as S-737			7616764 PT-417			
S-742	Switch-Front Window H.V. Grounding	Same as S-737			7616764 PT-418			
S-743	Switch-Lower Tube Window H.V. Grounding	Same as S-737			7616764 PT-419			
<b>TYPE MO UNIT</b>								
T-201	Transformer-Audio Input	600 Ohm Line to Grid		1	L-Spec.-428246	1		
<b>TYPE MP UNIT</b>								
T-301	Transformer Bias Supply	385 Ct., 2.42 V.A.		1	L-Spec.-428247	1		

PARTS AND RECOMMENDED SPARE PARTS LIST						PER UNIT	RECOM'D SPARE PARTS LIST	MINIMUM SPARE PARTS LIST
CIRCUIT SYMBOL	FUNCTION	DESCRIPTION	STYLE OR CAT. NO.	MFG.	WESTINGHOUSE DRAWING NO.			
<b>LOW VOLTAGE REGULATOR</b>								
T-601	Transformer-Regulator Filament	6.3 V. at 2.5 Amp.; 6.3 V. at .3 Amp.		1	L-Spec.-428244	1		
*T-701	Transformer-2500 V. Rectifier	1870 Volts, 15.7 Amp.		1	L-Spec.-428259	3		
T-702	Transformer-2500 V. Rectifier	Same as T-701			7616536 PT-294			
T-703	Transformer-2500 V. Rectifier	Same as T-701			7616536 PT-295			
T-704	Transformer-400 V. Rect. Plate	1010 Ct., 238 V.A.		1	L-Spec.-428243	1		
T-705	Transformer-400 V. Rect. Filament	2.5 V. at 10 Amp.		1	L-Spec. 428237	1		
*T-706	Transformer-2500 V. Rectifier Filament	5 V. Ct.-7.5 Amp.		1	L-Spec.-453623	6	1	
T-707	Transformer-2500 V. Rectifier Filament	Same as T-706			7616536 PT-299			
T-708	Transformer-2500 V. Rectifier Filament	Same as T-706			7616536 PT-300			
T-709	Transformer-2500 V. Rectifier Filament	Same as T-706			7616537 PT-301			
T-710	Transformer-2500 V. Rectifier Filament	Same as T-706			7616537 PT-302			
T-711	Transformer-2500 V. Rectifier Filament	Same as T-706			7616537 PT-303			
*T-712	Transformer-Left Driver Filament	230 V. Pri. Tapped for Scott Connection 2 Phase-Sec. 5 V.-Ct., 14.5 Amp.		1	L-Spec.-428335	2		
T-713	Transformer-Right Driver Filament	Same as T-712			7616537 PT-305			
*T-714	Transformer-Left 3 Kw. Amp. Filament	230 V. Pri. Tapped for Scott Connection 2 Phase-Sec. 6 V.-Ct., 60 Amp.		1	L-Spec.-428257	2		
T-715	Transformer-Right 3 Kw. Amp. Filament	Same as T-714			7616537 PT-307			
T-717	Transformer-MO and MP Unit Filaments	6.6 V. 15 Amp. and 6.3 V., 2 Amp.		1	L-Spec.-428241	1		
T-718	Transformer-230 V. Bus Regulator	208/230/240 V. 3 Phase Line 3.58 Max. Kva. Westinghouse to Tap Base Holes 1/16-14 for Mtg. on Plate 7423095.	Type S-742 Spec. BP2197	20	7616537 PT-310	1		
T-719	Transformer-2500 V. Rectifier Regulator	208/230/240 V. 3 Phase Line 7.6 Max. Kva.	Type S-741 Spec.-BP2355	20	7616537 PT-311	1		
T-720	Transformer-Tuning Motor Supply	Pri. 230 V., Sec. 115 V., 2 Amp. 35 V., 1 Amp.		1	L-Spec.-428286	1		
T-721	Transformer-Crystal Heater Power	Pri. 115 V., Sec. 6.3 V., 3 Amp.		1	L-Spec.-428283	1		
<b>R.F. TRANSMISSION LINE VOLTMETER</b>								
TB-501	Terminal Block R.F. Voltmeter Rectifier	4 Terminals	141Y-4	28	7717280 PT-6	1		
<b>LOW VOLTAGE REGULATOR</b>								
TB-601	Terminal Block Low Voltage Regulator	5 Terminals, S# 805454 Alter Marker Strip Per PT-1, Dwg. 7611810		1	7422315 PT-17	1		



PARTS AND RECOMMENDED SPARE PARTS LIST						PER UNIT	RECOM'D SPARE PARTS LIST	MINIMUM SPARE PARTS LIST
CIRCUIT SYMBOL	FUNCTION	DESCRIPTION	STYLE OR CAT. NO.	MFG.	WESTINGHOUSE DRAWING NO.			
<b>AMPLIFIER RECTIFIER</b>								
TB-701A	Terminal Block-Power and Remote	8 Terminals	S# 805431	1	7616771 PT-430	1		
*TB-701B	Terminal Block-Power and Remote	5 Terminals	S# 805430	1	7616771 PT-431	2		
*TB-701C	Terminal Block-Power and Remote	12 Terminals	S# 805432	1	7616771 PT-432	3		
*TB-703A	Terminal Block-Supervisory Relays	17 Terminals	141-17	28	7616771 PT-436	2		
TB-703B	Terminal Block-Relay	Same as TB-703A			7616771 PT-435			
*TB-705A	Terminal Block-Control Panel	17 Terminals	142-17	28	7616771 PT-437	6		
TB-705B	Terminal Block-Control Panel	Same as TB-705A			7616771 PT-438			
TB-705C	Terminal Block-Control Panel	Same as TB-705A			7616771 PT-439			
TB-705D	Terminal Block-Control Panel	Same as TB-705A			7616771 PT-440			
TB-705E	Terminal Block-Control Panel	10 Terminals	142-10	28	7616771 PT-441	1		
TB-706	Terminal Block-MP Unit	Same as TB-705A			7616771 PT-442			
TB-707	Terminal Block-MO Unit	Same as TB-705A			7616771 PT-443			
*TB-708	Terminal Block-Tuning Motor	5 Terminals	142-5	28	7616771 PT-444	4		
TB-709	Terminal Block-Tuning Motor	Same as TB-708			7616771 PT-445			
TB-711	Terminal Block-Tuning Motor	Same as TB-708			7616771 PT-447			
TB-712	Terminal Block-Tuning Motor	Same as TB-708			7616771 PT-448			
TB-713A	Terminal Block-Remote	Same as TB-701C			7616771 PT-449			
TB-713B	Terminal Block-Remote	Same as TB-701B			7616771 PT-450			
TB-714	Terminal Block-Rectox	4 Terminals	142-4	28	7616771 PT-451	1		
*TB-715A	Terminal Block-Metering	15 Terminals	142-15	28	7616761 PT-452	2		
TB-715B	Terminal Block-Metering	Same as TB-715A			7616771 PT-453			
TB-716	Terminal Block-Audio and Auxiliary	Same as TB-701C			7616771 PT-454			
<b>TYPE MO UNIT</b>								
*V-201	Tube-Audio Amplifier	Pentode	6SJ7	1	7503463 PT-5	3		
*V-202	Tube-Control Amplifier	Beam Power Tetrode	1614	1	7503463 PT-19	4		
*V-203	Tube-Modulator	Twin Diode	6H6	1	7503463 PT-3	6		
V-204	Tube-Discriminator	Same as V-203						
V-205	Tube-Oscillator-Tripler	Same as V-202						
*V-206	Tube-Tripler	Push-Pull Beam Tetrode	829B	1	7503463 PT-18	2		
V-207	Tube-Intermediate Amplifier	Same as V-206						
V-301	Tube-Buffer Amplifier	Same as V-201						
*V-302	Tube-#1 Mixer	Pentagrid Converter	6SA7	1	7503463 PT-4	2		
*V-303	Tube-Mixer Amplifier	Twin Triode	6SN7-GT	1	7503463 PT-7	2		
V-304	Tube-Multivibrator	Same as V-303						

PARTS AND RECOMMENDED SPARE PARTS LIST						PER UNIT	RECOM'D SPARE PARTS LIST	MINIMUM SPARE PARTS LIST
CIRCUIT SYMBOL	FUNCTION	DESCRIPTION	STYLE OR CAT. NO.	MFG.	WESTINGHOUSE DRAWING NO.			
V-307	Tube-# 2 Mixer	Same as V-302						
V-308	Tube-Pulse Discriminator	Same as V-203						
*V-309	Tube-Pulse Amplifier	Twin Triode	6SL7-GT	1	7503463 PT-6	2		
V-310	Tube-Pulse Limiter	Same as V-203						
V-311	Tube-Pulse Integrator	Same as V-203						
V-312	Tube-Pulse Integrator	Same as V-203						
V-313	Tube-Cathode Follower	Same as V-309						
V-314	Tube-Bias Rectifier	Full Wave Rectifier	6X5GT/G	1	7503463 PT-10	1		
*V-315	Tube-Bias Regulator	105 V. Regulator	OC3/VR105	1	7503463 PT-1	3		
V-316	Tube-+255 V. Regulator	150 V. Regulator	003/VR150	1	7503463 PT-2	1		
V-317	Tube-+105 V. Regulator	Same as V-315						
<b>TYPE MY UNIT</b>								
V-401	Tube-Crystal Oscillator	Same as V-202						
<b>R.F. TRANSMISSION LINE VOLTMETER</b>								
V-501	Tube-R.F. Voltmeter Rectifier	Diode	9006	1	7503463 PT-20	1		
<b>LOW VOLTAGE REGULATOR</b>								
*V-601	Tube-Low Voltage Regulator	Beam Power Tetrode	6Y6G	1	7503463 PT-11	2		
V-602	Tube-Low Voltage Regulator	Same as V-601						
V-603	Tube-Low Voltage Regulator Amplifier	Same as V-201						
V-604	Tube-Low Voltage Regulator Bias	Same as V-315						
<b>AMPLIFIER RECTIFIER</b>								
*V-701	Tube-400 V. Rectifier	Mercury Vapor Rectifier	WL866A	1	7503463 PT-21	2		
V-702	Tube-400 V. Rectifier	Same as V-701						
*V-703	Tube-2500 V. Rectifier	Mercury Vapor Rectifier	WL872A	1	7503463 PT-22	6		
V-704	Tube-2500 V. Rectifier	Same as V-703						
V-705	Tube-2500 V. Rectifier	Same as V-703						
V-706	Tube-2500 V. Rectifier	Same as V-703						
V-707	Tube-2500 V. Rectifier	Same as V-703						
V-708	Tube-2500 V. Rectifier	Same as V-703						
*V-709	Tube-Left Hand Driver	Power Tetrode	WL5D22/4-250A	1	7503463 PT-24	2		
V-710	Tube-Right Hand Driver	Same as V-709						
*V-711	Tube-Left Hand 3 Kw. Amplifier	Power Triode	WL473	1	7503463 PT-14	2		
V-712	Tube-Right Hand 3 Kw. Amplifier	Same as V-712						

PARTS AND RECOMMENDED SPARE PARTS LIST							PER UNIT	RECOM'D SPARE PARTS LIST	MINIMUM SPARE PARTS LIST
CIRCUIT SYMBOL	FUNCTION	DESCRIPTION	STYLE OR CAT. NO.	MFG.	WESTINGHOUSE DRAWING NO.	QUANTITY			
<b>TYPE MO UNIT</b>									
*X-201	Socket-Audio Amplifier Tube	Octal		1	7706979 PT-3	31	3	1	
X-202	Socket-Control Amplifier Tube	Same as X-201			7616697 PT-179				
*X-203	Socket-Moulator Tube	Octal	RSS8	14	7616697 PT-180	2	1	1	
X-204	Socket-Discriminator Tube	Same as X-201			7616698 PT-181				
X-205	Socket-Oscillator Tripler Tube	Same as X-203			7616698 PT-182				
X-206	Socket-Tripler Tube	Socket for 829-B (Order with Shield No. 115152)	#115146	36	7616698 PT-183	1			
X-207	Socket-Intermediate Amplifier Tube	Socket for 829-B	#E115153	36	7616698 PT-184	1			
<b>TYPE MP UNIT</b>									
X-301	Socket Buffer Amplifier Tube	Same as X-201			7616306 PT-246				
X-302	Socket-#1 Mixer Tube	Same as X-201			7616306 PT-247				
X-303	Socket-Amplifier Tube	Same as X-201			7616306 PT-248				
X-304	Socket-Multi-vibrator Tube	Same as X-201			7616306 PT-249				
X-307	Socket-#2 Mixer Tube	Same as X-201			7616306 PT-252				
X-308	Socket-Pulse Selector Tube	Same as X-201			7616306 PT-253				
X-309	Socket-Pulse Amplifier Tube	Same as X-201			7616306 PT-254				
X-310	Socket-Pulse Limiter Tube	Same as X-201			7616306 PT-255				
X-311	Socket-Pulse Integrator Diode Tube	Same as X-201			7616306 PT-256				
X-312	Socket-Pulse Integrator Diode Tube	Same as X-201			7616306 PT-257				
X-313	Socket-Cathode Follower Tube	Same as X-201			7616306 PT-258				
X-314	Socket-Bias Rectifier Tube	Same as X-201			7616308 PT-259				
X-315	Socket-Bias Regulator Tube	Same as X-201			7616306 PT-260				
X-316	Socket-+255 V. Regulator Tube	Same as X-201			7616306 PT-261				
X-317	Socket-+105 V. Regulator Tube	Same as X-201			7616306 PT-262				
*X-318	Socket-#1 Crystal Oscillator	9 Pin	S9T	14	7616306 PT-263	2			
X-319	Socket-#2 Crystal Oscillator	Same as X-318			7616306 PT-264				
<b>TYPE MY UNIT</b>									
X-401	Socket-Oscillator Tube	Same as X-201			7616309 PT-35				
X-402	Socket-Crystal	Giant 7 Pin	#237	14	7616309 PT-36	2			

PARTS AND RECOMMENDED SPARE PARTS LIST						PER UNIT	RECOM'D SPARE PARTS LIST	MINIMUM SPARE PARTS LIST
CIRCUIT SYMBOL	FUNCTION	DESCRIPTION	STYLE OR CAT. NO.	MFG.	WESTINGHOUSE DRAWING NO.			
		<b>R.F. TRANSMISSION LINE VOLTMETER</b>						
X-501	Socket-R.F. Voltmeter Rectifier Tube	7 Pin Miniature	No. 7676	15	7717280 PT-11	1		
		<b>LOW VOLTAGE REGULATOR</b>						
X-601	Socket-Regulator Tube	Same as X-201			7617374 PT-26			
X-602	Socket-Regulator Tube	Same as X-201			7617374 PT-27			
X-603	Socket-Regulator Amplifier Tube	Same as X-201			7617374 PT-28			
X-604	Socket-Regulator Bias Tube	Same as X-201			7617374 PT-29			
		<b>AMPLIFIER-RECTIFIER</b>						
*X-701	Socket-400 V. Rectifier Tube	4 Pin Bayonet-Medium	S# 552120	1	7616537 PT-341	3		
X-702	Socket-400 V. Rectifier Tube	Same as X-701			7616537 PT-342			
X-703	Socket-2500 V. Rectifier Tube	Part of T-706			7616537 PT-343			
X-704	Socket-2500 V. Rectifier Tube	Part of T-707			7616537 PT-344			
X-705	Socket-2500 V. Rectifier Tube	Part of T-708			7616537 PT-345			
X-706	Socket-2500 V. Rectifier Tube	Part of T-709			7616537 PT-346			
X-707	Socket-2500 V. Rectifier Tube	Part of T-710			7616537 PT-347			
X-708	Socket-2500 V. Rectifier Tube	Part of T-711			7616537 PT-348			
*X-709	Socket-Left Driver Tube	5 Pin	HX-100	5	7616537 PT-349			
X-710	Socket-Right Driver Tube	Same as X-709			7616537 PT-350	3		
*X-711	Socket-Left 3 Kw. Amplifier			1	7716968 G-1	2		
X-712	Socket-Right 3 Kw. Amplifier	Same as X-711			7616537 PT-352			
X-718	Socket-Lamp	660 Watts, 250 V.	# 400	8	7616537 PT-358	1		
X-719	Socket-Fluorescent Lamp	110-125 V. Miniature Bipin	# 4330-W	8	7616537 PT-359	3		
X-720	Socket-For K-713	Same as X-201			7616764 PT-361			
X-721	Socket-For K-714	Same as X-201			7616764 PT-362			
X-722	Socket-For K-715	Same as X-201			7616764 PT-363			
X-723	Socket-For K-716	Same as X-201			7616764 PT-364			
X-724	Socket-For K-717	Same as X-201			7616764 PT-365			
X-725	Socket-For K-718	Same as X-201 (See Note 4)			7616764 PT-366			
X-726	Socket-Spare	Same as X-201 (See Note 4)			7616764 PT-367			
X-727	Socket-2500 V. Rectifier Tube Spare	4 Pin Bayonet-Jumbo	S# 552123	1	7616771 PT-457	1		
X-728	Socket-400 V. Rectifier Tube Spare	Same as X-701			7616771 PT-458			
X-729	Socket-Driver Tube Spare	Same as X-709			7616771 PT-459			
*X-730	Socket-Lamp Starter	8 Watt Fluorescent Lamp Starter Socket (See Note # 5)	# 4309	8	7616771 PT-460	3	1	
X-731	Socket-Lamp Starter	Same as X-730 (See Note # 5)			7616771 PT-461			
X-732	Socket-Lamp Starter	Same as X-730 (See Note # 5)			7616771 PT-462			
X-733	Socket-For K-718	Same as X-201 (See Note # 4)			7619743 PT-491			

PARTS AND RECOMMENDED SPARE PARTS LIST						PER UNIT	RECOM'D SPARE PARTS LIST	MINIMUM SPARE PARTS LIST
CIRCUIT SYMBOL	FUNCTION	DESCRIPTION	STYLE OR CAT. NO.	MFG.	WESTINGHOUSE DRAWING NO.			
Y-401	Crystal for Crystal Oscillator Filament Connectors for WL473's <del>Air Filter, (Air Maze Corp. Type R-82, Panel Size 12 x 16 x 3/4 Tk.)</del> Resistor Clip Insulator Belt for Blower, (Browning Supercord Belt. Outside Lg 26 In.)	TYPE MY UNIT Order from Bliley Electric Co. in Accordance with Dwg. 7425667			7425667	2		
				1	7427741 G-1	8	2	2
			Type R-82	1	7423090 PT-355	1	1	1
				1	7610465 PT-3	16	2	2
				1	7409873 PT-1	14	2	2
			FHP 124	1	7619597 PT-8	1	1	1
<p><b>NOTES:</b> 1 Ballast 58G649 used on all sets after SGR No. 56792.</p> <p>2 K718 is on sets Ser. No. 56758 to 56797 only. K722 is on all sets thereafter.</p> <p>3 On sets after Ser. No. 56797. M 703 Scale is 0-100 M.A.D.C.</p> <p>4 Sockets X725 and 726 are on sets. Ser. No. 56758 to 56797 only. Sockets X733 is on sets after Ser. No. 56797 only.</p> <p>5 Sockets X730, X731, X732 used on sets after Serial No. 56792 Items with Style or Cat. No. beginning "JAN" may be obtained from any supplier whose components meet joint Army-Navy specifications. Omit Government Qualification and Sampling Tests.</p> <p>* Items so marked on this list are key items and must not be changed without correcting quantity columns and all items referenced.</p>								

CODE NO.	LIST OF MANUFACTURERS	
	NAME	ADDRESS
1	Westinghouse Elec. Corp.	2519 Wilkens Ave., Baltimore, Md.
2	Sturtevant Company	37 Readville, Hyde Park, Boston, Mass.
3	Aerovox Corp.	New Bedford, Mass.
4	Hammarlund Mfg. Co.	424 W. 33rd St., New York, N. Y.
5	National Co.	61 Sherman Street, Malden, Mass.
6	Allen D. Cardwell Mfg. Co.	81 Prospect St., Brooklyn, N. Y.
7	Littelfuse Co.	4765 Ravenwood Ave., Chicago, Illinois
8	Bryant Electric Co.	1421 State Street, Bridgeport, Conn.
9	Price Bros.	332 E. Church St., Frederick, Md.
10	Carborundum Co.—Globar Div.	C. P. Knupfer Bldg., Niagara Falls, N. Y.
11	Micro Switch Corp.	Freeport, Ill.
12	R.C.A. Victor Div. of R.C.A.	Camden, N. J.
13	Eitel McCullough (EIMAC)	San Bruno, California
14	American Phenolic Co.	1250 W. Van Buren St., Chicago, Ill.
15	Hugh H. Eby, Inc.	4700 Stenton Ave., Philadelphia, Pa.
16	Holtzer-Cabot Co.	125 Armory St., Boston, Mass.
17	James Millen Mfg. Co.	150 Exchange St., Malden, Mass.
18	Chicago Telephone Supply Co.	Elkhart, Indiana
19	Automatic Electric Co.	1033 W. Van Buren St., Chicago, Ill.
20	Superior Electric Co.	32 Harrison St., Bristol, Conn.
21	Cannon Electric Co.	3291 Humboldt St., Los Angeles, Calif.
22	General Electric Co.	Schenectady, N. Y.
23	Acro Electric Co.	1305 Superior Ave., Cleveland, Ohio
24	Oak Mfg. Co.	1260 Clybourn Ave., Chicago 10, Ill.
25	C. P. Clare Co.	4719 W. Sunnyside Ave., Chicago 30, Ill.
26	Ohmite Mfg. Co.	4835-55 Flournoy St., Chicago, Ill.
27	E. F. Johnson Co.	Waseca, Minn.
28	H. B. Jones	2460 W. George St., Chicago, Ill.
29	Centralab Div. of Globe-Union, Inc.	Milwaukee 1, Wisconsin
30	F. W. Sickles	300 Main St., Springfield, Mass.
31	North American Phillips Co., Inc.	100 E. 42nd St., New York 17, N. Y.
32	Erie Resistor Corp.	Erie, Pa.
33	J. W. Miller Co.	
34	International Resistance	401 N. Broad St., Philadelphia 8, Pa.
35	Allen-Bradley	Milwaukee, Wisconsin
36	Ucinite Co.	Newtonville, Mass.

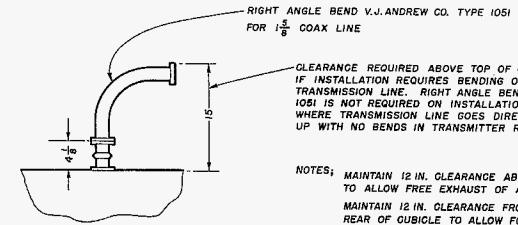
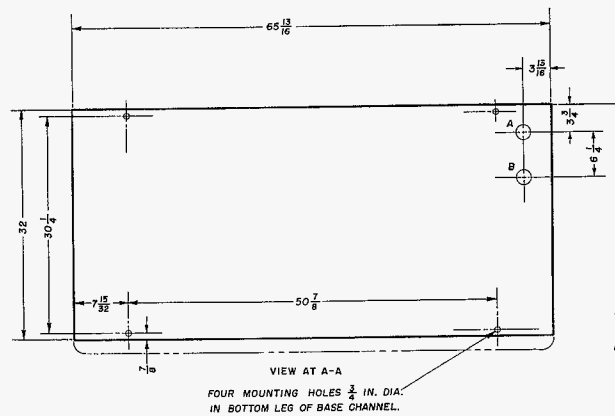
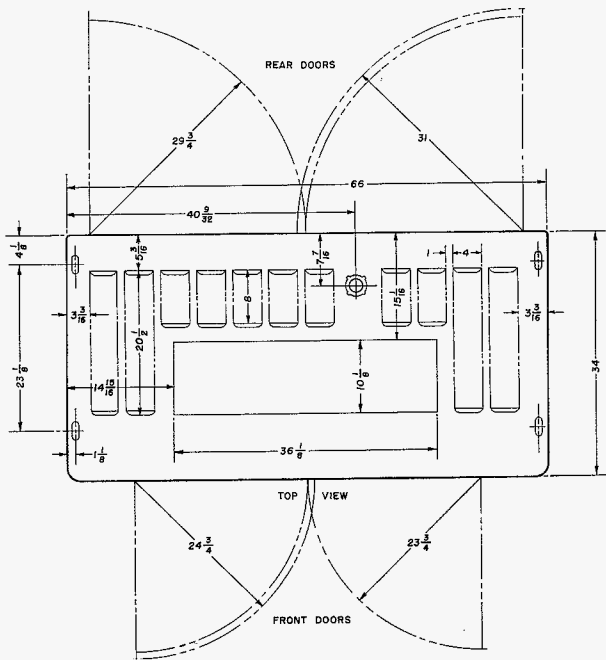

VIEW SHOWING RIGHT ANGLE BEND

- NOTES:
- MAINTAIN 12 IN. CLEARANCE ABOVE CUBICLE TO ALLOW FREE EXHAUST OF AIR.
  - MAINTAIN 12 IN. CLEARANCE FROM BOTTOM OF REAR OF CUBICLE TO ALLOW FOR FREE FLOW OF AIR TO INTAKE APERTURES. KEEP FLOORS CLEAR OF DEBRIS AND DUST.
  - SEAL BOTTOM OF CUBICLE TO FLOOR WITH LAYKOLD FLOOR MASTIC 8-12 SPEC. BUY FROM - AMERICAN BITUMULS CO. P.O.-1955 BALTIMORE 3, MARYLAND.
  - "A" KNOCKOUT FOR 1 1/2 IN. POWER CONDUIT. 230 VOLTS 3Φ 10 KVA POWER 115 VOLTS 1Φ 25 VA CRYSTAL HEATERS 115 VOLTS 1Φ LIGHTS AND UTILITY OUTLET. EXTERNAL SWITCH REQUIRED.
  - "B" KNOCKOUT FOR 1 1/2 IN. CONTROL CONDUIT. 1-RG-8/U CO-AX. TO MONITOR 25 #14 CONTROL WIRES 2-CONDUCTOR SHIELDED PROGRAM INPUT LINE.

OUTPUT COUPLING FOR 1 5/8 COAX LINE V.J. ANDREW CO. TYPE -1251

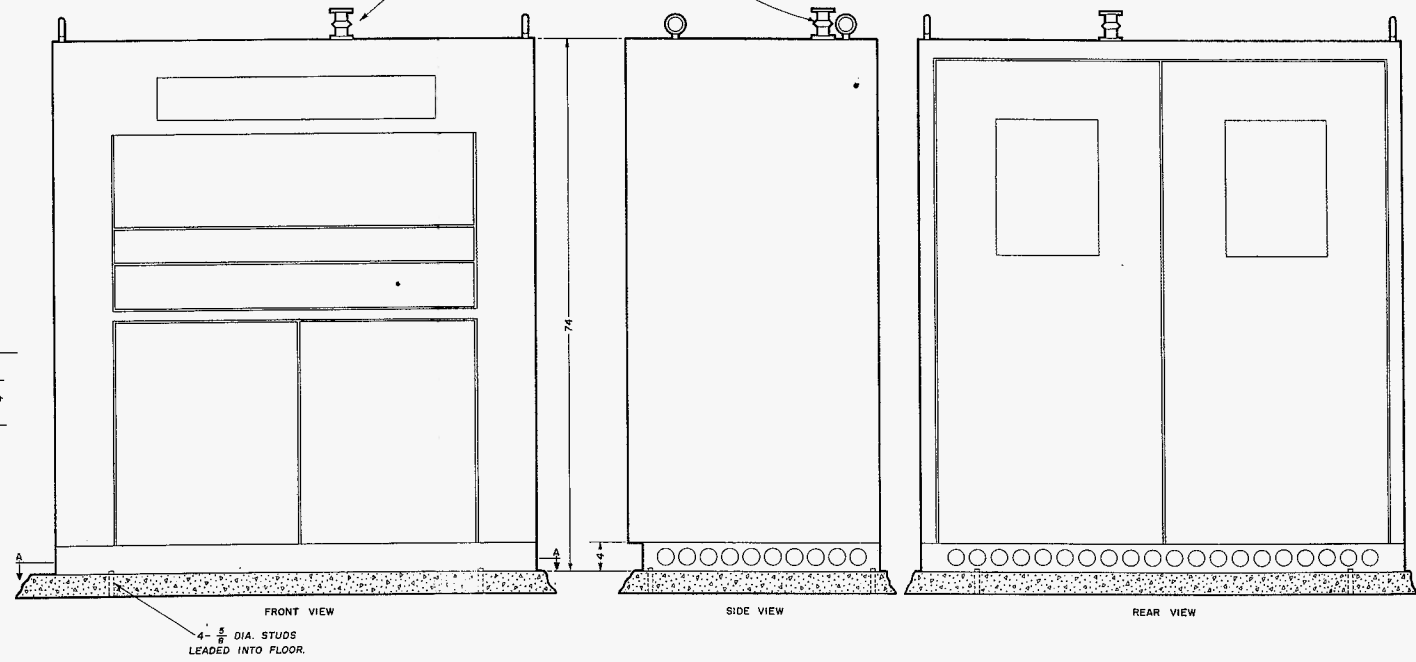

Type FM-3 Broadcast Transmitter, Cubicle Outline and Installation Drawings Figure 6-1

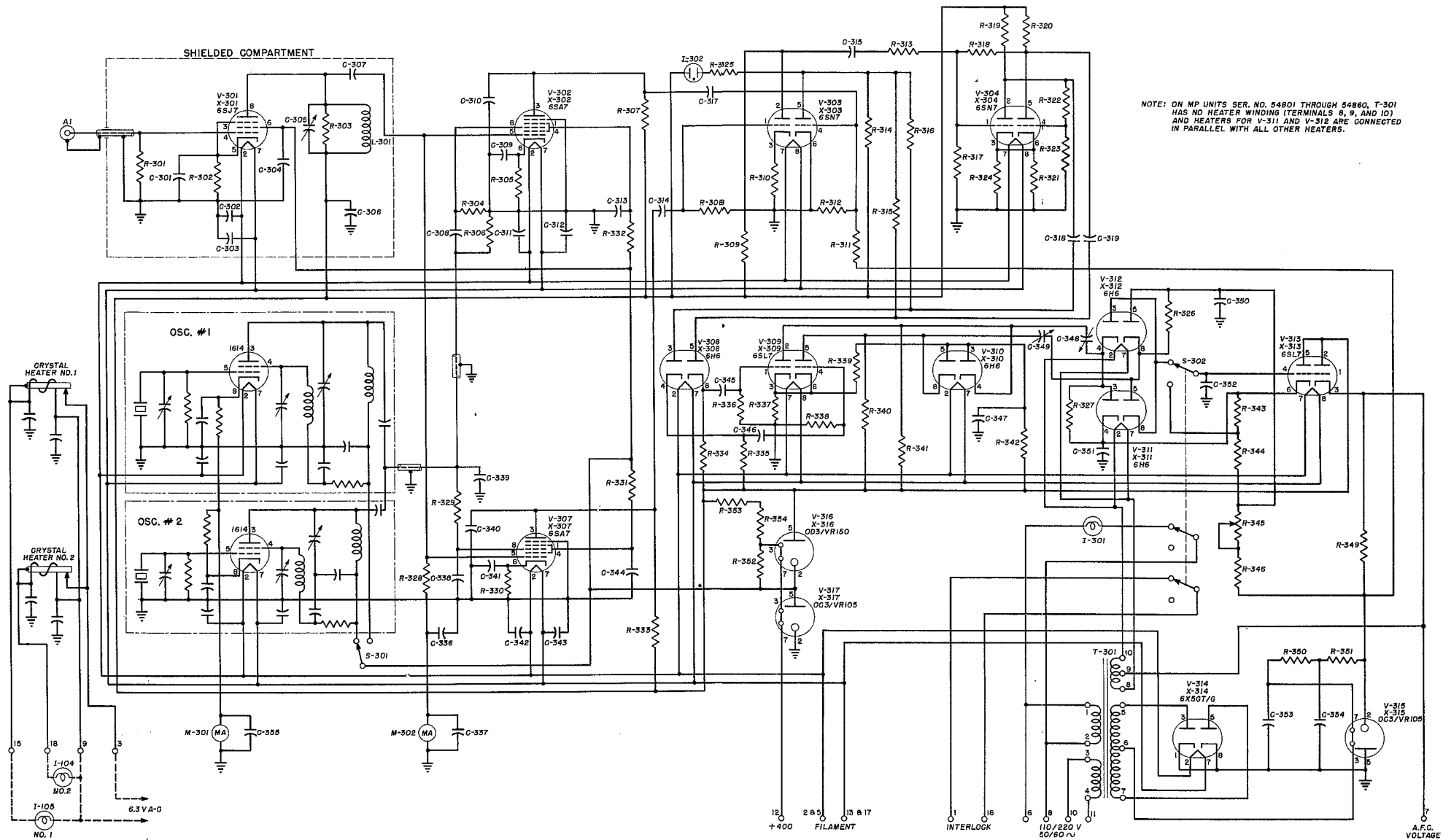

Type MP Frequency Stabilizer, Schematic Diagram  
Figure 6-4



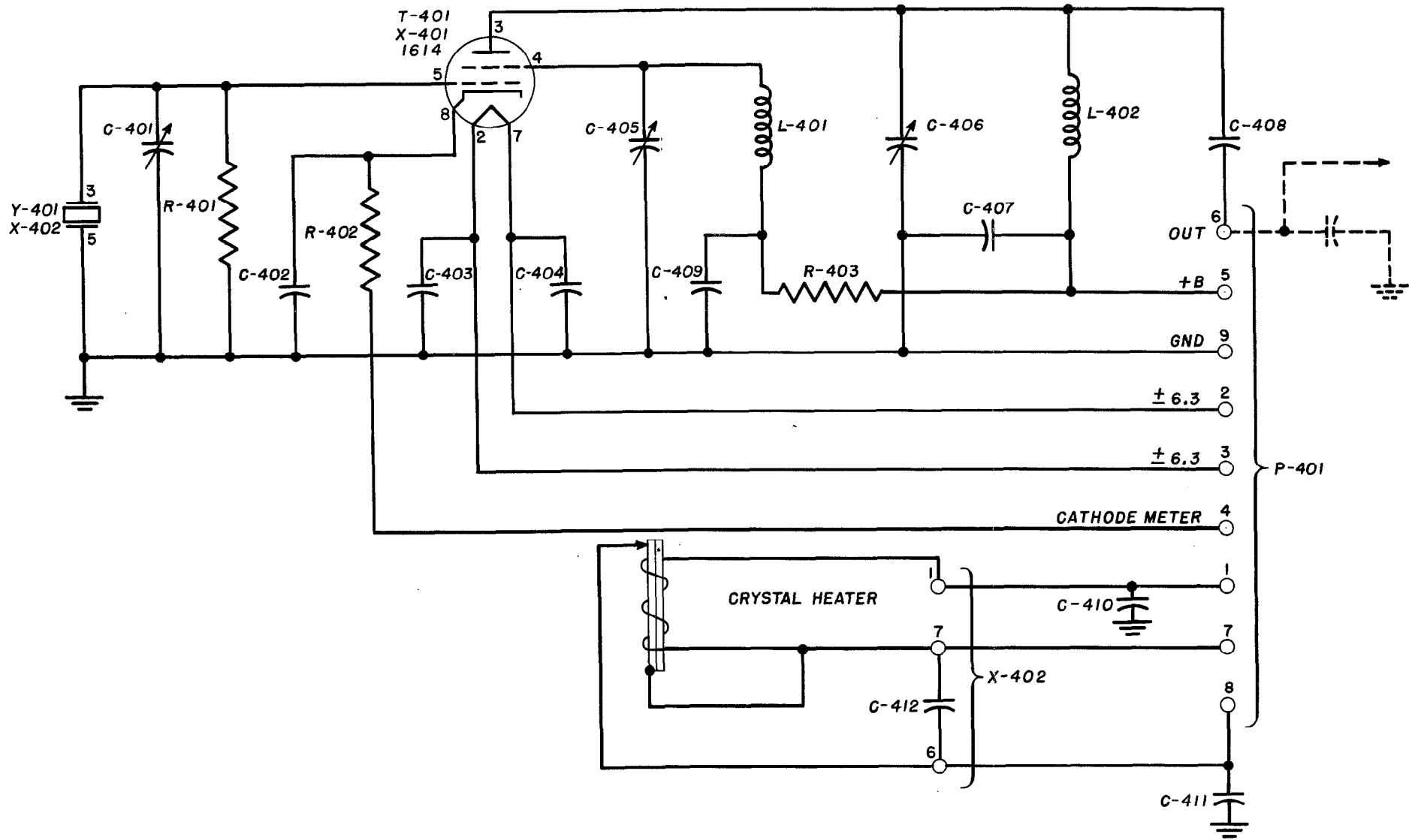

Style 1352565 Crystal Oscillator Unit, Schematic Diagram  
Figure 6-5

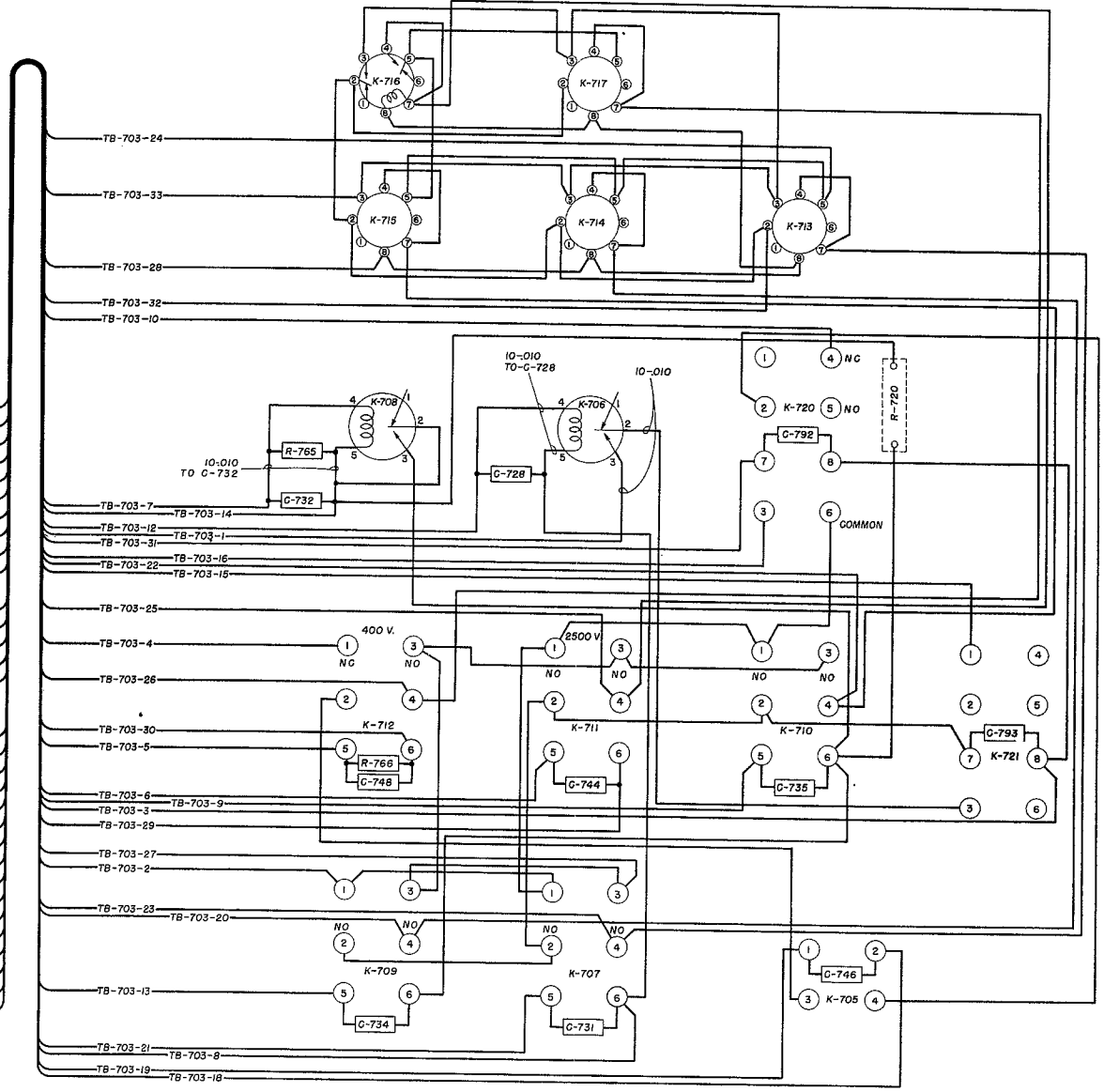
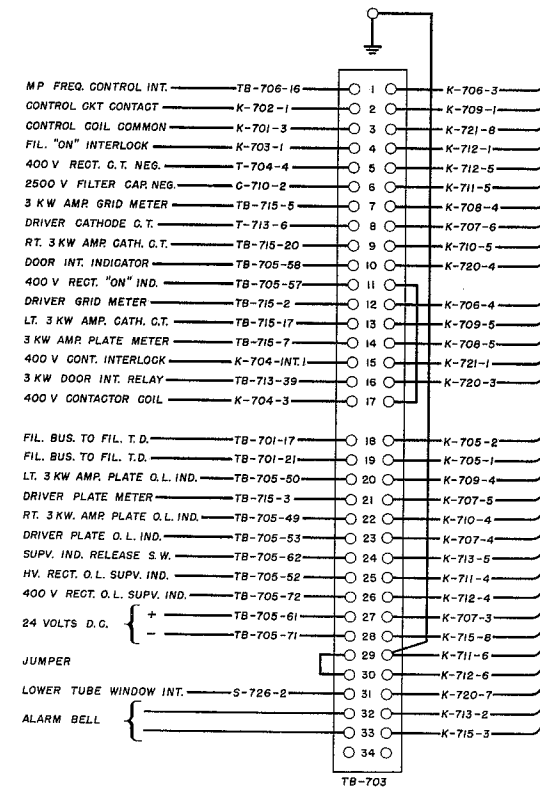

Type FM-3 Relay Panel Wiring Diagram  
Figure 6-14

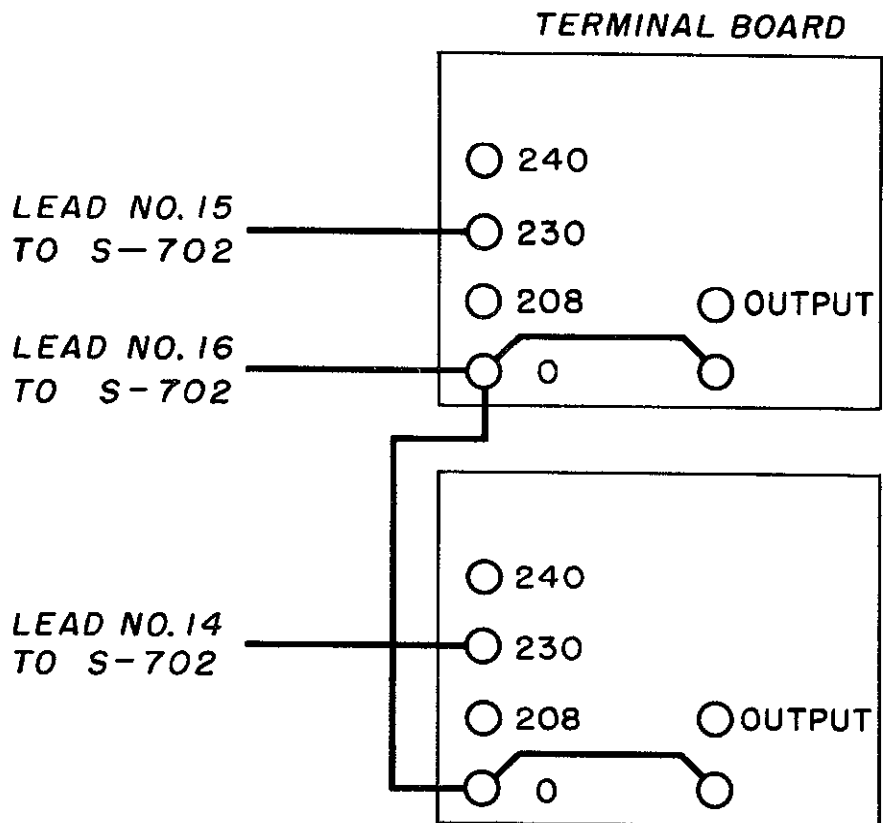

**230 VOLT LINE - NO CHANGE REQUIRED.**

**208 VOLT LINE - CONNECT LEAD NO. 15 TO TOP  
208 TERMINAL.**

**CONNECT LEAD NO. 14 TO BOT-  
TOM 208 TERMINAL.**

**240 VOLT LINE - CONNECT LEAD NO. 15 TO TOP  
240 TERMINAL.**

**CONNECT LEAD NO. 14 TO BOT-  
TOM 240 TERMINAL.**

## **T-718 DISTRIBUTION BUS REGULATOR**

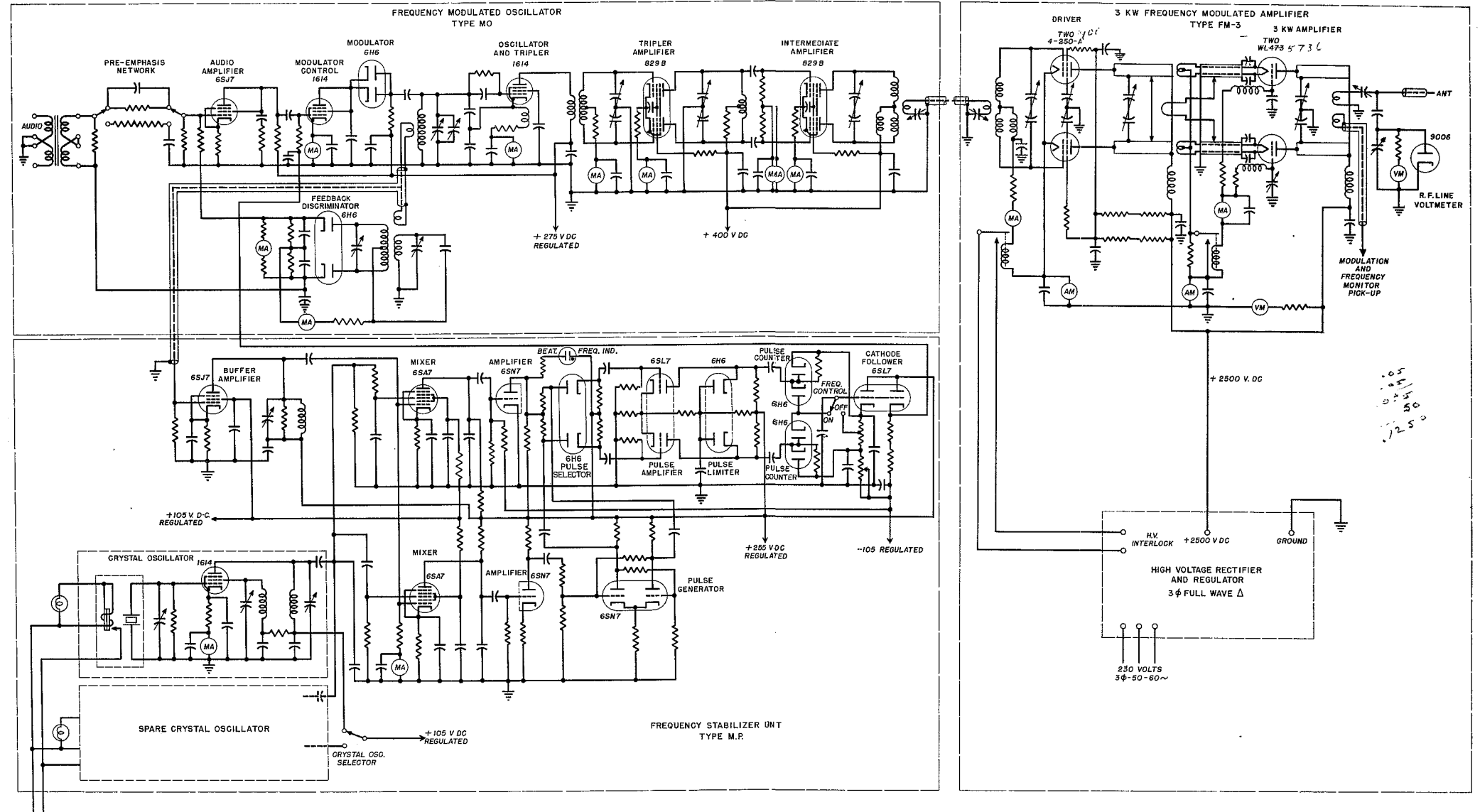

3 Kilowatt Transmitter, Schematic Diagram  
Figure 6-12

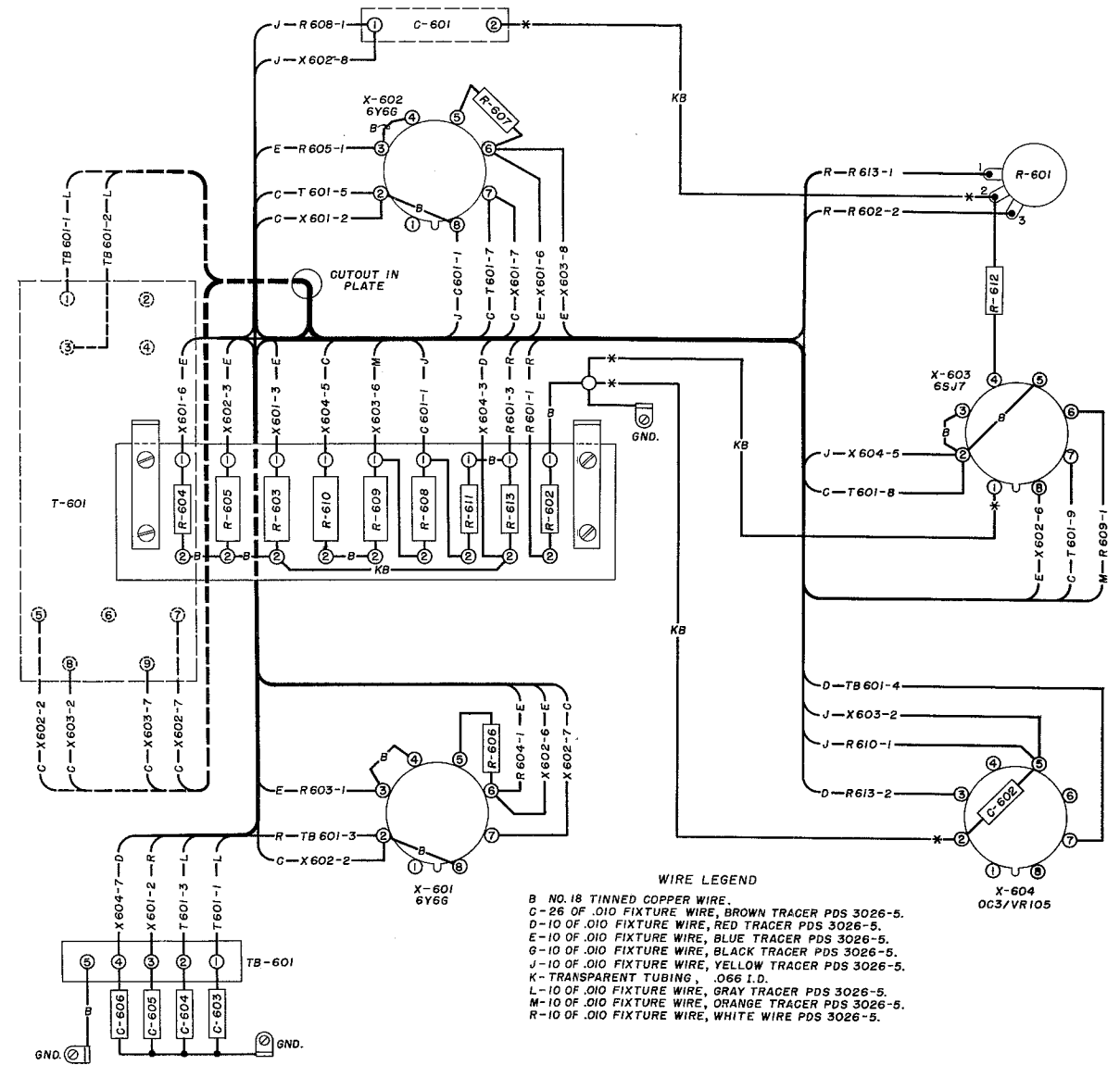

Voltage Regulator Chassis DL-7503556, G-1 Wiring Diagram  
Figure 6-10

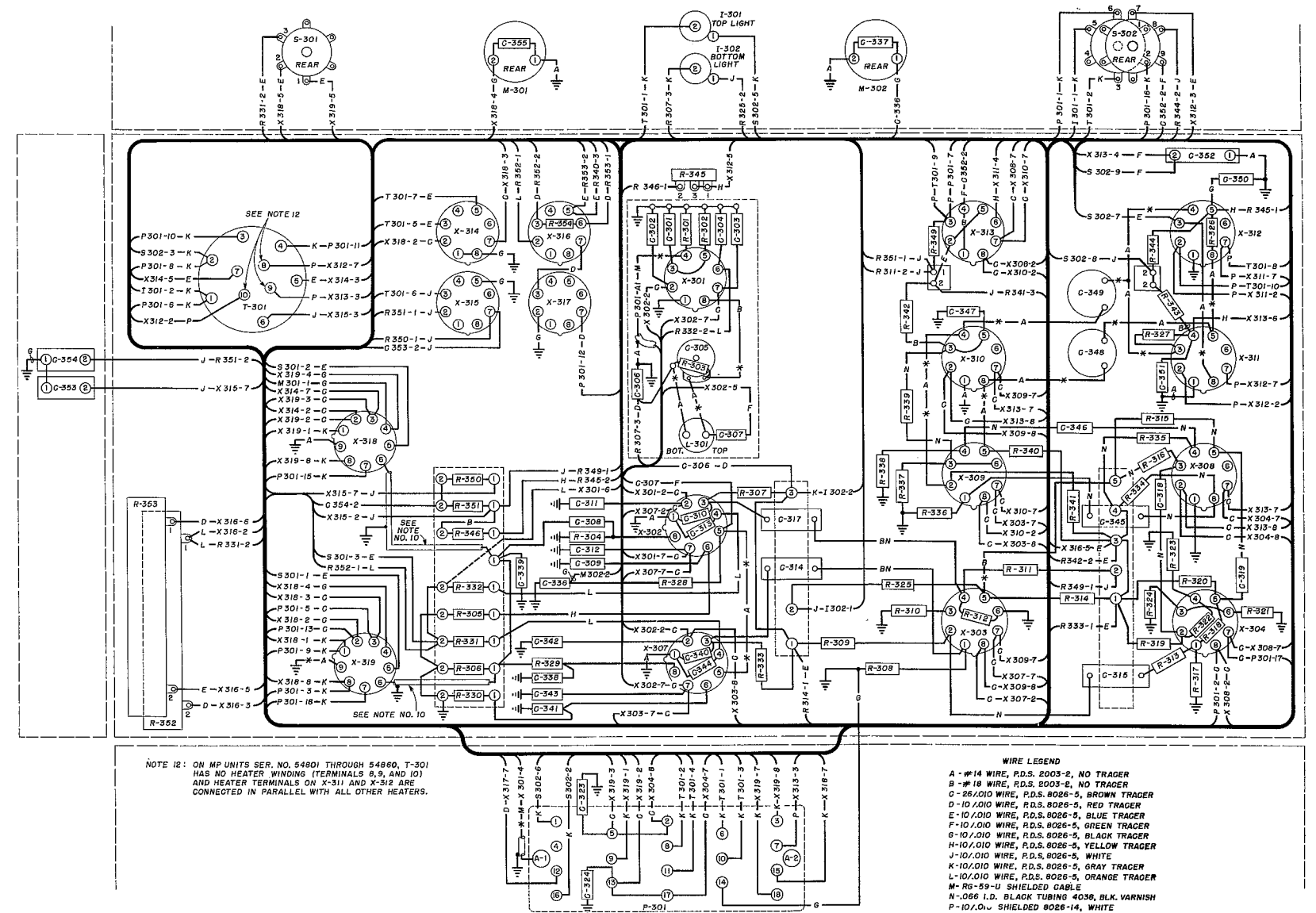

Type MP Frequency Stabilizer, Wiring Diagram  
Figure 6-9

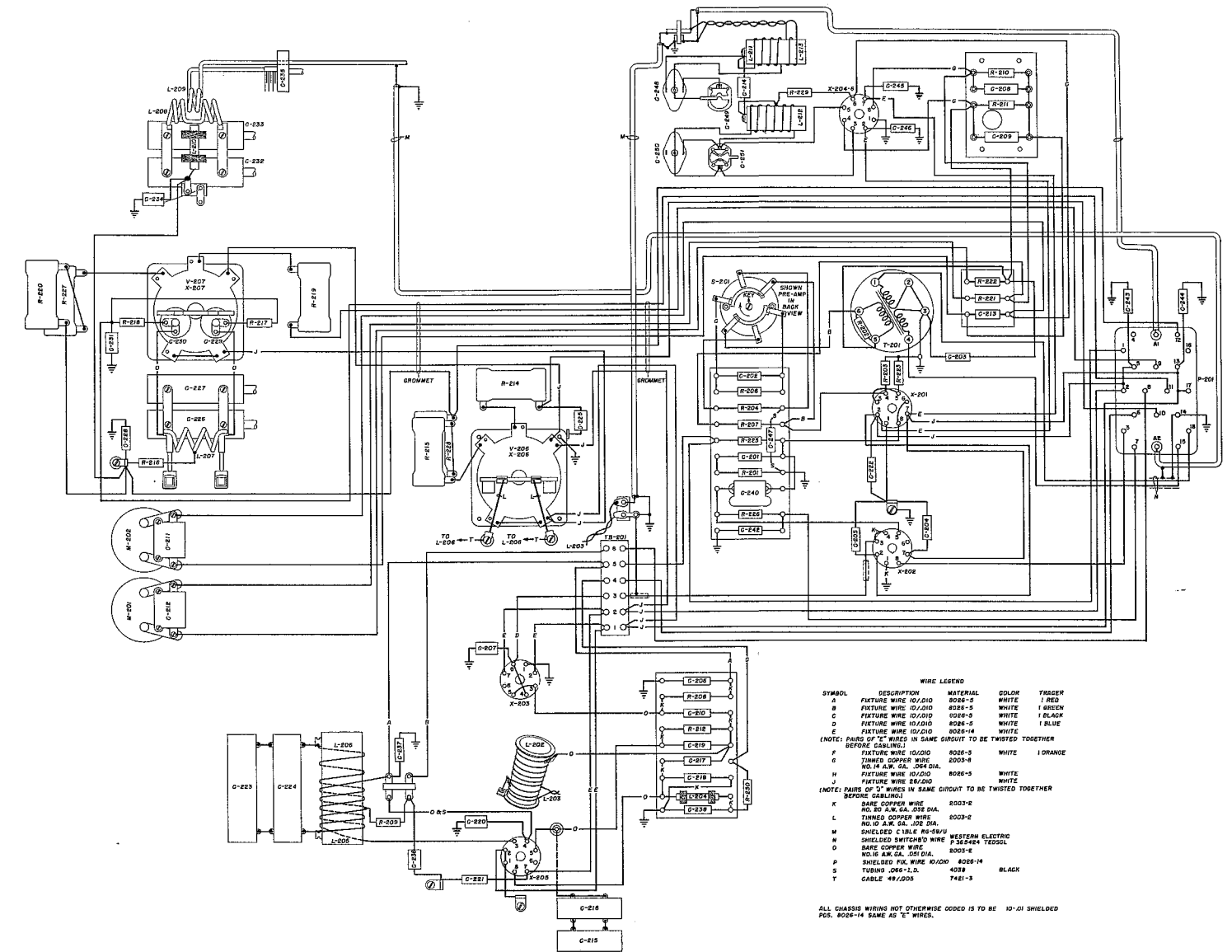

WIRE LEGEND

SYMBOL	DESCRIPTION	MATERIAL	COLOR	TRACER
A	FIXTURE WIRE 10/210	8028-S	WHITE	1 RED
B	FIXTURE WIRE 10/210	8028-S	WHITE	1 GREEN
C	FIXTURE WIRE 10/210	8028-S	WHITE	1 BLACK
D	FIXTURE WIRE 10/210	8028-S	WHITE	1 BLUE
E	FIXTURE WIRE 10/210	8028-S	WHITE	1 WHITE
(NOTE: PAIRS OF "E" WIRES IN SAME CIRCUIT TO BE TWISTED TOGETHER BEFORE CABLING.)				
F	FIXTURE WIRE 10/210	8028-S	WHITE	1 ORANGE
G	TUNED COPPER WIRE	2003-N		
H	FIXTURE WIRE 10/210	8028-S	WHITE	
J	FIXTURE WIRE 10/210	8028-S	WHITE	
(NOTE: PAIRS OF "J" WIRES IN SAME CIRCUIT TO BE TWISTED TOGETHER BEFORE CABLING.)				
K	BASE COPPER WIRE	2003-E		
L	TUNED COPPER WIRE	2003-G		
M	SHIELDED CABLE 18x18	4018		
N	SHIELDED SWITCHED WIRE	WESTERN ELECTRIC		
O	BASE COPPER WIRE	2003-E		
P	SHIELDED FUL WIRE 10/210	8028-S		
S	TURNS 106-1, 2	4018		BLACK
T	CABLE 49/1005	7421-3		

ALL CHASSIS WIRING NOT OTHERWISE CODED IS TO BE 10-21 SHIELDED PDS. 8028-S SAME AS "E" WIRES.

Type MO Frequency Modulated Oscillator, Wiring Diagram  
Figure 6-8

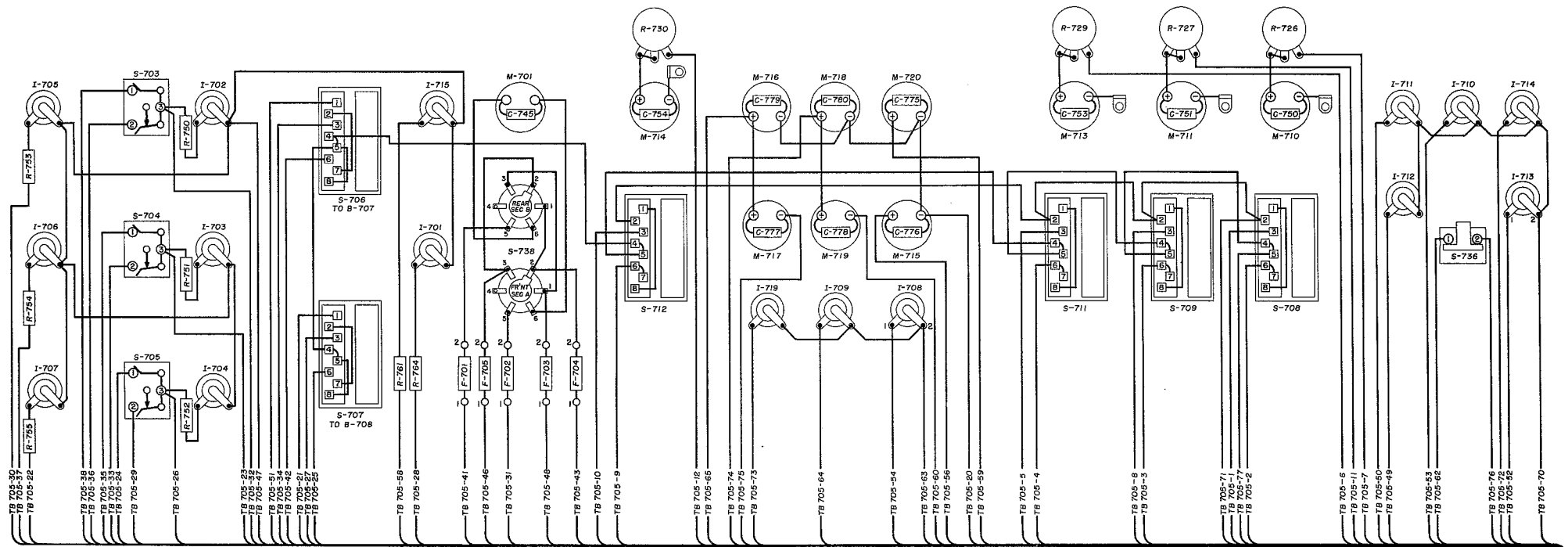

\*- INDICATES A JUMPER

1	S 708-3	DRIVER GRID TUNING MAX., TB 708-2
2	S 708-6	DRIVER GRID TUNING MIN., TB 708-1
3	S 709-6	DRIVER PLATE TUNING MIN., TB 709-1
4	S 711-6	3 KW AMP. PLATE TUNING MIN., TB 711-1
5	S 711-3	3 KW AMP. PLATE TUNING MAX., TB 711-2
6	R-729	3 KW. POTENTIOMETER, TB 711-5
7	R-726	DRIVER GRID POSITION, TB 708-5
8	S 709-3	DRIVER PLATE TUNING MAX., TB 709-2
9	S 712-6	3 KW. AMP. OUTPUT MIN., TB 712-1
10	S 712-3	3 KW. AMP. OUTPUT MAX., TB 712-2
11	R-727	DRIVER PLATE POSITION, TB 709-5
12	R-730	3 KW. POTENTIOMETER, TB 712-5
13		IND. POTENTIOMETER
14		
15		
16		
17		
18		
19		
20	M 715 (-)	CONTROL PANEL CUBICLE GROUND
21	S 707-1	REMOTE MOTOR TUNING, TB 716-56
22	R-725	REMOTE 2.5 KV. "ON" IND., TB 713-43
23	S 704-3	REMOTE 400 V. "READY" IND., TB 713-39
24	S 705-1	REMOTE 2.5 KV. "ON-OFF" SW., TB 713-44
25	S 707-6	REMOTE "V" RES. "RAISE" SW., TB 713-40
26	S 705-44	REMOTE 2.5 KV. "READY" IND., TB 713-45
27	S 705-3	REMOTE "V" RES. "LOWER" SW., TB 713-41
28	R-726	REMOTE AIR ON IND., TB 713-46
29	R-725	REMOTE 2.5 KV. "ON-OFF" SW., TB 713-42
30	R-753	REMOTE "FIL. ON" IND., TB 713-34
31	S 705-67	2.5 KV. REG. OUTPUT, TB 719-10
32	S 703-3	REMOTE "FIL. READY" IND., TB 713-35
33	S 705-66	REMOTE 400 V. "ON-OFF" SW., TB 713-36
34	S 704-4	REMOTE "FIL. BUS" "LOWER" SW., TB 713-31
35	S 704-1	REMOTE 400 V. "ON-OFF" SW., TB 713-37
36	S 703-2	REMOTE "FIL. ON-OFF" SW., TB 713-38
37	R-754	REMOTE 400 V. "ON" IND., TB 713-38
38	S 703-1	REMOTE "FIL. ON-OFF" SW., TB 713-33
39	S 705-42	FIL. BUS REG. MOTOR RAISE, TB 707-1
40	S 705-34	FIL. BUS REG. MOTOR LOWER, TB 707-2
41	S 705-5	2.5 KV. REG. OUTPUT, TB 719-11
42	S 705-6	REMOTE "FIL. BUS" "RAISE" SW., TB 713-30
43	F 704-1	FIL. BUS REG. OUTPUT, TB 703-L3
44	S 705-25	HK. REG. MOTOR RAISE, TB 708-1
45	S 705-27	HK. REG. MOTOR LOWER, TB 708-2
46	F 703-1	FIL. BUS REG. OUTPUT, TB 703-L2
47	F 702-1	CONTROL COIL, COMMON SIDE, TB 716-61
48	F 703-1	FIL. BUS REG. OUTPUT, TB 703-L1
49	I-712	RT. RELAY
50	I-711	LT. 3 KW. AMP. OVERLOAD, TB 703-20
51	S 706-1	REMOTE MOTOR TUNING, TB 716-57
52	I 713-1	2.5KV RECT. OL. SUPP. RELAY, TB 703-25
53	I-710	DRIVER PLATE OVERLOAD, TB 703-23
54	S 705-69	CRYSTAL HEATERS, TB 706-3
55	M 715 (+)	MOR. CONTROL CATHODE, TB 707-3
56	S 705-37	400 V. RECT. CONTACTOR, TB 703-11
57	R-726	DOOR INTERLOCK RELAY, TB 703-10
58	M 720 (+)	MODULATED OSC. CATHODE, TB 707-5
59	M 719 (-)	TRIP GRID RETURN, TB 707-8
60	S 705-76	+24 V.D.L. RELAY "MAKE", TB 703-27
61	S 705-1	+24 V. SUPP. RELAY "HOLD", TB 703-24
62	S 706-2	CRYSTAL HEATERS, TB 706-9
63	S 705-75	CRYSTAL #1 HEATERS, TB 706-15
64	S 705-78	CRYSTAL #2 HEATERS, TB 707-9
65	M 716 (+)	INT. AMP. CATHODE, TB 707-9
66	S 705-38	"AIR ON" INT'LK. SW., S 727B-1
67	S 705-30	"AIR ON" INT'LK. SW., S 727B-2
68	S 705-28	"AIR ON" INDICATOR SW., S 727A-2
69	S 705-54	CRYSTAL POWER TRANSF., T 721-5
70	S 705-71	CONTROL RELAY, #4 A.D.C. CR 701-1
71	S 705-71	SUPPLY O.L. RELAY, TB 703-28
72	S 714	400 V. RECT. O.L. SUPP., TB 703-26
73	I-719	CRYSTAL #2 HEATER, TB 706-18
74	M 718 (+)	TRIP CATHODE, TB 707-10
75	M 717 (-)	INT. AMP. GRID RETURN, TB 707-11
76	S 736-2	115 AC TUNGS. MOTOR SUPPLY, T 720-3
77	S 708-2	TRANS. AMP. CONTROL, #24 V.
78	S 708-5	SUPPLY TRANSFORMER, T 720-4
79	S 705-63	CRYSTAL POWER TRANSF., T 721-6

Type FM-3 Control Panel Wiring Diagram  
Figure 6-7



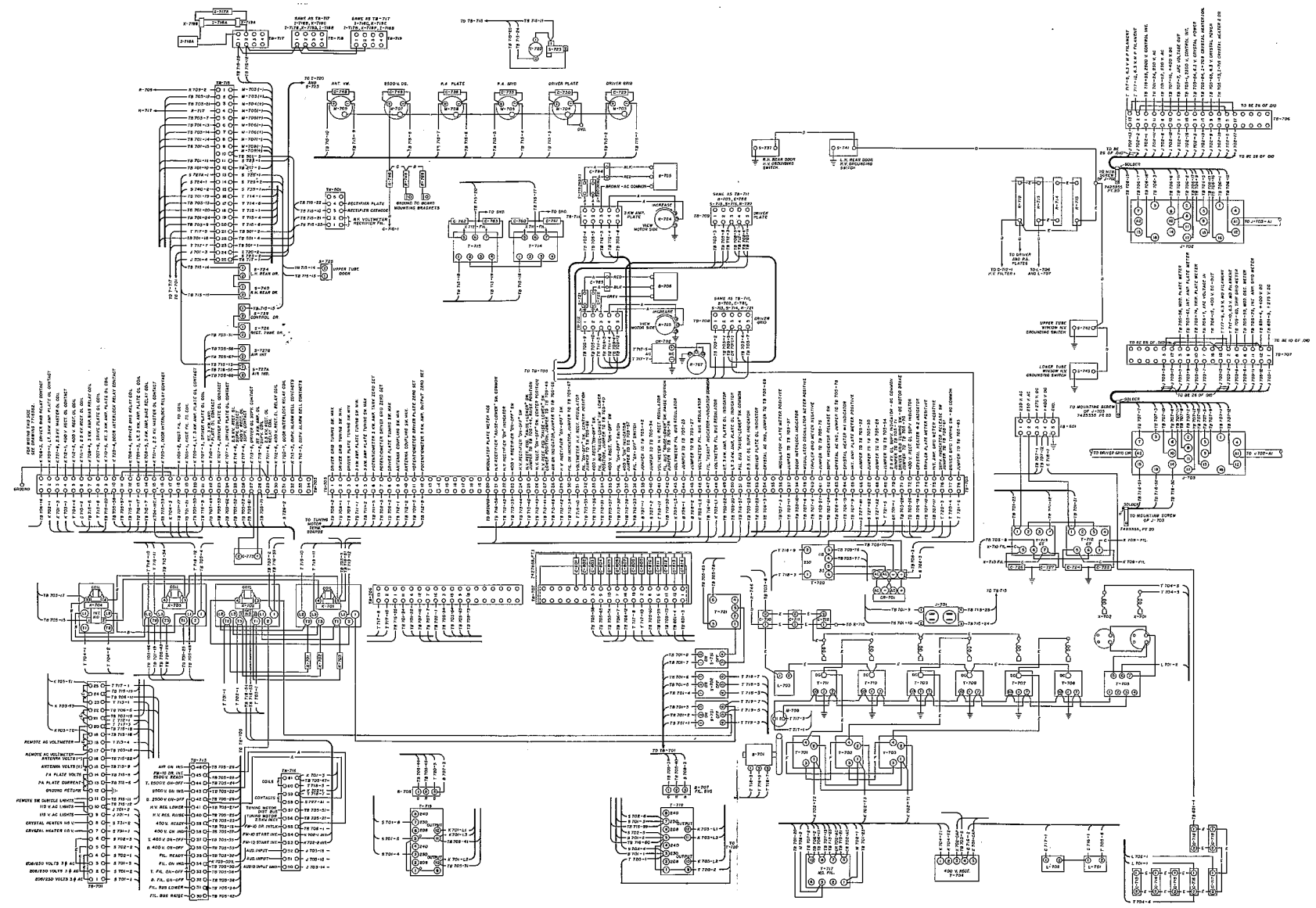

Type FM-3 Cubicle Wiring Diagram  
Figure 6-6

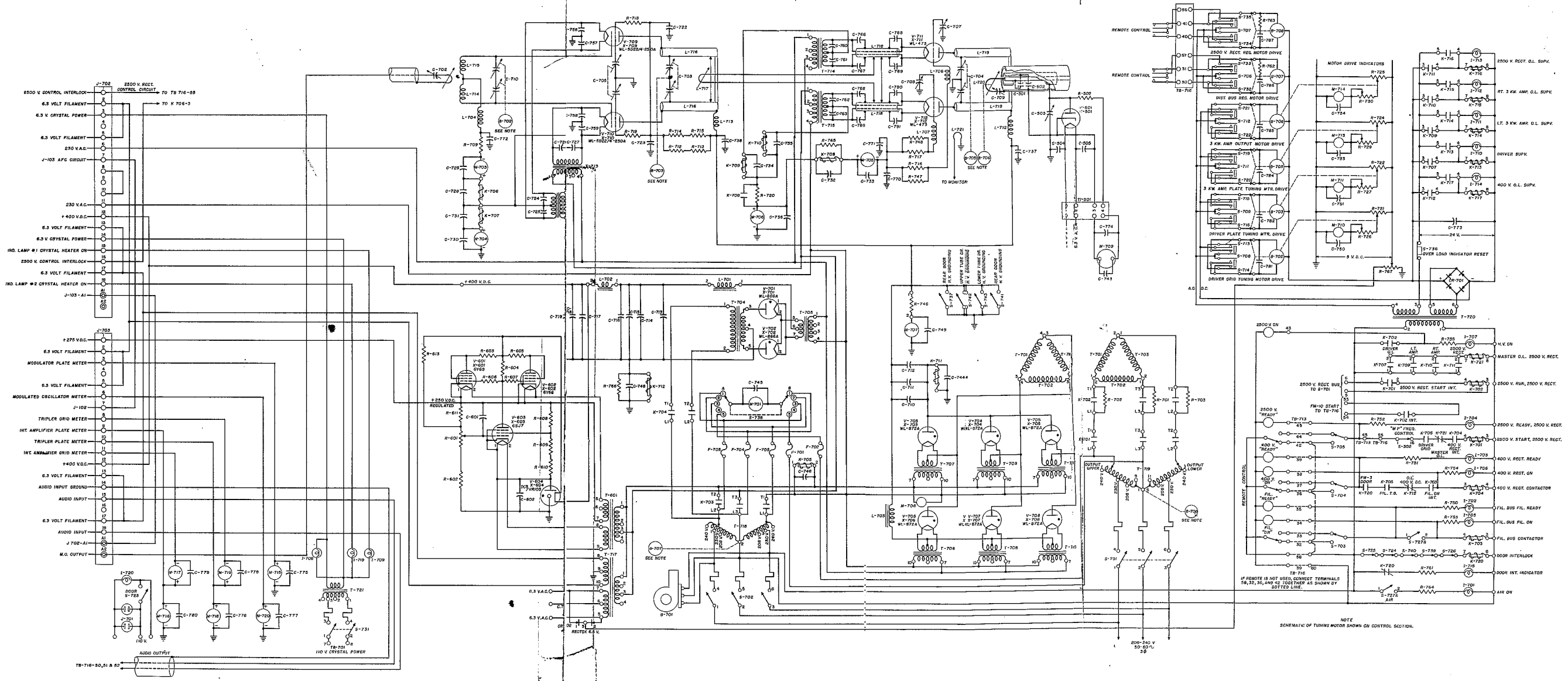

Type FM-3 Cubicle, Schematic Diagram  
Figure 6-2

