



SECTION 2

**ADVANCED
PRACTICAL
RADIO ENGINEERING**

TECHNICAL ASSIGNMENT

INDUCTIVE COUPLING

Copyright 1949 by
Capitol Radio Engineering Institute
Washington, D.C.

214 E

INDUCTIVE COUPLING

FOREWORD

The most extensively employed method of transferring electrical power from one circuit or device to another is by means of "inductive coupling". There are several basic reasons for this: first, by means of the proper "turns ratio" between two inductively coupled coils, the voltage of the energy being transferred into the second circuit can be raised or lowered as desired with the inverse effect on the current. An example of this is the common power transformer; in a radio station the power may enter over a line at 6,600 volts and then be stepped down to 440 volts for application to the radio transmitter. In the transmitter, other transformers step the voltage up or down for operation of specific transmitter functions.

Second, by means of inductive coupling, circuits which are and which are not balanced to ground may be connected together. As an example, in a radio transmitter employing a single power amplifier tube in the final stage, one end of the r-f tank circuit is effectively at ground potential. It is desired to couple this circuit to a remote antenna system over a balanced two-wire transmission line, the wires of which are at opposite potentials with respect to ground. This is accomplished by inductive coupling which effectively separates the two circuits so far as the ground effect is concerned.

Third, by means of inductive coupling a given amount of impedance in one circuit may be effectively transferred into another circuit as an entirely different value of impedance. For example, the effective resistance of an antenna may be 30 ohms. It is to be energized by a power amplifier tube which requires a load impedance of 2,400 ohms. By means of inductive coupling of the proper amount, the 30 ohms of antenna resistance can be "reflected" into the

INDUCTIVE COUPLING

amplifier r-f tank circuit as a load impedance of 2,400 ohms.

By means of the proper degree of inductive coupling between tuned r.f. circuits, the frequency response of the circuits can be made very sharp or quite broad. This principle is employed in the intermediate frequency transformers of superheterodyne receivers. If high fidelity broadcast reception is desired, the coupling is made relatively tight, and the necessary broad band of frequencies is passed. In the case of a very selective communication receiver, loose coupling and consequent sharp tuning is employed. In a television receiver the picture i-f channel must pass a band of frequencies several megacycles wide. This is accomplished by the proper selection of an intermediate frequency and the proper amount of inductive coupling in the interstage transformers.

These are just a few of the *very many* uses of inductive coupling in radio. This technical assignment will teach you the basic principles and the necessary calculations. The principles learned through careful study of this assignment will be applied throughout the course and throughout all your practical work in radio and television.

E. H. Rietzke,
President.

- TABLE OF CONTENTS -

INDUCTIVE COUPLING

	Page
SCOPE OF ASSIGNMENT	1
MUTUAL INDUCTANCE	1
<i>FUNDAMENTAL ACTION</i>	1
<i>TRANSFORMER PRINCIPLES</i>	2
<i>POLARITY RELATIONS</i>	4
<i>VECTOR RELATIONS</i>	7
IRON-CORE TRANSFORMERS	9
<i>REFLECTED IMPEDANCE</i>	9
<i>EXAMPLES OF REFLECTED IMPEDANCE</i>	10
<i>IDEAL AND ACTUAL TRANSFORMERS</i>	14
<i>BEHAVIOR OF ACTUAL TRANSFORMERS</i>	16
<i>MULTI-WINDING TRANSFORMERS</i>	18
<i>AUTOTRANSFORMERS</i>	19
AIR-CORE TRANSFORMERS	20
<i>FUNDAMENTAL CONSIDERATIONS</i>	21
<i>COMPARISON OF AIR AND IRON-CORE TRANSFORMERS</i>	21
<i>ANALYSIS OF AIR-CORE TRANSFORMER BEHAVIOR</i>	22
<i>SERIES REFLECTED IMPEDANCE</i>	24
<i>ILLUSTRATIVE EXAMPLE</i>	25
RESUME'	28

INDUCTIVE COUPLING



Courtesy RCA

The universal audio output transformer shown above has a primary designed to be connected to the plates of a pair of push-pull 6L6 beam power tubes, and a tapped secondary to connect to a loudspeaker voice coil. The wire coil impedance can be matched by connecting to the appropriate taps and will reflect the proper load to the tubes in the primary.



Courtesy RCA

This transformer is of the uncased type with flexible leads and is similar to the transformer shown at the top of the page. It is not as free from moisture, fungus and similar troubles as the potted type which is sealed in its case.

INDUCTIVE COUPLING

SCOPE OF ASSIGNMENT

In the previous assignment the phenomenon of inductance was studied and it was seen that any circuit element around which current established a magnetic field had the property of inductance, and that if the current varied, the corresponding varying magnetic field induced a counter voltage in the element tending to oppose such current and magnetic variations. The most usual form of inductance is that of a coil of wire, which may or may not be wound on an iron core. Thus, an inductance is capable of developing an opposition to the flow of a variable current, such as an alternating current, and this opposition is known as inductive reactance, to distinguish it from the ordinary resistive opposition of a resistance, or the opposition to (charging) current flow through a capacitor, known as capacitive reactance, and which will be explained in a subsequent assignment.

There is, however, one property of an inductance that is different from that observed in a resistor or capacitor, and that is the property of the varying flux inducing a counter voltage not only in the inductance itself, but in neighboring conductors. In turn, variable currents in the latter can also induce a voltage in the inductance under consideration, hence the phenomenon is known as MUTUAL inductance, in contradistinction to the SELF inductance of the coil itself.

In this assignment the property

of mutual inductance will be analyzed, and its applications to close-coupled and loosely-coupled transformers will be studied. Thus, the behavior of a-f iron-core and r-f air-core transformers will be discussed, as well as their uses in vacuum-tube and other communication circuits.

MUTUAL INDUCTANCE

FUNDAMENTAL ACTION.—In Fig. 1

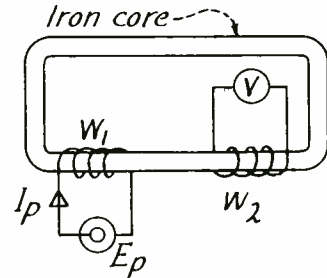

Fig. 1.—Two coils mounted on a common iron core.

are shown two coils of wire W_1 and W_2 arranged so that they are close together and on a common iron core. Assume that the permeability of the iron core is so high that practically all the magnetic flux set up in the core by one coil passes through the other coil.

Now suppose a sine-wave alternating voltage E_p of a frequency f

is impressed on the coil W_1 . (For simplicity assume W_1 has no resistance.) A corresponding a-c current I_p is caused to flow in W_1 , of such magnitude as to set up an a-c flux which in turn induces a counter voltage in W_1 that just balances E_p . Equilibrium conditions therefore exist; the current flow has built up to a value whereby the counter electromotive force induced is equal and opposite to E_p , and the current cannot build up to a higher value than this for otherwise the c.e.m.f. will exceed the impressed electromotive force.

As shown in the previous assignment, the holding in check of the current by the action of the flux inducing a c.e.m.f. is designated as a reactance effect; inductive reactance in the case of a coil. Its value is given very simply by

$$X_L = 2\pi fL \quad (1)$$

as was shown in a previous assignment. The symbol L represents the self inductance of the coil and is measured in henries.

The current flow is then given very simply by

$$I_p = E_p / X_L = E_p / 2\pi fL \quad (2)$$

and if E_p is the r.m.s. value of the voltage, I_p is the r.m.s. value of the current.

However, the actual mechanism whereby this reactance is produced was just shown to reside in the a-c flux; it is the variations in the latter (rate of change with time) that induce the c.e.m.f. The question naturally arises, "Why can't this same varying flux induce a voltage in any other coil of wire that it happens to pass through?"

The answer is, "It can." Thus, a voltage is induced in coil W_2 as in coil W_1 , since the flux has been assumed to pass through both in traversing the high-permeability iron core. The voltage induced in W_2 cannot be termed a c.e.m.f. since it is the only voltage present in W_2 and therefore not opposing any other voltage (as is the case in coil W_1) but it may be referred to as a secondary voltage and W_2 as a secondary coil, whereas W_1 would be called a primary coil. The arrangement, including the iron core, is known as a transformer, and the two coils are said to be magnetically coupled and therefore to have MUTUAL INDUCTANCE.

TRANSFORMER PRINCIPLES.—The magnitude of the secondary voltage can be read by the vacuum-tube voltmeter V in Fig. 1. It can also be very readily calculated under the simplifying assumptions made, namely, that the circuit has zero resistance so that the only limitation to current flow is the inductive reactance of W_1 and further that all the flux linking W_1 also links W_2 .

Thus, the amount of flux set up is just sufficient to induce a c.e.m.f. in W_1 that is equal and opposite to E_p . Suppose W_1 has N_1 turns. Then if E_p volts are induced across all N_1 turns in series, E_p/N_1 volts are induced in each turn. Now if W_2 has N_2 turns, the flux will induce E_p/N_1 volts in each turn, or a total of $(E_p/N_1) N_2$ volts in the entire N_2 turns of W_2 . As a special case, if $N_2 = N_1$ (W_2 has the same number of turns as W_1) the voltage induced in W_2 will be the same as that induced in W_1 , namely E_p volts.

As a simple illustrative example (See Fig. 2) suppose 10 volts ($=E_p$) are impressed across W_1 . Then a certain current I_p will flow in W_1 ,

this will set up a certain amount of flux, and the latter in turn will induce in W_1 a c.e.m.f. of 10 volts opposite in phase to the 10 volts impressed.

Assume W_1 has 20 turns. Then

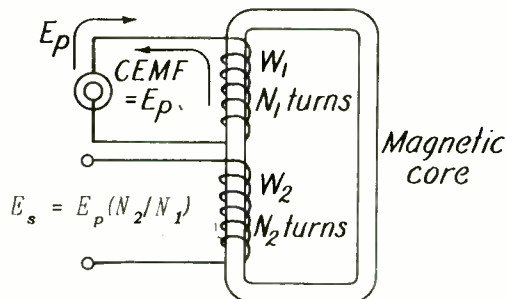

Fig. 2.—The flux set up by the primary also links the secondary and induces voltage E_s in it, as well as a c.e.m.f. in the primary that is equal and opposite to E_p .

the voltage induced per turn will be $10/20 = 1/2$ volt. Now if the flux links in its entirety coil W_2 , it will induce $1/2$ volt in each turn of W_2 . If W_2 has 20 turns the voltage induced in W_2 will be $20 \times 1/2 = 10$ volts, the same as that induced in W_1 .

If W_2 has 50 turns, the voltage induced will be $50 \times 1/2 = 25$ volts, or higher than that induced in W_1 (and also higher than E_p impressed across it). On the other hand, if W_2 has only 5 turns the voltage induced in it will be $5 \times 1/2 = 2\ 1/2$ volts, or less than that induced or impressed across W_1 . This illustrates the fundamental transformer action: the two coils coupled together can transform an impressed voltage E_p across one coil into a higher, lower or equal voltage induced in the other coil, and this is a very useful and important property as will be illustrated

farther on.

As indicated previously, the coil across which the voltage is applied is called the PRIMARY of the transformer; the other coil in which a voltage is induced is called the SECONDARY of the transformer. Thus in the above example, W_1 is the primary and W_2 is the secondary. From the analysis just given, however, it should be clear that the generator could be connected to W_2 making it the primary, whereupon W_1 would become the secondary. Thus, which is the primary and which is the secondary is purely a matter of which winding receives the energy from an external source.

Suppose, as before, that W_1 is the primary. Then if W_2 has more turns than W_1 ($N_2 > N_1$), the secondary voltage will be greater than the primary voltage E_p , or the device will be a STEP-UP transformer. On the other hand, if W_2 is made the primary and W_1 the secondary, the same unit will act as a STEP-DOWN transformer in that the voltage induced in W_1 will be less than E_p applied to W_2 . Hence a transformer can be either step-up or step-down depending upon which is made the primary and which is made the secondary winding.

Another point to note is that more than one secondary can be wound on the same core; the varying flux, in traversing each winding, will induce a voltage in the winding depending upon its number of turns. Thus, the voltage may be stepped up in one secondary and stepped down in another.

As an example, refer to Fig. 3 where a power-supply transformer for a television receiver is shown. The primary is connected to the 110-volt a-c power supply. Secondary S_1 has

many more turns, so that 600 volts are developed across the entire winding. At the midpoint of the winding is soldered a connection C; the voltage from either end to C is $600/2 = 300$ volts, as indicated. Tap C is known as a center tap. Winding S_1 furnishes the high voltage which, after rectification, becomes the d-c plate-supply potential for the various amplifier tubes. (Power supplies will be thoroughly discussed in a subsequent assignment.)

Secondary S_2 is also a center-tapped winding furnishing 6.3 volts from either end to the center tap (which is grounded), or a total of 12.6 volts. One-half of the winding feeds the heaters of the r-f and i-f amplifier tubes; the other half supplies the video, audio, and deflection amplifier tubes. Secondary S_3 furnishes 5 volts for the filament of the rectifier tube that converts the a-c of S_1 into d-c for the plates of the various amplifier tubes, and S_4 furnishes the 5 volts required for the heater of the diode-damping tube employed in the horizontal deflection circuit to damp out circuit transients. The reason a separate secondary is employed instead of S_3 is that the latter is at the full B^+ potential to ground, and furthermore, S_4 is wound spaced from the primary by insulating strips so as to decrease the capacity of this winding to ground—a requisite for proper deflection wave shape.

POLARITY RELATIONS.—So far the discussion has concerned itself with the voltage relations existing in a system where two or more circuits are magnetically coupled to one another. It will now be of interest to examine the current and power relations, and the vector method of

representation will be found to be a powerful and compact way of exhibiting these relations.

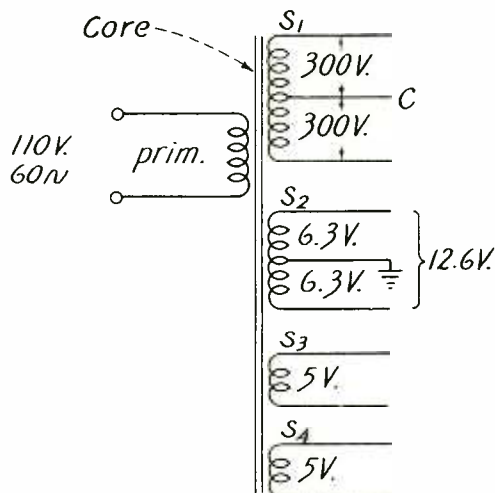

Fig. 3.—Power transformer used in a television receiver.

Consider once more the arrangement shown in Figs. 1 or 2. The voltage E_p is impressed across W_1 ; a voltage E_s is induced in W_2 equal to E_p multiplied by the ratio of the secondary number of turns N_2 to the primary number of turns N_1 ; this is,

$$E_s = E_p (N_2/N_1) \quad (3)$$

If there is a voltage induced in W_2 , a current will flow if an impedance, such as a resistance, is connected across W_2 . Let a resistance R_L be so connected. Then the current flow will be

$$I_s = E_s/R_L \quad (4)$$

However, the moment I_s starts to flow in W_2 , it begins to set up a counter magneto-motive force (c.m.m.f.) in the core which tends to reduce the magnetic flux there.

The reason is that the voltage

induced in any winding by the flux is always in the direction such that if it can cause current to flow, the current will tend to oppose the setting up of the flux. Thus, in the primary itself the induced voltage is a c.e.m.f.; it opposes the impressed voltage and tries to set up a current flow opposite to that produced by the impressed voltage. (Lenz's Law).

In the case of a secondary winding, the induced voltage is the only

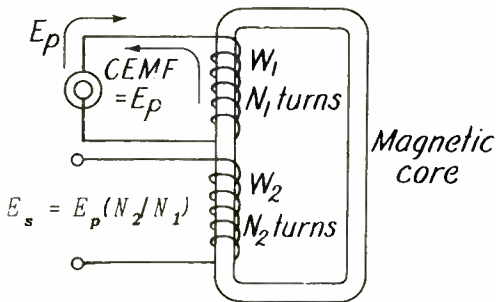

Fig. 2.—The flux set up by the primary also links the secondary and induces voltage E_s in it, as well as a c.e.m.f. in the primary that is equal and opposite to E_p .

voltage present, and it produces a current flow in the winding in such direction as to tend to oppose the primary current and hence to decrease the flux in the core. However, the moment the flux tends to decrease, the primary c.e.m.f. tends to decrease, and this in turn permits the impressed primary voltage to predominate to an even greater extent, so that it can force an *ADDITIONAL* current through the primary winding. This *ADDITIONAL* primary current assumes a magnitude and phase just equal and opposite in its effect to that of the secondary current, balancing its demagnetizing effects and permitting the flux to remain prac-

tically unchanged; i.e., the decrease in flux mentioned previously is but infinitesimal.

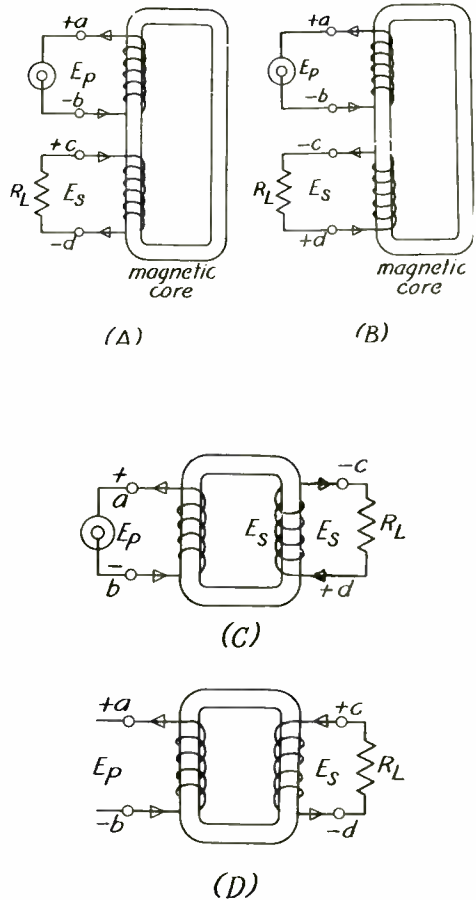

Fig. 4.—Relative polarities of primary and secondary voltages for various winding arrangements. (The electron flow from - to + is used here.)

Before presenting the above information in vector form, it will be of value to discuss for a moment the polarity of the induced secondary voltage. In Fig. 4 (A), both primary and secondary coils are wound on the same leg of the coil, and in the same direction. (Same sense). Consider the condition in 4 (A) where the ap-

plied voltage E_p has an instantaneous polarity such that the top terminal "a" of the primary is positive and the bottom "b" negative. E_p will cause a flux-producing (magnetizing) current to flow and the resulting flux will induce a counter e.m.f. (E_c) across the primary, which is equal and opposite to the applied e.m.f. As this c.e.m.f. is opposite to the applied e.m.f. it will tend to oppose the flow of current due to E_p , and a moment's reflection will make it clear that the terminal polarity of the c.e.m.f. must be identical to the terminal polarity of the applied e.m.f.; i.e. the c.e.m.f. terminal polarity has the top primary terminal "a" positive and the bottom "b" negative.

This rather obvious fact is stressed here because the same flux in linking the secondary, will induce a voltage across it in such a direction as to produce a terminal polarity similar to the terminal polarity of the c.e.m.f. across the primary—providing both coils are wound in the same sense—which is the condition in 4 (A). Thus terminal "c" is positive and terminal "d" is negative.

In 4 (B) the applied voltage E_p has the same instantaneous terminal polarity as 4 (A), as does the counter e.m.f. across the primary. Note however, that the secondary coil is wound in opposite sense to the primary, consequently the terminal polarity of the secondary will be opposite to the c.e.m.f. terminal polarity of the primary, making the top terminal "c" of the secondary negative and the bottom "d" positive. The same reasoning applies to 4 (C) and 4 (D). In 4 (C) both coils are wound in the same sense BUT ON DIFFERENT LEGS; and note further that

the alternating flux, in flowing around the magnetic core, flows, say, down through the primary and up through the secondary. Therefore, even though the two coils are wound in the same sense, due to the opposite directions of the same varying flux in the two legs, the terminal polarity of the secondary will be *opposite* to the c.e.m.f. terminal polarity of the primary. Thus in (C) the top "a" of the primary is positive and the top "c" of the secondary is negative—for the particular instant under discussion. In 4 (D) the coils are wound in opposite sense and on opposite legs; hence, it is clear from what has been said that now the tops "a" and "c" of the two coils will have the same instantaneous terminal polarity.

However, in all cases the secondary induced voltage is in such direction that the current it produces in the winding and R_L is in the proper direction to oppose, magnetically, the action of the primary current. In an actual transformer the actual polarity at the terminals depends not only on the direction of the windings as illustrated in Fig. 4, but also on the actual physical arrangement of the terminals on the terminal board. Hence it is necessary in practice to check the polarities of the windings by means of a voltmeter; all that it is desired to show here is that the secondary current always opposes magnetically the primary current.

As a simple example of such a polarity check, suppose there are two 6.3 volt windings on a power transformer, and it is desired to connect them in parallel to permit a greater safe current flow. As shown in Fig. 5, terminals a and b are those for secondary coil S_1 , and c

and d are for secondary coil S_2 .

In order to connect them in parallel, the terminals should be

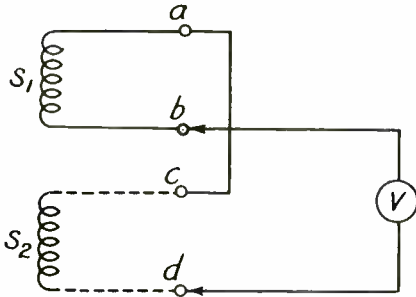

Fig. 5.—Method of connecting two transformer secondaries in parallel.

joined in pairs such that the two terminals of either pair have the same instantaneous polarity. To check this, connect any pair of terminals such as a and c together. Since the circuit is still open at the other two terminals b and d, no danger of a short circuit need be feared. Next connect a Voltmeter between b and d. If a and c have the same instantaneous polarity; i.e. c is plus when a is plus, and c is minus when a is minus, then b and d will have the same instantaneous polarity, and will buck one another. The voltmeter will read zero, and this in turn will indicate that b and d can safely be connected together too, thereby placing S_1 and S_2 in parallel. (The arrangement is exactly similar to two batteries connected in parallel.) If, on the other hand, the voltmeter reads $6.3 + 6.3 = 12.6$ volts, it indicates that S_1 and S_2 are in series adding rather than in series bucking, and hence will be short-circuited if b and d are connected together. The connections must then be reversed: a must be connected to d, and b to c.

VECTOR RELATIONS.—It now remains to discuss the vector relations in a transformer. Suppose the primary is connected to a source of voltage E_p , but the secondary is open-circuited so that no secondary current flows. Then, so far as the primary is concerned, it is as if the secondary coil were not there, and the primary acts like any other inductance coil.

A current I_p flows in it that lags E_p by 90° ; the magnitude of I_p is just sufficient to produce enough flux to induce a c.e.m.f. equal and opposite to the impressed voltage E_p . This is all shown in Fig. 6, where E_p is the vector representing the voltage impressed upon the primary, I_p is the current vector 90° lagging E_p and E_e is the voltage induced in the primary, that lags I_p by 90° and hence lags E_p by 180° . It therefore opposes E_p as shown and the current I_p is of just the proper magnitude to produce E_e just equal and opposite to E_p . (Remember that the circuit is assumed to have no resistance either in the source or in the winding.)

Note that the current I_p is also designated in Fig. 6 as I_m . This is because in a transformer the primary current which flows even in the absence of secondary current is given the special name of **MAGNETIZING CURRENT**; this magnetizing current is assumed to flow at all times whether the secondary is drawing current or not. The flux ϕ_m that I_m sets up is known as the **MAGNETIZING FLUX**. The vector lengths are arbitrary: that for ϕ_m is of a different scale than that for I_m or E_p and the vector cannot be compared in magnitude, but only in phase.

Fig. 6 shows the vector conditions in the primary circuit. How-

ever, just as ϕ_m sets up the c.e.m.f. in the primary, it also induces a voltage E_s in the secondary whose phase is 180° to that of E_p (taking due note of the polarity conditions discussed previously).

The vector relations are shown in Fig. 7. Here E_p , I_m , c.e.m.f. and ϕ_m have the same significance as previously, but E_s has been added to show its phase relative to the other vectors. Note that E_s has

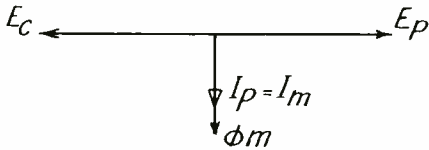

Fig. 6.—Vector relations in the primary of a transformer when the secondary is open-circuited.

been drawn longer than E_p or its equal and opposite E_c ; this merely means that the transformer has been assumed to be of the step-up kind in that the secondary number of turns is greater than that of the primary.

Now suppose that a resistance R_L (as in Fig. 4) is connected across the secondary. Secondary voltage E_s immediately causes a current I_s to flow that is in phase with E_s and of a magnitude given previously by Eq. (4).

$$I_s = E_s / R_L \tag{4}$$

This however, as mentioned previously, causes the primary winding to draw from the source an additional primary current that just balances I_s and prevents the latter from appreciably demagnetizing the core.*

Fig. 8 shows the vector relations that now exist. The vector

*The product of I_s and N_s will equal the product of reflected current and N_p .

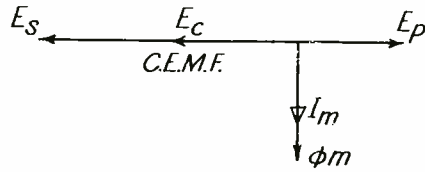

Fig. 7.—Vector relations including that for the secondary voltage when no secondary current flows.

representing the c.e.m.f. in the primary has been omitted merely to simplify the diagram. The secondary voltage E_s causes the current I_s to flow in phase with it, since it has been assumed that the load R_L connected to the secondary was resistive in nature.

However, the flow of secondary current I_s immediately causes a corresponding current I'_s to flow in the primary; the latter, as shown, is 180° out of phase with I_s and is of the proper magnitude to balance its demagnetizing effect in the core. This—it will be shown—will be the case if the step-down relation from I'_s to I_s is the same as the step-up from E_p to E_s ; i.e., on the basis of the turns ratio.

If I'_s just balances the demagnetizing effect of I_s , then I_m , the primary magnetizing current, is left in magnetic control of the core and so the flux in the core is still

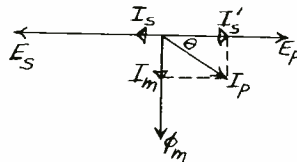

Fig. 8.—Vector relations when secondary current is drawn by a load R_L .

ϕ_m , sufficient to induce a c.e.m.f. in the primary that just balances E_p and also induce in the secondary the

voltage E_s which causes I_s to flow, etc. In short, whether the secondary is permitted to draw current or not, the a-c flux remains ϕ_m , as when the secondary circuit is open.

The actual total or resultant current flowing in the primary is the vector sum of I_m and I'_s , and is denoted by I_p in Fig. 8. Note that I_p lags E_p by an amount θ depending upon the relative magnitudes of I'_s and I_m . In practical power transformer design, I_m is about 5 per cent of I'_s when R_L is such as to draw full load current I_s . Hence, since

$$\theta = \tan^{-1} I_m / I'_s \quad (5)$$

as is evident from Fig. 8, if I_m is very small compared to I'_s , θ will be very small and approximately zero. This means that if a resistor R_L is connected to the secondary and draws sufficient current I_s , the total primary current I_p will be very nearly identical in magnitude and in phase with I'_s , that is, I_p will be practically in phase with E_p . This in turn means that the transformer will appear to the source connected to the primary as a resistor, since it draws a current I_p from the source that is in phase with the latter's applied voltage E_p . This will be discussed in greater detail very shortly.

IRON-CORE TRANSFORMERS

REFLECTED IMPEDANCE.—Returning to I_s and I'_s , note that I'_s is called the PRIMARY EQUIVALENT OF THE SECONDARY CURRENT, and also as the PRIMARY REFLECTED CURRENT, since it is like the reflection of an object in a mirror (due note being taken of the scale): more secondary current

causes more primary reflected current; also whatever the phase of the secondary current I_s is with respect to the secondary voltage E_s , that is the phase of I'_s with respect to E_p . In Fig. 8, I'_s is shown in phase with E_s , then I'_s is in phase with E_p .

The magnitude of I'_s relative to I_s can be derived very simply. I_s flows through the secondary turns N_s (or preferably denote these by N_2) then it develops a m.m.f. of a magnitude $I_s N_s$ ampere turns. The primary thereupon draws the reflected or equivalent current I'_s which, in flowing through the primary turns N_p , develops the m.m.f. $I'_s N_p$.

For equilibrium conditions, the two m.m.f.'s must balance and thus leave the primary magnetizing m.m.f. $I_m N_p$ in control of the core. This means that

$$I'_s N_p = I_s N_s$$

or

$$I'_s = I_s (N_s / N_p) \quad (6)$$

If the transformer is properly designed so that I_m is negligible in comparison with I'_s , I_p will be approximately equal to I'_s , so that Eq. (6) can be re-written as

$$I_p = I_s (N_s / N_p) \quad (7)$$

On the other hand, Eq. (3) indicated that

$$E_s = E_p (N_s / N_p)$$

or

$$E_p = E_s (N_p / N_s) \quad (8)$$

Comparison of Eqs. (7) and (8) indicates that if the transformer is acting as a step-up device for the voltage, it will act as a step-down

device for the current. Thus, if $(N_s/N_p) = 10$, $(N_p/N_s) = 1/10$, so that I_p is ten times I_s , but E_p is one-tenth of E_s , or to put it the other way around, if I_s is one-tenth of I_p , E_s is ten times E_p .

Eqs. (7) and (8) are basic to the transformer, and serve to explain a very peculiar and exceedingly useful property of the transformer, namely that of impedance transformation. This can be demonstrated very simply by the use of the above two equations in conjunction with Ohm's law.

Thus, if a resistor R_L is connected to the secondary, then by Eq. (4), the secondary current is

$$I_s = E_s/R_L \quad (4)$$

This can be substituted in Eq. (7) to yield

$$I_p = \frac{E_s (N_s/N_p)}{R_L} \quad (9)$$

Next, from the first Eq. (8), substitute for E_s in Eq. (9), and obtain

$$\begin{aligned} I_p &= \frac{[E_p (N_s/N_p)] (N_s/N_p)}{R_L} \\ &= \frac{E_p}{R_L} (N_s/N_p)^2 \end{aligned} \quad (10)$$

Now, by simple algebraic transpositions of the appropriate quantities in Eq. (10), there is obtained

$$\frac{E_p}{I_p} = R_L (N_p/N_s)^2 \quad (11)$$

Pause and reflect what the quantity E_p/I_p in Eq. (11) represents. Suppose the transformer and R_L connected to its secondary, were placed in a box, and only the primary terminals were accessible. Now suppose the source is connected through an

ammeter to these terminals, and a current I_p measured when the impressed voltage is E_p .

Suppose further that by suitable means (such as an oscilloscope) it is found that I_p is in phase with E_p . Then so far as can be told from such electrical measurements, the box appears to be a resistor of magnitude $R'_L = E_p/I_p$. This apparent resistance R'_L is due to the fact that an actual resistor R_L has been connected across the secondary, and hence R'_L is called the REFLECTED IMPEDANCE OF THE SECONDARY LOAD IMPEDANCE.

Its magnitude is given by Eq. (11):

$$R'_L = E_p/I_p = R_L (N_p/N_s)^2 \quad (12)$$

which is a fundamental and very important transformer equation. It states that the reflected resistance R'_L is equal to the actual resistance R_L multiplied by the SQUARE of the turns ratio, where the latter is taken as indicated in Eq. (12).

EXAMPLES OF REFLECTED IMPEDANCE.—The practical applications of this fact are enormous in number. It will suffice to cite just a few examples. A vacuum tube power output stage will deliver maximum output into a loudspeaker, for example without exceeding the percentage distortion initially specified, if it feeds its power into a specific value of load resistance; call this R_L . (The method of determining R_L will be taken up in a subsequent assignment.)

On the other hand, the loudspeaker may have a resistance quite different from R_L ; call the loudspeaker's resistance R_{Ls} . It is possible to make R_{Ls} "look like" R_L by interposing a transformer of the proper turns ratio between the amplifier stage and the loudspeaker.

This is illustrated in Fig. 9, where V1 is the output tube, connected as shown to the primary of the output transformer, and the loudspeaker, of resistance R_{LS} , is connected to the secondary of the output transformer. The transformer reflects R_{LS} into a different value R'_L as viewed from the primary side; this value of R'_L is the desired value for the tube to "see" when "looking" into the primary of the output transformer.

It will be well to mention at this point that the reflected resistance R'_L does not necessarily bear some simple relationship to the internal resistance of the tube,—that is, to the plate resistance R_p of the tube. It is often stated in texts that the load resistance R'_L should be twice R_p . This is an approximate relation; the actual relationship is best determined graphically and will be discussed in a subsequent assignment.

However, whatever the value of R'_L should be, R_{LS} can be made to appear to have this value by the proper choice of the turns ratio (N_p/N_s) of the transformer. Thus, referring to Eq. (12), it is to be noted that R_L there refers to R_{LS} here, and R'_L there refers to R'_L here. Also note that it is desired here to solve this equation for the value of the turns ratio. This is

$$(N_p/N_s) = \sqrt{R'_L/R_{LS}} \quad (13)$$

As an example, suppose a 6F6 tube is employed, and it is triode connected. From the tube manual it is found that for 250 volts on the plate and a grid bias of -20 volts, the load resistance it should face is 4,000 ohms. Suppose, however, that the loudspeaker voice coil has

a resistance of 10 ohms. Then from Eq. (13), the output transformer's turn ratio should be

$$(N_p/N_s) = \sqrt{4000/10} = 20$$

This means that the primary winding (facing the tube) should have twenty times as many turns as the secondary winding facing the loudspeaker. (The actual number of turns required in each winding will be discussed further on).

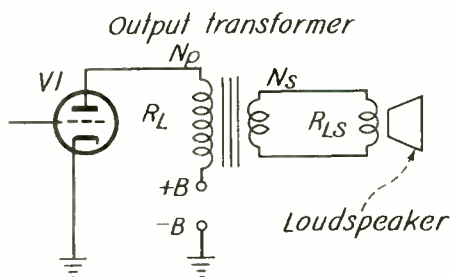

Fig. 9.—Method of matching an output tube to a loudspeaker by means of an output transformer.

The next example is that of a telephone circuit. This is illustrated in Fig. 10. The transmitter or microphone is of the carbon-button type, is battery operated, and has an internal resistance denoted by R_m . The head phone or receiver has an internal resistance denoted by R_r which is often different from R_m . In the case of this device, the power output of the transmitter is small and is at a premium, hence as much of this power as possible is desired to be fed into the head phone.

An analysis indicates that maximum power transfer occurs when the source and load resistances are equal, the so-called matched impedance condition. (Vacuum tube amplifiers fail to obey this law because

of distortion considerations). It is therefore necessary to use a matching transformer T to make R_r appear to the transmitter as the value R_m and hence equal to the internal impedance of the transmitter.

Eq. (13) gives the turns ratio required. Specifically, let $R_m = 200$ ohms, and $R_r = 50$ ohms. Then

$$(N_p/N_s) = \sqrt{200/50} = 2$$

or the primary should have twice as many turns as the secondary. Similar considerations hold for other sources and loads where distortion is not a limiting factor and maximum power transfer is desired.

An interesting point to note is that the transformer matches both ways. Thus, in the above example, the turns ratio was 2, so that $R_r = 50$ ohms looked like $(50)(2)^2 = 200$

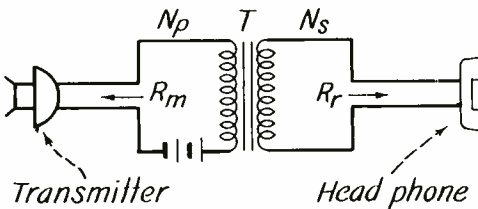

Fig. 10.—Use of a matching transformer T between a transmitter and a receiver in a telephone circuit.

ohms on the primary side. But $R_m = 200$ ohms connected on that side looks like

$$(200)(1/2)^2 = 50 \text{ ohms}$$

to the head phone. Hence if the matching transformer matches 50 ohms to 200 ohms, it also matches the 200 ohms to the 50 ohms.

A third example will illustrate the use of transformers for impedance transformation. Thus, as illustrated in Fig. 11 a ribbon microphone consists of a duralumin corrugated ribbon which is caused to vibrate by the sound waves in a magnetic field and thereby to generate a corresponding audio voltage.

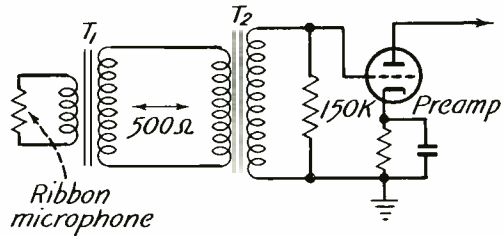

Fig. 11.—Ribbon microphone input circuit.

It is then necessary to transmit this inherently feeble signal to a preamplifier, where it is further amplified and then routed through the necessary equipment for recording, broadcasting, or sound reinforcement as the case may be. The preamplifier is preferably located in a rack and hence at an appreciable distance from the microphone, which is located in the studio.

The ribbon microphone is characterized by a very low internal impedance, on the order of a fraction of an ohm. If it were attempted to transport the signal over ordinary audio wires to the preamplifier, the resistance and particularly the reactance of the wires at the higher audio frequencies would absorb most of the signal and leave very little to be utilized at the preamplifier.

Hence a method of impedance transformation is employed as shown. Transformer T_1 has a turns ratio that steps up the voltage and the

impedance from that of the ribbon to a value of 500 or 600 ohms. This is the usual impedance of audio lines; in this case it means that the impedance looking into the secondary of T_1 , when the ribbon microphone is connected to the primary, is 500 ohms. In short, the fraction of an ohm ribbon impedance is transformed by T_1 into a 500 ohm source as viewed from the secondary side.

Such an impedance permits audio signals to be successfully transported over long distances, even on the order of miles. In the case of studio runs the distances involved are on the order of 100 feet or so. For maximum power output from the microphone, the termination on the other end of the run should be 500 ohms, to match the microphone.

It is clear that the resistance and even the inductive reactance of the audio wires will be negligible compared to the 500 ohm termination, and hence will not absorb any appreciable power. There is also present across the audio line a certain amount of shunt capacitance, but the reactance of this is very high even at the highest audio frequencies, and hence will be a negligibly high shunt compared to the 500-ohm termination. A so-called 500-ohm line therefore represents a line whose impedance is neither too high nor too low compared to the inevitable circuit impedances encountered in the connecting wires.

Observe, however, from Fig. 11 that the 500-ohm line fed from the secondary of T_1 is not terminated in a 500-ohm load resistance, but instead is terminated in transformer T_2 . This is also of the step-up type and has a turns ratio such that if 150,000 ohms, for example, is connected to its secondary as shown, the

impedance looking into the primary will be 500 ohms, and hence just right for terminating T_1 .

The situation is therefore as follows: if 150,000 ohms is connected to the secondary of T_2 , it "looks" like 500 ohms when "viewed" from the primary side of T_2 , and this in turn looks like the fraction of an ohm equal to the internal impedance of the ribbon when viewed from the primary of T_1 . Thus 150,000 ohms has been reflected in two steps to a value equal to the ribbon impedance.

The question may very naturally arise as to why T_1 did not immediately transform from the ribbon impedance to 150,000 ohms and thus eliminate T_2 . The answer is that the intervening audio line would then be a 150,000-ohm line, which is such a high-impedance line that its shunt capacity would act as too great a by-pass at the higher frequencies compared to 150,000 ohms, and therefore attenuate these frequencies unduly.

For that reason the impedance is first stepped up to 500 ohms, the signal transmitted to the preamplifier, and then at the preamplifier stepped up further to 150,000 ohms, since the lead from the secondary of T_2 to the grid of the first preamplifier tube can be made less than an inch long.

A further question that may be raised is as to why the impedance is stepped up further from 500 to 150,000 ohms. The reason is that in stepping up the impedance, the voltage is also stepped up. The vacuum tube is essentially a voltage-operated device, and the more signal voltage applied to the grid, the greater is the output of the preamplifier.

Hence the voltage is stepped up

as high as possible in T_2 , and in the process the impedance is also stepped up from 500 ohms to 150,000 ohms. Some transformers can be designed to step up the impedance to as high as 500,000 ohms (and the signal voltage accordingly) but as a rule, the greater the impedance step-up, the narrower is the range of frequencies that the transformer can uniformly handle.

In actual practice the 150,000 ohm resistor is omitted in a low-level circuit such as that involving a ribbon microphone. The reason is that a better signal-to-noise ratio is obtained, because the noise from the resistor is eliminated.

In this case the impedances involved in the circuit are the inductive reactances of the two transformers due to their magnetizing currents. These reactances are usually so high as to constitute negligible shunts compared to the resistance values mentioned, but of course constitute the sole impedance when the 150,000 ohm resistor is eliminated.

Thus the line is terminated in a high inductive reactance. The shunt capacitance of the line will therefore act—particularly at the higher audio frequencies—as a low parallel impedance to the above inductive reactance and hence will tend to prevent the higher audio frequencies from reaching the transformers. This is the case if the source impedance is high so that it is incapable of furnishing the large currents drawn by a low impedance.

However, the source is the ribbon microphone of low resistance. It is therefore capable of furnishing all the current the line capacitance requires at the higher audio frequencies, as well as the current drawn by the transformers. Hence.

BECAUSE THE SOURCE RESISTANCE IS LOW, the frequency response remains "flat" even if the transformer secondary load resistance is removed, and at the same time—as mentioned previously—such omission produces a higher signal-to-noise ratio.

IDEAL AND ACTUAL TRANSFORMERS:—
The action of the magnetizing current can be explained in terms of a theoretical ideal transformer in conjunction with other circuit elements. An ideal transformer is one a). having no losses, b). no shunt winding capacitances, c). all the flux of any one winding links all the other windings, and d). the inductance of the primary and of the secondary windings is infinite, so that but an infinitesimal magnetizing current is drawn.

An infinite inductance can be obtained (theoretically) by employing a core of infinite permeability and a finite number of turns, or by employing an infinite number of turns in each winding. The winding can nevertheless have the desired turns ratio; a 3:1 ratio, for example, means that the secondary turns are three times the infinite number of turns of the primary, and hence infinite, too.

Such a transformer draws but an infinitesimal magnetizing current, but when a finite current is drawn from the secondary, a corresponding equivalent current is drawn by the primary. The vector diagram of Fig. 8, reduces to that shown here in Fig. 12; it will be observed that I_m is essentially zero, so that $I_p = I'_s$. A resistance connected across the secondary appears as an exactly equivalent resistance connected across the primary, and if no secondary current is drawn, the primary current is essentially zero too, so

that looking into the primary one sees an open circuit or infinite impedance. Such action on the part of the transformer is clearly ideal in that the transformer does not intrude with any of its characteristics except the desired ones of transforming the voltages, load currents and hence impedances.

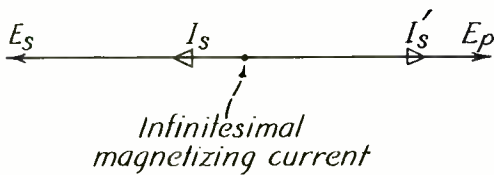

Fig. 12.—Vector diagram for an ideal transformer having a resistor connected across the secondary.

An actual transformer, as has been pointed out, does make its presence known by such factors as losses magnetizing currents, and the like, in addition to the impedance transforming characteristic. It is possible to represent an actual transformer by the proper circuit combination of inductances, resistors, and an ideal transformer, in the manner shown in Fig. 13.

Here $R_{p.w}$ and $R_{s.w}$ represent respectively the primary and secondary winding resistances. These are series elements as shown, and reduce the applied voltage by virtue of the IR drops produced in them.

The inductances L_{Lp} and L_{Ls} represent respectively the primary and secondary leakage inductances. In an actual transformer, not all of the flux set up by one winding links all the turns of the other winding. As illustrated in Fig. 14, if the two windings are wound on opposite legs of the core some of the flux (solid line) pro-

duced by the magnetizing current of the primary links both windings and is designated by the name MUTUAL flux; and some of the flux (dotted line) is leakage across the core "window" and links the one winding but not the other.

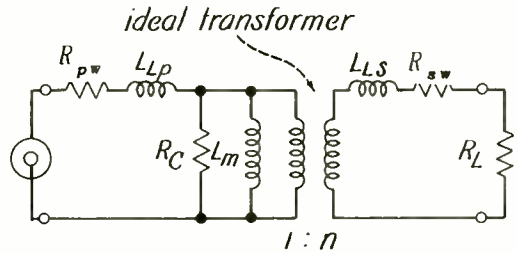

Fig. 13.—Representation of an actual transformer by resistors, inductances, and ideal transformer. n is the ratio of secondary to primary.

In the figure, not only does magnetizing current I_m flow in the primary, but reflected current I'_s , owing to the current I_s drawn from the secondary by R_L . It will be recalled that I'_s opposes the demagnetizing effect of I_s . This is true as regards the setting up or opposing of flux around the core. With regard to flux across the core window, the two load currents I_s and I'_s act in parallel and produce leakage flux, part of which links the primary and part the secondary as shown.

The presence of such leakage flux gives the windings a certain amount of inductance, called leakage inductance. It is as if actual inductance was inserted in series with the primary and with secondary as shown. In many transformers this effect is minimized as much as possible by breaking up the windings into sections, and interleaving them so as to make it difficult for the flux of one winding to a-

void passing through the other winding.

On the other hand, in transformers used to feed neon tubes this effect is purposely accentuated, because once the arc is struck in the neon gas, its resistance drops to a very low value. The inductances L_{Lp} and L_{Ls} prevent excessive current flowing under such short-circuit conditions. Reference to Fig. 13 shows that if R_L drops to a very low value, the only limitations to the current flow are R_{pw} , and R_{sw} . Ordinarily, in a well-designed transformer R_{pw} and R_{sw} are purposely made low to keep down the losses and also the heating in the transformer, so that L_{Lp} and L_{Ls} must be made high to limit the current flow. Such action is by inductive voltage drop, which does not produce wattage losses.

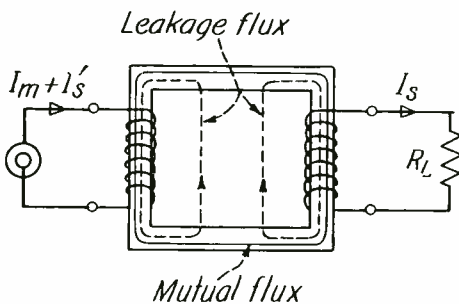

Fig. 14.—Showing how flux can be resolved into mutual and leakage components.

Refer next to R_c in Fig. 13. This represents the core losses in the transformer; these consist of hysteresis and eddy current losses in the iron core, and have been treated in a previous assignment on magnetic circuits.

Next, L_m represents an inductance that accounts for the magnetizing current flow. If all the flux

of the one winding linked that of the other, so that L_{Lp} and L_{Ls} were zero, then inductance L_m would remain and show how a primary current flows even if the secondary is open circuited. Its value is very nearly equal to the self inductance of the primary in the case of an iron-core transformer.

So far these circuit elements account for various characteristics of the transformer except one, and that is its transforming ability. THIS CAN BE REPRESENTED ONLY BY THE IDEAL TRANSFORMER; NO OTHER CIRCUIT ELEMENT CAN REPRESENT THIS ACTION. It therefore has to be included in Fig. 13 to make the circuit equivalent to an actual transformer. In addition, capacitors across the primary and secondary terminals are added in the case of input and inter-stage audio transformers to take care of the winding capacitances, since these have a profound effect upon the high-frequency response of the units. The action will be discussed at the appropriate place in the course.

BEHAVIOR OF ACTUAL TRANSFORMER:—The action of an actual transformer can now be better understood. As illustrated in Fig. 15 (A), the actual transformer has a load resistor R_L connected across the secondary. The impedance Z seen looking into the primary will be a combination of the reflected value of R_L , which is R_L/n^2 (where n is the ratio as indicated) and the transformer impedances.

Ordinarily, the winding resistances are small, and the core loss resistance R_c is very high, so that both will be neglected here for simplicity. At low frequencies the series leakage reactances ωL_{Lp} and ωL_{Ls} are small because ω is low

so that they can be neglected. However the reactance ωL_m owing to the mutual inductance cannot be so ignored, since it appears in parallel with the reflected resistance R_L/n^2 .

This is shown in (B). At low frequencies an actual transformer therefore adds a shunt inductance L_m to the resistance it reflects to the terminals at which the impedance measurements are being made. At very low frequencies the input impedance Z is predominantly inductive and low in magnitude; the transformer has very markedly intruded some of its characteristics in conjunction with reflecting the load resistance.

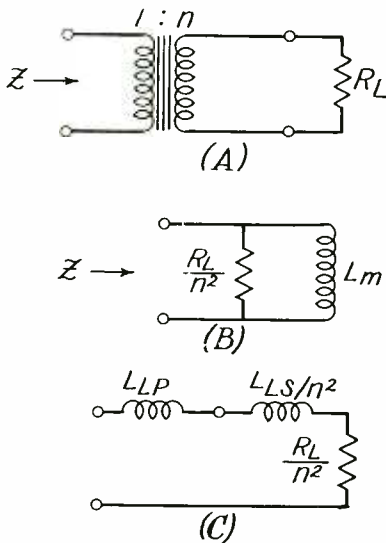

Fig. 15.—Action of an actual transformer in reflecting a load impedance at low and at high frequencies.

At higher audio frequencies, usually in the neighborhood of 1,000 (c.p.s.), the reactance ωL_m becomes so high that it constitutes a negligible shunt across the resistances and hence the impedance Z becomes

essentially R_L/n^2 . In short, in this frequency range the transformer approaches the ideal transformer in behavior.

At the highest audio frequencies the series reactances ωL_p and ωL_s can no longer be ignored. As indicated in (C), the impedance Z becomes now R_L/n^2 in series with L_p and the REFLECTED VALUE of the secondary leakage inductance, which is L_s divided by n^2 , or L_s/n^2 , as indicated. In a good audio transformer the impedance Z does not vary very markedly from the value R_L/n^2 over a wide frequency range; this means that L_m is made as large as possible by using a sufficient number of turns and a large cross section of high permeability material for the core, whereas L_p and L_s are made as small as possible.

Thus, the reactance of L_m at the lowest audio frequency is made two to three times the value of R_L/n^2 , where R_L represents the secondary impedance that the transformer is normally designed to work into. For example, suppose the secondary is designed to operate into a 150,000-ohm load, and that the turns ratio is 17.32 to one.

Then the reflected impedance looking into the primary is

$$R_L/n^2 = 150,000/(17.32)^2 = 500 \text{ ohms}$$

Suppose the lowest audio frequency of interest is 30 c.p.s. Then $\omega L_m = 2\pi 30 L_m$ should be say, three times 500 ohms = 1,500 ohms. Thus

$$2\pi 30 L_m = 1500$$

or

$$L_m = 1500/(2\pi 30) = 7.95 \text{ henries}$$

If the leakage reactance is kept down to a low value, then essentially this value of inductance is measured for the primary winding when the secondary winding is left open-circuited; i. e., L_m is essentially the self inductance of the winding.

MULTI-WINDING TRANSFORMERS.—When a transformer has more than one secondary, and impedances are connected to them, they reflect these impedances to the primary side so that the reflected impedances appear in parallel. This is illustrated in Fig. 16, where a four-winding transformer is shown in (A), with loads R_{L1} , R_{L2} , and R_{L3} connected to the secondaries. The symbols n_1 , n_2 , and n_3 refer to the respective ratios of the secondary turns relative to the primary winding. These cause the various resistances to be reflected to the primary in parallel as shown in (B). Thus R_{L1} appears as R_{L1}/n_1^2 across the primary terminals; R_{L2} appears as R_{L2}/n_2^2 across the primary terminals, and hence in parallel with R_{L1}/n_1^2 and finally R_{L3} appears as R_{L3}/n_3^2 across the primary terminals.

One practical example of this is the power transformer shown in Fig. 3 on page 4. The plate currents drawn by the various amplifier stages through the rectifier tube act as a load resistance connected across secondary S_1 ; the heater currents drawn from S_2 , and the filament S_4 , all represent load resistors across these secondaries, and their reflected values all appear in parallel across the primary.

Another example is that of an audio output transformer that feeds a number of loudspeakers installed in different rooms, for example, in a public address system. This is illustrated in Fig. 17, where a push-

pull output stage is shown, composed of the push-pull audio input transformer T_1 feeding signal to the grids of the two tubes $V1$ and $V2$, and out-

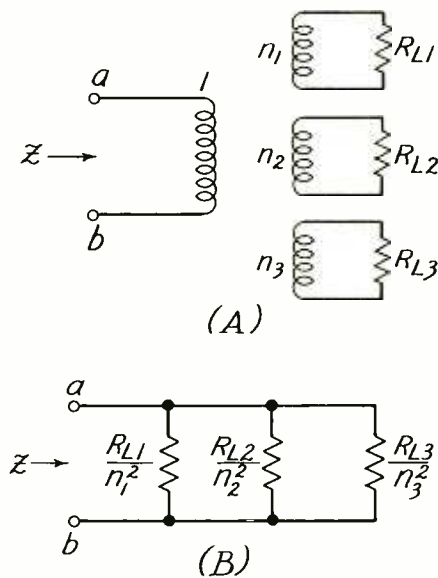

Fig. 16.—Four-winding loaded transformer and equivalent circuit.

put transformer $T2$, having a center-tapped primary, as shown, and having four secondaries, $S1$, $S2$, $S3$, and $S4$ feeding loudspeakers L.S. #1, L.S. #2, L.S. #3, and L.S. #4. (The latter can represent banks of loudspeakers instead of individual units).

Each loudspeaker or loudspeaker bank reflects as an equivalent impedance across the primary winding, and the combination of loads appear in parallel across the primary. By a suitable choice of turns ratios it is possible to cause the total reflected impedance to be the correct value to obtain the required power output from the tubes, and at the same time to cause the power output to divide between the various loud-

speakers in any ratio desired. Thus L.S. #1 might be a ball-room loud-speaker, and require most of the power, whereas the others might be installed in small rooms and hence require but a small amount of power each.

As a numerical example, suppose in Fig. 17 that the turns ratio of the primary to S1 is 20:1 and L.S. #1 is 5 ohms; the turns ratio to S2 is 15:1 and L.S. #2 is 10 ohms; the turns ratio to S3 is 10:1 and L.S. #3 is 50 ohms; and finally the turns ratio to S4 is 30:1 and L.S. #4 is 15 ohms. Assume further that the primary voltage is 180 volts. The results can be summarized as follows:

AUTO TRANSFORMERS.—A special form of transformer in which a winding is common to both the primary and the secondary coils, is known as an auto-transformer. It is illustrated in Fig. 18, where it will be observed that the lower windings constitute the primary coil and also part of the secondary coil. The action is however no different from a transformer having separate primary and secondary coils, except that the current in the common winding is the difference between the primary and secondary load currents I_p and I_s , and hence is less than either. This permits a smaller size copper wire to be used in the common wind-

SECONDARY COIL	VOLTAGE ACROSS SECONDARY	REFLECTED IMPEDANCE TO PRIMARY OHMS	POWER CONSUMPTION E^2/R WATTS
S1	$\frac{180}{20} = 9 \text{ V.}$	$5 / \left(\frac{1}{20}\right)^2 = 2000$	$(9)^2/5 = 16.2$
S2	$\frac{180}{15} = 12 \text{ V.}$	$10 / \left(\frac{1}{15}\right)^2 = 2250$	$(12)^2/10 = 14.4$
S3	$\frac{180}{10} = 18 \text{ V.}$	$(50) / \left(\frac{1}{10}\right)^2 = 5000$	$(18)^2/50 = 6.48$
S4	$\frac{180}{30} = 6 \text{ V.}$	$(15) / \left(\frac{1}{30}\right)^2 = 13,500$	$(6)^2/15 = 2.4$
			TOTAL 39.48 Watts

$$n = N_s/N_p$$

The total power is 39.5 watts, divided between the secondaries in the manner indicated above. The total resistance reflected across the primary winding is

$$1/\left(\frac{1}{2000} + \frac{1}{2250} + \frac{1}{5000} + \frac{1}{13500}\right)$$

$$= 1/ (.0005 + .000444 + .0002$$

$$+ .000074) = 1/ (.001218) = 820 \text{ ohms.}$$

ing, and also in general means less copper I^2R losses, and therefore more efficient operation.

If N_p is the total number of turns of the primary, and N_s that of the secondary, then the voltage step-up is in the ratio of N_s/N_p and the impedance step-up is the ratio of $(N_s/N_p)^2$ even though part of N_s and N_p are common. Auto-transformers are used in radio to some extent, and

one example is an audio transformer shown in Fig. 19. Here the output stage feeds an output transformer having say, a 500-ohm secondary.

to tap the secondary of the output transformer and cause this winding to function as a sort of auto transformer.

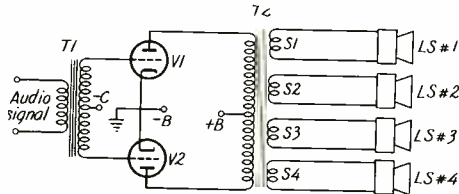

Fig. 17.—Audio output transformer feeding a plurality of loudspeakers.

This means that if 500 ohms is connected to the secondary, it will reflect back to the tube the proper load resistance required by that tube for optimum power output.

Instead of connecting a 500-ohm load, however, an auto-transformer is connected as shown. Various loads can be connected to different taps of the autotransformer, either individually or in groups, so as in any case to reflect a total of 500 ohms to the secondary of the output transformer.

Thus the autotransformer here acts to furnish various output impedances or taps to accommodate

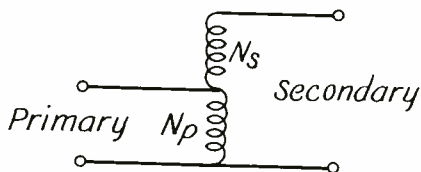

Fig. 18.—Schematic diagram of an auto transformer.

various individual or groups of loud speakers. A common alternative is

AIR-CORE TRANSFORMERS

The preceding discussion dealt essentially with iron-core transformers having little leakage flux between the windings or, in other words, tight coupling, a term that will be explained more fully farther on. Such transformers are used at low frequencies, because the iron helps to obtain high inductance and hence high inductive reactance in spite of the low frequencies involved, and without requiring a prohibitive number of turns. A high

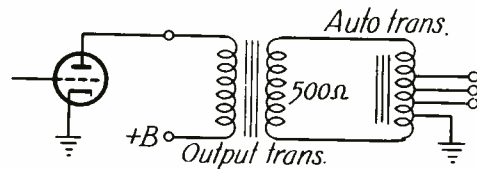

Fig. 19.—Example of an autotransformer used in an audio output stage.

inductive reactance in turn serves to keep the magnetizing current at an acceptably low value relative to the reflected primary load current, so that the unit approaches the ideal transformer in its characteristic. A further characteristic is that the transformer is broad-band, i.e.; it can handle simultaneously a wide range of frequencies with equal facility.*

*The ordinary iron-core audio transformer can step up voltages, reflect impedances, etc., over a range of frequencies from 30 c.p.s. or less to 20,000 c.p.s. or higher. Indeed, video transformers have been built that can handle a range from 20 c.p.s. to over 5,000,000 c.p.s.!

At the higher i.-f. and r.-f. portions of the spectrum, iron cores tend to have rather high losses, except in the pressed powdered form, and moreover, the inductance of the windings can be lower since the frequency is higher, so that the reactance ωL can be made high even if L is low.

As a result, the coils are generally wound on hollow dielectric forms or tubes; the core is essentially air or its equivalent in magnetic permeability, and the devices are known as air-core transformers. These will now be discussed.

FUNDAMENTAL CONSIDERATIONS.—The theory given previously for the iron-core transformers applies to air-core transformers too, but a different approach is preferable because the mutual inductance L_m is much lower, (see Fig. 13) and the leakage inductances are relatively much larger; indeed, the latter are usually many times L_m in magnitude.

The method of approach is as follows: In the case of an ordinary self-inductance, the fundamental definition is that the inductance L multiplied by the rate of change of current with time equals the voltage induced. In the special case where the current varies in a sinusoidal manner at a frequency f , the induced voltage is

$$E = 2\pi fLI \tag{14}$$

where E is in volts; I is in amperes, f in cycles/sec.; and L in henries.

In a similar manner, the mutual inductance M can be defined. Thus, if the current I in one coil varies in a sinusoidal manner at a frequency f , the voltage induced in another coil is such that

$$E = 2\pi fMI \tag{15}$$

where M is also measured in henries. Thus, just as self-inductance L determines the amount of voltage a varying current I will induce in the coil in which it is flowing, just so does mutual inductance M determine the amount of voltage the varying current will induce in a neighboring coil.

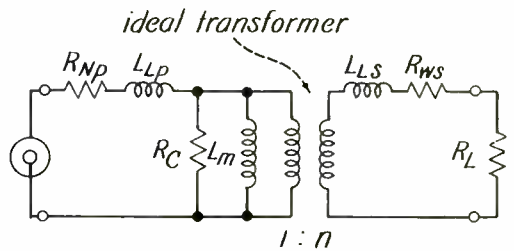

Fig. 13.—Representation of an actual transformer by resistors, inductances, and ideal transformer.

It can be shown that the mutual inductance between two coils is the SAME regardless of in which coil the current is flowing. Thus, as illustrated in Fig. 20, if a current I is caused to flow in coil A, and the mutual inductance is M , so that a voltage E is thereby induced in coil B, then if the SAME current I is caused to flow in coil B, the SAME voltage E will be induced in coil A.

COMPARISON OF AIR AND IRON-CORE TRANSFORMERS.—In the case of the iron-core transformer, the secondary voltage was equal to the primary voltage multiplied by the turns ratio. This was because practically all the flux of the one coil linked the other coil. In the case of the air-core coil, where but a fraction of the flux links the other coil,

the secondary voltage is but a fraction of the primary voltage multiplied by the turns ratio, so that the latter rule for calculating the secondary voltage will be considerably in error. As a result, it is preferable to compute the primary current, and multiply it by $2\pi f M$ in order to solve for the secondary voltage.

Another difference between the two types of transformers is that in the case of an iron-core transformer the magnetizing current I_m is very small, and can usually be neglected in comparison with the primary equivalent of the secondary load current. Thus a resistance connected to the secondary draws a nearly in-phase current from the generator connected to the primary.

In the case of an air-core transformer, the magnetizing current may be so large as to mask the primary equivalent of the secondary load current. Furthermore, the leakage inductance may be so high (see Fig. 21) that the load current will be kept down to a low value.

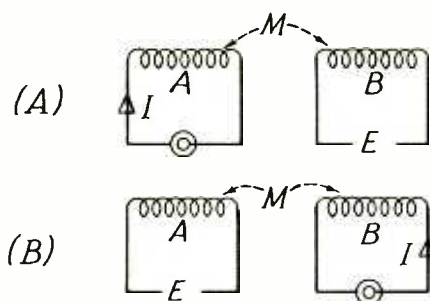

Fig. 20.—The mutual inductance is the same regardless of in which coil the current is flowing.

Thus L_{Lp} will tend to limit the primary equivalent current I'_s ; and L_{Ls} , the secondary load current I_s . At the same time, if the coils have

relatively few turns, their inductance will be small, so that the inductance L_m in Fig. 21 will be small, and the magnetizing current I_m will be large,—often many times I'_s in value even when the secondary is short-circuited ($R_L = 0$).

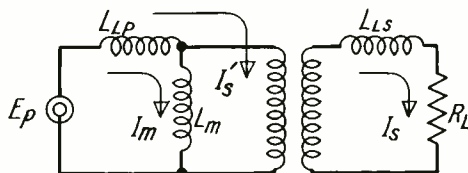

Fig. 21.—If the leakage reactance is high, the load current will be small.

ANALYSIS OF AIR-CORE TRANSFORMER BEHAVIOR.—These differences between the two types of transformers make it desirable to handle the air-core transformer in a different manner from the iron-core type. The method is as follows:

Let L_p be the self inductance of the primary. It can be measured on a Wheatstone Bridge or other suitable measuring device while the secondary is left open-circuited. Similarly, let L_s be the self inductance of the secondary, measured while the primary is open circuited. Finally let M be the mutual inductance.

This is most readily measured as follows: Connect the two coils in series in one polarity, and measure the overall inductance. This will either exceed or be less than the sum of $L_p + L_s$. The discrepancy is due to the action of M . If the coils are connected together so that they aid each other in setting up flux, then the total inductance will be increased over the simple

sum ($L_p + L_s$) by an amount $2M$; that is, the reading on the Wheatstone Bridge or other measuring device will be

$$L_1 = L_p + L_s + 2M \quad (16)$$

from which, solving for M , there is obtained

$$M = \frac{L_1 - (L_p + L_s)}{2} \quad (16a)$$

If the coils oppose each other's efforts to set up flux, then the inductance will be less than ($L_p + L_s$) by the amount $2M$; i.e., the reading obtained will be

$$L_2 = (L_p + L_s) - 2M \quad (17)$$

from which M may also be solved to obtain

$$M = \frac{(L_p + L_s) - L_2}{2} \quad (17a)$$

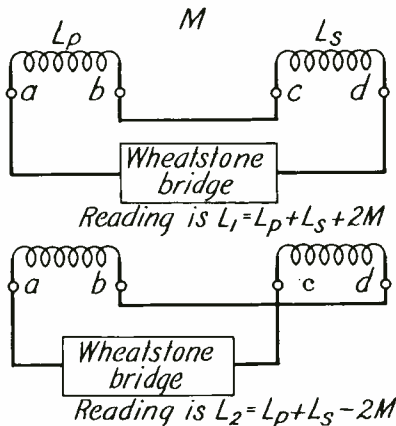

Fig. 22.—Method of measuring the mutual inductance between the two coils.

Refer to Fig. 22 for the connections.

The value for M may also be obtained from the two bridge readings, without measuring L_p or L_s . Thus,

solving Eqs. (16) and (17) simultaneously, there is obtained

$$M = (L_1 - L_2)/4 \quad (18)$$

As an example, suppose the first reading is $L_1 = 100 \mu\text{henries}$ and the second reading is $L_2 = 60 \mu\text{henries}$. Then, by Eq. (18),

$$M = (100-60)/4 = 10 \mu\text{henries}$$

mutual inductance.

The value of M can vary from zero up to a certain maximum value. The zero value occurs if the two coils are so widely separated in space that practically no flux of one links the other. The maximum value of M occurs when all the flux of one links the other coil. This condition is approached if the two coils are very close together; for example, if the turns of one coil are immediately adjacent to those of the other coil, or if they are both wound over an iron core which concentrates the flux and thus causes it to pass through both coils.

The maximum value of M is very simply expressed in terms of the self-inductances L_p and L_s of the coils:

$$M = \sqrt{L_p L_s} \quad (19)$$

The two coils are said to be (magnetically) coupled 100 per cent, or the COEFFICIENT OF COUPLING, denoted by the symbol k , is unity.

On the other hand, not all the flux of one may link the other coil. In this case k is less than unity. For example, if only half of the flux of one coil links the other coil the coupling is $k = 0.5$. In this case M is half of $\sqrt{L_p L_s}$, and in general

$$M = k\sqrt{L_p L_s} \quad (20)$$

In i.f. and r-f. coils, the coefficient of coupling k is in the range from 0.005, or but a fraction of that employed in iron-core transformers, where it has a value on the order of 0.98. This means that the mutual inductance is relatively small and the leakage inductances are very high for an air-core coil; in short, it departs very markedly from an ideal transformer.

SERIES REFLECTED IMPEDANCE.—As a result, the reflected secondary impedance is but a small portion of the impedance it presents to a generator; the leakage reactances tend to predominate. Hence, if an impedance Z is connected across the secondary, it is of little use to reflect it as an equivalent impedance across the primary of value Z_L/n^2 , where n is the turns ratio, because the leakage reactances have to be added in, as well as the effect of the relatively large magnetizing current flow.

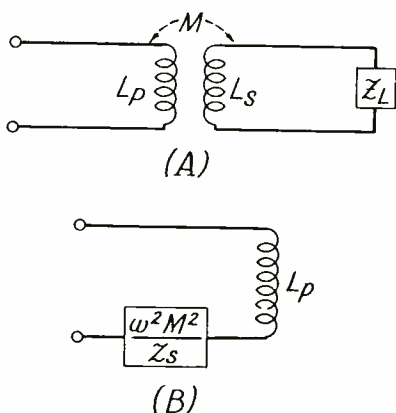

Fig. 23.—An air-core transformer with a secondary load, and the equivalent series representation of the circuit.

The procedure is therefore to reflect the secondary impedance as an equivalent impedance IN SERIES WITH the primary. This is illustrated in Fig. 23. In (A) is shown an air-core transformer having a primary self-inductance L_p ; a secondary self-inductance L_s , a mutual inductance M , and a secondary load Z_L . The latter may be a resistance, for example, or a capacitor, or any other circuit element or combination of elements.

In (B) is shown a circuit which presents the same impedance when measured at the primary terminals as does the actual circuit of (A). Here the secondary circuit, including the load Z_L , is shown as an impedance in series with the primary.

Its magnitude is given by the expression:

$$\frac{\omega^2 M^2}{Z_s}$$

where Z_s represents the secondary inductive reactance ωL_s in series with the load impedance Z_L . Specifically, if Z_L is a resistor R_L , then $Z_s = R_L + \omega L_s$, where the dots indicate vector addition, in that the vector representing ωL_s is at right angles to the vector representing R_L .

The total impedance looking into the primary is

$$Z_p = \omega L_p + \frac{\omega^2 M^2}{Z_s} \quad (21)$$

As an example of the use of Eq. (21), consider the typical r-f amplifier stage shown in Fig. 24. Here the resistance R_s of the secondary coil is taken into account and the secondary load is the variable capacitor C_s . In a following assign-

ment it will be shown that this has a reactance $-1/\omega C_s$, and is the negative of an inductive reactance. As such it can cancel an inductive reactance (such as ωL_s) and thereby produce the phenomenon of RESONANCE. The procedure of adjusting the capacity C_s until resonance occurs is known as TUNING.

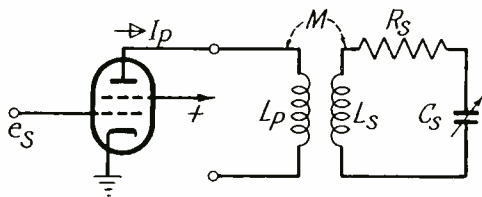

Fig. 24.—Typical r-f amplifier stage.

First calculate the impedance of the secondary circuit. This is

$$Z_s = \omega \dot{L}_s + \dot{R}_s - 1/\omega \dot{C}_s \tag{22}$$

where, as before, the dots indicate vector addition. Note, however, that ωL_s and $1/\omega C_s$ are added algebraically, and the result is then added vectorially to R_s .

According to Eq. (21), the impedance Z_s reflects into the primary to produce a total impedance

$$Z_p = \omega \dot{L}_p + \frac{\omega^2 \dot{M}^2}{\omega \dot{L}_s + \dot{R}_s - 1/\omega \dot{C}_s} \tag{23}$$

Now if the secondary circuit is tuned to resonance, $-1/\omega C_s$ will just cancel ωL_s ; i.e.,

$$\omega \dot{L}_s - 1/\omega \dot{C}_s = 0$$

so that Eq. (23) reduces to

$$Z_p = \omega \dot{L}_p + \frac{\omega^2 \dot{M}^2}{\dot{R}_s} \tag{24}$$

the quantity $\omega^2 M^2/R_s$ represents a resistance whose magnitude varies INVERSELY as R_s ; i.e., the smaller R_s is, the larger is $\omega^2 M^2/R_s$. This is in series with the primary inductance L_p , as is indicated in Fig. 25.

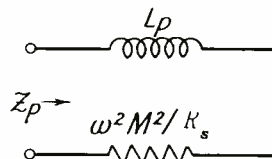

Fig. 25.—Equivalent circuit representing the primary impedance.

Ordinarily the reactance ωL_p is fairly low compared to $\omega^2 M^2/R_s$, so that the impedance Z_p is essentially $\omega^2 M^2/R_s$, and the larger this quantity is, the greater will be the output voltage of the vacuum tube feeding it, since the gain of a vacuum tube increases as its load impedance increases.

ILLUSTRATIVE EXAMPLE.—As an example of the magnitude involved, suppose $L_p = 100 \mu\text{henries}$; * $M = 20 \mu\text{henries}$; $R_s = 8 \text{ ohms}$, and frequency $f = 1.5 \text{ mc}$. Then

$$\begin{aligned} \omega L_p &= 2\pi \times 1.5 \times 10^6 \times 100 \times 10^{-6} \\ &= 942 \text{ ohms.} \end{aligned}$$

and

$$\begin{aligned} \omega^2 M^2/R_s &= (2\pi \times 1.5 \times 10^6 \times 20 \\ &\times 10^{-6})^2/8 = 4,438 \text{ ohms.} \end{aligned}$$

The total impedance Z_p has a magnitude (refer to Fig. 26)

$$\begin{aligned} Z_p &= \sqrt{(942)^2 + (4,438)^2} \\ &= 4,528 \text{ ohms} \end{aligned}$$

*The degree of coupling is greater than that which is often used.

This, it will be noted, is but slightly greater than the series reflected secondary impedance of 4,438 ohms, and hence substantiates the statement made above that ωL_p is generally negligible compared to $\omega^2 M^2 / R_s$.

The actual calculation of the gain of an r-f amplifier will be discussed after vacuum tubes have been studied. However, assume here, that a pentode vacuum tube has been connected to the transformer and that it forces a current I_p through the primary of the transformer as shown in Fig. 24. This current induces a voltage in the secondary circuit; by Eq. (15) this has a magnitude

$$E_s = 2\pi f M I_p \quad (25)$$

Suppose $I_p = 0.25$ ma. Then the voltage induced in the secondary coil is

$$E_s = (2\pi \times 1.5 \times 10^6 \times 20 \times 10^{-6} \times 25 \times 10^{-5}) = .047 \text{ volt or } 47 \text{ millivolts.}$$

$$Z = \sqrt{(4,438)^2 + (942)^2}$$

$$Z = 4,528$$

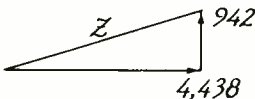

Fig. 26.—Vecto. combination of 4,438 ohms resistive and 942 ohms inductive reactance.

The actual voltage across C_s will be much higher, as will be shown in a subsequent assignment. Indeed, it will be found that the voltage across C_s is Q times E_s , where Q is that of the secondary coil including any primary loading.

Suppose $Q = 50$. Then the voltage across C_s (which is the voltage delivered to the grid of the following vacuum tube), will be $.047 \times 50 = 2.35$ volts.

With reference to Eq. (21), the term $\omega^2 M^2 / Z_s$ gives the effect of the secondary impedance Z_s upon the apparent primary load impedance. On the other hand, an impedance across the primary circuit appears as an equivalent impedance in series with the secondary. The formula is practically identical with that of Eq. (21); the subscripts need merely be interchanged. Thus

$$Z_s = \omega L_s + \frac{\omega^2 M^2}{Z_p} \quad (26)$$

where Z_s represents the total impedance looking into the secondary terminals, and Z_p is the impedance of the primary circuit. This may include the primary self-inductance L_p and the primary winding resistance but particularly—in practical cases—the generator or source impedance (usually resistive).

Thus, referring to Fig. 27 (A), the source is shown as generating a voltage E_g , and as having an internal resistance R_g .

The primary impedance, including the generator, is

$$Z_p = (R_g + R_{pw}) + \omega L_p$$

This reflects into the secondary an impedance

$$\frac{\omega^2 M^2}{(R_g + R_{pw}) + \omega L_p} \quad (27)$$

which is in series with the impedance of the secondary circuit, as shown in (B). This in turn is

$$R_{s_w} + \dot{\omega}L_s$$

where R_{s_w} represents the winding resistance of the secondary coil.

Hence the total impedance seen when looking into the secondary terminals is

$$Z_s = R_{s_w} + \dot{\omega}L_s + \frac{\omega^2 M^2}{(R_c + R_{p_w}) + \dot{\omega}L_p}$$

As a specific example, suppose R_c represents the plate resistance of a vacuum tube acting as a source and that its value is 20,000 ohms. Ordinarily R_{p_w} , the primary winding resistance, is about 15 ohms and hence negligible compared to R_c .

For the values of ω , L_p , M , etc.

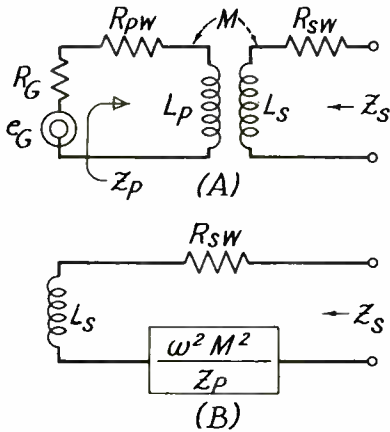

Fig. 27.—R-F transformer and the impedance presented at the secondary terminals.

employed previously, and for a secondary self-inductance of 88 μ henries.

$$\begin{aligned} Z_s &= 8 + 2\pi \times 1.5 \times 10^6 \times 88 \times 10^{-6} + \\ &\quad \frac{(2\pi \times 1.5 \times 10^6 \times 20 \times 10^{-6})^2}{(20,000) + (2\pi \times 1.5 \times 10^6 \times 100 \times 10^{-6})} \\ &= 8 + 828 + \frac{3600\pi^2}{20,000 \quad 942} \end{aligned}$$

The denominator of the third term involves the vector sum of 20,000 ohms resistive and 942 ohms inductive reactance. As is evident from Fig. 28, the total primary impedance is

$$Z_p = \sqrt{(20,000)^2 + (942)^2}$$

= 20,022 ohms, or practically the same as the generator resistance R_c = 20,000 ohms. For simplicity, assume Z_p = 20,000 ohms resistive. Then the impedance reflected in series with the secondary is

$$\frac{3600\pi^2}{20,000} = 1.775 \text{ ohms.}$$

This is a resistance in series with the 8 ohms winding resistance of the secondary, and increases it to 9.775 or 9.78 ohms. Since the inductive reactance at 1.5 mc. is 828 ohms, the Q of this coil is

$$Q = \frac{\omega L}{R} = \frac{828}{9.78} = 84.6$$

Had there been no primary resistance of 1.775 ohms reflected to the secondary, the Q would have been

$$\frac{828}{8} = 103.5$$

Hence the presence of primary resistance—that of the generator—lowers the Q of the secondary coil. However, note from Eqs. (24), and (26) that the impedance in one side of the circuit reflects as a RECIPROCAL value in the other circuit;

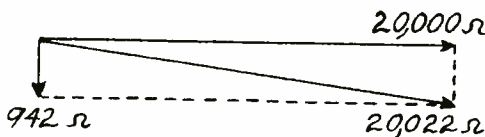

Fig. 28.—Vector combination of resistance and inductive reactance.

the primary resistance R_p of 20,000 ohms appears in the DENOMINATOR OF the expression $(\omega M)^2/R_p$, SO THAT THE LARGER THE ACTUAL RESISTANCE IS, THE SMALLER IS ITS REFLECTED SERIES VALUE.

This means that if the source resistance had been higher than 20,000 ohms, it would have produced LESS damping in the secondary circuit. For example, had the source resistance been 1,000,000 ohms (1 megohm) the reflected value would have been reduced by a factor of $20000/1,000,000 = .02$; the reflected resistance of 1.775 ohms would have been reduced to 0.0355 ohms, and this would have had a negligible af-

fect on the Q of the secondary circuit.

The value 20,000 ohms corresponds to the average plate resistance of a triode tube; the value 1,000,000 ohms is that of the average pentode tube. Hence one can expect a higher secondary Q if a pentode tube is used as the source driving the r-f transformer than if a triode is employed and, as has been indicated, a higher secondary-circuit Q results in a higher gain for the amplifier stage. This is one reason why pentode tubes have supplanted triode tubes in r-f amplifiers, at least for the standard broadcast band.

RESUME'

This concludes the assignment on inductive coupling. The action is best described in terms of transformers having high coupling coefficients, such as iron-core transformers, and transformers having low coupling coefficients, such as air-core transformers.

Iron-core transformers approach the ideal transformer in that they add little of their effects to the circuit except that of transforming an impedance connected to one winding into a similar impedance of different magnitude as viewed from the other winding. As such, they can function over a broad band of frequencies, such as the audio band from 30-1500 c.p.s. without the primary inductance winding resistance, core losses, or leakage inductance producing appreciable variations in the reflected impedance, as determined by the turns ratio.

Air-core transformers, on the other hand, depart so widely from the ideal transformer that the turns

ratio is of little value in predicting their performance. Instead, the primary and secondary self-inductances and their mutual inductance, involving the coefficient of coupling k , serve to determine their behavior.

It is found preferable in this case to reflect the impedance connected across one coil as an equivalent impedance in *series* with the other coil; the reflected impedance appears as the reciprocal of the actual impedance employed.

The air-core transformer has such large leakage inductances and magnetizing current that the reactances it introduces in a circuit,

in addition to its impedance-reflecting properties, makes its behavior vary with frequency. Hence it is best operated in conjunction with tuning capacitors, and consequently functions best over a *narrow* frequency range, although this range can be adjusted to any portion of the spectrum desired by varying the tuning capacitor.

In this assignment a brief and elementary analysis of the r-f amplifier stage was given to illustrate the analysis of the air-core transformer. More detailed discussions will appear in subsequent assignments, as well as the analysis of the double-tuned i-f amplifier.



EXERCISE PROBLEMS

INDUCTIVE COUPLING

1. An iron-core transformer has a secondary winding of 24,000 turns. If 10 volts is applied to the primary and 80 volts is measured across the secondary terminals, how many turns are on the primary winding?
2. A tube is used in such a manner that it requires a load-resistance of $6,000\Omega$. If the actual load is only 15 ohms, what turns ratio would be required for the proper matching transformer?
3. The turns ratio between the primary and secondary of an output transformer is 50 to 1. The load resistance is 40 ohms. What is the value of the input resistance for matching impedances?
4. Given an iron-core transformer with a turns ratio of 1 to 10, primary to secondary. Connect a load resistance across the secondary which draws a current of 0.3 ampere. What is the primary current?
5. An audio transformer has two secondary windings and a primary winding. Turns ratio between the primary and the first secondary is 7:1; and the load resistance is 600 ohms. Turns ratio between the primary and the second secondary is 11:1; and the load resistance is 40 ohms. Calculate the total resistance reflected into the primary.
6. Given $L_p = 25\mu h$, $L_s = 5\mu h$, $K = .02$. Find M .
7. Given $L_p = 25\mu h$, $L_s = 5\mu h$, $K = .01$. Find M .
8. Given $L_p = 25\mu h$, $L_s = 5\mu h$, $M = .25\mu h$. Find K .
9. Given $L_p = 20\mu h$, $L_s = 9\mu h$ connected in series with fields opposing. The overall inductance measured is $L = 25\mu h$. Calculate the value of M .
10. See Fig. 24 of assignment. $L_p = 150\mu h$, $M = 15\mu h$, $R_s = 125\Omega$ and $f = 10$ mc/s. Find the total impedance looking into the primary including "coupled impedance." Resonance assumed.

ANSWERS TO EXERCISE PROBLEMS

1. 3,000 turns
2. 20:1
3. 100,000 Ω
4. 3 amp.
5. 4160 Ω
6. 0.224 μ h
7. .112 μ h
8. .0224
9. 2 μ h
10. 36,800

INDUCTIVE COUPLING

EXAMINATION

1. In an iron-core type of transformer, a load is connected to the secondary, and it is found that 1.5 amperes flow in the primary circuit. The secondary load is then disconnected, and it is found that about 0.075 ampere still flows in the primary circuit. Explain.

2. (A) The same iron-core transformer has a primary winding containing 2,000 turns. When 20 volts are applied to this winding, 120 volts are measured across the secondary. How many turns are there in the secondary coil?

(B) A load resistance is connected across the secondary that draws 0.2 ampere. What is the reflected primary current?

3. An alternator has an internal resistance of 15 ohms, and feeds a load of 4,000 ohms. What is the proper turns ratio for an impedance matching transformer to obtain maximum power output?

4. An audio transformer has three secondaries and a primary. The turns ratio between the primary and the first secondary is 5:1, and the secondary load resistance is 500 ohms; the turns ratio to the second secondary is 8:1 and the secondary load is 50 ohms; and the turns ratio to the third secondary is 15:1 and the secondary load is 10 ohms.
Calculate the total resistance reflected into the primary.

INDUCTIVE COUPLING

EXAMINATION, Page 3.

6. *(Continued)*
7. Given $L_p = 120 \mu\text{h}$; $L_s = 480 \mu\text{h}$; and $M = 300 \mu\text{h}$.
(A) Calculate the coefficient of coupling.

(B). What is wrong with this result?
8. Suppose the coefficient of coupling k in the above problem were 0.01. What would be the value for M ?
9. In a television i-f transformer, $L_p = 15 \mu\text{h}$ and $L_s = 6 \mu\text{h}$.
(A) They are connected in series with their magnetic fields opposing. The overall inductance measured is $L = 20.5 \mu\text{h}$. What is M ?

(B) What is the coefficient of coupling k ?

(C) What will be the total L if the connections of one coil are reversed?

INDUCTIVE COUPLING

EXAMINATION, Page 4.

10. Refer to Fig. 24 in the text. Suppose $L_p = 200 \mu\text{h}$; $M = 20 \mu\text{h}$; $R_s = 30 \text{ ohms}$, and $f = 5 \text{ mc}$. What^p is the total impedance looking into the primary winding, including the equivalent SERIES impedance of the secondary circuit?
Note: - L_s is assumed to tune with C_s at 5 mc.

