



SECTION 2

**ADVANCED
PRACTICAL
RADIO ENGINEERING**

TECHNICAL ASSIGNMENT

COMPLEX NOTATION

Copyright 1950 by
Capitol Radio Engineering Institute
Washington, D.C.

233 E

- TABLE OF CONTENTS -

COMPLEX NOTATION

	Page
SCOPE OF ASSIGNMENT	1
FUNDAMENTAL CONSIDERATIONS	1
<i>VECTORS</i>	1
METHODS OF CONVERSION	2
<i>CONVERTING FROM RECTANGULAR TO POLAR FORM</i>	2
<i>CONVERTING FROM POLAR TO RECTANGULAR FORM</i>	3
POLAR FORM	5
<i>MULTIPLICATION IN THE POLAR FORM</i>	5
<i>DIVISION IN THE POLAR FORM</i>	6
COMPLEX FORM	7
<i>INVOLUTION IN THE COMPLEX FORM</i>	7
<i>EVOLUTION IN COMPLEX FORM</i>	7
CALCULATIONS	9
<i>THE SLIDE RULE IN COORDINATE TRANSFORMATIONS</i>	9
<i>THE ADMITTANCE METHOD</i>	10
SOME GENERAL APPLICATIONS OF COMPLEX NOTATION	13
<i>LCR NETWORKS</i>	13
<i>DESIGN OF T-NETWORKS</i>	17
<i>THE π NETWORK</i>	20
<i>DESIGN OF A π NETWORK</i>	20

SCOPE OF ASSIGNMENT

The preceding assignment covered the use of the operator j in defining the rectangular coordinates of a vector. The definition of and the geometric relationship between the real and the j parts of the complex number were also established. In the rectangular coordinate system the vector is defined in terms of the vertical and horizontal components; that is, by stating the abscissa and ordinate of the terminal point of the vector. The rectangular form is not always convenient or desirable, in fact, for certain mathematical processes this form can be quite cumbersome. It is therefore necessary in this assignment to investigate the application of the operator j to the polar coordinate system.

FUNDAMENTAL CONSIDERATIONS

VECTORS.—In an earlier assignment it was explained that a vector could be defined explicitly by stating the magnitude and direction of the vector. In Fig. 1 the vector A can be defined by stating the length of A in units and the angle θ between A and the horizontal axis ox' . It is evident that A is the hypotenuse of a right triangle having sides X and R and the absolute magnitude of A is given by the equation $A = \sqrt{R^2 + X^2}$. Since R and X are squared it makes no difference whether the sign of X is positive or negative since squaring will always make the sign positive.

The equation $A = \sqrt{R^2 + X^2}$ only partly defines the vector since A could be in any one of four quadrants and thus could make any one of four angles with respect to the positive X or polar axis. It remains

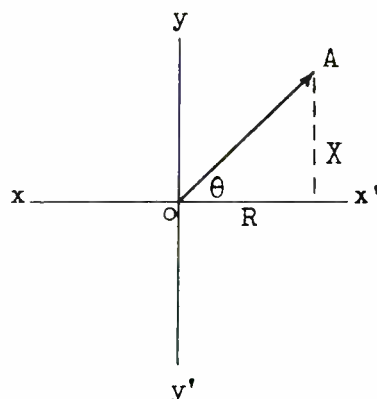

Fig. 1. —Vector Components.

to determine the direction of A to explicitly define the vector. From trigonometry, θ in Fig. 1 is the angle whose tangent is X/R , written $\theta = \text{Tan}^{-1} X/R$. Vector A is now definitely established both as to length and direction IN REFERENCE TO AN ARBITRARILY SELECTED REFERENCE LINE. Mathematically A is defined in the polar form by the equation

$$A = \sqrt{R^2 + X^2}, \quad \angle \text{Tan}^{-1} X/R$$

which may also be written

$$A = |A| \angle \theta$$

where $|A|$ is the absolute magnitude and θ the angle.

Quite often a vector may be ex-

pressed in the polar form by inspection. For example, a voltage of 110 volts leads a current of 5 amperes by an angle of 40° . Placing the current along the polar axis (0°) the polar coordinates of I are $5 \angle 0^\circ$ and for the voltage $110 \angle 40^\circ$. The angle of E is positive and less than 90° which places E in the first quadrant. If the voltage had been taken along the polar axis the notation would have been $E = 110 \angle 0^\circ$ and $I = 5 \angle -40^\circ$. The negative angle of I indicates the angle is measured in a clockwise direction from the polar axis and since the angle is less than -90° it definitely places I in the fourth quadrant.

METHODS OF CONVERSION

CONVERTING FROM RECTANGULAR TO POLAR FORM.—The rectangular form of a vector is easily converted to the polar form. If a voltage equals $6 + j8$ volts, the absolute magnitude of E is $\sqrt{6^2 + 8^2}$ or 10 volts, and $\theta = \tan^{-1} 8/6 = 53.1^\circ$. In polar form $E = 10 \angle 53.1^\circ$. Another example; determine the polar form for the voltage $-6 + j8$ volts. The magnitude of E is $\sqrt{6^2 + 8^2}$ or 10 volts and $\theta = \tan^{-1} 8/6 = 53.1^\circ$. But an inspection of the rectangular form shows the abscissa (real part) of E is negative while the ordinate (imaginary part) is positive. From an earlier lesson when X is negative and Y is positive the vector must lie in the second quadrant. Therefore the real angle θ in reference to the polar axis is $180 - 53.1$ or 126.9° . The polar form of the voltage $-6 + j8$ is then $10 \angle 126.9^\circ$. Fig. 2 illustrates the conversion graphically. Until the student becomes thoroughly familiar with the

conversion process it is suggested that the correctness of the conversion always be checked graphically.

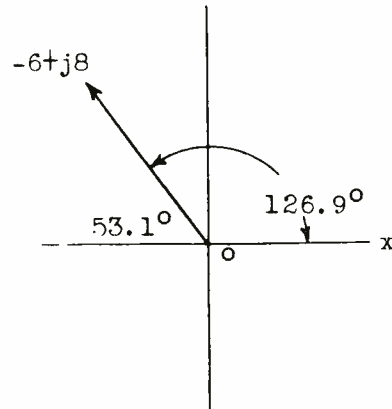

Fig. 2.—Converting graphically.

Determine the polar form for the vector $E = -15 - j8$. $|E| = \sqrt{(-15)^2 + (-8)^2} = 17$. $\theta = \tan^{-1} -8/-15 = 28.1^\circ$. But the real and j parts of E are both negative which places E in the third quadrant so $\theta = 180^\circ + 28.1^\circ$ and the polar form of E is $17 \angle 208.1^\circ$. The conversion is shown in Fig. 3.

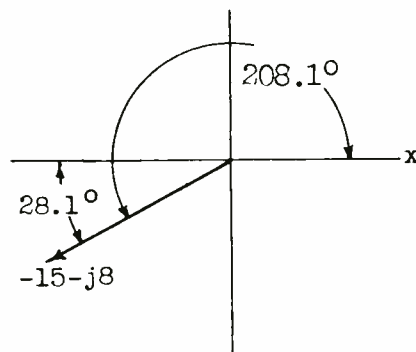

Fig. 3.—Rectangular Coordinates of a rotating vector in 3rd. quadrant.

For the fourth quadrant consider the voltage $7.07 - j7.07$ volts. $E = \sqrt{7.07^2 + (-7.07)^2} = 10$ volts. $\theta = \tan^{-1} -7.07/7.07 = 45^\circ$. But the ordinate is negative and the abscissa positive which places the vector in the fourth quadrant and $\theta = 360^\circ - 45^\circ = 315^\circ$ or $E = 10 \angle 315^\circ$. The conversion is shown in Fig. 4.

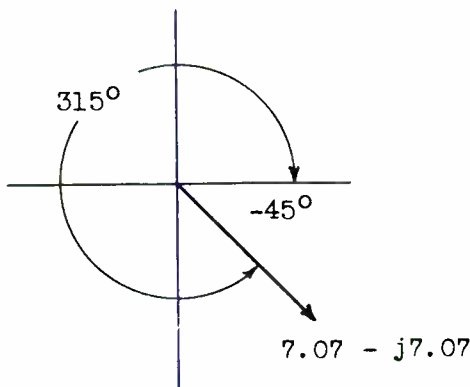

Fig. 4. — Rectangular coordinates of a rotating vector in 4th quadrant.

It should be noted that θ can be expressed as either positive or negative with respect to the polar axis. In the last example θ could be expressed as -45° measured in a clockwise direction from the polar axis or the positive angle 315° may be used indicating the angle is measured in a counter-clockwise direction. The angles 315° and -45° are said to be coterminal. Whether or not a negative or positive angle is used is a matter of convenience. When the vector lies in the first, second, or third quadrant it is conventional to use the positive angle while the negative angle is ordinarily used for the vectors in the fourth quadrant. There is no hard

or fast rule and either method is mathematically correct. Since most electrical vectors appear in the first and fourth quadrants the writer leans toward positive angles in the first quadrant and negative angles in the fourth. In either case the signs of the real and j parts of the rectangular form definitely locate the quadrant in which the vector should appear and a simple sketch will give the essential clue to the correct angle to use. The magnitude of the vector is not affected by its quadrantal position.

CONVERTING FROM POLAR TO RECTANGULAR FORM. — Polar vectors are very convenient for all algebraic manipulations EXCEPT ADDITION AND SUBTRACTION. As shown in the preceding assignment addition and subtraction are very simple processes when the rectangular form is used. Fig. 5 shows the familiar graph-

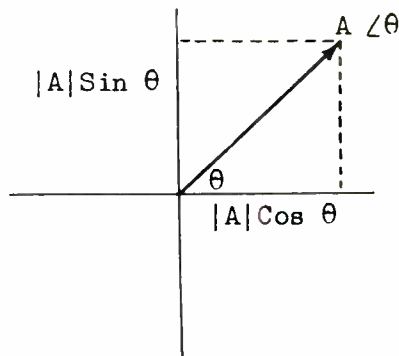

Fig. 5. — Graphical representation.

ical representation of a vector, the first quadrant being used for convenience. The problem is to determine the rectangular coordinates from the given polar coordinates. It is a simple problem in trigono-

metry where the hypotenuse and one angle of a right triangle are given. It is evident from Fig. 5 that the two sides of the right triangle will fall on the real and j axis when the triangle is placed in the standard position. The side coinciding with the real axis is $A \cos \theta$ while the side representing the j axis projection is $A \sin \theta$. Thus the polar vector $A \angle \theta$ can be expressed in the rectangular form by

$$A = |A| \cos \theta + |A| j \sin \theta.$$

which can be simplified by factoring to

$$A = |A| (\cos \theta + j \sin \theta)$$

For example, express the vector $A = 10 \angle 45^\circ$ in the rectangular form.

$$\begin{aligned} A &= |A| (\cos 45^\circ + j \sin 45^\circ) \\ \sin 45^\circ &= \cos 45^\circ = .707 \\ A &= 10 (.707 + j .707) \\ &= (10 \times .707) + j(10 \times .707) \\ &= 7.07 + j7.07 \end{aligned}$$

Fig. 6 shows the graphical representation.

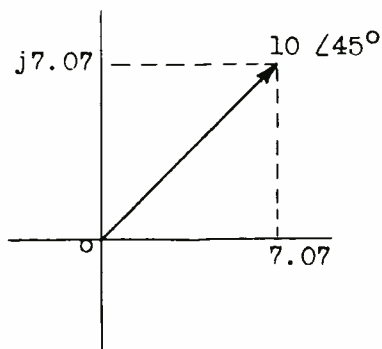

Fig. 6.—Graphical representation of a rotating vector in first quadrant.

As a further example convert $A = 10 \angle -45^\circ$ to the rectangular form. The angle -45° places the vector in the fourth quadrant and from the preceding assignment $\cos \theta$ is positive and $\sin \theta$ is negative.

$$\begin{aligned} A &= 10 (\cos -45^\circ + j \sin -45^\circ) \\ &= 10 (.707 + j - .707) \\ &= 7.07 - j7.07 \end{aligned}$$

Fig. 7 shows the graphical representation.

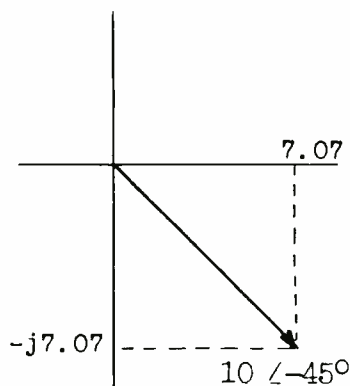

Fig. 7.—Graphical representation of a rotating vector in fourth quadrant.

It will be observed that the correct algebraic sign for each part of the rectangular expression is determined by the proper choice of sign for the accompanying trigonometric function. This will never cause difficulty or confusion if the student will memorize the sign of the sine, cosine, and tangent in each quadrant as shown in Fig. 8.

Convert the vector $15 \angle 130^\circ$ to the rectangular form.

$$\begin{aligned} A &= 15 (\cos 130^\circ + j \sin 130^\circ) \end{aligned}$$

Observing the signs of the trigonometric functions from Fig. 8.

$$\begin{aligned}
 A &= 15 (-\cos 130^\circ + j \sin 130^\circ) \\
 &= 15 (-\cos 50^\circ + j \sin 50^\circ) \\
 &= 15 (-.643 + j .766) \\
 &= [15 \times (-.643)] + [j 15 \times .766] \\
 &= -9.64 + j 11.49
 \end{aligned}$$

A diagram will verify the above conversion.

Quad. 2	Quad. 1
Sin +	Sin +
Cos -	Cos +
Tan -	Tan +
Sin -	Sin -
Cos -	Cos +
Tan +	Tan -
Quad. 3	Quad. 4

Fig. 8.—Table for the conversion of trigonometrical functions in different quadrants.

EXERCISES:

Convert to polar form:

- $-22 + j30$
- $5 - j50$
- $.06 - j.025$
- $755 + j875$
- $-8 - j6$
- $-1 - j3$
- $3 - j5$
- $9 - j10$
- $0 + j40$
- $-32 - j0$
- A voltage of 50 volts at 30°
- A current of 10 amperes at -75°
- A current of 21 amperes leading a voltage of 100 volts by 21° when the voltage is at -15° .
- A pure capacity reactance of 98 ohms.

- A capacity reactance of 12 ohms, a resistance of 25 ohms, and an inductive reactance of 40 ohms.

Convert to rectangular form:

- $8 \angle 30^\circ$
 - $94.5 \angle 58^\circ$
 - $300 \times 10^5 \angle 51.7^\circ$
 - $440 \angle 201^\circ$
 - $220 \angle -159^\circ$
 - $14.6 \angle -52.6^\circ$
 - $116 \angle 238^\circ$
 - $110 \angle 23.8^\circ$
 - $.006 \angle 180^\circ$
 - $90 \angle -90^\circ$
- Add:
- $10 + j15$ and $10 \angle 30^\circ$
 - $25 - j40$ and $30 \angle 40^\circ$
 - $20 \angle -30^\circ$ and $10 \angle 80^\circ$
 - $.09 \angle -30^\circ$ and $1.2 \angle -140^\circ$
 - $-7 - j20$ and $16 \angle 90^\circ$

POLAR FORM

MULTIPLICATION IN THE POLAR FORM.—It was shown previously that multiplication in the rectangular form is somewhat complicated. Multiplication in the polar form is quite simple. The vector A in the polar form is $|A| \angle \theta$ where $|A|$ is the magnitude or MODULUS and θ is the angle or ARGUMENT. MULTIPLICATION OF TWO VECTORS IN POLAR FORM IS PERFORMED BY MULTIPLYING THE MAGNITUDES OR MODULI AND ADDING THE ANGLES OR ARGUMENTS.

$$A \angle \theta \cdot B \angle \phi = AB \angle \theta + \phi$$

The above is a general expression and applies to all vectors in the polar form. To illustrate the

process with numerical values multiply $10 \angle 30^\circ$ by $15 \angle 45^\circ$. The product is

$$10 \times 15 / \underline{30^\circ + 45^\circ} = 150 \angle 75^\circ$$

Multiply $6 \angle -25^\circ$ by $8 \angle 55^\circ$
 $6 \times 8 / \underline{-25^\circ + 55^\circ} = 48 \angle 30^\circ$

DIVISION IN THE POLAR FORM.—

Division is the inverse of multiplication, so the process of multiplication is reversed. TO DIVIDE VECTORS IN THE POLAR FORM DIVIDE THE MAGNITUDE OF THE DIVIDEND BY THE MAGNITUDE OF THE DIVISOR AND SUBTRACT THE ANGLE OF THE DIVISOR FROM THE ANGLE OF THE DIVIDEND.

To illustrate, divide $48 \angle 30^\circ$ by $16 \angle 15^\circ$

$$|48/16| \underline{30^\circ - 15^\circ} = 3 \angle 15^\circ$$

Divide: $125 \angle 25^\circ$ by $25 \angle 55^\circ$
 $|125/25| \underline{25^\circ - 55^\circ} = 5 \angle -30^\circ$

The general form for $A \angle \theta$ divided by $B \angle \phi$ is $|A/B| \angle \theta - \phi$.

EXERCISES:

Multiply:

31. $30 \angle 20^\circ$ by $24 \angle 37^\circ$
 32. $.06 \angle -15^\circ$ by $.003 \angle -64^\circ$
 33. $63 \angle 25^\circ$ by $156 \angle 185^\circ$
 34. $36 \angle 36^\circ$ by $22 \angle -30^\circ$
 35. $124 \angle -175^\circ$ by $.5 \angle 200^\circ$
- 36 to 40. In exercises 31 to 35 divide the first vector by the second. It must be thoroughly understood that the expression for the polar vector $A \angle \theta$ does not indicate a product. It is only a form of notation used to express the magnitude and direction of a vector. A variation of the form $A \angle \theta$ is the notation $A \text{ Cis } \theta$ which is an abbreviation for $A (\text{Cos } \theta + j \text{ Sin } \theta)$.

It should be evident by this time that the rectangular form is more suitable for addition and subtraction of vectors while the polar form is to be preferred for multiplication and division. The next step is involution (raising to a power) and evolution (extracting a root) of vectors. The rectangular form is not very well suited to these operations. The process whereby polar vectors are multiplied by multiplying the magnitudes and ADDING the angles and divided by dividing the magnitudes and SUBTRACTING the angles suggests that the angle has properties similar to an exponent, and the magnitude properties of the co-efficient in algebraic functions. Thus $3X^2$ times $4X^3$ is carried out by multiplying the coefficients $3 \times 4 = 12$ and adding the exponents of X giving a result $12X^{2+3} = 12X^5$. The above process is practically the same as that used when multiplying vectors in the polar form. $4X^6$ divided by $2X^2 = 4/2$ times X^{6-2} or $2X^4$ which is identical to the process used in dividing vectors in the polar form. By mathematics beyond the scope of this course the above relationship can be demonstrated by proving that

$$e^{j\theta} = \text{Cos } \theta + j \text{ Sin } \theta$$

where e is 2.718...the base of natural or Naperian logarithms. A complex quantity A may therefore be expressed in any one of the following forms:

$$A = A \angle \theta = A (\text{Cos } \theta + j \text{ Sin } \theta) = Ae^{j\theta}$$

The last expression $Ae^{j\theta}$ shows the exponential character of the angle and indicates why it is correct to add the angles when multiplying

polar vectors and to subtract the angles when dividing. $Ae^{j\theta}$ is called an EXPONENTIAL VECTOR and, as will be shown later, is a form well suited for the processes of involution and evolution.

Since $Ae^{j\theta} = A (\cos \theta + j \sin \theta)$ then $Ae^{-j\theta}$ must equal $A (\cos \theta - j \sin \theta)$. The general expression for multiplying exponential vectors is

$$(Ae^{j\theta}) \cdot (Be^{j\phi}) = AB e^{j(\theta + \phi)}$$

and for division

$$(Ae^{j\theta}) / (Be^{j\phi}) = (A/B) e^{j(\theta - \phi)}$$

From the foregoing it is evident there are several different methods of expressing a vector quantity. For example, by a single letter Z where Z represents the complete vector quantity; in the rectangular form $R + jX$; in the polar form $Z \angle \theta$, Z in this case representing the magnitude; in the exponential form $Ze^{j\theta}$ where Z again represents the magnitude; in the circular or trigonometric form, often abbreviated $Z \text{ Cis } \theta$, $Z (\cos \theta + j \sin \theta)$. θ is usually expressed in degrees although the angle may be expressed in radians. Thus $36^\circ = \pi/5$ radians and Z might be written:

$$100 \angle \pi/5 = 100 (\cos \pi/5 + j \sin \pi/5) = 100 e^{j\pi/5}$$

The form to be used is normally decided by convenience. The rectangular form is best suited to addition and subtraction, the polar form to multiplication and division, and the exponential form to multiplication, division, involution, and evolution. The disadvantage of the exponential form is that it has no geometric representation and must be

taken as a pure abstract expression that has no physical analogue.

COMPLEX FORM

INVOLUTION IN THE COMPLEX FORM.-

In complex notation the process of raising to a power is simply a case of using the vector the requisite number of times as a factor. Thus $(R + jX)^2 = (R + jX)(R + jX)$
 $(R - jX)^3 = (R - jX)(R - jX)(R - jX)$
 or $(R - jX)^n$ means $(R - jX)$ used as a factor n times.

If the rectangular vector $4 + j3$ is changed to the polar form $5 \angle 36.85^\circ$ the process of involution or evolution is much less cumbersome. The process is also simplified if the exponential form $5e^{j36.85^\circ}$ is used. Thus $(5e^{j36.85^\circ})^2$ is performed by squaring the coefficient and multiplying the exponent by 2 giving $25e^{j(2 \times 36.85^\circ)} = 25e^{j73.7^\circ}$. This is readily converted back to the polar form as $25 \angle 73.7^\circ$.

TO RAISE A VECTOR IN THE POLAR FORM TO ANY POWER RAISE THE MAGNITUDE TO THE REQUIRED POWER AND MULTIPLY THE ANGLE BY THE INDEX OF THE POWER.

If the angle is negative as it would be if the vector is $4 - j3$ the square would be $(5e^{-j36.85^\circ})^2 = 25e^{-j2 \times 36.85^\circ} = 25e^{-j73.7^\circ} =$

$$25 \angle -73.7^\circ.$$

It is evident that the polar and exponential forms are best suited to involution because they are most amenable to the algebraic laws.

EVOLUTION IN THE COMPLEX FORM.— Evolution, the process of finding a root, is just the reverse of involution. Consider the vector

$$169e^{j45.22^\circ}$$

To extract any root of this vector the laws of algebra are satisfied by finding the required root of the coefficient of e and dividing the exponent of e by the index of the root. Thus

$$\sqrt[3]{169e^{j45 \cdot 22^\circ}} = 13e^{j22 \cdot 61^\circ} = 13/22.61^\circ$$

The general form for this process is

$$\sqrt[n]{Ze^{j\theta}} = \sqrt[n]{Z} \left(e^{j(\theta/n)} \right) = \sqrt[n]{Z} \angle \frac{\theta}{n}$$

If θ is negative the process is unchanged but the angle of the root will be negative. For example, the cube root of $27 \angle -45^\circ$ is $3 \angle -15^\circ$.

Evolution of vectors in the rectangular form is somewhat more involved and is based on the axiom: IF TWO COMPLEX NUMBERS ARE EQUAL THEIR REAL PARTS ARE EQUAL AND THEIR J PARTS ARE EQUAL. From this axiom if $R + jX = 10 + j15$ then $R = 10$ and $jX = 15$. To illustrate the method the square root of the vector $119 + j120$ will be extracted. By the above axiom

$$\sqrt{119 + j120} = A + jB \quad (1)$$

where $A + jB$ is the root.

Square both sides of (1) to remove the radical

$$119 + j120 = (A + jB)^2 = A^2 + j2AB - B^2 \quad (2)$$

In (2), $A^2 - B^2$ is the real part and $j2AB$ is the imaginary part.

By the above axiom

$$119 = A^2 - B^2 \quad (3)$$

and

$$j120 = j2AB \quad (4)$$

dividing (4) by $j2$

$$60 = AB$$

dividing by A

$$B = 60/A \quad (5)$$

Substituting the value of B from (5) for B in (3)

$$119 = A^2 - (60/A)^2$$

$$119 = A^2 - \frac{3600}{A^2}$$

Multiplying by A^2

$$119A^2 = A^4 - 3600$$

Transposing

$$A^4 - 119A^2 - 3600 = 0$$

Factoring

$$(A^2 - 144)(A^2 + 25) = 0$$

If

$$A^2 - 144 = 0 \text{ then } A^2 = 144$$

and

$$A = \sqrt{144} = \pm 12 \quad (6)$$

If

$$A^2 + 25 = 0 \text{ then } A^2 = -25$$

and

$$A = \pm \sqrt{-25} \quad (7)$$

The roots in (7) are rejected since by (1) A is real and cannot be imaginary. Substituting the value of A from (6) in (5)

$$B = 60/\pm 12$$

$$B = \pm 5$$

Therefore the square roots of $119 + j120$ are either $(12 + j5)$ or $(-12 - j5)$. It is not unusual for the expression $119 + j120$ to have two roots since the number of possible roots is indicated by the index of the roots.

It is apparent that the easiest method of finding the root of a vector in the rectangular form is to first convert to the polar form, extract the desired root and then convert back to rectangular coordinates if that is the desired form.

EXERCISES:

Express the following in the rectangular, polar, and exponential form:

41. $15 \angle 30^\circ$

42. $10e^{j45^\circ}$

43. $100e^{j\pi}$

44. $40 (\cos 60^\circ + j \sin 60^\circ)$

45. $5 \text{ Cis } - 53.08^\circ$

46. $4 + j3$

47. $12e^{-j45^\circ}$

Extract the indicated root:

- 48. $\sqrt{155 \angle 30^\circ}$
- 49. $\sqrt[3]{210 \angle -117^\circ}$
- 50. $\sqrt{12.4 - j8.5}$
- 51. $\sqrt[4]{-21 - j14}$
- 52. $(54 \angle -24^\circ)^{-1/2}$

Raise to the indicated power:

- 53. $(2 + j3)^2$
- 54. $(8/51.2)^2$
- 55. $(50 \text{ Cis } 30^\circ)^3$
- 56. $(7 \angle -50^\circ)^2$
- 57. $(9e^{j27^\circ})^4$
- 58. $(10/10^\circ)^{3/2}$
- 59. $(2e^{-j5^\circ})^{-4/3}$
- 60. $(10/-20^\circ)^4$

CALCULATIONS

THE SLIDE RULE IN COORDINATE TRANSFORMATIONS.—The use of a vector slide rule greatly facilitates the transformation of vectors from the polar to the coordinate form and vice versa. All calculations with complex numbers in this and the preceding assignment have been performed with the aid of such a rule. The student possessing a rule with scales arranged for vector transformation has a valuable tool. The log log vector and log log decitrig rules are particularly suited to this type of work. However for the student who has only the regular Mannheim polyphase rule vector transformations can be made by using a few simple mathematical devices.

From trigonometry the following relations can be readily established for Fig. 9. $\theta = \text{Tan}^{-1} X/R$ and $Z = X/\text{Sin } \theta$. Suppose it is desired to transform the rectangular vector $3 + j4$ to the polar form. If the right triangle theorem is used ($\sqrt{3^2 + 4^2}$) it involves a sum which is not readily solved by the rule. However it is a straight forward process to calculate θ . In this

case it is the angle whose tangent is $4/3$ or 1.333 . From the rule $\text{Tan}^{-1} 1.333$ is $\angle 53.15^\circ$. Transfer this angle to the sine scale and read the value of Z on the A scale directly above the X value 4 on the

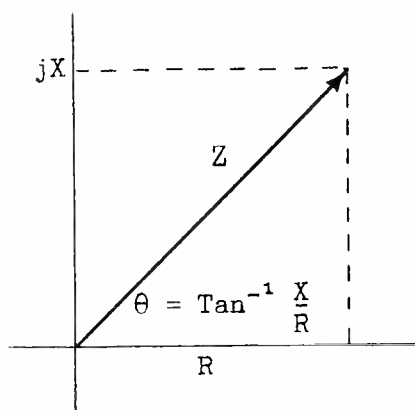

Fig. 9.—Example for slide rule calculations.

B scale. This is the process of finding Z from $X/\text{Sin } \theta$. Thus $3 + j4 = 5 \angle 53.15^\circ$. This method applies to all cases where the tangents of θ lie between .1 and 10. For other cases there are special methods that will not be discussed here.

By a reversal of the process the polar form $5 \angle 53.15^\circ$ can be transposed to the rectangular form. Set the rule up for the sine of 53.15° and read the X value 4 on the B scale under the 5 on the A scale. Reset the rule for the cosine of 53.15° and read the R value 3 on the B scale under 5 on the A scale. Since the angle is positive and in the first quadrant the rectangular form of the vector is $3 + j4$.

The student is urged to use the rule as often as possible in all such calculations.

POWER DETERMINATION FROM COMPLEX QUANTITIES.—The power in a circuit may be determined from

the current and the voltage in either the polar or rectangular form. In the polar form power is equal to the product of the absolute magnitude of E and I times the cosine of the PHASE ANGLE DIFFERENCE. This will be recognized as practically the same method as that studied in an earlier assignment where $P = EI \cos \theta$. If $E = 110 \angle 0^\circ$ and $I = 5 \angle 30^\circ$ then $P = 110 \times 5 \times \cos 30^\circ = 110 \times 5 \times .866 = 477$ watts. If $E = 110 \angle -25^\circ$ and $I = 5 \angle 30^\circ$ then $P = 110 \times 5 \times \cos (-25^\circ - 30^\circ) = 110 \times 5 \times \cos -55^\circ = 110 \times 5 \times .574 = 316$ watts. Only the magnitude of the angle is important since $\cos (-\theta) = \cos \theta$ as long as θ is between $+90$ and -90° .

In the rectangular form the power is determined by adding the product of the real parts to the product of the imaginary parts without regard to the j in the computations. For example, if $E = 3 + j4$ and $I = 6 + j7$ then $P = (3 \times 6) + (4 \times 7) = 46$ watts. This may be checked by transforming the vectors to the polar form and solving for P. $3 + j4 = 5 \angle 53.15^\circ$ and $6 + j7 = 9.22 \angle 49.4^\circ$ $P = 5 \times 9.22 \times \cos (53.15^\circ - 49.4^\circ) = 5 \times 9.22 \cos 3.75^\circ = 5 \times 9.22 \times .99786 = 46$ watts.

In finding the product of the real and j parts algebraic multiplication must be used, that is, the signs of the terms must be considered. If $E = 3 - j4$ and $I = 6 - j7$ then $P = (3 \times 6) + (-4 \times -7) = 18 + 28 = 46$ watts. If $E = -3 + j4$ and $I = -6 + j7$, then $P = (-3 \times -6) + (4 \times 7) = 18 + 28 = 46$ watts but if $E = -3 + j4$ and $I = 6 + j7$ then $P = (-3 \times 6) + (4 \times 7) = -18 + 28 = 10$ watts.

The method used to determine power is a matter of convenience. Power calculations at radio frequen-

cies are usually simplified by the fact that at resonance unity power factor prevails; that is, θ equals zero degrees and $\cos \theta = 1$.

THE ADMITTANCE METHOD.—In any circuit the impedance may be expressed by the formula

$$Z = E/I$$

where E is the applied voltage, I is the circuit current and Z is the impedance AT THE POINT WHERE E AND I ARE MEASURED. In Fig. 10 the current in each branch is equal to E/Z_b where Z_b is the branch impedance. The total current in the combination is

$$I = I_1 + I_2 + I_3 \dots\dots\dots I_n$$

Since the branch currents are equal to E/Z_b then

$$I = \frac{E}{Z_1} + \frac{E}{Z_2} + \frac{E}{Z_3} \dots\dots\dots \frac{E}{Z_n}$$

Factoring

$$I = E \left(\frac{1}{Z_1} + \frac{1}{Z_2} + \frac{1}{Z_3} \dots\dots\dots \frac{1}{Z_n} \right)$$

Dividing by E

$$\frac{I}{E} = \frac{1}{Z_1} + \frac{1}{Z_2} + \frac{1}{Z_3} \dots\dots\dots \frac{1}{Z_n}$$

Since $Z = E/I$ then $I/E = 1/Z$. The reciprocal of the impedance is the admittance Y or $Y = 1/Z = I/E$. Therefore

$$Y = Y_1 + Y_2 + Y_3 \dots\dots\dots Y_n$$

For a two branch parallel circuit

$$Y = Y_1 + Y_2$$

or

$$\frac{1}{Z} = \frac{1}{Z_1} + \frac{1}{Z_2}$$

Multiplying by the common de-

nominator ZZ_1Z_2

$$Z_1Z_2 = ZZ_2 + ZZ_1$$

Factoring

$$Z_1Z_2 = Z (Z_1 + Z_2)$$

Dividing by

$$(Z_1 + Z_2) \quad Z = \frac{Z_1 Z_2}{Z_1 + Z_2}$$

This final equation shows that the product divided by the sum holds true for impedances in parallel just as it does for resistances in parallel. However in the equation just developed it must be remembered that Z is a vector quantity and all the operations must conform to the rules of vector algebra. As a numerical

$$Z = 7.07 - j7.07 \text{ ohms}$$

$$Y_1 = \frac{1}{Z_1} = \frac{1}{3 + j4} = \frac{3 - j4}{25} = .12 - j.16 \text{ mho.}$$

$$Y_2 = \frac{1}{Z_2} = \frac{1}{7.07 - j7.07} = \frac{7.07 + j7.07}{100} = .0707 + j.0707 \text{ mho.}$$

$$Y = Y_1 + Y_2 = .12 - j.16 +$$

$$.0707 + j.0707 = .1907 - j.0893 \text{ mho.}$$

$$Z = \frac{1}{Y} = \frac{1}{.1907 - j.0893} = 4.28 + j2.04 \text{ ohms}$$

Solving by the product over sum method.

$$Z_1 = 3 + j4 = 5 \angle 53.1^\circ$$

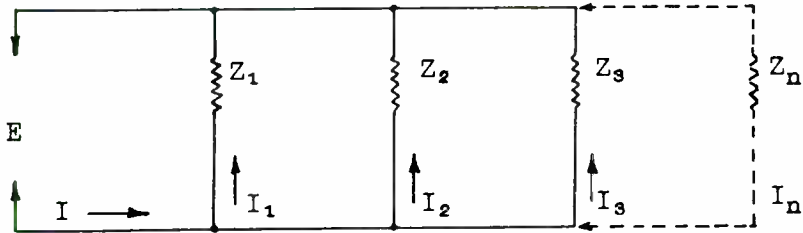

Fig. 10.—Parallel impedances solved by vector algebra.

example the impedance of a two branch parallel circuit will be determined first by the admittance method and then by the product over sum method. The circuit and circuit constants are shown in Fig. 11. For the inductive branch

$$Z_1 = 3 + j4 \text{ ohms}$$

For the capacitive branch

$$Z_2 = 7.07 - j7.07 = 10 \angle -45^\circ$$

$$Z_1 + Z_2 = 3 + j4 + 7.07 - j7.07 = 10.07 - j3.07 = 10.55 \angle -16.95^\circ$$

$$Z = \frac{Z_1 Z_2}{Z_1 + Z_2} = \frac{5 \angle 53.1^\circ \cdot 10 \angle -45^\circ}{10.55 \angle -16.95^\circ}$$

$$= 4.74 \angle 25.05^\circ = 4.28 + j2.04 \text{ ohms.}$$

The choice of methods is a matter of convenience since either will produce the same result. In general the product over sum method is preferred for two branch circuits and the admittance method for circuits of three or more branches. If a third branch $Z_3 = 4 + j10$ ohms is added to the two branches in Fig. 11 then

$$Y_3 = \frac{1}{4 + j10} = \frac{4 - j10}{116} = .0344 - j.0862 \text{ mho.}$$

$$Y = .0344 - j.0862 + .1907 - j.0893 = .2251 - j.1755 \text{ mho.}$$

$$Z = \frac{1}{Y} = \frac{1}{.2251 - j.1755} = 2.76 + j2.15$$

The admittance method can be continued indefinitely for any number of parallel branches but the

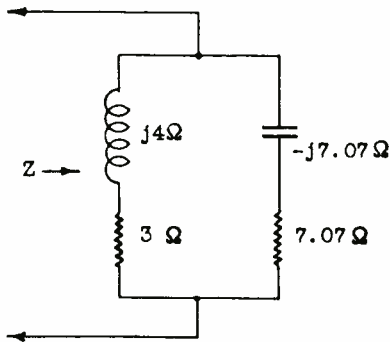

Fig. 11.—Numerical example for impedance of a two branch parallel circuit.

product over sum method becomes more and more complicated as the number of branches increase. For a three branch parallel circuit the product over sum formula becomes

$$Z = \frac{Z_1 Z_2 Z_3}{Z_1 Z_2 + Z_1 Z_3 + Z_2 Z_3}$$

An example of the solution of an A.C. circuit at radio frequency will further illustrate the ease with which A.C. circuits are solved by means of complex notation. The circuit is shown in Fig. 12. The reactances are calculated in the usual manner.

$$X_L = 2\pi FL = 6.28 \times 5 \times 10^5 \times 10^{-4} = 314 \text{ ohms}$$

$$X_C = 1/2\pi FC = \frac{1}{6.28 \times 5 \times 10^5 \times 10^{-9}} = 318 \text{ ohms}$$

$$Z_1 = 10 + j314 = 314.1 \angle 88.2^\circ$$

$$Z_2 = 15 - j318 = 318.7 \angle -87.3^\circ$$

$$Z_1 + Z_2 = 10 + j314 + 15 - j318$$

$$= 25 - j4 = 25.35 \angle -9.1^\circ$$

$$Z = \frac{Z_1 Z_2}{Z_1 + Z_2} =$$

$$\frac{314.1 \angle 88.2^\circ \cdot 318.7 \angle -87.3^\circ}{25.35 \angle -9.1^\circ}$$

$$= 3940 \angle 10^\circ = 3895 + j686 \text{ ohms.}$$

The circuit is seen to be inductive by the positive angle in the polar form or from the positive sign of the reactance in the rectangular form. The equivalent series circuit is a resistance of 3895 ohms and an inductive reactance of 686 ohms, or at 500 Kc/s a 218 μ H coil.

By the admittance method

$$Y_L = \frac{1}{Z_L} = \frac{1}{10 + j314} = .00101 - j.00318 \text{ mho.}$$

$$Y_c = \frac{1}{Z_c} = \frac{1}{15 - j318} = .000148 + j.00314 \text{ mho.}$$

$$Y = Y_L + Y_c = .000249 - j.00004 \text{ mho.}$$

$$Z = \frac{1}{Y} = \frac{1}{.000249 - j.00004} = 3890 + j688 \text{ ohms.}$$

The result is a close check on the first method. Calculations made

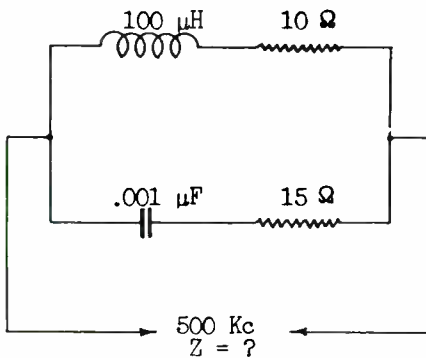

Fig. 12.—Series parallel impedance network.

on the slide rule may not check as closely as those above unless great care is exercised in making each reading.

SOME GENERAL APPLICATIONS OF COMPLEX NOTATION

LCR NETWORKS.—The following discussion will give the student

some idea of the usefulness of complex notation in solving some of the more common applications of alternating current circuits. Most complicated networks can be reduced to reasonably simple equivalent circuits which are easily solved by means of complex algebra.

Frequently it is necessary to transform impedances in such manner that a minimum of power is lost in the transformation. A resistance network cannot be used because of the power lost in heat in the resistors. A pure reactance consumes no power and is often employed for making a certain resistance appear to be of some value other than its actual magnitude.

For example an antenna is to be operated on such a mode that the impedance at the point of coupling is $120 + j0$ ohms. This antenna is to be excited from an 80 ohm (pure resistance) transmission line. If the transmission line is connected directly to the antenna power will be lost due to the mismatch of impedances. For most efficient power transfer the impedance of the antenna must be matched to that of the transmission line.

To insure minimum power loss in the matching network the matching must be done by using pure reactances. The problem is to 'sink' the antenna impedance so that it presents an impedance of $80 + j0$ ohms to the transmission line. A pure reactance in parallel with the antenna impedance will lower the total impedance. The resulting impedance of the antenna will then be reactive instead of resistive but by connecting a suitable reactance of opposite sign in series with the parallel combination the network can be brought back to resonance.

For example a 100 ohm resistance is shunted by a $1 \mu\text{F}$ capacitor as shown in Fig. 13. What is the apparent resistance

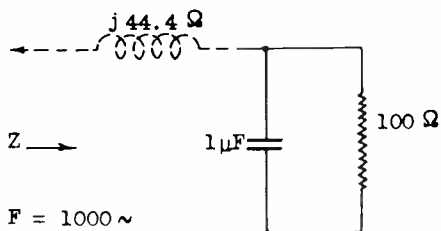

Fig. 13. —Method to obtain a pure resistance impedance by an LCR network.

and capacity at 1000 cycles?

$$X_c = \frac{1}{\omega c} = \frac{1}{6.28 \times 10^3 \times 10^{-6}} = 159 \text{ ohms}$$

$$Z = \frac{Z_1 Z_2}{Z_1 + Z_2} = \frac{100(-j159)}{100 - j159}$$

$$= 71.5 - j44.4 \text{ ohms}$$

The real part 71.5 ohms is the APPARENT resistance and the j part 44.4 ohms is the APPARENT reactance. The original 100 ohms resistance has been transformed to 71.5 ohms while the 159 ohms capacity reactance has been transformed to 44.4 ohms. If an inductance having a reactance of 44.4 ohms at 1000 cycles is connected in series with the parallel combination as shown by the dotted lines in Fig. 13, the capacity reactance will be balanced out and the IMPEDANCE LOOKING INTO THE NETWORK WOULD BE 71.5 OHMS PURE RESISTANCE. This particular principle has many important applications in radio engineering.

The solution of more complex circuits is greatly simplified by complex notation as illustrated in the following example. Refer to Fig. 14.

$$Z_1 = 8.66 + j5 = 10 \angle 30^\circ$$

$$Z_2 = 7.07 - j7.07 = 10 \angle -45^\circ$$

$$Z_1 + Z_2 = 15.73 - j2.07$$

$$= 15.86 \angle -7.5^\circ$$

$$Z_p = \frac{10 \angle 30^\circ \cdot 10 \angle -45^\circ}{15.86 \angle -7.5^\circ}$$

$$= 6.3 \angle -7.5^\circ$$

Converting Z_p to the rectangular form,

$$Z_p = 6.3(\text{Cos } 7.5^\circ - j \text{Sin } 7.5^\circ)$$

$$= 6.25 - j.82 \text{ ohms}$$

Since Z_p is in series with Z_3 the total impedance is found by addition

It must be understood that Z_1 , Z_2 , and Z_3 are the expressions for the impedances IN THE COMPLEX FORM.

Substituting the complex ex-

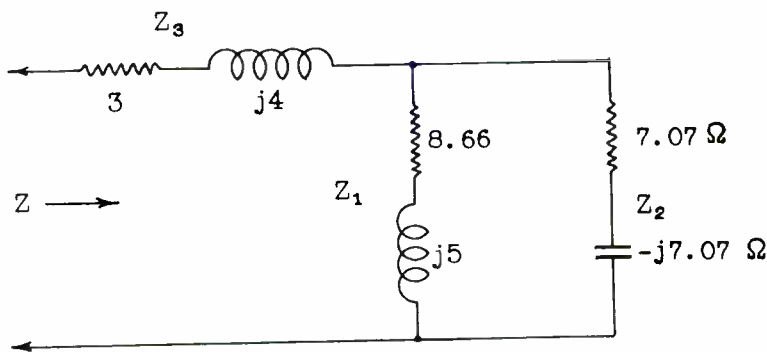

Fig. 14.—Using complex notation for solving the impedance of a complex circuit.

$$Z = Z_p + Z_3 = 6.25 - j.82 + 3 + j4$$

$$= 9.25 + j3.18 \text{ ohms.}$$

Thus the circuit of Fig. 14 is equivalent to an inductive reactance of 3.18 ohms in series with 9.25 ohms resistance. Conversion to the polar form gives the absolute magnitude of the impedance and the angle by which it affects the current and voltage.

$$9.25 + j3.18 = 9.78 \angle 19.0^\circ$$

The angle is positive and I will lag E by 19° .

One of the most important applications of complex notation is in the development of analytical expressions for circuit behavior. Fig. 15 shows an impedance Z_1 in series with Z_2 and Z_3 in parallel. It is apparent that

$$Z = Z_1 + \frac{Z_2 Z_3}{Z_2 + Z_3}$$

pressions for Z_1 , Z_2 , and Z_3

$$Z = R_1 + jX_1 +$$

$$\frac{(R_2 + jX_2)(R_3 + jX_3)}{(R_2 + jX_2) + (R_3 + jX_3)}$$

Simplify

$$Z = R_1 + jX_1 +$$

$$\frac{R_2 R_3 - X_2 X_3 + j(R_3 X_2 + R_2 X_3)}{(R_2 + R_3) + j(X_2 + X_3)}$$

In the above expression the actual sign of the j term depends on whether X is inductive or capacitive. The form $R + jX$ is used for greater simplicity, the sign of the j term being changed to suit the numerical values substituted in the formula.

The formula as derived is a general expression for the impedance of any A.C. circuit equivalent to that shown in Fig. 15. The ease with which the impedances Z_1 , Z_2 , and Z_3 are handled algebraically

indicates the simplicity of analytic solutions when complex notation is used.

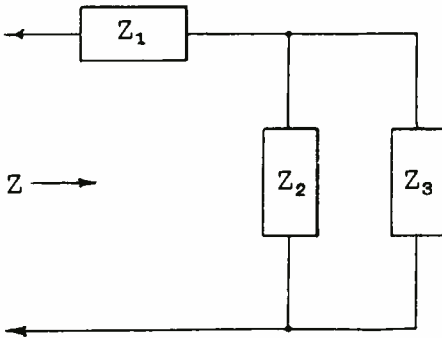

Fig. 15. — Impedances in the complex form.

A second illustration is furnished by Fig. 16. The impedance looking into the circuit is

$$Z = Z_1 + \frac{Z_2 (Z_3 + Z_4)}{Z_2 + Z_3 + Z_4}$$

The circuit shown in Fig. 16

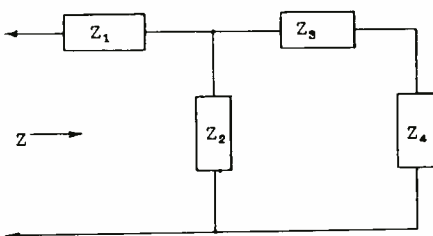

Fig. 16. — Impedances in the complex form forming a T network.

will be recognized as a T network often used to couple a generator to a load. Fig. 17 shows the same type of circuit with numerical values assigned to the circuit components. At an operating frequency of 1000 kc/s:

$$Z_1 = jX_1 = j(6.28 \times 10^6 \times 43.4 \times 10^{-6}) = j273 \text{ ohms}$$

$$Z_2 = -jX_2 = \frac{1}{-j(6.28 \times 10^6 \times 355 \times 10^{-12})} = -j448 \text{ ohms}$$

$$Z_3 = -jX_3 = -j\left(\frac{1}{6.28 \times 10^6 \times 38 \times 10^{-11}}\right) = -j418 \text{ ohms}$$

$$Z_4 = 500 + j0 \text{ ohms.}$$

$$Z = j273 + \frac{-j448 (500 - j418)}{500 - j448 - j418}$$

$$= j273 + \frac{-j448 (500 - j418)}{500 - j866}$$

Converting to polar form for multiplication and division

$$-j448 = 448 \angle -90^\circ$$

$$500 - j418 = 654 \angle -39.95^\circ$$

$$500 - j866 = 1000 \angle -60^\circ$$

The impedance for the parallel part of the circuit is —

$$Z_p = \frac{448 \angle -90^\circ \cdot 654 \angle -39.95^\circ}{1000 \angle -60^\circ}$$

$$= 293 \angle -69.95^\circ$$

$$= 100 - j273 \text{ ohms.}$$

The total impedance

$$Z_1 + Z_p = j273 + 100 - j273$$

$$= 100 \text{ ohms.}$$

The impedance looking into the circuit is a pure resistance of 100 ohms. The circuit of Fig. 17 could be used to match a 100 ohm

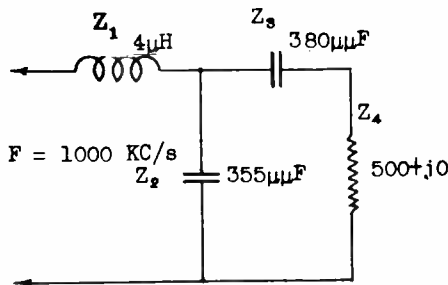

Fig. 17. — Circuit components with numerical values.

generator to a 500 ohm load at an operating frequency of 1000 Kc/s with practically zero power loss. This assumes the reactances used in the network are designed for very low loss.

DESIGN OF T-NETWORKS. — Fig. 18 shows the equivalent circuit of a typical T network used to match a generator to a load. Z_p , the internal impedance of the generator, and Z_L , the impedance of the load, are usually pure resistances. Z_1 , Z_2 , and Z_3 are usually low loss reactances and

for most calculations may be considered as pure reactances. If—

$$Z_p = R_1$$

$$Z_L = R_2$$

$$Z_1 = X_1$$

$$Z_2 = X_2$$

$$Z_3 = X_3$$

then the impedance looking from the generator toward the load is—

$$R_1 = X_1 + \frac{(X_2 + R_2) X_3}{X_2 + X_3 + R_2}$$

Multiplying by $X_2 + X_3 + R_2$

$$R_1 (X_2 + X_3) + R_1 R_2 =$$

$$X_1 X_2 + X_1 X_3 + X_1 R_2 + X_2 X_3 + R_2 X_3 \quad (1)$$

The impedance looking from the load toward the generator is

$$R_2 = X_2 + \frac{(X_1 + R_1) X_3}{X_1 + X_3 + R_1}$$

Multiplying by $X_1 + X_3 + R_1$

$$R_2 (X_1 + X_3) + R_1 R_2 =$$

$$X_1 X_2 + X_2 X_3 + X_2 R_1 + X_1 X_3 + R_1 X_3 \quad (2)$$

Subtract (2) from (1)

$$R_1 (X_2 + X_3) - R_2 (X_1 + X_3) =$$

$$X_1 R_2 + R_2 X_3 - X_2 R_1 - R_1 X_3$$

Collecting terms

direct substitution of reactance magnitudes:

$$R_1 (X_2 + X_3) - R_2 (X_1 + X_3) =$$

$$R_2 (X_1 + X_3) - R_1 (X_2 + X_3)$$

$$R_1 R_2 = -(X_1 X_2 + X_1 X_3 + X_2 X_3) \quad (5)$$

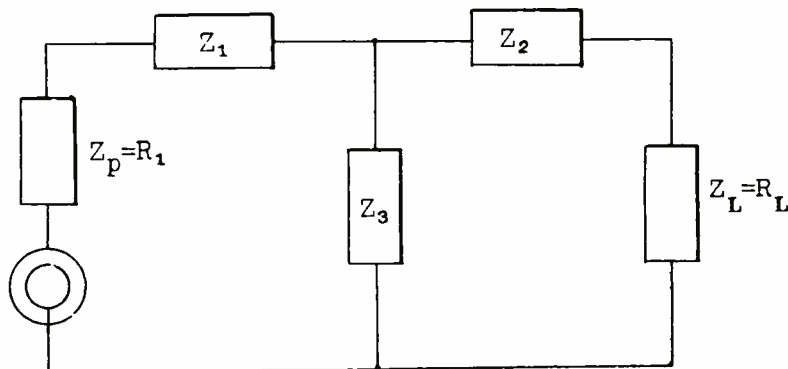

Fig. 18. — Impedances forming a T Network.

Transposing

$$R_1 (X_2 + X_3) + R_1 (X_2 + X_3) =$$

$$R_2 (X_1 + X_3) + R_2 (X_1 + X_3)$$

$$2R_1 (X_2 + X_3) = 2R_2 (X_1 + X_3)$$

Dividing by $2R_2 (X_2 + X_3)$

$$\frac{R_1}{R_2} = \frac{X_1 + X_3}{X_2 + X_3} \quad (3)$$

Adding equations 1 and 2

$$2R_1 R_2 = 2X_1 X_2 + 2X_1 X_3 + 2X_2 X_3$$

$$R_1 R_2 = X_1 X_2 + X_1 X_3 + X_2 X_3 \quad (4)$$

Equation (4) would require the substitution of reactance values in complex form, (i.e. jX_1, jX_2 , etc.) Since $j^2 = -1$, the equation may be altered as follows to permit the

By means of equations 3 and 5 it is possible to match two impedances by means of a T network by assuming a value for any one reactance and solving for the other two. As will be shown in a later assignment, if X_1, X_2 , and X_3 are made pure resistances a T type attenuation pad results. By selecting the proper resistance values a definite amount of attenuation can be obtained with the impedance match.

To illustrate the design of a T network assume it is desired to match a 300 ohm generator to a 600 ohm load at 1000 Kc/s. The circuit is shown in Fig. 19. X_3 is assumed to be 800 ohms capacitive reactance. In making this assumption care must be exercised that X_3 is not made too low otherwise the load will be transformed to a value below that of the generator and X_2 would change from an inductive to a capacitive

reactance. If the network is to handle any great amount of power X_3 is usually a fixed capacity, X_1 and X_2 being inductances adjustable by taps. Properly adjusted the impedance facing the load terminals will measure 600 ohms and facing the generator or source 300 ohms both being pure resistances.

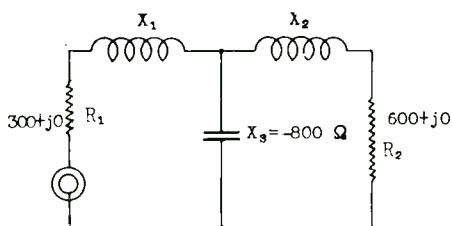

Fig. 19. — Matching impedances by a T network so the resulting impedance will be resistive.

It is evident from Fig. 19 that the impedance of X_3 , in parallel with X_2 and R_2 in series, must transform the series impedance of X_2 and R_2 to 300 ohms plus a certain amount of capacity reactance. The reactance of X_1 then will cancel the equivalent series reactance of the parallel combination and leave only the pure resistance facing the power source. The problem is to convert the parallel part of the network facing the load to 300 - jX ohms. X_1 will then be made equal to -jX but opposite in sign. The solution is obtained from equations 3 and 5.

$$\frac{R_1}{R_2} = \frac{X_1 + X_3}{X_2 + X_3}$$

$$\frac{300}{600} = \frac{X_1 + (-800)}{X_2 + (-800)}$$

$$\frac{1}{2} = \frac{X_1 - 800}{X_2 - 800}$$

$$X_2 - 800 = 2X_1 - 1600$$

$$2X_1 = X_2 - 800 + 1600$$

$$X_1 = .5X_2 + 400$$

$$R_1 R_2 = -(X_1 X_2 + X_1 X_3 + X_2 X_3)$$

$$300 \times 600 = - [(.5X_2 + 400) X_2 + (.5X_2 + 400)(-800) + X_2(-800)]$$

$$180,000 = -(.5X_2^2 + 400X_2 - 400X_2 - 320,000 - 800X_2)$$

$$180,000 = -(.5X_2^2 - 800X_2 - 320,000)$$

$$180,000 = -.5X_2^2 + 800X_2 + 320,000$$

$$.5X_2^2 - 800X_2 - 320,000 + 180,000 = 0$$

$$.5X_2^2 - 800X_2 - 140,000 = 0$$

Multiplying by 2

$$X_2^2 - 1600X_2 - 280,000 = 0$$

This is a quadratic equation which may be solved by the quadratic formula

$$X_2 = \frac{-b \pm \sqrt{b^2 - 4ac}}{2a} = \frac{+1600 \pm \sqrt{1600^2 - 4(1)(-280000)}}{2(1)}$$

$$X_2 = +1759 \text{ or } -159$$

The equation may also be solved by factoring:

$$(X_2 - 1759)(X_2 + 159) =$$

$$X_2^2 - 1600X_2 - 280,000$$

$$(X_2 - 1759)(X_2 + 159) = 0$$

If

$$X_2 - 1759 = 0, X_2 = 1759$$

If

$$X_2 + 159 = 0, X_2 = -159$$

The negative value for X_2 may be discarded since X_2 is known to be positive.

If

$$X_2 = 1759 \text{ ohms and } X_1 = .5X_2 + 400$$

then

$$X_1 = (.5 \times 1759) + 400 = 1279.5 \text{ ohms}$$

Summarizing

$$\begin{aligned} R_1 &= 300 \text{ ohms} \\ R_2 &= 600 \text{ ohms} \\ X_1 &= 1279.5 \text{ ohms} \\ X_2 &= 1759 \text{ ohms} \\ X_3 &= -800 \text{ ohms} \end{aligned}$$

At 1000 Kc/s

$$C = \frac{1}{\omega X_c} = \frac{1}{6.28 \times 10^6 \times 8 \times 10^2} = .0002 \mu\text{F}$$

$$L_1 = \frac{X_1}{\omega} = \frac{1279.5}{6.28 \times 10^6} = 204 \mu\text{H}$$

$$L_2 = \frac{1759}{6.28 \times 10^6} = 280 \mu\text{H}$$

The impedance facing the source is

$$R_1 = j1279.5 + \frac{-j800(600 + j1759)}{600 + j1759 - j800}$$

$$R_1 = j1279.5 + \frac{141 \times 10^4 - j48 \times 10^4}{600 + j959}$$

$$= j1279.5 + \frac{147 \times 10^4 \angle -18.8^\circ}{1130 \angle 58^\circ}$$

$$= j1279.5 + 1301 \angle -76.8^\circ$$

$$= j1279.5 + 297 - j1266$$

$$= 297 + j13.5$$

This is very close to 300 ohms pure resistance.

Similarly it can be shown that

$$R_2 = jX_2 + \frac{-jX_3(R_1 + jX_1)}{R_1 + jX_1 - jX_3}$$

THE π NETWORK.—The π network is frequently used to couple a transmitter to an antenna. Among amateurs this circuit is frequently referred to as a Collin's coupler. Properly designed the circuit has excellent harmonic suppression qualities. The circuit is shown in Fig. 20. When Z_2 is inductive and Z_1 and Z_3 capacitive the circuit is essentially a low pass filter. The network is designed to cutoff just above the fundamental frequency. The general expression for the impedance looking into the circuit is

$$Z = \frac{Z_1(Z_2 + \frac{Z_3 Z_4}{Z_3 + Z_4})}{Z_1 + Z_2 + \frac{Z_3 Z_4}{Z_3 + Z_4}}$$

The various impedances may be partly resistive and partly reactive or wholly resistive or wholly reactive.

DESIGN OF A π NETWORK.—If in Fig. 20.

$$Z = R_1$$

$$Z_4 = R_2$$

$Z_1 = X_1$ (capacitive reactance)

$Z_2 = X_2$ (inductive reactance)

$Z_3 = X_3$ (capacitive reactance)

3 and 4. If sufficient coupling is to be obtained X_2 must not exceed $\sqrt{R_1 R_2}$.

Assume it is desired to couple an 1800 ohm generator to a 300 ohm

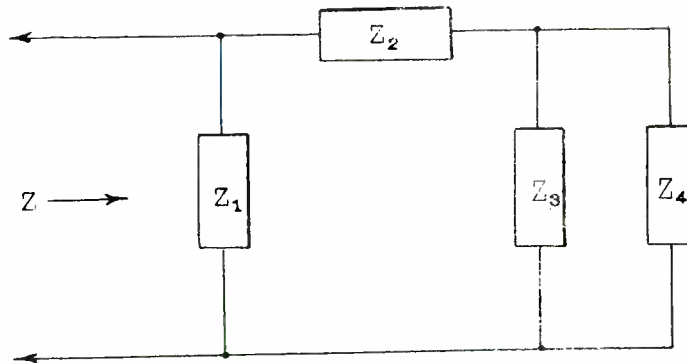

Fig. 20.—A π network used to couple a transmitter to an antenna.

It can be shown that the following equations are true

$$R_1 R_2 = \frac{-X_1 X_2 X_3}{X_1 + X_2 + X_3} \quad (1)$$

$$\frac{R_1}{R_2} = \frac{X_1 (X_2 + X_3)}{X_3 (X_1 + X_2)} \quad (2)$$

As in the T network one of the reactances must be opposite in sign to the other two so that the terminating impedances will be pure resistances.

It can also be shown that

$$X_3 = \frac{-R_2 X_2}{R_2 + \sqrt{R_1 R_2 - X_2^2}} \quad (3)$$

$$X_1 = \frac{-R_1 X_2}{R_1 + \sqrt{R_1 R_2 - X_2^2}} \quad (4)$$

In designing the π network X_2 is usually arbitrarily selected and X_1 and X_3 calculated from Equations

line.

$$\sqrt{R_1 R_2} = \sqrt{1800 \times 300} = 735$$

X_2 must not exceed 735 ohms. Assume a value of 650 ohms. Then

$$X_3 = \frac{-300 \times 650}{300 + \sqrt{(300 \times 1800) - 650^2}} =$$

$$\frac{-195 \times 10^3}{643}$$

$$= -303 \text{ ohms}$$

$$X_1 = \frac{-1800 \times 650}{1800 + \sqrt{(300 \times 1800) - 650^2}} =$$

$$\frac{-117 \times 10^4}{2143}$$

$$X_1 = -546 \text{ ohms}$$

The complete circuit is shown in Fig. 21.

If the circuit is designed on the basis of the minus sign preceding the radical in Equations 3 and 4,

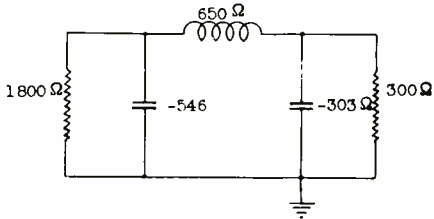

Fig. 21. — A π network for harmonic suppression.

then

$$X_3 = \frac{-195 \times 10^3}{300 - \sqrt{(300 \times 1800) - 650^2}} = \frac{-195 \times 10^3}{-43} = +4535 \text{ ohms (} X_3 \text{ must be an inductance)}$$

$$X_1 = \frac{117 \times 10^4}{1800 - 343} = \frac{-117 \times 10^4}{1457} = -803$$

The resulting circuit is shown in Fig. 22. Fig. 21 is the better of the two from the standpoint of harmonic suppression. With the reactances and operating frequency known it is a simple matter to calculate the required values of L and C.

Another example to illustrate the ease of algebraic manipulation for the complex quantity is in the determination of the impedance looking into a network involving coupling. Fig. 23 shows the schematic circuit. Z_1 is the impedance of the

generator (R_p of the tube), Z_2 the impedance of the primary, Z_3 the impedance of the secondary, and Z_4 the impedance coupling the two meshes together, and which is due to the mutual inductance of the two coils.

In Fig. 23, current I_1 in flowing through Z_2 produces a back e. m. f. in that impedance of value $I_1 Z_2$, but at the same time it induces a voltage in mesh 2 of value $I_1 Z_4$, where Z_4 is the transfer or mutual effect, mentioned above, and which specifies how much voltage is induced in one mesh due to a current flow in the other. The voltage induced in mesh 2 causes a current I_2 to flow in that mesh. This current in turn induces through the agency of Z_4 a voltage in mesh 1 which is of a direction opposite to $I_1 Z_2$, and hence is a voltage rise in that mesh. Thus the voltage

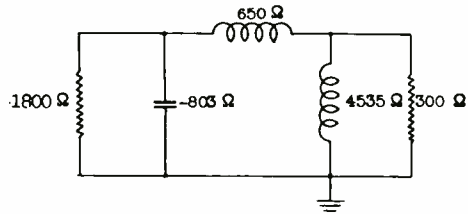

Fig. 22. — A resulting circuit of a π network.

drops in either mesh are the result of currents in both meshes, because of the coupling between the two meshes. The equation of current flow for each mesh can be written as follows:

$$\text{Mesh 1. } E = I_1 Z_1 + I_1 Z_2 - I_2 Z_4 \quad (1)$$

$$\text{Mesh 2. } 0 = -I_1 Z_4 + I_2 Z_3 \quad (2)$$

Note that in Mesh 1 the voltage

drops (and rises) must total to the impressed voltage E , whereas in Mesh 2 the sum of the voltage drops must equal zero, since no voltage is directly impressed in this mesh.

Transposing $-I_1 Z_4$ in Equation (2) and solving for I_2 by dividing

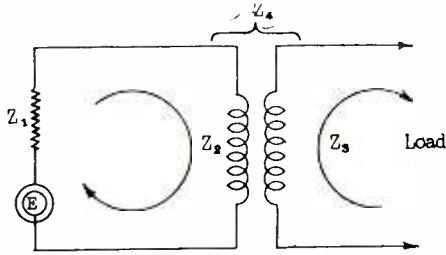

Fig. 23. — A schematic circuit.

both members by Z_3

$$I_1 Z_4 = I_2 Z_3$$

$$I_2 = I_1 \frac{Z_4}{Z_3} \quad (3)$$

The value of I_2 can now be substituted from (3) in (1). Thus,

$$E = I_1 Z_1 + I_1 Z_2 - I_1 \frac{Z_4^2}{Z_3} \quad (4)$$

Essentially, Equations (1) and (2) have been solved simultaneously for I in terms of E , Z_1 , Z_2 , Z_3 and Z_4 , the solution being obtainable from equation (4) in one step. However, interest at this time is not centered upon obtaining the value I_1 , but rather upon determining the impedance of the primary circuit

with the secondary reacting on it. This impedance is clearly E/I_1 and can be found by dividing both members of Equation (4) by I_1 . The result is:

$$\frac{E}{I_1} = Z_1 + Z_2 - \frac{Z_4^2}{Z_3} \quad (5)$$

Call the primary impedance Z_p . If there were no coupling between the primary and secondary ($Z_4 = 0$) then Z_p would be simply $Z_1 + Z_2$. But if there is coupling, then Z_p is changed from the above value to

$$Z_1 + Z_2 - \frac{Z_4^2}{Z_3}$$

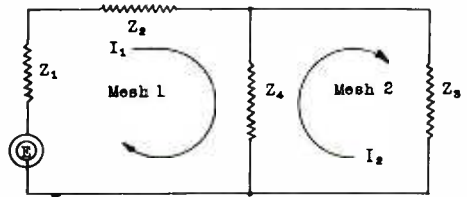

Fig. 24. —Equivalent circuit composed of a resistive mesh.

The additional term,

$$- \frac{Z_4^2}{Z_3}$$

is called the REFLECTED IMPEDANCE.

ANSWERS TO EXERCISE PROBLEMS

- | | | |
|---|---|--|
| 1. $37.2 \angle 126^\circ$ | 2. $50.2 \angle -84.3^\circ$ | 3. $.065 \angle -22.6^\circ$ |
| 4. $1155 \angle 49.2^\circ$ | 5. $10 \angle 217^\circ$ | 6. $3.16 \angle 252^\circ$ |
| 7. $5.83 \angle -59^\circ$ | 8. $13.5 \angle -48^\circ$ | 9. $40 \angle 90^\circ$ |
| 10. $32 \angle 180^\circ$ | 11. $50 \angle 30^\circ$ | 12. $10 \angle -75^\circ$ |
| 13. $E = 100 \angle -15^\circ$
$I = 21 \angle 6^\circ$ | 14. $98 \angle -90^\circ$ | 15. $37.5 \angle 48.2^\circ$ |
| 16. $6.93 + j4$ | 17. $50 + j80$ | 18. $186 \times 10^5 + j235 \times 10^5$ |
| 19. $-411 - j158$ | 20. $-205 - j78.8$ | 21. $8.86 - j11.6$ |
| 22. $-61.5 - j98.4$ | 23. $101 + j44.4$ | 24. $-.006 + j0$ |
| 25. $0 - j90$ | 26. $18.7 + j20$ | 27. $48 - j20.7$ |
| 28. $19 - j.16$ | 29. $-.841 - j.817$ | 30. $-7 - j4$ |
| 31. $720 \angle 57^\circ$ | 32. $.00018 \angle -79^\circ$ | 33. $9828 \angle 210^\circ$ |
| 34. $792 \angle 6^\circ$ | 35. $62 \angle 25^\circ$ | 36. $1.25 \angle -17^\circ$ |
| 37. $20 \angle 49^\circ$ | 38. $.404 \angle -160^\circ$ | 39. $1.64 \angle 66^\circ$ |
| 40. $248 \angle -15^\circ$ | | |
| Rectangular | Polar | Exponential |
| 41. $13 + j7.5$ | $15 \angle 30^\circ$ | $15e^{j30^\circ}$ |
| 42. $7.07 + j7.07$ | $10 \angle 45^\circ$ | $10e^{j45^\circ}$ |
| 43. $-100 + j0$ | $100 \angle 180^\circ$ | $100e^{j180^\circ}$ |
| 44. $20 + j34.6$ | $40 \angle 60^\circ$ | $40e^{j60^\circ}$ |
| 45. $3 - j4$ | $5 \angle -53.1^\circ$ | $5e^{-j53.1^\circ}$ |
| 46. $4 + j3$ | $5 \angle 36.8^\circ$ | $5e^{j36.8^\circ}$ |
| 47. $8.5 - j8.5$ | $12 \angle -45^\circ$ | $12e^{-j45^\circ}$ |
| 48. $12.4 \angle 15^\circ$ | 49. $5.94 \angle -39^\circ$ | 50. $3.87 \angle -17.2^\circ$ |
| 51. $2.24 \angle 53.4^\circ$ | 52. $.136 \angle 12^\circ$ or $/-168^\circ$ | 53. $13 \angle 112.6^\circ$ |
| 54. $64 \angle 102.4^\circ$ | 55. $125000 \angle 90^\circ$ | 56. $49 \angle -100^\circ$ |
| 57. $6561 \angle 108^\circ$ | 58. $31.6 \angle 15^\circ$ | 59. $.397 \angle 6.67^\circ$ |
| 60. $10^4 \angle -80^\circ$ | | |



COMPLEX NOTATION

EXAMINATION

1. (A) Convert to polar form:
 $-8 + j9 = ?$

$$14 - j7 = ?$$

- (B) Convert to rectangular form:
 $27 \angle 88^\circ$

$$50 \angle 210^\circ$$

2. (A) $(49 \angle 34^\circ)(56 \angle -40^\circ) = ?$

(B) $(-6 + j14)(62 \angle 129^\circ) = ?$

COMPLEX NOTATION

EXAMINATION, Page 2.

3. $75 \angle 60^\circ \div 15 \angle -35^\circ = ?$

$$148 \angle 128^\circ \div 22 \angle 316^\circ = ?$$

4. $(9 \angle -15^\circ)^3 = ?$

$$(8 \angle 90^\circ)^{1/3} = ?$$

5. $E = 220 \angle 170^\circ$, $I = 4 \angle 100^\circ$, Find P.

$$E = 20 + j40 \text{ volts, } I = 3 + j6 \text{ amperes. Find P.}$$

COMPLEX NOTATION

EXAMINATION, Page 3

6.

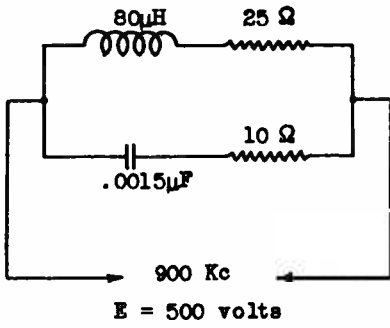

(A) Find Z of circuit.

(B) Calculate power lost in circuit

COMPLEX NOTATION

EXAMINATION, Page 4

7. What is the equivalent series impedance of a 200 ohm resistance shunted by a $.7\mu\text{F}$ capacitor. $F = 1000 \text{ c.p.s.}$

8.

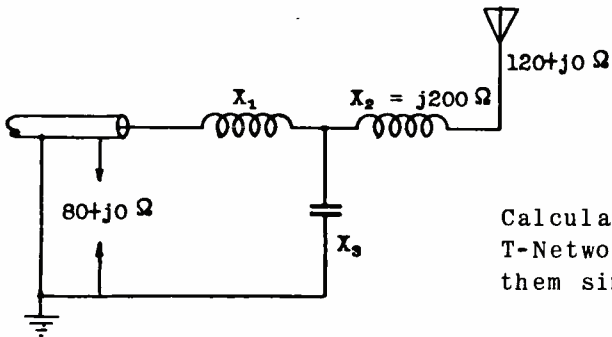

Calculate X_1 and X_3 . Use the T-Network formulas and solve them simultaneously.

COMPLEX NOTATION

EXAMINATION, Page 5.

9.

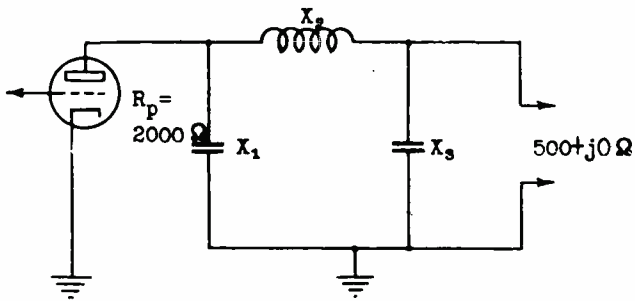

Calculate C_1 and C_3 for 1000 Kc/s when X_2 is 80% of its maximum permissible value.

COMPLEX NOTATION

EXAMINATION, Page 6.

10.

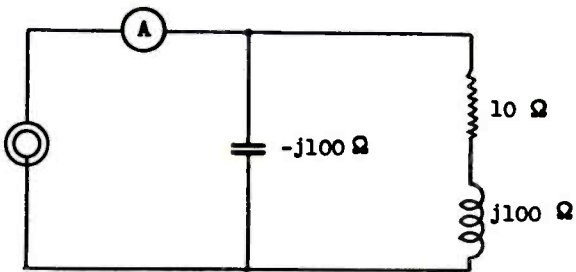

A reads 1 ampere what is the current in each branch of the circuit? Find the input impedance first.

