



SPECIALIZED TELEVISION ENGINEERING

TELEVISION TECHNICAL ASSIGNMENT

THE MECHANISM OF THE EYE

Copyright 1946 by
Capitol Radio Engineering Institute
Washington, D. C.

704D

THE MECHANISM OF THE EYE

FOREWORD

It has been aptly observed that if Alexander Graham Bell had been aware of the complex nature of sound, and of the involved mechanism of hearing, he would have been discouraged in attempting to invent the telephone. One might think that lack of knowledge, or at least of knowledge of the difficulties that beset the path of the inventor, is desirable, and a detailed study of a subject is more harmful than good.

On the other hand, if the thousands of would-be inventors of a perpetual motion machine were better conversant with the principles of physics, particularly with the principle of the conservation of energy, they would divert their efforts to a more fruitful line of endeavor.

Be that as it may, we are confronted in television not with an idea or a wish, but with a practical system. Possibly a radically different system of television will be invented, but the chances are better that worthwhile improvements will be made on the present arrangement.

It is therefore necessary to understand the difficulties that have already been encountered by inventors in the past, in order to appreciate how these obstacles were circumvented, and how certain facts were made to work for, rather than against the system in use today.

Among these facts are the characteristics of the human eye. It requires no argument to support the statement that any successful and practical television system *must* be designed to fit the characteristics of the eye, and that the latter has a profound effect upon the design and operation of the television equipment.

This assignment therefore chooses as its subject the eye and its relation to television. Many students may be itching to get on to the assignments that deal with video amplifiers, transmitter design, pulse techniques, and the

THE MECHANISM OF THE EYE

like, but after reading in the following pages how the eye determines the frame repetition rate, the band width of the television channel, interlacing, and brightness effects, they will undoubtedly agree that it is not only important to study these fundamental facts, but also absorbingly interesting.

Applied theory is never dull, and it produces a background that permits the student to study further details from a more mature viewpoint.

E. H. Rietzke,
President.

TABLE OF CONTENTS

THE MECHANISM OF THE EYE

	Page
THE EYE	1
<i>ESSENTIAL COMPONENTS OF THE EYE.</i>	<i>2</i>
<i>OPTICAL CHARACTERISTICS.</i>	<i>3</i>
STANDARDS FOR A TELEVISION SYSTEM.	4
<i>ANGLE OF RESOLUTION.</i>	<i>4</i>
<i>DIFFRACTION EFFECTS.</i>	<i>6</i>
<i>ANGLE OF VIEW.</i>	<i>8</i>
<i>NUMBER OF LINE ELEMENTS.</i>	<i>9</i>
<i>ASPECT RATIO</i>	<i>10</i>
<i>BAND WIDTH REQUIREMENTS.</i>	<i>12</i>
PRINCIPLES OF SCANNING.	16
<i>FLICKER FREQUENCY.</i>	<i>16</i>
<i>Persistence Of Vision</i>	<i>16</i>
<i>THE STROBOSCOPE.</i>	<i>17</i>
<i>ILLUSION OF MOTION</i>	<i>17</i>
<i>Motion Pictures</i>	<i>18</i>
<i>For The Same Speed Of The Film.</i>	<i>19</i>
<i>Elimination of Flicker.</i>	<i>19</i>
<i>INTERLACED SCANNING.</i>	<i>20</i>
<i>PRACTICAL METHOD OF INTERLACING.</i>	<i>21</i>
<i>BRIGHTNESS AND CONTRAST.</i>	<i>29</i>
<i>PRACTICAL IMPLICATIONS</i>	<i>30</i>
CONCLUSIONS	35

TECHNICAL ASSIGNMENT

TELEVISION IN RELATION TO THE EYE

In a previous assignment it was shown how a practical system of television depends upon one property of seeing, namely, persistence of vision. Briefly, the process starts with a surface that varies in light intensity from point to point at any and all moments of time. This is converted by a scanning process into a series of electrical variations that vary *sequentially with time*. At the receiving end this time variation is reconverted by a similar scanning process into a surface variation, but, unlike the original surface variation, here the areas light up not simultaneously, but still in a time sequence as the beam proceeds from one point of the surface to the next. However, owing to the phenomenon of persistence of vision, the observer thinks that he is seeing all parts of the picture simultaneously. Were it not for this fact, or else persistence of fluorescence of the screen, television would require individual channels between each area of the viewed scene and of the reproduced scene so that all parts of the latter could be properly illuminated *at once* instead of in rapid sequence; in short, television would not be practicable.

Persistence of vision, is however, but one fortunate characteristic of seeing that enables television to function. Other characteristics, such as the ability of the eye to distinguish detail (visual acuity), and its ability to distinguish differences in brightness, color, flicker, etc., all have a profound effect upon the design and operation of the

television system. It is therefore prudent to defer the discussion and analysis of the actual system until these properties have been investigated, for with such a background we shall be better able to understand and appreciate the functioning of the system.

THE EYE

We begin with a study of the eye. This is shown in cross section in Fig. 1. It is approximately globular in shape, about one inch in diameter. Its outer covering, the sclera, S, has six muscles that hold it in place, of which two are shown as A, A, in Fig. 1. The front of the eye has a transparent membrane C, called the cornea, instead of the white membrane, the sclera, and it is through the cornea that the light passes. It continues through a weak salt solution known as the aqueous humor, AH, thence through the crystalline lens L, the vitreous humor VH, and finally falls on the retina R.

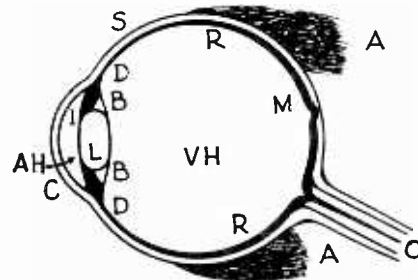

Fig. 1.--Cross section of the eye.

ESSENTIAL COMPONENTS OF THE EYE.—The lens is a capsule containing a fibrous jelly that is hard at the center but becomes softer towards the edges, thus allowing the lens to change its shape and hence the focus of the eye. A ligament B holds the lens in place, and the ciliary muscle D, when tensed, causes the lens to assume a more nearly spherical shape. This in turn decreases the focal length of the eye and enables near objects to be focused on the retina R. When D is relaxed, the lens L is flatter in shape, the focal length is increased, and as a result far objects are focused on the retina.

The vitreous humor is a thin jelly composed mainly of water. The retina R is a delicate covering of nerve fibres that branch out from the optic nerve O and form a kind of spherical screen on the interior of the eyeball. The nerve fibres have two kinds of terminations: one is rod-like in shape, the other is shaped like a cone. They are bathed in a bluish liquid known as visual purple. This appears to be bleached white by the light, and is constantly being regenerated in cells within the eye. A deficiency in vitamin "A" impairs the production of this essential fluid and this in turn prevents the rapid accommodation of the eye to sudden transitions from light to dark. It may be recalled that night-flying aviators were tested for this requirement.

The depression M, called the macula lutea or yellow spot in the retina, is about 2 mm in diameter, and contains mainly cones. The central portion, called the fovea centralis, and about 0.25 mm in

diameter, contains cones exclusively, and here these vary in size from 0.0015 mm to about 0.0054 mm in diameter. On the other hand, the outer regions of the retina contain ten rods to each cone, and the latter are much larger than those at the fovea centralis.

The significance of the above distribution is that the sharpest vision is at the fovea, and the rest of the retina serves mainly to give a general idea or view of the scene, and also to warn of an approaching object from the side. When we examine an object, we focus our attention on successive small portions of it. This means that the muscles rotate the eye until one portion or another is imaged on the fovea, and in viewing a large scene the eye roams continuously over the field of view.

OPTICAL CHARACTERISTICS.—The index of refraction of the interior of the eye is pretty nearly uniform except for the lens, so that very little refraction (bending) of the light occurs within the eyeball. Most of the bending and hence focusing of the light occurs at the external surface of the cornea. The eyeball thus acts as a very thick lens, with the screen (retina) located on the rear surface of the lens. This is quite different from the ordinary type of lens, such as is used in a camera.

Another striking difference is the method of focusing. In a camera the lens is moved toward or away from the film depending upon the distance of the object from the camera. In this way the image is made to appear sharp and distinct on the film, although this refers only to one object plane or dis-

tance. In the case of the eye such method of adjustment is not practical, or at any rate is not the method adopted by nature. Instead, the lens capsule within the eyeball is made to bulge more or less, as described previously, and thus alters somewhat the overall refractive index and hence the *focal length* of the lens. At all times, however, the image distance to the retina, if one can define this quantity uniquely in the case of the eye, is constant. Hence, by varying the *focal length* of the lens rather than the image distance, distant or near objects can be focused sharply on the retina.

This property is called the *accommodation* of the eye. The maximum object distance is practi-

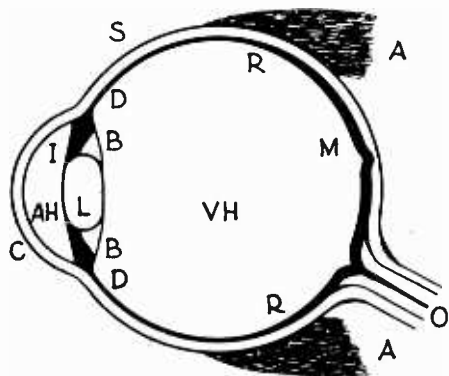

Fig. 1.--Cross section of the eye.

cally infinity; witness the fact that distant stars, if they emit sufficient light, can be seen. The shortest object distance for the normal eye is 10 inches; the lens cannot bulge any more than to accommodate this distance. With

advancing years the lens becomes less flexible and cannot bulge as much, whereupon the minimum object distance becomes greater than the above 10 inches, and the person is said to be far-sighted. Many children can focus on objects much closer than 10 inches; however, this represents an average value for the normal eye, and is considered the normal reading distance.

Another point of interest is that the macula is about 1 mm off the optical axis, as is shown in Fig. 1. This is rather surprising, for in all man-made optical instruments the greatest resolution is obtained on the optical axis. However most precision lenses have far less aberrations (distortions) than the human eye, and produce a relatively sharp and clear image over a greater area of image field than does the eye, in which maximum acuity is obtained only at the fovea,—a very small area.

A final point to note is the action of the iris I, Fig. 1. This is a ring-shaped muscle that involuntarily opens or closes depending upon how weak or bright the incident light is. It acts similar to the iris diaphragm or stop in a camera, and assists the eye in adjusting itself to poorly or brightly illuminated scenes.

The iris can vary its diameter from about 2 mm to 8 mm, which represents an $(8/2)^2 = 16$ -fold variation in area. Thus, light intensities varying over a range of 16 to 1 can be accommodated by the iris, but since this represents but a fraction of the actual range of light intensities encountered

in nature, it is evident that the powers of adjustment of the iris are hardly able to cope with the range of light intensities normally experienced. Instead—as will be shown subsequently—most of the adjustment takes place in the retina itself, and the iris may be looked upon as somewhat analogous to a range-switching device on a meter.

This concludes the discussion of the eye itself. Although much more information concerning its action and construction is available, and far more remains to be discovered, the above elementary description will suffice for the study of television. Further facts will be taken up in conjunction with a study of the basic requirements of television that is to follow. One of the most important of these is the matter of resolution or acuity of vision.

STANDARDS FOR A TELEVISION SYSTEM

The above heading does not refer particularly to the electrical standards, such as channel band width, pulse widths, etc., for the television system, but rather to such standards as are demanded by the eye and the brain of the observer. One of the most important of these is the number of lines or horizontal strips into which the picture must be subdivided in order to obtain a satisfactory or sufficient amount of detail in the reproduced picture. This in turn depends upon the ability of the eye to distinguish fine detail, i.e.,

upon its resolving power (resolution).

This is dependent upon the fact that light is really a wave motion, and tends to spread instead of travel in straight lines, as is popularly believed to be the case. However, the so-called wavelength of light is exceedingly short (around $1/50,000$ of an inch) so that the spreading or bending effect of a ray of light is not ordinarily observed when it passes through an ordinary-sized opening. However, if the opening is small—on the same order of magnitude as a wavelength of light—then the image of an object point of light will not be a point, too, but instead, owing to the tendency of the light to spread or diffract, will appear as a disc of light. In this case, two points of light will appear as two image discs of light. If the object points are close together, the image discs will overlap and appear as a single larger disc of light.

ANGLE OF RESOLUTION.—Everyone is aware of the fact that if he looks at two closely spaced dots, such as those of a colon (:), he can see the two dots more distinctly if he views them from a close distance—say, 10 inches—than if he views them from a greater distance of say, 10 feet. It will also be found that the greater the viewing distance, the farther apart must the dots be in order to be distinguished one from the other. Evidently, then, the ability to distinguish detail in a scene depends upon the separation of the detail *relative* to the distance from which it is viewed.

This is illustrated in Fig. 2. Two points A and B in the scene are viewed by the eye. They are

called object points; the eye produces on the retina two corresponding image points A' and B' ; and it is these image points that the brain really sees. If A and B are sufficiently far apart, then their image points A' and B' will be correspondingly far apart on the retina, and will therefore fall on two different nerve endings or cones in the retina. Two separate impulses will be sent up to the brain, and hence two separate points will be seen.

Suppose, however, that points C and D are viewed. Their image

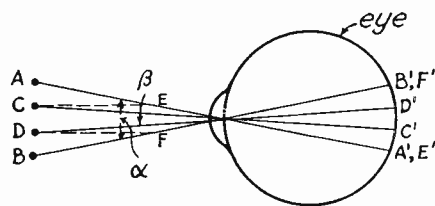

Fig. 2.--Separation of image points on the retina of the eye depends upon the separation and distance of the object points.

points are C' and D' . If C and D are sufficiently close together, then C' and D' may both fall on one nerve ending in the retina. In this case but one impulse is received by the brain; and it "sees" but one point. The eye has failed to perceive the two points C and D ; it has failed to "resolve" this fineness of detail.

On the other hand, if C and D are moved closer to the eye—as indicated by points E and F ,—then even though the separation

is the same as for C and D , nevertheless the image points E' and F' will fall on two nerve endings in the retina just as A' and B' do. They will therefore be resolved as two separate points. Hence, it is not the actual separation of the points that is important, but rather *the ratio of this separation to the distance from the eye*.

This ratio defines mathematically an angle. Thus, points A and B subtend the angle α at the eye, whereas points C and D subtend the smaller angle β . If C and D are moved closer to the eye—represented by E and F ,—then the angle subtended becomes greater. For the closer distance represented by points E and F in Fig. 2, the angle subtended at the eye becomes α also, instead of β .

As a result, in speaking of the ability of the eye to resolve detail, the measure of such ability is the smallest *angle* two such points of detail can subtend at the eye and yet be separately perceived. The resolution varies from one individual to the other, and also depends upon the brightness of the detail, as well as how closely the rods and cones are spaced on the retina. Specifically, it depends upon how closely the cones are spaced in the fovea, for here they have the smallest diameter and can be spaced most closely. The fovea therefore has the greatest resolving power of the eye, and it is here that the greatest acuity of vision occurs.

From the known spacing of the cones, and the diameter of the eye—roughly one inch or 2.54 cm,—the angle of resolution is about

one minute ($1'$) of arc. This is one-sixtieth of a degree, or $1/21,600$ part of a circle, and is a very small angle. Experimentally determined values vary from $2'$ to $0.5'$, and a conservative average value is possibly $1.5'$.

DIFFRACTION EFFECTS.—There is another interesting effect that is a property of light itself, namely diffraction. As will be discussed in later assignments, light is a wave motion of electromagnetic nature in space. One characteristic of a wave motion is its tendency to spread in the medium in which it is travelling. Yet everyone has observed that light appears to travel in straight lines, and objects normally cast shadows, which means that the light does not spread out behind the obstacle and fill that region.

This is illustrated in Fig. 3.

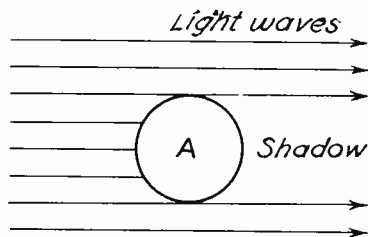

Fig. 3.--Objects ordinarily cast a shadow, which indicates that light travels in straight lines.

The space behind the object A is free of light, none of this energy fills in the space behind the object. Yet if the object is small enough—say, $1/50,000$ th of an inch, it will be found that it cannot cast a shadow; the light will fill in the small space behind it. Whether or not an obstacle can cast a shadow depends

upon its size relative to a wavelength of light; (to be explained more fully in a later assignment) if the obstacle is many times the wavelength of light, a shadow can be formed, if not, no shadow results.

The same effect is noticed in the case of a hole or aperture in an opaque wall illuminated by light. In Fig. 4 is shown such an opaque wall, with two holes, A, and B in it. Hole A is of a fairly

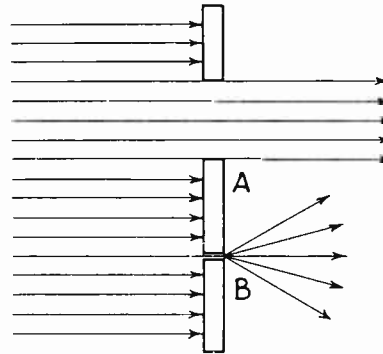

Fig. 4.--Diffraction of light occurs at a small opening.

large size—say, $1/10$ inch or more in diameter; hole B is, say, $.00001$ inch in diameter. A is large compared to a wavelength of light; B is relatively small and comparable to a wavelength of light.

As will be noted from the figure, the light through A proceeds essentially in straight lines in a beam whose diameter is the same as that of A, whereas in B the light rays may be said to curve around and form a diverging beam. This is the phenomenon of dif-

fraction, and is owing to the wave nature of light.

Diffraction produces another effect that is of interest here. Suppose light issues from a point source, and is picked up by a lens, which focuses it into an image point source behind the lens. (The focusing effect of a lens will be discussed in the assignment on optics.) As shown in Fig. 5, P is the point source, L is the lens, and I is the image point.

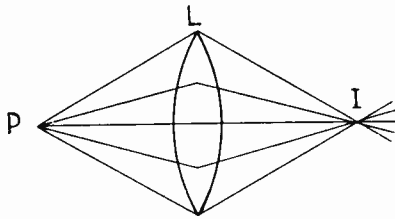

Fig. 5.--Focusing of a point source into an image point.

One would expect, if the lens is perfect, and produces no aberrations (distortions) that I will be a point of light just as P is. However, owing to the wave nature of light, it will not be condensed by the lens into a true geometrical point at I, but into a disc of light of finite diameter.

The diameter of the disc depends upon the diameter of the lens: if the latter is large, the disc diameter is small; if the lens diameter is small, the disc diameter is correspondingly larger. Thus, if a series of object points closely spaced together are to be reproduced as separate image points, it is important that the image points be discs of very small diameter, so that they do not overlap one another, see Fig. 6.

This in turn means that a lens of large diameter is required. A good example is that of an astronomical telescope: the larger its diameter, the better able it is to separate into smaller discrete points of light, two closely spaced stars known as a double-star.



Fig. 6.--Effect of diffraction on detail.

From the above discussion, it is clear that in the case of the eye, even if the cones in the fovea of the retina were spaced an infinitesimal distance apart, so that they could theoretically perceive infinitesimal details in the scene, diffraction would cause a spreading of the image points of light and produce overlapping between adjacent points, and thus limit the detail that could be perceived.

It is interesting to note that for the average opening of 2 mm. for the iris in the eye, two object points that intercept at the eye about 70" of arc, produce image points on the retina that just fail to overlap, and can therefore be perceived separately.

This spacing of 70", which is $70/60 = 1' 10''$, compares almost exactly with the spacing of the cones in the fovea. It indi-

cates that nature has provided the eye with just enough nerve endings in the fovea to take care of the maximum resolution that diffraction will permit. As an interesting corollary, it is to be noted that the eye of an insect cannot distinguish the fineness of detail that the human eye can because the insect's eye is much smaller, so that diffraction is more pronounced and object points appear as larger image discs on the retina of the insect's eye.

In the case of the human eye, for weak light the iris may open to as much as 8 mm. Under these conditions the image discs are smaller, and resolution is limited by the cone spacing rather than diffraction effects. However, the eye is far from being a perfect optical system, and exhibits considerable lens aberrations or distortions, even if the eye is normal. These aberrations are more pronounced at the larger iris openings, and more than counteract the decrease in diffraction effect, so that the eye actually has the greatest resolution at about a 2 mm. iris opening, at which opening resolution is determined almost equally by diffraction effects and the coarseness of the structure of the retina.

ANGLE OF VIEW.—Mention was made that the eye rotated so as to bring all points of interest in the object scene to a focus on the fovea. As an example, try to focus simultaneously on both dots of this colon (:). The angle that they subtend at the normal reading distance of about 10 inches is only about 0.3° , yet if one is focused on the fovea the other is slightly out, off the fovea, the

area of distinct vision. Hence, as stated previously, the eye moves incessantly as one object after another in the scene is examined.

Such movement does not cause any particular fatigue as long as the size of the scene is limited to a value that subtends from about 10° to 20° at the eye. This is called the angle of view. In Fig. 7 the same scene is shown as viewed at various distances by the eye. It is clear from the figure that the angle of view can

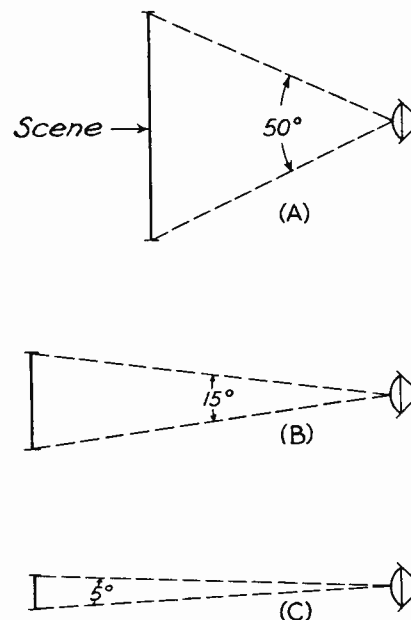

Fig. 7.--By varying the distance between the eye and the scene, the angle of view can be varied over wide limits.

be varied over wide limits— 50° to 5° in Fig. 7.

Everyone has experienced the discomfort of viewing a motion picture scene from a seat in the first few rows in the theatre. Even if the angle of view is not so great as to require the spectator to move his head in order to follow the action on the screen, the need to move the eyes themselves causes fatigue after a short time. (This does not take into account the further discomfort of viewing the scene from an unnatural side angle when one sits at either extreme end of one of the first few rows.)

On the other hand, if one sits too far back in the theatre, the angle of view is small, and the eyes do not have to move about, but then considerable detail is lost, and there may be some straining on the part of the spectator in an attempt to see such detail. Another effect is that the spectator has the impression that he is seeing only part of the entire scene, as if he were looking through a small window. The experience of the motion picture industry is of great value to television, and an average figure of 15° is generally accepted. Of course it must be realized that in such psychological and physiological measurements, considerable variations can occur, and angles of view appreciably greater and less than 15° are still quite acceptable, particularly smaller values.

NUMBER OF LINE ELEMENTS.—The two values given above: $1.5'$ for the angle of resolution, and 15° for the angle of view, permit a simple computation of the number of scanning strips or lines into

which a scene must be divided to furnish an acceptable television picture.

Consider two elements of the picture that are to be resolved (seen as separate elements). Clearly they must occur on separate line strips, as is indicated in Fig. 8, (A) and (B). In (A) are shown two elements, *a* and *b*, that are to be resolved. The dotted lines indicate the two adjacent line strips on which they must be located in order to be separately scanned by the exploring beam. In (B) is shown a side view of the scene and the eye. For the latter to distinguish *a* from *b*, the two elements

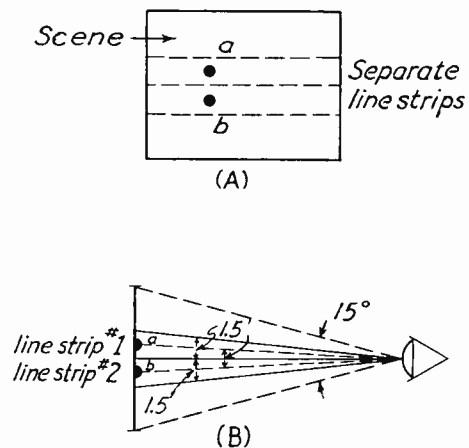

Fig. 8.--Separate elements of detail must be on separate line strips, and these must each subtend 1 minute of arc at the eye.

must subtend one minute of arc, as indicated by the two dotted lines from a and b to the eye.

As is clear from the figure, the two line strips must each therefore individually subtend no more than 1.5' of arc at the eye, as is indicated by the solid lines, in order not to contain both elements a and b in one strip alone. However, the best angle of view is about 15°, or $15 \times 60 = 900'$. Therefore, the total number of line strips into which the picture should be divided is—by simple division —

$$n = 15^\circ \div 1.5' = 900' \div 1.5' \\ = 600 \text{ lines}$$

The number standardized in television is 525 lines, of which 10 per cent occur during the time the exploring beam returns from the bottom to the top after a complete downward vertical scan, and hence do not show. Hence the actual number of lines seen is

$$525 - (525)(.1) = 525 - 52.5 \\ = 472.5$$

or approximately 470 lines.

There are other methods for calculating the number of lines required for a television picture, but the above simple analysis is satisfactory, and indicates the basis for the 525-line picture standard in use today.

ASPECT RATIO.—It was found quite early in the development of the motion picture art that a picture appeared most artistic if it were rectangular instead of square in shape, and so the picture or frame dimensions were made 1 inch wide and 3/4 inch high. This appears to be a satisfactory proportion, namely 4 to 3, and is known as *the aspect ratio*. (See Fig. 9).

With the advent of sound-on-film, about 0.1 inch was taken away from the width of the frames for the sound track (the strip running along the film between the sprocket holes and the frames, on which the sound waves are photographed). This reduced the aspect ratio to a value closer to unity, and was not deemed as artistic a proportion.

A compromise was effected whereby no important dramatic action is permitted to occur near

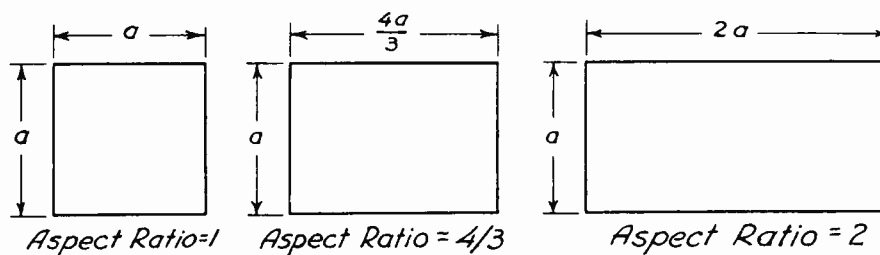

Fig. 9.--Illustration of various aspect ratios

the top or the bottom of the scene, so that the aperture in the motion picture projector through which the film is projected, can be reduced in height to a point where the height is again three-quarters of the (reduced) width. (See Fig. 10.) It is quite common today to

direction as in a vertical direction, or approximately $(4/3)(470) = 627$ squares. The total number of squares or elements in the picture is therefore $627 \times 470 = 295,000$ squares. This compares with the estimate of 300,000 squares given in a previous assignment.

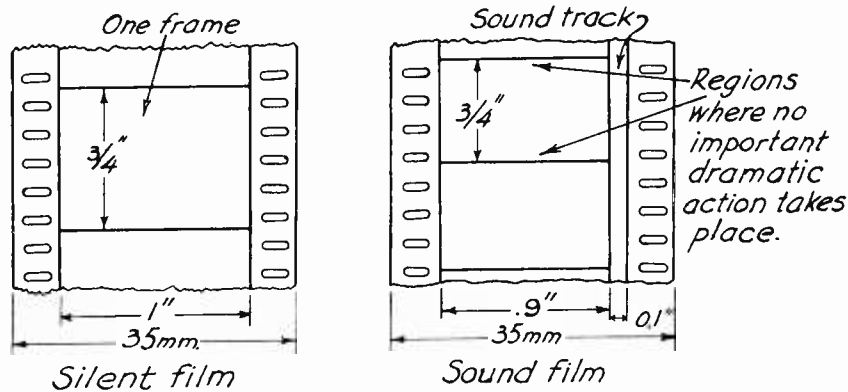

Fig. 10.--Dimensions of silent and sound film.

project film with a slight amount of the top and the bottom of the frames masked off. By slightly increasing the magnification, of the projection lens, the screen image is restored to its initial size.

Since television will depend on film for a great deal of its program material, it is evident that a 4 to 3 aspect ratio would be adopted for the television picture. This in turn affects the number of elements into which the picture is to be subdivided.

It is generally assumed that the same degree of resolution should occur in the horizontal as in the vertical direction, so that the elementary areas will be *squares*. Since the width is $4/3$ the height, this means that there will be $4/3$ as many squares along a horizontal

This analysis should serve to correct a popular misconception regarding resolution versus picture size. The general impression is that the larger the picture, the greater the number of picture elements required. The argument is that if the eye can see detail as small as say, $1/100$ inch, then in a large picture there will be many more areas of one-hundredths of an inch, and hence more elements.

However, in view of the fact that for prolonged and comfortable viewing, the picture or scene should subtend at the eye, and angle no greater than about 15° , and in view of the further fact that two points are resolved on the basis of the angle they subtend at the eye rather than their actual separation in the picture, the maximum number of elements required

is no greater than 600, regardless of the size of the picture.

The significance of this is that when the reproduced picture is magnified, such as by a projection system, it should be viewed from a proportionately greater distance so as to maintain the same viewing angle of 15° , whereupon the same number of elements will suffice as for the smaller picture. This principle has been recognized and employed in sound motion picture work. A large screen is used only in a larger theatre, where even the front row of seats is farther back from the screen than in a small theatre. Anyone who has had occasion to stand close to the screen will have been struck by the blurred picture that he sees, whereas the same picture is perfectly sharp and clear at a greater viewing distance. The optimum viewing angle and distance is illustrated by Fig. 11. Observe that the picture element is smaller for the small screen in order to subtend the same angle of 1.5 minutes.

get too close to a television screen and will perceive the scanning structure. However, it is questionable whether the number of lines and hence band width should be increased because of this possibility, any more than that an artist, in painting a large canvas, should use a fine brush and put in fine detail that can be perceived only upon close viewing.

It is true that in ordinary photographic enlarging, a large positive may be retouched so as to sharpen up the lines and permit closer viewing, particularly if the original was not too sharp to begin with, but in the case of a television picture we shall probably have to be content to view it from the proper distance, although 700 and even 1,000-line pictures have been produced.

BAND WIDTH REQUIREMENTS.—We are now in a position to estimate the frequency band width requirements for a television channel. The method given here is very elementary, and more precise methods

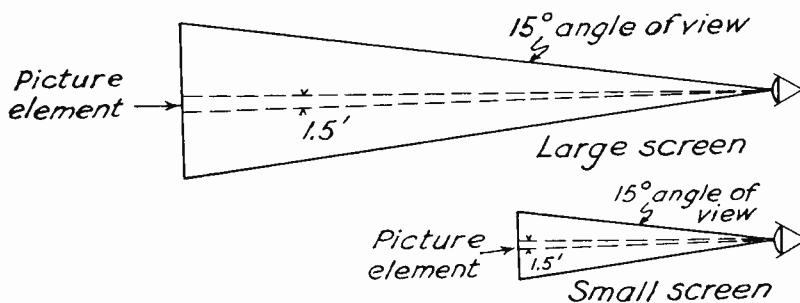

Fig. 11.--A large screen is viewed at a greater distance than a small screen, so that the angle of view is the same in either case.

There is of course always the possibility that the audience will

will be mentioned later. However, the estimate made here is surpris-

ingly close, and is generally satisfactory for design purpose.

First consider a very elementary type of picture imaged in the television camera and shown in Fig. 12. This consists of shading that varies from grey to white to grey to black to grey as one proceeds from the top to the bottom of the picture. The sine wave to the right of the scene illustrates the above-described variation in light.

Along any horizontal strip or

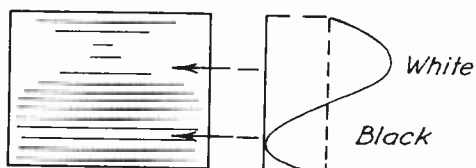

Fig. 12.--Elementary picture consisting of a variation from white to black in the vertical direction.

line there is no variation in light; hence the scanning spot generates a constant signal during each horizontal scan. But the electrical signal from one horizontal scan to the next varies in magnitude in accordance with the vertical variation in the light intensity, hence the signal can be assumed to vary sinusoidally during one complete vertical scan, i.e., its wave-shape will be similar to the sinusoidal light variation shown at the right in Fig. 12.

Assume that one complete vertical scan requires $1/30$ second. Then there will be 30 sine waves generated per second. This is the minimum number of sine waves that

can possibly be generated; the number per second is called the frequency of the wave, hence, the lowest video frequency that will be encountered will be 30 c.p.s., corresponding to the frame or picture repetition rate.

Next consider a picture having the maximum detail that can be resolved. This will generate the highest video frequency that need be amplified, and will therefore give the upper limit to the bandwidth. To estimate this value, consider the checkerboard pattern shown in Fig. 13. The squares have the minimum size that can be resolved by the eye, and are

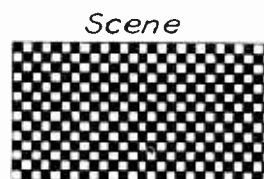

Fig. 13.--Elementary picture of a checkerboard pattern having the maximum number of variations from black to white that the eye can perceive.

alternately black and white.

Thus, as the exploring or scanning spot moves over one black and one white square, a *complete* variation in the electrical signal occurs: from maximum polarity in one direction to maximum polarity in the opposite direction. Such a *complete variation* is known as a *cycle* or *period*; this matter will be discussed more fully in a later assignment on alternating currents.

At this point it is sufficient to note that if 30 such pairs of

black and white squares are scanned in one second, then the electrical signal consists of 30 such complete variations in one second, and is therefore said to have a frequency of 30 cycles per second (c.p.s.), as was just stated above. If 4,000,000 such pairs all scanned per second, then the frequency of the resultant electrical signal is 4,000,000 c.p.s.

For the checkerboard pattern shown in Fig. 13, where each square has the height (and of course the width) of a line strip, there will be 470 elements along the vertical. However, these are scanned *at a rate* corresponding to 525 lines or elements along the vertical, although $525 - 470 = 55$ lines are deleted to permit the beam or spot to return from the bottom to the top of the picture. Since the frequency corresponds to the *rate of scanning*, the figure 525 will be employed instead of the actual 470 lines that show.

Accordingly, if there are 525 elements in effect scanned along the vertical, there will be $525 \times 4/3 = 700$ elements in effect scanned along the horizontal dimension of the picture, or in one picture time, there will be

$$525 \times 700 = 367,500 \text{ elements}$$

scanned, of which only

$$470 \times 470 \times 4/3 = 295,000 \text{ elements}$$

show, and $367,500 - 295,000 = 72,500$ elements are deleted or blanked out because of return time requirements. To repeat, the *rate of scanning* is 367,500 elements per picture.

From considerations of flicker, it is necessary to present at least

30 complete pictures or frames (as they are called) per second. This makes a total of

$$367,500 \times 30 = 11,025,000 \text{ elements} \\ \text{per second}$$

However, it has just been shown that two elements (one white and one black square) are required for one cycle of the electrical signal. Hence, the number of electrical cycles or its frequency is

$$11,025,000 \div 2 = 5,512,500 \text{ c.p.s.}$$

This is the highest frequency that will be encountered, and corresponds to the special checkerboard scene shown in Fig. 13. The actual frequencies to be encountered depend upon the particular scene scanned, and can be anywhere from 30 c.p.s., corresponding to the scene of Fig. 12, to 5,512,500 c.p.s. corresponding to Fig. 13.

This is an enormous range or band of frequencies that is required to be handled by the television system. An analogy would be an electric motor or gasoline engine that is called upon to be able to revolve at speeds from 30 revolutions per minute to 5,512,500 revolutions per minute. The latter figure would of course be impractical for a motor, but the corresponding frequency in c.p.s. is quite possible for the almost inertialess electron system used in television. Nevertheless, some formidable problems are presented to the television engineer by such a large band-width considerations.

Actually, the top frequency is less than the value of 5,512,500 c.p.s. computed above. This is because of an averaging effect in

an ordinary scene to be televised, and will be better understood with reference to Fig. 14. In (A) the

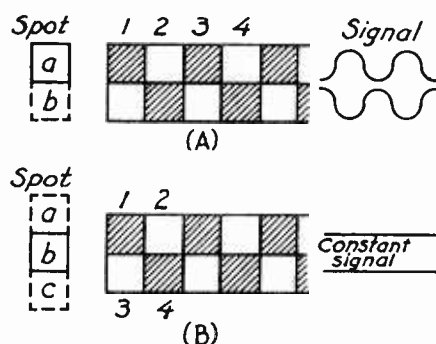

Fig. 14.--Lack of alignment of the spot with the pattern reduces the amplitude of the electrical signal.

spot is shown in positions a and b such that in either scan the spot encounters the maximum change in brightness. Thus, in position a, it first completely covers a black square 1, then a white square 2, then a black square 3 once again, and so on. The same holds for position b, and in either scan the signal has maximum amplitude.

In (B) the spot is shown so aligned with the pattern that in any of the scans; a, b, or c, it covers at any moment a black and a white square. This is because it has been displaced half a square downward (or upward) with respect to its alignment in (A). Thus, consider its activity when in position b. As it moves to cover the first square, actually its top half covers half of black square 1, and its lower half covers half of white square 3. As it moves to the right, it covers half of white square 2 and half of black

square 4.

The effect averages out to a grey in either case—there is no change or variation as it continues to the right, and the signal is constant as a grey signal. The reproduced scene on the picture tube would therefore be a uniform grey rather than a checkerboard pattern. Hence, the constant signal in this case is for all practical intents and purposes a zero signal.

Thus it is to be observed that depending upon the alignment of the checkerboard pattern with the path of the exploring spot, the signal output can vary from a maximum to what is essentially a zero signal. In the actual televising of a scene, there is no telling how the exploring spot will align with the scene detail, and the behavior is more that of chance; i.e., it is statistical in nature.

A series of experimental checks indicates that the alignment averages out such that the top frequency encountered is about 0.8 of that obtained for perfect alignment. Hence, instead of stating that the top frequency is 5,512,500 c.p.s., a closer and more accurate estimate from a practical viewpoint is $5,512,500 \times 0.8 = 4,410,000$ c.p.s. This corrected value is in itself very high, and indicates a fundamental difficulty in the design and operation of a television system.

There are more precise mathematical methods for calculating the top frequency. One such analysis yields a correction factor of .707 instead of 0.8; the agreement between the two is surprisingly close considering the former is a mathematical value and the latter is more of an experimental value.

The RMA (Radio Manufacturer's Association) standard for the channel band width is shown in Fig. 15. This is for a modulated

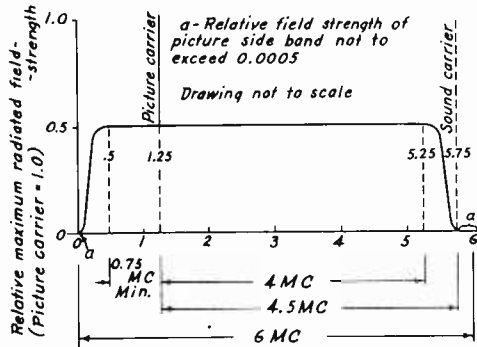

Fig. 15.--The Radio Manufacturer's Association standard for the channel band width.

carrier wave (that which is actually radiated from the television antenna) and involves the use of vestigial side-band transmission. (The latter phrase will be explained farther on in the course, and is merely mentioned here for the benefit of those who may have some knowledge of this term.)

An inspection of Fig. 15 reveals that the band of frequencies to the right of the carrier is to a point 4.5 mc. (megacycles or millions of cycles) beyond the carrier frequency, although the response is flat to but 4 mc. This checks the preceding elementary analysis fairly well, and indicates the basis for the RMA standard.

PRINCIPLES OF SCANNING

It was stated above that the band width is from 30 to 4,410,000 c.p.s. Actually, the lowest significant frequency to be encountered

is 60 rather than 30 c.p.s. (although a small 30-cycle component may be present in the electrical signal). Therefore the band width is from 60 to 4,410,000 c.p.s. rather than from 30 to 4,410,000 c.p.s., and although the reduction in band width appears slight (a mere $60 - 30 = 30$ cycles), it occurs at a point in the band where amplification is difficult, namely, the low-frequency end of the band. Hence, the need to cope with but a 60-cycle rather than with a 30-cycle component is of practical importance, not only with respect to the electrical (video) signal, but also with respect to the deflection circuits that cause the exploring spot to scan the scene.

The reason for this raising of the lowest frequency from 30 to 60 c.p.s. arises from the use of interlaced scanning, and the need for interlaced scanning arises from the characteristics of the eye with respect to flicker effects.

FLICKER FREQUENCY.—Persistence of vision provides the illusion of motion and makes both motion pictures and television possible. However, in employing this principle, certain facts must be appreciated in order that it be employed successfully. Accordingly, a somewhat more detailed discussion is necessary of this principle.

Persistence Of Vision.—The following example, while crude and perhaps not psychologically rigorous, will help to make clear the action of the mind in producing the illusion of persistence of vision. Suppose a steady light is uncovered and then covered by a revolving shutter in such manner that the light appears at full brilliance for a fraction of the

time and is then instantly and completely obliterated for another fraction of the time. The result is a rectangular pulse light stimulus, as shown in Fig. 16.

When the light suddenly flashes on the eye with full brilliance, the brain does not immediately perceive the light to maximum extent; i.e., the sensation builds up slowly toward a maximum value. When the light suddenly ceases, the sensation does not immediately

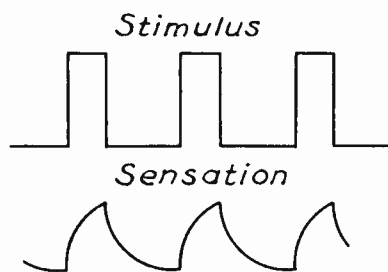

Fig. 16.--Relation between stimulus and sensation.

cease, but dies down along another curve, as it also illustrated in Fig. 16 for the sensation curve.

If the light flashes follow one another at a rate above 10 to 16 times per second, then the light will appear to be on all the time, *but to flicker considerably*. An interesting hypothetical case might be the following: Suppose an object is illuminated by this on-off light, and suppose whenever the light is on, the object is at a certain place, but whenever it is off, the object moves to some other place, only to return to the first-mentioned place when the next flash occurs.

if these flashes occur at a rate greater than 10 to 16 times per second, an observer will be ready to swear that the object is stationary, and is merely being illuminated by a flickering light. By persistence of sensation (vision) he "sees" the object even when it is not illuminated and is elsewhere.

THE STROBOSCOPE.—The above illustrates the principle of the stroboscope. If an object moves in a cyclic fashion, like a piston in a gas engine, and a flickering light, such as from a neon bulb, is flashed in synchronism with the motion of the piston, so that it always illuminates the piston for a brief instant when it is in a certain position, then the piston will appear to be stationary. This is a method employed to "arrest" motion. For example, if the piston has a slight whip or vibration at one moment in its cycle, this can be discovered by suitable adjusting of the phase or timing of the light's pulsations with respect to the piston's motion.

ILLUSION OF MOTION.—The illusion of slow motion can be obtained in the above case if the light flickers at a somewhat different frequency from that of the oscillating piston. Thus the first flash may catch the piston at the top of its stroke. If the light frequency is somewhat lower than that of the piston, then the next flash will catch the piston a little later than at the top of its next stroke, i.e., it will catch the piston when it has started to descend from its top position. The third flash will therefore catch the piston when it is still farther down, and so on.

This is illustrated in Fig. 17.

In the first flash the piston is at A; in the second, at B; in the third, at C; and so on. The sensation produced, if the rate of

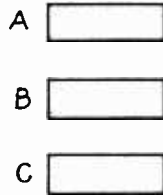

Fig. 17.--Series of "stills" of a moving piston as produced by a stroboscope slightly out of synchronism with the piston motion.

presentation is above about ten per second, is that of a piston smoothly moving through all intermediate positions from A to B to C etc.

This is possibly owing to a blending of the successive images so that while the sensation of position A is dying out and that of position B is building up, sensations of a kind of resultant character of intermediate positions are produced. Hence the piston does not appear to move in discontinuous jerks, but smoothly.

The following situation is of interest. Suppose that positions A, B, and C were reproduced in such rapid sequence that each occurred ten times or more per second. In such a case *three pistons would be seen* instead of a single moving piston. No blending or intermediate positions would be noted; apparently the sensation of no one position has time to die out before it is reestablished. If the three positions overlapped,

then under such rapid presentation three overlapping pistons would be seen, i.e., a blurred resultant image.

The significance of the three discrete images discussed in the preceding paragraph is that in television all positions of the spot of light on the fluorescent screen are presented *thirty times a second*, so that *all* positions appear simultaneously, like the three positions of the piston. Hence the sensation is that of a *complete frame*, rather than of *consecutive portions* of a frame.

On the other hand, if the variations in intensity of the reproducing beam that map out an object, were to move slowly across the screen of the picture reproducing tube, then these variations would act to present the illusion of a smooth scanning motion of the spot, as in the case of the small difference in frequency between the flashing light and the rate of oscillation of the piston. Contrariwise, if the reproducing spot moves sufficiently rapidly in scanning so as to repeat its position at any point of the screen more than 10 times a second, the eye will not be aware of its scanning motion, but instead will see it in all positions at once; i.e., all parts of the screen will appear to light up *simultaneously* in the proper proportions.

Motion Pictures.—In motion-picture projection a succession of "stills" is flashed on the screen at the rate of 24 per second (16 per second for silent film). These fuse by persistence of vision into a scene in which different objects move about. Unlike television, all parts of each frame or "still"

actually appear at once, so that persistence of vision is employed only to give the illusion of motion. In television, persistence of vision is employed, in addition, to give the illusion that all parts of any frame are being presented simultaneously. This further illusion is necessary in television since only one element is actually being reproduced at a time.

Consider, for example, the motion-picture reproduction of a vertical stick moving from left to right. As shown in Fig. 18 the first position of the stick is AB and this "still" or frame is flashed first on the screen. The next frame flashed on the screen is one in which the stick is in position CD, the third when it is in position

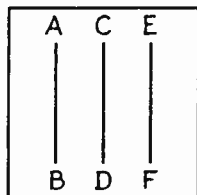

Fig. 18.--Motion-picture reproduction of a moving object.

EF, and so on. The frames appear at the rate of 24 per second. The resulting sensation is as if stick AB moved to EF through *all intermediate positions*.

An interesting point in the liberties that can be taken with the presentation of the frames. Suppose, in the printing process the first frame shows the stick in position AB, the second frame is a duplicate of the first, the third frame shows the stick in position

CD, the fourth and fifth frames show the stick in position EF, and so on. When projected, the stick will still appear to move *smoothly* from AB to EF, although more slowly than before; the duplication of alternate frames does not introduce any apparent discontinuity in the motion.

For the same speed of the film, however, the motion will appear $2/3$ as fast, or if the film is projected at the rate of $3/2$ times as fast, the motion will appear only as rapid as before. In this way silent film, run at the rate of 16 frames per second or 60 feet per minute, can be changed to a sound film that is run 50 per cent faster owing to the requirements of the sound track, or 90 feet per minute, without the motion being any faster than before. This method has enabled silent film to be converted to sound film where the picture material is of sufficient value to warrant such a transformation.

Elimination of Flicker.—Mention was made at the beginning of this section that an on-off light of sufficiently high frequency would appear to be on all the time, but would also appear to flicker or vary in intensity. Such flicker can be very annoying and tiring to the eye, and must be eliminated. The solution is fortunately simple.

If the flicker frequency is sufficiently high, then the eye will be unaware of it. The threshold or lowest frequency that the eye can detect, however, is a function of the brightness of the light, its color, and the relative duration of light and dark, as well as the part of the retina that it strikes. For example, the

outer edges of the retina are more sensitive to flicker than the fovea, and a green light, to which the eye is most sensitive, produces flicker at a higher frequency than a red or blue light of the same intensity. Light that is on for a greater fraction of the on-off period has a lower threshold frequency than light that is on for a smaller fraction of the period, as might be expected from the preceding discussion.

In motion picture work the flicker frequency is artificially raised by using two blades on the so-called flicker shutter. One blade cuts off the light while the film is in motion in the intermittent process of changing from one frame to the next; and the other blade cuts off the light while a frame is stationary and is being projected on the screen. Thus, for 24 frames per second, the flicker frequency is 48 per second, and for the rather low screen brightness ordinarily employed, is above the threshold frequency and hence is unnoticed.

The brightness of the directly viewed television picture-tube screen is somewhat higher, and the mode of presentation of the picture is also somewhat different. Tests have indicated that a flicker frequency of at least 50 cycles per second is required. Since the frame frequency is 30 per second for a 60-cycle supply, and since a flicker shutter cannot be employed because the entire frame is not reproduced as a unit, some other means must be employed to produce the required higher flicker frequency.

INTERLACED SCANNING.—An obvious solution would be to increase

the number of frames to 60 per second. This, however, would double the top frequency and hence the band width, and is therefore undesirable. As a result, another method has been employed that is very ingenious, and that retains the original band width while apparently doubling the flicker frequency. This is the process known as *interlaced scanning*.

Instead of scanning the first, second, third, etc., lines in consecutive sequence, lines 1, 3, 5, 7, etc., are scanned in one-half a frame time, or 1/60 second, and then lines 2, 4, 6, 8, etc., are scanned in the second half or second 1/60 second. Thus, two half pictures, or fields—as they are called—are scanned, such that they are interlaced with one another and together constitute a complete frame or picture having the desired detail. Each field, however, presents to the observer an essentially complete picture as far as flicker is concerned, so that the apparent flicker frequency is sixty per second and hence unnoticed. But the actual number of frames or complete pictures is still 30 per second, so that the band width is *unchanged*.

There is some slight interline flicker produced, but this is in general not particularly noticeable and hence not objectionable. There may also be observed in the case of fast moving objects that the even and odd line details of the object are slightly displaced with respect to one another owing to the 1/60 second difference in time between the reproduction of the two sets, but again this is not noticeable unless looked for, and 2 to 1 interlaced scanning, as this is

called, is apparently here to stay.

Indeed, some—notably DuMont—have advocated as high as 4 to 1 interlacing, but it has been decided that the interline flicker is too noticeable in this case, and the difficulties incurred in making the four sets of scans interlace, too great. In addition it is felt that the distortion of moving objects will be too great.

Besides the advantage of higher flicker frequency for the same band width, interlaced scanning has another advantage not always appreciated. The vertical scanning frequency is 60 cycles per second instead of 30.

As a result, certain electrical wave-shapes, required for deflection, etc., occur at a 60-cycle instead of 30-cycle repetition rate. As will be shown later, it is easier to amplify the higher frequency waves, and certain economies result, particularly in the receiver. Hence interlaced scanning is welcome for this feature alone.

It must not be supposed, however, that there is no 30-cycle component in the picture signal. If the picture is such that the wave-shape for the entire odd-line scan is different from that for the even-line scan, then some 30-cycle fluctuation is present in electrical signal. Its magnitude, however, is in general small, and is apparently satisfactorily handled by a video amplifier system that is carefully compensated down to 60 cycles.

PRACTICAL METHOD OF INTERLACING.—The practical method of obtaining interlaced scanning is in itself ingenious, and will now be discussed. In order to appre-

ciate its application, it will be necessary to go into the mechanism of scanning and particularly the motion of the scanning beam.

In Fig. 19 is shown the path of the moving spot for two-horizontal scans. As the beam moves from left to right at the high horizontal velocity, it is also simultaneously moving downward at the lower vertical velocity. The resultant motion is somewhat obliquely downward to the right, and thus is shown in exaggerated form by AB and CD in the figure. The

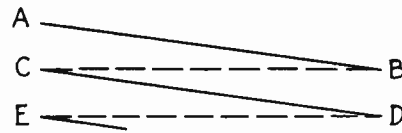

Fig. 19.--Horizontal scanning motion.

horizontal return strokes, BC and DE, are so much faster that they are more nearly horizontal. In actual practice the slopes are very small because the forward horizontal motion is approximately $525 \div 2 = 262.5$ times as rapid as the vertical motion; nevertheless, the resultant slope will be found to be important in the practical system.

In interlaced scanning, the vertical frequency is 60 instead of 30 c.p.s., so that the vertical velocity is twice as fast, and the downward slope is therefore twice as great. Suppose, for simplicity, that there are only four horizontal scans per vertical scan, and that *these are interlaced as shown in Fig. 20.* For simplicity, zero horizontal and vertical return times

are assumed, so that the horizontal return lines (if they showed) would be horizontal, and the vertical return lines would be vertical traces at the left-hand side of the picture.

In Fig. 20, the odd lines 1 and 3 are represented by the solid lines AB and CD respectively, and the even lines 2 and 4 by EF and GH, respectively. The first (odd) scan is along AB, BC, CD, DD', thence up to E. Note that E must

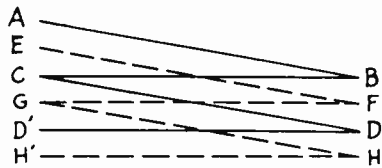

Fig. 20.--Elementary example of interlaced scanning.

be half-way between A and C in order to represent the start of line 2. The second (even) scan is along EF, FG, GH, HH', and thence back to A. Hence the amplitudes of the first and second vertical scans are AD' and EH', respectively. While these are equal, note that they are staggered, so that the first vertical return is the shorter distance D'E, and the second is the longer distance H'A.

Corresponding to this irregular scanning motion are two so-called deflection currents that flow in two sets of coils of wire called deflection coils. Each pair of coils fits around the neck of the camera tube in the studio and the neck of the picture tube in the home receiver. In Fig. 21 is shown the two sets of deflection coils that fit around the neck of the

picture tube.

In (A) is shown a cross-sectional view, and in (B) is shown a side view. In (A), one set of deflection coils is denoted by AA'; and the other set by BB'. Two separate currents flow: one in AA'; the other, in BB'. Each current sets up a magnetic field through its set of coils and the portion of the neck between the two coils of the set, and this magnetic field deflects the electron beam passing axially along the tube

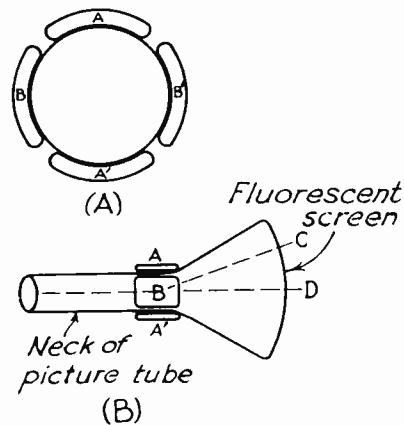

Fig. 21.--Cross-sectional and side views of the picture tube, showing the deflection coils and their position on the neck of the tube.

to the end where the fluorescent screen is located.

The electrons, upon striking this screen, cause it to glow, or fluoresce. When no currents flow through the coils, the beam is undeflected, and strikes the screen at D in Fig. 21(B), whereas if current flows in the side coils BB', an upward (or downward) deflection occurs so that the beam strikes the screen, say, at C. Note

that the deflection is at right angles to the coil position; this is a characteristic of magnetic deflection, and will be covered in much greater detail in later assignments.

The deflection is in direct proportion to the magnitude of the electric current. If the beam is to move or scan with time, then the magnitude of the current must likewise vary with time. In particular, for deflection to one side of the center position D, the current must flow through the appropriate set of coils in one direction; for deflection to the other side of D, the current must flow in the reverse direction through the coils.

Normally, it is desired that the beam move with uniform velocity across the fluorescent screen. This means that the current flow must vary uniformly from a maximum in one direction through the coils, through zero to a maximum in the opposite direction. This behavior of the current is best represented by a graph in which the current magnitude or strength is plotted against time. Such a plot is shown Fig. 22. Time is assumed to progress from left to right. At some moment when the phenomena is first observed, time is considered to be zero (point 0 in Fig. 22); earlier moments of time will therefore be considered negative, i.e., prior to the starting moment.

In a similar manner, current through a given set of deflection coils will be plotted vertically. If it flows in one direction through the coils, it will be plotted below the horizontal time axis; if it flows in the opposite direction,

it will be plotted above the time axis. For convenience, the former direction will be considered as corresponding to a negative magnitude, and the latter direction as corresponding to a positive direction.*

Suppose at time $t = 0$ the current is at a negative maximum denoted by A in Fig. 22. Assume that the current under consideration

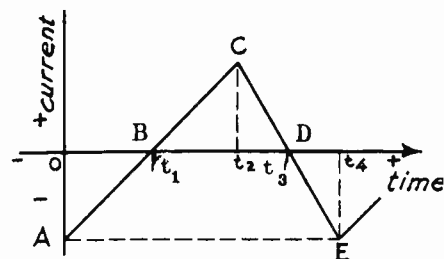

Fig. 22.--Sawtooth current required to move the beam in a scanning manner.

is that producing *vertical* deflection, and that a negative maximum causes the beam to move to the *top* of the tube. Its position is denoted by A in Fig. 23; this corresponds to current magnitude OA in Fig. 22. Then, as the current decreases in magnitude with time, the beam moves down, until when the current is zero (point B in Fig. 22), the beam or spot is at the center of the screen (position B in Fig. 23). The time required

*Much more information concerning graphs will be given in a subsequent assignment on graphical analysis. The student will observe at this point how important mathematics in its various branches is to television.

for this motion to take place is denoted by t_1 in Fig. 22.

The current now starts to increase uniformly in the *opposite* direction through the deflection coils, until at time t_2 , it attains its maximum amplitude C (Fig. 21) in this direction. The beam correspondingly moves downward to position C in Fig. 23 at the bottom of

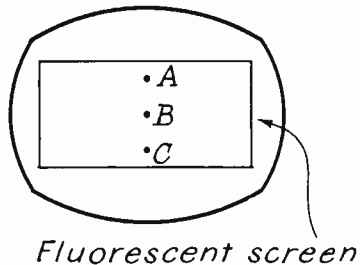

Fig. 23.--Various positions of the beam or spot on the fluorescent screen of the picture tube, corresponding to current magnitudes in Fig. 21.

the screen.

The current now starts to decrease to zero, point D, at time t_3 ; the beam moves back to point B (return stroke). The current now builds up to its negative maximum E at time t_4 , where E is as much below the time axis as A is. The beam continues to move upward until it reaches position A once again. This sequence of operations is repeated over and over again; the result is the *vertical component* of the complete scanning motion of the beam on the fluorescent face of the picture tube.

Note that the time required

for the current to vary from A to C is t_2 ; this corresponds to the downward motion of the beam from A to C. The time required for the current and hence beam to return to their initial points is $(t_4 - t_2)$; this is called the return or "flyback" time. From practical considerations as little time as possible is desired for flyback, hence $(t_4 - t_2)$ is made as much shorter than t_2 as possible. Hence the slope of line CE in the graph is much steeper than that of AC; nevertheless, the graph has the appearance of a sawtooth, and the deflection current is usually referred to as a sawtooth current.

A similar sawtooth current flows in the other pair of coils that produces horizontal deflection. However, since many horizontal strokes or scans occur in the same time as one vertical scan, it is clear that the time allotted to one horizontal scan is but a fraction of that allotted to a vertical scan; specifically, there will be $525/2 = 262.5$ horizontal scans to one vertical scan. This is suggested in Fig. 24. There are 262.5 horizontal sawtooth waves for each vertical sawtooth wave. In order to conserve space, a break has been made in the figure during which the majority of the horizontal sawtooth waves occur; only the first few and the last few are shown.

The duration of one horizontal scan (one forward and return stroke) is $1/15,750$ sec., while the duration of one vertical scan is $1/60$ sec.

Thus

$$\left(\frac{1}{60}\right) \div \left(\frac{1}{15750}\right) = \left(\frac{1}{60}\right) \left(\frac{15750}{1}\right) = 262.5$$

or—as stated previously—there are 262.5 horizontal scans to one vertical scan.

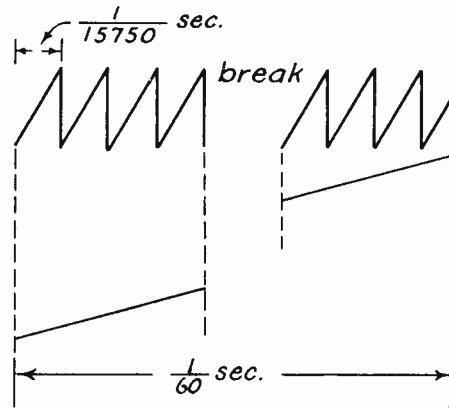

Fig. 24.--Relation of horizontal to vertical sawtooth waves.

Returning to the matter of interlaced scanning, if the scanning sequence of Fig. 20 were employed, then—since the even return stroke H'A is greater than the odd return stroke D'E—alternate vertical sawtooth waves would have to be of different amplitudes. The appearance of the vertical wave would be as in Fig. 25; for convenience,

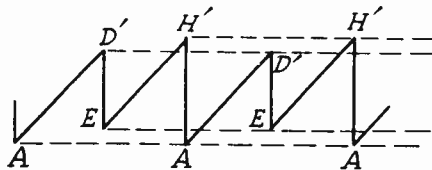

Fig. 25.--Vertical deflection wave required to produce vertical deflection shown at the right in Fig. 20.

Fig. 20 is repeated next to it, and the letters in the two figures correspond.

The wave of Fig. 25 is very difficult to produce electrically and maintain at the exact relation of alternate heights necessary to produce the scanning pattern of Fig. 20. On the other hand, if all sawtooth scans or cycles could be of equal amplitude, then the difficulty of generating such a wave would be far less. This is possible if the ratio of the horizontal frequency to the vertical frequency is not a whole number; specifically, for two-to-one interlacing is shown in Fig. 20, the frequency relationship should be a whole number (integer) plus one-half, such as $262 + 1/2 = 262.5$.

The reason is quite simple, and is as follows: Suppose the first horizontal scan and the first vertical scan start out in time or synchronism. Then, at the end of the first vertical scan, 262 horizontal scans will have been completed plus an additional half horizontal scan. As a result, at the start of the second vertical scan, the last half of the above horizontal scan is completed, and

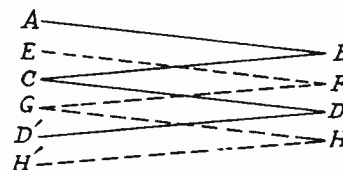

Fig. 20.--Elementary example of interlaced scanning.

then 262 additional scans, at which time the second vertical scan is completed.

The third vertical scan starts out in time with the next horizontal scan, and thus duplicates the activities of the first vertical scan. The fourth vertical scan thereupon duplicates the activities of the second vertical scan; in short, the odd vertical scans are all alike, and the even vertical scans are all alike, but different from the odd scans. It is this difference in alignment of the horizontal scans with the odd and with the even vertical scans that produces the interlacing effect.

This can be seen from Fig. 26. Here, for simplicity, only 3 1/2 horizontal scans are assumed per

first vertical scan or field is completed, and so the beam immediately appears up at 7' at this instant (because zero return time is assumed).

The second or even field is shown at (B). The last half of horizontal scan 7' is first completed, then even lines 2, 4, and 6 are scanned. Since this field started out with a half line, it ends with a full line as shown. Furthermore, since zero return time is assumed for both horizontal and vertical deflection, the spot, upon completing line 6, immediately appears at the top left-hand side of the picture as point 1.

It thereupon traces out a field that is identical to (A), the next field is identical with (B), and

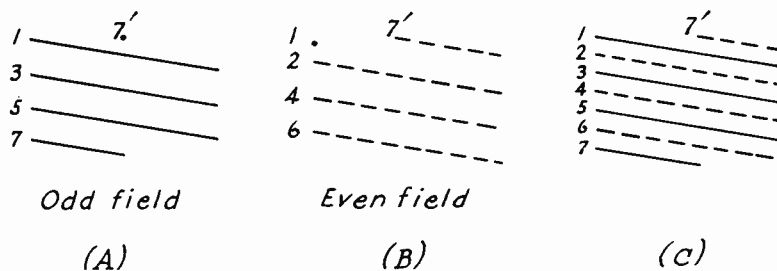

Fig. 26.--Method of obtaining 2:1 interlacing by the proper ratio of horizontal to vertical scanning frequencies.

vertical scan, and also zero return time is assumed for both. For clarity, the return strokes have been omitted in the figure. In (A) the first or odd field is shown. The sequence is line 1, 3, 5, and 7. However, only half of line 7 is scanned by the time the

so on. The superposition of (A) and (B) is shown in (C); the odd fields are shown in solid lines, and the even fields in dotted lines. Observe particularly how the even fields fall between the odd fields. This results from the slanting path of the spot as a

result of the combined motion sideways (horizontally) and vertically.

Consider, for example, scan 1 in (C) Fig. 26. Since this scan is clear across the fluorescent screen, the right-hand end of the scan is below the left-hand end by a certain amount. On the other hand, scan 7' is only half a scan, hence, if 7' is at the same height as 1, its right-hand end will be only half as far down as the right-hand end of 1. As a result, scan 2, which starts at the same height as the right-hand end of scan 7', will therefore be halfway between 1 and 3, and thus will trace a line halfway between 1 and 3, as shown.

Thus, interlaced scanning is obtained by virtue of the special relationship between the horizontal and vertical deflection frequencies. Observe from (C) Fig. 26 that even and odd scans are of the same total height; the vertical sawtooth wave can *therefore be of constant amplitude*, rather than of alternately larger and smaller amplitudes as was illustrated in Fig. 25. This, as explained previously, results in a much simpler and more practical design for the vertical deflection circuit, which is of particular importance in the case of the television receiver.

The question may arise as to whether it is not as difficult to maintain the particular relationship between the two deflection frequencies as it is to obtain the staggered amplitude variation of Fig. 25 that would otherwise be necessary. The answer is in the negative; in a later assignment on the synchronizing generator it will be shown how the necessary frequency relationship is com-

paratively easy to obtain and maintain.

The frequency ratio in the case of the simplified example illustrated in Fig. 26 is $3\frac{1}{2}$ to 1; .e., the horizontal frequency is $3\frac{1}{2}$ times the vertical frequency. In actual practice, where many more lines per picture are employed, the ratio is $262\frac{1}{2}$ to 1. In an older system of somewhat fewer lines (441), the ratio was $441/2 = 220\frac{1}{2}$ to 1. The number of lines in the complete picture is double this ratio, which is a whole number (integer) plus $1/2$.

Doubling the integer portion always gives rise to an even number, since an even number is—by definition—a number that can be divided by two without a remainder. Doubling $1/2$ gives 1. Therefore, the total number of lines in a picture is an even number plus one, and this—by definition—is the next *odd* number after the even number. Hence, the method of obtaining interlacing by the use of the above frequency ratio always results in an odd number of lines for the picture, and this method of interlacing is therefore often referred to as *odd-line interlacing*. Thus, $2 \times 3\frac{1}{2} = 7$; $2 \times 220\frac{1}{2} = 441$; $2 \times 262\frac{1}{2} = 525$, all odd numbers.

Several further points are of interest here. Odd-line interlacing depends upon the frequency ratio given above and upon constancy of amplitude of the vertical sawtooth wave. In practice, absolute constancy of amplitude over a period of hours is not possible. However, if the amplitude changes slowly, or if abruptly but only at infrequent intervals, then a reasonably steady picture well interlaced will be obtained; an abrupt

change will cause but a momentary disturbance and interlacing will be resumed once the vertical amplitude again becomes constant.

Another point is that in the previous analysis, zero return time for both horizontal and vertical scanning was assumed.

This, however, is not at all necessary; the system will interlace for any value of return time. Consider horizontal return time. The situation is portrayed in Fig. 27. For zero return time, the path is ABC, where BC is horizontal. If the return time is not zero, then *less time in the cycle* is available for the *same length* of forward stroke, so that the forward stroke will not slope as much. The forward path is therefore AB' instead of AB. Since the return stroke takes an appreciable

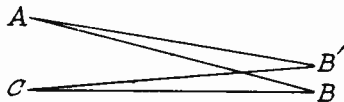

Fig. 27.--Effect of horizontal return time.

ciable time, it will have some slope, namely B'C. Since the time for the horizontal cycle is assumed the same in either case, the total downward or vertical component of motion A to C, will be the same in either case. Hence the next line starts from C regardless of the amount of time devoted to the horizontal return stroke.

Next consider vertical return time. The solid lines in Fig. 28

represent the horizontal scans occurring during the downward (forward) vertical stroke. If the vertical return time were zero, the horizontal strokes would continue downward as per the broken lines to B, and then instantly return to C directly over B. If, however, vertical return starts earlier at A, then all the broken lines from A to B will proceed upward to C, instead of downward to B and then instantly upward to C.

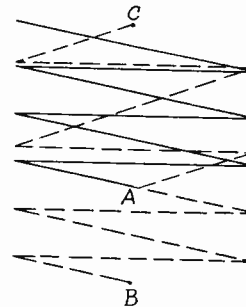

Fig. 28.--Effect of vertical return time.

The actual vertical return path therefore will be the upward dotted line path from A to C. However, this is immaterial as far as interlacing is concerned, for the next field starts in either case at C, half-way across the top line, which is the condition for odd-line interlacing. Moreover, since the beam is blanked out or extinguished on the return path, the actual shape of the path is immaterial; it can contain many or few horizontal strokes. The only important consideration is that of timing, if the frequency relationship is an integer plus $1/2$, interlacing will be obtained.

A further point is that it is not even necessary for the first field to start exactly at the upper left-hand corner, and the next field half-way across on the top line. Either odd or even field can start at any point on the first line, provided that the other field starts half a line away from where the first started. But this again is simply a question of frequency relationship, and with proper design of the Synchronizing Generator, satisfactory interlacing will be obtained.

In practice interlacing is usually not perfect, mainly owing to departures in the Synchronizing Generator from the exact frequency relationship required. The result is generally that the one field is shifted slightly up or down relative to the other, so that the lines are alternately closer together and farther apart. This effect is known as "twinning", and can be appreciable. (see Fig. 29).

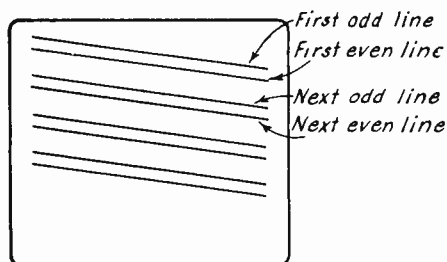

Fig. 29.--Appearance of twinning of even and odd lines.

In many cases the twinning is not constant, but "jittery". The effect on the reproduced picture is not too serious, but an examination of the scanning pattern in the

absence of a picture signal—as when the gain or volume control in the receiver is turned down, will show the scanning lines only occasionally; at all other times they are blurred.

BRIGHTNESS AND CONTRAST.—The definition of brightness will be given in a later chapter on light and optics. For the time being, we can accept this term in its every-day meaning; it indicates the surface density or concentration of the intensity of the light, and is measured in candles per sq. ft. or per sq. meter or sq. cm. The eye perceives difference in brightness between two objects, rather than the total light flux (lumens) that they emit or reflect, as the case may be.

As in the case of all our sensory organs, the eye has a threshold level, below this no change in sensation is experienced. For example, light may change in brightness from zero brightness up to a certain small value before any sensation of light is perceived at all; the brightness may change by an appreciable amount from one level to another level, higher or lower, before any change in sensation is experienced. In other words, not only is there a threshold value or minimum value for brightness, but there is also a minimum value for *change in brightness* that can be perceived.

Thus, if an object has a brightness of 10 candles per sq. meter, and the brightness increases by 0.1 candle per sq. m., it will be found that this change in brightness will not be perceived. But when the object increases its brightness to 10.2 candles per sq.m., the change is just perceived.

For 100 candles per sq.m., the threshold value is 2 candles per sq.m., change; i.e., the brightness must change to 102 candles/sq.m. before the change is perceived.

Consider now the ratio of the change in brightness that can just be perceived (threshold) to the brightness level at which this change is considered. For example, at 100 candles/sq.m. the threshold change is 2 candles-sq.m., and the ratio is $2/100 = 0.02$. Similarly, at 50 candles/sq.m. the change is 1 candle/sq.m. and the ratio is again $1/50 = 0.02$. The same is true for 10 candles/sq.m. level and 0.2 candle/sq.m. threshold change.

Indeed, over a range of brightness from about 1 to 100,000 candles per sq.m., this ratio is practically constant at 0.02 or 2 per cent. It means that over this large range a 2 per cent change in brightness must occur before it is perceived. Note that it is the above *ratio*, *quotient*, or *percentage change* that is constant over the range. The actual numerical change must then be large for high brightness levels, such as 2 candles/sq.m. for a 100 candle/sq.m. level, and low for low brightness levels, such as 0.2 candle per sq.m. for a 10 candle per sq.m. level, in order that the percentage change be constant.

From this it results that the sensation of light that is perceived by the brain *varies as the logarithm of the actual external light stimulus*. The relationship is plotted in Fig. 30, where B represents brightness; ΔB , the threshold change in brightness and $\Delta B/B$ their ratio. Its significance is that the eye automatically adapts itself as to sensitivity so

that very bright lights do not appear to the brain very much brighter than dim lights. For example, this page, when viewed under artificial illumination of low brightness level, does not appear much

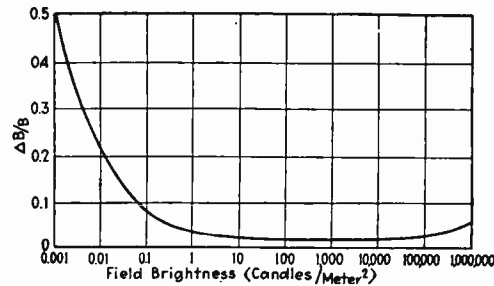

Fig. 30.--Relation between percentage threshold change in brightness and brightness level.

darker than when viewed in daylight of high illumination level. The sensitivity of the eye automatically decreases as the level of illumination increases, and in this way the eye can accommodate itself to an enormous range of brightness. Thus, when the brightness changes 100,000-fold, the sensation in the brain changes as the logarithm of 100,000 or only 5-fold.*

PRACTICAL IMPLICATIONS.—The above relationship has several important practical implications. The brightness between two adjacent

*Logarithms are discussed in an assignment following this one very shortly.

areas of the scene must differ by at least 2 per cent ($\Delta B/B = .02$) in order that the difference be perceived by the eye. Actually, a value of 4 per cent is probably more accurate for the ordinary viewing of the scene, in which the attention is not too closely riveted on any two areas.

An important consequence of this is the fact that the contrast between two areas of a scene is *not* changed whether the scene is illuminated by a strong or weak light. For example, suppose two adjacent areas A and B of a picture are illuminated by a light such that area A has a brightness of 1 candle per sq.m. and area B has a brightness of 1.5 candle/sq.m. (The reason for B being brighter than A is that it reflects more and absorbs or transmits less of the light falling upon it than does A.)

The numerical difference in brightness is $1.5 - 1 = 0.5$ candles per sq.m. However, as was just explained, the numerical difference

is not the important criterion as to their difference in contrast, but rather the *ratio* of their brightnesses, namely, $1.5/1 = 1.5$ or 150 per cent. Since B is 50 per cent brighter than A, and only 4 per cent change is required for the two to be distinguished, the contrast between the two will be readily perceived by the observer.

Now suppose the light intensity is increased ten-fold. Then A will have a brightness of $10 \times 1 = 10$ candles/sq.m., and B will have a brightness of $10 \times 1.5 = 15$ candles/sq.m. The numerical difference in brightness is now $15 - 10 = 5$ candles/sq.m., but the ratio is still $15/10 = 1.5$ or 150 per cent, and so the two areas will appear to have the *same contrast* as before, although both will be brighter. This is illustrated in Fig. 31.

In a television receiver there is a control very similar to the volume control in a radio receiver. This control is often called the contrast control; it regulates the

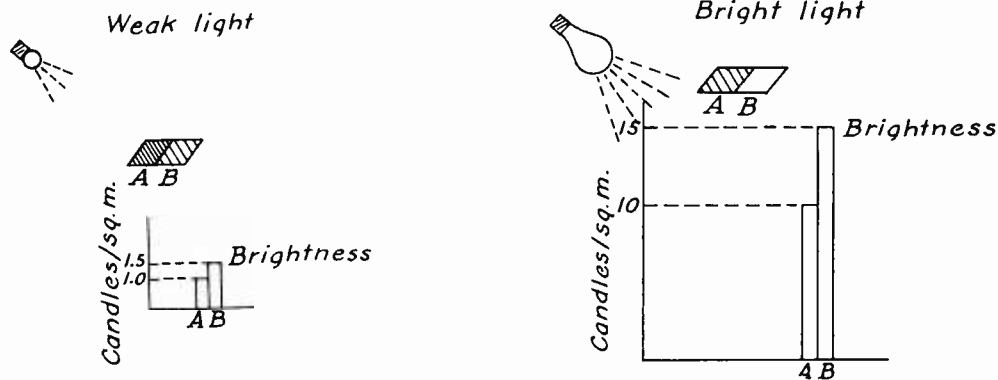

Fig. 31.--The contrast between two areas A and B is the same whether they are illuminated by a small lamp or by a lamp ten times as bright.

strength of the electrical (video signal) that actuates the picture tube and determines how brightly its fluorescent screen will glow. The electrical signal causes the electron beam scanning the screen to vary in intensity in accordance with the brightness of the corresponding elements of the scene in the studio.

If the control is turned down, the electrical signal is of small amplitude (see Fig. 31); if the control is turned up, the signal is of large amplitude, but of course similar in shape. For the small signal of (A) Fig. 32 the

the light in the room where the picture tube is viewed. The situation is now different from that portrayed in Fig. 31. There the reason for elements A and B being seen (for having brightness) is that they reflect light from the primary light source; i.e., they are dependent upon the light source for their emission of light. In the case of the picture tube, however, the screen itself emits light owing to the electron beam bombardment; the room light is a disturbing factor that interferes with the contrast and distinguishability between various elements of

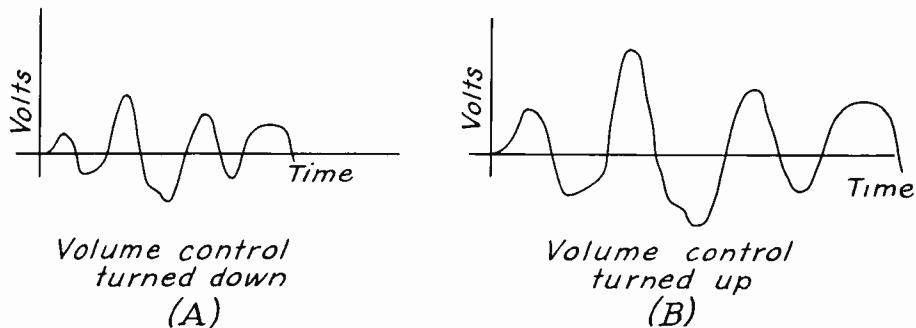

Fig. 32.--Effect of volume control on video signal.

successive elements of the screen all glow with a weak light; for the large signal of (B) they glow with a much stronger light. However, so far as the *ratio* of brightnesses of different parts of the screen is concerned, its value is the same for (A) as for (B). Therefore, there will be no difference in *contrast* whether the volume control is turned down or turned up, hence this volume control is hardly to be considered a contrast control from this analysis.

Consider next the effect of

the fluorescent screen because it illuminates all portions of the screen uniformly and hence in a manner unrelated to the way in which various portions of the screen should glow to reproduce the original studio scene.

To show the effect, suppose the receiver is in a room of total darkness, and consider two areas of the fluorescent screen. Assume one glows with a brightness of 1 candle per square foot, and the other area glows with a brightness of 0.6 candle per sq.ft. The

brightness ratio, upon which the contrast depends, will be $1/0.6 = 1.67$. Suppose, however, the room illumination adds 1 candle/sq.ft. of constant brightness to all parts of the screen. Then the total brightness of the first is $1 + 1 = 2$ candles/sq.ft. and that of the second is $1 + 0.6 = 1.6$ candles per sq.ft.

The ratio is now $2/1.6 = 1.25$, or less than the previous value of 1.67. The effect of the incident

rized in Fig. 33. Exactly similar results are to be observed in motion picture projection. The brightness of the motion picture screen is ordinarily less than that of a television picture tube. It is therefore necessary to view the screen in an essentially darkened room or theatre in order to obtain the full benefit of the contrast in the picture.

When light is admitted to the room, as when the blinds are opened,

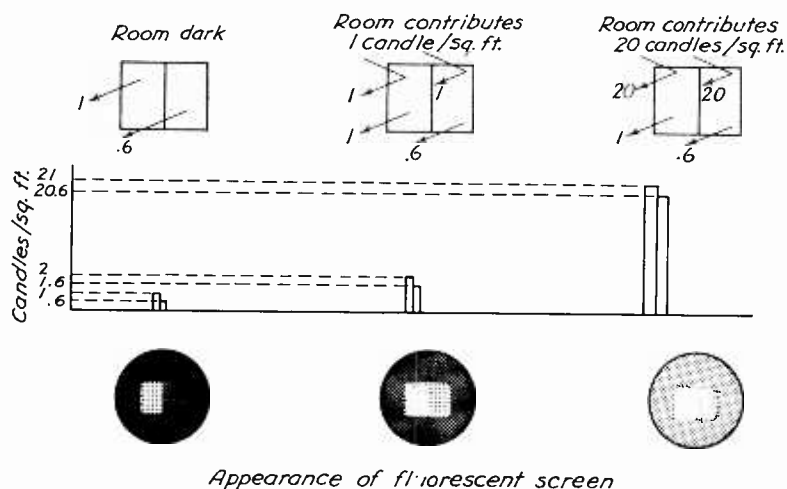

Fig. 33--Effect of room illumination on contrast of two areas of fluorescent screen.

room illumination has been to decrease the contrast between the two areas. If the room illumination had been such as to produce a brightness of 20 candles/sq.ft. to each of the two areas, then the ratio would have dropped to $(20 + 1) \div (20 + 0.6) = 21/20.6 = 1.02$. In this case the first area would be only 2 per cent brighter than the second, and the contrast would be just at the threshold value!

The above results are summa-

the picture appears to be washed away; all contrast appears lost. This has a direct bearing upon a practical matter concerning television. If television is to be practical in the home, it must be able to operate in at least a dimly illuminated room, since people will wish to walk around and not be constrained to sit continuously in the dark. If this is the case, then fairly high levels of screen brightness are necessary, and this

is not easy to obtain, especially in the case of projection picture tubes whose images are optically enlarged, if tubes of satisfactory life are desired.

As a final problem, consider the case just analyzed where the room illumination produces a bright-

ratio is $(4 + 1)/(2.4 + 1) = 1.47$, or greater than the previously computed value of 1.25, and closer to the value of 1.67 for a completely darkened room. This indicates that the volume control can act as a contrast control in the presence of room illumination.

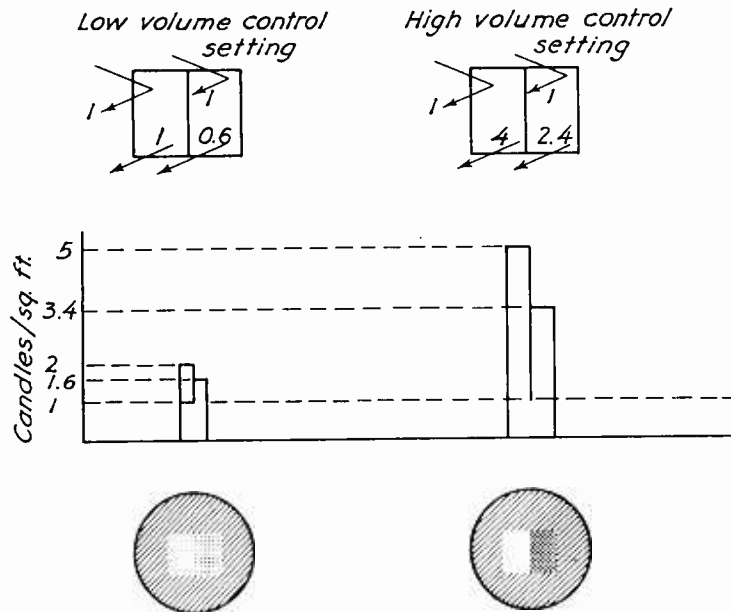

Fig. 34.--Effect on contrast of volume control setting in the presence of room illumination.

ness of 1 candle/sq.ft. on the screen. The brightness ratio of the two areas was found to be $2/1.6 = 1.25$ instead of the higher value of $1/.6 = 1.67$ when the room was dark. Now suppose that the volume control is turned up to a point where the light emitted from the two areas of the screen is 4 and 2.4 candles/sq.ft. respectively.

If the room contributes 1 candle/sq.ft. uniform brightness to the screen, then the brightness

because it now controls only that part of the light coming from the screen that is generated within the picture tube. The effects are summarized in Fig. 34, and it is clear from the figure that the contrast is greater at the higher volume control setting.

In a subsequent assignment on picture tubes, it will be shown that even in a totally dark room the ratio between maximum and minimum brightness of two areas of the fluorescent screen is limited

to about 25 to 1. The reason is that even if a portion of the screen is not energized by the beam and thereby caused to emit light, it does receive light from bright portions of the screen through internal reflections within the tube, and therefore is not completely dark. However, the discussion above concerning the volume control and room illumination does indicate how the characteristics of the eye must be taken into account in designing and installing a television system.

CONCLUSIONS

It should be clear by now to

the reader that a successful television system must be one that is fitted to the characteristics of the eye, and that by a proper study of the latter, profitable and important improvements can be made in the system. Thus, by knowing the limitations and requirements of the eye as to resolution, no useless effort is expended in trying to make the resolution of the television system greater than that demanded by the eye; by noting the characteristics of persistence of vision, interlaced scanning is employed to reduce the band width; and by studying the contrast characteristics of the eye, improvements in the system and in the receiver controls may ultimately be achieved.

MECHANISM OF THE EYE

EXAMINATION

SHOW ALL WORK:

1. What is the function of each of the following components of the eye?

(A) the iris

To vary the opening in accordance with the intensity of incident light. ✓

(B) the lens

To change the focus of the eye. ✓

(C) the retina

Collect the image and transmit it to the optic nerve. ✓

(D) the fovea

Give the sharpest vision of the object being concentrated on. ✓

(E) the muscles attached to the eyeball

To vary the bulge of the lens, thus changing the focus and giving what is called the "accommodation" of the eye. ✓

2. (A) What feature of the construction of the eye determines its ability to resolve detail.

The diameter and spacing of the cones in the fovea. ✓

- (B) How is the resolving power to the eye expressed, and what is an average value for this quantity? ✓

Angular separation of two objects being viewed.
Average value is 1.5'

3. What factors determine the viewing angle, and what is the commonly accepted average for this?

If the viewing angle is too large the eyes will become fatigued from their movement - necessary to bring all successive points into focus on the fovea. The accepted average viewing angle is 15°. ✓

MECHANISM OF THE EYE

EXAMINATION, Page 2.

4. (A) Suppose the angle of resolution is $2'$ of arc, and the viewing angle is 20° . Into how many lines should the scene be resolved?

$$\frac{20 \times 60}{2} = 600 \text{ lines} \checkmark$$

- (B) What is the aspect ratio employed in television.

$$4/3 \quad /$$

5. Suppose the number of lines in a television picture is 625; the picture repetition rate is 25 per second, and the usual aspect ratio is employed.

- (A) What is the highest picture frequency, using a reduction factor of 0.8?

$$\text{Elements/sec} = 625 \times (625 \times \frac{4}{3}) \times 25 \times 0.8 = 10,443,333$$

$$\text{Frequency} = \frac{10,443,333}{2} = \underline{\underline{5,221,666 \text{ CPS}}} \quad /$$

- (B) Suppose 2 to 1 interlacing is employed. What is the lowest important picture frequency?

$$\text{Lowest important frequency will be } \underline{\underline{50 \text{ CPS}}} \quad /$$

MECHANISM OF THE EYE

EXAMINATION, Page 3.

6. A stroboscope is used to measure the speed of a rotating shaft by illuminating a mark or dot on the shaft. When the frequency of the light flashes from the stroboscope reaches a value of 60 per second, the dot on the shaft appears to stand still. What are the revolutions per minute of the shaft?

$$60 \times 60 = 3600 \text{ RPM. } \checkmark$$

7. A scene is illuminated by a light that flickers at the rate of 40 variations per second. At this frequency the light flicker is not noticed by the eye. The light is then made brighter, and the flicker becomes apparent. The rate of flicker or flicker frequency is then raised to 60 variations per second, and at this higher frequency is once more not noticed by the eye. Explain the above phenomena in terms of the characteristics of the eye.

The flicker threshold frequency discernible by the eye is dependent, among other factors, on the brightness of the light. Increasing the brightness increases the threshold frequency.

MECHANISM OF THE EYE

EXAMINATION, Page 4.

8. (A) How does interlaced scanning reduce the flicker effect in a television picture?

By scanning first the odd lines in one half a frame time and then the even lines, two half pictures ~~are~~ (called fields) are obtained in a frame time thus effectively doubling the flicker frequency

- (B) What other beneficial effects are obtained?

The vertical scanning frequency is raised from 30 to 60 cps. Wave shapes for deflection are easier to amplify at the higher frequency.

9. Explain briefly how odd-line scanning produces interlacing with a constant amplitude of the vertical deflection wave.

This is accomplished by having an odd number of lines. At the end of the first field the first half of the last horizontal line is scanned. Beginning the second field the last half of the first line is scanned. This makes the distance back from the end of one field to the start of the next the same each time.

10. A picture tube in the dark produces a maximum brightness of 7 candles/sq. ft., and a minimum brightness 0.14 candles per sq. ft. The screen is viewed in a room that produces a uniform brightness of 1 candle/sq. ft. upon the screen. What is the contrast ratio in the dark, and what is it in the lighted room?

$$\frac{7}{0.14} = \underline{\underline{50}} \text{ in the dark.}$$

$$\frac{7+1}{1+0.14} = \frac{8}{1.14} = \underline{\underline{7.01}} \text{ in lighted room}$$