



# PHONO PICKUPS AND RECORD CHANGERS

*Lesson* RRT-7



## DE FOREST'S TRAINING, INC.

2533 N. Ashland Ave., Chicago 14, Illinois

RRT-7

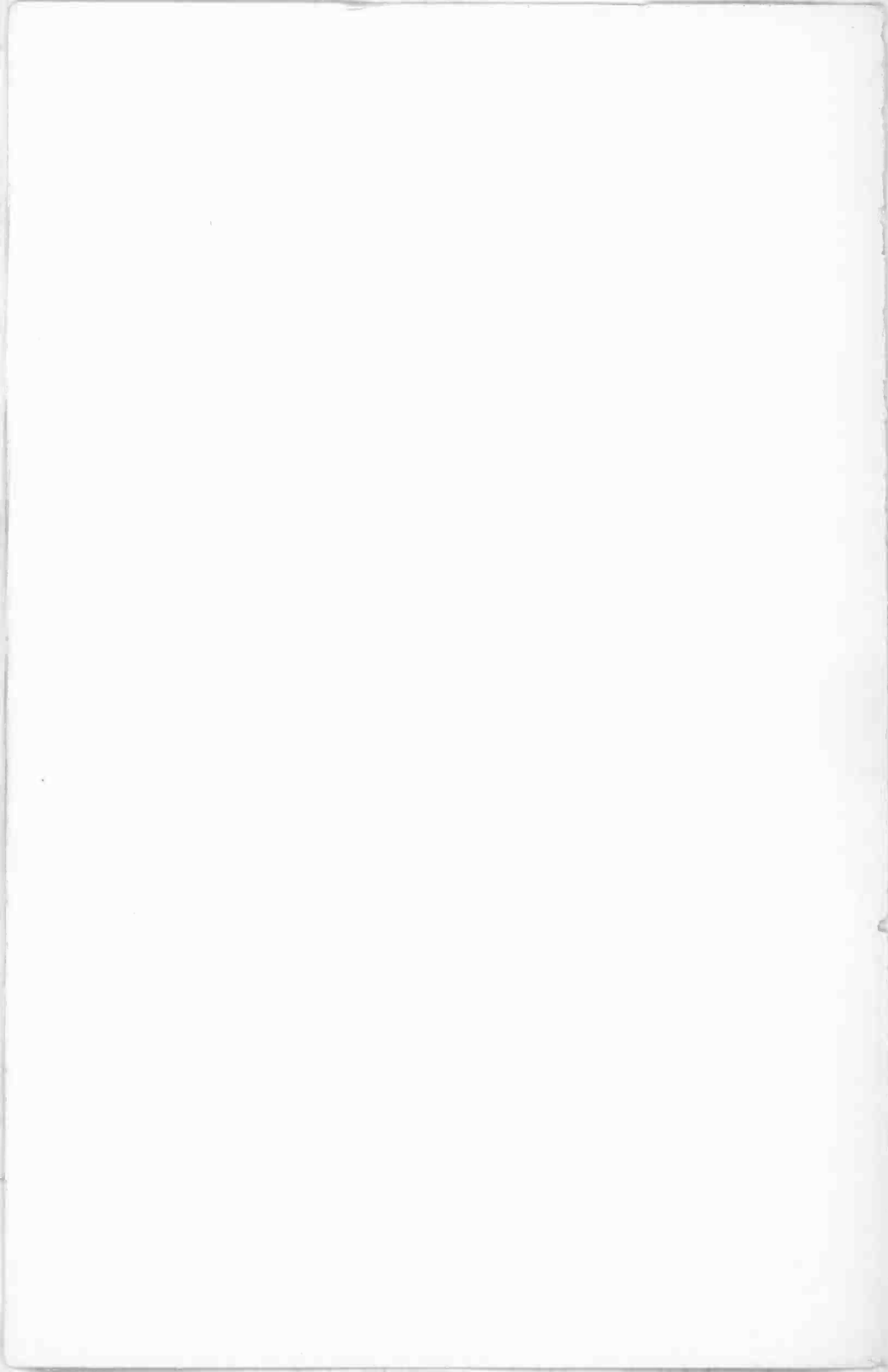



## LESSON RRT-7

# PHONO PICKUPS AND RECORD CHANGERS

### CHRONOLOGICAL HISTORY OF RADIO AND TELEVISION DEVELOPMENTS

- 1887—Heinrich Hertz. German Physicist, discovered the photo-electric effect which forms the operating principle of the phototube.
- 1888—Hertz discovered electromagnetic waves which now form the basis for all wireless and radio communication. He also demonstrated many of the propagation characteristics of such waves.
- 1891—Edison received the first patent issued in the United States covering radio signalling between two distant points purely by induction and without the use of connecting wires.
- 1894—Prof. Pupin announced the results of his investigations in electrically tuned circuits, and obtained a number of basic patents.

**DE FOREST'S TRAINING, INC.**

2533 N. ASHLAND AVE., CHICAGO 14, ILLINOIS

# RADIO RECEPTION AND TRANSMISSION

## LESSON RRT-7

### PHONO PICKUPS AND RECORD CHANGERS

#### INDEX

Phonographs .....	Page 3
Pickup Cartridges .....	Page 4
Magnetic Pickup .....	Page 4
Moving Coil Pickup .....	Page 6
Crystal Pickup .....	Page 8
Modulated Oscillator Pickup .....	Page 9
Pickup Design Trends .....	Page 11
Pickup Circuits .....	Page 12
Phonograph Needles .....	Page 16
Scratch and Needle Noise .....	Page 18
Equalizing .....	Page 18
Wireless Record Players .....	Page 19
Automatic Record Changers .....	Page 21
Types of Record Changers .....	Page 22
Changer Functions .....	Page 23
Trip Methods .....	Page 26
Pickup Control .....	Page 26
Record Sizes .....	Page 26
Operation of Record Changers .....	Page 27
Typical Record Changer Action .....	Page 29
Remote Record Selection .....	Page 31

\* \* \* \* \*

The heights by great men reached and kept  
Were not attained by sudden flight,  
But they, while their companions slept,  
Were toiling upwards in the night.

—Longfellow

## PHONO PICKUPS AND RECORD CHANGERS

### PHONOGRAPHS

Before the advent of Broadcast Radio, the phonograph was perhaps the most popular instrument for home entertainment but, judged on the basis of present standards of fidelity, those early forms of records would not be

acceptable today. Although the methods of recording and reproduction have been almost completely changed, Thomas Edison's original system employing cylindrical wax records is still used in modern offices for the dictation and transcription of letters and



Automatic record changer installed in decorative cabinet with concert speaker for the home and recreation parlor.

Courtesy Radio Corporation of America

other similar material. The disk type of record, developed soon after Edison's cylinder, is still used in modern electric phonographs, juke boxes and for radio transcriptions.

As the magnetic wire and tape recorders were explained previously, in this lesson we will describe only the more common types of phonographs designed for disk records. In general they include three main parts, the tone arm, which carries the pickup usually in the form of a cartridge, the needle and the turntable with its driving motor. Although necessary for the reproduction of records, the audio amplifier and speaker are the same as those used in radio receivers and public address systems, therefore, in a strict sense, are not a part of the phonograph. However, the electric output of the pickup must be matched properly to the amplifier input circuits, therefore, these connections will be explained.

### PICKUP CARTRIDGES

The pickup cartridge is that part of a phonograph which converts the intelligence carried by a record groove into corresponding electrical pulses. The various cartridges in common use at the present time can be classified into four general types: (1) the magnetic, (2) the moving-coil, (3) the crystal, and (4) the modulated-oscillator.

These types differ only in the method by which the mechanical motion or vibration of the needle, caused by variations of the record groove, is converted to corresponding electric waves or pulses.

### MAGNETIC PICKUP

The operating principle of the magnetic type of phonograph pickup is illustrated in the simplified drawings of Figure 1. The magnetic flux or field is produced by a U-shaped permanent magnet, and to concentrate the lines of force, soft iron pole pieces are placed between the magnet poles. The armature is centered between these pole pieces and mounted on a pivot, with the needle attached on the lower extended end. At the upper end, the armature passes through a piece of rubber which holds it midway between the poles. Between the extensions of the poles, a coil of wire is placed around the armature, but not fastened to it.

As shown by the "N-S" arrows of Figure 1-A, with the armature in the center of the air gap, the magnetic flux will divide equally, half of it passing through the upper pair of poles and half through the lower pair of poles. Except for those parts opposite to the poles, there will be no magnetic flux in the armature. With that part of the armature which is actually in the center of the

coil considered as the core, under these conditions there will be no magnetic flux in the core of the coil. As all the flux passes straight across the space between the pole pieces, there will be practically no magnetic lines through the turns of wire which make up the winding of the coil.

When the needle is moved to the right by a variation in the record groove, as shown in Figure 1-B, the upper end of the armature will move towards the upper N pole piece. From the Lesson on Magnets and Magnetism you will remember that iron has a much lower reluctance than air, therefore, moving the needle to the

the lower S pole piece, and to the S pole of the magnet. The number of magnetic lines passing through the armature at a given instant will depend on the distance the needle is moved and the greater the movement the larger the number of lines.

In following a path from the upper left to the lower right pole piece extensions, some of the magnetic lines will not remain inside the armature, and a portion of the total flux will cut through the turns of the coil. It will be remembered that when a wire cuts through, or is cut by magnetic lines, an emf is induced in the wire.



Phonograph arm equipped with crystal pickup cartridge.

Courtesy The Astatic Corporation

right, reduces the upper left air gap, and accordingly diminishes the reluctance of the magnetic circuit. The reduced reluctance will permit some of the magnetic lines to pass from the N pole of the permanent magnet, through the upper extension of the pole piece, across the shortened gap, down through the armature, to

In the same way, when the needle is moved in the other direction, by the next alternation in the recorded groove, the armature takes the position shown in Figure 1-C. Here the air gap between the armature and the upper end of the S pole piece has been shortened and some of the magnetic lines, passing from the

N to S pole of the magnet, travel up through the armature as indicated by the arrows. The action here is the same as explained for Figure 1-B except that in the coil, the induced emf is in the opposite direction. Thus, variations of a wave which has been cut in the record groove, will cause like variations of magnetic flux through the armature. Then, as that part of the armature be-

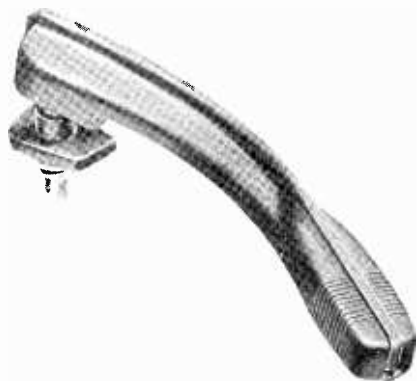

Typical phonograph pickup arm for use in electrically operated phonographs.

Courtesy Webster Electric Company, Racine

tween the arms of the poles is the core of the coil, the changing flux induces an alternating emf of like frequency in the turns of the winding. Therefore, the recorded variations are changed to electrical pulses in the coil which is connected to the input of an audio amplifier that increases the a-f signal to the level required for driving a loudspeaker.

## MOVING COIL PICKUP

While the unit of Figure 1 operates with a stationary coil and a moving or changing flux, the moving-coil type of cartridge employs a stationary flux and the lines are cut by a coil which moves in accordance with the variations in the record groove. In one arrangement of this type of pickup, illustrated in Figure 2, the coil is wound on a thin split sleeve of steel, which is mounted around one end of a short duraluminum stylus. Two thin plastic vanes, which extend at right angles to the stylus directly opposite each other, are anchored securely to the supporting bridge.

The thin edges of these vanes are placed in line with the record groove and when the needle follows the lateral excursions of the groove, the vanes flex on their center line and cause an oscillatory motion of the coil around its center. The poles of a small permanent magnet, not shown in Figure 2, are placed close to each side of the coil so that when it oscillates it cuts the lines of flux and an alternating emf is induced. As explained for the cartridge of Figure 1, here also the coil is connected to the input of an audio amplifier.

Going back to the cartridge of Figure 1, its armature has a natural resonant frequency which is determined by its density, di-



mensions, etc. When the record groove causes it to vibrate at or near this resonant frequency, its motion increases and produces an abnormal increase in the induced emf. In order to maintain the amplitude of the armature vibrations more closely to the variations of the record groove, some type of mechanical damping is necessary. This is one of the functions of the rubber bearing shown at the upper end of the armature.

vibration at all frequencies, and thus tends to reduce the overall voltage output of the unit.

The armature is made of magnetic material and its mass must be sufficiently great so that it will not be affected by the attraction of the poles of the permanent magnet. However, this results in its resonant frequency falling somewhere between 2500 and 4000 cps, which is well within

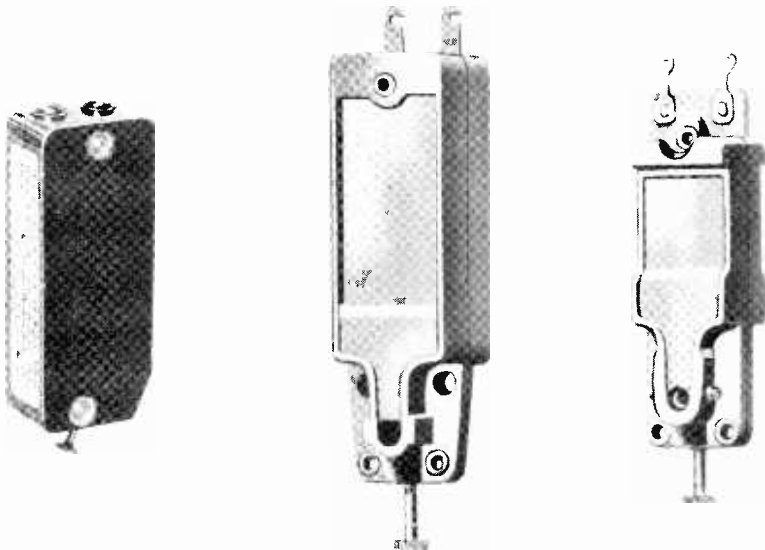

Several types of crystal pickup cartridges intended for general replacement purposes.

Courtesy The Astatic Corporation

Although this damper acts to prevent an undesired rise in pick-up output at and near the resonant frequency of the armature, it also reduces the amplitude of

the audible range. The moving-coil cartridge of Figure 2 has an advantage in this respect, in that the coil is non-magnetic and will not be affected by the poles of the

permanent magnet. Therefore the mass of the coil assembly can be reduced to a value sufficiently low to place its resonant frequency above the range of audio frequencies on the ordinary records.

In the case of the particular design illustrated in Figure 2, the resonant frequency of the unit is on the order of 12,000 to 15,000 cps, being determined mainly by the mass of the tiny diamond tip of the needle. Only a very small amount of mechanical damping is required, and consequently the voltage output over the entire range is not greatly affected by the damping action.

### CRYSTAL PICKUP

At present, the crystal cartridge is the most popular type because of its comparatively high output, good fidelity, and simple connections to the audio amplifier input. This type of pickup employs a bimorph crystal element that, due to its piezoelectric properties, generates a voltage when twisted. The action is the same but in reverse to that explained previously for a crystal type recorder.

In Figure 3 a side view of a crystal cartridge assembly is shown at A, and a bottom view with one side of the case removed at B. The crystal is attached to the needle assembly through a

damping mechanism which controls the frequency response. Lateral movements of the needle, due to the undulations of the record groove, cause the bimorph element to be twisted in accordance with the recorded sound wave, and the resulting emf, available at the terminals, is applied to the input of an audio amplifier.

Most pickups of this type employ Rochelle Salt crystals which will not withstand exposure to high temperatures (above 125° F) for long periods of time. For cases where it is necessary to operate at elevated temperatures, a crystal unit known as the "PN" type has been developed.

The output of the PN crystal is only about one-tenth that of a Rochelle Salt crystal, therefore, as will be explained, the use of higher load resistors is required for equivalent low frequency response. For this reason, the PN cartridge should never be used in circuits designed for Rochelle Salt cartridges. In fact, it is not generally advisable to replace any crystal cartridge with a type other than a duplicate of the original or one recommended by the manufacturer of the phonograph. While different units may be identical in their mounting dimensions, they usually have different frequency response characteristics, requiring different

load values and different recommended needle pressures.

### MODULATED OSCILLATOR PICKUP

In one type of modulated-oscillator pickup, the cartridge is actually part of the tank circuit of a high-frequency oscillator. The vibrations of the needle are made to cause variations in the oscillator frequency, and the resulting frequency modulated out-

recorded sound waves in the grooves of the phonograph record.

This type of cartridge, illustrated in the drawing of Figure 4A, employs a metal needle with a sapphire tip. This type of tip increases the playing life of the needle, which as a part of the electrical circuit, should not require replacement any more often than is absolutely necessary. The upper end of the needle is ground

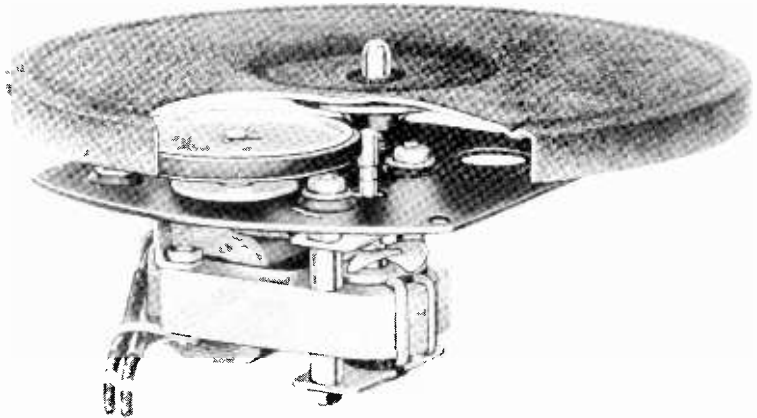

Phonograph turntable with cutaway view showing driving motor and rim-drive pulley.

Courtesy The General Industries Company

put is then detected and applied to an audio amplifier. Thus, the final electrical signal corresponds to the frequency variations of the oscillator which, in turn, correspond to the frequency, amplitude, and waveform of the re-

to a fine point and is pressed upward into a conical socket. This arrangement serves the double purpose of providing a mechanical pivot of microscopic size so that the needle is free to move easily in a horizontal direction,

and making an electrical contact between the needle and the socket. The needle is held in place by a soft rubber disk mounted in the bottom of the pickup head.

Connected in the tank circuit of a high-frequency oscillator, this cartridge acts as a variable condenser, one plate of which is made up of the case of the pickup head and the outer conductor. The other condenser plate is made

and pickup electrode which is mounted on the inside wall of the case.

This adjustment, and the relative positions of the needle and pickup electrode can be seen better in the top view of Figure 4B. Each plate of the pickup head condenser is connected to one end of an oscillator tank coil, and, therefore, any change in the capacitance of the condenser results in



Dual-speed automatic record changer. Plays either standard 78 or  $33\frac{1}{3}$  rpm, or microgroove  $33\frac{1}{3}$  rpm records.

Courtesy Webster-Chicago Corporation

up of the needle, the needle socket, and the inner conductor, all of which are insulated electrically from the elements making up the first plate. The capacitance is determined by the adjustment of the spacing between the needle

a corresponding change in the frequency of the oscillator. With no other changes, the capacitance of a condenser depends upon the distance between its plates, therefore the capacitance of this cartridge will vary when the needle

follows the undulations of the record groove and moves alternately nearer to and farther from the pickup electrode. Thus, the oscillator is frequency modulated by the recorded audio frequencies.

As has been mentioned, in order to obtain a mechanical resonance frequency above the audio range, it is desirable to reduce the mass of the moving part of a phonograph pickup to as low a value as possible. This has been accomplished in the cartridge of Figure 4 as the very light weight needle is the only part that moves. Hence, the mechanical resonant frequency of this unit is well above that of the highest audio note to be reproduced, to provide a flat frequency response over the reproduced band.

In the Zenith "cobra" a-m pickup, a coil in the cartridge forms the inductance element in the tank circuit of a high-frequency oscillator and the needle is attached to a stainless steel vane which is mounted near the coil. As the movement of the needle brings the vane closer, the  $Q$  of the coil is decreased, and the strength or amplitude of the oscillations is reduced. As the needle moves the vane away, the  $Q$  of the coil becomes higher and the strength of the oscillations is increased. In this way, the amplitude of the output of the high-frequency oscillator is varied in

accordance with the movements of the needle as it follows the undulations in the record groove.

As in the f-m system above, the amplitude modulated output of the oscillator is applied to a detector, the a-f signal output of which is then fed to an audio amplifier. Similar to the device shown in Figure 4, the only moving parts in the unit just explained are the needle and the very light vane, and again the mechanical resonance frequency of the system is well above the audio range employed in disk recording.

### PICKUP DESIGN TRENDS

As is true with practically everything we use, constant effort is being exerted toward the improvement of phonograph pickups. An example of recent development work in this line is the RCA design called the Vibratron.

Before offering a brief explanation of this unit, it may be well to mention that some detrimental effect in a receiver or amplifier may be put to good advantage in other devices. For example, in some types of vacuum tubes the electrode construction is such that a jar or mechanical vibration causes a change in the linear distance between the various electrodes. When the tube is in operation, the movement of the electrodes controls the strength

of the plate current at the frequency of the vibrations to cause a "howl" in the speaker and the tube is said to be "microphonic".

This action is utilized in the Vibration pickup, by mechanically coupling the needle to the plate of a tiny triode vacuum tube. The extended electrode of the plate then acts as a lever arrangement and audio-frequency vibrations of the needle cause corresponding changes in distance between the plate and cathode. Thus, the plate current in the output circuit varies at these audio frequencies, and can be amplified in the conventional manner.

Another type of pickup cartridge introduced recently, employs a resistive element in a voltage divider circuit. One such arrangement uses an element made of a special, high-resistance rubber conductor supported at both ends, while the needle is fastened to its center. As it follows the record groove, the needle moves from side to side causing the rubber conductor to alternately stretch on one side while contracting on the other, and then stretch on the second side while contracting on the first.

As the rubber conductor is stretched, its electrical resistance increases and to utilize this action, the entire conductor is connected across a d-c supply. With

the needle at the center, the conductor can be considered as two series connected resistors and the voltage drop across each will vary with its resistance. Therefore, the d-c voltage division between the two halves of the rubber is controlled by the audio-frequency movement of the needle. The changing or pulsating d-c voltage across one half of the divider is applied to the input of an audio amplifier the same as for other types of pickups.

### PICKUP CIRCUITS

Due to their inherent characteristics, the main types of pickups require different coupling circuits, the three most common of which are shown in Figure 5. In Figure 5A, the magnetic pickup P is coupled through the transformer T to the amplifier tube V. Though the coils of magnetic pickups may be wound with various numbers of turns, and their impedances commonly range from about 30 to 2000 ohms or more, usually the impedance of the amplifier input tube grid circuit is much higher. Therefore, to match these impedances, a transformer with the proper turns ratio is needed.

The use of a transformer to match circuit components of different impedances has been mentioned in an earlier lesson in connection with audio amplifier

output circuits. Reviewing briefly, it has been found that to obtain a maximum transfer of energy from one component to another (from a power generator to a load), it is necessary that the coupling circuit be such that on looking from the generator, the load appears to have the same impedance as the generator; and on looking from the load, the generator appears to have the same impedance as the load. This effect can be accomplished with a coupling transformer having the proper turns ratio even though there may be a considerable difference between the impedances of the components to be connected.

Though its complete derivation is rather involved, the relationship between the turns ratio of a matching transformer and the impedances of the elements which it is desired to couple, is given by the simple equation,

$$N^2 = \frac{Z_s}{Z_p}$$

when

$N$  = turns ratio

$Z_p$  = impedance of the component to be connected to the transformer primary

$Z_s$  = impedance of the component to be connected to the transformer secondary

As an example of the application of this formula, assume that it is necessary to find the turns ratio needed to match a pickup with an impedance of 100 ohms to a grid impedance of 100,000 ohms

in a circuit like that of Figure 5A. On substituting these values in the equation, the proper turns ratio is:

$$N^2 = \frac{100,000}{100} = 1000$$

$$N = \sqrt{1000} = 31.6$$

Impedance matching transformers provide maximum transfer of energy and will be found in most types of radio and other electronic equipment.

The comparatively simple connections of the crystal-type cartridge are shown in Figure 5B where the pickup output terminals are connected directly across the grid resistor  $R$ , which also serves as the volume control for the amplifier. Though the connections are simple, here the problem lies in the choice of the proper value for resistor  $R$ .

Electrically, a crystal pickup is the equivalent of a zero-impedance generator in series with a capacitance. In Figure 5B, the cartridge  $P$  represents this generator, and the condenser  $C_i$  (in dotted lines), the series capacitance. In the case of Rochelle Salt crystals,  $C_i$  has a value of about 1500 mmfd, and therefore, the pickup impedance is quite high, about 100,000 ohms at 1000 cps, and one megohm at 100 cps. Because of its capacitive nature, the impedance of the crystal cartridge increases as the frequency of the recorded signal decreases.

Rather than a power generator, the crystal pickup may be thought of as a voltage generator which requires that its load have many times the impedance of the crystal, so that the greatest part of the generated voltage will appear across the load. That is, in Figure 5B, the resistance of  $R$  must be much greater than the reactance

will determine the choice of load resistance value to be used.

The effect of various values of load resistance used with a typical high-quality crystal pickup is shown by the response curves of Figure 6. Below about 2000 cps there is a general increase in output for all values of  $R$ ; but as the lower frequencies are reached,

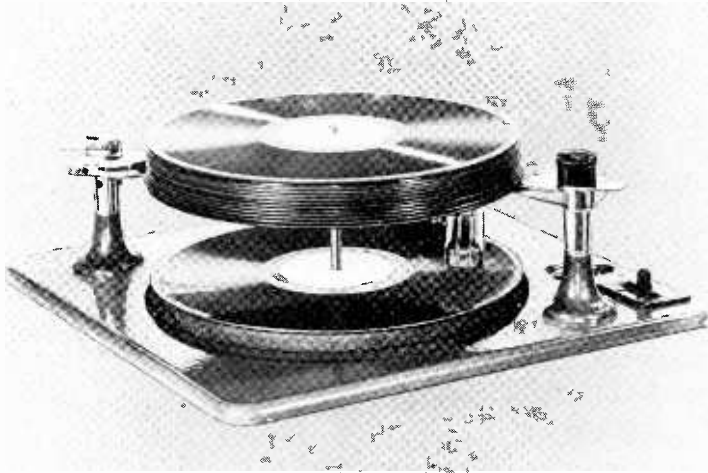

Dual-past automatic record changer showing the knife or slicer mechanism for dropping the bottom record to the turntable.

Courtesy J. P. Seeburg Corporation, Chicago

of  $C_t$ , so that most of the pickup voltage output appears across  $R$  and is available for application to the grid of the amplifier tube  $V$ . Since the impedance of this pickup is highest at the lowest frequencies to be reproduced, the desired low frequency response

the response drops off again in each case, the greatest drop-off occurring with the lowest value of  $R$ . In other words, to prevent this low-frequency drop-off in pickup circuit response, it is necessary to use a comparatively high value of load resistance.



Experience has shown that for home reproduction with amplifiers having good speakers, most listeners prefer the elevated bass response obtained with values of R of 0.5 megohm or more. However, if the amplifier has only a small speaker, the increased bass response is likely to result in distortion due to excessive speaker stiffness and poor radiating ability at low frequencies. In such cases, a somewhat lower value of load resistance, such as 0.25 or 0.1 megohm, gives better results.

The capacitance of a PN crystal is only about one-tenth that of the Rochelle Salt variety, and therefore, to obtain equivalent bass response, much higher value load resistors are needed, possibly as high as 50 megohms. This is the reason the two types of crystal cartridges are not interchangeable, unless the necessary change in load resistor is made also.

At this point we want to emphasize the importance of charts which indicate the frequency response of a device. While Figure 6 is drawn to indicate variations in relative output for a pickup circuit over the audio frequency band, similar data can be shown for loudspeakers, audio amplifiers and microphones. In general, an ideal frequency response curve is relatively flat over the full range of operation and represents uniform output, without resonant effects.

The connections between the oscillator tank circuit and the pickup explained for Figure 4 are shown in Figure 5C. Here, tube V is connected as a tuned-grid oscillator with tank inductance L tuned by the capacitance of the cartridge P in parallel with trimmer C<sub>1</sub>. As mentioned above, in this arrangement the pickup is actually a part of the electrical circuit of the oscillator, and therefore, no coupling or impedance matching unit is required.

Unlike the other types of pickups, the output of the circuit of Figure 5C is modulated r-f, similar to the modulated carrier radiated by a broadcast station. Therefore, by means of trimmer condenser C<sub>1</sub>, the oscillator is tuned to some carrier frequency at which no other signals are heard and is then tuned in on a radio receiver in the same way as other broadcast stations.

For the other types of pickups, the output is at audio frequency and therefore, as shown in Figure 7, connections are made in the detector circuit of a radio receiver. In the conventional radio-phonograph combinations, the circuits are installed so that the panel operated "Radio-Phono" switch connects the audio amplifier input to either the output of the detector tube or the phonograph pickup. Many models of radio receivers are equipped with a phono jack or terminal so that

the audio amplifier can be used for the reproduction of records, if a phonograph is available.

It must be remembered that the output of the average radio detector is much greater than that of some later types of high fidelity pickups. Therefore, in some cases,

## PHONOGRAPH NEEDLES

The needle, or rather the needle point, is one of the most important parts of the complete pickup, as it has a great effect on the quality of reproduction and wear of the record. We want to emphasize this fact because, while



Home record player equipped with automatic record changer and 3-tube push-pull amplifier.

Courtesy Tele-tone Radio Company

it may be necessary to install a pre-amplifier between the pickup and the input of the audio amplifier of a radio receiver or public address system.

the needles are small and inexpensive, their importance may be overlooked.

There are three general factors to consider in the selection of a

pickup needle: First, it must be the correct shape to fit the needle holder of the cartridge and its point should match perfectly with the record groove. Second, its point should have and retain a high polish to prevent scoring or damaging the walls of the record groove. Third, it should be long wearing and capable of retaining its manufactured shape.

According to the material of which they are made, needles are classed as metal, fibre, and jewel. The metal needles are steel, chromium and rare-metal alloys; the fibre needles are of cactus or thorn; and the jewel needles have diamond or sapphire tips.

Though most expensive, the jewel needle is the best type available, since it not only has a good frequency response, but retains its shape for a long time, thus causing a minimum of record wear. Various available types are rated to be good for from 1000 to 10,000 plays.

The fibre needles are the next best type as far as record wear and playing life is concerned, since they may be resharpened a number of times and will play from eight to ten record sides after each resharpening. However, their frequency response is perhaps the poorest of all types, and becomes worse as the needle point dulls with wear.

The steel needle has better frequency response than the fibre type, however, the steel point wears rather quickly and soon forms a cutting edge which causes excessive record wear. For this reason and in order to preserve the quality of the recordings, a steel needle should not be used to play more than one record side. If steel needles must be employed, it is far cheaper to use a new one for each playing than to ruin a set of records by economizing on the number of needles used. Due to their extremely short life, steel needles cannot be used with the automatic record changer type phonographs.

Chromium needles have about the best frequency response of metallic types. Also, since they are good for about 24 record sides per needle, their employment in record changers is permissible. They have a drawback, however, in that whenever their plating is not uniform, uneven needle wear results and produces an excessive amount of record wear.

Summing up, the metallic types of phono needles are generally least expensive, have fair frequency response, the shortest life, and cause most record wear; while the jewel types cause least record wear, have the best frequency response, the longest life, and are the most expensive.

## SCRATCH AND NEEDLE NOISE

Because of undesirable movements of the pickup needle, due to the texture of the material of which the record is made, certain generated voltages manifest themselves in the phono output as an undesirable high-frequency hiss or scratch, sometimes called needle noise. In certain cases, the greatest part of this noise seems to be localized in the frequency region between 4500 to 5000 cycles, and can be reduced by means of a "scratch filter".

This unit consists of a series LC circuit connected from the input amplifier tube grid to ground as shown in Figure 8. Here, the filter elements L and C are tuned to some intermediate frequency such as 4700 cycles, and at this frequency, form a low impedance path to ground. The amount of attenuation, or effect of the filter, may be adjusted by means of the variable resistor R, in series with L and C.

However, in most cases surface noise frequencies are randomly distributed throughout the entire audio band, and thus cannot be reduced by means of the narrow band elimination method of Figure 8. This scratch noise can be reduced somewhat by the use of needles (cactus, bamboo, etc.) whose response drops off earlier at the high frequency end

of the band, or by means of adjustment of the audio amplifier tone control. However, both of these methods result in a corresponding reduction of tone quality and fidelity. The most satisfactory reduction in needle scratch is being brought about by the development of new record materials and other phonograph design improvements.

## EQUALIZING

To reduce the large amount of scratch noise inherent in older types of phono outputs, most people are in the habit of adjusting the amplifier tone control so that severe attenuation of the high frequencies is produced. In general, people have grown so accustomed to the resulting excessive bass response, that they now actually prefer this unnatural tone quality to that produced by a system having an overall flat frequency response.

However, should high-quality music be desired, the overall response of the system can be flattened by the insertion of a simple parallel RC circuit as shown in Figure 9. Having an impedance which rises as the frequency decreases, this circuit is called an "equalizer", and also acts to attenuate the low frequencies somewhat, thus reducing their amplitude to approximately that of the highs. By varying the

setting of R, the response can be adjusted all the way from unequalized (with  $R = \text{zero}$ ) to fully equalized ( $R = \text{maximum}$ ) as desired.

### WIRELESS RECORD PLAYERS

Probably one of the most important factors contributing to the popularity of wireless record players is the fact that they play through a radio without any di-

through his radio from a distance of many miles compared to the distance of a few feet separating the wireless phono from the receiving set. Actually, the wireless record player is a simplified miniature radio transmitter.

A second and more practical advantage of this type of phonograph is that it may be placed at any convenient location, or moved from one point to another at will, the location being limited only by



Capehart Model P-70 record changer, plays 10" or 12" records intermixed. Records are supported on spindle, and nothing touches the edges or surface.

Courtesy Farnsworth Radio & Television Corporation

rect connection being made. To the layman this seems quite mysterious, hence his interest is aroused. In fact, he sometimes seems more amazed by this than by the fact that the radio broadcast stations which operate on exactly the same principle, play

the maximum distance from the receiver at which satisfactory operation can be obtained and by the convenience of an a-c power outlet.

As an example of the type of circuits employed, the schematic

diagram of a Wilcox-Gay wireless record player is given in Figure 10. Besides the components shown here, the complete phonograph includes a rectifier to supply d-c power to the tube V, a turntable, and a phono-motor. Tube V performs the double function of r-f signal generator (oscillator) and modulator. For the first function,

circuit while resistor  $R_b$ , with condenser  $C_b$ , provide grid-leak bias for the oscillator grid. The generated r-f signal is coupled from the upper end of  $L_1$ , through condenser  $C_c$ , to the antenna which consists merely of a short piece of wire. The r-f energy radiated into space from this antenna may be tuned in by a radio receiver in

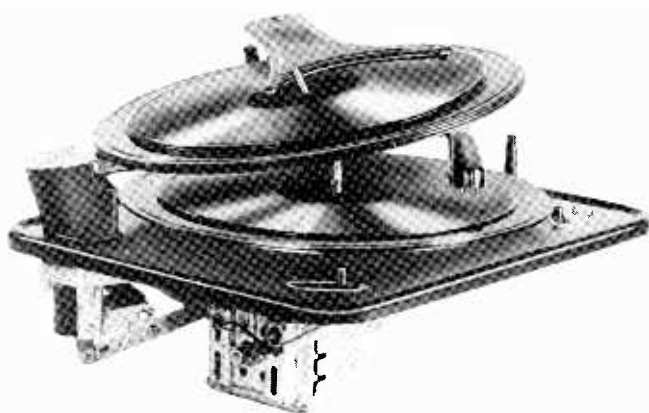

Garrard Model RC65 deluxe record changer. Will accommodate 10" and 12" records intermixed. Has speed-controlled motor at 78 rpm, and automatic stop on last record.

Courtesy Garrard Sales Corporation

the cathode, the fourth grid, and the plate form the elements of a tuned-grid oscillator. The tank circuit of grid coil  $L_1$  and condenser  $C_1$  is resonant at a frequency somewhere in the low end of the broadcast band, and is tunable over a small range. The feedback coil  $L_2$  is in the plate

the same way as the carrier transmitted by a broadcast station.

The pickup P generates the audio signal which, applied to the first grid of V, causes the plate current to vary in accordance with the audio frequencies, at the

same time that it is pulsating at the rate of the oscillations in the  $L_1 C_1$  tank circuit. Thus the a-f and r-f signals are mixed in such a way that the radiated r-f energy carries the audio variations from this transmitter to the radio receiver. This mixing process, called modulation, is taken up in detail in later lessons. When the receiver is tuned to the frequency of the phono-oscillator, its output will be received, detected, amplified, and applied to the speaker in exactly the same manner as any radio program.

As all radiation at radio frequencies is under strict control of the Federal Communications Commission (F.C.C.), certain rules have been set up to permit the operation of this type of circuit without violating existing laws. The maximum legal radiation distance can be calculated by the formula,

$$\text{Distance} = \frac{157,000}{\text{kc}} \text{ ft.}$$

For example, if condenser  $C_1$  of Figure 10 were set to produce an oscillator frequency of 600 kc, then substituting in the formula,

$$\text{Distance} = \frac{157,000}{600} = 261 \text{ ft.}$$

Thus, operating under these conditions, the antenna and the power output of the circuit must be adjusted so that the signals can not be picked up or cause in-

terference in receivers located more than 261 ft. distant. For normal use, the receiver will seldom be located more than 25 to 30 feet from the oscillator, and therefore the rule does not interfere with the intended purpose of the unit.

By replacing the pickup with a microphone, speech or music picked up by the microphone will be amplified and heard in the speaker of the receiver. This plan is followed at times to utilize an available radio receiver as a public address amplifier.

### AUTOMATIC RECORD CHANGERS

Most modern radio-phonograph models include an automatic record changer to provide longer recorded programs without attention by the operator. As the operation of the changer is entirely mechanical, many radio men have avoided any responsibility in regard to its adjustment or maintenance. However, from the owner's standpoint, the changer is an integral part of his radio-phonograph and, as such, should be serviced the same as any other parts. Thus, it is important that the radio man have a basic knowledge of the problems involved in the operation of record changers, even though these problems are concerned almost entirely with mechanical actions.

It is desirable, that the radio man be familiar with each of the several types of changers although of the more than two dozen manufacturers, many of whom make several models, no two seem to agree exactly on how a record changer should operate. However, regardless of the details of its operation, every changer must accomplish essentially the same functions, that is: (1) support the unplayed records, (2) select the next record to be played, and (3) properly handle the pickup arm during the "change-cycle".

When considered from this more general point of view, the action is greatly simplified. Knowing the nature and sequence of the various jobs which every changer performs, any given unit may be checked quickly to see which of the operations is not being accomplished properly. Then by visual inspection, or with the aid of the manufacturer's service data, the details of the improper action can be examined to locate the source of whatever trouble may exist.

### TYPES OF RECORD CHANGERS

In general, record changers are classified according to the method by which they handle the records during the change cycle, although a number of other actions take place at the same time, the most

obvious of which is the movement of the pickup arm. On this basis there are four main types.

1. The most popular type operates on what is known as the drop system, whereby the stack of unplayed records is held above the turntable, and during the change cycle, the bottom record is allowed to slide down the spindle to the turntable.

2. The "ejector" or "throw-off" type of changer in which the unplayed stack of records rides on the turntable, and when the top record has finished playing, it is pushed off the turntable into a hopper.

3. The "turn-over" type of record changer in which the records to be played are stacked horizontally in a hopper which turns up on end when a record is to be selected. Upon reaching a diagonal position, the bottom record slides out upon the turntable, while the other records are held in place by a frame which has moved up from its normal position surrounding the turntable.

At the end of the playing cycle, the stack is again upended, and the record, picked up from the table, is carried to the hopper where it is held for an instant. Then, as the stack tilts slightly, the record is again allowed to slide onto the turntable, this time with the unplayed side on top. After the second side is played,



the record is lifted and placed upon the top of the stack and the next record slides out from the bottom onto the turntable.

4. A combination of the drop and ejector types which plays both sides of the records has a small turntable equal in diameter to the blank center area of the record. Like the drop type, the

reverses and the lower pickup plays the bottom side. After both sides have been played, the turntable tilts and the record slides off into a receptacle located beneath the motorboard. Two motors are employed, one to operate the turntable and the other the various mechanisms which change the records, move the pickup, etc.



Single-speed 78 rpm record changer, well suited for original installations or replacement purposes.

Courtesy Webster-Chicago Corporation

stack is located above the turntable but the tone arm has two separate pickups, one of which is mounted upside-down. The upper pickup plays the top side of record, and when this is finished, the direction of turntable rotation

## CHANGER FUNCTIONS

The drop type of changers may be classified according to the method by which the unplayed stack of records is supported. Some models employ two and others three posts to support the

records at the outer edge. Another type supports the stack by means of a single post and an offset ledge on the spindle, while in still another type, the records rest on the spindle only, with an arm extending from a side post for the purpose of balancing the stack.

Individual designs employ various combinations of these systems. For instance, an advantage of the three-post system is that the record is more likely to drop perfectly flat when released simultaneously from the three posts.

The Farnsworth Model P-51 drops records as a three-post mechanism, although the stack normally rests only on one post and the spindle.

Most two and three-post changers employ the knife or "slicer" method, wherein the record stack rests on shelves which rotate out from beneath the stack during the change cycle. As the shelves turn outward, knives enter between the two lower records to allow the bottom one to drop to the turntable, while supporting the remainder of the



Capehart Model 41E record changer. Continuously and automatically plays up to 16 records, 10" and 12" intermixed, on one side only or on alternate sides in sequence. Provides nearly three hours of uninterrupted performance.

Courtesy Farnsworth Radio & Television Corporation

stack until the shelves move back to their normal position.

Adjusted to touch the edge of the bottom record, the knife blades rotate with the shelves but as records vary in thickness, they are free to move upward. Thus, as they rotate with the shelves, the knives contact the rounded edge of the bottom record and move up sufficiently to slide in between it and the record above.

A disadvantage of this system is that if the bottom record is too thick or the slicer adjustment too low, the blade may jam against the edge of the record instead of sliding up over it. In the same way, if the bottom record is too thin or the slider adjustment too high, the blade may jam against the edge of the second record from the bottom. In either case, the blade may bend, the record may break or the changer mechanism may stop. Although of proper thickness, a warped record may cause the blades to jam.

The single post and postless changers, as well as some two-post types, employ what is known as the pusher method of record selection. In these the spindle performs the actual selection, while the pusher mechanism merely moves the record off its supporting shelves so it can drop to the turntable. The spindle of one such changer is shown in Figure 11A where the records are

stacked on the upper offset section, with the bottom record resting on the shelf S. The space between this shelf and the lower edge of the upper portion of the spindle is just large enough to accommodate one record.

The pusher mechanism is mounted on a post located at the outer edge of the stack and when it moves the lower record to the right in Figure 11A, the upper part of the spindle holds the other records in place. The lower record moves over until its central hole is in alignment with the lower part of the spindle when it drops to the turntable and the next record moves down onto the shelf.

The spindle illustrated in Figures 11B and 11C performs both the selecting and pushing functions by means of an eccentric, or cam between its upper and lower sections. While a record is being played, the eccentric is in the position shown in Figure 11B and the stack is supported as in Figure 11A. During the change cycle, the eccentric rotates and when it reaches the position of Figure 11C, the bottom record of the stack drops down over it. As its rotation continues, the eccentric reaches the position of Figure 11B and allows the record to drop onto the turntable, while still supporting the stack above.

With most pusher type changers, the spindle does not rotate

with the turntable, and sometimes a squeak is caused by the records on the revolving turntable rubbing on the stationary spindle. A thin coating of wax, placed on the spindle, will reduce the noise and also the wear on the center holes of the records.

### TRIP METHODS

The different makes of automatic record changers employ various trip methods by which the change cycle is set in motion at the end of a record. In one system, called the "position trip", a lever connected to the pickup starts the change mechanism when the needle reaches a predetermined point, such as  $1\frac{7}{8}$ " from the spindle. In other systems, the tripping action is caused by the motion of the pickup when the needle is in the lead out to the stopping groove, or in the eccentric stopping groove itself in the central blank area of the record.

### PICKUP CONTROL

As for the other functions, in the handling of the pickup arm there is much variation between the different makes and models of record changers. The arrangement most frequently encountered consists of a large cam which has an indentation in which the pickup arm lift pin rests during the playing period. When the change mechanism is tripped, the cam begins to rotate and an eccentric

groove on its top surface guides the lift pin so that the pickup arm is lifted off the record and made to swing out clear of the turntable while the new record is dropped. Still following the groove, the lift pin guides the pickup arm back to the edge of the record and then lets it down onto the playing surface as it once more comes to rest in the indentation in the cam.

Another type of change mechanism consists of an assembly which slides along a pair of guide rods located beneath the turntable. As the slide moves out toward the edge of the turntable, it engages the lift pin which raises the pickup arm from the record. Then the pin is turned to swing the pickup outward, and the record ejector pushes the lower record from the stack. Next, the slide moves back to its normal position permitting the arm to be brought to its set-down point, and finally to be lowered on the record.

### RECORD SIZES

As most changers are designed for either 10 inch or 12 inch records, some means must be provided to adjust the mechanism to handle the size of record to be played. Usually all the records in a given stack must be of the same size, in which case some manual adjustment can be made. In other models, the set-down point of the pickup is determined by a mech-

anism which is tripped only by the 12 inch records while they are on the support shelves, or as they fall to the turntable.

In the Zenith Model S-11860, a trip lever, mounted near the turntable, is struck by a 12 inch record as it drops thereby causing the

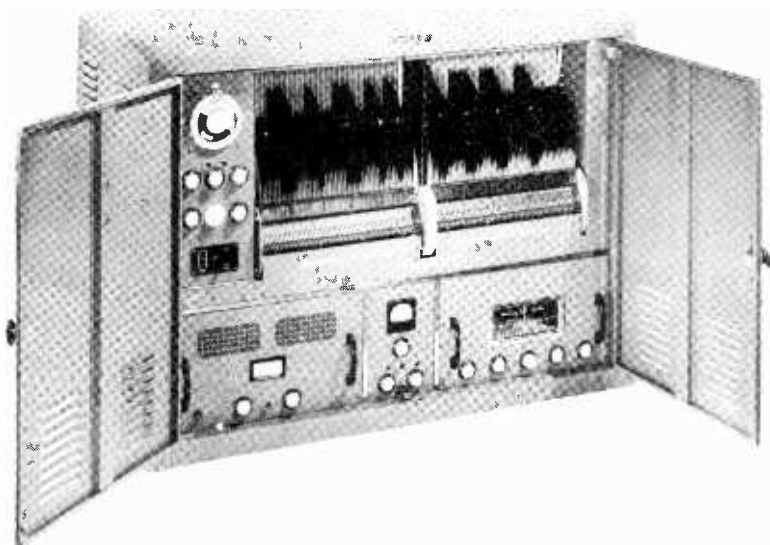

Seeburg Industrial & Commercial Unit for selecting and reproducing any one of a group of one hundred records.

Courtesy J. P. Seeburg Corporation

A few types of record changers will operate with intermixed record sizes. For example, in the Seeburg Model M, one of the support posts contains a tiny button which will be pressed when the bottom record is 12 inches in diameter, but which will be free in the case of a 10 inch record. When this button is depressed, the mechanism which controls the pickup arm operates so as to lower it at the outer or 12 inch set-down point.

mechanism to set the pickup down at the proper point. When a 10-inch record falls, it misses this lever and the pickup is set down at the inner or 10 inch position.

### OPERATION OF RECORD CHANGERS

Since every make and model of record changer operates in its own particular manner, it will not be possible to describe the action of each one in this lesson; however, as mentioned above, the

change cycle is usually described in the manufacturer's service data furnished with each particular unit. When this data is not available, the action of any particular changer can be checked by placing it so that the parts

As may be imagined, to attempt to keep track of all the motions of each part during the cycle will be extremely difficult, if not impossible. In fact, the only practical manner in which the complicated record changer mech-

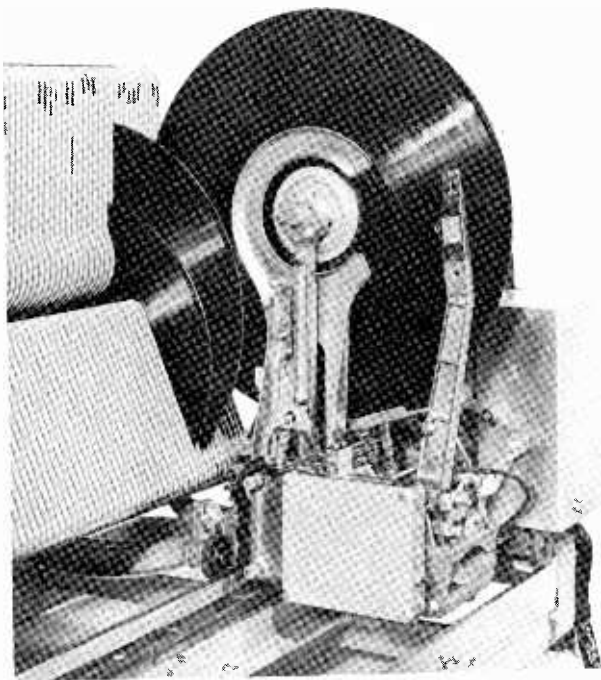

Automatic operating mechanism and pickup arm used in Seeburg Unit shown in previous illustration. Records are played in a vertical position.

Courtesy J. P. Seeburg Corporation

below the motorboard may be seen, and while turning the turntable motor slowly by hand, watching closely the motions of each part (cams, pawls, gears, linkages, etc.) as the changing mechanism goes through its cycle.

anisms can be studied, is to concentrate only on the parts concerned with one function, and then when the performance of this function is understood, go on to the next. This general method can be applied to any changer for

although differing in their methods of producing the various motions, all of them must do the same four things. These are: (1) lift the pickup from the record after it has been played, (2) move the pickup out of the way, (3) drop the next record to the turntable, and (4) place the tone arm in proper position on the new record.

Since most of the parts are not in motion during the time that a record is being played, this interval forms the logical starting point of the cycle. The first function to watch, is the action of the trip mechanism when the needle reaches the end of the record. At this point it may be well to check the action of the reject button, the pressing of which operates the tripping device at any desired instant. That it, the reject button does the same thing at any time during the playing of the record as happens when the needle reaches the last groove. With some models, the reject button must be pressed in order to start the changer operating when the first record of the stack is to be played.

The second function to watch is the method by which the pickup is lifted off the record and moved out from beneath the record stack. Third, check the method of returning the pickup to the set-down point for a 10-inch record

and lowering it to the record. After this, the mechanism which determines the pickup arm return for a 12 inch record should be noted. Finally, the operation of the components which control the dropping of the records from the stack onto the turntable may be observed.

Though this last mentioned function actually is performed before the return of the pickup to the record, it is most convenient to observe the complete pickup arm motion rather than leave it temporarily to watch the record release action and then come back to the tone arm again.

### TYPICAL RECORD CHANGER ACTION

As an example of the actions which take place in modern record changers, the motions of the various parts making up the changer mechanism in the Admiral Model RC150, are described in detail in the following paragraphs. This model employs the slide type change mechanism, and a simplified drawing showing only the main components of this unit, is given in Figure 12. As the pickup arm A moves toward the center of the turntable during the playing of a record, trip linkage assembly B turns, causing stop arm C to pull the retaining lever D away from the center post. Mounted on lever D, the retaining roller E is drawn gradually along

slot W and away from its position where it holds eccentric cam T in its between-cycle stationary position.

When the needle reaches the last groove of the record, retaining roller E is pulled free of the eccentric cam stop bracket (not shown) and spring U pulls cam T against knurled roller G, which is mounted on and turns with the turntable shaft H. This comprises the tripping action. When pushed, the reject button acts to turn stop arm C far enough so that retaining roller E releases the eccentric cam as explained above.

When it contacts the knurled roller G, cam T begins to revolve, and off center post V pushes the riser plate assembly J toward lift rod K along a pair of guide rods (not shown). As the inclined surface of the riser plate passes under its lower end, lift rod K is pushed up and raises the pickup arm off the record by means of lift adjustment screw L.

As cam T continues to rotate, the motion bracket Y pushes stop arm C outward from the center post H, thereby rotating assembly B which causes the pickup arm to swing out clear of the edge of the record stack.

The guide pin assembly N and P, which also is attached to B, rotates the push-off cam R by means of upper lift rod Q. As it

rotates, cam R pushes against the set-down point adjustment screw F and moves push-plate S toward the center post, thus pushing the edge of the bottom record off shelf X so that the record drops to the turntable.

The push-plate springs (not shown) return the push-plate to its normal position, and in so doing rotate the push-off cam. This returns trip linkage assembly B to its normal position and moves the pickup arm in to its set-down point.

Having completed a half revolution, eccentric cam T now causes riser plate assembly J to reverse its direction of travel and move back toward the center post. As the riser plate, which is propelled by a recoil spring (not shown), moves toward the center post, it allows lift rod K to drop to its normal position, and in doing so, to lower the pickup to the record.

As it continues its revolution, a ferrule on the guide rod moves the eccentric cam away from the knurled roller G, which prevents the cam-supporting bracket (not shown) from traveling any further toward the center post. The cam rotation ceases when its stop bracket comes to rest against retaining roller E. This completes the change cycle, and with the exception of the very slow movement of the trip components B,



C, D, and E (due to the pickup arm travel across the record), the elements of the change mechanism remain at rest until tripped again when the record has finished playing.

and to play his selection all the customer need do is push the proper button and insert a coin into the box.

As in the case of the record changers described above, the



Spindle-type automatic record changer used extensively in home phono-radio combinations.

Courtesy Crescent Industries, Chicago.

### REMOTE RECORD SELECTION

Many restaurants, ice cream parlors and similar establishments employ automatic record changers in which the selection of the record to be played is made by means of remote wall boxes located at various distances from the phonograph. These wall boxes are fitted with a set of push-buttons or similar selecting devices,

methods, by which the different remote record selection systems operate, vary considerably and to give you an idea of the problems involved, one type of a 12 record system is explained here. In this unit, each of the wall boxes contains an r-f oscillator followed by a one stage amplifier, the outputs of all of which are coupled to a common transmission line that leads to an input r-f amplifier located in the phonograph cabinet.

Each wall box contains a set of twelve oscillator coils, the one connected to the oscillator tube at any instant depending upon which push-button has been pushed last. Each coil has a different value of inductance so that the frequency of the oscillator output will be different for each push-button. When a coin is

at all times to the primaries of a set of twelve r-f transformers, the secondaries of which each connect to an individual detector tube. Both the primaries and secondaries of these transformers are tuned by means of parallel condensers in the same manner as the i-f transformers in a superheterodyne radio receiver.

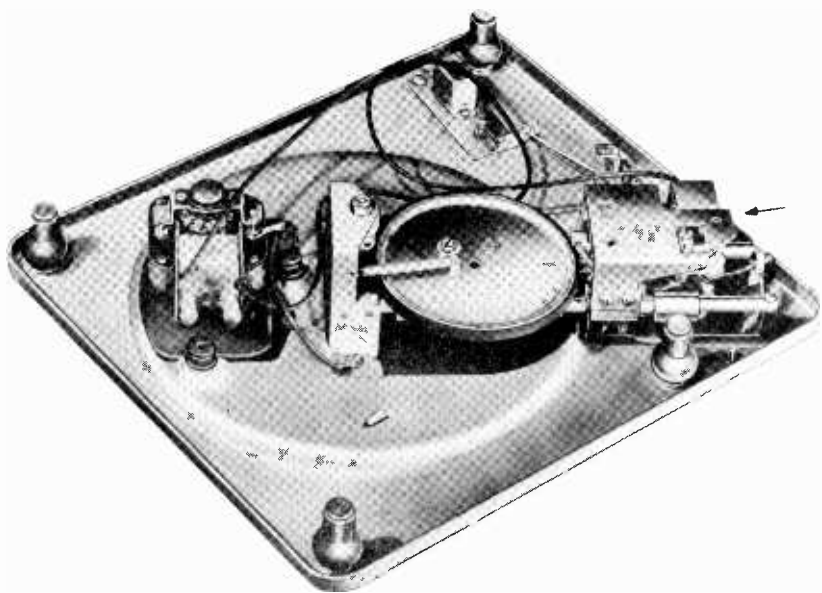

Bottom view showing operating mechanism of record changer illustrated on opposite page.

Courtesy Crescent Industries, Chicago

dropped into the slot, it momentarily closes the oscillator tube plate circuit so that a few cycles of r-f voltage are sent to the phonograph via the transmission line.

The output circuit of the phonograph r-f amplifier is connected

Each of these twelve r-f transformers is tuned to a different frequency, the values of which correspond to those that each wall box oscillator is capable of generating. The particular signal received at any instant depends upon the push-button selected at the box in which a coin has been

dropped. The spacing of the frequencies and the sharpness of tuning of the phonograph r-f transformers, are such that each transformer allows passage of only that frequency to which it is tuned.

Each tuned transformer secondary is coupled to a plate or bias type detector the average d-c plate current of which increases when a signal is applied to the grid. The plate current in the output circuit of each of the twelve detectors is made to operate the mechanical control device, so that the selection of the record depends upon which detector circuit has received a signal.

The record changer holds the stack of records vertically in a magazine. Mechanical selection of records is made automatically by sliding the record magazine along two parallel glide-rods and positioning the selected record opposite a delivery arm. The point at which the magazine stops, is determined by the particular detector circuit in which a pulse of plate current has occurred due to the reception of a signal from the oscillator in one of the wall boxes. The delivery arm then swings back and places the record in the "play ring" which holds it by its edge and turns its plane through a 90° arc, thus bringing it up to the pickup. This play ring rotates the record

under the pickup in the same way as in the ordinary turntable.

A block layout of this system is given in Figure 13 and although only eight are shown, any number of wall boxes may be connected to the transmission line. In the phonograph, the r-f amplifier, tuned transformers and detectors make up a special radio receiver the output component of which consists of the control device that operates the record magazine of the changer. The remaining units shown at the bottom of the figure, are those making up the usual automatic record player.

To summarize the action, suppose a listener decides to play the record listed as number 7 on the wall box index. He pushes button number 7, thereby connecting the proper coil to the oscillator tube to make the tank circuit resonant to frequency number 7. As his coin slides down the slot, it momentarily closes the normally open oscillator plate circuit, thereby causing the oscillator to operate for an instant, and send an r-f signal along the transmission line to the receiver at the phonograph.

In the phonograph, this signal passes through the r-f amplifier and is applied to the primaries of the twelve transformers connected to its output. However, in this case, the signal will be passed by transformer number 7, and will thus be applied to detector

number 7 only. The plate current pulse of this detector operates the control device so that the record magazine moves along the guide rods and stops when record number 7 is opposite the delivery arm, which then begins to operate as described above. When the record has finished playing, the play-ring again returns the record to a vertical position, after which it is replaced in the magazine by the delivery arm.

The signal output of the respective wall box oscillators is very

low, less than 1 volt, and therefore they cause no interference with other systems which may be in use in the vicinity. The isolating r-f amplifier stage in each of the wall boxes prevents them from interfering with one another even though they all connect to the same transmission line. The d-c power needed to operate the wall box tubes is sent from a power supply, contained in the phonograph, by means of the same transmission line that carries the r-f signals in the other direction.



Automatic record changer for 78 rpm records. Also equipped with separate pickup arm for 33 $\frac{1}{3}$  rpm long playing records.

Courtesy Admiral Corporation

**IMPORTANT WORDS USED IN THIS LESSON**

**ARMATURE**—The pivoted iron bar to which the needle is attached in a magnetic type phonograph pickup.

**COBRA PICKUP**—A form of modulated-oscillator pickup developed by the Zenith Radio Corporation.

**CRYSTAL PICKUP**—A form of phonograph pickup in which the needle (as it follows the variations in the record groove, deforms a Rochelle Salt crystal and causes it to develop corresponding voltage pulses.

**DAMPING**—Reducing or restricting the lateral motion of the moving element in a pickup.

**MAGNETIC PICKUP**—A form of phonograph pickup in which the movement of the needle varies the flux through a coil mounted between the poles of a permanent magnet, to induce corresponding voltage pulses in the coil.

**NEEDLE SCRATCH**—The noise component in the output of a phonograph pickup due to the coarse particles in the record material as well as the unwanted irregularities in the groove.

**PICKUP CARTRIDGE**—That unit at the free end of a phonograph pickup arm which converts the irregularities in the groove on a record into corresponding electrical pulses.

**SCRATCH FILTER**—A series resonant circuit usually connected across the output of a phonograph pickup to attenuate the higher frequencies and thus reduce the unpleasant effects of needle scratch.

**VIBRATRON**—A form of phonograph pickup developed by RCA in which the needle is coupled directly to the plate of a tiny triode vacuum tube, and the resulting movements of the plate cause similar variations in plate current.

**WIRELESS PHONOGRAPH**—An electric phonograph in which the phono pickup modulates an r-f oscillator that in turn feeds a small radiating antenna and thus broadcasts the signals for short distances.

# STUDENT NOTES

STUDENT NOTES

(45701)

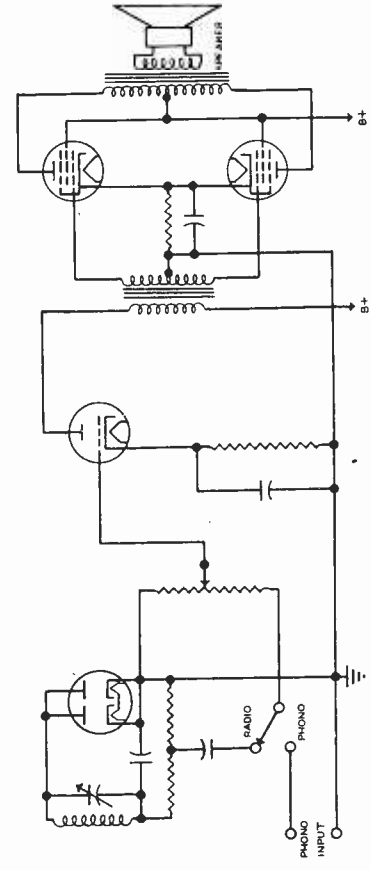

FIGURE 7

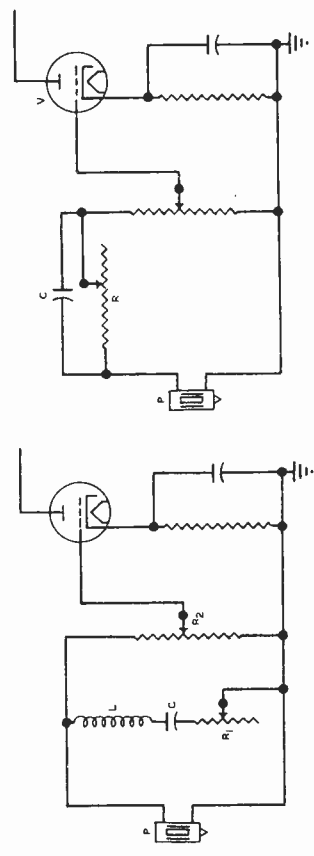

FIGURE 9

FIGURE 8

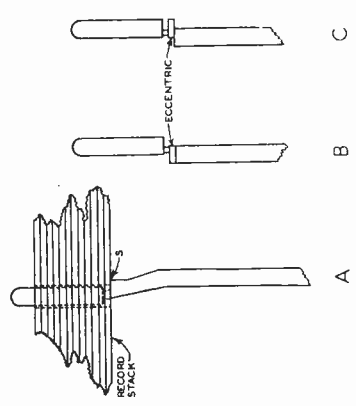

FIGURE 11

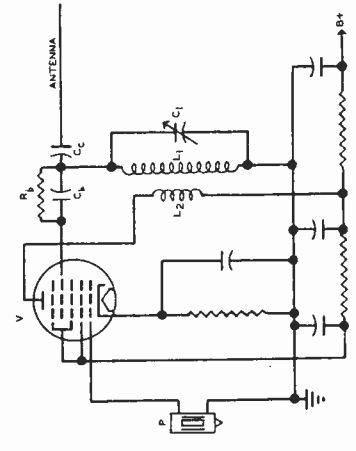

FIGURE 10

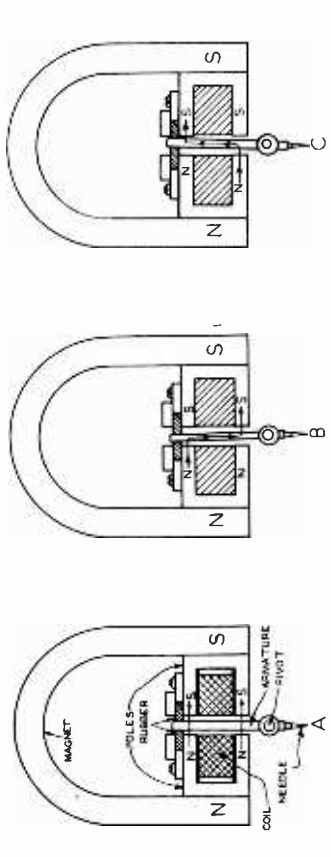

FIGURE 1

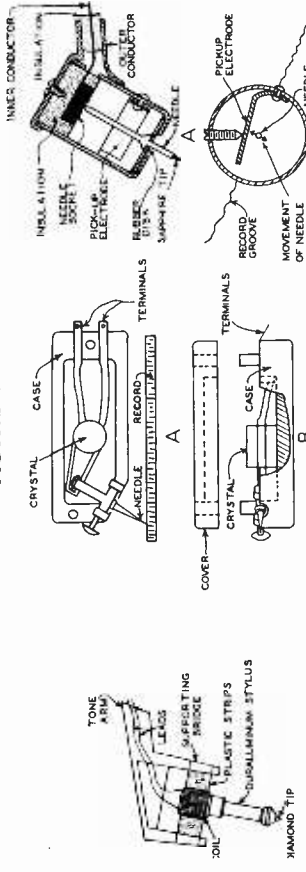

FIGURE 2

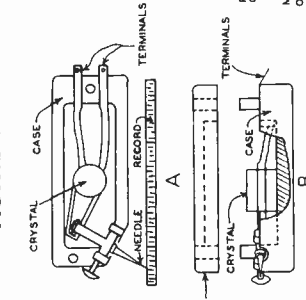

FIGURE 3

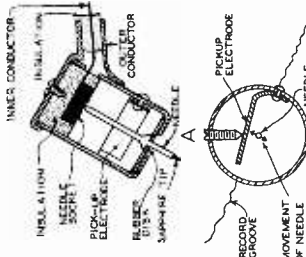

FIGURE 4

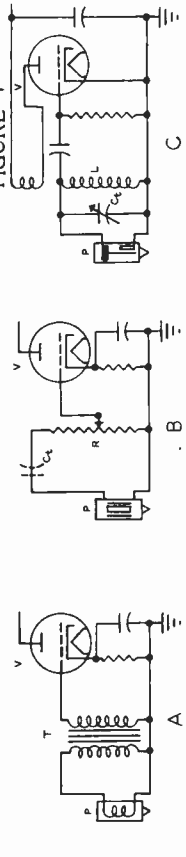

FIGURE 5

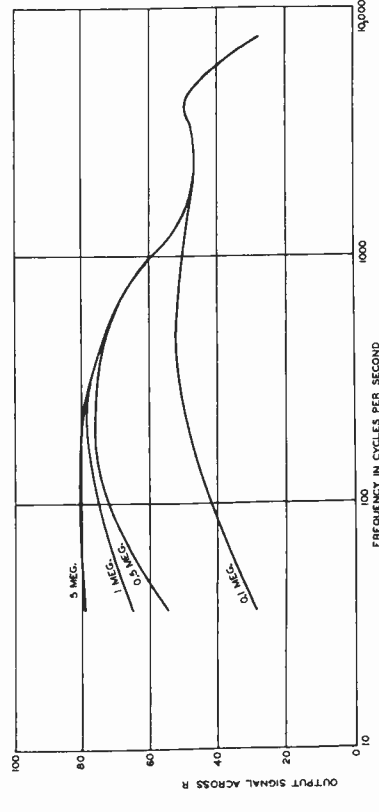

FIGURE 6

RRT-7

RRT-7

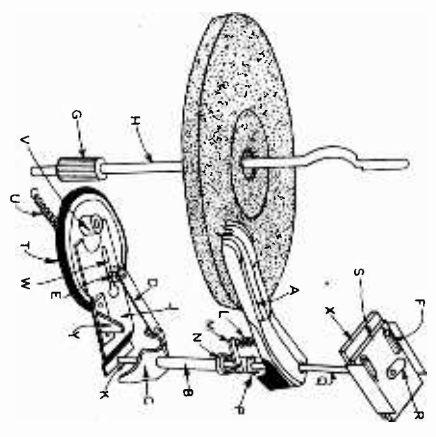

FIGURE 12

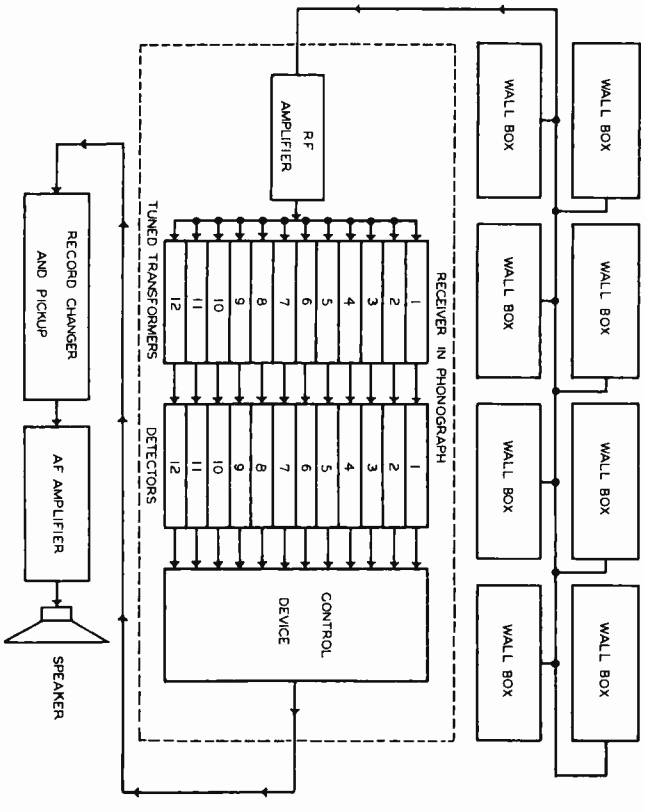

FIGURE 13







FROM OUR *President's* NOTEBOOK

THE MAN WHO WINS

The man who wins is the man who does,  
The man who makes things hum and buzz,  
The man who works and the man who acts,  
Who builds on a basis of solid facts;  
Who doesn't sit down to mope and dream,  
Who hasn't the time to fuss and fret,  
But gets there every time—you bet.

The man who wins is the man who wears  
A smile to cover his burden of cares;  
Who knows that the sun will shine again,  
That the clouds will pass, and we need the rain.  
Who buckles down to a pile of work  
And never gives up and never will shirk  
Til the task is done, and the toil is sweet,  
While the temples throb with red blood's heat.

The man who wins is the man who climbs  
The ladder of life to the cheery chimes  
Of the bells of labor, the bells of toil,  
And isn't afraid his skin will spoil  
If he faces that shine of the glaring sun  
And works in the light 'til his task is done;  
A human engine with triple beam  
And a hundred and fifty pounds of steam.

Yours for success,

*E. B. DeVey*

PRESIDENT