



**SUPERHETERODYNE  
RECEIVERS**

*Lesson* RRT-9



**DE FOREST'S TRAINING, INC.**

2533 N. Ashland Ave., Chicago 14, Illinois





Radio Reception  
and Transmission

## LESSON RRT-9

# SUPERHETERODYNE RECEIVERS

### CHRONOLOGICAL HISTORY OF RADIO AND TELEVISION DEVELOPMENTS

- 1901—First transatlantic wireless message sent by Marconi from Cornwall to St. Johns, Newfoundland.
- 1902—Reginald Fessenden invented the electrolytic detector, a device which greatly increased the effective range of wireless communication.
- 1904—Photograph sent by wire over a distance of 600 miles by Arthur Korn in Germany. In 1922 he sent a radiophoto of Pope Pius XI across the Atlantic. It was published in the New York World on June 11, 1922.
- 1904—Prof. J. A. Fleming developed the valve detector, more commonly known as the Fleming valve. It was a diode tube used as a detector of radio waves, and really was the forerunner of the modern vacuum tube.

**DE FOREST'S TRAINING, INC.**  
2533 N. ASHLAND AVE., CHICAGO 14, ILLINOIS

# RADIO RECEPTION AND TRANSMISSION

## LESSON RRT-9

### SUPERHETERODYNE RECEIVERS

#### I N D E X

Heterodyne Action .....	Page 3
Superheterodyne Circuit .....	Page 7
Local Oscillators .....	Page 10
Mixers .....	Page 13
I-f Amplifiers .....	Page 16
Second Detectors .....	Page 20
Diode Detector Circuits .....	Page 20
Audio Amplifiers .....	Page 21
Controls .....	Page 22
Selectivity .....	Page 22
Image Frequencies .....	Page 24
Sensitivity .....	Page 25
Typical Circuits .....	Page 25
Dual-Band Types .....	Page 26
All-Wave Receivers .....	Page 28

\* \* \* \* \*

Twelve Things to Remember—The value of time; The success of perseverance; The pleasure of working; The dignity of simplicity; The worth of character; The power of kindness; The influence of example; The obligation of duty; The wisdom of economy; The virtue of patience; The improvement of talent; The joy of originating.

—Marshall Field

## SUPERHETERODYNE RECEIVERS

### HETERODYNE ACTION

A simple electrical circuit contains a source of supply, either d-c or a-c, a load, connecting wires, and some means of control such as a switch. In more complicated circuits, the number of loads and controls may be increased, but usually there is only a single source of supply, as far as voltage and frequency are concerned.

While this pulsating plate current is in reality a variable direct current, it can be considered as being composed of two parts — a steady direct current on which is imposed an alternating current component. This alternating component is the result of the a-c voltage impressed on the grid, and is, therefore, often referred to as the signal current.

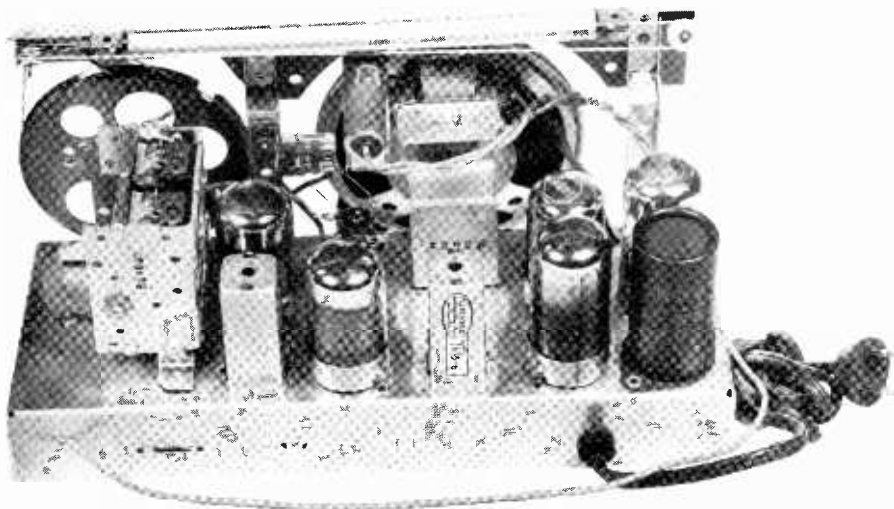

Chassis view of modern 5-tube superheterodyne receiver.

Courtesy Stewart-Warner Corporation

In our earlier explanations of electron tube operation we showed how the current in the plate circuit depends on the grid voltage; and that if an a-c voltage is impressed on the grid, a similarly pulsating plate current exists.

When the signal is to be passed on from one tube to a following amplifier tube, this pulsating plate current may be carried by the primary of a suitable coupling transformer. The steady d-c component has no effect on the

transformer secondary, but the a-c signal component sets up a pulsating magnetic flux that induces a corresponding a-c voltage in the secondary.

To investigate further the combining of several supply voltages, in Figure 1-A we have drawn a circuit which contains the series-connected secondaries of transformers T1 and T2. The primary of T1 is connected across an a-c supply with a frequency of 9 cycles, while the primary of T2 connects across a similar supply but with a frequency of 10 cycles. To simplify the explanation, we will assume that both of these sources develop voltages of equal value or amplitude.

As the secondaries are connected in series, the combined output voltage is equal to the sum of the separate voltages induced in each. Unlike d-c, a-c voltages are continually changing in value and periodically reversing polarity; therefore, the output voltage will vary as the algebraic sum of the instantaneous values of the two supply voltages. The term algebraic sum is used because at some instants the two voltages aid each other while at other instants they oppose each other.

When the voltages aid, the algebraic sum is equal to their arithmetical sum; but when they oppose, the algebraic sum is equal to the arithmetical difference.

To follow these changes in detail, curve T1 of Figure 1-B represents the voltage developed by the secondary of transformer T1, and curve T2 represents the voltage developed by the secondary of transformer T2. To check the action for one complete second, curve T1 includes 9 cycles while curve T2 includes 10 cycles. In each case, the horizontal center or base line is considered as zero, the upper lobes as "pos" and the lower lobes as "neg". The horizontal distances represent the elapsed time, as shown by the scale across the bottom, and therefore the left hand vertical line, or ordinate, is considered as the starting point of both curves.

As curve T2 starts at zero and moves to the right, it gains on curve T1, until at the end of  $\frac{1}{4}$  second, as shown by the .25 ordinate, T2 has completed  $2\frac{1}{2}$  cycles while T1 has completed but  $2\frac{1}{4}$  cycles. As a result, at this instant T1 indicates a maximum positive value while T2 indicates zero.

In curves of this type, the length of an ordinate between the base line and its intersection with the curve, is proportional to the instantaneous value of voltage. Therefore, the instantaneous values of the combined voltages can be found graphically by adding the vertical distances on the ordinates between the base line and the curves. Following this plan,

the sum of the instantaneous values of curves T1 and T2 have been plotted to form curve Ts which indicates the output voltage of the circuit of Figure 1-A.

From the starting point at the left, the instantaneous values of both T1 and T2 increase in a positive direction so that the first alternation of curve Ts has an amplitude almost twice as great as

tude of the alternations of the sum curve Ts decreases progressively, until at the .5 second ordinate all three curves have an amplitude of zero.

During this first half second, curve T2 has gained exactly one half cycle on curve T1, and therefore they both reach a zero value at the same instant, but are  $180^\circ$  out of phase. This phase differ-

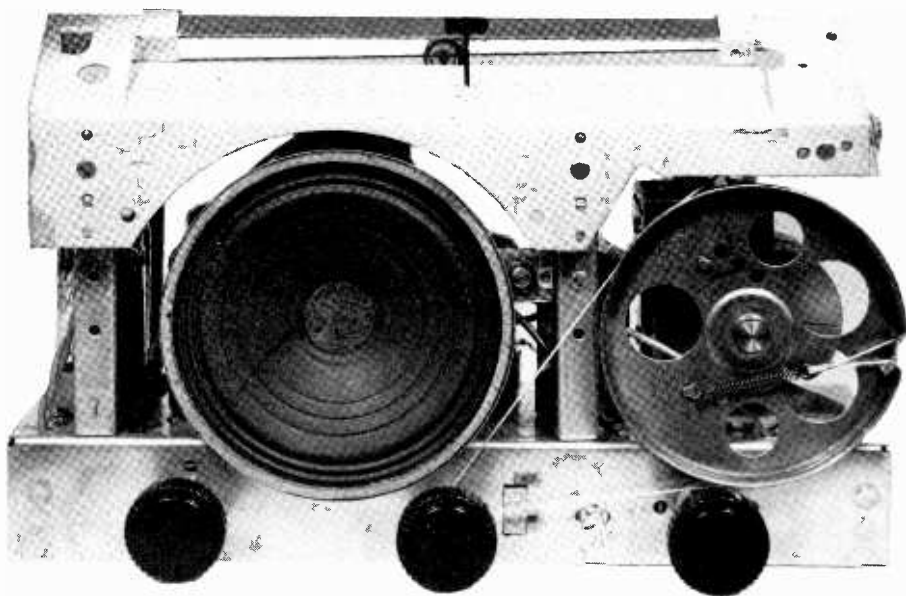

Front view of superheterodyne chassis, showing the tuning knobs, speaker, dial cord arrangement, and moving pointer.

Courtesy Stewart-Warner Corporation

either of them. However, after the third alternation some instantaneous values of T2 are negative while those of T1 are still positive. Therefore they oppose each other, and the maximum ampli-

ence reduces the output voltage, but during the next half second, curve T2 continues to gain, reducing the phase difference and increasing the amplitude of the alternations of curve Ts, until at

the end of the second, T1 and T2 are again in phase to provide maximum amplitude for curve Ts.

To be technically accurate, the voltage indicated by curve T2 has gained one complete cycle during the second, and therefore there is a phase difference of  $360^\circ$  between it and the voltage of curve T1. However, as the variations of all cycles are alike, a phase shift of  $360^\circ$ , which is one complete cycle, brings the voltages back in phase, and the variations shown by curve Ts will repeat during each succeeding second.

According to the explanations of the earlier Lessons, curve Ts resembles a modulated radio carrier, and an imaginary line drawn across its peaks shows one complete change or cycle during the second. Thus, 9 cycles of voltage T1 combined with 10 cycles of voltage T2 cause one complete change or cycle in the amplitudes of the alternations of curve Ts. Notice carefully, this one cycle is equal to the difference between the frequencies of T1 and T2.

As will be explained later in this Lesson, in some electronic circuits the value of one voltage has an effect on the other, and thus the combined voltage can be considered as the product rather than the sum of the separate voltages. Following the plan of plotting curve Ts, but using the prod-

uct of the instantaneous values of curves T1 and T2, a curve like that of Tp results. To keep the curves of uniform size, the vertical scale of Tp has been reduced, but notice that the broken line drawn through the vertical center of the variations has the same general shape and frequency as the imaginary line drawn across the peaks of curve Ts. Also, the 19 shorter cycles of curve Tp are equal to the sum of the 9 and 10 cycle frequencies of the curves of T1 and T2.

Curve Tp is merely a graphical representation of the fact, proven experimentally and mathematically, that when voltages of different frequencies are combined, the output contains frequency components equal to both the sum and difference of the original frequencies which are also present. .

This is known as a "Heterodyne" action and occurs whenever two a-c voltages or currents of different frequencies are impressed on one circuit. The periodic change in the amplitude of the combined voltages is known commonly as a "Beat" frequency, and its value is equal to the sum or difference of the applied frequencies. However, as explained in the earlier Lesson on Detector Circuits, some form of demodulation must be employed to make the beat frequency available.



For simplicity, the voltages represented by curves T1 and T2 are shown as sine waves, but irregularities in either wave form will also appear in the combined voltage. This can be readily understood by remembering that the instantaneous values of curves like Ts and Tp are determined from the instantaneous values of the original voltages. Changes in the wave form of an original voltage change its instantaneous values, and thus will have a proportional effect on the wave form of the combined voltage.

## SUPERHETERODYNE CIRCUIT

This mixing or heterodyne action is utilized in the operation of most modern radio receivers in what is known as a Superheterodyne circuit, shown in simplified block form in Figure 2. The complete circuit can be divided into six main sections, each of which causes some definitive change in the amplitude or frequency of the modulated carrier, or in the amplitude of the signal voltage.

At the left of Figure 2, the modulated carrier of a Broadcast

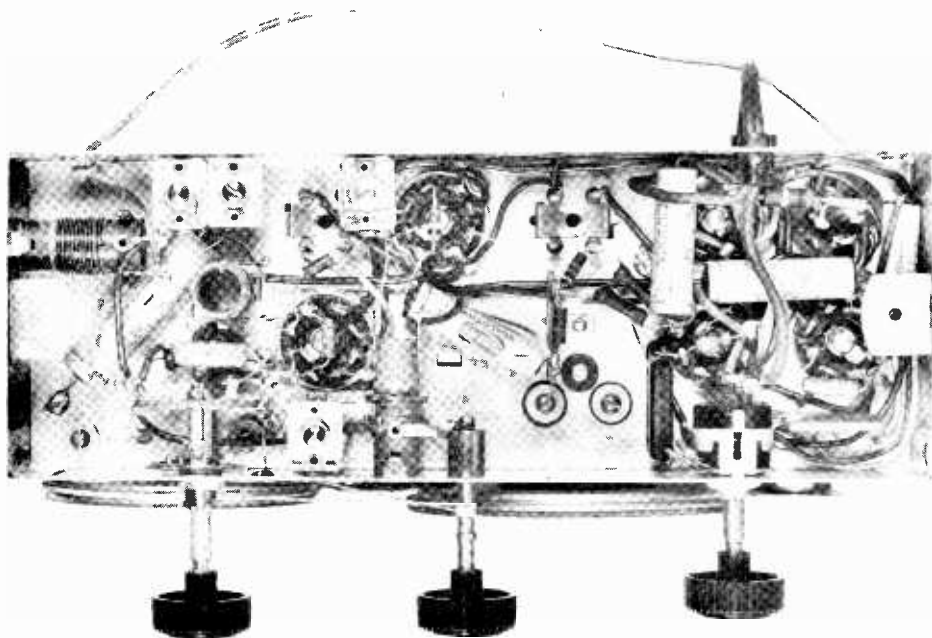

Bottom view of chassis shown in the two previous illustrations.

Courtesy Stewart-Warner Corporation

Station is picked up by the usual form of antenna circuit and its amplitude is increased by one or more stages of r-f amplification.

generates a frequency of uniform amplitude which heterodynes with the output of the r-f amplifier to produce a beat signal of lower

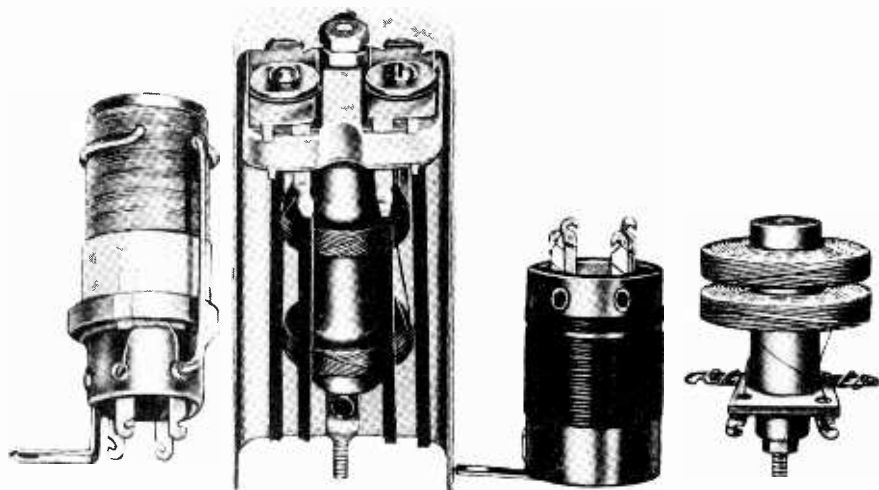

Superheterodyne coil kit. First coil at left is the antenna coil, second from the left is the input i-f transformer, third is the oscillator coil, and fourth is the output i-f transformer.

J. W. Miller Company, Los Angeles

The action here is the same as explained for the trf type of receiver, and the amplifier includes circuits which are tuned to the frequency of the incoming carrier. Thus, the function of the r-f amplifier is to increase the amplitude without causing any change in the frequency of the carrier.

The output of the r-f amplifier is fed into the Mixer which also connects across the output of the Local Oscillator. This oscillator

frequency. This beat frequency also carries the modulation of the carrier.

It is known as the Intermediate Frequency (i-f), and its value is equal to the difference between the carrier and oscillator frequencies. In effect, the mixer acts somewhat as a detector with the higher values of oscillator and carrier frequencies impressed on its input circuits while the lower intermediate frequency appears in its output circuit.

The mixer output carries the modulation of the original carrier and then passes through one or more stages of the i-f amplifier. This causes a comparatively large increase in amplitude, but like the r-f amplifier, causes no change in frequency.

The output of the i-f amplifier is impressed on the input circuit of a conventional type of detector, which demodulates the i-f and provides the audio or signal voltage frequencies in its output. The detector output voltage is then carried through one or more stages of an a-f amplifier which increases its amplitude to a level high enough to operate the speaker.

As the mixer acts to cause a change of frequency between its input and output circuits, it is sometimes known as the "1st Detector", and therefore, the demodulator which follows the i-f amplifier is the "2nd Detector". It is said that with its heterodyne action and two detectors, it followed naturally that the circuit was called a "Super" heterodyne. Due to the design of some of the later types of tubes, the mixer stage is known also as a "Frequency Converter".

The advantages of this type of circuit can be appreciated best by comparing it with the older type of trf receiver explained in

the earlier Lessons. By removing the Mixer, Local Oscillator and i-f Amplifier sections of Figure 2, the arrangement is that of a trf receiver, and all of the high-frequency amplification must be accomplished in the r-f amplifier.

This means that all of the tuned circuits must be designed to resonate at all frequencies of the desired band, and as previously explained, it is extremely difficult to design a simple circuit which will provide uniform response and adequate gain over a comparatively wide band of frequencies. For example, the Broadcast band extends from about 550kc to 1600 kc, a ratio of over 3 to 1, and a change of circuit values to provide resonance over this range usually causes undesirable changes in response.

In the superheterodyne circuit, the tuning controls of the r-f amplifier, mixer and oscillator can be ganged mechanically, so that regardless of their position, the difference between the resonant frequencies of the tuned circuits and oscillator output will always remain the same.

For example, suppose the arrangement of Figure 2 is designed to cover the broadcast band and that the i-f amplifier is tuned permanently to a frequency of 456 kc. With the tuned circuits adjusted to resonate at 550 kc, the ganged

control will cause the oscillator output to have a frequency of 550 plus 456 or 1006 kc.

Then, as the tuning control is adjusted to increase the resonant frequency of the input circuits, it causes a proportional increase in the frequency of the oscillator, so that the beat or intermediate frequency remains the same. This condition holds for the entire band, and when the receiver is tuned to 1600 kc, the oscillator frequency is 1600 plus 456 or 2056 kc.

Perhaps the most important feature of the superheterodyne is that, with a mixer output of but one fixed frequency, the tuned circuits of the i-f amplifier can be designed to operate at this one frequency only. Operation at a fixed frequency has two advantages, (1) selection of circuit components of values which provide high gain (2) use of band-pass circuits with fixed tuning to improve the selectivity. Therefore, most of the gain is provided by the i-f amplifier, and its efficiency is so great that but one stage is sufficient in many cases and the r-f amplifier is omitted.

In a trf receiver it is customary to tune one or several circuits in each amplifier stage between the antenna and detector. These circuits, therefore, must tune over the entire band, and each must be reset when a different carrier

is to be selected. While the same general requirements are true for the superheterodyne, only the oscillator circuit and those between the mixer and antenna have to be set for the individual carriers, while the i-f amplifier circuits need not be changed. Thus, although the superheterodyne circuit may contain a greater number of tuned circuits than a comparable trf receiver, the tuning components in actual operation usually are less in number.

While it is possible to build a trf receiver with performance characteristics equal to those of a superheterodyne, the greater efficiency of the single-frequency intermediate amplifier reduces the number of stages required. Also, the fixed tuning of the i-f amplifier circuits reduces the number of tuning controls, and these advantages together with those mentioned above, more than compensate for the addition of the local oscillator and mixer stages.

## LOCAL OSCILLATORS

Before taking up the details of a complete circuit, we will explain the operation of the various sections of Figure 2. The signal picked up at the antenna enters the r-f amplifier but since the circuits are similar to those explained previously for a trf receiver, we will not take time to repeat here.

The function of the Local Oscillator section is to generate a signal of uniform frequency which is combined with the incoming r-f signal to produce the intermediate frequency. There are a number of comparatively simple oscillator circuits which meet these requirements, and for Figure 3 we show the circuits of an arrangement used in many older models of superheterodyne receivers.

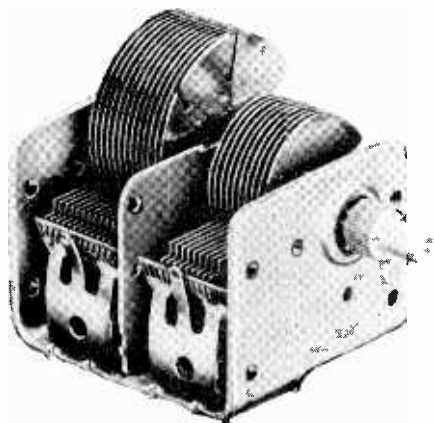

Typical two-gang condenser used for tuning the input stage and oscillator of a superheterodyne receiver. Since the oscillator operates at a higher frequency, less condenser tuning capacitance is required. Also, the oscillator rotor is specially shaped, so that the proper tuning calibration will be maintained.

Kings Electronics Company

The oscillator itself is of the regenerative or Armstrong type with L5 as the plate coil connected between the plate of the tube and the B+ of the plate supply. Inductively coupled to the plate coil, the grid coil L4 is tuned by the parallel connected variable

condenser C2 and coupled to the grid of the tube through condenser C4. Resistor R2 functions as the grid load, and the voltage drop across it, caused by the charge and discharge currents of C4, provides the grid bias voltage for the oscillator tube.

Coil L3, being inductively coupled to coils L4 and L5, is connected in the cathode circuit of the 1st detector tube in series with resistor R1, which with bypass condenser C3, provides the usual grid bias voltage for the 1st detector. The complete grid circuit of the 1st detector tube can be traced from the grid through coil L2 (tuned to the frequency of the incoming carrier by variable condenser C1) to ground, and back up through resistor R1 and coil L3 to the cathode.

With a modulated carrier impressed across coil L1, a voltage of like frequency and proportional amplitude will be induced in coil L2 and impressed on the grid circuit. When L2 is tuned to resonance by C1, the voltage across L2 will be increased to provide selectivity as previously explained. The plate current carried by R1 will cause the proper voltage drop to bias the grid and hence provide the proper operating point for the 1st detector tube.

At the same time, with the oscillator in operation, a voltage at the oscillator frequency will be in-

duced in coil L3, which, as far as the grid circuit is concerned, is connected in series with coil L2. Thus, the arrangement in the grid circuit of the 1st detector tube provides conditions similar to those in the simple circuit of Figure 1-A, and therefore voltages at the incoming carrier and oscillator frequencies are both impressed on the grid.

As a result, the action shown by the curves of Figure 1-B will occur in the grid circuit and cause corresponding variations of plate current. However, the bias voltage caused by the drop across R1, is sufficient to provide operation as a detector, and therefore the beat frequency, which carries the modulation of the carrier, will appear in the plate circuit over the entire tuning range of the receiver.

Coil L6, which is tuned to the beat frequency by trimmer condenser C5, is connected in series in the plate circuit; and as in the case of any parallel resonant circuit, the beat-frequency plate current develops maximum voltage drop across this tuned transformer primary. At above-resonant frequencies the condenser reactance diminishes rapidly, and hence the current cannot build up any appreciable voltage drop. Similarly, at below-resonant frequencies the coil reactance drops off, and again the voltage drop

is reduced. Therefore, it is the fact that the impedance of a parallel circuit is maximum at resonance and the current will cause maximum voltage drop, which permits a tuned i-f transformer to provide maximum amplification only at the desired frequency.

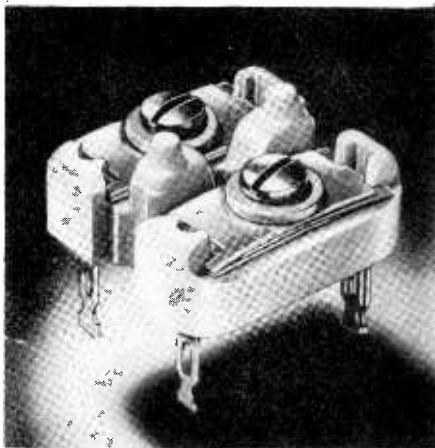

Typical small mica-type variable condensers used as trimmers and padders in superheterodyne receivers.

Automatic Manufacturing Company

With maximum voltage drop across coil L6, there is maximum induction in the inductively-coupled coil L7, which is tuned by trimmer condenser C6, and thus the beat-frequency voltage appears across coil L7. The combination of coils L6 and L7, each with its adjustable trimmer condenser, is known as an i-f transformer.

Tuning condensers C1 and C2 are ganged mechanically so that when the capacity of C1 is re-

duced to increase the resonant frequency of its tuned circuit, the capacitance of C2 is reduced also to cause a proportional increase in the frequency of the oscillator voltage. To maintain a constant frequency difference, the circuits of the oscillator and 1st detector grid must be carefully designed to provide the required tuning components. If C1 and C2 are of equal capacitance, coil L4 must have a lower value of inductance than coil L2, since the circuit tunes to a higher frequency.

To maintain the proper frequency difference as condensers C1 and C2 are tuned, it is necessary to install the series-connected condenser C7. This is known as a "Padder"; and while its series arrangement reduces the total capacitance always connected across the oscillator coil, the real function of a padder condenser is to maintain the proper difference in frequencies between the oscillator and r-f circuits so that a constant intermediate frequency is developed over the entire tuning range of the receiver.

To eliminate the padder condenser, many later receiver models have the oscillator gang of the tuning condenser made of smaller, specially shaped plates to provide the proper change of capacitance as the rotor plates of all the tuning condenser gangs are turned in unison.

Various combinations of tubes and circuits have been devised to simplify and improve the actions of the circuits of Figure 3, and one combination formerly quite popular, is shown in Figure 4. Here, the circuits are quite similar, but the oscillator tube has been eliminated and an r-f type of pentode tube acts as both oscillator and 1st detector.

Coil L5 is in the plate circuit and coil L3 in the cathode-grid circuit to provide the necessary feedback, while coil L4 which is inductively coupled to both, is tuned by condenser C2 in series with padder C7, to provide the desired frequency. The circuit action here is about the same as that explained for Figure 3, and the beat frequency appears across the secondary coil L7 of the i-f transformer. To make the comparison easier, corresponding components of both Figures 3 and 4 carry the same numbers.

## MIXERS

To provide better performance and also simplify the circuits, several types of special "Mixer" or "Frequency Converter" tubes have been developed; and while their overall functions are similar, there are some important variations in the details of their operation.

One such type shown in Figure 5, is known as a Pentagrid Con-

verter because its five grids combine the functions of both oscillator and mixer. Starting from the cathode, the first grid functions as the control grid of a triode oscillator tube, while the second grid functions as the oscillator plate. However, although indicated by the same symbol as the other grids, mechanically it consists of two side rods without horizontal wires, and this second grid is known as the oscillator anode.

This anode connects to the B+ of the plate supply through coil L5 and resistor R3, while the 1st grid is coupled through condenser C4 to the tuned circuit made up of coil L4 and tuning condenser C2. Resistor R2 acts as the grid load, while resistor R3 reduces the potential on the anode, and in conjunction with condenser C7, acts as a decoupling filter.

The oscillator circuits here are similar to those of Figure 3, except that coil L3 is omitted. However, feedback from the anode to the grid is provided by the inductive coupling between coils L4 and L5, and thus the arrangement operates as a triode oscillator.

The electrons emitted by the cathode are attracted toward the positive anode, but the action of the grid varies the stream at the oscillator frequency. Grids 3 and 5 as well as the plate of the tube

are also connected to the plate supply positive, and therefore many of the electrons pass through the anode and continue on to the plate. It may help to think of the anode as the emitting cathode, as far as the plate circuit of the tube is concerned, but its emission varies at the frequency of the oscillator.

Grids 3 and 5 connected together inside the tube, serve a double purpose. First, being maintained at a positive potential by the plate supply, they speed up the electrons which pass through the anode; and second, they form an electrostatic shield for grid 4. Resistor R4 and condenser C8 act to maintain a uniform but reduced positive potential on screen grids 3 and 5.

Grid 4, connected to the input circuit, operates in the conventional manner to control the electrons which flow from the anode to the plate. As the electron stream is already varying at the oscillator frequency, the variations of plate current are controlled by the combined actions of the oscillator and the modulated carrier impressed on grid 4. Types 1A7G, 1C6, 2A7, 6A8 and 12A8 are common examples of this type of pentagrid converter tube.

To provide better performance at higher frequencies and reduce



the effects of interaction between the oscillator and other section of the tube, some later types of pentagrid converters are arranged on the plan shown in Figure 6. Here, grid 1 functions as the oscillator control, grids 2

and 4 as the oscillator anode and also as a shield for the signal input grid 3, while grid 5 acts as a suppressor.

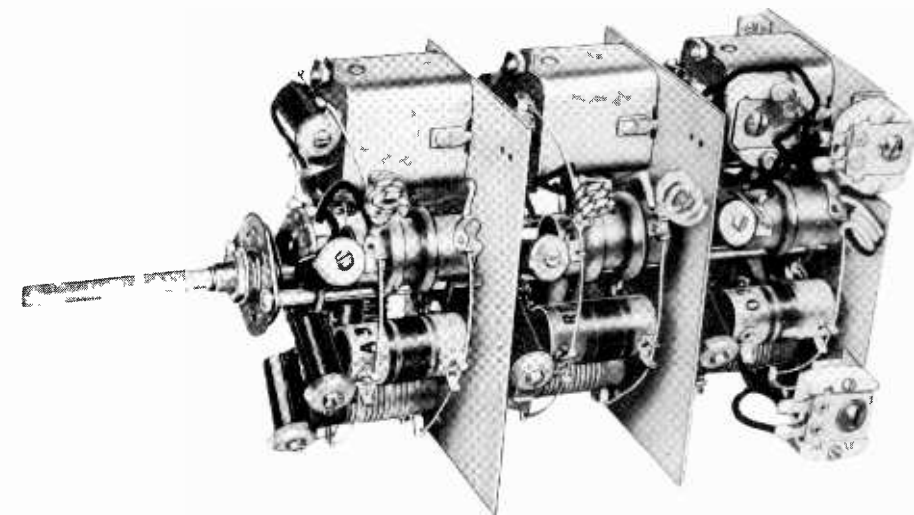

Coil and trimmer assembly for an all-wave radio receiver.

Meissner Manufacturing Division

and 4 as the oscillator anode and also as a shield for the signal input grid 3, while grid 5 acts as a suppressor.

The oscillator circuit of Figure 6 consists of coil L3, tuned by variable condenser C2 and coupled through condenser C4 to grid 1. Grid load resistor R2 connects from grid 1 to the cathode, which in turn connects to ground through a tap on coil L3. Thus, that part of L3 between the tap and ground is in the cathode cir-

cuit, while the entire coil is coupled to the grid. As the cathode is part of the anode circuit, this can be considered as a Hartley oscillator, and since the action is independent of the plate of the tube, it is electron coupled.

Here again, the variations of plate current are controlled by the combined effects of the oscillator voltage on grid 1 and the modulated carrier voltage on grid 3. Types 6SA7 and 12SA7 are common examples of this type of pentagrid converter.

To further isolate the oscillator, the "Triode-Hexode" type of converter tube has been developed, and now is also in common use. As shown in Figure 7, the electrodes are arranged so that the

tube contains a separate triode section in addition to a hexode section. The term hexode is used

internally to grid 1 of the hexode section.

The circuits here are similar to those of Figure 5 except that the oscillator plate coil L5 is tuned by condenser C2 and coupled to the oscillator plate through condenser C7 instead of being connected in series. However, the overall action remains the same, and the triode section operates independently as an oscillator.

Because grid 1 of the hexode section is connected to the oscillator grid, the oscillator voltage will exercise control over the hexode plate current as explained for the circuits of Figures 5 and 6. Types 6K8 and 12K8 are examples of triode-hexode converter tubes.

You will find many combinations of these basic circuits used in commercial radio receivers, especially those designed for communications and high-frequency service. For example, the type 6L7 tube contains two well shielded control grids; and with a separate oscillator on the general plan of Figure 3, the oscillator voltage can be impressed on one control grid and the modulated carrier on the other to provide the desired mixing or frequency conversion action.

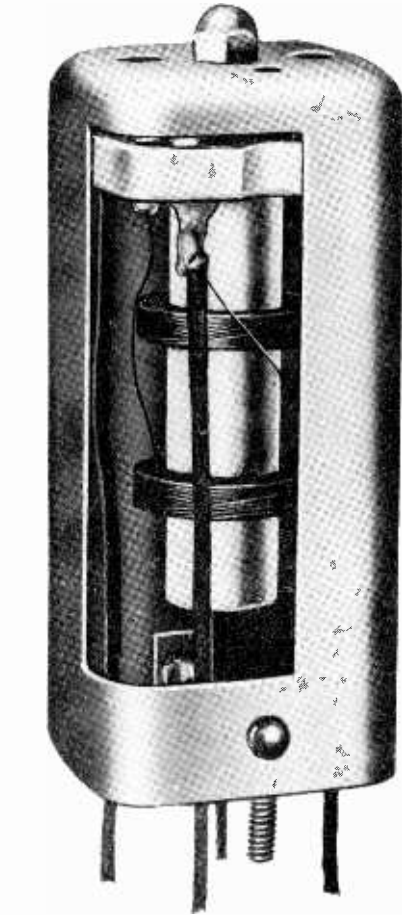

I-F transformer designed primarily for replacement purposes. Equipped with mica compression trimmers, and housed in aluminum shield. Available in the commonly used frequencies.

J. W. Miller Company

to signify the six active electrodes of plate, four grids and cathode, while the triode grid is connected

## I-F AMPLIFIERS

As mentioned earlier in this lesson, the i-f amplifiers in super-

heterodyne receivers are designed to operate at a constant frequency, and consequently maximum efficiency can be incorporated in them. The two main advantages gained from such fixed-frequency amplifiers are greater selectivity and higher gain. Transformer coupling is used almost exclusively in i-f amplifiers, since this readily makes available the important features of band-pass circuits.

All i-f transformers contain a primary and secondary winding, and because of the single-frequency operation, either or both of them can be tuned. In some cases the windings are untuned, while in others one winding is tuned to provide the circuits of Figure 8-A. Most popular is the double-tuned arrangement of Figure 8-B, while for broad band or high fidelity, the triple-tuned circuits of Figure 8-C may be employed.

In the earlier Lesson on High-Frequency Amplifiers it was shown that for broadcast service the response curve of an i-f amplifier should have a fairly flat top, approximately 10 kc wide, with steep sides to provide a sharp cut off. Also, in the Lesson on Band-Pass Filters it was shown that loose coupling causes a narrow response while overcoupling causes a double hump which broadens the response.

The double-tuned arrangement of Figure 8-B can be considered as a band-pass type of coupling, both circuits of which are tuned to resonance at the operating frequency. Mechanically the coils are universally wound and mounted on a common dowel, the coupling depending on the spacing between them. Thus, by adjusting the position of the coils on the dowel, the desired or optimum coupling can be obtained.

In the arrangement of Figure 8-C, the third coil, sometimes called a tertiary winding, will absorb a certain amount of energy when its circuit is tuned to resonance. This "loads" the circuit and broadens the frequency response curve of the unit. In some receivers which feature variable selectivity, a variable resistance is connected between the tertiary winding and ground. Variable selectivity may be obtained also by changing the coupling between the two coils in a circuit like that of Figure 8-B. This may be accomplished by mechanically moving the coils to vary the distance between them or by switching in a third coil connected in series with one of the tuned circuits.

As shown in Figure 8, the coils are of fixed value and tuning is accomplished by means of trimmer type adjustable condensers connected across the coils. Other types of i-f transformers are

made with fixed values of capacitance, and tuning is accomplished by changing the position of a powdered iron "slug" which functions as the core of the coil. Changing the position of the slug

A single stage i-f amplifier with circuits similar to those of Figure 9, provides sufficient gain and selectivity for the ordinary types of broadcast receivers. The primary of the "1st i-f" transformer



Modern all-wave signal generator designed for tuning and aligning the r-f, oscillator, and i-f stages in superheterodyne receivers.

Courtesy Simpson Electric Company

varies the permeability of the complete core, part of which is air, and this, in turn, varies the inductance. Transformers of this type are generally listed as "Iron-Core Permeability-Tuned".

is connected in series with the plate of the mixer tube, as shown in the circuits of Figures 3 to 7, while the secondary of the "2nd i-f" forms a part of the input circuit of the 2nd detector. How-

ever, some designers prefer to reduce the gain in each tube and add a second stage so that the i-f amplifier includes two tubes and three transformers.

The impedance of a parallel resonance circuit can be expressed by the formula :

$$Z = \frac{L}{CR}$$

Then by changing the ratio of the inductance to capacitance, the impedance of the parallel circuit can be varied.

Thus, the tuned primary acts as the plate load of the preceding tube while the tuned secondary acts as the grid load of the following tube; and with the coupling between the coils adjustable, the gain and response of the stage can be made to suit the required conditions. That is why in most catalogs you will find i-f transformers listed as "Input", "Interstage" and "Output", although all three types are designed to operate at the same frequency. The differences are in the values of inductance and capacitance, as well as the coupling, to provide the proper gain and frequency response for the complete amplifier.

For example, when connected in the plate circuit of the mixer tube, the primary of the 1st i-f must carry some of the higher frequencies of the oscillator and modulated input carrier. Thus, a somewhat higher value of capac-

itance here will provide a lower reactance path in parallel with the coil, and tend to reduce interaction with the lower intermediate frequency to which the circuit is tuned.

The secondary of the 1st i-f connects across the grid circuit of the following tube, which operates as an amplifier with a negative bias and offers an extremely high impedance. Therefore, in effect, the circuit operates with no load. In contrast, the secondary of the 2nd i-f of Figure 9 connects across the 2nd detector, which, usually being of the diode type, has a comparatively low impedance and carries current. Therefore, this secondary circuit operates under load and must be designed accordingly.

For the interstage transformer used as a coupling device between the input and output tubes of a two-stage i-f amplifier, conditions in its primary circuit are like those of the 2nd i-f of Figure 9 with current variations only at the intermediate frequency. Its secondary operates under conditions like those explained for the secondary of the 1st i-f of Figure 9, and therefore it is not loaded.

Each of the three types of i-f transformers is designed to meet the circuit conditions as mentioned above, and in addition, the coupling is adjusted for each so that in conjunction with the other

transformers of the amplifier, the desired overall gain and selectivity will be obtained. For example, if the input type is adjusted for a gain of 50, the interstage may have a gain of about 20, while the output gain may be about 70. If, at some certain level, the band width of the input is 15 kc, that of the interstage may be about 10kc, while that of the output may be 16 kc or 17 kc.

## SECOND DETECTORS

Except for a difference in carrier frequency, the output of the i-f amplifier is the same as the modulated carrier transmitted by a broadcast station, and therefore, the function of the 2nd detector is the same as previously explained for the detectors of the trf types of receivers. Any of the conventional types of detectors will operate in this position in a superheterodyne circuit, but due to the relatively high gain of the i-f amplifier, no additional gain is required in the detector stage. Thus, because of their ability to handle larger voltages with less distortion, practically all superheterodyne circuits employ some form of diode as the second detector.

## DIODE DETECTOR CIRCUITS

To review briefly the explanations of the former Lesson on Detector Circuits, for Figure 10

we show the circuits of a typical diode detector. Coil L2, tuned by condenser C2, represents the secondary of the output transformer of the i-f amplifier, and thus the modulated i-f voltage is impressed on the circuit. This can be traced from the upper

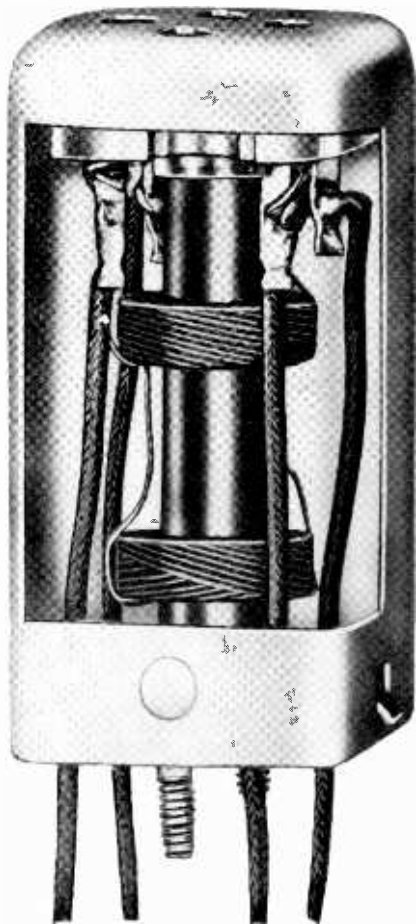

Universal i-f transformer, combining high gain and stability with a compact physical size. Used in modern home, auto, and portable superheterodyne receivers.

Courtesy J. W. Miller Company

end of L2 through the diode plate and cathode of the tube to ground, and back up through resistors R2 and R1 to the lower end of L2.

The rectifying action of the diode permits current in one direction only, therefore the current in the circuit will consist of a series of pulses which occur at the intermediate frequency and vary in amplitude according to the modulation or signal frequency. To eliminate the pulses and provide current which varies only in proportion to the signal frequency, condensers C3 and C4 connect from the ends of resistor R1 to ground and form a filter.

The capacitance of these condensers must be large enough to eliminate the intermediate frequency pulsations, yet small enough to have no appreciable effect on the variations of the audio or signal voltages. Thus the signal voltages appear across resistor R2 and are coupled to the grid of the first audio tube through condenser C5.

As the voltage across filter resistor R1 is lost as far as the following audio circuits are concerned, it is common practice to select a value for R1 that is about 10% of that for R2. For typical values, R2 is 500,000 ohms, R1 is 50,000 ohms, C3 and C4 are .0001 mfd each and coupling condenser C5 is .01 mfd. The value

of R3 will depend on the type of tube installed as the 1st audio amplifier, and may vary from .5 to 10 megohms.

There are many variations of this typical diode detector circuit, but all of them include the basic components just mentioned. Also, as will be explained in a later Lesson, circuits of this type provide a source of voltage for the popular feature of automatic volume control.

## AUDIO AMPLIFIERS

The output of the second detector of a superheterodyne circuit is essentially the same as the output of the detector of the other types of receivers, and therefore, the conventional types of audio amplifiers are employed. However, the amplitude of the detector output is usually of sufficient strength to require but two stages of audio amplification to provide ample signal voltage for satisfactory speaker operation.

Depending on the power requirements, the audio amplifier may terminate in a single or push-pull stage employing any of the circuits explained in the earlier Lesson on Audio Amplifiers.

To repeat, the superheterodyne differs from other types of receivers only in the arrangement of the mixer, oscillator and i-f

amplifier, and therefore the requirements of the audio amplifier are the same for all.

## CONTROLS

Despite its more complicated action, a modern superheterodyne requires no more controls than the simpler types of circuits. As previously explained in this Lesson, a single tuning control is arranged to vary the resonant frequencies of the r-f amplifier if one is used, and of the mixer input and oscillator circuits, so that they will respond to the carrier frequencies of the band and yet maintain a constant i-f at the mixer output. As far as the operator is concerned, this tuning control is no different than that of a simple one-tube receiver.

The volume control is usually incorporated as a part of the 2nd detector circuit on the general plan of Figure 10. Here the signal voltage appears across R2 which is a potentiometer. The sliding contact is coupled through C5 to the grid of the first audio amplifier tube, and therefore, only that voltage between the sliding contact and ground is impressed on the grid circuit. Thus, for any value of 2nd detector output voltage, the input voltage to the audio amplifier is controlled by the position of the sliding contact, which therefore acts as a volume control.

In addition to the "Off-On" power switch, the tuning and volume controls are all that are necessary for the operation of the receiver. However, tone control can also be added to the audio amplifier circuits, adjustable selectivity can be incorporated in the i-f amplifier circuits, and, as will be explained later in this Lesson, circuits can be installed to provide for reception on different frequency bands.

## SELECTIVITY

Perhaps the most important advantage of the superheterodyne receiver circuit is its inherent selectivity. Since it operates at a single frequency with band-pass coupling circuits, the response of the i-f amplifier can be designed for almost any value of band width. In some of the earlier models, the pass band was so narrow that the higher signal frequencies were attenuated.

To understand this action, it must be remembered that the modulation of a radio-frequency carrier involves an action very similar to the heterodyne effect explained earlier in this Lesson. For example, suppose a 1000-kc carrier is modulated by audio or musical frequencies up to 5000 cycles, which is 5 kc. The modulated carrier will then include frequencies from 1000 kc up to 1000 plus 5 kc or 1005 kc, and



down to 1000 minus 5 kc or 995 kc.

With the receiver tuned to this carrier, the oscillator of a 456-kc i-f superheterodyne will operate at 1456 kc, and therefore, the frequencies at the mixer output will vary from 1456 minus 995 or 461 kc to 1456 minus 1005 or 451 kc. Notice here that although the frequencies have been reduced, the band width of the i-f is the same as that of the modulated carrier.

Assuming the i-f amplifier has a response curve with a flat top but 8 kc wide, when tuned to 456 kc the maximum response will extend from 456 plus 4 or 460 kc to 456 minus 4 or 452 kc. Compared to the values given above, intermediate frequencies between 451 and 452 kc as well as those between 460 and 461 kc will receive less amplification than those between 452 and 460 kc.

With an oscillator frequency of 1456 kc, an i-f of 451 kc is produced by a carrier frequency of 1456 minus 451 or 1005 kc. In the same way, an i-f of 452 kc is produced by a carrier of 1456 minus 452 or 1004 kc. At the other end of the band an i-f of 460 represents a carrier of 996 kc, while an i-f of 461 kc represents a carrier of 995 kc. As the original carrier was assumed to have a frequency of 1000 kc, frequencies between 1004 and 1005

kc as well as those between 995 and 996 kc are produced by modulating or signal voltages between 4000 and 5000 cycles.

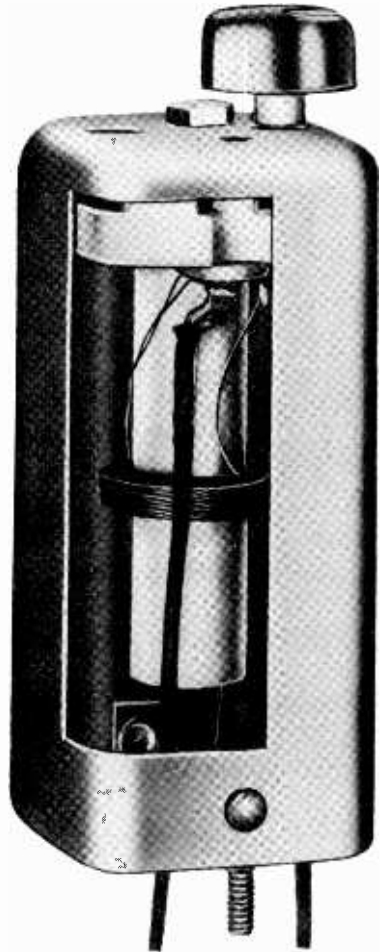

Beat Frequency Oscillator coil. Frequency adjustments can be made by means of a small knob accessible at the top of the shield.

J. W. Miller Company

The frequencies of the 2nd detector output voltage are essen-

tially the same as those of the original modulation, and thus under the conditions of this example, all signal voltages between 4000 and 5000 cycles would be attenuated. Signal voltages with frequencies up to 4000 cycles would be fully amplified; therefore, when an i-f amplifier is tuned too sharply it "cuts the highs".

In commercial practice it is customary to make a compromise by adjusting the response for a band wide enough to include all the signal frequencies but narrow enough to eliminate most of the interference from adjacent carrier frequencies.

### IMAGE FREQUENCIES

In the example just given, the 1000-kc carrier and 1456-kc oscillator were mixed or heterodyned to produce a beat of 456 kc; but suppose another carrier at 1912 kc were also cutting the antenna and inducing a voltage in it. The heterodyne action between the 1456-kc oscillator and 1912-kc carrier would also produce a 456-kc beat, and if both these carriers caused equal voltage in the mixer input circuit, both would be amplified equally by the i-f stages and produce equal signals in the speaker.

Notice carefully, the difference between 1912 kc and 1000 kc is 912 kc which is exactly twice the

456 kc of the i-f. This relationship holds true in all cases, and the higher value is known as the "Image Frequency". Thus, in general, the image frequency is equal to that of the desired carrier plus twice the i-f.

Image frequencies were considered an important disadvantage of the early models of superheterodynes, but by ganging the tuning controls of the mixer and oscillator, providing some selectivity ahead of the mixer, and increasing the i-f, image frequencies are no longer troublesome in the broadcast band.

Starting with values of less than 100 kc, intermediate frequencies were increased until a value of 175 kc was considered standard. Over the years, further increases were made passing through bands of 260 to 265 kc, 370 kc, and up to the present values of 455 to 470 kc for regular broadcast service. Receivers designed for higher frequency service usually incorporate i-f amplifiers which operate at much higher frequencies.

With an i-f of 456 kc, there is a difference of 912 kc between the tuned carrier and the image frequency, and as the broadcast band covers less than 1200 kc, interference of this type is reduced. Also, for any circuit tuned to the broadcast frequencies, it does not require a high degree of

selectivity to greatly attenuate frequencies 912 kc off resonance. For higher carrier frequencies, the ratio of resonant to image frequencies is less favorable, and added precautions must be taken to avoid image frequency interference.

## SENSITIVITY

In an earlier definition it was stated that all stages of a radio receiver contribute to its Sensitivity, but due to the high gain characteristics of the i-f amplifier, the superheterodyne circuit will provide satisfactory sensitivity with fewer stages than other types.

The advantages of the superheterodyne are so pronounced that some small four tube receivers incorporate but one i-f transformer, and provide performance superior to trf receivers with an equal number of tubes.

## TYPICAL CIRCUITS

Although there are many variations in details, modern superheterodyne circuits now follow a fairly uniform pattern and can be divided into general classes. From the standpoint of Power Supply, there are the following types:

1. Battery Receivers, used for portable service and containing

dry batteries which supply all the operating voltages and currents.

2. Receivers which operate on any ordinary 110-volt lighting circuit, d-c or a-c of any commercial frequency.

3. Receivers which operate only on a-c lighting circuits of one frequency such as the common values of 25 or 60 cycles.

4. A combination of types 1 and 2 which provide portable service but conserve the batteries by operating on lighting circuits whenever they are available.

From the standpoint of operating frequencies there are:

1. Types which operate on the standard broadcast band only.

2. Dual-Band types which operate on the standard broadcast band and another higher frequency or short-wave band.

3. All Wave types which operate on the standard broadcast and two or more bands of other frequencies. Some later models include the newer frequency-modulation bands.

The complete receiver chassis may be installed in a comparatively small "Table Model" cabinet or in a larger "Console", both of which are available in a wide variety of shapes, sizes, colors and finishes.

## DUAL-BAND TYPES

To illustrate the complete assembly of the various receiver components explained earlier in this Lesson, for Figure 11 we show the schematic diagram and chassis layout of a Sentinel 6-tube dual-band a-c d-c superheterodyne receiver. Starting at the upper left of the diagram and following the path of the signal, there is a 12SK7 tube used as an r-f amplifier, resistance coupled to the 12SA7 tube marked "OSC-MOD". This tube functions as the mixer, and the oscillator coils are shown directly below in the lower part of the diagram.

The 12SA7 mixer tube is coupled through the 1st i-f transformer to the 12SK7 i-f amplifier tube, and its output is coupled through the 2nd i-f transformer to the diodes of the 12SQ7 tube. The diodes are a part of the detector circuit which is coupled to the grid of the triode section of the 12SQ7 through the .005-mfd condenser shown below the tube and to the right of the volume control. This triode section acts as the 1st a-f amplifier and is resistance-coupled to the 50L6-GT beam power output tube, which, in turn, is coupled through the output transformer to the speaker.

As shown at the lower right, the heaters of all the tubes are connected in series across the 117-

volt supply, while the plate of the 35Z5 half wave rectifier tube connects to one side of the supply line through the parallel connected 100-ohm resistor, 6-8 volt pilot lamp, and part of the 35Z5 heater. As the other line wire is grounded, the d-c voltage output of the rectifier tube is available between its cathode and ground.

From this cathode there is one circuit over to the right, up, over and down through the speaker field to ground. Another circuit is through a part of the output transformer primary, down through a 1000-ohm resistor, and over to the left to the plates and screen grids of the other tubes. The filter is made up of the 30-mfd condenser connected from cathode to ground, part of the output transformer primary and 1000-ohm resistor, and the 40 mfd condenser connected from the output end of the resistor to ground. The plate of the 50L6 power output tube connects to the upper end of the output transformer primary. The cathodes of all except the rectifier tube connect to ground to complete the circuits to the grounded line wire.

The band switch at the left center of the diagram, is shown in the Broadcast position. Its contact No. 3, shown at the extreme left, connects to the grid of the r-f tube and to the stator of the antenna gang of the tuning

condenser. Contact No. 9, shown at the center of the switch, is coupled to the oscillator grid of the mixer tube and connected to the stator of the oscillator gang of the tuning condenser.

The loop, shown at the upper left, is mounted on the chassis and fits inside the cabinet. It acts as the antenna and also as the tuned secondary of an r-f transformer. One end of the loop connects through switch contacts 2 and 3 to the grid of the r-f tube, while as far as r-f is concerned, the other end is grounded through the .05-mfd condenser shown at the lower left and also connected to the lower end of the antenna coil secondary. The d-c grid bias is obtained by the voltage drop across the volume control in the circuit which continues from the lower left corner across the bottom, up and over through the 3 megohm resistor and volume control to ground.

The oscillator grid circuit is completed through contacts 9 and 8 of the switch, the padder condenser, and lower oscillator coil to ground. Both oscillator coil primaries are in series between the mixer tube cathode and ground.

Switch contacts 11 and 12 complete a circuit from ground through trimmer condenser B and the r-f choke to the control grid of the mixer tube. For this circuit, the values of inductance and

capacitance are chosen so that it can be tuned to resonance at the intermediate frequency of 455 kc. As the impedance of a series resonant circuit is minimum, this arrangement acts as a "trap" to short out any unwanted 455-kc frequencies which may be present in the input circuits, and prevents them from reaching the i-f amplifier.

Switch contacts 5 and 6 connect trimmer C across the oscillator gang of the tuning condenser to provide a high-frequency adjustment of the oscillator circuit.

When the switch is tuned to the "Short-Wave" position, contact 3 connects to contact 4, and the grid circuit of the r-f tube is completed through the secondary of the antenna coil to the d-c bias circuit. The signal frequencies are grounded by the .05-mfd. condenser connected to the lower end of the antenna coil secondary. The signal picked up on an external antenna, enters at the upper left terminal and is carried to ground through the primary of the antenna coil and the series connected .005-mfd condenser.

Through switch contacts 9 and 10, the oscillator grid of the mixer tube is coupled to the upper oscillator coil through the .005-mfd condenser, while contacts 1 and 12 short the lower primary and leave only the upper coil in the cathode circuit. Thus, the switch

operates to connect new coils in both the antenna and oscillator circuits, and although the circuits are tuned by the same two-gang condenser, the inductance of the new coils is such that the receiver responds to an entirely different band of carrier frequencies. In this particular circuit, the Broadcast band tunes from 540 kc to 1620 kc, while the Short Wave band tunes from 5.7 mc to 18.3 mc.

As the input circuit is tuned to much higher frequencies on the Short Wave band, when switch contact 12 connects to contact 1, it opens the trap circuit. Also, when switch contact 6 connects to contact 7, it opens the circuit of trimmer condenser C.

From the triode plate of the 12SQ7 tube there is a path through a .002-mfd condenser and switch to ground. This arrangement acts as a tone control because, in the switch position shown, the condenser provides a capacitive reactance path from plate to cathode. As capacitive reactance reduces at increased frequencies, in effect, the higher frequencies are shorted out of the 500,000 ohm plate load resistor, and therefore are not carried over to the grid circuit of the output tube. To the listener, this loss of the higher frequencies makes the low notes more pronounced.

On tracing the control grid

circuits of both 12SK7 tubes, they are seen to connect to ground through the 3-megohm resistor and the 500,000-ohm volume control. As will be explained in a following Lesson, the voltage drop across the volume control is thus impressed also on these grid circuits. However, the 3-megohm resistor in conjunction with the .05-mfd condenser shown at the lower left, operates to provide the grid circuits with a d-c voltage, the amplitude of which varies as the average strength of the demodulated i-f. As the polarity of this voltage is negative toward the grids, an increase of signal strength increases the negative grid bias which accordingly reduces the signal and provides automatic volume control. To improve the stability of the oscillator, the 3-megohm resistor connects through a 10-megohm resistor to the oscillator grid.

## ALL-WAVE RECEIVERS

All-wave receivers are similar to the type shown in Figure 11, but three or more sets of coils are provided and connected into the proper circuits by the Band Switch. When a tuned r-f amplifier stage is used, three coils are needed for each set or band, and the tuning condenser requires three gangs. However, for each position of the band switch, the circuits are essentially the same as explained in this Lesson.

**IMPORTANT WORDS USED IN THIS LESSON**

**ALL-WAVE**—A term commonly applied to radio receivers that are designed to tune over a range from 550 kilocycles to about 20,000 kilocycles.

**BEAT FREQUENCY**—One of the two new frequencies resulting when two different basic frequencies are combined.

**CONVERTER**—That portion of a superheterodyne receiver in which the incoming r-f signal is reduced to a lower intermediate frequency. The converter includes the 1st detector and oscillator stages.

**FIRST DETECTOR**—That portion of a superheterodyne receiver in which the incoming signal is combined or heterodyned with the local oscillator signal. Also known as the mixer.

**HETERODYNE**—Pertaining to the generation of beat frequencies by combining two basic frequencies.

**IMAGE FREQUENCY**—A frequency that is above the incoming signal frequency in a superheterodyne receiver by twice the intermediate frequency.

**INTERMEDIATE FREQUENCY**—The main operating frequency in a superheterodyne receiver. It results from the combining of the incoming r-f signal with a local oscillator signal, and usually is equal to their difference.

**OSCILLATOR**—That portion of a superheterodyne receiver in which the local signal frequency is generated. The oscillator frequency combines with the incoming frequency to produce the difference or intermediate frequency.

**PADDER**—A small condenser connected in series with the oscillator section of the main tuning condenser to provide a constant difference frequency and to maintain the calibration of the receiver, particularly at the low-frequency end.

**SECOND DETECTOR**—That stage in a superheterodyne receiver in which the intermediate-frequency carrier is demodulated and the transmitted signal is made available for aural reproduction.

**TRIMMER**—A small variable condenser often connected across the main tuning condenser gangs to compensate for small variations of capacitance due to circuit wiring, etc., particularly at the high-frequency end.

**TRIODE-HEXODE**—A composite tube consisting of a triode and hexode combined into one structure, and designed for converter service in superheterodyne receivers.



STUDENT NOTES

STUDENT NOTES

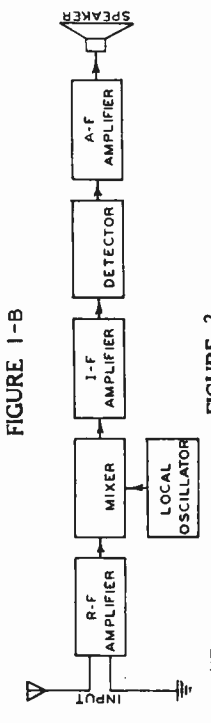
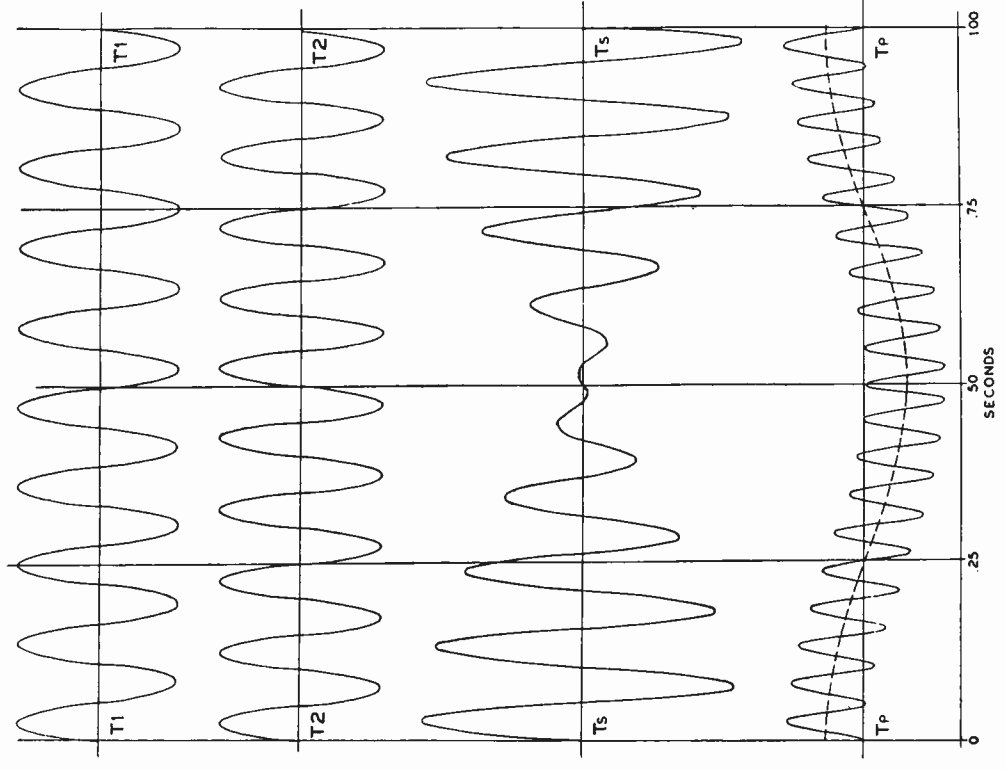
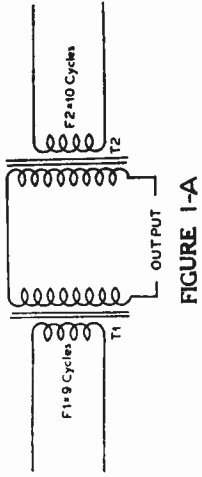

FIGURE 2

"RRT-9"

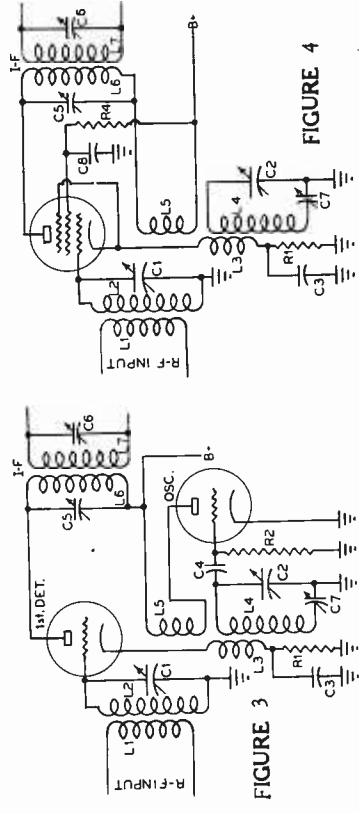

FIGURE 3

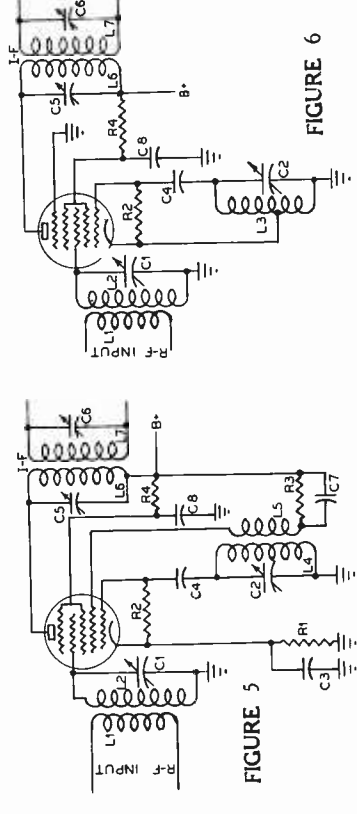

FIGURE 4

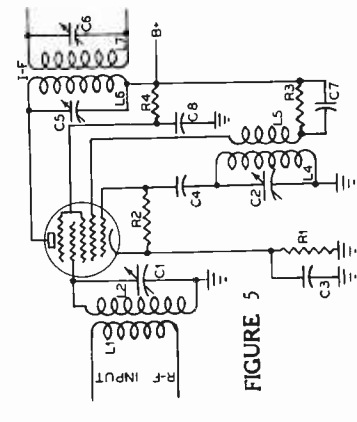

FIGURE 5

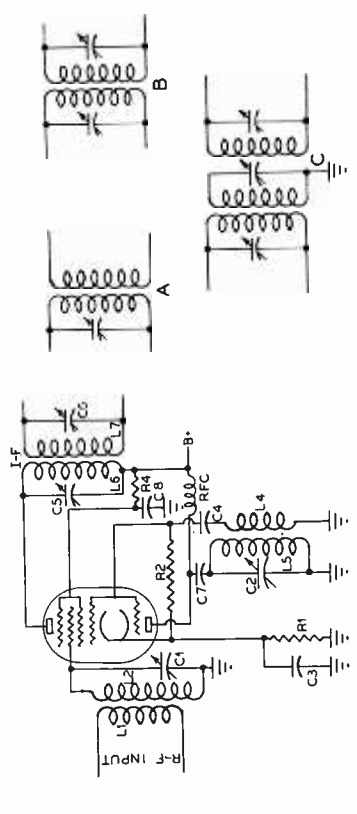

FIGURE 6

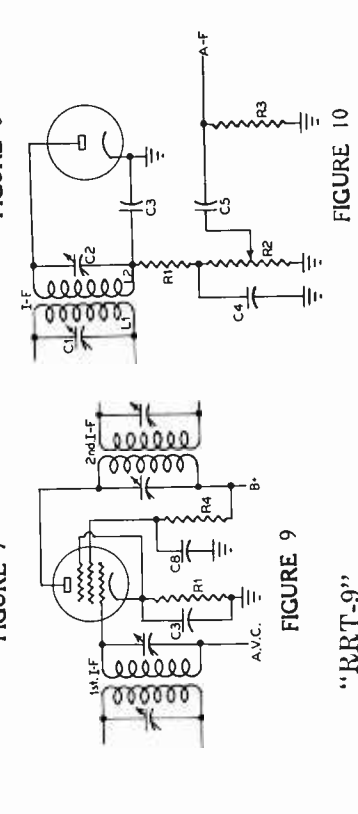

FIGURE 7

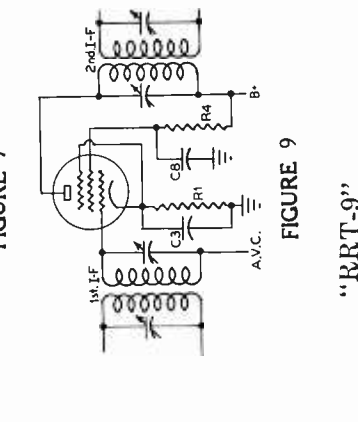

FIGURE 8

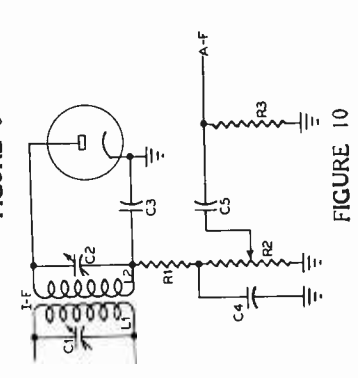

FIGURE 9

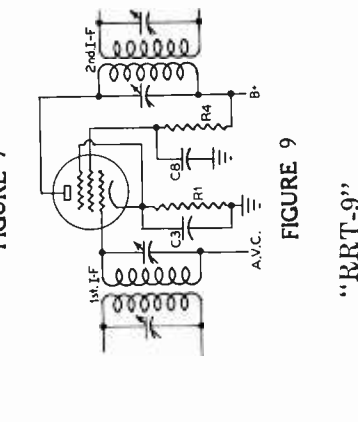

FIGURE 10

"RRT-9"

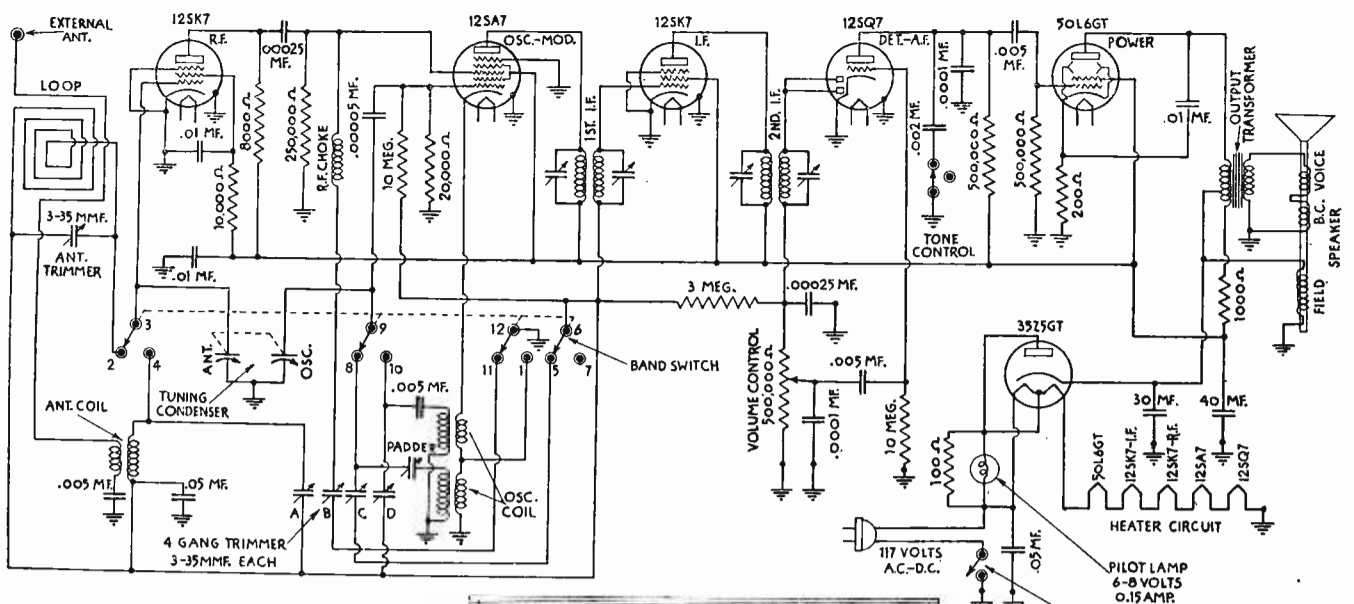
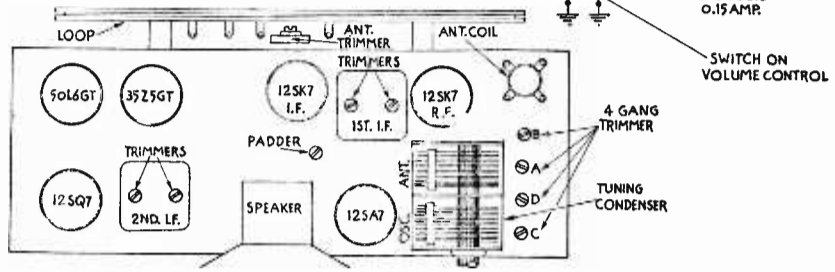

FIGURE 11

"RRT-9"







## FROM OUR *President's* NOTEBOOK

### MY OBJECTIVE

To make myself ready, so that Opportunity will not pass me by.

To stir my mind with effort.

To do the rational things without being told.

To make every hour bring increased knowledge, and never let time find me idle.

To study my profession with unremitting zeal.

To convert practice and experience into capital stock for future use.

To be honest and generous.

To banish a morose temper for one bright and equable.

To attain an agreeable personality, and be esteemed.

To be gentle both to my superiors and to my inferiors.

To make the most of myself with the hope of achieving the greatest of all rewards—a good conscience.

Yours for success,

*E. B. Selby*

PRESIDENT