

ALTERNATING CURRENT  
SINE WAVE

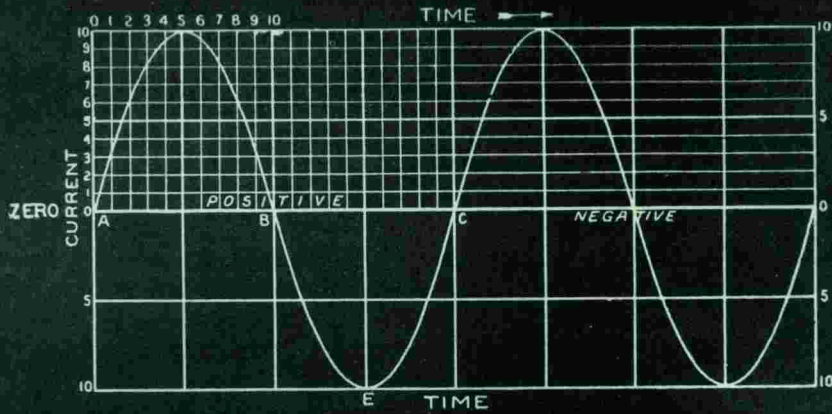

**LESSON  
65**

# ALTERNATORS AND A.C. CIRCUITS



# RADIO-TELEVISION TRAINING SCHOOL, INC.

5100 SOUTH VERMONT AVENUE • LOS ANGELES 37, CALIFORNIA, U. S. A.

## ALTERNATORS AND A.C. CIRCUITS

An alternating current, like every other form of electrical current, is merely a movement of electricity through a conductor, and its distinguishing feature is the pulsating manner in which it flows through the circuit. An alternating current periodically (at regular short intervals) reverses its direction of flow. It begins at zero, increases to a maximum value, and then decreases to zero again; and at the instant it reaches zero it reverses and once more rises to the maximum value (but of course in the opposite direction) and then decreases to zero. It repeats the same process over and over. The complete set of values through which an alternating current passes successively is known as a cycle, and the number of such cycles completed in a second is known as the frequency. The alternating current commonly used in our house lighting circuits has a frequency of 60 cycles per second. In order to cause such an alternating current to flow through a circuit, an alternating voltage or electromotive force of the same nature and frequency must be impressed across the terminals of the circuit.

An alternating current and an alternating voltage are always represented graphically by means of a curved line such as is illustrated in Fig. 1.

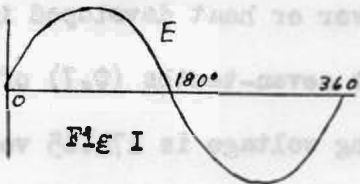

Mathematically the line is known as a sine curve. But it should not be imagined that an alternating current flows through a wire in such a wavy manner, the curved line merely illustrates the current strength at every instant. Distances above the line represent the current flow in one direction and distances be-

low the line current flow in the opposite direction.

The strength of an alternating current is measured in amperes with an instrument called an ammeter just as direct currents are, and alternating pressures are also measured in volts with a voltmeter. When an alternating current flows through a conductor it also encounters the resistance of the conductor, and in overcoming this resistance heat is developed. A voltage drop also occurs. But in addition to these three factors there are several other conditions present in alternating current (A.C.) circuits, as we shall presently see; and it is these additional factors which render the operation of A.C. circuits somewhat more complex. But there is a definite relation existing between all these factors; and once this relationship is clearly seen, the study of A.C. circuits is no more difficult than that of the D.C. circuits.

#### EFFECTIVE VALUE OF AN ALTERNATING CURRENT

The value or strength of an alternating voltage (or current) is constantly changing; and if a definite pressure is designated, such as 120 volts, it is necessary to define just what is meant by this value. Three values of an alternating voltage (or current) are commonly spoken of--the maximum value, the average value, and the effective value; but of these the effective value is the only one used commercially, for, as its name suggests, it is the actual value that is useful in determining the power or heat developed in an A.C. circuit. The effective value is equal to about seven-tenths (0.7) of the maximum value. If the maximum value of an alternating voltage is 171.15 volts, the effective value is  $171.15 \times 0.7$  or 120 volts. If we know the effective value and wish to obtain the maximum value, it is necessary to multiply by ten-sevenths ( $10/7$ ths); i.e., if the effective value of an alternating current is 35 amperes; the maximum (or peak) value is equal to  $35 \times 10/7$  or 50 amperes. If an A.C. lighting circuit is rated at 120 volts, this means that the effective value of the



pressure is 120 volts, but that the pressure really varies from zero to a maximum of 171.15 volts in each direction.

All alternating current measuring instruments are calibrated so as to read directly in effective values, and we need not worry about making any complicated calculations when making A.C. measurements. In commercial practice the average or maximum values are never used; and when a certain voltage or current strength is referred to, it is always understood that the effective value is meant.

Power in alternating current circuits is measured in watts or kilowatts (1000 watts); but as we shall presently see, a third factor known as the "power factor" is used in making A.C. power calculations.

#### ALTERNATING CURRENT GENERATORS

Alternating current generators, also frequently called alternators, embody the same general principles in their construction and operation that direct current generators do. Their operation is based on electromagnetic induction; i.e., when a group of conductors is cut by magnetic lines of force, there is induced in the conductors an electromotive force or electrical pressure. If these conductors comprise coils of wire rotating in a magnetic field, the induced E.M.F. is in one direction during one-half of the revolution and in the other direction during the other half of the revolution. In other words, there is produced an alternating voltage in the coils. In a D.C. generator, a commutator is used to change or rectify this alternating current and to deliver a direct current to the external circuit. An A.C. generator does not employ a commutator, but delivers an alternating current.

Alternating current generators, therefore, also consist of three essential parts: an electromagnetic field structure which produces the magnetic line of force, an armature provided with a group of coils to cut these lines of force, and a device for connecting the internal circuits of the machine to the external distribution circuits. According to the arrangement of the armature and

field structures, alternators are classified as rotating field and rotating armature machines.

Rotating-armature alternators are very similar in construction to direct current generators, and consist of a stationary frame with the field poles projecting from the inner surface, while at the center rotates the armature in the form of a cylindrical core with the windings imbedded in slots in the surface. The winding is tapped at two diametrically opposite points and connected to a pair of brass or bronze rings mounted on but insulated from the rotating shaft. On these "slip-rings" slide a pair of brushes by means of which connection is made to the external circuit. The field coils are excited by direct current supplied by a small DC generator or storage battery. Alternating current cannot be used for excitation because a magnetic field of constant strength is necessary, and this can be produced only with direct current. The armature of some machines are provided with a double winding, one the A.C. winding brought out to the slip rings, and the other a D.C. winding brought out to a commutator and used for supplying the direct current to the field circuits. Such machines are completely self-contained. Revolving-armature alternators are used only in small sizes and up to about 600 volts pressure. They are very compact, and if properly operated and attended to give very efficient service.

#### REVOLVING-FIELD ALTERNATORS

All larger capacity and high voltage alternating current generators are of the revolving field type. In these machines the armature conductors instead of being laid in slots in the surface of the rotating cylinder, are wound in slots on the inner surface of the stationary frame. The field poles in turn are mounted on the rotating shaft. The armature terminals are then brought out directly from the stationary winding, while the terminal leads of the field winding are connected to a pair of slip-rings mounted on the shaft. Through these slip-rings the exciting current is supplied to the field windings. These

parts are all clearly illustrated in the alternator shown in Fig. 1A.

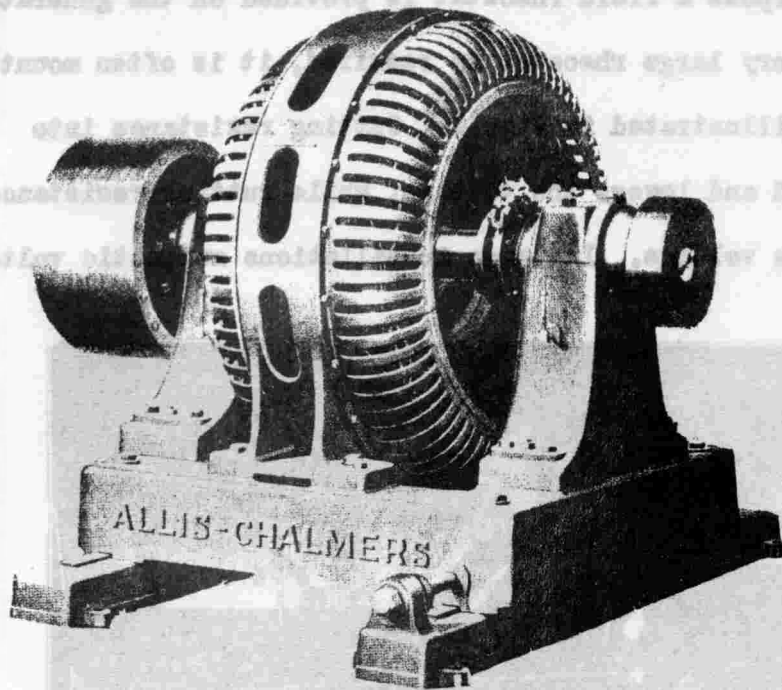

Fig 1A

The advantage of this arrangement is that large currents at high voltages need not be taken off or transmitted from any rotating rings, the only current being transferred is the small exciting current supplied to the fields, and this is comparatively low voltage.

The stationary frame together with the armature windings imbedded in the inner surface is known as the stator (derived from the word stationary), and the rotating field structure is known as the rotor. Alternators driven by a steam engine as illustrated in Fig. 2 are generally large in diameter, for then the rotation of the heavy field structure tends to keep the motion more steady and uniform. Generators driven by steam turbines and known as turboalternators are smaller in diameter due to the high speeds at which they are operated.

#### VOLTAGE AND FREQUENCY OF THE INDUCED E. M. F.

The voltage of an alternating current generator like that of a direct current machine, depends upon three factors: The number of coils connected in series in the armature winding, the strength of the magnetic field, and the speed of rotation. Since the speed of rotation must be held steady in order to maintain

a constant frequency, the only means of varying the voltage is by changing the field strength. For this purpose a field rheostat is provided on the generator control switchboard. If a very large rheostat is required, it is often mounted above the switchboard as is illustrated in Fig. 2. Cutting resistance into the circuit weakens the field and lowers the voltage, while cutting resistance out of the circuit raises the voltage. In large installations automatic voltage regulators are employed.

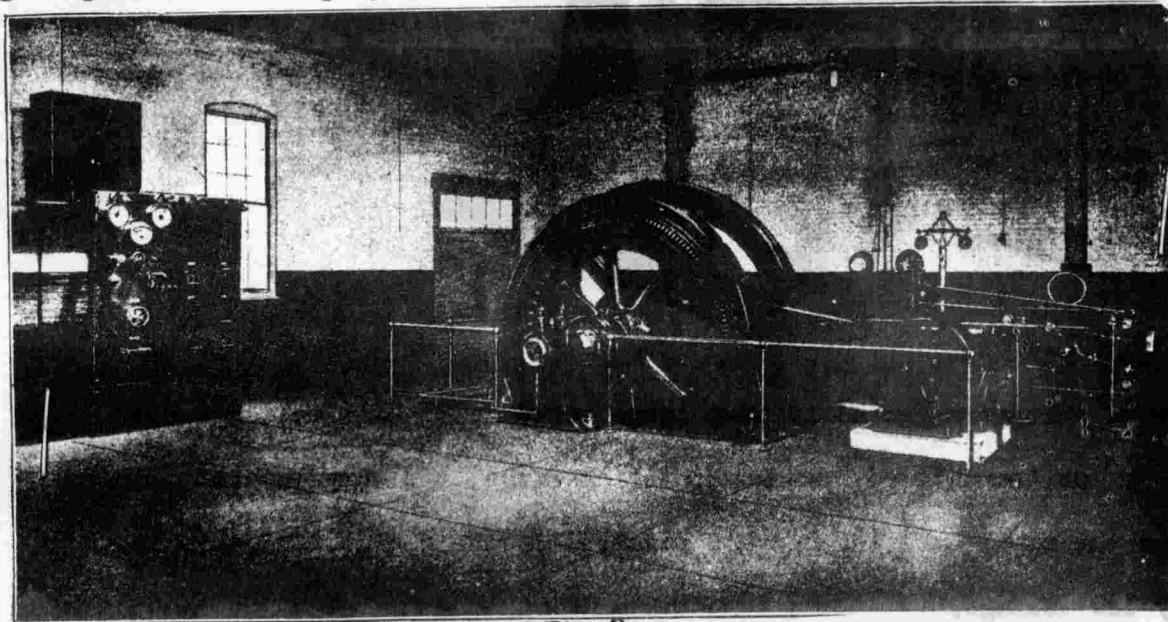

Fig 2

The frequency of the induced voltage, that is the number of cycles per second depends only on the speed of rotation and the number of field poles. The strength of the field poles has nothing to do with the frequency. Since one cycle is the complete set of values through which the voltage passes successively, every time an armature coil passes a N and S pole and cuts the lines of force coming from them, one cycle will be induced. If the machine has 4 poles and makes one revolution per second, the frequency will be 2 cycles per second; and if the same machine makes 5 revolutions per second, the frequency will be 10 cycles per second. Therefore, to calculate the frequency we need merely multiply the number of pairs of poles by the revolutions per second. If the speed of the machine is expressed in revolutions per minute (abbreviated R.P.M.)



we must divide by 60 to obtain the revolutions per second. We thus have the following general formula:

$$\text{Frequency} = \frac{\text{No. of poles} \times \text{R.P.M.}}{2 \times 60}$$

Example: To determine the frequency of a 16-pole alternator operating at a speed of 450 R.P.M.

$$\text{Frequency} = \frac{16 \times 450}{2 \times 60} = 8 \times 7\frac{1}{2} = 60 \text{ cycles per sec.}$$

It is also evident from the above that an alternator in order to generate a voltage of a certain frequency must be operated at a definite speed depending upon the number of field poles in its structure. This speed can always be calculated by changing the above formula into the following form:

$$\text{Speed} = \frac{60 \times \text{Frequency}}{\text{No. of pairs of poles}}$$

Example: To determine at what speed a 10-pole alternator must be operated in order to develop a frequency of 25 cycles per second.

$$\text{Speed} = \frac{60 \times 25}{5} = 300 \text{ R.P.M.}$$

Numerous alternating current machinery depends for its successful operation upon an alternating current supplied to it at an absolutely constant frequency, and it is very necessary that an alternator be driven at a constant speed so as to develop a steady frequency.

#### EXCITERS

As was previously stated, direct current must be used for exciting the field magnets of alternating current generators. This direct current is nearly always supplied by means of small direct current generators known as exciters. On some machines these exciters are mounted directly on the same shaft as the rotor of the alternator, as is illustrated in Fig. 1A, while in other cases as in the installation shown in Fig. 2, the exciter is driven by means of a belt from a pulley mounted on the alternator shaft. In very large installations a



single independently driven exciter is used to supply the direct current to a group of alternators. These exciters are operated like any direct current generator, and in the smaller sizes are generally shunt machines.

#### OPERATING A SINGLE ALTERNATOR

The installation illustrated in Fig. 2 is a typical alternating current generating system, with the switchboard and control equipment mounted to the left of the machine. The alternator is of the revolving field type and is driven by means of a reciprocating steam engine. The exciter is a 4-pole D.C. generator connected by means of a belt to the main generator shaft. The electrical connections from the machines to the switchboards run below the floor.

The switchboard consists of two panels, a generator and a distribution panel. On the generator panel are mounted the necessary instruments and control switches. The exciter field rheostat is mounted on the rear of the panel and has the control knob on the front of the board directly below the center meter. On the right of the panel is the switch for opening the field circuit of the alternator. The alternator field rheostat is shown mounted above the board and operated by means of a chain which extends down to the large control wheel near the center of the panel. The large switch at the bottom is the main switch and connects the generator to the distribution circuits on the right hand panel.

Before an alternator is put into operation, first see that everything is clear, that the oil wells are properly filled, and that all switches on the board are open. The machine is then started and slowly brought up to speed. The exciter voltage is next adjusted to normal value by means of the exciter rheostat. The field switch is now closed and the alternator voltage brought up by means of the main rheostat. Lastly the main line switch is closed which connects the generator to the distribution panel on the right. As power is needed on any of these circuits, the corresponding switch is closed.

To shut down an alternator, the entire load is first taken off; and after

all resistance has been cut into the field rheostat, the field switch is opened. The exciter voltage is next brought down, and lastly the machine is shut down by cutting off the driving power.

### RESISTANCE, REACTANCE AND IMPEDANCE

An alternating E.M.F. is generally represented by a wave, as shown in Fig. 3, called a sine curve, a term derived from a branch of mathematics known as trigonometry. This represents one complete cycle and is said to consist of 360 electrical degrees, for it is developed when a simple 2-pole alternator makes one complete revolution of 360 degrees. Each point on the curve represents a certain number of degrees from the starting point indicated by O. The first maximum value is reached at  $90^\circ$ , and the curve passes through zero at  $180^\circ$ . The next maximum is reached at  $270^\circ$ , and at  $360^\circ$  the cycle is completed. Any intermediate point, of course, represents a corresponding number of degrees.

If this alternating E.M.F. is impressed across the terminals of a circuit, it causes an alternating current of the same frequency to flow; and if the circuit contains only resistance, the current will pass through its zero and maximum values at the same instance that the applied voltage does. Under these conditions the current is said to be "in phase with" (meaning in step with) the voltage, and the strength of the current is limited only by the value of the voltage and the amount of resistance experienced (Ohm's Law). In Fig. 4 are shown the voltage and current curves for an alternating current circuit containing only resistance. The current is shown in phase with the voltage.

Practically all alternating current circuits offer in addition to resistance another form of opposition known as reactance. This reactance is a result of the inductance or capacity of the circuit, and in the one case it is known as inductive reactance and in the other as capacity reactance. Reactance is represented by the capital letter X. Each form of reactance sets up a counter-voltage which hinders the flow of current and causes a drop or decrease in the

applied voltage.

Another effect caused by inductance in an A.C. circuit is that it throws the voltage and current out of phase (out of step). For example, when a coil is connected into an A.C. circuit, the applied voltage causes a current to flow through it. As the current rises, it builds up a magnetic field around the coil, and in doing so it is delayed in reaching its maximum value. Then as the current decreases, the magnetic field collapses and tries to maintain the flow of current. As a result the current reaches its zero value later than if no inductance were present. Irrespective of how much or how little inductance is in the circuit, this delaying action is always present. Consequently, inductance in an alternating current circuit causes the current to reach its maximum and zero values after the voltage has passed through them. In other words, the current is caused to lag behind the voltage.

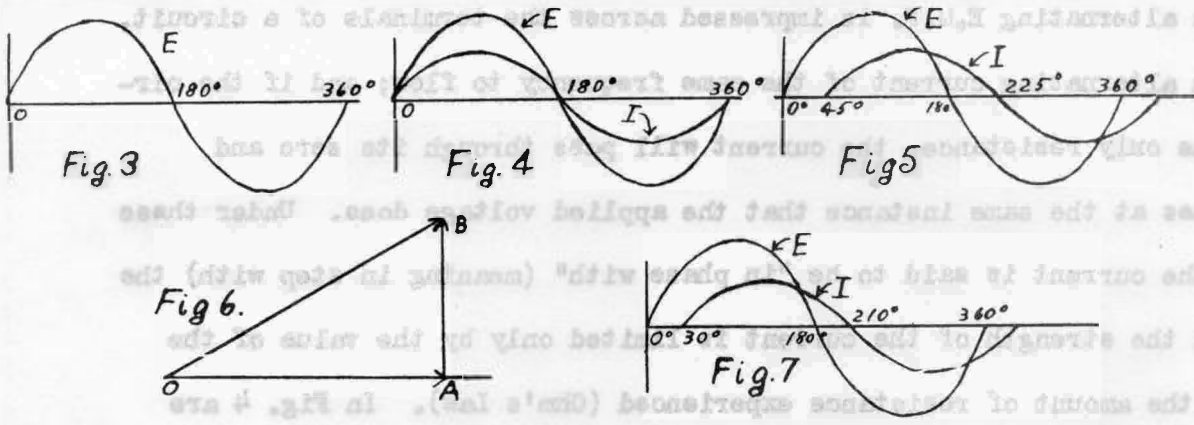

If a circuit contained only inductance, the current would reach its maximum value when the voltage was passing through zero, that is, the current would lag 90 degrees (one-fourth cycle) behind the voltage. But since there is always some resistance present in a circuit as well as inductance, the combined effect causes the current to lag by some amount between 90 and 0 degrees. With little inductance in the circuit the current lag is small, but with high inductance the lag is very great. In Fig. 5 are illustrated the conditions in an inductive A.C. circuit. Here the current lags 45 degrees behind the voltage.



Capacity in an alternating current circuit, on the other hand, causes the voltage to lag behind the current. The condenser action of the circuit produces a retarding effect on the voltage, and sets up a leading current in the circuit. Inductance and capacity produce opposite effects, and if the two are just equal, they neutralize each other, and resistance is then the only opposition the current experiences. When such a condition exists, the circuit is said to be in resonance. The opposition the current experiences due either to the inductance or capacity of a circuit is called the reactance and is measured in ohms just like resistance is.

In an A.C. circuit there are two opposing effects, resistance which is direct or in phase with the current, and reactance which is  $90^\circ$  out of phase (at right angles) with the current. Since both are a form of opposition, they are both measured in ohms. The combined effect of the resistance and reactance is called the "impedance" of a circuit. Impedance of course is also measured in ohms. Resistance, reactance, and impedance may be considered as the three sides of a right triangle as in Fig. 6. Here the length of the horizontal OA represents 8.66 ohms resistance, and the vertical arrow at right angles to the resistance AB represents 5 ohms reactance. The combined effect of these two is then represented by the arrow OB which represents the impedance. To find the value of OB it is necessary to square (multiply by itself) the 8.66 and the 5 and then extract the square root of the sum. Thus  $8.66 \times 8.66$  equals 75, and  $5 \times 5$  equals 25. The sum is 100 and the square root of 100 is 10, which is the value of the impedance. The angle which the impedance arrow OB makes with the horizontal is the angle (no. of degrees) by which the current lags behind the voltage. In this case it is equal to 30 degrees. The corresponding voltage and current curves are illustrated in Fig. 7.

To calculate the current flowing in an A.C. circuit we divide the applied voltage by the impedance according to Ohm's Law. Thus:

$$\text{Current} = \frac{\text{Applied Voltage}}{\text{Impedance}} = \frac{E}{\sqrt{(\text{Resistance})^2 + (\text{Reactance})^2}} = \frac{E}{\sqrt{R^2 + X^2}}$$

### POWER AND POWER FACTOR IN A.C. CIRCUITS

If an A.C. circuit contains only resistance and no inductance, then the power is calculated as in D.C. circuits by multiplying the volts by the amperes, and power then being expressed in watts.

However, if the circuit contains some inductance also, then the entire applied voltage is not effective in developing power, but part of it is used in overcoming the reactance of the circuit, that is the inductance and capacity effects. The product of the volts and amperes would then be called the apparent power, (the power that appears to be), and to get the true power the apparent power must be multiplied by a certain fraction. The fraction by which the product of the volts and amperes of an A.C. circuit must be multiplied to give the true power is called the power factor. The power factor is always less than 1, and its value depends upon the angle of lag of the current behind the voltage. It is generally expressed in per cent. The power factor of a circuit can be measured with a recently developed instrument known as a power factor meter. It is always expressed in per cent.

To calculate the power of an A.C. circuit in which the current is out of phase with the voltage, we must multiply three quantities together, the volts amperes, and power factor.

$$\text{A.C. Power} = \text{Volts} \times \text{Amperes} \times \text{Power Factor}$$

**Example:** What is the power expended in an A.C. circuit in which the pressure is 120 volts and a current of 5 amperes flows, the power factor being 80%?

$$\text{Power} = 120 \times 5 \times 80\% = 480 \text{ Watts.}$$

### SINGLE AND THREE-PHASE SYSTEMS

Alternating current systems such as have just been discussed and in which

but one alternating voltage is in operation are known as "single-phase" systems meaning single acting. These systems are used in house lighting circuits, and all small power systems.

Where large quantities of A.C. power are developed or consumed, it is more economical to employ three-phase systems (meaning triple-action). In a three-phase system there are really three single phase voltages in operation, all three being of the same value but differing in phase from each other by 120 electrical degrees, or one-third of a cycle. A three-phase system is equivalent to three single phase circuits, and by a special arrangement of the electrical connections the number of line wires can be reduced to three. As a result of these economies in generation and distribution, three-phase systems have numerous advantages and are now used almost exclusively in all larger capacity A.C. power systems.

#### THREE-PHASE ALTERNATING CURRENT GENERATORS

A three-phase alternating voltage can be developed by means of three interconnected single-phase generators or by one three-phase generator. The latter method is used in all commercial practice. A three-phase generator is in all respects similar to a single-phase machine, except that it has three complete and independent armature windings spaced 120 electrical degrees apart. This means that if the beginning of the first winding lies directly below the center of a north pole, the beginning of the second winding would just about be entering the next south pole (in other words, the two windings would be separated by an amount equal to one-third the distance between the centers of two adjacent north poles). The beginning of the third winding would then be the same distance ahead of the second winding. Since the distance between the centers of two adjacent north poles is equal to 360 electrical degrees, for a winding must move through this distance in order to have one complete voltage cycle induced in it, the three windings of a three-phase system are said to be 120 degrees



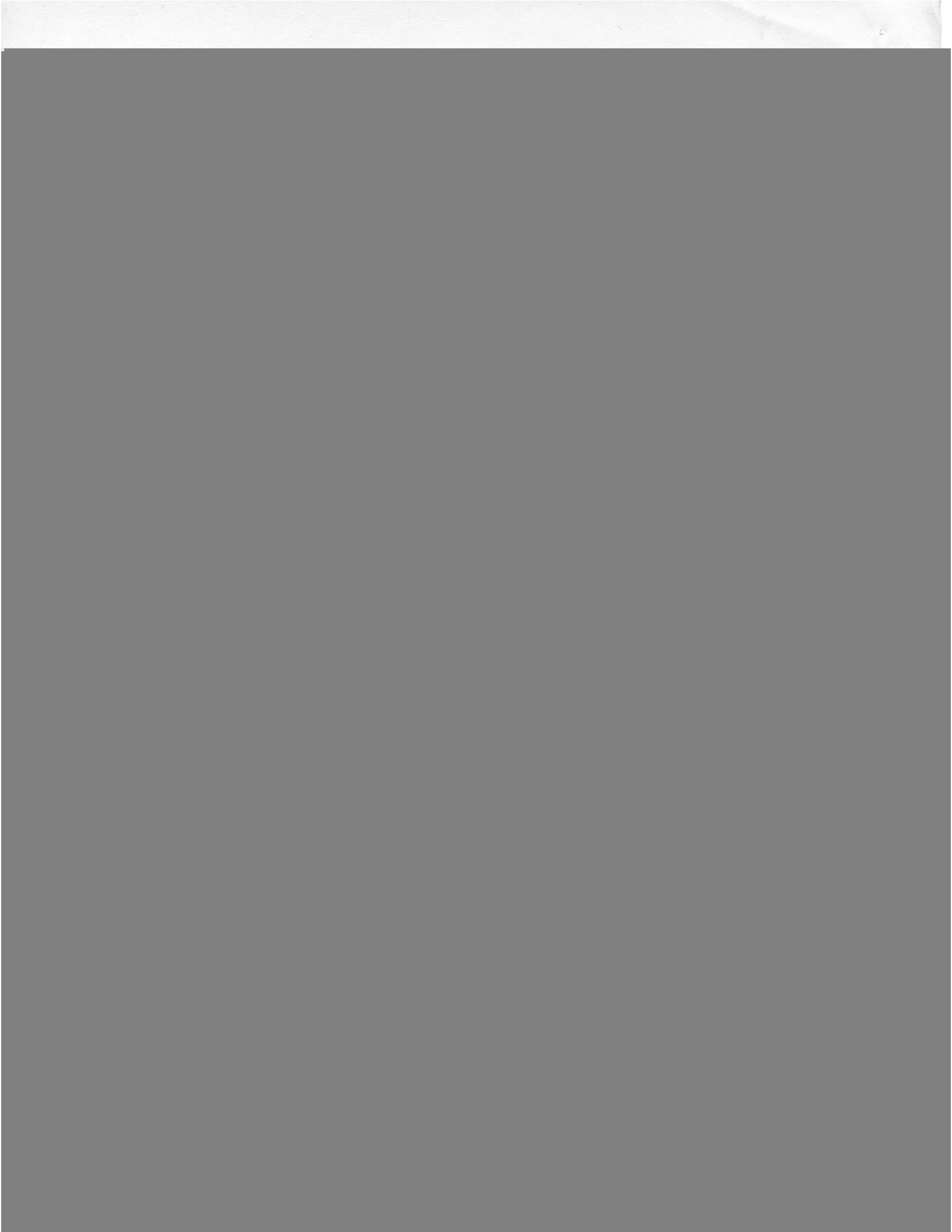

of phase by the same amount.

In order to save wire so that only three terminal leads need be brought out of the generator, two methods of interconnecting the three windings are employed. One of these is known as the Y or star connection, and the other as the delta connection. Most machines, however, have their windings connected in star. To effect this connection the beginnings or inner ends of the three windings are joined together as shown in Fig. 11. There are only three line wires coming out of the machine, and these three can be used as a 3-phase system or they can be used for operating three single-phase systems. To operate a single-phase circuit from a 3-phase system it is only necessary to connect the two leads across any pair of the 3-phase wires.

The delta connection illustrated in Fig. 12 is made by connecting the end of the first winding to the beginning of the second, the end of the second to the beginning of the third, and the end of the third to the beginning of the first again. There is a completely closed circuit formed, but since the three voltages are 120 degrees out of phase, the sum of any two will be exactly equal to but opposite to the third, and the total resulting voltage in the ring is equal to zero. No current will flow in the ring, unless the currents and voltages are out of phase with each other.

By carefully observing Figures 11 and 12, it can readily be seen that in any 3-phase system (either star or delta) one of the line wires always serves as a return circuit for each of the other two. For example, in Fig. 6, wire No. 1 acts as a return for 2 and 3, No. 2 acts as a return for 1 and 3, and No. 3 acts as a return for 1 and 2. Another way of stating this is that at any instant the current is flowing away from the generator in two of the wires and returning through the third one, the combination changing every third of a cycle.

#### LOADING A THREE-PHASE CIRCUIT

A 3-phase circuit can be loaded in three different ways: either one, two

or three single-phase loads can be added to the system as shown at A in Fig.

13, a star-connected load can be added to the system as at B in the figure, or

a delta-connected load can be added as at C.

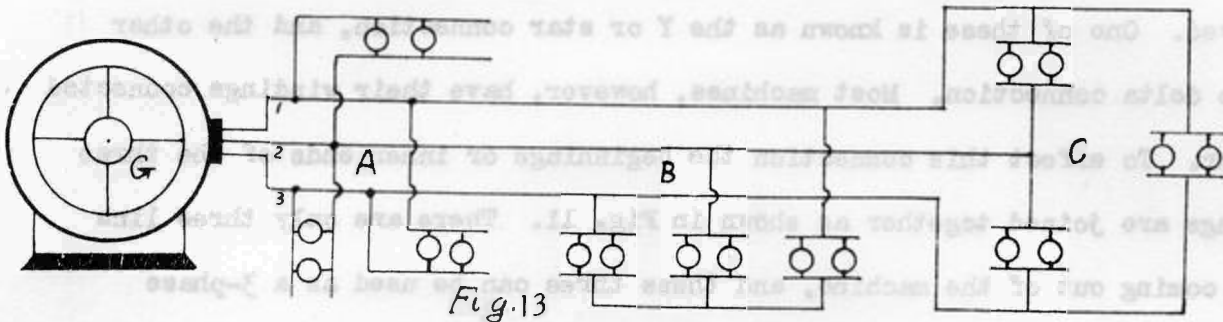

Fig. 13

The power consumed by the load at A is of course the sum of the three single-phase loads; and if the power factor is 100% or unity (voltage and current are in phase), the power of each load is then equal to the volts times the amperes, and the total power is the sum of the three.

With a 3-phase load the power is calculated in a different manner. If the amount of the load on a 3-phase system is the same in each branch, the system is said to be balanced. To calculate the power consumed by a 3-phase load it is necessary to multiply the phase voltage by the line current and the power factor, and lastly by the numerical factor 1.73. The general formula is:

$$\text{3-Phase Power} = 1.73 \times E \times I \times \text{P.F. (ans. in watts).}$$

Example: to calculate the amount of power consumed by a 3-phase motor drawing 15 amperes from a 240-volt, 3-phase system, the power factor being 80%.

$$\text{Power Consumed} = 1.73 \times 240 \times 15 \times 80\% = 4982.4 \text{ Watts.}$$

The same formula is used, whether the load is connected in star or in delta--- E is the voltage across any two of the line wires while I is the current flowing in the line wires. The power factor can always be measured with a power factor meter.