



Electronics

Radio

Television

Radar

UNITED ELECTRONICS LABORATORIES

LOUISVILLE

KENTUCKY

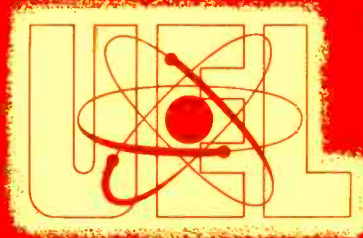

REVISED 1967

COPYRIGHT 1956 UNITED ELECTRONICS LABORATORIES

POWER SUPPLIES

ASSIGNMENT 23

POWER SUPPLIES

In previous assignments we have learned that d-c voltages are required for the operation of transistor and vacuum-tube circuits. The commercial power supplied to almost all communities is alternating current. Thus, electronics equipment must incorporate a means of converting a-c to d-c, if this equipment is to operate from commercial power. The circuits which change the commercial a-c into d-c voltages for operation of electronics equipment are called power supplies.

In the early days of radio, most equipment (both receiving and transmitting) depended upon batteries to supply the power needed. The source of filament voltage was called the "A" battery, the source of plate voltage was called the "B" battery, and the source of grid voltage was called the "C" battery. For radio receivers, a single storage battery or several dry cells supplied the filament power for the tubes. If the voltage was too high, it was dropped to the proper value with an adjustable rheostat. In these earlier receivers, the plate voltage was obtained from several "B" batteries connected in series. A single "B" battery consists of 30 small dry cells connected in series to give 45 volts, and two such "B" batteries in series would give a total of 90 volts. Many of these receivers required either 135 or 180 volts plate voltage, necessitating the use of three or four "B" batteries. The current flow from a battery is smooth, as it has no ripple or other variations. The uniform flow of power is one of the desired characteristics of batteries. However, batteries are capable of delivering only a limited amount of energy and must be either recharged or replaced periodically. Also, as a battery discharges, the voltage delivered decreases and eventually causes unsatisfactory operation of the equipment. Other disadvantages of batteries are their high cost, weight, bulk, and damage to clothing and equipment from spilled acid. Battery power is more expensive; also, it is less convenient than power that can be obtained from the ordinary lighting circuits, except, of course, in the case of portable equipment.

Transmitters use a great deal of plate power, so the batteries used for this purpose had to be replaced quite often. Sometimes a d-c generator or dynamo was used to produce a voltage of the proper value, and after the ripple was removed by filtering, this worked as well as batteries. The generator was either gas driven or driven by an electric motor operating from the 110 volt a-c supply line. This method, although still in use in some electronics equipment, is heavy, bulky, and rather inefficient; but does permit operation of vacuum-tube circuits from the 110 volt a-c line.

The indirectly heated cathode type tubes were especially developed so that the "A" battery could be eliminated and alternating current could be used to heat the cathodes of the vacuum-tube. The cathode type heater construction permits alternating-current operation and reduces or eliminates the hum which resulted when the earlier type of directly heated filament

tubes were used with a-c filament voltage supplies. This hum was partly produced by the filament heating up and cooling down many times per second as the a-c filament supply periodically increased and decreased. By making the electron emitting cathode large and separate from the heating element, a great deal of the heat is retained and the temperature is kept fairly constant while the a-c filament voltage continually changes in magnitude through the variation of the alternatnig cycle. This explains why it is necessary to wait twenty or thirty seconds after turning on a vacuum-tube radio for the heaters to heat the cathodes sufficiently to cause the emission of electrons necessary to make the radio play.

As can be seen, the need was for a power supply which would operate from a-c voltages such as are supplied by most power companies, and which would provide the required d-c plate power to replace the inconvenient and expensive "B" battery. Such a unit, together with the indirectly heated a-c type tubes, would enable radio or electronics equipment to operate directly from the usual source of power—110 volts a-c. Such a power unit was made possible through the use of a diode type vacuum-tube. The process of changing alternating current into direct current is called **rectification**.

Rectification

Figure 1 shows the block diagram of a typical power supply for electronics equipment using vacuum-tubes. Let us consider this block diagram to obtain an overall picture of the operation of a rectifier type of power supply, and then we will consider each component in detail. As can be seen from this figure, the 110 a-c is applied to the input of this power supply. In the power supply are two transformers, the plate transformer and the filament transformer. (In most cases, these two transformers are incorporated in one unit.) The filament transformer supplies the low voltage for the filaments of the tubes in the equipment. The plate transformer is usually a step-up transformer, that is, it steps up the a-c voltage (usually 110 volts) to some higher value of voltage. The exact amount of voltage is dependent upon the type of equipment with which the power supply is to be used. This high value of a-c voltage is then fed to the rectifier tube. This rectifier tube changes the alternating current into pulsating d-c current as shown in Figure 1. Notice that this current is direct-current, that is, it is flowing only in one direction. However, it is pulsating, or varying, in amplitude. If this pulsating direct-current were used for the plate voltage supply for the vacuum-tubes in a radio receiver, nothing would be heard from the loud speaker but a loud hum. This is because the vacuum-tubes must have a nearly pure d-c applied to them. The purpose of the filter in the power supply is to change this pulsating d-c into an almost pure d-c, with very little ripple.

Figure 1 illustrated the overall picture of the power supply. Now let us consider each individual component in the power supply. Figure 2 shows the schematic diagram of a power transformer with a load across the H. V.

SECONDARY composed of the resistor R_L . In this particular case, the transformer shown has three secondary windings. The secondary winding, labelled H. V. SECONDARY, is the winding which supplies the high a-c voltage to be rectified by the rectifier tube and changed into d-c. The low voltage secondary winding for the rectifier filaments supplies the electrical energy for heating the filament or heater of the rectifier tube. The third secondary winding supplies the low voltage for the filaments or heaters of the other tubes in the equipment. In Figure 2, notice, also that there is a resistor R_L connected across the high voltage secondary winding of the power transformer. This is not a customary connection in a power supply, but is shown here to explain its operation. When alternating current flows through the primary of the power transformer, an alternating voltage is induced into each secondary winding. Since an alternating voltage is induced in the high voltage secondary winding, an alternating current will flow through the load resistor R_L . The graph in Figure 2(B) shows the alternating voltage which appears across the load resistor R_L .

Figure 3(A) illustrates a circuit just like Figure 2, except for one thing; a diode tube with an indirectly heated cathode has been added. One of the low voltage secondary windings is used to supply energy to the heater of this tube. The heater raises the cathode temperature to a point where the cathode is emitting electrons. Figure 3(B) shows the alternating-current voltage which appears across the high voltage secondary of the transformer at points A and B. This is exactly the same as that in Figure 2. However, unlike the circuit in Figure 2, current will not flow through the load resistor on all parts of the a-c cycle. Remember that a **vacuum-tube will only pass current** (or conduct) **when the plate is positive in respect to the cathode**. This was mentioned as the **Edison Effect** in a previous assignment. During the portion of the a-c cycle when point A is positive in respect to point B, current will flow through the vacuum-tube from the cathode to the plate. This current flow produces a voltage drop across the load resistor R_L as shown in (C) of Figure 3.

When the a-c voltage across the high voltage secondary is of the opposite polarity, that is, when point A is negative in respect to point B, **no** current will flow through the vacuum-tube circuit. If no current is flowing through the tube, there will be no voltage drop across the load resistor R_L . Since $E = IR$, when I is zero, E will also be zero. This is shown in Figure 3(C) also. In this figure, the portion of the wave from 1 to 2 is the voltage which will appear across R_L during the positive cycle of the a-c input to the circuit. During the negative alternation of the input wave to the circuit, no current flows and consequently no voltage appears across R_L . This is shown in the space between 2 and 3 in Figure 3(C).

During the next positive alternation of the input cycle, current again flows through the vacuum-tube circuit and through R_L , and the voltage across R_L will appear as shown between 3 and 4 in Figure 3(C). Notice that **current flows during only one half of the cycle**. This current flow occurs only on the half cycle when the plate of the vacuum-tube is positive in respect

to the cathode. During the other half of the input cycle, current does not flow through the load resistance; therefore, current flows only in the direction as shown by the arrow in Figure 3(A), and the voltage which appears across the load resistor R_L is a **pulsating direct-current voltage**. The polarity of the voltage across R_L is indicated in Figure 3(A).

A circuit such as illustrated in Figure 3 is called a **half-wave rectifier**. It is called **half wave** because the tube conducts on only half of the input wave. The negative portion of the input wave is lost. When alternating current is applied to the primary of the transformer, a current that flows in one direction is obtained in the load resistor of the secondary by placing the diode tube in series with this resistor. This current, in flowing through the load resistance, produces a pulsating d-c voltage. This voltage needs only smoothing out or **filtering** to be a d-c voltage similar to that produced by a battery.

Full-Wave Rectifiers

Figure 4 illustrates a transformer with two high voltage secondary windings. Indirectly heated cathode-type rectifier tubes are shown in the diagram. The heaters are not shown in this diagram; they are omitted to simplify the circuit. It will be assumed that a heater which is being supplied current from a low-voltage secondary winding is being used to heat the cathode of each tube. The two high-voltage secondary windings are so wound that when point 1 is more positive than point 2, point 3 will be more positive than point 4. The only difference in the circuits connected to the two high-voltage secondary windings is that while the plate of tube V_1 is connected to the top secondary at point 1, the plate of tube V_2 is connected to the bottom secondary at point 4.

When the primary of the power transformer is connected to the alternating-current supply, the two secondary windings will have equal a-c voltages built up across them. During the alternation of the a-c cycle when point 1 is positive, current will flow through the secondary circuit from point 2, through the load resistor from A to B, through vacuum tube V_1 from its cathode to its plate, and to point 1. The direction of this current flow is shown by the solid arrow in Figure 4. During the time the current is flowing in the top half of the secondary circuit, no current is flowing in the lower half of the secondary circuit. This is because the plate of the vacuum tube V_2 is connected to point 4, which will be negative while point 1 is positive. After the a-c voltage across the top secondary winding increases to its maximum value and returns to zero, point 1 will no longer be positive in respect to point 2, or in other words, the plate of vacuum tube V_1 is no longer positive in respect to its cathode, so current ceases to flow in the top secondary circuit.

As the a-c voltage builds up on the other alternation, point 1 becomes negative in respect to point 2, so current will not flow in the top secondary circuit. However, during this time, point 4 is positive in respect to point 3.

Since the plate of vacuum tube V_2 connects to point 4, current will flow in the lower secondary circuit during this half of the a-c input cycle. So while no voltage appears across AB during this half of the cycle, a voltage does appear across CD; while on the other half of the cycle, a voltage appears across AB and there is no voltage across CD. This is illustrated by the voltage diagram Figure 4(B). We see that the circuit actually consists of two half-wave rectifiers. One of these rectifier circuits is using one alternation of the a-c voltage while the other one is using the other alternation of the a-c voltage. Therefore, in this arrangement, neither alternation of the a-c voltage will be lost as in the half-wave rectifier described previously.

The polarity of the voltages across AB and CD is interesting. Notice, in the resistor between A and B, that when the current does flow, it will always flow **from A to B**. This is because the electron flow in the vacuum tube V_1 is from the cathode to the plate. In the resistor between C and D, the current will flow on the other half cycle **from C to D**. **Remember that, when current flows through a resistor, the end of the resistor which the electrons first encounter will be the negative end of that resistor.** Therefore, whenever there is a voltage across these two resistors, point A will be negative in respect to point B, and point C will be negative in respect to point D. So A and C are the negative ends, and B and D are the positive ends of these two resistors. There is a pulsating d-c voltage built up across each of these resistors.

Figure 5(A) is the same as Figure 4(A) with the exception that points A and C have been connected together and points B and D have been connected together. Points A and C are both negative and points B and D are both positive points. With this connection, the circuit will operate just as it did in Figure 4(A). On one half of the cycle, tube V_1 will conduct as shown by the arrow, and on the other half of the cycle, tube V_2 will conduct as shown by the dotted arrow. Figure 5(B) shows a more practical rectifier circuit. In this type circuit, there are not two separate high voltage secondary windings on the transformer, but instead there is a center-tapped high voltage secondary winding. We have numbered this 1, 2, 3, and 4 just as in Figures 4(A) and 5(A) for clarity. Notice that, in Figure 5(A), points 2 and 3 are connected together by the wire connecting point A and C. For this reason, it is cheaper to build a transformer with only one lead coming out from this connection such as is shown in Figure 5(B). It will also be noted in Figure 5(A), that resistors AB and CD are in parallel. Figure 5(B) shows only one resistor which is used in the place of the two resistors in the previous diagram.

The operation of the circuit in Figure 5(B) will be the same as that in Figure 4(A). While the top of the secondary (point 1) is positive with respect to the center tap, the bottom end of the secondary (point 4) will be negative in respect to the center tap. When the top of the secondary is positive in respect to the center tap, current will flow from the center tap,

through the load resistor to the cathode of V_1 , through V_1 from cathode to plate, and through the top half of the secondary back to the center tap. Current will continue to flow through this portion of the secondary winding as long as point 1 is positive in respect to the center tap. During this half cycle, point 4 is negative in respect to the center tap, so no current is flowing through the tube in the bottom half of the secondary winding. As the alternating voltage goes to the other alternation, point 4 becomes positive in respect to the center tap while point 1 becomes negative in respect to the center tap. Under these conditions, current will flow from the center tap through the resistor to the cathode of V_2 from the cathode of V_2 to the plate, and from the plate through the bottom half of the secondary back to the center tap. The direction of this current flow is indicated by the dotted arrow in Figure 5(B). Thus we see that, on one alternation, the voltage built up across the load resistance is due to the current flow in V_1 , while on the other alternation, it is due to the current in V_2 . However, the polarity of the voltage in each case is the same. Notice that the current flow through the resistor is always from left to right in Figure 5(A).

Figure 5(C) shows the wave shape of the voltage which is developed across the load resistor. Compare this to the voltage which is built up across the load resistor of the half-wave rectifier as shown in Figure 3(C). Notice that in the half-wave rectifier, only one half of the input wave was used while the other was discarded. In the full-wave rectifier, which is the circuit shown in Figure 5(B), both halves of the input wave are used. If the alternating current applied to the primary of the power transformer is a 60 hertz current, there will be 120 peaks per second in the output voltage. While the input is going through one cycle (going from zero to a positive peak, back to zero, to a negative peak and back to zero again), the voltage across the load is going to a positive peak, to zero, to another positive peak, and again to zero. The output voltage of this full-wave rectifier varies in amplitude, but it never reverses in polarity. If it were filtered to take out the amplitude variations, it would be a d-c voltage just as obtained from a battery.

In Figures 3, 4, and 5, we have shown rectifier circuits containing an actual load resistor or load resistors. In actual practice, the load for the rectifier circuit is not in the form of an actual resistor as shown in these diagrams, but is rather the transistor or vacuum-tube circuits of the electronics equipment. This is illustrated in Figure 6. Because the power supply is used to replace B batteries in electronics equipment, it is usually called the B supply. Its output is called the B voltage, the positive "end" of the power supply is called the B+, and the negative "end", is called the B-. The positive high voltage connection is taken off at the cathode of the rectifier tubes. The B- connection is taken off at the center-tap of the high-voltage secondary winding. The filter circuit is connected between the cathodes of the rectifier tubes and the load, which in this case is the plate circuits for the two vacuum-tubes. Remember, the purpose of this filter is to remove the pulsations from

the d-c voltage output of the rectifier, leaving pure d-c. We shall take this up in a short while.

To simplify the wiring job in vacuum-tube electronics equipment, it is also common practice to **ground** the B—. That is, the center-tap connection of the high voltage secondary winding is normally connected directly to the chassis. Then it is not necessary to run connections directly from the cathode circuits of the vacuum-tubes to the B— lead. This is illustrated in Figure 6(B). Notice that, in this figure, the center-tap of the high voltage secondary winding is connected directly to the chassis as are the cathodes on the tubes which form the load for this power supply. The current path in this circuit will be from the center-tap of the high voltage secondary winding, through the chassis to the cathodes of the tubes, through these tubes from cathode to plate, and through their load resistors to the B+. From the B+ the current then continues through the filter and through which ever tube is conducting at the moment, through its half of the secondary winding, and back to the center-tap of the secondary.

In all the rectifier circuits described previously, the rectifier tubes which were used employed indirectly heated type of cathodes. This type tube was used for the sake of simplicity in this assignment and it is used occasionally in electronics apparatus. However, the type circuit shown in Figure 6(C) is more commonly used. In Figure 6(C), a tube with a directly heated filament is used. The tube, shown in Figure 6(C), is a double-diode type tube; that is, it consists of two plates and one filament. The operation of this circuit will be identical with that of the other full-wave rectifier circuits shown. On one half of the cycle, current will flow from the center tap connection on the high voltage secondary winding to ground, and through the chassis connection to the B—. From the B— it will flow through the load and the filter to the filament connection of the rectifier tube. If the polarity of the applied alternating voltage across the high voltage secondary winding is such that the top end of the secondary winding is positive, current will flow from the filament of the rectifier tube to the top plate, through the top half of the secondary winding back to the center tap. On the other half of the cycle, the current flow will be from the filament through the vacuum tube to the bottom plate on the rectifier tube, then through the bottom secondary winding to the center tap.

Let us emphasize one point. The B+ connection from the power supply is taken off at the **filament** connection of the rectifier tube. This is the reason for separate windings on the secondary of power transformers for the rectifier tubes and for the other tubes in the electronics equipment as shown in Figure 2(A). If the same windings were used for the rectifier filament and the other filaments of the vacuum tubes, the positive high voltage would also be applied to the filaments of the other tubes in the electronics equipment. If a rectifier tube which uses an indirectly-heated cathode is employed, then it is permissible to use the same secondary winding for heating the filaments

of the rectifier tube and the other tubes in the equipment. The use of this type of tube results in a saving in the transformer cost. Examples of full-wave rectifier tubes, which have indirectly heated cathodes, are the 6X5, 12X4, and 7Z4 tubes. These tubes have heaters which were normally operated in parallel with the other heaters in the electronics equipment. However, most power supplies employing rectifier tubes use a directly-heated cathode such as shown in Figure 6(C). Examples of these are the type 5U4, 5W4, 5Z3, 5Y4, 80, etc. When these tubes are used, the power transformer always has two filament windings. One of these, the 5 volt winding, is used for the filament of the rectifier tube and the other one, normally the 6.3 volt winding, is used for the heaters or filaments of the other tubes in the equipment.

In most electronics circuits, a full-wave rectifier circuit such as shown in Figure 6(C) is used. In certain cases, however, it is desirable to use the half-wave rectifier. Half-wave rectification is used extensively in X-ray equipment, oscilloscopes and television receivers, where a very high voltage at low current is required. Advantages, disadvantages, and comparisons of these two systems will be discussed later in this assignment.

Filtering

If the d-c voltage developed by the rectifier is to be of any use, it must be **filtered**; that is, it must be "smoothed out" so that it is constant. The "dips" have to be filled in, so that the pulsating d-c becomes an almost pure d-c. The variations in amplitude of the pulsating d-c is called the **ripple**. The purpose of the filter then is to remove the ripple. Filters consist of capacitors, coils, and resistors.

Let us review briefly the action of the capacitor. If the d-c voltage is applied to a capacitor, it charges to the full voltage applied. If the capacitor is connected to a battery for example, it will charge to the voltage of the battery. If disconnected, it will hold the charge for a considerable length of time. When a resistor is placed across the charged capacitor, it will take a definite time for the capacitor to discharge through the resistor. Let us repeat this statement for emphasis. **If a resistor is connected across a charged capacitor, it will take a definite time for the capacitor to discharge through the resistor.**

Figure 7 shows a circuit similar to Figure 3(A), except that it has a capacitor connected across the load resistor. Figure 3(C) shows how the voltage across the load resistor varies without the capacitor in the circuit. Let us assume that in Figure 3(C), the voltage rises to a peak of +300 volts. In this figure then [Figure 3(C)], if the input is 60 hertz a-c, the voltage rises from zero to 300 volts and decreases again to zero in 1/120th of a second. This is shown in the time interval on the graph from 1 to 2. During the next 1/120th of a second, from 2 to 3 on the graph in Figure 3(C), the voltage remains at zero. During the next 1/120th of a second, from 3 to 4 on the graph, the voltage again rises to +300 volts and falls to zero again.

Without the addition of the capacitor from A to B, the circuit in Figure 7 would produce an identical wave shape in the output to that obtained in Figure 3(C). However, with a capacitor connected across the load resistor from A to B as shown in Figure 7, the wave shape of the output voltage will be considerably different. The wave shape is shown in Figure 8.

The dotted curve, shown between 1 and 2 and between 3 and 4 on the graph in Figure 8, is a curve similar to that of Figure 3(C), and illustrates the voltage which would be produced without the capacitor. The heavy line in this graph illustrates the voltage output with the capacitor connected. As the voltage builds up from zero to 300 volts on the first pulse of voltage, the capacitor will become charged to the full 300 volts. If a large enough value of capacitor is used, it will take a longer period than $1/120$ th of a second for it to discharge through the load. Notice that as the rectifier output voltage dropped below the 300 volts to which the capacitor is charged, the capacitor will then start to discharge through the load resistor. Since it takes a definite time for this to occur, the capacitor will not be completely discharged at point 3 on the graph. Therefore the voltage will not fall to zero as it did in Figure 3(C), but will follow a line similar to that shown in Figure 8.

Let us go over this action step by step. As the voltage across the load resistor rises to a peak value of 300 volts, the capacitor charges to 300 volts. This is illustrated at point A on the graph of Figure 8. As the voltage tries to decrease, as shown by the dotted line, the capacitor will discharge through the load resistor at a slower rate, as indicated by the heavy line from A to B. At point B on the graph, the rectifier voltage is again increasing and reaches the value of the capacitor, 200 volts in this case. The capacitor will then again charge from B to C on the graph, and at C will be charged to 300 volts. From C to D, it will again discharge through the load resistor and will be charged again during the period from D to E on the graph. Notice that the ripple is considerably less in this circuit than that in Figure 3(C). In other words the amount of amplitude change of the output voltage is less in this case. This illustrates that a capacitor across the load resistor will aid in filtering the output voltage from the rectifier. Notice that the current through the rectifier flows only during the time the capacitor is charging—time B-C, D-E, etc., in Figure 8.

The above discussion illustrated the effect of a capacitor in filtering the pulsating d-c, considering the fact that a certain amount of time is required to discharge a capacitor. The filtering action of a capacitor can also be visualized by first breaking the pulsating d-c into two components (a-c and d-c), and applying the fact that a capacitor will **effectively** pass a-c.

Figure 9 illustrates the fact that the output of a rectifier is composed of two components, a d-c component and an a-c component. Figure 9(A) shows a d-c voltage impressed across a resistor. The graph of this voltage is to the right of the circuit diagram. The graph of the d-c voltage is a straight line

since it does not change with time, but remains 100 volts. Figure 9(B) illustrates an alternator with a peak voltage of 10 volts. The voltage varies from +10 to -10 volts. The graph of this voltage is shown at the right of the circuit diagram. Figure 9(C) shows both the battery and the alternator connected in series with the resistor. The voltage across the resistor will vary from +90 volts (when the alternator voltage is -10) to 110 volts (when the alternator voltage is +10). This voltage illustrated in Figure 9(C) is a pulsating d-c voltage, but is shown to be composed of two components—a d-c voltage as shown in Figure 9(A) and an a-c voltage as shown in Figure 9(B). Similarly, Figure 9(F) shows that a rectifier output is composed of two voltages—a d-c voltage and an a-c voltage (ripple). The d-c voltage is shown in Figure 9(D), and the a-c voltage (ripple) is shown in Figure 9(E). When these two are combined, the output voltage is as illustrated in Figure 9(F). Figure 9(I) illustrates the same effect with less a-c voltage applied. In this case, the d-c component as shown in Figure 9(G) is 100 volts but the a-c component, as shown in Figure 9(H), reaches a peak of only 10 volts. The combination of these two as shown in Figure 9(I) has a smaller ripple component, which also tells us that it has a smaller a-c component.

In previous assignments it was shown that capacitors offer low impedance to an alternating current and a very high impedance to a direct current. In other words, the effect of a capacitor is to pass an alternating current and to **stop** a direct current. Thus the effect of the filter capacitor in Figure 7 may be considered to be that of “by-passing” the a-c component around the load resistor, but offering a high resistance to the passage of the d-c component. Thus, the d-c component will flow through the load resistor, whereas the a-c component will be by-passed around the load resistor. Remember, however, that this explanation of the action of a filter capacitor is explaining exactly the same thing as was shown in Figure 8.

While a filter capacitor will aid in filtering or smoothing out the ripple from a rectifier, the amount of ripple remaining in Figure 8 is still too great to be used in ordinary electronics equipment. For this reason, “filter chokes” are often used in the filter circuits of rectifiers in addition to capacitors.

Before considering the filter circuit consisting of a choke and a capacitor, let us review the action of a choke.

A filter choke is merely a coil of wire with a great number of turns, which has an iron core to increase its inductance. The inductance of a filter choke is usually several henries. In the discussion of coils (chokes) in previous assignments, we learned that one property of a choke is to oppose **any change** in the amount of current flowing through the choke. That is, if the current flowing through a choke tends to increase, the choke will oppose this increase in current, or if the current tries to decrease, the choke will oppose the decrease in current.

Figure 10 illustrates a half-wave rectifier circuit whose filter consists

of a choke and capacitor. The choke is connected in series between the cathode of the rectifier tube and the load resistor. As rectified current flows in the circuit, lines of magnetic flux build up in the choke coil. When the current starts to decrease, the magnetic field around the choke coil collapses and cuts the conductors of the choke. This produces a counter voltage, which tends to cause a flow of current at the former rate. The result is that the output voltage does not rise to as high a value as illustrated in Figure 8, nor does it fall as much. For example, instead of rising to 300 volts and falling to 200 volts as illustrated in Figure 8, it would vary from possibly 270 volts to 250 volts, as a result of the addition of the choke. The **inertia effect** of the choke acts to keep the output relatively constant.

Another advantage of the choke is that it lengthens the period during which the current flows through the rectifier (B-C, D-E in Figure 8). This **reduces the peak current** flowing through the rectifier, thereby prolonging the life of the rectifier.

Let us consider the action of a filter choke from the viewpoint of the output voltage of the rectifier being composed of two components—an a-c component and a d-c component. The choke has a relatively low d-c resistance, typical chokes ranging from a few ohms to a few hundred ohms resistance. The current the power supply must furnish determines the size wire with which the choke will be wound. Hence, the wire size and length will determine the d-c resistance of the choke. The length of the wire will be based on the number of turns necessary to give the required inductance for the choke in the circuit. However, the **reactance** of the choke is high. Remember the reactance of a choke coil determines the amount of opposition it offers to the flow of **a-c current**. As an example, a 10 henry choke would have a reactance of 3,768 ohms if the frequency were 60 hertz ($X_L = 2\pi fL = 6.28 \times 60 \times 10 = 3,768$ ohms).

Let us now analyze the circuit shown in Figure 10. In view of the two components present in the rectified output, that is, the a-c component and the d-c component, the way this circuit "looks and acts" to these two components is illustrated in Figure 11. Figure 11(A) illustrates the way the filter circuits act as far as the a-c component is concerned. We have selected values for the choke and the capacitor so that the reactance of the choke at the 60 hertz frequency is 4000 ohms, and the reactance of the capacitor is 200 ohms. Since the choke and the capacitor are in series as far as the a-c component is concerned, **the a-c voltage appearing across these components will be proportional to the reactance**. In this case, the reactance of the choke is 20 times as great as that of the capacitor; therefore, the a-c voltage drop across the choke will be 20 times as great as that across the capacitor. Remember that the load is connected in parallel with this capacitor, so only the portion of the ripple voltage appearing across the capacitor will be appearing across the load. In this case, only 1/21 of the ripple output from the rectifier tube would appear across the load. Thus, we see that the ripple output of the

voltage applied to the load is small compared to the ripple output from the actual rectifier tube.

Figure 11(B) illustrates the d-c circuit. The capacitor is an open circuit as far as d-c is concerned and may be neglected in considering the d-c circuit. R_c is the **resistance** of the choke, not the reactance. Since, as far as direct current is concerned, the resistance of the choke and the load resistance are connected in series, the same current flows through each; and the voltage drop across each is proportional to the resistance. Since the resistance of the load in Figure 11(B) is 99 times as large as the **resistance** of the choke, there will be 99 times as great a d-c voltage drop across the resistance of the load as the d-c voltage drop across the resistance of the choke (R_c). Thus, we see that this filter delivers 99 per cent of the d-c component to the load resistor and only about 1/21 of the a-c or ripple voltage. Thus, we see it is effective as a filter because it allows only a small percentage of the a-c ripple voltage from the rectifier to appear in the output. This particular filtering arrangement is called a **choke-input single-section filter**. A choke and a capacitor in a filter are considered to be **one section**. It is called a choke-input filter due to the fact that the choke is connected between the filter capacitor and the rectifier.

Figure 12(A) shows a single-section choke-input filter. It is the same filter shown in Figure 10, but is drawn differently to illustrate the voltage dividing effect of the filter on the ripple. If the values of the capacitor and choke in these filter circuits of Figure 12 are the same as those of Figure 11(A), the circuit of Figure 12(A) will reduce the ripple to about 1/20 of the input ripple. Only 1/20 of the input ripple will appear across the load resistor R_L , while almost all of the d-c voltage is across this load resistor. The circuit of Figure 12(B) is a two-section choke-input filter. The first section has reduced the ripple to 1/20 of its original value. The second section, like the first, will reduce the ripple by 1/20; so the ripple voltage across the load resistor will be only 1/20 of 1/20, or 1/400 of the original input ripple voltage. The circuit in Figure 12(C) is a three-section choke-input filter. This will further reduce the ripple by 1/20, so the output of this section will be 1/20 of 1/400 or 1/8000 of the original ripple. The d-c voltage across the load resistor in this case will be the d-c component of the input to the filter minus the d-c voltage drop across the resistance of the three chokes. Thus, we see that the filtering process can be carried out to almost any desired point.

Figure 13 illustrates these three filter circuits the way they would normally be drawn. All are choke-input filters. At (A) is shown a single-section filter, (B) a double-section filter or two-section filter, and (C) a three-section filter. Graphs of the output voltage from these three types of filters are shown also. Notice that the graph shown in 13(B) illustrates that the output voltage from this filter more nearly approaches a pure d-c voltage than that of the single-section filter shown in 13(A). Likewise, the output from the three-section filter shown in Figure 13(C) very closely approaches the voltage output from a battery and is superior to that of Figure 13(B).

Another type of filter, which is often used, is the capacitor-input type of filter. Figure 14 illustrates three types of capacitor-input filters. Of these three filters the one shown in 14(A) is used most often. This circuit is generally referred to as a **pi-type** filter. It is so called due to the fact that, when it is drawn as shown in Figure 14(A), it resembles the Greek letter π . A capacitor-input filter has one advantage and one disadvantage when compared to a choke-input filter. The advantage of a capacitor-input filter over a choke-input filter is that, with normal loads, higher output voltages are available with the same amount of filtering when using a power transformer with the same voltage rating. Thus, if a given transformer produced an output of 300 volts d-c with a choke-input filter (with a light load) it might produce as much as 400 volts d-c output with a capacitor-input filter. The disadvantage of a capacitor-input filter, when compared to a choke-input filter, is that the output voltage changes considerably with the changes in the load. This is called **poor regulation**. Regulation is measured in percentage and may be calculated by the following formula:

$$\text{Percent of regulation} = \frac{E_{\text{no load}} - E_{\text{full load}}}{E_{\text{full load}}} \times 100.$$

As an example, if a power supply furnishes 125 volts at no load, and at full load the output voltage is 100 volts, the regulation could be found by applying the formula:

$$\text{Percent of regulation} = \frac{E_{\text{no load}} - E_{\text{full load}}}{E_{\text{full load}}} \times 100$$

$$\text{Percent of regulation} = \frac{125 - 100}{100} \times 100 = \frac{25}{100} \times 100 = 25 \text{ percent.}$$

This would be considered rather poor regulation. The smaller the percentage of regulation, the better the power supply is considered to be. In capacitor-input filters, the percentage of regulation will be high (poor regulation) which is undesirable, but the voltage output will be high which is desirable in many cases. Poor regulation is undesirable because the change in the amount of current drawn by the load will cause a change in the voltage applied to the apparatus which is being operated from the power supply. This may cause the equipment to function improperly.

The single-section capacitor-input filter, or the pi filter as it is often called, is designed to use large values of inductance and capacitance as compared to those used in choke-input filters. In power supplies for electronics equipment employing vacuum-tubes, typical values are from 10 to 30 henries for the choke and from 8 to 40 microfarads for the capacitors.

With a light value of load, the voltage output of the capacitor-input filters may be as high as 1.4 times the rms value of the a-c voltage applied to the rectifier. If a half-wave rectifier is used, the output may be 1.4 times the entire secondary voltage; and in a full-wave rectifier, the output voltage

may be 1.4 times $\frac{1}{2}$ of the secondary voltage. However, with heavy values of load current, the output voltage may drop to a value which is less than the rms value of the a-c applied voltage.

A choke-input type of filter will have a voltage output of about .9 of the rms value of the applied a-c voltage, but it will have good regulation and will change little under load. Graphs illustrating the regulation of these two types of filters may be seen in your vacuum tube manual under the 5Y3GT type of tube. Look up this tube in your tube manual and compare the two families of curves which are given. Notice that with the choke-input type of filter, with 500 volts applied to each plate of the rectifier tube, the output voltage will range from approximately 440 volts with a load of 10 milliamperes to 380 volts with a load of 120 milliamperes. This represents a voltage drop of approximately 60 volts over the range of current. Now, notice the curve for the capacitor-input filter. With this type filter, with a load of 10 milliamperes, more output voltage (in this case 460 volts) can be obtained with only 350 volts rms applied to each plate of the rectifier tube. However, it will be noted that, with an increase in current to 120 milliamperes, the output voltage of the capacitor-input type filter falls to approximately 350 volts. Thus, we see that the capacitor-input filter has much poorer regulation than the choke-input filter since its voltage change was 110 volts over the same current range as that of the choke-input filter. For comparison, let us compute the percentage of regulation of the two filters, using the values shown in the curves for the 5Y3 tube. For the choke-input filter:

$$\begin{aligned}
 \text{Percentage of regulation} &= \frac{E_{\text{no load}} - E_{\text{full load}}}{E_{\text{full load}}} \times 100 \\
 &= \frac{440 - 380}{380} \times 100 \\
 &= \frac{60}{380} \times 100 \\
 &= .158 \times 100 \\
 &= 15.8 \text{ percent.}
 \end{aligned}$$

For the capacitor-input filter:

$$\begin{aligned}
 \text{Percentage of regulation} &= \frac{E_{\text{no load}} - E_{\text{full load}}}{E_{\text{full load}}} \times 100 \\
 &= \frac{460 - 350}{350} \times 100 \\
 &= \frac{110}{350} \times 100 \\
 &= .314 \times 100 \\
 &= 31.4 \text{ percent.}
 \end{aligned}$$

Thus, we see that the regulation from the choke-input filter is much better than that from the capacitor-input filter. Study these curves carefully until these two facts become clear in your mind: (1) Under light loads much higher voltages can be obtained from the capacitor-input filter and (2) with a varying load much better regulation can be obtained from the choke-input filter.

When considering the input capacitor rating of a capacitor-input filter, it is always well to remember that it must have a peak voltage rating of 1.4 times the rms a-c voltage to the rectifier. This is because the input capacitor will charge up to the peak value of the rectified voltage as illustrated in Figure 8. You will recall from a-c theory that the peak value of the a-c voltage is approximately 1.4 times the rms value. If a capacitor, which is chosen for this service, does not have a high enough voltage breakdown rating, the dielectric of the capacitor will be subject to a greater stress than that for which it was designed to withstand and it will "breakdown". The other capacitors in the filter network may have voltage ratings closer to the actual d-c output voltage of the filter.

Bleeder Resistors

In addition to the power transformer, rectifier, filter chokes, and capacitors, many power supplies contain another component called the **bleeder resistor**. Bleeder resistors are connected directly across the output terminals of a power supply from the B+ to the B—. Bleeder resistors serve two purposes. A bleeder resistor will improve the regulation of a power supply because the power supply is never operating at a completely "no load" condition. Since the bleeder is connected directly across the output of the power supply, the current drawn by the bleeder resistor will be a load on the power supply, even if the other load, such as vacuum tubes as was illustrated in Figure 6(A), is drawing no current. The bleeder is also a safety device. It has been pointed out several times in this assignment and in previous assignments, that if a capacitor is charged and then disconnected from the source of voltage, the capacitor will hold this charge for a considerable length of time. If a bleeder is not used, the filter capacitors in the power supply may hold their charge for several hours if the load is disconnected from the power supply. **Technicians have been killed by contact with power supply filter capacitors, particularly those in transmitters.** If a bleeder resistor is connected across the output of the power supply, the charged capacitors will discharge through the bleeder resistor, in case the load is disconnected. The bleeder resistor is usually selected which will carry about one tenth of the rated current which the power supply is designed to deliver. In many installations, the bleeder also serves as a voltage divider, distributing the proper voltages for the operation of the various circuits in the electronics equipment.

Let us see how a voltage divider works. Ohm's Law states that the

voltage across any resistor is equal to the current through the resistor times the resistance of the resistor. Or to state it mathematically, $E = IR$.

In Figure 15, three resistors (R_1 , R_2 , and R_3) are connected in series, and 80 volts is applied across the series combination. To find the equivalent resistance of these three resistors in series, we apply the formula:

$$\begin{aligned}R_T &= R_1 + R_2 + R_3 \\ &= 20 + 15 + 5 \\ &= 40 \text{ ohms.}\end{aligned}$$

Since these resistors are in series, the same current will flow through each. To find the current flowing through the resistors, we apply Ohm's Law:

$$\begin{aligned}I &= \frac{E}{R} \\ &= \frac{80}{40} \\ &= 2 \text{ amperes.}\end{aligned}$$

Thus, we find that there are 2 amperes of current flowing in each resistor.

The voltage drop across **each resistor** will be equal to the current through **that resistor** times the resistance of **that resistor**. Accordingly, the voltage drop across R_1 will be:

$$\begin{aligned}E &= IR \\ &= 2 \times 20 \\ &= 40 \text{ volts.}\end{aligned}$$

In a similar manner we can find the voltage across R_2 to be 30 volts and the voltage drop across R_3 to be 10 volts. This is indicated in Figure 15 and the polarity of these individual voltage drops is shown. If Figure 15 is examined, it can be easily determined that point A is 10 volts positive in respect to point X, point B is 40 volts positive in respect to point X, and point C is 80 volts positive in respect to point X. Thus, we see that by connecting resistors in series, the total voltage of 80 volts has been divided into steps of 10 volts, 40 volts, and of course, the total of 80 volts. The resistor network then is a **voltage divider** network.

We may determine the power dissipated in each resistor by applying the formula: $P = I^2R$.

$$\begin{array}{lll}\text{Power in } R_1 & \text{Power in } R_2 & \text{Power in } R_3 \\ P = I^2R = 2^2 \times 20 & P = I^2R = 2^2 \times 15 & P = I^2R = 2^2 \times 5 \\ = 4 \times 20 = 80 \text{ watts} & = 4 \times 15 = 60 \text{ watts} & = 4 \times 5 = 20 \text{ watts}\end{array}$$

The wattage dissipation is an important factor in the design of a voltage divider. Power varies as the square of the current (I^2R), therefore those

sections of the voltage divider which carry high current must be capable of handling considerable power. It must be able to dissipate the power which appears as heat. If for example, a 1 watt resistor were used for R_1 in the circuit in Figure 15, the resistor would become very hot and burn out. The 1 watt resistor is quite small and cannot radiate the heat produced by 80 watts of power. In this case, a resistor of at least 80 watts should be used for R_1 . The 80 watt resistor would be much larger in size than the 1 watt resistor. This allows it to radiate a great deal more heat without too great a temperature rise.

Figure 16 shows the circuit diagram of a full-wave rectifier with a two-section choke-input filter. A d-c voltage of 300 volts is applied across the bleeder resistor from the filter. The bleeder consists of two resistors in series. Each has a value of 5000 ohms, so the total bleeder resistance is 10,000 ohms and the bleeder current which will flow is 30 milliamperes. There are three wires coming from the bleeder (A, B, and C). The difference in potential (or voltage drop) from C to A is 300 volts; from C to B, it is 150 volts. This condition is true only with no load connected to the power supply. Suppose, however, that the plate circuits of several vacuum tubes are to be supplied by the voltage from A to C, as shown in Figure 6(A). This will furnish current to the vacuum tubes, and the only effect on the voltage across the bleeder resistor will be a small decrease of voltage due to an increased voltage drop across the filter chokes. (Remember, the filter chokes have some d-c resistance, and as the current through them increases, the voltage drop across them will increase.) The voltage between B and C remains one-half of the voltage between A and C. Since the voltage drop across the entire bleeder resistor is less than with no load, less current will flow through the bleeder. However, the bleeder resistor should have a power rating capable of dissipating the power under no load conditions.

Suppose the load is connected across the leads B and C. Without a load the voltage at B in volts is 150 volts positive in respect to point C; with a load however it will be less. If the resistance of the load is, for example, 5000 ohms and is placed across the leads B and C, it is in parallel with the bottom bleeder resistor. The two resistors in parallel will have a resistance of 2500 ohms. The total resistance will be 7500 ohms, and the total current will be 300 divided by 7500 or 40 milliamperes. Since the load and the bottom bleeder resistor are equal in value, the current will divide equally and 20 milliamperes will flow through each of them. The bleeder resistor connected between points A and B will carry the full 40 milliamperes of current. The voltage drop across this resistor will be:

$$\begin{aligned} E &= IR \\ &= .04 \times 5000 \\ &= 200 \text{ volts.} \end{aligned}$$

So the voltage across the leads B and C will not be 150 volts as with no load, but will be 100 volts. This can be found by subtracting the 200 volt

drop across the resistor between A and B from the 300 volts of the supply. This **entire explanation has been given to show that the voltage on any point of a voltage divider is determined not only by the bleeder current, but by the combined bleeder current and the currents of the external loads.**

In the practical design of a voltage divider, the currents and voltages are known, and the resistors are calculated which will give these currents and voltages. Figure 17 is a voltage divider system that can be used across a 300 volt rectified and filtered d-c voltage. It is designed to supply all the current a particular piece of electronics equipment needs and still allow a bleeder current of 10 milliamperes. The following voltages are needed in this case: 75 volts at 2 milliamperes for one tube, 100 volts at 5 milliamperes for the screen grids of the various tubes, and 250 volts at 20 milliamperes for the plate circuits of the tubes. All of this information could be obtained from a tube manual.

The first step in figuring the resistance of the various voltage divider sections, in such a circuit, is to draw a schematic diagram of the circuit such as shown in Figure 17. Study the circuit in Figure 17 carefully. The various current paths are indicated by the arrows in this diagram. It was stated that the bleeder current was 10 milliamperes, and this is shown in the diagram. In addition to this bleeder current, we have 2 milliamperes of current flowing through the load which requires 75 volts, 5 milliamperes through the load which requires 100 volts, and 20 milliamperes through the load which requires 250 volts. The circuit is sketched, and the currents flowing through each section are labelled as shown in Figure 17. Through the section labelled R_1 the only current which flows is the bleeder current which was given as 10 milliamperes. Notice that this current flows from the negative side of the supply through this resistor, through R_2 , R_3 , and R_4 , and back to the positive side of the supply. The 2 milliamperes which are drawn by the 75 volt load do not flow through R_1 but do flow through R_2 , R_3 , and R_4 . The 5 milliamperes load of the 100 volt load does not flow through R_1 and R_2 , but flows from the negative side of the supply, through the load, through R_3 and R_4 , and back to the positive side of the supply. In a like manner, the 20 milliamperes of the 250 volt load do not flow through R_1 , R_2 , and R_3 , but flow through R_4 . Thus, we see that the total current through R_1 is 10 milliamperes, through R_2 is 10 milliamperes of bleeder current plus 2 milliamperes of the 75 volt load or 12 milliamperes. The current through R_3 is the 10 milliamperes of bleeder current, plus the 2 milliamperes of the 75 volt load, plus the 5 milliamperes of the 100 volt load, or a total of 17 milliamperes. In a similar manner, we find the current through R_4 to be 10 plus 2 plus 5 plus 20 milliamperes, or 37 milliamperes. Figure 17 also shows the desired voltage drop across each section of the voltage divider. A 75 volt drop is required across R_1 , R_2 requires a 25 volt drop so that point (A) will be 100 volts positive in respect to the negative side of the supply ($75 + 25 = 100$). The voltage drop across R_3 will be 150 volts, so that point (B) will be 250 volts positive in respect to the negative side of the

supply (75 + 25 + 150 = 250 volts). There will be a 50 volt drop required across R_4 since the power supply delivers 300 volts and point B is only 250 volts positive in respect to ground. Since we know the current through each section of this voltage divider and the voltage drop required across each section, we can apply Ohm's Law to determine the required resistance of each section.

$$R_1 = \frac{E}{I}$$

$$R_1 = \frac{75}{.01}$$

$$R_1 = 7500 \text{ ohms.}$$

$$R_2 = \frac{E}{I}$$

$$R_2 = \frac{25}{.012}$$

$$R_2 = 2083 \text{ ohms.}$$

$$R_3 = \frac{E}{I}$$

$$R_3 = \frac{150}{.017}$$

$$R_3 = 8824 \text{ ohms.}$$

$$R_4 = \frac{E}{I}$$

$$R_4 = \frac{50}{.037}$$

$$R_4 = 1351 \text{ ohms.}$$

Thus, we have calculated the resistance necessary for the individual sections of this voltage divider. To find the total resistance of the voltage divider, we may add these four sections. The total resistance would be found to be 19,758 ohms.

A 20,000 ohm 50 watt resistor, with three sliding taps, would ordinarily be used for this voltage divider because of the difficulty of obtaining the odd values of resistors listed above. With a sliding-contact single-resistor voltage divider, it is possible to compensate for small errors in calculations. The easiest method for setting the taps is to approximate the positions for the different taps by using an ohmmeter with the bleeder disconnected, then connect the equipment, and make final adjustments of the taps while taking

measurements with a voltmeter. Care should be exercised in handling such equipment when the power is on. If possible, all such adjustments should be made while the power is off. As an extra precaution, the filter capacitor should be short circuited with a piece of wire before working on the unit. This is particularly true when transmitter power supplies, which are capable of delivering quite high voltages, are being adjusted.

Figure 18 shows a diagram of a typical power supply with a graph of the voltages at different points shown. The input of the transformer is a 60 hertz alternating voltage. The transformer "steps up" the voltage to the desired value and applies it to the rectifier tube. The output of the rectifier is a pulsating direct current with 120 hertz ripple. (This rectifier circuit is a full-wave rectifier and the ripple frequency is twice the line frequency.) The input to the second section of the filter is similar, but the ripple voltage is much less. The input to the voltage divider section is practically pure d-c. The taps give various d-c voltages as represented by the last graph.

Comparison of Full-Wave and Half-Wave Rectifiers

We have seen that there are two general methods used for rectification of 110 volts 60 hertz current; half-wave rectification and full-wave rectification. Let us see under what conditions each of these types would be used. In a great majority of electronics equipment the full-wave rectifier output is much easier to filter than that from the half-wave rectifier. If the pulsating d-c output from the half-wave rectifier [as shown in Figure 3(C)] is compared to that of the full-wave rectifier [as shown in Figure 5(C)], it will be noted that in a given period of time only one half as many pulses occur for the half-wave rectifier as for the full-wave rectifier. Or to state this in a different manner, the ripple frequency of the half-wave rectifier is the same as the line frequency (60 hertz in most cases), whereas the ripple frequency in the full-wave rectifier is twice that of the line frequency or 120 hertz.

If we look at the filtering problem of these two pulsating voltages from the viewpoint of the time required for discharging the capacitor and the time required for the magnetic field of the choke coil to collapse, it is easy to see that it would be easier to filter the full-wave rectifier voltage than it would the half-wave rectifier output voltage. This is obvious, since in the half-wave output there is a considerable space wherein there is no voltage output and the capacitor voltage or choke counter emf can fall to a low value during this period.

If we look at this same problem from the viewpoint of the reactance of the choke and capacitor as in Figure 11(A), we can get another picture of the reason for using the full-wave rectifier in most cases. It will be recalled that the reactance of a choke is $X_L = 2\pi fL$. The f in this case is the ripple frequency. Thus, we see that, for a given line frequency input

(60 hertz in most cases), the ripple frequency from the full-wave rectifier is twice as high as that of the half-wave rectifier; and therefore the reactance of a given choke would be twice as high for the full-wave rectifier. Thus, we see that the choke would be more effective in filtering. Likewise, the reactance of a capacitor is inversely proportional to the frequency, or

$$X_C = \frac{1}{2\pi f C}$$

Thus, the reactance of the capacitor decreases due to the

increased frequency of the full-wave rectifier and the filtering process is further improved. To emphasize this point, if the same values of inductance and capacitance as are used in Figure 11(A), are used in a full-wave rectifier circuit, the X_L of the choke will be 8000 ohms, and the X_C of the capacitor will be 100 ohms. Thus, we see that the ripple voltage which appears across the capacitor will be only 1/81 of the entire ripple output voltage from the rectifier. When this is compared to the 1/21 which is obtained from these same values of inductance and capacitance in the half-wave rectifier, we see that the filtering process for a full-wave rectifier is almost four times as easy to produce. This is the main reason for using full-wave rectification in most electronics equipment. In another assignment, we shall see applications where half-wave rectification is used quite often. This is usually done for economy and not for quality.

Half-wave rectification is sometimes used when it is desired to obtain as high an output voltage as possible from a given transformer. This is particularly true when low-current high-voltage power supplies are being considered. This is illustrated in Figure 19. In Figure 19(A), we see a power transformer with a high voltage secondary which has 1000 volts rms across the entire winding. The wave shape of the pulsating d-c from the rectifier is shown also in this figure. It will be noted that the output voltage reaches a peak of approximately 1400 volts. This is due to the fact that the 1000 volts as indicated across the secondary is the rms value of a-c voltage. To find the peak value of a-c we multiply the rms value by 1.414. This gives us a peak value of approximately 1400 volts, which is appearing across the entire high voltage secondary winding. When this is rectified approximately 1400 volts will be produced across the rectifier output. As we might expect, the rectifier tube is not a perfect conductor. It has some resistance and consequently there will be some voltage drop across it when current is flowing.

Let us contrast this with the full-wave rectifier circuit shown in Figure 19(B). This transformer also has an rms value of 1000 volts across the entire secondary winding. However, this secondary winding is center tapped and one half of this voltage, 500 volts rms, is applied to one plate of the rectifier tube and the other half of the voltage, or 500 volts, is applied to the other plate of the rectifier tube. At the right of this diagram, we see a graph of the voltage output from this rectifier. It will be noticed that the peak value

of the output voltage from this rectifier circuit is only 700 volts. This is because actually only one half of the rectifier is working at one time. This was illustrated in Figure 5(A) where it was shown that the full-wave rectifier actually consists of two half-wave rectifiers connected to the same load. The actual voltage applied to each half-wave rectifier is only 500 volts rms. For this reason, it can be seen that a higher output voltage can be obtained from a given transformer secondary winding by using a half-wave rectifier circuit. Since it is comparatively easy to filter a high-voltage low-current output the half-wave circuit as shown in Figure 19(A) is often used for this application. Typical examples of this are the high-voltage power supply in the cathode-ray oscilloscope and the power supply used to generate the high voltages used by the picture tube in television receivers or radar monitors. However, most industrial electronics equipment employs the full-wave rectifier circuit as shown in Figure 19(B).

In high-voltage, very low current power supplies, such as those used in cathode-ray oscilloscopes, television receivers, and radar monitors, the current drain is **very low**. Often it is in the order of a few microamperes. For this reason, it is possible to eliminate the filter choke which is a fairly expensive component, and replace it with a resistor. Such a filter network is shown in Figure 20. Since the current drawn by the load is very small, the d-c drop across the filter resistor will be small, yet this filter will do an effective job of removing the ripple from the rectifier output. If you will look at Figure 14(A), you will observe that the resistor offers opposition to the a-c component in the π type filter similar to that offered by the choke. Such a filter circuit is used almost exclusively in these high voltage, low current supplies.

Summary

In this assignment, we have covered the basic principles of rectification. We have studied in detail the operation of a half-wave rectifier and a full-wave rectifier circuit. We have also seen the need for filtering and have discussed a number of methods of obtaining filtering. In addition to this, we have found how to compute the value of resistance necessary for voltage divider use.

You should copy the schematic diagrams of the basic types of power supplies, and study them, until you can readily reproduce them from memory. Figure 20 shows a half-wave rectifier circuit and π type capacitor-input filter. This is a good example of this type circuit to learn. For a full-wave rectifier and choke-input two-section filter circuit, the diagram shown in Figure 18 is excellent. You are urged to draw these several times, until you can draw the complete circuits from memory. These power supply circuits will appear frequently throughout the training program and a large majority of the electronics equipment in service today uses them.

These basic rectifier principles are used in a number of special type of

rectifier circuits. For example, the universal a-c d-c rectifier circuit, bridge rectifier circuits, rectifier circuits for use with auto radios, etc. These special types of circuits will be taken up in a future assignment. However, it should be emphasized, that the basic principles outlined in this assignment will be used for the complete understanding of these specialized power supply circuits in the future assignments. For this reason, do not pass on from this assignment to the next until you are sure that you understand completely the rectifier principles which are discussed in this assignment.

Test Questions

Be sure to number your Answer Sheet Assignment 23.

Place your Name and Associate Number on **every** Answer Sheet.

Submit your answers for this assignment immediately after you finish them. This will give you the greatest possible benefit from our personal grading service.

- Current flows through a rectifier tube
 - when the plate is positive in respect to the cathode.
 - when the plate is negative in respect to the cathode.
 - all of the time.
- The output from the rectifier tube in a power supply is
 - a-c.
 - pure d-c.
 - pulsating d-c.
- What is the purpose of the filter in a power supply?
- Draw a schematic diagram of a transformer type of power supply with a full-wave rectifier circuit using a rectifier tube with a **directly heated** cathode and two plates, a two-section choke-input filter, and a bleeder resistor.
- Under a light load, which power supply will have the greater voltage output,
 - one with a choke-input filter, or
 - one with a capacitor-input filter?
- Which type of power supply will have better regulation,
 - one with a choke-input filter, or
 - one with a capacitor-input filter?
- If a 60 hertz a-c is applied to the primary of a transformer, what will be the frequency of the ripple voltage if
 - a full-wave rectifier is used? *120 Hz*
 - a half-wave rectifier is used? *60 Hz*
- Draw a diagram of a half-wave rectifier using an **indirectly heated** cathode and incorporate a pi-type filter and a bleeder resistor.
- In Figure 6(C), if the polarity of the a-c voltage across the high voltage secondary winding is such that the bottom plate of the rectifier tube is positive and the top plate is negative, will current flow from the filament to the bottom plate or from the filament to the top plate?
- What would the percentage of regulation be in a power supply which delivers 400 volts under no load conditions and drops to 300 volts under full load conditions?

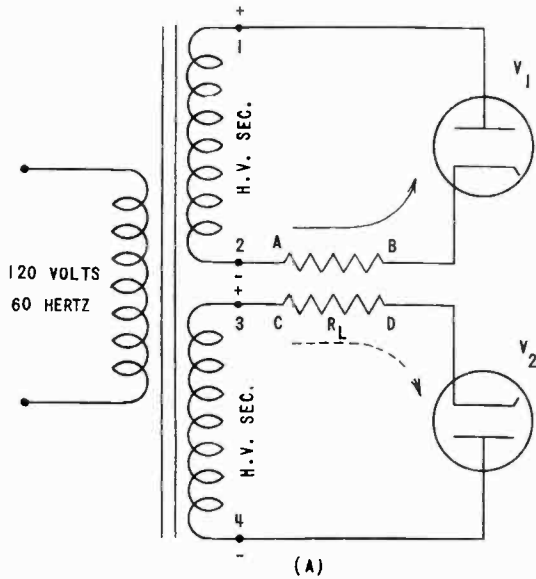

(A)

FIGURE 4

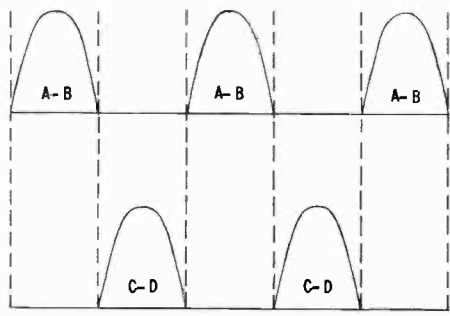

D.C. OUTPUT VOLTAGE

(B)

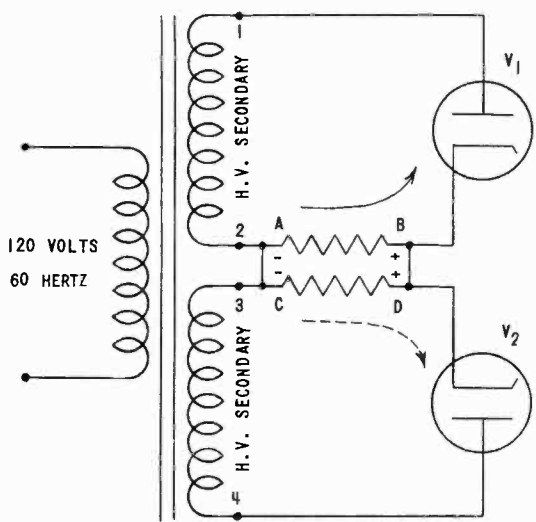

FIGURE 5-A

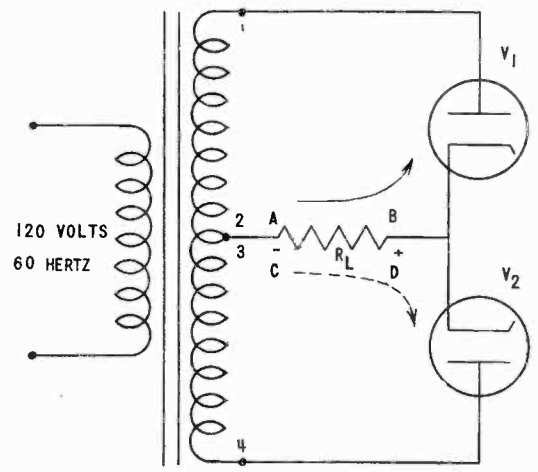

FIGURE 5-B

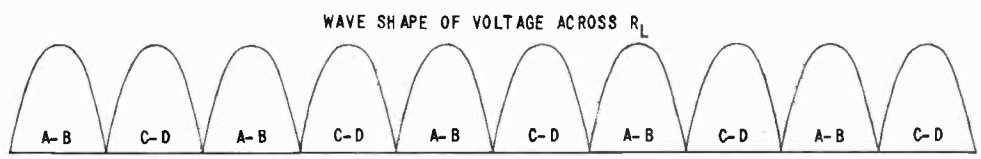

FIGURE 5-C

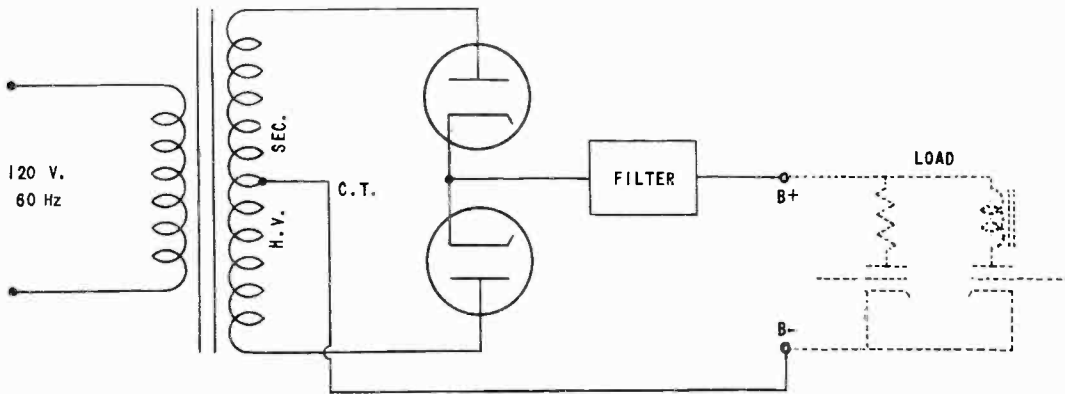

FIGURE 6-A

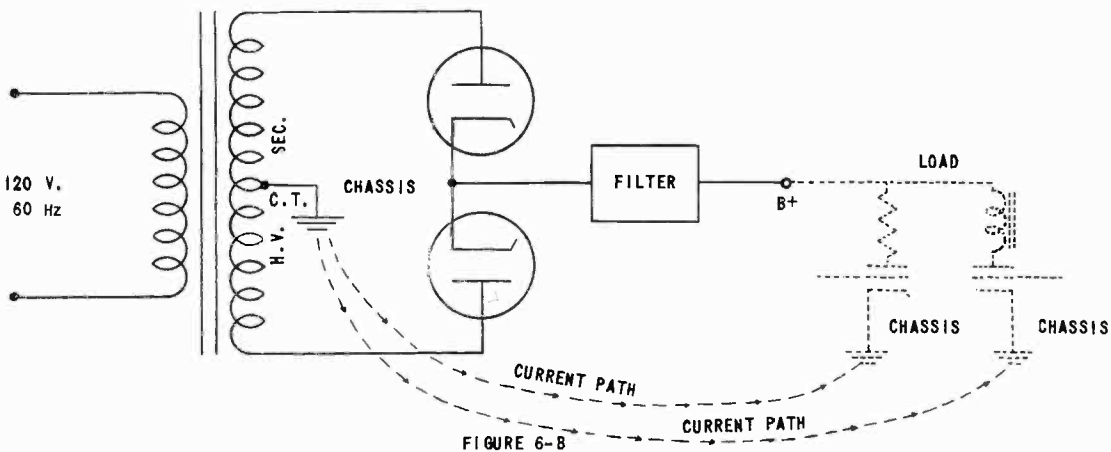

FIGURE 6-B

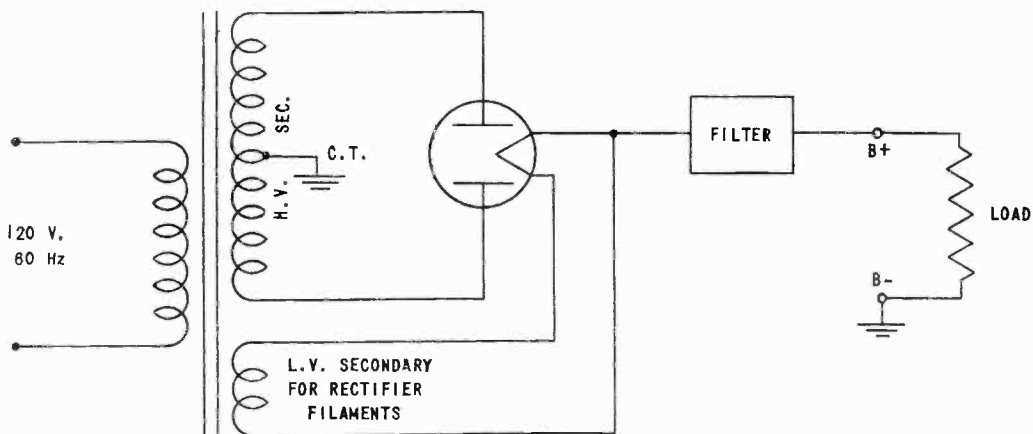

FIGURE 6-C

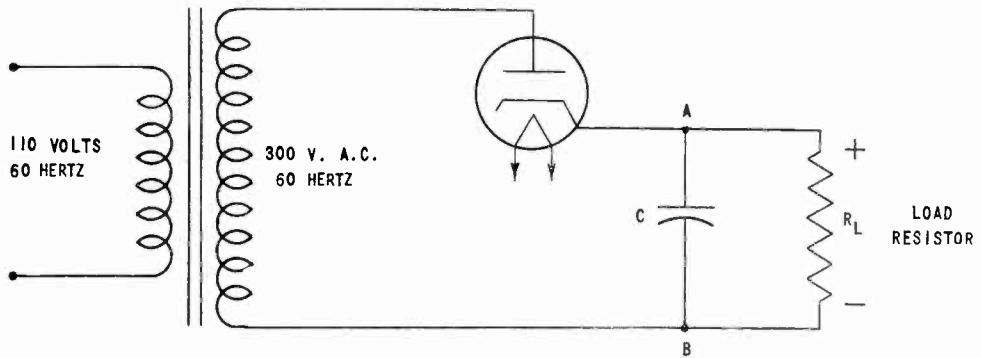

FIGURE 7

OUTPUT WAVE SHAPE WITH CAPACITOR

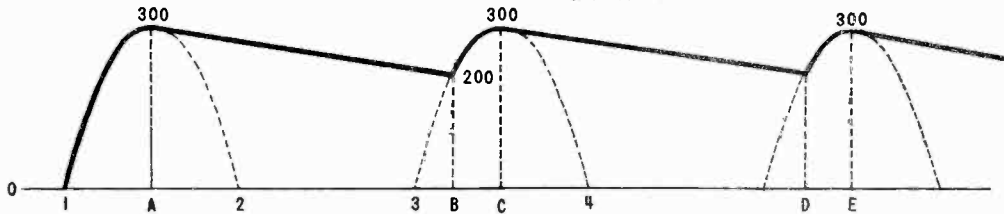

FIGURE 8

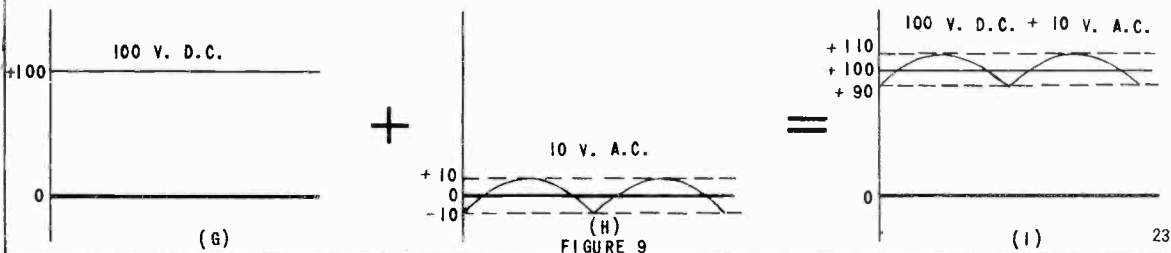
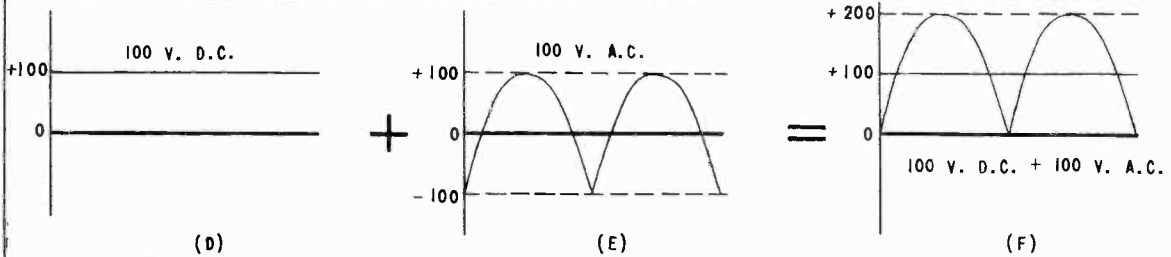
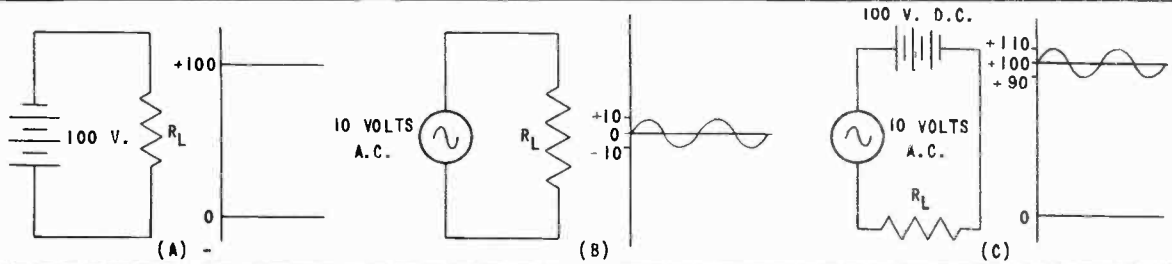

FIGURE 9

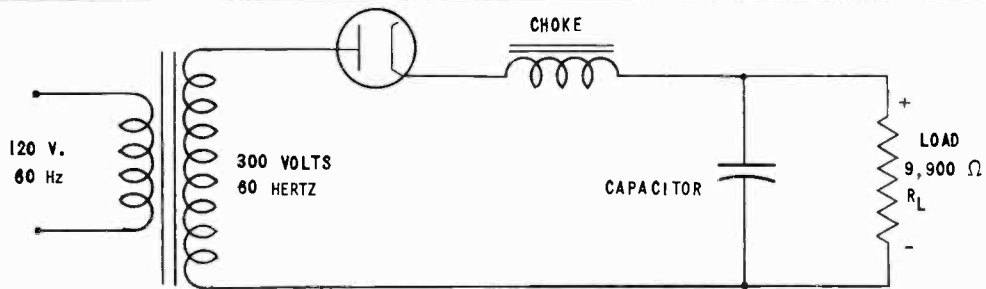
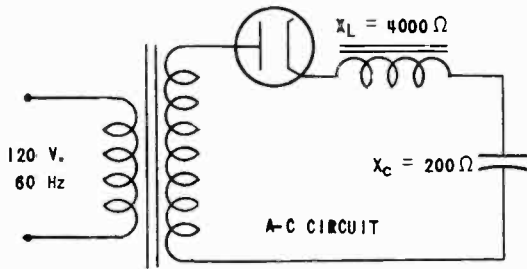
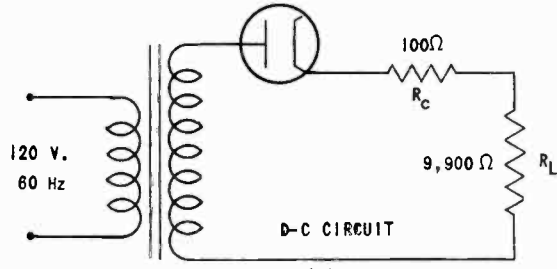

FIGURE 10



(A)



(B)

FIGURE 11

CHOKE-INPUT FILTERS

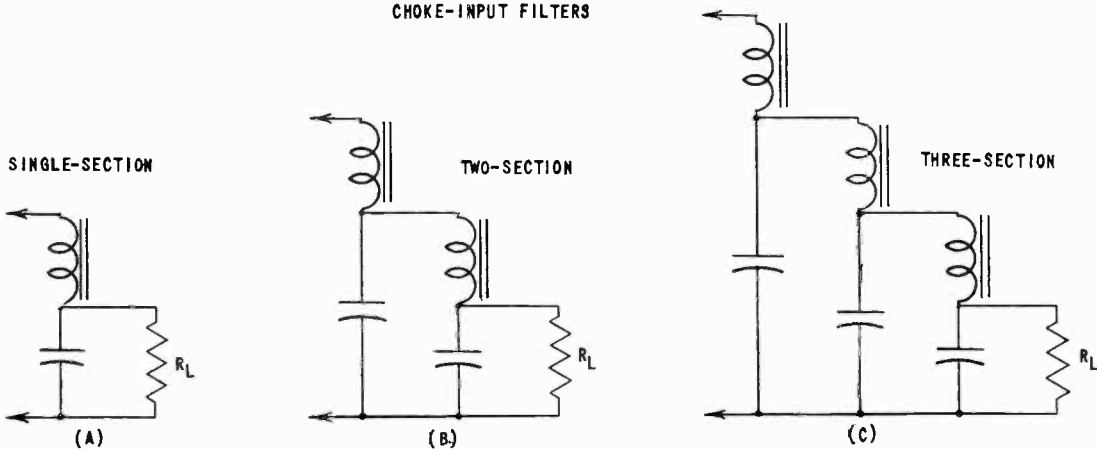
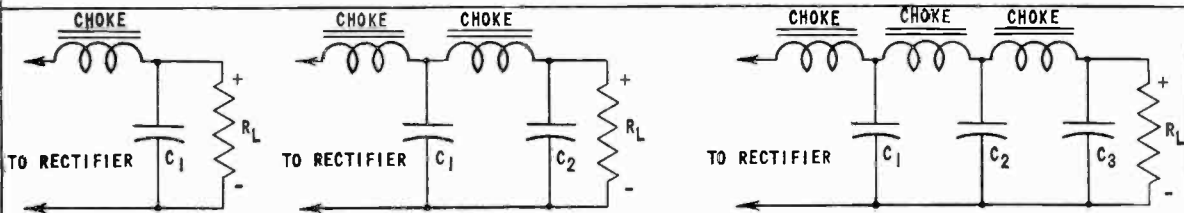

FIGURE 12



(A)

(B)

(C)

FIGURE 13

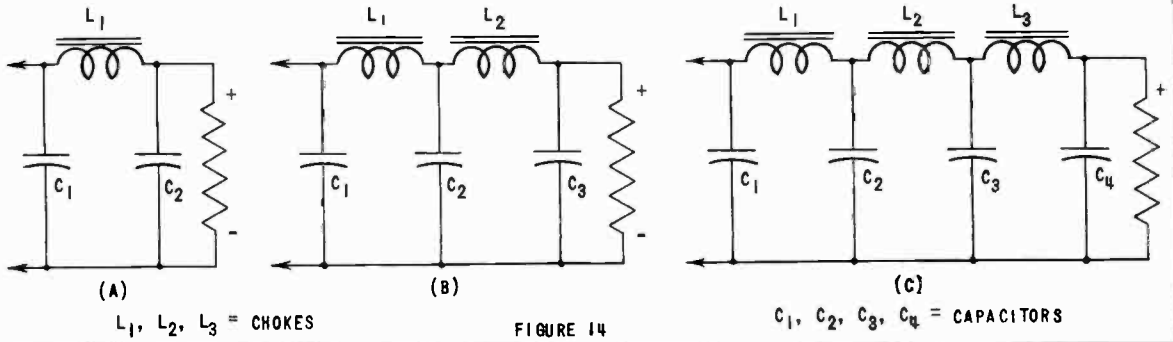

FIGURE 14

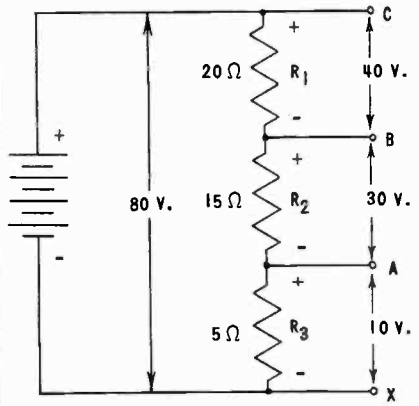

FIGURE 15

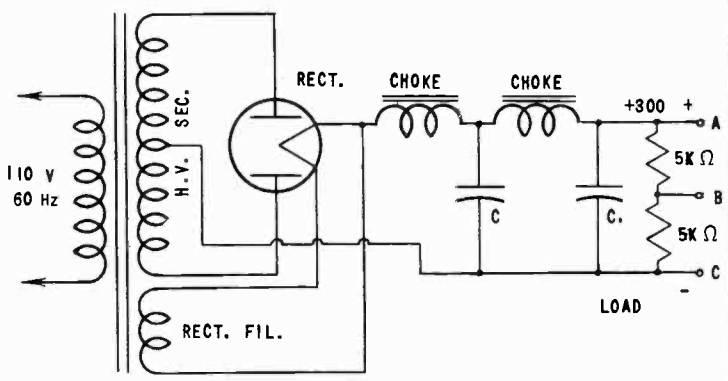

FIGURE 16

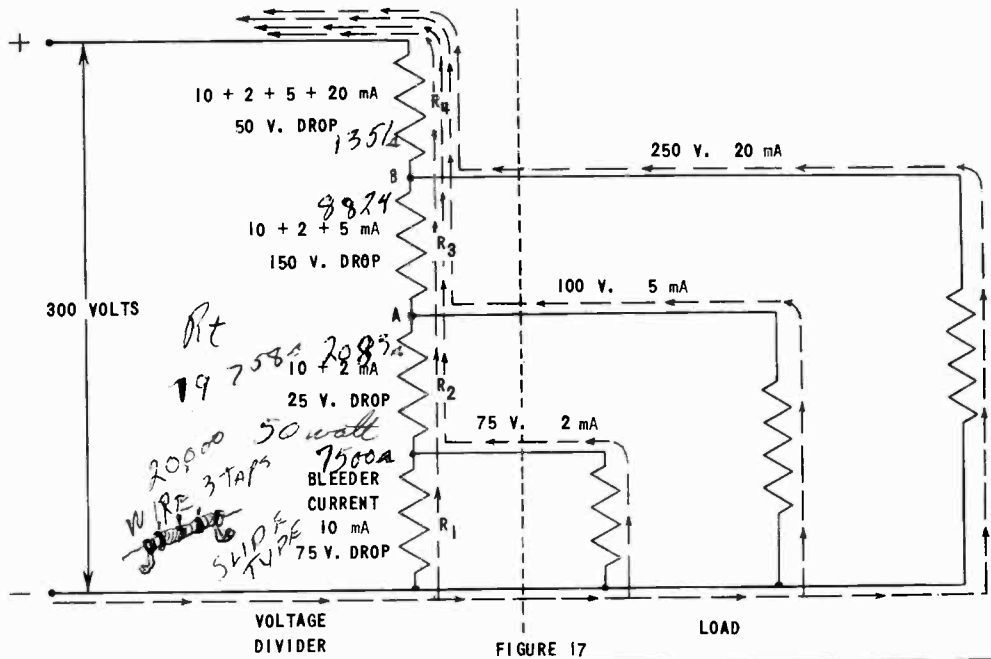

FIGURE 17

