

**OPERATING
ALIGNMENT & SERVICING
INSTRUCTIONS FOR
SKY BUDDY RECEIVER
MODEL S-19R**



the hallicrafters inc.
2611 INDIANA AVENUE
CHICAGO

OPERATING INSTRUCTIONS

Sky Buddy

Model S19-R

The model S19-R Sky Buddy is a 6 tube 4 band superheterodyne receiver covering the following frequencies:

Band 1 - 540 KC to 1700 KC
2 - 1.7 MC to 5.5 MC
3 - 5.5 MC to 17.0 MC
4 - 16.0 MC to 46.0 MC

ANTENNA

For successful operation of the receiver throughout its tuning range very satisfactory results can be obtained with an inverted "L" type antenna 75 feet long overall. When this type of antenna is used the jumper should remain connected between A2 and G.

If the operator should wish to obtain the maximum in performance from the receiver on any one frequency, it is suggested that a half wave doublet antenna cut for that frequency be installed.

The formula for calculating the overall length of this antenna is:

$$\text{Length in feet} = \frac{463}{\text{Frequency in megacycles}}$$

The antenna is cut in the center and connected to a twisted pair transmission line having a characteristic impedance of 75 ohms. The other end of this line is connected to the A1 and A2 antenna posts.

This antenna will not perform well at harmonic frequencies but should be better than the inverted "L" on the frequency for which it has been designed. Performance on the #4 band, even with a suitable antenna, is subject to varying conditions of the time of the day and year.

A ground is usually not necessary for satisfactory performance of the model S19-R Sky Buddy receiver. If a ground does prove helpful it is connected to the "G" post of the antenna terminal strip. A cold water pipe or a 6 foot rod driven into moist soil are good ground suggestions. Connections to radiators and gas piping are not advised.

CONTROLS AND OPERATION

The model S19-R Sky Buddy is equipped with conveniently arranged controls to enable the operator to realize the maximum in performance from the receiver.

MAIN TUNING

This control rotates the large calibrated dial so that the desired frequency can be easily located. The accuracy of calibration is held to close tolerances. This calibration will be correct, however, only if the "Bandspread" dial is set at "0" or minimum capacity.

"BANDSPREAD"

In no other similar receiver but the S19-R Sky Buddy can be found such extremely smooth and satisfactory electrical bandspread action. The stator plates are an integral part of the main condenser and the separate rotor sections are driven by a gearless mechanism through the separate bandspread knob.

The controls along the bottom edge of the receiver are:

SEND-RECEIVE SWITCH which, when in the "send" position, removes plate voltage from the tubes.

The BAND SWITCH allows selection of any one of the four ranges covered by the receiver. The newly incorporated 10 meter band will prove to be most interesting when conditions are favorable for reception on that range.

The B.F.O. "ON-OFF" SWITCH allows optional use of the Beat Frequency Oscillator and is used when the operator is copying code signals. It will be of additional help in locating weak fone signals by first locating their carrier. Once located, the B.F.O. may then be turned off to eliminate the whistle.

The PITCH-CONTROL Knob allows the operator to vary the pitch of the beat note when the BFO switch is in the "on" position. Selection of the pitch of the beat note most pleasing to the operator will be of help in copying through interference. The A.V.C. "OFF" and "ON" Switch is for optional use of automatic volume control. Should the strength of the telephone signal be so strong as to block the receiver the A.V.C. switch should be "on". For maximum sensitivity leave the AVC switch "off" and manually adjust the gain of the receiver with the audio gain control.

The receiver is turned on and off with this control and additionally provides variation of the volume delivered by the receiver to suit the requirements of the listener.

A Headphone Jack is mounted on the panel to the right of the Pitch Control Knob. When headphones are used, inserting the phone plug in the jack automatically disconnects the speaker.

The tube lineup of the S19-R Sky Buddy is as follows:

- 6K8G 1st Detector - mixer
- 6K7G IF Amplifier
- 6Q7G 2nd Detector - 1st stage of audio
- 41 2nd Audio Amplifier
- 76 BFO
- 80 Rectifier

The Sky Buddy, model S19-R draws 50 watts at 117 volts, 60 cycles A.C.

The Hallicrafters, Inc., reserve the right to make changes in design or to add improvements to instruments of their manufacture without incurring any obligation to install the same in any instrument previously purchased.

ALIGNMENT PROCEDURE FOR SKY BUDDY MODEL S19-R

I. F. ALIGNMENT

Have the controls set as follows:

Audio gain control at maximum

A.V.C. switch "on".

Range switch on Band #2.

Set main dial to minimum capacity 5.5 M.C. position

Remove 6K8 grid cap and connect signal generator to this tube.

Set signal generator for 455 KC output.

Adjust trimmers on transformers T1, T2 for maximum output.

For adjustment of the B.F.O., place the BFO switch in the "on" position. Remove the knob from the pitch control shaft. You will see a small adjustment screw in the center of this shaft. On the under-chassis side of this shaft you will see a set screw which should be loosened in order to allow adjustment of the screw in the center of the pitch control shaft. Adjust to zero beat. Tighten the set screw and replace the knob. Should the BFO still fail to operate check the .0005 condenser in the BFO circuit, or the 76 BFO tube.

R. F. ALIGNMENT

Connect the generator to the A1 terminal on the antenna terminal strip found on the rear apron of the chassis through a 400 ohm resistor. Leave the jumper connected between A2 and G. The trim and pad points for the 4 bands are indicated below:

Set the signal generator to the required frequencies for each band, adjust the main tuning dial to those frequencies (with the bandspread condenser at minimum capacity) and then adjust the indicated trimmers and padders to resonance.

Trim	Band 1	Pad
1400 KC Adjust C _A C _E		600 KC Adjust C ₂₄
4 MC Adjust C _B C _F	Band 2	2 MC Adjust C ₂₅
14 MC Adjust C _C	Band 3	None-check at 7 MC
30 MC Adjust C _D C _H	Band 4	None-check at 18 MC

On the two high frequency bands where no padding adjustments are found, the checking frequencies should fall within 1 division of the dial calibration with no further adjustments.

During the R.F. alignment process it is advisable to "Rock" the main tuning condenser across the frequency on which you are making adjustments to the receiver. Once the exact point of maximum output is obtained further adjustment is unnecessary.

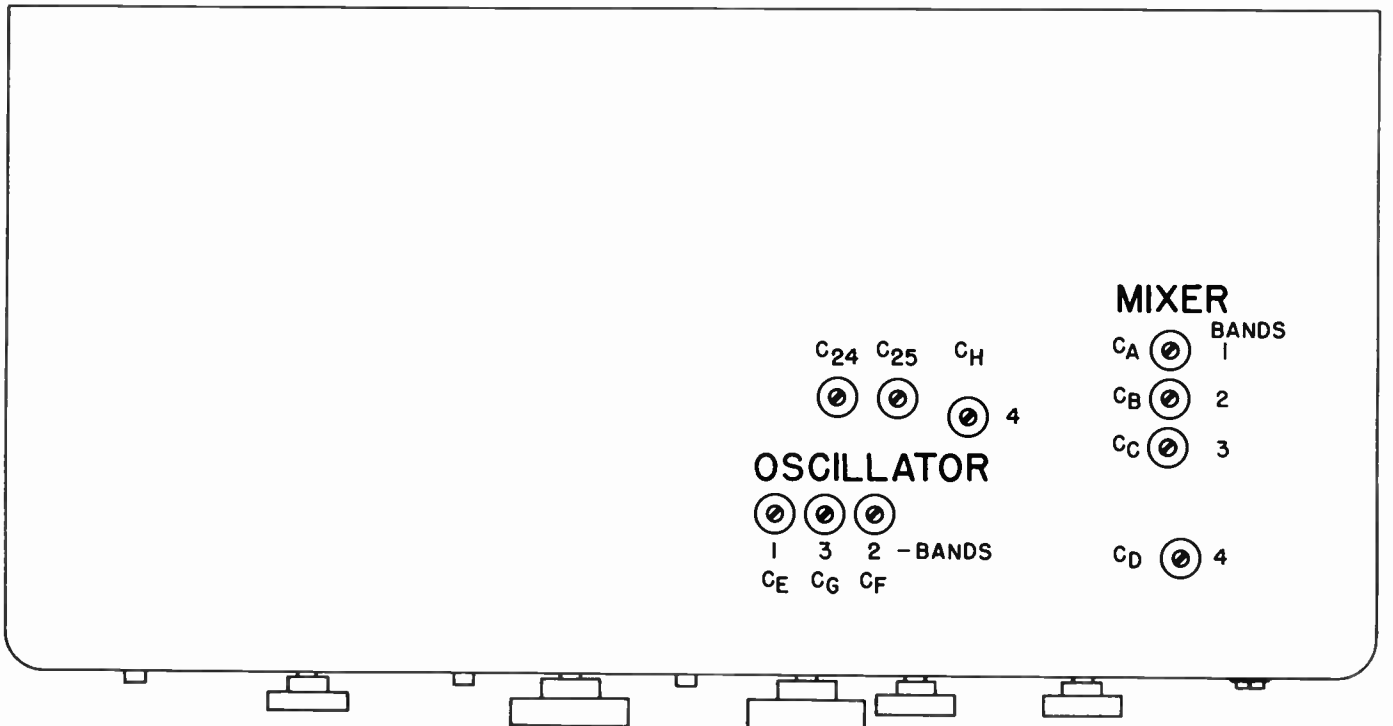
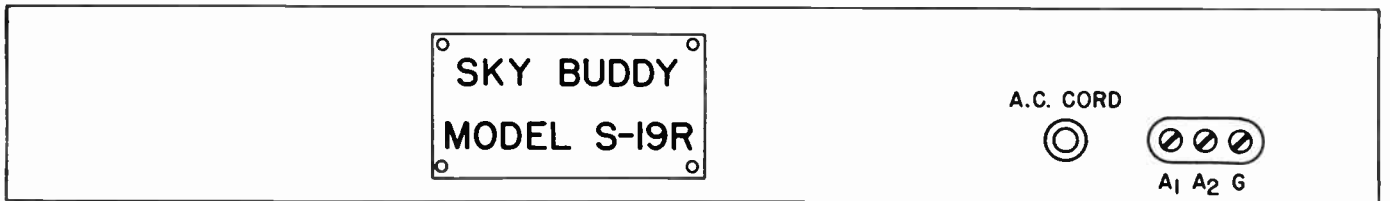
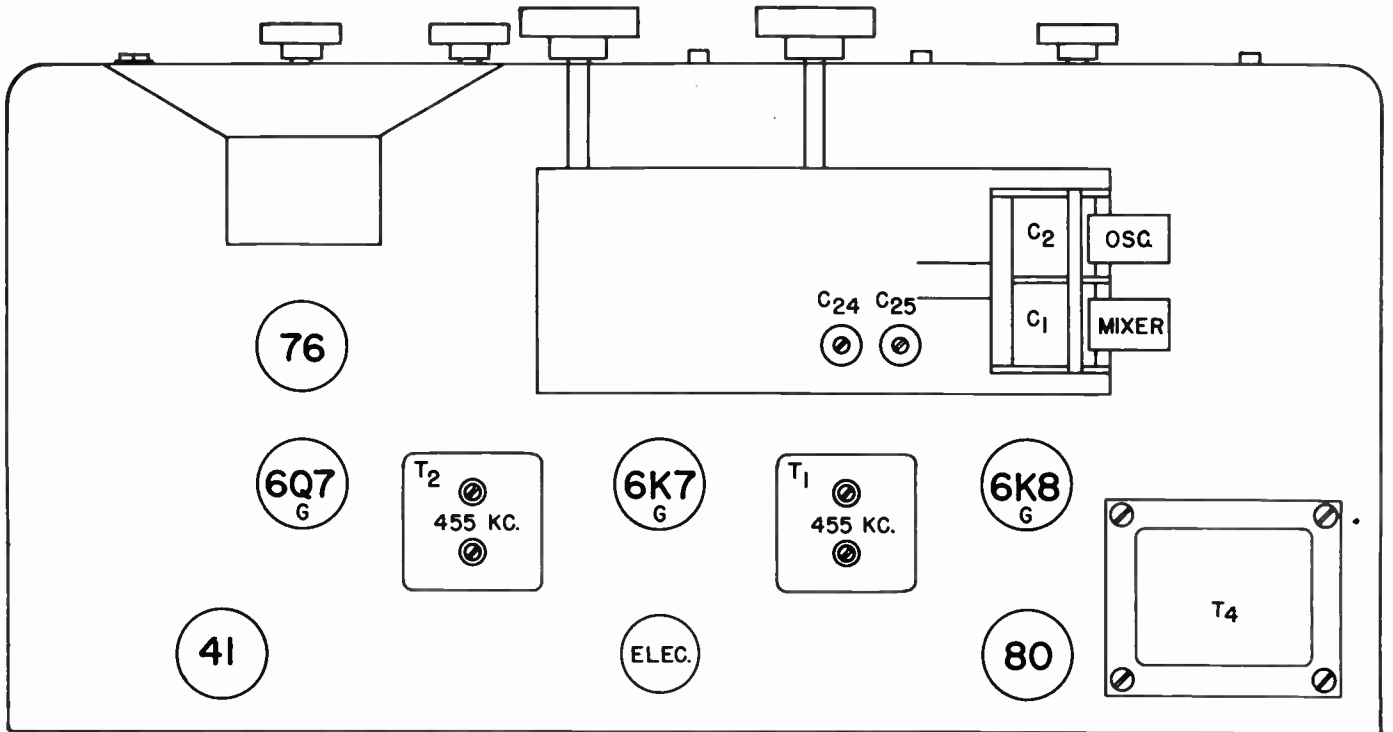

S19R CONDENSER PARTS LIST

NO.	CAPACITY	TYPE	VOLTAGE
C1	.000375 mfd.		
2	"	Maintaining	
3	.05		200
4	.01		400
5	.05		200
6	.05		200
7	10		300
8	.05		200
9	.0001	Mica	
10	.0001	"	
11	.02		200
12	.1		200
13	.02		200
14	10		25
15	.01		600
16	.1		400
17	.01		400
18	.0001	Mica	
19	.0005	"	
20	10		300
21	10		350
22	.01		600
23	.0001	Ceramic	
24	.000375	Pad	
25	.001	"	
26	.0043		
27	.0001	Mica	
28	.01		600

S19R RESISTOR PARTS LIST

NO.	OHMS	WATTAGE
R1	300	1/3
2	50000	"
3	10000	1
4	500	1/3
5	3500	"
6	25000	1
7	50000	1/3
8	300	"
9	1000000	Variable
10	500000	1/3
11	250000	"
12	1000000	"
13	600	1/2
14	50000	1/3
15	50000	"
16	3000	1/2
17	10000	1/2

SWITCHES

SW	
1	A.V.C. on - off
2	Send - Receive
3	BFO on - off

SCHEMATIC DIAGRAM—SKY BUDDY—MODEL S-19R

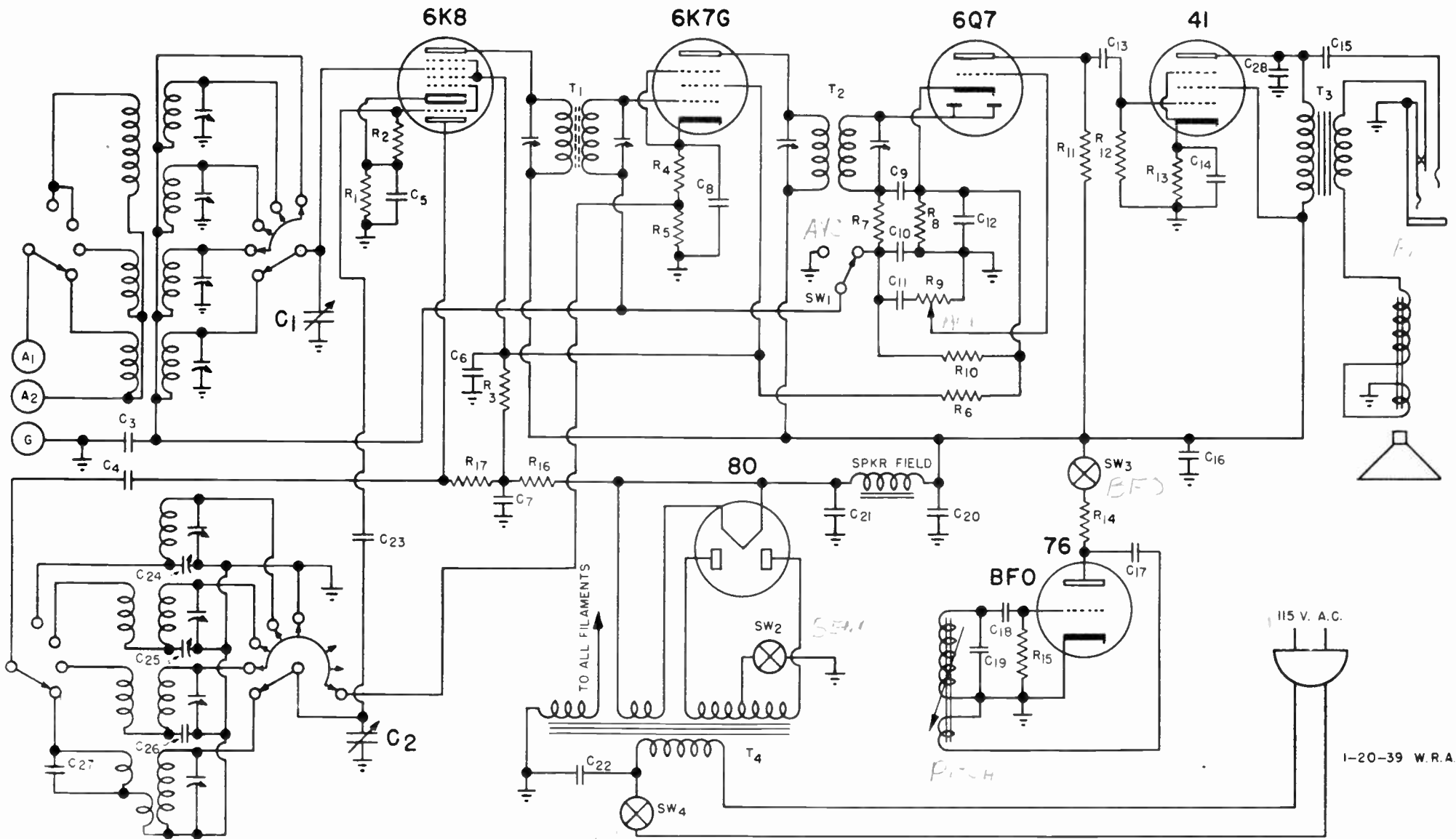

I-20-39 W.R.A.

