

200

# WCFL

WORLD CO-OPERATIVE FARMER-LABOR

## Quarterly Radio Magaz.

# Radio



The Voice of  
**FARMER-  
LABOR**

**SPRING  
1929**



**35c**

WHEN DAY IS DONE

# Get the Newest Things in Radio By Ordering Direct from this Page

To demonstrate the quick service of Barawik Company to the readers of WCFL we give them opportunity to order the new items listed below, direct from this page. And, the same day your order is received, the goods will be shipped to you.

These timely bargains are typical of thousands listed in our big 364-page 1929 catalog, just off the press. In it you will find the best there is in radio, electrical supplies and appliances, auto tires and accessories, sporting goods and household specialties. We invite

every reader of WCFL to secure a copy of this book—sent FREE!—without obligation.

We believe our prices are the lowest obtainable. Our terms are cash C. O. D. or remittance with order, just as you wish. We have thousands of customers everywhere. We are pioneers in the radio field and inquiry will show that we are a large, reliable house. You are guaranteed complete satisfaction with any article you buy from us. Send us your order direct from this page but if you don't find what you want here, ask for your copy of our big new catalog, Free.



**Dynamic Speaker Hum Eliminator**

Connect across field coil of any dynamic speaker with the snap connectors attached to it. Positively blots out AC hum. Every owner of a dynamic speaker should have it to insure sweet, even reproduction, devoid of annoying hum. Shpg. wt., 3 lbs.

2B305—List, \$3.50. Net. **\$2.06**



**Dynamic Speaker Control**

For AC sets with separate dynamics. The Thermatrol places entire control of speaker automatically in set switch. Eliminates snapping two switches and danger of leaving speaker on when set is off. NO WIRING. Just plug it into wall outlet. Shpg. wt., 2 lbs.

3B730—List, \$2.50. Net. **\$1.47**



**Stop A C Noises With Falk Clarceptor**

Electrical interference noises caused by telephones, street cars, elevators, motors and countless electric devices flood in over the AC wires and are heard as blare, squeal, fry and scratch. Blot them out with the Clarceptor. It plugs into light socket ahead of set. It grounds and blocks out line interference noise and disturbances. Improves selectivity and distance. No changes in set necessary. Tested and proved—praised by thousands. Size only 3½x5½x2½ in. Shpg. wt., 6 lbs.

2B1524—List, \$7.50. Net. **\$4.41**



**Kabinettenna**

Fasten to back or inside of cabinet or console. Plugging into the light socket, the Kabinettenna provides electric power for the dynamic speaker and radio set with only one plug in the wall or light socket. Reduces static and eliminates all lightning hazards. Easy to install. Makes neatest possible installation. Shpg. wt., 3 lbs.

3B2691—List, \$4.50. Net. **\$2.65**



**Dumont Socketenna With Two Outlets**

In addition to providing an ideal antenna, it provides two electrical outlets into which radio set, dynamic speaker, or electrical appliances may be plugged. The Socketenna is a vast improvement over ordinary light socket aerials because of this dual feature. Installed with your radio it eliminates the use of outside aerials, and consequently does away with lightning hazards. Made of genuine Bakelite and consumes no current whatsoever. Shpg. wt., 1 pound.

3B2701—List, \$1.25. Net. **73c**



**Clarostat Socket Antenna**

Makes any socket or convenience outlet an antenna. Improves radio reception whether used alone or as a "booster," in combination with usual antenna or loop. Usually adds more distance and selectivity to any set as well as eliminates a great deal of static.

3B2724—List, \$1.50. Net. **88c**

## Pioneer Radio Servicer for the Radio Service Man

Tests sets, tubes, power units, line voltages and provides space for tools and supplies. A new unique method of plug-in meters allows the testing of every kind of AC and DC radio set, as well as all kinds of AC and DC tubes. Made for us by a prominent meter manufacturer, this new complete radio service tester fulfills the wants of every radio service man and engineer. Plug-in meters included are: 0-10 volts AC or DC, double range milliammeter 0-20-100 with trip switch, 0-500 high resistance B eliminator volt-meter, 0-150 volts AC, 30-inch test leads and cord with four and five-prong adapter for plugging into receiver are also included. Inbuilt switch allows grid bias to be easily read. Over all size, 11 by 7½ by 14 inches wide. Shpg. wt., either type, 20 pounds.

3B1732—Standard Model, as illustrated. List, \$45.00. Net. **\$26.46**

3B1733—DeLuxe Model. Same as above except lower section is fitted with five plush lined drawers. List, \$55.00. Net. **\$32.34**

**Terra-Tenna**

Radio's newest antenna device. Provides all the advantages of an underground antenna and is recommended where space is limited. The Terra-Tenna can be installed anywhere. Simply connect one side to the antenna post and the other side to a water pipe or other ground connection. Gives wonderful clarity on local and distant stations alike, increasing selectivity, reducing static, and eliminating all lightning danger. Very simple to install. Shpg. wt., 6 lbs.

3B2690—List, \$5.00. Net. **\$2.94**



**Aerial Clamp**

The aerial clamp is easily attached, easily removed and stays tight. Threaded shaft is Cadmium plated and will not rust. Clamp itself is of heavy iron Cadmium plated. Delivered complete with insulator and bolts. The aerial clamp can't be beat for either temporary or permanent installations. Shpg. wt., 6 lbs.

3B2693—List, \$2.50. Net. **\$1.47**



**AC Set Outlet Plate**

Two Tip Jacks with "Imp" plugs for Aerial and Ground connections. A 1½ inch hole cut for standard electric receptacle. (No receptacle furnished.)

3B2370—Plain Brass. List, \$1.00. Net. **59c**

3B2371—Brown Bakelite. List, \$1.25. Net. **73c**

3B2372—Statuary Bronze (Illustrated). List, \$2.25. Net. **\$1.32**

**MARVELO Radio Sets**

The new issue of the 1929 Barawik Radio Book contains a complete listing of the famous Marvelo Radio Sets, both AC and DC. The most amazing values in line receivers in America today. Noteworthy is the new Trio-Dynamik, the most unusual, highly developed receiver yet produced. Don't buy a set until you see the Marvelo. A copy of the new Barawik Book will be sent free on request.

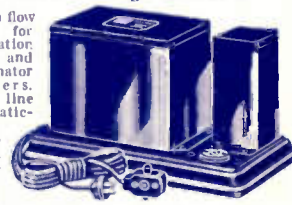

**Automatic Voltage Control**

Produces even flow of AC needed for successful operation of All Electric and A and B eliminator driven receivers. Regulates local line voltage automatically. No tubes, liquids, nor are there hand switches or rheostats. Compensates sudden fluctuations. Protects 227 tubes against surge burn-outs, and guarantees longer life to all other tubes. Compact in size, magic in performance. Size 4x7½x4 inches. Shpg. wt., 10 lbs.

3B5210—List, \$15.00. Net. **\$8.40**



**Silver-Marshall Dynamic Speaker**

New improved design and construction. Bringing out all frequencies with equal amplification and being hum-free. It makes the ideal reproducer for the new AC sets. Has inbuilt universal output transformer. Uses 280 rectifier tube (tube not included). Shpg. wt., 25 lbs.

3B5385—S-M 850. For 105-120 volt 60 cycle AC. List, \$58.50. Net. **\$34.40**

3B5386—S-M 851. For 90-120 volt DC. List, \$48.50. Net. **\$28.51**



**Tobe Filterettes**

The new Tobe Filterettes filter out line noises from motors, etc. They allow radio set to be operated without AC line interference.

Filterette Junior, AC or DC where not more than 500 watts are being drawn from line.

3B376—List, \$3.50. Net. **\$2.06**

3B377—Filterette No. 11. For use where wattage does not exceed 1000 watts. List, \$10.00. Net. **\$5.88**

3B379—Filterette No. 110. For use where wattage does not exceed 500 watts. List, \$15.00. Net. **\$8.82**



**Potter Interference Eliminator**

Disturbing noises in radio sets created by electrical appliances and devices which interfere greatly with broadcast reception, can be successfully eliminated by the use of a Potter Interference Eliminator. Simply connect filter to AC line at point of interference. Takes only a minute to install.

3B432—Type 105-05. Line voltage, 110. List, \$3.75. Net. **\$2.21**

3B449—Type 305-05. Line voltage, 220. List, \$6.50. Net. **\$3.82**

*The Barawik Co.*

129 North Jefferson St.  
CORNER OF RANDOLPH  
CHICAGO :: ILLINOIS

# Use the Mails Without Cost!

## No Postage Stamps Needed

YOU can answer any advertisement in this issue of WCFL RADIO MAGAZINE, or get any desired information, without going to the trouble of writing a letter or buying a postage stamp. A new postal regulation makes it possible for us to offer this unusual service to our readers.

### Use the Postage-Free Reply Cards at Foot of This Page

Just check the subjects that interest you, sign your name and deposit the card in the nearest mail box. Uncle Sam will collect the postage from us—and we'll see that you get the information requested. What could be handier! Check as many subjects as you desire, or write on any subject that interests you. Replies will be full and prompt.

Here is just the convenience you long have

sought! Often you have wanted information regarding subjects mentioned in your favorite magazine, but have been deterred from writing because an envelope had to be addressed to enclose the coupon and a stamp procured to carry it. Addressing envelopes is a bother—and stamps are never handy when most needed. We have eliminated all this bother—now you can answer advertisements as you read.

### No Letter Is Needed — No Stamp Required

Never before has such a convenient service been provided for magazine readers. We want you to use it freely. Absolutely no obligation is involved. One card would suffice, but we want you or some other reader to have cards handy for future use, so we are supplying three. Detach the cards one at a time as used, then they

will always be handy when needed. Fill in one of the cards today and be the first to enjoy this novel and exceptional service afforded only by WCFL Radio Magazine. Use one of the cards as a bookmark, checking subjects in which you are interested as you read; when you have finished reading, mail the card.

### Response Will Be Almost As Speedy As Radio

Detach cards only as used, then one will always be handy when needed.

FIRST CLASS  
Permit No.  
2197  
(Sec. 384 1/2 P L & R)  
CHICAGO, ILL.

#### BUSINESS REPLY CARD

NO POSTAGE STAMP NECESSARY IF MAILED BEFORE DEC. 31, 1929

2c—POSTAGE WILL BE PAID BY—2c

### WCFL RADIO MAGAZINE

623 SOUTH WABASH AVENUE

CHICAGO, ILL.

Editor WCFL Radio Magazine:  
Send information regarding.....

Also information on subjects checked below:

- |   |   |
|---|---|
| <input type="checkbox"/> Allied Radio Catalog                       | <input type="checkbox"/> Elgin Watches                                    |
| <input type="checkbox"/> Barawik Co.                                | <input type="checkbox"/> Nurito   |
| <input type="checkbox"/> CeCo Radio Tubes.                          | <input type="checkbox"/> Federation News.                                 |
| <input type="checkbox"/> Chi. Salvage Stock Catalog                 | <input type="checkbox"/> Farmers Union.                                   |
| <input type="checkbox"/> Clarostat Mfg. Co.                         | <input type="checkbox"/> Newark Electric Co.                              |
| <input type="checkbox"/> Gold Seal Radio Tubes                      | <input type="checkbox"/> Walker Multi-Unit.                               |
| <input type="checkbox"/> Enco Loud Speakers                         | <input type="checkbox"/> Hi-Q 29 (Hammarlund-Roberts)                     |
| <input type="checkbox"/> National Radio Institute                   | <input type="checkbox"/> Renuzit for Automobiles                          |
| <input type="checkbox"/> I want to join the Junior Federation Club. | <input type="checkbox"/> Send WCFL Radio Magazine and bill me for \$1.25. |
| <input type="checkbox"/> Send information about Free Radio Course.  |   |

Name..... Please print your name  
Street or R. R..... Date.....  
Postoffice..... State.....

**FREE** Answer the following questions and a copy of Haynes' Radio Log will be sent to you free of cost.

- WCFL comes in strong.  
 WCFL is hard to tune in.  
 WCFL is smeared by.....  
 Interference is worst at..... p. m.  
 Programs we like best are.....

- Townsend "B" Power Unit  
 Underground Aerials  
 Woodstock Typewriters

Editor WCFL Radio Magazine—

Please send information on.....

Also on the subjects checked below:

- Allied Radio Catalog  
 Barawik Co.  
 CeCo Radio Tubes  
 Clarostat Mfg. Co.  
 Chi. Salvage Stock Catalog  
 Elgin Watches  
 Enco Loud Speakers  
 Federation News  
 Farmers Union  
 Gold Seal Radio Tubes  
 Hi-Q 29 (Hammarlund-Roberts)  
 Newark Electric Co.

**FREE** Answer the following questions and a copy of Haynes' Radio Log will be sent to you free of cost.

- WCFL comes in strong.  
 WCFL is hard to tune in.  
 WCFL is smeared by.....  
 Interference is worst at..... p. m.  
 Programs we like best are.....

- Underground Aerials  
 I want to join the Junior Federation Club.  
 Send WCFL Radio Magazine and bill me for \$1.25.  
 Send information about Free Radio Course.

Name..... Please print your name  
Street or R. R..... Date.....  
Postoffice..... State.....

# Free CATALOG

Our Magnificent New 1929  
98 Pages of Big Radio Bargains



## Big Discounts to Dealers & Set Builders

Our beautifully illustrated 1929 Catalog is filled with unequalled radio bargains due to our enormous buying power. Nationally famous sets, every imaginable radio part, kits, accessories and latest circuits are priced and described in detail. Order at once from the World's Largest Radio Store.



24 Hour Service Guaranteed on All Mail Orders

## Chicago Salvage Stock Store

WHOLESALE DEPARTMENT W.B. 4

509 S. STATE ST., CHICAGO, ILL.

Editor WCFL Radio Magazine  
Send information regarding.....

.....  
.....

Also information on subjects checked below:

- |   |   |
|---|---|
| <input type="checkbox"/> Allied Radio Catalog                             | <input type="checkbox"/> Elgin Watches                |
| <input type="checkbox"/> Barawik Co.                                      | <input type="checkbox"/> Nurito                       |
| <input type="checkbox"/> CeCo Radio Tubes                                 | <input type="checkbox"/> Farmers Union                |
| <input type="checkbox"/> Chi. Salvage Stock Catalog                       | <input type="checkbox"/> Federation News              |
| <input type="checkbox"/> Clarostat Mfg. Co.                               | <input type="checkbox"/> Newark Electric Co.          |
| <input type="checkbox"/> Gold Seal Radio Tubes                            | <input type="checkbox"/> Walker Multi Unit            |
| <input type="checkbox"/> Ensclo Loud Speakers                             | <input type="checkbox"/> Hi-Q 29 (Hammarlund-Roberts) |
| <input type="checkbox"/> National Radio Institute                         | <input type="checkbox"/> Renuzit for Automobiles      |
| <input type="checkbox"/> I want to join the Junior Federation Club.       |   |
| <input type="checkbox"/> Send WCFL Radio Magazine and bill me for \$1.25. |   |
| <input type="checkbox"/> Send information about Free Radio Course.        |   |

**FREE** Answer the following questions and a copy of Haynes' Radio Log will be sent to you free of cost.

- WCFL comes in strong.  
 WCFL is hard to tune in.  
 WCFL is smeared by.....  
 Interference is worst at.....p. m.  
 Programs we like best are.....

- Townsend "B" Power Unit  
 Underground Aerials  
 Woodstock Typewriters

Name..... Please print your name  
 Street or R. R..... Date.....  
 Postoffice..... State.....

FIRST CLASS  
Permit No.  
2197  
(Sec. 384 1/2 P L & R)  
CHICAGO, ILL.

## BUSINESS REPLY CARD

NO POSTAGE STAMP NECESSARY IF MAILED BEFORE DEC. 31, 1929

2c—POSTAGE WILL BE PAID BY—2c

## WCFL RADIO MAGAZINE

623 SOUTH WABASH AVENUE,

CHICAGO, ILL.

BUSINESS REPLY CARD

NO POSTAGE STAMP NECESSARY IF MAILED BEFORE DEC. 31, 1929

2c—POSTAGE WILL BE PAID BY—2c

WCFL RADIO MAGAZINE

623 SOUTH WABASH AVENUE,

CHICAGO, ILL.

FIRST CLASS  
Permit No.  
2197  
(Sec. 384 1/2 P L & R)  
CHICAGO, ILL.

# WCFL Radio Magazine

*The Voice of Farmer-Labor*

OFFICIAL QUARTERLY PUBLICATION OF

WCFL RADIOPHONE BROADCAST STATION

and the Co-operative Farmer-Labor Radio Listeners' Association

WCFL Radiophone Broadcast Station was established and is owned by the Chicago Federation of Labor. In the maintenance and operation of the station, Organized Farmers and Co-operatives are participating with Union Labor through membership in the Co-operative Farmer-Labor Radio Listeners' Association. The WCFL Transmitter is located on the Navy (formerly Municipal) Pier, Chicago, Ill., and operates on a wavelength of 309.1 meters (970 kilocycles) by authority of the Federal Radio Commission. Studios and offices of Station WCFL are located at 623 South Wabash Avenue, Chicago.

## Radio's Amazing History

IT is only thirty-two years since young Marconi went to London to lay before government authorities the result of his experiments in turning the discoveries of the Hertzian rays to practical use. About that time the writer, then a forward-looking collegian, heard a crowd of skeptical students boo a visionary professor for declaring that we would live to see the days when electrical messages would be sent without wires. It is less than twenty years since the rescue of all of the endangered human beings in the rammed steamship Republic taught the world about the new and astounding agency of safety for those in peril on the sea. It is only about fifteen years since the experiments were begun that gave birth to broadcasting. And in all this short time there has been a continuity of experiment, of development, and also almost a continuous succession, in one way and another, of disagreement, business parleying, diplomacy, and lawsuits.

Because of the wide ramifications of the subject the record of radio is sure of an interested hearing from lay readers generally. Founded upon science, and a very abstract science at that, the superstructure of radio has been built up through the work of the practical inventor, the business man, the statesman and the diplomat. And the structure is not yet complete. What its future will be no one knows. The story of radio is a drama of marvelous breadth to be written in the future. It cannot be now.—*Edwin P. Reese.*

## Contents of Spring Issue

|  |    |
|--|----|
| Byrd Expedition Has Elaborate Radio Equipment..... | 12 |
| Broadcasts by the Editor.....                      | 18 |
| Co-operation vs. Competition.....                  | 38 |
| Equality in Radio Is All That Labor Seeks.....     | 20 |
| Farmers Union Section.....                         | 37 |
| Flashes of Radio Progress.....                     | 17 |
| Free Course in Radio and Television.....           | 76 |
| Hammarlund-Roberts Jr. Hi-Q 29.....                | 23 |
| Help Wanted.....                                   | 33 |
| How to Get Best Results from A.C. Sets.....        | 11 |
| Humor.....   | 72 |
| In Charge of WCFL Programs.....                    | 60 |
| Junior Federation of Labor.....                    | 27 |
| Junior Federationists Pictured.....                | 28 |
| Kind Remarks About Hypocrites.....                 | 50 |
| Letters that Reach the Editor.....                 | 48 |
| Log of WCFL Broadcasts.....                        | 30 |
| Low Down on the Farmer-Labor Tie-up.....           | 34 |
| More Than Flights of Fancy.....                    | 72 |
| On the Road to the Spirits' Abode.....             | 16 |
| Popular WCFL Entertainers.....                     | 26 |
| Results of Recent Inventions.....                  | 36 |
| Radio Controls the Nation.....                     | 8  |
| Radio Vella Cook's Big Opportunity.....            | 74 |
| Screen-Grid Find-All Four.....                     | 44 |
| Solving Television Problems.....                   | 24 |
| Screen-Grid Short-Wave Adapter.....                | 46 |
| The Art and Practice of Farming.....               | 40 |
| The Man Who Came Back.....                         | 66 |
| Television Broadcasts Resumed by WCFL.....         | 14 |
| WCFL Music Makers.....                             | 10 |
| What is IT All About?.....                         | 42 |
| What the Kiddies Write About.....                  | 29 |

WCFL Radio Magazine is published quarterly by the Co-operative Farmer-Labor Radio Listeners' Assn. Entered as second-class matter Oct. 10, 1927, at postoffice at Oak Park, Ill., under act of March 3, 1879. Copyright 1929 by Co-operative Farmer-Labor Radio Listeners' Assn. Single copy, 35c. Annual subscription, \$1.25 in U. S. and Canada; foreign, \$2.00. Office of publication, 720 North Ridgeland Avenue, Oak Park, Ill. Address all editorial communications to the Editorial and Executive Offices, 623 South Wabash Avenue, Chicago, Illinois. Telephone Harrison 1182. WCFL Radio Magazine Technical Board: Ernest R. Pfaff, John Hannen, W. B. Pack; Virgil A. Schoenberg, Chairman.

EDWARD N. NOCKELS, Editor and General Manager  
L. W. AINSWORTH, Associate Editor, Des Moines, Ia.

January—February—March, 1929

Volume 2—Number 2

# George W. Walker's MULTI-UNIT

*A Device with a Dozen Uses*

SHORT WAVE RECEIVER  
REGULAR BROADCAST RECEIVER  
SCREEN GRID PRE-AMPLIFIER  
EXTRA STAGE OF R. F. OR "BOOSTER"  
SINGLE DIAL CONVERTER  
RADIO "EXPERIMENTAL" UNIT

CRYSTAL RECEIVER  
WAVE TRAP  
SHORT WAVE ADAPTER  
REMOTE CONTROL ADAPTER  
AUDIO OSCILLATOR  
WAVE METER

One of the most unusual radio instruments ever devised. Will perform any individual function of a complete receiver, and in addition may be used for calibrating, testing or checking. Makes a wonderful broadcast receiver, short wave receiver or transmitter. Oscillates violently over the entire scale range from 550 meters down to 20. Uses all tubes 199 to 210 and all voltages, AC, DC or rectified. Nothing like it ever placed on the market before.



The Radio Fan has at his disposal a device which will provide him with something to tinker with for an entire season without performing the same experiment twice. Become acquainted with all the circuits and the way tubes perform under particular conditions.

## SHORT WAVE SCREEN GRID PRE-AMPLIFIER

Experiment with the Multi-Unit connected ahead of your present short wave receiver or adapter. Bring in your real D.X. with more volume.

## AC BOOSTER AMPLIFIER

Similar to above but using the new type 226 AC filament tube. Increases range and flexibility of AC receiver and makes tuning more selective.

## SHORT WAVE ADAPTER

Connect to your battery operated receiver. Plugs in detector socket and makes hundreds of short wave stations instantly available. Uses any DC tube, preferably the one which you are now using as a detector.

## SHORT WAVE ADAPTION WITH AC RECEIVER

The most efficient AC Short Wave Adapter in the market. Two methods are described to attach this unit quickly and easily to your new AC set.

## SCREEN GRID R. F. AMPLIFIER

Convert your old battery-operated receiver into a modern set by the use of a type 222 DC, battery operated tube.

## SCREEN GRID R. F. AMPLIFIER FOR AC SETS

Increase the range of your up-to-date AC receiver by the introduction of an additional stage of high efficiency screen grid amplification. Uses 222 DC tube and a plate supply from your regular receiver.

## EXTRA STAGE TUNED R. F.

A booster to be hooked on ahead of the regular receiver. Uses any battery operated tube and will work on any receiver but a reflex.

## SINGLE TUBE RECEIVER

A good place to begin. Uses one 201-A tube or other DC type and by the use of headphones this set will pick up powerful stations from all parts of the country, both broadcast and short wave.

## AUDIO OSCILLATOR

laboratory measurements, short distance transmission and generating a beat frequency for super-heterodyne.

The Dealer and the service man requires this most valuable instrument for adjusting radio frequency circuits to resonance, providing a beat note or constant frequency oscillation for determining wave length of a particular condenser setting, calibrating a receiver, disposing of trade-ins and obsolete sets by making them up-to-date by the addition of a R. F. amplifier.

The Walker Multi-Unit comes in mahogany finish box with bakelite panel—7½ inches by 5 inches by 3¼ inches.

Price, complete..... List **\$16.00**

## Newark Electric Co. — Nothing But Radio

Special discounts to Dealers, Set Builders, Radio Service Men. Write for prices on all sets advertised in WCFL Radio Magazine—and all latest sets for 1929—complete accessories—and parts. Junior Hi-Q-29—Screen Grid Find-All 4—Screen Grid Converter—H.F.L. Remler—Silver-Marshall—Aero, Carter, National, Magnaformer, Utah Dynamic Speakers, Webster B., Travler Portable. You can save money and be sure of prompt, reliable service—just call in person or write at once.

## NEWARK ELECTRIC CO.

*"Nothing But Radio"*

226 WEST MADISON STREET  
CHICAGO, ILLINOIS.

TELEPHONE  
DEARBORN 0083

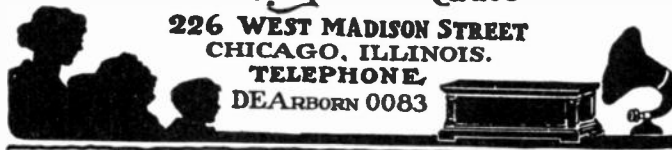

# WCFL Radio Magazine

*The Voice of Farmer-Labor*

OFFICIAL QUARTERLY PUBLICATION OF

WCFL RADIOPHONE BROADCAST STATION

*and the Co-operative Farmer-Labor Listeners' Association*

WCFL Radiophone Broadcast Station was established and is owned by Chicago Federation of Labor. In its maintenance and operation, Organized Farmers and Co-operatives participate with Union Labor through membership in Co-operative Farmer-Labor Radio Listeners' Association. WCFL Transmitter, located on the Navy Pier, Chicago, operates on a wavelength of 309.1 meters (970 kilocycles) by authority of the Federal Radio Commission. Studios and offices, 623 So. Wabash ave., Chicago. WCFL Radio Magazine is published by the Co-operative Farmer-Labor Radio Listeners' Association. Single copy, 35c. Annual subscription, \$1.25; foreign, \$2.00. Office of publication, 720 North Ridgeland avenue, Oak Park, Ill. Address all editorial communications to Editorial and Executive Offices, 623 So. Wabash ave., Chicago. Telephone Harrison 1182.

VOLUME 2

SPRING, 1929

NUMBER 2

## Station WCFL Forging to the Front

THE hearing before the Federal Radio commission on the application of Station WCFL for an exclusive wavelength and full time is now scheduled to begin on April 16. A reassignment from 970 to 770 kilocycles also is sought. A permit to build a 50,000-watt station at Downers Grove, Ill., was granted by the commission some time ago, and plans have been drawn for this new plant.

The docket assignment of WCFL's petition is due to two continuances. In the last issue of WCFL Radio Magazine the hearing was announced for January 15. Hardly had the magazine been placed in circulation than the hearing was postponed until February 6. Again elaborate preparations were made for presenting of WCFL's case, and once more the hearing was continued, this time to April 16.

Postponements were due to the fact that members of the Federal Radio commission were summoned before congressional committees, which committees spent considerable time during January and February considering pending radio legislation.

It now seems probable that WCFL's hearing will begin on the date set—April 16. At any rate Union Labor and Organized Farmers must be ready to present their case effectively on that date. Any other course is certain to be disastrous. Powerful and sinister forces are arrayed against the organized toilers. Friends of WCFL should hold themselves in readiness to attend the hearing and give testimony.

In the meantime WCFL is forging ahead, improving both its programs and increasing its facilities. Just recently an advantageous hookup has been made with the National Broadcasting

company whereby WCFL receives a number of very fine chain features. The inauguration of President Hoover on March 4 was the first N. B. C. feature broadcast by WCFL.

### ENLARGING SHORTWAVE BROADCASTING

Plans are being perfected for greatly enlarging WCFL's shortwave broadcasting. On February 15 the Federal Radio commission conducted a hearing on the application for an extension of WCFL's shortwave broadcasting on 37.24 meters. In addition to point-to-point telegraph communication with Buffalo, Cleveland, Columbus, Sheboygan, Detroit and Duluth on 37.24 meters and 1,950 meters, WCFL is seeking authority to establish similar communication with New York, Porto Rico, Mexico City and England. An option has been taken on a station at Bay City, L. I., that would give the desired Atlantic coast outlet. Organized workers in the foreign countries mentioned would help negotiate satisfactory connections there. Frequency maintenance equipment necessary to guard against interference with transmission on adjacent bands will be installed. Communication can be maintained with North American stations during daylight hours and with Europe during the night.

A subsidiary corporation to be known as the Federation Telegraph company will be created to handle the shortwave telegraph enterprise so that a general commercial telegraph business may be conducted.

Television broadcasts, discontinued on January 2, due to the expiration of the experimental permit, recently have been resumed, and are meeting with an appreciative response.

WCFL is forging to the front.

# Radio Controls *the* Nation

*Therefore Organized Labor Demands Equal Opportunity for Broadcasting Its Vital Message*

By FITZPATRICK and NOCKELS\*

*There are but 89 channels for broadcasting known as radio.*

*Forty are assigned to powerful stations as cleared channels.*

*Some 600 smaller stations must share the other 49 channels.*

*The Radio Trust has six or seven of the 40 cleared channels.*

*Through chain hook-up the Trust controls many other stations.*

*Organized Farmers and Union Labor have but one station—WCFL.*

*Station WCFL is not permitted to broadcast after 8 p. m.*

*Organized Workers are asking a cleared channel and full time.*

**R**ADIO broadcasting is the most effective means known to man for influencing public opinion.

When the President speaks over the radio, he is listened to intently by more people than read all the daily newspapers in the land. The mind cannot conceive of the influence radio is destined to exert upon the thinking, the habits, the character and the progress of mankind.

Radio takes its place alongside of the development of the printing press, and the establishment of the public school. It is the super-means of entertainment, education and propaganda. Whoever controls radio broadcasting in the years to come, will control the nation. For good or ill, radio will pour into the homes of the land, into the minds and hearts of the people, a constant stream of song and story, of history, science, economics, politics and propaganda. Overshadowing and outreaching all other means of communication, radio has become the unrivaled Master of Human Destiny.

Like the air we breathe or the sunlight that gives us life, radio must be charged with a public trust—the heritage of mankind. No man or corporation may appropriate it, any more than he could appropriate the air or the ocean. Granted that under our law a man may patent a mechanical invention and

limit its use; he cannot use his patented device in interstate commerce without the consent of the Congress of the United States. Radio, being a form of interstate communication, is therefore under the exclusive control of Congress.

A law has been enacted by Congress, creating the Federal Radio commission, and delegating to it the power and authority to license persons to operate radio broadcasting stations, when in the judgment of the commission it will be "in the public interest, necessity and convenience" so to do. By this law, the public welfare is the sole basis for determining who shall be allowed to operate a radio station.

## RANGE OF STATIONS

Under this authority, the Federal Radio commission has licensed some 650 broadcasting stations, although there are only 89 wavelengths or channels available for broadcasting in the United States. Forty of these channels are set apart as cleared channels; that is, only one station broadcasts on one of these channels at a time. In many instances, a single station is granted an exclusive channel; that is, it has the sole use of that channel 24 hours a day. Stations on cleared channels are allowed to use high power—up to 50,000 watts. These furnish fairly good service for a distance of about 500 miles; but they interfere with other stations in the same channel for 3,000 miles or more. The interference or "nuisance" range of any broadcasting station is about ten times its service range.

The great majority of the stations are limited to low power, and are placed on channels shared by several other stations, being so spaced geographically as to reduce interference to a minimum. They are merely local stations, with a dependable service radius of 10 to 100 miles. Occasionally, a station may be heard at great distances, but not with any regularity and such long distance reception is of little practical use.

Now let us see who has been granted licenses by the Federal Radio commission to exercise this precious franchise. Who have been deemed best qualified to serve the "public interest, necessity and convenience"?

First, there is a group of five great corporations which have formed an alliance by mutual contracts and "cross licenses" of patent rights to secure control of the whole field of radio patents and of the manufacture of radio equipment. This group controls, jointly, more than 2,000 radio patents. It has become commonly known as the Radio Trust. No one can make a radio receiving set, or operate a broadcasting station in the United States without having first purchased the privilege from some or

\*A copy of this statement of Labor's position on radio, signed by John Fitzpatrick, president, and Edward N. Nockels, secretary, of the Chicago Federation of Labor, was sent to each member of Congress under date of January 5. That it made a profound and favorable impression is shown by the attention it received. On Monday, January 7, Senator C. C. Dill of Washington read excerpts from the letter during a speech on radio. Favorable comments were also made by Senator McKellar of Tennessee and Senator Heflin of Alabama. After the discussion the entire letter was ordered printed in full in the Congressional Record.—Associate Editor.



all of this group. The Radio Trust is composed of:

General Electric company.

Westinghouse Electric and Manufacturing company.

American Telephone and Telegraph company.

United Fruit corporation, and

Radio Corporation of America, which is the pooling and selling agent for the other members.

Recently, the federal courts have held the Radio corporation guilty of monopolizing the sale of radio tubes, on which the patents had expired. The combined assets of this group exceed three billions of dollars.

These members of the Radio Trust have been licensed by the Federal Radio commission to operate the following stations:

#### GENERAL ELECTRIC COMPANY

Station KGO, at Oakland, California, with 10,000 watts power on a cleared channel, with unlimited time of operation: also

Station KOA, at Denver, with 12,500 watts power, cleared channel and unlimited time; also

Station WGY, at Schenectady, New York, with 50,000 watts power, for which it is now fighting in the courts for a *third cleared* exclusive channel, with unlimited time. (Later—G. E. has won its suit.)

#### WESTINGHOUSE E. & M. COMPANY:

Station KDKA at Pittsburgh, with 50,000 watts power, a cleared channel and unlimited time of operation; also

Station WBZ at East Springfield, Massachusetts, with 15,000 watts power, cleared channel and unlimited time of operation:

Station WBZA, at Boston, Massachusetts on the same channel; it also owns

Station KYW at Chicago, with 5,000 watts power on a cleared channel. This station it leases to the Chicago Herald Examiner.

In connection with Station KYW, it also owns Station KFKX, making in all, *five stations* owned by the Westinghouse company.

#### RADIO CORPORATION OF AMERICA:

Station WJZ, near New York City, with 30,000 watts power, a cleared channel and unlimited time of operation.

It also owns and operates Station WRC at Washington.

The three companies above named have formed and own the *National Broadcasting company*, which owns and operates Station WEA, near New York, with 50,000 watts power, a cleared channel and un-

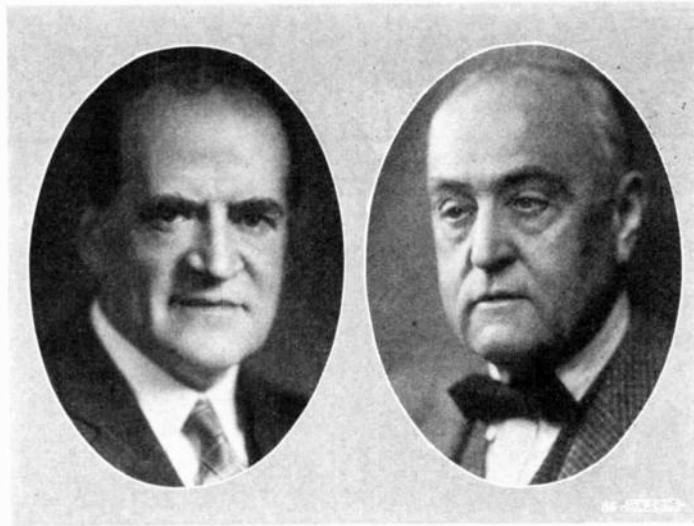

John Fitzpatrick, Pres.

Edward N. Nockels, Sec.

Chicago Federation of Labor

limited time of operation.

In short, the members of the Radio Trust own and operate some *eleven stations*, with an aggregate of about 220,000 watts of power, and are granted the *exclusive* use of six or seven out of the eighty-nine available channels in the United States!

By means of so-called chain hookups, the stations owned by the Radio Trust tie into their control some fifty or more of the leading radio broadcasting stations in the United States—practically all of those which have more than a local service range.

Other manufacturers of and dealers in radio supplies have been granted licenses for about sixty broadcasting stations. Some of these have cleared channels with a maximum of 50,000 watts power.

About twenty-five or thirty of the great metropolitan newspapers have been granted licenses to operate broadcasting stations on very choice wave channels. In Chicago alone, there are the following:

#### PAPERS GET BEST CHANNELS

Chicago Tribune company, Station WGN, with 25,000 watts power, cleared channel and unlimited time of operation:

Chicago Daily News, Station WMAQ, 5,000 watts power, cleared channel and unlimited time of operation:

Chicago Herald Examiner leases Station KYW from the Westinghouse company, 5,000 watts power, cleared channel.

Chicago Evening American, cooperates with Station WBBM, a station which has a cleared channel, 25,000 watts power, part time service.

Prairie Farmer owns and operates Station WLS, 50,000 watts power, cleared channel, but is required to divide time with the Insull Power Trust's station, WENR, also using 50,000 watts power.

Approximately three hundred and fifty licenses have been issued to various private business concerns, entirely local in character, many of them of trifling importance even in their own communities.

More than forty local churches have been granted broadcasting licenses. About seventy educational institutions, some mere local high schools, have been licensed. Thirty local chambers of commerce and similar organizations hold broadcasting licenses. The rest of the 650 or more broadcasting licenses have been granted to miscellaneous persons of no importance.

In view of the foregoing we have now to state an astounding and well nigh unbelievable fact:

Organized Labor, with some four millions of members, and comprising with

(Continued on page 56)

# Some WCFL Music Makers



Al Henke's WCFL Radio Frolics orchestra photographed just before starting on a performance. Al's jolly players are on the program each night to the delight of our radio listeners. Note the man-sized smile of the director as he is "shot."



Our little German Band snapped in action. These lads do know how to mix comedy with music in just the right proportions. They are not playing "Die Wacht am Rhine," but our old friend, "Lieber Augustien."

This is Mary Lynch. You have seen her before and hear her regularly. Her hornpipes and clogs feature the Farm Fiddlers' program of WCFL on Friday night. As a Tap Dancer Miss Lynch is actually there.

# How to Get Best Results from Your Light-Socket Radio

*Some Things to Do Before You Phone for  
the Service Man When the Receiver Howls*

By

J. H. WELCHES, *Gen. Mgr.*  
*High Frequency Laboratories*

**T**HERE has been a consistent demand from our readers for information pertaining to a.c. receivers—how to operate them,—how to reduce hum,—what about a.c. screen-grid tubes, and many other questions.

Well, in the first place, we will have to split the sets into two classes; three really would be better. First, straight a.c. factory-built sets using a.c. tubes throughout with the power supply unit built right on to the chassis. This takes in all such sets as Atwater-Kent, Radiola, Sparton, Freshman and many others of the same type.

In the second class we have factory or home built sets which operate with a.c. tubes and an external power supply device. Such a power supply is usually designed especially for the receiver with which it is used and the two really constitute a "light socket" set, corresponding to those in the first class.

Class three takes in all sets of either factory or home construction, which operate with d.c. tubes. They may be electrified by the use of a battery-charger combination and a B eliminator, or by an A eliminator and a B eliminator. The necessary C biasing voltages are usually obtained from the B eliminator.

We are mostly concerned with the second and third classes, as those sets in class one are usually of special design and there is not much that the buyer can do to alter them to advantage. The factory instructions which come with such sets are carefully worked out and when trouble develops it is best not to tamper with the set. They are usually sold with a year's servicing contract and one simply calls the dealer in case of trouble.

The most frequent trouble to spoil the operation of a good class one set is the failure of an a.c. tube. For a long time certain types of heater tubes had short, sweet, and expensive lives. However, they make them better now and there should be no need of a service man for at least six months, on this count.

Once in a while a transformer breaks down, a condenser blows out, or a connection goes bad, and again it is a job for a specialist on that particular kind of a set. Probably the best service available in large cities is realized by taking the set directly to the *distributor*.

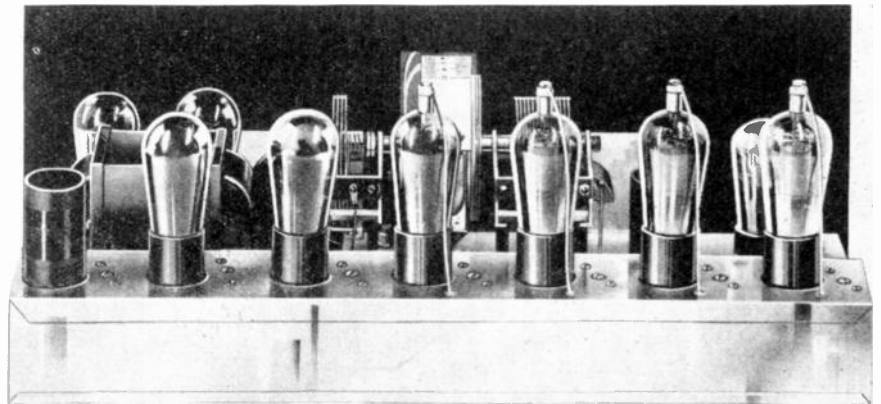

An H. F. L. Special Nine A. C. Chassis. A splendid example of the receivers described under Class Two in the accompanying article

His service department will fix the set in short order and the charge will be small.

The servicing of receivers in class two is handled in the same manner. However, very frequently the set and power unit of this type are purchased from one store, a cabinet from another store, and a speaker from some other source. Now, we have a good plot for a trouble scene. Each unit may be in perfect operating condition, but somehow they won't work with each other. In this respect they are almost human.

There are hundreds of reasons. For instance, is your power unit of the right type for your particular receiver chassis? Does your set terminate with a 112-A, 171-A, 210, or 250 tube and does it have an output transformer? The 112-A and 171-A tubes will operate a magnetic speaker nicely, if an output transformer or other coupling device is used.

These tubes will also operate directly into a magnetic speaker without an output transformer, but the tonal quality usually will not be so good. On the other hand, if a dynamic speaker is employed, there should be no output transformer since a special one is built right into the speaker.

The 210 and 250 tubes should feed directly into dynamic speakers, and magnetic units are not advised as they will break down unless specially designed for this work. In any case, whenever a magnetic speaker is used with these large power tubes, a coupling transformer should be used to protect the speaker windings.

Trouble is often encountered when the receiver, power unit, and speaker are mounted in the cabinet. The a.c. hum may be very strong (due to electro-magnetic coupling of the various units) and the speaker may roar due to vibration of the units and cabinet. These troubles are common to both class two and class three sets, so the same remedies apply. (Continued to page 53)

# Byrd Expedition Carries Unusually Diverse Radio Equipment

*Many Varieties of Variable Condensers Illustrate Varied Nature of Necessary Apparatus*

By BERT E. SMITH

ONE of the most outstanding things about Commander Byrd's latest venture, his Antarctic expedition, has been the way the man in the street in New York, Chicago, or any other American city, has been kept informed as to the doings and progress of the expedition. Day by day the columns of our great dailies devote much space to the chronicle of the day before with Commander Byrd and his little band of adventurers.



"City of New York" which carried first part of the expedition to Antarctic and served as temporary base

Locked in the ice floes thousands of miles away where no man has ever ventured before, they tell each other and the waiting world everything that happens, through the medium of radio.

## RADIO EQUIPMENT SPECIALLY BUILT

Never before, perhaps, has the value of radio as a daily burden bearer of news been so well exemplified, and also, perhaps, never before has so diverse an array of radio equipment been carried upon a single expedition.

Transmitters, ranging all the way from tiny battery supplied instruments, using tubes just like those in our receivers, to huge 1500-watt installations, are of every style and variety. Practically all of the equipment was built especially for or by members of the expedition, and each installment is suited directly for its own job.

Perhaps the best instance of the diverse character of the equipment is supplied by a brief look at the variable condensers used in the equipment. All of these variable condensers were supplied by the Allen D. Cardwell Manufacturing corporation of Brooklyn, whose product, due to its sturdy ruggedness and the patented features which reduce the electrical losses to the vanishing point, has been carried by every American polar or equatorial explorer who has taken radio, for nearly a decade.

More than a score of different types of variable condensers are included in Commander Byrd's equipment. Some of these

types were well known to the builder of radio sets a few years ago, before the present fad of complete kits had been built up, and when a set builder was educated to look for first class material in every particular. A dozen of the condensers used on the expedition are standard semi-straight line wave-length tuning condensers, identical to thousands behind the dials of radio sets still in use all over the country.

Due to the danger of sudden snow storms obliterating trails, and with them all signs of direction in the icy waste, every sledging party, no matter how short their journey or clearly in sight, will carry a portable crystal control transmitting set and

Recent thrilling rescues in polar regions have shown the vital importance of portable radio sets to stranded adventurers.

## CONDENSERS OF POPULAR DESIGN

In all of these small transmitters will be condensers exactly like those used by amateurs all over the world for many years. This particular type of condenser was designed seven years ago, and today its preference by the expert engineers who are entrusted with the task of selecting the expedition's equipment, stands as a tremendous tribute to the sound engineering and capable foresight which contributed to the design and construction of this particular type of instrument. As a matter

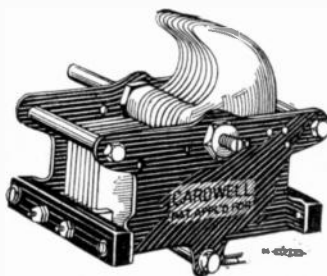

Semi-straight line wave-length tuning condenser

of fact, only one major variation in transmitting condenser construction has occurred since Cardwell introduced the low-loss principle. This improvement occurred three or four years ago, and the only change we find in its effects upon design are that the plates are somewhat heavier and have received a very high polish. This practically doubles the voltage or pressure of electricity which can be used in them. Such condensers are used in those of the expedition's transmitters which use tubes of fifty watts or more.

(The last stage audio amplifiers of most of the large "talking movie" features, utilize tubes of about fifty watt type.)

A bird's-eye view of Commander Byrd's base would show three tall masts towering high in the air, and from the antennas strung between them, lead-ins run to the huge transmitter which daily broadcasts news, letters, and personal greetings to parents and relatives here in the States. In this transmitter, as well as the stations upon the "Eleanor Bolling" and "The City of New York," we find one of the huge Cardwell high-power transmitting condensers, which are familiar to every engineer who has constructed or operated a broadcast station. More than a dozen of such condensers are to be found in the various transmitters which constitute the long- and short-wave broadcast equipment of Station WCFL. These huge monsters are bigger than many complete broadcast receivers, although they are so perfectly proportioned that in photographs it is almost impossible to tell them from the Cardwell condensers which might be used in a broadcast receiver. Massive plates, often one-half inch thick and eight or nine inches across, are polished until they resemble a mirror. Huge cast and pieces held together by three-quarter inch pillars constitute the frame. Great electrostatic shields keep the field of the electrodes out of the insulation and prevent the formation of strains in the insulation which would quickly burn it up. These insulation bars only come in contact with the live portions of the condenser where absolutely necessary, so that the leakage will be as small as possible. Even the nuts and washers which constitute the terminals are carefully rounded over and brought to a high degree of polish so that no possible point or pit can remain where energy can dissipate itself in the form of invisible corona. Like the smaller condensers, these giants are made with watch-like precision.

#### SPECIAL AEROPLANE EQUIPMENT

The aeroplane transmitters carry still further types of condensers designed especially for this use by experts who have specialized in the design of air craft radio equipment and like the other condensers, each is suited to a particular purpose.

In the receivers, both at the base and with the expeditions, will be found many of them, designed especially for the expedition's own equipment. Here, alone, do we find condensers which cannot be purchased from the regular manufacturer's stock, for each receiver has been carefully designed to cover a particular band or frequency at maximum efficiency, and

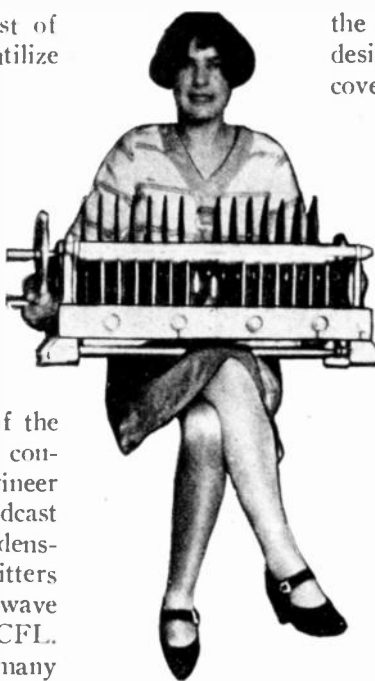

High-power transmitting condenser such as used by WCFL

the especially designed condensers are of such design and tuning characteristics that they will cover this band and no other.

All the other equipment in the radio sets of the expedition is similarly diverse, and like the condensers, each was selected with great care, for in the Antarctic there is no convenient way of ordering replacements by looking over a catalogue and sending a check or money order for the new part, nor is there any corner radio store. "A chain is no stronger than its weakest link," and a flaw in even the smallest part of the apparatus might severely cripple the complete radio set and imperil the lives of everyone in the party or cut the whole expedition apart from communication with the world for days or weeks.

The condensers make a good example of these, too, for a specially equipped machine shop and expert machinists are necessary to their production, and the Antarctic wastes afford no such facilities. Only master mechanics working under the direction of a master craftsman can be entrusted with the manufacturing apparatus on which the lives of brave men are apt to depend.

If you would like to know more about the special radio equipment carried by the Byrd expedition, or the type of condensers mentioned, this information may be procured merely by filling in one of the Business Reply Postal Cards on page 3. No postage is required.

### Speeding Up Communication

THE big telegraph companies, by the use of multiple telegraph apparatus, get six channels out of a single wire, sending six messages simultaneously over one wire. This speeds up telegraph service and reduces the plant expense in the maintenance of an excessive number of telegraph circuits. This equipment is also used on cables. Generally four channels are gained by this apparatus.

The Canadian Marconi company has recently perfected multiple transmission by wireless from a single transmitting station using the "beam" system for getting three perfect channels, two for wireless telegraphy and the third for telephoning between Canada and England. "Beam" stations use short waves and send waves in a rather straight line from the transmitting to the receiving station.

This system is being used largely by brokerage houses for international communication. "Beam" wireless will be used between larger cities by a newly organized wireless telegraph corporation which has been granted 56 short wave channels.

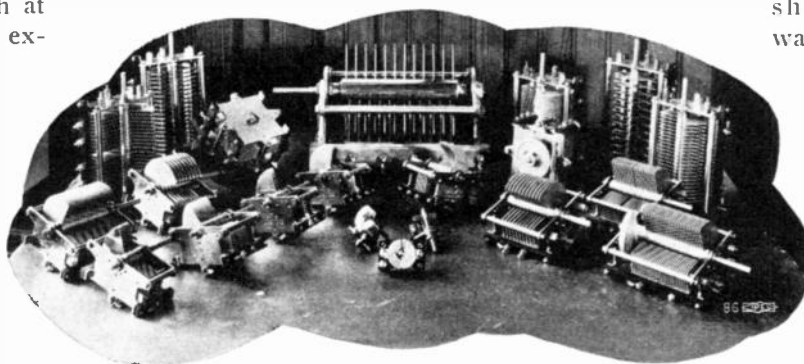

More than a score of different condensers were used in equipping the Byrd Antarctic expedition

# WCFL Is Back on the Air With Television Programs

By VIRGIL A. SCHOENBERG,  
*Chief Engineer, Station WCFL*

**A** GAIN WCFL is on the air with television, broadcasting daily except Sundays from 9 to 10 a. m. with most excellent results, after having been off since January 2nd, waiting the order of the Federal Radio commission to resume its work. Both movies and live subjects are included in our broadcasts.

We are proud to be able to report that the television development accomplished in the laboratories of WCFL is far in advance of that in other laboratories, both in type of apparatus and results obtained. The only other laboratory that has made any notable advance in this subject employs silhouettes showing such pictures as Krazy Kats, girls jumping ropes, etc., while the films employed by WCFL are standard motion picture films.

Since my return from Washington, where we gathered leading authorities on television and radio to present statements to the Federal Radio commission at its hearing on television, we have made considerable progress in improving definition of the movie film by television. It is my belief that future broadcasts will consist of sending out moving picture film.

## INDIRECT SYSTEM LIMITED

The indirect system of television, or the reflection method, does not offer very many possibilities commercially or in entertainment value. The work has to be done within certain limits, and the present developments permit only the successful televising of the head and shoulders of the subject.

The study of television is quite interesting, but it requires a comprehensive knowledge of radio, modulation, light, optics, amplification, photoelectricity, cells, mechanics and all of the known laws of physics.

With the successful broadcast of films, Labor can broadcast its stories visually as they are now being broadcast aurally. The successful development of the movies offers wonderful educational values, also it has immense commercial value. The Federal Radio commission is primarily interested in all things scientific, especially when they apply to anything of a vocational nature. The laboratory primarily functions to keep Labor informed and abreast of all scientific developments pertaining to radio and other electrical phenomena. I still hold that anything a man can visualize he can successfully accomplish, provided he is given sufficient time and suitable surroundings.

The recent interruption in the television broadcasts of WCFL is explained by the following statement, which was broadcast immediately after television was taken off the air.

"We have been in the past broadcasting television on this wavelength daily, with the exception of Sundays; also over our 500-watt experimental station 9XAA. We have made considerable progress in the development of television by means of these daily broadcasts, both, in the transmission of pictures and in their reception.

"We also have successfully demonstrated the feasibility of broadcasting moving picture film and its reception, and it is our hope and ambition to be able to give you a program of movies in the very near future. We are also experimenting in putting natural color in the pictures being broadcast. We have had a fair start and no doubt, as with all undertakings heretofore taken on by us, have proved a reality so that we may be able to give you colored television.

"Saturday, January 2, was the last day on our permit from the Federal Radio commission to broadcast television. This permit expired December 31, 1928, and we are now obliged to stand by with all of our equipment and await the sanction of the Commission as to when and where we will be able to again resume broadcasting television.

"If you listeners are interested in television and are desirous of having television broadcasting continue, I suggest that you voice your thought by either wire or letter to the Federal Radio commission or to Station WCFL.

"This order terminating television broadcasts not only affects WCFL but all other stations that are devoting time and money to develop it.

"Television offers some wonderful fields for development for the experimenter and also for the radio fan who desires to delve into a new field of radio.

## MUCH ROOM FOR IMPROVEMENT

"The equipment and method of reception can stand plenty of improvement. We who are familiar with this new art realize that, and are about to design and develop a type of television receiver that we think will answer the purpose satisfactorily.

"In order to have television, or radiovision, it was first necessary to be able to develop a system so as to be able to get a picture that was sufficiently satisfying before we could transmit. This required specially designed apparatus and amplifying equipment, accurately designed and constructed. Then the problem of putting what we had on the

*(Continued on page 43)*

# WCFL's Spacious Radio Studios



A peep into our large studio shows the Barton organ and two of the three pianos. The ous. Somewhat in the microphone is conspicu-background are French horns, saxophones, etc.



Access to the commodious studios of WCFL from other offices on the floor is convenient by way of the large foyer that runs almost the length of the building. This picture gives some idea of the comfortable appointments of the studios and their surroundings. White walls, massive columns, brilliant lamps, heavy linoleum floor coverings and comfy chairs.



Space and comfort characterize the lobby or waiting room adjacent to the studios. Four glass windows on two sides enable visitors to see the performers in action in their sound-proof cages.

Here's what is called our "Little Studio." Not so small at that. Between the pianos in front and to the rear the "mikes" stand upright and another may be seen on the announcer's table. Just lately this room has been redecorated. It's a wow.



*Edwin P. Reese  
is the author of  
this interesting  
resume of human  
weaknesses*



*Weird and super-  
stitious notions  
still beset believ-  
ing minds in this  
goodly land*

# On the Road to the Spirits' Abode

PERHAPS the most outstanding superstition that besets the sons of men is the one that we are no longer superstitious; that while once people believed in signs, portents and visions they are no longer that way; that such benighted notions have been trampled out by advancing civilization. The fact, however, seems to be quite the contrary. There are now more believers in magic, necromancy, astrology and divination than ever before. If they do not form so large a proportion of our population, it is because we have more people than ever before.

The average reader of newspapers easily concludes that our civilization is about on a par with that of ancient Assyria. Witchcraft reports take considerable space in print. Various superstitions are set forth in advertisements and other ways. Obviously pandering to wild beliefs is, if anything, more profitable than it was in the long ago. Modern efficiency methods have seen to that. One finds that astrology

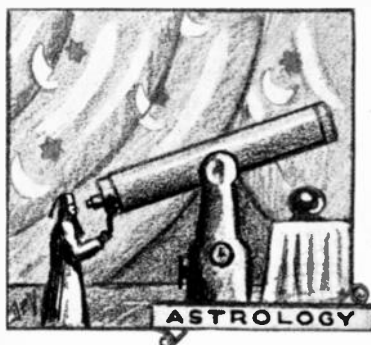

is more in vogue than astronomy, that our medicine is mostly magic and that the practice of necromancy, divination or other delusions upon believing peoples are esteemed professions. Amulets and charms are again in fashion. The ouija board rivals the typewriter in turn-

ing out popular literature. Palmistry is a flourishing practice. A mint of money has been made from people who believe that the disease, sex, religion and race of a distant patient could be determined by the electronic oscillations of a drop of ink or blood. Rain making, long one of the magic arts, is today a large and thriving business.

The average man who goes through life like a skittish horse shying at signs declares he is not

superstitious. No one can sell him on any philosopher's stone, elixir of life or fountain of everlasting youth in a thousand years. Ghosts and demons do not annoy him. His life is ruled by calm, practical reason—so he says.

But our spies report that he gets out of bed always on his right side and after his shower piously buckles on his magnetic belt; in seasoning his melon at breakfast he is in terror lest he upset the salt; he often sees money floating in his coffee; that when a half block from home and finds he has forgotten his pocketbook he never goes back after it; just as he kisses his wife goodbye he feels for his lucky dime—once he forgot it and he was stuck in an elevator for an hour and a half with seventeen red headed stenographers and on a hot day too. He will not tell a lie for luck as do thousands of merchants in foreign lands, but he drops a quarter into a cripple's hat to make sure that he (not the cripple) will thrive until night; if his first customer

is a colored person he glows at the thought of being favored by the gods of trade. By folding paper money lengthwise he reduces the chance of losing it in a bad venture. He knows people are talking about him because his ears ring. He shivers, and that tells him

that a 'possum has run over the spot that will one day be the resting place for his poor body after it has been recovered from the river. He knows he is to be drowned because he was born under the sign Aquarius. When he was nine years old he looked it up in a book. When he glances at his watch he carries the charm on the end of the chain. Lately he has read that it is a relic of medieval days when charms were charms, for

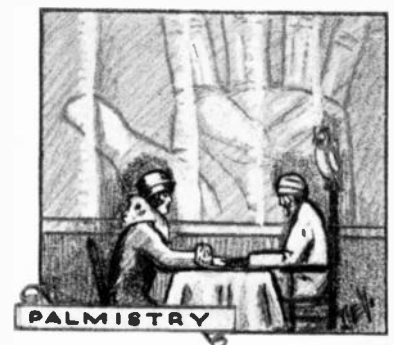

(Continued on page 54)



# Flashes of Radio Progress

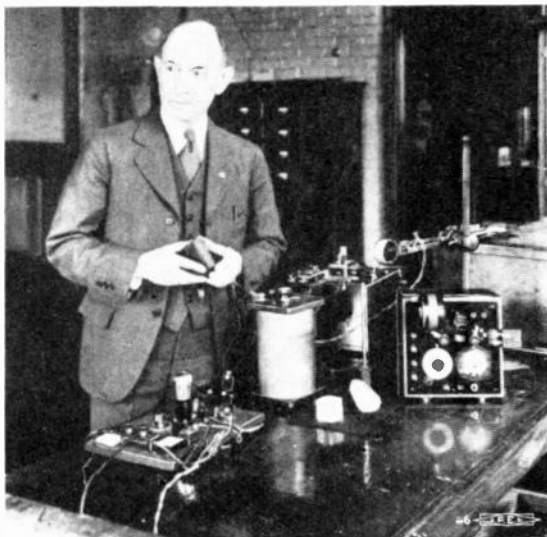

The prize for the year's outstanding feat in radio has been awarded to Dr. Walter G. Cady, head of the department of physics at Wesleyan University, Middletown, Conn. Dr. Cady was winner of the 1928 Morris Lienmann memorial prize. His investigations that resulted in this high honor were in the field of piezo-electrical phenomena.



Our boy friend is Maurice Poirier of Burbank, Calif., showing his model of a radio power plant that will rise 1,000 feet into the air and send and receive any wavelength. He hopes to direct radio controlled airplanes over long distances.



This little train does not talk but it acts humanly. Its movements are controlled entirely by sounds of the voice, stopping, backing and going forward at command. The secret lies in a one-two-three relay coupled to the microphone. W. W. Jones of the General Electric Co. is demonstrating the new toy.



Edward Dan Redington, 16-year-old student of Technical high school at Washington, D. C., photographed at his radio set with which he has exchanged messages with Commander Byrd in the south polar region. His call letter is WBKR.

---

# Some Broadcasts *by the* Editor

---

## At the Utility Stage

**T**HAT radio has reached the utility stage is indicated by the fact that radio is now standard equipment for modern flat buildings, just as are electric lights, telephone, steam heat and electric refrigeration.

The agent for a Chicago flat building now nearing completion is angling for future rent payers by advertising that his tenants need not have receiving sets in order to enjoy radio. In every room there is a convenient wall socket into which the loud-speaker can be plugged. Choice of programs offered by six stations is available. The flat dweller can flit from one to another of the stations merely by punching a button.

This new convenience is made possible by six radio sets centrally located, each permanently tuned with the designated station. Thus greater utility is made of radio equipment—and the flat owner avoids having his roof look like a cobweb.

Another flat builder is quickening the pace by announcing that the radio equipment in his building will afford choice of ten stations instead of six.

## Relief for the Color Blind

**M**ANY boys who have gone before some examining board preparatory to getting into railway work, have found out to their surprise that they had poor eyesight, could not distinguish between colors, at least with any reliable certainty. Being color blind, or color deficient, the railroad was not their place.

Matching colors is ticklish business for most any one. Take a sample to a store and one is dizzy before the almost endless varieties of navy blues and blacks or the subtle differences between tans and grays.

It will come as joyous news to these sufferers that the photo-electric cell can be made to look coldly and scientifically at a color and then peg it down to a certain number. The accuracy of this electric eye, far greater than that of the human eye, can be depended upon to settle any dispute as to whether two things match.

Color measuring devices are not exactly new, but the photo-electric cell represents a sharp advance for practical use.

After one glance at a brilliantly lacquered automobile body, the electric eye will analyze the color, compute the number by which it may be specified, so that wheels for the car may be made in a factory miles away and turned out to be a perfect match when the whole is assembled. Hoods are often made in one plant and bodies in another and the new device makes a simple thing of securing harmony.

The troubled lady, who so much loves to buy her frocks in Paris but prefers American shoes, can call on the new color instrument to give her the key number for purchasing all of the accessories for her costume.

Just how much good the new "eye" will do people actually color blind is problematical. Likely the enthusiastic and alcoholized automobile driver will continue to crash against red lights mistaking them for green but at any rate there will be no excuse for any man coming away from a sale with six purple neckties.

## Court Jolts Radio Authority

**T**HE dignity of the Federal Radio commission seems to have suffered a severe bump in the recent decision of the Court of Appeals of the District of Columbia in the celebrated WGY case. The court holds that it is all right for the commission to regulate radio but the job should be done in a reasonable way. WGY must be allowed to operate as long as it pleases. That jars the commission's absolute sway, and broadcasters who formerly trembled every time the commission barked are now impudently thumbing their noses at the radio regulators.

The notion that priority and power establish for a station property rights on the air was also mussed up considerably by the same decision. The court holds that WGY has no property rights but must get along with an ordinary license, even though it can operate full time. Thus the decision is a sort of 50-50 proposition for the station.

WGY, located at Schenectady, N. Y., is one of the oldest and best known stations on the air. It is licensed to operate on 790 meters with 50,000 watts power. The station is owned by the General Electric company, also owners of Station KGO at Oakland, Cal., operating on the same wave length.

The radio reallocation of November 11 required Station WGY to cease broadcasting at a time corresponding with sundown on the Pacific coast, so as not to interfere with the western station.

The General Electric company appealed to the federal court for relief. The court's decision holds that the order against WGY broadcasting at night is unreasonable and would deprive many radio fans of a service to which they are accustomed and are entitled. Regarding the matter of interference the court says that the annoyance caused to some remote radio listeners by the simultaneous broadcasting of the New York and California stations is outweighed by the benefit to hundreds of thousands of radio fans living within a few hundred miles of Schenectady.

As a result of the decision it seems probable that several large stations in the eastern part of the United States that have been denied cleared channels may do like WGY did—use such time as they want and go to court for legal sanction. Some fear that a general breakdown of the authority of the commission may result. However, the decision as rendered applies only to WGY.

In the matter of property rights, the court holds

that priority, heavy investment and long and efficient service have not created for WGY property rights on the air. Here again, though, the decision is not held to be sweeping and general but merely specific. However, it is a hopeful indication. It augurs well for maintenance of freedom of the air.

---

## For Your Convenience

WITH this issue WCFL Radio Magazine inaugurates a new and a distinctive service for your benefit. You can now answer advertisements appearing in WCFL Radio Magazine, or request information on any subject, without going to the bother of procuring stationery and buying stamps. You can write to us without cost and almost without effort. This is made possible by the Business Reply Postal Cards appearing on page three of this issue. Just merely detach one of the cards, inscribe your message or check the subjects in which you are interested, sign your name and address and deposit the card in the nearest mail box. No stamp is needed. What could be handier?

The Business Reply Postal Cards are a comparatively new feature of the postal service. However, cards of this kind have been used extensively by business firms doing a great deal of circularizing, but never before has a magazine printed these cards in its regular issue, so that its readers could use them as they perused its pages. WCFL Radio Magazine claims the distinction of being the first magazine to adapt the Business Reply Postal Card idea to the convenience of its readers. We trust you will make fullest possible use of this convenience.

One of our good friends says that the cards make exceptionally handy bookmarks. He suggests that you tear out one of the cards when you start to read the magazine, carrying it along from page to page in regular bookmark fashion, checking on it the subjects in which you are interested. When you have finished reading the card is ready to mail. Try it.

---

## Concerning Unemployment

THE laborer, who is inclined to regard the inventor as his natural enemy, reads with considerable fear and trembling reports of new devices to do away with hard work and displace toilers. Lately the printer has been pondering the news about the invention of the teletypesetter, which looks to the making of the linotype operator's job practically a thing of the past. It is a demonstrated fact that a single typist in one city may put into automatic and simultaneous operation a thousand linotype machines setting type as perfectly as if operated by human hands.

The way the business is done is by using an electric typewriter which perforates a ticker type, each group of perforations corresponding to a letter or numeral. The code on the tape is then flashed electrically into a newspaper office many miles away and a tape in the latter office is similarly perforated. The second tape is then put through a machine attached to the linotype machine, and electrical impulses translate the code into depressions of the keys of the typesetting machine. The ticker tape takes the place of the human operator.

How seriously this contrivance is going to affect the

labor market in printing, is rather doubtful, if one may judge by all that has followed since labor-saving machinery began to improve processes originated by Gutenberg. One thing seems to be sure and that is that the teletypesetter is a far-reaching step in the industry.

The argument that labor-saving machinery and mass production are chiefly responsible for our industrial woes is no more convincing than that such ills exist because of lack of currency, low tariffs or Wall Street.

A more plausible explanation of the present scarcity of jobs is likely to be found in the post-war practice of our citizenry in putting money into stocks, bonds, land, insurance, electricity and education, rather than into manufactured and agricultural goods. There seems to be no lack of money in certain quarters, and no end of spending; this in spite of the estimate that since 1920, there has been a decrease of 1,800,000 employes in farming, manufacturing, mining and railroading. Deducting for the expansion in building and repair lines, reliable authorities place the net drop in employment from 1923 to 1928 at between 500,000 and 1,000,000.

The average man is mainly interested not in speculative theories but in any program of public and private enterprise that will set men in the breadline to work. Anything that will add to the buying power of the people as a whole is to be encouraged as sound policy.

---

## Revised Radio Log Available

SEVERAL thousand copies of the latest revision of Haynes' Radio Log have been received at our office and are awaiting distribution to readers of WCFL Radio Magazine. The log is printed on a fine quality of flexible cardboard in handy size. It is yours for the asking.

For the busy radio fan Haynes' Radio Log is a great convenience. It shows at a glance the relative position of the various stations, giving the assignment of each station in meters, kilocycles and power. By logging a few of the larger stations, you can easily locate and identify more distant stations on adjacent wavelengths.

Haynes' Radio Log formerly was printed in each issue of WCFL Radio Magazine. However, it is not always convenient to have the magazine close at hand when trying to bring in or identify distant radio stations, and the paper on which the magazine is printed is not well adapted for recording in ink or heavy pencil the loggings of various stations. We are sure that all our readers will agree the new form in which we are supplying their favorite radio log is much handier.

Fill out and mail one of the Business Reply Postal Cards on page three and a copy of this latest revision of Haynes' Radio Log will be mailed to you free of cost. This is our means of distributing the logs only to such of our readers as desire them. Send for yours today.

---

## WCFL Now on National Chain

NEGOTIATIONS have been completed whereby Station WCFL receives broadcasts from the National Broadcasting company. This will add many interesting features to the WCFL programs. The first N. B. C. feature to be handled by WCFL was the broadcast of Pres. Hoover's inauguration. More about our new hook-up will be reported in our next issue.

# Equality in Radio Opportunity Is All That Labor Seeks

*If Capital Has Exclusive Channels  
Then Toilers Demand at Least One*

By HOPE THOMPSON\*

THE Radio Act of 1927 evidently contemplated that the Federal Radio commission could, within the first year of its existence, complete the substantial part of its duties as enumerated in Section 4 of the Act. On that assumption, the Act provided that the greater portion of the power and authority of the commission should, at the end of the first year, be vested in the Secretary of Commerce. Presumably, Congress believed the administration of the Act, after the first year, would be largely a routine matter which could readily be taken care of as a subordinate part of the duties of the Secretary of Commerce.

Before the first year had expired, it was apparent that the work of the commission was so incomplete that Congress extended the previous authority for another year.

It is now proposed to extend this authority for yet another year.

We believe this should be done, provided the personnel of the commission shall be so changed as to assure an administration of the law in accordance with its true intent.

It is evident to all who are familiar with radio that the task originally assigned to the Federal Radio commission is far more difficult, intricate and important than it was assumed to be two years ago. The work of the commission seems to be increasing and unfolding as the art and the industry develop. Instead of having completed the major duties vested in it by the Act, the commission is daily confronted with new problems, new controversies, old problems unsolved, old controversies unending, and perhaps an occasional criticism.

## TASKS CONFRONTING COMMISSION

Like Sisyphus, the commission is doomed to a perpetual struggle to roll the stone up the hill, but never to reach the top.

We believe that, at the proper time, but not now, Congress should create a permanent commission in charge of wireless and possibly wired communications. In the meantime, it is of urgent importance that the Federal Radio commission continue to function without interruption, confusion or delay.

We appreciate the extraordinary difficulties and

problems that have confronted the commission, and the magnitude of the work it has had to do. We have no desire to indulge in fruitless criticism. Rather, in the hope of making a small contribution to the usefulness and efficiency of the commission, we call attention to the following matters which we think it can, and we hope it will do, if granted another year of its present authority:

1. A substantial amount of engineering tests and surveys are necessary in order that the commission may have accurate information regarding radio interference, efficiency in the use of channels and frequencies, the relative advantages of high and low power, the utilization of short-wave frequencies, and many similar matters. The law cannot be efficiently administered by anybody until a vast amount of accurate scientific data has been assembled.

## PROCEEDINGS OF JUDICIAL NATURE

Proceedings before the commission are quasi-judicial. A hearing on an application for license usually involves two or more contestants, with witnesses, lawyers, decision and appeal. For practical purposes, such a hearing is substantially equivalent to a hearing in court, with five judges on the bench. The issue involved may be of very great value to the litigants. If an appeal is taken, it must be on the record and evidence taken at the hearing. In view of all this, it would seem highly improper for a commissioner to permit one of the litigants to confer with him privately in regard to the controversy, to urge his claims, and possibly to prevent matters which are no part of the record or evidence in the case. So long as this custom continues, decisions will be subject to suspicion.

3. A study of the present allocation of broadcasting facilities, coupled with our own experience, convinces us that the commission has been influenced by matters not in the record. It cannot be otherwise if the commissioners visit, or are visited by applicants or persons on their behalf, listen to their statements and persuasive arguments, and give consideration to privately acquired information or secret complaints. It is our belief that the commission should set up a system of procedure which will reduce to a minimum the attempts privately to influence its action, and which will insure that all decisions of the commission are based solely on the law and the evidence of record in each case.

4. The Radio Act provides for five commissioners,

\*This statement was presented by Attorney Hope Thompson of Chicago, representing the American Federation of Labor and Broadcasting Station WCFL, before the radio hearings of the Merchant Marine and Fisheries committee of the House of Representatives in Washington on Monday, January 14, 1929.

one to be chosen from each zone. But the duties and authority granted are granted to the commission as a body. Certainly it was not the purpose of Congress to authorize or permit the procedure now in practice, whereby each commissioner takes practically exclusive charge of radio affairs in his zone. This practice should be abandoned, and a proper procedure set up by the commission in order that the spirit and purpose of the law may be carried out.

5. In allocating channels, power and time of operation to broadcasters, we think the commission has failed properly to apply the sole test provided by the Radio Act, viz., "the public interest, necessity and convenience."

Many exclusive, cleared channels, with high power and unlimited time of operation, have been granted to great corporations and metropolitan newspapers. In fact, nearly all desirable channels have been so parcelled out, leaving the proverbial "chips and whetstones" for the rest of the country.

#### BIG BUSINESS GETS BEST CHANNELS

General Electric company, Westinghouse Electric and Manufacturing company, and Radio Corporation of America, own some eleven stations with aggregate power of about 220,000 watts, and have been granted seven cleared channels. These three great corporations already have a strangle-hold on the radio industry by reason of some 2,000 patents which they have cross-licensed to each other. Whether or not they are violating the anti-trust laws, as some allege, it seems too evident for argument that it is not in the "public interest, necessity and convenience" to hand over to them so large a portion of the limited broadcasting facilities, while denying any adequate facility to other applicants, some of whom represent reputable and substantial citizens in very large groups.

Westinghouse company own five stations, all in the National Broadcasting chain, on cleared channels, and three of them with high power. In fact, it has so many it leases KYW to the Chicago Herald-Examiner. This is a 5,000-watt station, located in the heart of Chicago in violation of the rules of the commission, and over our protest. It blankets our station WCFL, which has 1,500 watts power. Another Westinghouse station, KDKA at Pittsburg, with 5,000 watts power on a cleared channel adjacent to WCFL, causes a great deal of interference with our programs.

#### CHAINS CONTROL BEST STATIONS

Other illustrations might be cited of what appears to us to be a misapplication of the test of public interest, necessity and conveniences, as for instance, the granting of so many exclusive channels with high power to influential metropolitan newspapers; the consideration amounting, as we think, to favoritism, shown for chain stations, of which there are now 108 stations in 78 cities in the N. B. C. and Columbia chains. In Chicago, eight high-powered, cleared-channel stations are in these chain systems. All of these chain programs come out of New York. All of these stations, or practically all, are operating for profit, either directly or indirectly. There are

## Should New York City Dominate the Nation?

**WE BELIEVE** the certain tendency of high power, cleared channels and chain hook-ups is to centralize and monopolize radio; that the ultimate result will be to eliminate the smaller stations, to force all the rest into chains and central control, and so to place in the hands of a few great corporations the power to select the entertainment, choose the speakers, and determine the kind of messages that shall flow daily into the homes of the land. The power to do this insures the power to dominate the thoughts, habits and culture of the nation.

Granted that their musical programs are superb, that their talent is the best in the world, that at the present time there is no harmful propaganda; still, is it in the "public interest, necessity and convenience" for all the people of this nation to be dependent for their radio programs on the City of New York and on a few great corporations? And for those corporations to control this marvelous new means of communication?

Quite likely the great majority of radio listeners prefer the chain programs. They care little who sings the song or tells the story. They have little information about it, except that it gives them pleasure. They have no true appreciation of its power to direct the thinking, the habits and the culture of the nation. They have no vision of the place radio will occupy in the coming years. Their interests and the interests of posterity must be guarded by those of you who have been "set as watchmen on the walls."

Organized Labor of America is blowing the ram's horn.—*Hope Thompson in letter to congressional committee considering radio legislation.*

many stations in the country which are not operating for commercial profit; but they have practically all been restricted to very limited facilities.

With full appreciation of the statement published by the commission on August 23, 1928 (F.R.C. Report, page 166) on this subject, it is our opinion that the commission has gone far astray in interpreting this crucial "public interest" clause in the status, and even farther astray in working out its proper application in the granting of licenses.

#### RADIO'S POWER UNEQUALLED

We believe this subject should receive a much broader consideration than has yet been apparent. We regard radio broadcasting as the most effective means known to man for influencing public opinion, for instruction and education, as well as for entertainment. We believe it is destined to produce far-reaching results in the thinking, the habits, the culture and the general welfare of our entire population. If this be true, then it follows that grave and serious consideration must be given to the sources from which radio programs emanate; the probable future sources and control of such programs, the probable effect they will have on the character and habits of the people; the diversity of programs generally, whether or not they give adequate opportunity of expression to, and supply the needs of all the various fields of interest within the nation, and many similar considerations.

(Continued on page 58)

---

# Senators Support WCFL's Plea

---

THE sincere appreciation manifest by prominent members of Congress for the right of the "Voice of Farmer-Labor" to an adequate place on the air is one of the most encouraging developments in the fight now being waged by friends of Station WCFL. Support of the most valiant kind has come from all quarters. This demonstrates that our cause is a righteous one and our contention only fair and reasonable. In fact, many of the members of Congress who have voiced sentiment freely in support of the petition of WCFL have commented specially upon the justice and reasonableness of our petition. Others have expressed appreciation of the frank and full presentation of the radio situation and its relation to public welfare made in letters and briefs sent to members of Congress by the Chicago Federation of Labor.

The following excerpt from the proceedings of the Senate on Monday, January 7, is an interesting indication to the attitude of members of Congress toward the petition of WCFL:

Mr. DILL. "Mr. President, I have a letter from the manager of the WCFL Radio Magazine, of Chicago, Ill., setting forth the claims of the labor-union station for larger power and for a clear channel for radio purposes. I do not care to read all the letter, but I do want to read certain parts of it which discuss the place that radio holds as a great resource of the American people:

"This is the last great public domain. A few squatters have set up their tents, turned a few furrows, and now ask the Nation to confirm in them title to a continent. What do they care for the "public interest, necessity, and convenience"? What they want is to make money, to acquire power and to control in their interest this unparalleled new means of communication.

"Never in our history has there been such a bold and brazen attempt to seize control of the means of communication and to dominate public opinion as is now going on in the field of radio broadcasting. And never in our history has the Federal Government shown such a crass disregard and contempt for the rights of those who toil.

"This is a battle of the giants. On the one hand stands organized capital seeking to grasp and monopolize for itself, for commercial profit and for propaganda in its own interest, this vast and immeasurably valuable means of communication. On the other hand stands organized labor, armed with right and justice, battling for some measure of freedom of speech and freedom of the air, and for the right to have 1 out of the 89 broadcasting channels left open for the dissemination of the principles, policies, and ideals for which organized labor stands. It seeks no profit; it wants no commercial gain, but it does want an opportunity to serve the workingman of the country, and through them, the Nation."

"Then, this letter goes on to discuss in a remarkable manner what constitutes public interest that I want to read another portion of it."

Senator Dill then read more of the letter, printed in full on page 8 and 9 of this issue. Continuing, he said:

"I may say that in the allocation of radio stations

made by the commission in November this one labor station was allowed 1,500 watts of power and was permitted to broadcast on a wave length during the daylight period, but forbidden to broadcast after the sun went down on the Pacific coast. In other words, the labor station, designed to serve and reach the laboring people in the central part of the United States was not allowed to broadcast during the nighttime, the only time when the great masses of the laboring people can listen to the programs.

"They have appealed for a full, clear channel. They appealed for 50,000 watts of power. I am informed this morning that in the last two or three days the commission has granted a permit to this station to build a 50,000-watt power station, but has not granted it the right to rebroadcast on a short wave length, in order that it may be set up little stations throughout the country on the same wave length and reach all sections of the United States.

"This particular letter makes an appeal that they may be allowed to broadcast their programs all over the country, not hogging a great lot of channels in the air, but by using a short wave length to rebroadcast their programs to stations of small power located in small towns, which will reproduce the programs on the same wave length that the Chicago station is using, and thus their chain programs will be on the same wave length in every part of the United States.

"It seems to me that when any radio organization offering entertainment and information to the people proposes to do it by serving the whole country on one channel when there is such a shortage of channels, the Radio Commission should encourage that station to go ahead and demonstrate what can be done."

Mr. McKELLAR. "Mr. President, will the Senator yield?"

Mr. DILL. "I yield to the Senator from Tennessee."

Mr. McKELLAR. "I have read the very remarkable letter to which the Senator calls attention. It is a very strong and able letter, and I am glad the Senator is going to put it in the RECORD. I think every Senator should read the letter. However, what I want to ask the Senator is this: What reason has been advanced by the Radio Commission why this station should not be granted the right, in a substantial way, at any rate, that it seeks?"

Mr. DILL. "I am unable to answer the Senator's question, because I was not present when the refusal was made. I do know, however, that the objection is made to their broadcasting after sundown that it would interfere with a station, KJR, in Seattle, on the Pacific coast, that has 5,000 watts, while this little station has 1,500 watts. In the first place, the interference would be so small that nine-tenths of the country would not know

(Continued on page 30)

# The New Hammarlund-Roberts All-Electric Jr. Hi-Q 29

By

LESLIE G. BILES

IT is freely admitted that the three major requirements for an up-to-the-minute radio receiver are selectivity, sensitivity and quality of reproduction. These three factors are very closely tied with the design of the circuit and it is for this reason that only those receivers that have the highest type of design possess these three vital features.

For the past few years a series of receivers have been offered to the set builders bearing the name Hi-Q. These sets have shown yearly many improvements and the Junior A.C. model herein described carries in its makeup the three necessary factors mentioned above.

Before going into the theory of this receiver, let us consider for a moment something that has made this modern set possible. This is the new A.C. screen-grid vacuum tube.

Two of these tubes are used in the two stages of radio-frequency amplification. The screen-grid coupling tube in the antenna circuit is used to isolate the antenna from the first tuned circuit, thus giving efficient simultaneous control of both the tuned radio-frequency stages and the detector, without the necessity of compensating for different types of antennae. In the Junior Hi-Q 29 the use of screen-grid tubes not only gives complete isolation, but, due to the high amplification factor of the tube, gives a considerable increase in signal strength as well.

The amplification gained through the use of the screen-grid tube in the second stage is very high.

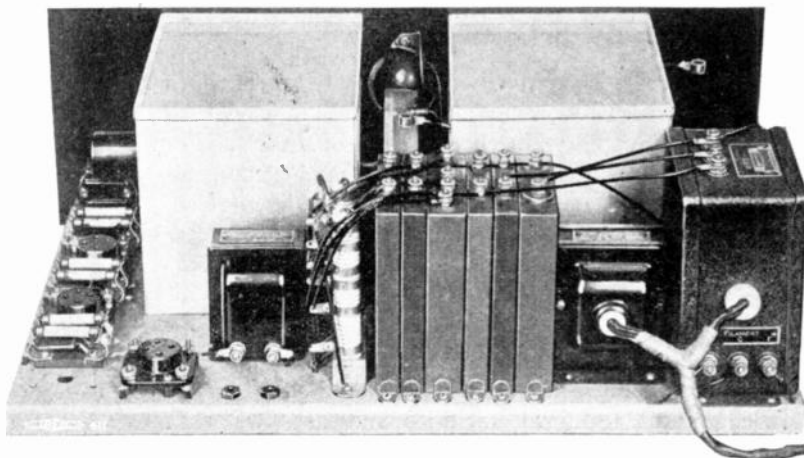

The Junior Hi-Q 29 Is Thoroughly Shielded

But here another factor of design enters; the radio-frequency transformers must have primaries especially designed for use with these tubes. These R. F. Transformers tend to equal amplification over the entire broadcast waveband. In order to adapt the receiver to every possible local condition, the primaries of these radio-frequency transformers are tapped, so that the operating characteristics of the set can be varied for the different degrees of selectivity required.

The detector circuit has been designed for "plate rectification." This we know insures a very high quality output for the three stages of resistance-coupled amplification. The advantages of this type of a.f. amplification are too well-known to need further comment here. The mechanical layout particularly fits the requirements of the Junior Hi-Q. A hi-mu tube is used in the first stage, a 201-A in the second, and in the last, a 171-A or other power tube, depending on the amount of power desired for the loud speaker.

In order to prevent electrostatic and inductive coupling between the tuning circuits, they are completely shielded in aluminum cans of special design. If screen-grid tubes are to be used anywhere near their maximum efficiency, all sources of feedback must be eliminated. The separate stage shields effect the necessary isolation. In addition to this, the screen-grid terminals of the tubes are by-passed to prevent coupling. It will also be noticed that separate filters are used in the plate circuits of both screen-grid tubes, these filters consisting of 0.5 mfd. condensers and 5000-ohm resistors.

The shielding of the screen-grid tubes has been handled in an unusual manner. Placing these tubes in the shield cans with the coils and tuning condensers would (Continued on page 47)

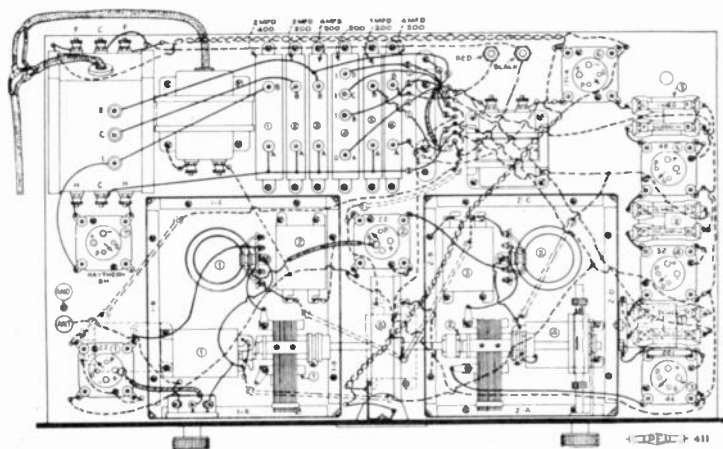

Schematic Diagram of Junior Hi-Q 29

# Solving Television's Problems

*Amazing Rapidity Required to Transmit Pictures  
With Fair Detail—Reception Is Simpler Matter*

By D. E. REPLOGLE\*

TELEVISION is a most complicated branch of engineering, involving an intimate knowledge of radio, electricity, mechanics, gaseous conduction, distortionless amplification, modulation and demodulation, photography, optics and even a new stage technique. We have much to learn of all these.

Once we have mastered the technique of television transmission, there should be no dearth of subjects. All the world is our stage, and we may draw upon it as we will. For the present, we must content ourselves with simple shadowgraphs or silhouettes; later, as our knowledge and technical facilities increase, we shall perhaps stage playlets; and ultimately we shall televise speakers and artists before the broadcast microphone, leaving the aural accompaniment entirely at the option of our audiences. After all, the television presentation is a fleeting and instantaneous thing, best suited by long odds to portraying a given subject at a given instant of time. But, before we concern ourselves with the pictorial nature of our television images, we must first solve the problems attendant upon their propagation and reception.

## HOW PICTURES ARE TRANSMITTED

At the transmitting end, we simply break up our subject into a number of parallel and overlapping lines by means of the familiar scanning disc—a circular plate with *eccentrically* placed holes. A photo-electric, or light-sensitive cell converts the varying intensity of these lines into varying electrical impulses. These are amplified in the conventional manner and impressed on the outgoing waves of a broadcast transmitter. At the receiving end, the signals are further amplified and fed to a neon glow tube or kino lamp—a sensitive device whose luminosity varies with the modulation of the incoming wave. Our problem is to reconvert this luminosity into lines whose gradations are similar to those obtained at the transmitting end. For this purpose we employ a scanning disc which must be revolved in perfect step with the one at the transmitting end. The holes in the disc break up the glowing plate of the kino-lamp into a series of lines of varying intensity. At any given instant, however, there is just a single dot of light on the television screen, and its brilliancy or dullness is a function of the modulation of the incoming radio wave at that particular instant. The speed of these successive dots is such that in 1/15th of a second, they seem to form lines which in turn unite to weave an entire animated image. It is therefore obvious that television is basically an optical illusion which depends upon the persistence of human vision and upon the slowness of the eye to assimilate ultra-rapid changes of scene.

We thus see that the television image, like the news-

paper half-tone engraving, is simply a pattern of closely-woven, successive lines. The problem therefore resolves itself into questions of how many lines we are using, how much contrast we have between the maximum and minimum intensity, how accurately our lines meet or overlap, and how well we are able to maintain synchronism between two scanning discs. There is, however, a great difference between the half-tone engraving and the television image. Crude in detail as the former is, it contains 65 vertical and horizontal rows to the square inch, or a total of 4,225 dots. Now, in order to weave an even cruder television image, let us say of 50-line texture or corresponding to 2,500 dots to the square inch, we have to transmit its lines in less than 1/16th of a second, or at the stupendous rate of 40,000 dot elements per second.

Referring again to the newspaper half-tone, let us call attention to the fact that a minimum image of about 3x5 inches is required for viewing persons and events intelligibly. To achieve this in television practice, even with a 50-line texture, we would have to build up an image 150 lines high and 250 lines wide, a feat which would compel us to transmit the equivalent of 37,500 dots elements in 1/16th of a second. For the present, we have accepted the 100-line image as standard technique, inasmuch as it can be transmitted within an 80-kilocycle wave band and permits of a reasonable amount of detail. Even, however, with a 100-kilocycle wave band, we may not hope to attain anything like the crystal-clear detail of the present-day motion picture. It must now be obvious that the systems employing 24-line images which may be crowded into a wave band of four or five kilocycles, are wholly inconsistent with a serious television service.

## LUMINOSITY IMPROVEMENT NEEDED

We now come to a consideration of our second major problem, which is that of luminosity. We have accomplished wonders with present neon tubes with their low candle-power, but there is still room for a world of improvement. It seems highly probable that we shall have to develop a lamp which, while retaining the delicate sensitivity of the neon tube, is capable of vastly greater illumination. Further, we must work out more efficient methods for utilizing and conserving the limited amount of light at our disposal. Considerable progress has already been made along these lines by C. Francis Jenkins of Washington, D. C., who has developed a multiple target neon lamp and an ingenious scanning drum which utilizes light-conducting quartz rods. Mr. Jenkins, E. F. W. Alexanderson and others have developed scanning discs with matched lenses which permit us to make a more efficient use of the light source. The matched lens scanning disc requires an exceptionally powerful neon spot light but so much progress has already been

\*Engineering staff Raytheon Manufacturing company.





Mitzi, star of the *Lovely Lady* musical comedy cast, seated before the battery of photo-electric cells of the WCFL television equipment.

made by both American and European experimenters in this field that we may consider the problem well on the way of a satisfactory solution.

Our third major problem is that of synchronization. If television were to be limited to metropolitan areas where the same alternating current systems are available, it would be a relatively simple matter to keep the two scanning discs in step by means of synchronous motors. Television, however, will doubtless extend to territories in which the same current is not universally available and we must therefore develop some independent means of achieving our end. Already, ingenious speed controls with centrifugal governors making and breaking contacts across speed-control resistances, have been developed. Another ingenious device is a gear arrangement which permits adjustment of the phase relation between a synchronous motor and the position of the disc when it is in motion. Under this arrangement, a synchronous motor can be used to drive the transmitting mechanism, and the scanning disc at the receiving end can be controlled so that it can compensate for the difference in phase between transmitter and receiver.

It seems highly probable, however, that the ultimate solution of the problem of synchronization will be found in the use of ingenious breaking devices which will regulate the scanning disc by means of a definite frequency impressed on the television carrier wave along with the signals themselves. Or perhaps there will be a synchronization signal which will be sent out for each revolution of the scanning disc at the transmitting end, and which will tend to start out the scanning disc at the receiving end in step with the transmitting disc at each revolution.

These, however, are just possibilities. There are many ways of achieving synchronous operation, as we have outlined.

Then too, the problem of a nation-wide television service is a most serious one, and the production of television receivers on a commercial basis is going to be seriously impaired until some such service is available. The general public can hardly be expected to purchase televisions for home use until it is assured that there are really pictures to tune-in. In this connection, it seems highly probable that in the beginning at least we shall make use of the so-called "radio movies." C. Francis Jenkins, Frank Conrad of Westinghouse and others have already worked out practical systems operating on this principle. The subjects are first recorded on a motion picture film from the negative of which any desired number of positive prints may be made. One of these is placed in a transmitting device which scans each frame line by line.

#### FILM PICKUP IS BEST

The advantages of the film pick-up are numerous. The subjects may be filmed under the ideal conditions of the motion picture studio and with all the talent desired. The positive prints may be widely distributed and broadcast by any station without special skill or expensive equipment. Thirdly, it is possible to effect a nation-wide hook-up without the use of wire lines. Lastly, this uniform service over a large part of the country will usher in an era of what we may call "sponsored television." In other words, it will be at once possible to sell television service to large advertisers, much after the manner in which time on the broadcast air is now sold.

Further information regarding television, including the daily television broadcasts from Station WCFL, can be procured by using one of the Business Reply Postal Cards printed on page 3. No stamp is required.

## Milking the Radio Way

**F**ARMERS in Michigan use the radio for finding out at the earliest moment when the next zero wave is due and the latest news of the markets and for making fireside whoopee. Lately they have found that jazz makes the cow contented and give more milk. Many radio sets are going into dairy barns.

An owner who presented his herd of twenty cows with a set reports that he was milking eight at that time. The next week, under the same care, feed and water as the week previous, these cows produced seven pounds more butter and did not drop back. He explains this on the theory that milk is made while you wait. The cow's mental impression while being milked determines the quantity of milk she lets down. The glands center around the nerves of the cow, and the nerve center starts at the head. When she is happy the milk flows freely. Doubt it? Slap her on the back with the three-legged stool and see her hump up and withhold.

Some enterprising dairymen find other barn joys in wireless. One listened to a football game in California play by play as a result of placing the loud speaker, connected with an extension cord, behind the cows he milked.

# Some Popular Entertainers

Listeners at the German Hour on Sunday evening have a treat in Helen Holstein, leading star in German Light Opera company.



Another realistic touch of Europe is given by Joe Lenz, the Alpine Tenor and Yodler.



Luella Fiertag won the American Singers' Society contest for the best soprano in the middle west. Then she was soloist for the Chicago Symphony Orchestra, later being with a German Opera company. She is heard during the German Hour over WCFL.



See the familiar face of "Aunt Jemina" and the other three of her famous quartet. On Tuesdays, Thursdays and Saturdays you hear William Carr, first tenor; George Fuggitti, barytone; James Arnold, bass, and William D. Burns, second tenor.

# The Junior Federation of Labor

## *Juvenile Movement Sponsored by WCFL Has Remarkable Growth and Wide Influence*

By AGNES B. CLOHESY\*

**I**N a recent charming book of verse for children by Dorothy Aldis, there appears the following child-like confession:

I've been bad and I'm in bed  
For the naughty things I've said.  
I'm in bed. I wish I had  
Not said those things that were so bad.  
I wish that I'd been good instead.  
But I was bad. And I'm in bed.

But if it is four fifteen in the afternoon and a sympathetic mother will permit him to tune in on the Junior Federation hour on Station WCFL, being in bed is not so bad, for many things of interest to the youthful listener come on the air at that time. The last edition of WCFL Radio Magazine contained an account of the beginning of the Junior Federation of Labor. Now, we will chronicle the more recent doings of this growing and promising organization.

At the date of going to press, the membership has grown to something more than 23,000 members. Letters have been received from more than 12,000 children, living in Chicago, in Illinois, in adjacent states and at far distant points.

On the Chicago school programs more than 700 children enrolled in Chicago public schools have been present in the studio to take part in the programs. This does not take into account children who have come to the studio informally on Saturday afternoon, which has been reserved for that purpose, or informally on other occasions, and it does not take account of the 400 children who attended the Christmas party at the studio on Saturday, December 22, 1928. From present indications, there seems to be no limit to the membership possibilities of this club.

Not only have the children shown a spontaneous interest in the club, but the utmost enthusiasm and co-operation has been displayed by parents, principals and teachers. A number of Chicago public school principals have come to the studio with their students and have given most interesting talks over the radio. Teachers have been most helpful and generous in giving time to these broadcasts.

All who have visited the studio during the Junior Federation hour have been impressed by the friendly spirit and uniform courtesy of the officials of the station. Franklin C. E. Lundquist, business manager of the station and founder of the Junior Federation, Announcer Harold O'Halloran and Musical Director Burt Squire

have become very popular with visitors, listeners and members. The following letter is only one of many:

Dear Miss Clohesy,

Tilden Technical High School Choral club wishes to thank you and the kind men in charge of Station WCFL for the privilege of singing over the radio on last Thursday. It was a great experience for those who took part and for those of the student body who listened in—and there were many listeners. I might add that seldom does a large group of boys meet with the pleasant reception accorded Tilden's boys at WCFL. No one seemed to be put out by their noise or numbers. That staff evidently understands young people and we teachers appreciate that understanding.

Juliana Wild, Director  
Tilden Technical High School Choral Club.

On Saturday, December 22, a Christmas party was given at the studio for members of the Junior Federation. More than four hundred children were present. Presents of whistles, caps, candy, cakes, story books and toys were distributed by Santa Claus in person. Songs, recitations and other entertainment were broadcast by the guests. And then there was a big surprise. Superintendent Bogan with his daughter Catherine came to the party, greeted the boys and girls in the studio and talked over the microphone to those who were listening in. The club's first Christmas party was a great success.

Through the co-operation of Superintendent Bogan, principals and teachers, children from many Chicago schools have visited the studio and have put on programs. Vocal music by classrooms, glee clubs, choral clubs, and soloists, dramatic programs, debates, civic and patriotic numbers, talks by educators, civic leaders, social service experts and students, children's stories by students of the kindergarten department of the Chicago Normal college are some of the things provided for the Junior Federation hour. One high school gave a delightful performance of "Bohemian Girl." A fifth grade group produced an entire operetta, "Under the Sea." The Junior League of Chicago put on Robert Louis Stevenson's "Treasure Island." A production of "Oliver Twist" by the Jack and Jill Players of Chicago, juveniles, is promised for the near future. A program entitled "A Day in the Junior High School," will show the activities of that much discussed school. Announcement of current happenings of interest to children is made. Suggestions for modification or additions to these offerings are welcomed by the program directors of WCFL.

The Junior Federation hour is accomplishing at least three things. It is furnishing suitable entertainment for children in their homes. It is acquainting parents and public with the varied activities of Chicago public schools. It is establishing friendly contacts between children, their parents and labor and is promoting present and future good will between labor and the public.

\*Miss Clohesy, president of the Elementary Teachers' Local 199, is chairman of the committee of teachers appointed by Superintendent William J. Bogan to represent the Chicago Public schools in conducting the Junior Federation. Supt. Bogan is honorary president of the Junior Federation. The other teachers serving with Miss Clohesy are Mrs. Lucille H. Schacht, president of the Federation of Women High School Teachers, Local No. 3, and James A. Meade, president of the Men Teachers' union, Local No. 2.—Associate Editor.

# Junior Federation Pictures



A few of hundreds of the kiddies who make up the enthusiastic membership. Several dolls and a kitten feel quite at home in their surroundings. Perhaps honorary members.

Every Monday evening the Chicago Boys' Club is heard over WCFL. Here we have the Boys' Club Harmonica Serenaders, Max Scolnik, Mike Schliter, Clarence Graf and Edward Engman.



Some older boys and girls. They are members of the Glee Club from the Hoyne Continuation School, Nellie F. Ryan, principal, 45 East Illinois street. They are not hard to look at.

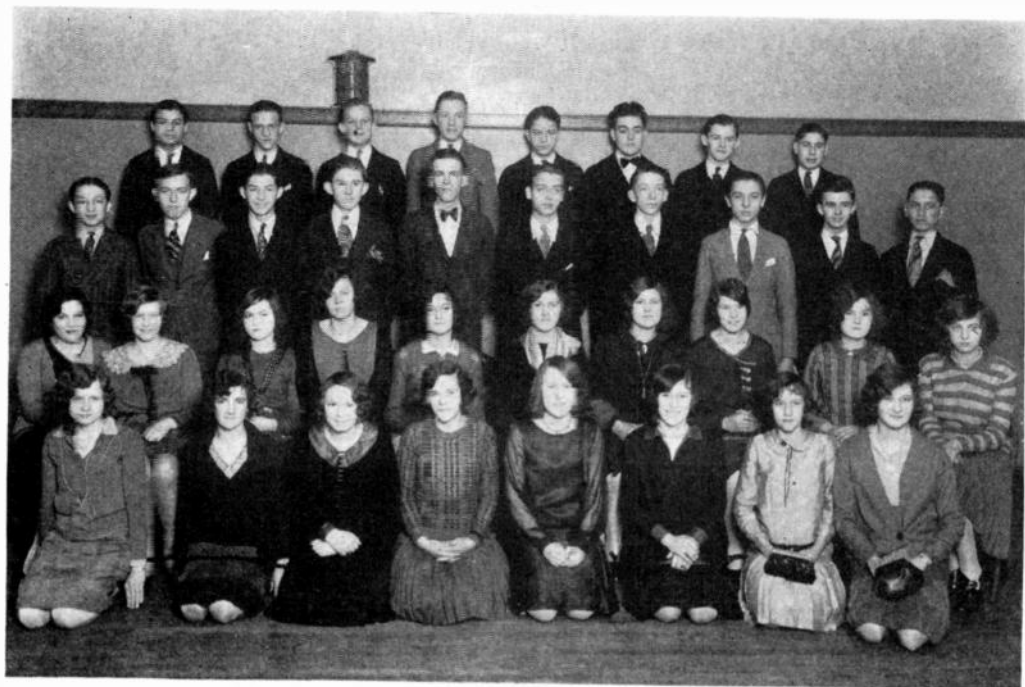

# What the Kiddies Write About

## *Interesting Revelations in Letters From Members of Junior Federation*

FROM the thousands of letters from the kiddies it is plain that they're happy to be just what they are—merely kids. The boys and girls of our Junior Federation show no undue desire or haste to be grown-ups. Even the older set, those entering the teen age, who might begin to feel the lure of bigger things, find in the sweet, simple, homely joys of childhood rich satisfaction, that brings upon the mature reader of their childish letters a mellow feeling. They make vivid the receding memories of his own early days when the world was most always bright and good, and when just living had everything else beat.

One finds, on the other hand, in the letters our boys and girls have written that they are small models of all older persons. The lads and lassies say plainly that their lives are made up largely of needs, of hopes, of possessions and of love of play. Surely few ever get old enough to feel free from these elementals of a happy existence. So the child and the grown-up meet in unity of common aim and effort and method.

Taking at random a hundred or so from the mass of letters from our Juniors the lover of human nature, especially child nature, sits himself for an evening of rare enjoyment. He tries to find something good, something entitled to special mention, but he grows troubled by the fact that practically every letter is so cute and smart that he would like to have them all printed in full with the names and addresses of the writers. Since he cannot do that impossible feat he tries to think what he ought to do about it. So he drops over his typewriter and endeavors to recall how he felt and acted when he was the age of the Juniors. Thus hours pass mostly in memory musings and in little writing. However, just sitting and thinking is often a high diversion.

### BOYS AND GIRLS ALWAYS THE SAME

The investigator finds that today's boys and girls are precisely like those of a generation or two ago, in spite of the fact that then the kids had no radio to give the evening's entertainment and no Junior Federation to join. A number of our little friends write to us on typewriters. That is something rather new. And you would be surprised to see what good looking letters they turn out. How easy to read! We find it hard to resist printing them.

One finds from the Juniors that most of them have brothers and sisters. They reveal their names and ages. Often they are older than the club members and about as often there is a little baby in the home, with the usual promise that when the little dear gets to be three or four it will be a member, too, and wear a microphone as the emblem of the order. The average age of our Junior letter writers is between seven and eight. None are backward on this point. Age may be serious later.

Chums, chums—they all name them and often describe their associates. Not one of our members has a

girl friend or boy friend—just chums. The word actually sounds good, although old-fashioned.

It is perhaps unnecessary to say that all our Juniors over six go to school and that they try to have their lessons and obey their teachers. Generally everyone is proud to say what school he or she attends, the name of the teacher and the studies they have. Scarcely one of our writers fails to say that the teacher is kind and helpful. If there are any bum teachers in Chicago or elsewhere we have no record of it.

It ought to interest many to know that the Junior Federation members do not rely solely on the radio for musical education. Practically all are taking lessons on some instrument or play in the school band. There is much mention of French horns, saxophones, pianos and violins. It is evident that every home is well equipped with pans, for invariably our youngsters take part in the "Tin-pan Parade."

### OUR WONDERFUL DOG FAMILY

Our children are great lovers. Of course, they love their parents, brothers and sisters, teachers and chums. They all say so. They also have pets they are warmly attached to. They know their gold fish and call them by name. Likewise their canaries, cats and billy goats. If any home in the wide extent covered by these letters is without a dog, and the best dog in the world, the letters do not show it. Some of the dogs in our big family have wonderful names—so many Kings, Dukes, and Princes as well as the more common Fidos, Towsers and Brunos. Then a host of noble animals with such disreputable names as Sport, Bozo, Bum, Pest and Brute. A few of the nice lady dogs are called by such names as Gypsy and Topsey. All our dogs are loyal radio fans. One boy tells how his jumps up when the "Tin-pan Parade" starts and marches with the procession till the music stops. The Juniors' pets are all smart and alert watch dogs with no bad habits except barking and chasing cats. They are clean dogs, too, for the Juniors attend to the washing themselves. One boy is never late to school because his dog wakes him every morning at the right time. Eleanor writes that she knows her dog, Jack, is smart because five times he got away from the dog catchers and her papa never had to pay but once to get him out.

Athletics will surely not fade and fail under the moving force of this up-and-coming generation. They are fiends for swimming, skating, coasting and racing. Nearly all our boys belong to some champion football team and the girls try basketball as well as the more refined dancing. One of Chicago's twelve-year-olds is destined to be a hundred percent American, confessing as he dross that he is addicted to golf.

Obedience to laws and regulations is here to stay, despite the outbreaks of gangsters. Our institutions are safe in the hands of the Junior (Continued to page 30)

# Interesting Features of

|                            | MONDAY  | TUESDAY  | WEDNESDAY  | THURSDAY  |
|----------------------------|---|--|--|---|
| 7:00 a. m. to 9:00 a. m.   | Early Risers' Club—Music and Setting-up Exercises.  | Early Risers' Club—Music and Setting-up Exercises.   | Early Risers' Club—Music and Setting-up Exercises.   | Early Risers' Club—Music and Setting-up Exercises.  |
| 9:00 a. m. to 10:00 a. m.  | Television Broadcast on 146.25 Meters. Call Letters W9XAA.  | Television Broadcast on 146.25 Meters. Call Letters W9XAA.   | Television Broadcast on 146.25 Meters. Call Letters W9XAA.   | Television Broadcast on 146.25 Meters. Call Letters W9XAA.  |
| 10:00 a. m. to 11:00 a. m. | Chicago Municipal Program Direct from Executive Office in the City Hall.  | Chicago Municipal Program Direct from Executive Office in the City Hall.   | Chicago Municipal Program Direct from Executive Office in the City Hall.   | Chicago Municipal Program Direct from Executive Office in the City Hall.  |
| 12:00 noon to 1:00 p. m.   | Pipe Organ Concert, Roy Farr, Organist.<br>Weather Forecast.<br>Announcements.  | Pipe Organ Concert, Roy Farr.<br>Weather Forecast.<br>Farmers Union Livestock Commission Talk.   | Pipe Organ Concert, Roy Farr, Organist.<br>Weather Forecast.<br>Announcements.   | Pipe Organ Concert, Roy Farr.<br>Weather Forecast.<br>Farmers Union Livestock Commission Talk.  |
| 3:00 p. m. to 4:00 p. m.   | Music of the Nations, WCFL Henke Orchestra.<br>Chicago Boys' Club Program.  | Music of the Nations, WCFL Henke Orchestra.<br>Piano Recital by Theo. Mohr. Lundquist Ensemble.  | Music of the Nations, WCFL Henke Orchestra.<br>Musical Pot Pourri.   | Music of the Nations, WCFL Henke Orchestra.<br>Violin Recital by Al Henke. Lundquist Ensemble.  |
| 4:00 p. m. to 5:00 p. m.   | Henke String Trio.<br>Junior Federation Club, Junior High Schools Participating.  | Dorothy Fausel, Soprano.<br>Junior Federation Program.   | Clarinet Concerto, Chas. Smiley.<br>Junior Federation Club Co-operating with Chicago Board of Education.   | Dorothy Fausel, Soprano.<br>Junior Federation Club.   |
| 5:00 p. m. to 6:00 p. m.   | Union Label League, H. E. Scheck, Pres.<br>Lundquist Ensemble.<br>Bulletin Board, Labor Flashes, Market Reports.<br>Farmers Union Talk. | Bakers and Confectionery Workers Program.<br>Studio Ensemble.<br>James Bruck, Editor Federation News.<br>Bulletin Board, Labor Flashes, Market Reports.<br>Farmers Union Talk. | Retail Clerks Association, Harry Winnick, Speaker.<br>Shut-ins Program by Mrs. L. A. Patterson.<br>Lundquist Ensemble, A. Linick.<br>Bulletin Board, Labor Flashes, Market Reports.<br>Farmers Union Talk. | Painters Union Local 194, Ed Nelson, Speaker.<br>Henke String Trio.<br>Charles Wills, Member Executive Board C. F. of L.<br>Bulletin Board, Labor Flashes, Market Reports.<br>Farmers Union Talk. |
| 6:00 p. m. to 7:00 p. m.   | Organ Recital by Roy Farr.<br>Southerland Hotel Orchestra.<br>Southerland Hotel Orchestra.  | Organ Recital by Roy Farr.<br>Southerland Hotel Orchestra.<br>Aunt Jemima Jubilee Singers.<br>Southerland Hotel Orchestra.   | Henry Hoople, Swedish Comedian.<br>Southerland Hotel Orchestra.<br>German Street Band.<br>Southerland Hotel Orchestra.   | WCFL Concert Ensemble, Bernice Karasick, Soprano.<br>Southerland Hotel Orchestra.<br>Popular Program.<br>Southerland Hotel Orchestra.   |
| 7:00 p. m. to 8:00 p. m.   | "Our Field Museum" By Miss M. Cornell.<br>WCFL Concert Ensemble, Earl Emory Edwards.<br>Popular Program.                                | WCFL Concert Ensemble, Harrold O'Halloran, Soloist.<br>Leiter Store Program.   | WCFL Concert Ensemble, Miss H. Ford, Soprano.<br>Popular Program, Franklin Greenwood and Baiter Warren   | "Biographies in Bronze" by Dr. C. Copeland Smith, (Stories of Famous Men).<br>Lundquist Ensemble.   |

## Senators Support Station WCFL

(Continued from page 22)

it; and, in the second place, it seems to me that the commission ought to recognize the importance of having one station at least that is under the control of organized labor which may broadcast the ideals and principles for which labor stands to the millions of working people during the nighttime, the only time when the great masses can listen to it."

Mr. McKELLAR. "I agree with the Senator entirely. He has been very active in all radio legislation and has done splendid work in regard to it. I hope he will take the lead in seeing that this station has proper rights accorded it under the law."

Mr. DILL. "I must say to the Senator in reply to his suggestion that my business is to try to frame and assist in passing radio legislation and not to try to administer it. The Radio Commission is charged with that duty. I am always ready to give it suggestions, but it seems that it should be able to work out a system whereby a station of this kind may be taken care of in the broadcast spectrum."

Mr. McKELLAR. "I, too think so; but if for any reason that can not be done, it is our duty to enact such legislation as will compel it to be done."

Mr. HEFLIN. "Mr. President, will the Senator permit me to interrupt him?"

Mr. DILL. "I yield."

Mr. HEFLIN. "If when the facts have been submitted, and the Radio Commission turns down a request that is so reasonable and fair as this, if the appeal of organized labor does not move the commission, I think the Senate can adopt a resolution condemning the commission for its conduct."

Mr. DILL. "Of course the Senate could adopt such a resolution and grant a wave length if it saw fit, but I do not think that is necessary. I want to call attention to the fact that the great Radio Trust, composed of certain large organizations that have made agreements in control of radio—the General Electric Co., the Westinghouse Co., the American Telegraph & Telephone Co., the United Fruit Corporation, and the Radio Corporation of America—have six clear channels, to say nothing of the chain-station rights which they have, to extend their programs all over the country; and they are granted those channels for unlimited use, with tremendous power of from 25,000 to 50,000 watts, while the labor station, located as it is in the center of the country at Chicago, has been limited to 1,500 watts, and

# WCFL's Weekly Program

|                           | FRIDAY   | SATURDAY  |                            | SUNDAY   |
|---------------------------|--|---|----------------------------|--|
| 7:00 a. m. to 9:00 a. m.  | Early Risers' Club—Music and Setting-up Exercises.   | Early Risers' Club—Music and Setting-up Exercises.  | 10:00 a. m. to 10:45 a. m. | Copeland Smith League, Dr. C. Copeland Smith.  |
| 9:00 a. m. to 10:00 a. m. | Television Broadcast on 146.25 Meters. Call Letters W9XAA.   | Television Broadcast on 146.25 Meters. Call Letters W9XAA.  | 11:00 a. m. to 12:15 noon  | Chicago Ethical Society, Dr. Horace J. Bridges.  |
| 10:00 a. m. to 11 a. m.   | Chicago Municipal Program Direct from Executive Office in the City Hall.   | Chicago Municipal Program Direct from Executive Office in the City Hall.  | 2:30 p. m. to 4:00 p. m.   | WCFL Studio Program.   |
| 12:00 noon to 1:00 p. m.  | Organ Concert, Roy Farr.<br>Weather Forecast.<br>Announcements.  | Organ Request Concert, Roy Farr.<br>Weather Forecast.<br>Announcements.   | 4:00 p. m. to 5:00 p. m.   | German Radio Hour (American Admirers of German Art).   |
| 3:00 p. m. to 4:00 p. m.  | Music of the Nations.<br>Musical Pot Pourri.   | Music of the Nations.<br>Musical Pot Pourri.<br>Lundquist Ensemble.   | 5:00 p. m. to 6:00 p. m.   | Studio Program.<br>Dictagrapher, N. B. C. Program.   |
| 4:00 p. m. to 5:00 p. m.  | Cello Recital by Paul Liebezeit.<br>Junior Federation Club.  | Dorothy Fausel, Soprano.<br>Junior Federation Club, co-operating with Chicago Board of Education.   | 6:00 p. m. to 7:15 p. m.   | Copeland Smith League, Question Box.   |
| 5:00 p. m. to 6:00 p. m.  | Henke String Trio.<br>Lundquist Ensemble.<br>Bulletin Board, Labor Flashes, Market Reports.<br>Farmers Union Talk.   | Illinois League of Women Voters.<br>J. P. Dunn for Brotherhood of Railroad Clerks.<br>Mak and Max, Comedy Team.<br>Bulletin Board, Labor Flashes, Market Report.<br>Farmers Union Talk. | 7:15 p. m. to 8:00 p. m.   | Studio Program, Roy Farr, Organist<br>Southerland Hotel Orchestra.   |
| 6:00 p. m. to 7:00 p. m.  | Recital by Vella Cook, Contralto; Roy Farr, Organist.<br>Southerland Hotel Orchestra.<br>Popular Program with Franklin Greenwood and Vella Cook.<br>Southerland Hotel Orchestra. | Popular Program; Baiter Warren, Franklin Greenwood and Elinor Masquelet.<br>Southerland Hotel Orchestra.<br>Dixie Minstrels.<br>Southerland Hotel Orchestra.                            |                            | <i>Haynes Radio Log Free! Fill in and mail one of the Business Reply Postal Cards on page 3 and a copy of the latest revision of Haynes Radio Log will be sent to you. No postage stamp is required.</i> |
| 7:00 p. m. to 8:00 p. m.  | WCFL Concert Ensemble, Burt Squire, Baritone.<br>Leiter Store Program.   | WCFL Concert Ensemble, Roy Farr, Organist.<br>Music Publishers Period.  |                            |  |

limited to broadcasting during the daylight hours.

Having granted Mr. Insull's company a permit for 50,000 watts in Chicago, which divides the time with the Prairie Farmer station of 50,000 watts, the effect was such as practically to drown out the little labor station. So the commission has granted a permit to it to build a 50,000-watt station, but as yet has refused to grant them the short wave length upon which they can rebroadcast their programs throughout the Nation to little stations which will use the one-wave length.

Mr. President, I will not take more time, but will ask to have the letter printed in full at this point in the RECORD following my remarks."

The Presiding Officer. "It is so ordered."

This letter, which created such favorable senatorial comment is printed in full on pages 8, 9 and 56.

## What Kiddies Write About

(Continued from page 29)

Federation. One gathers this easily from the many letters in which most of the boys and girls tell that they follow the rules. Occasionally a failure. Two broken-hearted kiddies write in that they were naughty just before the parade and had to put their pans away.

Dorothy May writes that she always picks up her clothes and toys and helps her mother by going to the store and setting the table, but that fourth rule is a hard one, because Dorothy dislikes to go to bed. Mardell wants to know: "Daddy Harold, girls and boys that want to be good and have nice manners have to be nice to everyone, don't they?"

Mildred Marie wants us to excuse her writing, which she says is not very good. Strangely it is very easy to read. She is easily forgiven, especially since she sends in a long list of cousins with their names and ages for membership in the club and a lot of cross marks and zeros to indicate her love of Sister Lou. "A girl in our room got over 52 girls and boys to become members. I guess I can get that many for you," indicates the fiery zeal of another of our little friends.

Some children let us know they have the right kind of fathers. Martin got his father to write his letter for him while he went for a "package of Union Workmen tobacco." Another boy tender-heartedly writes that he saw a deer his uncle shot. "I felt sorry for it, for it was a nice deer." One brave little fellow tries to conceal the pathos of his plight. He says only: "I like to play football and basketball, but cannot because I have a weak heart." Dorothy, although she (See page 76)

# HELP WANTED

By JACK WOODFORD

A GIRL friend of mine, who last year made a living writing confession stories for the sex magazines, has a job this year, at a rattling good salary, which is the strangest I ever heard of. She is the head advertising copy-writer in the classified advertising department of one of the largest daily newspapers in the United States. She assures me that her position is not unique. Almost all large newspapers, it appears, have her counterpart in endeavor, if not in genius.

This work of hers as a writer of copy for classified advertisements has nothing to do with the writing of ads for people who have old pianos and radios and other such decrepit lares and penates for sale. Over 90 per cent of the advertisements she writes are for the Help Wanted columns of the classified section of her paper. Last Sunday, at my invitation, she brought this classified section to my house. We spread it out upon the floor, and analyzed its eleven pages.

It seems that the classified sections of newspapers are drawn and quartered by a system of agate lineage. First, as she sprawled upon the floor, blue pencil in hand, chin in palm, elbow resting upon the floor, she figured up the entire lineage devoted that Sunday to Help Wanted, Male and Female, classified advertisements. Then, ad by ad, she checked off those which she called phonies. Some of these phonies she had herself written. Others had been written by advertising agencies with departments dedicated to the writing of copy for the classified columns on a service fee basis.

Some, again, had been written by gifted men in the employ of the firms which inserted them. She checked off as phonies only those of which she was absolutely certain—leaving any doubtful ones in the bona fide category. The phony ads constituted 67 per cent of all the lineage in the Help Wanted sections. You don't believe it? Nor did I. Here is one of the phonies which she had written herself:

Suppose that you were to sit down, take a piece of paper and a pencil and start to make a picture of a perfect job. . . . What's the first thing you'd put into this picture of the ideal job?

## MONEY! OF COURSE

We have to offer to you the largest commissions, the finest lots and the most perfect office aid, in the way of chartered cars and busses and live leads, of any real estate firm in the city. Therefore, in this ideal job, you'll make more money than you ever made before in your life, no matter what you may be making now.

You don't need to do missionary work to sell our properties. In our new South Side subdivision there are already thirty bungalows being erected. You don't have to talk vaguely about improvements to come. The improvements are already there. Water, gas, electric light wiring, sewers and sidewalks!

It doesn't matter whether or not you've ever had any experience selling real estate. If you're ever going to snap out of that rut you're in, *now* is the time to do it. It is nothing at all unusual for men who never made over \$40 a week in their lives to come in here and, after a week or two of experience, start to make \$100, \$200, \$500 a week. . . . There's absolutely no limit to what you may earn.

Drop in today for a talk. We'll tell you how we are going to train you, by our psychological processes. If you make good right away, as many do, we'll appoint you a crew manager, at a salary of \$250 a week, and all expenses.

And advancement with us doesn't stop there. If, after a year or so as a crew manager, you show unusual capabilities, we'll give you a whole subdivision where you'll have crew managers under you. You'll draw, beside a large weekly salary, an overriding commission on everything sold by the men under you.

There is room at the very top with us. All of our executives came to us as salesmen. Some of them were bookkeepers or clerks in department stores two or three years ago. Now they are drawing down their \$50,000 a year, and more! *You* can do what they did. Don't hesitate. Come in and talk things over, anyway. We have on our staff a characterologist who can tell you *absolutely* whether or not you are fitted for real estate salesmanship. Come right in today—don't put it off.

This was not the longest classified advertisement in the paper. There were much longer ones, some of them almost a full column, containing from three to five hundred words in agate type, with headings running as high as twenty-four point type.

Also, scattered throughout the classified Help Wanted section, were various ambiguous smaller ads. Here is one of them—one that my friend had written:

Several times in the past I have selected inexperienced men and carefully trained them for my work. If you can pass the short, interesting test I apply to applicants, you need not fear that your earnings will be unsatisfactory. You can practically name your own salary. The work I have to offer is not hard, and the hours are short.

These phony ads, as I have said, constituted 67 per cent of all the lineage in the classified columns—*not* 67 per cent of all the ads. Figuring up the number of individual classified ads, the phony ones amounted to 31 per cent of the total. This difference was due to the fact that the bona fide ads were all much shorter, some of them not over two or three agate lines.

## II

My friend receives her salary directly from the paper. She is part of the Service offered free to advertisers. A real estate man wishing to insert an advertisement for salesmen may either write the advertisement himself, have his agency write it, or, if he has no agency,



simply pay for so many lines, give the classified copy-writer his general ideas, and have his ad written for nothing.

Perhaps, by this time, you are wondering, as I did, why employers in the America of today should be seeking employes after the manner of the Romans seeking the Sabines. For an explanation we must go downtown to the offices of Smug & Sleek.

Don't jump to the conclusion that there is anything shady about the Smug & Sleek Real Estate Company. Mr. Smug was once an important city official and Mr. Sleek was once a Monte Carlo croupier of incomparable tone. He looks just too cute for anything in a plug hat. But he is not too cute for anything.

Upon his manly form one day rested the appreciative eye of the daughter of a wealthy man. She forthwith imported him to America as her husband. Because she is an active churchwoman she thought it best that he have a visible means of support of which even God would approve, so she bought an interest in the real estate firm for him. She thought, no doubt, that he would call at the office once a week, and spend the rest of his time more felicitously. Imagine her chagrin when he suddenly developed amazing business ability and began to out-Babbitt the Babbitts!

Now, among local realtors, he is regarded with awe as a sort of miracle worker. He has, in fact, worked at least one miracle. When he was imported he was, to all intents and purposes, kept. Now, through managing his keeper's estate, he has put himself in such a position as to make it necessary for her to come to him for cigarette money. Not only is he keeping her, but he actually maintains a separate establishment of serail hue in a Byzantine bungalow atop a huge apartment building, and in it dwells one lovelier than his wife.

Not long ago, when the father of this lady discovered the evil ways into which his daughter had fallen, he threatened to send Mr. Sleek to prison. Mr. Sleek thumbed his nose at him and told him to start something. Never before having been thus handled, Papa was furious. He retained all the most able lawyers in town to railroad Mr. Sleek, but Mr. Sleek knew his pomegranates and bluffed them cold. He is today looked up to universally.

Smug & Sleek at first interested themselves only in the legitimate illegitimate management of estates, and in the sale of ordinary and extraordinary properties throughout the city; doing, in short, a conventional and decidedly profitable business. But one day there came to town a Mr. C. Hinch Blaverton. Mr. Blaverton landed, according to his own admission, with exactly \$4.86. This modest sum he turned into \$5,000,000 in less than four years.

Mr. Blaverton's mode of procedure was simplicity itself, and not original, except at one point. He went beyond the city limits, bought up old farms for a few dollars an acre, and sold them as subdivisions at about the same price a square foot as he had paid for them an acre. It was his manner of selling these lots that was wholly original. He used most of the old tricks of the subdivider, including the running of sidewalks through his cow pastures, with arty looking street markers at each intersection. But he did not, in the ancient manner, hire a small force of men to sell his subdivision on a part salary, part commission basis.

Instead, Mr. Blaverton hired men literally by the thousand. An entire floor of a downtown office building was used by his high-pressure, live-wire sales managers. Every day, in all the daily papers, he literally loaded the Help Wanted columns with appeals for help. He ran these ads under every possible classification and subdivision. For instance, here is one he inserted under the Bookkeepers Wanted sub-heading:

Wanted, man who is thoroughly experienced as a book-keeper. One who is dissatisfied with his present earnings and who would like to increase them. Call Suite 1008, Booster Building.

The dissatisfied bookkeeper, calling at Suite 1008, was met by a high voltage salesman with the glorious title of Sales Manager. After a short pep talk, he was asked to report at the next "meeting."

When several hundred applicants had been roped in for a meeting Mr. Blaverton would appear to harangue them. And Mr. Blaverton was some haranguer. He had his own case to point to with explosive pride. The \$4.86 that had turned into \$5,000,000. A glorious American legend; and a true one!

Out of every hundred men he harangued, Mr. Blaverton usually managed to sign up twenty-five or thirty, some on a full-time basis and some on a part-time basis. During one year he actually hired 7,342 salesmen, including both full and part-time men!

It was this new invention which revolutionized the art of the realtor in the town, for Mr. Blaverton had discovered that out of every half dozen men who could be induced to accept positions, two or three would sell at least one lot each to friends or relatives. Occasionally, carried away by the picture Mr. Blaverton painted of the future of his properties, they would even buy lots themselves.

But after the new salesman had made his proverbial single sale, Mr. Blaverton's firm lost interest in him, and he drifted away, sometimes back to his bookkeeper's desk, sometimes, indeed, to eventual success as a real estate salesman, and sometimes, I regret to state, to the river.

It was this discovery of Mr. Blaverton's, that a given number of men hired would produce a given number of single sales, that so excited the admiration of Smug & Sleek that they used all of their local drag with city officials to get him a reservation at the State penitentiary. They were, in this, unsuccessful, though they did succeed in forcing Mr. Blaverton out of business; or, perhaps, under the pressure of their persecution he merely left town, thinking that to play Naboth to their Ahab, and get five million for the rôle, was better than to stay and fight Smug & Sleek, who had the papers behind them in everything they did.

With Blaverton safely out of the running, Smug & Sleek immediately began to take up things where he left off. They began to buy old cow pastures and adorn them with sidewalks and gaudy street signs. They filled all of the papers with veiled ads purporting to offer bona fide jobs of every sort and description. And they too began to roll up new millions in the process.

Deciding that if Smug & Sleek could get away with this manslaughter God and the government would wink at it, most of the other real estate men in the town

(Continued on page 62)

# The Low-Down on Recent Tie-Up of Farmers and Labor Unions

*Leaders of Both Groups of Toilers Reach Happy  
Agreement Much to Surprise of Their Enemies*

By L. P. STRAUBE\*

"I SUPPOSE, Ed, you wonder what brings me around at this hour to disturb your peace of mind?"

The questioner, an eager young man, leaned forward expectantly at the more mature one opposite whose shrewd eyes, deep set beneath a broad expanse of brow, suggesting the student, were alight with friendliness.

"As head of an affiliated union you may consult the secretary of the Central Trades council night or day. You know a labor official keeps no hours; he is on duty all the time when not sleeping. As the proven friend of Ed Strong, James Bailey can command him any time. So spill your grief, Jim, and I'll mop it up."

"I figure it better to begin by asking you a few questions, Ed. Could you trust one you knew hated you?"

"If they were honest, why not, Jim? An honest enemy is preferable to a doubtful friend."

"But if their loyalty seemed a commodity to be bought with the fraction of a penny, what would be your attitude?"

## GETTING BOTH SIDES OF QUESTION

"Jim, our human laws provide that an accused one is innocent until proven guilty, also that he be given the benefit of any doubt. Get both sides of a question before attempting judgment. But just what are you driving at—why not speak up and thresh out your problem?"

"All right, Ed, here's the works. My bunch is all fussed up because the Central Trades council went fifty-fifty with the Farmers union in the radio broadcast station and radio magazine, letting in the Farmers union as an equal partner without that party to the agreement providing any of the money spent on either the station or the magazine. Some of the boys think that the long-standing antagonism of interests between the farmer and trade unionist is not a very good guarantee of team work necessary to make the venture all that Labor hopes."

"As usual, Jim, youth is inclined to put the cart before the horse. Take your last assertion first. Things grow on what they feed and a one-sided hatred would soon be on a starvation diet. Fact is, son, the farmer's hostility toward the trade unionist is measurable by the trade unionist's feeling against the farmer. Both are guilty of ignorance; both are the victims of the press scheme to keep the producers of the city set against the producers in the fields. In this way the exploiters of

both groups have been able to play both ends against the middle and grab profits from two directions. If both ends realized that their problems and interests are the same; and would join hands to fight the common enemy, instead of fighting amongst themselves, many things would be different.

"Big business controls the daily press. Its readers, by force of habit, find it easy to accept these ready-made opinions and be governed accordingly. The country editions teach the farmer to view with alarm the trade unionist as a lawless person peddling Bolshevik pamphlets when he is not throwing bombs, while the city edition gulls the trade unionist into believing that the farmers are soulless, selfish controllers of our food supply, demanding the uttermost farthing. In such a poison-tainted soil what but suspicion and hate could grow? Any agency for the toiler's good needs united, not divided support. For that reason the Central Trades council hooked up with organized farmers to work our common salvation.

"The job wasn't so easy. Fortunate circumstances helped some. When a state division of the Farmers union sought radio privileges it was told there was nothing doing and was advised earnestly to see the only Central Trades council that had a radio franchise. If a combination could be formed, it was suggested, what the farmers wanted might be got.

## FARMERS TREATED LIKE WARDS

"I don't know, Jim, if you sensed the scheme, but here's the way it looks: Farmers have long been treated as government wards. Politicians could not afford to turn them down. Let Labor do it. That would be clever. Just a little hocus-pocus and the burden could be shifted onto the trades unionists, who of course, could have nothing to do with their traditional enemy, the food producer. Then, best of all, the real fireworks. The politicians being the friends of the farmers, would have just the excuse they were looking for to take from the trades unionists the radio privileges they already had and deny the extensions being sought by Labor.

"That scheme went on the rocks when the Central Trades council saw the trap. It grabbed in fellowship the extended hand of the Farmers union. The council saw big business spending money like drunken sailors on shore leave to control public opinion and swell profits. Could not Organized Labor afford to swell its army by the addition of hundreds of thousands of listeners? The agreement was consummated and now stands as a monument to the essential unity of all who labor.

"Get me right, Jim. Necessity made the trades unionists 'come out of it'—to quit the dumb policy with which

\*WCFL Radio Magazine writers are specially chosen because of their personal experiences in the field of endeavor their literary venture covers. L. P. Straube is a battle scarred veteran of the labor movement, whose intimate relations with the pioneers in the organization of the farmers, enables him to present their respective viewpoints in a manner both instructive and interesting.—Associate Editor.

Labor has been cursed. Radio did it. It helped to bring about a miraculous cure well worth all the sacrifice. To let the farmers share with Labor on a basis of equality the resources of this station, without trying to commercialize on their need, went far to convince the farmers of the genuineness of Labor's attitude. The Farmers union has responded in a way that makes the future bright with promise to all. Does that cover your complaint or have you some other pet peeve, Jim?"

"You quite met my question, Ed, and have satisfied me that most of us are inclined to go off half cocked. But listen. You admit that Mr. Farmer has much the better of it. He is sure of a living with no slave driver to goad him to his last ounce of strength. Sure, in certain seasons he puts in more time, but he is recompensed by a period of comparative leisure with sufficient grub laid away to stand off the wolf. On the other hand, the city worker must pay and pay dearly for every bit of food whether he has a job or not. Every layoff, due to inclement weather or lack of work to do, means a diminished income. This uncertainty coupled with the city's certainty of the high cost of living, although it involves but the bare essentials, makes the city worker's life more trying. In spite of crop failures and bad markets the farmer seems sure of a living. The fact that as a basic food provider he is a most vital factor in the scheme of existence brings to his aid much favor and consideration from high powers. The most convincing proof that there is money in farming is offered by the retired farmers themselves. They are all well fixed. The proportion of them able to retire with decent bank accounts is far beyond that of those who retire to ease from the ranks of Labor. From whatever angle we view it the farmer is by far the more fortunate. Don't you honestly think so, Ed?"

#### EFFECT OF INCREASED LAND VALUES

"No, I don't think so, Jim, and neither would you after more serious thought. Increasing land values, rather than profits from farm products, explains the prosperity of retired farmers. Originally, I grant the farmer occupied a somewhat isolated and practically independent existence. The farm produced most of the requirements of living—the food, clothing and shelter. As barter or exchange was superseded by money, banks and bankers became the advance agents of big business. Realizing that land is the surest asset, the bankers had an idea they would help the farmer. So they publicly proclaimed their friendship for him and privately helped engineer marketing schemes to drive him into their doors seeking aid, which they were glad to extend with such charges as would make the farmers constant tribute payers. By purchased legislation the money sharks got permission to make loans greatly in excess of the money on hand, and out of it all they reaped a glorious harvest of gold and made themselves masters of industry.

"Jim, do you realize that every agency established to aid the farmer in the marketing of his goods was almost invariably made possible by loans advanced by bankers. When you get that firmly fixed in your mind you will appreciate not only the range of the banker's influence but the ruthless nature of his policy as well. Since profitable returns to the farmers would put them out of the banker's clutches, it was seen to that relief should never be sufficient to lift the farmers' burden of

debt. Simple, son, yet fool-proof in its effectiveness. Now as to the slave-driving you refer to, I have an abiding faith that most workers, being basically honest and fearing debt, are harder driven by their own consciences than by the creditors' lash or other scourge.

#### MODERN LIVING MORE THAN FOOD

"Now as to time put in. When the city trades unionist's day ends he knows precisely what he has earned. The farmer, though he toils from sun to sun, is never sure what he will receive until the harvest is sold. Inclement weather, insects and other pests are big factors, and all his labor may come to total loss. As for leisure, son, a farm with all its chores makes ease hard to find. True, the farmer's living is generally assured, but modern living is not confined to food. The other things a farmer's family needs are about as much needed as they are by the city worker's family, and they cost money, and this he must acquire either through the sale of products or through borrowing money. A comparison of the prices paid for food by city people with that obtained by farmers for the same products stirs wonder as to what good qualities are added to the commodities by the mediums to justify the rakeoff they take from both sides. The way to rid ourselves of these parasites is a matter for future discussion, but I want to emphasize now that labor, neither on the farm nor in the city, can claim independence. Each consumes the produce of the other. It follows that the greater the prosperity of each group of consumers the more they buy and the more they increase employment. Anything smelling of antagonism is dead wrong, Jim; the more the farmer gets for what he grows, the more he takes of the city's finished products, and the more the city worker earns the better for the farmer. Neither, to my notion, has much advantage in the game of life over the other; if either, the advantage lies with labor in the city. In town there are more opportunities for the seeker after a job, while in the country the demand is limited to actual farm operations, for the carrying on of which arrangements are usually fully made early in the season. Of course, you may be able to cite isolated cases to disprove my position, but, generally speaking, I am correct.

"No, Jim, you are wrong, but I hope I have been able to shunt your thoughts into the line of a nicer equity in these matters. Have you any more things that tend to keep you awake nights?"

"I should say I have, Ed. In fact, so many that I feel like an animated question mark. I get a mass of opinions and theories—good, bad and indifferent—loaded with dynamite, which never reach your ears. I trust to have the opportunity to prevent some scatter-brained mischief monger from touching off the fuse, sending the carefully constructed temple of practical co-operation into the air. What say, Ed?"

"Well, Jim, the idea with its possibilities intrigues me. Try to get the reaction of others on what I have given you. If the response received warrants it, I will go into detailed explanation of these labor relationships, theoretical remedies and actual cures as well as the idealistic dreams entertained by the sponsors of Labor's radio broadcast station and magazine. I will await tidings of your experiment, Jim, and let those we seek to honestly serve answer the question whether they want to be served in this manner or not."

# Results of Recent Inventions

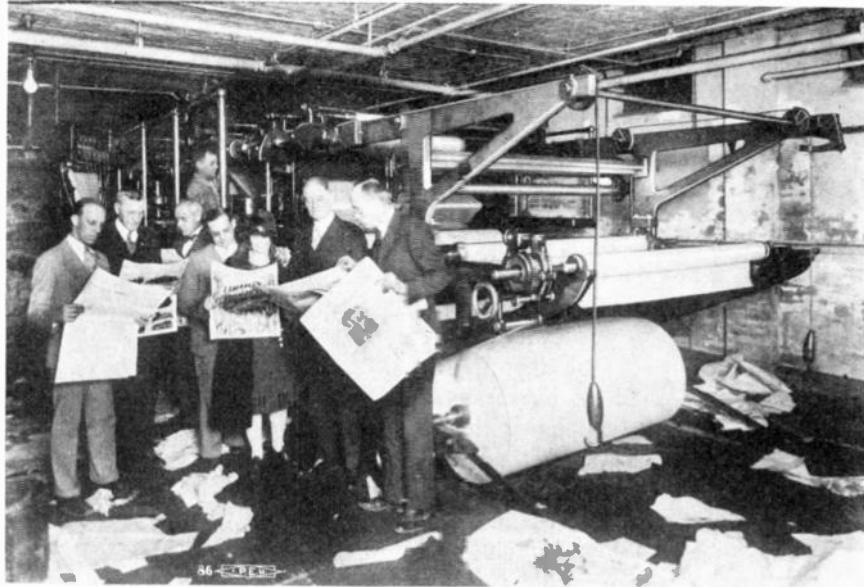

Meet the perfect waitress of the future. "Nippy," the Robot, arrives in full panoply of tea and buns in a fancy dress costume worn at the carnival dance held recently in Olympia, London. In the presence of this terrifying automaton, the ordinary serving maid promptly puts up her hands.

The world's first newspaper made from cornstalks was run off by the Danville, Ill., Commercial-News, marking a new epoch in the paper-making industry. The newsprint from cornstalks is of stronger texture than that from wood pulp, is very white, takes ink clearly and its cost of production is less.

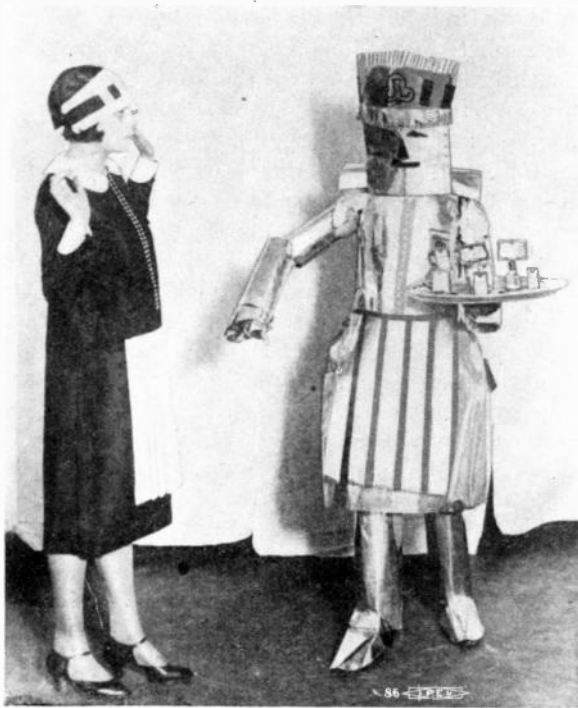

A single typist may put into operation in a thousand widely scattered offices a thousand linotype machines setting type as perfectly as if done by human hands. In the ticker tape are perforations corresponding to a letter or numeral. The code on the tape is flashed electrically. A similarly perforated tape is put through a device attached to the linotype.

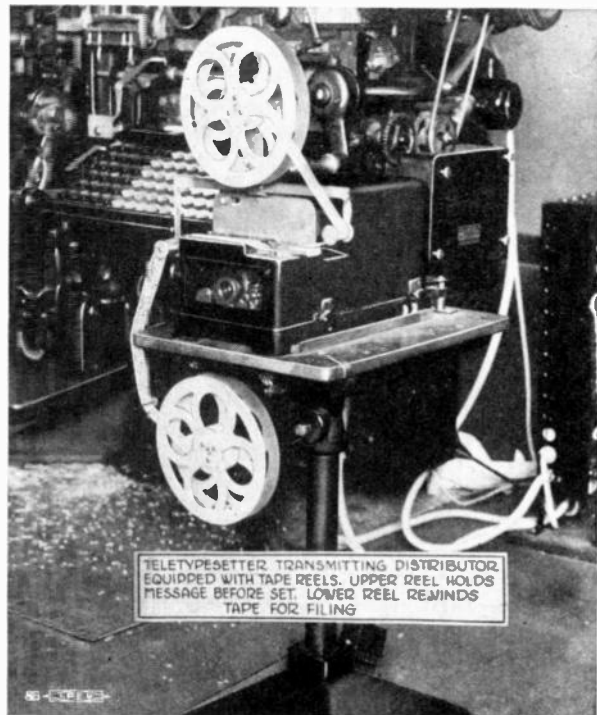

TELETYPESETTER TRANSMITTING DISTRIBUTOR EQUIPPED WITH TAPE REELS. UPPER REEL HOLDS MESSAGE BEFORE SET. LOWER REEL REWINDS TAPE FOR FILING

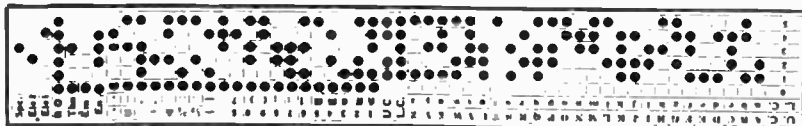

This is what a section of the Teletypesetter tape looks like.

# WCFL Radio Magazine

*The Voice of Farmer-Labor*

OFFICIAL QUARTERLY PUBLICATION OF

WCFL RADIOPHONE BROADCAST STATION  
and the Co-operative Farmer-Labor Radio Listeners' Association

## FARMERS UNION SECTION

### Let the Farmer Save Himself

WE have no program for saving the farmer. That may sound hopeless, bald and unfriendly but, nevertheless, it's a correct statement of our position toward the horny-handed son of the soil. WCFL Radio Magazine is strongly of the opinion that the farmer does not want to be saved. Furthermore, if he needs to be saved, then he is hardly worth the effort. The same is true of the urban toiler. If that be lese majesty, we stand convicted.

From information coming to us over a considerable space of time, we are convinced that the farmer is sick and tired of having zealots with questionable motives try to save him. He resents most of these efforts as harmful meddling or schemes to use him for ulterior purposes. The farmer has a mind of his own. He knows what he wants and is capable of working out a program satisfactory to him.

In the Farmers Union the tillers of the soil have a capable means of crystalizing their hopes and ambitions as well as giving forceful expression to their complaints. It is in every sense a farmers' organization, composed of the men right out on the fields and in the feed lots, and officered by their own leaders.

With the Farmers Union Station WCFL and WCFL Magazine are proud and happy to co-operate; just as we are proud and happy to co-operate with every organization within the fellowship of organized labor.

It is only the programs that Organized Farmers and Union Labor work out for themselves that will cause them to rally. The heights to which they may seriously aspire are no loftier than they can elevate themselves to by their own efforts. In other words, they must work out their own salvation. Elevation that is due to and is sustained by the intervention of outside influence is, to say the least, precarious. It may result at any time in a collapse. There is security in self-improvement. Such efforts, both by farmers and urban toilers, have and will continue to have our heartiest support.

### Farmers Union Directory

National President..... C. E. Huff, Salina, Kansas  
National Vice-pres., Joe Atkins, Wisington Springs, S. D.  
National Secretary-treasurer, Jas. O'Shea, Billings, Mont.  
Farmers Union Northwest Headquarters, Guardian Life Building, St. Paul, Minn.  
Farmers Union Mutual Life Insurance Co., Des Moines, Ia.  
Farmers Union Mutual Fire Ins. Co., Des Moines, Ia.  
Farmers Union Mutual Ins. Co. of Kansas, Salina, Kas.  
Farmers Union Terminal Association, Guardian Life Bldg., Saint Paul, Minnesota  
Farmers Union Livestock Commission, So. St. Paul, Minn.  
Farmers Union Livestock Com., U. S. Yards, Chicago, Ill.  
Farmers Union Service Association, Des Moines, Iowa  
Farmers Union Exchange, Guardian Life Building, St. Paul, Minnesota  
Farmers Union Herald (National Paper), Guardian Life Building, St. Paul, Minn.

### Farmers Union Radio Committee

Milo Reno, Des Moines, Ia.; C. A. Guthrie, Salina, Kas., and D. D. Collins, Belle Fourche, So. Dak.

### Tieup of Labor and Farmer

The radio agreement between the Chicago Federation of Labor and the Farmers Educational and Co-operative Union of America is an outstanding achievement. It notes the coming together in common effort of people who work for a living.

A generous policy makes possible the complete division of broadcasting time between these two organizations and in so doing labor shrinks from no responsibility and imposes no serious burden on the Farmers Union. The Chicago Federation of Labor maintains the entire expense of WCFL station.

The privilege of broadcasting is a high one even if not costly to the farmer. The contract agreed to between Secretary Nockels of the Federation and C. E. Huff, chairman of the Radio Committee of the Farmers Union obligates the latter to pay for each member, as the states in which the Union elects to become a party to the contract, 25 cents a quarter for a subscription to WCFL Radio Magazine.

Revenues of the station in excess of the operating expenses and the cost of publishing the magazine are to be divided equally between the two organizations.

EDWARD N. NOCKELS, Editor and General Manager  
L. W. AINSWORTH, Associate Editor, Des Moines, Ia.

January—February—March, 1929

Volume 2—Number 2

# Co-operation vs. Competition

By MILO RENO, Pres.

Iowa Farmers Union

**CO-OPERATION:** Joint action; profit sharing. A union of laborers or small capitalists for the purpose of advantageously manufacturing, buying and selling goods, or of pursuing other modes of mutual benefit.

**COMPETITION:** Contention of two or more for the same object or for superiority; rivalry. The **INDEPENDENT ENDEAVOR** of two or more persons to obtain the business patronage of a third. (Funk-Wagnalls Standard Dictionary.)

**D**OWN through the years and even today, the farmer has been and is being taught that *Competition* is the essence of good business. Never was there a more colossal fallacy. Competition can mean good business only when all businesses are in competition and big business is *not* in competition. Big business has learned that competition is expensive, and it is big business, none other, that has put the word co-operation on the map.

But, you say, big business interests do not co-operate!

Long before the Farmers union came into existence in Iowa, big business interests were co-operating. Their co-operative efforts were not as sweeping nor as open to the public as they are today; the farmer paid little attention to the program of the financial interests at that time because he was more prosperous and, therefore, more satisfied and happy.

The farmer in the years preceding the World War was more prosperous only because his needs were not as great. The financial interests have always held him in submission. Business has co-operated to protect business. Review events of the last twelve months if convincing facts are needed—ponder the innumerable mergers and consolidations with their great centralized power and stupendous financial backing.

What has the farmer done and what can he do to "meet fire with fire"—to put his business on a co-operative basis?

First of all, the farmer has been lulled to sleep and inaction by an orchestra composed of enemies whose seductive songs have had such titles as: "Produce More Than Your Neighbor;" "Get Ahead of Your Neighbor Anytime, Anyhow;" "Believe What We Tell You, But Never Trust a Farmer;" "Oh, The Farmers Can't Stick Together—Laugh With Us At Them," and "We're the Original 'Competition Boy,' Whoop'er Up With Us!"

The farmer has been lulled to sleep and the first thing he must do is to awake!

Competition is fair to everybody *if* fairness is a part of competition; competition in the matter of production is fair and justifiable *if*, as a part of competitive production, a fair price is available to all.

But competition cannot be a part of the farmer's business or his program because, without *co-operation*, he can never obtain the power, politically or financially, to meet the strength of the co-operatively-owned and co-operatively-controlled business interests.

The program of the Farmers union is predicated upon the letter and the spirit of the word co-operation. It is unassailable and it is the only program through

which the farmer can ever hope to preserve his home—ever hope to call his soul his own.

The Farmers union through its marketing institutions, life insurance, property insurance, automobile insurance, service stores, co-operative creameries and credit association, offers the individual farmer the only co-operative vehicle, the destinies of which are guided not by politicians and selfish business men but by farmers and the friends of farmers.

True co-operation is not difficult under the program of the Farmers union. When you sign a marketing agreement you agree to ship your livestock to a friendly commission house whose first interest is to obtain for you the best possible price.

When you have stopped the business of competing with yourself (by selling direct to your home packers and the old-line commission firms), and Farmers union commission houses receive the bulk of all livestock marketed, then you can command, not ask a decent price for your products.

When you have learned the true spirit of co-operation you will denounce the competition you have supported in years gone by through the purchase of insurance policies from companies who immediately handed the money, which you have invested, to the moneyed interests of the nation to work against you.

Farmers Union insurance, plus the Farmers Union credit corporation, means that every dollar you have invested and which is available for purposes of credit is put to work in the form of loans to the farmers of the middle west. When you buy Farmers Union insurance you not only have protection in a sound company but you are lending co-operative effort either to yourself or to other farmers.

The farmer nor no other person can "have his cake and eat it, too." The farmer cannot be a competitor and still hope to be a co-operator.

The farmer who sells his hogs direct to the packers because he can get a few more cents per pound over and above all expenses for shipping is competing with himself as well as every other hog raiser. He will get a few more cents today but his hogs will always sell for many dollars less than they are worth until he become a co-operator.

The barren years of the past speak for the system of competition as applied to farming. The hope for the future lies alone in a gigantic CO-OPERATIVE movement and the Farmers union stands independently alone, ready and waiting to receive and aid the fine progressive farmers of America.

Professor Virgil Jordan, chief economist of the Federal Industrial Conference board, made the public statement recently that "agriculture as a whole lacks \$5,000,000,000 a year of being a paying concern."

Given another interpretation, this statement simply means that the farmers of America fail by \$5,000,000,000 to get even cost of production.

There is but one choice left for the farmer—he

must immediately join the co-operative marketing movement—he must substitute co-operation in all its phases for competition, or he must prepare to quit the business of farming.

Let us substitute joint action; profit sharing and mutual benefit, the spirit of co-operation, for contention, superiority, rivalry and the independent endeavor of competition.

It is the only high road out of the quagmire that is agriculture today.

Let us become brothers in a common movement, in common spirit. Co-operation is our only escape from peasantry—our only hope for a return of the happiness that was once to be found so abundantly in the farm homes of this nation.

## More Work for Congress

**M**ANY people strongly convinced that the farmer needs and is entitled to relief, whether by the Haugen-McNary experiment or by the doubtful expedient of revising the tariff upward, are also firm in the notion that relief ought to be passed along. Others are in need.

This is the feeling of the small independent tradesman crying out aloud against the aggressions of the chain-store methods of competitors. Neighborhood groceries and drug stores daily fall by the wayside, victims of what they term unfair competition. Small manufacturers struggle hopelessly against mergers of concerns so large that they can safely ignore the yelping little fellows.

Another grievance voiced against things as they are, is by business men compelled to borrow money to carry on. They complain of higher interest charges imposed by lenders, who, emboldened by the imperative demand for funds for stock-market operations, are now mulcting legitimate borrowers in instances said to be as much as 15 percent. One practice reported is to make the note, say for \$100,000, at 6 percent, with the agreement that \$50,000 undrawn balance must be maintained—an equivalent of 12 percent.

It is suggested that after Congress has concluded surveys to determine whether the prohibition law is observed and whether the Washington monument is still standing and after its committee on astronomy has reported on the time of the setting of the sun, it may have time to do a little relieving for the "free, white and native born" patriots asking for a chance to live.

## Farm Loss in Representation

**A** CHANGE in the reapportionment of representatives in congress has been agitated for many years and, apparently, will not be delayed much longer. The constitution requires reapportionment must be made every ten years. It has not been made for nearly twenty years. As a result, some states are underrepresented.

Just how a realignment would affect the agricultural states at this time is not difficult to analyze. As the manufacturing states, such as Michigan and Pennsylvania, increase in urban population, their representation will increase, while the trend away from the farm states will cause a resultant decrease. The manufacturing and coastal states are filling up rapidly with aliens, who,

## Up for Radio Commissioner



C. M. JANSKY

Above is a picture of the man nominated to succeed Sam Pickard on the Federal Radio commission as commissioner from the fourth zone. Mr. Jansky was formerly an associate professor in radio engineering at the University of Minnesota. The senate failed to confirm his nomination by Coolidge but it is thought Pres. Hoover will re-nominate him.

as soon as they become naturalized, become voters. This class of voters, as a rule, has nothing in common with the farming sections and their representative in congress will express their views and sentiments in national legislation.

The framers of the constitution could not foresee this condition when this section of the constitution was written. There are sections of the industrial east where the voting strength of a single city is greater than several of the western agricultural states combined. These cities are largely populated with aliens who do not speak our language, and know nothing of our ideals of government. Even those unnaturalized aliens, who do not vote, are numbered in the census, and will have considerable to do with the increased representation from those states.

Unless a great trend back to the farm develops in the next decade, the agricultural states will be a small voice, indeed, in the nation's affairs.

## A New Service for Our Readers

On page 3 of this issue are printed three Business Reply Postal Cards. These are for your convenience in answering advertisements or writing to WCFL Radio Magazine for information. No postage is required.

---

# The Art and Practice of Farming

---

## Plugging the Farm Leaks

WHILE many farmers and friends of the farmer look upon relief for agriculture through legislative action and more scientific methods of farming as rather plausible means of attaining the end, some of the more critically-minded are placing their high bets on another line. They have the notion that avoiding waste of valuable by-products is one of the best ways of bringing prosperity to the harrassed yeoman. The farmer's salvation may come through skim milk, corn cobs, corn stalks, oat hulls and straw stacks. Of course some of these materials can be used as feed and some have a bit of value in being left on the ground to rot, but when better used they return a larger profit.

One who believes that the wise use of these waste products is going to revolutionize farming is Dr. Rudolf A. Clemen, assistant director of the livestock bureau of Armour & Company. Dr. Clemen sees us as the heirs of three industrial revolutions—the early industrial revolution, the electrical and the chemical revolutions.

“While the older industrial revolution started with the teakettle and the electrical revolution with the Leyden jar, the new revolution is starting with the test tube. It is a chemical revolution.

“Every year there is produced in the United States about 25 billion pounds of skim milk. This has a casein content nearly as large as the butterfat content, yet America produces only about 15 million pounds of casein. Skim milk has a milk sugar content that is greater than the butterfat content of whole milk. However, this country produces only about three million pounds of milk sugar. Casein is a colloid, and in reaction with other chemicals it forms substances that can be used for various purposes from coating paper to the manufacture of buttons and fountain pens.

“Our horn-rimmed glasses, but for a trick of fate, might have been in our breakfast coffee.

“Waste straw is an important raw material. More than fifty separate elements have been isolated from straw oil. Experimentors in laboratories are extracting 1,600 pounds of useful products from each ton of straw which, if touched by a match, would yield only 40 pounds of ashes.

“Furfural can be produced from corn cobs and oat hulls. At Cedar Rapids, Ia., the only plant in the world makes 5,000 pounds of furfural daily. It is an established industry. The cobs in the corn belt make possible the production of five times as much furfural as there is in by-product coal tar in the United States. Furfural is an aldehyde, and it is stated that it will function as formaldehyde, a statement of much interest to many sufferers from prohibition. Also we can embalm with furfural and put it in automobile engines to stop knocking.”

The recent opening at Danville, Ill., of a mill for the making of print paper from cornstalks brings to the front the important fact that the stalks in the corn belt are more than sufficient to supply all the paper the

United States uses in a year. Another use for cornstalks is in the artificial silk industry. Wall board is now being made from cornstalks and the manufacture will shortly be carried on commercially.

Wheat straws have been subjected to destructive distillation with the idea of making a gas that can be used on the farm for light, heat and power. Beet pulp, now prepared for cattle feed, is another farm waste that has come into its economic place.

The tremendous gains that will come to the farming business through stopping these wasteful leaks may not be all that is required, but no one will deny that they will bring more money to the farmer and that is always something to be wished in a country where so much of trade and prosperity depends upon the buying power of the agriculturist.

---

## Explaining the Farmer's Plight

POSSIBLE light on the farmer's woe and its cause is shed by a recognized authority on advertising, who advances the novel theory that in earlier years the farmer was permitted to keep more of what he earned than he does now. Being more isolated from the lure of salesmen and the seductions of the advertiser, he had fewer opportunities of getting rid of the usufruct of sweat and toil. In a word, he was more prosperous then because he bought less and saved more. Perhaps not so many lusted for his coin or tried to trade him out it.

A violent change has come. The farmer and his city cousin have been completely mixed in a whirlwind of automobiles, radios, telephones, movies, travel, airplanes, fine raiment and the other great blessings of modern life. The farmer has been discovered by the vast army of manufacturers and merchants who sell exciting things. His money looks awful good to them. Advertising pages of farm papers have educated the farm family up to all the fripperies of urban living.

Not only the autos and the other things mentioned are in the modern farmer's bill of rights, but, in addition, he wants beautiful houses and furniture, carpets and inlaid linoleums, pianos and phonographs, electric lights and heating plants. His family goes in strong for higher education, and the seashore resorts call to the landlocked ruralist. More wants has the farmer of today, and his family wants even more than he does. And they get them, too. They stretch their income till it hurts—just like city folks—in an effort to make it cover the gaudy non-essentials even if it fails to fully cover some of the essentials.

With all of the industries and all of the stores in town after the same farmer's dollar and with advertising effort and selling speeded up accordingly, Uncle Ezra on his eighty acres finds it hard to keep a little cash laid by in the old family sock. Every day or so some joy-promoting device comes along to deplete his roll and to make his plight more acute.

In slow-going salesmen of farm (Continued on page 43)





# AMERICAN WATCHES

*Created for  
the Needs of American Life*

Jewelers have been asked . . . "Why do you feature American Watches" . . . And the answer is important to everyone who ever contemplates the purchase of a watch.

Jewelers urge American watches because they are created for America. For American needs. To keep time accurately, faithfully, for a nation of people who place high value upon time.

To such a people they cannot offer watches originally and primarily created for the more leisurely tempo of foreign life, where things do not move with

American speed, where time hasn't American importance. Ask any American business man who has been abroad.

Jewelers everywhere offer a handsome array of American watches. So beautiful they compete with any watches in the world, and marvelous timekeepers as well. All are guaranteed with true American integrity. All can be repaired quickly should accident occur.

Elgin has been an approved American timepiece for years . . . truly the watchword for elegance and efficiency.

## TWO FAMOUS ELGIN MODELS



A handsome strap watch for men, 15-jewel movement fitted in a 14k white gold filled, engraved and oxidized case. Special dial with plated figures selected to harmonize with the case. Price, \$40.



A woman's dainty wrist watch, 15-jewel movement fitted in a 14k white gold filled case with raised figure dial. Oval dial opening. Price, \$45.

# ELGIN NATIONAL WATCH CO.

ELGIN, U. S. A.

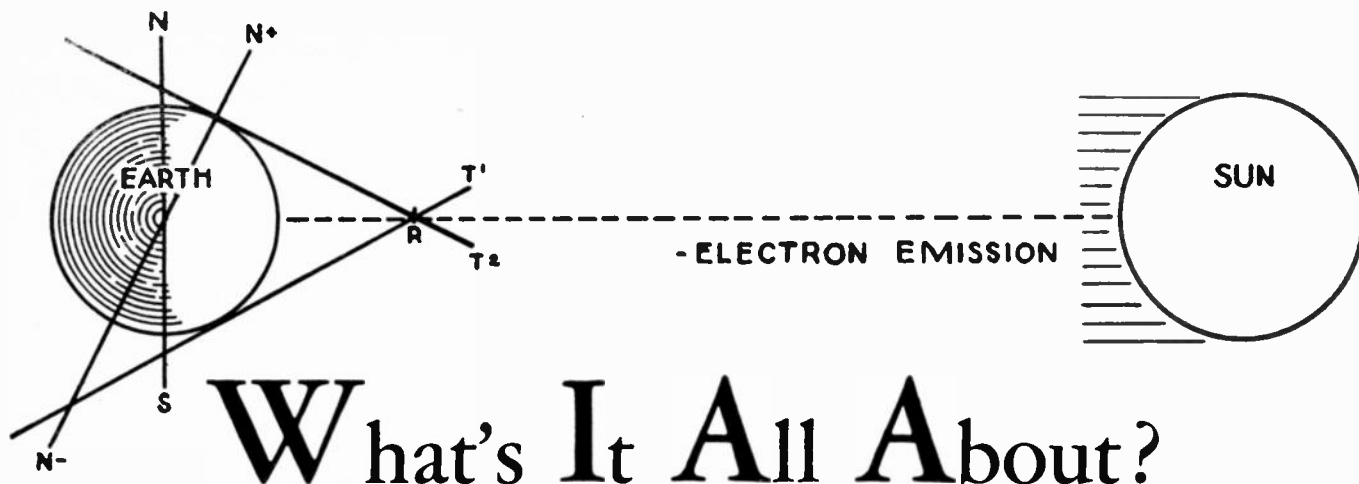

# What's It All About?

*Some Comment on Einstein's New Theory*

By VIRGIL A. SCHOENBERG

**F**ROM the meagre reports which are available at this time on Prof. Einstein's newest theory, the following is a layman's conception of what it is all about without going into mathematical calculations:

It is accepted as fact by practically all physicists and engineers today that all matter and gases possess electrons. Every atom of matter is charged with minute particles of negative electricity which are called electrons. All atoms of substance that go into the composition of the earth are loaded with electrons. When an electron is detached from the atom of matter with which it has been associated it shows none of the properties of ordinary matter. It does not react chemically with other electrons to produce some new substance. And all electrons are similar no matter from what type of atom they have been extracted.

All electrons are of the same kind, or polarity, and they are the smallest possible quantity of negative electricity.

The structure of the atom itself, regardless of what it may be, is always electrically positive. In the normal atom there are just enough electrons to neutralize the positive charge of the atom itself. The normal atom acts like an uncharged body; not because it has no electrical charge associated with it, but because it has just as much negative charge as it has positive charge.

If one electron is removed from the atom by some means or other the balance is destroyed; that is, an excess of positive charge exists in the atom, and the atom is positively charged, the electron which has been removed from the atom constituting a negative charge. A positively charged body, therefore, is one which has been deprived of some of its normal number of electrons. A negatively charged body is one which has acquired more than its normal number of electrons.

Thus, if a piece of sealing wax is rubbed with dry flannel, the wax becomes negatively charged and the flannel becomes positively charged. The friction between the wax and the flannel must have rubbed some of the electrons off of the flannel molecules and left them on the wax.

If a light substance, such as a pith ball, is touched to a charged body it becomes charged with electricity of the same polarity as that of the body itself. As like charges repel one another, the pith ball will be repelled

from the charged body. By experiment it will be found that the repulsive force between the pith ball and the original charge exists at a considerable distance between the two. It is obvious then that the space surrounding a charged body is evidently under some kind of strain which enables it to act upon a charged body with a force either attractive or repulsive, according to the relative polarities of the two charges. This space is what constitutes an electric field, sometimes called an electrostatic field. Thus, an electron in motion constitutes an electric current. Then, as all matter constituting the earth is electrically charged, the space surrounding the earth constitutes an electric field.

The air surrounding the earth is composed of five constituents; namely, nitrogen, oxygen, argon, water (as a vapor), and carbon dioxide, each possessing electrons. The air's greatest density is at sea level, gradually diminishing in height until it becomes exceedingly rare.

The sun's rays possess many electrons and in their approach to the earth they pass first through the rarified area, then down to the earth's surface. As these rays of light travel at a certain speed there is, therefore, a friction set up in their descent and, again, as like poles repel and unlike poles attract, it is obvious that the earth's potential would be positive and the sun's emission negative. If this is true, then, perhaps the earth's rotation may be solved. If the earth is surrounded by a strong magnetic field, it being of one polarity and the sun's emission of another, then it must act as an armature in a motor.

Let's see how this works out graphically. Suppose we draw a circle to represent the earth, and through its center draw a line vertically, marked N S, and at a point equal to its radius make a point R and then draw two lines tangent to the circle as shown, marked T<sup>1</sup> and T<sup>2</sup>, and then draw a line through the center, bisecting the tangent line T<sup>1</sup> where it touches the circle and mark it N+ and S-. Then, at a distance, draw another circle to represent the sun and a series of dashes to represent the sun's negative emission as shown. On examination we will be surprised to find that the line N+ and S- is in an angular position to equal the true north and south poles, also indicating the angle of the earth's inclination toward the sun. As explained, like bodies repel and unlike bodies attract

(Continued on page 49)

## WCFL on Air with Television

(Continued from page 14)

air was another problem that had to be overcome. The problem of proper reception entered and it has been solved to a marked degree of success, which is indicated by the number of reports we have received on our broadcasts.

"It was also necessary to design and construct a complete unit embodying all of the necessary equipment required to be able to broadcast and receive television and movies successfully. Now with all of this done along with the successful broadcast of movies, and with thousands of dollars invested by broadcast stations and by you in receiving equipment; and with fair television just around the corner, we are all required to stand by awaiting the decision of the Federal Radio commission.

"May I suggest again that those of you who are interested in the advancement of science to communicate with WCFL, engineering department, Navy Pier, Chicago, or 623 South Wabash Avenue, Chicago.

"Those of you who are interested in television and desire to become familiar with some of its workings, may I suggest that you secure a copy of WCFL Radio Magazine, now appearing on the news stands. The price is 35c. You will find many interesting articles pertaining to television. Should you be unable to secure a copy send 35c to WCFL Radio Magazine, 623 South Wabash Avenue, Chicago, and a copy will be immediately mailed you.

"To all members of WCFL Television Club, now numbering over 300, we suggest that you communicate your reactions to WCFL, engineering department, Navy Pier, Chicago.

"Hoping we will again be able to address you and provide you with more television broadcasts in the near future, we are signing off now."

### The Farmers' Plight

(Continued from page 40)

machinery and other things that pertain to work, bring their sales talks up to the minute. When the salesman convinces the down-trodden farmer that with some new equipment he can make more money and buy luxuries faster, it is easy to get his name on the dotted line.

The familiar argument that the first requisite of the farmer who wants to be saved is to maintain a high standard of living, at times is a bit wearisome. Like other fine theories, it may be overworked. Of course, a reasonable amount of joy riding is good for most any farmer. Still it is always possible to go too fast.

### Use the Mails Without Cost

Only members of Congress and other government officials are supposed to be able to use the U. S. mails without paying postage. However, WCFL Radio Magazine has made a clever adaptation of a recent postal regulation which makes it possible for you to enjoy the privilege of using the mails without paying postage. See the Business Reply Postal Cards on page 3.

### Warning

Dentist: "Do you bleed easily?"

Patient: "No, I'm known as a tightwad."



# BANDPASS

## FILTER Effects

**FLAT-TOP** tuning

**10 KC.** selectivity

**PERFECT** tone

**T**HE Master Hi-Q 29 is the only circuit permitting the use of shield-grid tubes at their maximum amplifying ability.

So remarkable has been the performance of this receiver that not only are professional men everywhere building it, but the engineers of nearly a score of the foremost radio companies have purchased it either for personal use or for laboratory experiment.

Due to the characteristics of loosely tuned circuits, each of the doubly tuned radio-frequency transformers used in the Hi-Q '29 actually constitutes a "band-pass filter", the effect of which is shown in the graph below. Space does not permit full description of the many advantages thus gained but the informed radio man should quickly grasp the results shown in the exclusive Hi-Q "flat-top" response curve.

The sum total of Hi-Q '29 design is a finer degree of both sensitivity and selectivity than has ever been known before with the added advantages of tone quality which experts admit is nothing short of epoch-making.

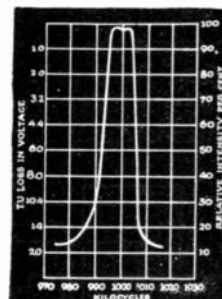

It will pay you to write for our 80-page illustrated book on Hi-Q "Band - Pass Tuning" and construction details of the four Hi-Q models. Price is 25c. Use the coupon.

# Hi-Q 29

HAMMARLUND-ROBERTS, INC.,  
1182 M Broadway, New York.

Enclosed find 25c for my copy of your book on Hi-Q Band Pass Filter Circuits and full construction details on your four Hi-Q models.

NAME .....

ADDRESS .....

# The Screen-Grid Find-All Four

*A Modern Four-Tube Hookup That Will Bring Delight to the Radio Fan*

By H. G. CISIN

**B**Y applying the screen grid tube correctly, it is possible to make a four-tube set do the work of a six- or a seven-tube receiver. After considerable research and experimentation the Screen-Grid Find-All Four was developed. This uses a screen-grid tube in the r.f. stage, a regenerative detector and two stages of audio frequency amplification. In this circuit, the screen grid tube is used so effectively that it enables this little four-tube tuned r.f. set to bring in stations hard to get with a standard factory-built seven-tube super-heterodyne. On local broadcasting, the volume is extraordinary. Even stations 1,000 miles distant are brought in very often with the volume of locals. This receiver uses fewer tubes and less apparatus than the average set, but delivers more volume and has greater sensitivity. It has less wiring and is easier to assemble than the ordinary tuned radio frequency receiver. Furthermore it uses standard parts throughout.

In brief, the Screen-Grid Find-All Four is a receiver of unusual merit, capable of bringing in stations from coast to coast and because of its unique performance, it should become one of the outstanding receivers of the 1929 radio season. In addition to the advantages mentioned above, this receiver has beautiful tone quality and can be built for approximately \$50.

The r.f. stage of the Screen-Grid Find-All Four is tuned by a .0005 mfd. Hammarlund condenser. A similar condenser tunes the detector. The antenna coupler is a standard Aero coil. Coupling between the screen-grid tube and the regenerative detector is accomplished by means of an Aero coil designed for

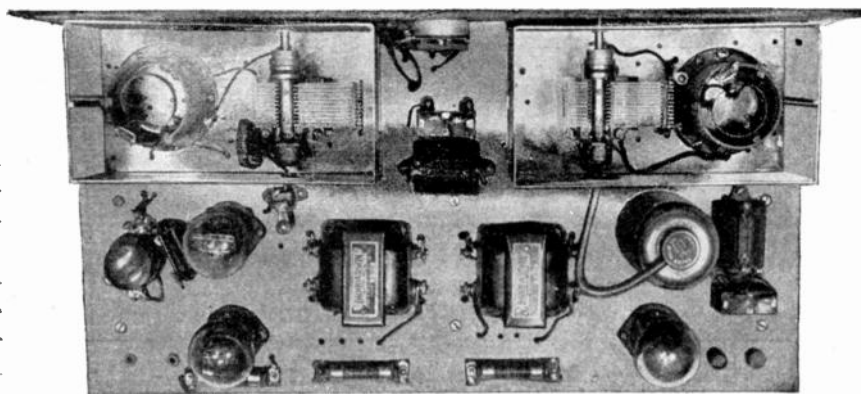

Back of Panel of the Find-All Four

the 222-type tube. An Aero 3-circuit tuner may be substituted in place of the screen-grid coil. Each Aero coil, together with its tuning condenser is shielded by means of a Silver-Marshall aluminum shield. The Gold Seal screen-grid tube is shielded separately by means of a standard tube shield. The connection from the stator of condenser (5) to the cap (control grid) of the shield grid tube, is also shielded. Due to the internal shielding by the screen (outer) grid, no neutralization of plate to grid capacity is necessary. The operation of the receiver is characterized by extreme stability.

A Yaxley 75-ohm rheostat across the primary of the antenna coupler acts as a volume control. This may be supplemented, if desired by an Electrad Tonatrol. Regeneration is controlled by means of a Royalty rheostat, connected in shunt across the tickler coil. Since the latter is rotatable, this provides an additional means of controlling regeneration. A Durham metallized-resistor grid-leak is used with a Polymet grid condenser. The circuit design calls for Silver-Marshall r.f. chokes, by-passed by Polymet fixed condensers. The audio portion of the circuit utilizes two Thordarson R-300 transformers. Four Eby sockets are required and the Amplion loud speaker is connected by means of the new type Yaxley insulated tip jacks. Anperites are used to regulate the filament current to the detector and the two audio tubes. Eby binding posts are used for aerial and ground and a Yaxley cable connector provides a convenient link between the B and C supply and the receiver. A tapped resistor reduces the filament voltage on the screen-grid tube to the required 3.3 volts. The control grid bias is obtained by the use of the voltage drop in this resistor.

Specifications call for a Gold Seal screen-grid tube, two Gold

(Continued on page 59)

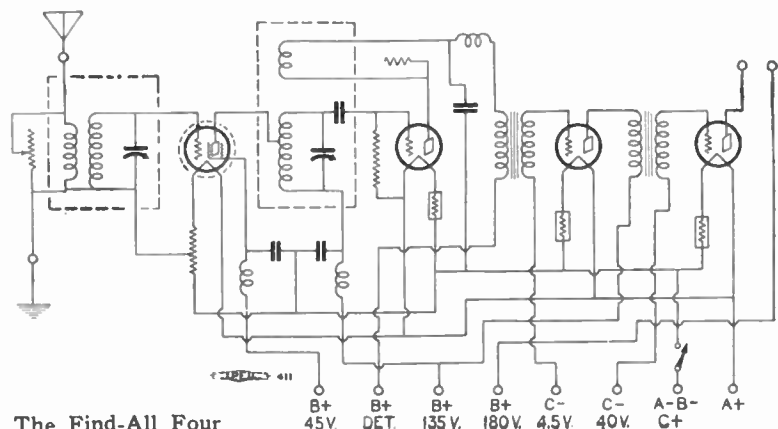

The Find-All Four

# I Will Train You at Home to Fill a Big-Pay Radio Job

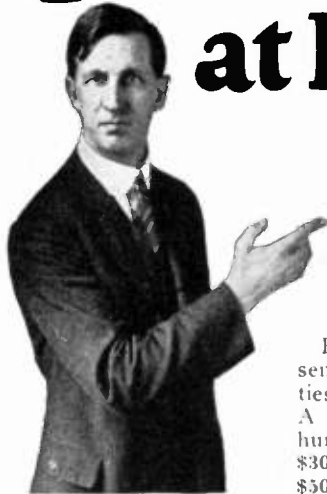

## Here's the PROOF



Made \$185 in  
Three Weeks'  
Spare Time

"I have met with continued success. For instance, recently I realized a profit of \$185 in three weeks, \$1.50 an hour. I have been making good money almost from the time I enrolled. The N. R. I. has put me on the solid road to success."—Peter J. Dunn, 901 N. Monroe St., Baltimore, Md.

Made \$588 in One Month

"The training I received from you has done me a world of good. Some time ago, during one of our busy months, I am servicing all makes of Radio receiving sets. My boss is highly pleased with my work since I have been able to handle our entire output of sets here alone."—Herbert Reese, 2215 So. B St., Elwood, Ind.



Earns Price of Course in  
One Week Spare Time

"I have been so busy with Radio work that I have not had time to study. The other week, in spare time, I earned enough to pay for my course. I have more work than I can do. Recently I made enough money in one month spare time to pay for a \$375 beautiful console all-electric Radio. When I enrolled I did not know the difference between a rheostat and a coil. Now I am making all kinds of money."—Earle Cummins, 18 Webster St., Haverhill, Mass.

If you are earning a penny less than \$50 a week, send for my book of information on the opportunities in Radio. It's FREE. Clip the coupon NOW. A flood of gold is pouring into Radio, creating hundreds of big pay jobs. Why go along at \$25, \$30 or \$45 a week when the good jobs in Radio pay \$50, \$75 and up to \$250. My book "Rich Rewards in Radio" gives full information on these big jobs and explains how you can quickly become a Radio Expert through my practical home-study training.

### Salaries of \$50 to \$250 a Week Not Unusual

Radio needs trained men. The amazing growth of the Radio business has astounded the world. In a few short years three hundred thousand jobs have been created. And the biggest growth of Radio is still to come. That's why salaries of \$50 to \$250 a week are not unusual. Radio simply hasn't got nearly the number of thoroughly trained men it needs. Study Radio and after only a short time land yourself a REAL job with a REAL future.

### You Can Learn Quickly and Easily in Spare Time

Hundreds of N. R. I. trained men are today making big money—holding down big jobs—in the Radio field. You, too, can become a Radio Expert. Our tested, clear training makes it easy for you to learn. You can stay home, hold your job, and learn quickly in your spare time. Lack of high school education or experience is no drawback. You can read and write. That's enough.

### Many Earn \$15, \$20, \$30 Weekly on the Side While Learning

My radio course is the famous course "that pays for itself." I teach you to begin making money almost the day you enroll. My new, practical method makes this possible. I give you SIX BIG OUTFITS of Radio parts with by course. You are taught to build practically every type of receiving set known. M. E. Sullivan, 412 73rd Street, Brooklyn, N. Y., writes: "I made \$720 while studying." G. W. Page, 1807 21st Avenue, Nashville, Tenn., "I picked up \$935 in my spare time while studying."

### Your Money Back If Not Satisfied

My course fits you for all lines—manufacturing, selling, servicing sets, in business for yourself, operating on board ship or in a broadcasting station—and many others. I back up my training with a signed agreement to refund every penny of your money if, after completion, you are not satisfied with the lessons and instructions received.

### ACT NOW—64 Page Book Is FREE

Send for this big book of Radio information. It won't cost you a penny. It has put hundreds of fellows on the road to bigger pay and success. Get it. Investigate. See what Radio has to offer you, and how my Employment Department helps you get into Radio after you graduate. Clip or tear out the coupon and mail it RIGHT NOW.

J. E. SMITH, President,  
Dept. 9-R99  
National Radio Institute,  
Washington, D. C.



You can build  
100 circuits with  
the six big outfits  
of Radio parts  
I give you

3 of the 100 you  
can build

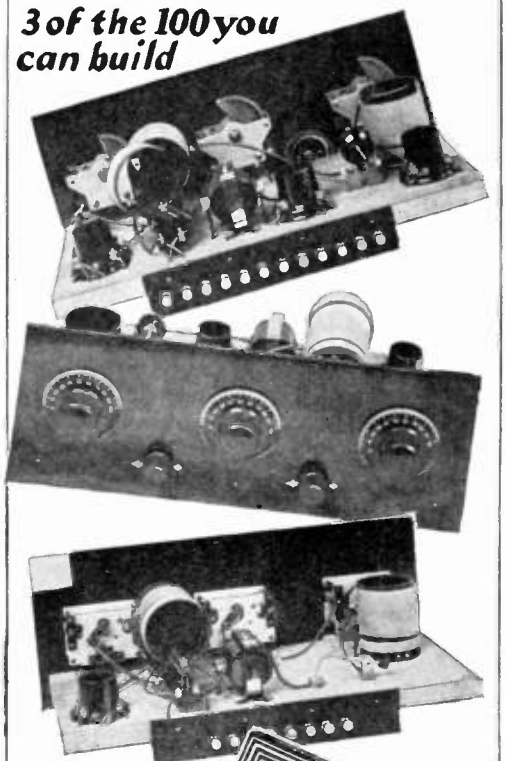

Find out quick  
about this  
practical way  
to big pay

### Mail This FREE COUPON Today

J. E. SMITH, President,  
Dept. 9-R99, National Radio Institute,  
Washington, D. C.

Dear Mr. Smith: Kindly send me your big book "Rich Rewards in Radio," giving information on the big-money opportunities in Radio and your practical method of teaching with six big outfits. I understand this book is free, and that this places me under no obligation whatever.

Name ..... Age .....

Address .....

City ..... State .....

Occupation .....

**Employment Service to all Graduates**  
**Originators of Radio Home Study Training**

# An Interesting Screen-Grid Short Wave Converter

By  
PERRY S. GRAFFAM

AS the one stage r.f. with regenerative detector rapidly became the outstanding circuit arrangement in home-built receivers during the great broadcast building era, so has a similar circuit won over the short-wave field. With this type of set just beginning to be appreciated, vast numbers of parts have been sold for these receivers.

The circuit used in short waves, however, uses an untuned input rather than a tuned antenna circuit, and in this way, differs from the accepted broadcast practice. The screen-grid tube serves several purposes. It permits the use of an antenna of any length without adjustment; it gives some amplification to the incoming signal; and, most important of all, it prevents squeals from going out to the neighboring sets. This latter point may not impress some of our recent listeners, but those who listened in two or more years ago will never forget the so-called "blooming" that characterized every evening's entertainment in those days. With the great increase in the number of short-wave receivers, this same condition will occur in those frequencies unless a blocking tube is used to prevent regeneration radiation.

A general impression among many people, not familiar with short waves, is that a completely new receiver must be built to get the myriad programs on the air down there. This is not the case, however. The short-wave receiver differs only in the tuning section. From the detector on, the arrangement is identical with any broadcast receiver.

A simple converter which will permit one to use the most popular of short-wave circuits, in connection with the usual broadcast receiver, is described in the following. After completing it, one merely has to remove the detector tube and insert the plug of the converter in its place. The detector tube is then placed in the converter.

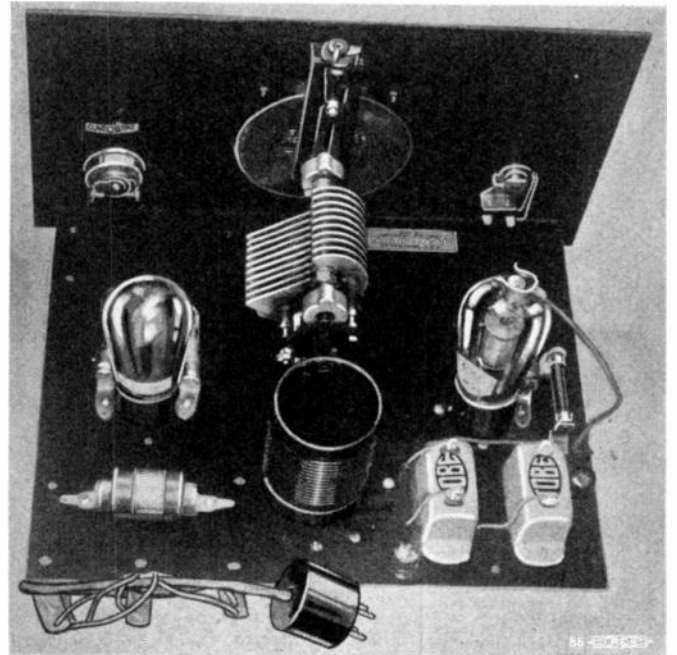
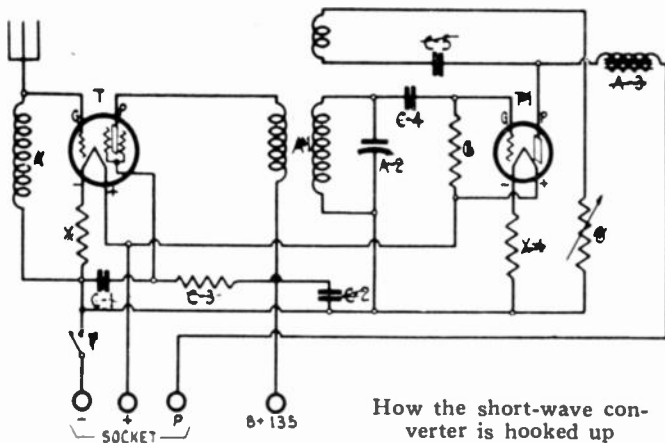

Back of panel view of converter

and one can then tune-in virtually around the world.

It hardly seems necessary to go into any specific structural details, for the accompanying simplified and schematic diagrams tell the whole story. Only few parts are needed, and their placement is indicated. The list of parts follows:

1 National short-wave kit, consisting of front and sub-panels, set of plug-in coils, tuning condenser and choke. (These parts may be purchased separately if desired.)

- 1 Clarostat grid leak.
- 1 Tobe 8 meg. tipon leak.
- 2 Tobe .5 mfd. by-pass condensers.
- 1 Tobe 2000 ohm Veritas resistance.
- 1 Tobe .00025 vacuum condenser.
- 1 Tobe .001 vacuum condenser.
- 1 622 Amperite.
- 1 1-A Amperite.
- 1 Yaxley switch.

Any discarded tube may be used for the plug-in socket base. The glass bulb and stem should be broken, and the other material in the base cleaned out. The four brass tips, embedded in the base, will come into view, and the necessary connecting leads should be soldered to them. The plug may then be filled with wax. This takes care of three of the four external leads to the set. The 135-volt connection is made to a binding post at the rear of the unit.

Readers have perhaps little idea of the radio sport that lies in wait for them down on the shorter waves. Up until this year, there was so little to listen to except

code that a set hardly seemed worth while; but now any number of stations are broadcasting on these wave lengths. Stations all over the North American continent are heard during daylight hours, some of which cannot be heard even at night time on a good broadcast receiver.

However, the real thrill comes with a transoceanic reception. 5SW, the British Broadcasting company's station at Chelmsford, England, can be picked up from 5 on until to 7 p. m., eastern standard time, and under favorable conditions may be brought up to loud speaker strength. This station usually closes with an hour of dance music, and when you can clearly hear the music, dancers' voices and the hand clapping for encores from the Savoy hotel in London, right from your own loud speaker, you are getting real radio thrills.

Now Germany is just completing a powerful short-wave station with which it is expected to broadcast excellent programs to the whole world. A particularly strong station is the one in Eindhoven, Holland, which puts on regular programs for use in the British colonies and other remote points. This station is more widely heard than any other short-wave station in the world, according to many reports. The thoughts of getting distant places like these usually conjure up visions of super-priced receivers using fourteen tubes, and totally out of the reach of the average fan to build, buy or operate. However, thanks to the gift of short waves, this is not the case. Just build up the little simple unit described herewith; connect it to your present radiocast receiver; and, then, like Monte Cristo, you can say, "The World is mine!"

### All-Electric Jr. Hi-Q 29

(Continued from page 23)

necessitate individual tube shields to isolate the tube elements from the other apparatus. To avoid the use of these additional shields the tubes are placed between the stage-shields in such a position that the control-grid and plate leads are very short and all coupling from the tube elements to other parts of the circuit is prevented.

Control of volume is accomplished by the use of a 3000-ohm specially-tapered potentiometer connected between the antenna and ground. The slider of this instrument is connected to the grid of the antenna coupling tube, thus allowing any desired part of the signal voltage to be impressed on the grid. This results in a smooth continuous control of volume from a whisper to the full power output of the set. The special tapering of the resistance unit prevents criticalness at the lower volume settings.

In the complete a.c. operated model the A, B and C power apparatus is mounted directly on the steel chassis, making the receiver an entirely self-contained unit ready to plug in the light socket.

Full directions for wiring the New Hammarlund-Roberts All-Electric Junior Hi-Q 29 will be sent upon request to readers of WCFL Radio Magazine. Just turn to page 3 and fill in the Business Reply Postal Card printed there. No stamp is needed, and it is self-addressed. Something new—try it.

No postage is required to answer advertisements appearing in this issue of WCFL Radio Magazine. Merely fill in and mail one of the Business Reply Postal Cards printed on page 3 and the information will be sent promptly. These cards require no postage.

Did you hear about the father who called his son Arch because he always needed support?—*Royal Arcanum Bulletin.*



Model 72  
\$167.50  
Less Tubes

## Majestic

**MIGHTY MONARCH OF THE AIR**

The new and greater Majestics are in the leading radio stores everywhere.  
See and hear the Majestic today. You will be delighted.

**GRIGSBY-GRUNOW CO.**  
5801 Dickens Avenue Chicago, Illinois

## Be Warned

**YOU** can use second rate condensers in your **SHORT WAVE RECEIVER**—**BUT**, remember the fellow blowing the trombone who complained, "I blow it in so nize und it comes out so rotten."

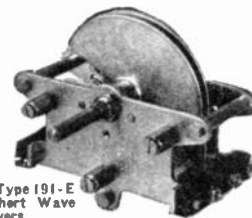

Taper Plate Type 191-E  
Ideal for Short Wave  
Receivers.

**HIGH FREQUENCY WAVES** will go into your circuit readily enough, but the results may not be so good.

**CARDWELL TAPER PLATE** Condensers have heavy, die cast plates, hold their calibration, don't vibrate, and will give the stability so necessary in the **SHORT WAVE RECEIVING CIRCUIT.**

**YOU'RE NOT GAMBLING WHEN YOU CHOOSE A CARDWELL.**

## CARDWELL CONDENSERS

VARIABLE — FIXED  
TRANSMITTING — RECEIVING

*Write for Literature*

**The Allen D. Cardwell Mfg. Corp.**  
81 Prospect St., Brooklyn, New York

---

# Letters That Reach the Editorial Desk

---

**E**DITORIAL work is not all drudgery, even when done by an associate editor.\* There is more to it than merely writing articles, revising the work of others, dealing with photographers and engravers, reading proof, making up the pages, cussing printers and many other routine chores. There are high spots or perhaps bright spots in the life of even the most harried editor that chase away his drab-mindedness and lead him into a kinder and better fellowship with himself and others. He has secret joy. He likes to get letters from his readers, to answer them and to do any favor in the way of giving information that he knows enough to do. Even complaints are gladly heard and attended to. Next to being praised for the publication he puts forth, the editor enjoys being quarreled with, shown up as a bunk shooter and ignoramus, providing always the reader gives him a chance to reform.

WCFL Radio Magazine readers, as well as station listeners, are getting the letter writing habit nicely. That makes one editor love them and also his job.

Walter P. Kagel of South Chicago is only one of many who writes in complaining of the trouble he has in buying a copy of this magazine and wanting help. He was made happy by receiving a subscription blank. Since he also wanted the radio course and took the trouble to say that he enjoys immensely "the wonderful programs you are putting out," he got a prompt reply and 100 percent co-operation.

## RADIO COMFORT FOR THE BLIND

Roy D. Knox of Grand Haven, Mich., writes that lately their radio does not perform the way it should and they do not get to listen in as they want to do. He and his wife are blind and are dependent for most of their enjoyment upon the radio. They also made inquiries about tubes and oil heaters.

Signing himself "Yours Militantly," Romuald Fox, secretary of the Amateur Protective association with headquarters at Valley Falls, Kan., writes Mr. Nockels enlisting in the battle against the Radio Trust: "You see we want ultimately to get what belongs to us and dislodge the intruder. We can help your organization and you can help us." This is the spirit of true co-operation. Mr. Fox was offered all the help WCFL is capable of rendering the common cause. However, the fact that the reply to his letter was signed by the business manager, aroused the ire of Mr. Fox, and he sent it right back with this penned at the bottom: "I did not write to the business manager but to Mr. Nockels and expect him to answer, not some \$\$ and ¢¢ man."

An embattled farmer in the fight against the Radio Trust is Andrew O. Huus of Makoti, N. D. In his letter he avows his wrath against the powers and says: "I trust you will be able to broadcast during the evenings with more power, as this is the only time most of us get any good out of the radio."

Elwood H. Laudemberger, 511 Parsons St., Easton,

Pa., writes for a subscription blank to become one of the many new thousands of readers of WCFL Radio Magazine. All that need be said is that Mr. Laudemberger's conduct speaks for itself.

William E. Brownell conducts "the only electric shop in Elkhart, Ind., that has signed a contract with the local Union of Electrical Workers that gives them satisfactory wages and working conditions." Mr. Brownell is proud enough to write about it. He is also interested in radio opportunities in South America, but that is a little too far off for us to render help.

## CHICAGO WOMAN GREETES FARMERS

"What we need is more such friends," was the reply to Mrs. Marie Wiening, 7202 South Western Avenue, who in renewing her subscription says how thankful she is to the Chicago Federation of Labor for broadcasting its programs of songs and other music. She also sends her greetings to the farmers who co-operate. Not to be overlooked were some lines in German, which translated read as follows: "All good gifts, everything we have comes, my God, from Thee. Hearty thanks, therefore Amen."

What could be more interesting than the letter of J. H. Higbee, R. R. 2, Parkston, S. D.: "I recently received the magazine and am delighted with it, especially with the television articles and Farmers union section. In one article you speak of flashes of light and shifting of same rapidly. Now, years ago, I couldn't help noticing that when a windmill was running fast you could not see a spoke or fan, but should you bat your eyes right quickly you could see plainly every spoke or panel it contained. I observed the same with a fast running buggy wheel or wheels on a locomotive. So from these I always thought that moving pictures were taken while things were moving and therefore had to be focused out the same way. Am I right?" Mr. Higbee is proud of his acquaintance with Brothers Milo Reno of Iowa, Huff of Kansas and Charles S. Barrett, as well as other prominent men in the Farmers union.

The fact that Mr. Higbee was unable to see the blades in the rapidly revolving windmill is due to the slowness of the eye. When the eyes are closed and suddenly opened just for one brief instant the eyes vision things exactly as they are. Therefore he was able to see the blades in the fan. In watching television broadcasting apparatus one notes similar things.

While moving pictures are made of moving objects, the pictures are all still pictures. Sixteen separate and distinct pictures are taken each second. When these are presented in a projector each picture comes to a complete stop before the lens and then moves on to make room for the following picture, sixteen being presented each second. The eye is so slow that it does not detect this but gets the impression of moving objects.

Many letters come from Labor union officials and from publishers of labor papers, who are keenly interested in some feature in WCFL Radio Magazine. The Union Labor Bulletin of Little

(Continued on page 52)

\*Detail editorial work on WCFL Radio Magazine is done by a man of wide editorial and magazine experience, under the general supervision of E. N. Nockels.



## What's It All About?

(Continued from page 42)

and as the north pole is the strongest positive potential and the sun's emission negative they are attracted. And as the S pole is negative they repel, the position thus being balanced. It will be interesting to know that the angle  $R-T^1-T^2$  is the same as that of a prism used to break up or separate the light rays into various colors or frequencies. It may then be assumed that the point R be called neutral.

If these things are true, then this may explain why tons of sap rise in the trees each spring and recede each fall. It is known that sap is positive and as the sun's emission is negative they are attracted. When that portion of the earth is in a position to receive its quota of electron emission from the sun, the sap being of unlike polarity, tends to rise and meet the negative emission from the sun. Again as in the electron theory, like poles repel and unlike poles attract. This perhaps explains why the foliage in the tropics and semi-tropics is always green, as they are always in a position to receive their necessary quota of electron emission from the sun, therefore keeping the sap up in the trees.

Perhaps Prof. Einstein is right about his gravity theory. As in all electrically charged bodies, the greatest field of magnetism would be at the earth's surface, or at a point slightly below, the distance varying due to the earth's contour. Then a body would be at its greatest weight at this point. Then, as the strength of an electrical field diminishes in all directions, it is obvious that a body removed from the surface of the earth, where the electrical force of attraction is greatest, will diminish in weight as the distance is increased.

## Do Sky-Scrapers Menace Health?

ONE of the strong points urged in favor of the national practice of putting up tall buildings is not that it affords an easy way of going heavenward but that it tends to delay that inevitable excursion by promoting health. The highest floors are generally the most desirable because people believe that at altitudes the air is freer from smoke and dust.

Now come the joy killers with assertion, by reputable medical authority, that we have allowed our pride in these colossal structures to dull our sense of proportion and judgment. These huge towers are said to be a menace to health, as well as being responsible for street congestion.

It is declared to be no longer sensible to build forty-story structures on the present narrow streets, and health authorities go on to ask what is the sense in bringing hundreds of thousands of people into a particular area to do work that could just as well be done in outlying districts. Employees would probably be more comfortable than they are in pouring into the Loop on surface and elevated trains. That these long rides are often more strenuous than a days work is a common experience; that they are a menace to health in the crowded conditions is the belief of many of our wisest men.

Use the Business Reply Postal Cards on page 3. They are for your convenience. No stamps required.

## Two Raytheon Contributions to TELEVISION for Broadcasting



The new Raytheon Foto-Cell is now in practical operation in many broadcasting stations and experimental laboratories. Supplied in both hard vacuum and gas-filled types—each in two sizes. Special specifications on request.

**Raytheon Foto-Cell**  
for Receiving

Raytheon Kino-Lamp is the first tube developed commercially to work on all types of television receivers. A double plate practically doubles the life of Kino-Lamp. A uniform glow over the entire plate, without the use of mirrors or ground glass, offers unusual reproduction qualities—with a particularly low current drain.

20 m. a. \$7.50  
Raytheon Mfg. Co., Cambridge, Mass.

**Raytheon Kino-Lamp**



## NOT EVERY "VOLTAGE CONTROLLER"

IS A

## RESISTOVOLT

TRADE MARK REGISTERED U. S. PAT. OFF.

Look for the Trade Mark "RESISTOVOLT" for your own Protection



Insist on the genuine "RESISTOVOLT" it is your guarantee

### FIRST in the FIELD—FIRST in SALES!

**RESISTOVOLT**—Automatically checks the excess line voltage which is slowly burning down your tubes from overload. No more blowouts from line "surges" when you have Resistovolt at the current outlet. Acts as fuse in case of short circuit. Banishes line noises caused by electric lights, motors, appliances. All metal, air cooled, Deluxe Model, consumes no current. If your dealer cannot supply, remit to manufacturer or order C. O. D. **\$1.75**

**ANTENNAVOLT**—A combination RESISTOVOLT and LIGHT SOCKET ANTENNA. Gives sharper tuning, minimizes static, greatly enhances reception. All the conveniences, safety, and better appearance of the socket antenna PLUS RESISTOVOLT voltage control protection of tubes and **\$2.25** set.

TELEVISION!!! write for catalogue showing the I. C. A. Television Kits. Assembled in 15 minutes. \$37.50 to \$100.00. Also individual parts: Disks, tubes, motors, amplifiers, etc.

Manufactured and unconditionally guaranteed by  
**INSULINE CORP. OF AMERICA**  
78-80 Cortland St. New York, N. Y.

---

# Some Kind Remarks About Hypocrites

---

AS a rule, the charge of sham, pretense and hypocrisy is reckoned the most damning. After proving the other fellow to be a liar, a thief and a scoundrel, the clinching ignominy is: "He is a hypocrite." For proof, let the editorial pages of our newspapers be offered, also the frenzied denunciations by political orators of their opponents. For good measure may be added the tirades of pulpit whackers, soap boxers and practically the whole fraternity of word-fingers. We find beyond doubt that wicked as sinners are, those most to be despised are the wolves in sheep's clothing.

Blasts against posturing are unfortunately, in many instances, allowed to take the place of logic in support of one's affirmation, if anything is affirmed. It is much more convenient to show that the rascals on the other side are prompted by doubtful motives than it is to make one's own cause as clear as lightning and as convincing as thunder. Perhaps this explains why many of our great leaders and devout thinkers are hopeless addicts to the summer and winter sport of baiting hypocrites.

A notable instance is found in the explosive wrath of the late President Wilson against the House and Senate that overrode his veto of the popular prohibition act. "Miserable hypocrites" raged the executive, "voting to override my veto, many of their cellars stocked with liquors and not believing in prohibition at all," and a lot more phrases belonging to the index expurgatorius.

Stern Puritan Wilson felt it his moral duty to send to perdition the majority of the House and Senate. The President, an earnest soul, could not abide horseplay in the nation's business. He was congenitally disposed to take others, and even himself, too seriously. Wilson's closest friends admit that he was a poor sort of a politician. His handling of most of the matters of state, especially toward the end of his office, disclosed his weakness—he wanted to be consistent, tried to be. But down he went.

On the other hand, the wise boys he had to deal with were strong for safety first. They had sense enough to know that few long remember or care for mere pretending. They also knew that politics is organized to get there. The crowd must be satisfied if sufficient votes are to be gathered. In the face of political necessity, Wilson's anger was impotent. Broken-hearted, he has been years in his grave and not much talked about any more. The boys, or many of them, who understood politics are still hearty. And now some folks are mean enough to suggest that even Wilson, in spite of his costly efforts to appear consistent, was himself not altogether free from the charge of sham. Such is fame.

The general popularity of hypocrite baiting was just recently demonstrated in the Senate of the United States, where to packed galleries Jim Reed, indulging in this pastime, sang his swan song. The gifted senator from Missouri knows all about hypocrites, and he did justice to the subject, speaking with great verve and dramatic effect. We all got an earful about ourselves. The re-

tiring senator, of course, did not have much to say about himself, perhaps due to modesty. Jim has been a successful politician for many, many years and in the Senate for most of that time. Now that he is retiring voluntarily, it would be unkind to hint that he may not always have been as open-faced as a watch and as frank as a child. While he was flaying them, no doubt, some of his enemies snickered considerably, recalling the flirtation that Jim tried to carry on with drys just prior to the Houston convention, with a fervent desire to be looked upon as the "white hope" of the drys against the legions of Al Smith. But then, enemies are always snickering when the great of the nation want to be thunderously serious.

The notion that good people are always sensible and consistent, never tell a lie or play the hypocrite is probably one of the most persistent of current errors. Clamorers for perfect honesty, although they know not what they do, cannot be easily forgiven, because they are really undermining the foundations of many of our most cherished institutions.

Shall wedlock be abandoned or made companionate because in its accomplishment a lot of pleasant lies are passed and promises are made for the flat performance of definite tasks that in most cases will not be carried out, except in remote contingencies?

Marriage and the home are in danger. What is to become of lovenaking, promoted as it is by the mousing of idiotic nothings? Are only those who mean just what they say on the matter of honor and obey, to be allowed to approach the marriage altar? How about the "better or worse" part of the contract and those lines ending "till death do us part?"

Are men to be denied the time honored prerogative of lying to their wives? Are "business appointments" and "club meetings" to exist only in ancient history? Is the male brute no longer to be permitted to bring joy to her eyes by the soothing averment that she is the best wife he ever had and is getting younger and prettier every day?

Such important activities as trade and finance may well view with alarm unreasonable demands for the unflinching truth. Shall sound business, usually assisted by glowing sales talks, be thrown into limbo just because more is promised than can be or will be performed? Shall all the jolly, kidding, story telling and back slapping that does so much good be abolished to satisfy a group of straight-laced moralists, insisting upon the truth, the whole truth and nothing but the truth?

Here is another serious matter. Are we to lose the delights of balls, receptions, bridge parties and the numerous punch bowl orgies because the dear ladies lie shamelessly to one another? What would social life be without clever compliments, though studied and insincere, but oh so good to hear?

In any outcome one has to think of the children. What do sticklers for honesty (Continued on page 65)

## How a Great Store Started

IT usually takes many, many years for a business to build to a point where it assumes leadership in its field. Radio is comparatively in its infancy, yet in Chicago a store has grown to such proportions that it is called the World's Largest Radio store. It is the Chicago Salvage Stock store, located at 509 South State Street, Chicago, Illinois. To be true, before the introduction of radio, this business was in existence retailing any article that could be offered as a genuine bargain. They bought and sold salvage stocks and that is how the name originated.

Then along came radio and its sudden acceptance by the public. Realizing the wonderful future in radio a radio department was immediately installed. The same policy of offering bargains prevailed in the new department and naturally it rapidly progressed. The rest is easy to guess.

Today the Chicago Salvage Stock store occupies its own building given over entirely to radio accessories, parts and sets. Every item known to radio is carried here. On their second floor they have what is called a Radioteria, an original department where patrons wait on themselves and can secure most unusual values as well as hard-to-find radio needs.

The wonderful values that Chicago Salvage Stock store is



Chicago Salvage Stock Store Is a Busy Place

able to offer is directly responsible to their vast buying power. Carload purchases are an every day occurrence and they are constantly on the lookout for exceptional buys.

For those interested in radio needs at lowest prices we will be glad to send them our new 1929 Radio Catalogue, filled with wonderful values. Just mail your request to the Chicago Salvage Stock store at 509 South State Street, Chicago, Illinois, or use the Business Reply Postal Card on page 3 of this issue of WCFL Radio Magazine. This is something new. No stamp is required.

### New Short-Wave Converter

A NEW short-wave converter is now on the market and already in the hands of leading jobbers and dealers, that fits all makes of present radio receivers, both A.C. and D.C. This new product, the Aero-Call, is a complete factory-built short-wave radio-adaptor set that plugs right into the detector socket of any make of radio and transforms the radio set into a modern short-wave receiver.

This new device now makes it both easy and practical to utilize one's radio set for short-wave reception, as the Aero-Call utilizes the power and hook-up of the regular receiver, and all that is required is to pull the detector tube out of the set and plug in the Aero-Call socket whenever short-wave reception is desired.

The whole unit is neat and compact, being completely shielded and housed in an artistic browntone cabinet, with everything out of sight, making a suitable companion for even the most imposing and artistic radio or phonograph cabinet or set.

**Back in  
April  
19 28!**



## CeCo Announced This Type AC 22 Screen Grid Tube

*The five prong tube of the separate heater type operating directly on alternating current*

—now recognized as the most outstandingly successful amplifying tube of the season.

CeCo pioneered—and did its pioneering without the fanfare of trumpets. But it is pleasing to know that an increasing number of radio engineers and experts look with confidence to the CeCo laboratories for each new development in the tube industry . . . a reward not measured in dollars and profits.

Do not miss CeCo's entertaining radio broadcast each Monday evening at 8:30 Eastern time (7:30 Central time) over the Columbia Broadcasting System.

CeCo Mfg. Co., Inc., Providence, R. I.

**CeCo** Radio  
Tubes

# More Than Flights of Fancy

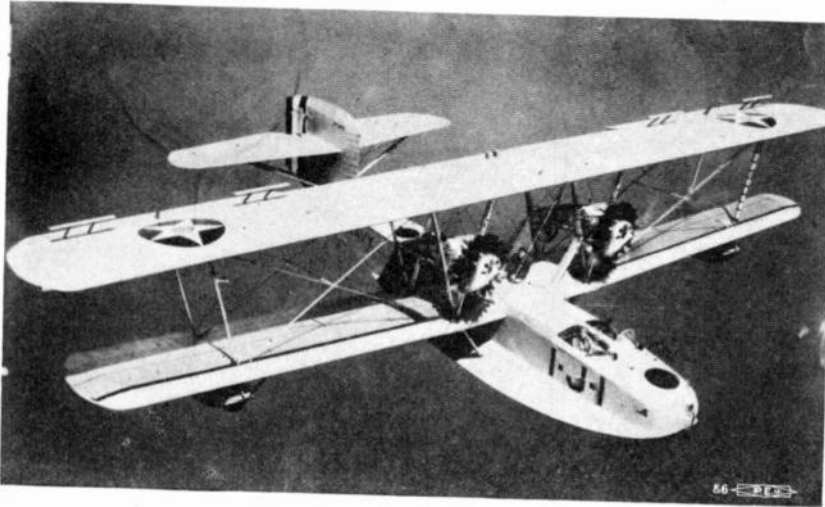

Aviation fans as well as others interested in our national defenses are giving attention to the latest patrol plane of the navy. The picture is of the giant flying boat of the PN type, designed to carry loads of great weight and magnitude, cruising over San Diego, Calif. The mechanism indicates power and dependability, if not speed, and is significant of the coming trend in aerial navigation.



According to George E. Faucher, its inventor, a pier constructed like the model shown above will furnish an entire city with its electricity. The first model was exhibited in Los Angeles. Built like a pier 1,000 feet long, the "V" of the machine points oceanward and as the waves roll in they are split and operate two series of turbines on each side. The turbines are of steel and encased in air- and water-tight tanks that float.



Artificial sunburn through the violet ray has been inaugurated for the first time at the Leona Farms, Cary, Ill., where John Hertz keeps his seventy-five thoroughbred racing horses. His \$2,000 exclusive horse beauty parlor supplies artificial sun in winter.



Col. Chas. A. Lindbergh piloted this giant amphibian 10-passenger Sikorsky from the States to the Canal Zone, officially inaugurating the Pan-American Airway's new service to that territory. The airliner has a speed of 110 miles an hour.

## How to Operate A. C. Receivers

(Continued from page 11)

The main trouble comes from cabinet vibration. If the grill panel in front of the speaker is loose (or any other part of the cabinet), it should be glued and screwed securely into place. The speaker should be pushed *tightly* against the front opening and screwed down solidly. The outer, round edge of the cone, however, should not be screwed to the front grill. This would place a strain on the cone and possibly throw it out of alignment.

If the roar still persists when the volume is turned up, the speaker compartment should be lined with acoustic-type BB Celotex, which will do a lot toward deadening the vibration. If necessary, felt-lined weights can be placed over the detector tubes to keep them from vibrating. These tube covers can be purchased in most radio stores as they are used in many factory built sets.

When the set has a bad a.c. hum, which diminishes when the units are operated out of the cabinet, it is a sure sign of electro-magnetic coupling. This occurs when the magnetic fields of the audio transformer cross the field of the power supply unit and the dynamic speaker. Shielding will usually remedy this trouble. Heavy sheet aluminum should be used and the entire shelf which holds the receiver should be covered. If the power units go above the receiver chassis then, of course, the shielding should be placed under the power units. This aluminum shield should be grounded after the proper location has been determined.

Receivers in class three hum because of many things. If the home built a.c. set has not been supplied with suitable by-pass condensers, then the operator is in for lots of hum. Regenerative circuits in an a.c. receiver are undesirable because the hum gets very pronounced as the oscillating point is reached. However, since this article cannot cover inherent defects in the designs of receivers, I will offer suggestions on the handling of accessories, with better operation in view.

A eliminators are a great source of trouble. They should *always* be used with a volt meter floating across their output terminals. The control should be set so that the meter reads 5.8 to 6 volts while the receiver is in operation. Most A eliminators hum and most of them can be improved.

B eliminators can produce a.c. hum, motor boating, and much distortion. One quick way to cure all three at once (in most cases) is to use a large by-pass condenser. A Mershon electrolytic condenser of the Q-9 type has four 9 mfd. sections which will stand up on any circuit not exceeding four hundred volts.

The copper can of the condenser is negative and it should connect to B negative on the B eliminator. The other four top connections can go to the B plus taps such as B+45, B+67½, B+135 and B+180. This addition will invariably produce much steadier operation and improved quality of tone.

Lastly, remember that your set may be entirely OK and that possibly you have mixed up the voltage controls on the power unit. There ought to be a law requiring every radio set owner to have a good high resistance volt meter. Why not get a two-scale meter? While you aren't measuring plate voltages with it, it can be tied on to your A unit, doing continuous duty.



## ENSCO SEMI-DYNAMIC

### A New Principle in Loudspeaker Design

A speaker that you can put together in a half-hour. No external power is needed—you merely connect it to any set. The power, range and quality will amaze you. Only 17 inches square by 7 inches deep. Also the famous Enesco Cone Kits for wall, console or pedestal and the piano unit that makes a loudspeaker of your piano.

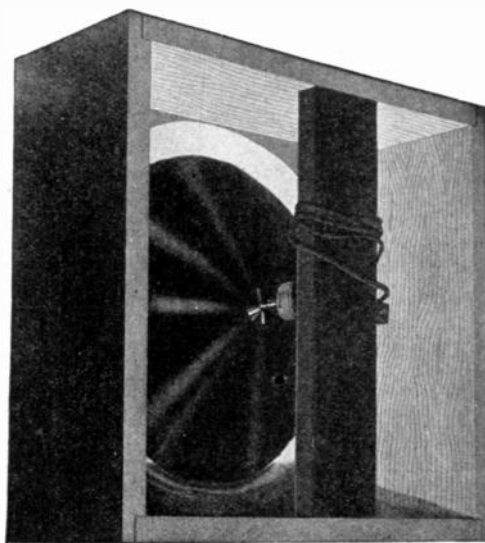

Rear view of semi-dynamic showing general construction

Use the free reply card on page 3 in this issue and send for full information.

**Enesco Products Company**

Main Office: 25 Church St., New York, N. Y.

## HOTEL MADISON NEW YORK

In the HEART of NEW YORK'S BUSINESS AND SHOPPING DISTRICT

10 Minutes to All Theatres

AN UP-TO-DATE HOTEL AT MODERATE PRICES

ALL LIGHT ROOMS WITH BATH

**\$2<sup>00</sup> to \$3<sup>50</sup>**  
Per Day

\$14.00 to \$17.00 Weekly

ROOMS WITH RUNNING WATER

\$1.50 to \$2.50 Use of Bath, \$9.00 to \$12.00 Weekly

### Better Yet

Dolly: "I'm in love with a voice."  
Polly: "A radio romance?"  
Dolly: "No, the voice that says, 'Where do you wanna eat tonight?'"

# On the Road to the Spirits' Abode

(Continued from page 16)

That evening he consults a card reader for advice about a business venture and on the way stops to see a numerology specialist about changing his name to one with a lucky number of letters. It costs him \$10, but his fortunes begin to improve from that moment. Hardly does he get to the street when he sees the new moon over his right shoulder, which is easily worth the price. The moon is so potent in the affairs of men that it is worthy of careful attention. Its signs ought not be misinterpreted by the careless and ignorant. It still makes work for the lunacy commissions, as we know to our terror when we wake in the night and find it shining in our faces. And over a large portion of the world's greatest farming country the moon still determines potato planting time.

The skeptical realism of the awful generation of today has strangely failed to free weddings from the ancient pre-sumptions. The girl who changes her name but not the letter knows she is taking chances. If on her way to the church she meets a load of hay it is a good sign. She wears "something old and something new, something borrowed and something blue," and never lets the captive bridegroom see her in the wedding dress before the Lohengrin business starts. She tosses her bouquet to the bridesmaids and watches to see which one catches it, for it is she who will be the next at the conjugal altar. After the wedding guests have showered rice and old shoes, they go home for a nightmare on wedding cake. And this is how modernistic a wedding is.

## STARS GUIDE PROMINENT MEN

Government officials, prominent politicians and financiers are known to guide their affairs by the stars. This may account for the way some things are done. A few years ago we read in a well-known magazine of the alleged influence of Madame Marcia, the astrologer, on the career of the late eminent Warren G. Harding. Tales of mystic seances in the executive mansion were seized upon by his foes to recently pitch out of his chair the chief executive of Oklahoma. Governor Johnson was disclosed as a student of Yogi philosophy and also attracted by Rosicrucian teachings. He had often explained that he signed bills at certain hours of certain days because of the favorable signs of the zodiac.

Weird beliefs, now as in early days, have much to do with shaping the course of business. The practice of the old Romans in divination by the pendulum is today seen in the selling of apparatus for \$2 to determine the sex of a chicken from the egg. Nobody wants the thirteenth seat in a parlor car and the thirteenth floor is eliminated from even the newest hotels. Although some realty corporations will break ground for a new sky-scraper on Friday, few of their cloud-piercing towers have thirteenth floors designated as such. Nobody wants to do business on the thirteenth floor, they tell us, and will not rent space. Everywhere one observes that the floral horseshoe goes right on bringing good luck to businesses, even to coffee shops and filling stations.

A young woman doing extension work in a rural community, where the purest Anglo-Saxon is dominant, was driven out on the ground that she was teaching witchcraft. She told fairy stories to the children. These, the authorities argued, were either false (in which case she was a liar) or they were true and hence were witchcraft.

The learned and good men who conduct our publications, it seems, are not free from certain notions that had high place during the Dark Ages. The now managing editor of one of Chicago's great dailies once tearfully remonstrated with a subordinate against the latter's habit of wearing an opal ring. The boss declared he would not wear one of those cussed things for a million dollars. A crow is the most deadly harbinger of evil, declares one hard-boiled, go-getting Chicago publisher. Other birds, animals and inanimate articles he regards as omens to steer clear of.

Pictures of none of these things are permitted in his organs of light and leading. The editor of the American Standard of August 1, 1925, attributed the death of William Jennings Bryan to spells wrought by his enemies and not to over-eating, as suggested by those who knew his habit of six meals a day.

The general atmosphere has become so foggy with superstition that no one is greatly surprised at the outbreak of witchcraft.

Not so long ago a lad gathering chestnuts on an Ohio woodland stumbled onto some first-hand information on evil spirits and how to get rid of them by silver bullets. He found three upstanding pillars of the community firing at a lock of hair on a tree. It developed that the hair was from the head of the wife of one of the men, the other two devil chasers being his brother and their father. They were sure that if they could drive the hair deep into the tree with silver balls the demons that had possession of the woman and were terrorizing other members of the family would be put out of business.

Although it was well understood in the community that the younger Mrs. McCue was bewitched, many were hardly prepared for the news that the men of the house had tried to burn the woman to death. While witch chasing was going on in that region more or less all the time, this was the first time such extreme measures had been taken. The young wife's story of how the three, failing to cure her by milder means, had carried her at night to a blazing log heap was corroborated by her burns. But being a devil for luck, she had fought from her captors to freedom. When the lady brought suits for divorce and for damages the matter became a celebrated case. The trials revealed that members of the household had resorted to fasting and prayer to relieve the afflicted woman. They forced her to diet on such magic viands as bats' ears, snakes' tails and toads' eyes.

The witch burners' main defense was that they acted for the stricken woman's good as well as for their own safety. They thought they were doing the will of God.

The recent outbreak in Pennsylvania when a youth killed an old man who embodied an evil spirit that was "hexing" seems to suggest that witchcraft is a rather well established institution and may go on forever. Like burnings, klan outrages and voodoo rites it shows an incurable belief in evil.

The Pennsylvania youngsters declared that they believed it was necessary to obtain from their victim a book called "The Long Lost Friend" or else cut from his head a lock of hair and bury it eight feet underground. He was killed, they say, because he resisted their efforts. On hearing his sentence to life imprisonment one of the defendants, Blymer, said: "Oh, well, I don't care. The hex that Rehmyer put on me has gone since his death, and I can eat and sleep now. Even in prison it will be better than it was before."

White women were numbered among the best paying clients of a Voodoo temple run by a colored "doctor" at Camden, N. J., until the police put the joint out of business. These fair customers paid handsomely to have the black magician cast spells on their enemies, mainly women who had stolen the love of their husbands.

Progress of Cupid struck a bump at Charlotte, N. C., when the authorities of that hard-hearted burg sent to jail Prof. J. H. Branderwine for selling magic love potions guaranteed to win the affections of those who drank thereof. Heartbroken husbands and wives who wanted to corral the straying affection of their life partners or achieve new ones were among the professor's ready buyers. One lady gave her husband an overdose and he died, while a minister who wanted to win back his wife almost killed her with a magic draught.

In all ages the spread of belief in the possibility of exercising a malign influence at a distance has been found favorable to an outbreak of witchcraft.

(Continued on page 68)

## Eliminates Radio Disturbances

RECEPTION in the average radio set is greatly improved by the use of an aerial buried in the earth. This has been proved conclusively in exhaustive tests recently completed, according to an announcement by Underground Aerial Products Inc., Chicago, makers of the new Subwave-Aerial. With this new underground aerial attached to the average set, much greater selectivity and distance is achieved and electrostatic interference is eliminated.

Tests were made by set owners as well as by radio experts. F. R. Steel, 622 Stratford Place, was one of the set owners making the tests. According to his report, he has been unable to get stations outside of Chicago during the year and a half he has owned his set. On January 28 he attached the Subwave-Aerial to his set, keeping the old overhead in place.

"During that evening," Mr. Steel says, "I brought in fourteen outside stations clearly and distinctly. I practically circled the country. The list includes CFRB, Toronto; WPG, Atlantic City; WBT, Charlotte, N. C.; WAPI, Birmingham; KFOA, Seattle; and many inside of that circle. Reception was just as clear as I ever had on the local stations.

"In making the test, I would switch to the old overhead aerial when I had a distant station on the Subwave, but could not bring it in at all. However, the increased selectivity I had with the Subwave was of much greater importance on my set than the distance.

"Each of the powerful Chicago stations spreads over eight to ten points on my dial with the overhead aerial. The result is that my entire dial from 9 to 90, was taken up by Chicago stations. With the Subwave attached, during the busiest broadcasting hours, I brought in KOA, Denver at 50½; WHAS, Louisville, at 51½; WCCO, Minneapolis, at 52; WBAP, Fort Worth, at 53½. And this with a set on which I have had to turn ten points on the dial to tune out a local."

The electrostatic capacity of the Subwave-Aerial was subjected to a most severe test. Two experts dropped the Subwave into a small hole in the earth just fifty feet from the 60,000-volt power line of the Chicago Sanitary District plant in the north part of Chicago. They used the batteries in their Ford car for radio power. They tested both a single dial Atwater Kent, Model 35, and a five-tube Freshman set. The test, made at 5:45 p. m. on January 27, brought in several stations, including St. Paul and Toronto, without the slightest interference from the 60-000-volt power transmission line.

Full information regarding the Subwave-Aerial can be procured by filling in and mailing one of the Business Reply Postal Cards on Page 3. No stamp is required—just sign the card and deposit it in a mail box.

## New Way to Refinish Autos

WE freeze our own ice, a thermostat tends the furnace and now another industry is about to be revolutionized by scientific progress. This time it's automobile refinishing.

After more than a year of research and tests, the Renuzit System, of Chicago, has announced the perfection of a new method for refinishing cars. According to the results of the tests, any car owner can apply Renuzit in about thirty minutes and get a perfect finish. No brush is used. It is applied with a cloth.

Renuzit is not a paint, cleaner, polish, varnish, wax or enamel. It is a clear liquid which restores the bright luster of the original finish of the car. It has proved to be harmless to any painted, varnished or enameled surface and does not collect dust.

Extensive production plans have been completed only after Renuzit had proved its value in the hands of more than one thousand car owners. These average drivers have proved that there is a demand for such a method and that Renuzit is doing it, the manufacturers claim for it.

Full particulars regarding Renuzit can be had merely by signing and mailing one of the Business Reply Postal Cards on page 3. No stamp is required. This is something new.

Use the Business Reply Postal Cards on page 3. They are for your convenience. No stamps required.



**Introduces**  
"The **PRINCE**"

### A New Loudspeaker

of an  
**Already Famous Line**

This the latest and most popular loud speaker in the well known Amplion line has the new cone assembly with Amplion balanced armature unit. The cabinet (handsome two-tone walnut with a fine piano finish) while small in size is very efficient and it functions as a soundboard producing a natural tone of unusual sweetness. In appearance and performance it equals any \$50 speaker on the market—yet its price is **\$23.50** only.

If your dealer cannot supply you send your order direct. Satisfaction guaranteed or money refunded. Catalog on Request.

**Amplion Corporation of America**  
133 West 21st Street New York



**If You PRIZE YOUR RADIO RECEIVER**

*Every Part Should Be The Best You Can Buy*

For accurate control of voltage in radio receivers or eliminators depend on "Electrad"—the name that stands for *Resistance Reliability*.

Prominent radio engineers and circuit designers the world over use and recommend Electrad Truvolts, Royalties, Phasatrols and Tonatrols. Let their experience be your guide in planning your radio receiver or "A" and "B" eliminators.

Write for Free Circuit Data and Information on Any Voltage Control Problem.

Dept. W.L.4  
175 Varlick Street, New York

**ELECTRAD** Inc.

# Radio Controls the Nation

(Continued from page 9)

their families almost a fifth of the entire population of the country, and representing not only its actual membership, but the many millions of men and women who toil, has asked the Federal Radio commission for *just one channel* of the eighty-nine available in this country, together with ample power and adequate time of operation. *The Federal Radio commission has denied this petition*, and has granted to Organized Labor's Station WCFL at Chicago, which has been built and supported during the past three years by voluntary contributions of labor unions and listeners, the right to broadcast on only 1500 watts power *during the day time only!* In view of the fact that workingmen and women do not return from their work until after six o'clock in the evening, it is manifest that the limitation put on Station WCFL by the Federal Radio commission practically destroys its usefulness.

## DENIES LABOR BUT FAVORS TRUST

In other words, the Federal Radio commission takes the position that Organized Labor, notwithstanding the vast number of people who constitute its membership, notwithstanding the unparalleled service it has rendered to workingmen and to the general public in the past fifty years, notwithstanding the fact that it has principles, policies and ideals of the utmost value to society which it wishes to promulgate, notwithstanding the fact that the working people of the country with their families constitute ninety percent of its population and the very bone and sinew of the nation, notwithstanding the fact that all other radio broadcasting stations of any importance, as well as the newspapers of the country are owned by Capital and are almost unanimous in their opposition to the ideals and principles of Organized Labor, notwithstanding the fact that Organized Labor is not seeking to make a profit from Station WCFL, but is seeking solely to render a public service, nevertheless, the Federal Radio commission, in its wisdom, has seen fit to deny this great institution *one single broadcasting channel* out of the 89 available, while pouring into the lap of the Radio Trust six or seven such channels with unlimited time of operation, besides numerous other broadcasting stations with part time operation.

## CHOICE CHANNELS GIVEN TO THE UNDESERVING

Metropolitan newspapers, which already have a powerful means of communication, but which are nevertheless local institutions, are handed the choicest wavelengths, with ample power and unlimited time of operation. Hundreds of private individuals and corporations who are seeking solely to make a private commercial profit out of this divine gift to mankind, are granted choice channels with ample power and time of operation. But the great body of millions of workingmen in the country, represented in the American Federation of Labor and its affiliated organizations, are told that it is not "in the public interest, necessity and convenience" for them to have a voice on the air!

This is the last Great Public Domain. A few squatters have set up their tents, turned a few furrows, and now ask the nation to confirm in them title to a continent! What do they care for the "public interest, necessity and convenience"? What they want is to make money, to acquire power and to control in their interest this unparalleled new means of communication.

Never in our history has there been such a bold and brazen attempt to seize control of the means of communication and to dominate public opinion as is now going on in the field of radio broadcasting. And never in our history has the federal government shown such a crass disregard and contempt for the rights of those who toil.

## THE BATTLE OF GIANTS

This is a Battle of the Giants. On the one hand stands Organized Capital seeking to grasp and monopolize for itself, for commercial profit and for propaganda in its own interest, this vast and immeasurably valuable means of communication. On the other hand stands Organized Labor, armed with right and justice, battling for some measure of freedom of speech and freedom of the air, and for the right to have *one out of the eighty-nine broadcasting channels* left open for the dissemina-

tion of the principles, policies and ideals for which Organized Labor stands. It seeks no profit; it wants no commercial gain, but it does want an opportunity to serve the workingmen of the country, and through them, the nation at large.

## WHAT IS PUBLIC NECESSITY?

What is the "public interest, necessity and convenience" which the law fixes as the sole test for granting radio licenses? Certainly it is the same as the "public welfare". That which contributes to the health, comfort and happiness of the people is in the public interest. That which provides wholesome entertainment, increases knowledge, arouses individual thinking, inspires noble impulses, strengthens human ties, breaks down hatreds, encourages respect for law, is in the public interest. That which aids employment, improves the standard of living and adds to the peace and contentment of mankind is in the public interest.

Is it in the "public interest, necessity and convenience" that this marvelous new means of communication should be placed within the control of a few great corporations? Or handed out as a free gift to a few hundred private business concerns for commercial exploitations? Or sucked into the maw of great metropolitan newspapers, already in uncontrolled possession of power that threatens the welfare of the country? Is the public interest, necessity and convenience to be determined by noisy acclaim? If so, then the movies overwhelm the universities, and are themselves outranked by a ball game or a prize fight. The cheapest sex novel would then put to shame the greatest scientific treatise.

Is it in the "public interest, necessity and convenience" that Bill Jones of Podunk have a radio station to advertise his garage? Or that a great public utility monopoly operate a 50,000-watt station to further its interests?

Is it a matter of public necessity that twenty radio stations in one city pound the air with the same jazz tunes?

The "public interest, necessity and convenience" is nationwide. It is age-long. It has to do with the physical, mental, moral, social and economic welfare of all of the people. It is not greatly concerned with Bill Jones' garage, or the private profit which a station owner hopes to derive from his broadcasting operations. It is not enhanced by the granting of special favors to a few individuals or corporations, however rich and powerful they may be.

The public interest, necessity and convenience requires that radio broadcasting provide not only entertainment, but information; not only music but science, history, economics, and all the other things that make for human welfare. It requires that the serious problems of life shall be presented,—not from one group or one viewpoint only, but from many groups and many points of view.

## MUST HELP SOLVE LIFE'S PROBLEMS

The great things of civilization are not sob songs nor symphony orchestras. They are matters that have to do with employment, with home life, with health, with the standard of living, with great economic and industrial problems that enter into the web and woof of the daily existence of all the people. To serve the public interest, radio must pour into the homes of the nation, not only entertainment, but something that will help solve the practical problems of every day life.

Is it in the "public interest, necessity and convenience" that all of the 89 channels for radio broadcasting be given to Capital and its friends, and not even one channel to the millions who toil? Will the public interest be served by opening all channels of communication to those who employ, and denying any channel of communication to the vast group of employed?

Organized labor has contributed immeasurable service to the nation. It has vastly improved working conditions, raised the standard of living, infused hope and courage and patriotism into millions of hearts. It has battled for needed reforms, sane and useful legislation, and social and economic justice for all who toil. It has established principles, policies and ideals which are as essential to the welfare of our country as is sunlight to the growing fields. It has a

(Continued on page 69)



## Makes Radio Good in Summer

HOW many serious radio fans fear that the coming of spring and summer will interfere with radio reception? There was a time when the fan prepared to store his receiver in an out of the way corner at the robin's first notes. This is no longer necessary. The utmost value of the investment in a radio receiver can now be derived.

Static and electrical disturbances throughout the warm spring and summer months will naturally discourage the ardent fan and failure to tune his favorite distant stations will cause him to seek some means to compensate for the effect that warm weather has on radio reception.

Successful short-wave reception is now a reality. An additional receiver need not be purchased. A recent development of the George W. Walker Manufacturing company, 13301 Durkee Avenue, Cleveland, Ohio, makes possible the reducing of static and electrical interference and at the same time builds up the volume and sensitiveness of the receiver to a greater degree than what it possesses even during the winter months. Selectivity is greatly improved. This new development is known as the Multi-Unit. The word "multi" is used to indicate the many uses that this small and attractive unit may be put to.

Furnished with each Multi-Unit are two plug-in coils wound with silk-covered wire on bakelite forms. Included also is an adapter plug which, when fastened to the unit and plugged into a socket of the receiver, makes instantaneous connections to the filament and plate circuits of the receiver.

One of the plug-in coils furnished covers a wave band of 200 to 550 meters. The other coil covers a band of about 15 to 95 meters and permits short-wave reception of stations merely by plugging the unit adapter prong into the detector socket of the receiver. No change in the wiring is necessary.

The use of this Multi-Unit as an extra stage of tuned radio frequency is similar, and yet more efficient, than to have another tube and extension of circuit built into the receiver.

Here at Station WCFL one of these Multi-Units is being used. Stations never heard before are tuned in with ease. The selectivity of the receiver with the Walker Multi-Unit attached is such as to keep Station KYW concentrated to but a few graduations of the receiver dial, where formerly they were heard at any setting and prevented the tuning in of other stations.

There are many other uses for the unit. For example, the unit will function as a screened-grid pre-amplifier, r. f. booster or extra stage of tuned r. f. ahead of either an a. c. or d. c. receiver, short wave receiver, audio oscillator, regular broadcast receiver, or portable set, remote control converter, single dial converter, experimental unit, wave trap, or wave meter.

The advanced radio fan or service man will find the Walker Multi-Unit indispensable for checking the wave length and calibration of receivers. To determine the resonance of circuits, testing of tubes for oscillation and regeneration, neutralizing receivers, balancing condensers, laboratory measurements, transmission, generating a heat frequency for super-hetrodyne, growler for measuring efficiency of shielding material, etc.

As a portable receiver for camp or excursions, all that is required in addition to this Walker Multi-Unit are two dry cell batteries, tube, short antenna and ground wire, and a head set or loud speaker, depending upon the distance from a broadcast station.

Summer should hold no fears for the radio fan. Let's make use of our receivers all the year around.

Addresses of dealers who handle the Walker Multi-Unit may be procured merely by filing in one of the Business Reply Postal Cards printed on page 3. No postage is required.

Use the Business Reply Postal Cards on page 3. They are for your convenience. No stamps required.

## Radio Engineers Test ... they don't guess

THAT'S why you'll notice Polymet Parts specified so often in construction articles. Experienced engineers have learned of the quality and dependability of Polymet electric set essentials and incorporate them wherever possible.

For instance, H. G. Cisin, well-known radio engineer, describes "The Screen Grid Find—All Four" on page 44 of this magazine.

For the maximum efficiency of your set, Mr. Cisin recommends that his specifications be followed exactly. That you use standard Polymet Parts, wherever called for, is particularly important. If your local dealer hasn't them, order from The Barawik Company of Chicago.

Write for our catalogue and construction diagrams of other sets incorporating Polymet Products.

Polymet Manufacturing Corp.  
601-A Broadway, New York City

**POLYMET**  **PRODUCTS**

## CHI-RAD

*would like to make some  
more friends among  
Federation members*

QUALITY SETS, KITS,  
AND PARTS AT PRICES  
THAT COMPETE

**Chicago Radio Apparatus Co.**

415 So. Dearborn St.

Phones Har. 2276-7

CHICAGO

# Labor Seeks Only Equality in Radio

(Continued from page 21)

Up to the present time, it seems to have been assumed that if a station furnished entertainment popular with many people, it was ipso facto, operating "in the public interest, necessity and convenience," and that the station with the greatest number of listeners was the "best" station. Acknowledging that there is much to justify those who hold to this view, and with a full appreciation of the important element of *entertainment* in a radio program, we submit that popularity is an inadequate test for "public interest, necessity and convenience." The most popular of entertainments is a prize fight. Next to that, a ball game. The most popular books are usually sex novels. We offer no criticism of these things, but we do not regard them as standing first in the test of public interest, necessity and convenience. We believe that radio is too great, too close to the daily lives of all of the people, to be devoted almost entirely to popular entertainment.

## SHOULD COVER MANY FIELDS

Some stations may well be devoted entirely to these programs. Probably all stations should furnish some of it. But we think the public interest requires that radio cover many fields of human interest; that some stations may well be devoted to subjects that do not interest the multitude, and yet be rendering a greater public service than some others that entertain a great audience. The public interest may be more truly served if 10,000 people listen to a scientific lecture, than if 1,000,000 weep over "Old Pal."

To further illustrate: Suppose there were only 89 printing presses available in the United States for all kinds of printing, and these were under government control, licensed to users. Would these presses be licensed solely, or chiefly, for printing "best seller" novels? Would *any degree* of "popular demand" for sporting news and murder stories prove that such publications were in the "public interest, convenience and necessity," to the exclusion of books of science, history, biography and economics?

Certainly a wise licensing authority would make a broad study of the needs of all the people; it would allocate a reasonable service to entertainment, to news of the day, to books of all kinds; it would give opportunity for expression to every reputable and substantial class or group. It would not let any single user monopolize even one of these precious printing presses, even though he promised to print what he considered a "diversified" output. Such a licensing authority would not say to the millions of organized working men and women of the country: "You cannot use any of these printing presses to promulgate your principles, ideals and policies; they are all needed to supply the public demand for books of entertainment and metropolitan newspapers." Those printing presses would be treasured as the sacred heritage of all the people.

We think of the 89 radio broadcasting channels in the same way. We believe the Federal Radio commission has yet to perform its greatest service in a true interpretation and application of the "public interest, necessity and convenience," in the administration of the Radio law. It is our hope that this will be done within the coming year, and that there will be substantial changes in the allocation of broadcasting facilities.

## OTHER PROBLEMS FOR COMMISSION

6. The Federal Radio commission has before it most serious problems relative to radio facilities outside of the broadcasting band. While less obvious to the laymen, and almost unknown to the people generally, these so-called long and short wave channels are becoming daily more significant, and may quite possibly overshadow the broadcasting band in their commercial value. This is a field requiring great study and statesmanship, if the public interest is to be adequately protected.

It would be unfortunate if these great functions of the Federal Radio commission, now in process, should be hindered or delayed. They should be in the exclusive care of the ablest men available, with ample funds and adequate authority.

7. A further reason for continuing the commission another

year is to keep the whole radio situation *fluid* under the control of Congress.

The art is new. It is developing rapidly. It is different from anything else in human experience. It is rigidly limited as to the number who may engage in it.

## RADIO DEMANDS FURTHER STUDY

We believe it to be of the very first importance that there be more time for development, for study of the art and its problems, and for a better evaluation of all the elements involved, before any permanent administration is established or any final policy adopted.

Another reputable witness appearing on behalf of the National Association of Broadcasters, has urged an early stabilization of administration. The National Association of Broadcasters may be designated as "The Happy Family." They have got what they wanted. They have no serious complaint. Now they want stabilization of administration, and longer license periods. Why do they want this? The reason they give is for the purpose of protecting "capital investments" and "future commitments." We emphatically disagree. We see in this suggestion the advance guard of an army to protect "vested interests" in radio. The very suggestion is a warning. For our own station, we claim no "vested rights" to continue broadcasting. We built our station with full knowledge of the law, and of the possibility that an order of the Federal Radio commission may render our investment worthless. That is a chance we and all other broadcasters took and shall take in future. The thing we most fear is that the claim of "vested rights," subtly suggested, and persistently urged, may result in "freezing" the broadcasting setup, so that, notwithstanding the letter of the law, the result will be virtually to turn over to a few great corporations this immeasurably valuable public franchise, in perpetuity.

## OPPOSED TO "PROPERTY RIGHTS"

Some broadcasters are now urging in court that any restriction of their broadcasting operations is an invasion of their "property rights." In effect, they deny the power of Congress to regulate this new form of interstate commerce, at least without compensating them for alleged damages. We affirm that a broadcaster has no more property right to the use of a cleared channel, even if he was the first to use it, than had the man who first floated a raft on the Mississippi river to claim that river as his private highway.

General Electric company, with a high-powered, exclusive channel station at Oakland, and another at Denver, is now in court demanding that its "property right" to operate a *third* station in New York with 150,000 watts power, on a *third* cleared exclusive channel, be protected!

It is clearly evident that, even if the *legal* right be denied, there will be an almost irresistible demand, on alleged equitable, moral, political and other grounds, that stations now on the air with high power and cleared channels, be permitted to continue, and the theoretical short time license will gradually metamorphose into a perpetual franchise.

## QUESTION SHOULD REMAIN OPEN

We regard it of the utmost importance that the whole matter be kept fluid until Congress has had time adequately to study the subject, and to enact suitable legislation. The whole matter is of such great and growing importance, the development of radio so rapid, and its possibilities so bewildering, that we believe there should be a broad and extended study of the subject by Congress, before the administration of the law, or the law itself, is permanently stabilized.

8. We believe the commission has most seriously misinterpreted the public interest clause of the statute in establishing forty cleared channels and permitting the use of so much high power. We have applied for a permit to build a 50,000-watt station and for the use of a cleared channel. If such high power is to be used by others, we want the same privilege, otherwise we shall be smothered. (Continued on page 69)

## The Screen-Grid Find-All Four

(Continued from page 44)

Seal GSX 201-A tubes and a GSX 171-A power tube. The remarkable results with the original Screen-Grid Find-All Four were obtained using these Gold Seal tubes. A hard rubber panel is used, having the new and attractive sunburst finish. The sub-panel may be of Ace or Radion hard rubber. Corwico braidite is the hook-up wire used.

The Screen-Grid Find-All Four works perfectly in connection with a properly designed B and C eliminator. An A eliminator may also be used, if this is available. The B and C eliminator built for the Screen-Grid Find-All Four uses a Thordarson R-280 power compact. Polymet filter condensers are called for. In order that B and C voltages may be varied conveniently, an Electrad Truvolt divider is used. A Gold Seal GSX 280 tube provides full wave rectification. A Yaxley full automatic power control adds greatly to the utility of the complete outfit, especially where a storage battery is used with a trickle charger for the A supply.

After a number of comparative tests, the Amplion Prince model cone speaker was selected for use with the Screen-Grid Find-All Four. This speaker, while constructed on the magnetic principle, is essentially dynamic in action and closely resembles the dynamic speakers in tone quality and appearance. While it is able to bring in the deep bass notes with the same degree of fidelity as the dynamic speaker, it possesses a number of important advantages over all dynamic speakers. First of all, it is more sensitive to weak signals and hence is more desirable in connection with a receiver designed to bring in distance. Second, it can be operated more efficiently and with better results on low volume. Last, but not least, it costs less than half the amount required to purchase a dynamic speaker. The direct drive unit used in the Amplion speaker has an intense magnetic field, laminated pole pieces, light moving parts and noiseless transfer levers. A 9-inch burtex cone is used. The entire unit is enclosed in a well-designed two-tone hardwood cabinet which also functions as a sounding board and resonating chamber.

In testing the Screen-Grid Find-All Four it was found possible to bring in local stations using as an aerial a wire 12 feet long, thrown on the floor. In a great many cases the use of a ground wire was found to be unnecessary. It was possible to bring in a number of distant stations using an indoor aerial about 75 feet in length. In order to reach out and bring in stations from coast to coast, an outdoor aerial 100 feet long was used, with a 50-foot lead-in. In operation, the receiver was noted to be absolutely stable. No hand capacity and no microphonic noises were present.

Detailed instructions for assembling and wiring the Screen-Grid Find-All Four, also for building a B and C eliminator for it, will be sent upon request to any reader of WCFL Radio Magazine. To send in your request, it is not necessary to address an envelope and procure a stamp—just turn to page 3 and use the handy Business Reply Postal Card provided there for your convenience.

### Polymet Expanding Rapidly

TO KEEP pace with business which is setting new monthly sales records almost every thirty days, the Polymet Manufacturing corporation is again forced to install additional machinery and to enlarge factory space.

A large contract from Stewart-Warner has just been awarded to Polymet. This and other large orders have necessitated this increased capacity.

It would seem from this that 1929's radio season had started with a bang and earlier in the year than usual.

### A New Service for Our Readers

On page 3 of this issue are printed three Business Reply Postal Cards. These are for your convenience in answering advertisements or writing to WCFL Radio Magazine for information. No postage is required.

## 3 Y A — K G U

### New Zealand and Honolulu on the broadcast band

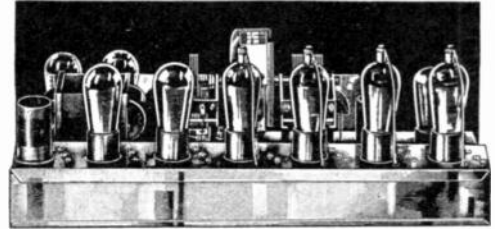

#### THE H. F. L. SPECIAL NINE with the new 250 power amplifier

Now you can get through. To Mexico, Alaska, Cuba and Hawaii. They crash in on a Special Nine. One dial tuning. One spot, 4 stage screen grid amplifier. 250 power amplifier. Steel chassis. 1930 models. Astonishing operation—sensational prices—A.C. set \$61.74. D.C. model \$55.86. 250 power amplifier \$45.28. Send for all information. Set builders write on business letterhead for special offer.

SEND THIS COUPON  
HIGH FREQUENCY LABORATORIES  
Office 12-28 N. Sheldon St., Chicago, Ill.  
(Gentlemen: Without obligation please rush literature on your new 1930 products.)

Name.....  
Address.....  
City..... State.....  
(Please print plainly)

# HFL

AN ARISTOCRAT OF NEW YORK HOTELDOM

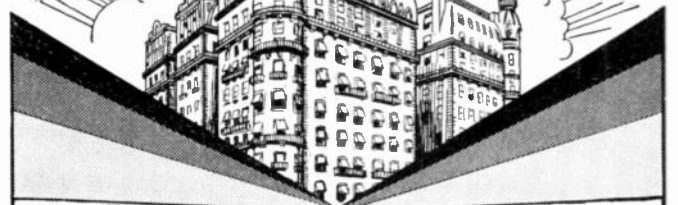

THE  
**ANSONIA**  
BROADWAY AT 73 ST. NEW YORK  
PATRONS OF PROMINENCE CHOOSE  
THE ANSONIA!

1400 Large Homelike Rooms

Comfortable Furnishings

Soundproof Walls

Rates Will Surely Please

Room with private bath from \$3 per day

For two..... from \$5 per day

Parlor, Bedroom and bath from \$6 per day

BOOKLET ON REQUEST

Wire at our expense for Reservations

# In Charge of WCFL's Programs

Here is Harold O'Halloran, Announcer, puts punch in his work. Known to Juniors as "Daddy Hal."



Franklin C. E. Lundquist, business manager of the Station, a constructive radio program builder. Founder and organizer of the Junior Federation.

Below is Musical Director Burt Squire, a necessary part of every entertainment. He is "Brother Burt."



## Greater Selectivity for Old Set

**M**ANY complaints are heard these days from owners of old sets with regard to selectivity. Whereas these same sets may have been amply selective a year or two back, they now fail to separate the closely packed broadcast channels.

It is obvious that selectivity is a matter of circuit design. The present-day set is selective because it has low resistance circuits, because it has shielding between the adjacent tuning components, and because it has tuning condensers with the proper capacity variation. The old-time set, without these fundamentals, cannot tune as sharply as the present-day set. Nevertheless, there are ways and means of improving the selectivity of the old set without changes.

The first consideration in improving the selectivity of the old set is to reduce the signal pick-up, especially when trying to tune out powerful signals. For this purpose, a suitable variable high resistance should be shunted across the antenna and ground connections of the receiving set. A table type clarostat is ideal for this purpose, since it calls for no alterations in the set wiring.

Making the detector less sensitive is another way of improving selectivity. This is accomplished either by substituting a suitable variable grid leak for the usual fixed grid leak, or placing a variable high resistance across the grid and grid return terminals of the detector socket. A grid leak clarostat, with a range of 1-10th to 10 megohms, is suitable for either application.

Shielding will materially help the old set. This may be done by lining the cabinet with tinfoil shellacked in place for the general shielding, and aluminum or other metal partitions between the tuning components.

## CeCo Again Pioneer

**E**ARLY in April, 1928, the CeCo Manufacturing Company of Providence, R. I., announced to the trade the release of an alternating current operated screen-grid tube. This tube employed the separate heater principle and required 1.75 amperes at 2.5 volts for its operation. At that time CeCo also used the fine wire mesh for the outer screen construction.

This particular type of screen grid tube turned out to be a very efficient tube and is now accepted as the outstanding

amplifier of today. Its use will undoubtedly become general next season as it has passed the laboratory stage of development and is now available to the public.

Many advantages result from the use of CeCo a.c. screen-grid tubes. For example, remarkable amplification is possible with a smaller number of tubes than is possible with the three element type. No outside antenna is necessary with equipment using a.c. screen-grid tubes, and in fact a piece of wire a few feet long within the room is sufficient. Due to a combination of conditions, less static and line noise results from sets using a.c. screen-grid tubes.

CeCo has pioneered the development of the a.c. screen-grid tube and its extensive use is merely a matter of time.

## Concerning Loud-Speakers

**U**NDER the title of "Loud Speakers," by Joseph Morgan of the engineering staff of the International Resistance Company, there has just been issued an interesting pamphlet. Mr. Morgan begins with a short explanation of the nature of speech and music, and then proceeds to outline the functions of the ideal loud speaker, its theoretical requirements, and the principles of its design. The remainder of the text is devoted to an illuminating consideration of the various types of reproducers available at the present time. Five classifications are listed, particular emphasis being laid upon the horn, cone and dynamic types. Each of these types is described as to its construction, the theory of its operation, its efficiency, and its advantages or disadvantages. In addition, the copy bristles with any number of invaluable hints which should enable the reader to get the best out of the particular type he happens to be using.

The pamphlet, known as Engineering Bulletin No. 5, may be had by addressing the International Resistance Company, 2006 Chestnut street, Philadelphia, Pa. For your convenience in sending for this pamphlet a Business Reply Postal card is provided on Page 3 of this magazine. Just write in the name of the pamphlet, sign your name and mail the card. No postage is required. This is a brand new service to magazine readers—try it.

You can answer any advertisement in this issue of WCFL Radio Magazine merely by filling in the Business Reply Postal Card on page 3. No stamp is required.

# Radio Tube Insurance Worth Having

THERE are many voltage controllers on the market now but the original, known as Resistovolt, still claims leadership. The new Resistovolt differs in appearance somewhat from the old one in that it has perforations on the outer surface which are a part of the air-cooling mechanism. It is also more compact taking up less room and its appearance has been greatly improved. It is manufactured by Insuline Corporation of America who have been manufacturing standard products since 1921.

The Resistovolt is a vigilant sentry at the danger point of your set. For less than the cost of one tube you banish forever the danger of blowing or gradually paralyzing your radio tubes. It automatically checks all line current voltage in excess of 110 volts, at which all tubes are built to operate. Excess line voltage, line surges, short circuits, line noises—terrors of a former day—may now be disregarded.

Resistovolt just plugs into the wall socket and its other end is a socket to receive the set plug.

It protects the tubes and set wiring of electric sets operating from house current and sets using any type of eliminator. It works either on direct or alternating current.

The surplus voltage which the Resistovolt checks, tends to heat up the special resistor, but by unique internal construction and a perforated outer casting this resistor is air cooled.

In case of a short circuit in the radio set this inexpensive device does the blowing out, acting like a fuse, the whole set of expensive tubes and set wiring remaining unharmed. At the same time it also acts as a lightning arrester.

Similar in appearance but taking more of a responsibility upon itself is the Antennavolt. It is of the same construction as the Resistovolt except for a special feature which provides the use of the wall socket for antenna purposes.

The antenna wire from the set is connected to the external knurled knob provided on the outer surface of the casting.

The Antennavolt gives all the tremendous advantages of a socket antenna, less static, sharper tuning, and purer tone reproduction, without tying up the socket for set current supply, plus giving Resistovolt automatic voltage control protection.

It is simple to install. Plug the Antennavolt into the wall socket outlet then connect the wire coming from the antenna binding post of the set to the external knurled knob of the Antennavolt. Insert set current plug to it and your set is ready to tune in.

Neither the Resistovolt nor the Antennavolt consume any current.

## Dresner Shielded Short Wave Converter

Wave Length  
Range 15 to 550  
Meters

SIMPLE TO ATTACH  
EASY TO OPERATE



Remarkably  
Low Priced  
16.50

Complete  
With 5 Coils

This new 1929 model, Dresner Shielded Short Wave Converter, is a useful accessory to any receiver. It requires no extra tubes or batteries and can work on any set. Enables you to get the best entertainment of the air being broadcast on short waves by many European and American Stations. Take advantage of very low price. If your dealer cannot supply you SEND Money Order DIRECT. (Specify whether to be used on AC or DC set.)

Dresner Radio Mfg. Co. 640 Southern Boulevard,  
Dept. W.—New York, N.Y.

Lowest  
Wholesale  
Prices

164  
PAGES  
of RADIO  
VALUES

A NEW CATALOG  
JUST OFF THE PRESS



YOU MEN  
Who Buy RADIO!

By making your problems our problems, we know the service you require—and to render you such service the entire Allied organization is dedicated—to give you the service you have a right to expect. Tremendous stocks, remarkable values and a real desire to serve, all combine to make Allied your ideal source of supply.

## Pre-Inventory Clearance Sale

OUR tremendous stocks must be reduced. Prices have been cut to the bone. Everything in our large stocks of radio merchandise is included. A new large catalog featuring these remarkable values is now ready. Every radio enthusiast—every dealer—every set builder should send for this new catalog—quoting lowest wholesale prices on everything in radio.

### SET BUILDERS!

Set Builders, Amateurs and so called "Hams" will delight in the unusual variety—and remarkable values that are offered in standard kits and parts. Tremendous stocks—real organization—prompt shipping service all combine to make Allied your ideal source of supply.

### RADIO DEALERS!

The live radio dealer who keeps pace with the rapid advance of radio will find much of real interest in the Allied Catalog. New A-C Sets, D-C Sets, Dynamic and Magnetic Speakers, television equipment, everything that an impatient radio public is demanding.

### LOWEST WHOLESALE PRICES

Allied Service will prove a revelation to you in what radio service can really be. Allied Executives, backed by years of training in radio, are practical men. Their vast experience has built up around them an organization trained to serve. Months of effort have built up a tremendous reserve that makes for prompt shipments. This stock is new, comprising the season's pick of such prominent manufacturers

as Silver-Marshall, Tyrman, Aero, Hammarlund-Roberts, etc. Buying right is half the battle. From the small set builder to the large dealer, your success depends upon gauging the public pulse of radio. Everything that is new in radio—the items the radio public is now demanding are here, ready for your call. Write now—the catalog is free for the asking.

Write for Catalog Now

**Allied Radio**  
CORPORATION

711 W. LAKE STREET, Dept. R, CHICAGO, ILL.

Postage Free—You can answer any advertisement in this magazine without buying a postage stamp.—See page 3.

# HELP WANTED

(Continued from page 33)

immediately began to imitate them. And from that day forward it has spread; yea, unto the Sun Kissed Shores of Sunny California (in fact, *especially* unto the Sun Kissed Shores of Sunny California) and the Rock Ribbed Coast of Maine.

Pick up the classified advertising section of almost any large daily in any large city of the United States, and you will find that the greater portion of the ads in the Help Wanted section are these phonies, predicated upon the scientific certainty that out of so many men hired, so many will sell a lot each to relatives or friends. Those who sell nothing cost the firm nothing, for they are on a straight commission basis, which means that they draw not a penny until they make at least ten for the firm.

There is, of course, nothing particularly wrong about the plan. In fact, it is more ethical than any one of a dozen other thoroughly accepted American business schemes. Every now and then, indeed, one of the suckers roped into taking a straight commission job discovers a real talent for salesmanship and makes enough money to buy an assembly room of his own, in which to ramp and roar to suckers he has roped in through phony classified ads of his own.

If there is any sadness incident to the plan, it is inherent in the fact that for every sucker who eventually goes across as a salesman ten or fifteen thousand fail and find themselves in bad holes, after having quit their thirty-five or forty-dollar-a-week steady jobs in order to become high pressure, psychological real estate.

These ten or fifteen thousand began to talk in all quarters of the city where Smug & Sleek operate. Hence their employment of clever copy-writers to write ads so thoroughly brilliant that suckers may still be brought in and run through the mill, to the annoyance of their relatives and friends. Also, it has become necessary to find new grinding teeth for the mill.

### III

One of these new grinding units is the characterologist.

Until a few years ago, characterologists were properly put in the same parenthesis with phrenologists, chiropractors, fortune-tellers and other such charlatans. But today, if there is a characterologist in town who hasn't a glass-topped desk, a gold cuspidor and a voluptuous stenographer, it is because he has a tinge of conscience, which is, of course, unlikely. Some of the contemporary real estate ads read like this:

At what trade or occupation or profession will you best be able to express yourself? Come in for a consultation free. Professor Psittacus, a world-famed characterologist, the very man who advised Al Smith to take up politics, will tell you at what work you will best prosper. He will not charge you one penny for the advice.

At first, these characterologists used to work for the real estate firms directly and obviously. They would have an office right in the firm's suite, and all applicants for positions would be sent to them. Unless the victim was deaf, dumb, blind, spavined, minus all four principal members and 75 per cent dead, he was told that the sun, moon, stars, his palm, the bumps upon his head, and even God Himself all advised his immediate entry into the real estate profession.

After a time a few of the thousands of applicants dredged up by the phony ads began to suspect that there might possibly be some connection between the characterologists and the firms in whose quarters they maintained offices. To relieve this suspicion, the characterologists were moved to other offices in the same building. Some of them even set themselves up in independent offices and examined applicants on their own hooks, after inserting their own phony ads. They would then apportion the applicants to different real estate subdividers, taking an overriding commission on anything the suckers sold to their harried friends and relatives during the short period in which they remained high pressure salesmen.

One characterologist of whom I wot even employed a man to circulate around his waiting room and whisper:

"Gee! This guy must be on the level: he advised me *not* to go into the real estate business!"

Another grinder is Free Classes in Psychology and Salesmanship. Thus:

Are you an untrained man? We need salesmen badly. Trained men. We can never get enough trained men to fill the vacancies we have in our organization. To meet this need we will train a few exceptionally bright young men free. We will give you, without one penny's cost to you, a course in Psychology and Salesmanship, which would cost you plenty of money at Harvard or Yale. See Mr. Tinker at once, Room 806, Foray Building.

At the present writing, alas, both the characterology game and the psychology and salesmanship game are petering out. The newest wrinkle is a course in Real Estating, Plain and Fancy:

Do you know any *one* profession thoroughly? How would you like to become an expert real estate practitioner? We will give you a complete training in every phase of the real estate business without one penny's cost to you.

The amazing growth of our firm has made necessary the employment of a huge staff. We cannot find sufficient trained men to fill the vacancies we have. Because of this we have decided to train men for these positions, at our own expense. Look around you. Do you know a single man who understands the real estate business thoroughly, who isn't making excellent money? Come in and sign up for your course, free of charge. Act now!

In many of the ads currently run, stress is laid upon the theory that "leads" will be given every man employed. Leads, in the real estate man's patois, mean the names and addresses of persons who want to buy lots. Theoretically, all the employed men have to do is to take these leads, go to the addresses indicated, get the victims' names upon the dotted line, and return to the office for a handsome commission.

In the ad that lures the ambitious realtor to the office, and in the bright little talks he hears in the assembly room, the word leads occurs as often as does the word Service in Elder Hays' communiques about the movies. But after the applicant has been officially made an employé he hears about leads again only if he insists upon being given them, with the threat of quitting instantly if they are not forthcoming.

There are a great many sources for these leads. The simplest is the telephone book, the most complicated is the prize contest.

At all the larger amusement parks in town, and at several other junctures where multitudes of morons are wont to disport themselves, Smug & Sleek and the other real estate firms who copy them, conduct contests for which the prizes are subdivision lots. These contests are carried on somewhat as follows:

Near the gate in Moonlight Park, is a neat little booth. Over it is a large sign: "Win A Lot Free!" At the counter and circulating before it are some damsels of persuasive tournure who ask visitors to sign cards with their names and addresses. These cards, they are told, will be deposited in a box, from which one card will be drawn by a virgin who is the seventh daughter of a seventh son. The person whose name is upon the card drawn will receive a lot free.

Whoever signs one of these cards is greeted at his doors several days later by a suave young man—usually one of the real salesmen attached to the firm, but sometimes one of the neophytes who are supposed to sell their aunts—with the information that he has won a lot.

"Just pay for the surveying charge, and this, and that, and the other, and the lot is yours free. An advertising feature, sir; the lot won't cost you one penny."

But the lot does always cost precisely what it is worth, plus a substantial profit for the firm. And that isn't the worst of it. Every sucker who falls for the scheme finds to his horror that he has bought a lot so narrow that even a garage couldn't be erected upon it. In short, he has bought precisely half of a narrow lot; the other half can be had on the installment plan. . . . When a kick is made that the lot is so narrow as to be no lot at all, the firm need point only to Webster's definition of a lot: "A distinct portion of land."

One may ask: "But do not all (Continued to page 71)

## The Semi-Dynamic Loudspeaker

By F. W. FARNHAM, Ensco Products Co.

THE history of radio reproduction, which is to say the history of the loudspeaker industry, shows more or less radical changes in design at intervals of approximately two years. We have but three distinct speaker types—horn, cone and dynamic.

Now each of these types has certain features to recommend it. The horn speaker under proper conditions develops a sharpness of definition or enunciation which is not often found in other types.

Taking up the question of cone speakers, if the cone is less than two feet in diameter it will be but little better than an air-column speaker. If a three-foot single, open cone of Alhambra or other very similar material is driven

by a unit having direct-drive feature, it will reproduce a greater natural range of tone values than all other types combined.

Next on our list is the latest loudspeaker—the "dynamic." Here we find a speaker that has apparently unlimited range. However, this type is not practical for any but a very powerful set. A good dynamic requires upward of 350 volts and a DC or AC lighting system.

A prominent engineer recently decided that it might be possible to combine the better features of the horn, cone and dynamic and produce a speaker for all around use. The Semi-dynamic reproducer was the result. The merits of this new type will be readily apparent. First, it employs a cone about twelve inches in diameter, the cone material being acoustically "dead." No ordinary cone paper will serve the purpose because they all have too much tendency to turn out tones of their own. This cone is secured at the outer edge by a ring of chamois or outing flannel of very soft texture. The baffle piece is then glued to a fourteen-inch hole in a baffle board of ply-wood. This is shown in the illustration Fig. 1. The drive unit is mounted securely to a back strip and connected by a short, heavy drive shaft. The unit is shown roughly in Fig. 1. This drive unit is of a special direct drive type using a straight armature and an auxiliary armature. It allows perfect damping of the armature. That is to say, the armature returns quickly to rest after each impulse without loss of motion. This feature is of the utmost importance if the full value of this arrangement is to be gained. A small brass apex is employed.

In operation, the impulse is transmitted to the cone and the entire surface of the cone and baffle board vibrate. The box allows just sufficient resonance effect to subdue any harshness and yet not enough to muffle the tones. As the armature is entirely damped in action, the bass notes do not distort. The brass apex gives a certain amount of rigidity at the point of contact of the drive pin and cone. This permits reproduction of the speech and higher frequencies with a pronounced clarity that is not usual in loudspeakers that cover a wide range. In addition to remarkable range and definition, the speaker possesses a mellowness and tonal roundness that persists at all volumes.

Here is a speaker that gives natural reproduction at any volume. It cannot blast or distort due to its radical design; it can be attached to any good radio set without special power or voltage; it is small in size, only 17 inches over all, and it can be made into a most attractive addition to your radio room. With a curtain or screen of gold cloth over the front, it looks like anything but a loudspeaker.

Not at all, Maudie, auto intoxication is not a hootlegger's car.—*Royal Arcanum Bulletin.*

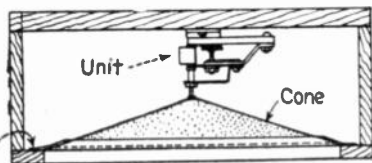

Chamois glued to baffle board  
~ SECTIONAL TOP VIEW ~

## REAL One-Dial Control

The sections of Hammarlund "Battleship" Multiple Condensers are matched to within 1/4 of one percent. Absolute precision is obtained by attaching a Hammarlund Equalizing Condensers to each section. Reverses in the frame provide for this.

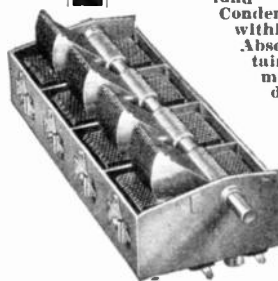

Write for FOLDERS

That means REAL One-Dial Control, with every circuit accurately tuned. Made in 350 mmfd. and 500 mmfd. sizes in two, three and four gangs. Your dealer sells them.

HAMMARLUND MFG. CO.,  
424-438 W. 33rd St., New York.

For Better Radio  
**Hammarlund**  
PRODUCTS

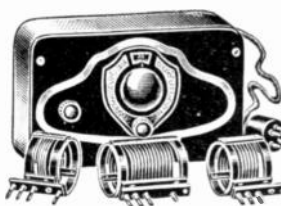

## 1929 "Aero-Call" Short-Wave Converter

Factory-Built. Ready to Plug Into Your Present Radio Set

The "Aero-Call" 1929 Converter is a compact factory-built short-wave adapter equipped with special short-wave coils. It is designed for both A.C. and D.C. Sets. Operates perfectly on all sets without motorboating, by an auxiliary filter system control, an exclusive feature (patent applied for). It can be plugged into any regular radio set. This amazing radio instrument now makes it possible for you to reach 'round the world—England, Germany, Holland, Australia, Panama, Java and many foreign stations are some that are tuned in regularly on short wave. Permits you to enjoy international programs and many others from coast-to-coast that your regular receiver cannot get. What a thrill it is to plug this into a tube socket on your regular set and instantly be in another world! No change or wiring required. All complete, ready to operate, tubes and coils hidden, no apparatus in sight, except the neat, golden-brown, compact metal cabinet in crackle finish. Size 9x5 1/2 x 2 1/4 in. The only converter we know of that really works on all sets. Two models—A.C. and D.C. Secure it from your dealer or order direct, giving dealer's name. Dealers and Jobbers write for literature and prices.

Model A, for A.C. sets—\$25.00

Model D, for D.C. sets—\$25.00

**AERO PRODUCTS, Incorporated**  
4611 E. Ravenswood Ave., Dept. 2239, Chicago, U. S. A.

## Ashland Radio Laboratory

F. J. Kempf C.M.R., Specialist on Super-Hetrodyne's Authorized Sales and Service Station for Silver-Marshall Radio products, Scott World's Record Shield Grid Nine, HFL Special Nine and HFL Isotone, All HFL sets sold at 40% off list price. Expert service on all makes of sets. Guaranteed Radio Service. Reasonable Prices.

411 S. Ashland Blvd.

Phone Haymarket 5826

## SAVOY HOTEL - DETROIT

Woodward at Adelaide

750 Quiet Restful Rooms  
Each With Bath

SINGLE — \$2.50 to \$4.00 Per Day  
DOUBLE — \$4.00 to \$5.50 Per Day

SLEEPING ROOMS in the SAVOY HOTEL are CORRECT in APPOINTMENTS and INVITINGLY SPACIOUS. AT A VERY MODERATE PRICE. YOU MAY CHOOSE PRACTICALLY ANY SORT OF ACCOMMODATION.

# Letters That Reach the Editorial Desk

(Continued from page 48)

Rock, Ark., was assisted in reproducing the picture of Mr. Nockels standing before the microphone and that of the new station to be built near Downers Grove, Ill.

This from O. S. Figard and wife, Altoona, Pa.: "We are again sending congratulations on reception of programs from station WCFL. We are pleased to say we are able to tune in several times weekly. Your programs are all clear and appreciated by all. We are deeply interested in radio and hope for your continued success."

The high cost of freighting probably prevented Mr. Nick Weiner of 1918 Cleveland avenue, Chicago, from getting from some farmer "a dozen hens at a low price." When he wrote to the editor about the matter the best he could do was to discourage Mr. Weiner from his undertaking. Producer-to-consumer dealing has many difficulties.

In subscribing for WCFL Radio Magazine, Carl O. Zech of Grand Rapids, Mich., mentions at length that they got acquainted with television through WCFL station experimental tests. The first one was clear and strong. "Our Federal Ortho-Sonia has brought receptions into our home from 310 stations during its first year and five months. Nineteen of these stations are outside the United States."

## REPORTS SIGNALS SHARP AND CLEAR

Earl Woolcott, secretary of the local union of International Brotherhood of Electrical Workers at Duluth, Minn., told of purchasing a radio set to put in the hall for entertainment and asked advice as to which was the best equipment to buy. Then this: "We are receiving some wonderful programs from WCFL. We are constant boosters for your success."

Sending a dollar to be "put where it will do the most good for the laboring man and his family," Charles Brehany of Middletown, O., continues his good work by telling us that WCFL Radio Magazine is the best of its kind on the market. His dollar went to the maintenance fund of WCFL station, where other dollars sent by warm friends of the cause go. His example is warmly commended.

Successful television broadcasts by WCFL caused H. E. Burket, 810 Center Street, Chicago, to take his typewriter in hand. After ordering the magazine Mr. Burket asked for additional information as to television broadcasts. He wrote that the signals were very sharp and clear. As an amateur experimenter Mr. Burket was asked to keep us fully informed as to his progress.

The Signalman's Journal, a paper devoted to the interests of the workers in that branch of railroad service, asked, through Secretary Austin, permission to republish the article, entitled "Radio Speeds Operation of Trains." Mr. Austin was promptly favored, and, in addition, the engravings were supplied him.

Who invented the radio? It looks like some light on this interesting question was disclosed in a letter received from R. T. Stevens, 5316 Thirty-ninth Ave. So., Minneapolis, Minn., member of the International Brotherhood of Electrical Workers No. 292.

According to Mr. Stevens, Mr. Beck of Minneapolis applied for a patent in 1900 on the four-element vacuum tube and specified an amalgamated plate and thoriated

filament, also a shielded grid. "Of course, this sounds foolish," says Mr. Stevens, "but nevertheless I have seen photostat copies of his original application. He has tried to have his statement as his claim published in several magazines but they turned him down. The examiner at that time turned him down with the statement that such a thing was impossible. He does not expect to make a cent out of this but he does believe radio should be public property instead of paying royalties to the R. C. A. or DeForest. The latter's application filed in 1907 is the same as Beck's filed in 1900. Mr. Beck is bringing out a new tube which does not use a vacuum or any glass; it is made of copper, about the size of a match, also a battery which is nearly permanent and of very small size."

## Junior Program Expanding

THE program of the Junior Federation is expanding so rapidly that it is difficult to keep up with it, especially in a quarterly publication such as WCFL Radio Magazine. Started on November 1<sup>st</sup> without any preliminary announcement, the club at once sprang into prominence and was soon the leading juvenile feature of radio.

An article on page 27 tells of the important work the club is doing, especially in connection with the Chicago schools. Just recently other very splendid features have been added. Everyone seems not only willing but anxious to co-operate.

The Boys Club of Chicago is participating in a lively way. This club is a strong organization, having for its splendid objective the relief of the under-privileged boys of this great city. For these boys the club maintains three large club houses and carries on an active and varied program. The work is made possible through the generosity of men and women of means who have not forgotten that not so long ago they were youngsters. The Boys club puts on a little program over WCFL each Monday afternoon and also participates occasionally in the Junior hour.

A still later feature is the Safety talk at 4:30 each Tuesday afternoon by Alderman Thomas J. Bowler of the Forty-first ward. Alderman Bowler, a leader in the city council to which he was just recently re-elected, is the originator of the splendid lessons on safety that are presented in the Chicago schools. Mr. Bowler is a member of the Street Carmen's union and, no doubt, his inspiration to write lessons on safety for children was gained through his long service on the street cars. At any rate, he is a recognized authority on the teaching of safety to children, and his talks are an appreciated addition to the worth-while program of the Junior Federation.

Another feature of the Junior Federation program is the free course in radio now available to all readers of WCFL Radio Magazine. Singularly enough this free course in radio seems to be even more popular with the grownups than with the youngsters. But then, we are all young so long as we are not too old to learn. If you are interested in this free course, fill out the Business Reply Postal Card on page 3 and mail it today. No stamp is required.



# Some Friendly Words in Behalf of Hypocrites

(Continued from page 50)

propose to do about the babes who ask so many questions they have no right to ask? What about the gorgeous myths of goblins, fairies, Santa Claus and the stork? Must our offspring be fed with solemn truth from infancy instead of being given a few deluded years to have a good time?

A no less authority than Edwin E. Slosson, Ph. D., LL.D., argues that often it is well to assume a virtue if you have it not. "To profess moral health is unquestionably more wholesome than to assume moral disease. A man who sets up a false reputation for himself may by that means acquire a real character. The pretense may become an actuality, the fiction become a fact."

Jules de Gaultier, a French philosopher, has built up an ethical system based upon the assumption that hypocrisy is not a vice but a virtue, in fact, the chief of virtues, since it is only by means of it that moral advance has been made. According to this theory man sets himself up as a model of what he would like to be and does in that way come nearer to his ideal than he was or than he otherwise would be. By the same token a nation that believes itself, however erroneously, the most courageous or enterprising people of the world may in the course of time actually become such. Herein may lie the justification for the current belief that one average American is able to lick two Englishmen, five Frogs, a dozen Wops and a half acre of Japs. It may also turn out to the surprise of the thirsty and disgruntled that we will become a nation of total abstainers because of the Eighteenth amendment. For Gaultier says: "It is by

means of the power of affirmation, of assuming an ideal and so converting it into reality that man has made all his moral progress."

"Will to Believe," by James, is devoted to showing how unrealities may be made actualities if we desire them strongly enough and have faith in their possibility. Vaihinger in his philosophy of "As If" elaborates this theory of social progress.

As Dr. Raymond Pearl of Johns Hopkins University points out, no one would think of reproving a child because he dresses up as a cowboy or policeman. Every child knows that make-believe is a lot more fun than dull, sordid, cold reality. If anyone knows a better justification for sham than that, let him point it out.

One may be somewhat skeptical of the theories set forth by the before mentioned learned men, if he chooses. In his inquiries as to place and purpose of lies in this moral universe he may at least rest safely on the everyday observation that they add mightily to the pleasures of living.

## Closer Than Your Hangnail

"But he wouldn't go to court for six dollars!"

"Sure he would—he's the guy that sued his uncle for sending a telegram collect."

You can answer any advertisement in this issue of WCFL Radio Magazine merely by filling in the Business Reply Postal Card on page 3. No stamp is required.

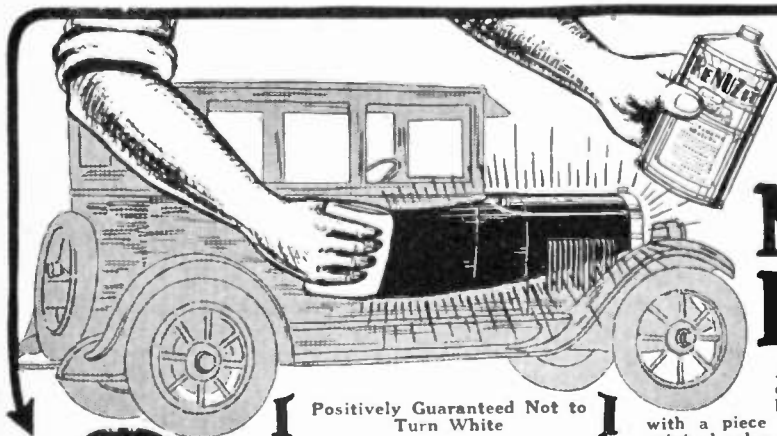

## 30 MINUTES AND RENUZIT Makes Old Cars Look Like New!

An amazing Fluid has now been perfected that transforms old, shabby looking cars into smartly shining new ones in half an hour! You just flow ReNUZit onto any automobile with a piece of cheesecloth and—almost miraculously it seems!—the original color and luster of that car gleam like new again.

## Brand New -- Different

Now the expense of re-paint jobs and the hard work of constantly polishing cars can be absolutely done away with. Never confuse ReNUZit with ordinary paints or varnishes—its principle is entirely different. Its cost is small in comparison. It is superior by far because one coat brings back the glowing beauty that wins admiration for the snappy well-kept motor car. Millions of car owners have been waiting for it.

## Simple to Apply as A-B-C

There's no tiresome rubbing or polishing with ReNUZit. It just flows on—dries almost immediately. Harmless—Lasting—Sure. No trouble—no bother—no mess. The new perfected ReNUZit is positively guaranteed not to turn white. It is absolutely harmless. PRESERVES the surface as it forms a protective coat that resists harmful chemicals. Washing only serves to harden the ReNUZit surface and makes it even more brilliant.

## Try ReNUZit FREE

We give you the privilege of testing ReNUZit right now without risk or obligation. Prove to yourself what a transformation it accomplishes with an old, faded, dull surface. See your own or a friend's car brought back to its original show-room beauty. Mail coupon quick for full details and Free Trial Offer.

**The ReNUZit System, 154 E. Erie St., Dept. 977-B.R. Chicago, Ill.**

## AGENTS—Make \$200.00 a Week Easy

Full or spare time—you can make big money with ReNUZit. Just consider the enormous market. For every one of the thousands of new cars on the streets today there are at least 20 OLD ones—and more are losing the bloom of youth every day. One short, convincing demonstration of ReNUZit shows owners of old cars what it can do. It doesn't require high powered selling to make handsome profits with ReNUZit—its results are all the argument you need. And our new agent's proposition is so GOOD you should have no trouble making \$200.00 and up a week. Get started At Once!

THE RENUZIT SYSTEM,  
154 E. Erie St.,  
Dept. 977-B.R., Chicago, Ill.

Rush full information on ReNUZit, with Free Trial Offer, and Agent's new plan on how I can make \$200.00 and up a week. No obligation.

Name .....  
Address .....  
City ..... State .....

Postage Free—You can answer the above advertisement without buying a stamp—See page 3

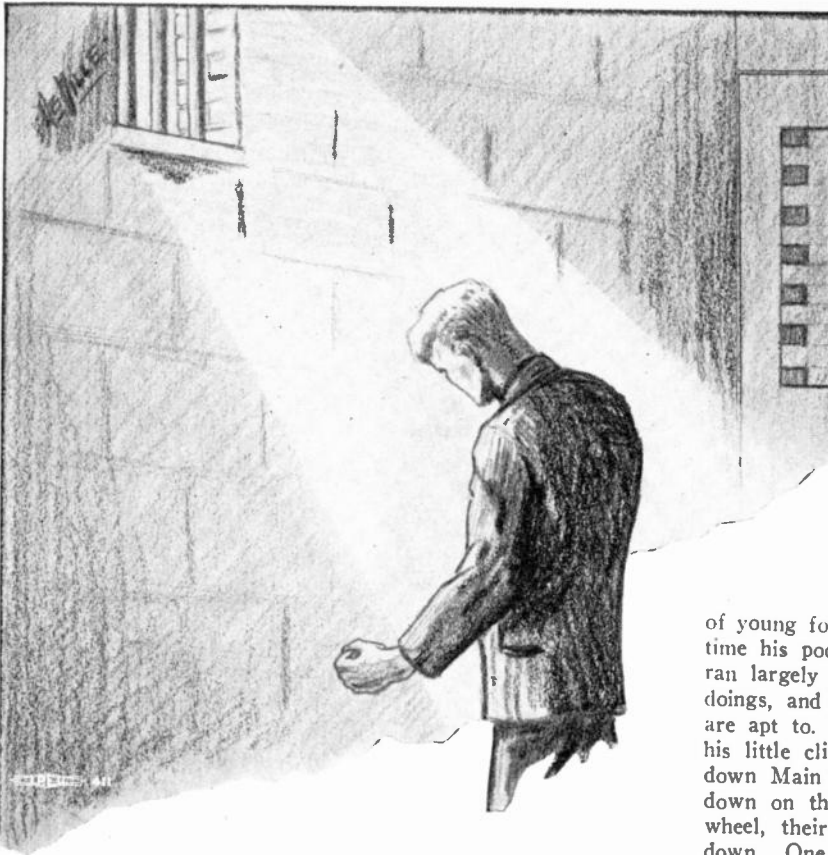

Did my three years in prison kill mother?

**T**HERE are two ways of doing battle against Disgrace. You may live it down; or you may run away from it and hide. The first method is heart-breaking, but sure. The second cannot be relied upon because of the uncomfortable way Disgrace has of turning up at your heels just when you think you have eluded her in the last town but one.

Ted Terrill did not choose the first method. He had it thrust upon him. After Ted had served his term he came back home to visit his mother's grave, intending to take the next train out. He wore none of the prison pallor that you read about in books, because he had been shortstop on the penitentiary all-star baseball team, and famed for the dexterity with which he could grab up red-hot grounders. The storied lock step and the clipped hair effect also were missing. The superintendent of Ted's prison had been one of the reform kind.

You never would have picked Ted for a criminal. He had none of those interesting phrenological bumps and depressions that usually are shown to such frank advantage in the Bertillon photographs. Ted had been assistant cashier in the Citizens' National Bank. In a mad moment he had attempted a little sleight-of-hand act in which certain Citizens' National funds were to be transformed into certain glittering shares and back again so quickly that the examiners couldn't follow it with their eyes. But Ted was unaccustomed to these now-you-see-it-and-now-you-don't feats and his hand slipped. The trick dropped to the floor with an awful clatter.

Ted had been a lovable young kid, six feet high, and blonde, with a great reputation as a dresser. He had the first yellow plush hat in our town. It sat on his golden head like a halo. The women all liked Ted. Mrs. Dankworth, the dashing widow (why will widows persist in being dashing?), said that he was the only man in our town who knew how to wear a dress suit. The men were forever slapping him on the back and asking him to have a little something. Ted's good looks, and his clever tongue and a certain charming Irish way he had with him caused him to be taken up by the smart set. Now, if you've never lived in a small town you will be much amused at the idea of its boasting a smart set. Which proves your ignorance. The small town smart set is deadly serious about its smartness. It likes to make six-hour runs down to the city to fit a pair of shoes and hear Galli-Curci. Its clothes are as well made, and its scandals as crisp, and its pace as hasty, and its golf club as dull as the clothes, scandals, and pace, and golf club of its city cousins.

The hasty pace killed Ted. He tried to keep step in a set

# The Man Who Came Back

By EDNA FERBER

of young folks whose fathers had made our town. And all the time his pocketbook was yelling, "Whoa!" The young people ran largely to scarlet-upholstered sport cars, and country-club doings, and house parties, as small town younger generations are apt to. When Ted went to high school half the boys in his little clique spent their after-school hours dashing up and down Main street in their big, glittering cars, sitting slumped down on the middle of their spines in front of the steering wheel, their sleeves rolled up, their hair smoothly plastered down. One or the other of them always took Ted along. It is fearfully easy to develop a taste for that kind of thing. As he grew older, the taste took root and became a habit.

Ted came out after serving his term, still handsome, spite of all that story writers may have taught to the contrary. But we'll make this concession to the old tradition. There was a difference. His radiant blondeur was dimmed in some intangible, elusive way. Birdie Callahan, who had worked in Ted's mother's kitchen for years, and who had gone back to her old job at the Haley House after her mistress' death, put it sadly, thus:

"He was always th' han'some divil. I used to look forward to ironin' day just for the pleasure of pressin' his fancy shirts for him. I'm that partial to them swell blondes. But I dinnaw, he's changed. Doin' time has taken the edge off his hair an' complexion. Not changed his color, do you mind, but dulled it, like a gold ring, or the like that has tarnished."

Ted was seated in the smoker, with a chip on his shoulder, and a sick horror of encountering some one he knew in his heart, when Jo Haley, of the Haley House, got on at Westport, homeward bound. Jo Haley is the most eligible bachelor in our town, and the slipperiest. He has made the Haley House a gem, so that traveling men will cut half a dozen towns to Sunday there. If he should say "Jump through this!" to any girl in our town she'd jump.

Jo Haley strolled leisurely up the car aisle toward Ted. Ted saw him coming and sat very still, waiting.

"Hello Ted! How's Ted?" said Jo Haley, casually. And dropped into the adjoining seat without any more fuss.

Ted wet his lips slightly and tried to say something. He had been a breezy talker. But the words would not come. Jo Haley made no effort to cover the situation with a rush of conversation. He did not seem to realize that there was any situation to cover. He champed the end of his cigar and handed one to Ted.

"Well, you've taken your lickin', kid. What you going to do now?"

The rawness of it made Ted wince.

"Oh, I don't know," he stammered. "I've a job half promised in Chicago."

"What doing?"

Ted laughed a short and ugly laugh. "Driving an auto truck?"

Joe Haley tossed his cigar dexterously to the opposite corner of his mouth and squinted thoughtfully along its bulging sides.

"Remember that Wenzel girl that's kept books for me for the last six years? She's leaving in a couple of months to marry a New York guy that travels for ladies' cloaks and suits. After she goes it's nix with the lady bookkeepers for me.

Not that Minnie isn't a good, straight girl, and honest, but no girl can keep books with one eye on a column of figures and the other on a traveling man in a brown suit and red necktie, unless she's cross-eyed, and you bet Minnie ain't. The job's your's, if you want it. A hundred and fifty a month to start on, and board.

"I—can't, Joe. Thanks just the same. I'm going to try to begin all over again, somewhere else, where nobody knows me."

"Oh, yes," said Jo. "I knew a fellow that did that. After he came out he grew a beard, and wore eyeglasses, and changed his name. Had a quick, crisp way of talkin', and he cultivated a drawl and went west and started in business. Real estate, I think. Anyway, the second month he was there in walks a fool he used to know and bellows: 'Why if it ain't Bill! Hello Bill! I thought you was doing time yet.' That was enough. Ted, you can black your face, and dye your hair, and squint and some fine day, sooner or later, somebody'll come along and blab the whole thing. And say, the older it gets the worse it sounds, when it does come out. Stick around here where you grew up, Ted."

Ted clasped and unclasped his hands uncomfortably. "I can't figure out why you should care how I finish."

"No reason," answer Jo. "Not a darned one. I wasn't ever in love with your ma, like the guy on the stage; and I never owed your pa a cent. So it ain't a guilty conscience. I guess it's just pure cussedness, and a hankerin' for a new investment. I'm curious to know how you'll turn out. You've got the makin's of what the newspapers call a Leading Citizen, even if you did fall down once. If I'd ever had time to get married, which I never will have, a first-class hotel bein' more worry and expense than a bootlegger's whole harem, I'd have wanted somebody to do the same for my kid. That sounds slushy, but it's straight."

"I don't seem to know how to thank you," began Ted a little husky as to voice.

"Call around tomorrow morning," interrupted Jo Haley, briskly, "and Minnie Wenzel will show you the ropes. You and her can work together for a couple of months. After then she's leaving to make her underwear, and all that. I should think she'd have a bale of it by this time. Been embroidering them shimmy things and lunch cloths back of the desk when she thought I wasn't lookin' for the last six months."

Ted came down next morning at 8 a. m. with his nerve between his teeth and the chip still balanced lightly on his shoulder. Five minutes later Minnie Wenzel knocked it off. When Jo Haley introduced the two jocularly, knowing that they had originally met in the First Reader room, Miss Wenzel acknowledged the introduction icily by lifting her left eyebrow slightly and drawing down the corners of her mouth. Her air of hauteur was a triumph, considering that she was handicapped by black sateen sleevelets.

I wonder how one could best describe Miss Wenzel? There is one of her in every small town. Let me think—(business of hand on brow). Well, she always paid five dollars for her nude chiffons when most girls in a similar position got their stockings for ninety-five cents in the basement. Nature had been kind to her. The hair that had been a muddy brown in Minnie's schoolgirl days it had touched with a magic red-gold wand. Birdie Callahan always said that Minnie was working only to wear out her old clothes.

After the introduction Miss Wenzel followed Jo Haley into the lobby. She took no pains to lower her voice.

"Well I must say, Mr. Haley, you've got a fine nerve! If my gentleman friend was to hear of my working with an ex-con I wouldn't be surprised if he'd break off the engagement. I should like you'd have some respect for the feelings of a lady with a name to keep up, and engaged to a swell fellow like Mr. Schwartz."

"Say, listen m' girl," replied Joe Haley. "The law don't cover all the tricks. But if stuffing an order was a criminal offense I'll bet your swell traveling man would be doing a life term."

Ted worked that day with his teeth set so that his jaws ached next morning. Minnie Wenzel spoke to him only when necessary and then in terms of dollars and cents. When dinner time came she divested herself of the black sateen sleevelets, wriggled from the shoulders down a la Gilda Gray, produced a powder puff, and disappeared in the direction of the washroom. Ted waited until the dining room was almost deserted. Then

he went in to dinner alone. Some one in white wearing an absurd little pocket handkerchief of an apron led him to a seat in a far corner of the big room. Ted did not lift his eyes higher than the snowy square of the apron. The Apron drew out a chair, shoved it under Ted's knees in the way Aprons have, and thrust a printed menu at him.

"Roast beef, medium," said Ted, without looking up.

"Bless your heart, you ain't changed a bit. I remember how yuh used to jaw when it was too well done," said the Apron fondly.

Ted's head came up with a jerk.

"So yuh will cut yer old friends, is it?" grinned Birdie Callahan. "If this wasn't a public dining room maybe yuh'd shake hands with a poor but proud workin' girrul. Yer as good lookin' a divil as ever, Mister Ted."

Ted's hand shot out and grasped hers. "Birdie! I could weep on your apron! I never was so glad to see anyone in my life. Just to look at you makes me homesick. What in Sam Hill are you doing here?"

"Waitin'. After yer ma died, seemed like I didn't care t' work fer no other privit fam'ly, so I came back here to my old job. I'll bet I'm the homeliest head waitress in captivity."



Ted, ashamed, gave thanks that she was dead

Ted's nervous fingers were pleating the tablecloth. His voice sank to a whisper. "Birdie, tell me the God's truth. Did those three years cause her death?"

"Nivir!" lied Birdie. "I was with her to the end. It started with a cold on th' chest. Have some French fried with yer beef, Mr. Teddy. They're illigent today."

Birdie glided off to the kitchen. Authors are fond of the word "glide." But you can take it literally this time. Birdie had a face that looked like a huge mistake, but she walked like a panther, and they're said to be the last cry in gliders. She walked with her chin up and her hips firm. That comes from juggling trays. You have to walk like that to keep your nose out of the soup. After a while the walk becomes a habit. Any seasoned dining-room girl could give lessons in walking to the gym teacher of an eastern finishing school.

From the day that Birdie Callahan served Ted with the roast beef medium and the elegant French fried, she appointed herself monitor over his food and clothes and morals. I wish I

(Continued on page 70)

# On the Road to the Spirits' Abode

(Continued from page 54)

Says David Starr Jordan: "War lifted the lid on society and secret actions and beliefs danced openly on the green. We see the magic wand used on both sides of the line to find water. Books in defense of its powers were published in 1920 and the next year the French Academy of Sciences appointed a committee to study this pagan practice called rhabdomancy. A weekly periodical devoted to the art was launched in Germany. Much employed in the United States are the forked twig of witch hazel and the more pretentious divining rods to discover water, oil, gold and lost articles. In post-war England, bereft of many sons, spiritism has a horde of followers.

Demonology appears to have made victims of American missionaries sent to China and Korea. Instead of converting the heathen the missionaries themselves have been perverted to a belief in devil possession and bear testimony to the efficacy of exorcism.

In a recent trial in France personal testimony and experimental evidence brought forward in court to show that the accused had killed people by sticking pins into their wax figures. Satan worship has become a cult and the Black Mass is celebrated in Paris.

Learned men in Germany are foretelling the near end of the world. They send out pamphlets showing in color the sun streaked with blood and the moon darkened. From one end of the new republic to the other various isms and crazes are overwhelmed with followers.

While the steam age routed most of the superstitions cherished by deep sea sailors, the mariner still clings to a few beliefs in signs and omens. Thus, if a captain meets a pig before he reaches dock, he does not like to sail that day no matter how favorable the weather might be.

Disconcerting to those anxious to put down superstition

is that the machinery of science may be employed to defeat the aims of science. The printing press contributes to the propagation of delusions and obscurantism as well as to the promulgation of truth. Radio has given Voliva a chance to broadcast all around the globe his gospel of a flat earth. Radio also affords a new form of ancient divination. Instead of opening by chance a volume of Shakespeare or the Bible and taking the first passage the eye lights on as a message from heaven, the up-to-date occultist, when in doubt or distress, goes to the radio receiver with eyes shut and turns the dials till he or she hears a fragment of a speech or song that may be interpreted as an answer to the problem or a guide to action in some important matter.

Still, some progress has undoubtedly been made in chasing out of intellectual garrets the rats, bats and owls. We no longer hang witches for planting a glove in a haunted wood in the dark of the moon in order that the owner of the grove come down with gallstones or cirrhosis of the liver, and fewer babies born in 1928 were hurried to the attic immediately after weighing in in order to rise in the world later on.

When modern science began its expanding work it found that spirits of many kinds were supposed to be at work in and around the human body. Pasteur discovered that the malignant spirits of disease were, for the most part, material organisms; malignant devils that seized men became known as "Jacksonian epilepsies" the "vital spirits" of the blood were found to be oxygen. Science is driving spirits from the body. Sooner or later it will expel all of them, for as knowledge improves we find that what were spirits in the eyes of our fathers and mothers are actual substances to our vision.

## WIFE WINS FREEDOM FROM NEURITIS

*Couldn't Work for Five Weeks—One  
Trial of Nurito Puts Her On Her Feet*

### DRUGGISTS GUARANTEE NURITO

The New York Specialist who discovered Nurito now has made it available to everybody through neighborhood drug stores. Thousands have discovered this magic relief from neuritis, rheumatism, sciatica, lumbago, and neuralgia. So certain are results that if Nurito doesn't drive away the pain in a few doses, your druggist will refund your money without question. And out of 20,000 boxes sold recently, only three people reported failure to get relief—an astounding record. Nurito works different than any other treatment in the world. For it contains no narcotics or opiates and is absolutely harmless even to children.

Why suffer a single hour of unnecessary pain? Let your druggist tell you about this internationally famous Nurito, that drives away torture and enables you to work in peace. Delay only causes you suffering. Try Nurito today.

If your druggist cannot supply you send \$1.00 direct to Nurito Company for regular size package. Your money back if first few doses do not relieve your pain.

**NURITO COMPANY**

**225 N. Michigan Ave., Chicago, Illinois**

Postage Free—You can get full information regarding the above advertisement without buying a postage stamp—See page 3

# Radio Controls the Nation

(Continued from page 56)

message for all mankind. It asks no monopoly, no special privilege, no right to exploit the air for commercial profit. It asks only that it be allowed to use one of the 89 available radio channels in order that it may freely promulgate its principles and ideals and thereby protect and serve the entire public.

Surely it is in the "public interest, necessity and convenience" that this unparalleled means of communication be kept as a sacred heritage for all posterity; that it be not controlled or dominated by any class or group, but rather that every reputable group shall have opportunity to sing its song, tell its story or proclaim its message to those who desire to hear.

Station WCFL has asked for an exclusive channel on which to operate its proposed 50,000 watt station for which a building permit has been issued. If this request shall be granted, it is intended to erect one of the best stations in the country, and to offer a program of music, entertainment, education and inspiration second to none.

We have also asked for the use of a short wave channel to be used in re-broadcasting WCFL programs to substations to be erected in various parts of the country, from which the programs will then be re-broadcast on the same wavelength as WCFL. By this system we can send our programs into every part of the country without interfering with any other station, and shall serve, on one broadcast channel, practically the entire nation. This is a step far in advance of the present practice whereby a nationwide hookup requires the use of 30 or 40 channels.

In addition to all of the foregoing, it is an impressive fact that the Farmers' Educational and Cooperative Union of America, with affiliated Farmers Unions in many states, have entered into a contract with us to participate in the program offerings of WCFL, and to contribute, on a per capita basis, to its support. In this way, the farmers of the country will be served by this station more fully and efficiently than by any other radio station. Altogether, it is not too much to say that when WCFL has completed its broad program (already approved by the best radio engineers in the country), it will serve, with a high degree of efficiency, several times as many people as any other radio station in the world. It is the only radio station in America built and supported by the listeners themselves. It is the only station in the world owned and operated by organized Labor.

## Labor Seeks Only Radio Equality

(Continued from page 58)

If cleared channels are to be granted to corporations, then Organized Labor, with millions of members and a real message for the world, wants a cleared channel. But we believe excessive power and many cleared channels are not in the public interest. They are in the interest of the corporation that owns them; they add to its power and prestige; they help to smother and destroy other stations; they bring good advertising contracts. But they are not in the public interest, as they are now being operated, and in the present state of the art, and with private competitive conditions as they now exist in the industry. We do not say there should not, under any circumstances, be cleared channels and high power. It is probably desirable that there should be a few such stations; but we think they should be very few, and that exceptional care should be taken to make sure they are established and operated "in the public interest, convenience and necessity," in the truest and broadest meaning of that clause of the statute.

We are ready to abandon our own high-powered station, even after it is built, and to accept part time with other stations, provided all are treated alike.

We believe the demand for ever greater and greater power will continue. Applications are now pending for 100,000 and 150,000 watts of power. We think it is monopolistic, inefficient, unnecessary, unfair to other broadcasters and to the public.

In our judgment, and with all due respect for experts and radio engineers, the public will be better served throughout the years, if the number of cleared channels shall be greatly reduced, and the power of all, or nearly all stations, limited to relatively low wattage.

This statement is made as applying to the present state of the art, and the present competitive conditions in the industry. Changes in either of these may justify cleared channels and high power.

Even if it could be scientifically demonstrated, which we think has not yet been done, that cleared channels and high power afford great efficiency in the aggregate use of the limited radio facilities, still there remains the question as to whether or not a more than compensating loss may result from monopolistic control, from centralizing the source of radio programs, from depriving many communities, groups and fields of interest of any opportunity for self-expression. Efficiency may take too great a toll.

## Use the Mails Without Cost

Only members of Congress and other government officials are supposed to be able to use the U. S. Mails without paying postage. However, WCFL Radio Magazine has made a clever adaptation of a recent postal regulation which makes it possible for you to enjoy the privilege of using the mails without paying postage. See the Business Reply Postal Cards on page 3.

# Solving the X Resistance

For that uncertain resistance in the circuit — uncertain because of uncertain signal strength, fluctuating voltage, variations in tubes, and other unknown factors — turn to the CLAROSTAT as the solution of the X resistance. A turn of the knob or screw, and you have the precise resistance value. No guessing. No mathematics. No nerve-wrecking formulas. No crude makeshifts. No uncertain results. And don't forget: There's a CLAROSTAT for every Radio Purpose—



For use in the radio assembly itself, there's the Grid Leak, Volume Control, Standard and Power CLAROSTATS, with knob for easy adjustment of resistance.

For semi-permanent resistance, in the radio set or power unit, there's the Duplex CLAROSTAT, instantly adjustable with a screw-driver, yet free from meddling.



For external use in controlling volume, tone or sensitivity of radio set or phonograph pick-up, there's the handy Table Type CLAROSTAT, and the heavier Speed Control CLAROSTAT for motor and television uses.

In many styles, sizes, mountings and ranges, the CLAROSTAT is a truly universal resistance that takes the guesswork out of radio. Whether your set is being planned or is already built, new or old, manufactured or home-made, good or bad, or indifferent — the CLAROSTAT, properly applied, will make it a better set.

**CLAROSTAT MFG. Co., Inc.**  
Specialists in Radio Aids,  
290 N. 6th St.  
Brooklyn,  
N. Y.

WRITE for data on the complete line of CLAROSTAT products and how to apply them. Better still, send 25 cents for the "Gateway to Better Radio"; a 32-page book with 20,000 words and 88 illustrations. Invaluable to every radio fan!

# The Man Who Came Back

(Continued from page 67)

could find words to describe his bitter loneliness. He did not seek companionship. The men, although not directly avoiding him, seemed somehow to have pressing business whenever they happened in his vicinity. The women ignored him. Mrs. Dankworth, still dashing and still widowed, passed Ted one day and looked fixedly at a point one inch above his head. In a town like ours the Haley House is like a big, hospitable clubhouse. The men drop in there the first thing in the morning, and the last thing at night, to hear the gossip and buy a cigar and jolly the girl at the cigar counter. Ted spoke to them when they spoke to him. He began to develop a certain grim line about the mouth. Jo Haley watched him from afar, and the longer he watched the kinder and more speculative grew the look in his eyes. And slowly and surely there grew in the hearts of our townspeople a certain new respect and admiration for this boy who was fighting his fight.

Ted got into the habit of taking his meals late, so that Birdie Callahan could take the time to talk to him.

"Birdie," he said one day, when she brought his soup, "do you know you're the only decent woman who'll talk to me? Do you know what I mean when I say that I'd give the rest of my life if I could just put my head in my mother's lap and have her muss up my hair and call me foolish names?"

Birdie Callahan cleared her throat and said abruptly: "I was noticin' yesterday your gray pants needs pressin' bad. Bring 'em down tomorrow mornin' and I'll give 'em th' elegant crease in the laundry."

So the first weeks went by, and the two months of Miss Wenzel's stay came to an end. Ted thanked his God and tried hard not to wish that she was a man so that he could punch her head.

The day before the time appointed for her departure she was closeted with Jo Haley for a long, long time. When finally she emerged a bellboy lounged up to Ted with a message.

"Wenzel says th' Old Man wants t' see you. 'S in his office. Say, Mr. Terrill, do yuh think they can play today? It's pretty wet."

Jo Haley was sunk in the depths of his big leather chair. He did not look up as Ted entered. "Sit down," he said. Ted sat down and waited, puzzled.

"As a wizard at figures," mused Jo Haley at last, softly as though to himself, "I'm a frost. A column of figures on paper makes my head swim. But I can carry a whole regiment of them in my head. I've been watchin' this thing for the last two weeks hopin' you'd quit and come and tell me." He turned suddenly and faced Ted. "Ted, old kid," he said sadly, "what-n' 'ell made you do it again?"

"What's the joke?" asked Ted.

"Now, Ted," remonstrated Jo Haley, "that way of talking won't help matters none. As I said, I'm rotten at figures. But you're the first investment that ever turned out bad and let me tell you I've handled some mighty bad smelling ones. Why, kid, if you had just come to me on the quiet and asked for the loan of a hundred or so why—"

"What's the joke, Jo?" said Ted again, slowly.

"This ain't my notion of a joke," came the terse answer. "We're three hundred short."

The last vestige of Ted Terrill's old-time radiance seemed to flicker and die, leaving him ashen and old.

"Short?" he repeated. Then "My God!" in a strangely colorless voice—"My God!" He looked down at his fingers impersonally, as though they belonged to some one else. Then his hand clutched Jo Haley's arm with the grip of fear. "Jo! Jo! That's the thing that has haunted me day and night, till my nerves are raw. The fear of doing it again. Don't laugh at me, will you. I used to lie awake nights going over that cursed business of the bank—over and over—till the cold sweat would break out all over me. I used to figure it all out again, step by step, until—Jo, could a man steal and not know it? Could thinking of a thing like that drive a man crazy? Because if it could—if it could—then—"

"I don't know," said Jo Haley, "but it sounds darned fishy. He had a hand on Ted's shaking shoulder, and was looking into the white, drawn face. "I had great plans for you, Ted. But Minnie Wenzel's got it all down on slips of paper. I might

as well call her in again, and we'll have the whole blamed thing out."

Minnie Welzel came. In her hand were slips of paper, and books with figures in them, and Ted looked and saw things written in his own hand that should not have been there. And he covered his shamed face with his two hands and gave thanks that his mother was dead.

There came three sharp raps at the office door. The tense figures within jumped nervously.

"Keep out!" called Jo Haley, "whoever you are." Whereupon the door opened and Birdie Callahan breezed in.

"Get out, Birdie Callahan," roared Jo. "You're in the wrong pew."

Birdie closed the door behind her composedly and came farther into the room. "Pete th' pasthry cook just tells me that Minnie Welzel told the day clerk, who told th' janitor, who told th' chef, who told Pete, that Minnie had caught Ted stealin' some three hundred dollars."

Ted took a quick step forward. "Birdie, for Heaven's sake keep out of this. You can't make things any better. You may believe in me, but—"

"Where's the money?" asked Birdie.

Ted stared at her a moment, his mouth open ludicrously.

"Why—I—don't—know," he articulated, painfully. "I never thought of that."

Birdie snorted defiantly. "I thought so. D'ye know," socially, "I was visitin' with my aunt Mis' Mulcahy last evenin'."

There was a quick rustle of skirts from Minnie Wenzel's direction.

"Say, look here—" began Jo Haley, impatiently.

"Shut up, Jo Haley!" snapped Birdie. "As I was sayin' I was visitin' with my aunt Mis' Mulcahy. She does fancy washin' an' ironin' for swells. An' Minnie Wenzel, there bein' none sweller, hires her to do up her weddin' linens. Such smears av hand embridery she never see th' likes, Mis' Mulcahy says, and she's seen a lot. And as a special treat to the poor owld soul, why Minnie Wenzel lets her see some av her weddin' clo'es. There never yet was a woman who cud resist showin' her weddin' things to every other woman she cud lay hands on. Well, Mis' Mulcahy, she see that grand trewsew and she said she never saw th' beat. Dresses! Well, her going away suit alone comes to eighty dollars, for it's bein' made by Molkowsky, the little Polish tailor. An' her weddin' dress is satin, do you mind! Oh, it was a real treat for my aunt Mis' Mulcahy."

Birdie walked over to where Minnie Wenzel sat, very white and still, and pointed a stubby red finger in her face. "'Tis the grand manager ye are, Miss Wenzel, gettin' satins an' tailor mades on yer salary. It takes a woman, Minnie Wenzel, too see through a woman's tricks."

"Well I'll be dinged!" exploded Jo Haley.

"Yuh'd better be!" retorted Birdie Callahan.

Minnie Wenzel stood up, her lip caught between her teeth.

"Am I to understand, Jo Haley, that you dare to accuse me of taking your filthy money, instead of that miserable ex-con there who has done time?"

"That'll do, Minnie," said Jo Haley, gently. "That's aplenty."

"Prove it," went on Minnie, and then looked as though she wished she hadn't.

"A business college edjication is a grand foine thing," observed Birdie. "Miss Wenzel is a graduate av wan. They teach you everything from drawin' birds with tail feathers to plain and fancy penmanship. In fact, they teach everything in the writin' line except forgery, an' I ain't so sure they haven't got a coorse in that."

"I don't care," whimpered Minnie Wenzel suddenly, sinking in a limp heap on the floor. "I had to do it. I'm marrying a swell fellow and a girl's got to have some clothes that don't look like a hick dressmaker's work. He's got three sisters. I saw their pictures and they're coming to the wedding. They're the kind that wear ball gowns in the evening, and have their hair and nails done downtown. I haven't got a thing but my looks. Could I go to New York dressed like a rube? On the square, Jo, I worked here six years and never took a sou. But things got away from me. The tailor wouldn't finish my suit unless I paid fifty dollars down. I only took fifty at first,

intending to pay it back. Honest to goodness, Joe, I did."

"Cut it out," said Jo Haley, "and get up. I was going to give you a check for your wedding, though I hadn't counted on no three hundred. We'll call it square. And I hope you'll be happy, but I don't gamble on it. You'll be goin' through your man's pants pockets before you're married a year. You can take your hat and fade. How I'm going to square this with Ted and Birdie."

"An' me standing here gassin' while them fool girls in the dinin' room can't set a table decent, and dinner in less than ten minutes," cried Birdie, rushing off. Ted mumbled something unintelligible and was after her.

"Birdie! I want to talk to you."

"Say it quick," said Birdie, over her shoulder. "Doors open in three minutes."

"I can't tell you how grateful I am. This is no place to talk. Will you let me walk home with you tonight?"

"Will I?" said Birdie, turning to face him. "I will not. The swell mob has shook you, and a good thing it is. You was travelin' with a bunch of racers, when you was only built for medium speed. Now you've got your chance for a fresh start and don't you ever think I'm going to be the one to let you spoil it by beginnin' to walk out with a dinin' room Lizzie like me."

"Don't say that, Birdie," Ted put in.

"It's the truth," affirmed Birdie. "Not that I ain't a perfectly respectable girrul, and ye know it. I'm a good slob, but folks would be tickled for the chance to say that you had nobody to go with but the likes av me. If I was to let you walk home with me tonight, you might be askin' to call next week. Inside half a year, if yuh was lonesome enough you'd ask me to marry yuh. And b'gorra," she said softly, looking down at her unlovely red hands. "I'm dead scared I'd do it. Get back to work, Ted Terrill, and hold yer head high, and when yuh say your prayers tonight, thank your lucky stars I ain't a hussy."

### Help Wanted

(Continued from page 62)

large cities have a Real Estate Board to look after such shady transactions? And do not real estate salesmen have to be licensed?"

Of course they have, and do, little dears. In the particular city of which I write, there is one of the most respected and well-organized real estate boards in the United States. It is headed by Mr. Smug. And the local Boosters' club lends a hand by running out of business any small operator who tries to cut in on the game of the big ones.

When the novice first undertakes real estate salesmanship he is called a bird dog. He locates the person willing to buy, gets a signed slip to the effect that he will indeed buy, some time, and then calls in one of the firm's real salesmen to close the deal. The real salesmen have licenses which cost two dollars.

# MAKE GOOD RECEPTION EASY

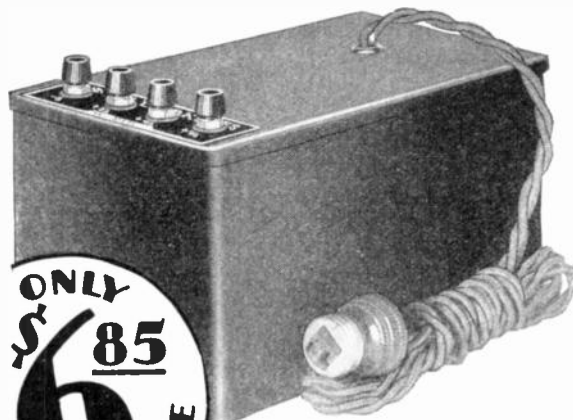

ONLY \$6.85 COMPLETE

## TOWNSEND "B" Power Unit

THOUSANDS of users marvel at the difference in reception with a Townsend "B" Power Unit. Full, sweet tone, clarity, volume and greater distance are among the many advantages reported daily.

Hooked up in a few minutes; just plug into the light socket and forget it. Delivers up to 100 volts on any set —D.C. or A.C.—any cycle.

### Over 100,000 Now in Use

There's no longer any reason for putting up with the expense, the inconvenience and undependable performance of "B" Batteries—when you can own a good "B" Power Unit for the surprisingly low cost of \$6.85. Over 100,000 Townsend "B" Power Units now in use—a substantial proof of satisfaction.

### Send Only \$1.00

Fill in coupon and send with only \$1.00. Prove this marvelous value to yourself. Use it ten days. Then, if it fails to do everything we say, return it and money paid us will be refunded. Make a REAL receiver of your set.

### Approved and Passed

by the rigid laboratory tests of "Popular Radio" and "Radio News."

**TOWNSEND LABORATORIES**  
Dept. 76  
713 Townsend St., Chicago, Ill.

### These Have— So Can YOU!

Eliminator is a wonder. Have had it almost three years and no trouble at all with it.  
Earl C. Brollier,  
Marble Park, Ia.

Have had Eliminator for two years and got the best of results from it.  
Chas. O. Snodgrass,  
Mingo Jct., Ohio.

Have used Eliminator for over a year and find no fault with it.  
Sgt. J. H. Zarling,  
Field Artillery School,  
Ft. Sill, Okla.

Have used your Eliminator for over a year and more than pleased with it.  
W. M. Schmidt,  
Santa Ana, Calif.

Eliminator working great. Worth its weight in gold.  
Henry W. Ernie,  
Wilkes-Barre, Pa.

Eliminator works just fine on my RCA. Gives me no trouble at all.  
A. D. McComas,  
St. Albans, W. Va.

Have used Eliminator for over a year with fine results.  
J. L. Davis, North Vernon, Ind.

Your Eliminator has held up fine.  
E. K. Walsh, Norfolk, Va.

Eliminator bought from you last winter is all that you claim it to be and more.  
P. M. Lauer, Alliance, Nebr.

Eliminator bought some time ago works just fine.  
Robert F. T. Preusse,  
Falls City, Nebr.

Have had Eliminator about a year and it sure has given good service.  
L. E. Fillingame, Waco, Texas.

Eliminator works wonderful on our GEBBE.  
Alex S. Stirling, Romeo, Mich.

**ATTACH ONLY \$1.00 TO THIS COUPON**

TOWNSEND LABORATORIES,  
Dept. 76,  
713 Townsend St.,  
Chicago, Ill.

2-29

Gentlemen:  
Attached find \$1.00. Kindly send at once Townsend "B" Socket Power Unit, C.O.D. \$5.85, plus postage, on guaranteed 10-day Free Trial.

Name .....

Address .....

City..... State.....

## Build The Screen Grid Find-All Four

Amazing results attained with this easily assembled four tube receiver. Large print containing picture, wiring diagram, schematic, front view, top view, etc., and complete list of parts, mailed postpaid for only 50c.

Two pamphlets, explaining receiver, with Constructional Directions, step-by-step wiring Instructions, etc., mailed postpaid, together with Large Print, \$1.00.

### ALLIED ENGINEERING INSTITUTE

Suite 429 30 Church Street NEW YORK, N. Y.

# Speaking of Cat's Whiskers - -



## Momentary Thrill

"Would it please you if I grew a moustache?"  
"It might tickle me temporarily."

## Form Fitting

Lady in Department Store: "May I get some trunks, please?"

Luggage Salesman: "Do you prefer the plain ones, Madam, or shall I show you some of our new metal trimmed, indestructible, camp or running board type?"

Lady: "Just plain ones, I guess. My husband wants to wear them in swimming."—*The Woodman Recorder.*

## Bye Bye All Around

"Two boys wanted to kiss me goodby at the station."  
"What did you do then?"  
"Introduced one to a girl friend."

"Is your landlady suspicious?"  
"Yes, every time I take out my laundry she thinks I'm going to move."

## Worse

"If you put wedding cake under your pillow you'll have a dream."  
"And if you put it under your belt you'll have a nightmare."

## Sufficient Reason

"Jenkins has gone into the discard, hasn't he?"  
"Yeh, he held onto a pair of queens too long."

## A Good Time All Over

"I envy that fat woman when she laughs."  
"Why?"  
"There seems to be so much of her having a good time."—*Wall Street Journal.*

## All Doped Out

"What are you going to be, little man?"  
"Flag-pole sitter."  
"And can you tell me why?"  
"I won't have to climb any higher."

## As In Golf

"Are you the groom?" asked the bewildered old gentleman, at a very elaborate wedding.  
"No, sir," was the reply of the embarrassed young man, "I was eliminated in the preliminary try-outs."—*The Pilot.*



## Another Unwritten Law

Judge: "Why did you break that plate-glass shop window?"  
Accused: "That's the window my wife always looks in on pay day."  
Judge: "Not guilty."

## Rebuke

"John, that man next door tries to flirt with me."  
"Well, we can't move just because he isn't handsome."

## Not in the Book

"Pop, if a new man works twice as fast as the old man and three times as fast as the foreman, how much work does he do in one day?"  
"Very little—if he lives till the noon whistle blows."

## On the Rubberneck

"Ladies and gentlemen," said the megaphone man, "on your right you see a monument erected to a noble cause." "And what does it stand for?" asked a tourist. "Because, madam," said the guide, "it would look silly lying down."—*The Trestle Board.*



## Easiest Way

Iowan: "Don't you try to find a way to stop those tornadoes?"  
Nebraskan: "Nope, we just go along with 'em."

## Ambulance, Please

He: Say, I just made an awful blunder! I just told a man that I thought the host was a stingy old guy and he turned out to be the host himself.  
She: Oh, you mean my husband!—*The Far East.*

## Broad Minded

"Nola, will you marry me?"  
"Doug, I must tell you I'm a somnambulist."  
"That's all right—you can go to your church and I'll go to mine."—*The Trestle Board.*

## His Turn Coming

Teddy: "I had a beautiful dream last night."  
Freddy: "Yeh, I know, but I'm taking her out tonight."

## Prejudiced

"Are you in favor of a thirteen month calendar?"  
"Certainly—I've been a landlord two months now."

## Saddest Event of the Month

A doctor advised a sick man to take more exercise and to walk ten miles every night after work and then discovered that the patient was a mailman.—*Royal Arcanum Bulletin.*



# How Are These *for* Ticklers?

## Messy

Binks: "Did they throw rice at you, too?"  
Jinks: "If they did the stuff was cooked."

\* \* \* \*

## That's About All

Jennings: "What can a man do when a woman insults him?"

Hennings: "Wind the clock and go to bed."

\* \* \* \*

## Like French Pastry

He: "Do you like old fashioned Swedish cooking?"

She: "It's all Greek to me."

\* \* \* \*

## His Only Refuge

"I'm glad to see you come to church so often with your wife," said the minister.

"Better not give me too much credit, parson," was the reply:

"it's the one place where my wife keeps her mouth closed and let's some one else do the talking." — *Hardware Dealers' Magazine.*

\* \* \* \*

## Giveaway

"I went to a weekend party that lasted thirty days once."

"So you've been in jail too."

\* \* \* \*

## Hollywood Chat

First Star: "Do you

pick a husband like a car, dearie?"

Second Ditto: "I should say not—I'm very particular when it comes to motors."

\* \* \* \*

## Unimportant

"Have you got comp'ny at your house, Shorty?"

"No, just rel'tives."

\* \* \* \*

"My wife would make a regular umpire."

"How's that?"

"She thinks I'm safe when I'm out."

\* \* \* \*

"You're one of these boys that neck all the time."

"Oh no, I'm still working eight hours a day."

\* \* \* \*

She: "But I'll be a sister to you."

He: "All right—assist me in finding another girl."

\* \* \* \*

## Atmosphere

"That hotel is just like home."

"Yes, they bawl you out for most anything."

\* \* \* \*

## Question

"No, Junior, lightning may strike but thunder is quite harmless."

"Then how could Grandma say she was thunderstruck?"

## Interlude

"Is yoh wife on vacation too, Sambo?"

"Yessah, she fell down las' night an' sprained her ironin' hand."

\* \* \* \*

## Satisfaction

"That hunter hit the right spot," said the leopard, licking his lips and yawning.



\* \* \*

## Well, They're Quite Speedy

"The census man is at the door, Mr. Nuwedd."

"For goodness sake—how did he know the stork arrived last night?"

\* \* \*

## Wedding Stuff

"And when the soloist sang 'O Promise Me'—"

"Yes, what then?"

"A dozen fellows hollered, 'She did!'"

\* \* \*

## Another Good Reason

"But you have plenty of money, dear, why start a charge account?"

"You don't understand, John, with a charge account you can return things without any fuss."

\* \* \* \*

## Sensible Argument

"Sambo, let's open a pool room."

"Ain't no money there—nobody goes to a pool room till they's done spent their cash."

\* \* \* \*

## Tracer Wanted

"John, the cook ran away with the garbage man."

"Well, call up the health department."

\* \* \*

## Premature Request

"Rufus, why don't yoh present yoh wife t' me?"

"Ah ain't tired ob her yit."

\* \* \* \*

## You Said It!

"What do ashes of regret mean?"

"The smoking stand full and the humidor empty."

\* \* \* \*

## Full Information

"What's on the radio, John?"

"A pair of golf hose and a pink kimono."



---

# Radio Vella Cook's Big Opportunity

---

**T**HIS is just a little family chat concerning a Cook who loves to sing and a singer who loves to cook. It is about Vella Cook, radio's favorite contralto—the first vocalist to warble sweet notes to a listening world over Station WCFL. That was back in July, 1926, and Miss Cook has been singing over WCFL ever since. No doubt you have enjoyed her sweet songs many, many times and have seen her picture in radio magazines and radio pages of newspapers. However, here is another charming picture of Miss Cook—one that she says is her favorite.

Having talked with Miss Cook on numerous occasions about her work and having been permitted to read some of the hundreds of lovely letters she receives from appreciative listeners, curiosity prompted us to inquire about her reaction to her work, and how and where she started to sing over the radio. Miss Cook boasts that she is the veteran singer of WCFL—and seniority carries an implication that most women shun. However, Miss Cook is not a bit squeemish about such things. She told her age without us asking.

"I've been singing for twenty-five years," replied Miss Cook to our inquiry regarding the genesis of her work, "most of that time professionally." She started when in her early teens.

"For several years before radio burst upon us, I had been singing at weddings, banquets and other social functions, also at many funerals. I do not recall just how my first radio opportunity came to me, but it was over Station WDAP, the Chicago Board of Trade station on the Drake hotel. That station long ago was superseded by Station WGN. We didn't have a radio, and my sister listened in at a corner drug store, waiting there for me. When I joined her she was still so excited she could hardly talk—it was so wonderful and strange.

"Other radio opportunities followed quickly and I sang over a number of the earlier stations. In those days, too, the audiences were more expressive of their appreciation—or perhaps they wanted to verify their loggings. At any rate I received hundreds and hundreds of the most encouraging letters. They are still coming but not so numerous as a few years ago. Radio is now accepted as a matter of course. Every one of these letters has been carefully filed away. I treasure them as sweet memories. Some of them came to me addressed merely, 'Vella Cook, Radio.'

"One evening in the spring of 1926 after I sang before a Swedish club, Franklin C. E. Lundquist introduced himself and asked that I help him secure talent for a new radio station that the Chicago Federation of Labor was soon to open. I like new adventures, so I consented. We made the rounds of the other radio stations and booked a number of good musical features.

"I'll never forget that opening night. The studio was up in the tower of the Municipal pier, alongside the broadcasting equipment. The night was warm and after three or four hours of work, the announcer closed the station and we all went down to the refreshment stand

on the pier to cool off a bit. Then I induced the operator to go back and reopen the station, saying I would do the announcing. Until the early morning hours we kept our program going—and we got a tremendous response."

Few radio singers put as much feeling into their work or seem to enjoy it as does Miss Cook. She says: "When I'm singing over the radio I can shut my eyes and vision vast fields and isolated homes with the happy family circles gathered round the radio sets. My imagination goes out farther and farther."

But, then, Miss Cook can be pardoned for feeling that way—she was born in Chicago and has never lived out-



Miss Cook's favorite picture

side the big city. Her girlhood home was a quiet spot midway between a police station and a fire house—and Miss Cook still cherishes a high regard for policemen and firemen.

It is with old home songs—the songs of tenderest memories—that Miss Cook has scored her greatest success. Among her most popular numbers are: "Rosary," "Out of the Dusk," "The Old Refrain," "The Old Rugged Cross," "An Evening Prayer," "Indian Love Call," "Silver Threads Among the Gold," and "Sweetest Story Ever Told."

Now, all of you who have read this little chat down to this point, no doubt, are wondering, "Does radio work pay?" Well, Miss Cook says most emphatically yes, especially in a big city. The incidental benefit surpasses the direct remuneration—Miss Cook has more engagements than she can fill, as the result of her radio work.

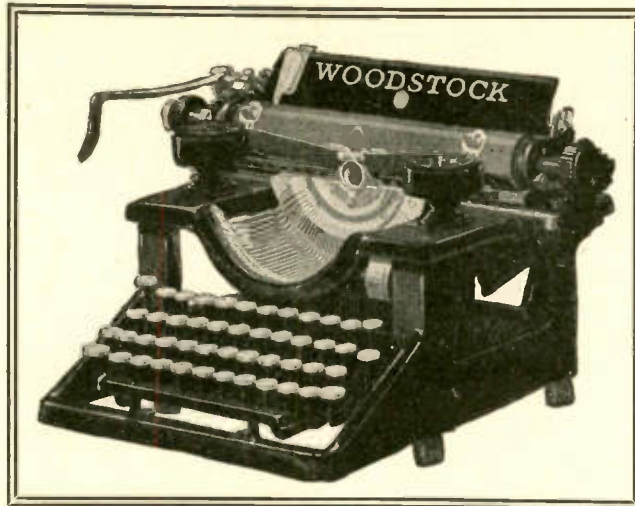

Take It From Any Angle—  
ease of operation, dependability, high  
grade character work—and you'll realize  
the Woodstock is without a peer.



*The Woodstock Electrite, newest  
member of the Woodstock family,  
has all the features of the standard  
Woodstock—plus the advantage of  
electrical operation. Send for book-  
let, which describes both machines.*

*Branches and Distributors Everywhere*

# WOODSTOCK

Woodstock Typewriter Company  
General Sales Office:  
34 East Wacker Drive  
Chicago, Illinois



Woodstock Typewriter Company  
Branch Office:  
35 North Dearborn Street  
Chicago, Illinois

# Course in Radio and Television

## Free to Our Readers

**G**EE! We didn't realize that so many people are interested in the study of radio! Apparently more folks now are wanting to know how to put a radio circuit together than ever before. The response to a recent offer of a free radio course reveals this to be the case. This offer, sponsored by a small group of progressive manufacturers of radio parts, was printed in the last issue of WCFL Radio Magazine. It was also announced briefly over Station WCFL.

We have never seen an offer quite so popular with serious-minded people as is this free radio course. The enterprising prompters are swamped with applications. They have called a halt, or at least have tried to call a halt. The announcement has been taken off the air but it cannot be recalled from the magazine, which has gone to all parts of the country. The applications continue to pour in. Many of our readers are complaining that they have not received the promised lessons. This is due to no fault of the sponsors; it is just the result of an offer being more popular than anticipated. However, something must be done; these earnest applicants must be supplied, and provision must be made to take care of the hundreds of inquiries yet to come.

Here is a real need—and WCFL Radio Magazine is dedicated to the supplying of real needs. It is a magazine with a serious purpose. Consequently WCFL Radio Magazine has made provision to supply radio instruction of the most reliable character to all who want to learn the secrets of this interesting science. The very best obtainable correspondence short course in radio, including television, is now available to all our readers free of cost. This task is undertaken in co-operation with the enterprising radio parts manufacturers whose offer was published in our last issue. We are resolved to help them supply this crying need for reliable instruction in the fundamentals of radio. The course is open to everyone. You do not have to be a subscriber to WCFL Radio Magazine.

The WCFL Free Radio Course is compiled and edited by some of the best known radio authorities. These men know radio and they also know how to present it so that it will be interesting and understandable to people who are busy with many other cares. This is a course for busy people. From time to time interesting discussions will also be offered by specialists in various phases of radio. The presentation of radio fundamentals will be followed by a clear presentation of television—a field in which Station WCFL is leading.

The course is short, intensive and practical—just the information the earnest student desires. The construction of various circuits is explained, also how to locate and remedy most of the ills that beset radio and television receivers. Being short and intensive, the course is confined strictly to radio and television.

The course is divided into short lessons, each neatly printed and profusely illustrated so that it is easily understood. At the conclusion of each lesson is a brief review or summary. When the student finishes his first lesson

and mails in his review of it, the second will be sent to him. He can get the lessons almost daily, if he can complete the work that rapidly, or he can take as much time as desired. Students who are busy with their daily tasks need not be rushed by those having more time for this radio study. There is no limit of time. When the course is completed in satisfactory manner a certificate will be issued.

Only standard parts are mentioned in the various lessons—parts that are obtainable from any reputable retail radio store. The students are advised what parts are needed but are free to buy them where they can procure them to best advantage. Assistance is afforded students to whom ready sources of supplies are not accessible, and it may be that certain parts will be available for free distribution to the more ambitious students.

This course is open to both boys and girls and to the grownups, too. In fact, most of the enrollments received as the result of the previous offer came from adults, although the course was intended primarily for youths. The WCFL Radio Magazine Free Radio Course is intended for all who are interested in radio—youths and grownups, men and women. Some of the keenest students of radio are women, and many women find radio a most interesting hobby.

In order to avail yourself of this splendid free offer it is only necessary to turn to page three and fill in and mail one of the Business Reply Postal Cards printed there. No postage is required. Registrations may also be phoned to WCFL office, Harrison 1182. However, we would much prefer that you use the postal card—there is less chance of error in name and address.

### What the Kiddies Write About

*(Continued from page 31)*

divides her recreation between roller skating and reading, complains that her mother calls her a "book worm." She is only 11. Dorothy might go stronger along the line of Doris and Lorraine, whose mother tells them she knows they are good, because they help her dry the dishes.

Here's how a request by Michael brought Santa Claus to a home in the neighborhood. He wrote: "I am enclosing the name and address of a family who need help. I wish you would ask over the radio for help. They have five children. They all need shoes and clothing and unless someone lends a helping hand their Christmas will be poor. The father is out of work and sick. The mother is not strong enough to work. I know a basket for Christmas and some clothing will be appreciated. They really need help."

This gives one an idea of the sort of kids that make up our Junior Federation. Now that you know them, it is easy to love them and you will want to hear from them often.

You can answer any advertisement in this issue of WCFL Radio Magazine merely by filling in the Business Reply Postal Card on page 3. No stamp is required.



# They Could Hardly Believe Their Own Ears - when I Switched to *Ground Wave Reception*

"IT'S no use trying to listen in tonight," said Bill as I took his hat "Jane and I tried to get reception during dinner but all we got was static. It's usually this way—just the night they broadcast Paul Whiteman's band or some other good program it's spoiled by howls and fading. Why own a radio at all?" he ended up disgustedly.

"Perhaps my set will do a little better." I suggested. I had a surprise in store for him!

He looked doubtful as I turned on the set switch. I had left my old aerial antenna attached on purpose and soon the room was filled with an ear-splitting excuse for music. Manipulation of the dials only served to make it worse or to choke down reception until it was hardly audible. Occasionally it faded out altogether and I could picture the roof aerial swaying helplessly in the strong wind. Then the jumble and howls would start up again until my wife finally shouted above the din. "Turn that thing off—it's terrible!"

Satisfied, I laughed and disconnected the old aerial and ground wires. I then attached the lead-in wires of my new underground antenna, which I had installed just before dinner. "Now listen!" I commanded.

### The Thrilling Test

As though by magic, the sweet high notes of violins, the stirring sobbing of saxophones, the clear pure notes of a clarinet brought Bill to his feet! Jane looked dumbfounded. Even my wife, who had not paid much attention to my preliminary tests, was amazed. "What did you do to it?" she demanded. "I think he bewitched it," Jane accused. The music went on, clear and strong, with only a long moan or slight jumble now and then to remind us of the storm raging outside.

The static was so greatly reduced that we hardly noticed it. The important thing was—we were getting one of the year's best programs with scarcely any trouble on a wild, stormy night.

"You see," I explained later to Bill. "I buried my new underground aerial about two feet below the ground, where wind and storms can't affect it so easily. It has certainly been proved tonight that radio waves are just as strong in the ground as they are in the air. They call this thing 'Subwave-Aerial' and it's insulated some way to keep out interference and noise. Just like these expensive modern receivers are. It's combined with a scientific ground so I'm sure now that I have the correct ground connection. And all this isn't costing me any more than my old aerial antenna that I've nearly broken my neck repairing after wind storms like this. And last but not least," I finished triumphantly. "I

never need to touch it again. It's guaranteed for 25 years."

Hardly necessary to say that Bill went home with the name and address of the Subwave-Aerial manufacturers in his pocket.

### Test It Yourself—FREE!

The above story illustrates the results for which the designers of Subwave-Aerial struggled for months. At last, enthusiastic reports such as this from Radio Experts reproduced here, proved that they had succeeded. Now you have a chance to prove the merits of this great new radio development for yourself. Try, if possible, to pick a night when static is bad and make the thrilling test. It's fun! And if you are not more than pleased with Subwave-Aerial, the test won't cost you a cent. We feel safe in saying, however, that once you've heard the amazing difference in reception and realize the wonderful convenience of this modern combined antenna and ground, you'll wonder how you ever put up with the old-fashioned, dangerous, inefficient methods. Be sure to send at once for all the interesting details on the development of Subwave-Aerial. It's the newest, most thrilling thing in the romantic world of radio! Use the coupon below. Fill it in and mail it NOW!

## UNDERGROUND AERIAL PRODUCTS

Suite 618, St. Clair Building, Dept. 977-B.W., St. Clair & Erie Sts., Chicago, Ill.



Underground Aerial Products, Suite 618, St. Clair Bldg., Dept. 977-B.W., St. Clair & Erie Sts., Chicago, Ill.

Rush illustrated literature on the new Subwave-Aerial and details of your Free Test Offer.

Name.....  
 Address.....  
 City..... State.....

**Subwave-Aerial Gets DX Installed Fifty Feet From 60,000 Volt Power Line**

Gentlemen:  
 On January 27, 1929, Mr. Frank Smith and I drove out near the Sanitary District power plant in a Ford Sedan. We stopped 50 feet from the plant's 60,000-volt transmission line and dug a small hole, into which we dropped the Subwave-Aerial. We left the two sets we brought with us in the sedan, attaching the lead-in wires of the Subwave-Aerial first to one, then the other, a 5-tube Freshman and a single dial Atwater Kent, Model 35. We used the Ford battery. At 15 minutes to six we got WCCO, St. Paul, Minn. It came in loud and clear at 27 on the dial. There was not the slightest interference from the 60,000 volt power transmission line. We got Toronto, first on one set and then the other. We plainly heard the program, which was being sponsored by a Spartan Radio dealer. It was impossible to get reception at all with an overhead aerial under the same conditions.

Yours truly,  
 HARRY R. JACKSON,  
 F. BENNETT SMITH.

# GOLD SEAL and what a tube!



TRADE MARK

They give you the clearest, truest reception that radio science has been able to produce. Their sweet golden tone is preferred by sound experts who know perfect reproduction.

*Sold by dealers in good tubes, everywhere*

**GOLD SEAL ELECTRICAL COMPANY, Inc.**

250 Park Ave., New York

*Also manufacturers of Gold Seal Electrical Appliances*

