

Interior view of latest RCA
VICTOR 1-K.W. High Fidelity
Broadcast Transmitter insulated
with ISOLANTITE

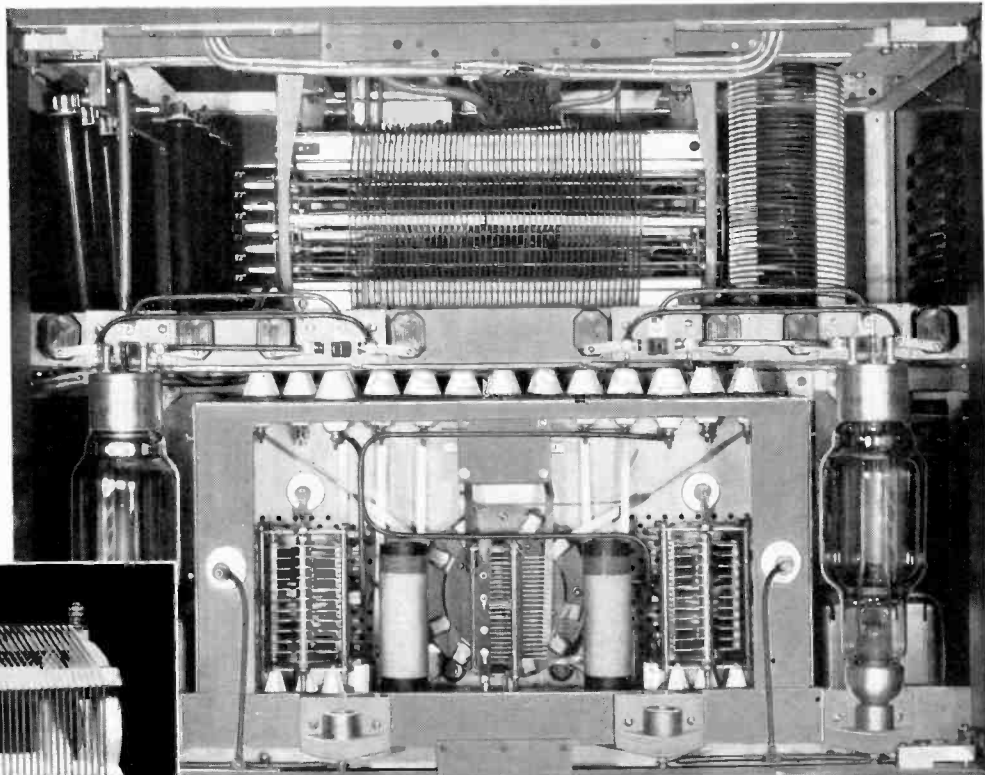

Typical power stage coil on
ISOLANTITE supports

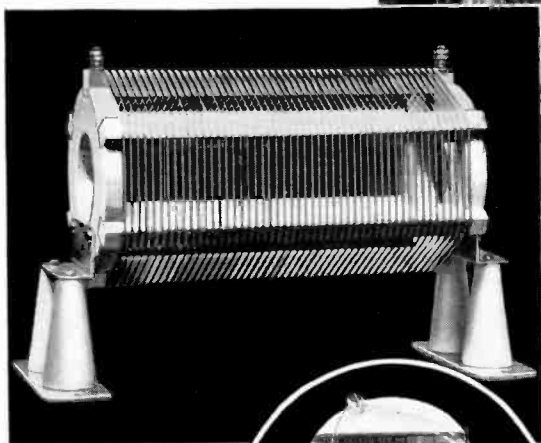

Precision Crystal
Holder of ISOLAN-
TITE, by Premier
Crystal Laboratories

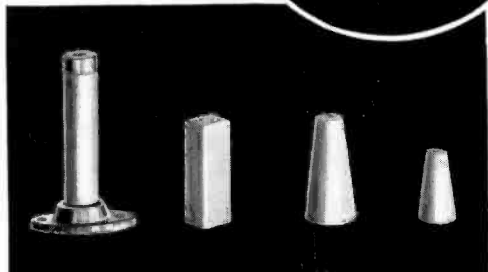
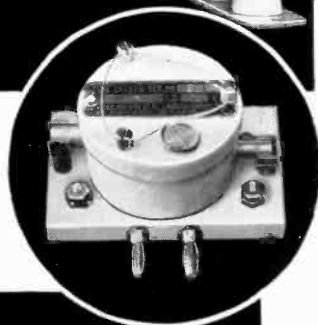

Standard ISOLANTITE Stand-off insulators
used in transmitter construction

HIGH FIDELITY
*is only possible with circuit
and frequency stability!*

ISOLANTITE precision Crystal Holders, Tuning Condenser insulation, sockets, bushings, Stand-off Insulators and Coil Supports . . . are contributing extensively to modern *high-fidelity* broadcasting.

Hold your frequency and circuit stability by using ISOLANTITE insulation — produced to meet the most exacting precision requirements. A copy of our Bulletin 100-F, describing our product in full detail, will be sent upon request.

Isolantite Inc.

FACTORY at BELLEVILLE *New Jersey*
New York Sales Office 233 Broadway



Introduces New Type of HOOK UP WIRE

INSULATION RESISTANCE
UNDER
EXTREME HUMID CONDITIONS

at
74 deg F. 90% relative humidity
FOR 100 HOURS
1800 MEGOHMS
IN MERCURY

MOISTURE ABSORPTION
0.34% BY WEIGHT

INSULATION RESISTANCE
AT HIGH
OPERATING TEMPERATURE

120 deg. F. 38% relative humidity
FOR 100 HOURS
2100 MEGOHMS
IN MERCURY

VOLTAGE BREAK-DOWN PER FOOT
IN EXCESS OF 3500 VOLTS A.C.

The above results obtained on one foot lengths in mercury

You need the best insulation obtainable on set hookup wire. This grows more apparent especially since great interest is manifested in High Fidelity, Auto Radio, and All Wave Receivers.

LENZITE is the name of this new hook-up wire. The insulation consists of *cellulose acetate treated textile* plus *cotton* braids thoroughly saturated in *moisture resisting* compounds. This wire can also be furnished saturated in slow burning high di-electric lacquer.

Auto radio and *all wave* receivers both need a push-back wire having textile insulations of extremely high dielectric characteristics including low moisture absorption.

LENZITE is especially adaptable for use in auto radio manufacture because auto radio is subject to all kinds of extreme weather conditions.

LENZITE is most suitable for use in all wave radios because it is non-moisture absorbent, thus preventing shifting of alignment and distortion.

Production managers will like LENZITE insulation because it pushes back freely and stays in position. There is no buckling or fraying of the braid that will interfere with production operation.

LENZITE can also be used in all standard home radio receivers and receivers subject to extreme humid conditions as in the south, salt air conditions on the coasts and in receivers manufactured for export.

PARTIAL LIST OF LENZ PRODUCTS:

Push-back wire	Battery and speaker extension cable.
Indoor aerial	Flexible rubber covered lead-in wire
Auto radio cable	Ground wire
Microphone cable	Shielded low capacity cable
Short wave lead-in	Elevator annunciator cables
Shielded wires and cables	Organ cables
Speaker and head set cords	Flameproof jumper wire
	Specially constructed shielded cables

We have served the telephone and communications industries since 1904 and have served the leading radio manufacturers for the past ten years. We are now in a position to serve all industries including telephone, broadcasting and communications, automotive, electrical, radio, public address, sound picture, and other industries using cords, wires, and cables. Send us your blue prints and let us submit samples and quote on your requirements. Our engineers will be glad to cooperate with you and discuss your problems.

LENZ ELECTRIC MANUFACTURING CO.

1751 North Western Avenue
CHICAGO, ILLINOIS
ESTABLISHED 1904

Telephone: Armitage 4454 Cable Address: Lenzco Chicago

Lenz Electric Manufacturing Co.

1751 No. Western Ave., Chicago

Gentlemen: Please send me 25-foot sample of number 20 solid LENZITE wax impregnated radio receiver hook-up wire.

Send price list on hook-up wire.

Please have your representative call.

Name Title.....

Company

Address

Marked Panel Boards

by
Several

Processes . . .

PANEL boards with simple or elaborate markings are produced from Formica in a variety of ways. They are printed in gold or silver colors by the Verichrome process; they are marked by silk screening; they are engraved on engraving machines, and they are

stamped with a die and a white filler paper.

The panel illustrated consists of black markings on a white field—it is very easily legible and novel in appearance for an insulating panel.

If you have a problem of producing panel boards for instruments put it up to Formica.

THE FORMICA INSULATION COMPANY • 4636 SPRING GROVE AVE. • CINCINNATI, O.

FORMICA

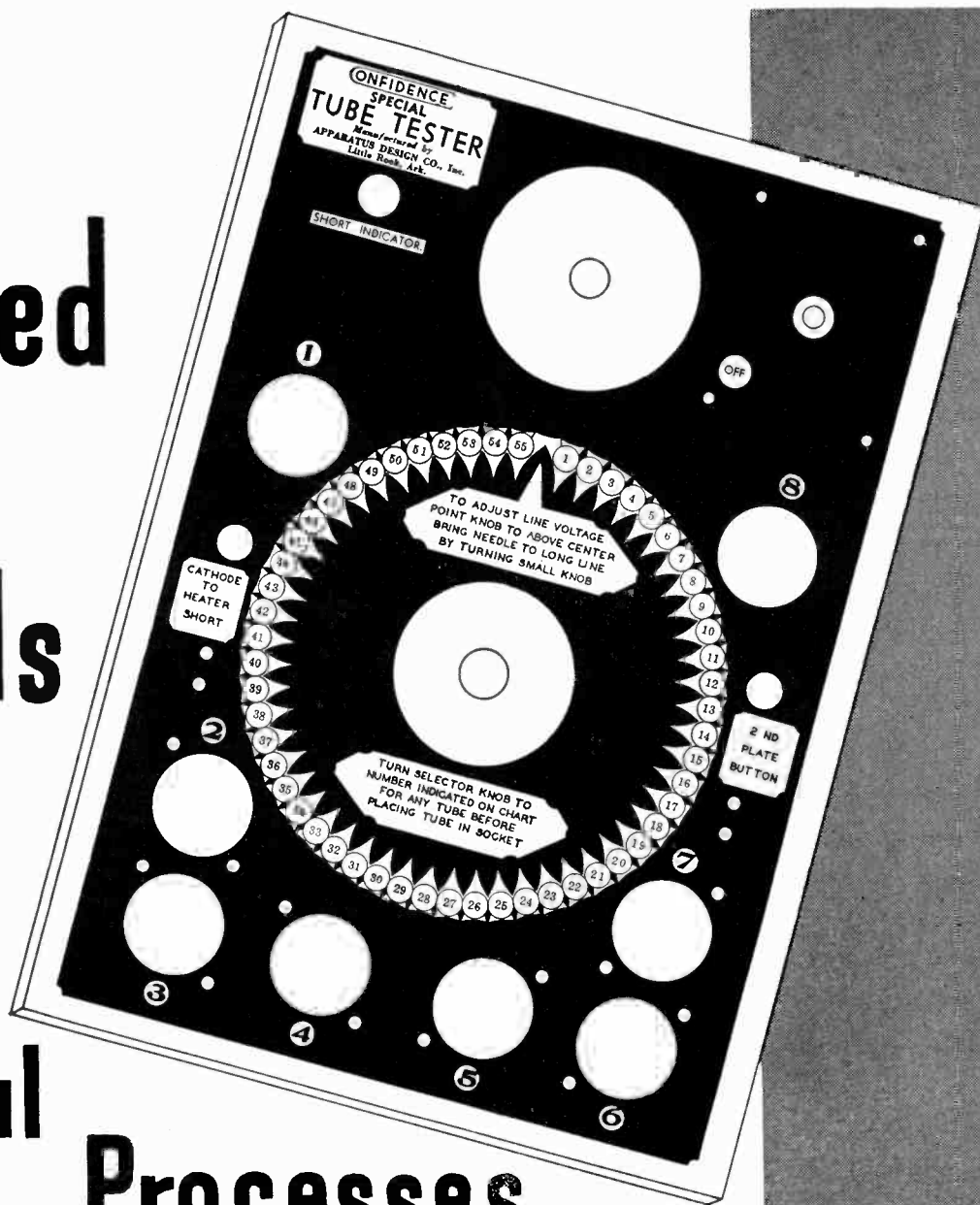

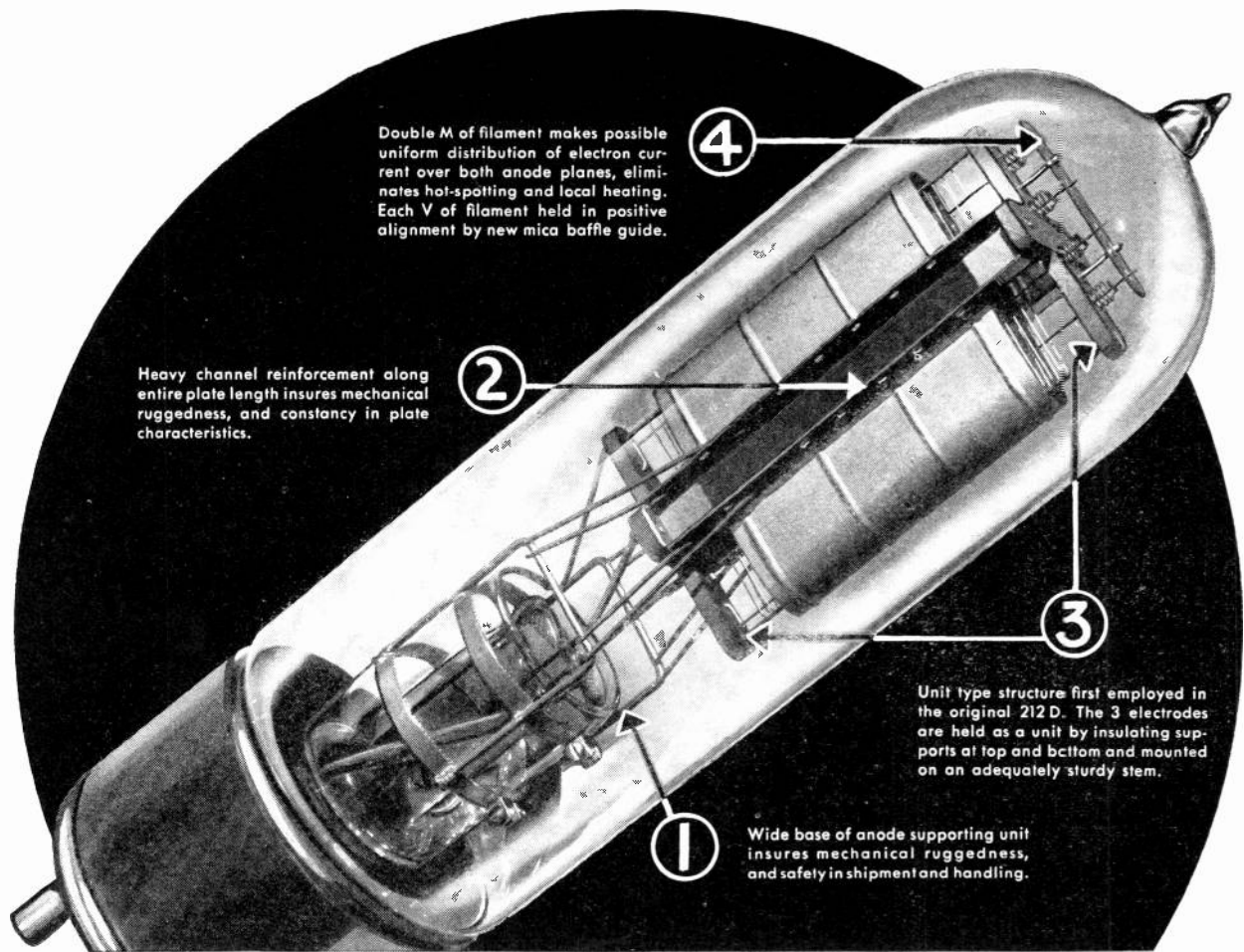

Double M of filament makes possible uniform distribution of electron current over both anode planes, eliminates hot-spotting and local heating. Each V of filament held in positive alignment by new mica baffle guide.

Heavy channel reinforcement along entire plate length insures mechanical ruggedness, and constancy in plate characteristics.

Unit type structure first employed in the original 212D. The 3 electrodes are held as a unit by insulating supports at top and bottom and mounted on an adequately sturdy stem.

Wide base of anode supporting unit insures mechanical ruggedness, and safety in shipment and handling.

Cut operating costs

...with **NEW 212E Tube!**

Characteristics of 212E Tube

Filament Voltage.....	14
Normal Filament Current Amperes.....	6
Average characteristics with a plate voltage of 1500 volts and a grid bias of -60 volts:	
Average Amplification Factor.....	16
Average Plate Resistance, ohms.....	1900
Average Trans-Conductance, micromhos.....	8500
Plate Current, Milliamperes.....	147
Maximum Operating Plate Voltage.....	2000
Continuous Plate Dissipation, watts.....	250
Maximum Plate Dissipation, watts.....	275
Maximum Plate Current, milliamperes.....	300
Approximate Direct Interelectrode Capacities:	
Plate to Grid, Mmf.....	18.8
Plate to Filament, Mmf.....	8.6
Grid to Filament, Mmf.....	14.9
Maximum Overall Length.....	13 ⁵ / ₈ "
Diameter.....	3 ⁵ / ₈ "

For full details, write Graybar Electric Co., Graybar Building, New York — or telephone Graybar's nearest branch.

The Western Electric 212E general purpose tube materially lowers operating costs for all type 212 sockets. It may be used as an audio-frequency amplifier, radio-frequency amplifier or modulator.

The 212E takes its place alongside the Western Electric 279A, 270A and 251A thoriated tungsten filament, high power transmitting tubes. The major improvements in the 212E — as compared with the 212D — are (a) Greater uniformity in electrical characteristics throughout life; (b) Increased electron emission — permitting 100% modulation with less distortion; (c) Greater plate dissipation capacity giving increased safety from trouble during overloads; (d) Much longer life in all types of service lowering materially tube hour cost.

Matching the original 212D in characteristics and dimensions from the standpoint of interchangeability, the 212E offers many advantages, assures highest quality performance through an extremely long life.

Western Electric

RADIO TELEPHONE BROADCASTING EQUIPMENT

Distributed by **GRAYBAR Electric Company**

In Canada, Northern Electric Co., Ltd.



PERFORMANCE

PRESTIGE

PROFITS

Performance, Prestige and Profits are built upon Parts

"Trifles make perfection and perfection is no trifle." A part may be "only a detail"—yet a completely assembled radio (or any other device) will be no better than the *parts* from which it is constructed.

The work of Mallory-Yaxley engineers in developing "parts that perfect the whole" is known, and favorably regarded, throughout radio, electrical, metallurgical and industrial fields.

P. R. MALLORY & CO.

INCORPORATED

INDIANAPOLIS, INDIANA

CABLE ADDRESS: PELMALLO

YAXLEY MANUFACTURING CO.

INCORPORATED

Division of P. R. MALLORY & CO., Inc.



in RADIO, ELECTRICAL,
AUTOMOTIVE AND
INDUSTRIAL FIELD

MALLORY YAXLEY PRODUCTS

Dry Electrolytic
Condensers (AC-DC)
Radio
Motor Start

Volume Controls

Rheostats

Potentiometers

Variable Resistors

Circuit Selector Switches

Tap Switches

Push Button Switches

Jack Switches

Junior Jack Switches

Midget Jacks

Plugs

Cable Connector
Devices

Dial and Pilot Lights

Dial Plates

Relays

MALLORY YAXLEY PRODUCTS

Cable Markers

Radio Convenience
Outlets

Automobile Radio "B"
Eliminators

Automobile Battery
Chargers

Rectifiers for Chargers,
"A" Powers, etc.

Electrical Contacts

Tungsten

Silver

Platinum

Welding Electrodes

Elkonite

Elkaloy

Sheet Tungsten

Molybdenum

Hard Facing Metal

MALLORY
ELKON

YAXLEY

electronics

O. H. CALDWELL
Editor
KEITH HENNEY
Associate Editor

McGRAW-HILL PUBLISHING COMPANY, INC.

New York, July, 1934



radio
sound
pictures
telephony
broadcasting
telegraphy
counting
grading
carrier
systems
beam
transmission
photo
cells
facsimile
electric
recording
amplifiers
phonographs
measurements
receivers
therapeutics
traffic
control
musical
instruments
machine
control
television
metering
analysis
aviation
metallurgy
beacons
compasses
automatic
processing
crime
detection
geophysics

Synchronized broadcasting

ON July first the new Federal Communications Commission took over control of radio. It is to be hoped that the new regulating authority will be more receptive to new ideas and technical developments than was the old Federal Radio Commission.

Take the matter of synchronizing broadcast stations for common-frequency operation, at which the old F.R.C. repeatedly balked. Today equipment is all ready, complete experiments have been made, and several successful individual installations are in use. Synchronizing is now a demonstrated fact.

SYNCHRONIZING, indeed, seems the only ultimate avenue for solution of a whole group of problems that are facing broadcasting. Here are some of the needs for which synchronizing supplies prompt answers:

Wider channels (15 to 20 kc.) for high-fidelity broadcasting
Efficient use of broadcast channels
Channels to meet demands of Canada, Mexico and Cuba
Common-frequency broadcasting by chain stations with high fidelity
Positions in the spectrum for stations requiring good local coverage
Higher wattage on channels, but distributed among synchronized transmitters

In fact, all the present "headaches" of broadcasting seem to find their solution in this panacea of synchronizing, intelligently applied.

WE hope the new Commission will give the subject of synchronizing on the broadcast channels careful and sympathetic study. Also that it may find a sensible interpretation of the iniquitous Davis Amendment applied to synchronized transmitters, which will encourage rather than restrict good radio service.

REVISE TRANSMITTER

Radio-Transmitter Section, NEMA, discusses commercial problems, preparatory to formulating Code under NRA

BARELY six months old, organization machinery has now been set up for the improvement and standardization of commercial practices in the field of radio transmitters, transmitting tubes, public-address and music distribution, and commercial radio receivers and direction-finders.

This is the new "Radio Transmitting, etc." Section of the National Electrical Manufacturing Association, formed the first of this year, and now holding monthly meetings to discuss trade practices in the radio-transmitter and sound fields, as well as to draft the Radio Transmitting, etc., Supplementary Code. This Supplementary Code is for use with the NEMA Electrical Code under NRA, which was approved by the President last summer.

The full name of the new section,—highly definitive, though seldom used,—is as follows "The Radio Transmitting Apparatus, Public Address and Music Distribution Apparatus, Radio Transmitter Tubes, Commercial Radio Receivers, and Direction-Finder Section of the National Electrical Manufacturers Association."

The chairman of the section is



G. W. Henyan, Chairman

G. W. Henyan, of the General Electric Company, Schenectady, N. Y., and the secretary is H. E. Young, general commercial engineer, Western Electric Company, 195 Broadway, New York City.

Principal committees now at work, and their chairmen, are:

Officers and committees

Advisory Committee, H. J. Hoffman, Westinghouse Lamp Company, Bloomfield, N. J.; Technical Committee, E. L. Nelson, Bell Telephone Laboratories, 180 Varick Street, New York City; Membership Committee, A. H. Castor, RCA-Radiotron Company, Camden, N. J.; Statistical Committee, C. M. Hobart, Westinghouse Electric & Manufacturing Company, Chicopee Falls, Mass.

The Supplementary Code for radio transmitters, etc., has now been drafted, and will be submitted to the section membership at a meeting to be held at the Westchester Country Club, Rye, N. Y., July 13 and 14. Some fifteen manufacturing companies are already members of the new Section, although a total of nearly a hundred firms now producing apparatus in this field, are believed to be eligible.

As soon as the Section's Supplementary Code is approved, and a Price Call goes out to all concerns operating in the field, it will be mandatory for all firms doing such business, whether members or not, to submit prices to the Section's Supervisory Agency, F. B. Gleason, 195 Broadway, New York. From then on, non-member firms will also be assessed for their pro-rata expense of the cost of administering the Code and price reports, under the usual NRA practice. Having the same responsibilities and expenses as member companies, it is expected that non-member firms will promptly apply for membership in order to participate in the formulation of the rules under which the radio-transmitting, etc., industry groups are to operate.

Statistics are now being collected

to show the billings and sales of apparatus of the classes covered by the Section, both prior to the end of 1933, and quarterly since. These figures will be grouped by dollars of radio transmitters, transmitter tubes, public-address and sound apparatus, and commercial receiving sets. Already the call for these figures is in preparation by the statistical committee, and it is expected that the figures will be available by the end of August.

But it is in the standardization and simplification of types of apparatus, business practices, prices, and technical specifications that the leaders of the new NEMA Section feel they can accomplish most service to the industry.

For example, in place of a wide range of miscellaneous guarantees on transmitting tubes, running from 50 hours to 1500 hours, thought is now crystallizing on 1000 hours as the common guarantee of all manufacturers. Ordinarily tubes show up any mechanical fault within 50 hours, and after having passed that point, start in on their normal life run, which the new NEMA agreement will set as 1000 hours. Where tubes fail after 50 hours of life, but before



H. E. Young, Secretary

SALES PRACTICES

Outline of proposals to standardize transmitter-apparatus definitions, terms, guarantees, discounts, collections, etc.

the guaranteed 1000 hours of service, it is proposed that adjustment be limited to the amount that bears the same proportion to the price, as the difference between hours of life at failure and the guaranteed life, bears to the guaranteed life. No guarantee, it is recommended, shall be made covering a period of more than two years from date of manufacturer's shipment. Periods of service are limited to one year on all apparatus.

Excessive claims in advertising or sales literature are to be eliminated by the restriction that all claims must be met by performance within actual use. Claims concerning ratings must be met within 5 per cent.

Uniform selling conditions with respect to any product or line of products may be established by the Supervisory Agency, if 75 per cent of the current production is involved, and if in the Supervisor's judgment the conditions created are fair and do not give unfair competitive advantages to the group of manufacturers proposing the plan. The schedule for such a plan of uniform selling, may establish a definite classification of customers, discount schedules to each class, terms of payment and other conditions of sale.

Terms of sale of transmitting apparatus and tubes shall not be more



H. J. Hoffman, Advisory Committee



A. H. Castor, Membership

liberal than 30 days net, and the discount for payment within this 30-day period must not exceed two per cent.

Public address and music distribution apparatus may be sold under terms of deferred payment for one year, if sale exceeds \$500, and for two years if sale exceeds \$10,000. All other apparatus comprehended in the scope of the Section is subject to deferred payments, only if amount of sale exceeds \$10,000, and then for no greater period than two years. In each of the above cases an initial payment of 25 per cent is required, the balance to be paid in equal monthly amounts, with interest on unpaid balance at not less than 6 per cent per year.

Free trials to any customer, in the case of new models or designs, are limited to one "unit" of apparatus, or one "set" in the case of tubes, and then only for the purpose of obtaining operating or service data on new equipment. Such loaned apparatus must remain under the supervision of the manufacturer or his agent.

In the case of standard apparatus and tubes, for the purpose of sales promotion, not over two sets of ap-

paratus or tubes may be loaned, and in no case for periods exceeding five days.

In the matter of retail price maintenance, it is proposed to place on the manufacturer concerned, the responsibility of seeing that his distributors or other sales agencies sell in accordance with NRA provisions, although such distributors themselves will not be members of the Code group. In the case of a distributor failing to maintain prices, it is proposed that the manufacturer discontinue selling to such distributor.

Rules concerning lump-sum bidding will require that unit prices of individual items be shown, the total sum of the unit prices to be the lump-sum price. It is also proposed to eliminate clauses that are obscure.

In addition to the commercial and trade practices outlined in the foregoing, an increasing proportion of the Section's attention is now being given to technical standardization and specifications, clarifying the many points which still lack general agreement, and which demand clear definitions as to ratings, performance, accepted practice, etc. This expanding technical activity of the new NEMA radio-transmitting Section will be discussed in a later article.



C. M. Hobart, Statistics

The prospects of high-fidelity transmission

plain talk on the broadcast system by an engineer
thoroughly familiar with the subject

TALK about high-fidelity transmission of broadcast programs is not new—it has been going on for several years. The nature of this conversation has largely concerned itself with laying the blame for the low fidelity now prevailing—the broadcasters stating the fault belonged, almost exclusively, with the receiving set manufacturers and the latter stating that the broadcast picture was pretty black, except in spots.

It is a fact that both transmitter and receiver are intimately concerned in the high-fidelity system—and again this is not new. Up to the present, however, this knowledge has not been taken very seriously, the broadcasters and receiver people confining themselves to statements of mutual recrimination.

Recent interest in high fidelity must focus attention on the weak spots—and let the chips fall where they may. In this present opus the chips may seem to fall mostly on the broadcast station and its operating personnel.

It must not be assumed that all transmitters are poor, or poorly operated, or, on the other hand, that the majority of listeners now get the service rendered by a few of the metropolitan stations. Some of the broadcasters have made extraordinary efforts to render high-fidelity service, even when there are no receivers to pick it up—but the number of these altruistic stations is few indeed. And it must be said, in all fairness to station designers, that even a station good out to 10,000 cycles and capable of keeping its modulation out of other stations' channels is not so good if the commercial department demands 150 per cent modulation to prove coverage.

It is now possible to buy station equipment capable of transmitting a band from 30 to 10,000 cycles (in fact, no one will buy anything else), and capable of correct modulation to a high percentage—in fact, capable of ren-

dering high-fidelity transmission if it can get any way to pay for the necessary programs and lines.

The ability to transmit a uniform band from 30 to 8,000 cycles, more or less, is not the sole criterion of high fidelity—there are other requirements, even more severe. For example, after uniform audio response, it is necessary that the waveform distortion be very low. Spurious audio harmonics are introduced by waveform distortion which alter the original character of the sounds. Various specifications have been adopted by engineers for maximum tolerable distortion. What is always sought in high-fidelity transmission systems is a straight-line relation between energy flux density in the sound wave picked up by the microphone, and the antenna current. The FCC specification is a maximum of 10 per cent when all the harmonic amplitudes are added arithmetically; but this only applies to the transmitter proper.

Furthermore, extraneous noises and interference impair the quality of the original program. For this reason residual modulation, or carrier ripple, must be reduced to the level where it is inaudible when a loud program signal is removed. That means at least 50 decibels below program level. Line noise, switching clicks, etc., should be considered as residual modulation. As viewed from the position of the listener, similar consideration should be made for other noises received simultaneously with the desired signal, such as heterodyne interference, interchannel interference, cross-talk, and local noise level.

In the attainment (or loss) of high-fidelity transmission, the responsibilities are divided between the supplier of apparatus, the supplier of telephone line services, the licensing authority and the broadcaster himself.

Competition among leading manufacturers, as well as

THE PICTURE FROM THE BROADCASTER'S VIEWPOINT

THE DARK SIDE—

- High-quality monitoring in use in stations is rare
- Practically all broadcast stations tend to over-modulate
- Most stations properly equipped are not properly operated
- Too few of the transmitting stations are "quality conscious"
- Performance and condition of equipment unknown to most stations
- Majority of stations studios are unsatisfactory for high quality
- Lack of telephone lines capable of wide-range chain transmission
- Heterodynes and cross talk limit night high-fidelity service areas

THE BRIGHT SIDE—

- High-fidelity, wide-range electrical transcriptions are now available
- Some stations observe the operating technique for high-fidelity service
- Awakening interest in higher fidelity by some stations (WTMJ, for example)

the exacting demands of a few important purchasers of broadcasting apparatus, has resulted in the achievement of a high degree of technical excellence in the design and performance of radio and audio equipment. Transmitters of all powers are available which feature complete modulation, 30 to 10,000 cycle response within 2 db., low audio distortion, and residual modulation better than 50 to 60 db. below normal program level. Noiseless audio switching, high-fidelity monitoring equipment, improved microphones, improved studio designs, improved antennas which increase primary service area for a given power as well as reduce fading, are other contributions to the cause of high-fidelity transmission.

Necessary technical improvements

Improvements still needed include modulation monitoring devices which will permit the operator to continuously observe the actual magnitude of modulation peaks so that he can eliminate the present-day evil of over-modulation; or a device which automatically limits modulation to, say, 100 per cent if that is the transmitter capacity; improvement in syllabic modulation characteristics; further reductions of audio distortion, especially at the lower and higher ends of the modulation range; further reduction in ripple-level; reduction or elimination of spurious emissions which produce inter-channel interference; a more general application of high-resistance antennas so that the antenna circuit does not limit the higher modulation frequencies; more complete instructions for the operation and maintenance of commercial apparatus, emphasizing the caution required in operation to obtain high-fidelity performance; the inclusion of audio oscillators, oscillographs, volume indicators, modulation analysers, etc., as a permanent part of each installation so that all the essential tests for correct performance can be made periodically as a routine part of station and studio operation, thus assuring optimum performance of the equipment over long periods; noiseless positive-contact tube-sockets for audio apparatus; non-microphonic tubes. These are some of the items that bear directly upon high-quality transmission. Some of these needs are already provided for by newly announced devices.

Apparently the apparatus used in transmission (or obtainable) is suitable for high-fidelity service. Regardless of the perfection of studio and station apparatus, the program can be no better than can be transmitted by the lines connecting them. The usual studio to station service provides 5,000-cycle lines. Eight-thousand-cycle lines have been obtained by some of the leading stations by paying higher rental charges. Stations having their transmitters adjoining their studios have an advantage here by the elimination of the line

Links in the broadcast system where fidelity may be lost

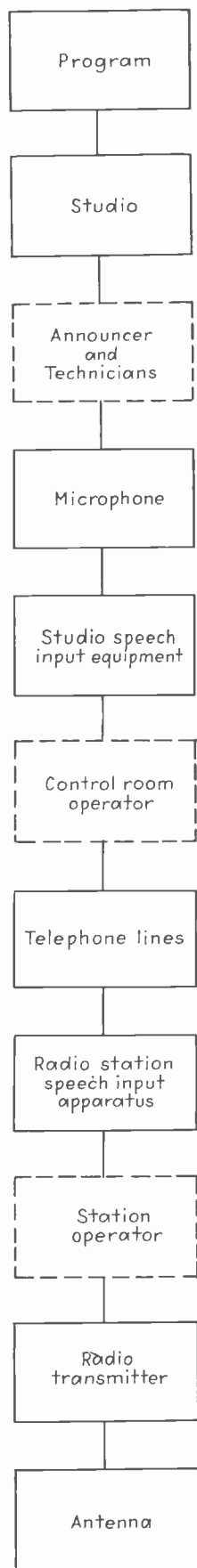

limitations. The long lines used for chain broadcasting are seldom better than 5,000-cycles on the high end and 80 to 100 cycles on the low. Many circuits will not deliver frequencies over 4,000. Here again better lines can be constructed, but line charges quickly become prohibitive. Even with their limitations, present line characteristics are better than the receivers.

Where the government comes in

The federal licensing authority can do much to promote a general improvement in fidelity of transmission by imposing minimum technical standards of performance. At the present time, audio harmonics and percentage of modulation are the only items bearing upon fidelity that are specifically regulated, and, from observed station performances in all parts of the country, even these are not enforced. Because they receive a free public franchise to broadcast, stations should be required to adhere to the strictest standards of technical performance. Stations should be obliged to submit to the FCC a complete set of performance data for their equipment with each new license renewal application. This report should include a carefully specified, complete collection of data, capable of accurately revealing the condition and capabilities of all the equipment used in this public service.

Radio transmission equipment requires periodic readjustment to maintain optimum performance, just as automobile brakes do. A good characteristic at the time of installation is no assurance of continuing correct operation. Without such regulation, shameful service will continue to come from dozens of inferior stations.

So far as the present radio inspection service is concerned, it cites only frequency deviations outside the 50-cycle limits, inspects the power amplifier input power or the antenna input power as the case may be, and sees that the station logs are kept. Outside this, the broadcaster has all the latitude he can desire. If high-fidelity broadcast service is to come, new regulations and improved policing (by men who know something about broadcasting equipment) are essential.

Limitations set by inter-channel interference

The licensing authority has, since its existence, made a conscientious effort to reach a satisfactory compromise in matters of heterodyne interference and cross-talk. Unfortunately the field was too well set before they took charge of these matters so that full advantage of the theory of allocations was not realized. Noise-free high-fidelity reception on regional and local, as well as many cleared channels would be confined to a relatively small area in the vicinity of the broadcasting

station. However, these small areas, being mostly urban districts, include a very large number of listeners. Class B and Class C service areas, which prevail over large areas of this country, cannot hope to get much improvement in fidelity, and may even suffer worse reception from cross-talk when 10,000-cycle modulation becomes the rule. There are many who class this as a major difficulty and would limit modulation to 5,000 cycles so long as 10,000-cycle channel separation is maintained. The licensing authority is definitely looking toward high-fidelity transmission in the setting out of the new high-frequency channels where 20-kc. separation and 10,000-cycle modulation range are specified.

With improved station operation, the annoying spasmodic interchannel interference may gradually disappear. Many hear it now and believe it to be rumbling static, or sometimes power-line arcing, while in reality it may be a station as much as 30 or 40 kc. off that is producing the interference by overmodulating, or by improper transmitter adjustment. The broadcasters themselves may learn to watch this to their mutual advantage. It would be possible for the government monitoring stations to police this problem also.

And what of the station personnel

After saying all this, though, it must finally be admitted that the fate of high-fidelity transmission is principally in the hands of the broadcaster. He can obtain equipment for his every need in this direction. He can have it and still not provide high-fidelity service. Perhaps a majority of the stations in this country already have equipment more or less capable of high-fidelity performance. To give such service, the equipment must be maintained in first-class condition, with frequent tests of its operating characteristics. Then it must be skillfully operated at all times. Operators with "wooden ears" should be replaced with ones who have some ability to judge the technical excellence of the transmitted program, and these men should be provided with the best possible monitoring equipment, both visual and aural, to assist them in the proper control of the equipment during operation. Then, too, the operators should be required

to actually listen to programs and to continually watch the operation, at station and studios. (It is currently reported that one of the large stations is to have audiometric tests made regularly of its monitoring engineers' ears!)

It is here, in the personnel of broadcasting stations, that one finds the greatest weakness in the system of men and apparatus required to give high-fidelity service. For every station engineer or operator who has ideals or understanding of what radio service should be, there are a dozen who have none. Since the station owners are very seldom technical men, they cannot check up on those who are supposed to guide their technical destiny. The only thing they can say is that their staff keeps the station on the air. At least three-quarters of the exist-

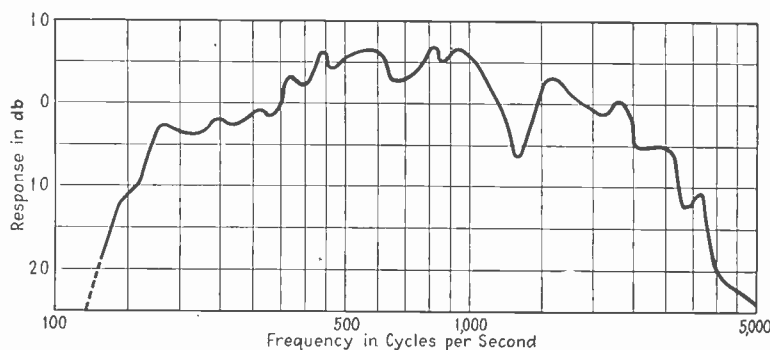

Typical response characteristic of a modern "inexpensive" receiver. Effort toward high-fidelity on the part of broadcasters is of no avail unless receivers are improved.

ing stations are manned by incapable engineers and operators, judged by the standards of personnel required for high-fidelity transmission.

Operators as a class are great sitters and smokers. If the government didn't require them to keep a log many of them wouldn't do anything while on watch. They must be trained to understand

that they have important duties in connection with high-fidelity service.

Those leading broadcasters who make an effort to provide high-fidelity service make frequent tests of their entire equipment, including audio characteristics, distortion, line-noise, carrier ripple, amplifier efficiencies, etc. They repair noisy gain controls, clean noisy tube sockets, and eliminate especially microphonic tubes. They will not permit ordinary Class A amplifiers and modulators to draw grid currents, or tolerate a condition where the antenna current drops during modulation, or permit the antenna current to jump 25% with every word of modulation.

Broadcasters are now enjoying a refreshing boom in business. It is not too much to hope that this prosperity may soon be reflected in radical improvements in the direction of high-fidelity transmission.

It is certain that autumn will see wide-band receivers on the market and the slow process of educating the listener back to his ancient and correct ideas of music will begin.

HIGH FIDELITY—

A WEAPON AGAINST STAGNATION IN THE BROADCAST INDUSTRY

Radio broadcasting cannot stand still, for a static art is drifting backwards in relation to its competitors and cannot hold the interest and approval of the public. Broadcasting has done well in many respects, but it cannot afford to rest on its laurels. It will be alike to the benefit of the listeners and the radio industry to carry forward a consistent and active campaign for the improvement of fidelity of the entire broadcasting system along thoughtful lines.

—DR. ALFRED N. GOLDSMITH

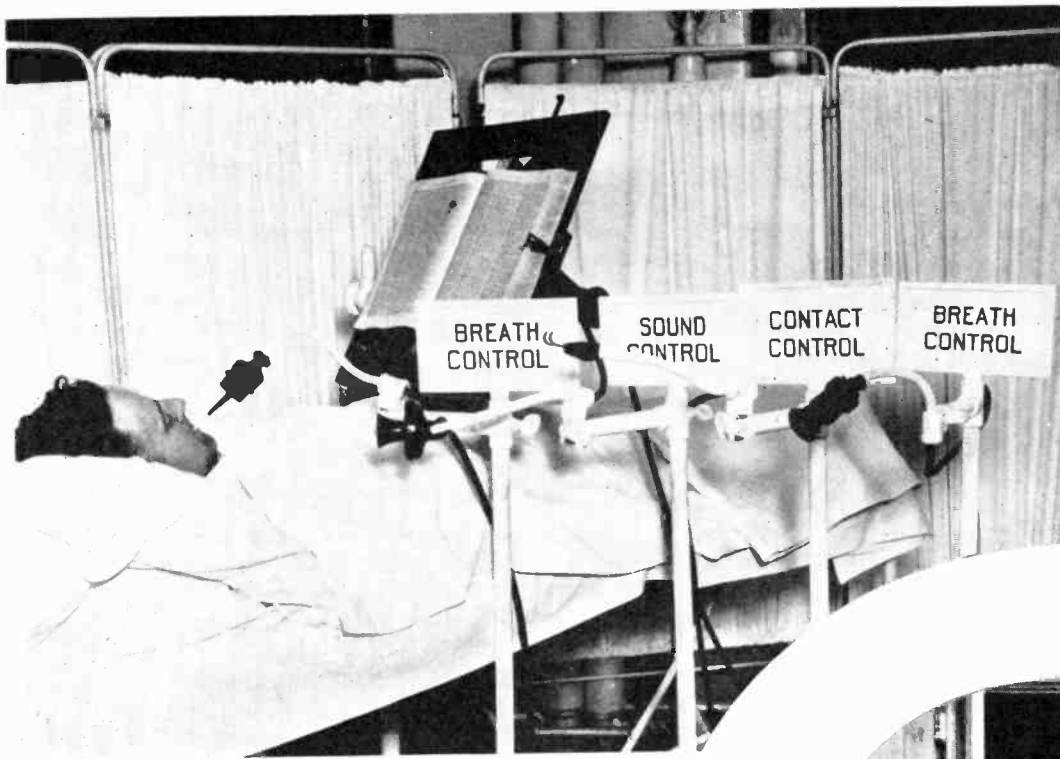

These various forms of control were developed for the use of a boy who is totally paralyzed from the neck down, so that he cannot move even a finger. But by touching his tongue to the electrodes leading to a "contact relay," or by blowing his breath or uttering a sharp sound, the book, radio, lights or call-bell can be manipulated.

ELECTRONIC AIDS FOR THE PARALYZED

Above and below are shown new electronic-amplifier devices in use at the Reconstruction Hospital, New York City, enabling a totally paralyzed person to turn the pages of a book, switch on the radio or room lights, or call a nurse. At the right is seen the new photo-cell "magic door" for the use of infantile-paralysis patients, just installed at Warm Springs Foundation in Georgia.

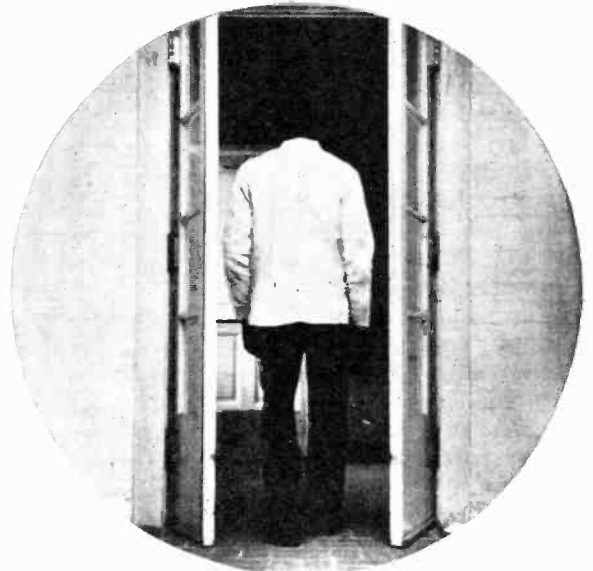

By means of this photo-cell combination, the totally paralyzed boy has merely to move his head into the light-beam to turn the pages of the book. The mechanism goes through a sequence with book, radio, etc. These novel applications were developed by J. S. Doyle, electrical engineer, Interborough Rapid Transit Company, working with Dr. J. J. Moorhead, noted surgeon.

A-C operated high gain amplifiers

By DANIEL E. NOBLE

Assistant Professor Mechanical Engineering
Connecticut State College

WHEN in the early days of broadcasting rectified a.c. power devices were designed to supply the high voltage for the transmitting tubes, many engineers insisted that it was impossible to produce a hum-free carrier from a rectified a.c. power source. While it is still possible to produce a hum-modulated carrier with rectifier operated transmitters, it is generally admitted that the presence of hum is a matter of faulty design rather than a matter of necessity.

We have had, and in fact we are still having, a somewhat similar response to the suggestion that a.c. operated amplifiers be used in broadcast stations and for portable pick-up amplifiers. For many years all low level high gain amplifiers were operated from a battery source. Within the past few years rectified a.c. has been used successfully for the amplifier plate supply. Some stations have installed low voltage rectifier systems to supply the amplifier filament current. Few stations are equipped to operate without batteries and very few stations operate amplifiers with a.c. on the filaments or heaters. Now that manufacturers are offering amplifiers—low level high gain amplifiers—which operate with alternating current on the heaters many engineers are wondering what trick has been used to make a.c. heater operation possible. They reason that it might be possible to use an a.c. operated amplifier to amplify the output of a carbon microphone, but the output of condenser, dynamic and ribbon microphones is so far down that any trace of hum introduced would be amplified to an objectionable degree.

Hum-free amplifiers

NEW TUBES have made possible a-c operated amplifiers as quiet as though powered from batteries. Professor Noble describes amplifiers useful in broadcast stations or for measuring heart-beats!

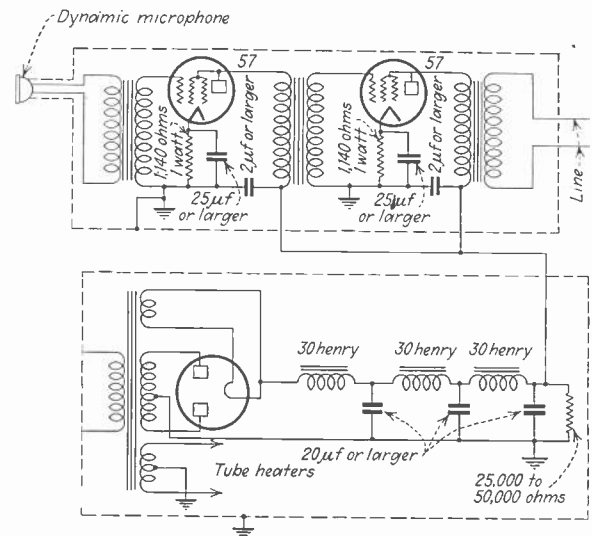

Fig. 1—A ribbon or dynamic amplifier for operation from a.c. supply

The truth is that no trick is required; if no hum is introduced into the amplifier input there will be no amplification of hum whether the gain is 30 db. or 90 db. With the new tubes available it is possible to design amplifiers operating with a.c. in the heaters and rectified a.c. in the plate circuit so that they may be used interchangeably with battery operated amplifiers without introducing measurable hum.

A common mistake made by engineers who use amplifiers but do not design them is the conclusion that a battery operated amplifier may be used anywhere without the introduction of hum pick-up problems. An unshielded battery operated amplifier will operate without a.c. hum in the middle of a vacant lot or in any place isolated from all wires carrying alternating current. In a studio or operating room within range of magnetic or electro static fields from 60 cycle source, the battery operated amplifier will hum noisily unless completely shielded.

In the studio at WCAC a battery operated amplifier was used to boost the output of a W.E. dynamic microphone. When the unit was first placed in use a slight hum

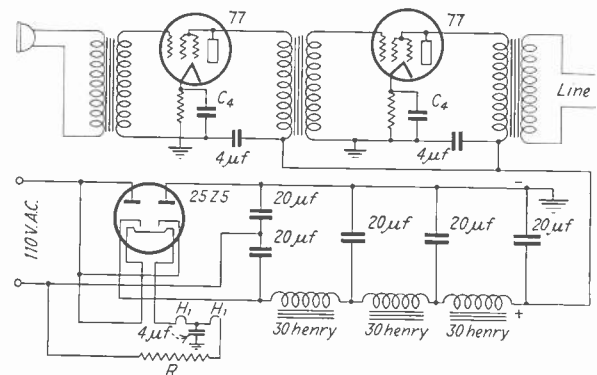

Fig. 2—Compact a.c. operated amplifier employing a voltage doubling tube

could be heard. The amplifier was supposed to be completely shielded but investigation disclosed that the heavy porcelain socket used to take the microphone plug (the standard W.E. plug was not in use) left an inch of input lead unshielded. The installation of a copper hat over the socket completely eliminated the hum. Amplifiers operated from d.c. are admittedly used to advantage where

studio arrangements have eliminated all a.c. Since, however, the great majority of stations are equipped with a.c. lighting circuits the a.c. amplifier will eventually be used widely to simplify installation and maintenance in the studios, the remote pick-up points and in the transmitting stations.

Complete broadcasting stations may now be designed for power outputs of several thousand watts with all units from microphone to antenna operated, figuratively speaking, from the a.c. light socket.

The use of the amplifiers described below is by no means limited to broadcasting; they may replace battery operated equipment on control devices, replace or supplement the amplifiers used by research men in psychology, biology, physics, and other fields. They may be used in public address systems. Nothing new is claimed for the amplifiers to be described, but the astounding lack of information on the subject of a.c. operated amplifiers for high gain at low levels leads the writer to conclude that many broadcast engineers and investigators have mistakenly associated these amplifiers with loud and objectionable hum.

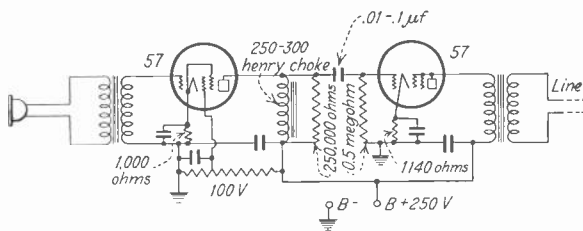

Fig. 3—A pentode amplifier using two 57 type tubes with an over-all gain of 70 db.

There are three factors which must determine the success of a.c. operated amplifiers. They are:

1. Selection of the proper tubes.
2. Complete shielding.
3. Isolation of all power transformers.

The tubes must be so constructed that alternating current passing through the heater will not induce voltage on the grid. The type 57 and 77 tubes fill this requirement very satisfactorily. The helical wound heaters eliminate stray fields from the region of the grid and the isolated grid lead at the top of the tube makes it possible to keep all grid connections well away from the a.c. heater connections. Since all of the tube elements are brought out, it is possible to connect the tube for either triode or pentode operation.

The characteristics of the 57 with triode connections (screen and suppressor grids connected to plate) are given below. The measurements were made in the radio laboratory of Connecticut State College and checked against data supplied by RCA Radiotron Company:

Filament Voltage	2.5 volts
Plate Voltage	250 volts
Control Grid Voltage	-8.0 volts
Plate Current	7 milliamperes
Amplification Factor	21
Plate Resistance	10,500 ohms
Mutual Conductance	2,000 micromhos
Load Resistance	15,000 ohms
Power Output	300 milliwatts

The low plate impedance and high amplification factor of the 57 when used as a triode make it an excellent tube for amplifier work. Standard high quality coupling transformers may be used for a flat frequency characteristic from 30 to 10,000 cycles. With such a set up

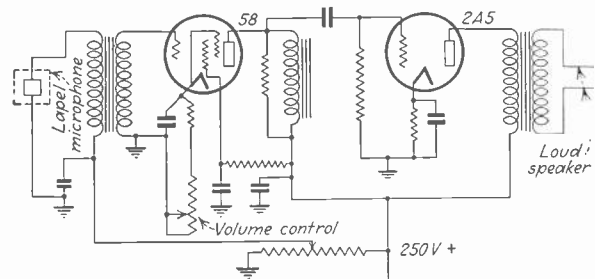

Fig. 4—Public address amplifier with an output of 3 watts operated from a lapele microphone.

as diagrammed in Fig. 1, the approximate gain from grid of the first tube to plate of the last would be 800 times or 58 db. Figure 3 shows a two-tube amplifier with impedance coupling. An amplifier similar to this is in use at WCAC as a preamplifier for a Western Electric dynamic microphone. The broadcast engineer will understand that the hum and noise level is low when it is explained that with headphones, across the amplifier output, clamped on tightly a whisper originating twenty feet from the dynamic microphone may be heard clearly in the phones but no hum can be heard.

The amplifier shown in Fig. 1 is ideally suited to the preamplification of dynamic and ribbon microphone outputs and it may readily be adapted for condenser microphone amplification. The important points of design are listed below:

1. 57 tubes, triode connection.
2. Heater connections in lead cable on the under side of a copper chassis.
3. All grid connections above chassis and completely isolated from heater connections.
4. Bias resistors shunted by 25 μ f or larger electrolytic condensers to reduce degeneration on low frequencies. (Decoupling filters may introduce hum.)
5. Amplifier completely enclosed in a copper case.
6. Input completely shielded connecting to completely shielded microphone.
7. Heater and high voltage supply isolated from amplifier (3 ft. or more) and feeding through shielded cable.
8. Completely filtered high voltage supply.

The frequency characteristics of the amplifier will depend upon the specifications of the transformers used. It has been assumed that shielded transformers will be used. Properly set up, this amplifier will operate without producing hum.

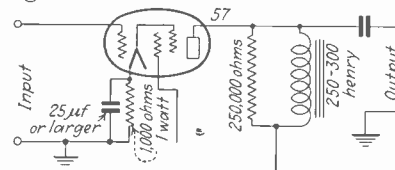

Fig. 5—Impedance coupled amplifier for high gain.

The power supply must be hum free. Tuned filter sections might very easily be designed to make satisfactory compact hum-free units. The power supply used at WCAC is not compact. Several 20 μ f condensers and 30 henry choke coils were available in the laboratory; they were combined into the unit shown in the diagram. The results were entirely satisfactory.

Perhaps it would be well to emphasize the fact that the 60 cycle power transformer is a very effective hum

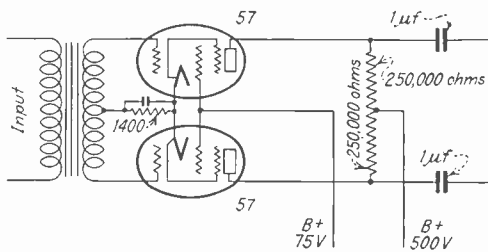

Fig. 6—Amplifier for high gain, low distortion, low noise and low hum.

producer when placed nearer than twelve inches from the amplifier. Copper sheet acts as an effective electrostatic shield. It is much more difficult to shield the amplifier from magnetic fields. Heavy iron shields of high permeability would probably be effective but it is a much more simple solution to keep magnetic fields away from the amplifier.

Voltage-doubler and pentode amplifiers

Where a compact amplifier complete with power supply in a single container is required, the outfit may be designed without power transformers. Such a combination is shown in Fig. 2. Type 77 tubes are used with a 25Z5 voltage doubler. With this arrangement it is possible to operate the power supply near the amplifier without producing hum if the amplifier is properly shielded in a sheet copper case.

However, the adjustment of parts to eliminate hum with the series connection of the heaters is difficult. The best solution is the use of the parallel low voltage connection to the heaters leading to a small heater transformer built into an oversize plug at the end of the a.c. cord. If the building of the transformer into the assembly is essential to the use for which the amplifier is designed the problem may be solved by enclosing the small filament transformer in a heavy case of high permeability iron and enclosing the whole in a second case of copper insulated, except at one point, from the iron. It is obvious that the filter choke coils should be shielded.

The characteristics of the type 77 tube are similar to those of the 57. An amplifier designed around the 77 tube may be operated with either a.c. or d.c. in the heaters. Push pull circuits may be used in any combination to increase the output or to balance out the hum in amplifiers of faulty design.

If the points of design listed are carefully followed a.c. operated amplifiers using resistance, transformer, or impedance coupling will give the desired no-hum operation at low level with very high amplification.

So far only the triode connection has been considered. The pentode connection is equally satisfactory in so far as the lack of hum production is concerned. Figure 3 shows a pentode amplifier used in the Connecti-

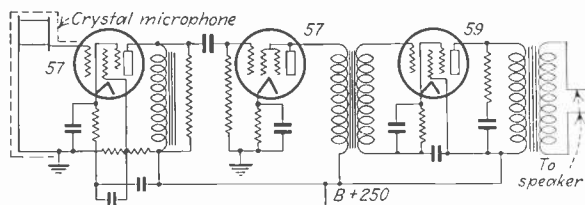

Fig. 7—Amplifier used in Zoology Department of the Connecticut State College for listening to heart beats and other cavity noises. Crystal microphone is mounted in sponge rubber.

cut State College radio laboratory. The change from triode to pentode connection did not change the hum level but it did very greatly increase the amplification. A single 57 pentode feeding a single 57 triode gave an amplification of the order of 70 db. The dynamic microphone could not be used in the combination—even comparatively low level sound at the microphone overloaded the grid of the second tube. In a somewhat similar set up a single 57 pentode was used to excite a 2A5 pentode. The W.E. dynamic supplied sufficient input to operate a loudspeaker at full volume. Later a 58 tube was substituted for the 57 as show in Fig. 4. With the volume controlled by the variable bias resistor the outfit proved to be a very effective public address system for use with the W.E. dynamic or lapel microphone.

The use of the tubes in the pentode connection requires additional precautions:

1. Shield the tubes; shield all coupling units and shield leads to the tubes.
2. Low capacity shielded cable must be used if the shielding is to be installed without attenuating the response at high frequencies.

The pentode may be used with either resistance or impedance coupling. For highest possible amplification the impedance connection shown in Fig. 5 is recommended. For high amplification at lowest distortion the push pull connection of Fig. 6 is recommended.

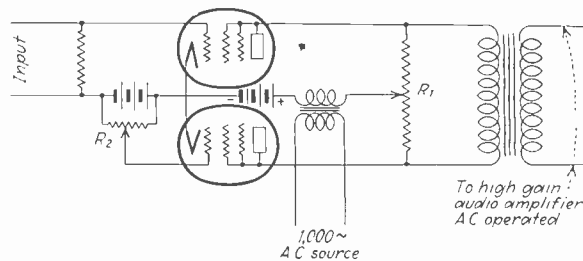

Fig. 8—Circuit for detecting and recording very small voltage changes.

An advantage to be gained in addition to high amplification, by use of the pentode connection, is the low noise level. The fundamental low noise requirements, high amplification and low plate current in the first stage, are satisfied by the use of the 57 pentode.

Figure 8 shows a circuit for detecting and recording very small voltage changes. In operation R_2 is adjusted until no a.c. appears across R_1 . An input voltage then produces across R_1 a 1000-cycle potential which may be amplified. The output of the audio amplifier may be connected to a dynamometer type meter or to recording equipment.

The amplifier will work successfully in many applications but it must be remembered that this amplifier, in common with all other amplifiers, must be used with the input attached to a completely shielded source whether the source be a microphone, a plant or a man. If a research problem does not allow the use of extensive shielding the set-up should be made at some point isolated from a.c. disturbances.

With a.c. disturbances eliminated the complete set-up may be made with battery amplifiers and the input may be connected without extensive shielding. The alternative method using either a.c. or battery operated amplifiers would be the use of shielded cable from the amplifier to a point free from a.c. strays. The input could then be applied without shielding the source undergoing the investigation.

Processes in vacuum tube manufacture

Exhaust—carbonizing—ageing

By E. R. WAGNER, Ph.D.

Consulting engineer

In April ELECTRONICS, Dr. Wagner discussed the selection and treatment of raw materials used as plates, grids and filaments.

THE baking out process is essentially one of removal of absorbed moisture from the glass, but the reasons for its removal are in part at least chemical, since water vapor, liberated after the tube has been put into service, attacks the active coating of the filament, to cause rapidly falling emission, and rapid tube deterioration.

Filament conversion is entirely chemical in nature. The ordinary coating, which consists of barium and strontium carbonates bound together with barium nitrate, is converted by heat to barium and strontium oxides. Carbon dioxide, and smaller amounts of oxides of nitrogen, are given off and are pumped out. If the filament coating is quite dense and the heating current is increased too rapidly, the sudden liberation of gas at the interface between metal and coating can build up pressure enough to bring about a separation of coating from the filament. It may be violent enough to cause the coating to drop off entirely, or it may simply result in poor contact between oxide and metal. Decreased emission and decreased life are the consequences.

Again, if filament conversion has not progressed almost to completion before external bombardment takes place, the atmosphere within the bulb will contain sufficient carbon dioxide to oxidize the plate and grid. The oxide, (of nickel especially) is a good insulator. Its effect on the grid is of no consequence, since the grid acts electro-statically, but an oxidized plate will mean considerable decrease in emission test, mutual conductance, and plate current. The μ will tend to increase slightly but probably not enough to bring it outside of permissible limits. The decrease in G_m and in plate current may be great enough to cause rejection of the tube. Even if the characteristics are still within prescribed limits, the oxide on the plate will liberate oxygen when the tube is in operation, and falling emission will again occur.

Where lacquer-bound coating is used, a different sort of trouble occurs due to the condensation of solvent—especially high-boiling solvent, on the cooler parts of the tube. A commercial lacquer usually contains dibutylphthalate or tricresyl-phosphate, as plasticizers. Their presence is absolutely necessary in an automobile finish, but unnecessary in cathode coatings. Their boiling points are around 300° C., and unless the glass remains hot enough to prevent them from condensing upon it, they may bring about troublesome gas liberation. The most trouble, however, comes from the destructive distillation of the collodion. A heterogeneous mass of tars and pitch results from this decomposition and substances with higher boiling points than can conveniently be pumped out frequently condense on the grid and plate.

Part of this layer may remain even through an in-

tense external bombardment, or it may simply be transferred to the glass, and then slowly settle back on the plate. The result is decreased G_m and plate current. A tube may be rejected. The gas liberated by this tar layer is not as destructive to the filament as is oxygen from an oxidized plate, but it does cause a "gassy" tube with its resultant erratic behavior.

Carbonized plates are frequently troublesome, causing low G_m ; as much as 200 micromhos below the value obtained when a bright metal plate is used. This is due to a complex hydrocarbon deposit, that forms during carbonization. When such a plate is heated in hydrogen, the trouble is often worse.

This brings us to the question of "getters." The explosion of the getter is supposedly the final step in cleaning up residual gases in a tube, but every tube maker knows that it is merely a help, and that it may, if not properly placed, ruin a tube through leakage caused by excess metal condensing on the stem. Magnesium is the commonest getter. It is extremely active, in vaporized form, and will even combine with hydrocarbons. In this respect it is superior to barium. On the other hand, it has little or no value as a "keeper" and will not react with gases other than oxygen, after

[Please turn to page 229]

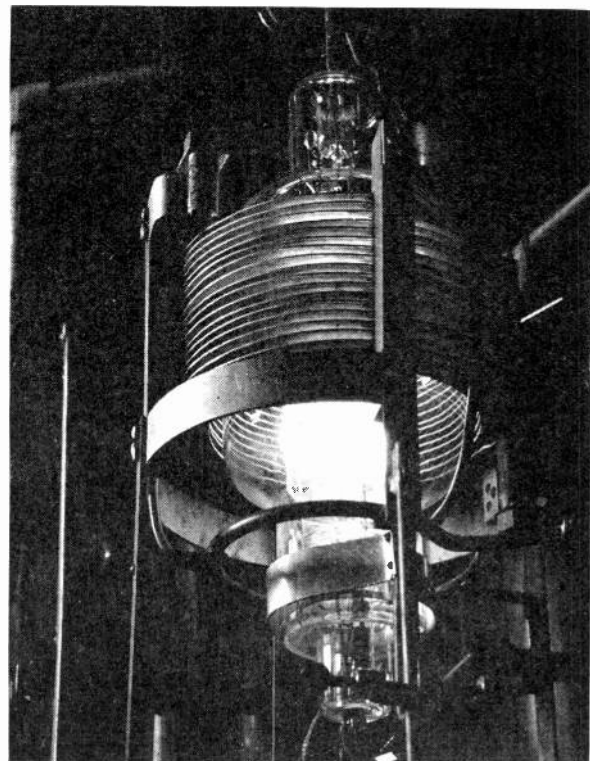

Bombarding a power tube—an important process—in the Bell Telephone laboratories.

Vibrator power supply from dry cells

By WALTER VAN B. ROBERTS

Radio Corporation of America

THE buzzer type of high voltage supply seems to be desirable for battery-operated receivers because it allows the use of a single battery for the entire power supply. Being composed of relatively few units, such a battery should have a longer "shelf life" and give more watt-hours per dollar than high voltage B batteries. Furthermore, it may be made up of ordinary dry cells which are available at stores in nearly all small towns.

The object of this paper is to develop formulæ giving the performance of a simple idealized supply system. The performance so calculated indicates what may be approached by proper design. Circuit constants for a given performance may be discovered by "cut and try" methods, using the formulæ for the "try" part of the method.

Figure 1 is the circuit diagram of the system, with a table of symbols used and assumptions made as to circuit constants and operation. The symbols used are defined as follows:

R_B = battery resistance
 R_P = primary coil resistance
 $R_1 = R_B + R_P$ = resistance of entire primary circuit
 R_2 = secondary coil resistance
 S_1 is assumed to close for a time T , then to open for a time $P-T$, etc.

S_2 is assumed to act as a perfect valve, being open while S_1 is closed, closing just as S_1 opens, remaining closed until the current pulse in the secondary ceases and then opening again.

P is the period of operation of S_1 , which is the "buzzer" of the system

$$\Theta = \frac{T}{P} = \text{the fraction of the full period that the battery works}$$

$$\phi = \frac{TR_1}{L_1} = \text{the ratio of working time } T \text{ to the time constant}$$

of the primary circuit

ξ = primary circuit efficiency = the ratio of kinetic energy stored in L_1 per cycle to the total energy drawn from the battery per cycle.

ψ = ratio of energy dissipated in R_2 per cycle to energy delivered to the filter input condenser.

W = kinetic energy stored in L_1 per cycle = energy delivered to secondary per cycle

E_2 = voltage across filter input condenser and is assumed to be kept nearly constant by employing a large condenser.

i_0 = initial value of secondary current, which is also its peak value. The transformer windings are assumed to be 100 per cent coupled, and iron losses to be neglected

Qualitatively, the action of the circuit is as follows: Switch S_1 closes for a length of time T during which time current builds up in the primary circuit. Some of the energy drawn from the battery during this time is dissipated in R_1 , but the majority of it is stored as kinetic energy in L_1 . At the end of time T switch S_1 opens, while S_2 simultaneously closes. When the primary current is interrupted, a secondary current must flow to correspond with the energy W stored up in the transformer field. The secondary current starts with a value i_0 given by $\frac{1}{2} L_2 i_0^2 = W$, and then dies away due to the resistance and opposing voltage E_2 in the secondary circuit. The length of time the secondary current flows before falling to zero depends upon its initial value and the constants of the secondary circuit, including the value of E_2 . We will assume that these factors are so chosen that the secondary current falls to zero before switch S_1 closes again. That is, the duration of the secondary current pulse is less than $P-T$, and hence S_2 opens before S_1 closes again.

What we wish to determine quantitatively is the average power drawn from the battery, and average power delivered to the filter input. Since the power dissipated in the secondary = ψ times power delivered to filter, the power transferred from primary to secondary must be $(1 + \psi)$ times power delivered to filter. But the transferred power is ξ times the power drawn from the battery. Hence we have:

$$\text{Power delivered to filter} = \frac{\xi}{1 + \psi} \text{ times power drawn from battery, and obviously}$$

$$\text{Overall efficiency} = \frac{\xi}{1 + \psi}$$

These quantities may be determined from the following equations whose derivations will be given later:

$$\text{Power drawn from battery} = \frac{W}{\xi P} \dots \text{eq. 1}$$

$$\xi = \frac{\frac{1}{2} (1 - e^{-\phi})^2}{\phi - (1 - e^{-\phi})} \dots \text{eq. 2}$$

$$W = \frac{\Theta PE_1^2 F}{R_1} \quad \text{where } F = \frac{(1 - e^{-\phi})^2}{2\phi} \dots \text{eq. 3}$$

$$\psi = \frac{\frac{1}{2} r^2 - [r - \log_e(1 + r)]}{[r - \log_e(1 + r)]} \quad \text{where } r = \frac{R_2}{E_2} \sqrt{\frac{2W}{L_2}} \dots \text{eq. 4}$$

$$\text{Duration of secondary current pulse} = \frac{L_2}{R_2} \log_e(1 + r) \dots \text{eq. 5}$$

$$\text{Peak value of secondary current} = \sqrt{\frac{2W}{L_2}} \dots \text{eq. 6}$$

For convenience ξ and F are plotted as functions of ϕ in Fig. 2.

Efficient power for portable radio receivers

THAT six dry cells are sufficient for the entire power supply of a loudspeaking portable radio receiver is indicated in this analysis, a fact of timely interest to vacation-bound listeners

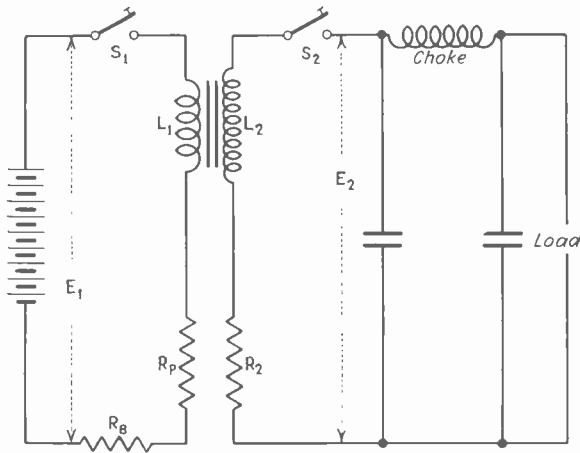

Fig. 1—Circuit for vibrator power supply.

Application to a typical case

As an example of the use of eqs. 1 to 6, let us suppose we have a system with constants arbitrarily chosen as follows:

$$\begin{aligned} \phi &= 1/2 & E_1 &= 2 & R_1 &= 1/10 \\ \Theta &= 1/3 & E_2 &= 200 & R_2 &= 400 \\ P &= 1/100 & & & L_2 &= 16 \end{aligned}$$

From Fig. 2 we find $\xi = .73$ and $F = .15$
 From eq. 3 we have $W = \frac{1/10}{1/50} = 1.50$

From eq. 1 we have battery drain $= \frac{.73 \times 1/100}{400 \sqrt{2/50}} = 2.74$ watts

From eq. 4 we find $r = \frac{200 \sqrt{2/50}}{16} = 1/10$

From eq. 4 $\psi = .066$

Overall efficiency $= \frac{\xi}{1 + \psi} = \frac{.73}{1.066} = .684$

Power delivered to filter $= 2.74 \times .684 = 1.88$ watts

Peak value of secondary pulse $= \sqrt{\frac{2/50}{16}} = \frac{1}{20}$ ampere

Duration of secondary pulse $= \frac{16}{400} \log_e \left(1 + \frac{1}{10} \right) = .0038$

which is comfortably less than $P-T$ which is .0066.

Let us next consider the effect of replacing the resistanceless switch S_2 by a rectifier. If the rectifier has a resistance which is approximately constant throughout the secondary current pulse, its resistance could be lumped with the secondary coil resistance and the equations would be applicable without change. On the other hand, if the voltage drop across the rectifier is constant, E_2 may be taken as the voltage of the filter input condenser plus the drop across the rectifier. Again the equations apply except that since the power is delivered to the filter at a lower voltage than E_2 , the power delivered to the filter will be $\frac{E_F}{E_2}$ times the power given

by the equations, where E_F is the voltage across the filter condenser. The overall efficiency will of course be reduced in the same proportion. Actual rectifiers do not fall into either of these classes, but should behave in an intermediate fashion. Since the peak rectifier current is known, it should be possible to assume either an average resistance value or an average voltage drop for the rectifier that would give fairly close results.

From the foregoing it would appear possible to operate a loud speaking portable receiver on six dry cells if long battery life is not essential.

Derivation of equations

The growth of primary current is given by the well known expression $i = \frac{E_1}{R_1} (1 - e^{-\frac{R_1 t}{L_1}})$

The energy stored in L_1 at the end of time T is therefore

$$\frac{1}{2} L_1 i^2 = \frac{1}{2} L_1 \frac{E_1^2}{R_1^2} (1 - e^{-\phi})^2$$

since $\phi = \frac{TR_1}{L_1}$

The total energy developed by the battery in time $T =$

$$\int_0^T E_1 i dt = L_1 \left(\frac{E_1}{R_1} \right)^2 \left\{ \phi - (1 - e^{-\phi}) \right\}$$

The efficiency ξ is therefore $\frac{\phi - (1 - e^{-\phi})}{\frac{1}{2} (1 - e^{-\phi})^2}$ which for convenience in plotting for small values of ϕ may be expanded into

$$1 - \frac{2}{3} \phi + \frac{5}{18} \phi^2 - \frac{13}{270} \phi^3 + \dots$$

The expression for stored energy given above may be rewritten as

$$W = \frac{1}{2} \frac{E_1^2}{R_1} \frac{\Theta P}{\phi} (1 - e^{-\phi})^2 = \frac{\Theta P E_1^2 F}{R_1 \phi} \text{ where } F = \frac{\frac{1}{2} (1 - e^{-\phi})^2}{\phi}$$

and for small values of ϕ this may be expanded

$$\frac{1}{2} \phi \left(1 - \phi + \frac{7}{12} \phi^2 - \dots \right)$$

The secondary current is given by the expression

$$\frac{E_2}{R_2} - \left(\frac{E_2}{R_2} + i_0 \right) e^{-\frac{R_2 t}{L_2}}$$

which expression reduces to $-i_0$ the initial value for $t = 0$ and reaches a steady value $\frac{E_2}{R_2}$ for $t = \infty$. It passes through zero at

$$t = \frac{L_2}{R_2} \left(\log_e \left(1 + \frac{i_0 R_2}{E_2} \right) \right)$$

the work delivered to the filter is $-\int_0^T i_2^2 dt$ which reduces to

$$L_2 \left(\frac{E_2}{R_2} \right)^2 \left\{ \frac{i_0 R_2}{E_2} - \log_e \left(1 + \frac{i_0 R_2}{E_2} \right) \right\}$$

The energy dissipated in R_2 is $\int i_2^2 R_2 dt$ between the same limits,

$$\text{which reduces to } L_2 \left(\frac{E_2}{R_2} \right)^2 \left[\frac{1}{2} \left(\frac{i_0 R_2}{E_2} \right)^2 - \left\{ \frac{i_0 R_2}{E_2} - \log_e \left(1 + \frac{i_0 R_2}{E_2} \right) \right\} \right]$$

The ratio of these expressions is ψ and is given at equation 4. For plotting for small values of r , eq. 4 expands into

$$\frac{2}{3} r - \frac{1}{18} r^2 + \frac{8}{270} r^3 - \dots$$

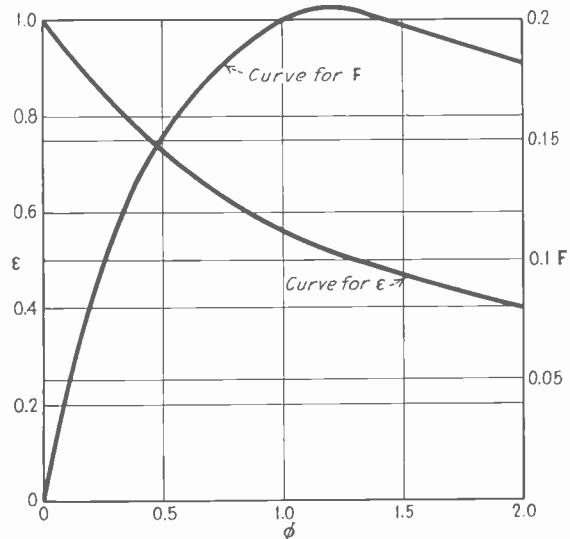

Fig. 2—Curves for F and ϵ , referred to in text.

HIGH LIGHTS ON ELECTRONIC

Teaching pilots "blind flying" in radio beam

A RADICALLY NEW method of teaching "blind" flying and radio-beam navigation now enables pilots to receive most of their training without leaving the ground. This novel device is in use training U. S. Army air mail pilots and others at Newark Airport, and because of its success is being adopted by the government for use in various locations. It consists of a dummy plane mounted on a pedestal equipped with complete blind flying instruments and radio, and a remote instructor's unit for the checking up and guidance of the student pilot in his "flight" inside the hangar.

The pilot is strapped in his plane in the usual manner and the cockpit is entirely enclosed by means of a hinged cover. By pressing a button the instructor places the plane in flight condition and the pilot in the plane, using only the standard plane controls, must take off, "bank" and, in fact, make a complete "flight," without leaving the ground. The invention is the work of E. A. Link, a former manufacturer of player pianos and it is interesting to note that air bellows similar to those used in player pianos, actuate the plane and make it take off, bank, speed up, turn around, etc., during its flight, all controlled by the pilot's "stick." While the flight is in progress an instructor

sits at a position in close proximity to the plane and observes how the pilot keeps on his course. Enclosed in a receptacle on the instructor's desk is a device which automatically sends forth four miniature radio beams the course of which the pilot in the plane is supposed to follow. The device is now in use at the Casey Jones School of Aviation at Newark Airport and eliminates 60 per cent of the time necessary to teach a pilot "blind" flying.

★

Electronic methods in geophysical prospecting

THE EDITORS of *Electronics* are continually receiving inquiries from readers and others for the names of engineers who are familiar with geophysical prospecting methods and who are equipped to make use of or give advice on electronic and similar devices in locating underground minerals, ores, oil deposits, etc., as well as for investigating underground footings for dams and other heavy structures, locating buried structures, water mains, gas pipes, conduits, etc.

Accordingly we reproduce below a list of consultants in geophysical prospecting, prepared by the editors of our sister publication *Engineering and Mining Journal*. These consultants employ

the various geophysical methods suitable for the problem in hand, including methods making use of electronic apparatus:

Consultants in geophysical prospecting
Swedish-American Prospecting Corporation, 26 Beaver St., New York City.
Compagnie Generale Geophysique c/o W. E. Miller, International Ores & Metals Co. 60 Broad St., New York (Cie. Gen. Geophysique handle the Schlumberger electrical prospecting methods).
Also Compagnie Generale Geophysique c/o E. G. Leonardon, 1604 Sterling Bldg., Houston, Texas.
The Radiore Company, Palmer Bldg., Hollywood, Calif.
Physical Exploration Corporation, 1865 Monroe St., Madison, Wis. also 111 B'way, New York City.
Geophysical Exploration Corporation, 30 Church St., New York.
North American Exploration Company, 71 Broadway, New York City.
Geophysical Company of Canada, Ltd., 703 Reford Bldg., Toronto, Canada.
Geophysical Company, Ltd., London, England.
Geophysical Research Corporation, 120 Broadway, New York City.
Combined Geophysical Methods, Inc., 50 E. 42nd St., New York (formerly Low, Kelly & Zuschlag).
Noel H. Stearn, W. C. McBride, Inc., Missouri Pacific Bldg., St. Louis, Mo.
Wm. M. Barrett, Giddens-Lane Bldg., Shreveport, La.
Donald C. Barton, Petroleum Bldg., Houston, Texas.
International Geophysics, Box 144, Palms Station, Los Angeles, Calif.
Petty Geophysical Engineering Co., 706 Travis Bldg., San Antonio, Texas.
Rosaire & Kannenstine, Esperson Bldg., Houston, Texas.
Torsion Balance Exploration Co., Post Dispatch Building, Houston, Texas.
W. P. Jenny, 6291 Richmond Ave., Dallas, Texas.
McCullum Exploration Co., Esperson Bldg., Houston, Texas.
Karcher & McDermott, Republic Bank Bldg., Dallas, Texas.
S. G. Sargis, Provo, Utah.
Schlumberger Company, 906 Sterling Building, Houston, Tex.
Schlumberger Electrical Prospecting Methods, 70 Pine Street, New York, N. Y.

★

Intelligible explanations instead of buzzes for phone users

IN AMERICAN TELEPHONE PRACTICE, when a calling subscriber gets a busy line, or one out of order, or "no answer," he is expected to recognize any one of a code of buzz signals, indicating to the initiated just what the trouble is that he cannot get his call. Telephone men understand these buzz signals and assume that the general public understands and interprets them.

But in England the British Post Office research department has developed a photocell arrangement to give the calling subscriber an intelligible explanation, in plain English, of what difficulty his call is experiencing.

On continuous-belt films, voice recordings have been made of such phrases as "Number engaged," "Number unobtainable," and so on, and these explanatory messages are automatically

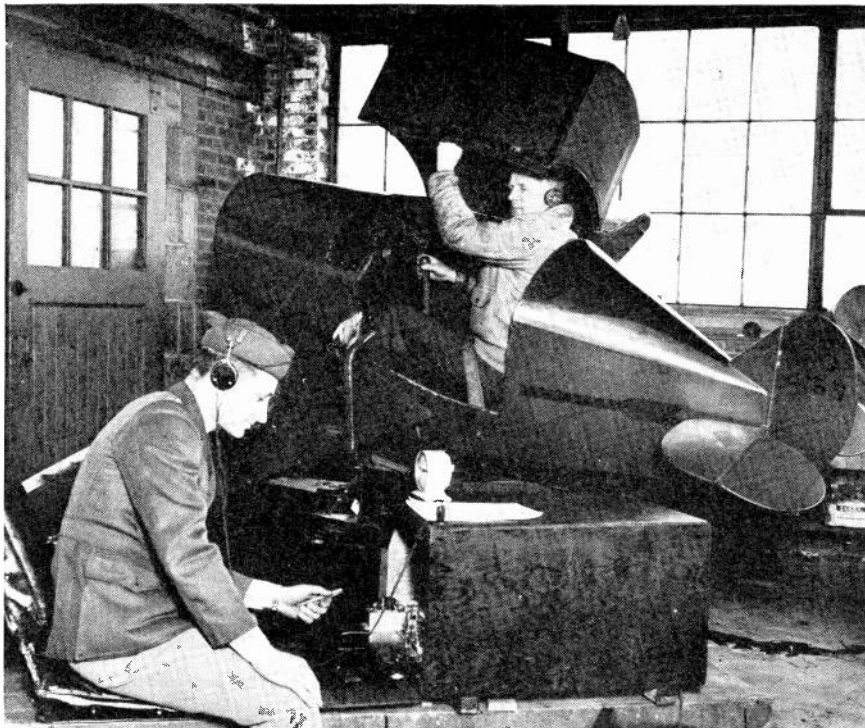

The equivalent of miniature radio beams serve to guide the pilot during his indoor instructional "blind flight"

DEVICES IN INDUSTRY + +

switched on by the operator, instead of the buzz-buzz, and buzz-buzz-buzz signals used in American telephone exchanges. The pick-up from the films is of course by photo-cell, following standard sound-picture practice. Several replies are recorded side by side on the film, and the switching circuits pick out the one corresponding to the condition of the calling circuit.

+

Backstage sound effects for theatres

THE LEGITIMATE THEATRE has recently been taking advantage of technical developments to enhance the value of the entertainment it offers, notably sound recordings for "back-stage" effects.

An outstanding instance was the effective use by Norman Bel Geddes of a sound system for providing music and sound effects for his stage production of "Hamlet." Eight records were used to provide the music and various other sounds incidental to the action. Some of the records contained as many as eight different recordings of sound effects. One record consisted entirely of various sounds of the howling and whistling of wind.

Two turntables were used so that two different sound effects closely following each other could be reproduced without delay. Provision was also made to superimpose the sounds from the record on one turntable on those from the record on the other turntable. This was required, for instance, when the voice of the "ghost" and the wailing of the wind were reproduced from one record at the same time music was being reproduced from the other.

There were five horns on the stage—one on each side and three, properly spaced, in the rear. The operator could select any or all of the horns as required, according to the direction from which it was desired to have the sound appear to come. For instance, when the crowd climbed the mountain to storm the castle, there were murmurings and shouts heard dimly in the distance. They became louder and followed the crowd as they circled around the mountain, until finally the sounds blended into the stage action as the crowd, rushing on the stage, carried on in loud voices. To produce this effect, the crowd sounds were first reproduced from the horn at the left of the stage until a certain volume was reached. Then the next horn in order was turned on and the volume increased somewhat when the third horn was then decreased and, as the other horns were added, it was

turned off entirely. In this way, the sound appeared to rotate around the stage to follow the approach of the crowd.

In the scene in which the traveling minstrels presented a travesty on the murder of Hamlet's father, the music for the dancing and singing was provided by the sound system. Reproduction throughout the entire show was so realistic that the audience was probably unaware how the sound effects were produced. So real was the sighing of the winds as the king knelt before the cross on the mountain that the audience was noticeably affected.

Sound effects somewhat similar to these are finding increased application in other legitimate productions. In the show "Of Thee I Sing," the noise of a political gathering is reproduced by records.

In Ziegfeld's "Hot-Cha," the noise of the crowd at the bullfight was provided by an electrical recording.

Although the use of the sound system for providing effects is the most spectacular, there are many other no less useful applications in rehearsing and running the show.

Incidental music can be furnished before and after the show and during intermission where no orchestra is used.

Actor's voices can be reinforced, so that they can be heard in any part of the theatre.

In running the show, microphones and loud speakers are a great aid in keeping things moving smoothly. Loud speakers in the dressing rooms reporting the stage action furnish cues for the actors.

While the show is being rehearsed, the director using a microphone can issue instructions to various parts of the theatre.

Lost fishing dories located by radio

IN COOPERATION with a number of Gloucester, Mass., fishermen, Frank Bludworth, 79 Fifth Avenue, New York City, has been conducting experiments to prevent the loss of fishermen's dories, which in fogs sometimes drift away from the point at which the attending vessel leaves them, so that they cannot be found again after the lines are baited, and fishing is completed. In the past, fishermen have often perished as a result of being carried to sea in dense fogs.

Under the new Bludworth plan, each fishing dory or small boat will carry a compact 20-lb. radio transmitter, with a demountable antenna made up of bamboo poles.

Once the dories are through fishing and desire to return to their mother craft, the fisherman will rig the wire on the poles and attach the end of the wire to the binding post on the transmitter. He will then start sending a signal to the mother craft. This will be a steady tone and each dory will be identified by a separate tone.

The mother ship will possess a radio direction finder, and the man at the radio will pick up the tone being sent by the fisherman and get his bearing by means of the finder. The tone distinction for each dory is for the purpose of distinguishing between them in case more than one starts sending at the same time.

Test made on the Dogbar Banks this spring, with the mackerel-netter "Mary M." have shown that lost dories can be located in dense fog at a distance of six miles, and that the dory-transmitter's battery will send signals for a week.

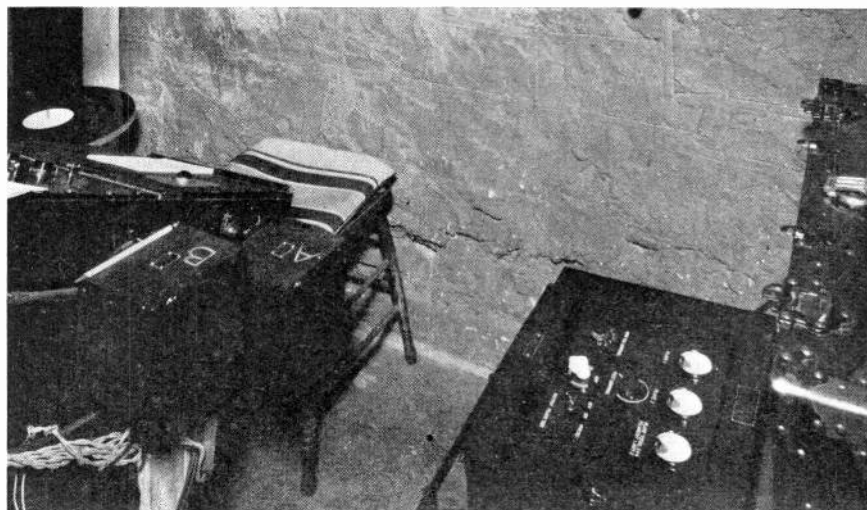

Sound reproducing and amplifier equipment used for "back-stage" sounds in Norman Bel Geddes' "Hamlet"

A mobile printer for police and aircraft radio

It
is 12 inches long, 4 inches on a side
can be used for aircraft or seacraft
operates from 6-volt car battery
prints 30-40 words per minute
can be mounted on auto dash
gives a permanent record
forms a secret system
weigh 8 pounds

●

TWO criticisms of present-day police radio systems are the lack of secrecy, and the lack of a permanent record to prove that the police car for which the message was intended actually received it. At a meeting of the Radio Club of America, June 20, first public disclosure of a simple automatic printer for this service was made by W. H. G. Finch and is described briefly here through the courtesy of the Radio Club.

Mr. Finch's work has developed out of his extended research into printing telegraph systems for the daily newspapers which have in successful operation a number of radio circuits on a basis providing competition with existing wire circuits, transmitting daily thousands of words of press matter.

The device of particular interest to police, or other mobile services, is a printer weighing 8 pounds, operating from the 6-volt automobile car battery, printing 35-40

words per minute on a tape. Thus the officer in the car need not worry about local audible interference; and his memory need not be taxed or handicapped by other local circumstances. This device, when properly actuated by the distant transmitter, will print out the message from headquarters and retain it as permanent proof that it was actually received in the car.

This printed tape record, proceeding behind a simple lens or other projection system, is magnified so that it can be easily read by those in the police car.

Signals from the transmitter, which need be no more powerful than present voice-modulated apparatus, may be coded automatically, changed from day to day if desirable, and decoded automatically at the receiver in the mobile installation. Others listening in could not unravel any of the messages from headquarters, insuring secrecy with advantages to the police system that are obvious.

The work that has led to this simple, light-weight device (consuming but 3 amperes starting and 1.75 amperes running) was carried out in the Finch Laboratories at the Teterboro Airport, Hasbrouck Heights, New Jersey. The applications, as an automatic printer, to the dissemination of weather reports to aircraft in flight, or to inter-vessel communication in a fleet, such as the fishing fleet off Grand Banks, or among Naval vessels or Army networks—in other words to all mobile or stationary points to which teletype might be employed are but natural extensions of the police radio usage.

To add such a recorder to existing equipment would not be difficult, according to Mr. Finch. Existing transmitters and receivers could be used. At the transmitter the addition of equipment to send out the actuating impulses would be necessary and at the receiver the addition of the simple dash-board recorder would be all that is required.

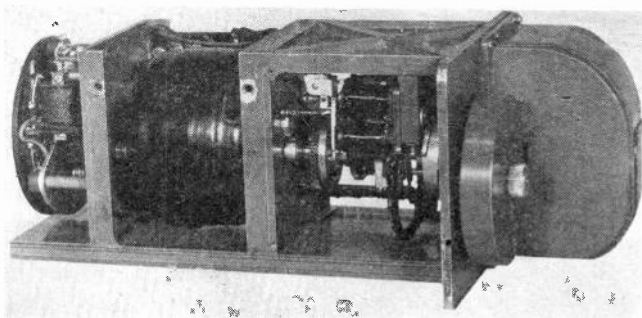

View of Finch mobile printer for police radio, inter-fleet communication or aircraft.

Printer with specimen of tape which is stored in a magazine after it is viewed by the operator.

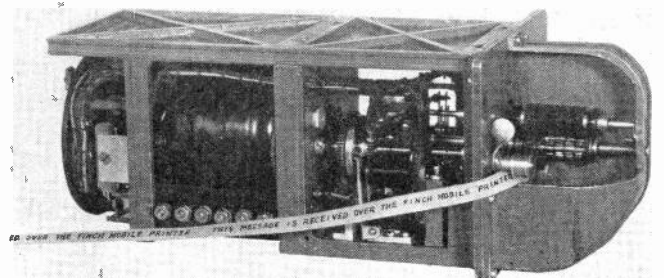

Reactance values of capacitances and inductances for the middle radio frequencies

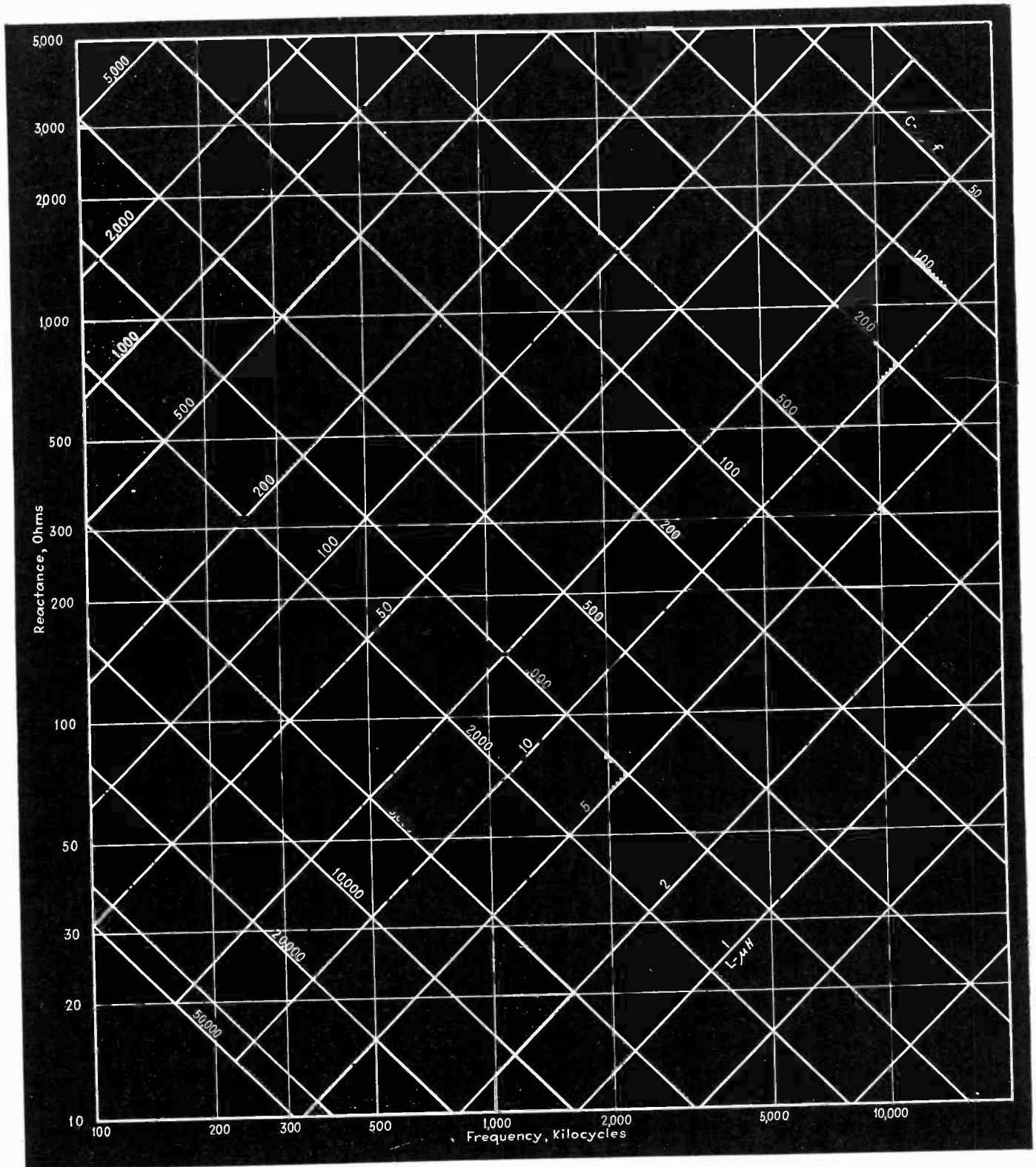

Reactance values corresponding to given values of capacitance and inductance throughout the range of the middle radio frequencies are assembled conveniently in the above chart, compiled by Edmund A. Laport. Associated with each diagonal line is a value of capacitance (C) or inductance (L), the reactance of which at any frequency can be read on the vertical scale. The intersection of two diagonal lines indicates the resonant frequency for the given value of inductance and capacity at that point.

★ ★ NOTES ON ELECTRON

Tube tester par excellence

IN THE WESTON laboratories where commercial tube testers are rated and standardized, an elaborate tube testing instrument assembly has been combined with a source of supply voltages for maintaining accurate potentials on the grid and plate circuits of tubes under test.

The unit is built up around a modified Model 576 mutual conductance meter; the instruments are 7 inch flush type switchboard meters with movements of high precision.

Two power supply devices are used, one for plate voltages and the other for grid voltages, the separation being desirable to prevent any coupling between the two circuits. In each power unit as much as 30 μ f capacity is used to keep the ripple to a negligible quantity. Tubes may have their cathodes heated by a.c. or d.c. Heavy duty vitrified rheostats with verniers are employed, to adjust the voltages to the exact values desired for test purposes.

In measurement, a 1 volt r.m.s. 60 cycle signal is put in series with the grid, and the resulting a.c. component in the plate circuit is measured in an especially calibrated rectifier meter. The entire bridge is accurate from day to day to within 2 per cent; the individual meters to within $\frac{1}{4}$ of one per cent.

Triode r-f amplification

A SYSTEM OF AMPLIFICATION using triodes and claimed to be inherently and unconditionally stable is described by

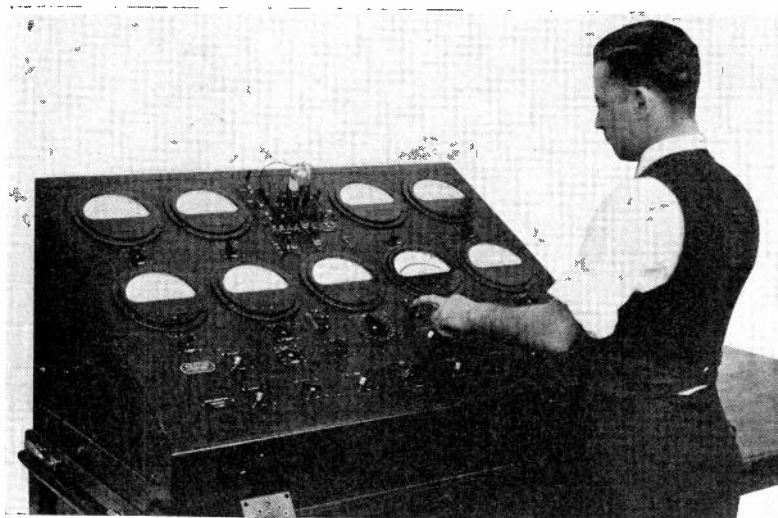

Accurate voltage control is a feature of this elaborate tube tester.

F. M. Colebrook, B. Sc., in a paper published by the British Institution of Electrical Engineers in its Journal No. 446.

Mr. Colebrook, who is connected with the National Physical Laboratory and the Radio Research Laboratory, suggests that the input admittance of the triode should be stabilized by the use of a buffer as shown in the circuit.

The most suitable tube is one of low μ and low resistance while its anode load is a pure resistance of 1,000-2,000 ohms. Measurement of such a stage at 10^8 cycles per second showed that with 120 volts applied to the anode circuit, an output of a hundred volts or so can be obtained without appreciable curvature of the amplification characteristic.

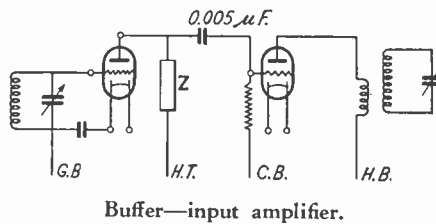

In the 200 kc. range, this system gives high amplification—up to 300 or more—and the input shunt resistance of the buffer tube is also very high.

Simplifying Dynamic Tube Curves

By R. C. HITCHCOCK
Meter Eng. Dept., Westinghouse
E. & M. Co., Newark, N. J.

DYNAMIC TUBE CURVES are seldom as clearly understood as they should be.

Technical books quite rightly show "static" curves, because any number of particular "dynamics" can be drawn in to suit some special case. It is the pur-

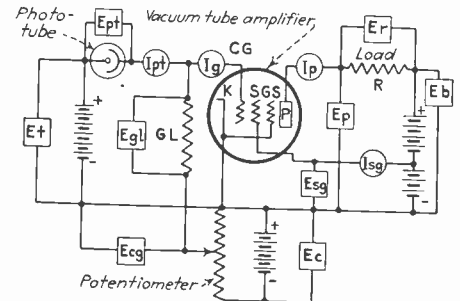

Fig. 1—Phototube amplifier circuit.

pose of this paper to show in detail how dynamic curves are drawn, with the aid of an additional voltage abscissa which simplifies the conception.

The circuit being considered is that of a typical direct coupled phototube-amplifier, (see Fig. 1) operated from batteries. Nine voltmeters and four ammeters are shown to facilitate description.

Dynamic curve for amplifier tube

The volt-ampere relation of a tube is best shown graphically. The family of plate current curves is shown by solid lines, as a function of plate voltage and several control grid voltages, in Fig. 2. These curves are known as "static" plate voltage-current curves, as they are obtained with no load resistance ($R = 0$). The next step is to determine the "dynamic" curves with a load resistor R in the plate circuit. This is done graphically. Assuming that E_b is 180 volts, load lines for various resistors R are shown on Fig. 2 by dotted lines. The lower scale of abscissas shows volts on the tube plate E_p increasing from 0 at the left to 180 at the right. The upper scale of abscissas shows volts on the resistor E_r , decreasing from 180 on the left to 0 on the right. Thus the 180 volts of E_b is always divided between E_r and E_p in proportion to their resistances. The load resistance R remains fixed, but the tube resistance varies with the control grid voltage. Note that the upper voltage scale simplifies the conception of voltage drop across the load, but it is important to remember that any one scale is correct for only one value of E_b . In the figure E_b is 180 volts.

The dotted load line for a 2,000 ohm R value will be determined, as an example. The maximum ordinate is 60 milliamperes, which for 2,000 ohms indicates that $E_r = 0.060 \times 2,000$

TUBES AND CIRCUITS + +

= 120 volts. Hence, the 2,000 ohm load line is a dotted straight line from 120 volts (upper scale) and 60 milliamperes to 0 volts (upper scale) and 0 milliamperes. In a similar manner, the load lines for 3,000, 4,500, and 6,000 ohms are dotted in. The plate dissipation $E_p \times I_p = 2$ watts is shown by a

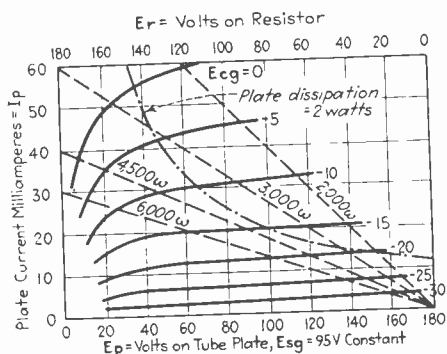

Fig. 2—Pentode curves.

dot and dash line. Values below this are advisable to minimize grid current.

Suppose that an arbitrary value of 15 volts control grid swing is assumed to be available. This requires a certain phototube circuit calculation which is given later. Referring to Fig. 2, the

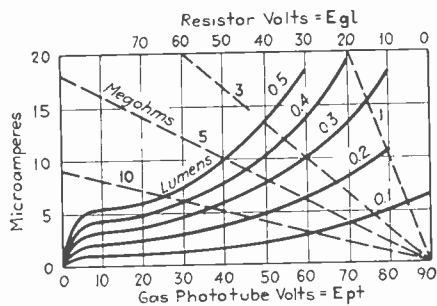

Fig. 3—Phototube curves.

4,500 and 6,000 ohm load lines are below the plate dissipation line for $E_{cg} = -5$ and so -5 to -20 can be used.

Usually the gridleak GL is chosen to have as high a value as is possible, in order to work on the minimum amount of light. However, the upper value of GL is definitely determined by the grid current under operating conditions. For example, using a 15 volt grid swing it would be desirable to have a maximum of 0.5 volt fluctuation due to grid current. This means that the E_{gl} voltage (with the phototube open circuited) should be less than 0.5 volt = $I_g \times GL$. If the I_g is 0.1 microampere, then GL should be less than $0.5/0.1$ or 5 megohms.

A gridleak of a value determined as above is applied directly in the phototube circuit. In general, the I_g or control grid current is smaller than I_{pt} , the

phototube current, as shown by Fig. 3, and comparing with the typical 0.1 microampere above. The problem, then, is to obtain 15 volts swing on E_{gl} , which is the voltage across the gridleak GL. The two voltmeters E_{pt} and E_{gl} must have such exceptionally low current drain (10^{-8} ampere) that they are impractical except for reference in the analysis.

The curves of Fig. 3 are of a gas filled phototube, the "static" curves being full lines. The solid "static" curves are drawn for each 0.1 lumen step down to 0.1 lumen. The design of projection optical systems, to provide the lumens needed, is beyond the scope of this paper.

The dynamic curves are plotted in dotted lines for 1, 3, 5, and 10 megohms by a method similar to that used in the plate circuit curves. The upper abscissa shows resistor volts E_{gl} decreasing from left to right.

The requirement, assumed as previously, is for 15 volts across the gridleak, which can be as much as 5 megohms. Running down from 15 volts on the E_{gl} upper scale of Fig. 3 to the 5 megohm dotted line, shows that I_{pt} is 3.0 microamperes and that less than 0.1 lumen of light is required.

+

Electronic photometer

WHEN THE ROUTINE ANALYST views a long row of beakers containing samples to be analyzed for the same ingredient, by color, he wishes for an Aladdin's lamp. Application of the modern method of using light-sensitive surfaces seems to be the genie the chemist looks for. Central Scientific Company has developed a photo-electric photometer based on the laws of light transmission of substances formulated by Lambert and Beer.

According to this law, when the light rays from a constant source of illumination are passed through a solution of a substance and a light filter with transmission characteristics corresponding closely to the absorption characteristics of the solution, the intensity of the transmitted beam of light is proportional to the concentration of the substance in solution. Mathematically, the concentration is proportional to the negative logarithm of the transmitted light intensity. The logarithmic function does not complicate the calibration of the instrument, as semi-logarithmic co-ordinate paper is used to plot the relation of scale readings to known concentrations of the substance sought. By this method only a few calibration points need be determined and the approximately straight line joining them

will form the calibration curve. When the photometer is once calibrated for a substance, the unknown sample is placed in the glass cell, inserted in the light path and the scale reading taken from the micro-ammeter that indicates the intensity of the light transmitted. The concentration in grams per 100 cc is obtained through reference to the calibration chart.

The essentials of the instrument are: a steady source of illumination, a diaphragm for adjustment of the light intensity to bring the meter reading to the same initial reading, a glass absorption cell to hold the unknown solution, a light filter to transmit only the light rays in the absorption band of the substance, and a light intensity measuring device. In the photometer, a Weston photronic cell, and a sensitive micro-ammeter for indicating the value of the current generated, make up the light intensity measuring device.

To eliminate difficulties due to line voltage variations, affecting the intensity and spectral characteristic of the illumination, a special transformer supplies 6.5 amperes at 6.1 volts to the lamp and maintains the illumination constant to within 1 to 2 per cent.

The instrument was developed by Drs. Sheard and Sanford of the Mayo Clinic and Mayo Foundation to determine rapidly the grams of hemoglobin per cc. in blood samples.

+

IONIC LAYER MODULATES MICRO-WAVES



Dr. Irving Wolff demonstrates the artificial Heaviside layer (ionic tube shown at left of reflector) which modulates the four-inch waves produced by the transmitter.

electronics

McGraw-Hill Publishing Company, Inc.
330 West 42d Street
New York City

O. H. CALDWELL, *Editor*

Volume VII

—JULY, 1934—

Number 7



Credit radio engineers

FOR three years the radio industry has appreciated, subconsciously perhaps, the quiet work of the RMA Standards Section under the Chairmanship of Virgil Graham from Stromberg-Carlson. Many problems affecting the engineering or manufacturing portions of the industry have been solved, often before individual manufacturers realized the problem existed.

Much of this work has been carried out on time that belonged to the members personally and not to the companies they represented; time in which they would rather be doing something else. Much of it is dull work, repaying the members only by providing opportunity for association with other engineers.

In an industry, dependent for progress solely upon its technicians, the labors of this Section should be more openly and vocally appreciated. The changing membership deserves commendation, especially Chairman Graham, who has given much of his time and energy to all of the technical committees making up the Standards Section.

In all RMA there is no more worth-while work being done.



It's now up to the FCC

BEFORE being finally enacted by both houses of Congress, the new radio law of 1934 was purged of most of its objectionable features, and the radio industry for the time being can breathe more easily.

The new commission of seven members took office July first, assuming supervision over radio,

telephone and telegraph services where these are interstate in character. The new Federal Communications Commission adds to its functions appraisal and rate-making, which were entirely outside the purely traffic-control activities of the former Radio Commission.

Departure from the spirit of the unfortunate Davis Amendment (which limited radio facilities to population quotas, regardless of the physical possibilities for radio service), is seen in an admirable clause of the new act permitting new 100-watt broadcast stations where desirable, without respect to state quotas.

The sinister proposal to turn over 15 to 25 per cent of the wavelengths to "non-profit" broadcast organizations, appears in the new act only to the extent that the FCC is instructed to "study the proposal" that Congress legislate definite percentages to educational, religious, fraternal and labor organizations.

Apparently there will be little change in the actual operation of the new law itself. How it actually works out, and how the radio industry is affected will depend most of all upon the personalities and capacities of the Commissioners appointed.



To consign—or not consign

A SUBSTANTIAL proportion of radio-tube replacements are now going out to the trade on the consignment plan, giving a wider opportunity for observation of consignment selling in every-day operation.

Considerable difference of opinion has already developed as to the advantage of consignment selling compared with outright sales.

The smaller dealers seem to like this elimination of their own investment in tube stocks. Some of them even ingeniously carry their slow-moving items on consignment, while buying the rapid-selling numbers for cash, at better prices.

On the other hand, the jobbers complain of the elaborate paper-work required by the consignment plan, and of the expensive time taken by their salesmen to check dealers' stocks, in addition to the reduced wholesale profit.

Electronics holds no brief for either consignment selling or outright sales. We are looking for all possible evidence relating to any plan which will make for the best trade conditions,

hold up prices to sound levels, and keep a healthy prosperous industry.

So far as consignment and outright sales are concerned, there is still, as Sir Roger de Coverley put it: "Much to be said on both sides!"



Fifty years an electrical publisher

JAMES H. McGRAW, whose publishing zeal and tireless interest in electrification have been the inspiration back of *Electronics*, *Electrical World*, and other associated electrical publications since their beginnings, last month celebrated his fiftieth anniversary in publishing. As chairman of the board of the McGraw-Hill Publishing Company, Inc., Mr. McGraw is still actively at work at 73 years of age, and is intensely interested in the new fields envisioned by *Electronics*.

Mr. McGraw came to New York City from Chautauqua County, N. Y., in 1884, a country schoolmaster, and shortly began to publish a horse-car paper, which with prophetic vision he soon converted into the *Electric Railway Journal*, years ahead of the electrification of the industry. Spreading into other industrial fields, but always with the electrical publications as the nucleus of his life work, Mr. McGraw built up the McGraw-Hill company which now publishes 25 industrial, business and engineering papers.

Speaking to his publishing associates on his anniversary, with the background of his half century of close contact with American industry, Mr. McGraw expressed strong confidence that this Fall will see a returning flow of private capital into industry and business, and distinct improvement in general conditions.



Defining "high fidelity" —a 5-decibel limit

Editor *ELECTRONICS*:

Permit me to commend the attitude of *ELECTRONICS* on high-fidelity broadcast reception, a subject in which I have been actively interested for several years. Your strong editorial support should materially aid this important cause. As you have pointed out in your May editorial, it is par-

ticularly important for the technical people to arrive as soon as possible at a definite understanding as to what we mean by "high-fidelity," in order to discourage the almost inevitable wholesale abuse of the term.

I was very much interested in your quotation of the tentative definition of a high-fidelity receiver, issued by the RMA Engineering Division, in which the total variation in acoustical output is limited to 10 decibels. With regard to this definition I am of the opinion, based on several years' experience in the development of high-fidelity receivers, that a 10-decibel variation is entirely too liberal for a real high-fidelity receiver. Permit me to call your attention to a paper on this subject, which I presented at the New York meeting of the Institute of Radio Engineers last November, in which I outlined my views and proposed a definition for a high-fidelity receiver (see *I.R.E. Proceedings*, May, 1934, page 567) in which the variation of response was limited to 5 decibels. Since we have been able to limit the total variation to 3 decibels without excessive increase in cost I considered even this 5 decibels a liberal allowance. It is by no means an irksome requirement.

It cannot be too strongly emphasized that uniformity of response is fully as important as extension of frequency range. If the term "high-fidelity" is to mean anything the predicated performance should be kept at a reasonably high level. Compromises at this stage will only encourage slovenly engineering and the chiselers, and lead to trouble later.

STUART BALLANTINE

Boonton Research Corporation
Boonton, N. J.



RADIO-ACTIVE NITROGEN PRODUCED BY DEUTON BOMBARDMENT



Dr. Charles C. Lauritsen of Caltech, shown with his associates Richard Crane and W. W. Harper, has succeeded in producing a new isotope of nitrogen having highly radio active properties by bombarding carbon with deutons, or "heavy-water" nuclei. The apparatus shown is the first to produce a radio-active substance by a purely artificial technique.



BOOKS



FOR ENGINEERS USING ELECTRON TUBES

Signals and speech in electrical communication

By John Mills, Bell Telephone Laboratories. Author of "Within the Atom" and "Letters of a Radio Engineer to His Son." Harcourt, Brace & Company, New York. (281 pages. 1934. Price \$2.)

BOTH THE ENGINEER and the lay reader will find this book interesting and instructive. It sets forth in delightfully lucid and clear terms, the basic theory of modern communication, telephony, radio, facsimile, television, and sound reproduction, but its charm and interest lie particularly in the light of new aspects and new relationships which the author throws on familiar phenomena.

Thus the fundamental distinction between a conductor and an insulator is graphically put in words like these:

"Mobility on the part of its electrons is the difference between a conducting and an insulating material. In those substances like glass or rubber, where all the electrons are stay-at-homes who keep closely in the family circles of their atoms, conduction is impracticable. In the metals like copper, there are always innumerable wandering electrons which stray from their atomic homes. At times one may pause, to substitute in the electronic group around an atomic nucleus, for another wanderer; at that moment that particular atom has a normal constitution. There is an undirected haphazard motion—an exhibition of the lowest form of energy.

"Except that all electrons are indistinguishable they behave like unrestrained children at a large picnic, dashing back and forth between the less mobile groups of adults. In their motion they will generally dodge the more stable groups or swing through and past them; but frequently in such a manner as to cause them to shift slightly in position. If the electrons are excited to more violent motion the whole material is correspondingly wrought up. It gets hotter. The heat which it contains is inherent in the motions of all its particles. The rapidity with which the metals conduct heat is due to the mobility of their electrons, which serve to spread throughout the whole body disturbances which would otherwise be localized.

"When a current of electricity flows

through a wire there is superimposed upon the accidental motion of the electrons an additional and directed motion. The electrons while persisting in individual vagaries can drift under the influence of an electric generator, like gnats in a swarm that shifts before a breeze. . . .

"The reaction is due to the difficulty of driving the electrons through the wire, for each must dodge and jostle its way along, like a football player running through a scattered field of opponents. All the particles of the wire are set into more violent motion and the increased violence is manifested by a higher temperature."

Die lichtempfindliche zelle als technisches steuer organ

(Photocells and light-sensitive control in industry). By H. Geffcken, H. Richter and J. Winkelmann. Deutsch-literarisches Institut J. Schneider. Berlin-Tempelhof. Price 23 marks. Pp. 300; 300 figures; 4 tables.

THE BOOK IS DIVIDED INTO three nearly equal sections, the first one dealing with the physics of the photocell, the barrier plane, resistance and thermocouple cell, with well balanced summaries at the end of each chapter; the second part with the simple circuits and relays by means of which the photocells exert their control, and the remainder of the book presenting the practical applications in industry. To bring order into the vast field in which the electric eye serves a useful purpose, the authors distinguish five functions: the light relay proper, responding to the presence or absence of light, the sentinel device, counting and protecting with the aid of long stationary beams of light, the threshold relay entering into action above or below certain levels of illumination, the measuring instrument, and finally the exploring circuit in which a rapidly moving and variable beam falls upon the cell.

Among interesting applications are a machine which packs articles into boxes so that the printed label on each piece faces upwards (p. 219), photoelectric control of trains (p. 227) on the German National Railway, and attempts (p. 268) to develop the weaving machines first described by Korn in *Electronics* for October, 1930. Geffcken and Richter themselves have announced in 1926

one of the first grid tubes and the pages dealing with this kind of grid-controlled discharge tube are of particular value. They call such tubes glow relays when the cathode is cold, and iontron (in place of thyatron) when the cathode can be heated.

While there are practically no applications not previously described in *Electronics*, the many circuits shown, and the rich experience of the authors appearing in and between the lines (see also *Electronics* for February 1933, p. 48) should make the book a valuable guide in the choice of the correct equipment to be purchased in a given case.

Industrial electronic Tubes

Westinghouse Extension Course No. 25, Industrial Relations Department, Westinghouse Electrical & Manufacturing Company, East Pittsburgh, Pa. 216 multigraphed pages. Price \$2.25.)

WHILE PRIMARILY prepared for the use of Westinghouse men, copies are also made available at the same price to outsiders interested.

Arranged in a series of "assignments," the lessons are in the form of a practical treatise which will be of interest to those concerned with the many aspects of tube development and use.

Covering a wide range of fundamentals, the course deals with the electronic tube as it has been developed and applied to industry. The make-up, characteristics, and performance of the various types are treated, together with a number of typical applications illustrative of the important part they are already playing in providing new or better ways of doing things.

Introductory acoustics

By G. W. Stewart, Ph.D., Sc.D., D. Van Nostrand Co., Inc., New York. 200 pages, price \$2.75.

This is a text primarily intended for students who have had no previous preparation in physics. Mathematical treatment is necessarily almost completely eliminated except for a few indispensable formulae. The book is excellent for giving a broad and under-

standable knowledge of elementary acoustics, although careful reading is necessary to make up for the lack of mathematics.

The mechanics of simple waves is first treated in general, the author gradually working up to the particular properties of sound waves in gases, and other media. Reflection and absorption in auditoriums and rooms is then treated in a concise manner, and reverberation and echo effects are made very clear. The properties of acoustic materials are discussed and tables of absorption coefficients are given.

Chapter III goes into the details of interference, and an explanation of the behavior of various kinds of reflectors due to this effect. Here, as in other chapters, Professor Stewart describes experiments he has conducted that illustrate the phenomena clearly. Under Refraction and Diffraction explanations of effects often observed in nature, and of some not so common, are disclosed in an interesting manner. The analyses the author gives cannot fail to be grasped by any student anxious to understand acoustics.

Reflection and phase effects are carefully explained, and the physics of sound waves in pipes is then dealt with. Change of area, open and closed end reflection, absorption in conduits, etc., make the chapter not only interesting but very valuable. An equally good chapter treats the phenomena of resonances. These include the various practical kinds continually met with such as in open and closed pipes, conical and other horns, in musical instruments, buildings, etc.

Musical sounds, sounds of speech, and binaural effects are briefly dealt with, while the author handles audibility quite at length. Acoustic transmission in various media is explained, including valuable material on theory of conduits and acoustic filters. The fundamentals of music are clearly set forth in a chapter part of which was prepared by Dr. P. A. Clapp. Finally, the production of sound by musical instruments, the voice, and other sources is covered, with a brief description of loudspeakers as a conclusion.

This author's method of summing up the gist of each chapter in a set of questions to be answered by the student, almost amounts to a guarantee of a thorough knowledge of the fundamentals of acoustics, if the questions can be answered correctly.

The only subject which it is thought could have been dealt with in more detail very profitably is that of loud speakers and microphones. These have been almost totally neglected—certainly exponential horns should have been dealt with in the same detail as other effects. Mention of the principles of some of the instruments used in fundamental measurements, such as the Rayleigh disc and the thermophone, would also seem to be of importance.

Earth, radio and the stars

By Dr. Harlan True Stetson, former director Perkins Observatory, now research associate in geophysics at Harvard University. McGraw-Hill Book Company, New York. (309 pages, 1934, price \$3.)

DR. STETSON'S long researches on the behavior of radio reception as influenced by the sun, the moon, and the outbreak of sun-spots, have already resulted in his being widely recognized as an authority on the subject. Radio engineers have often been of the opinion that radio behaves less satisfactorily at the time of full moon. Dr. Stetson publishes curves based on his own observations which appear to indicate that it is not the illumination of the moon but its position in the sky that is responsible to a surprising degree for the performance of radio reception. On the basis of these observations he believes that electronic tides in the so-called ionized layer of the earth's atmosphere are caused by the moon. These tides assist or interfere with the navigation of radio

waves in the mysterious ocean of the atmosphere, very much as the ocean tides, also caused by the moon, affect the navigation of the high seas in the well known manner.

With astounding boldness Dr. Stetson intermarries the sciences of astronomy, geology, physics, and radio engineering. Even the science of biology appears as an important witness to the wedding, for the author recapitulates the available evidence that the solar cycle has been recorded in the growth of trees through the centuries, and may well be reflected in the varying population of the fur-bearing animals. In a speculative mood he raises the question of the possible effects of the solar cycle upon the varying output of the ultra-violet rays which may produce profound physiological changes in one's glands and metabolism, to which one's moods and temperament are known to be susceptible.

Cosmic rays, the possibilities of unknown electronic emissions from the sun and stars in producing strange illuminations in the night sky, and Carl Jansky's curious radio static which points to a sidereal origin, also come in for discussion.

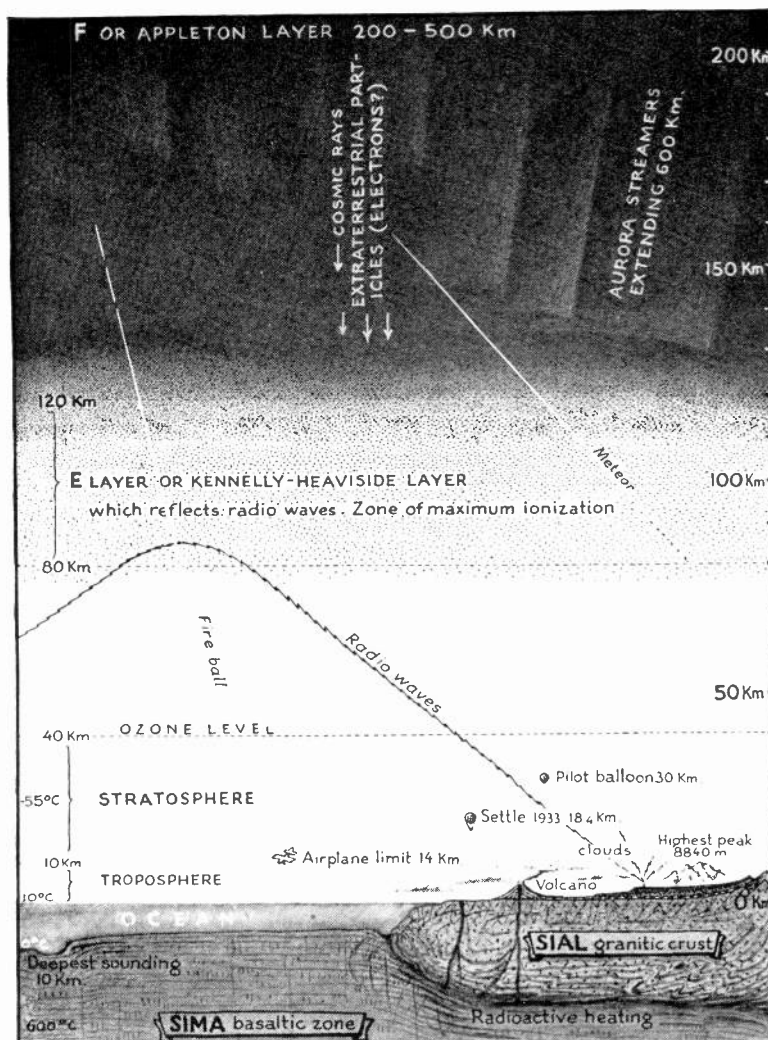

Cross-section of earth's crust and the atmosphere, from Dr. H. T. Stetson's "Earth, Radio and the Stars."

Electronic music from vibrating reeds

By ROBERT G. SILBAR

AN ELECTRONIC PIANO, which has neither strings nor sounding board, and which is said to produce tones 90 per cent fundamental, has gone into active production in a Kalamazoo, Mich., factory, to sell for less than \$400. The new instrument, called a "clavier," has short reeds or slivers of steel tuned to the piano scale, instead of lengths of wires. Vibrations of these reeds are picked up by magnetic induction and reproduced in an amplifier unit.

The thin strips of steel which produce the tones are tuned by length and weight. Fastened at one end and under no tension, they are said to stay in tune permanently. A simplified plucking action sets these "strings" vibrating.

In other electronic pianos pick-up units have been attached to sounding boards or bridges, with the result, it is explained, that a foreign frequency—the natural period of the sounding board itself—is mixed with the pure string tone. By eliminating the sounding board the new clavier eliminates the foreign frequency source.

One side of the magnetic circuit includes the vibrating reeds of steel. The other side is a magnetic pole with permanent magnets providing the flux. An air gap between the steel reeds and the poles can be varied, enabling by simple adjustments the effect of a matched impedance, or a leveling of the intensity of the tones. This means that high and low notes have the same loudness as all other notes. In a standard piano or other sounding board instrument, a drop-off in power is noticeable in the extreme registers.

In sounding-board instruments the acoustic impedance between string vibrations and the sounding board itself cannot be matched. The new clavier matches such impedance between "strings" and the magneto-electric unit, utilizing as a tone pattern all string energy developed. By amplifying this pattern a musical tone of as much volume as desired is possible.

Magnetic-flux variation is utilized to generate current. When one of the steel reeds is plucked, a flow of electricity is set up in an associated coil—an electrical copy of the string vibration pattern. The "string" is mechanically designed so that it vibrates appreciably longer than the corresponding string on a standard piano. The efficiency of the

magnetic circuit depends on the amount of variation in the flux flow rather than strength of magnetism. The amount of magnetism (number of lines of force in the magnetic field) necessary is very small.

The tone produced is of percussion character. However, the player through a pedal control—a potentiometer on the pick-up circuit—can eliminate the impact or percussion at the instant the tone begins and so produce a tone of organ character.

A variation in construction, with the tuned slivers of steel clamped in the middle instead of the ends, enables other musical effects. When the free end is plucked the other end vibrates, the method of mounting permitting the vibrations to pass through from one end to the other. By including only the unplucked end in the magnetic circuit a smooth organ-like tone results. By including both ends some percussion character is added. By having the plucked end slightly out of tune with the free end and including only the unplucked end in the magnetic circuit a vibrato of any desired frequency is produced. It is also possible to arrange the

pole ends so the string frequency is doubled in the magnetic field and a tone an octave higher than the string frequency produced. The vibrato effect is controlled by damping at will.

The plucking action differs from the harpsichord action by giving touch control over tonal dynamics. The action has only six parts to the piano's 95 to produce one tone.

The reproducer unit is in a separate case from the keyboard and may be placed at a distance from the clavier, enabling the player himself to hear as others do, all tones coming from the loudspeaker unit. Best advantage of acoustical conditions in a room can be obtained thus, also. Seven tubes are used in a standard circuit, with an output up to 30 watts. A Jensen loudspeaker is incorporated in the set. The potentiometer on the foot pedal of the clavier makes it possible to produce volumes ranging from zero to 30 watts. A piano at best has a peak power of approximately two watts, measured electrically.

Because of absence of high overtones, the clavier notes "blend" with other instruments to a greater extent than the piano. By means of earphones it is possible to practice on the clavier without disturbing other persons in the room. For piano schools a circuit has been devised whereby 50 of the instruments can be played in the same room, with the instructor able to tune in on any one instrument.

The keyboard and reproduction unit together weigh only 150 pounds. The keyboard unit is extremely compact, the entire mechanism being confined to a space 27 by 48 inches. Prof. Lloyd Loar, acoustical-engineer, developed the clavier.

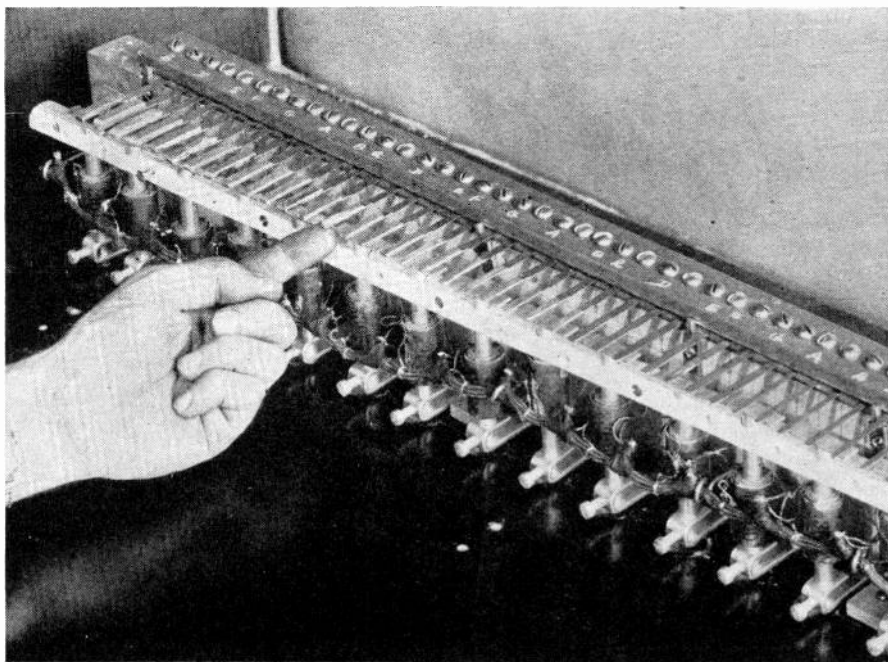

The row of tuned steel reeds, vibration of which sets up oscillatory currents which are then amplified to produce an output of 30 acoustic watts

REVIEW OF ELECTRONIC LITERATURE

HERE AND ABROAD

Quick heater tubes in Germany

A method of reducing the heating time of a.c. tubes used in home receiving sets has been devised by a German engineer. Tubes in that country ordinarily run at 4 volts across the filament terminals. This engineer operates the tubes at 7 volts when the set is first turned on, and when the plate current comes up, indicating the cathode has been brought to normal temperature, the voltage is automatically reduced to the proper value.

Heating time is reduced from 34 seconds to 8 seconds in this manner.

Ryall-Sullivan high precision heterodyne oscillator

[W. H. F. GRIFFITHS] By detuning one of the condensers in the band pass filter it is possible to compensate for the high frequency losses due to leakage, so that the output voltage is constant to within 0.05 decibel of the low frequency voltage up to 10,000 per sec. Instead of resorting to piezo crystal stabilization, inductances and fixed mica condensers which do not change with temperature are used. Their use allows the oscillator to hold its calibration for one year to within less than $\frac{3}{4}$ per cent instead of 2 per cent for good commercial beat-frequency oscillators.—*The Wireless Engineer* 11: 234-244, 1934.

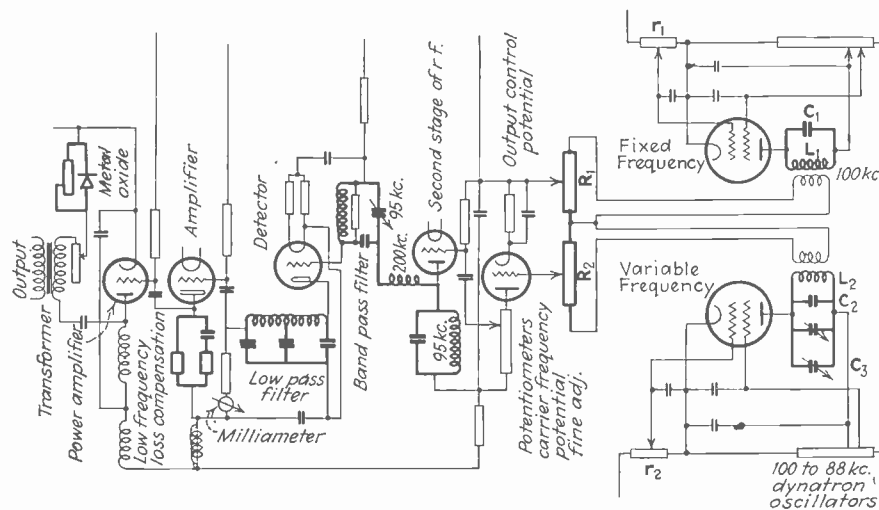

The extremely stable operation of this heterodyne oscillator results from detuning the band-pass filter.

Electronic method for testing watches

[R. TAMM, Siemens Laboratory, Berlin.] A difference of one second per day between two watches means a difference of not quite $1/1,000$ sec. per minute and a difference of one minute a little more than $4/100$ sec., or much less than the time between two ticks of the watch ($\frac{1}{2}$ sec.) and difficult to establish by direct observation if only a few minutes are allowed. By letting the tick of the watch to be tested act upon a microphone, conducting the sound over a short rod, and by amplifying it, the voltage which it sets up causes the current to flow in a gas-filled triode. A short time afterwards the

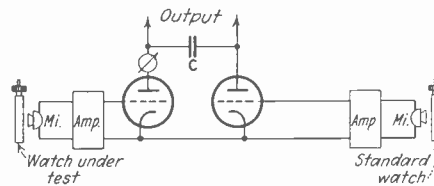

Quick and accurate regulation of watches is made possible by the use of two microphones.

tick of the standard watch releases in the same way a second tube, the voltage wave from the condenser connecting the plates of the two tubes stopping at the same time the current in the first tube. At the next tick the current flows once more through the first tube and through the meter until the tick from the standard arrives. If both watches keep the same time, the average current re-

mains constant, but if the first clock is fast, the current tends to increase with each tick. It is possible to calibrate the meter in terms of milliseconds and to complete the test within a few minutes. As the sound is not a single pulse, the last stage of the amplifier is given a high negative bias so that only the peak of the tick is allowed to impress the tubes.—*Z.V.D. Ing.* 78 (18): 556-558, May, 1934.

Reliability of selenium barrier-plane cells

[L. BERGMANN, University of Breslau.] The part played by the electrons in barrier plane and in vacuum cells is to a certain extent the same, and when highest sensitivity is not aimed at in their preparation, they are as reliable as the vacuum type. Two cells of recent manufacture were given for seven days an illumination of 600 foot-candles, one cell being short-circuited, while current was drawn from the second cell only during the time necessary for the daily test. The current in the short-circuited cell remained at $380 \mu\text{A}$. (sensitive surface 2.8 sq.cm.), while the current given by the open cell decreased slightly from the third day on, falling from 390 to $370 \mu\text{A}$. on the seventh day. Older cells of the more sensitive type, on the other hand, show distinct aging, and a drop from $1,400 \mu\text{A}$. on the first day (500 foot-candles, sensitive surface 9.7 sq.cm.) to $80 \mu\text{A}$. at the end of the third day. When such cells are tested at 10 foot-candles (the illumination recommended for offices) they remain as constant as the more recent type of cells.—*Phys. Zeits.* 35: 450-452, June, 1934.

Measurement of small displacements

[W. FRICKE, University of Jena.] By means of radio circuits it is possible to detect changes in capacity of the order of one-millionth, and to measure displacements of the order of 10^{-9} cm., smaller than the diameter of an atom, the limit being set by the shot effect rather than by the strength of the current. The change in capacity makes

itself felt in the slope of the resonance curve of an oscillating circuit, or in the plate current of an oscillating tube. But a particularly simple method is to use the natural capacity, a few $\mu\mu\text{f}$ between grid and plate, as the only means of sustaining oscillations in the tube, grid and plate circuits being tuned to nearly the same frequency (wave-length 84.88 m., and 83.44 m.). The frequency of oscillation of the tube (85.69 m.) depends on the constants of both circuits. Os-

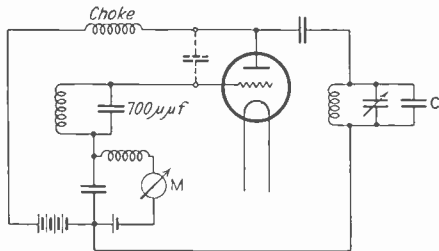

Resonant circuit for measuring capacity changes resulting from minute displacements between plates.

illations in such a circuit are only possible in a narrow range of frequencies, and a small change in the plate condenser produces a large change in the amplitude of the a.c. and the strength of the grid current. The operating point giving highest sensitivity is near the point where the oscillations are just setting in. With an ordinary tube it is possible to determine two millionths of one centimeter and to obtain a straight line relation between displacement and grid current. The device is being used for controlling the thickness of paper during manufacture.—*H. f. Techn. El. ak.* 43: 149-151, May, 1934.

The mixing hexode at audio frequencies

[J. KAMMERLOHER, Berlin.] The mixing hexode eliminates the coupling which exists in ordinary tubes with several grids between the receiving circuit acting upon the first grid and

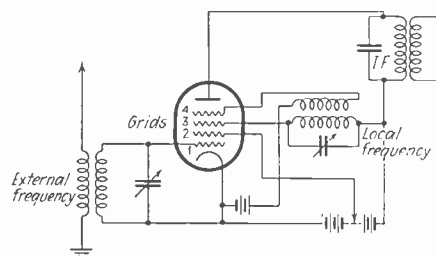

Mixing hexode connected for use at audio frequencies.

the oscillating circuit which generates the second frequency. In the hexode the second grid is given a positive potential and is used as a screen grid. The third grid acts as a plate and cathode at the same time, the rest of the tube as an

amplifier. The study of the plate current as a function of the voltage applied to the first and fourth grid shows that the a-c current in the plate circuit of the tube consists of three components, one component having a frequency equal to the sum of incoming and local frequency, the second half this sum, and the third equal to the difference. The amplitudes of these components depend respectively upon G_1V_4 , G_1V_1 and $V_1V_4 dG_1/dV_1$, where G is the mutual conductance and V the voltage of the grid indicated by the number. Only the lowest or difference frequency is made use of, the ratio of output to input amplitude being given by $RV_1 dG_1/2dV_4$. The theory is confirmed by experiments in which the incoming frequency is equal to 700 cycles and the local frequency equal to 900 cycles per sec.—*H. f. Techn. El. ak.* 43: 161-165, May, 1934.

Electrodynamic metal-foil loudspeaker efficiency

[H. NEUMANN and K. WARMUTH, Siemens Research Laboratory.] In the metal-foil loudspeaker the entire vibrating surface, not only a coil attached to the summit of the cone is traversed by the a.f. current. The magnetic field, about 1,000 gauss, is produced by eight flat and narrow coils (with 180 turns of copper ribbon each), stacked one above the other with 5 cm. distance between them. The aluminum foil used, about 40 sq.in. in area and 5/1,000 to 5/6 mm. thick, is held in place on the two sides by strips of copper and moves in the field inside the coils. The foil is corrugated, the ridges being parallel to the magnetic field to insure greater stiffness in the direction of the lines of force. One-half of the foil is of heavier material than the other, so that a wider frequency can be rendered. The quality of reproduction is better than that obtained from cone loudspeakers, but the efficiency obtained, 5 to 10%, is too small in view of the energy absorbed by the field coils, to make this speaker a serious rival of the cone loudspeaker, at the present time.—*El. Nachr. T.* 11: 178-187, May, 1934.

Old and new circuits for the binode detector

[H. PITSCHE] The binode (see these digests, Jan. 1933), that is the combination in the same bulb of a diode having a screened ring-shaped plate surrounding part of the cathode with a triode or screen grid tube, both using the same source of electrons, allows undistorted detection of strong signals and gives a

better separation of r.f. and a.f. currents. Parallel or series arrangement may be used. When the resistance R is placed in parallel to the tuned circuit, no d.c.

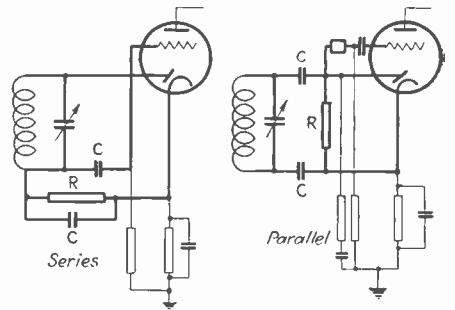

Alternative circuits for use with the binode detector.

or a.f. penetrates into the tuning coil and the plate current of the r.f. stage which precedes it may directly be led into the coil or into part of it. In the series arrangement, the coil is traversed by the three components of the rectified current. The a.f. voltage across R may be amplified, the d.c. component, easily separated by means of a condenser, used for a.v.c. A more complete separation of a.f. and r.f. is obtained when a choke is placed in series with the resistance R . Provided that the r.f. by-pass condenser C is small, there is less damping than in the parallel circuit, because the internal path of the diode and R are shunting the tuned circuit. The disadvantage is that the rotor of the condenser, being at the a.f. voltage, cannot be grounded.—*Punkt. Mon.* 137-140, April, 1934.

COMBATS WINDOW THIEF

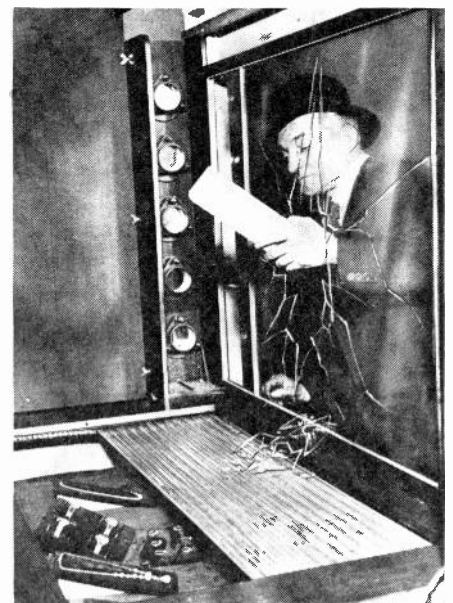

Following a series of "smash and grab" thefts in London jewelry stores, this photo-cell guard has been developed, which instantly draws a horizontal steel shutter over the valuables on display.

Note on Fernsehen und Tonfilm

SINCE January, 1933, *Fernsehen und Tonfilm* appears every other month as a supplement to *Funktechnische Monatshefte*, Weidmannsche Buchhdlg., Berlin. Volume and pages are separately numbered and it continues to be the official organ of the German Television Society. The most recent issue is April, 1934, Number 2, Volume 5. The editors are the same as before (Dr. F. Banneitz and Prof. Dr. G. Leithauser).

Screened Coil Inductance

[M. J. O. STRUTT, Philips' Research Laboratory, Eindhoven] When a coil having a radius a is wound with N turns per cm. over a height $2b$ cm. and is placed in the center of a cylindrical box of radius A and height $2B$, with flat covers at top and bottom, the wave equation may be replaced by the Laplace equation of the potential for all wave-lengths in air decidedly larger than B . Near the metallic screen the magnetic lines of force are approximately parallel to the walls. The theory

leads for the inductance L in henrys of a single layer coil to a sum of a few terms of the following form: $0.2 \times 10^9 \pi^2 N^2 (A \sinh(2ka/A) - 2kb) a^2 J_0^2(ka/A) b^2 k^3 J_1^2(k)$, where in the first term k is the first root, 2.405, of the Bessel function J_0 ; the second root, 5.52, in the second term of the sum, 8.654 and 11.79 in the following terms. Three or four terms suffice in general to give the inductance to within 1 per cent. Numerical results will be presented elsewhere.—*H. F. Techn. El. Ak. 43: 121-123, April, 1934.*

Mixing hexodes for the beat-frequency oscillator

[V. BAR AND TH. SCHULTES, Heinrich Hertz Institute, Berlin] The hexode is equivalent to two triodes placed in series, the space between the first plate, in the form of a screen grid, and the third, negatively charged, grid acting as the cathode for the second unit. When the fourth or last grid is strongly negative, all the electrons are collected by the first plate; but as its potential is made more positive, more electrons are drawn to the second unit and the current to the first plate shows a falling

characteristic enabling the tube to oscillate. If at the same time an oscillating voltage of about the same frequency is applied to the first grid from an outside source, a modulated wave consisting of r.f., sum and difference frequencies is obtained in the plate circuit, the low and the high frequencies being easily separated by filters without a detector.

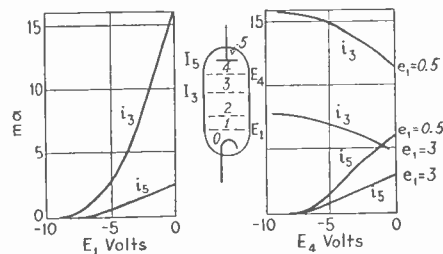

The drawback is that the second oscillating circuit is under the direct influence of the first circuit so that the distortion of the a.f. wave increases at low frequencies unless the amplitude of the outside wave is kept small. More power is obtained by using two separate tubes as r.f. oscillators applying the voltages to the first and fourth grid of the hexode. With 1.5 volt r.m.s. at each grid, the hexode gives about 2.5 volts across a 10,000 ohm load.—*El. Nachr. Tech. 11:110-114, March, 1934.*

Vacuum tube processes

[Continued from page 213]

being deposited on the tube walls. Barium, which is now quite commonly used, is rather expensive, and requires a much higher temperature to explode than does magnesium. It is much more active as a keeper, and will greatly decrease losses due to gassy tubes, where it is economically feasible to use it. The compromise is an alloy of barium and magnesium. On exploding this type, magnesium comes out first, and the barium later, if the heat is intense enough. Otherwise only magnesium is distilled out. The barium layer is on the inner surface of the magnesium, and has a very effective keeper action.

Aging the tube has stabilization of characteristics as its prime object. This is accomplished largely by gas absorption in the plate. The usual procedure consists in lighting the filament at a voltage that is about 25 per cent above normal, and applying a plate potential. This is always a safe treatment for all tubes, and will often bring a tube that is below the required limits up into the prescribed range. It also brings the filament up to full activity. In the tubes with larger filaments than the 71A, grid and plate may be connected together and made positive, or the grid alone may be made positive. This treatment removes any adherent dirt or gas from the grid if the latter is brought to red heat by means of a fairly heavy load.

In indirectly heated types, the grid treatment is absolutely necessary for proper functioning of the tube. Grids that are positively charged during operation, such as accelerator grids are best kept floating until toward the end of the aging schedule—at least until after the control grid has been thoroughly heated and cooled so that any oxygen or oxidizing gas may combine with a

grid that is negative during operation, and since no electron impact occurs on the negative grid during operation, no gas is liberated from an oxide surface upon it. Non-oxidizing gases can safely be absorbed in the plate, and to a lesser extent, in positive grids. The latter should be heated by internal bombardment, when connected to the plate, and on cooling, will absorb some gas, but will have a clean surface. The plate structure, because of its great surface, is the safest repository for residual gases, and the final aging operation should be aimed at placing as much as possible of the remaining gas into it. As before, with floating grids and positive plate, internal bombardment will heat the metal and open its pores, so that in cooling much of the residual gas is absorbed.

Iron in the more costly tubes

Editor, *Electronics*:

With respect to the statement on page 104 of April *Electronics*, that iron "is displacing nickel to a considerable extent in the cheaper tubes," I would like to call attention to the fact that Svea metal (Swedish iron) is also now being used in many of the more expensive types of tubes. This metal, which was applied at first in some of the more popular types of tubes—such as the 57 and 58—is now being used in a number of heavy-duty power rectifiers, some of which are very costly.

One type of mercury vapor rectifier using a cylindrical Svea-metal plate is listed at \$168, another lists at \$30 while a third sells for \$18.50.

The use of this metal in these types indicates, we think, its widening field of application and possibilities for heavy-duty work in some of the larger and more expensive types of tubes.

H. C. TODD.

Swedish Iron & Steel Corporation
New York City

+ NEW PRODUCTS

THE MANUFACTURERS OFFER

Compact suppressor unit

THE ERIE RESISTOR CORPORATION, Erie, Pa., has placed on the market a new suppressor resistor to reduce ignition interference on radio equipped automobiles. Known as type A-1, it takes up very little more installation space than an ordinary spark-plug nut, which it replaces. Overall dimensions are 29/32 in. in length and 29/64 in. in diameter.

This unusual compactness is made possible by the development of an extremely short resistance pin that is only 17/32 in. in length. In spite of its size,



the unit will not break down under the high voltages used in ignition systems.

Comparative tests and performance curves show that the new A-1 Suppressor is on a par with the larger types of Erie suppressors. Life tests operating under load of $\frac{1}{4}$ in. spark gap and at 300° F. show less than six per cent change in resistance after 250 hours.

The new suppressor has no soldered connections, thus eliminating danger of open circuiting due to engine heat or vibration. It can be supplied in any desired resistance up to 50,000 ohms.—*Electronics.*

Sensitive photo-relay

G-M LABORATORIES, INC., 1731 Belmont Avenue, Chicago, announce a new photoelectric relay capable of operating at greatly increased distances. This type of Relay will operate reliably on changes in illumination as small as one foot candle or less, and when used in conjunction with the G-M No. 1217 light source can be operated at distances as great as 90 feet with white light and up to 40 feet with infra-red-beam.

The No. 1217 Light Source can be furnished with a 6-volt lamp having a rated life of 3,000 hours, and uses a condensing lens with an adjustable focus lens tube. At 10 feet this light source provides an illumination of 30 foot candles white light, and at 90 feet approximately one foot candle.

This new photoelectric relay operates on 110 volt 60 cycle A.C., and is normally supplied with contacts having 2 amps., A.C. non-inductive load capacity. With this new unit a speed of 600 operations per minute can be consistently maintained. The circuit can

be so arranged that no plate current is drawn from the amplifier tube except while the light beam is interrupted, thus increasing the life of the amplifier tube at slow or medium speeds.—*Electronics.*

Out-voltage regulator

THE ROLLER-SMITH COMPANY, 233 Broadway, New York City, has put on the market its new Kathetron "out-voltage regulator," for use on limited-capacity distribution lines, customers' premises, and industrial applications where the input line voltage is reasonably constant but where an objectionable drop in delivered-voltage is caused by the starting of motors or by other relatively heavy demands that produce annoying flickers in lights. The new Kathetron apparatus serves to eliminate all such visible flicker if properly applied, according to the makers.

The apparatus is said to be extremely simple, compact and fool-proof. It has no moving parts, and its life is practically unlimited except for the electronic tube which has an average performance of over one thousand hours. Commercial Kathetron units, giving a maximum boost of 10 per cent, are available in sizes from 2 to 50 kva. per phase, and for pressures of 2,400, 240 and 120 volts.—*Electronics.*

Output meter

A NEW OUTPUT meter of unusual characteristics, announced by The Davenport Company, 158 Summit Street, Newark, N. J., is of the improved copper-oxide-rectifier type and has the extreme sensitivity of 10,000 ohms per volt, r.m.s. With this meter it is possible to measure power levels as low as minus-40 decibels and as high as plus-41 decibels, the latter only on a 500-ohm line.

A feature of this instrument is the possibility of measuring the output or power level correctly at any impedance between zero and 20,000 ohms. This is done without loss of sensitivity by a simple arrangement shown on charts supplied with each meter. Instead of having a number of meters of various impedances to properly terminate or simulate different loads, it is now possible to do all this with one meter.

The type D-180 meter has seven ranges from zero to 200 volts. It has an impedance of 20,000 ohms and the standard meter is mounted in a hand-rubbed walnut box for portable use.—*Electronics.*

Voltage rectifiers, transformers

THE DELTA MANUFACTURING COMPANY, formerly of Cambridge, Mass., makers of Acme-Delta transformers, chokes, and power equipment for radio amateurs, Delta high-voltage rectifiers for broadcast stations, Delta voltage regulators, and other special power conversion equipment, has joined the Raytheon Manufacturing Company. The activities of the combined companies will be carried on under the name of Raytheon Manufacturing Company, Electrical Equipment Division, in a newly acquired plant at 190 Willow Street, Waltham, Mass. In addition, new types of rectifying apparatus for converting a.c. into d.c. are being designed to permit the use of rectifiers in industrial applications where previously only motor generators or storage batteries could be used.—*Electronics.*

Tubes with carbon plates

FEATURING AN ENTIRELY new construction in the line of tubes, the G-242-211, 845, 852, and 203 of the Gordos Products Company, 17 W. 60th Street, New York City, are built with the new carbon plate giving a greater advantage over the old type metal plate, such as overcoming the expansion and contraction of the plate termed as "creeping," and eliminating gaseous disturbances at the same time giving maximum heat dissipation. These tubes have rigid supports, adequate thoriated-tungsten filament, together with a long age schedule insuring maximum life. The Gordos laboratory has been especially careful in the design of the supports for simplicity, rigidity and placement to insure maximum efficiency.—*Electronics.*

High-frequency loudspeaker

IN THE DESCRIPTION of the electro-dynamic high-frequency loudspeaker of the Racon Electric Company, Inc., 52 East Nineteenth Street, New York City, which appeared on page 198 of June *Electronics*, the announcement should have made clear that this new unit is designed to cover a frequency band from 3,000 to 10,000 cycles.—*Electronics.*

All-wave antenna

A SINGLE ANTENNA with an automatic frequency selector whereby a broadcast antenna or short-wave antenna circuit is provided for intercepted signals, with a minimum of background noise, is announced by the Technical Appliance Corporation, 27-26 Jackson Ave., Long Island City, N. Y. A manually-operated switch adjusts the coupling between any set and the downlead circuit, so as to balance the impedances for the most efficient reception.

The new noiseless all-wave antenna system is intended primarily for the usual all-wave receiver. It provides a single antenna for the performance heretofore attained only by using separate broadcast and short-wave antennae. A recently added refinement is an impedance switch in the receiver unit, which provides three choices of impedance coupling between receiver and downlead, for greatest efficiency. By including the coupling and the impedance switch in the all-wave receiver, with the switch actuated by the usual band-changing control, the set can be automatically coupled to the system for the most efficient results. *Electronics*

Resistors

THE MUTER COMPANY, 1225 South Michigan Avenue, Chicago, Ill., has now developed a special line of replacement resistors, similar to the patented Candohm armored wire-wound resistors made to radio-set manufacturers' order. These new replacement Candohms are small enough to be used in practically all radio circuits. They have 1½-inch tinned-wire leads, and the resistance is



accurate and does not change with temperature, thus these resistors are noiseless, thoroughly insulated, and not affected by external conditions. One-watt Candohms are supplied in values from 100 to 25,000 ohms. The resistance of each unit is plainly stamped on its case. —*Electronics*.

Volume controls

THE PRINCIPLE of applying resistance coatings to insulating bases, used in metallized resistors, has now been applied to IRC volume controls introduced by the International Resistance Company, 2100 Arch St., Philadelphia, Pa. In these controls, the resistance coating is permanently bonded to a moisture-proof base by baking at a high temperature. The result is a resistance element that is unusually stable, durable and

permanent under all conditions of use and one that is particularly effective in combating the effects of humidity.

Quiet operation and smooth resistance variation are obtained in IRC controls by three contact fingers with spherical convex surfaces. These glide directly over the resistance element, avoiding any shifting of the points of contact with resulting jumps in resistance as the slider is rotated. Standard IRC volume controls are available with or without switch in any range from 200 ohms to 2 megohms.—*Electronics*.

Magnetic core material

FERROCART IS A magnetic core material for use in antenna coils, R.F. transformers, and I.F. transformers. It is made in two forms, laminated and moulded. A wide variety of shapes and sizes may be had in either type. The permeability can be definitely controlled to meet any requirements from 10 to 13,9, and due to the elimination of eddy-current and hysteresis losses, advantage is taken of this permeability to reduce the copper losses, owing to a much smaller amount of wire being required for a given inductance value. Accompanying this is increased selectivity and sensitivity by a ratio of approximately 2 to 1.

Ferrocart has been in commercial use for two years and is stable from both a chemical and electrical standpoint. The uniformity of cores made after this process is excellent and exceeds all requirements for commercial use.

Ferrocart can be supplied by the Ferrocart Corporation of America, 12 East 41st St., New York, N. Y. It may be had either in cores or in complete coil units to suit practically any circuit design. Engineering services are available to assist set or coil manufacturers in the design or application of any unit. —*Electronics*.

Pressure-type mercury-arc lamp

THE GENERAL ELECTRIC VAPOR LAMP COMPANY, Hoboken, N. J., reports that a new type of high-efficiency, limited-pressure, mercury arc is well along in development. This arc has an efficiency of about 40 lumens per watt, and is compact, a 425 watt unit being contained in a tubular lamp bulb 2 in. in diameter and 13 in. in overall length. The light source itself is 6 in. long and about ½ in. in diameter. The color quality of the light is said to be considerably nearer white than that of the older low-pressure form of the mercury arc, there being additional red and green light of value in panchromatic work. —*Electronics*.

Five-meter antenna

A UNIQUE high-efficiency antenna for 5-meter transmission and reception has just been announced by the E. F. Johnson Company of Waseca, Minn., manufacturers of radio transmitting equipment. The efficiency of the unit is approximately 3 db above that of a simple, current-fed antenna, due to accurate impedance matching secured through a properly designed quarter-wave line

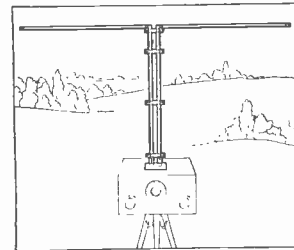

section which also serves as a support. The antenna may be installed horizontally as illustrated or vertically by providing simple supports. It can be quickly set up and dismantled and weighs only 1¼ pounds net. Two models are available with either low-loss glazed porcelain or Mycalex insulation, listing at \$6.50 and \$9.50 respectively.—*Electronics*.

Getter assemblies

THE EMBEDDED getter in the barium-magnesium assemblies marketed by Kemet Labs. Co., 30 East 42nd Street, New York City, consists of standard Kemet barium-magnesium alloy containing approximately 27 per cent Ba and the balance Mg which is generally used by radio tube companies in this country and abroad. The getter in the strontium-barium-magnesium assemblies consists of an alloy containing approximately 20 per cent Sr, 15 per cent Ba, and balance largely Mg.

The advantages of a good getter assembly are listed as: (1) the intimate contact between the embedded getter and the nickel tab results in flashing at a lower temperature, more complete volatilization of the getter, and much greater uniformity in the time of flashing; (2) the convenience of the use of assemblies is self-evident when it is considered that it is only necessary to spot-weld a piece of nickel wire to the assembly and to a member of the mount, and (3) the use of assemblies results in important economies as compared to the cost of getter tablets, nickel tabs and nickel mesh and the assembling and spot-welding involved in their use.

The use of getter assemblies is similar to that of getter tablets and nickel tabs, excepting that some modification of the flashing practice may be necessary or desirable to take advantage of the superior characteristics of the assemblies.—*Electronics*.

3 types of Contacts . . . 3 Materials

— assembled Simply, Cheaply with Self-tapping Screws

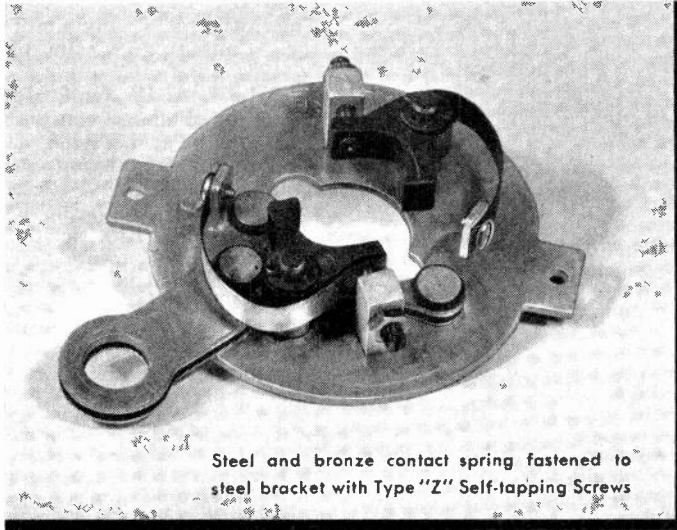

Steel and bronze contact spring fastened to steel bracket with Type "Z" Self-tapping Screws

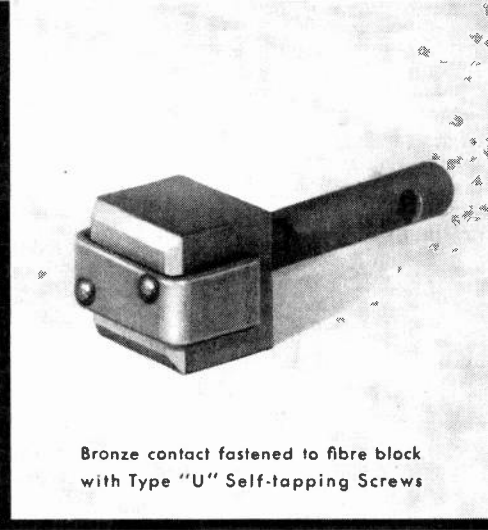

Bronze contact fastened to fibre block with Type "U" Self-tapping Screws



Steel contact strip fastened to Bakelite shoe with Type "U" Self-tapping Screws

One easy operation makes secure fastenings to insulation or metal . . . no tapping, no inserts, no fumbling in hard-to-get-at places!

When a fastening must be made to an insulation material such as fibre, Bakelite, ebony asbestos and slate, or to sheet metal and castings, Parker-Kalon Hardened Self-tapping Screws should always be considered as a

means of reducing assembly costs.

Excellent examples of the possibilities for saving in building electrical apparatus are shown in the 3 contact applications illustrated. While the designs and materials involved differ to a considerable extent, the same fastening simplicity and economy is attained with Self-tapping Screws. The fastenings are made in one easy operation, merely by driving the Screws into plain drilled or molded holes. No tapping is necessary as these unique Screws form a thread in the material as they are driven.

Obviously there is no easier or cheaper method of doing these jobs. Yet, the fastenings also have greater holding power. Unbiased tests have established the fact that Self-tapping Screws make stronger fastenings to both metals and plastics than machine screws in tapped holes or inserts.

Check up on your assemblies. Try out Self-tapping Screws for any jobs which might offer an opportunity for saving. We'll provide free samples for your trials . . . send the coupon.

Where and How to use:-

Type "Z" Hardened Self-tapping Sheet Metal Screws



For joining and making fastenings to molded, cast and laminated plastics; die castings and sheet metal. Just turn Screws into drilled or molded holes. Can be removed and replaced without impairing holding power.

Type "U" Hardened Metallic Drive Screws

This type of Self-tapping Screw is for making permanent fastenings to molded, cast and laminated plastics, also steel and metal castings. Just hammer the Screws into molded or drilled holes for secure fastenings.



PARKER-KALON
HARDENED
Self-tapping Screws

PAT. IN U.S. AND FOREIGN COUNTRIES

PARKER-KALON CORPORATION, 198 Varick Street, New York, N. Y.

Please send information on Self-tapping Screws and free samples for trial on the assemblies described on attached sheet.

Name, Title

Company

Address

form a path of low impedance to ground for each of the image frequencies throughout the band to be received. B. van der Pol and T. J. Weyers, R.C.A. No. 1,961,720.

Two band receiver. Method of suppressing image interference over both bands by using a parallel tuned circuit and a coupling coil connected in series between the input terminals of receiver, an antenna series coil, a fixed condenser common to the circuits having a maximum reactance about one-tenth to one-thirtieth the minimum reactance of either parallel element in the tuned circuit. H. A. Wheeler, Hazeltine Corp. No. 1,960,984.

Dual band receiver. Sectional inductances comprising two coils connected in series but mounted in non-inductive relation and a switching method for simultaneously short-circuit-

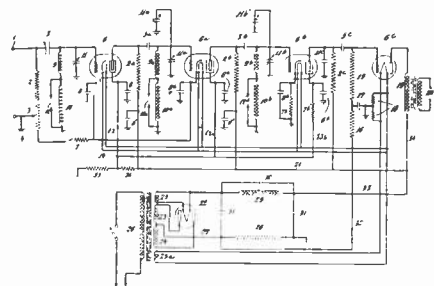

ing all of the non-inductively mounted coils. L. F. Curtis, W. L. Cotter, and L. E. Eastman, United American Bosch Corp. No. 1,960,479.

Oscillator-modulator circuit. An electrode of a four element tube set in common to both incoming and locally generated oscillations. D. E. Harnett, assigned to Hazeltine Corp. No. 1,962,104.

Tuning indicator. Combination with a radio receiver having at least one tuned circuit for selecting signals, a resonance indicator comprising a gaseous discharge lamp having several elec-

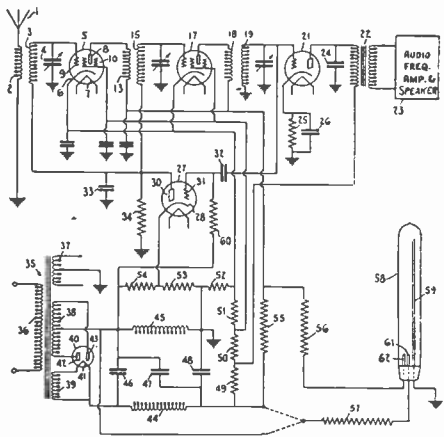

trodes, connected in the receiver at a point such that there exists between the long cathode and anode of the discharge tube a voltage which increases when the radio receiver is tuned to resonance with incoming signals. Alexander Senauke, New York, N. Y. No. 1,961,574.

Direction finding system. Patent No. 1,961,319 to John A. Willoughby, Cambridge, Mass.; No. 1,961,598 to W. Scheppmann, C. Lorenz Co., Berlin;

No. 1,961,206 to Harry Diamond, Washington, D. C., on a twelve course aural type triple modulation directing beacon.

Tone control. Receiving a super-audible signal and utilizing the signal

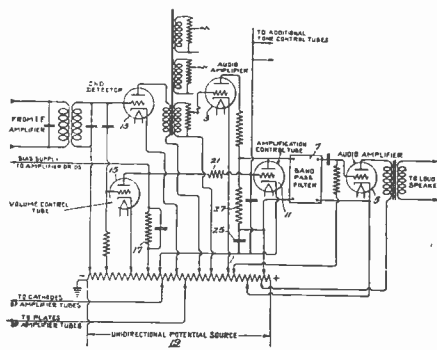

for controlling the range of frequencies to which the audio frequency amplifier is responsive. G. L. Beers, R.C.A. No. 1,961,329.

Television, Cathode Ray Apparatus, Etc.

Scanning system. A series of light-concentrating devices comprising zone plates. H. S. Baird, Shortwave & Television Corp. No. 1,962,474.

Scanning system. Scanning an optical image including means for scanning a light source in one direction to produce a moving light beam, means for selectively and unidimensionally diffusing the beam only in the plane of its motion, and means for periodically displacing the beam to effectively generate a luminous plane. H. P. Donle, assigned to Radio Inventions, Inc. No. 1,961,632.

Patent Suits

1,725,433, F. K. Vreeland, Band-receiving system; 1,730,987, same, Variable band amplifier; 1,749,930, same, Variable circuit element for radio receiving sets, D. C. Del., Doc. E 814, Vreeland Corp. v. Grigsby-Grunow Co. et al. Dismissed Mar. 13, 1934.

1,729,407, L. Stevens, Acoustic diaphragm, D. C., N. D. Ill., E. Div.; Doc. 10214, Stevens Mfg. Corp. v. United Pressed Products Co. Patent held invalid; bill dismissed Nov. 21, 1932.

1,573,374 (a), P. A. Chamberlain, Radio condenser; 1,618,017, F. Lowenstein, Wireless telegraph apparatus; 1,231,764, same, Telephone relay; 1,702,833, W. S. Lemmon, Electrical condenser; 1,811,095, H. J. Round, Thermionic amplifier and detector; 1,403,475, H. D. Arnold, Vacuum tube circuit; 1,465,332, same, Vacuum tube amplifier; 1,403,932, R. H. Wilson, Electron discharge device; Re. 18,579, Ballantine & Hull, Demodulator, D. C., N. D. Ill., E. Div., Doc. 13657, Radio Corp. of America et al. v. W. A. Garl, et al (Ad-Gar Products Co.). Consent decree holding patents valid and infringed Feb. 24, 1934.

1,573,374 (b), P. A. Chamberlain, Radio condenser; 1,702,833, W. S. Lemmon, Electrical condenser; 1,811,095, H. J. Round, Thermionic amplifier and detector; Re. 18,916, J. G. Aceves, Supply circuit for radio sets; Re. 18,579, Bal-

lantine & Hull, Demodulator and method of demodulation; 1,618,017, F. Lowenstein, Wireless telegraph apparatus; 1,231,764, same, Telephone relay; 1,403,475, H. D. Arnold, Vacuum tube circuit; 1,465,332, same, Vacuum tube amplifier; 1,403,932, R. H. Wilson, Electron discharge device; 1,507,016, L. de Forest, Radio signaling system; 1,507,017, same, Wireless telegraph and telephone system, D. C., E. D. Mich. (Detroit), Doc. 6271, Radio Corp. of America et al. v. Plymouth Radio Co., Inc. Consent decree for plaintiff Mar. 27, 1934.

1,251,377, A. W. Hull, Method of and means for obtaining constant direct current potentials; 1,297,188, I. Langmuir, System for amplifying variable currents; 1,477,898, C. W. Rice, Amplifying system, D. C., N. D. Ill., E. Div., Doc. 13656, General Electric Co. v. W. A. Garl et al. Consent decree holding patent valid and infringed Feb. 24, 1934.

1,141,402, R. D. Mershon, Electrolytic apparatus employing filmed electrodes; 1,784,674, same, Film formation and operation of electrolytic condenser and other apparatus, appeal filed Mar. 31, 1934, C. C. A., 2d Cir., Doc. 13321, R. D. Mershon et al. v. J. F. O'Neill et al.

1,167,299. (See 1,364,263.)

1,173,079 (a), E. F. Alexanderson, Selective tuning system; 1,251,377, A. W. Hull, Method of and means for obtaining constant direct current potentials; 1,573,374, 1,666,163, P. A. Chamberlain, Radio condenser; 1,702,833, W. S. Lemmon, Electrical condenser; 1,728,879, Rice & Kellogg, Amplifying system, D. C., N. D. Ill.; E. Div., Doc. 11849, Radio Corp. of America et al. v. Goldblatt Bros., Inc. Consent decree holding patents valid and infringed April 20, 1933.

1,173,079 (b), E. F. Alexanderson, Selective tuning system; 1,195,632, W. C. White, Circuit connections of electron discharge apparatus; 1,231,764, F. Lowenstein, Telephone relay; 1,251,377, A. W. Hull, Method of and means for obtaining constant direct current potentials; 1,426,754, R. C. Mathes, Circuits for electron discharge devices, D. C. N. J., Doc. E 3320, Radio Corp. of America et al. v. Shamrock Mfg. Co. Discontinued June 14, 1933.

1,403,475, H. D. Arnold, Vacuum tube circuit; 1,465,332, same, Vacuum tube amplifier, D. C., N. D. Ill.; E. Div., Doc. 11850, Radio Corp. of America et al. v. Goldblatt Bros., Inc. Consent decree holding patents valid and infringed April 20, 1933.

Re. 15,278, I. Langmuir, Electron discharge apparatus; 1,261,708, W. D. Coolidge, Electron discharge device; 1,287,265, S. Dushman, Electrical discharge device; 1,374,679, J. B. Pratt, Degasifying process; 1,687,505, H. J. Nolte, Electron discharge device; 1,794,315, D. A. Mullaney, Electron discharge apparatus, filed Feb. 6, 1934, D. C. N. J., Doc. E 4809, General Electric Co. v. Federal Telegraph Co.

1,623,996, P. S. Carter, Radio transmission system; 1,909,610, same, Electric circuit; 1,884,006, N. E. Lindenblad, Antenna; 1,927,522, same, Antenna for radio communication, filed Apr. 21, 1934, D. C., E. D. N. Y., Doc. E 7234, Radio Corp. of America v. Mackay Radio & Telegraph Co., Inc.

Again
**ERIE
 LEADS**
 with the
NEW
Midget **SUPPRESSOR**

Think of it . . . a suppressor only slightly larger than a standard spark plug nut! Such is the Erie type A-1 midget, the most outstanding development in suppressor design in years. With overall dimensions of $\frac{29}{32}$ " in length and $\frac{29}{64}$ " in diameter, it represents a compactness hitherto thought impossible.

Efficiency has not been sacrificed to obtain this reduction in size. Life tests run under a load of $\frac{1}{4}$ " spark gap and at 300° F. resulted in a drop of less than 6% in resistance value after 250 hours.

Erie midget suppressors can be easily and quickly installed on any car, and will fit number 8, 8½ and 9 spark plug threads. Before filling your next requirements, investigate this distinctive improvement. We will gladly send you additional data and samples.

ERIE RESISTOR CORPORATION

ERIE, PA.

Factories in ERIE, PA. - TORONTO, CANADA - LONDON, ENG.

RECEIVED AT

11 EAST 55th STREET

PHONE: PLAZA 3-4507

STANDARD TIME INDICATED ON THIS MESSAGE

Postal Telegraph

THE INTERNATIONAL SYSTEM

Commercial Cables TELEGRAMS All America Cables

Mackay Radio

This is a full rate Telegram, Cablegram or Radiogram unless otherwise indicated by a flag in the check or in the address.

DL	DAY LETTER
NL	NIGHT LETTER
NM	NIGHT MESSAGE
LCB	DEFERRED CABLE
NLT	NIGHT CABLE LETTER
WLT	WEEK END CABLE LETTER
	RADIOGRAM

Form 160B NA3 47 EXPED VIA MACKAYRADIO

RADIO LITTLEAMERICA VIA SANFRANCISCO CALIF JUN 4 1934

MCNEIL

BEVERLY HOTEL NEWYORK

FOR BRUSH DEVELOPMENT CO CLEVELAND OHIO QUOTE WE ARE HAPPY TO INFORM YOU THAT BRUSH MICROPHONES ARE BEING USED IN RADIO BROADCASTS FROM THE SECOND BYRD ANTARCTIC EXPEDITION AT LITTLEAMERICA AND ACCORDING TO ENGINEERS DYER AND HUTCHINSON ARE GIVING EXCELLENT RESULTS UNQUOTE

MURPHY.

JUN 4 719A

BRUSH Soundcell Microphones are being widely used where ruggedness and reliability are required.

THE BRUSH DEVELOPMENT COMPANY
Cor. Perkins & E. 40th St. Cleveland, Ohio

**REDUCES
MATERIAL
AND LABOR
COSTS ---
INCREASES
PRODUCTION**

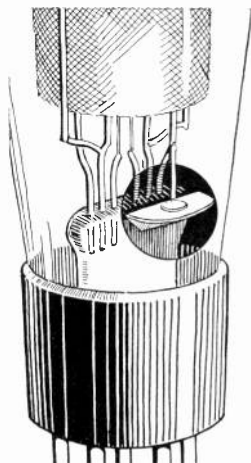

The New **BAREX**
IMBEDDED
GETTER

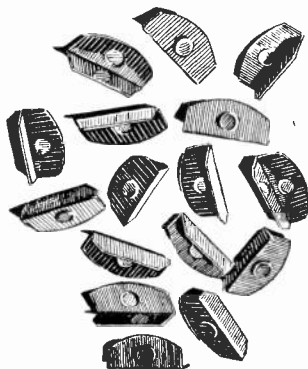

Manufactured under letters patent No. 1922162.

A new type Barium Getter, securely bonded as integral part of metal flag — vaporizes completely, minimizes splash—for all tubes. Reduces shrinkage substantially—ask about it.

KING LABS., INC.
237 W. Division Street,
SYRACUSE, N. Y.

ENAMELITZ

Reduce manufacturing costs on I.F. and R.F. coils through the use of Enamelitz—"Litz" wire without a fabric covering.

Three Fold Savings—

1. Cost of wire
2. More coils per pound of wire
3. Less space—Greater safety

Sample and Technical Bulletin on Request.

Other Acme Wire Co. Products

Magnet Wire (all insulations)
Coils, Magnet Wire Wound
Varnished Insulations

(Cambric, paper, silk, tape)

Parvot Condensers

(Filter, By-pass, Power Factor Correction)

Aerial Wire

(Stranded and Solid—Bare or Enameled)

For over 25 Years, suppliers to the largest radio and electrical manufacturers.

THE ACME WIRE CO.
New Haven, Conn.

Remote control

for auto-radio receivers

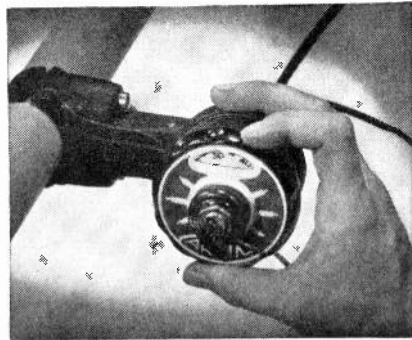

RECENT auto-radio trends indicate the demand for remote controls fastened to the steering post for convenience in tuning.

In keeping with the de luxe interior appointments which characterize even the lowest priced cars, a number of manufacturers are housing

their remote controls in handsomely styled Bakelite Molded cases. The Arvin control illustrated here employs a Bakelite Molded housing in an attractive mahogany effect. Tuning is accomplished by rotating the body of the housing while the escutcheon remains stationary. The volume control knob in the center and the handle of the locking key are also formed in Bakelite Molded in the same pleasing finish.

Bakelite materials are ideal for auto-radio service because they provide lasting beauty of color and finish, light weight, and the strength to resist the vibrations and shocks of the road. In addition, these materials are high in insulation value and are unaffected by temperature and atmospheric variations, retaining their form and dimensions indefinitely.

These materials are completely described in our new editions of booklets 13M, "Bakelite Molded", and 13L, "Bakelite Laminated", copies of which will be mailed to you promptly upon receipt of request.



Arvin Automobile Radio Control with housing, knob and key handle of Bakelite Molded. Manufactured by Nobliit-Sparks Industries, Inc. Columbus, Indiana.



BAKELITE CORPORATION, 247 Park Avenue, New York, N.Y. 43 East Ohio Street, Chicago, Ill.
 BAKELITE CORPORATION OF CANADA, LIMITED, 163 Dufferin Street, Toronto, Ontario, Canada

BAKELITE

REGISTERED U.S. PAT. OFF. The registered trade mark shown above designates materials manufactured by Bakelite Corporation. Under the design "B" is the numerical sign for infinity, an unlimited quantity. It symbolizes the infinite number of present and future uses of Bakelite Corporation's products.

THE MATERIAL OF A THOUSAND USES



EXECUTIVES and engineers who insist on the finest instruments obtainable say that the name "Triplett" on an instrument is their assurance of advanced design . . . their proof of precision construction . . . their guarantee of dependable and permanent accuracy. Triplett instruments were designed by prominent instrument engineers and are the finest development of their many years of experience. In spite of the fact that these instruments were announced only a short time ago, they are already dominating the field and have come to be regarded as the yardstick of today's instrument performance and value. The new and finer line of Triplett Instruments established a new criterion of value in instruments—because they have built into them the greater worth which every one has come to identify with the name "Triplett."

The Triplett Portable Instrument shown here serves a double purpose. It can be used as a regular portable instrument and as the new adjustable type. Before starting a chart, the engineer can adjust the meter until he can readily see the dial regardless of where he places it. A single glance at the upraised easy-to-read dial gives him the information he desires.

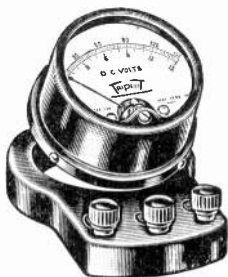

Your Jobber Can Supply You

Compare Triplett Instruments with any other make. Prove their superiority for yourself.

The TRIPLETT ELECTRICAL INSTRUMENT COMPANY

79 Main Street

Bluffton, Ohio



The Triplett Electrical Instrument Co.,
79 Main St., Bluffton, Ohio

Gentlemen: Send me catalog on Triplett Instruments . . . and complete line of radio servicing instruments.

Name

Street Address

City State

PHONOGRAPH

ELECTRIC MOTORS.
one and two speeds

SPRING MOTORS
one and two speeds

PICK-UPS

REPRODUCERS

HERMANN THORENS
S. A.
STE-CROIX
SWITZERLAND

AMERICAN
BRANCH
HOUSE

THORENS, Inc.
450 FOURTH AVENUE
NEW YORK, N. Y.

APPLIED ACOUSTICS

By
H. F. OLSON, E.E., Ph.D. & F. MASSA, B.S., M. Sc.
Acoustical Research Engineers, RCA Victor Co., Inc.
444 Pages 228 Figs. Fabrikoid \$4.50

A MODERN book on the theory, design, construction, operation and analysis of modern acoustical and electro-acoustical apparatus. Includes analyses of rooms, studios, theatres and operation of microphones, loud speakers and systems in modern environments and conditions. Audio-frequency oscillators, amplifiers and electro-acoustical measurements are fully described.

P. BLAKISTON'S SON & Co., INC.
1012 WALNUT STREET, PHILADELPHIA

CANDOHMS

ARMoured WIRE WOUND RESISTORS

WILL LOWER YOUR COSTS

OVER EIGHT MILLION IN USE
MAY WE SAMPLE AND QUOTE

THE MUTER COMPANY

1255 So. Michigan Ave., Chicago

GOAT *form-fitting* TUBE SHIELDS

*... the distinguishing mark
of the modern*

HIGH FIDELITY RECEIVER



Better performance, improved spacing of components and low cost are among the factors which are leading designers of auto radios, portables and compacts to use Goat Form-fitting Tube Shields.



Because of the better shielding offered—against both magnetic and electrostatic disturbances—Goat Shields have been accepted by many manufacturers of modern high fidelity receivers.



Goat-shielded tubes require practically no more space than the tubes themselves, making it possible to locate tubes closer in the chassis, thereby reducing overall chassis dimensions and the materials involved.

And these modern shields actually cost less than space-consuming "tin cans."

Ask for a copy of the new Goat Engineering Bulletin.

—a type for every tube

GOAT RADIO TUBE
PARTS INCORPORATED

314 DEAN ST., BROOKLYN, N. Y.



FOR UNIFORM INSULATION USE TEXTOLITE LAMINATED

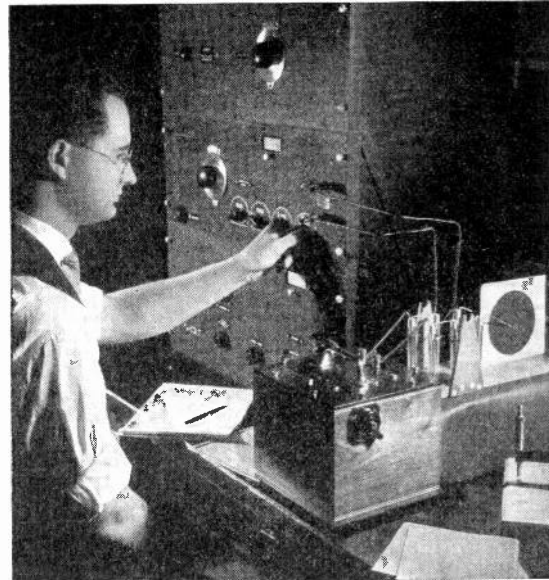

Testing Textolite for insulating qualities

THE high quality of performance expected of Textolite-laminated products demands strict adherence to the exacting raw-material specifications written by General Electric designing engineers. Rigid acceptance tests are made on all raw materials before they are used.

Careful testing of material prior to manufacture results in uniformity of electrical and mechanical characteristics of the finished product. And to make certain of such uniformity there is precise and complete testing equipment on the job—operated with skill and alertness—to detect and reject any finished material which does not meet the high standards set for Textolite laminated.

Improve your product by using Textolite. Write our distributor, GENERAL LAMINATED PRODUCTS, INC., 233 Spring St., New York City, for prices and complete information on all Textolite laminated materials. There is a right grade for your product.

942-21

GENERAL  ELECTRIC

Just off the press—new

REMLER ATTENUATOR

Catalogue Sheet With
Complete Engineering Data

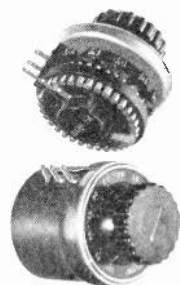

Noise, fading and "jerky" attenuation eliminated by exclusive improvements. Accuracy assured by newly perfected Remler measuring device. Highly recommended for broadcast apparatus, sound recording and projection equipment. Attenuation variable in 27 steps of 1-2/3 db. per step up to 45 db., fading in 3 additional increasing steps from 45 db. to infinity. Attenuation change halved as switch arm spans adjacent contacts resulting in attenuation of 5/6 db. per step. Impedance practically constant over entire range of pad. Essentially flat frequency characteristic.

Practical for low level mixing of dynamic or ribbon microphones

Standard impedances of 50, 200 and 500 ohms. Special values up to 1000 ohms and logarithmically tapped potentiometers for grid main gain up to 200,000 ohms, supplied on short notice.

Other features include non-inductive, bakelite covered, moisture-proofed bifilar windings. Handles power levels up to plus 24 db. Diameter 2 3/4 in.; depth back of panel 2 1/16 in.; mounts 2 3/8 in. hole or by three 6-32 screws on 1 7/16 in. diameter circle.

LA-5 Ladder Type
Net Price

\$10.80

Send for new Catalogue Sheets

REMLER COMPANY, Ltd.

2101 Bryant Street

San Francisco, Calif.

REMLER—THE RADIO FIRM AS OLD AS RADIO

SHAKEPROOF

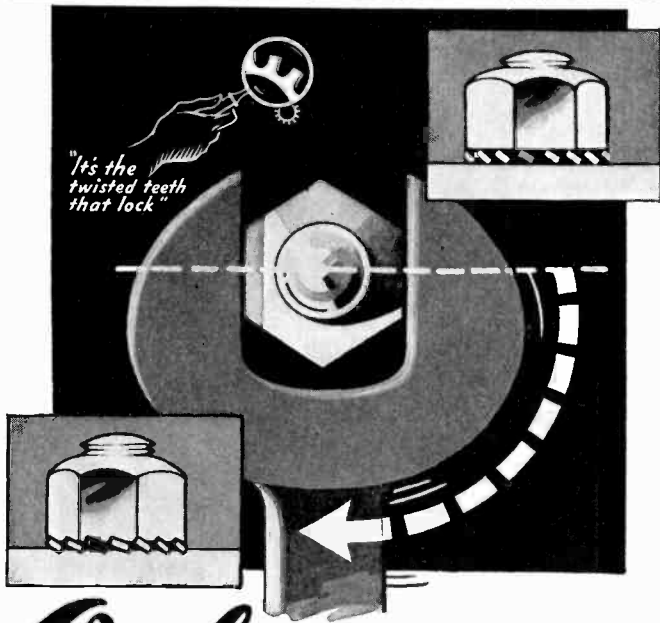

Only 1/4 turn
LOCKS IT TIGHT!

GREATER speed on the production line is one of the big advantages in using Shakeproof Lock Washers and Shakeproof Locking Terminals. When the nut or screw is turned down and meets the lock washer, only one-quarter turn more locks it absolutely tight. This fast and positive locking action is made possible by the powerful twisted teeth that bite into both work and nut surfaces and never let go. Improve the performance of your product and save money on production costs by making your product 100% Shakeproof. Write today for complete catalog and free testing samples!

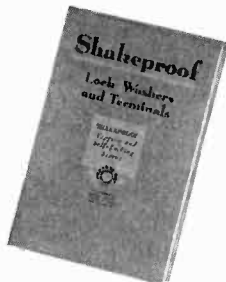

Send today for your free copy of this complete Shakeproof Catalog. Explains thoroughly the many advantages that Shakeproof offers - also shows new patented Shakeproof products.

SHAKEPROOF Lock Washer Company

Distributors of Shakeproof Products
Manufactured by Illinois Tool Works

2539 N. Keeler Ave.

Chicago, Ill.



U. S. Pat. 1,419,564-1,604,122-1,697,954-1,782,387-Other Pat. Pending-Foreign Pat.

—ELMET— MOLY



FOR
GRID WIRES

SUPPORT WIRES

**ELECTRIC FURNACE
HEATING ELEMENTS**

ALSO FOR
**SCREEN GRIDS--CATHODE COILS
MANDRELS--CONTACTS, ETC.**

ALL OF THE ABOVE PRODUCTS MAY
BE HAD IN VARIOUS COMPOUNDS OF
MOLYBDENUM-TUNGSTEN



Write for Information and Prices

American Electro Metal Corp.
Lewiston Maine

HEINTZ SINCE 1919 and KAUFMAN Ltd.

PIONEER Radio Engineers, Manufacturers and
Consultants.

We invite the opportunity to assist with your
problems and quote prices.

311 California St., SAN FRANCISCO, Cal.

MACHINERY AND ACCESSORIES

for the production of

ELECTRON TUBES, NEON SIGNS, PHOTO CELLS
X-RAY TUBES, RADIO VALVES, INCANDESCENT
LAMPS, AND SIMILAR PRODUCTS.

WELDING MACHINES

1/2 to 100 K.V.A.
Foot Operated—Motor Driven
For welding metals having a combined
thickness from .001 in. to .500 in.

WELDERS AS LOW AS
\$ 35.00

Advise Us of Your Needs.

EISLER ENGINEERING CO. Inc.,

740 So. 13th St.

Newark, N. J.

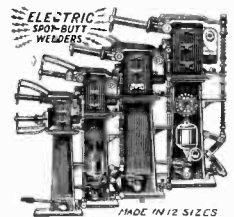

MADE IN U.S.A.

How much is the earth influenced by its cosmic environment?

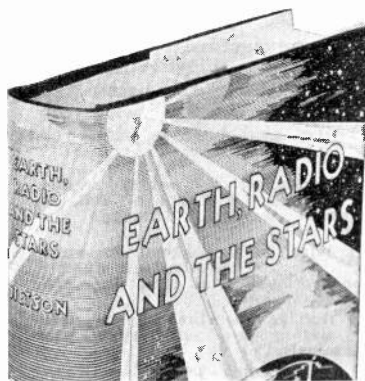

Here is a new book that brings together the existing information of the chemist, the physicist, the radio engineer and the geologist, as well as the astronomer, to synthesize for us what is known about the earth and its relation to its cosmic environment.

Now ready

EARTH, RADIO and the STARS

by HARLAN TRUE STETSON
Research Associate in Geophysics, Harvard University
330 pages, 5½ x 8, illustrated, \$3.00

THIS book brings together recent conspicuous developments in astronomy and its related fields which suggests more intimate relationship between man and his cosmic environment. It is a synthesis of information now available in regard to the earth, its movements, and its constitution; the nature of the sun and its radiation, and its effects on human affairs; sun spots, and the correlation of solar phenomena with terrestrial affairs such as the earth's magnetism and radio transmission. It shows what further data astronomy and physics can give from observations of meteors, aurorae, vast stretches of cosmic clouds, and the mystifying cosmic rays. It is an interrelation of all fields of science for the solution of problems concerning the earth in the cosmic scheme.

Discusses such questions as:

- | | |
|--|---|
| Do sun-spots really affect the earth? | deteriorate and local reception improve in the next five years? |
| Do lakes change their levels with the sun-spot cycle? | Is the earth's magnetism constantly changing? |
| Does the moon influence the earth? | Have meteors ever been heard in the radio? |
| Are there tides in the solid earth as well as in the oceans? | Do radio waves come from the heart of the galaxy? |
| Is the earth's crust slipping under cosmic forces? | Are cosmic rays the birth cries or death cries of atoms? |
| Does the moon affect radio reception? | What is known about radio echoes from distant space? |
| Are there electric tides in the earth's atmosphere? | What is cosmecology? |
| Will long distance radio reception | |

See it 10 days on approval—Send this coupon

ON-APPROVAL COUPON

McGRAW-HILL BOOK COMPANY, INC.
330 West 42d Street, New York, N. Y.

Send me for 10 days' examination, subject to approval or return, Stetson—Earth, Radio and the Stars. At the end of 10 days I agree to pay \$3.00 plus a few cents for postage and delivery, or return the book postpaid. (We pay postage on orders accompanied by remittance.)

Name

Address

City and State

Position

Company L. 7-34
(Books sent on approval in U. S. and Canada only.)

PROBLEMS?



MAYBE THE SOLUTION TO YOUR PROBLEMS RESTS WITH US—



A Cinch plug, "the size of a quarter" solved this engineer's problem

This Company was founded on the policy "your problems are our problems." A scientifically trained organization, flexible in applying their services and alert to please—commended by satisfied customers everywhere—tell you that your problems may be—



Here the solution was a 3/8" plug button delivered two hours after the need for it was voiced



A CINCH FOR CINCH

CINCH

MANUFACTURING CORPORATION
2335 WEST VAN BUREN STREET • CHICAGO, ILLINOIS
Subsidiary of United-Carr Fastener Corp., Cambridge, Mass.

Cinch Radio sockets are licensed under H. H. Eby socket patents

All the advantages of WIRE-WOUND RESISTORS

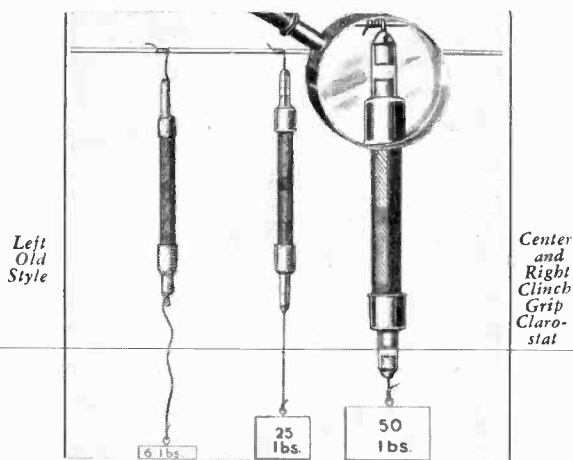

But competitive in price
with CARBON

CLAROSTAT Clinch Grip Terminals

insure easy assembly and
trouble-free performance

The exclusive method of clinching terminals in CLAROSTAT WIRE-WOUND RESISTORS is an outstanding improvement. Resistor noises are definitely reduced. Hence the fast growing acceptance of CLINCH GRIP TERMINALS for use in receivers, amplifiers and special equipment for sound, transmission and industrial use.

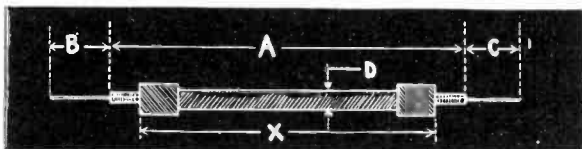

"X" directly proportional to watt dissipation.

Type "FX"—Watts per Inch = one-half. "D" = 1/8 inch.

Type "FY"—Watts per Inch = one. "D" = 1/4 inch.

"A" = "X" + 1/2 inch.

"B" = "C" = 2 inches. (Std.)

All linear dimensions ± 1/8 inch.

RESISTANCE TOLERANCE: ± 10%

and not more than 1% change of original value when entire resistor is wound upon a 3/8 inch diameter arbor.

WATT RATING: Continuous.
TERMINALS: No. 20 B & S tin-coated copper wire.

CODE USED:

1", "FX"—500—Type "FX," 1 watt, 500 ohms.

4", "FY"—250 Type "FY," 4 watts, 250 ohms.

STANDARD STOCK: All popular resistance values and sizes "FX."

TENSILE STRENGTH:

Type "FX"—not less than 10 lbs.

Type "FY"—not less than 25 lbs.

Write for Free Test Samples

The surest way to prove the advantages of CLAROSTAT RESISTORS is to try them. If you will indicate the resistance values and wattages required on the coupon below, we will gladly send you FREE SAMPLES for trial.



CLAROSTAT
MANUFACTURING CO., Inc.
285 North 6th St.
BROOKLYN, N. Y.



Clarostat Mfg. Company, Inc., 285 North 6th St., Brooklyn, N. Y.
Gentlemen: We would like to try the new Clarostat Wire-Wound Resistors with CLINCH GRIP TERMINALS. Will you kindly send FREE SAMPLES in the following sizes?

Name _____
Company _____
Address _____

The Inside Story of C-D "CUBS"

Low cost alone does not account for the widespread popularity of C-D "CUBS"—those compact, convenient, rugged tubular paper condensers. There is inherent quality which, for those set manufacturers and others

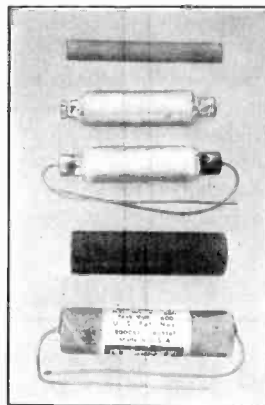

whose assemblies *must stand up*, is always the prime factor. Split a "CUB" with your knife, and here is what you find:

1 Non-inductively wound section. Overlapping leaves of foil, on wooden mandrel. Thorough impregnation.

2 Wire leads soldered to metal cap. Non-corrosive cap clamped on overlapping foil ends. Low contact resistance.

3 Outside sleeving slipped over section and ends spun over terminals.

4 Entire unit thoroughly waxed as still another protection against humidity.

Nothing skimped here. Everything the best. Only an enormous production made possible by widespread demand can produce such quality at such low prices.

Write for Data on C-D "CUBS" or any other type of condenser in which you may be interested. And do not hesitate to place your condenser problems before our engineers.



CORNELL-DUBILIER
CORPORATION

4380 Bronx Boulevard, New York City

UNLESS YOU HAVE USED

CETRON PHOTO CELLS

You do not really know how efficient and dependable photo cells can be.

Comparisons with other photo cells will prove their superiority. Samples will be sent to responsible companies and laboratories for test and trial. Our Engineers will gladly assist on your electronic problems.

Write today for complete technical data.

CONTINENTAL ELECTRIC CO.

First and Illinois Sts., St. Charles, Ill.

Cable Address: CONTINENTAL

A TRIAL WILL CONVINCING YOU

30 Years' Experience
Insures Dependability

We Manufacture

PERMANENT MAGNETS
METAL STAMPINGS

TOOLS and DIES
LAMINATIONS

THOMAS & SKINNER STEEL PRODUCTS CO.

23d St. at Alford

Indianapolis, Ind.

COILS

R. F.—I. F.—CHOKES

We are in a position to serve both large and small manufacturers in the radio and industrial fields.

QUALITY GUARANTEED—PROMPT SERVICE—PRICES COMPETITIVE.

If you will submit your specifications, we will be pleased to quote and send samples.

EDWIN I. GUTHMAN & CO., INC.

1321 So. Michigan Avenue CHICAGO
Telephones: Victory 2291-2292



Laminated Bakelite

Sheets, Tubes, Rods, Fabricated Parts

Made of the finest raw materials, including genuine Bakelite Resins. Uniformity of quality assured by use of the most advanced automatic control equipment.

Write for complete information and prices.

MICA INSULATOR COMPANY

200 Varick St., New York, N. Y.; 542 So. Dearborn St., Chicago, Ill.; 1330 Schofield Bldg., Cleveland. Branches at Birmingham, Boston, Cincinnati, Los Angeles, San Francisco, Seattle. Canada: Montreal, Toronto.

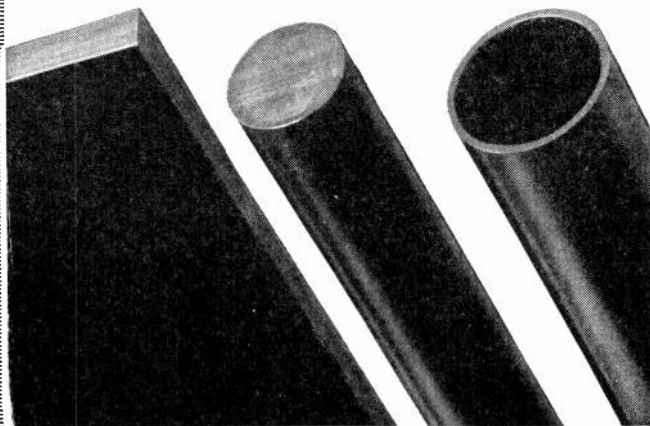

New Noiseless Speech Equipment

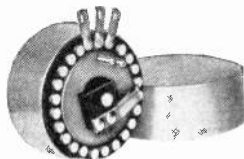

LA-250, Ladder network, 20 step, 1 1/2 and 2 d.b. per step, 100% shielded, 2 1/2" dia. x 1 7/8" deep, etched dial and pointed knob.

Daven Control and Resistor products are standard with broadcast chains and recording studios. Daven bulletins contain valuable data on control and resistor problems. Let us know of your standard or special problems.

Check items in which you are interested for literature.

Speech Input Control Apparatus Attenuators Potentiometers Faders
Volume Indicators Output Meters Line Equalizers Attenuation Boxes
Multipliers Decade Resistances Resistances Glastor Super Davohm
Precision Resistors

Name _____
Company _____ Address _____

THE DAVEN COMPANY
158-160 SUMMIT STREET, NEWARK, NEW JERSEY

SEARCHLIGHT SECTION

EMPLOYMENT BUSINESS OPPORTUNITIES EQUIPMENT—Used or Special

UNDISPLAYED—RATE PER WORD
Positions Wanted—5 cents a word, minimum charge—\$1.00 an insertion.
Positions Vacant and other classifications—10 cents a word, minimum charge \$2.00 an insertion. Allow 10 words for box address. No additional charge for forwarding replies.
Discount of 10% for payment in advance on 4 consecutive insertions of undisplayed advertisements.
Proposals—40 cents a line.

DISPLAYED—RATE PER INCH:
1 inch \$5.00
2 to 3 inches 4.75 an inch
4 to 7 inches 4.50 an inch
Other spaces and contract rates on request.
An advertising inch is measured vertically on one column, 3 columns—30 inches—to a page.

COPY FOR NEW ADVERTISEMENTS RECEIVED UNTIL 3 P. M. ON THE 4TH OF THE MONTH.

PROFESSIONAL SERVICES

Consulting—Design—Research
Testing—Measurement
Development—Acoustics—Patents

"SEARCHLIGHT"

IS

Opportunity Advertising

—to help you get what you want.
—to help you sell what you no longer need.

Take Advantage Of It

For Every Business Want

"Think SEARCHLIGHT First"

G-7

HIGH GRADE NEW AND USED ELECTRON TUBE EQUIPMENT

Write for Bulletin Showing Savings From 20% to 80%

KAHLE ENGINEERING CORPORATION
Specialists in Equipment and Methods for the Manufacture of Neon Tubes, Radio Tubes, Incandescent Lamps, Photo Cells, X-ray Tubes, etc.
350 Manhattan Ave., Union City, N. J.

All types of High Grade New and Used Equipment for the manufacture of Electron Tubes.

Lowest prices on the market.

AMERICAN ELECTRICAL SALES CO.
65 East 8th St., New York, N. Y.

SAVE MONEY

Surplus Machine Screws and Insulated Wire all types and sizes.
Several Stimpson Eyeletters and Elster Spot Welders.

Send us your requirements.

ECK ELECTRIC MANUFACTURING CO.
50 West 3rd St., New York City
Phone ALgonquin 4-8133

ELECTRICAL TESTING LABORATORIES

Characteristics and Life Tests of Vacuum Tubes
Tests of photocells, glow lamps, crater lamps.
Tests of electronic and optical devices.
80th Street and East End Avenue
New York, N. Y.
Phone: Butterfield 8-2600

JENKINS & ADAIR, INC.

Engineers

Designers, developers, and manufacturers of accessories and essentials for recording, broadcasting and testing at sound frequencies.

3333 Belmont Avenue, Chicago, U. S. A.
Cable Address: Jenkair Telephone: Keystone 2130

THE SOLUTION OF YOUR PROBLEM

might be found through enlisting the services of the firms whose cards appear on this page.

SEEN ... NOT HEARD

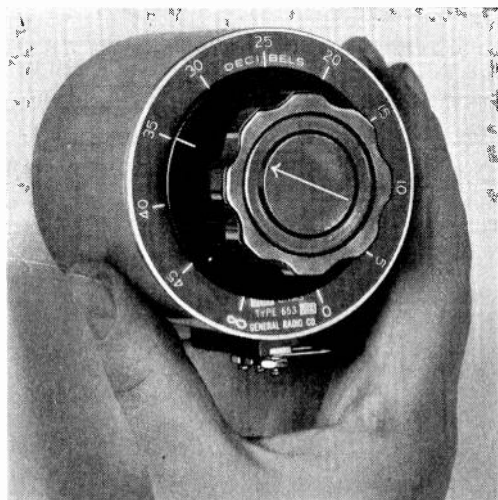

Volume controls also should be seen and not heard. Silence is the outstanding characteristic of the Type 653 Control. Its rigid, compact construction makes for ease of installation and trouble-free operation.

Specifications

Range 0 db. to total cut-off
(0.75 db. steps)

Shielding—Aluminum dust and electrostatic shield.

Switches—3-bladed phosphor bronze.

Diameter $2\frac{3}{4}$ "—Depth $2\frac{5}{8}$ "

Type 653-MA—50 ohms

Type 653-MB—200 ohms

Type 653-MC—500 ohms

Price \$12.50

GENERAL RADIO COMPANY
Cambridge, Massachusetts

SPEED with CANNON PLUGS



AMERICA'S greatest air liners entrust their speed, safety and efficiency to CANNON Cable Connectors. Speed is inherent in CANNON Plugs—speed in service, speed in production, speed in meeting the ever-changing demands of modern progress.

That's why America's greatest manufacturing institutions standardize on CANNON Plugs . . . CANNON produces finished models in less time than other plants produce blueprints . . . Clients bring us their ideas and overnight they become operating realities.

Time is the essence of air transport . . . and CANNON Products are increasingly popular in the air service.

Write for New Airship Plug Catalog.

CANNON ELECTRIC DEVELOPMENT CO.

MANUFACTURING ENGINEERS

Main Office: 420 West Avenue 33, Los Angeles, Calif.

Eastern Sales Office: 220 Fifth Ave.
New York, N. Y.



Representatives:
Chicago: Jenkins & Adair, Inc., 3333 Belmont Ave.
Bombay, India: Eastern Electric & Engineering Co.,
175 Hornby Road, Fort, Bombay, India

Autelco Micro Switch Relay Instant, Accurate Operation

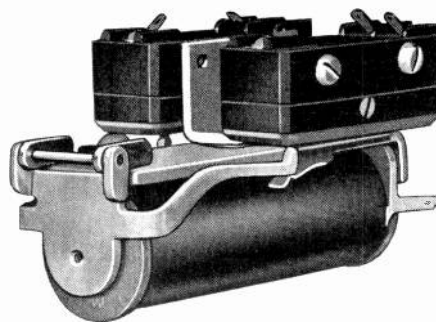

The unit consisting of Autelco relay equipped with Burgess micro switch forms an unbeatable combination. The complete reliability of Autelco relay operation is well known. The Burgess micro switch gives fast, positive snap action on minimum relay motion. Both units are exceptionally sturdy in construction, and will stand up to hard service. Operation is secured on .001" motion and 4 ounces pressure differential. Furnished in D.C. models. Rating per contact: 8 amps. 110 V. A.C.; 4 amps. 220 V. A.C. (Contact not recommended for D.C. loads).

The Autelco line of relays, made by Automatic Electric Company, is a forty-year development embracing both A.C. and D.C. types for every use. Send for Catalog 4016, which gives detailed descriptive and ordering information.

American Automatic Electric
Sales Company

1033 West Van Buren Street

Chicago

CONTENTS for JULY, 1934

Front cover—"Loudspeakers" Photograph by Austin Armer, The Magnavox Company	
Synchronized broadcasting	203
Revise transmitter sales practices	204
The prospects of high-fidelity transmission	206
Electronic aids for the paralyzed	209
A-C operated high gain amplifiers BY DANIEL E. NOBLE	210
Processes in vacuum tube manufacture BY E. R. WAGNER, PH.D.	213
Vibrator power supply from dry cells BY WALTER VAN B. ROBERTS	214
Highlights on electronic devices in industry	216
A mobile printer for police and aircraft radio	218
Reactance chart for the middle radio frequencies	219
Notes on electron tubes and circuits	220
Editorials	222
Books for engineers using electron tubes	224
Electronic music from vibrating reeds BY ROBERT G. SILBAR	226
Review of electronic literature	227
New products	230
U. S. patents	232

INDEX TO ADVERTISERS

This index is published as a convenience to the reader. Every care is taken to make it accurate but *Electronics* assumes no responsibility for errors or omissions.

Page	Page
Acme Wire Co. 8	Parker-Kalon Corp. 5
Allen Bradley Co. 18	RCA Radiotron Co., Inc. Back Cover
American Automatic Electric Sales Co. 16	Remler Co., Ltd. 11
American Electro Metal Corp. 12	Shakeproof Lock Washer Co. 12
Bakelite Corp. 9	Thomas & Skinner Steel Prod. Co. 14
Blakiston's Son & Co., Inc. 10	Thorens, Inc. 10
Brush Development Co. 8	Triplett Elec. Instr. Co. 10
Cannon Elec. Development Co. 16	Western Electric Co. 3
Cinch Mfg. Corp. 13	Weston Elec. Instrument Corp. 17
Clarostat Mfg. Co. 14	White Dental Mfg. Co., S. S. Inside Back Cover
Continental Electric Co. 14	
Cornell-Dubilier Corp. 14	
Daven Co. 15	Yaxley Mfg. Co. 4
Eisler Engineering Co., Inc. 12	
Erie Resistor Corp. 7	
Formica Insulation Co. 2	Professional Services . . . 15
General Electric Co. 11	
General Radio Co. 16	
Goat Radio Tube Parts, Inc. 11	
Guthman & Co., Inc., Edwin I. 15	
Heintz & Kaufman, Ltd. 12	
Isolantite, Inc. . . . Inside Front Cover	
King Lab's, Inc. 8	
Lenz Elec. Mfg. Co. 1	
Mallory & Co., Inc., P. R. 4	
McGraw-Hill Book Co. 13	
Mica Insulator Co. 15	
Muter Co. 10	

McGRAW-HILL PUBLISHING COMPANY, INC.,
330 WEST 42d STREET, NEW YORK, N. Y.

Branch offices: 520 North Michigan Ave., Chicago; 883 Mission St., San Francisco; Aldwych House, Aldwych, London, W. C. 2; Washington; Philadelphia; Cleveland; Detroit; St. Louis; Boston; Greenville, S. C. James H. McGraw, Chairman of the Board; Malcolm Muir, President; James H. McGraw, Jr., Vice-President and Treasurer; Mason Britton, Vice-President; H. C. Parmelee, Vice-President; Harold W. McGraw, Vice-President; B. R. Putnam, Secretary.

WESTON

POWER LEVEL INDICATORS

(DB Meters)

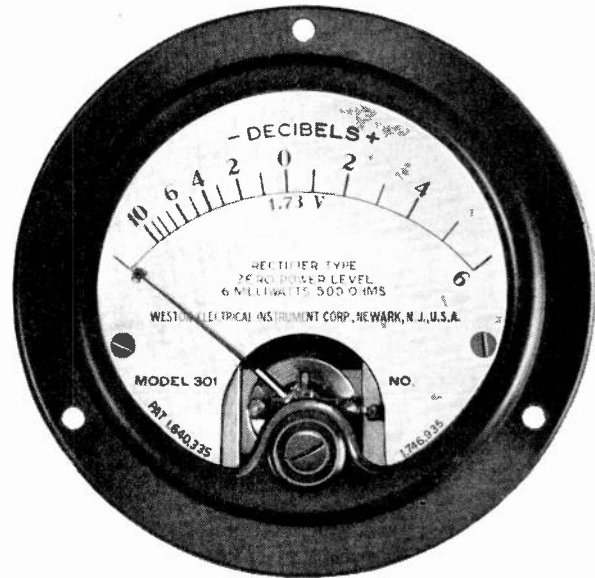

FOR maintaining the correct average level and the peak values below the distortion point in lines carrying voice or audio frequency currents, Weston now offers Model 301 Power Level Indicators in three types . . . high speed — general purpose — and slow speed.

These instruments normally are available adjusted to read either 0 or down 10 DB at 0 on the scale, based on a 6 milliwatt signal in either a 500 or 600 ohm line. The internal resistance is 5000 ohms for 0 DB or 1581 ohms for down 10 DB.

While the above specifications are standard for the 301 line, other instruments also are available for other levels, lines or resistances. Correspondence is invited on your requirements . . . Weston Electrical Instrument Corporation, 618 Frelinghuysen Ave., Newark, N. J.

WESTON

Instruments





1 NOISE TEST—This test, made in a shielded chamber that eliminates external interference, reveals defects in internal resistor structure that cause noisy resistors. The accurately controlled Allen-Bradley processes result in such uniformity that quiet resistors can be consistently guaranteed.



4 ALLEN-BRADLEY TESTS that guarantee resistor uniformity

Uniformity is a vital characteristic of good resistors. Only through uniformity can defective units be eliminated.

Moreover, uniformity of characteristics, such as the changes due to load, humidity, and long use permit designers to develop new receivers with the assurance that all sets delivered from the production line will be consistent in quality and performance, even after long use.

Allen-Bradley Resistors, made under continuous laboratory control, are of such exceptional uniformity that they are the choice of the leading manufacturers of fine receivers. Build quality into your receivers by specifying Allen-Bradley Resistors.

ALLEN - BRADLEY CO.
110 W. Greenfield Ave., Milwaukee, Wis.

2 LOAD CHARACTERISTIC—This test determines the effect of load and temperature on Allen-Bradley Resistors. Although resistance changes as high as 10% are tolerated by set manufacturers, Allen-Bradley units change less than 2% on low values and 3% on high values. Individual resistors adhere closely to these group values—erratic behavior is non-existent.

3 HUMIDITY TEST—This test, made after the R.M.A. method, determines the effect of moisture. Allen-Bradley limits of permissible resistance change are far below the usual limits, and in addition, Allen-Bradley Resistors vary consistently as a group. Individual resistors do not suffer erratic changes.

4 LIFE TEST—Continuous and cycle tests following R.M.A. methods are made at various loads as a check on the uniformity of Allen-Bradley Resistor performance under conditions which occur in radio receivers. In these life tests, Allen-Bradley Resistors demonstrate their stability in long service.



S. S. White

MOLDED RESISTORS



TYPE 16X—1 WATT

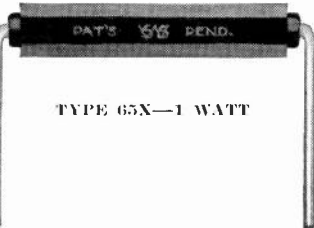

TYPE 65X—1 WATT



TYPE 25X— $\frac{1}{4}$ WATT



TYPE 10X— $\frac{1}{4}$ WATT



TYPE 15X—1.25 WATTS



TYPE 70X—2 WATTS

Above actual size illustrations show a few of the types available.

RESISTANCE RANGES

COMMERCIAL FIELD—

For the varied commercial purposes, Resistors are supplied in the standard range from 1,000 ohms to 10 megohms.

LABORATORY AND EXPERIMENTAL FIELD—

For this field, Resistors of the 65X type are supplied from stock, from a comprehensive assortment of unusually high values ranging from 10 megohms to 1,000,000 megohms. These high resistance units are commonly used with the FP54 Plotron tube, and are adapted for other electronic applications requiring resistance above the standard range. The NOISELESS operation of S. S. WHITE Resistors is of special importance in applications of this class.

Outstanding
in QUALITY
reasonable
in price

The name S. S. WHITE has become established as a symbol of quality. Every product which bears this name stands at the top in its class. S. S. WHITE Molded Resistors are no exception.

In the important element of NOISELESS OPERATION, S. S. W. Resistors are unequalled. Critical comparative tests prove this. Also they excel in mechanical strength, in durability, in the accuracy and permanence of their resistance values and in non-hygroscopic structure. They fully satisfy every essential resistor requirement. Yet they are very reasonably priced. It costs no more to use them and be sure of completely satisfactory performance and service.

It will pay all manufacturers and users of electronic, radio, laboratory and experimental equipment and all other devices in which resistors are employed, to do as many leaders in these fields have done after thorough tests—*standardize on S. S. WHITE Resistors.*

USERS INCLUDE

General Electric; Westinghouse E. & M.; RCA Telephone; RCA Communications, Inc.; U. S. Navy; Naval Research Laboratories; Pan American Airways, Inc.; International Broadcasting Equipment Co.; Automatic Signal Corp.; Carrier Microphone Co.; Leading University and Commercial Experimental Laboratories.

A TRIAL

INVARIABLY WINS ACCEPTANCE

•
DESCRIPTIVE CIRCULAR

and prices will be mailed on request. WRITE for it—today.



The S. S. WHITE Dental Mfg. Co.
INDUSTRIAL DIVISION
Knickerbocker Bldg.
New York, N. Y.

★ LOOK TO RCA ★

FOR ADVANCED METHODS OF RADIO TUBE MANUFACTURE



RCA RADIOTRON EQUIPMENT DEVELOPMENT DIVISION

These men develop, design, and fabricate most of the equipment used in RCA Radiotron factories. Long experience in the special problems of tube production, together with the most modern machine tools, makes this group unique in the radio tube industry. That their

watchword is PRECISION is exemplified by their scientific testing of materials, accurate methods of measurement, and microscopic inspection of parts. Only by such means can tube-making machinery be developed to produce quality radio tubes.

RCA RADIOTRON CO., INC.

HARRISON



NEW JERSEY