

electronics

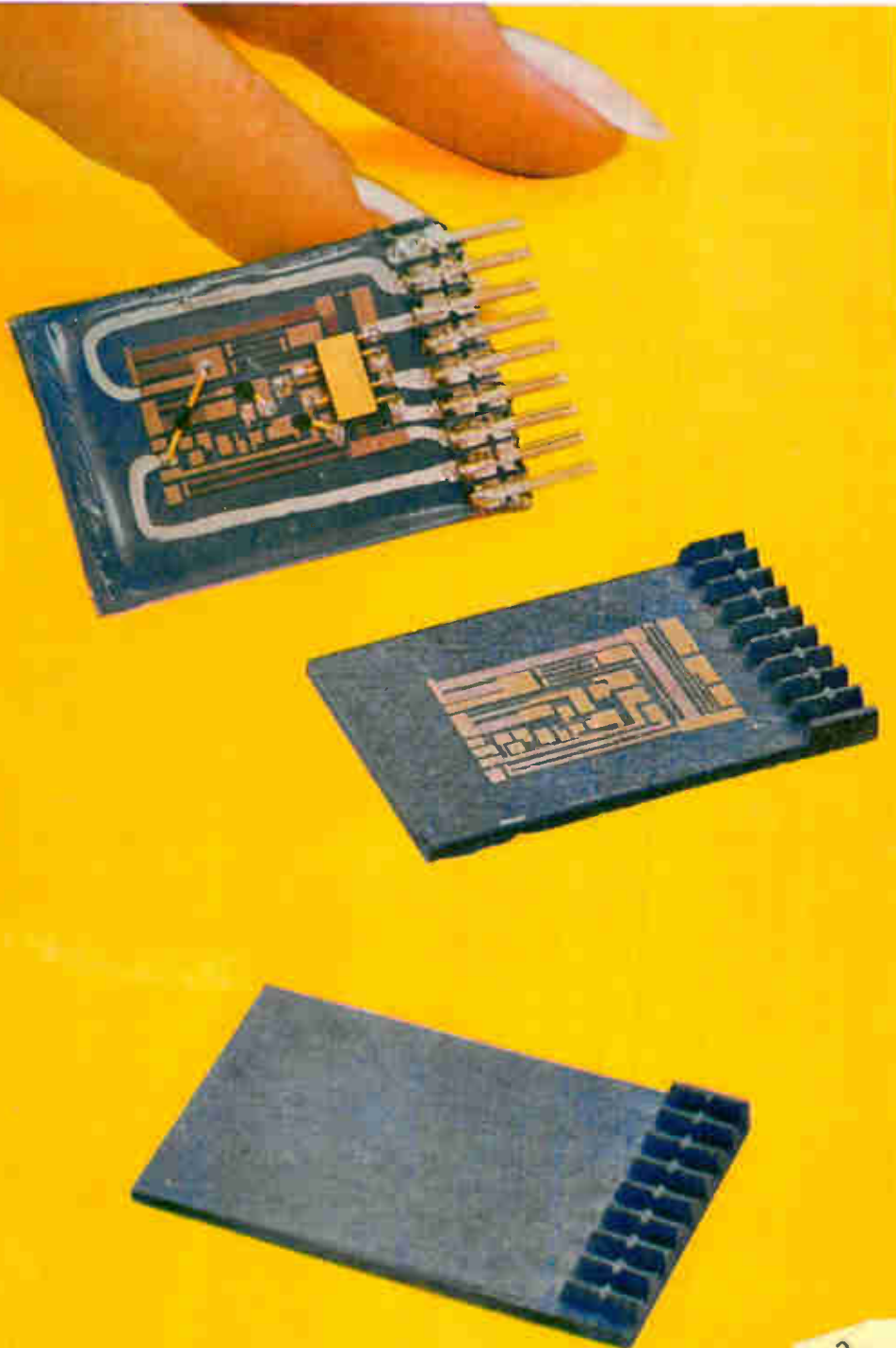

Ceramic substrate for thin films. It accepts thin films just like glass, makes interconnection problems fade

OPTICAL COUPLING

New way to stack microcircuit wafers

CODED PULSES FOR RADAR

More range for the same output power

CANADIAN NAVY TRAINER

Simulates antisub warfare tactics

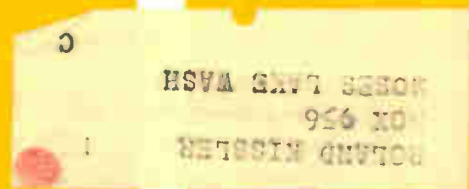

0
1
HSVA 3AV7 8880K
956 NO
ROLAND KISSLER



The **1151-A Digital Time and Frequency Meter** uses reliable all-solid-state ring-counting decades. No feedback is required, and consequently, voltage levels are not critical. Since the decade transistors operate simply as switches, full advantage is taken of their inherent reliability.

The 1151-A has a full complement of input controls permitting selection of trigger level, ac or dc coupling, and sensitivities of 1 volt at 1 megohm or 0.1 volt at 100 kilohms. In addition to frequency measurements and counting over a range of dc to 300 kc, the 1151-A will also measure periods to 20 kc and frequency ratios. Accuracy is ± 1 count \pm crystal oscillator stability. Short-term oscillator stability is better than $\frac{1}{2}$ ppm. Readout is provided by easy-to-read, bright, in-line Numerik indicators. Two models are available: the Type 1151-A, \$1195, and the Type 1151-AP which has outputs to drive an auxiliary Data Printer or a Digital-to-Analog Converter, \$1250. Also available is the 1150-A at \$995, to measure frequency only.

Digital Recording — The 1137-A Data Printer provides the means for recording decimal coded information from the 1151-AP. The Printer has a 5- to 12-digit capacity and operates at printing rates up to 3 prints per second. Price, bench model, \$1350; rack model, \$1400.

Analog Recording — The Type 1136-A Digital-to-Analog Converter translates the counter's digital output into a dc voltage or current for analog recording with 1-ma recorders. The converter selects any three consecutive or the last two digits from an input of up to nine columns. Conversion rate is up to 10,000 conversions per second. Output is 1 ma or 100 mv. Price is \$810, including Adaptor Cable with diode-matrix for connection to counter.

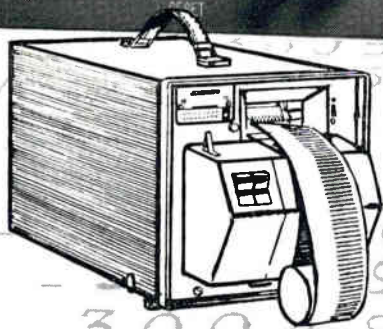
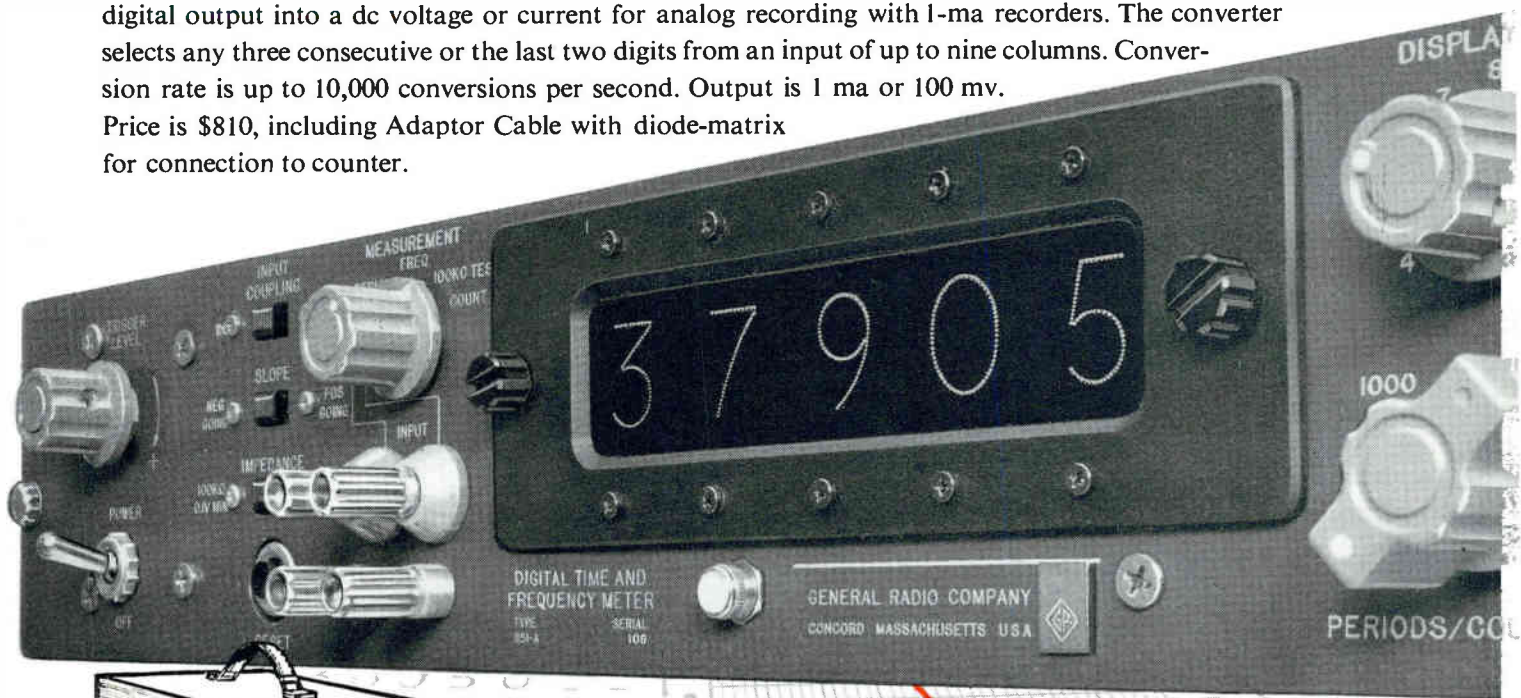

Openings exist for permanent positions in Development and Sales of commercial instruments. If interested, write M. A. Nacey.

IN CANADA: Toronto 247-2171, Montreal (Mt. Royal) 737-3673
IN EUROPE: General Radio Overseas, Zurich, Switzerland

GENERAL RADIO COMPANY
WEST CONCORD, MASSACHUSETTS

NEW YORK, N. Y., 964-2722
(Ridgefield, N. J.) 943-3140

CHICAGO
(Oak Park) 848-9400

PHILADELPHIA, 424-7419
(Abington) 887-8486

WASHINGTON, D.C.
(Rockville, Md.) 946-1600

SYRACUSE
454-9323

DALLAS
FL 7-4031

SAN FRANCISCO
(Los Altos) 948-8233

LOS ANGELES
469-6201

ORLANDO, FLA.
425-4671

CLEVELAND
886-0150

CIRCLE 900 ON READER SERVICE CARD

W. W. MacDONALD, Editor
Telephone Area Code 212 (971-2645)

J. M. CARROLL, Managing Editor (2293)

SENIOR EDITORS

Samuel Weber (2371)
George W. Sideris (3444)

SENIOR ASSOCIATE EDITORS

Michael F. Wolff (2600)
John F. Mason (2666)

ASSOCIATE EDITORS

Michael F. Tomaino (2071)
William P. O'Brien (2297)
George J. Flynn (2188)
George V. Novotny (3151)
Leon H. Dulberger (3446)
Alexander A. McKenzie (2685)

ASSISTANT EDITORS

Stephen B. Gray (2245)
Barry A. Briskman (2306)
Dan Smith (2467)
Joel A. Strasser (2127)
Vincent S. Acunto (2592)
C. R. Whetstone (3495)
Eric Valentine (2710)
Louis S. Gomolak (2472)

REGIONAL EDITORS

Harold C. Hood,
1125 W. 6th St., Los Angeles 90017, Calif.
(213-482-5450)
Laurence D. Shergalis,
John Hancock Bldg., 255 California St.,
San Francisco 94111, Calif. (415-362-4600)
Thomas Maguire
McGraw-Hill Bldg., 607 Boylston St.,
Boston 02116, Mass. (617-262-1160)
Cletus M. Wiley,
Blair Bldg., 645 N. Michigan Ave.,
Chicago 60611, Ill. (312-664-5800)

ART DIRECTOR

Howard R. Berry (2430)

ASSISTANT ART DIRECTOR

John C. Wright, Jr. (3430)

EDITORIAL ASSISTANTS

Lorraine Rossi, Virginia T. Bastian,
Lynn Emery, Ann Meila, Lorraine Werner,
Alice M. O'Brien, Sharon Parks,
Claire Benell, Kay Fontana,
Sandra A. Le Mond

FOREIGN NEWS BUREAU

DIRECTOR, John Wilhelm. (2532);
Lawrence Minton (2997), Alyne Elias
(2998)
LONDON—John Shinn, Derek Barlow,
Nicholas Landon, 34 Dover St., London
W.1, England
BONN—Bruce Bendow, Richard Mikton,
Silke McQueen, Mittelstrasse 39, Bad
Godesberg, Germany
BRUSSELS—27 Rue Ducarle, Brussels,
Belgium
PARIS—Robert Farrell, Arthur Erikson,
17 Ave. Matignon, 3rd Fl., Paris 8,
France
MILAN—Marc A. Messina, Via Manzoni
No. 12, Milan, Italy
MEXICO CITY—Wesley Perry, Jr.,
Lafragua 4-314, Mexico 1 D.F. Mexico
RIO DE JANEIRO—Leslie Warren, Rua
Mexico 3-S/1507 1509, Rio de Janeiro,
Brazil
MOSCOW—Stewart Ramsey,
Kutuzovskiy Prospekt 19, Apt. 28-29,
Moscow, USSR
TOKYO—Richard Halloran, Charles Cohen,
John Yamaguchi, Toranomon Sangyo
Bldg., 1 Kotohiracho Shiba, Minato-Ku,
Tokyo, Japan

CIRCULATION MANAGER

Hugh J. Quinn (2310)

C. C. RANDOLPH, Publisher (2016)

electronics

A MCGRAW-HILL WEEKLY 75 CENTS

CERAMIC SUBSTRATE IMPROVES MICROCIRCUIT RELIABILITY. Vitrified ceramic substrate formed from a compound of aluminum oxide holds its tolerance within one mil. *Amphenol component will accept thin-film vacuum depositions comparable to those now laid down on glass. See p 51* COVER

ARMY SKY FORCE. Army is moving ahead with its plan to gain mobility and striking power with air assault divisions. *Now in R&D are the equipments Army will need, including navigation aids, air traffic control, and flight and landing instruments* 10

SONAR NAVIGATOR. Four-headed doppler sonar in new system plots ship's course on navigational chart. *Navy has ordered two of these sea-going versions of airborne doppler navigators* 14

SPACE FREQUENCIES. International Telecommunications Union has allocated a wide range of frequencies to space communications. *Total frequencies amount to 15 percent of the radio spectrum* 14

OPTICAL COUPLING: NEW APPROACH TO MICROCIRCUIT INTERCONNECTIONS. When silicon microcircuit wafers are stacked in a module, interconnection using conventional means becomes extremely difficult. An alternative method is to use optical coupling. *Optical actuation of a microcircuit flip flop has been shown using a gallium-arsenide diode and an arsenic-trisulfide light pipe 1/2-inch long.*
By M. A. Gilileo and J. T. Last, Amelco Semiconductor 23

DIGITAL CORRELATOR DETECTS VOICE FUNDAMENTAL. In speech bandwidth compression using vocoder techniques it is necessary to determine vocal-cord vibration frequency from a signal whose fundamental has been removed by filtering. *This pitch detector uses digital correlation filters and operates in real time on clipped speech data.*
By R. B. Stone and G. M. White, General Electric 29

USING MICROCIRCUITS IN HIGH-RESOLUTION RANGE COUNTERS. This range counter operates at 150-Mc clock rate giving ± 1 -meter resolution. To conserve space and power, the high frequency portion of the counter is a microcircuit. *Snap-off diodes used in the driver help produce 2-nanosecond pulse widths.*
By L. C. Drew, Radio Corp. of America 31

HOW CODED-PULSE TECHNIQUES EXTEND RADAR RANGE. Simple radar systems are limited in performance by their level of radiated power, pulse length and beamwidth acquisition time. This system employs coded-pulse techniques to achieve long-range performance. *It uses a wide transmitted pulse at low rep rate, gains resolution by phase modulating the pulse carrier.*

By T. Sakamoto, Y. Taki, H. Miyakawa and H. Kobayashi,
Univ. of Tokyo

T. Suzuki, Univ. of Electrical Comm.

T. Yoshida, T. Takeya and M. Kokubu, Toshiba Electric 34

Published weekly, with Electronics Buyers' Guide as part of the subscription, by McGraw-Hill Publishing Company, Inc. Founder: James H. McGraw (1860-1948).

Title © registered U.S. Patent Office; © copyright 1963 by McGraw-Hill Publishing Co., Inc. All rights reserved, including the right to reproduce the contents of this publication, in whole or in part.

Executive, editorial, circulation and advertising offices: McGraw-Hill Building, 330 West 42nd Street, New York, N. Y., 10036. Telephone Area Code 212 971-3333. Teletype TWX N. Y. 212-640-4646. Cable McGrawhill, N. Y. PRINTED IN ALBANY, N. Y.; second class postage paid at Albany, N. Y.

OFFICERS OF THE PUBLICATIONS DIVISION: Shelton Fisher, President; Vice Presidents: Joseph H. Allen, Operations; John R. Callahan, Editorial; Ervin E. DeGraft, Circulation; Donald C. McGraw, Jr., Advertising Sales; Angelo R. Venezian, Marketing.

OFFICERS OF THE CORPORATION: Donald C. McGraw, President; Hugh J. Kelly, Harry L. Waddell, L. Keith Goodrich, Executive Vice Presidents; John L. McGraw, Treasurer; John J. Cooke, Vice President and Secretary.

Subscriptions are solicited only from those actively engaged in the field of the publication. Position and company connection must be indicated on orders. Subscription rates: United States and Possessions and Canada, \$6.00 one year, \$9.00 two years, \$12.00 three years. All other countries \$20.00 one year. Single copies, United States and Possessions and Canada 75¢. Single copies all other countries \$1.50.

THE PUBLISHER, UPON WRITTEN REQUEST TO OUR NEW YORK OFFICE FROM ANY SUBSCRIBER, AGREES TO REFUND THAT PART OF THE SUBSCRIPTION PRICE APPLYING TO COPIES NOT YET MAILED.

Subscribers: Please send change of address notices, subscription orders or complaints to Fulfillment Manager, Electronics, at the address below. Change of address notices should provide old as well as new address, including postal zone number if any. If possible, attach address label from recent issue. Allow one month for change to become effective.

Postmaster: Please send Form 3579 to Fulfillment Manager, Electronics, P. O. Box 430, Hightstown, New Jersey, 08520.



Audited Paid Circulation

Contents continued

EASY-TO-USE CHART FOR VSWR. Conventional methods for determining voltage-standing-wave ratio are time consuming and subject to error. This method requires only a knowledge of operating frequency, shunt resistance and equivalent shunt capacitance. *You need only a straight-edge and an r-f bridge with the shunt inductance in the unknown leg.*
By G. Hagn and B. Sifford, Stanford Research Inst. 38

ASW SIMULATOR. New training system developed for the Canadian Navy simulates antisubmarine warfare. *Computer-controlled displays allow CIC plotters of an entire asw task force to practice detecting, tracking and attacking submarines* 40

NUMERICAL CONTROL. Magnetic drum in its data-processing unit allows numerical control system to handle different tools. *This new system is aimed at an American market expected to grow to \$120 million in 1967* 41

CUTTING MEMORY COSTS. Costs of large memories may be reduced to 0.3¢ per bit by sandwiching thin-film elements deposited and etched on glass strips. *Developer's goal is a capacity of 1 million 36-bit words and a cycle time around 1 microsecond* 44

DEPARTMENTS

Crosstalk. Voice of the Dolphins 5

Comment. Transistor-Radio Jammer. Gamma-Ray Laser 6

Electronics Newsletter 17

Meetings Ahead. National Telemetry Conference 18

Washington This Week. Defense Supply Agency Plans To Automate Components Procurement 20

Research and Development. Communicating with Dolphins 46

Components and Materials. Ceramic Substrate Improves Microcircuit Reliability 51

Production Techniques. Multi-Frequency Transducers Improve Ultrasonic Cleaning 54

New Products. Comparator Has Large Error Expansion 58

Literature of the Week 62



People and Plants. Space-General Expands 64

Index to Advertisers 68

New from Sprague!

WORLD'S FASTEST

SYMMETRICAL PNP SILICON TRANSISTORS

 TO-5 actual size	2N2968	 TO-18 actual size	2N2969
	2N2970		2N2971

CHECK THESE FEATURES!

CHARACTERISTICS	2N2968 2N2969	2N2970 2N2971
BV_{CBO} & BV_{EBO}	30V	30V
I_{CBO} & I_{EBO}	0.01 μ A	0.01 μ A
h_{FE} & h_{FC}	15	10
f_{T1} & f_{T2}	10mc	8mc

Available in both TO-5 and TO-18 packages, these transistors are specifically designed for use in bi-directional switching, chopping, multiplex, and analog circuits when both high forward and inverse gains are required. They can be used to switch or chop a-c signals with a ground reference, without the necessity of adding a d-c level to the input signal.

Sprague's new Symmetrical Silicon Transistors are manufactured by the highly automated silicon precision alloy transistor process utilized by Sprague for more than three years in the production of PNP silicon choppers, amplifiers, and switches.

• For application engineering assistance, write to Transistor Division, Sprague Electric Co., Concord, N. H. For technical data, write for Engineering Bulletins 31,169 and 31,171 to Technical Literature Service, Sprague Electric Co., 35 Marshall St., North Adams, Mass.

SPRAGUE COMPONENTS

TRANSISTORS
CAPACITORS
RESISTORS
MICROCIRCUITS
INTERFERENCE FILTERS

PULSE TRANSFORMERS
PIEZOELECTRIC CERAMICS
PULSE-FORMING NETWORKS
TOROIDAL INDUCTORS
ELECTRIC WAVE FILTERS

CERAMIC-BASE PRINTED NETWORKS
PACKAGED COMPONENT ASSEMBLIES
BOBBIN and TAPE WOUND MAGNETIC CORES
SILICON RECTIFIER GATE CONTROLS
FUNCTIONAL DIGITAL CIRCUITS



'Sprague' and '®' are registered trademarks of the Sprague Electric Co.

TWO NEW PULSERS FROM hp—WITH TWIN PERFORMANCE INNOVATIONS:



Custom-designed nanosecond pulses

With the hp 215A: Positive or negative pulses to 10 v into 50 ohms with rise and fall times less than 1 nsec. Width continuously adjustable to 100 nsec. Continuously adjustable internal triggering 100 cps to 1 mc, external 10 cps to 1 mc, with selectable slope and level, single pulse. Trigger output 140 nsec advance to 10 nsec delay with respect to output pulse. Pulse bursts with gated input, 1 v to turn on. Price, \$1875.

Controlled, specified pulse shape! No need to monitor the pulse from this new generation of Hewlett-Packard pulsers. Pulse shape is so carefully controlled that it can be specified under all operating conditions!

Constant 50-ohm source impedance absorbs reflections from the external load, bans secondary reflections from the pulser. Monitoring is unnecessary.

Scope-type triggering, pulse gating. No amplifiers or inverters needed for external triggering—you can select your external trigger slope and level. The gated feature provides pulse bursts for maximum versatility!

Data subject to change without notice. Prices f.o.b. factory.

HEWLETT-PACKARD COMPANY

1501 Page Mill Road, Palo Alto, Calif. 94304, (415) 326-7000.
Sales and service in all principal areas. Europe, Hewlett-Packard S.A., 54 Route des Acacias, Geneva, Switzerland; Canada, Hewlett-Packard (Canada) Ltd., 8270 Mayrand St., Montreal, Que.



8691

Power-packed 200 watt pulses

With the hp 214A: Positive or negative pulses to 100 v into 50 ohms (2 amps) at rep rates to 1 mc. Rise times 10 to 15 nsec. Pulse width continuously adjustable to 10 msec. Internal triggering, 10 cps to 1 mc continuously adjustable, external, dc to 1 mc, level and slope selectable. Gated feature for pulse bursts, double pulse, single pulse, square wave capabilities. Ideal for high current applications. Price, \$875.

Ask your Hewlett-Packard field engineer for a demonstration of the pulse generator that will best fit your requirements.

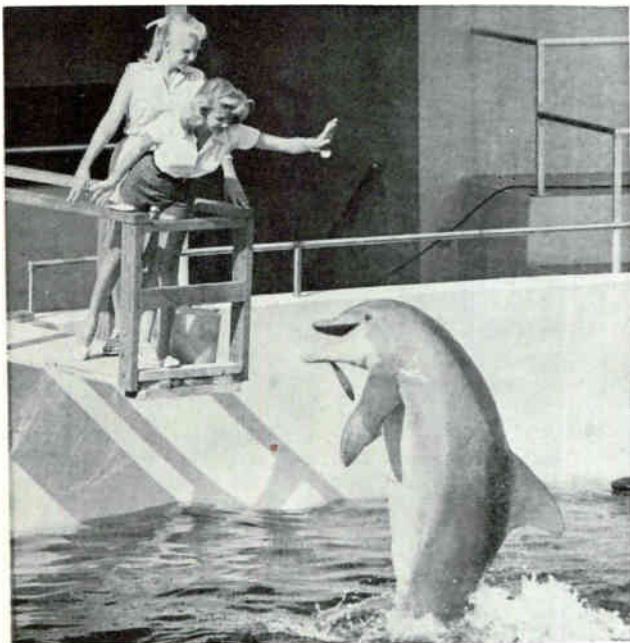

Voice of the Dolphins

SOME YEARS AGO, we read an intriguing book by physicist Leo Szilard. In "The Voice of the Dolphins," mankind establishes contact with the dolphin race and eventually uses the animal's high intelligence to solve human problems on a sort of consulting basis. Inspired perhaps by Szilard's speculation, science-fiction writers have assigned dolphins tasks like managing meat-and-milk whale herds in a future world where an immense human population depends heavily on the oceans' food resources.

Before too long, books about man's partnership with the dolphin may go onto library reference shelves, not into the science-fiction corner.

Research into the ways of the dolphin indicates that dolphins *could* do work for man—for example, performing oceanographic measurements or collecting samples of marine life. The Navy, apparently, would like to enlist dolphins, for Navy is sponsoring research on dolphins.

Dolphins are trainable; one scientist has estimated that *Tursios Truncatus* has an I.Q. around 190, transposed to a human scale. Dolphins talk to each other and can mimic human phrases. They are particularly fond of watching their own voices displayed on an oscilloscope.

The problem is that dolphins and humans don't understand each other's language. We need a human language-dolphin language dictionary. This is where electronics comes in.

An answer to the dictionary problem was offered this week in Baltimore, at the Electronics in Biology and Medicine Conference sponsored by the IEEE

and ISA. Using an intricate fiber-optic device called the Sceptron (see p 46), scientists at Sperry and the Communications Research Institute are translating dolphin sounds into light patterns meaningful to humans, thus providing a key that might permit humans to imitate dolphin talk, and vice versa.

The authors propose a training device based on the Sceptron. One of its "black boxes" would do what the young ladies in the photo are doing, reward a dolphin with a mackerel for performing a task. Whether dolphins are so human they would resent the substitution is something that remains to be seen.

PLENTY OF ROOM FOR SPACE. The last time the International Telecommunications Union revised its table of frequency allocations was in 1959. At that time, space communications were granted only about one percent of the allocated spectrum.

During the five-weeks-long meeting of the ITU, which ended two weeks ago in Geneva, the delegates of some 70 countries agreed to allocate about 15 percent of the spectrum to space uses—an obvious testimony to the importance of space communications and scientific projects, especially since many of the nations represented do not yet have active space programs.

Experts at the meeting believe that the frequencies granted, totaling some six million megacycles (see table, p 14), will be sufficient for the unhindered development of space electronics for the next 10 to 12 years.

Coming In Our November 29 Issue

VOTES FOR COMPUTERS. In conventional logic systems, which generally depend upon the simultaneous arrival or absence of inputs to a logic element, one faulty gate can cause a failure in the logic train.

Partly because of this reliability problem, and partly because of other design advantages, more and more attention is being paid to majority and threshold logic concepts. Majority-logic elements aren't particularly concerned whether every input is or is not present—they vote on whether a majority of an odd number of inputs are present. The broader subject of threshold logic is of major importance for adaptive circuits.

Next week, in an important article, W. A. Sauer, of GE, discusses several approaches to the design of solid-state majority and threshold logic circuits, including ways to reduce the number of circuits in conventional applications for logic systems.

Other feature articles next week include:

- Microsecond data display. Because this system can produce 12 displays and write 50,000 characters a second, it can keep up with on-line data processors.
- Conical scan array with variable phase shifters. The antenna and feed design simplify a monopulse automatic tracking system.
- Technique for converting conventional single-trace oscilloscopes to raster displays.
- Discriminator that uses R-C networks instead of tuned circuits to measure f-m.

**EXCEPTIONALLY
STABLE
WAVEFORMS**

**EVEN AT 5,000 MC,
TRACES ARE UNMARRED
BY DOT-SPLATTER**

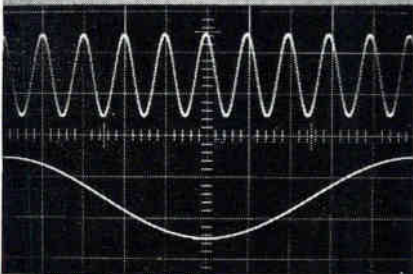

Unique triggering stability of Analab Type 701 plug-in demonstrated by display of 5,000-mc sine wave. Bottom trace shows same waveform expanded 10:1 (a double exposure).



Analab Type 1120R/701 sampling oscilloscope (rack mounting). Also available as portable scope.

ONLY WITH

Analab

**SAMPLING
OSCILLOSCOPES**

using the completely transistorized
TYPE 701 sampling and sweep plug-in

Now, with the new Analab scope system, you can obtain signal-repetition rates to 5,000 mc and over, without external pre-trigger signals, countdown generators, or delay lines. Waveforms can be plotted with slaved x-y recorder, or stored indefinitely on the Analab storage scope (type 1220/701). The most undistorted deflection, brightest displays obtainable on any high-frequency oscilloscope.

Type 701 plug-in features:

- Built-in trigger circuits with one-knob control...triggers directly from the signal.
- Built-in sweep circuits, sweep ranges from 10 picoseconds/cm to 2 micro-seconds/cm.
- Built-in direct-coupled dual-channel amplifiers, nominal risetime 350 picoseconds.

Write or phone for complete technical data and demonstration.

**Analab Instrument
Corporation**

Cedar Grove, N. J. • (201) 239-6500

TRANSISTOR-RADIO JAMMER

To relieve your mind about the *Crosstalk* item, Countermeasures Again (p 3, June 21), it's entirely possible that some of the "jammers" built by me found their way to England. Some thirty or so have been built to date and I know of at least twelve that went to England, France and the U. S.

The original was built as a favor for a friend who was bothered by a Spanish neighbor who kept Spanish hours whereas my friend kept American hours. It bothered my friend very much to have the Spaniard turn on his radio next door from 10 p.m. to 4 a.m. Friend also noted that the jammer was very effective against transistor portables (the status symbol among the middle and lower-class Spanish is to carry one—ON full blast—this is bad when you're trying to "eat out"—and my friend is a bachelor!).

One thing led to another, so now the "standard" model is about 60-70 mw output, tunable over broadcast band, with on-off switch. Size is about ¾ by 1½ by 2½ inches, using one 9-volt battery and one transistor.

The "big job" is about 500 mw output and is 4¼ by 6¼ by 7/8 inches, using pen-lite cells, and will blank out any local station to which it is tuned.

Am trying to develop one that uses a Varicap plus sawtooth generator to sweep the broadcast band, thus doing away with the necessity of seeking out the station to which the offending radio is tuned. Problem: extra cost of parts.

Might say that the "big job" does not give the owner of the offending radio any idea of what happened (this has been observed): the owners usually bang their radios around a little, try another station (which soon squeals a little and then goes dead), then turn it off with the remark that they must get it fixed!

It has been observed that some of the "better" restaurants have "somehow" failed to repair "leaky" neon signs, even to the point where some have neon-sign transformers plus a wire around the dining room and a crude spark gap—strictly accidental, you understand.

I'd prefer you didn't use my name—I have enough business as it is.

(NAME WITHHELD)

Madrid, Spain

- That *Crosstalk* item concerned a rumor that someone in England had developed a jammer that could be used against portable transistor radios played too loudly in public. We had asked our London office to check on it, and the answer was that the jammers were not in production there, and no one was using them. Their use would be illegal, as in the U. S.

GAMMA-RAY LASER

I read with interest your article, Russia Tries Gamma-Ray Laser, on page 11 of the Oct. 4 issue. You state that the Russian Scientist, B. V. Chirikov, has invented a gamma-ray maser. I should like to point out that the idea of a gamma-ray maser was conceived by V. Vali and W. Vali quite some time ago in this laboratory and our claim is fully documented as follows:

- (1) Internal document—Gamma-Ray Maser, 1960
- (2) B.S.R.L. Progress Review—First Six Months of 1961, and following Progress Reviews.
- (3) Patent application—Simulated Gamma-Ray Emission, the Boeing Company, 1961.
- (4) Induced Gamma-Ray Emission, by V. Vali and W. Vali, *Proc IEEE*, 51, pp 182-184, Jan. 1963.
- (5) Induced Gamma-Ray Emission, by V. Vali and W. Vali, presented at the Third International Conference on Quantum Electronics, Paris, France, Feb. 11-15, 1963.
- (6) Reply to comments on "Induced Gamma-Ray Emission" by V. Vali and W. Vali, *Proc IEEE*, 51, pp 1247-48, Oct. 1963.
- (7) Induced Gamma-Ray Emission II, by V. Vali and W. Vali, submitted for publication in *Proc IEEE*.

Furthermore, Chirikov concerns himself mainly with the kinetics of the induced emission, while the articles by V. Vali and W. Vali deal with the conditions that must be satisfied to make the process observable. These conditions are similar to the Schawlow and Townes conditions for lasers, with some modifications characteristic to processes dealing with gamma-ray emission.

You might be further interested to know that during the past three years, V. Vali and W. Vali have approached with vigor an experimental program to demonstrate the feasibility of this idea. After this work appeared in the open literature, a number of organizations including the USAF and the USN have become intensely interested in this principle.

I am sure you will agree that our claim considerably predates that of the Russian's. . . .

T. E. TURNER

Boeing Scientific Research Laboratories
Seattle, Washington

NANOSECOND PULSE FROM NEW RAULAND ULTRAFAST SCAN CONVERTER STORAGE TUBE

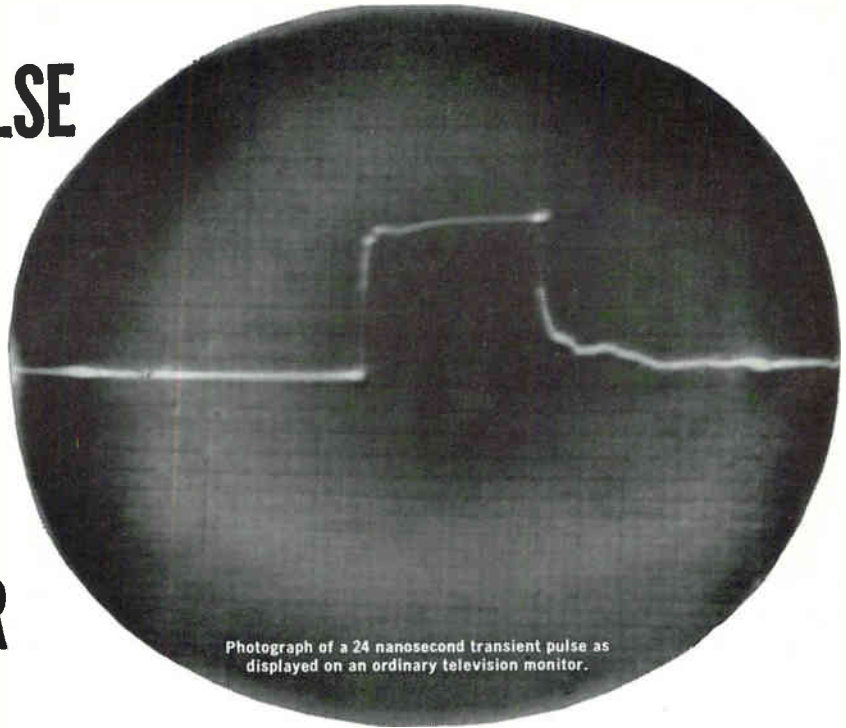

Photograph of a 24 nanosecond transient pulse as displayed on an ordinary television monitor.



Rauland has developed an ultrafast Scan Converter Storage Tube that records and stores transient phenomenon with pulse rise times in the range of a nanosecond or less. The unique design of the new Rauland R6253 tube permits slow scanning techniques to be used for the relay of transient pulse data over narrow band systems of 100 KC bandwidth or less. The pulse may also be recorded by conventional means—on magnetic tape, transmitted over inexpensive telemetry links, over communication cables, displayed on an ordinary television monitor and photographed using “box camera” exposure time. When displayed on a monitor, the tube

further allows unaided visual observation of extremely fast phenomenon for a period of several seconds. Relay or recording of pulses can be simultaneous with visual observation. The tube, consisting of separate writing and reading electron guns, is approximately 27 inches long and is 4 inches at its largest diameter. It utilizes a distributed deflection system for the writing side and either magnetic or electrostatic deflection for readout of high speed phenomenon. The tube is available with characteristic impedances of 50 or 125 ohms. The deflection system, being a continuous transmission line, allows the operation of several tubes in series.



SCAN CONVERTER STORAGE TUBES

Resolution Capability of 1000 TV lines. Erase Capability of 2 seconds or less. Any combination of electrostatic or magnetic deflection is available.



FLAT FACE DISPLAY TUBES

Rauland's flat face tubes (16", 22", 24") minimize parallax error. Resolution capability of 1000 TV lines at a brightness of 100 foot-lamberts. We will suit your specific requirements with any type of radar display tube in any size with any type phosphor or gun.



HIGH-RESOLUTION, HIGH-BRIGHTNESS TUBE

Round 21" high voltage CRT will resolve at least 1000 TV lines at a brightness of 300-500 foot-lamberts. For displays under high ambient light conditions. Write or phone...



The RAULAND Corporation

5600 JARVIS AVENUE
CHICAGO 48, ILL.
MULberry 5-5000

A subsidiary of



Radio Corporation
Chicago, Illinois

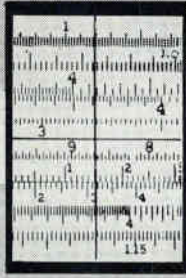

P. R. MALLORY & CO. Inc.
MALLORY

P. R. MALLORY & CO. INC., INDIANAPOLIS 6, INDIANA

Choosing high-energy battery systems

The variety of high-energy primary battery systems which Mallory has developed makes it possible to engineer characteristics of convenience, miniaturization and dependability into self-powered products. The mercury and manganese systems, in particular, have applications in many industrial, commercial and consumer products. Here are some brief facts on how they compare with conventional batteries.

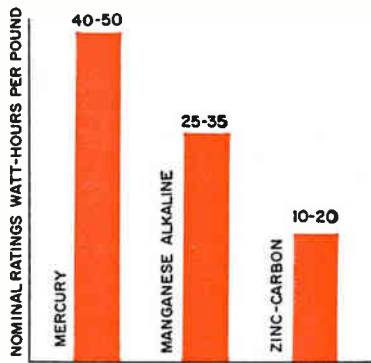

Energy per pound. Compared with the familiar zinc-carbon system, the Mallory manganese battery delivers about twice as many watt-hours per pound; the Mallory mercury system about three times as many. The mercury system is thus preferable for uses requiring maximum energy in minimum size.

Service life. Because of its higher energy content, the mercury system can deliver considerably longer life, especially when operated at moderate to light drains. The manganese system is most economical in heavy-duty service. The chart shows typical comparative life curves for these systems compared with zinc-carbon. Note that the mercury battery discharges at constant voltage. This quality makes it especially useful in transistor circuits. In the example shown, the manganese battery outlasts zinc-carbon by three to one; the mercury system outlasts it by better than four to one.

Mallory self-holding resonant relays cut costs in tone-operated switching

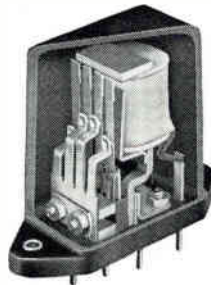

The Mallory Self-Holding Resonant Relay is a unique kind of tone-actuated, snap-action switch. It responds only to a signal of proper frequency, power level, and time duration. It has high inherent discrimination against false operation of sub-marginal and transient signals—without need of auxiliary filters or other rejection circuitry. Selective closing of remote circuits is accomplished by the transmission of audible tones to these relays

over any carrier that is capable of handling voice transmission without frequency distortion.

The resonant reeds are "self-held" in the unoperated position by a permanent magnet. This provides reasonable resistance to shock and vibration and prevents contact action until proper signal is received. Relay operation to close contacts is fast and chatter-free.

The relay reeds and circuits are "self-held" in the operated position by a simple external circuit involving a series and a shunt diode. Since there is no vibration or arcing of the contacts, connected loads

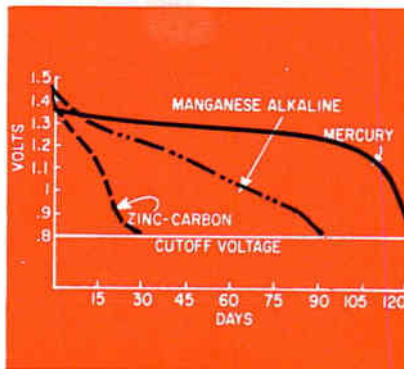

Storage life. Both the mercury and the manganese systems have unusual retention of capacity when left idle for long periods of time. Capacity loss is in the order of a few per cent per year. We have had mercury cells in storage for over 12 years which still show appreciable energy remaining.

Mallory high-energy systems are available in special constructions to fit your specific requirements, as well as in standard cell designs.

CIRCLE 240 ON READER-SERVICE CARD

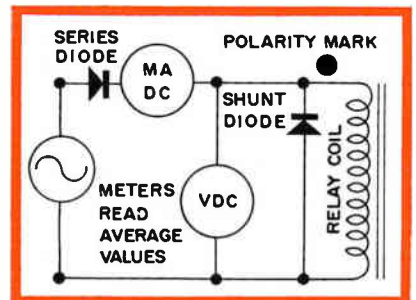

up to 2 amperes may be handled directly. This eliminates the need for a DC power source, a storage capacitor, and a sensitive auxiliary relay, as is commonly required in plain resonant reed circuitry.

The frequency response of the self-held resonant reeds is purposely made ± 3 cycles wide around the resonant value. This makes it possible to use a simple and inexpensive tone generator such as a multivibrator circuit without concern about changes in exact frequency caused by temperature or minor voltage changes.

We invite you to examine the possibility of using these unique devices in selective calling systems, remote controls, security circuits, and telemetering devices.

CIRCLE 241 ON READER-SERVICE CARD

DESIGNER'S FILE

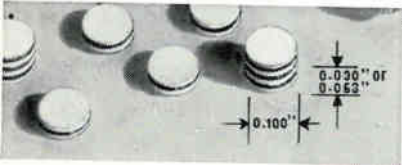

Need a tiny resistor with zero inductance?

In an RF circuit, it doesn't take much of a resistor to give you inductance problems. With Mallory pellet film resistors, we can give you a microminiature package and practically zero inductance at frequencies in the UHF range.

These tiny resistors are only 0.100" in diameter. Thickness is 0.030" or 0.063"; the smaller size comes in resistance values from 10 to 500,000 ohms, the larger in values up to 2½ megohms.

Stability is excellent. Reliability is high: no catastrophic failures have occurred in over 1 million piece-hours of testing.

We can supply these resistors from current production. We also have many suggestions concerning methods of interconnection in microminiature circuits.

CIRCLE 242 ON READER-SERVICE CARD

Miniature 5-watt wire-wound controls



Smallest commercial wire-wound control, the Mallory Type VW is only ¾" in diameter, yet it's rated at 5 watts at 35°C ambient. It can be used at high ambients, by derating linearly to zero at 105°C. Depth behind panel is only ¼". It has a ⅜" bushing length and ¼" diameter shaft. A companion model is

Report on reliability: XT tantalum capacitors proved by 10,260,000 piece-hours of testing

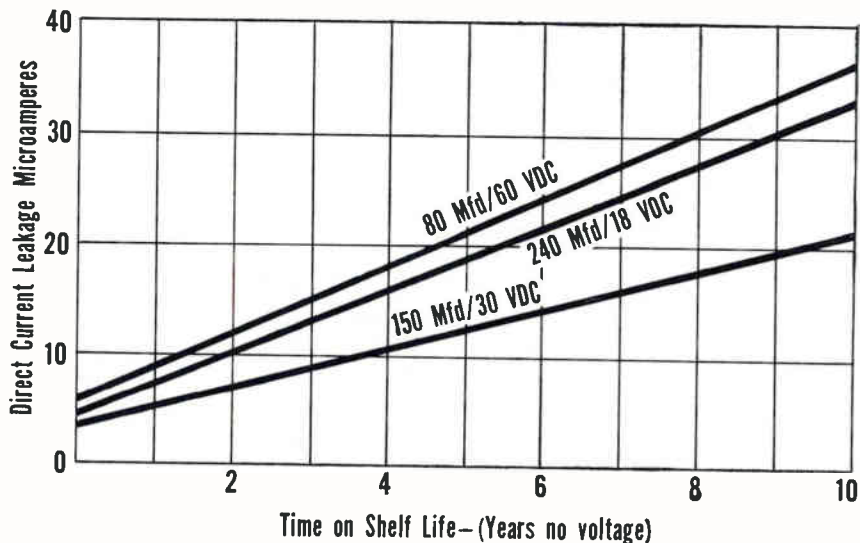

During the nearly 15 years that we have been making XT capacitors, we have gathered an impressive amount of data on their reliability. Some of this came from our own tests, some from independent laboratories, and some from military equipment manufacturers. The results speak for themselves.

Standard production capacitors to date have been given a total of 10,260,000 piece-hours of testing. Mean time between failure is presently 960,000 hours.

In independent two-year tests running 40,000 hours, XT capacitors have been proved to have twice the anticipated mean time to failure of other tantalum capacitors.

After ten years of shelf storage, Mallory XT capacitors still meet original specs for DC leakage (see chart above).

Seal tests by independent laboratories indicate that the leak rate of the XT hermetic seal is 1×10^{-11} standard cc. XT capacitors have been accepted for use in airborne military equipment.

The original high temperature wet slug tantalum capacitor, the XT series includes 175°C and 200°C ratings in many styles, including a wide range of MIL types. Our plant has been operating for the past five years under the Signal Corps RIQAP plan. Write or call for a copy of our most recent reliability data.

the Type SC, exactly like the VW except it has a ⅛" diameter shaft.

Both have been tested for rotational life of at least 10,000 cycles running at 20 cycles per minute. They will withstand shock, vibration and environmental exposure comparable to military requirements. Supplied in resistances from 1 to 25,000 ohms; linear taper standard, non-linear tapers on request. Standard tolerance is ±10%; closer tolerances on special order. Voltage breakdown tested at 900 VAC-RMS.

CIRCLE 243 ON READER-SERVICE CARD

CIRCLE 244 ON READER-SERVICE CARD



FOOT SOLDIER locates his position by same navigation system used by aircraft and ground vehicles. Low-frequency, hyperbolic system (AN/GRN-14) is built by Bendix-Pacific under license from Decca



PARACHUTIST can drop behind enemy lines with 37-pound radio command pack to direct air and ground operations (Sylvania)

Army Seeks Gear For Air

Tests continue on hyperbolic and doppler systems, landing and radar gear

By JOHN F. MASON
Senior Associate Editor

WASHINGTON—Equipment needs for Army's new air arm has moved one step closer to definition with completion of Phase I of the evaluation program for the 11th Air Assault Division and Transport Brigade at Fort Benning, Ga. One battalion of the new "sky soldiers" was trained in the use of equipment and general philosophy of this airborne fighting force.

Phase II, already underway, consists of training an entire brigade. Phase III, using a complete division, will begin next summer and continue through 1965.

Army's aviation program is already big and is expected to get much bigger. The ultimate size depends on current tests and the attitude of the Defense Department next year. Prospects for both look promising.

Efforts to solve Army's equipment problems (ELECTRONICS, p 32, April 12) are expected to increase as the program moves ahead. R&D work is underway on new gear for air traffic control, various types of navigation systems, poor-visibility landing, radio altimeters, terrain avoidance radar, and cockpit instrumentation. Work on sur-

veillance and armament will be discussed in a subsequent article.

Air Traffic Regulation—Control of large numbers of low-flying aircraft in or near battle areas will continue to be a big concern of Army planners for some time to come.

Army's Combat Development Command is now working on a statement of requirements for high-density ATR conditions for all Army aircraft. Moving from this formulative stage to usable equipment in the field will be a lengthy process.

To fill the gap, Army has an approved requirement for packaging an air terminal control facility. This facility will consist of space for the operators, standard Army communication equipment, and the scope and control portions of the AN/TPN-8 GCA (ground controlled approach) radar. This system will be used at division and other field army airstrips to provide a modest capability for handling IFR traffic.

Although Army has expressed no official interest, Air Force Commandos have just completed testing a 37-pound radio command pack in Southeast Asia that can be carried behind enemy lines by one parachutist. The unit then permits control of both aircraft and ground troops, and coordination with ground stations. Four transceivers cover frequency range from 38 to 350 Mc. H-f/ssb unit is used for point-to-point up to 500 miles; vhf/f-m to ground troops up to 25 miles; vhf/a-m and uhf/a-m are for

ground-to-air to 100 miles. Developer Sylvania has demonstrated the gear to Army's 11th Air Assault Division, Fort Benning, Ga.

R&D work is underway for improved equipment in all the major areas of airborne traffic control: navigation, instrumentation, identification and landing.

Navigation—Service testing of the Position Fixing and Navigation System (PFNS), designated AN/GRN-14 was completed this month at the Army Electronics Proving Ground, Fort Huachuca, Ariz. Report of the findings will now be sent to Test and Evaluation Command, then to Army Materiel Command, and then the Department of the Army. Air Force participated in the testing at Fort Huachuca. The equipment is built by Bendix-Pacific under license with Decca.

PFNS is a low-frequency, hyperbolic system. It provides position information by means of phase comparison of continuous wave signals from a set (usually four) of widely spaced radio transmitting stations. Received signals are converted to position information either by reference to an overprinted map or read directly on a special computer display.

One advantage of PFNS is its adaptability to use in aircraft, ground vehicles such as jeeps, and by troops carrying a 27½-pound manpack unit. The foot soldier can read off his position by two dial-type instruments and a special map. The battery powered receiver is low-

ARMY AIR DIVISIONS

An Air Assault division will consist of approximately 460 planes—28 fixed-wing Mohawk surveillance planes, and the rest helicopters. The light observation helicopter, LOH-13, is now being used, along with Bell's UH-1 Iroquois—Army has just ordered 700—and Boeing/Vertol's CH-47 Chinook.

Each ROAD division (reorganization of Army divisions) will require 103 aircraft each—97 rotary wing, and six fixed wing. Of the rotary wing, 48 will be the LOH and 49 the UH-1 Iroquois. Fixed-wing planes will consist of four Mohawks for surveillance and two utility aircraft

Traffic and Navigation

drain and transistor-operated.

Each of the four transmitters, separately housed in shelters, consists of two redundant sections to allow continuous transmission during maintenance periods. The transmitter provides 1,200 watts to a quickly erected antenna—106-foot high and pneumatically raised.

Other Navigation Systems — A Decca navigation system will be installed at Fort Benning, Ga. by Laboratory for Electronics under a \$1.9 million contract. Bendix-Pacific's PFNS receivers can operate in the Decca chain.

Another hyperbolic system, still classified, is now undergoing feasibility testing by the developer, Motorola, at their Phoenix plant. Although originally developed for drones, Army believes the system can be used in manned aircraft. Motorola's system is in an earlier stage of development than the PFNS.

Another possibility for a navigation system is Loran C. To date, commercial and some military airborne equipment has been built. Makers of the gear say, however, that lightweight receivers and transmitters can be built. Air Force has expressed interest in Loran C and may test it. If they do, Army will probably participate. Makers include Collins, ITT, and Sperry (ELECTRONICS, p 22, June 28).

Three doppler navigator systems, submitted by Ryan, Canadian Marconi, and GPL division of General Precision Aerospace, are now

being flight tested for comparative evaluation by the Army.

First requirement is for a doppler set for the fixed-wing Mohawk surveillance plane. Exact position is highly important for surveillance work for pinpointing sensor recordings. Doppler navigators for helicopters, which must function while the craft is hovering, are also being investigated. Ryan and Canadian Marconi are competing for a universal system to operate in both rotary and fixed-wing planes.

Navigation Aids—Radio altimeters

are also undergoing comparative evaluation by Army: Equipments being tested are supplied by Sperry, Bendix, Minneapolis - Honeywell, RCA, and Litton Industries' Radcom division.

Terrain avoidance radar (known also as "terrain following" and "forward-looking" radar) is being developed by Texas Instruments. One feasibility model has been delivered and two more are expected in April. Such equipment would be useful for the low-flying Mohawk, especially under poor-visibility conditions, and for helicopters flying "nap of the earth" at night.

Poor-visibility landing system for tactical zones is being investigated by RCA. Ideal system would use self-contained elements in aircraft with no equipment required on the ground.

Cockpit instrumentation development continues as part of the Joint Army Navy Aircraft Instrumentation Research program (Janair), formerly known as ANIP. Douglas has two contracts for instrumenting Army planes: one for rotary and one for fixed-wing. Demonstration models will be ready shortly.

The only imminent communications need Army has is for smaller, lighter ssb equipment, weighing less than 50 pounds. Technical characteristics are now being defined.

Ace High's Final Link Completed

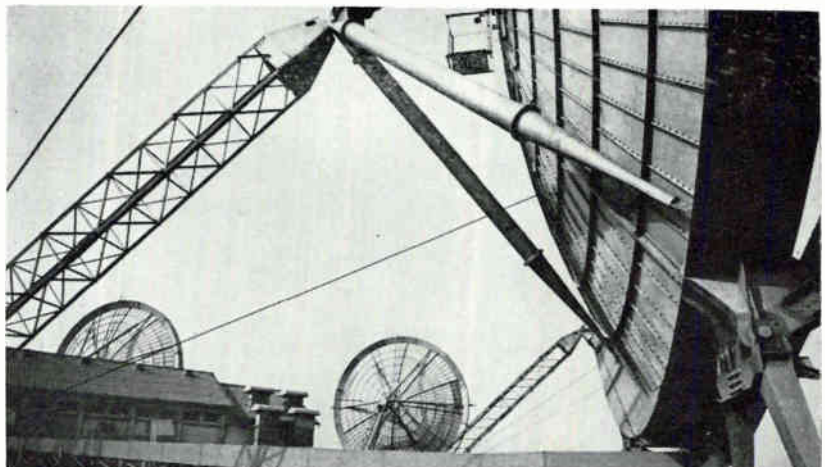

MASSIVE SUPPORTS form base of 60-ft troposcatter antenna serving Paris North, master control center for NATO's Ace High communications network extending 8,300 miles from United Kingdom to Turkey. Last station of group (operations began two years ago) was just accepted from International Standard Engineering, Inc., ITT affiliate. Backbone route provides 36 voice channels or up to 18 times that number of telegraph circuits

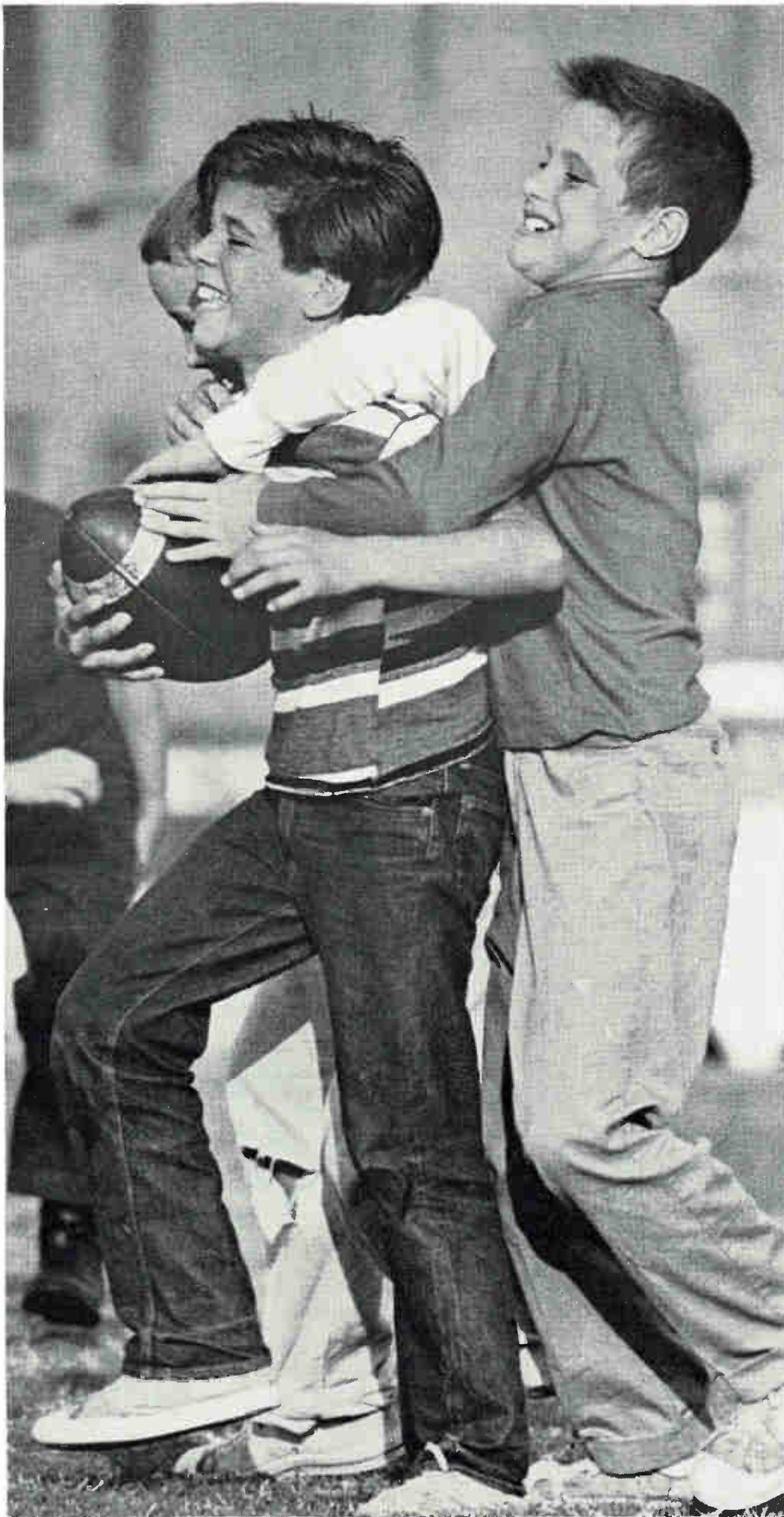

The men you hire tomorrow

are the kids you help today

Contributions made to United Funds or Community Chests are really an investment. An investment in *your* future. United Fund agencies take the edge off hunger and misery, sure, but they go way beyond that. They do an awful lot for youngsters—providing recreational facilities, finding homes for the homeless, steering puzzled teen-agers onto the right road. So it makes good sense to give the United Way. Your company can make a contribution, and you can make it convenient for your employees to join in through payroll payments. This once-a-year appeal cuts down on the confusion and duplication of separate drives, too. So give United. Could be, the kids you help today will be helping your business tomorrow.

**One gift works many
wonders/GIVE THE
UNITED WAY**

PHOTO BY PHIL BATH

4

TRACE

PREAMPLIFIER

for Tektronix
Oscilloscopes that
accept
letter-series
plug-in units

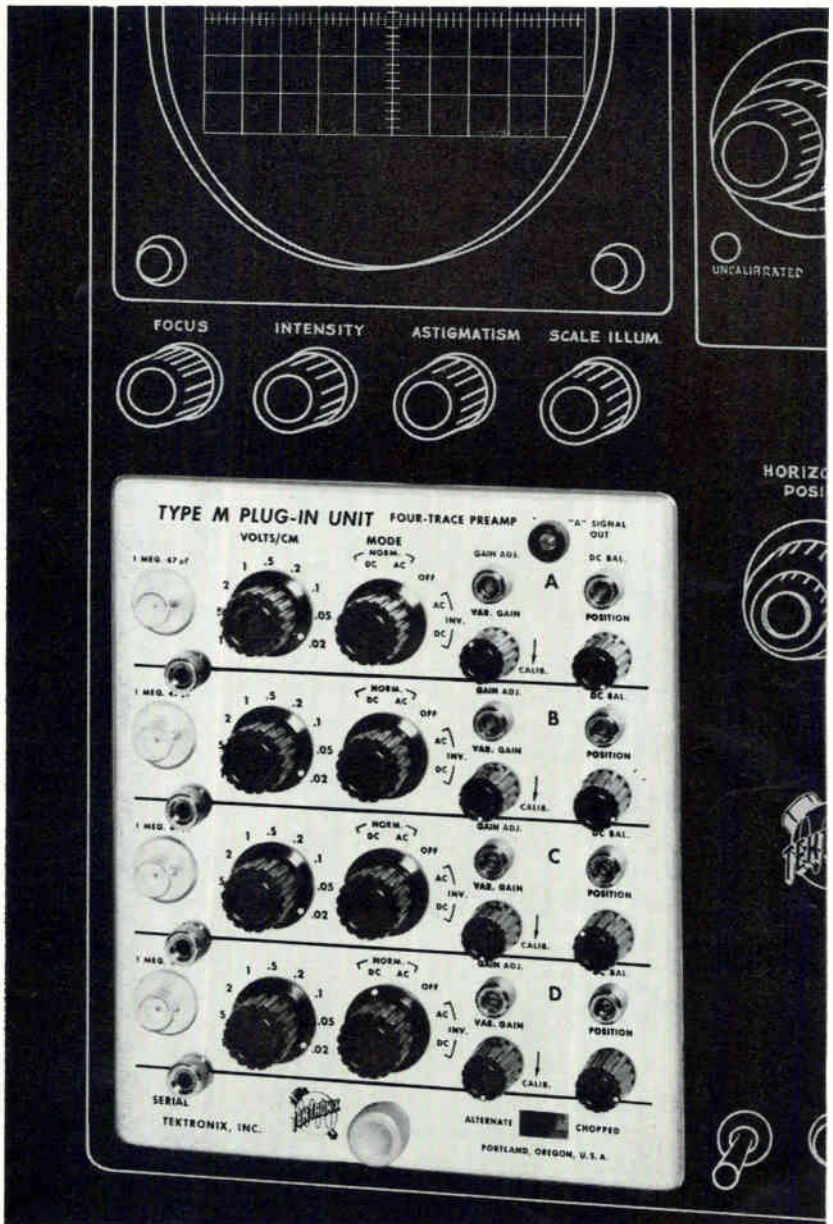
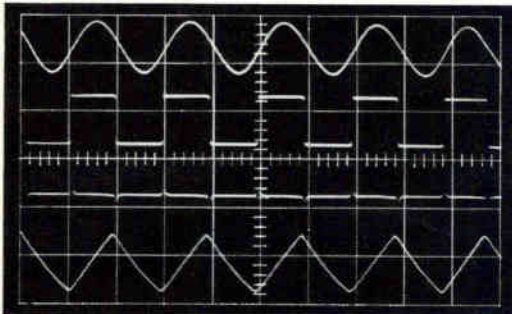

TYPE M UNIT adds multi-trace displays to the wide range of applications possible with your Tektronix oscilloscope.

With a Type M Unit, you can observe up to four signals—either separately, or in any combination.

Independent controls for each amplifier channel permit you to position, attenuate, invert input signals as desired.

Other convenient preamplifier features—such as triggered or free-running electronic switching . . . ac-coupling or dc-coupling . . . and, after initial hookup, little or no cable switching—ideally suit the Type M Unit for multi-trace presentations in the laboratory or in the field.

CHARACTERISTICS

Operating Modes—Any combination of one to four channels electronically switched at the end of each sweep or at a free-running rate of about 1 Mc (1 μ sec width samples). Or each channel separately.

Channel Sensitivity—20 mv/cm to 10 v/cm in 9 calibrated steps. Continuously variable uncalibrated between steps, and to 25 v/cm.

Channel A Signal—Available on front panel for optimum triggering in some applications.

Frequency Response and Risetime—DC to 20 Mc, 17 nsec, with fast-rise oscilloscopes.

Constant Input Impedance—At all attenuator settings.

Type M Plug-In Unit \$525.00

U. S. Sales Price f.o.b. Beaverton, Oregon

FOR A DEMONSTRATION, PLEASE CALL YOUR TEKTRONIX FIELD ENGINEER.

Tektronix, Inc. / P. O. BOX 500 • BEAVERTON, OREGON 97005 / Phone (Area Code 503) Mitchell 4-0161 • Telex: 036-691 • TWX: 503-291-6805 • Cable: TEKTRONIX • OVERSEAS DISTRIBUTORS IN 27 COUNTRIES

Tektronix Field Offices: in principal cities in the United States. Consult Telephone Directory • Tektronix Limited, Guernsey, Channel Islands
Tektronix Canada Ltd.: Montreal, Quebec • Toronto (Willowdale), Ontario • Tektronix Australia Pty. Limited, Sydney, New South Wales



SKIPPER and engineer aboard Raytheon's test boat watch pen trace course on chart

Doppler Sonar Plots Ship's Course

Movement over ocean bottom is recorded on navigation chart

By **THOMAS MAGUIRE**
Regional Editor, Boston

NEWPORT, R.I.—An automatic, self-contained, sonar navigation system was demonstrated last week on Narragansett Bay. Developed for Navy by Raytheon's Submarine Signal division, the system is reportedly the first full-scale application of doppler sonar and inertial principles to marine navigation.

Four-headed sonar transducers bounce signals off the bottom, fore and aft to port and starboard. Frequency shifts in the return signal provide direct measurement of the vessel's motion over the bottom. A solid-state digital computer processes the data and plots the course on a standard navigational chart. System's main role is to record a course between known points, or fixes.

Since the ocean bottom is used solely as a fixed frame of reference, no compensation is required for tides and wind. Depth or features of the bottom are subtracted from the returns. Raytheon officials said Navy would not allow accuracy to be dis-

closed, but in demonstrations on Narragansett Bay, the system has steered a boat to within feet of a pier.

Cost and Applications—Conceived five years ago, the system has been under development since by a group headed by Edwin E. Turner. Raytheon is building two prototypes under a \$400,000 Navy contract.

W. Rogers Hamel, division manager, says a fully militarized system can be produced in production lots for about \$30,000. It could be used for tactical maneuvers under cover of fog or darkness, precise positioning for fire control in ship-to-shore shelling, and safe navigation through

ITU Allocations: Final List

GENEVA—Approximately 15 percent of the radio spectrum was allocated to space communications at the International Telecommunications Union Conference which ended Nov. 8. The allocations are listed below. Allocations not identified as exclusive are shared with other services (there were some inaccuracies in the list published on p 7 of our Nov. 8 issue). A spectrum chart of frequency allocations for all regions was published in **ELECTRONICS**, April 13, 1962.

15,762-15,768 kc	space research				
18,030-18,036 kc	space research				
30.005-30.010 Mc	space research and satellite identification	143.6-143.65 Mc	(telemetering and tracking)	460-470 Mc	meteorological-satellites
37.75-38.25 Mc	radio astronomy	149.9-150.05 Mc	space research (telemetering and tracking)	1,400-1,427 Mc	radio astronomy exclusive
73-74.6 Mc	radio astronomy (exclusive)	267-273 Mc	radionavigation - satellite (exclusive)	1,427-1,429 Mc	space (telecommand)
136-137 Mc	space research (telemetering and tracking) (shared in Regions 1 and 3, exclusive in Region 2)	399.9-400.05 Mc	space (telemetering)	1,525-1,535 Mc	space (telemetering)
137-138 Mc	meteorological - satellite, space research (telemetering and tracking), space	400.05-401 Mc	radionavigation - satellites (exclusive)	1,535-1,540 Mc	space (telemetering) (exclusive)
		401-402 Mc	meteorological - satellites (maintenance telemetering), space research (telemetering and tracking)		
			space (telemetering)	1,660-1,670 Mc	meteorological-satellites
				1,664.4-1,668.4 Mc	radio astronomy
				1,690-1,700 Mc	meteorological-satellites
				1,700-1,710 Mc	space research (telemetering and tracking)
				1,770-1,790 Mc	meteorological-satellites
				2,290-2,300 Mc	space research (telemetering and tracking in deep space)
				2,690-2,700 Mc	radio astronomy (exclusive)
				3,400-4,200 Mc	communication - satellites (satellite-to-earth)
				4,400-4,700 Mc	communication - satellites (satellite-to-earth)
				4,990-5,000 Mc	radio astronomy
				5,250-5,255 Mc	space research
				5,670-5,725 Mc	space research (deep space)
				5,725-5,850 Mc	communication - satellites (earth-to-satellite) (only in Region 1 and shared)
				5,850-5,925 Mc	communication - satellites (earth-to-satellite) (only in Regions 1 and 3 and shared)
				5,925-6,425 Mc	communication - satellites (earth to satellite)

known mine fields, or by submarines.

Within three years, Raytheon hopes to sell a commercial model costing between \$5,000 and \$10,000. Besides foul-weather navigation, it could be used to locate choice fishing spots, buoy sites and damaged cables. With radar for collision avoidance, ferries could use it for pier-to-pier navigation in heavy fog.

System Operation—Emitting and detecting transducers mounted contiguously on a shaft operate simultaneously and in a continuous mode. Transmitter power level is described as "extremely low."

Returns are processed and integrated by the computer, whose output is incremental voltages which move the plotting pen. The track of the vessel's point-to-point progress is shown on a standard Coast and Geodetic Survey or Navy Hydrographic chart. Charts of different scales can be accommodated by a scale-selection switch.

Orientation of the vessel and the sonar transmitter is accomplished by a gyrocompass and undisclosed techniques. Turner said navigational accuracy depends on precision of the heading reference, but pointed out that Navy "has some very fine gyrocompasses."

There is some loss of precision at great depth, but this can be corrected by increasing transducer size and by lowering frequency.

7,250-7,300 Mc	communication - satellites (satellite - to - earth) (exclusive)
7,300-7,750 Mc	communication - satellites
7,900-7,975 Mc	communication - satellites (earth-to-satellite)
7,975-8,025 Mc	communication - satellites (earth - to - satellite) (exclusive)
8,025-8,400 Mc	communication - satellites (earth - to - satellite) (exclusive)
8,400-8,500 Mc	space research (shared in Regions 1 and 3, exclusive in Region 2)
10.68-10.7 Gc	radio astronomy (exclusive)
14.3-14.4 Gc	radionavigation - satellites (exclusive)
15.25-15.35 Gc	space research (exclusive)
15.35-15.4 Gc	radio astronomy (exclusive)
19.3-19.4 Gc	radio astronomy (exclusive)
31-31.3 Gc	space research
31.3-31.5 Gc	radio astronomy (exclusive)
31.5-31.8Gc	space research (shared in Regions 1 and 3, exclusive in Region 2)
31.8-32.3 Gc	space research
33-33.4 Gc	radio astronomy (only in Region 1 and shared)
34.2-35.2 Gc	space research

WHY MACHLETT OFFERS THREE COOLING/INSULATION OPTIONS IN RADAR SWITCH TUBES



ML-8038

ML-8040

ML-8041

Oil cooled ML-8038. Anode dissipation: oil (convection) to 5 kW*; Max. dc Plate Volts, 125 kV; Pulse Cathode Current, 175 amp.; Pulse Power Output, to 20 Mw.

Forced air cooled ML-8040. Anode dissipation: forced air cooled to 10 kW; Max. dc Plate Volts, 60 kV; Pulse Cathode Current, 175 amp.; Pulse Power Output, to 10 Mw.

Water cooled ML-8041.** Anode dissipation: water cooled to 60 kW; Max. dc Plate Volts, 60 kV; Pulse Cathode Current, 175 amp.; Pulse Power Output, to 10 Mw.

TO HELP YOU OPTIMIZE DESIGN, Machlett offers three coaxial switch tubes (to 125 kV... 20 Mw... 1000 μ sec Pulse) in three cooling/insulation options. All tubes are of the same family: (μ : 120, low inductance, terminal structure; thoriated-tungsten-cathode). All incorporate internal shielding to assure high voltage stability and achieve low x-radiation yield. All tubes are aged and operated above peak ratings in Machlett test equipment.

Applications: Radar systems, linear accelerators, klystron and/or amplatron test equipment. For complete technical data get our 74-page Hard Pulse Modulator Tube Brochure. Write: The Machlett Laboratories, Inc., Springdale, Conn. An affiliate of Raytheon Company.

*Forced oil cooling considerably increases this figure.

**May be operated oil insulated (and not water cooled) to 125 kV.



MITSUBISHI MICROWAVE ANTENNAS FOR TELECOMMUNICATIONS

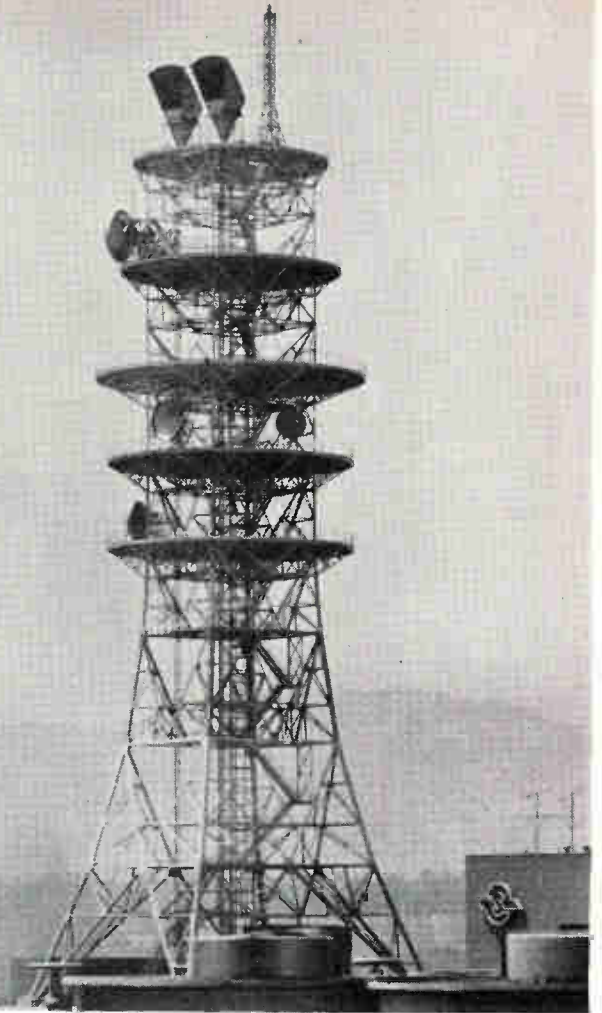

Japan today has the second largest microwave network in the world. Mitsubishi Electric, with the longest microwave antenna experience in Japan, has supplied 90% of the antennas used in the trunk lines of this extensive network. Mitsubishi antenna systems include parabolic, scatter, horn reflector and radar types, as well as a complete line of waveguide components and accessories. Frequencies from 900 Mc. to 24 KMc. are covered. The IU-62, shown above and specified at the right, is typical of the outstanding performance of Mitsubishi microwave antennas. Full technical information on any of these types of antennas is available at your request.

IU-62 Horn Reflector Antenna

Frequency Range : 3,000-12,000 MC
 Aperture : 9m²
 Max. width : 4,050mm
 Max. depth : 2,560mm
 Max. height : 7,418mm
 Gain at 3,900MC : V 41.5 db
 H 41.2 db
 Gain at 6,100MC : V 44.9 db
 H 45.0 db
 VSWR : 1.01
 Front/Back : 67-70 db
 (over 60 degrees)
 Discrimination of : V 57 db
 cross polarization : H 78 db (at 3,900MC)
 V 45 db
 H 37.5 db (at 6,100MC)
 Guaranteed wind velocity : 140 miles/hr



MITSUBISHI ELECTRIC CORPORATION

Head Office: Mitsubishi Denki Bldg., Marunouchi, Tokyo. Cable Address: MELCO TOKYO

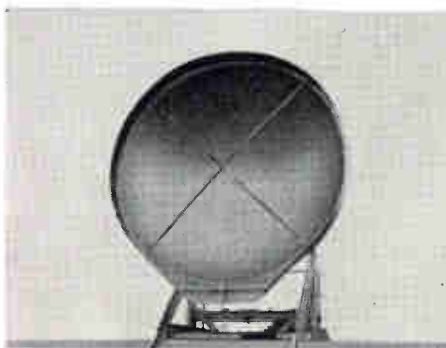

■ 20 meter diameter antenna for satellite communication



■ Air inflated parabolic antenna

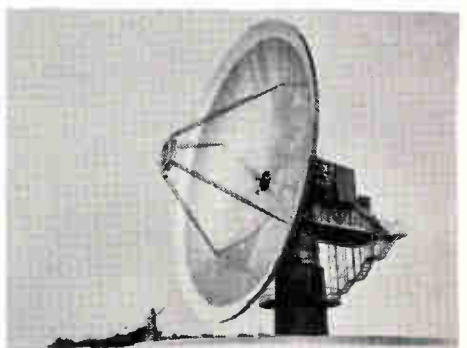

■ IU-61 parabola antenna

Coming—Checkout After Blastoff

COLUMBUS, OHIO—Launch vehicle checkout systems may soon reach beyond blastoff. This was the point made by several speakers last week at the Seminar on Automatic Checkout Equipment and Techniques at Battelle Memorial Institute.

Carl Steeg Jr., of ITT Industrial Labs, said an Inflight Management System (IMS) would increase vehicle efficiency to such an extent that two out of three of the spare vehicles now thought necessary to carry out the Saturn program could be eliminated. IMS would detect failed components and subsystems and switch to the substitute equipment or other operational modes. If this could not be done, it would select alternate missions or control paths within the capabilities of those subsystems that were functioning properly.

Stuart Vogt, NASA Office of Advanced Research and Technology, said post-launch checkout should reduce computer sizes, weights and power consumption. Frank Medved, Honeywell Aero Division, said time sharing of existing digital computers would be an economical way to speed up airborne checkout. Added capabilities need only include enough memory to accommodate test programs and separate data input and output channels.

UN Is Drafting Satellite Controls

UNITED NATIONS, N. Y.—American and Soviet negotiators have reached an agreement that would put all space satellites, including Telstar, under government control. While this would not preclude U.S. industry's participation in space communications, it would place ultimate responsibility on government rather than industry.

The draft resolution, expected to come up shortly, will also provide a means for countries to protest another nation's space experiments. For example, Europeans could ob-

DOD Wants to Know Where Its Money Goes

WASHINGTON—A survey of how much defense business various companies perform will be taken as part of the annual Census Bureau survey of manufacturing in the next few months. The aim is to get a better picture of where the defense dollar is going and where it ends up after it is all subcontracted out. The survey is part of a DOD effort to set up an "early warning system" for business to help companies and communities plan ahead for shifts in defense procurement (p 20, Nov. 8). The Institute for Defense analysis is making a more exhaustive year-long study of the same problem.

ject if the U. S. moves to release another orbiting dipole belt (p 26, Nov. 8). The State Dept. said no treaty to back up the UN resolution is contemplated.

EIA Asks Extension Of Uhf-Tv Radiation Limit

ROCHESTER—EIA engineering representatives at the Radio Fall Meeting last week agreed that the temporary FCC limitation on radiation from uhf-tv receivers must be maintained for another year. The present 1,000-microvolt per meter allowance is scheduled for return to 500 microvolts at the end of April, when the all-channel tv law making uhf-vhf coverage mandatory becomes effective. Industry tests of 253 receivers with tube tuners in 1962 showed only 141 sets with radiation less than 500 microvolts. Similar tests this year showed only 110 out of 242 acceptable, but industry engineers are confident that transistor tuners now in development will meet requirements.

Linear-Beam Klystron Generates 5-Mw Peak

SAN CARLOS, CALIF.—Litton Industries announced full-power opera-

tion of its 5-Mw peak, 300-kw average power klystron operating over the frequency range of 1,256 to 1,386 Mc. Developed for a radar system for RCA, the tube reportedly generates the highest power possible at the present time from a linear-beam device. Called the L-3401, the tube uses a nonintercepting modulating anode to permit sophisticated modulation techniques. It is tunable over its operating range with an r-f duty cycle of 0.063 and a pulse length of 40 to 500 microseconds. Unique design features include a collector capable of dissipating 1.3 Mw and an output window designed to handle power up to 380 kw average.

Apollo Data Adapter Will Standardize Parts

HUNTSVILLE, ALA.—Data adapter built into Saturn V's guidance control system will make the moon rocket's computer and other key elements transferrable to space vehicles with different missions—even interplanetary flights, says a Marshall Space Flight Center spokesman. Some post-Apollo flights will need more guidance gear, NASA said, and the adapter was designed with this in mind: it will hold items most likely to be changed. Along

with other Saturn IB and V components, it's being developed under a \$75-million contract to IBM. When finished, it will go among guidance, control, and telemetry gear in the rocket's instrumentation unit (p 10, Nov. 15).

Communications Processor Gets First Public Showing

FIRST PUBLIC showing of Philco's PCP-150 communications processing system took place last week at the Fall Joint Computer Conference in Las Vegas, Nev. The message and data-switching system can handle hundreds of remote terminals. The processor is compatible with all standard telegraph and data-transmission rates, from 45 to 40,800 bits per second, and keeps a running inventory of all messages. It buffers backlog traffic, performs traffic analyses, and generates accounting and billing data.

Memory cycle time is 2.5 microseconds per instruction. The magnetic core storage may be augmented by magnetic drum, disk or tape systems. Communication ter-

minal units are adaptable to wire-line, microwave, troposcatter and h-f radio transmission. The system can process facsimile and photographic transmission in digital form.

Vapor Process Improves Quality of Crystals

ANAHEIM, CALIF. — Autonetics is growing magnesium-oxide crystals through a chemical vapor process which lowers temperatures from 3,000 deg to 1,000 deg C and improves crystal quality by eliminating thermal strains. This process also removes the inability to gain uniform high-heat generation, a previous barrier to large crystal growth.

Cerium-dioxide crystals are also being grown. Rare earth ions will be introduced into cerium dioxide and their laser performance characteristics studied. Because these ions have good lasing characteristics, scientists believe this combination will result in added laser-action efficiency. The two programs are being carried out under a \$144,000 contract from the Office of Naval Research.

Army's Everyman Radios —Decision a Year Off

ARMY WON'T decide for at least a year whether to buy small radio receivers and transmitters for front-line troops (p 10, Nov. 1). Field tests won't be completed until next fall. To equip front-line squads in the 16 present combat divisions would require 4,320 transmitters and 51,840 receivers. Army sources consider this large a buy unlikely, but say that if the sets prove out priority-type units may be equipped. To date, Army has bought 100 of the sets from Delco Radio

NEMA Draws Up Guidelines For Silicon Rectifiers

NEMA SAYS it has made "the first breakthrough" in efforts to standardize the marking, manufacture, and marketing of silicon rectifier diodes. Questions such as definition, letter symbols, ratings and performance will be answered in a new NEMA publication, say spokesmen. It will be discussed Dec. 3 at a press conference held in New York by the Association's Power Semiconductor Component Section.

Lasers Promise Printers Sharper, Quicker Engravings

COLUMBUS, OHIO—Lasers promise quicker production, tighter control and simpler processing of engravings for printing, says William T. Reid, of Battelle Memorial Institute. Depth and volume of engravings may be varied by modulating laser-beam energy with a computer or output of a photocell scanning a positive, he said. A 1-Mc modulation frequency could engrave a 10-square-inch plate in four seconds. But first, more powerful lasers are needed, Reid says. Printers might also use a modulated beam scanning photosensitive paper to build an image point by point.

MEETINGS AHEAD

NUCLEAR ELECTRONICS INTERNATIONAL SYMPOSIUM, SFDERE; Unesco Headquarters, Paris, France, Nov. 25-27.

DEFENSE ELECTRONICS SEMINAR, Defense Supply Association; Fort Jay, Staten Island, New York, Dec. 3.

WIRE AND CABLE SYMPOSIUM, Army Electronics Labs; Berkeley-Carteret Hotel, Asbury Park, N. J., Dec. 4-6.

ULTRASONICS ENGINEERING SYMPOSIUM, IEEE-PTGUE; Marriott Motor Hotel, Washington, D. C., Dec. 4-6.

VEHICULAR COMMUNICATIONS NATIONAL CONFERENCE, IEEE-PTGVC; Adolphus Hotel, Dallas, Texas, Dec. 5-6.

RELIABILITY IN SPACE VEHICLES SEMINAR, IEEE-PTGR, ED, CP; Los Angeles, Calif., Dec. 6.

FALL URSI MEETING, IEEE Seattle Section, URSI, Boeing Scientific Research Laboratories; University of Washington, Seattle, Wash., Dec. 9-12.

NON-LINEAR PROCESSES IN THE IONOSPHERE MEETING, NBS; Central Radio Propagation Laboratory, Boulder, Colo., Dec. 16-17.

AMERICAN ASSOCIATION FOR THE ADVANCEMENT OF SCIENCE MEETING, AAAS; Cleveland, Ohio, Dec. 26-30.

RELIABILITY-QUALITY CONTROL NATIONAL SYMPOSIUM, IEEE, ASQC, ASME, EIA; Statler Hilton Hotel, Washington, D. C., Jan. 7-9.

INTEGRATED CIRCUITS SEMINAR, IEEE New York Chapter; Stevens Institute of Technology, Hoboken, New Jersey, Jan. 15.

INSTRUMENTATION SYMPOSIUM, ISA North Central Area; New Sheraton-Ritz Hotel, Minneapolis, Minnesota, Jan. 30-31.

ADVANCE REPORT

NATIONAL TELEMETERING CONFERENCE, AIAA; Biltmore Hotel, Los Angeles, Calif., June 2-4, 1964; Jan. 1, 1964, is deadline for submitting four copies of papers to Warren S. Pope, Technical Program Chairman, National Telemetering Conference, 8420 Quinn St., Downey, Calif. Some topics include transducers, signal conditioners, multiplexing and coding, modulation methods, sync and error detection, data transmission and reception, data processing.

Huge Job-Saving Plan Urged

HUGHES EXECUTIVE this week urged the federal government to embark on a massive program to fill the known needs of the military and the general public for advanced technical systems. The plan would save existing jobs and create new ones for at least two million Americans, says Lawrence A. Hyland, Hughes Aircraft vice president and general manager. He estimated the plan's cost at \$10 billion.

Hyland listed more than a score of specific projects that are now "within the capabilities of the defense electronics industry." They lie, he said, in such areas as antisubmarine warfare, antiballistic missiles, world-wide inspection and surveillance, communications, education aids, internal security, air traffic control, world mapping, water resources control, medical electronics, cryogenics, microelectronics and solar energy. He presented his plan to the Senate Subcommittee on Employment and Man-Power.

Automatic Broadcaster Has 896-Word Vocabulary

COLUMBUS, OHIO — An automatic weather broadcaster, under FAA study for a year and a half, was introduced at the Automatic Checkout Equipment and Techniques Seminar this month at Battelle Memorial Institute. Called Ordered Random Access Talking Equipment, it provides random access digital-to-voice readout, according to Bell Aerosystems, and shows progress toward the perfection of talk-along checkout machines.

Four film strips, each carrying 32 variable-width sound tracks with an 896-word total vocabulary, are wrapped around separate transparent transport cylinders. Reading heads and associated optical light collection systems permit 50-millisecond access to words and phrases in seven progressively larger 0.6-second increments. Readout is by electromechanical switching of light to a reading slit over the appropriate track.

Digital Computer Has Real-Time Use

LOS ANGELES — Beckman Instruments says it has developed a digital computer specifically for real-time acquisition and data processing in systems applications. The Model

420 computer has two independent data processors, one controlling routing and handling of input-output data and the other performing normal mathematical functions. It will accept real-time data at speeds up to 312,000 words per second and process and record results on magnetic tape.

The system includes a magnetic-core memory; input and output data transfer synchronization circuitry for up to 8 independent full buffered channels, and a central processor with 56 basic commands and control circuitry for stored program flexibility. Units are priced from \$120,000 to \$300,000. Boeing and the Atlantic Missile Range have each ordered one.

NASA Electronics Center —Michigan Makes Its Bid

MICHIGAN WANTS that \$50-million space electronics center originally proposed for the Boston area (p. 17, Oct. 25). Harlan Hatcher, president of the University of Michigan, has written NASA asking that the facility be located in southeastern Michigan. Says Hatcher: "We believe this opportunity to be a natural complement to the civilian technology presently being fostered in our locale among NASA-supported facilities, academic institutions, and the industrial community."

IN BRIEF

MOTOROLA has received a \$300,000 contract to produce microelectronic integrated circuits for North American Aviation's Monica C computer. North American says that in the next 10 years several thousand microelectronic computers may be sold.

COMPUTER control system to smooth traffic in one of the three tubes of the New Jersey-New York Lincoln Tunnel, got the green light last week after two years of try-outs (p. 18, Nov. 16, 1962). The Port of New York Authority said it has authorized \$322,000 for the system.

POST OFFICE has awarded three contracts worth a total of \$1,250,000 for an optical scanner capable of reading 17,000 Zip-coded addresses per hour. The firms are National Cash Register, Rabinow Corp. and Burroughs.

LEAR SIEGLER Inc. has received four contracts worth \$7.8-million from Subscription Television Inc. Largest, \$4.8-million, is for production of program selectors.

NATIONAL Aeronautical Corp. has bought Electro-Nuclear Apparatus Co., makers of Ioran navigation equipment, for stock and cash.

REAL-TIME computer, designed for the military by Honeywell, has an 8,192-word memory and 6 microsecond cycle. It was designed for rugged field use.

LUNAR TRANSPONDER developed by General Dynamics for the Air Force can be used to help measure earth-moon distance, or as a navigational beacon. It weighs 4.3 pounds and can withstand 3,000 g shock in any direction for 3 milliseconds.

AEC will negotiate contracts with GE and Martin Marietta for nuclear power generators for the SNAP program.

EUROPE has received its first order of Japanese high-output tv equipment—Toshiba's 25 kw tv broadcaster exported to Spain.

NAVY HAS GIVEN Thompson Ramo Wooldridge a \$40,000 contract for research on the application of on-line computation techniques to command and control situations.

EDMUND B. FITZGERALD will succeed Philip Ryan, who retires Dec. 31 as president and chief executive officer of Cutler-Hammer Inc.

DSA Plans To Automate Parts Buying

In January, the Defense Supply Agency will inaugurate a pilot system to automate purchase and distribution of electronic parts, in orders under \$2,500. Items to be covered, like resistors, capacitors and tubes, make up 75 percent of all items handled by DSA. If the system at Defense Electronics Supply Center, in Dayton, succeeds, DSA's nine major supply centers will get one within the following year.

Requisitions from military services will be fed into the Dayton machine. If its memory shows insufficient stocks are on hand, the system will issue a procurement directive and the names of competent manufacturers. Bids will be requested from industry, evaluated by procurement personnel and fed into the system, which will produce procurement orders. The equipment will monitor purchase orders and payments, and instruct DSA depots to fill the original requisitions.

New Study of Highway Needs Gets Underway

Bureau of Public Roads is starting a study of what transportation needs will be 30 to 40 years from now. It will seek ways to improve the traditional auto-highway system, explore electronic automation for no-hands driving and highways filled to bumper-to-bumper capacity, and appraise alternatives such as ground-effect vehicles, pneumatic tubes, conveyor belts and air vehicles guided by laser beams.

This week, officials plan to issue specifications and seek bids for a systems analysis that will lay the foundation for an R&D program. The analysis is expected to cost \$2 million and take two years.

There are already some specific proposals, including driverless autos and improved traffic-control communications. Some manufacturers contend prototype testing is justified. But Bureau officials want a systems analysis first because they question the wisdom of superimposing new devices on the existing system and want to raise some basic questions: Can the control problem best be solved by redesigning the vehicle or the highway? Should a large, central computer control groups of vehicles by telemetry, or should each have a small computer?

Congress Pares Budget for Airway Systems

Sharp cut in funds sought by the Federal Aviation Agency to modernize airway operations has been recommended by the Senate Appropriations Committee. FAA asked for \$127 million for air navigation aids, radar and other equipment. The House of Representatives cut this to \$110 million. Now the Senate Committee recommends a further cut of \$10 million, to \$100 million.

However, the Senate committee has recommended more than the House approved for FAA R&D programs. FAA sought \$50 million for R&D; the House voted \$35 million and the senators are recommending \$45 million. The Senate committee went along with the House on a \$60-million first installment of an expected \$750-million government outlay for developing the supersonic transport plane (SST).

NASA May Have to Cut Nuclear Program

Senate Appropriations Committee has restored nearly half the money that the House of Representatives has pared from space spending. The Senate committee restored \$90 million of the \$190 million cut by the House, but the Senate total, \$5.19 billion is still \$160 million less than Congress had authorized. NASA originally requested \$5.7 billion.

When NASA divides the funds that Congress finally approves, the agency may have to decrease the Rover nuclear rocket project (ELECTRONICS, p 24, Dec. 28, 1962) and nuclear-electric programs. In the authorization bill, Rover got about \$110 million for development and construction work.

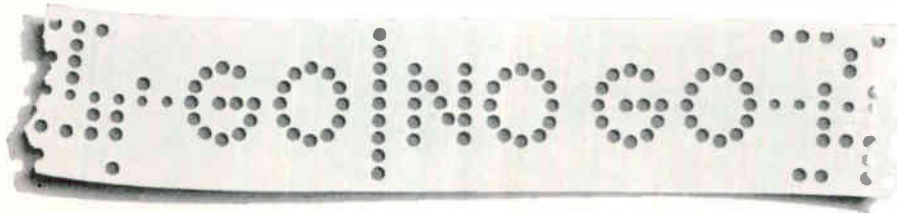

DATA PROCESSING SYSTEMS FOR SPACE

Advanced STL digital telemetry units, decoders, and command distribution assemblies are now being used on NASA's OGO and Pioneer, and the Air Force's Nuclear Test Detection spacecraft. STL hardware and experience with on-board data processing equipment is being applied in the development of new systems which will perform checkout and maintenance functions in space. This advanced technology requires circuit designers, logic designers, and digital systems engineers. For Southern California or Cape Canaveral opportunities, write Professional Placement, One Space Park, Dept.G-11, Redondo Beach, California, or P.O. Box 4277, Patrick AFB, Florida. STL is an equal opportunity employer.

TRW SPACE TECHNOLOGY LABORATORIES
THOMPSON RAMO WOOLORIDGE INC.

**Western Electric
carbon resistors
now protected
by Kynar®**



Latest refinement in carbon film resistors made by Western Electric is a sleeve of Kynar,* Pennsalt vinylidene fluoride resin. Western Electric produces 30 million resistors of this type yearly for ANI (Automatic Number Identification) equipment.

Western Electric engineers selected Kynar for two principal reasons—strength and stability. Kynar won't melt, drip or burn, under the most severe overloads. Its superior stability assures freedom from degradation due to aging

or environmental conditions. Kynar is completely compatible with high-speed production. Extruded tubing feeds readily through forming equipment, cuts cleanly, heat-forms easily, takes marking inks.

Kynar offers a unique combination of electrical strength, mechanical toughness and stability. If you have a problem where you need extra performance, write or call us for data. Plastics Dept., PENNSALT CHEMICALS CORPORATION, 3 Penn Center, Philadelphia 2, Pa.

Kynar...a fluoroplastic that's tough!

*Kynar is a Registered Trademark of Pennsalt Chemicals Corp.



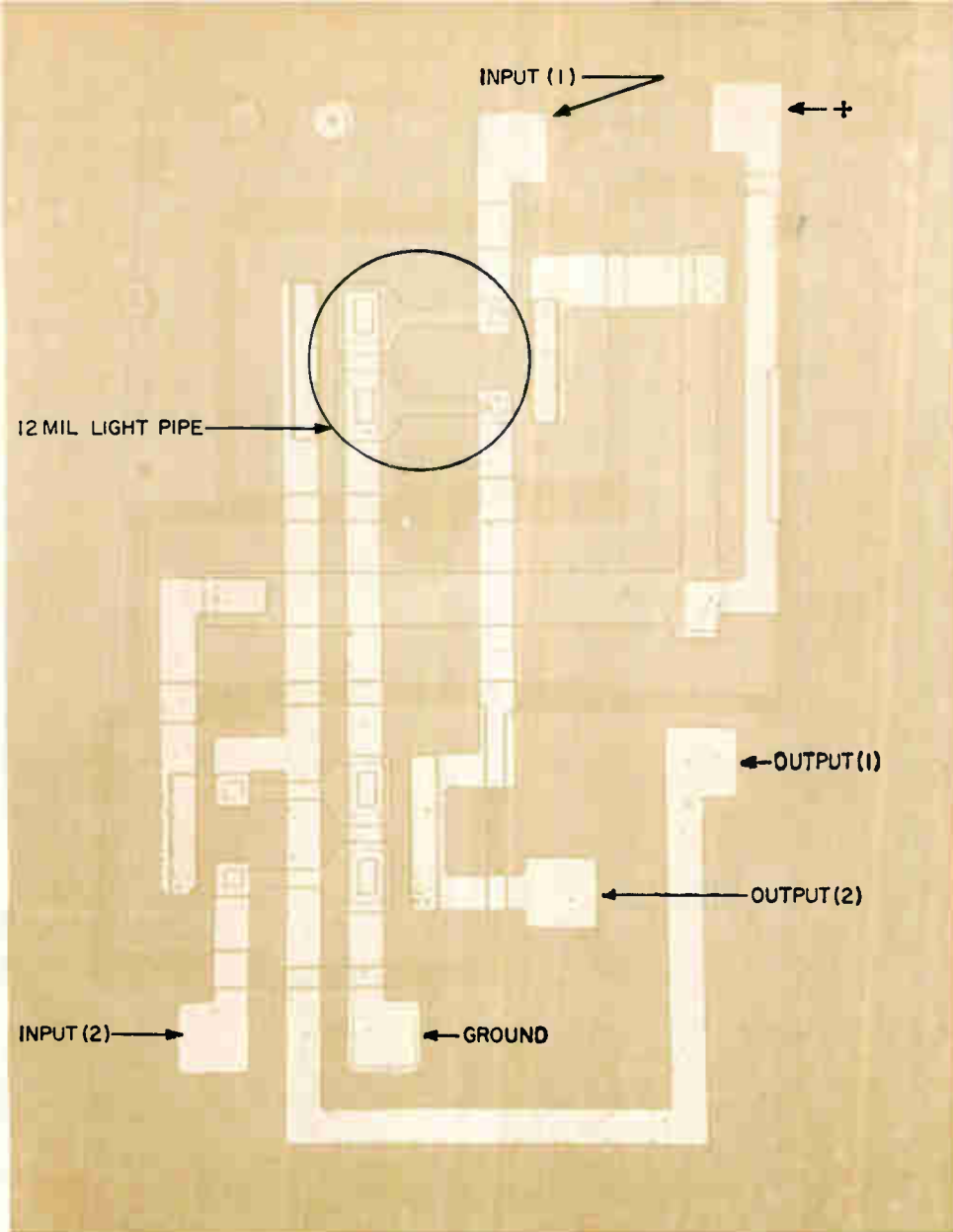

PHOTOMICROGRAPH at 135 times magnification shows microcircuit flip-flop driven through 12-mil light pipe (circled)

OPTICAL COUPLING: NEW APPROACH TO MICROCIRCUIT INTERCONNECTIONS

Experimental techniques lead to success
with arsenic trisulfide light pipes

By **M. A. GILLES** and **J. T. LAST**
Amelco Semiconductor, Mountain View, California

INDIVIDUAL MICROCIRCUITS in large number can be wholly formed on a silicon wafer an inch in diameter and a few mils thick. A group of such microcircuits can be mounted on a substrate for interconnection into a much larger array, or connected using thin, photoengraved metal film on the wafer sur-

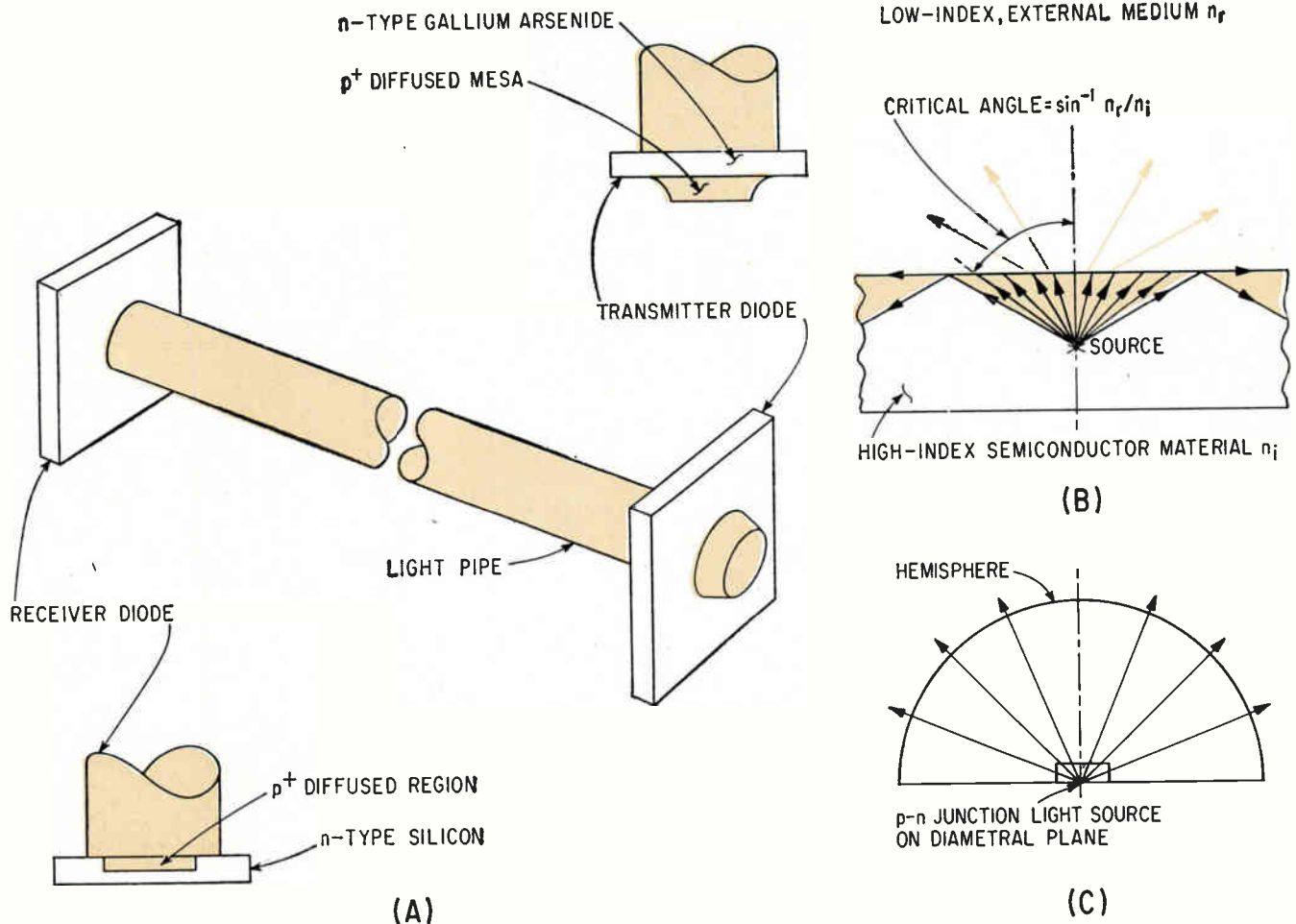

OPTICAL coupling of microcircuit pair with light pipe (A) escape of light through plane surface from light source within semiconductor having high refractive index (B) and light source in Weierstrass sphere (C)—Fig. 1

face. To interconnect a stacked array of these plates, the wiring must cross the surface of one layer, make connection with external wiring, translate to another layer and cross its surface to the desired point. Direct connection between the layers would greatly decrease the problem of combining stacked plates of microcircuits. Optical means of interconnection between layers can add a new dimension both to the directions available for wiring and to system performance.

More Reliability—A signal carried by light can be transferred between layers without electrical contact or regard to any differences of electric potential. Consequently, in high-speed circuits, coaxial cables or strip lines of small dimensions are not needed and the labor involved is eliminated. In addition, reducing the number of external connections,

which have a lower reliability than the photoengraved wiring, improves overall system reliability.

Optical coupling between integrated circuits is possible because *p-n* junctions can efficiently convert current to radiation by charge-carrier recombination and reconvert radiation to current by the photovoltaic effect. In elementary form, an optically coupled circuit com-

prises two *p-n* junctions, one transmitting radiation and the other receiving radiation by means of a light pipe as shown in Fig. 1A. Although much refinement of detail remains, this method of circuit interconnection can now be used to change the state of a standard, microcircuit flip-flop optically.

Conversion of radiation to light in silicon has been brought to a high

GIANT STEP?

Reliability, simplicity and economy can all be expected from better methods of interconnecting microcircuit groups. The method described in this article has been only a topic of conversation until recently. Now that optical interconnection has been accomplished it has nowhere to go but in the direction of further improvement and refinement. Understanding the problem and utilizing recent discoveries has produced a successful experiment. It looks more like a quantum jump than an incremental advance

state of development through extensive work on solar cells. A yield of more than 0.5 charge-carrier pair per incident photon can be obtained from a solar cell at wavelengths between 0.45 and 0.9 microns to which its response is the greatest.¹ The photovoltaic effect in the collector-base junction of a transistor results in a phototransistor that may have a gain of 100 or more.

Radiation Production—When a forward current flows through a silicon *p-n* junction, radiation is produced with an efficiency as high as 5×10^{-4} photons per electron at a wavelength of about 1.1 microns.^{2,3} The speed of response corresponds to the minority-carrier lifetime, which may be as long as one microsecond to give the efficiency stated.^{3,4} In reverse-current operation the speed corresponds to the majority-carrier lifetime, which is three or four orders of magnitude shorter than the minority-carrier lifetime.² The efficiency for the production of radiation at wavelength less than about 1.1 microns is one to two orders of magnitude smaller for reverse than for forward-current operation.^{2,3} The reverse-current radiation spectrum extends from 0.35 to perhaps 3 microns.^{3,5} The photoresponse of a silicon diode is down almost an order of magnitude at 1.1 microns from its peak value and vanishes at wavelengths much beyond 1.2 microns.¹ Therefore, although silicon junctions can provide a current-transfer pair, it is not efficient.

Fortunately, the efficiency of radiative recombination in gallium arsenide, and in other III-V compound *p-n* junctions, was recently discovered to be as high as 0.1 photon per electron at room temperature.⁶ Moreover, the radiation wavelength of about 0.9 micron for gallium arsenide at room temperature occurs in the region of high response for silicon diodes. A current transfer as high as 10^{-2} is therefore possible between a gallium-arsenide light source and silicon diode. The transfer could exceed unity if the receiver were a phototransistor. At or below the temperature of liquid nitrogen (77 K) unit current transfer could be approached with a diode receiver because the source efficiency approaches unity.^{6,7} In addition, the charge-carrier lifetime in gallium arsenide is less than 10^{-8}

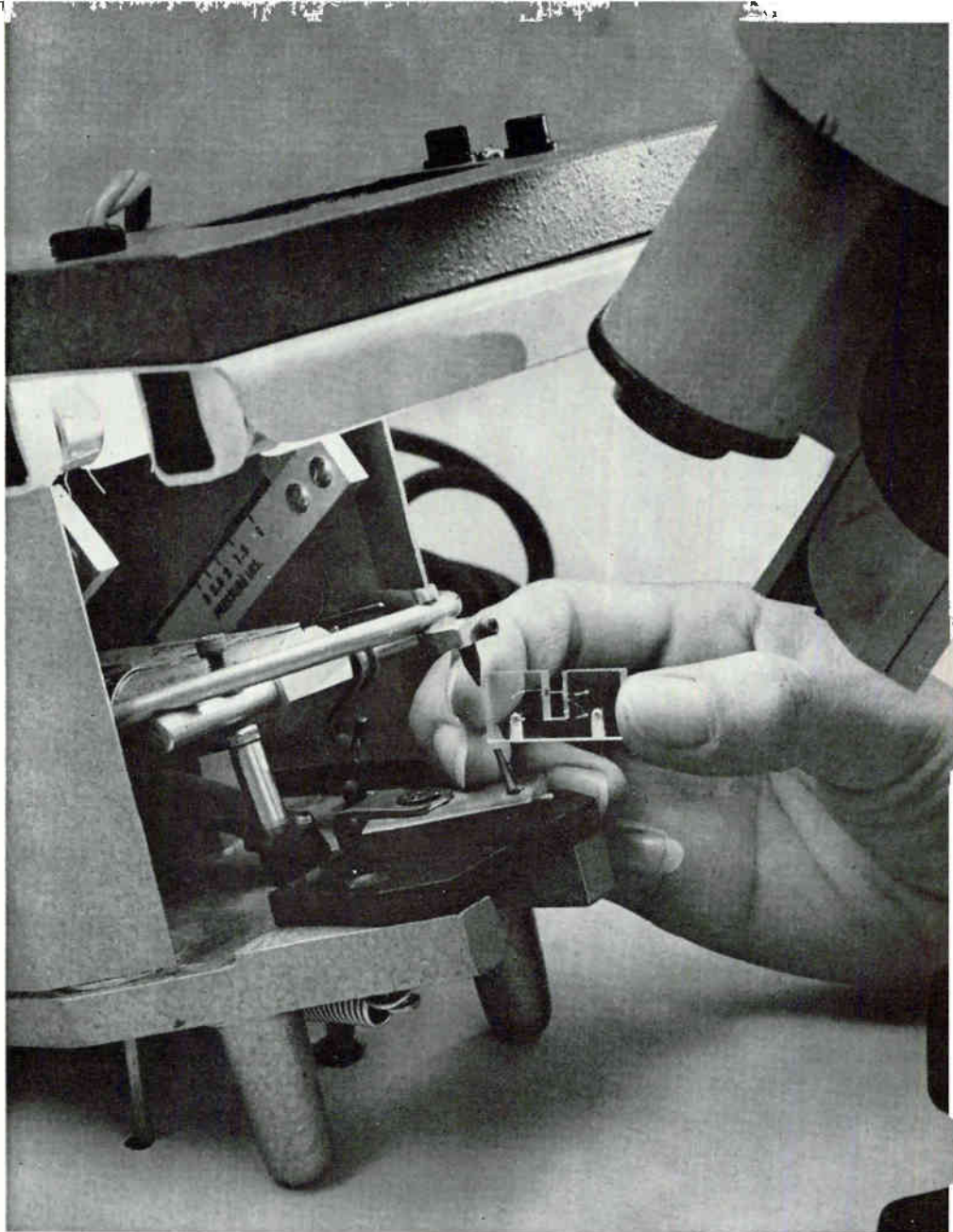

WELDING gold leads from a pair of diodes coupled by a light pipe

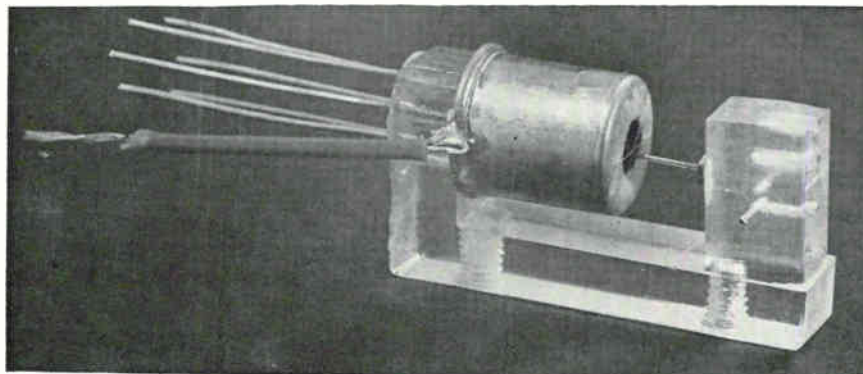

SHIELD CAN holds microcircuit. Arsenic trisulfide light pipe carries driving impulse from gallium arsenide light source (right)

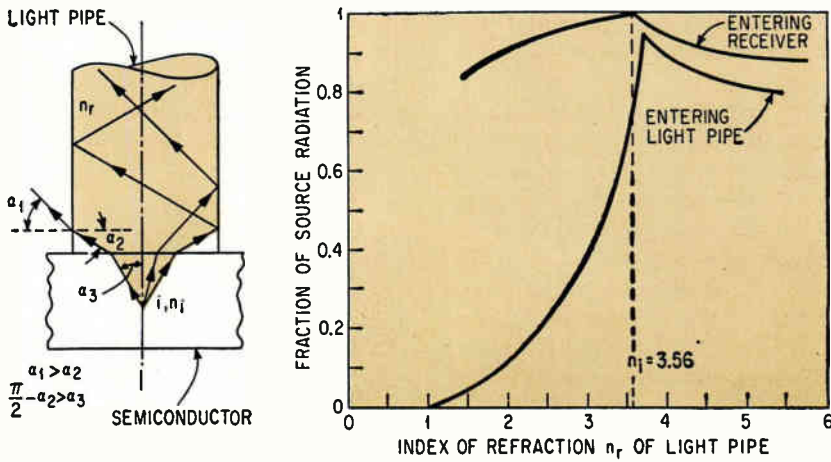

LIGHT PATHS from semiconductor source into light pipe (left) and curves showing fraction of light entering pipe from source and that reentering a receiving medium of same refractive index, as function of light-pipe refractive index—Fig. 2

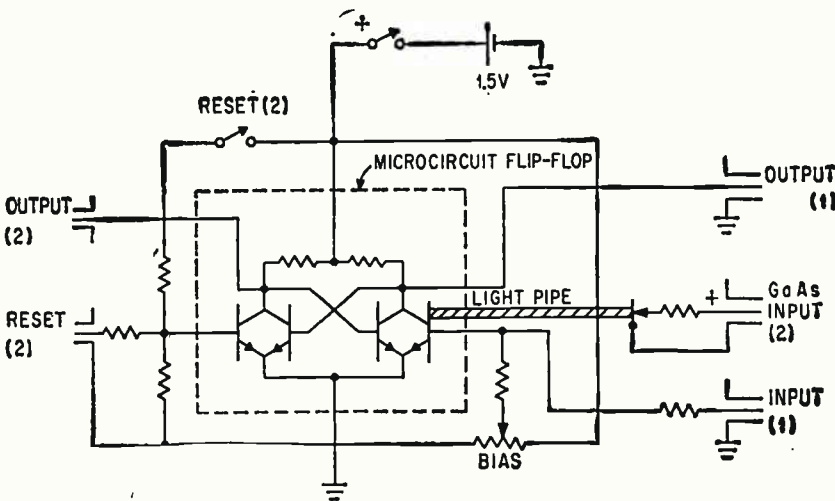

MICROCIRCUIT flip-flop optically actuated by light pipe to GaAs diode in another circuit—Fig. 3

sec and may be shorter than 10^{-9} sec—even with relatively efficient light production—so response is fast.⁶

Optical Coupling—Difficulties in efficient optical coupling of integrated circuits are imposed by optical properties of semiconductor materials. Methods of achieving a high transfer coefficient are found by a detailed study of optical reflection and refraction problems.

Close optical coupling of the light source and the receiver is not readily achieved between separate units because the indices of refraction of gallium arsenide⁸ and silicon⁹ are large—about 3.6 at the emitted wavelengths. As a consequence of the high refractive index of the semi-

conductor material in which the radiation is produced, much of the radiation is trapped by internal reflection. Less than three percent of the radiation incident on a plane surface escapes into air. Only the radiation within a cone of about a 16-deg half-angle with an axis normal to the surface is available as shown in Fig. 1B. Because of refraction at the surface, the exit radiation that originates within the 16-deg cone is spread over a hemisphere in air.

Reflection loss for normal incidence at an interface between media with $n_i = 3.6$ and $n_r = 1$, given by $[(n_i - n_r)/(n_i + n_r)]^2 = 0.32$, is relatively small compared to internal reflection loss. Aigrain¹⁰ has shown that with a Weierstrass

sphere (Fig. 1C) in which all radiation is incident normal to the surface the escape efficiency becomes high. Despite its efficiency, fabrication and assembly of such spherical sources is incompatible with the microcircuit approach to optoelectronics.

Appreciable light coupling can be achieved by immersing both source and receiver in a medium with a high index of refraction, ideally about the same as that of source and receiver. The receiver must subtend as large a solid angle as possible at the source; however, a large subtended angle means appreciable capacitive coupling, which is to be avoided.

Light Pipes — Radiation can be transferred from one point to another using the highly efficient, multiple internal reflection in a light pipe. Internal reflection coefficient is essentially 100 percent whereas each metallic reflection involves a few percent loss except at large angles of incidence. For good light transfer, a light pipe should have a high index of refraction to minimize interface-reflection losses at the source. In addition, a high refractive index also increases the angle of the acceptance cone for radiation because the critical angle for internal reflection is given by $\theta = \sin^{-1} n_m/n_r$, where n_r is the index of the light pipe and n_m is the index of the surrounding medium.

To compare the merits of various materials for light pipes, the light entry into a pipe has been calculated^{8, 11} as a function of its refractive index (Fig. 2). In addition, the re-entry of light from the pipe into the receiving medium must also be considered in determining overall transfer. In these calculations, the Fresnel coefficients for transmission through a surface for both polarizations of light must be considered. It has been assumed here that the light source is unpolarized. For good performance, the index of refraction of the light pipe must closely approach that of the semiconductor material.

Glass Fibers—Materials suitable for practical application are inorganic glasses such as germanate glass with $n = 1.84$ at a 1 micron wavelength and arsenic trisulfide with $n = 2.47$ at 1 micron. A glassy material can be drawn into small-diameter rods

or fibers with the highly polished surface essential to good internal reflection at angles approaching the critical. At present, arsenic trisulfide appears to be the best material available. It has the higher index of refraction and yields light pipes of good quality. Even better inorganic glasses can probably be developed.

When integrated circuit arrays of sources and receivers are to be optically coupled, many light pipes are required. It is impractical to use individual light pipes but two alternatives are possible. The light pipes can be assembled in a matrix with a lower refractive index. Or, many small-diameter fibers coated with a lower-index material can be formed into a fiber-optic plate. The individual light pipe with a unit packing fraction gives somewhat better transfer than a fiber-optic plate. However, the source and receiver arrays must be carefully registered with the light pipes. The fiber-optic plate has a poorer transfer efficiency with a probable packing fraction of about one-half to three-quarters, but no registration is required in assembly.

Assemblies are now being made with gallium-arsenide light sources, silicon receivers and arsenic-trisulfide light pipes. The principal problem is to obtain an optically satisfactory, mechanical bond between the light pipe and the semiconductor devices. An inorganic glass consisting of arsenic, sulfur and iodine in about equal weight proportions¹² adheres well to gallium arsenide but not so well to silicon or to arsenic trisulfide. A high index of refraction, high-viscosity liquid containing arsenic tribromide, arsenic disulfide, antimony bromide, and selenium obtained better wetting. By heating, the volatile components may be diffused into (or reacted with) an

arsenic-trisulfide light pipe and partially vaporized to stiffen the joint.

Optical Actuation—To demonstrate directly the applicability of optical actuation to a device, an Amelco MC-303 microcircuit flip-flop was used. This unit employs four transistors of a new design (OMIC) that decreases the parasitic capacitance and the collector-emitter saturation voltage [$V_{CE}(\text{SAT})$] in integrated microcircuits. Performance compares favorably to that achieved with epitaxial techniques.

Optical actuation of the flip-flop shown in Fig. 3 works despite inefficient light transfer arising from poor matching of refractive indices and present lack of a microcircuit designed expressly for optical coupling. A 12-mil diameter light pipe of arsenic trisulfide was cemented over the two transistors on one side of the microcircuit illustrated. On the other end of the half-inch light pipe a gallium-arsenide diode was attached with epoxy cement to serve as the light source. A can with a hole for the light pipe shown in the photograph was placed on the TO-5 header that bears the microcircuit. Grounding the can gave sufficient shielding to avoid electrostatic coupling. The poor light transfer resulting from use of epoxy cement was much below that achievable using improved techniques.

The speed of operation of optically coupled elements is very high as far as light-source and receiver diodes are concerned. The minority-carrier lifetime in gallium-arsenide diodes is usually in the subnano- or nanosecond region, though the most efficient units may have radiative-recombination lifetimes of tens of nanoseconds. Receiver diodes of the *p-i-n* type may have response times in the subnanosecond region.¹³

Achieving sufficient amplification to attain unit current transfer with presently available phototransistors could increase overall response time of the system to between 10 and 100 nanoseconds.

Light Sources — In some applications a light source operating in a laser mode could provide more efficient radiation. With radiation more nearly collimated, interface reflection losses could be reduced and transmission losses would be low owing to slight internal reflection required in the light pipe. The line-source form of most diffused solid-state lasers make a laminar light pipe suitable, and even advantageous in some cases.

For large-scale optically coupled microcircuits the use of individual sources separate from the receivers is cumbersome. Use of integral sources is not only advantageous but a necessity. This objective can probably be achieved with an epitaxial layer of an efficient electroluminescent material on silicon. Gallium phosphide is closely similar to silicon in lattice dimensions, but is not an efficient light-producing material. However, a mixture of gallium phosphide with 50 percent or more of gallium arsenide is an efficient electroluminescent composition.^{14, 15} An epitaxial growth on silicon of gallium phosphide grading to the desired composition is a means of reaching the goal. The resulting material is one on which the microcircuit technology, including photoreceivers, could be carried out and on which light sources will be integral.

Work related to this article was supported in part by the Aeronautical Systems Division, Air Force Systems Command under contract AF 33(657)-8678.

REFERENCES

- (1) M. Wolf, Limitations and Possibilities for Improvement of Photovoltaic Solar Energy Converters, Part I: Considerations for Earth's Surface Operation, *Proc IRE*, 48, p 1,246, 1960.
- (2) A. G. Chynoweth and K. G. McKay, Photon Emission from Avalanche Breakdown in Silicon, *Phys Rev*, 102, p 369, 1956.
- (3) M. A. Gilleo, Photonics: The Generation of Light in Silicon P-N Junctions and the Optical Coupling of Semiconductor Devices, Technical Documentary Report No. ASD-TDR-63-606, Contract AF 33(657)-8678, U. S. Air Force.
- (4) W. P. Dumke, Spontaneous Radia-

tive Recombination in Semiconductors, *Phys Rev*, 105, p 139, 1957.

(5) A. G. Chynoweth, Bell Telephone Labs., Inc., private communication.

(6) R. J. Keyes and T. M. Quist, Recombination Radiation Emitted from Gallium Arsenide, *Proc IRE*, 50, p 1,822, 1962.

(7) G. Cheroff, F. Stern, and S. Triebwasser, Quantum Efficiency of GaAs Injection Lasers, *Appl Phys Letters*, 2, p 173, 1963.

(8) R. E. Morrison, Reflectivity and Optical Constants of Indium Arsenide, Indium Antimonide, and Gallium Arsenide, *Phys Rev*, 124, p 1,314, 1961.

(9) H. B. Briggs, Optical Effects in Bulk Silicon and Germanium, *Phys Rev*, 77, p 287, 1950.

(10) P. Aigrain, Light Emission from Injecting Contacts on Germanium in the 2_u to 6_u Band, *Physica*, 20, p 1,010, 1954.

(11) M. A. Gilleo, to be published.

(12) S. S. Flaschen, A. D. Pearson, and W. R. Northover, Low Melting Sulfide-Halogen Inorganic Glasses, *J Appl Phys*, 31, p 219, 1960.

(13) R. P. Riesz, High Speed Semiconductor Photodiodes, *Rev Sci Instr*, 38, p 994, 1962.

(14) J. W. Allen and M. E. Moncaster, Injection Electroluminescence in Gallium Arsenide-Phosphide Alloys, *Phys Letters*, 4, p 27, 1963.

(15) N. Holonyak, Jr., and S. F. Bevacqua, Coherent (Visible) Light Emission from Ga(As_{1-x}P_x) Junctions, *Appl Phys Letters*, 1, p 82, 1962.

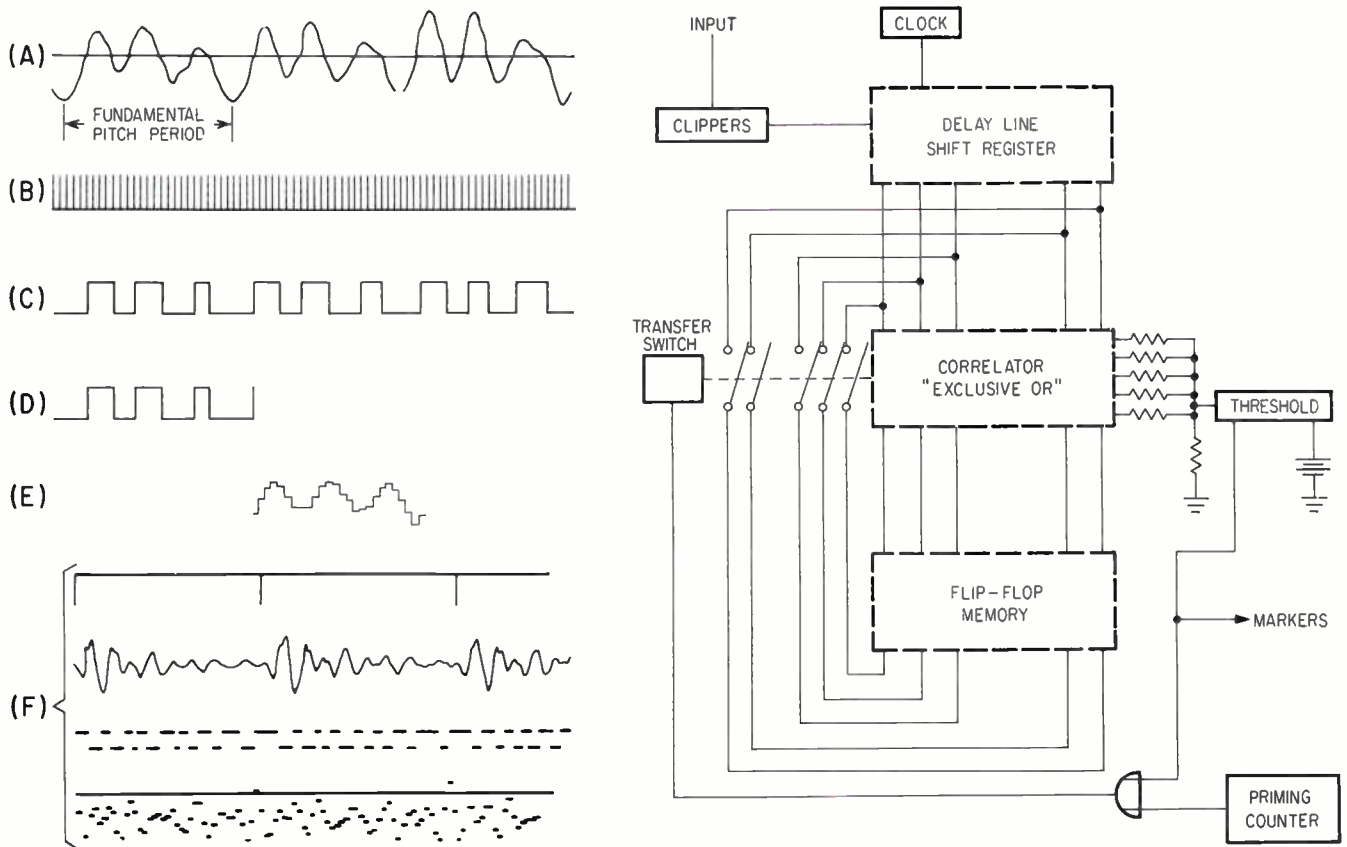

DIGITAL CORRELATOR operates on infinitely clipped voice signals sampled at 5 kc. A typical waveform (A) is sampled at clock rate (B) to produce waveform (C). Waveform (D) is stored, then compared with following waveform. Computed mismatched bits produce waveform at (E). Continuous operation produces waveforms (F), with fundamental pitch shown at top of (F)—Fig. 1

Digital Correlator Detects Voice

Of the various ways of determining the fundamental pitch of a voice waveform, digital correlation filters are the newest. Digital techniques are not infallible but they can be used in combination with other techniques to improve vocoder performance

TELL IT TO THE MACHINES

Machines controlled by spoken commands have long been one of the goals of technology, even though the possibility of building such sophisticated devices or even the need for them has seemed remote. The idea of talking to a typewriter and having a letter emerge instantaneously is highly appealing, despite sober second thoughts that secretarial filtering could be improving the signal to noise ratio more than suspected.

Nevertheless, a control tower operator might like to be able to tell a computer to investigate a possible collision course of two planes or to tell it to control air traffic during an emergency landing. Such possibilities are now beginning to materialize, and vocoder development is one key area



VOICE FUNDAMENTAL detector (left) is also used for cross correlation with fixed binary patterns. The bank of switches are used to enter fixed patterns into the memory

Fundamental

By R. B. STONE and G. M. WHITE
General Electric Company Research Laboratory, Schenectady, New York

IN SPEECH-BANDWIDTH compression systems using vocoder techniques, determination of the vocal cord vibration frequency or fundamental pitch must often be deduced from a signal whose fundamental frequency has been removed by filtering. This often occurs when the voice signal is brought in over a narrow bandwidth telephone line. Under these conditions the fundamental must be determined from its remaining harmonics. Certain of the harmonics will be dominant because of the resonant cavities formed by the mouth, tongue, lips and nasal cavity of the speaker and may lead to false measurements. The two to three octave band over which fundamental pitch often ranges during normal speech causes further difficulties. A typical speech

wave during voicing, with the fundamental pitch period indicated, is shown in Fig. 1A. A peak detector with avc could determine the fundamental pitch of this wave but would fail on certain other wave shapes.

Pitch detectors built since the introduction of the vocoder in 1939^{1, 2, 3, 4, 5, 6} can be classified roughly as peak detectors, tracking filters, low-pass filters, and correlation devices. The system described here uses correlation but operates in real time on clipped speech data, rather than using a digital computer for simulation as is typical.

Speech has the interesting property that if all amplitude information is removed—that is, the wave is infinitely clipped—intelligibility is retained. The waveform can be

further reduced while maintaining intelligibility if the infinitely clipped waveform is sampled synchronously at 5 kc or higher.⁷ Speech in this form can be represented by binary numbers where the output is a ONE if the original waveform was positive at the sampling time and ZERO if it was negative. This binary signal, while lacking some of the information contained in the original, allows the use of digital processing techniques operating in real time. Fundamental pitch information is also retained after this distortion and can be recovered with digital circuits.

Operating Principles—A typical example of a spoken vowel is shown in Fig. 1A, with fundamental pitch indicated. The waveform is reduced

to binary form, Fig. 1C, by sampling the polarity at discrete clock times, Fig. 1B. At each pulse from the clock the output is set to ONE or ZERO, depending on whether the polarity of the wave is positive or negative at that time, where polarity indicates whether the wave is above or below the long term average value. Fundamental pitch period is not as readily discernible by eye in binary waveform as in analog waveform. Binary correlation techniques, however, show that the information is still there. If the first n bits of the waveform of Fig. 1D are stored and compared with each subsequent set of n bits of the waveform, and the number of mismatched bits is computed for each comparison (Fig. 1E), a minimum at the fundamental pitch period will be reached that tends to be less than other minima. If that point on the waveform is marked, a new sample taken and the process continued through the word, each mark should be separated from the preceding mark by the fundamental pitch period. Taking a new sample each time minimizes errors that would be caused by gradual changes in the repeating waveform during the word.

The device is thus similar to a self-adapting filter.^{8,9} Elements in the block diagram of Fig. 1 are the binary counterparts of the same elements in an adaptive filter. An important difference in the binary mode of operation is the absence of averaging in the memory. Averaging, which is important in adaptive filters where the signal-to-noise ratio is low, is not needed or desired in a fundamental pitch detector since the signal changes rapidly with time and background noise is relatively low.

The priming circuit, Fig. 1, activates the transfer circuit, which takes the contents of the delay line shift register at that time and stores it in the flip-flop memory. The signal is shifted down the shift register by the clock pulses. A new signal bit is introduced with each shift and the oldest one is discarded. After every shift each *exclusive or* circuit determines if the corresponding bits on the shift register and in the memory do not match. An analog sum of the *exclusive or* circuits, which is proportional to the number of mismatched bits, is computed and compared with a

threshold. When the analog sum drops below the threshold, the transfer circuit is activated on the occurrence of the first minimum. The process then continues, as indicated in Fig. 1F. Marker pulses are generated and memory is updated each time the analog sum reaches a minimum below the threshold. The memory register thus contains a recent sample of the signal while the

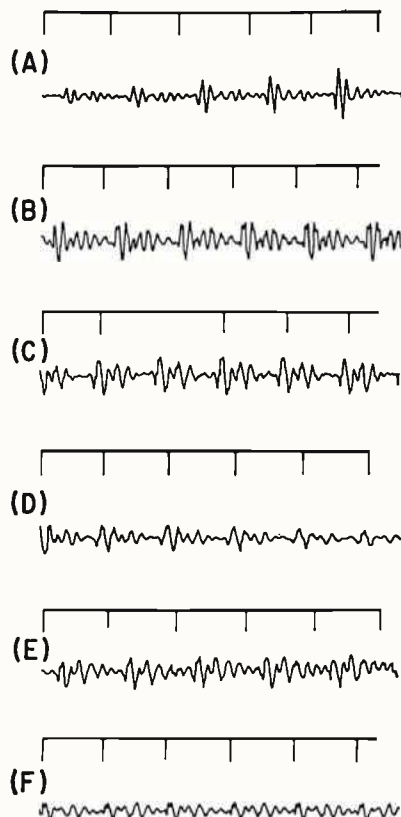

SAMPLES of waveforms and detected fundamental pitch: waveforms (A) show tracking through a drastic change; waveforms (B) would not be successfully analysed by a typical peak detector, and (C) shows a failure by the digital system. Other representative waveforms at (D), (E) and (F)—Fig. 2

transfer pulses indicate the sequence repeat period. The priming circuit operates again only if no threshold crossings occur during a preselected length of time. This device was constructed with 500-kc modules and operates in real time on speech; much slower devices could be used since the clock rate is only 5 kc.

Performance—In Fig. 2A the fundamental pitch is tracked through a fairly drastic change in the waveform; Fig. 2B shows a waveform that would cause an analog peak

detector to fail because of the double peak but is successfully analysed digitally.

In Fig. 2C, on the other hand, the digital device erred where a peak detector would have no difficulty. Since the repeat period of the waveform is not an exact multiple of the clock period, polarity samples will not be taken at the same points on the waveform each time it repeats. Mismatches due to this lack of synchronization may occasionally cause the minimum number of mismatches to be above the threshold. These errors could be reduced by increasing the sampling rate while increasing the length of the delay line and memory correspondingly to cover an equal length of the waveform.

A more serious but less frequent difficulty occurs when the zero crossings are nearly equidistant (as in the example 000111000111000-111—). In this case there are false indications when the fundamental pitch occurs, and nothing can be done to correct this type of error.

Despite these difficulties the error rate of the device is low. Waveforms which cause difficulty in this device would usually be correctly processed by a peak detector and vice versa. Therefore, while neither device works perfectly, an extremely low error rate should be possible by operating the two devices together.

An analog adaptive filter rather than the binary version described here might appear to offer improved performance. But the error rate for a filter of equal length simulated on a digital computer was not noticeably lower and little would be gained with a more complicated analog version of the system.

REFERENCES

- (1) H. Dudley, Remaking Speech, *J Acous Soc*, 11, 2, 1939.
- (2) L. Dolansky, An Instantaneous Pitch Period Indicator, *J Acous Soc*, 27, 1955.
- (3) O. O. Gruenz and L. O. Schott, Extraction and Portrayal of Pitch of Speech Sounds, *J Acous Soc*, 21, 1949.
- (4) B. Gold, Computer Program for Pitch Extraction, *J Acous Soc*, 34, 1962.
- (5) T. Sugimoto and S. Hashimoto, The Voice Fundamental Pitch and Formant Tracking Computer Program by Short Term Autocorrelation Function, 1962 Stockholm Speech Communication Seminar.
- (6) H. Fujisaki, Automatic Extraction of Fundamental Period of Speech by Autocorrelation Analysis and Peak Detection, *Acoustical Society Meeting*, Oct. 1960.
- (7) J. C. R. Licklider, Intelligibility of Amplitude-Dichotomized Time Quantized Speech Waves, *J Acous Soc*, 22, 6.
- (8) C. V. Jakowatz and G. M. White, Self Adaptive Filter Finds Unknown Signal in Noise, *ELECTRONICS*, Feb. 17, 1961.
- (9) E. M. Glaser, Signal Detection by Adaptive Filters, *PGIT*, IT-7, 2.

COUNTER frequencies and rise times demand careful circuit layout and miniaturization to minimize parasitics

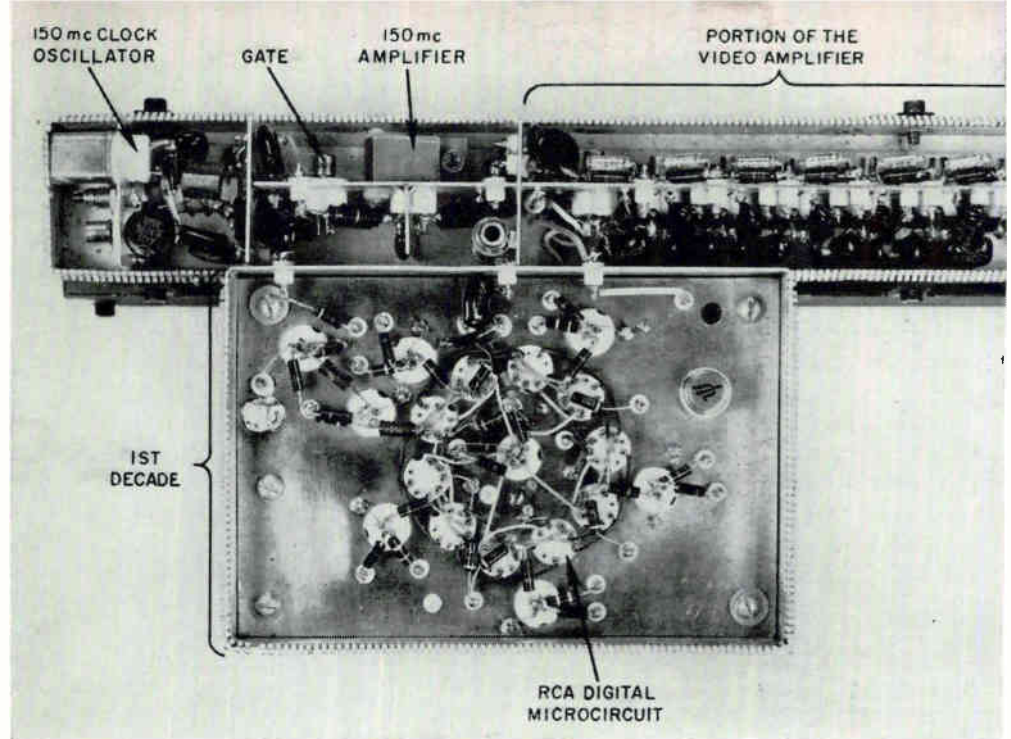

USING MICROCIRCUITS IN

High-Resolution Range Counters

High-frequency decade of this counter is a digital microcircuit to save space and power. Snap-off diodes designed into the driver help produce pulse widths of about 2 nanoseconds at clock rates as high as 250 Mc

By **L. C. DREW**
Systems Support Engineering,
Radio Corp. of America,
Burlington, Mass.

REAL-TIME RANGING SYSTEMS

One of the problems of rendezvous in space is determining distance between vehicles. Here is a range counter which operates at a 150-Mc clock rate or ± 1 meter resolution. It has operated successfully in stringent environments and shows promise for satellite docking, surveying and long range determinations

RANGING SYSTEMS of high resolution can be built, if the latest in circuit techniques and devices are designed into compatible circuits. Here is a range counter system operating at 150-Mc clock rate or ± 1 meter resolution. Typical of the advanced techniques used: a digital microcircuit as the 150-Mc first decade; and, snap-off diodes in the critical high-frequency driver. The feasibility model of this counter system has operated successfully under environmental conditions similar to military specs, and shows promise for many uses, both here on earth and in space.

The block diagram (Fig. 1) shows a straight-forward counter with a gated clock controlled by start-stop pulses. Counter time reference is a crystal-controlled oscillator whose period corresponds to desired range resolution. If desired range interval is ± 1 meter, the

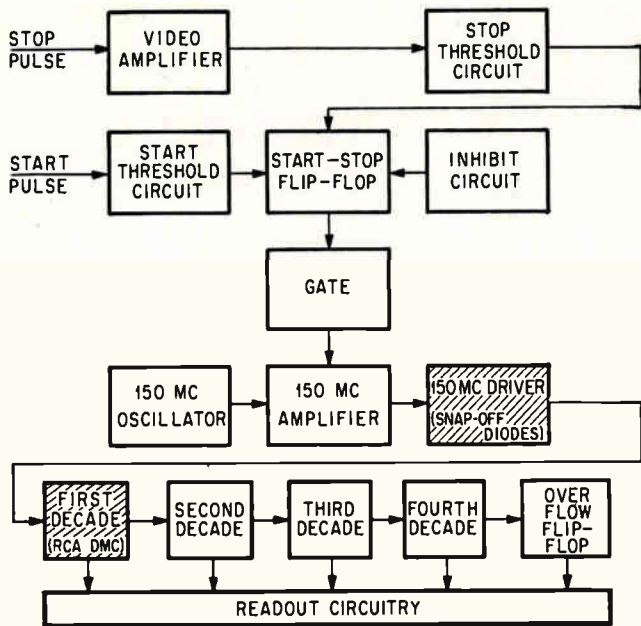

COUNTING SCHEME is normal, but critical 150-Mc driver turns off and recovers in under 3.5 nanoseconds. Snap-off diodes do it. First decade is digital microcircuit—Fig. 1

oscillator must operate at 150 megacycles. Oscillator output is gated to the counting circuits by the start-stop flip-flop. This flip-flop is turned on by a start line pulse and turned off by a stop line pulse.

The counting flip-flops are arranged into decades. Each decade has reached some count when the stop pulse occurs. When the start-stop flip-flop goes off, a 0.8-second one-shot multivibrator is started. This initiates the readout period resulting in each decade count being presented on a separate Mageline readout. Each decade count is converted, by relays, to an appropriate drive signal for display. Once the display has reached final readout position, no further maintaining power is required; this provides infinite type storage. As a result, all power can be removed from the readout circuits when the one-shot period is over. An overflow flip-flop is also included, to indicate the lack of a return pulse to stop the counter. When the counter has reached its maximum capacity, the overflow flip-flop indicates that the reading obtained is invalid. The inhibit flip-flop prevents the counter from being turned off before an adjustable length of time. After this time, the inhibit flip-flop changes state, allowing the next stop line pulse to turn off the start-stop flip-flop. The inhibit flip-flop insures that noise external to the system, which can be high enough to turn off the counter, will not negate the function of the system. Complete counter reset is automatic, with manual reset included.

Circuits—Counter system high frequencies and fast rise times demand careful component selection and circuit construction. Circuit configurations must optimize the performance of all devices. Careful mechanical layout and miniaturization minimize parasitic inductance and capacitance. Shunt feedback, as an example, is used around each stage of the video amplifier, causing low input and output impedances

which, in turn, require extremely short leads to minimize stray inductance. In Fig. 1, the high-frequency circuits to note are—the clock-oscillator, amplifier and gate, the video amplifier, and the high-frequency or first decade of the counter and its driver.

Since the maximum possible range of the counter is 9,999 meters (four decades) and resolution is ± 1 meter, the oscillator should have a stability of one part in 10^5 . This insures the maximum error to be the counter error of ± 1 cycle. Therefore, the 150-Mc oscillator must be a crystal-controlled oscillator. A seventh overtone crystal oscillator was chosen, over a lower frequency oscillator and multiplier, because it conserves space and power.

The 150-Mc amplifier is necessary for two reasons—it acts as a buffer; and it is able to provide at least 3 volts peak at driver input. A grounded-base stage, with matching network, is used on both input and output for good isolation. Several methods are explored in gating this amplifier, only one was successful. Main cause for failure—the impedance of a saturated transistor or diode is not low enough, at 150-Mc, to act as a shunt or series switch, and so causes on and off levels to be nearly equal.

Figure 2 shows the 150-Mc clock-gate, amplifier, and driver. The gate-amplifier circuit uses a current-robbing technique for operation. When the gate transistor Q_1 (2N2368) is turned on, the emitter of Q_2 is held positive: Transistor Q_2 is off providing more than adequate isolation. This method also proved capable of switching from one state to another within one cycle of the clock, preserving counter resolution.

Video Amplifier—Included in the stop line is a 60-db, 200-Mc bandwidth current amplifier, to handle the low-level stop pulse (as low as 2-8 μ amp). The 200-Mc bandwidth preserves stop pulse rise time and counter resolution.

This video amplifier has its gain time programmed (tpg) from the start-stop flip-flop to reduce false triggering. This tpg circuit, similar to agc, allows amplifier gain to range from approximately unity (at time = 0) to full gain at maximum range. This is possible since the stop line signal strength varies inversely with time. This time-programmed function is achieved by controlling, with RC networks, the conductance through a set of diodes in shunt with the input.

The basic video amplifier was designed with six stages, using individual parallel voltage feedback and emitter degeneration and peaking. This approach produced the desired bandwidth (200-Mc) and approximately 54-db of gain. In addition, a common-emitter input stage (providing an added 6-db gain) was included to reduce the input impedance to its lowest possible value. Using 2N918 transistors biased at optimum operating point, the video amplifier achieved the desired characteristics.

The output of this video amplifier drives a threshold device (diode-transistor gate) which, when threshold is exceeded, provides a pulse to trigger the start-stop flip-flop. Since the start line has a similar threshold device, the differences in delay, approximately 15 nanoseconds, in the start and stop line are caused primarily by the video amplifier.

Decade Operation—The first decade accepts the clock rate of 150-Mc, with each flip-flop within the decade operating at $\frac{1}{5}$ the bit rate. A typical 5-stage decade, consisting of five flip-flops and ten AND gates, is shown in Fig. 3A. The flip-flop outputs are cross-coupled to opposite input gates in a ring formation. Figure 3B illustrates the idealized output waveforms of each flip-flop.

The counter (3A) is shown in the reset position with all right sides on, and the clock line held to ground. The various gates are enabled by the off side of the previous flip-flop in the ring and the input positive clock pulse.

The left side of the first stage is turned on by the first pulse, which enables the left side gate of the next flip-flop such that the second pulse will turn off the second stage, etc. If the input signal gets through a gate, it can only turn a flip-flop from 1 to 0. If the flip-flop is already in the on state, no switching can occur. Thus there are four enabled gates which do not switch as their flip-flops are already in the on state. Each succeeding input pulse switches a succeeding stage off until the fifth pulse. The sixth pulse starts again with the first stage, turning it on. Succeeding pulses turn on succeeding stages until the counter is back in the reset position after the tenth pulse. According to Zoltan Tarczy-Hornoch¹ and our experimental tests, this scheme depends primarily on gate sensitivity and rise time, not on flip-flop speed.

Critical Driver—The counter's most critical feature is the driver (Fig. 2), which must turn off and recover within one cycle of the clock rate. The propagation-rise-fall time, as well as the pulse width, must be less than one-half cycle or approximately 3.5 nanoseconds. Since the driver transistor is biased in the saturated condition, the above conditions are difficult to achieve. Using snap-off diodes, drivers were designed capable of producing a pulse width, at the base, of approximately 2 nanoseconds at a clock rate as high as 250-Mc. This driver circuit is normally saturated holding the clock line grounded. Both the FD600 and the SSD558 are snap-off diodes. They reshape the incoming 150-Mc sinewave to a fast rising negative pulse which turns off the 2N709. This produces the fast positive clock pulse necessary to trigger the TTL flip-flop. The snap-off diodes are necessary for pulse shaping to take advantage of the 2N709 optimum switching speed.

The normal minimum sensitivity of the driver is 2-3 volts peak; however, it will operate more reliably with a 4-6 volt input. Such a driver was developed and used with the above counting scheme to successfully test a 250-Mc counter, insuring reliable counting circuits in this 150-Mc counter.

Microcircuits—Using the above logic scheme, various circuit designs of the gates and flip-flop were tried—namely, RCTL, DCTL, RCTL in a current mode, and TTL. All appeared to operate successfully, however, the TTL was deemed the most feasible, and packaged in the RCA digital microcircuit format (RCA DMC), because it conserves power and space. The packaging technique was also found to increase the speed of previous breadboard counters by a factor of almost 2.

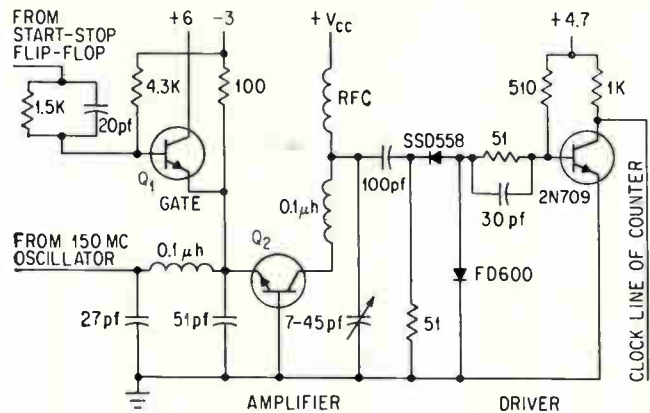

CURRENT robbing gate-amplifier operation makes the amplifier a good buffer. Driver snap-off diodes shape fast negative pulse turning off 2N709; sends fast positive trigger to first decade—Fig. 2

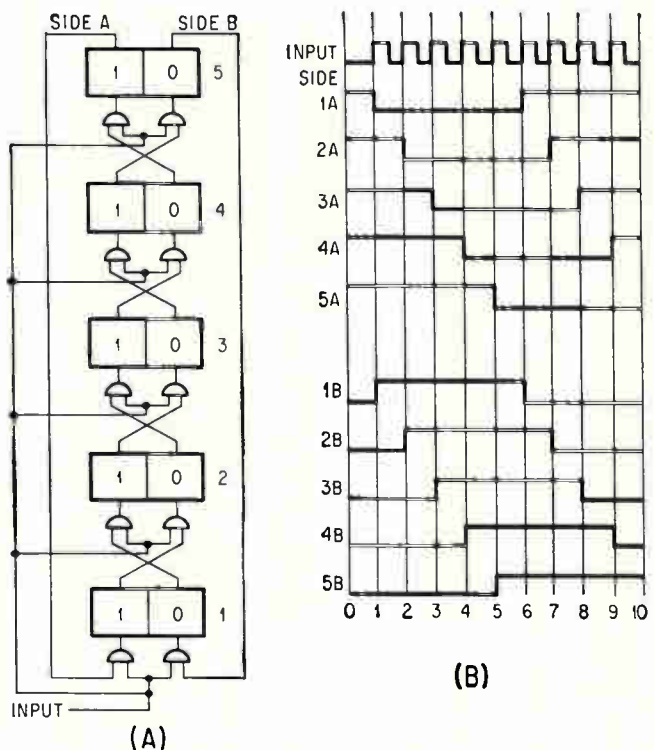

DECADE COUNTER stages (A) in reset condition or side B conducting. Output waveforms (B) of flip-flops—Fig. 3

The other three decades of the counter, consisting of 4 flip-flops each, use a conventional, universal RCTL flip-flop.

The readout of all four decades is performed by the output of each flip-flop driving a relay driver. The relay contacts form the decoding logic, switching each Magneline readout unit to the proper decade number.

The author thanks Harold F. King and Donald H. Landry for their assistance in this article.

REFERENCE

(1) Zoltan Tarczy-Hornoch, "Five Binary Counting Technique Makes Faster Decimal-Counting Circuits," *Electronic Design*, Jan. 1961.

How Coded-Pulse Techniques Extend Radar Range

Experimental system uses a wide transmitted pulse with low repetition rate and increases resolution by phase modulating the transmitted pulse carrier

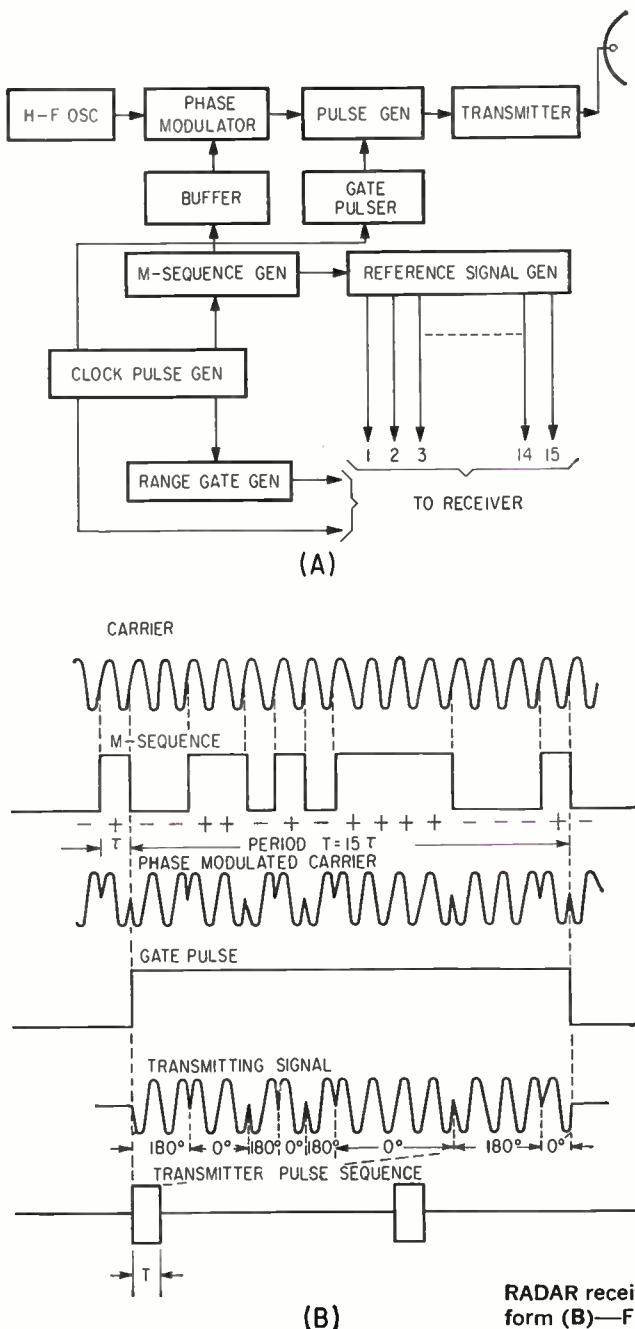

By T. SAKAMOTO, Y. TAKI, H. MIYAKAWA and H. KOBAYASHI
Faculty of Engineering, University of Tokyo

T. SUZUKI, University of Electrical Communication, Tokyo

T. YOSHIDA, T. TAKEYA and M. KOKUBU
Toshiba Electric Co. Ltd., Tokyo, Japan

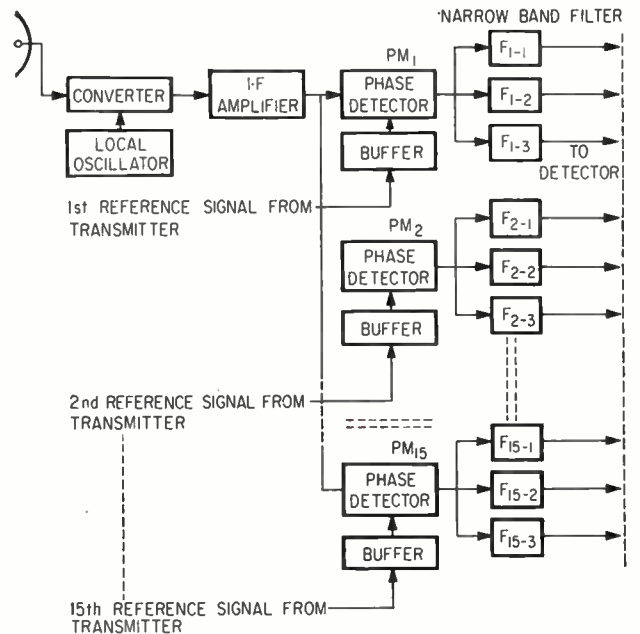
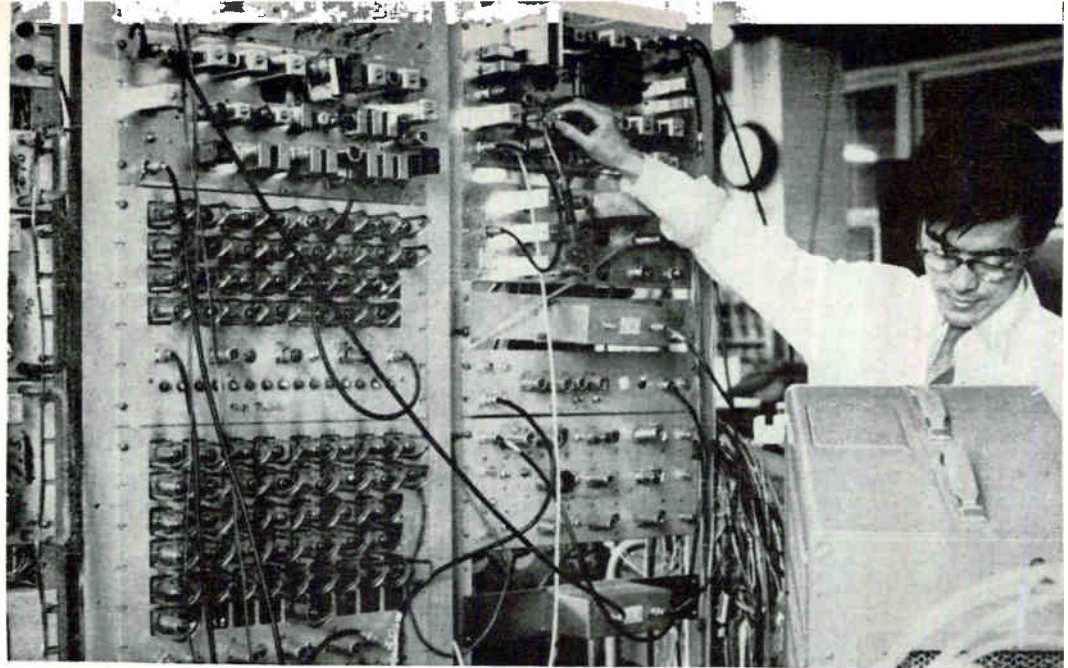

DIAGRAM of the receiving system including narrow-band filters—Fig. 2

RADAR receiver (A) and generation of the transmitted waveform (B)—Fig. 1

RESEARCH ASSISTANT adjusts the top stage of the coded-pulse radar receiver



INCREASING complexity of modern warfare has resulted in a need for sophisticated techniques for long-distance target detection. Simple radar systems have range limitations imposed by average radiated power, and resolution is limited by pulse length and beamwidth acquisition time.

During World War II, principal emphasis in the development of radar techniques and components was centered on increasing range and range resolution performance by higher transmitted peak power and reduced pulse length. As a result, the efficiency of high-power tubes is still often too low in terms of average power. While post-detection integration techniques have been developed to compensate for this inefficiency and extend radar range, they often lead to further losses in the use of total available average power.

Improved Performance—The chirp scheme,^{2,3} which employs linear frequency modulation, represents one method with which desirable high-resolution properties may be secured with optimum equipment utilization. However, this technique, like conventional radar methods, possesses an inherent ambiguity in simultaneous determination of both the range and velocity of a moving target.⁴

To obtain improved long-range radar performance, not only must a wide pulse with large total power be employed, but the product of signal bandwidth or duration (time-band-

width product) must be large. Moreover, the ambiguity function (radar response function) should be sharply defined and have low side-lobe level. In accordance with these requirements, a coded-pulse radar was proposed for long-range applications⁶ and lab experiments were performed to demonstrate its principle.

Operation—The desired radar system had to provide both range and doppler information. The system designed utilizes a wide transmitted pulse with a low repetition rate. High resolution is accomplished by modulating the phase of the transmitted pulse carrier. Pseudo-random sequence is generated with a feedback shift register as a modulating signal.

A wide r-f pulse with width T is generated by a crystal oscillator, where the carrier pulse is phase modulated by a pseudo-random signal from a sequence generator. A block diagram of the transmitter is shown in Fig. 1A, while the signal waveforms appear in Fig. 1B. The top waveform in Fig. 1B is that of the unmodulated r-f pulse; the second the pseudo-random sequence derived from the sequence generator¹ that is similar to a feedback shift register; the third waveform represents the phase-modulated carrier; the fourth, the gate pulse; the fifth, the transmitted signal and the last waveform the transmitter pulse sequence.

At the receiver, the signal reflected from the target is phase

modulated by a replica of the pseudo-random signal used in the transmitter as shown in Fig. 2. The first local reference signal (lrs) is the replica of the pseudo-random signal without delay. The second lrs signal is the replica with one unit of delay corresponding to one code element or one cycle of the feedback shift register. In the same manner, the n -th lrs signal becomes the replica of the pseudo-random signal with a delay of $(n-1)$ units.

The demodulated signal is supplied to the filter bank, which consists of a number of narrow-band filters each having a bandwidth of $1/T$. For moving targets, the doppler effect produces a frequency difference between the transmitted and received pulse. Since doppler shift is not known beforehand, it is necessary to be prepared to process an echo that occurs anywhere within a wide bandwidth. The filter bank discriminates between the reflected signals and those from targets of different velocities. A number of local reference signals with different delays will discriminate between signals reflected from targets in different positions. The principle of velocity and position discrimination is shown in Fig. 3A and 3B.

The signal waveforms involved in the detection process are shown in Fig. 3A for a zero time difference between reflected signal and lrs signal. Here, the output of the phase modulator is a continuous wave without phase modulation. If there is no doppler shift, the output of the

first filter in which signal appears indicates the presence of a target. The other channels yield only small outputs.

For nonzero time difference between reflected and local signals, the waveforms for detection appear in Fig. 3B. Here, the output of the phase modulator is a phase-modulated sinusoidal wave. Because the pseudo-random sequence is derived by the maximal length or M-sequence feedback shift register, the number of units with a plus-phase of the demodulated waveform is almost equal to that of the minus phase. Since the pluses and minuses cancel, none of the filter outputs builds up sufficiently. This is also explained by the fact that each filter in the bank has a narrow bandwidth.

Filter-bank outputs are fed to envelope detectors. To further extend target-detection range, the double-threshold method of detection was used as a means of post-detection integration.^{5,7} Figure 3C illustrates the basic principle of this method.

The pseudo-random signal used to modulate the transmitted pulse has a period T that equals the transmitted pulse width. According to the theory of correlation detection, this prevents the unambiguous measurement of any delay time larger than T . Considering that the transmitted pulse length is T , this ambiguity is eliminated by the range gates that are inserted after the envelope detector. These gates have identical repetition frequency as the transmitted pulses and are arranged

so that their time differences are equal to transmitted pulse width. Therefore, the output of the first gate indicates the existence of the reflected signal with a delay between T and $2T$ etc.

Output—The first threshold detector quantizes the output of the envelope detector into 0 to 1. The succeeding counter integrates the number of 1's during a certain time interval. Should this number exceed the second threshold, the alarm signal will be obtained. The double-threshold method of detection makes possible the application of digital techniques to the detection process to stabilize the system by eliminating various external disturbances.

Figure 4 shows the waveforms involved in the detection process for zero time difference between reflected and local reference signals. In these photos, the lab model used a carrier frequency of 1.9 Mc, a pulse repetition frequency of 100 cps, a pulse width of 1 millisecc and a pseudo-random sequence of 15 for modulation.

A fifth-order, maximally-flat-delay LC filter with a 3-db bandwidth of 760 cps and a center frequency of 100 kc was used for the narrow-band filter. According to results obtained, the doppler shift⁵ of ± 300 cps has negligible effect on the output amplitudes. Moreover, a doppler shift of ± 600 cps gives 6 db attenuation and a shift of ± 900 cps gives nearly zero output.

Waveforms for nonzero time difference between reflected and local signals are shown in Fig. 5A. They illustrate the incomplete buildup of the output waveform of a narrow-band filter. Observations made for each time difference between local and reference signals resulted in the ambiguity curve of Fig. 5B where the ordinate shows the relative amplitude of the narrow-band filter output. The unit k represents one cycle of the feedback shift register. From these results, the poorest discrimination factor is 0.3, while this factor is better than 0.2 over the wide range of k . The peak at the origin indicates the true coordinate of a single target, with the response falling off sharply from the origin. According to theory, the sharpness of the peak depends upon the bandwidth of the modulating signal. Increasing the maximal period of the

LONG RANGE THREAT

Modern aircraft and missiles operate at speeds so high that they must be detected at far greater ranges than necessary just a few years ago. While the coded-pulse radar technique described is not at present being commercially produced, the authors feel that their investigations into this technique demonstrate that it offers substantial radar range extension and image resolution increase. Moreover, they feel sure that research of this type will result in even greater improvements of the state of the art

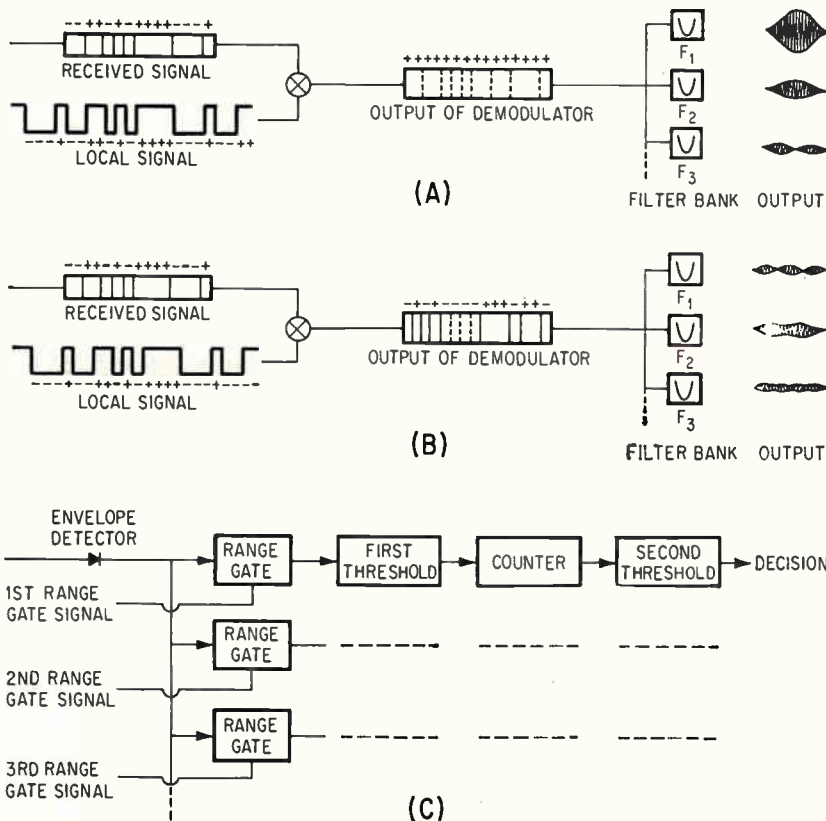

METHOD of correlation detection for zero delay (A), for nonzero delay (B), and the double-threshold detection scheme (C)—Fig. 3

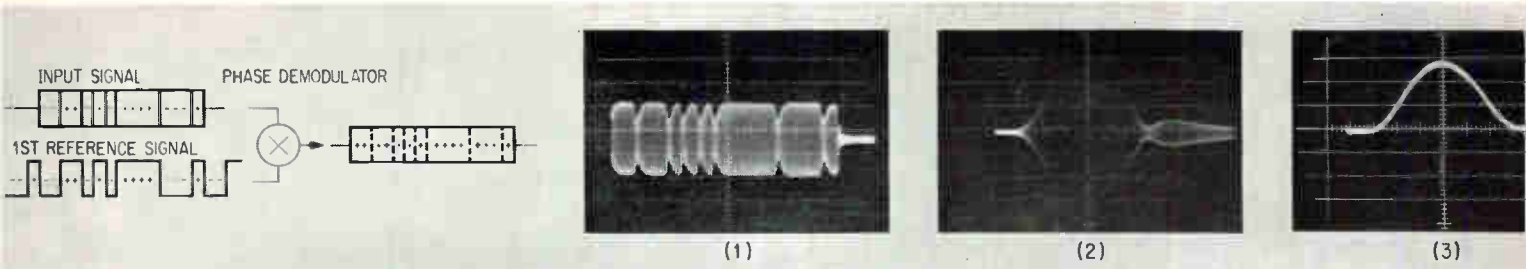

SCOPE PHOTOS showing the output of the phase modulator (1), output of the narrow-band filter (2) and the linear-detector output (3) for zero-delay correlation detection as in Fig. 3A—Fig. 4

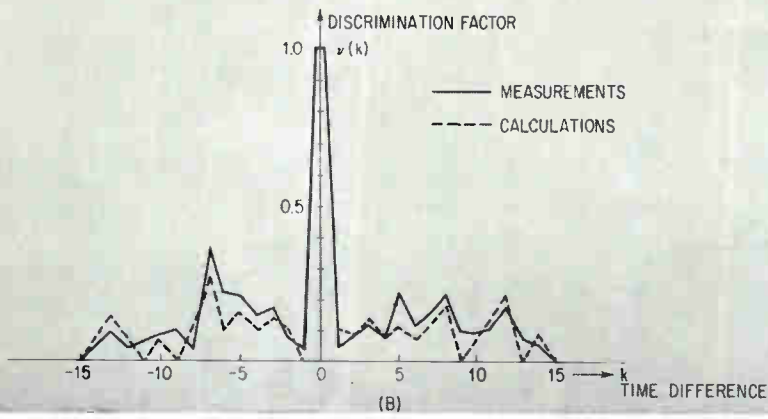
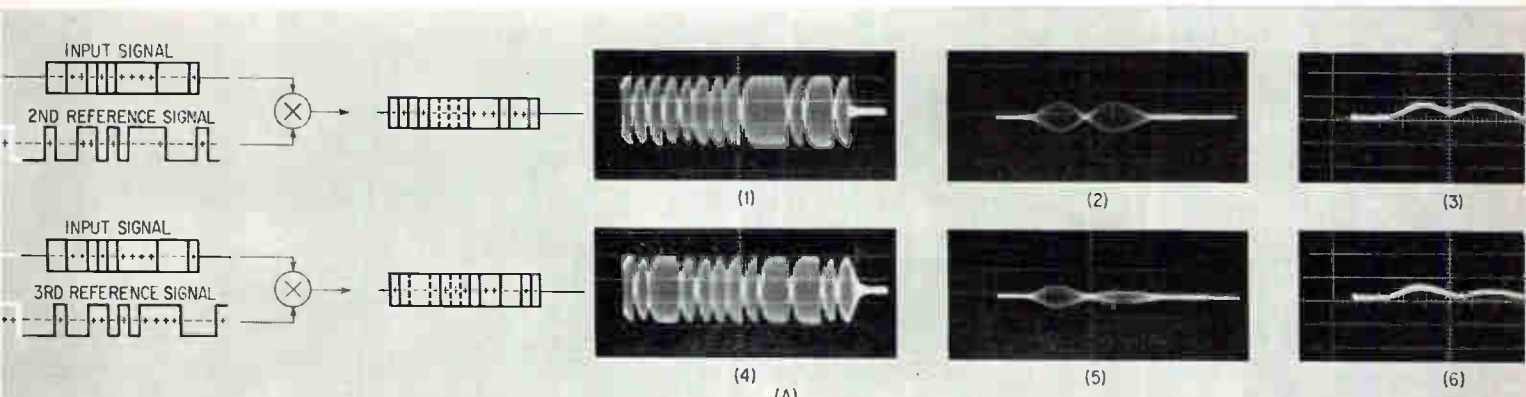

WAVEFORMS corresponding to the detection scheme shown in Fig. 3B, where photos 1 and 4 show the output of the phase modulator, 2 and 5 are narrow-band filter outputs and 3 and 6 are linear detector outputs (A) and ambiguity diagram showing discrimination factor vs time difference (B)—Fig. 5

pseudo-random sequence derived from a feedback shift register results in an indefinite increase in peak sharpness. For a specific sequence with a length of 15, spurious peaks appear at $k = -7, k = 5$, etc. It seems logical that these peaks can be further decreased by employing a pseudo-random sequence with a larger maximal period. Furthermore, the magnitude of spurious peaks can be reduced in practice with post-detection integration of successive radar responses. In this case, the sharpness of the origin peak will also be increased.

The authors would like to emphasize that this work represents experimental results of the response of one specific system. However,

they believe that proper waveform design can further improve the sharpness at origin and reduce the magnitudes of spurious responses.

REFERENCES

(1) D. A. Huffman: "The Synthesis of Linear Sequential Coding Network", Information Theory, The Third London Symposium, Sep. 1955.
 (2) C. E. Cook: "Pulse Compression-Key to More Efficient Radar Transmission", *P.I.R.E.*, 48, 3, p 310, March, 1960.
 (3) J. R. Klauder, A. C. Price, S. Darlington and W. J. Albersheim: "The Theory and Design of Chirp Radars", *B.S.T.J.*, 39, 4, p 745, July, 1960.
 (4) J. R. Klauder: "The Design of Radar Signals Having Both High Range

Resolution and High Velocity Resolution", *B.S.T.J.*, 39, 4, p 809, July, 1960.
 (5) K. Endresen and R. Hedemark: "Coincidence Techniques for Radar Receivers Employing a Double Threshold Method of Detection", *PIRE*, 49, 10, p 1561, Oct., 1961.
 (6) W. Fishbein and O. E. Rittenback: "Correlation Radar Using Pseudo-Random Modulation", *IRE, Trans. on I.T.*, March, 1961.
 (7) J. V. Harrington: "An Analysis of the Detection of Repeated Signal in Noise by Binary Integration", *I.R.E. Trans. on I.T.*, March, 1955.

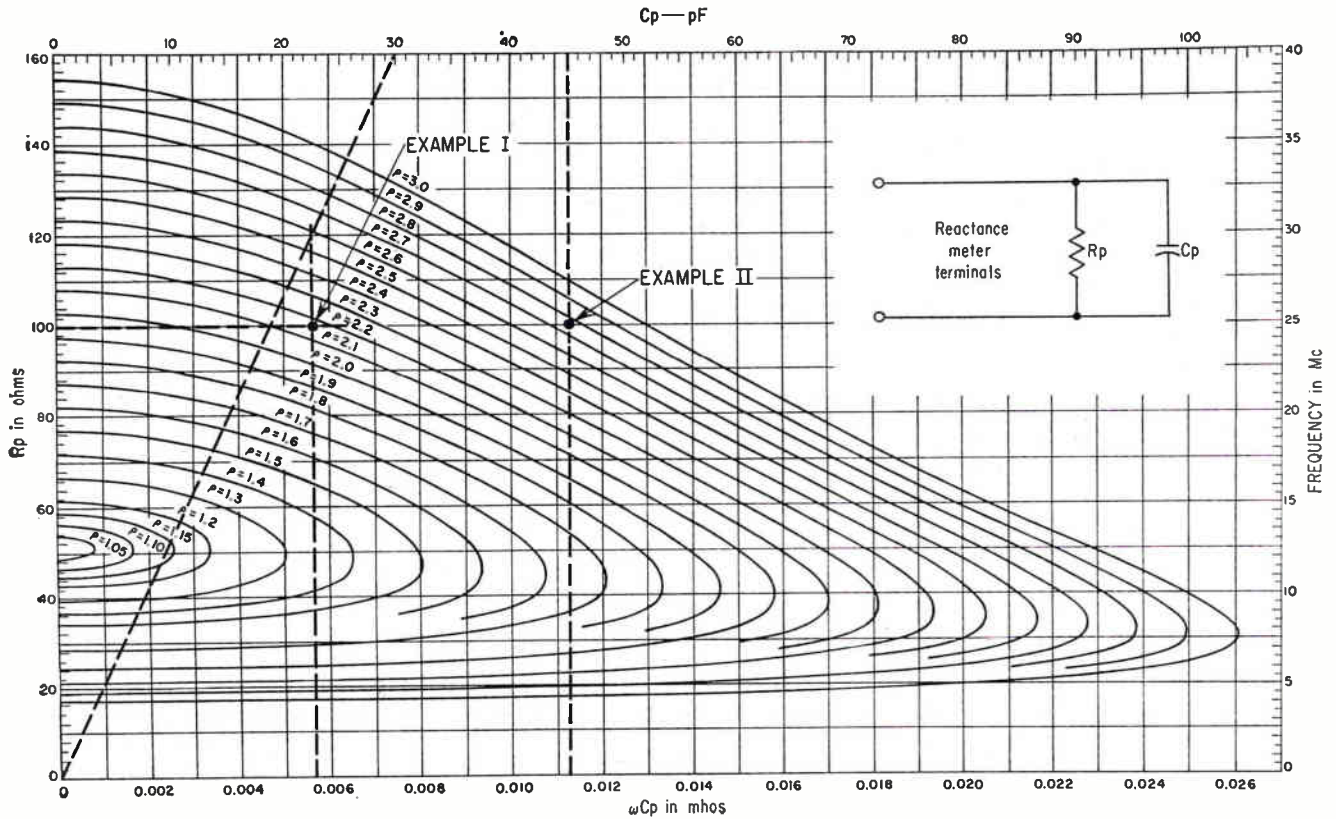

Easy-to-Use Chart for VSWR

By **GEORGE HAGN** and **BRUCE SIFFORD**.
 Communication Laboratory,
 Stanford Research Institute, Menlo Park, California

TRANSMITTER operating instructions often indicate a maximum voltage standing wave ratio (vswr) for the transmission line into which the transmitter may be loaded without damage. A typical maximum value for vswr is 3 to 1. For receiving applications, the vswr indicates the amount of power that the transmission line will accept from an antenna, thus, the vswr and not the actual impedance at the antenna terminals is of greater importance. The standard method of determining vswr, ρ , is to measure the impedance at the input of the line, (R_p), normalize by the characteristic (surge) impedance of the line, (R_o), and solve for vswr. This solution may be made either by formula or by plotting the normalized value on a Smith chart. Both of these methods are time consuming and subject to error.

This chart enables the simple calculation of vswr without the use of a sliderule. It requires readings directly from the dials of most r-f bridges with the shunt impedance in the unknown leg. Notice that the curves are symmetrical about the C_p equals zero line. Thus, C_p negative corresponds to an inductive

shunt reactance that can be expressed as an equivalent capacitive reactance (as done with the Boonton reactance meter). This symmetry permits plotting only half the chart without loss of generality.

Caution: This chart applies only to measurements made with lines having a $R_o \cong 52$ ohms (such as Army-Navy type RG 5 B/U, 8 A/U, 9 B/U, 10 A/U). Other values of R_o can be calculated from

$$R_p = \frac{R_o}{\left(\frac{\rho^2 + 1}{2\rho}\right) \pm \sqrt{\left(\frac{\rho^2 - 1}{2\rho}\right)^2 - (\omega C_p R_o)^2}}$$

Example 1: Lay straightedge from origin through measured value of $C_p = 30$ pf. Locate vertical line of constant ωC_p at intersection of straightedge with operating frequency line ($f = 30$ Mc). Read vswr ($\cong 2.17$) at intersection of ωC_p and line of measured $R_p = 100$ ohms.

Example 2: This chart was designed for use in the 3 to 30-Mc band. To use it at frequencies higher than 40 Mc, locate the ωC_p line, use the C_p scale line with $C_p = (f/40 \text{ Mc}) \times C_p$ (measured). Given: $C_p = 30$ pf, $f = 60$ MC and $R_p = 100$ ohms then $\rho \cong 2.76$.

We've got a better way



Polaroid circular polarizers are the best way to eliminate reflections from digital readouts. They improve readability from all directions, reduce glare from normal room light and increase contrast. You can see better from any angle even in brightly lighted rooms (and the registers certainly look better—no cardboard awnings). Many major instrument manufacturers are using cir-

cular polarizers in digital indicators now.

For complete information, write Polaroid Corp., Polarizer Div. ED-11, 119 Windsor St., Cambridge, Mass. In Great Britain: Polarizers (United Kingdom) Ltd., 26 Stamford Street, London S.E.1, England.

In Europe: Polaroid GmbH, Holzhausenstrasse 30, Frankfurt/Main, Germany.

updating in electronics for busy engineers

CREI Extension Programs
fit any schedule

Are irregular hours, travel and family obligations keeping you from attending classes—even though you are fully aware of the danger of technical obsolescence? Check into CREI Special Programs for Engineers. They offer you the opportunity to catch up with new developments in electronics through home study at your own pace, your own schedule. Our free brochure gives full information, details on technical material covered. For your copy, use coupon or write:

CREI, Dept. 3911-A1,
3224 Sixteenth St., N. W.
Washington 10, D. C.

FREE BOOK



The Capitol Radio Engineering Institute



Founded 1927 Accredited Member of
the National Home Study Council
Dept. 3911-A1, 3224 Sixteenth St.,
N. W. Washington 10, D. C.

Please send me free brochure describing CREI Special
Program in Electronics for Engineers.

Name _____ Age _____

Address _____

City _____ Zone _____ State _____

Company _____

Title _____

SP-41

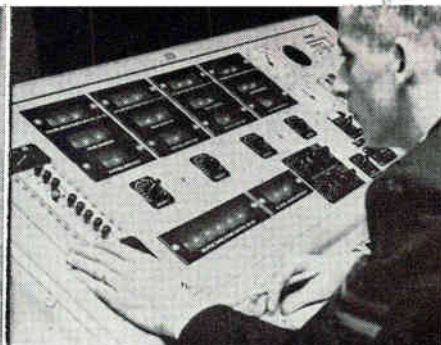

OPERATIONS trainer used by Canadian Navy has four ship's operation rooms (left). At right is air controller's console

Task Force Trains Ashore

Antisubmarine-warfare
teams use simulator to
practice air-sea attack

By JOHN M. CARROLL
Managing Editor

HALIFAX, NOVA SCOTIA — How do you teach the latest anti-submarine-warfare techniques to naval personnel in fleet schools and to radar-plotting teams of operational vessels, without the expense of sending a task force to sea?

The Royal Canadian Navy solved this problem with equipment designed by Sperry Gyroscope of Canada, Montreal. Installed at the Navigation Direction School (HMCS Stadacona) here, the equipment simulates the AIO's—Action Information Organizations (CIC rooms) — of four destroyers. One room can also stimulate an aircraft carrier's air-direction room. The AIO's are outfitted with standard RCN equipment including two optical x-y plotting tables and two ppi radar repeaters. On one plot table, a target-plot attachment shows the sub as a red dot and the escort as a green dot.

Task Force Simulation — An 18-man control staff in the control room feeds signals simulating radar, sonar, communications and other data to the AIO rooms. Trainer inputs consist of position, course and speed data for the four escorts and up to 28 targets. Escort data is entered by WRNS seated in the control room and reacting to orders from the respective AIOs. Other

control-staff members enter target data to formulate the tactical problem. The trainer's output is realistic radar and sonar data plotted in the control room and fed to each AIO—voice signals for sonar and radar-repeater displays.

Targets are: 10 submarines or surface ships with speeds from 0 to 40 knots, with subs submerged, surfaced or snorkeling; four helicopters moving at 0 to 120 knots; 14 aircraft with speeds up to 1,200 knots, altitude to 99,000 ft, and able to give Mark 10 IFF responses or jamming signals. Wind up to 80 knots from any direction can be simulated.

The control room has two plotting modes available: one 500 miles square; the other 12½ or 25 miles square. The units are represented by alphanumeric characters and their paths by comet-like tails. Heart of the simulator is a Packard Bell 250 computer and required analog-to-digital and digital-to-analog converters.

Control Display—The main control display is optically projected on a screen by photographing a crt face. Film processing takes 8 seconds. The crt displays dots representing the positions of escorts and targets. These dots are impressed via a half-silvered mirror and a storage vidicon that stores information for about 15 minutes. During this operation the crt uses electromagnetic deflection. Then the vidicon output is raster scanned onto the crt and photographed. This provides escort and target tracks. Then alphanumeric information is impressed on the crt and photographed.

An alphanumeric character generator made by RMS Associates develops escort and target identification for the main plot. Characters are made by leaving out strokes in the basic character-generating waveform a square-8 pattern. In the alphanumeric mode, the display crt is electrostatically deflected.

A Telemeter Magnetics ferrite-core memory stores radar range data and Datex Corp. four-track shaft encoders determine radar antenna position. L-band air-search and X-band navigation and surface-search radars aboard new RCN destroyer escorts are simulated.

How It Differs—Unlike the warfare simulator at the U. S. Naval War College in Newport, this simulator teaches team procedure rather than large-scale tactical operations. It differs from Royal Navy simulators in that control is digital rather than analog. It can simulate loss and recapture of sonar returns.

The trainer, excluding the government-furnished plotting tables and radar displays, cost about \$750,000. Operating cost is \$300 to \$400 an hour. Navy uses it some 35 hours a week and had only about 1½ days down time in the last three months. The trainer uses about 12,000 transistors.

So far, advances in asw work have required 23 modifications. One modification contemplated would permit display of coastlines and simulation of tides and currents. Other plans would build in more capability for simulating convoy operations and working with ships using the Navy Tactical Data System.

A second antisubmarine warfare simulator is reportedly under consideration by the RCN. It would presumably be installed at the Navy's Pacific base at Esquimalt, British Columbia.

New Numerical Control Aims at U. S. Market

HALIFAX, N. S.—Magnetic-drum data processing will permit the new UMAC 5 numerical control unit being made by Sperry Gyroscope of Canada Ltd., Montreal, to handle 32 different tools, each of different length, and to be programmed for

POLAROID CORPORATION USES CLAIREX[®]



...AGAIN!

- **FIRST FLASH EXPOSURE CONTROL USING PHOTOCONDUCTIVE CELL**

The world's most advanced camera, the Polaroid Land Automatic 100, contains a most advanced photoconductive cell by Clairex capable of high speed operation over a ratio of light levels greater than 10,000/1. This cell is a key component—a "light valve"—in the new camera's electronic shutter which permits perfect exposures in both color and black and white under all conditions, including flash operation. Precisely controlled characteristics, as well as speed and reliability, prompted Polaroid to rely on Clairex photoconductive cells for such an important task . . . a second time!

- **FIRST STILL CAMERA WITH PHOTOCONDUCTIVE CELL CONTROL**

Over four years ago, Polaroid Corporation came to Clairex and asked it to supply the critical photoconductive cell component for its "Microeye" exposure control device, a "first" for still cameras!

Have you considered the "light touch" . . . in your automation or control problem?

CLAIREX CORPORATION

The Finest in Photoconductive Cells . . . in and out of This World

New 16 page Photoconductive Cell Manual Free on Request

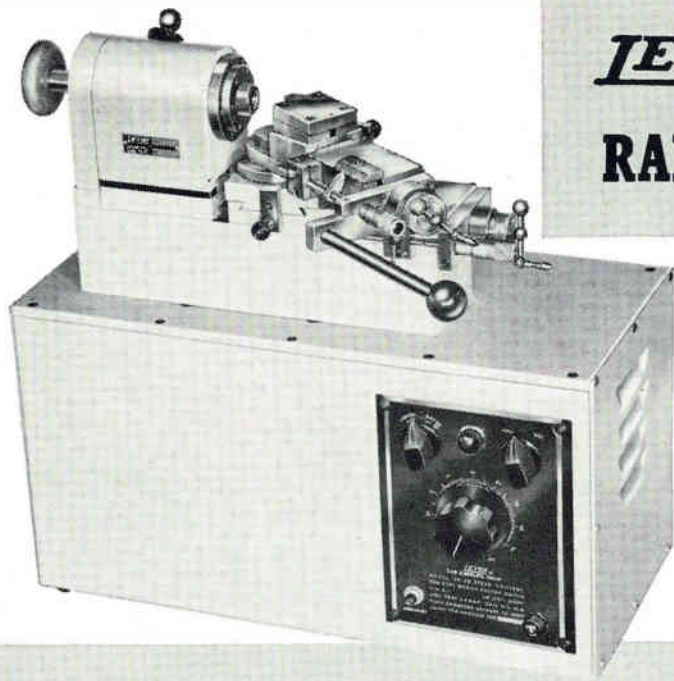

LEVIN PRECISION MICRO-RADIUS TURNING MACHINE



RADII FROM .000" UP TO ONE INCH - CONCAVE OR CONVEX

Here is a machine designed specifically for turning of accurate short radii in second operation work. This is not a lathe attachment, but rather a completely self-contained unit. It is available in $\frac{3}{16}$ ", $\frac{5}{16}$ ", and $\frac{1}{2}$ " collet capacities, with and without a production collet closer.

For full information and the name of your nearest authorized Levin representative, write

LEVIN®

LOUIS LEVIN & SON, INC.

3573 Hayden Ave.

Culver City, California

CIRCLE 201 ON READER SERVICE CARD

Origin

SILICON ZENER DIODE MODEL SZ-200

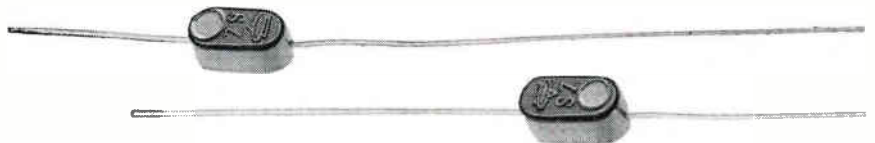

Silicon Zener Diode, Model SZ-200, is a 200mW class silicon Zener diode, manufactured by the diffusion method in the range of Zener voltage 7V-16V classes. After a special treatment, the diode is sealed in synthetic resin for stabilized characteristics to ensure long dependable performance.

Rating

Max. continuous permissible loss 200mW
 Max. ambient temperature 100°C
 Max. continuous permissible current

Characteristic (at 25°C)

Type	Zener Voltage (V)	Dynamic resistance	Saturable current	Nominal temperature	Zener Voltage	Current (mA)
SZ-200-7	6.2-8.0	15 (Ω)	1 μA 3.5 V	+0.04	7 V	28
SZ-200-9	7.5-10.0	10	1 6	+0.06	9 V	22
SZ-200-11	9.0-12.0	25	1 8	+0.07	11 V	18
SZ-200-13	11.0-14.5	60	0.5 10	+0.075	13 V	15
SZ-200-16	13.5-18.0	100	0.5 12	+0.08	16 V	12.5

Note: 1. The current used to measure Zener voltage and operating resistance is 5mA
 2. Maximum loss at 25°C is 200mW; reducing rate is -2mW/°C

SZ-200 Temperature Coefficiency

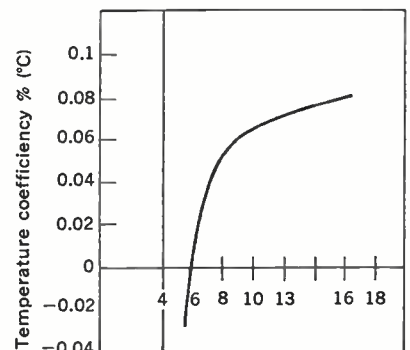

Main Products:

Semi-conductors, condenser type spot welder, synthetic enamel and miniature ball bearing.



ORIGIN ELECTRIC COMPANY LTD.

1-195 Takadaminami-cho, Toshima-ku, Tokyo, Japan.
 Cable Address: "ORIGINELE TOKYO"

use with different machines.

The control unit will use subminiature modules incorporating silicon transistors and afford a choice of linear, metal-case inductive transducers or rotary data elements. Use of special, servo hydraulic valves also enhance the unit's operations.

Although the first delivery will be made in January, the company reports a substantial backlog. Its primary use will be in metalworking although the control can be applied to wire-wrapping machines.

Laser Inspection—Sperry of Canada reported that it also is prime contractor on a \$420,000 developmental boring machine for the U. S. Air Force Systems Command. The numerically controlled machine will bore tiny holes in aerospace materials to an accuracy of 5 micro-inches.

A beam of laser light from the tool spindle will be reflected from the wall of the hole back to the spindle. If the distance measured by the laser differs from the desired dimension, automatic corrections can be made at the rate of up to 6,000 a minute.

Control Market—Sperry of Canada officials estimate the U. S. market for numerical control units at \$43 million in 1963, \$60 million in 1964 and \$120 million in 1967. In 1962, they say, some 1,000 units were installed at an average price of \$40,000.

The firm handles all the numerical control business of Sperry Rand. It got into the business some six years ago when it saw its military markets diminishing. Development of the UMAC 5 began a year ago.

Among advantages of doing business from Canada are listed the current lower value of the Canadian dollar (\$1.07 Canadian = \$1.00 U. S.), a somewhat lower wage scale and a certain amount of government support. Access to Commonwealth markets is facilitated and a relatively low U. S. tariff applies only to value added in Canada—not value of components, most of which are shipped in from the U. S.

The firm has made several sales in Western Europe and will supply computer programming in the metric system as well as voltage and frequency requirements to meet European standards.

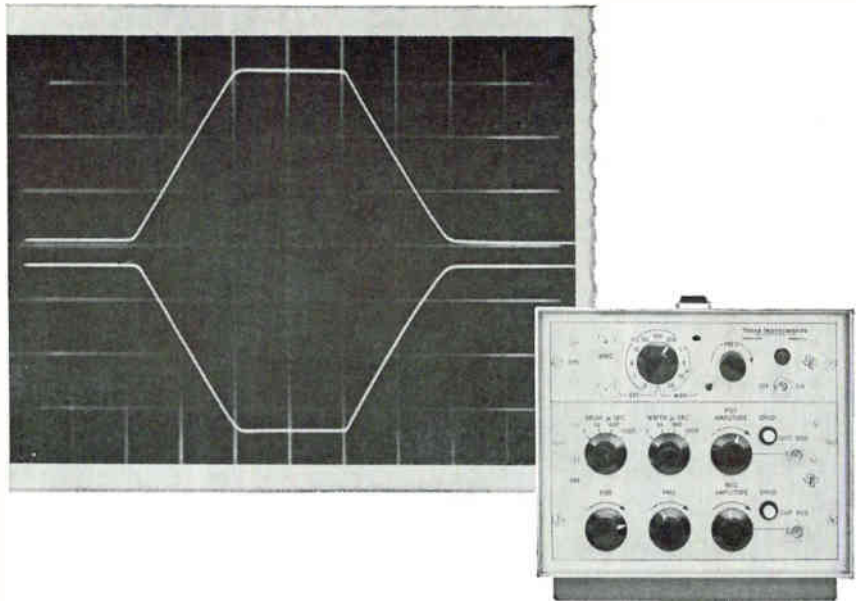

Clean waveforms with TI Model 7505 variable rise/fall time pulse unit

Clean waveforms are characteristic of TI pulse generators. The Model 7505 provides coincident positive and negative 10 volt pulses into 50 ohms with unlimited duty cycle . . . and both pulses can be simultaneously controlled in width, rise time, fall time and delay. Amplitudes are independently variable and outputs are short-proof, with overload indicators and reset buttons. Specifications, briefly . . . rise/fall times from less than 20 to 500 nanoseconds; width 40 nanoseconds to 1 millisecond; delay 90 nanoseconds to 1 millisecond; repetition rates to 25 megacycles. Like all Texas Instruments pulse generators, the Model 7505 is compact, lightweight and portable, extremely convenient to use. Circuitry is all solid-state.

Write for complete information.

INDUSTRIAL
PRODUCTS
GROUP

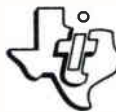

TEXAS INSTRUMENTS
INCORPORATED
P. O. BOX 66027 HOUSTON 6, TEXAS

SENSING . RECORDING . TESTING . DIGITIZING INSTRUMENTS
THE INSTRUMENTS OF TEXAS INSTRUMENTS

CIRCLE 43 ON READER SERVICE CARD ⁶⁰²

**WANT TO
DO BUSINESS
WITH THE
GOVERNMENT ????????**

Then check the Military and Government Procurement Guide in the orange section of your **ELECTRONICS BUYERS' GUIDE**.



IS NOW THE

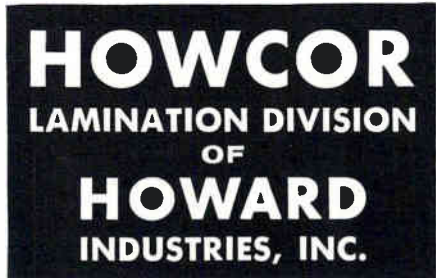

LOOK TO HOWCOR

for the quality you insist upon in your product components and the reliability you look for in your sources of supply.

LOOK TO HOWCOR

for additions to the Howcor standard line, expansion of the Howcor engineering staff, and for continued cooperation with steel mills in developing new lamination steels.

LOOK TO HOWCOR

for all the ingredients of thoroughly

* dependable lamination service:



GUARANTEED LAMINATION DIES



TOP-PERFORMANCE LAMINATIONS



ENGINEERING AND DESIGN ASSISTANCE



DELIVERY WHEN NEEDED



COMPETITIVE QUOTATIONS



Write for your copy of Bulletin 100, describing the facilities that go to work for you when you make Howcor your source of supply.



Thin-Film Memory Might Cost 0.3 Cent per Bit

Program aims at reducing cost of million-word memory two orders of magnitude

ATLANTIC CITY — Thin-film memory almost two orders of magnitude cheaper than present core memories of equivalent speed and capacity was proposed by J. I. Raffel, of MIT Lincoln Lab, at the 9th Annual Conference on Magnetism and Magnetic Materials last week. He outlined a program aimed at developing a memory of 1 million 36-bit words with cycle time in the range of 1 microsecond at a cost of about 0.3 cent per bit.

Basic structure under investigation consists of 24 1 × 24-inch glass strips side-by-side in a square plane. The strips are coated first with nickel-iron alloy and then copper; they would be etched into 2-mil lines on 4-mil centers. A similar plane is placed above with the strips perpendicular to the first set, and the copper coatings on the inside of the resulting sandwich are separated by SiO.

This array can be organized in a rectangular form with parallel access to 2,000 bits. A simple and cheap sense amplifier-digit driver circuit is being designed for this configuration that would, it is estimated, bring total cost to only 0.3 cent per bit. The amplifier would use positive feedback through a nonlinear element and consist basically of two diodes in a bridge arrangement.

Few machines can handle the increased information rate provided by having parallel access to 2,000 bits, Raffel said, adding that a system is presently being designed under a concurrent program at Lincoln Lab to take advantage of this capability.

Evaporated Memory—In another paper, T. J. Matcovich, W. Flannery, W. Luciw and A. A. Adomines, of Sperry Rand Univac, in Blue Bell, Pa., presented new data on the evaporated memory array reported at the 1963 INTERMAG

conference. They have now fabricated planar thin-film magnetic memory arrays of 64 × 24 elements (see photo) and 4 × 4 elements using evaporated matrix wiring and insulating layers.

Four metallic and three insulating layers are evaporated sequentially in a vacuum chamber. The longest lines are 1.35 inches long and 0.004 inch wide, film thickness is a few hundred angstroms. Unamplified output signals are typically 50 to

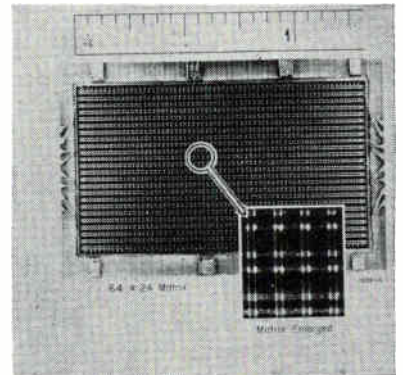

EVAPORATED memory array

100 microvolts, switching speed is 10 nsec. Authors therefore feel the device is potentially useful for a high-speed, low-power memory.

Film Switching — New switching technique for thin magnetic films was reported by J. H. Hoper, of Iowa State University. Magnetization of a thin film can be switched to either stable state and be detected nondestructively by applying orthogonal a-c fields instead of the usual pulse fields, Hoper said.

Technique is considered useful for large (10⁸ bits) memories. One reason is ease of fabrication—by having a common digit and sense line it may be possible to use a parametron both as a current driver for the longitudinal field and as a high-gain sense amplifier. With parametrons and a 2-Mc frequency, read and write times of 25 and 30 microseconds should be possible, he concluded.

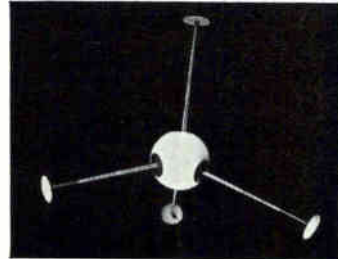
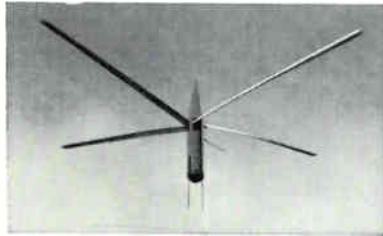

The value of diversity

The men at Space-General are deeply involved in every major area of space technology, from the development of electronic communication systems to complete space vehicles. ■ To the engineer or scientist of above average ability and ambition, this broad front of aerospace endeavor means a special kind of career opportunity. The chance to sink your teeth into a variety of challenging assignments...to gain the diversity of experience increasingly required of aerospace management. ■ *Among Current Projects:* Upper stages and research rocket systems for major space missions...re-entry paragliders for scientific experiments and space recovery... lunar payloads for observation and test... search systems to locate and identify downed objects...space telemetry ...ground communication systems for survival...bacteriological detection systems...advanced guidance and thrust vector control systems.

There are many outstanding career opportunities at Space-General for engineers and scientists with a B.S. degree or higher and at least two years of experience in any of the following fields:

Hydraulic-Pneumatic Controls Development • Structural Test Analysis • Space Vehicle Design • Guidance and Control Analysis • Heat Transfer-Thermodynamics Analysis • Stress Analysis • Trajectory Analysis and Aerodynamics • Advanced Sensor Research • Bio-Sensor Research • Microwave Research • Nuclear Test Instrumentation • Communication Systems Analysis • Circuit Design ■ Your resume will receive immediate confidential attention. *Send to:* Donald L. Craig, Employment Mgr., Space-General Corp., Dept. No. NP-14, 9200 E. Flair Drive, El Monte, California.

An equal opportunity employer.



SPACE-GENERAL CORPORATION

El Monte, California

A subsidiary of Aerojet-General Corporation

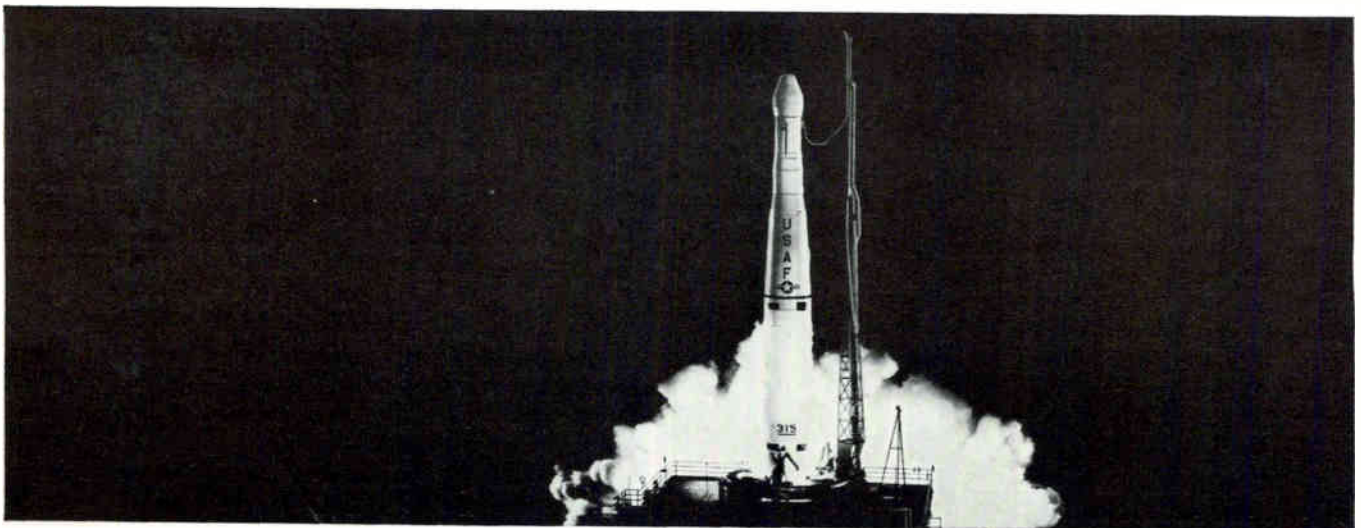

Optical Device To Contact Dolphins

Pattern recognizer
may translate between
man and sea animal

RESEARCHERS are attempting to communicate with dolphins, using for an intermediary a sophisticated optical speech-recognition device, the Sceptron. This novel communication problem was described and demonstrated at this week's 16th Annual Conference and exhibit on engineering in medicine and biology in Baltimore, by Leo. S. Balandis and George Rand of the Sperry Gyroscope Company in Great Neck, New York.

The Sperry scientists said that dolphins have long been known as extremely intelligent animals, with a language of their own. In studies by Dr. John Lilly at the Communications Research Institute it was found that dolphins freely communicate among themselves about food and underwater obstructions, and also have an ability to imitate human voices. Dr. Lilly believes that communication with dolphins, man's first contact with a non-human species, would have far-reaching evolutionary implications. Practically, dolphins could be used to perform various oceanographic measurements.

The Sceptron—Chosen for dolphin language research has been the SCEPTRON, short for Spectral Comparative Pattern Recognizer, a miniature device developed at Sperry Gyroscope for memorizing complex audio-frequency signals. It converts a signal into a unique light pattern, which directly corresponds to a frequency spectrum of the signal. The light pattern is photographed on a glass slide, which then becomes the memory. Signals with a different frequency content will

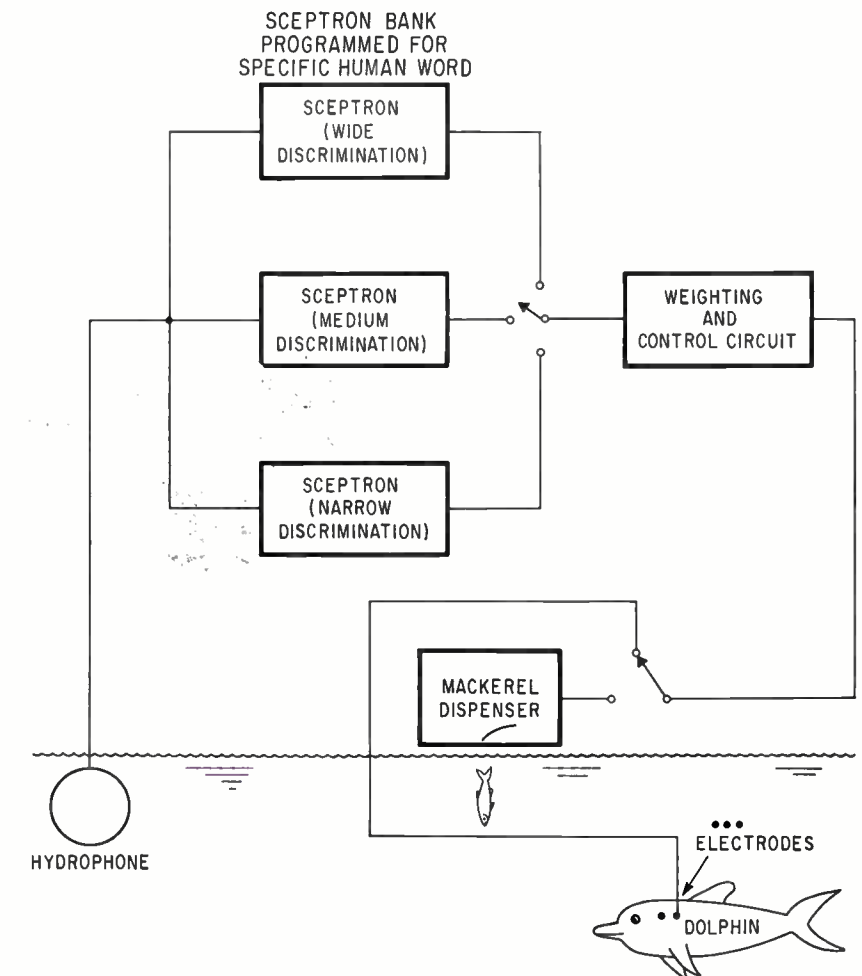

AUTOMATIC self-instruction device for training dolphins to pronounce human words will use wide discrimination for initial training; other two Sceptrons are narrower to follow improvement in dolphin's selectivity. Mackerel is released when correct word is pronounced. Alternatively, electrodes in dolphin's brain induce specific pleasure sensation as reward

not match this memory mask. Photocells are used for simple and continuous comparison between signals and the Sceptron memory (see *ELECTRONICS*, p 28, Oct. 26, 1962).

The sound frequency spectrum is converted into a light pattern by an array of quartz fibers that transmit light. The fibers are graded in length so that each has a different natural vibration frequency; they are held at one end and free to move at the other.

When mounted on an electromechanical transducer and driven by

a sound signal, the fibers vibrate in a pattern characteristic of that signal only. Since each fiber carries a beam of light, the vibrations appear as a light pattern emerging from the fiber ends.

Sceptron and Dolphins — Signals were recorded at the Woods Hole Oceanographic Institution from a group of a selected dolphin species with particularly strong signals. The signals typically start at 10 kc, sweep down to 5 kc and back to 10 kc, all in 0.1 second. This pat-

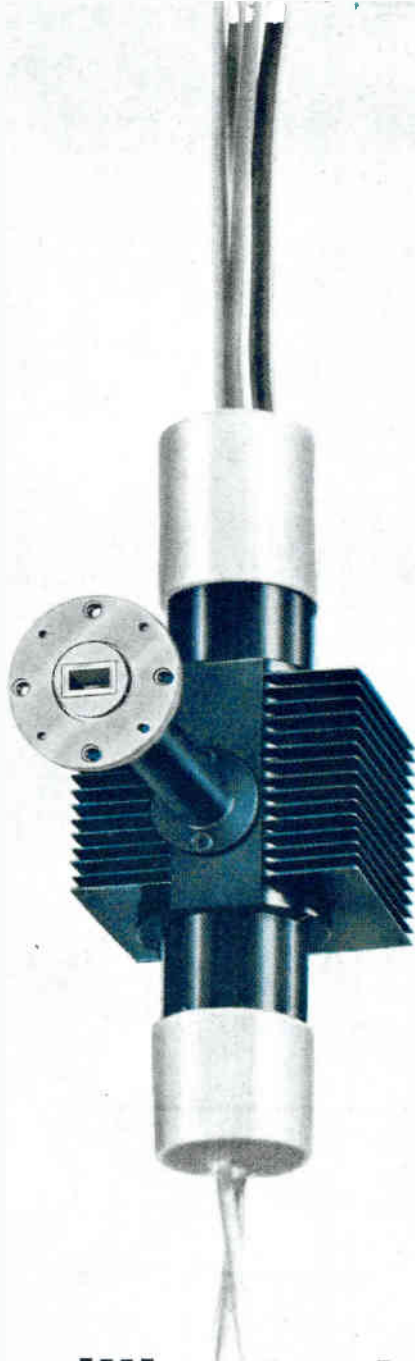

*New ITT
35 Gc Klystron*

ITT 8 millimeter klystron puts out 1.5 watts!

This new millimeter wavelength reflex klystron by ITT delivers a whopping 1.5 watts—more than twice as much power as any reflex klystron we know of in the 32-38 Gc range. The F-2900 is the first of a new ITT line of millimeter klystrons. Three types are now available from stock and can be supplied with mechanical tuners. Bench-type power supplies designed for use with these tubes are also in stock. Write for additional data and tell us about your millimeter wave application.



ELECTRON TUBE DIVISION

CLIFTON, NEW JERSEY

INTERNATIONAL TELEPHONE AND TELEGRAPH CORPORATION

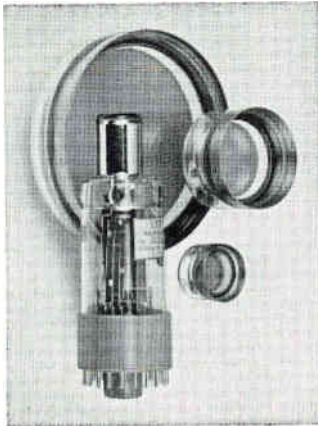

To: ITT INDUSTRIAL LABORATORIES
 Dept. 61200
 3700 East Pontiac Street
 Fort Wayne, Indiana

Please send me additional information on
 multiplier phototubes, biplanar photodiodes. The application I have in mind is:

NAME _____

TITLE _____

COMPANY _____

ADDRESS _____

CITY _____ ZONE _____ STATE _____



SPERRY engineer holds microphone for dolphin. Normally, hydrophone is used

**This coupon
 will bring you data on
 LASER DETECTORS
 with single photoelectron sensitivity**

Deflectable multiplier phototubes with single photoelectron sensitivity; diode phototubes with half nanosecond response and current-carrying capacities linear from one-billionth amp to 50 amps.

Characteristics like these—so vital in laser research—are available today in the new ITT line of multiplier phototubes and biplanar photodiodes. These devices, covering the entire spectrum from infrared to far ultraviolet, have pulse-counting characteristics and signal-to-noise ratios superior to any other tube or device now available.

ITT photomultipliers have a response range from dc to approximately 100 Mc, a sensitivity extending down to 10^{-17} watts, a capability of detecting single photoelectrons, and magnetic deflection for alignment and tracking purposes.

ITT biplanar photodiodes cover a tremendous dynamic range of currents from 10^{-9} amps to 50 amps. Their extremely short transit time of less than $\frac{1}{2}$ nanosecond makes possible very high frequency response.

If you are working on the fundamental properties of laser radiation or investigating new laser applications, look into ITT's new line of photo detectors. Send in above for complete specifications. ITT Industrial Laboratories, a division of International Telephone and Telegraph Corporation, Dept. 61200, 3700 East Pontiac St., Fort Wayne, Ind.

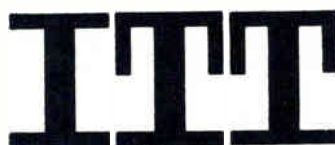

tern is rapidly repeated several times. To make the sounds more meaningful to human ears, the dolphin sounds were slowed down to $\frac{1}{4}$ of their original speed.

The programming consisted of playing the recorded signal through a Sceptron during a three-second light exposure. Out of 350 fibers in the Sceptron, about 70 responded.

The next proposed step, said the Sperry scientists, would be for men to try to imitate the recorded dolphin words, using the Sceptron record as a criterion. Human imitations could then be played back to the dolphins.

Experiments may also be conducted in training the dolphin to pronounce certain human words. For this, researchers visualize a Sceptron connected to a training device—dispensing mackerels—to induce the dolphins to imitate the word. Dr. Lilly has also suggested inserting electrodes into the motivational portions of the dolphin's brain to create specific pleasure sensations when the dolphin correctly imitates the human words.

The next phase would be the compilation of a dictionary of dolphin language, correlating the recorded sounds with different kinds of activity. The Sceptron can perform the function of a translator by selecting the proper catalog pulse when a human word is spoken. The final phase, of course, is two-way communication between man and dolphin.

Present research into dolphin sounds is sponsored by the Navy.

TV Helps Astronomers Put Stratoscope II On Target

BOSTON—When Stratoscope II, the balloon-borne astronomical telescope, is flown next month from Palestine, Texas, a special tv system will permit the astronomer on the ground to see through the telescope so he can aim the camera telescope accurately by radio command.

Information supplied by the on-board tv will permit intelligent control of the telescope aiming servo system (ELECTRONICS, p 47, Feb. 8, 1963 and p 30, Sept. 21, 1962). Both tv and servo are part of a complex command system permitting control from the ground, rather than control by a programmed computer aboard, pointed out W. S. Pike of RCA Laboratories at the 94th technical conference of the Society of Motion Picture and Television Engineers.

The Stratoscope II television system will be using a new frequency on this flight: a newly assigned 25-Mc channel centered on 1,522.5 Mc, replacing the previously used 6 Mc channel at 563 Mc, which was too narrow a band for frequency modulation. F-m will be used exclusively in the new equipment. The transmitter is again a master oscillator-power amplifier circuit, the oscillator being directly frequency controlled by a varactor diode. Pike told the SMPTE conference. The transmitter will be duplicated for reliability.

The change from a-m to f-m means omitting the high-power modulator previously used, and permits the two new transmitters to be placed in the housing of the old single unit. Power output is about 20 watts.

The new receiver uses an 8-ft. parabolic antenna mounted on its own truck. A parametric amplifier on the back of the dish enables an overall receiver noise figure of about 2 db to be achieved, Pike said.

Like the first flight of the balloon last March, next month's launch will start with an infrared observation, the photographic camera on the telescope being replaced by an infrared spectrograph using germanium bolometers operated at liquid helium temperatures. The special bolometers used were fabricated by Texas Instruments.

**Mort
Mann
can
show
you...**



Sales Engineer, North Atlantic Industries

how North Atlantic's Phase Angle Voltmeters* solve tough ac measurement problems ... in the lab or in the field.

Designed for critical tasks in circuit development, production and testing, North Atlantic's Phase Angle Voltmeters provide direct reading of phase angle, nulls, total, quadrature and in-phase voltages—with proven dependability even under field conditions. Your North Atlantic engineering representative can quickly demonstrate how they simplify ac measurement jobs from missile checkout to alignment of analog computers—from phasing servo motors to zeroing precision synchros and transducers.

Shown below are condensed specifications for single-frequency Model VM-202. Other models include high sensitivity, three-frequency and broadband types.

Voltage Range.....	1 mv to 300 v f.s., 12 ranges
Voltage Accuracy.....	±2% f.s.
Phase Accuracy.....	dial: ±1°; meter: ±3% of F.S. degrees
Signal Frequency.....	1 Freq., 30 cps—10 kc
Input Impedance.....	10 megohms
Reference Input.....	100 K, 0.25 v min.
Meter scale.....	3-0-3, 10-0-10 linear
Phase Angle Dial.....	4 scales, 90° (elec.) apart
Nulling Sensitivity.....	2 microvolts (phase sensitive)
Harmonic Rejection.....	55db (with filters)
Dimensions.....	5¼" h. x 19" w. x 7½" d.

The North Atlantic man in your area has full data on standard and special models for laboratory, production and ground support. Call today for his name, or request Bulletin VM-202.

**Trademark*



NORTH ATLANTIC industries, inc.
TERMINAL DRIVE, PLAINVIEW, L. I., NEW YORK • Overbrook 1-8600



She's giving back the ring

Easily replaced circuits—great advantage of ITT Kellogg's new Electronic Telephone Exchanges—made possible by THIOKOL PANELYTE Copper-Clad laminated sheets

ITT Kellogg's new Electronic Telephone Exchange Systems represent one of the great advances in modern telephony. If a malfunction occurs in any one of the circuits, an office secretary can handle the necessary maintenance. All that's required is the manual removal of the faulty circuit board and quick plug-in replacement with a handy spare.

ITT Kellogg selected Thiokol Panelyte Copper-Clad circuit board for this unique and vital application. Reason: Panelyte Copper-Clad combines the high electrical and physical properties required. The glass epoxy G-10 Thiokol Panelyte Grade 1635 flame retardant chosen provides both the insulation strength and solder resistance specified by ITT Kellogg. This Panelyte grade is one of 10 special copper combinations engineered for special requirements.

Panelyte Copper-Clad and other electrical grades meet NEMA and government specifications. For full information write to Panelyte. Or see Sweet's Catalog.



Laminated Sheet, Rod, Tube, High Pressure Moldings, Elastomeric Compounds and thin copper-clad laminates for multi-circuit application.
Thiokol Chemical Corp., Panelyte Industrial Div., N. Enterprise Ave., Trenton 4, N.J.

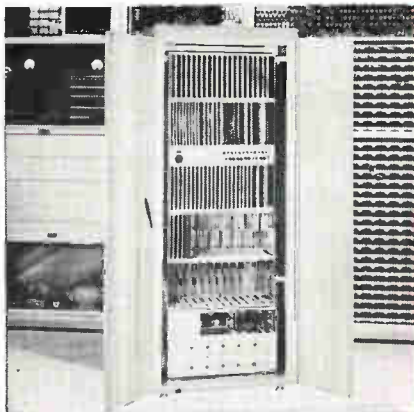

Through use of transistors, other electronic inventions, and Thiokol Panelyte Copper-Clad printed circuit boards, ITT Kellogg has reduced to file cabinet size and to 425 pounds the private automatic telephone exchange. Shown here: KELEX compared to conventional electro mechanical system.

To the right is the ITT Kellogg printed circuit board made from Thiokol Panelyte Copper-Clad Sheet in comparison to the electro mechanical equipment which it replaces.

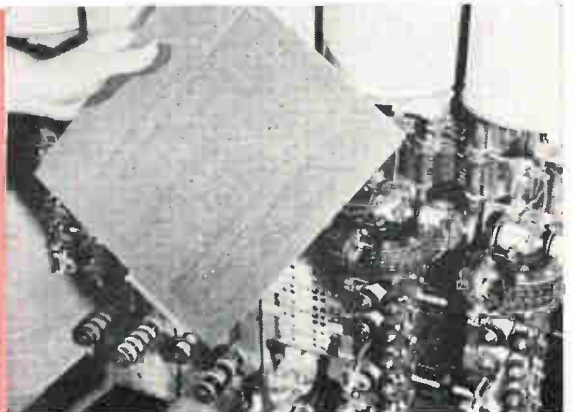

Ceramic Substrate Improves Microcircuit Reliability

Surface accepts thin-film depositions directly, reduces interconnections

INTERCONNECTIONS to microcircuits have posed problems that are now gradually being overcome and are leading to wider and more rapid acceptance for practical equipment.

Improvements include interconnections of functional elements within the circuit itself, and the outer leads to power and controls.

Amphenol-Borg exploits a precision moldable ceramic which they plan to incorporate into their overall packaging program (ELECTRONICS, April 5, p 52). Circuits deposited on their new substrates promise to reduce military and commercial computer size as much as 20 times, while also improving reliability, company says. The technique is still in development stage, will be available early next year.

Advantages—The bottom substrate (see cover) illustrates a first step in development, and shows the vitrified ceramic substrate after fire shrinking. The ceramic is formed from a compound of aluminum oxide. The 2 x 2-in. molded substrate shown holds one-thousandth of an inch tolerance over its full area. Additional processing is not necessary. The vitrified surface accepts thin-film depositions comparable to those now laid down on glass, reports Vic Elarde, director of materials and companies research.

Reliability is augmented by channels on one side of the substrate. Peripheral junctions to the vapor-deposited thin films are eliminated

(center substrate on cover).

Thin film elements can be deposited directly into the bottom of the terminal channels (traced in the top substrate on the cover) as part of the same process which deposits the thin film on the substrate. This does away with additional deposition of terminal pads as well as additional interconnections between the substrates and the outside connectors. Vapor deposition of gold or nickel into the bottom of the terminal channels as part of the same cycle as the thin-film circuit deposition results in a highly reliable conducting interface for outside leads.

Thickness of vitrified substrates range between 0.025 and 0.04 inch, with 0.03 the most popular dimension. Maximum size reductions possible from using these interconnectors will depend on the customer's choice of discrete components or semiconductor chips to be integrated with the thin film circuitry.

Forced-air cooling past recessed areas of the stacked substrates (photo) will make denser packing of active elements possible.

Low temperature (300-400F) solder has proven more satisfactory for connecting active elements to thin-film circuits than conductive epoxies, Elarde says. Current experiments are aimed at developing more advanced deposition materials and refining deposition techniques of active elements.

The company intends to deposit thin-film circuits on the new substrates to suit a wide range of customer requirements. Les Roby, manager, systems packaging, is already considering multiple-layered mother boards and other substrate forms for wireless missile guidance

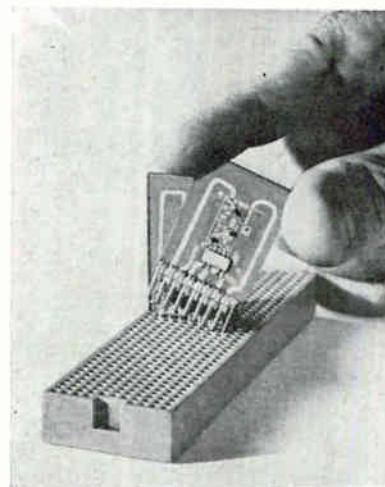

VERTICAL stacking of ceramic substrates allows forced air cooling. Active elements can be densely packed in recesses between raised grooved ends of modules

systems and computers with all interconnections plated except the power cord.

Hall-Effect Devices May Find Wide Use

INTEREST IN practical applications of Hall generators is being renewed today—84 years after discovery of the Hall effect. Hall generators were first applied in the early 1950's but feeling is strong in Europe that the devices are now ready for widespread use. For this reason, a special session on Hall effect was held at the IEEE Electron Devices Meeting, in Washington Oct. 29-Nov. 1.

In an invited survey paper, Herbert Weiss, of Siemens-Schuckertwerke in Erlangen, claimed the devices are now mature for practical applications, but their usefulness depends on knowing how to design the associated magnetic circuits as well

NOW!!
a bright new
name in space



COLLEGE HILL
INDUSTRIES, INC.

formerly
Speidel CORPORATION
INDUSTRIAL DIVISION

**Manufacturers of...
Recorder-Reproducers
& Pressure Switches**

CHI has taken over completely, the former Speidel Industrial Division... plant, equipment, personnel and products. This means the same people will continue to make the famous Inertia Compensated Recorder-Reproducers and Pressure Switches you have known as Speidel. On this foundation, we are building CHI, a new and growing company with new products to be announced soon.

So watch for this name — College Hill Industries, Inc. — it will play a star role in outer space achievements.

WARWICK
INDUSTRIAL
DRIVE,
WARWICK
RHODE
ISLAND



College Hill Industries, Inc.

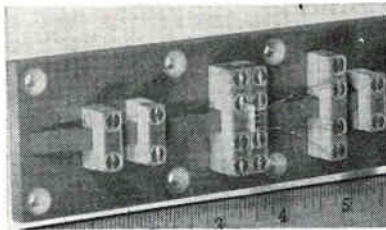

MAGNETOMETER produces 1 volt per gauss for control current of 350 ma when operated at 78 deg K (Ohio Semiconductors)

as the device itself.

Weiss described an impressive selection of actual industrial-control applications, most based on the ability of a Hall generator to measure position of a nearby moving magnet. These applications include positioning contactors in elevators, counting shaft rotations, controlling conveyor belts and controlling read-write head positions in magnetic tape systems. Some examples of what else can be done with Hall effect were given by other speakers:

Magnetometers—N. P. Milligan and J. P. Burgess, of Ohio Semiconductors, described low-level magnetic detection devices that combine optimized Hall plates and magnetic flux concentrators. The devices can sense the polarity and magnitude of low-level magnetic variations from d-c to several megacycles without complex associated electronics.

Indium antimonide near 78 deg K gives a stable, high-output sensor capable of detecting magnetic levels as low as 1 gamma over a wide bandwidth of magnetic field frequency changes, the authors said. A concentrator and InSb probe assembly that is in actual use is shown in the photo. This magnetometer produces a stable output voltage and has a sensitivity of more than 3,000 volts per ampere kilogauss. Hall magnetometers weighing only 0.004 gram yet producing one volt per gauss output are considered feasible.

Isotunnel Amplifiers — Unidirectional tunnel-diode amplifiers using Hall isolators were reported to be feasible by Herbert Kroemer, of Varian Associates. Compared to ferrite isolators they would be simpler and capable of d-c operation; the isolation loss of 7 to 8 db is not considered large enough to

make them impractical. A scheme that would give optimum frequency response, and impedance characteristics like a vacuum triode is illustrated.

Vector-Product Generators — An unconventional Hall-effect multiplier—one that accepts vectorial input signals and produces an output signal in the direction of, and proportional to, the vector product of the input vectors—was described in a paper by W. Saraga and R. K. P. Galpin, of A. E. I. Ltd. The device can generate sum and difference frequencies, and is considered potentially useful for communications problems such as modulation.

Ternary Logic—Another application of Hall effect lies in ternary logic. C. F. Kooi and J. L. Weaver, of Lockheed Research Labs, discussed applying the non-linear saturable Hall effect to a ternary logic element. This is an element with two input channels and one output, where each channel can have only one of three distinct signals on it at a given time and the signal on the output channel is completely determined by the signals on the input channels at that time. Present units switch at 100 μ sec, but reduction in size is expected to reduce this to below 1 μ sec.

Magnetoresistance — Analog computing elements, amplifiers, oscillators, mixers, modulators and demodulators were among potential applications of this related effect cited by S. F. Sun, of Technische Hochschule Stuttgart. He described a push-pull arrangement of two magnetoresistance elements that results in a three-dimensional electronic multiplier whose input current represent three parameters and

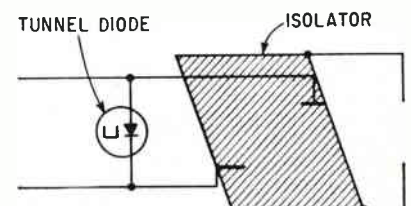

ISOTUNNEL AMPLIFIER would use parallelogram-shaped Hall isolator (Varian Associates)

whose output voltage gives their product. The magnetoresistance elements can consist of indium antimonide films deposited on the pole face of small magnetic cores that have two windings where the magnetic fields are applied. These room temperature devices could give higher sensitivity and better efficiency than Hall-effect devices in a variety of applications, according to Sun.

Half-Inch Ceramic Tube Delivers 40 Watts

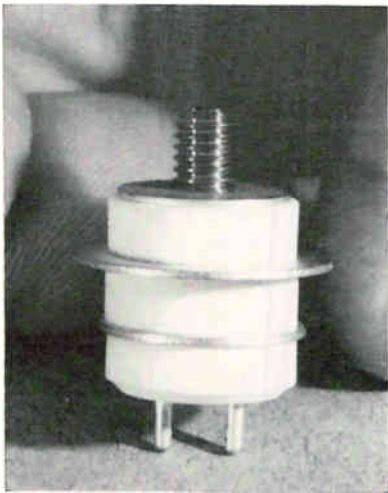

GETTING 40 watts of output at 400 megacycles is significant advance for this power-size-frequency combination. Potential applications include telemetry and land, sea, air and space communications.

Developmental General Electric tube has been housed in a 2 x 7 x 9-inch aluminum chassis made into an r-f amplifier. The triode had an efficiency of 76 percent. Unit is called a planar coaxial amplifier. Flat surfaces of the chassis constitute the outer conductor of the coaxial circuit. Driven with 6 watts of power, the amplifier has shown a power gain of 6.5 to 1 without apparent strain on the tube.

The 40-watt output was obtained by supplying an input of approximately 500 volts and 100 milliamperes to the plate circuit. Actually, the tube was driven to deliver 58 watts output at 400 megacycles before the quarter-wave copper rod forming the anode line plate tubing turned blue with heat and output began to drop off.

TO SEE WHAT AIR CAN DO SEE GARDNER-DENVER

In the sixties alone we have added hundreds of new and improved products to our lines of compressors, rock drills, air tools, drilling rigs. So before you invest in new air equipment, find out—from Gardner-Denver—how air can serve you better.

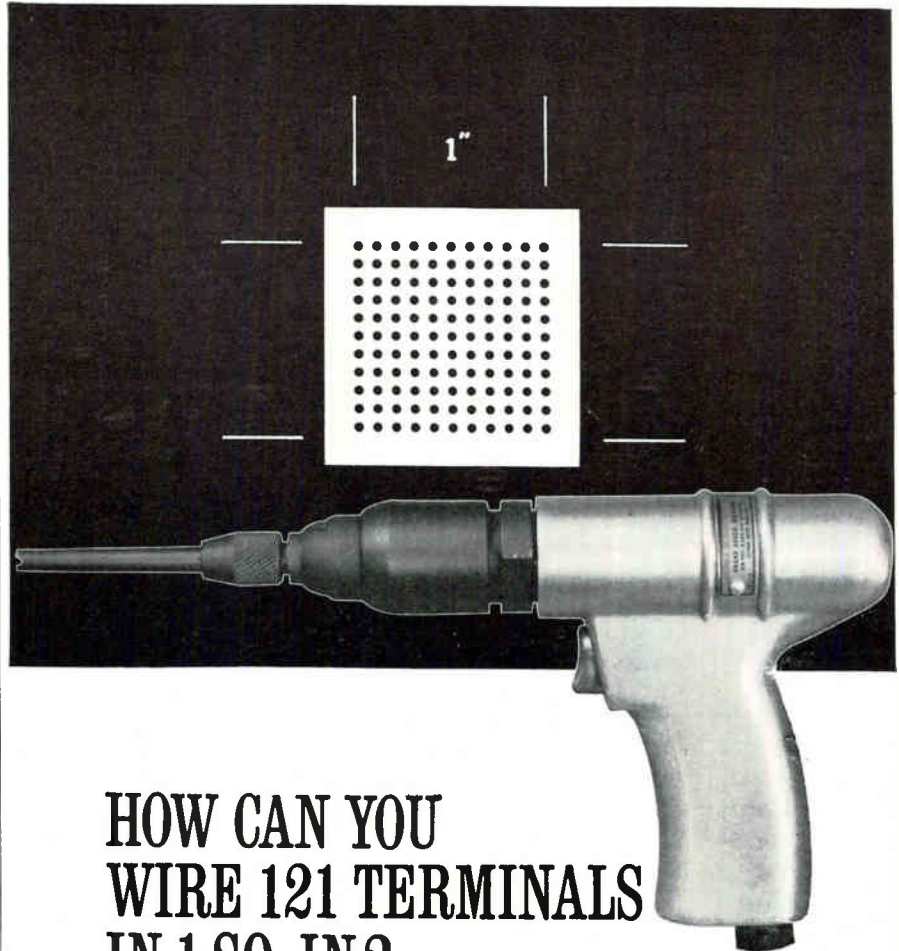

HOW CAN YOU WIRE 121 TERMINALS IN 1 SQ. IN.?

It is possible—and practical. Using 30- or 32-gauge wire, Gardner-Denver "Wire-Wrap"® tools make connections on 1/10" grid spacings. Newly designed miniaturized bits and sleeves make it possible. These attachments fit on present battery-powered or other "Wire-Wrap" tools.

High density packaging requires closely spaced terminals to meet industry's demands for smaller components in miniaturized equipment.

Connections made with "Wire-Wrap" tools are permanent. Proof: 15 billion solderless wrapped connections without a reported electrical failure.

For details on "Wire-Wrap" tools, write for Bulletin 14-1.



KEEP UP-TO-DATE WITH
GARDNER - DENVER

Gardner-Denver Company, Quincy, Illinois

Multi-Frequency Transducers Improve Ultrasonic Cleaning

Prevents standing waves; workpieces of many shapes cleaned in one operation

ULTRASONIC CLEANING for production purposes is improved by a new transducer design, reports Crest Ultrasonic Corp., of Trenton, N. J. The transducer is shock excited by pulses to produce many frequencies covering a broad ultrasonic spectrum in the cleaning-tank solution, according to E. G. Cook, president of Crest. Conventional transducers operate at a single frequency.

Single-operation cleaning, uniform distribution of cleaning action and simultaneous cleaning of workpieces with many different shapes are leading advantages of this transducer, Cook says. Field and experimental data show that higher frequencies clean small cracks, capillaries and orifices while lower frequencies purge large surfaces and broad areas, he adds. Basic principles of the cleaning action is that higher frequencies penetrate under and loosen contaminants so that the lower frequencies efficiently wipe them away.

This technique eliminates stand-

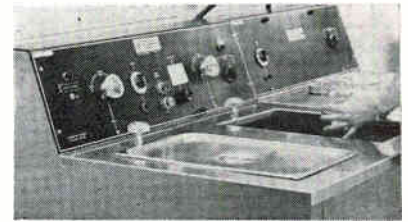
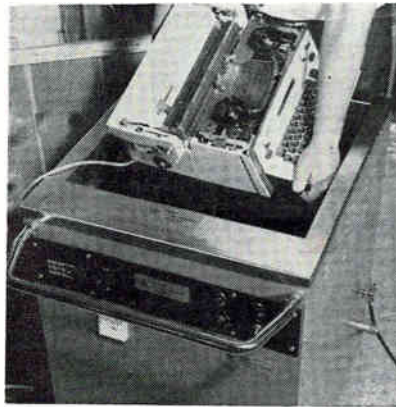

BOTH LARGE AND SMALL workpieces can be cleaned by multi-frequency systems. At right, small parts are handled in beaker

ing waves in the cleaning tank. A single-frequency wave produced in a tank will reflect from sides and bottom to produce a standing-wave pattern. The affect of this, Cook says, is nonuniform cleaning action within the tank because energy varies in proportion to the peaks and nulls of the waves. The use of many frequencies creates a general disturbance in the tank, distributing cleaning action equally in all areas.

Transducer Design—Made of a new high-temperature titanate, the transducers can operate continuously at temperatures up to 212 F. This special material, according to Cook, combines the mechanical strength of magnetostrictive devices with the high-efficiency of barium-titanate types.

The transducer operates on a variety of fundamental frequencies due to its rectangular form. Like a rectangular drumhead struck in its center, and randomly excited by a pulse-like waveform, vibrations in more than one resonant frequency are governed by its length, width, and diagonals. Thus the transducer vibrates at various resonant frequencies, plus their harmonics.

Matching is not critical because each transducer vibrates independently, reducing maintenance difficulties and costs. Although designed to radiate in an area of 15 square inches, thick metal baffle plates and bonding of transducers to tank sides or bottom allow any number of transducers to be used in the tank. This allows tanks to be made in any size.

Application—One use of multifrequency ultrasonic cleaning is production cleaning of finished semiconductor components mounted on printed circuit boards. Simultaneous use of many frequencies at individually lower power levels prevents sympathetic vibration of the internal leads and dampens isolated resonance. Its high-efficiency reduces time required to clean, thus minimizing exposure of the delicate devices to ultrasonic cleaning forces, Cook says.

Multifrequency ultrasonic cleaning is particularly suited to semiconductor device cleaning, he adds, because it has the ability to penetrate small capillary openings on the semiconductor body and remove oxide residues. This oxide, formed

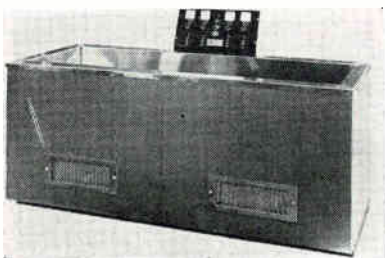

120-GALLON tank uses several transducers with steel baffle plates

LOW C...

(-55°C)

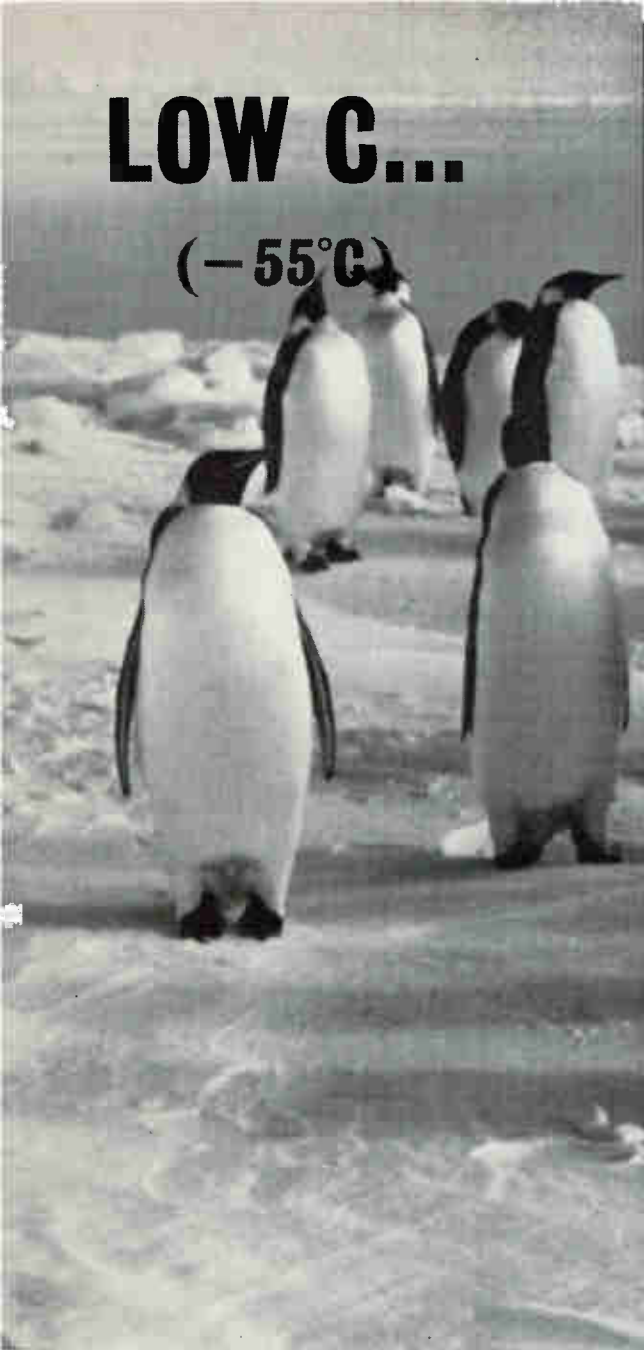

...HIGH C

(+125°C)

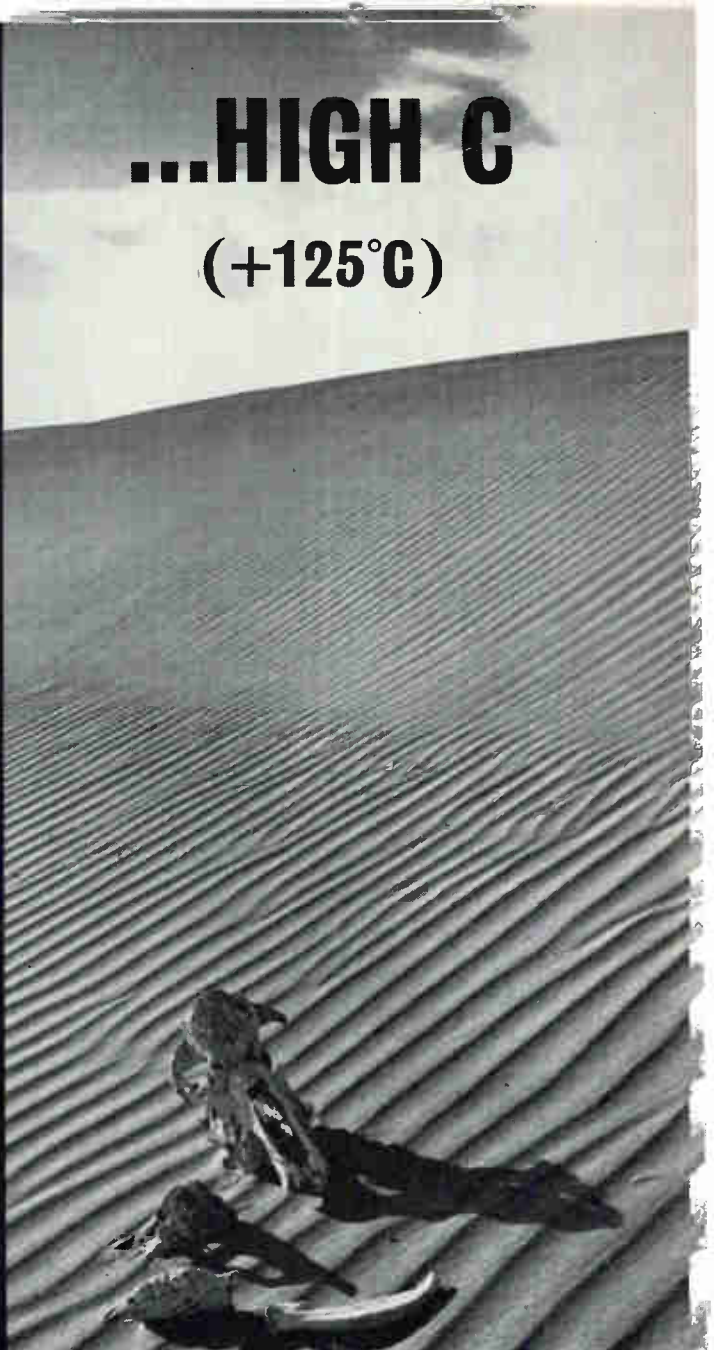

thermal breakthrough in aluminum electrolytics

TYPICAL PERFORMANCE DATA—TYPE HTA

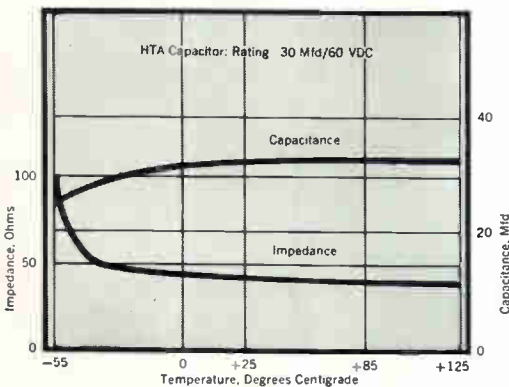

Typical stability of capacitance at low and high temperatures.

Compared to ordinary aluminum capacitors normally rated -30°C to $+85^{\circ}\text{C}$, new Mallory Type HTA capacitors can work over a far greater ambient range, from -55°C to $+125^{\circ}\text{C}$. At the top end . . . plenty of life and reliability. At the low end . . . plenty of capacitance stability.

The Mallory HTA is a new kind of aluminum electrolytic capacitor. For the first time, designers of industrial and commercial electronic circuits can apply the economy of aluminum capacitors to applications in high and low temperature ranges—and still have performance characteristics approaching those of tantalum units.

Take a close look at the HTA's temperature performance: you may find a lot of spots where you figure nothing but tantalum would do. HTA's are supplied in ratings of 8 to 300 mfd, 60 to 3 volts. Standard diameter is $\frac{3}{8}$ -inch. Case length is $\frac{1}{16}$ to $1\frac{5}{8}$ inches. Tubular aluminum case, with axial leads. Supplied with Mylar* sleeve if desired.

Call or write today for technical data. Mallory Capacitor Company, Indianapolis 6, Indiana—a division of P. R. Mallory & Co. Inc.

*Du Pont trademark



CIRCLE 55 ON READER SERVICE CARD

20 to 200 D.P.

Send your prints
for quotations

- SPURS
- HELICALS
- WORM AND WORM GEARS
- STRAIGHT BEVELS
- LEAD SCREWS
- RATCHETS
- CLUSTER GEARS
- RACKS
- INTERNALS
- ODD SHAPES

A few of the many varieties of straight bevels we are regularly producing are shown above. Tell us your needs.

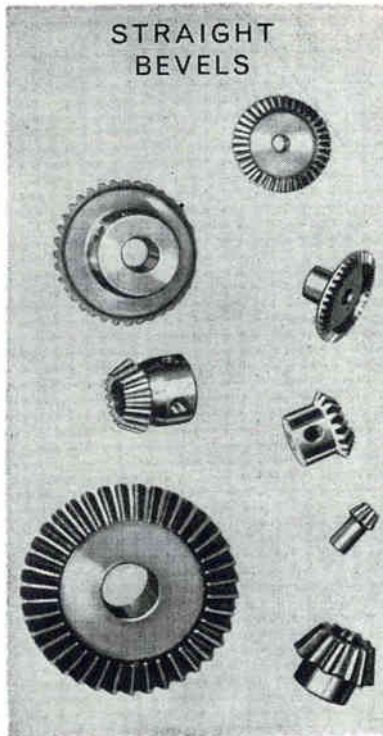

THE *Finest* IN GEARS

Beaver Gear Works Inc.

1021 PARMELE STREET, ROCKFORD, ILLINOIS



CIRCLE 202 ON READER SERVICE CARD

WHAT'S UNIQUE
ABOUT ALL
SEVEN MODELS
OF FLUKE
DIFFERENTIAL
VOLTMETERS

ALL SEVEN
MODELS FEATURE
INFINITE INPUT
RESISTANCE
AT NULL

For CATALOG DIGEST: Write
JOHN FLUKE MFG. CO., INC.,
Box 7428, Seattle, Wash. 98133

FLUKE

WORLD'S FASTEST SWITCHING DIODES WITH HIGH FORWARD CONDUCTANCE

With All these features:

Reverse Recovery Time in Nanosecond and picosecond ranges with forward conductance of 100 ma to 500 ma @ +1V.

Our devices include such industry-tested diodes as: Q6-100, Q5-100, Q3-90, Q7-250, ID5-050, ID3-050, ID1-050, ID10-050, ID6-050, 1N3146 etc. For more information see *electronics* October 18, 1963 issue, pages 42-45 and *REVIEW OF SCIENTIFIC INSTRUMENTS* April 1962, pages 423-428 and April 1963, pages 412-413.

For T Series diodes (add "T" to the above numbers) Minimum $I_r = 200$ ma. @ + 1V.

Prices from \$1.25 up. Delivery: from stock.

Super-fast switching transistors in the development stage.

**INTERNATIONAL DIODE
CORPORATION**

90 Forrest Street
Jersey City 4, New Jersey
Tel: 201-432-7151

CIRCLE 203 ON READER SERVICE CARD

by high-temperature sealing operations is a major cause of premature field failures in semiconductors, says Cook.

Welding Joins Aluminum To Other Metals Easily

ALCOA Research Labs reports a new method for joining aluminum to copper, titanium and galvanized or aluminized steel sheet, with less time and cost. The method makes it easier to combine aluminum with other metals, where corrosion protection or other advantages of aluminum are desired.

Called Alcoa R305 process it uses standard gas metal-arc welding equipment—and requires virtually no pre-or-post-weld processing. Completed welds resemble riveted joints but display better electrical conductivity than mechanically fastened joints. Ductility and corrosion resistance are good, and joint strength is similar to that of all-aluminum gas metal-arc spot welds says Alcoa.

This Process using a lap joint design with the aluminum on the bottom requires the nozzle of the electrode holder to be placed against the metal to be joined. Aluminum filler metal pushes through the softening top layer and bonds to the aluminum base during energizing of the welding arc. Filler metal hardens and forms a fused rivet of ductile aluminum with the head joined to the top surface and foot welded to the bottom member of the lap joint. If the other metal is more than 0.03 inch, a 1/4 inch pilot hole must be drilled through it to provide a path for the filler metal.

Generally, the filler and bottom member must be of the same metal but the other metals may be used on the bottom if suitable fillers are available of the same metal. Also higher melting points may be desired. Improvement of joint strength is possible by sandwiching the aluminum between layers of other material.

The Alcoa process can be used to join two or more pieces of aluminized steel by the use of an aluminum backing strip placed under

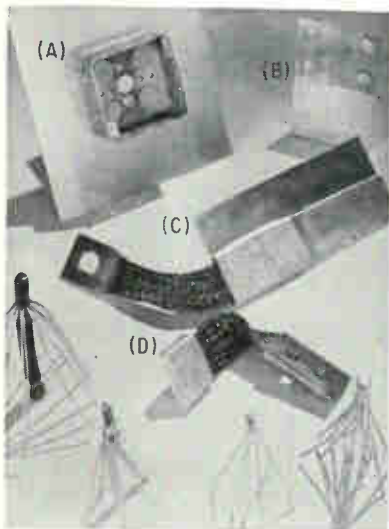

ALUMINUM is welded to steel (A), copper plate (B), and flexible copper cable (C). Also shown are cross-section welded joint (D), and welded joints of solid aluminum wires to various other conductors

the bottom steel layer. The resulting joint exposes only aluminum surfaces to corrosive atmospheres to insure good performance.

Multiple layers of material are easily joined but the pilot holes must be drilled when total thickness of the layers to be penetrated by the filler metal exceeds 0.03 inch.

Inert-Atmosphere Welder

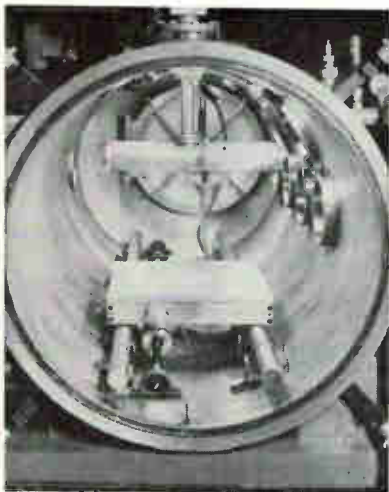

LARGE WORKPIECES can be welded in an inert atmosphere in this chamber developed by Vacuum Specialties, Somerville, Mass. Equipment includes mechanized carriage and torch control

your diffusion furnaces are obsolete

unless they have these five features:

- 1 1400° C continuous operating temp
- 2 24-inch thermal flat zones
- 3 $\pm 1/2^\circ\text{C}$
- 4 Ultra-fast recovery time
- 5 Only one control instrument



All these features plus everything you expect in a diffusion furnace are incorporated in two new Hayes Diffusion Furnaces . . . Models DK and DC. Write today for data sheets on Hayes' Model DK and DC Diffusion Furnaces. C. I. Hayes, Inc., 845 Wellington Avenue, Cranston 10, Rhode Island. (Phone 401-461-3400)

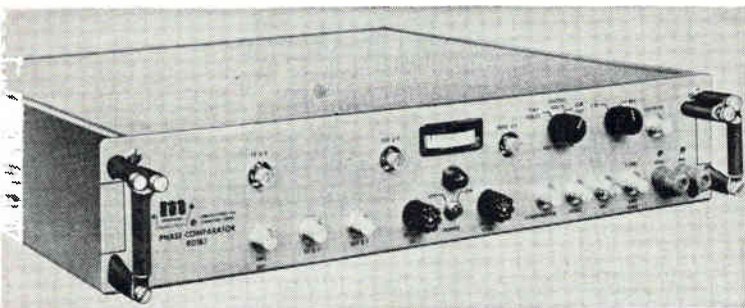

FREQUENCY

Has Large Error Expansion

SOLID-STATE frequency comparator model FDC-183 provides rapid, accurate comparisons between high-stability oscillators, calibrates frequency standards, counters and precision oscillators, and furnishes short and long-term stability measurements. The device has up to 10,000 times error expansion and contains both an internal power supply and an emergency nickel-cadmium battery pack.

Model FDC-183 will accept unknown reference inputs of 100 kc,

1 Mc, 2.5 Mc, 5 Mc and 10 Mc. Internally, the unknown frequency is compared with a 1-Mc reference input whose aging rate and frequency are known. The difference between the two is multiplied and mixed to produce an output that is a multiple of the error signal. The frequency difference can be multiplied by 10, 100 or 1,000 through front panel jacks and a multiplication factor as high as 10,000 can be achieved at the 100-kc input source. The latter permits com-

parison between signals that are separated in frequency by as much as 0.2 cps at 100 kc. Sensitivity at a 1-second count is 1 part in 10^9 , or 1 part in 10^{10} for a ten-second count. Monitoring provisions include connections for an oscilloscope, an a-f meter, a frequency counter or a strip-line recorder; these functions are selectable from the front panel. Manson Laboratories, Inc., Box 1214, 375 Fairfield Ave., Stamford, Conn.

CIRCLE 301, READER SERVICE CARD

Drivers Operate Nixies Directly

TWO new high-density Nixie tube drivers are available in both round and rectangular packs for use with corresponding tube types. The BIP-8500 and BIP-8501 each contain 10 transistors connected in a common-emitter configuration and are designed to operate Nixie tubes from low-level input signals. These driver units are binary-coded decimal-to-decimal decoders that operate the tubes directly from 8-4-2-1

binary-coded decimal information.

Both the packs mount directly on the rear of Nixie tube sockets and are available either with standard connectors for insertion into the company's SK-150 receptacles or with solder lugs for direct wiring into equipment panels. The transistor driver sells for \$30, while the decoder packages are priced at \$68 each. Burroughs Corp., Electronic Components Div., Plainfield, N. J. (302)

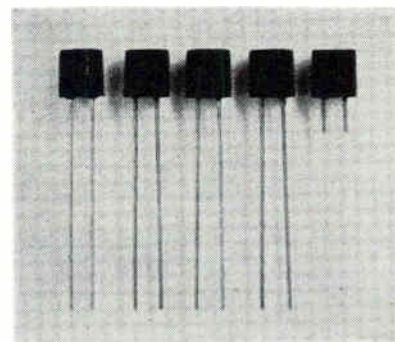

two-terminal, non-reactive, non-polarized semiconductor breaker that detects and completely opens a circuit within nanoseconds. Units are designed to eliminate failures caused by erroneous signal switching, misapplied power and transient currents. The units will pinpoint fault currents and may be reset. Hypersensors are rated at 40 volts maximum and can be supplied for rated currents of 100, 200 and 300 ma in the 100 series, and 10, 30 and 50 ma in the 200 series. Off resistance in open-circuit condition is 10 megohms nominal. Qualtronics

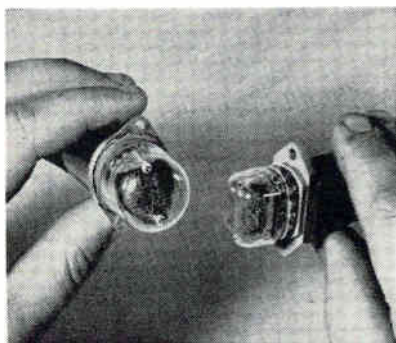

Tiny Breaker Is Non-Reactive

NEW approach to the protection of semiconductor circuits is provided by a novel circuit breaker. Called Hypersensor, the device is produced in a standard TO-18 can and is a

To Order Reprints

Fill in, cut out coupon below, insert in envelope and mail to:

electronics Reprint Dept.
 330 W. 42nd Street
 New York, N. Y. 10036

REPRINT ORDER FORM

For Listing of Reprints Available
 See Reader Service Card

(To help expedite mailing of your reprints please send cash, check or money order with your order.)

For Reprints of the latest Special Report; Materials for Space Age Electronics

Send me Reprints of Key No. R-42 at 50¢ each.

For Reprints of previous Special Reports or Feature Articles fill in below:

Send me . . . Reprints of Key No.(s) . . . @ . . . ¢ each.
 (For prices, see Reader Service Card.)

* For orders of Bulk Reprints of other editorial articles in this issue or past issues:

Send me . . . Reprints of pages no.(s) of issue date of article entitled

* Minimum bulk order 100 copies. You will be advised of costs by return mail.

Name

Number and Street

City, Zone No., State

Now SYSTEMS & SUBSYSTEMS COMPONENTS for INPUT - OUTPUT EQUIPMENT

INVAC Corporation announces for the first time its completely solid state on-line and off-line equipment for special punched paper tape applications.

This off-the-shelf equipment provides for system flexibility . . . military applications — low RFI — uses photoelectric principle to eliminate electrical contacts.

Fast delivery assured — large or small quantities. For additional information write or call: Area Code 617 899-2380.

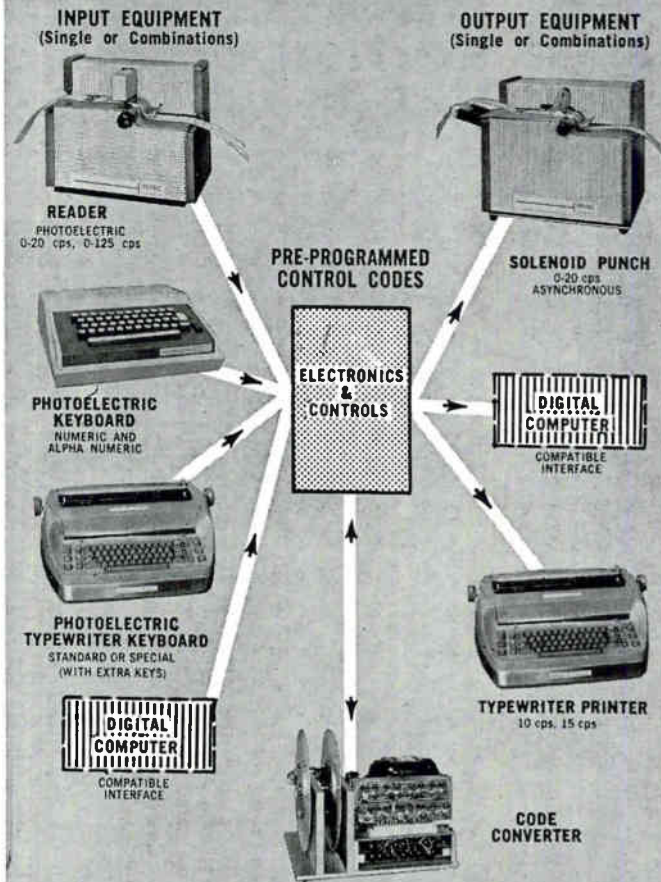

INVAC
CORPORATION

26 FOX ROAD • WALTHAM 54, MASS. Area Code 617 - 899-2380

specify the new Microdot Products
contact Avnet for best service

AVNET

on-time delivery of Microdot
Connectors and cable

Multipin connectors with up to 61
power or 19 coaxial contacts in
1½" o.d. plug; microminiature coax
connectors in 50, 70, 90 ohm types;
coax, twinax, triaxial cables (RG
types approved to MIL-C-17C).

many other Microdot Products are
available immediately from Avnet

MICRODOT

call your local Avnet Headquarters
The Avnet System, coast to coast



Westbury, L. I.; Chicago; Phoenix;
Burlington, Mass.; Syracuse, N. Y.;

LOCAL

Salt Lake City; Bellevue, Wash.;
San Diego, L. A., Sunnyvale, Cal.

CIRCLE 204 ON READER SERVICE CARD

Magnetic Reed

Relays - Coils

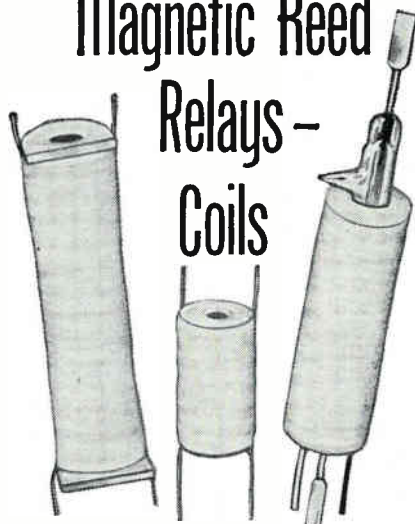

Basic and special REED RELAYS and/or COILS
for high reliability and sophisticated switching.

Operating Inputs: low as 1mA. and 15mW.

Standard Coil Voltages: 6, 12, 24, 32, 48V in stock
for immediate delivery.

Special Voltage or Resistance, multiple windings for
flip flop, memory and crosspoint selection applica-
tions — to customer specifications.

New Type SP Coils: for high voltage vacuum-type
reeds, 1½" lg.

Standard Coil Termination: 3" flexible leads. Also
available with solid copper leads, printed circuit
pins and rigid lugs — silver plated or tinned.

Relay Contacts in Form A, B, C and latching.

Coto-Coil

Write for Prices

COMPANY, INC.
65 Pavilion Ave.
Providence, R. I. 02905

Corp., 1100-1 East Ash Ave, Ful-
lerton, Calif.

CIRCLE 303, READER SERVICE CARD

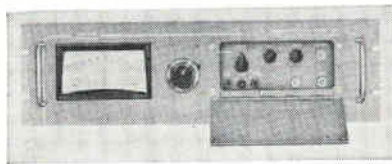

Servo Amplifier Features Low Drift

MODEL 571 servo amplifier features
a low drift of less than 20 μ v per
day and 5 μ v per deg C. It is de-
signed to take advantage of the
improved linearity of feedback po-
tentiometers that are now avail-
able for use in high-speed high-
precision electro-hydraulic control
systems. Other features include a
gain of 10^7 at d-c, an input im-
pedance greater than 1 megohm,
and an output up to ± 50 v at
3 w. The amplifier has a high ca-
pactive load-carrying capability of
greater than 0.1 μ f. Completely
flexible, the all solid-state model 571
has adjustments for gain, compensa-
tion and dither. Boonshaft and
Fuchs, Inc., Hatboro Industrial
Park, Hatboro, Pa. (304)

Shock Tester for Small Components

AUTOMATED shock testing machine
for testing small sized components
where identical shock pulses are re-
quired is announced. One or several
test objects are rigidly mounted on
a freely movable carriage, which is
raised, dropped and locked in its

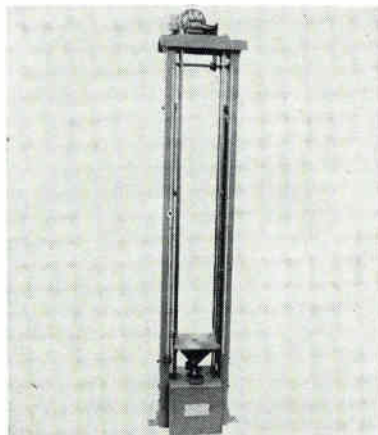

peak rebound position automati-
cally. Test cycles of 250 to 500 per
hr are provided. Since the carriage
rebound is unimpeded and is locked
against rebound shocks at its zero
acceleration point, negative pulses
are eliminated. The Auto-Jolta
shock testers are reported as having
successfully been field tested under
continuous operation for 18 months
at 3,000 g, 0.2 m/s without measur-
able change in the parameters of its
shock pulse. Jan Hardware Mfg.
Co. Inc., 3801 Queens Blvd.,
L. I. C., N. Y. (305)



Metal-Film Meter Uses Magnetic Pickup

MODEL 834-A is an instrument
which detects and measures the
thickness of a plated or deposited
metallic film. A small magnetic
pickup is built into the tip of a
probe, and the signals generated by
the metal film are processed in the
instrument and displayed on the
panel meter. The latter is calibrated
directly, and has full scale of 0.001
in. with minimum increment of 20
microinches. Circuitry is solid state,
and operation is directly from the
117 v 60 cps line. The sensitive
magnetic element is hermetically
sealed in the probe tip, and its zero
and calibration are independent of
temperature. Industrial Control Co.,
Central Ave. at Pinelawn, Farming-
dale, L. I., N. Y. (306)

Solid-State Amplifier Occupies Small Space

GENERAL PURPOSE amplifier, model
461A, offers wide bandwidth and
low distortion. It provides front-
panel selection of 20 or 40 db gain,
has nominal 50-ohm input imped-

OPPORTUNITIES IN MELPAR'S RAPIDLY EXPANDING ELECTRONICS DIVISION

Melpar's Electronics Division has an immediate need for Engineers to fill these important positions:

MICROWAVE RECEIVER DESIGN

Specific problems include parametric amplifiers, varactor techniques, microwave filters, ultra-stable programmable oscillators, and dual and triple channel balanced receivers for monopulse and guard antenna gating.

DATA PROCESSING SYSTEMS DESIGN

Perform the logic design of digital equipment to process real time flight data. Problems include specifying necessary digital/analog interface equipment and the design of computer systems for a variety of applications.

COMPUTER PROGRAMMING

Generate programs for fixed point real time computers to be used with special purpose digital and analog equipment.

COMMUNICATIONS

Perform design studies of terminal equipments for time frequency dodging, matched filters, adaptive highly reliable communications throughout the electromagnetic spectrum. Techniques of interest include spread spectrum circuitry, error detection and correction coding, and privacy and security circuitry.

For Further Details,
write in confidence to:

John A. Haverfield
Manager—Professional Placement

MELPAR INC.
(A Subsidiary of Westinghouse
Air Brake Co.)

**3436 ARLINGTON BLVD.
FALLS CHURCH, VA.**

(A Suburb of Washington, D.C.)

an equal opportunity employer



ance, and is designed to work into 50-ohm loads. It has a flat frequency response between 1 kc and 150 Mc, ± 1 db. Output is 0.5 v rms into a 50-ohm resistive load. Equivalent wideband input noise level is less than 40 μ v with 40 db gain. Unit measures 3 $\frac{1}{2}$ in. high, 5 $\frac{1}{8}$ in. wide, and 11 in. deep. Hewlett-Packard Co., 1501 Page Mill Rd., Palo Alto, Calif. (307)

Memory Exerciser Speeds Testing

ON THE MARKET is model MX-1 memory exerciser, a general purpose test instrument for testing and exercising random access memory systems. It is programmable from a panel of 120 rotary switches arranged as 12 multifunctional program instructions (similar to plug board programmed computer oper-

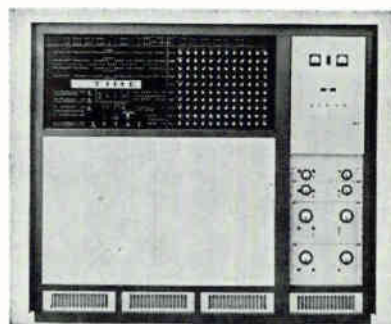

ation) for complete versatility and rapidity in testing. Looping (or transfer or jump) operations are provided so that the program may be run for an arbitrary length of time. Four arbitrary bit patterns (and their complements) are available for storage in any memory address under program control. When bit patterns are read from the memory, the exerciser tests for validity and either alarms the error or stops. Texas Instruments Inc., 3609 Buffalo Speedway, Houston, Texas. (308)

specify the new Bendix Products

AVNET

contact Avnet for best service

Pygmy* types PT, SP; Pygmy crimp types PTCE, PTSE; MS, MS-E, MS-R, QWLD, SR rack and panel

on-time delivery of emergency

BENDIX

and prototype connector needs

Reg. T.M. Bendix Corp.



call your Local Avnet Headquarters

AVNET

The Avnet System, coast to coast

CIRCLE 205 ON READER SERVICE CARD

WANT TO DO BUSINESS WITH THE GOVERNMENT

????????????

Then check the Military and Government Procurement Guide in the orange section of your ELECTRONICS BUYERS' GUIDE.

!!!!!!!!!!!!!!!!!!!!

REMOTE CONTROL/MONITORING SYSTEMS

?

MODULTONE SOLVES PROBLEMS

If multi-function monitoring or control over two wires or single radio channel is your problem, then new MODULTONE may make life easier. Here's why MODULTONE is the better way of designing and building your own systems:

- It is the most simple method.
- It is very inexpensive.
- It is easily expanded without system alteration.
- It gives maximum function with minimum weight and space.
- It is available, now.

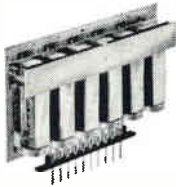

Call, wire or write for more information, Sargent & Greenleaf, Inc., 150 Bremen St., Rochester, N. Y. 14621

 **ELECTRONICS**
SARGENT & GREENLEAF, Inc.
 (formerly Security Devices Laboratory)

LITERATURE OF THE WEEK

SOLIONS Self-Organizing Systems, Inc., 6612 Denton Drive, Dallas 35, Texas. Catalog No. 105 illustrates and describes a line of solion tetrodes, solion two-terminal integrators, and solion timing devices.
CIRCLE 360, READER SERVICE CARD

COMMUNICATIONS KLYSTRONS Raytheon Co., Burlington, Mass. Bulletin gives facts and figures on two complete lines of communications klystrons. (361)

LOW-VOLTAGE VARISTORS The Carbone Corp., 400 Myrtle Ave., Boonton, N. J. Four-page brochure describes a full line of voltage-dependent resistors in which resistance decreases as applied voltage increases. (362)

PTC THERMISTORS Westinghouse Semiconductor Division, Youngwood, Pa. Technical data 54-967 covers PTC thermistors (positive temperature coefficient, thermally sensitive resistors). (363)

POTENTIOMETERS Dale Electronics, Inc., P.O. Box 488, Columbus, Neb., has issued a 40-page catalog describing a complete line of wirewound trimmer potentiometers and precision potentiometers. (364)

PRECISION COAXIAL DEVICES Weinschel Engineering, P.O. Box 577, Gaithersburg, Md., offers a complete catalog of precision coaxial devices and condensed catalog of microwave measurement instruments. (365)

HARMONIC DRIVE United Shoe Machinery Corp., Balch St., Beverly, Mass., announces availability of *Torque Talk*, a quarterly summary of engineering, application, and trade information on the harmonic drive concept. (366)

ULTRASENSITIVE ACCELEROMETER Massa Division of Cohu Electronics, Inc., 280 Lincoln St., Hingham, Mass. A data sheet describes model AC-105 ultrasensitive ADP (ammonium di-hydrogen phosphate) crystal accelerometer. (367)

ZENER DIODES National Transistor, a subsidiary of ITT, 500 Broadway, Lawrence, Mass., offers a silicon zener diode reference chart. (368)

NOR-NAND MODULES Engineered Electronics Co., 1441 E. Chestnut Ave., Santa Ana, Calif. Catalog U-93 consolidates all technical data on the U-series universal NOR-NAND silicon digital-circuit modules. (369)

VARIABLE TRANSFORMERS The Superior Electric Co., Bristol, Conn. Bulletin P463H describes Powerstat variable transformers for high frequency applications. (370)

COMMUNICATIONS TERMINAL EQUIPMENT Roanwell Corp., 180 Varick St., New York 14, N. Y., has available a 16-page catalog describing its line of communications terminal equipment. (371)

DRY REED SWITCH MicroSwitch, Freeport, Ill., announces data sheet 214 on the 1CS1 miniature dry reed switch. (372)

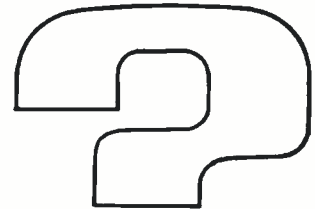

What do you need to know about

PURE FERRIC OXIDES MAGNETIC IRON OXIDES



Since the final quality of your production of ferrites and magnetic recording media depends on the proper use of specialized iron oxides—you'll find it mighty helpful to have the latest, authoritative technical data describing the physical and chemical characteristics of these materials. This information is available to you just for the asking. Meanwhile, here are the highlights.

PURE FERRIC OXIDES—For the production of ferrites, both hard and soft, we manufacture a complete range of iron oxides having the required chemical and physical properties. They are produced in both the spheroidal and acicular shapes with average particle diameters from 0.2 to 0.8 microns. Impurities such as soluble salts, silica, alumina and calcium are at a minimum while Fe₂O₃ assay is 99.5+%. A Tech Report tabulating complete chemical analysis, particle shape, particle size distribution, surface area, etc., of several types of ferric oxides, hydrated ferric oxide, and ferroso-ferric oxide is available.

MAGNETIC IRON OXIDES—For magnetic recording—audio, video, computer, and instrumentation tapes; memory drums; cinema film striping; magnetic inks; carbon transfers; etc.—we produce special magnetic iron oxides with a range of controlled magnetic properties. Both the black ferroso-ferric and brown gamma ferric oxides are described in a Data Sheet listing magnetic properties of six grades.

If you have problems involving any of these materials, please let us go to work for you. We maintain fully equipped laboratories for the development of new and better inorganic materials. Write, stating your problem, to C.K. Williams & Co., Dept. 25, 640 N. 13th St., Easton, Pa.

WILLIAMS
 COLORS & PIGMENTS
Pigment Technology at its best

A Subsidiary of Chas. Pfizer & Co., Inc.

E. ST. LOUIS, ILL. · EASTON, PENNA. · EMERYVILLE, CALIF.
CIRCLE 206 ON READER SERVICE CARD
 November 22, 1963 electronics

CAPACITORS Texas Capacitor Co., 4310 Langley Road, Houston 16, Texas, has published a brochure on Mylar and foil, metalized Mylar, and Teflon and foil capacitors. (373)

RESIN DILUENT Isochem Resins Co., 221 Oak St., Providence 9, R.I. Technical data bulletin describes Isoflex, a new Isomeric aromatic that has excellent properties as a diluent and flexibilizer for epoxy resin systems. (374)

SCANNING CAPABILITIES C. P. Clare & Co., 3101 Pratt Boulevard, Chicago, Ill. Bulletin 1001 describing Clared control module scanning capabilities is now available. (375)

MICROMINIATURE SOLENOIDS Daco Instrument Co., Tillary and Prince Streets, Brooklyn, N. Y. 11201, has published "Precision Micro-miniature Solenoids", a brochure containing data of special interest to instrument designers. (376)

SWITCH SELECTOR Oak Mfg. Co., Crystal Lake, Ill., offers a switch selector which permits the user to dial his switch design size and obtain a large amount of essential information about the company's switch line in a condensed amount of space. On the back is a 24-in. circular slide rule. (377)

READOUT TUBES National Electronics, Inc., Geneva, Ill., is offering bulletin SB-26, an 8-page booklet on numerical readout tubes. (378)

POWER CONNECTORS Continental Connector Corp., 34-63 56th St., Woodside 77, N. Y., has available a 16-page catalog on series 250 miniature rectangular rack and panel power connectors. (379)

D/A CONVERTER Siltronics, Inc., Route 286, R.D. No. 1, Pitcairn, Pa. 15140. Bulletin describes the Akra-Verter, a highly accurate and stable static digital to analog converter. (380)

SUPERCONDUCTIVE MAGNET SYSTEMS Magnion Inc., 198 Albany St., Cambridge 39, Mass. A 4-page folder describes a line of standard and custom superconducting magnets and magnet systems. (381)

R-F MILLIVOLTMETER Porter Electronic Laboratories, 209-211 Myrtle Ave., Boonton, N. J. 07005. A 4-page brochure contains specifications and applications information on the PEL626 r-f millivoltmeter. (382)

RELAYS James Electronics, Inc., 4050 N. Rockwell St., Chicago, Ill. Advanced concepts in high speed switching are featured in Micro-Scan relay catalog F-5174. (383)

TUNING FORK OSCILLATORS Fork Standards, Inc., 1915 N. Harlem Ave., Chicago 35, Ill. Bulletin No. 62-B illustrates and describes a line of tuning fork oscillators and dividers. (384)

ADSORBENT GLASS Corning Glass Works, Corning, N. Y. Physical properties of Vycor brand "thirsty" glass are described in a 2-page brochure, *Materials for Electronics*, Issue 3. (385)

POLYCARBONATE RESIN General Electric Co., One Plastics Ave., Pittsfield, Mass. Brochure contains 12 charts and graphs comparing the features of Lexan polycarbonate resin with die cast metals and other thermoplastics. (386)

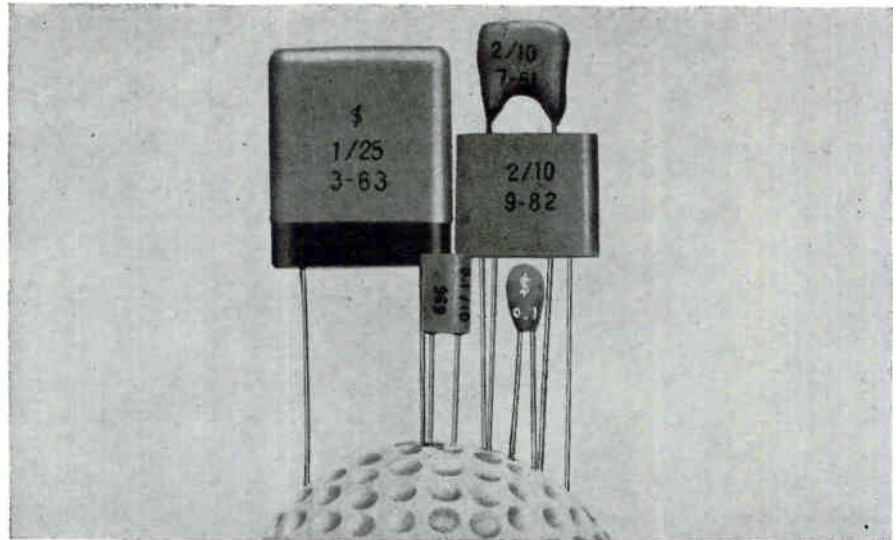

The Fujitsu 'Aloxcon' A New Electrolytic Capacitor:

The high quality of tantalum at the low cost of aluminum. Designed for use in printed and transistorized circuits, Fujitsu's newly developed aluminum solid electrolytic capacitor 'Aloxcon' functions effectively at temperatures ranging from -60°C to -80°C and frequencies up to 100 kc or more. A semiconductor layer replaces the usual type of electrolytic and so the capacitance of an 'Aloxcon' is less affected by temperature and frequency than other types. 'Aloxcon' capacitors are highly resistant to moisture, and have low leakage current and extremely high life expectancy. They are ideal for transistor circuits requiring low impedance and miniaturization. Detailed specifications and application data available from our representatives.

Type	Voltage/ Capacitance	Working Voltage(V)	Surge Voltage(V)	Capacitance (mt)						
AZ (Dipped)		6	8					0.1	0.2	0.5
GZ (Encased)		10	12	0.01	0.02	0.05	0.1	0.1	0.2	
		25	30			0.05	0.1			
AR (Dipped)		6	8					1	2	5
DR (Encased)		10	12			0.5	1	2	5	10
		25	30	0.1	0.2	0.5	1	2	5	10
HR (Hermetically Sealed)		6	8					1	2	5
		10	12			0.5	1	2	5	10
		25	30	0.1	0.2	0.5	1	2	5	10



FUJITSU LIMITED
Communications and Electronics
Tokyo, Japan

Represented by: U.S.A.: THE NISSHO AMERICAN CORP. 80 Pine St., New York 5, N.Y., Phone: WH 3-7840 THE NISSHO PACIFIC CORP. 120 Montgomery St., San Francisco 4, California, Phone: YU 2-7901/7906 CANADA: NISSHO (CANADA) LTD. 100 University Avenue, Toronto, Phone: EM 2-4794 UNITED KINGDOM: WALMORE ELECTRONICS LIMIED 11-15 Betterton Street, Drury Lane, London W.C. 2. Phone: TEM 0201-5 GERMANY: NEUMULLER & CO. GMBH 8 München 13, Schraudolphstr. 2a Phone: 29 97 24 SCANDINAVIA: SCANDINAVIAN PRODUCE COMPANY A.B. Kungsbroplan 2, Stockholm K, Sweden, Phone: 53 04 36, 53 04 51

CIRCLE 63 ON READER SERVICE CARD

**HELP YOUR POST OFFICE
TO SERVE YOU BETTER
BY
MAILING EARLY IN THE DAY
NATIONWIDE IMPROVED MAIL SERVICE
PROGRAM**

Space-General Expands

A NEW BUILDING, leased to provide needed production space for Space-General Corporation's Manufacturing division, has been added to the company's growing facilities in El Monte, Calif. Operations there have already begun, according to Paul J. Meeks, division director.

"Activation of the facility is the first step in the long term development of a competitive manufacturing capability to take full advantage of the business opportunities generated through company research and development," he said.

Initially, the 12,320-sq ft building will be used for the engineering and production of electronic equipment for the Atlantic Missile Range under a contract with the Air Force Missile Test Center.

The Manufacturing division was organized in July

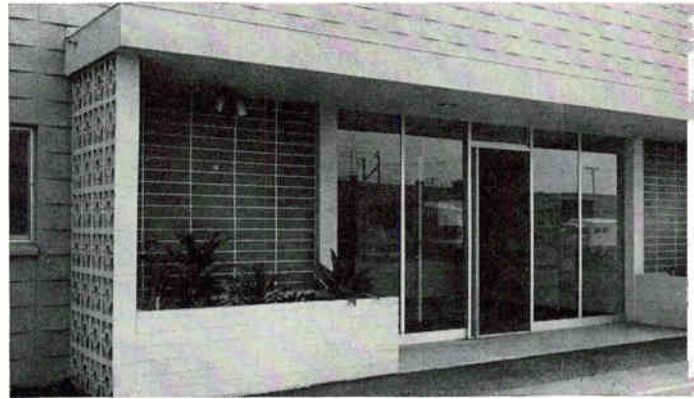

to provide for the expansion of the company's electronics and space systems programs beyond the research and development stage.

Space-General Corporation is a subsidiary of the Aerojet-General Corp.



Dunbar Accepts Executive Post

ALEXANDER H. DUNBAR has been appointed vice president, manufacturing, for FXR, Danbury, Conn. FXR is the RF Products and Microwave division of Amphenol-Borg Electronics Corp. Dunbar was formerly with Crouse-Hinds Co., Syracuse, N. Y.

FXR manufactures radio-frequency connectors, cables and switches; microwave components, test equipment and systems.

General Electric Promotes Brayshaw

STANIER E. BRAYSHAW has been appointed to the newly created post of manager of advanced development engineering for the Lynchburg

Operation of the General Electric Company's Rectifier Components department in Lynchburg, Va. He will be responsible for expanding advanced developmental activities in the selenium field for the company.

Brayshaw was president of an electronics firm bearing his name until joining GE in July.



Radiation Elects Boyd President

NEWLY ELECTED president and chief executive officer of Radiation Incorporated, Melbourne, Fla., is Joseph A. Boyd. Homer R. Denius, president of Radiation since it was founded by George S. Shaw and himself in 1950, will continue in the post of chairman of the board of directors to which he was elected in 1961.

Prior to joining Radiation in

January of 1962 as a vice president and assistant to the president, Boyd held the post of director of the Institute of Science & Technology at the University of Michigan.

Polarad Names

Pollack to Board

HERBERT W. POLLACK of Polarad Electronics Corp., Long Island City, N.Y., has been elected a vice president of the corporation and a member of the board of directors.

Pollack will continue to function as president of the Polarad Electronic Instruments division, which develops and manufactures microwave and electronic test equipment, including signal generators, receivers, spectrum analyzers, and field intensity measurement equipment.

Delta-f Moves to Pennsylvania

THE MANUFACTURING facilities of Delta-f, Inc., have been moved to the Mt. Holly Springs, Pa. plant of McCoy Electronics Co., and its business, formerly conducted in Crystal Lake, Ill., will be operated as a division of McCoy.

Both companies are owned by

SIDE-LOOKING RADAR SYSTEMS ANALYSTS

New programs at HUGHES are generating opportunities for Systems Analysts experienced in high-resolution data gathering, data transfer and data processing systems. Openings exist for Systems Engineers, Mathematicians and Physicists qualified in synthetic array radars, optical, and other data collection systems (IR, Electro-Optical, SIGINT and others). Assignments include:

Senior Systems Scientist with 20 years' electronic systems experience—at least 10 years relevant to side-looking radar systems. Applicants will be considered for important program management responsibilities. M. S. or Ph. D. degree required.

Senior Systems Analysts with 10 years' electronic systems experience—at least 5 years relevant to high-resolution systems pre-design and evaluation. Applicants will be considered for assignments in concept formulation; single and multi-sensor applications; data transmission, processing and interpretation; systems integration and performance evaluation. M. S. or Ph. D. required.

Systems Analysts with 5 years' experience in: detection of signals in noise, optimum filter theory, non-linear signal processing, information theory, MTI and doppler systems analysis. B. S. or M. S. required.

Please airmail your resume to:

MR. ROBERT A. MARTIN
Head of Employment
Hughes Aerospace Divisions
11940 W. Jefferson Blvd.
Culver City 67, California

Creating a new world with electronics

HUGHES

HUGHES AIRCRAFT COMPANY
AEROSPACE DIVISIONS

U. S. CITIZENSHIP REQUIRED
An equal opportunity employer.

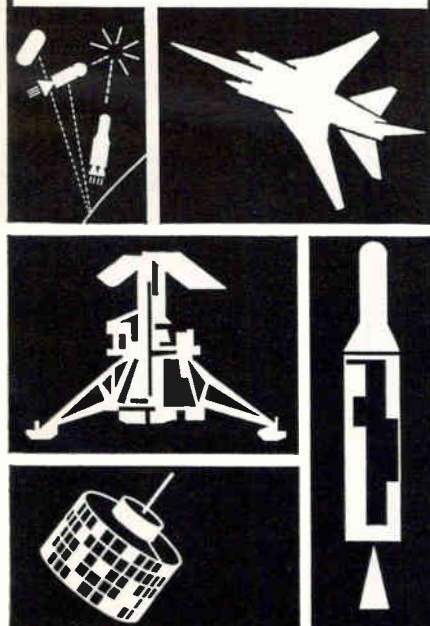

Oak Mfg. Co., components manufacturer for the electronics and electrical industries.

Delta-f is now in the 24,000-sq-ft plant in which McCoy has conducted its operations since 1952. Concurrent with the Delta-f move, McCoy began to move into its new 50,000-sq-ft plant which will more than double the firm's productive capacity.



General Instrument Appoints Miner

APPOINTMENT of Carroll R. Miner as director of engineering at the Chicopee plant of the F. W. Sickles division of General Instrument Corporation has been announced. In this position he will be responsible for the full technical research, design and development capabilities of the organization.

Miner was formerly with Sarkes Tarzian Inc., where he was in charge of new product development.



Sierra Electric Elects Ramsing

ROBERT E. V. RAMSING has been elected executive vice president and general manager of Sierra Electric Corp., Gardena, Calif., by its board of directors. He was formerly vice

NEXUS HAS PROUDLY PRESENTED

industry's first

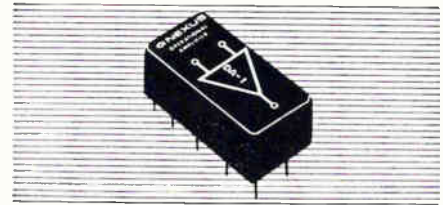

DA-1, miniature, fully encapsulated, full performance (Gain of 10,000) SOLID STATE OPERATIONAL AMPLIFIER available from stock — 0.9 cu. in. — \$105 list

industry's smallest

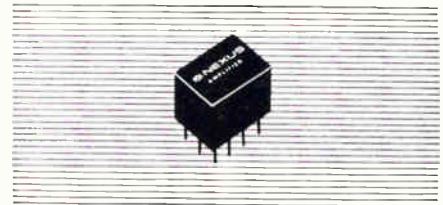

MCA-1, full performance (Gain of 20,000) SOLID STATE OPERATIONAL AMPLIFIER Operation to 85°C • All silicon—0.3 cu. in.— \$195 list

industry's least expensive

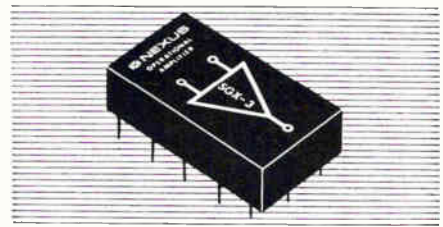

SGX-3, full performance (Min. Gain of 10,000) SOLID STATE OPERATIONAL AMPLIFIER Operation to 55°C — 1.5 cu. in. — \$40 list

AND NOW PRESENTS *industry's most potent*

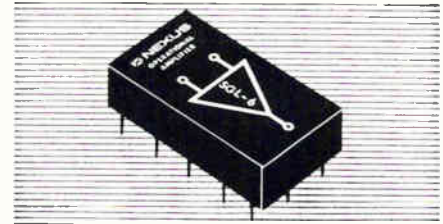

SGL-6, ±20 MA @ ±10 Volt Output (Typical Gain of 500,000) SOLID STATE OPERATIONAL AMPLIFIER Completely protected against input & output overload — 1.5 cu. in. — \$80 list Many other types available. Call or write

NEXUS
RESEARCH LABORATORY, INC.
19 Needham St., Dedham, Mass., Tel. 617 326-8414

EMPLOYMENT **electronics** OPPORTUNITIES
WEEKLY QUALIFICATION FORM
FOR POSITIONS AVAILABLE

ATTENTION: ENGINEERS, SCIENTISTS, PHYSICISTS

This Qualification Form is designed to help you advance in the electronics industry. It is unique and compact. Designed with the assistance of professional personnel management, it isolates specific experience in electronics and deals only in essential background information. The advertisers listed here are seeking professional experience. Fill in the Qualification Form below.

STRICTLY CONFIDENTIAL

Your Qualification Form will be handled as "Strictly Confidential" by ELECTRONICS. Our processing system is such that your form will be forwarded within 24 hours to the proper executives in the companies you select. You will be contacted at your home by the interested companies.

WHAT TO DO

1. Review the positions in the advertisements.
2. Select those for which you qualify.
3. Notice the key numbers.
4. Circle the corresponding key number below the Qualification Form.
5. Fill out the form completely. Please print clearly.
6. Mail to: Classified Advertising Div., ELECTRONICS, Box 12, New York, N. Y. 10036.

COMPANY	SEE PAGE	KEY #
ACF INDUSTRIES INC. Albuquerque, New Mexico	66	1
ATOMIC PERSONNEL INC. Philadelphia, Pa.	97*	2
BAUSCH & LOMB INC. Rochester, New York	66	3
LOCKHEED MISSILES & SPACE CO. Div. of Lockheed Aircraft Corp. Sunnyvale, California	73*	4
MELPAR INC. Sub. of Westinghouse Air Brake Co. Falls Church, Virginia	61	5
SPACE-GENERAL CORP. A Subsidiary of Aerojet-General Corp. El Monte, Calif.	45	6

* These advertisements appeared in the Nov. 15 issue.

(cut here) **electronics WEEKLY QUALIFICATION FORM FOR POSITIONS AVAILABLE** (cut here)
 (Please type or print clearly. Necessary for reproduction.)
Personal Background

NAME
 HOME ADDRESS
 CITY ZONE STATE
 HOME TELEPHONE

Education

PROFESSIONAL DEGREE(S)
 MAJOR(S)
 UNIVERSITY
 DATE(S)

FIELDS OF EXPERIENCE (Please Check)

112263

- | | | |
|--|--|---------------------------------------|
| <input type="checkbox"/> Aerospace | <input type="checkbox"/> Fire Control | <input type="checkbox"/> Radar |
| <input type="checkbox"/> Antennas | <input type="checkbox"/> Human Factors | <input type="checkbox"/> Radio-TV |
| <input type="checkbox"/> ASW | <input type="checkbox"/> Infrared | <input type="checkbox"/> Simulators |
| <input type="checkbox"/> Circuits | <input type="checkbox"/> Instrumentation | <input type="checkbox"/> Solid State |
| <input type="checkbox"/> Communications | <input type="checkbox"/> Medicine | <input type="checkbox"/> Telemetry |
| <input type="checkbox"/> Components | <input type="checkbox"/> Microwave | <input type="checkbox"/> Transformers |
| <input type="checkbox"/> Computers | <input type="checkbox"/> Navigation | <input type="checkbox"/> Other |
| <input type="checkbox"/> ECM | <input type="checkbox"/> Operations Research | <input type="checkbox"/> |
| <input type="checkbox"/> Electron Tubes | <input type="checkbox"/> Optics | <input type="checkbox"/> |
| <input type="checkbox"/> Engineering Writing | <input type="checkbox"/> Packaging | <input type="checkbox"/> |

CATEGORY OF SPECIALIZATION

Please indicate number of months experience on proper lines.

	Technical Experience (Months)	Supervisory Experience (Months)
RESEARCH (pure, fundamental, basic)
RESEARCH (Applied)
SYSTEMS (New Concepts)
DEVELOPMENT (Model)
DESIGN (Product)
MANUFACTURING (Product)
FIELD (Service)
SALES (Proposals & Products)

CIRCLE KEY NUMBERS OF ABOVE COMPANIES' POSITIONS THAT INTEREST YOU

1 2 3 4 5 6 7 8 9 10 11 12 13 14 15

**ELECTRONIC
 CIRCUIT DESIGNERS
 ELECTRONIC ENGINEERS**

Bausch & Lomb

has openings for EXPERIENCED ENGINEERS IN R & D AND PRODUCT DESIGN SECTIONS.

Products are Scientific Instruments (Bio-Medical, Analytical, measuring, recording instruments, etc.) Mechanical-Electrical Optical in nature. Ability to take electronic design responsibility from concept to saleable product, Engineering Degree (BS or MSEE) required, experience desirable.

Positions entail circuit design and testing, co-ordination of customer requirements with Mechanical and Optical Engineers, supervision of detail draftsmen and technicians, assistance to Production Engineers on factory problems and follow up on special customer designs.

Those who can qualify and are interested in real design responsibility are invited to send resume with salary requirements to E. P. Faro, Professional Employment, Bausch and Lomb, Inc., 17 Bausch Street, Rochester, New York.

AN EQUAL OPPORTUNITY EMPLOYER

**ALBUQUERQUE
 DIVISION**

**ACF INDUSTRIES
 INCORPORATED**

**A Prime Contractor for the
 Atomic Energy Commission**

*Now is the time for you to advance
 into the exciting and limitless*

NUCLEAR PROPULSION FIELD

We have openings for:

ELECTRICAL/ELECTRONIC ENGINEERS

to participate in the development and testing associated with nuclear propulsion and other programs in the nuclear field. Experience level required varies, ranging from three years upward. Some are supervisory positions.

BSEE degree and U. S. citizenship required. Albuquerque, a city of 260,000, provides an attractive working environment with excellent schools, two universities (we have a liberal educational benefits plan for those who wish to continue their studies), numerous churches, a complete range of cultural and recreational activities and a sunny, dry, healthful climate that remains pleasant and mild winter and summer.

Send resume to:
 General Supervisor,
 Professional Recruiting
 Albuquerque Division,
 ACF Industries, Incorporated
 P. O. Box 1666,
 Albuquerque, New Mexico

ALL APPLICANTS WILL RECEIVE CONSIDERATION FOR EMPLOYMENT WITHOUT REGARD TO RACE, CREED, COLOR, OR NATIONAL ORIGIN.

INDEX TO ADVERTISERS

Analab Instrument Corp.	6
• Avnet Electronics Corp.	60, 61
Beaver Gear Works, Inc.	56
Brush Instruments Div. of Clevite Corp.	3rd cover
Capitol Radio Engineering Insti- tute, The	40
• Clairex Corp.	41
College Hill Industries, Inc.	52
Coto-Coil Co., Inc.	60
Fluke Mfg. Co., Inc., John	56
Fujitsu Ltd.	63
Gardner-Denver Company	53
General Radio Co.	2nd cover
Hayes, Inc. C. I.	57
• Hewlett-Packard Company	4
Howcor Div. of Howard Ind., Inc.	44
Hughes Aircraft Co. Aerospace Divisions	65
International Diode Corp.	56
ITT, Electron Tube Div.	47
• ITT, Industrial Laboratories Div.	48
Invac Corp.	59
Levin and Son, Inc., Louis	42

Machlett Laboratories, The	15
Mallory and Co., Inc., P. R.	8, 9, 55
Melpar Inc.	61
Mitsubishi Electric Corp.	16
Nexus Research Laboratory, Inc.	65
North Atlantic Industries, Inc.	49
• Origin Electric Co., Ltd.	42
Pennsalt Chemicals Corp.	22
Polaroid Corp.	39
Radio Corporation of America 4th cover	
Rauland Corp., The	7
Sargent & Greenleaf, Inc.	62
Space-General Corp.	45
Space Technology Laboratories	21
Sprague Electric Co.	3
• Tektronix, Inc.	13
Texas Instruments Incorporated Industrial Products Group	43
Thiokol Chemical Corp.	50
West Penn Power	66
• Williams & Co., C. K.	62

CLASSIFIED ADVERTISING

F. J. Eberle, Business Mgr. (2557)	
EMPLOYMENT OPPORTUNITIES ..	67
EQUIPMENT (Used or Surplus New) For Sale	66
WANTED	66

CLASSIFIED ADVERTISERS INDEX

ACF Industries, Incorp.	67
Bausch and Lomb Inc.	67
Binswanger Corporation	66
Ealing Corporation	66
Plishner, P. J.	66
• Radio Research Instrument Co.	66
• Universal Relay Corp.	66

• See advertisement in the July 25, 1963 issue of electronics Buyers' Guide for complete line of products or services.

This Index and our Reader Service Numbers are published as a service. Every precaution is taken to make them accurate, but electronics assumes no responsibilities for errors or omissions.

electronics



AUDITED PAID CIRCULATION

JAMES T. HAUPTLI (2210)
Advertising Sales Manager
HENRY M. SHAW (3485)
Market Research Manager
DAVID M. TEMPEST (3139)
Promotion Manager

electronics Buyers' Guide

R. S. QUINT (2335)
General Manager

RICHARD J. TOMLINSON (3191)
Business Manager
THEODORE R. GEIPEL (2044)
Production Manager

NEW YORK TELEPHONE: Dial Direct:
971 plus number in parenthesis,
Area Code 212

ADVERTISING REPRESENTATIVES

ATLANTA, GA. 30309
Michael H. Miller, Robert C. Johnson
1375 Peachtree St. N.E.,
Trinity 5-0523 (area code 404)

BOSTON, MASS. 02116
William S. Hodgkinson
McGraw-Hill Building, Copley Square,
Congress 2-1160 (area code 617)

CHICAGO, ILL. 60611
Harvey W. Wernecke,
Robert M. Denmead
645 North Michigan Avenue,
Mohawk 4-5800 (area code 312)

CLEVELAND, OHIO 44113
Paul T. Fegley
55 Public Square, Superior 1-7000
(area code 216)

DALLAS, TEXAS 75201
Frank Le Beau
The Vaughn Bldg.,
1712 Commerce St.
Riverside 7-9721 (area code 214)

DENVER, COLO. 80202
John W. Patten
Tower Bldg., 1700 Broadway,
Alpine 5-2981 (area code 303)

HOUSTON, TEXAS 77025
Kenneth George
Prudential Bldg., Halcombe Blvd.,
Riverside 8-1280 (area code 713)

LOS ANGELES, CALIF. 90017
Ashley P. Hartman, John G. Zisch,
1125 W. 6th St., Huntley 2-5450
(area code 213)

NEW YORK, N. Y. 10036
Donald H. Miller (212) 971 3615
George F. Werner (212) 971 3617
Donald R. Furth (212) 971 3616
500 Fifth Avenue

PHILADELPHIA, PA. 19103
Warren H. Gardner, William J. Boyle
6 Penn Center Plaza,
LOCust 8-4330 (area code 215)

SAN FRANCISCO, CALIF. 94111
Richard C. Alcorn
255 California Street,
Douglas 2-4600 (area code 415)

LONDON W1:
Edwin S. Murphy Jr.
34 Dover St.

FRANKFURT/Main:
Matthee Herfurth
85 Westendstrasse

GENEVA:
Michael R. Zeynel
2 Place du Port

TOKYO:
George Olcott,
1, Kotohiracho, Shiba, Minato-ku

Signal on
conventional channel
width

40mm

Identical signal
on Mark 280 channel width

80mm



New! Brush records 35 cps full scale on 80mm

The new portable **Mark 280** doubles resolution of traces without sacrificing frequency response! And . . . you get instantaneous rectilinear ink records of unparalleled accuracy and clarity. Forced fluid writing presents traces, at frequencies to 35 cps full scale, on low cost chart paper. Dual channels each have 50 divisions in an 80 mm width, with trace width constant at one-tenth of a chart division. So now, you can easily detect minute signal variations and take *full* advantage of a $\frac{1}{2}\%$ system accuracy. Matched solid-state amplifiers provide a sensitivity of 0.5 millivolts/div. Operating controls include attenuator, pen-position, variable gain and 12 push-button chart speeds. No other recorder can match the total capability of the Mark 280. Write for details.

brush INSTRUMENTS

DIVISION OF CLEVITE 37TH AND PERKINS, CLEVELAND 14, OHIO

CIRCLE 901 ON READER SERVICE CARD

1952-



RCA introduced the 6146

RCA DESIGNED:

- Small, sturdy structure
- High efficiency
- High power sensitivity

Early 1963-



RCA announced improved-design 6146A

RCA ADDED:

- "Dark Heater"
- Controlled power output at reduced heater voltage
- Controlled zero-bias plate current

NOW-



RCA-6146B/8298A with even more improvements

- Higher plate dissipation and plate current ratings
- Withstands heater overvoltage
- Higher temperature operation
- Higher power output

GET HIGHER POWER OUTPUT IN NEW EQUIPMENT DESIGNS

Now! Use and specify the RCA-6146B/8298A. This new RCA Beam Power Tube at once brings more power in new equipment designs and extended tube life in renewal use. In existing 6146, 6146A and 8298 sockets, RCA-6146B/8298A can give extended life while offering OEM designers increased power capability.

A direct result of RCA's power-tube research, the RCA-6146B/8298A permits higher plate dissipation (35 watts max. CW ICAS) for increased plate current. It also offers all the advantages of improved performance and mechanical stability that only RCA "Dark Heater" tech-

GET EXTENDED LIFE WHEN REPLACING 6146, 6146A or 8298

nology provides. At normal heater ratings, capabilities are: 85 watts CW output (ICAS) at 60 Mc; 50 watts CW output (ICAS) at 175 Mc.

In fixed station use, 6.3 volts is the recommended value for the tube's "Dark Heater." In mobile service, the tube operates efficiently over a range of heater voltages from 5 volts to 8 volts.

For further details on the RCA-6146B/8298A, consult your RCA Representative. For a technical bulletin, write: Commercial Engineering, Section K-19-Q, RCA Electronic Components and Devices, Harrison, N.J.

AVAILABLE THROUGH YOUR AUTHORIZED RCA INDUSTRIAL TUBE DISTRIBUTOR



The Most Trusted Name in Electronics