

electronics

NEW LASER MATERIAL?

Cadmium sulfide shows injection luminescence

(photo below)

MAJORITY LOGIC FOR COMPUTERS

Can actually save in circuit layout

DATA DISPLAY IN MICROSECONDS

Character waveforms write on cathode-ray tube

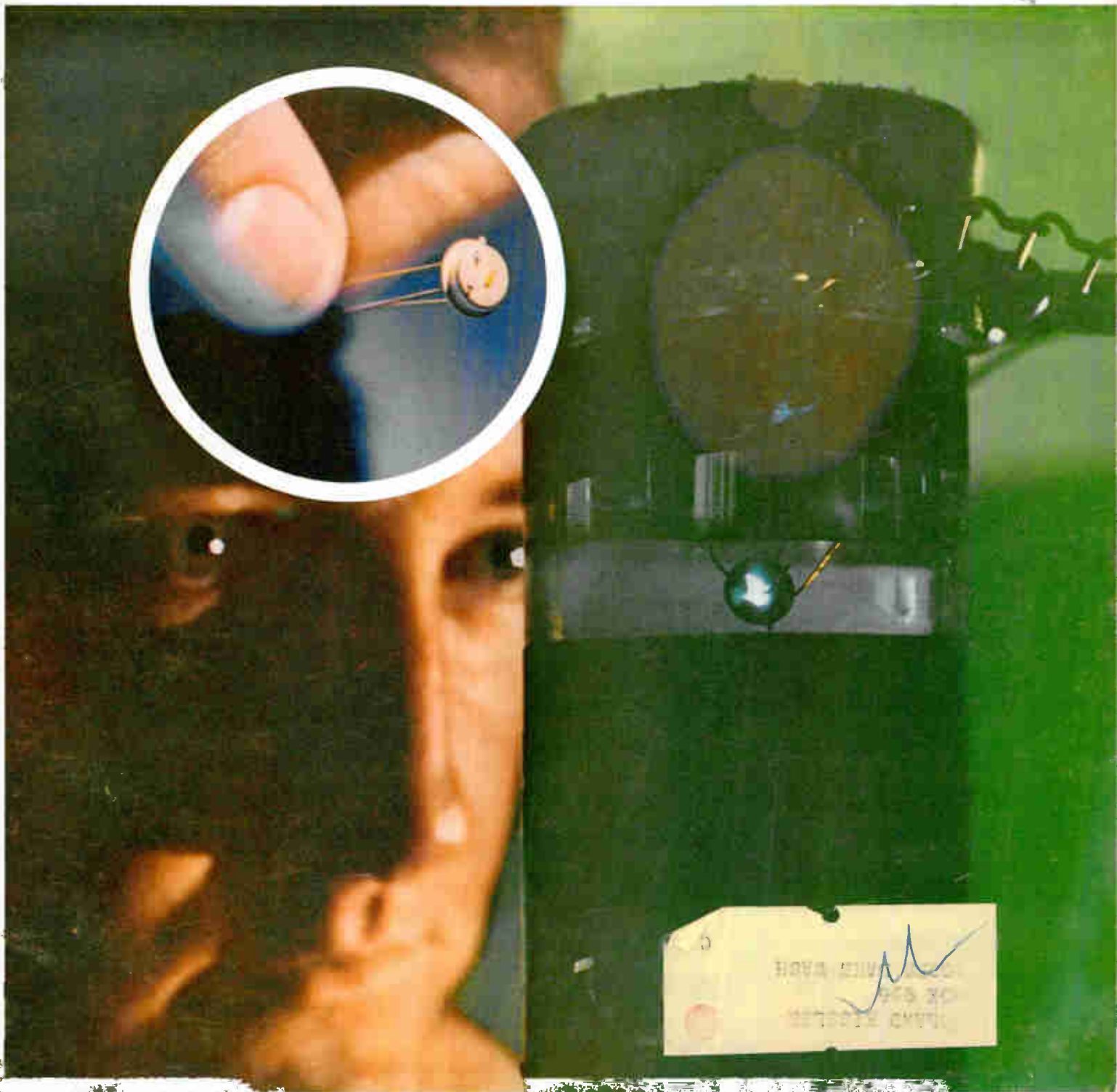
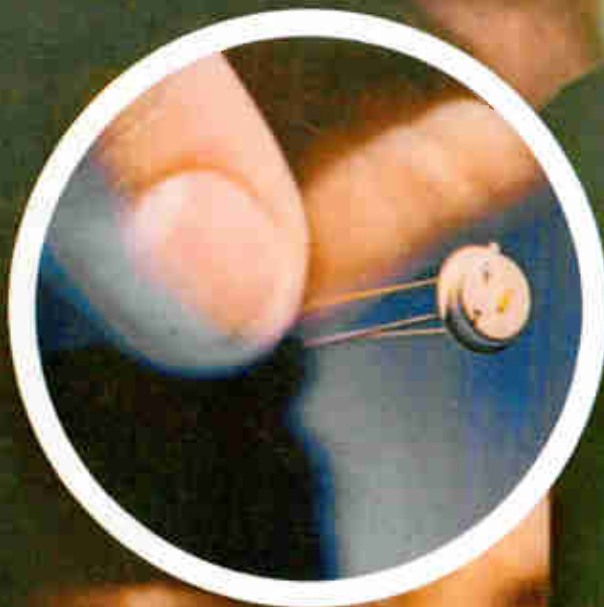

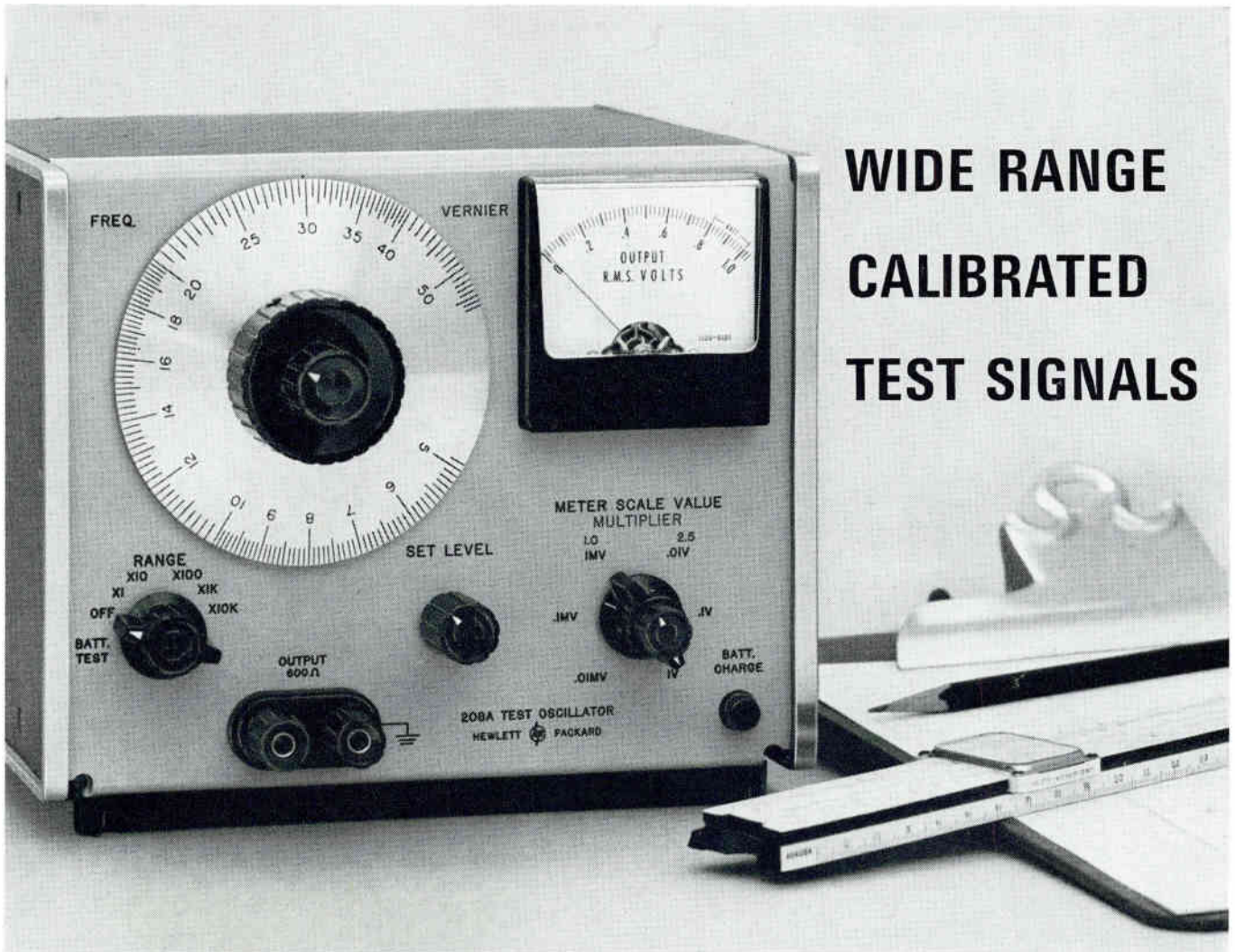

WIDE RANGE CALIBRATED TEST SIGNALS

5 cps to 560 kc, 5 μ v to 2.5 v into 600 ohms

SPECIFICATIONS

- Frequency range:** 5 cps to 560 kc, 5 ranges
- Dial:** logarithmic calibration, \pm 3% accuracy
- Frequency response:** \pm 3% into rated load
- Output:** 10 mw (nominal 2.5 v rms into 600 ohms)
- Output impedance:** 600 ohms
- Output attenuator:** 6 position, 10:1 steps from 0.01 mv to 1 v; times 2.5 multiplier gives 10:1 steps from 0.025 mv to 2.5 v
- Output monitor:** transistor voltmeter monitors level at input to attenuator and after set level
- Set level:** continuously variable attenuator with 10:1 (20 db) minimum range
- Distortion:** less than 1%
- Hum and noise:** less than 0.05%
- Power:** four rechargeable batteries (furnished), recharge during ac operation; 30 hours per charge, more than 500 recharges
- Size:** 6½" high, 7¾" wide, 8" deep, 8¼ lbs.
- Price:** hp 208A, \$525

Data subject to change without notice. Prices f.o.b. factory.

Also available: Model 208A-DB for audio, communication system testing. Model 208A-DB, same as 208A except that output is calibrated in dbm, has a 110 db attenuator calibrated in 1 and 10 db steps. Price: \$535.

New hp 208A Test Oscillator

Solid state and operated from a rechargeable battery pack or ac line, the 208A can be used anywhere to provide stable, accurate signals that are calibrated with a built-in attenuator and voltmeter. The precision attenuator adjusts the output in 20 db steps from 0.01 mv to 1 v or from 0.025 mv to 2.5 v. A metered set level control provides continuous adjustment between 20 db steps. Output is calibrated into 600 ohms, single ended.

While operation on rechargeable battery pack makes the 208A ideal for field use, battery operation is also useful in general lab work, providing isolation from power line ground to avoid hum and ground loop problems. The long-life nickel-cadmium batteries recharge automatically while the oscillator is operated from the ac line so that the 208A is always ready for portable use. Output is flat within \pm 3%; frequency stability is typically better than 5 parts in 10⁴.

This portable source of stable, wide range, calibrated test signals can save you time and trouble. Call your hp field sales office today for a trial on your bench.



HEWLETT-PACKARD COMPANY

1501 Page Mill Road, Palo Alto, Calif. 94304, (415) 326-7000. Sales and service in all principal areas. Europe, Hewlett-Packard S.A., 54 Route des Acacias, Geneva, Switzerland; Canada, Hewlett-Packard (Canada) Ltd., 8270 Mayrand St., Montreal, Que.

8636

W. W. MacDONALD, Editor
Telephone Area Code 212 (971-2645)

J. M. CARROLL, Managing Editor (2293)

SENIOR EDITORS

Samuel Weber (2371)
George W. Sideris (3444)

SENIOR ASSOCIATE EDITORS

Michael F. Wolff (2600)
John F. Mason (2666)

ASSOCIATE EDITORS

Michael F. Tomaino (2071)
William P. O'Brien (2297)
George J. Flynn (2188)
George V. Novotny (3151)
Leon H. Dulberger (3446)
Alexander A. McKenzie (2685)

ASSISTANT EDITORS

Stephen B. Gray (2245)
Barry A. Briskman (2306)
Dan Smith (2467)
Joel A. Strasser (2127)
Vincent S. Acunto (2592)
C. R. Whetstone (3495)
Eric Valentine (2710)
Louis S. Gomolak (2472)

REGIONAL EDITORS

Harold C. Hood,
1125 W. 6th St., Los Angeles 90017, Calif.
(213-482-5450)
Laurence D. Shergalis,
John Hancock Bldg., 255 California St.,
San Francisco 94111, Calif. (415-362-4600)
Thomas Maguire
McGraw-Hill Bldg., 607 Boylston St.,
Boston 02116, Mass. (617-262-1160)
Cletus M. Wiley,
Blair Bldg., 645 N. Michigan Ave.,
Chicago 60611, Ill. (312-664-5800)

ART DIRECTOR

Howard R. Berry (2430)

ASSISTANT ART DIRECTOR

John C. Wright, Jr. (3430)

EDITORIAL ASSISTANTS

Lorraine Rossi, Virginia T. Bastian,
Lynn Emery, Ann Mella, Lorraine Werner,
Alice M. O'Brien, Sharon Parks,
Claire Benell, Kay Fontana,
Sandra A. Le Mond, Mary Jo Jadin

FOREIGN NEWS BUREAU

DIRECTOR, John Wilhelm, (2532);
Lawrence Mihlon (2997), Alyne Elias
(2998)

LONDON—John Shinn, Derek Barlow,
Nicholas Landon, 34 Dover St., London
W.1, England

BONN—Bruce Bendow, Richard Mikton,
Silke McQueen, Mittelstrasse 39, Bad
Godesberg, Germany

BRUSSELS—27 Rue Ducarle, Brussels,
Belgium

PARIS—Robert Farrell, Arthur Erikson,
17 Ave. Matignon, 3rd Fl., Paris 8,
France

MILAN—Marc A. Messina, Via Manzoni
No. 12, Milan, Italy

MEXICO CITY—Wesley Perry, Jr.,
Lafraqua 4-314, Mexico 1 D.F. Mexico

RIO DE JANEIRO—Leslie Warren, Rua
Mexico 3-S/1507 1509, Rio de Janeiro,
Brazil

MOSCOW—Stewart Ramsey,
Kutuzovsky Prospekt 19, Apt. 28-29,
Moscow, USSR

TOKYO—Richard Halloran, Charles Cohen,
John Yamaguchi, Toranomom Sangyo
Bldg., 1 Kotohiracho Shiba, Minato-Ku,
Tokyo, Japan

CIRCULATION MANAGER

Hugh J. Quinn (2310)

C. C. RANDOLPH, Publisher (2016)

electronics

A MCGRAW-HILL WEEKLY 75 CENTS

INJECTION ELECTROLUMINESCENCE device of polished cadmium sulfide doped with indium chloride peaks at 5,000 Å. Injection and recombination radiation occur at 1-v forward bias. The 20 × 20 × 50-mil crystal is mounted on a TO-5 header (inset). *The Westinghouse Electric device is suspended in liquid nitrogen and driven by a full-wave, 60-cps rectifier. See p 46*

COVER

ARMY AIR SURVEILLANCE. As part of its program to develop its own air-support force, Army is buying a variety of airborne sensors. *Helicopter armaments are also on the R&D list*

10

MESUCORA. Last week, French industry and government cooperated in an exhibit showing their latest developments in measuring, control, regulation and automation equipments. *Among the new ones: computer process controls*

14

MAJORITY AND THRESHOLD LOGIC WITH SEMICONDUCTORS. Majority logic has been proposed as a means for increasing reliability in computing and control circuits. The broader subject of threshold logic is of major importance in adaptive circuits. Actually majority logic can save circuits in conventional applications. *Here is how to realize majority logic using transistors, diodes and tunnel diodes.*

By W. A. Sauer, General Electric

23

DATA-DISPLAY SYSTEM WORKS IN MICROSECONDS.

Conventional readout devices often cannot follow the operations of on-line data processors. This display system applies character-writing waveforms to a cathode-ray tube. *Writing rate is 50,000 characters a second; system can produce 12 different displays.*

By F. W. Kime and A. Hartley-Smith, Marconi

26

CONICAL SCAN ARRAY USES VARIABLE PHASE SHIFTERS.

This development was required to simplify a mono-pulse automatic tracking system that had to operate over a bandwidth of a decade or more. The antenna is a cluster of four parabolic reflectors arranged in a diamond and using a frequency-independent feeds. *Variable phase shifters in series with each element provide conical scan for error-signal generation.*

By L. R. Young, C. A. Lovejoy
and L. E. Williams, Radiation, Inc.

30

CONVERTING ONE-TRACE SCOPES TO RASTER DISPLAY.

Display of digital data necessary in trouble-shooting systems is limited by the resolution of the oscilloscope used. Raster oscilloscopes boost resolution but are expensive and hard to move around. *This circuit, using a dozen transistors, can convert a conventional oscilloscope for raster scanning; it weighs only 5 lb.*

By B. S. White, Univ. of Calif.

33

Published weekly, with Electronics Buyers' Guide as part of the subscription, by McGraw-Hill Publishing Company, Inc. Founder: James H. McGraw (1860-1948).

Title ® registered U.S. Patent Office; © copyright 1963 by McGraw-Hill Publishing Co., Inc. All rights reserved, including the right to reproduce the contents of this publication, in whole or in part.

Executive, editorial, circulation and advertising offices: McGraw-Hill Building, 330 West 42nd Street, New York, N. Y., 10036. Telephone Area Code 212 971-3333. Teletype TWX N. Y. 212-640-4646. Cable McGrawhill, N. Y. PRINTED IN ALBANY, N. Y.; second class postage paid at Albany, N. Y.

OFFICERS OF THE PUBLICATIONS DIVISION: Shelton Fisher, President; Vice Presidents: Joseph H. Allen, Operations; John R. Callahan, Editorial; Ervin E. DeGraff, Circulation; Donald C. McGraw, Jr., Advertising Sales; Angelo R. Venezian, Marketing.

OFFICERS OF THE CORPORATION: Donald C. McGraw, President; Hugh J. Kelly, Harry L. Waddell, L. Keith Goodrich, Executive Vice Presidents; John L. McGraw, Treasurer; John J. Cooke, Vice President and Secretary.

Subscriptions are solicited only from those actively engaged in the field of the publication. Position and company connection must be indicated on orders. Subscription rates: United States and Possessions and Canada, \$6.00 one year, \$9.00 two years, \$12.00 three years. All other countries \$20.00 one year. Single copies, United States and Possessions and Canada 75¢. Single copies all other countries \$1.50.

THE PUBLISHER, UPON WRITTEN REQUEST TO OUR NEW YORK OFFICE FROM ANY SUBSCRIBER, AGREES TO REFUND THAT PART OF THE SUBSCRIPTION PRICE APPLYING TO COPIES NOT YET MAILED.

Subscribers: Please send change of address notices, subscription orders or complaints to Fulfillment Manager, Electronics, at the address below. Change of address notices should provide old as well as new address, including postal zone number if any. If possible, attach address label from recent issue. Allow one month for change to become effective.

Postmaster: Please send Form 3579 to Fulfillment Manager, Electronics, P. O. Box 430, Hightstown, New Jersey, 08520.



Audited Paid Circulation

Contents continued

F-M DISCRIMINATOR WITHOUT TUNED CIRCUITS. The problem was to measure frequency modulation with deviations of 1 cps at rates of from zero to 100 cps. A discriminator using L-C components did not seem to fill the bill. *The answer was to use R-C networks in the feedback loop of a cascode amplifier to simulate the tuned circuits.*
By H. D. Crawford, Oklahoma State Univ., and A. B. Hale, USAF 36

LOOPLESS RDF. Quasi-doppler radio direction finder for airport use has dipole arrays to receive uhf and uhf signals from planes. *It will be used to guide planes in emergencies* 38

PART-TIME TELEMETRY. NASA's new interplanetary probe will only sample space data and send it to earth in bursts. *Data-reduction systems need work only part-time on the data* 40

ELECTROLUMINESCENT DOSIMETER. Phosphor absorbs radiation energy, puts out light when heated. *Readout is digital and remote* 41

R-F REPEATER. Novel microwave repeater system handles signals at r-f, doesn't use i-f. Solid-state system uses parametric amplifiers. *The only one built is going to Formosa* 42

DEPARTMENTS

Crosstalk. Army's Sky Force 5

Comment. Mysterious Signals. Plaudit 6

Electronics Newsletter 17

Meetings Ahead. IEEE, ISA Region 6 Annual Conference 18

Washington This Week 20

Research and Development. New Field-Effect Device May Aid Integrated-Circuit Design 44

Components and Materials. Diodes Tolerate High Radiation 48

Production Techniques. What Makes Solder Joints Good? 50

New Products. Oscillators Exhibit High Stability 52

Literature of the Week 55

People and Plants. Cutler-Hammer Elects President 56

Index to Advertisers 60

new Allen-Bradley Type JJV Hot Molded Variable Resistors with "built-in" vernier

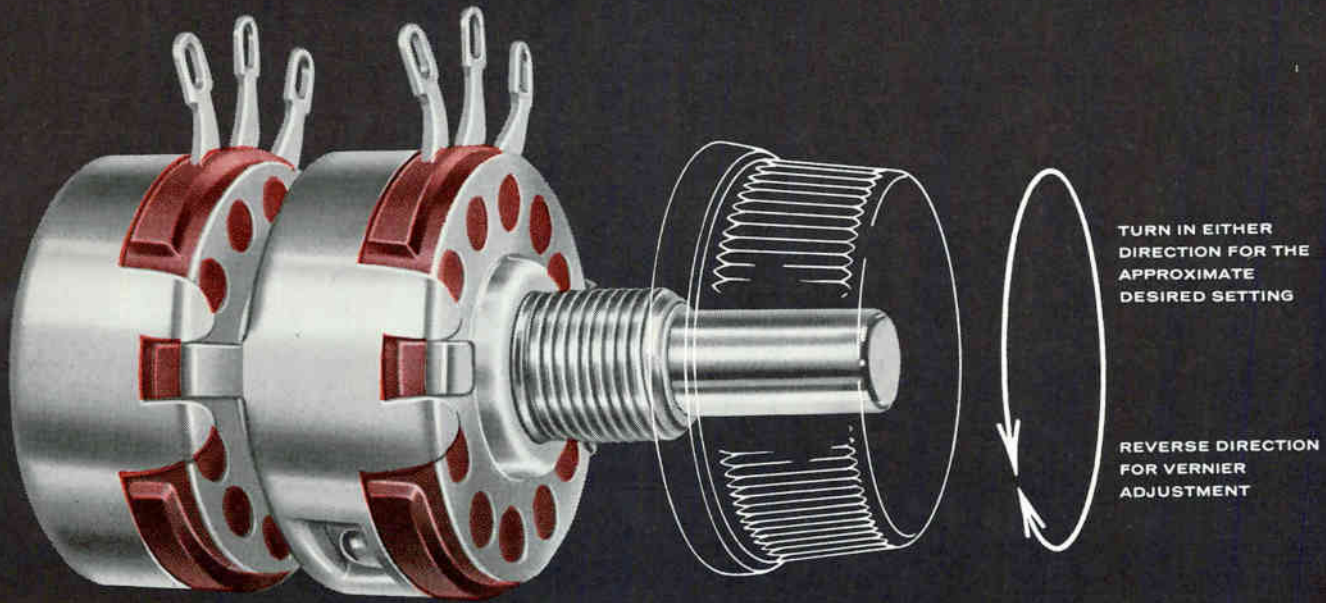

TYPE JJV VERNIER CONTROL
Shown Twice Actual Size

TURN IN EITHER DIRECTION FOR THE APPROXIMATE DESIRED SETTING

REVERSE DIRECTION FOR VERNIER ADJUSTMENT

TURN ONE KNOB—you obtain both the approximate setting and the fine resistance adjustments . . . *in the panel space of only one control.* A unique coupling arrangement allows the approximate setting to "idle" when the operator is making the vernier adjustment. More than 12% of total rotation is available for the independent vernier adjustment, thus providing up to 20 times better resolution than is obtainable with a single element control.

VERSATILE—All standard tapers and resistances are available to satisfy virtually any control requirement. Can be used as a rheostat or as a modified potentiometer in a three or four terminal circuit. A triple control, having two units locked together with the third unit

providing the vernier adjustment, is available where true potentiometer circuitry is required.

FAMOUS TYPE J PERFORMANCE—The exclusive hot molded resistance element with its built-in stability is a guarantee of long operating life and having a low initial noise level, which is further improved with use. The control is always smooth and during adjustment is completely free of sudden changes or "steps."

Try this new Type JJV control—surprise yourself with the vernier resistance adjustment that is obtainable over a wide range. Allen-Bradley Co., 110 W. Greenfield Ave., Milwaukee, Wis. 53204. In Canada: Allen-Bradley Canada Ltd., Galt, Ont.

ALLEN-BRADLEY TYPE J HOT MOLDED VARIABLE RESISTORS



Type J
with encapsulation



Type JS
with line switch



Type JJ
standard dual unit



Type JJJ
standard triple unit



ALLEN-BRADLEY

QUALITY ELECTRONIC COMPONENTS

Performance advantages of a better broadband instrumentation tape

—in pre-detection, pulse code modulation, and other critical high-frequency instrumentation recording applications.

The shortest wavelengths in broadband recording are less than five times those of visible light. To magnetically record and reproduce such wavelengths requires a tape surface smoothness approaching that of an optical surface.

Memorex Type 62 Broadband Tapes look smooth to the eye, but what is more important, they look smooth even to the electron microscope — competitive products do not. They are twice as smooth as the best competitive tape, and this near-perfect surface is produced unerringly over the miles of tape on each roll.

Electron microphotographs of surfaces of Memorex tape and competitive product at the same magnification (6000x).

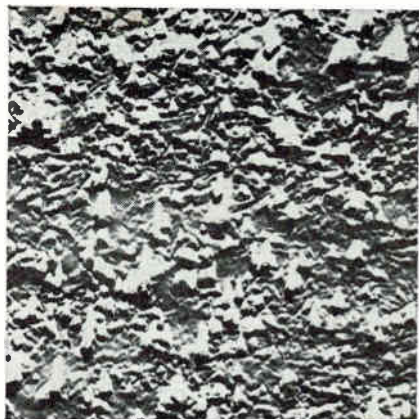

MEMOREX TAPE



LEADING COMPETITIVE TAPE

Users of Memorex Type 62 Broadband Tapes receive important performance advantages, including:

as much as 6 db more response at the highest frequency—the result of the ultra-smooth surface;

as much as 3 db greater undistorted output — the result of a coating more densely packed with well-oriented particles of oxide;

more than 3 db higher signal-to-noise ratio—the result of extreme uniformity of distribution of particles within the coating;

no measurable increase in dropouts, even after 100 plays — the result of scrupulous cleanliness and care in manufacturing and the use of a durable, electrically conductive coating which will not shed oxide.

These improvements in performance were measured on a Mincom CM 100. Still greater improvements can be expected when using recorders with more extended bandwidth.

Memorex broadband tapes offer you a wider choice of coating thickness to suit your recording application:

62J (370 μ inch coating) — for high output

62K (270 μ inch coating) — a new intermediate coating thickness

62L (170 μ inch coating) — the thinnest coating offered to date, giving you 25% more playing time per roll.

Digital or pulse recording applications—The smooth, thin coatings of Type 62 Broadband Tapes will provide the higher resolution and greater pulse packing densities required by advanced recording systems.

Memorex manufactures precision magnetic tapes for instrumentation and computer use, including Type 22 Computer Tape (tested and certified at 800 and 556 bpi), Type 33 Instrumentation Tape, Type 42 High Resolution Tape, and Type 62 Broadband Tape. To obtain complete technical data sheets, write to Memorex Corporation:

1182 Shulman Avenue / Santa Clara, Calif.

Important New Report for all Instrumentation Tape Users

MEMOREX Monograph #2, titled "Head Wear Considerations in Magnetic Tape Recording," available free on request. Write MEMOREX at address above.



**MEMOREX
CORPORATION**
PRECISION MAGNETIC TAPE



Army's Sky Force

CREATION OF ARMY'S own airlift and combat aviation facilities continues to provoke controversy in the Pentagon and concern in the Air Force.

Army's position holds that helicopters and transports that are an integral part of its field forces are necessary for battlefield mobility. They must be nearby and under the control of the Army commander—not 100 or so miles away on an Air Force field. Armed choppers and fixed wing aircraft are also considered essential for offensive action and close air support. Army claims that realization of these aims will not infringe on the Air Force mission.

USAF maintains that it will. The Air Force understands its responsibilities to include close combat air support of friendly ground forces; interdiction of enemy troop movements, supplies and communications in enemy rear areas; combat troop carrier and air cargo support; and tactical air reconnaissance.

Air Force points to its experience and good record in carrying out such missions, and to Army's lack of experience in airborne operations. USAF also believes the duplication of effort would be very expensive. Air Force agrees that Army should have some organic air support, but that too much independent reliance on low-flying, slow aircraft—vulnerable to modern enemy defense—would dissipate, rather than enhance, Army's total effectiveness.

The general climate in DOD appears favorable to the results of tests before giving the green-light for all-out implementation of the plan (reported in a series of articles including this week on p 10). Some \$66 million has been provided by DOD for these tests.

The general climate in DOD appears favorable to the new air arm. Secretary of Defense Robert McNamara was enthusiastic when he announced plans for Army's

reorientation last January, and there has been no indication since that the mood has changed. Also, the emphasis on limited war is too far-reaching to be an interim freak; it is a long-term trend.

The arguments by both Army and Air Force are believable and for the most part objective. The areas of disagreement created by interservice rivalry, however, should be ironed out as quickly as possible to prevent waste in time, effort, money and even lives.

THE STOCKROOM. In an editorial entitled *Who's Minding the Stockroom* (*Crosstalk*, Nov. 2, 1962), we urged industry to help educators keep the supply of engineering talent high. One area of the country in which industry has been doing this is Southern California. We've reported before on the work done by the Southern California Industry-Education Council (*ELECTRONICS*, p 24, Aug. 10, 1962), so won't go into the details again. But we would like to cite a late statistic: while engineering school enrollments dropped by 2.3 percent in the 1962-63 academic year—on top of steep drops in previous years—freshman enrollment in Southern California's engineering schools rose by 11.1 percent.

Coming In Our December 6 Issue

TODAY'S SEMICONDUCTORS. About two years ago (Sept. 29, 1961), we took a close look at new semiconductor materials and devices, many of them still in research. In the past few years, modern materials and device technology have birthed a host of new types, and each new type a host of technical reports. For example, this year the tunnel diode spawned a series of articles in our publication on June 14, 21, 28 and July 5. And almost every issue carries information about some advance in the art of microelectronics.

Next week's special report, entitled *Today's Semiconductors*, leads the circuit designer through the often bewildering array of new semiconductor devices and tells how to use many of them in practical circuits that crop up regularly in engineering practice.

The 24-page report will consist of three articles covering logic circuits, small-signal applications, power and control circuits. The authors are five engineers whose professional speciality is developing new circuits using semiconductor devices. The report is neither blue sky, nor does it rehash well-established practices. It tells how to use the latest commercially available semiconductor devices to solve some of the more difficult design problems now besetting circuit engineers.

Injection lasers will be the subject of a state-of-the-art report next week. Two other feature articles will describe an airborne vhf transponder that uses f-m feedback to achieve pulse stability, and a novel cascode follower for driving low-impedance loads.

CYLINDRICAL INTERFERENCE FILTERS

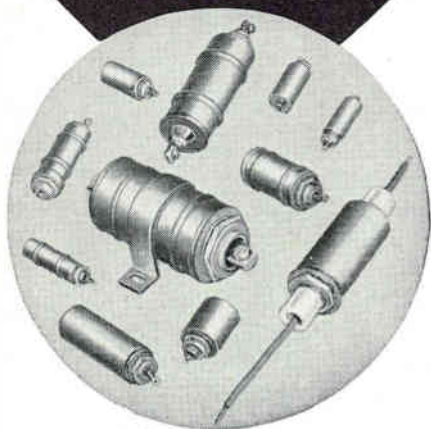

**Small...
Light...
Efficient!**

- Basic cylindrical design follows natural shape of rolled capacitor sections and toroidal inductors.
- Threaded-neck bulkhead mountings assure proper isolation between input and output terminals as well as firm peripheral mounting with minimum impedance to ground.
- Popular low pass design, intended for use as 3-terminal networks connected in series with circuits to be filtered.
- Excellent interference attenuation characteristics reflect the use of Thrupass® capacitor sections.

For additional information, write for Engineering Bulletin 8100A to Technical Literature Service, Sprague Electric Company, 35 Marshall St., North Adams, Massachusetts.



48-468 R1

COMMENT

PLAUDIT

Your *New Products* treatment of the STL Image Converter Camera (p 49, Nov. 1) is both effective and imaginative.

The montage of the schematic over the Image Converter Camera clearly shows the electronic aspect of the instrument. The crisp headline and well-written copy combine to get across an important message in your engineering readership's language.

Thank you for doing your job so well.

H. A. BERGER

STL Products
Div. of Space Technology Laboratories, Inc.
El Segundo, California

MYSTERIOUS SIGNALS

In your *Newsletter* of Nov. 8 (p 17), you included an item stating that Yale University is going to monitor the "mysterious low-frequency signals sporadically emitted from Jupiter."

It seems quite strange to me that they should be called "mysterious." Immanuel Velinkovsky, in a lecture to the Graduate College at Princeton in 1963, predicted that Jupiter would be found to emit radio noises. These were subsequently "discovered" by the Carnegie Institution in April, 1955. Why no credit to Velinkovsky? Why "mysterious"? Is this a Yale-Princeton feud?

R. K. THOMPSON

Lockheed-California Company
Burbank, California

- The signals from Jupiter were labeled "mysterious" in the Goddard Space Flight Center announcement of the award to Yale. Apparently, while the emission itself is well known, the mechanism is not.

SEMICONDUCTOR SYMBOLS

The concept that the enclosing circle had become more general than that of the tube envelope was passed on to you (*Comment*, p 6, Nov. 8) as being germane to the recent correspondence about American semiconductor symbols thus enclosed and Continental symbols which were not (p 6, Sept. 6, Sept. 13, Sept. 27, Oct. 4). At the Industry meeting at which this was brought up, several years ago, there was no dissent from the idea that effectively it had become a stage symbol. The wording from the current ASA standards is the same as for the 1954 issue and undoubtedly well-represents drafting practice at the time.

By coincidence, yesterday I saw for the first time pages 18 through 19.2 of a draft of the next standard sent out by C. R. Muller on April 12, 1963. It appears from this that there is a further development in the generalization of symbols to include enclosed or package devices. There are several terms used, ranging from "circle" alone to "envelope symbol or enclosing circle."

Possibly we are progressing to the point that the symbol is for an enclosure—or an integral unit—with the envelope being a specialized form. (I can remember when it was recognized that the envelope concept was better than the previously used "bulb" and the substitution of the former staved off several needless symbols.)

ALAN C. ROCKWOOD

Newton, Massachusetts

TRANSISTOR-RADIO JAMMER

It's interesting to see that Name Withheld has attacked directly the annoying problem of blaring transistor radios, in his letter describing two broadcast-band jammers (p 6, Nov. 22).

Unfortunately, this direct approach seems to be the only answer to the actions of the thoughtless people who insist on playing their transistor radios in public (and elsewhere) at near-top volume. In Paris, for instance, there is a law against playing a radio in the subway. But I imagine that enforcing such a law is another matter. And the police have enough other matters to keep them busy, without having to keep track of loud radios.

Of course, there is a more direct approach, but that involves assault and battery. Perhaps that's just what some of these unthinking people need—a high battery voltage applied across their terminals.

E. LIVALI

New York, New York

PRECISION MINIATURE MIL SPEC A.C. MOTORS

All motors shown are available with integral gear reducers.

TYPE SC

Sub-miniature motor rated .15 oz. in. max. sync. torque. Size: $1\frac{1}{16}$ " dia. x $1\frac{3}{16}$ " long. 2.4 oz. To 200 v.a.c. 2, 4 or 6 poles



TYPE MC

Miniature motor rated 0.8 oz. in. max. sync. torque. Size: $1\frac{1}{4}$ " dia. x $2\frac{1}{4}$ " long. 6.5 oz. To 200 v.a.c. 2, 4 or 6 poles.



TYPE FC

Small motor rated 1.2 oz. in. max. sync. torque. Size: $1\frac{1}{16}$ " dia. x $2\frac{1}{4}$ " long. 11.5 oz. To 200 v.a.c. 2, 4 or 6 poles.



TYPE YC

Small motor rated up to 12 oz. in. @ 3,000 rpm in three stack lengths. Size: $2\frac{1}{2}$ " dia. x (3 lengths) $1\frac{3}{16}$ ", $2\frac{3}{16}$ ", $3\frac{7}{16}$ ". 26 oz., max. To 230 v.a.c. 2, 4 or 6 poles.



TYPE OC

This low temperature rise motor is conservatively rated at 4.5 oz. in. max. sync. torque. Size: 3" dia. x $2\frac{3}{4}$ " long. 32 oz. To 115 v.a.c. 2, 4, 6, 8, 16 or 24 poles.



TYPE LC

Small motor rated up to 20 oz. in. max. sync. torque in two stack lengths. Size: $3\frac{5}{16}$ " dia. x (2 lengths) $3\frac{1}{8}$ " and $4\frac{1}{32}$ ". 8 lbs., max. To 200 v.a.c. 2, 4 or 8 poles.



TYPE GRL

Universal a.c./d.c. motor rated .077 hp, 5,000 to 10,000 rpm. Size: $2\frac{1}{4}$ " dia. x $4\frac{1}{32}$ " long. 36 oz. To 115 v.a.c., and 115 v.d.c.



PRECISION COMMERCIAL A.C. MOTORS

TYPE CFC

Small motor rated 2.0 oz. in. max. sync. torque. Size: $1\frac{1}{32}$ " dia. x $2\frac{7}{8}$ " long. 13 oz. To 115 v.a.c. 2, 4 or 6 poles.



TYPE CLC

Small motor rated 22 oz. in. max. sync. torque. Size: $2\frac{1}{16}$ " dia. x (2 lengths) $3\frac{7}{8}$ " and $4\frac{3}{4}$ ". 72 oz., max. To 115 v.a.c. 2, 4 or 8 poles.



TYPE CMC

Miniature 60 cycle motor rated up to 0.75 oz. in. max. sync. torque @ 1,800 or 3,600 rpm. Size: $1\frac{1}{4}$ " dia. x $2\frac{3}{32}$ " long. 7.2 oz. To 115 v.a.c., 2 and 4 poles.



TYPE UC

Small motor rated up to 12 oz. in. max. @ 3,000 rpm in three stack lengths. Size: $2\frac{1}{4}$ " dia. x (3 lengths) $1\frac{27}{32}$ ", $2\frac{11}{32}$ ", $3\frac{11}{32}$ ". 16 oz. To 230 v.a.c. 2, 4 or 6 poles.



GLOBE INDUSTRIES, INC., 1784 STANLEY AVENUE, DAYTON 4, OHIO TEL. AREA CODE 513 222-3741
PRECISION MINIATURE AC & DC MOTORS, GEARMOTORS, TIMERS, ACTUATORS, CLUTCHES, BLOWERS, MOTORIZED DEVICES

GLOBE

Looks good, doesn't it?

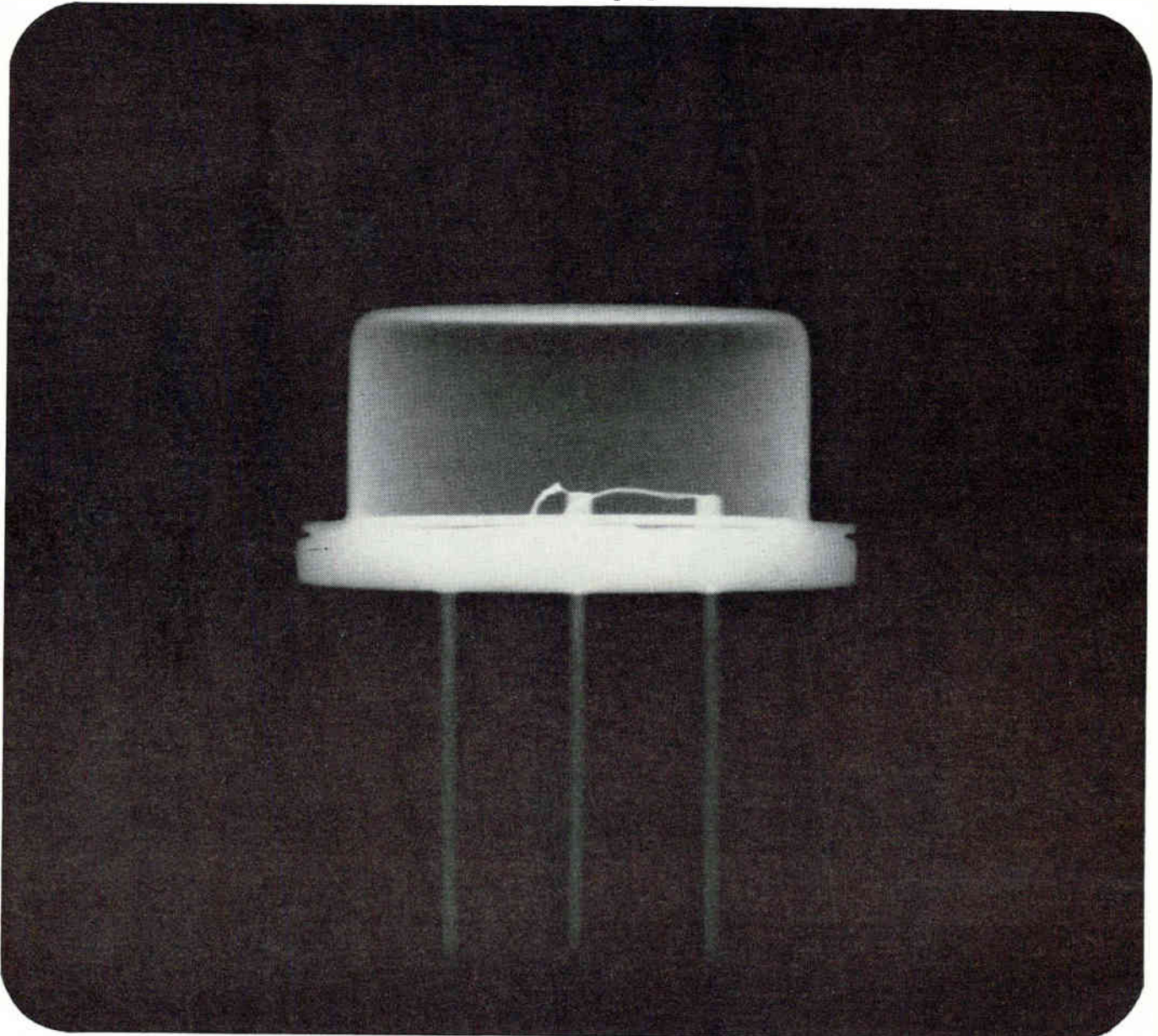

...but, look at it this way to be sure!

Appearances *can* be deceiving. Often a tiny defect can escape most methods of detection. That's why so many companies depend on Ansco Industrial X-ray films to make the final check on their components.

No method of non-destructive inspection shows up tiny imperfections, (especially in tiny components), more clearly or quickly than a radiograph on Ansco Superay® 'H-D' X-ray film.

This Class I film is especially designed for high definition radiography. It has an ultra-fine grain and very high contrast and provides the ultimate in image quality. Although used

primarily with low voltage techniques, Superay 'H-D' maintains its high definition characteristics and image quality throughout the full KvP range.

Ask your Ansco X-ray Products Representative how Ansco Industrial X-ray films and chemicals can be of significant value in your inspection procedures. He's always at your service.

 **AnSCO**
X-RAY PRODUCTS
GENERAL ANILINE & FILM CORPORATION
BINGHAMTON, NEW YORK



Shown above are the
CORNING resistors which have failed
in more than 135,000,000 (MOSTLY
OVERSTRESSED) unit test hours.

We may have a failure any year now.

In the meantime, we have calculated statistical failure rates which may change your thinking about high-reliability resistors . . . whether you are working with MIL-R-22684 (NAVY), MIL-R-10509D or MIL-R-55182. The rates look like this:

Less than 0.0015%/1000 hours. CORNING has failure rate data based on continuous life testing for periods up to 50,000 hours; nearly six years. This test is for 1800 resistors that have been on continuous life test for

60,000,000 unit hours at powers up to 140% of rated. The confidence level is 60%.

Less than 0.0012%/1000 hours. This one is based on 75,000,000 unit hours at 250% of rated power and 25°C.

CORNING resistors live through high-stress reliability programs like these because of the inherent reliability of the tin oxide and glass that go into them. They demonstrate *flat* load-life characteristics for the same reason.

High-reliability CORNING resistors are available in general purpose C-style, precision RN-type, and hermetically sealed precision NF-type. A bulletin on CORNING "Resistor Reliability" is now available. Write for your copy.

**CORNING
ELECTRONICS**

A DIVISION OF CORNING GLASS WORKS
3901 ELECTRONICS DR., RALEIGH, N. C.



HELMET FIRE control system (left) permits pilot to aim rockets and quad gun by looking at target through bulls-eye sight. Servo-actuated system moves gun (right) along with movement of pilot's head (Sperry) ▶

ARMY HOPES new tactical image interpretation facility will solve problem of screening the massive piles of surveillance photos (film, radar and ir) sent back by drones and Mohawk aircraft ▶

◀ MOHAWK SURVEILLANCE planes carry photographic cameras, side-looking radar (antenna hangs below second plane), and infrared detectors

Army Wants Surveillance, Armament



Ground Surveillance — Keeping track of what the enemy is doing is achieved by a variety of sensors, and from two perspectives: ground and air.

For the ground, a hostile artillery locator is being developed that pinpoints an offender by getting infrared (ir) bearings from two to five friendly detectors. Information from each is relayed by wire to a master plotter. The Canadians are working on a radio-relay system, results of which will be examined by the U. S. Army. Canada is also working on a detection system similar to the ir development, but which locates by acoustics rather than ir.

Sylvania is working on a new mobile radar and high-speed computer system that will detect the position of hostile artillery and direct friendly fire. Pinpointing the origin of artillery fire is more difficult than that of mortar, since the trajectory of artillery is low and flat. The AN/MPQ-32, for which sizable contracts have been awarded, will be delivered for acceptance tests some time next year.

Air Surveillance—Airborne sensors include photography, side-looking radar (slar, see ELECTRONICS, p 22, March 22), passive radar (ELEC-

Money is available for new devices to watch battle area and suppress fire

By **JOHN F. MASON**
Senior Associate Editor

WASHINGTON—Tests at Fort Benning, Ga., by Army's 11th Air Assault Division are turning up a number of equipment needs for this new fighting force (ELECTRONICS, p 32, April 12; p 10, Nov. 22).

Which of these needs will eventually be converted to new hardware depends on a variety of factors—a key one being money. How much Army gets depends on how the Defense Department feels about the whole air-assault concept when the new budget is presented to Con-

gress in January. With DOD's emphasis on limited war, prospects are excellent for continued high priority on a strong, mobile, fighting Army.

How Army will select new equipment is being determined now by realistic testing in the field—with an eye on building a force as quickly as possible plus planning for a later generation. Rather than put present effort in a new weapon-integrated helicopter that would take several years to build, Army is equipping existing helicopters with arms and will wait for a new type aircraft to be developed as a next generation weapon, such as V/STOL (ELECTRONICS, p 30, Feb. 15).

As always, the electronics industry can help DOD make decisions by providing new techniques and new weapons to do the job better than existing ones. Two big areas in which ingenuity will pay off are surveillance and armament.

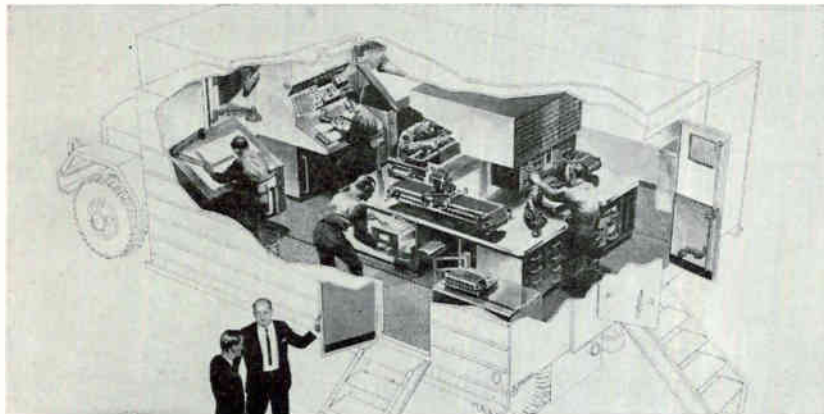
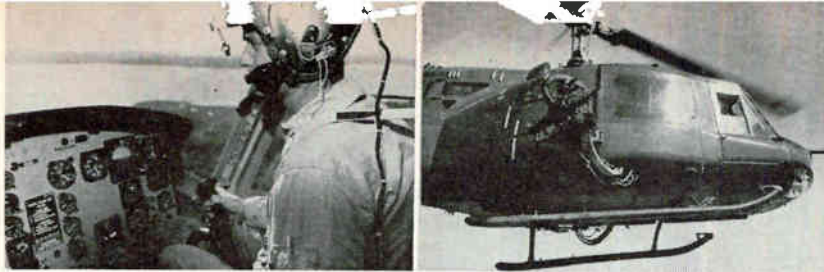

Gear for Air Arm

TRONICS, p 32, April 12), ir, and electromagnetic ferreting devices.

Operational slar, AN/APS-94-A, built by Motorola, provides permanent aerial radar maps of ground targets on either side of the flight path. The maps are photographic records on either 4 × 5-inch cut film or 70-mm strip film. A 9-inch format rapid film processor-viewer permits the observer to view the imagery in the cockpit approximately one minute after exposure. Data link transmits the radar imagery back to the ground station for display.

Radar techniques, including slar, are still under investigation by the University of Michigan, Goodyear and Philco. Advanced ir work is still active at Texas Instruments.

Data link, important for both drones and manned surveillance planes, is easily accomplished for ir and radar imagery. Photographs, however, still present difficulties. Film must be processed in the plane, and electronically scanned before transmission. A new cathode-ray-tube scanner for this purpose is being developed by the Electron Tube division of Litton Industries. Motorola is working on a wide-bandwidth data-link system for all sensors that will be compatible with

equipment used by all three military services.

Image Interpretation—Equipment to scan the massive pile of imagery sent back by airborne sensors is required by all three services. Army will soon test a truck-mounted unit known as Tactical Image-Interpretation Facilities, AN/TSQ-43, developed under a \$800,000 contract by Link division of General Precision, Inc.

Photo interpreters, communications specialists and intelligence officers stationed in the unit's van will use material derived from a variety of airborne and other sensors. The van will contain a variable power-scanning stereo viewer, zoom stereoscope and zoom microscope, a drafting machine and a photogrammetric computer.

USAF's system is being built by Fairchild Camera and Instrument. It uses a small, solid-state, militarized computer (AN/UYK-1) originally developed for Navy by Thompson-Ramo-Wooldridge.

Armament—Army will spend \$23 million in 1964 for R&D on armament for helicopters. Some \$2.4 million goes for ways to adapt new weapons to helicopters; \$3.5 million

to initiate recommendations made by the Howze Board for free-fall munitions, antiradar missiles, and weapons for visually marking the target areas. Continuance of existing programs will cost \$7.6 million for guided missiles to provide point target coverage, and machine guns for area target and suppressive area coverage. The remaining \$9.5 million will be used to continue research started in 1963. Some of this money will be spent for engineering service testing which should lead to type classification of new systems.

Although Army has the French-made SS-11, wire-guided missile for use against enemy tanks, a new missile is being sought. The SS-11 requires the pilot to hover, in view of the target, until the missile reaches the target. A new missile would be welcome that permits the pilot to sight the target, fire, and drop out of sight at once. Army Missile Command, Huntsville, Ala. is investigating solutions to this problem.

Other needs include: replacement of the 2.75-inch XM-3 rocket which weighs 18.5 pounds; and a universal fire-control system compatible with all second-generation weapons. This job is being monitored by Frankford Arsenal, Philadelphia.

Helmet Fire Control—Under the Arsenal's direction, tests were completed last month at Aberdeen Proving Ground on a helmet that allows a helicopter pilot to shoot what he sees by simply looking at his target and pressing a button. The visor of the helmet is equipped with a bulls-eye sight through which the pilot lines up the target. The armament, outside the plane, actuated by servos, automatically wheels around to face the same direction. The system, developed by Sperry Gyroscope, has been demonstrated with both rigid mounted 2.75-inch rockets and with the fully flexible .30-calibre M-6 quad gun system. Sperry has proposed to the Army an expanded system to include a computer. The rate at which the pilot turns his head to follow the target would be fed into a computer to determine lead angle. Other companies building helmet fire control systems include Honeywell, Philco, Chrysler, and Hughes.

"A GUY COULD GET KILLED IN HERE"...

... this place is like a roller-skating rink! What's all the traffic? I had to *fight* my way into the instrument room!

Oh, hello, Rip! Yes, we're doing a rush business here today! Every instrument in the joint's been in and out of here at least twice. Particularly amplifiers — just can't get 'em back here fast enough to meet all the requests!



Amplifiers? Any special types really hot right now?

Dunno. All my data-acquisition types have been out for about a week now. And all my audio amplifiers are down the hall in Dept. 23. Video amplifiers have been on the most-wanted list, too. And here are three requests for RF amplifiers I can't even fill until tomorrow at the earliest!

What you need are more amplifiers like Krohn-Hite's DCA-10 — a stable ten watts, tenth-percent distortion, wide band!

We're always using the DCA-10's you sold us — as audio amplifiers, mainly. But how about the other applications I've got to fill?

But nothing! You're short on data-acquisition types? Look — the DCA-10's direct-coupled, goes all the way down to dc. Only 0.2% distortion at .01 cps. Perfect on data circuitry. And talk about video amplifiers — the DCA-10 is one in disguise! No droop on a step function from a DCA-10, as you'd get from a capacitor-coupled amplifier! And with a megacycle bandwidth, you get a rise time in the order of 0.1 microseconds.

Yeah, the top end of a megacycle would serve the needs of many of the requests for RF amplifiers.

Now you're thinking Krohn-Hite! Actually, there's really nothing like it for the money — frequency response flat within a db all the way up, stable dc level, too, and low hum and noise.

You certainly don't have low hum and noise!

What do you expect — *I'm a rep!* Just one more thing — when you need 20 watts push-pull — two DCA-10's cascaded, one in the unity gain position, will give it to you. For *more* power, its big brother, the DCA-50 gives 50 watts single-ended or 100 watts push-pull, up to 500kc, with the *same* clean specs of the DCA-10. Now, anything else I can tell you about the DCA-10?

Yeah — price and delivery on twenty!



**KROHN-HITE
CORPORATION**

580 Massachusetts Avenue, Cambridge 39, Mass.
Area Code 617 491-3211

Pioneering in Quality Electronic Instruments

HOW TO USE YOUR ELECTRONICS BUYERS' GUIDE

Advertising Product Sections

Advertisements in the **ELECTRONICS BUYERS' GUIDE** are grouped together according to the kind of product advertised. All Power Supply advertisements, for example, will be found in the same section of the book. Thus it is made convenient for you to "shop" through the specifications presented to you by advertisers, without having to flip pages back and forth constantly. Keep your **ELECTRONICS BUYERS' GUIDE** close to your work area at all times.

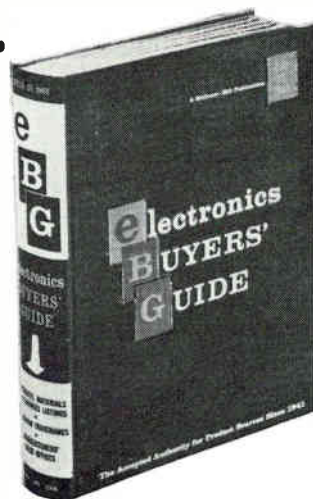

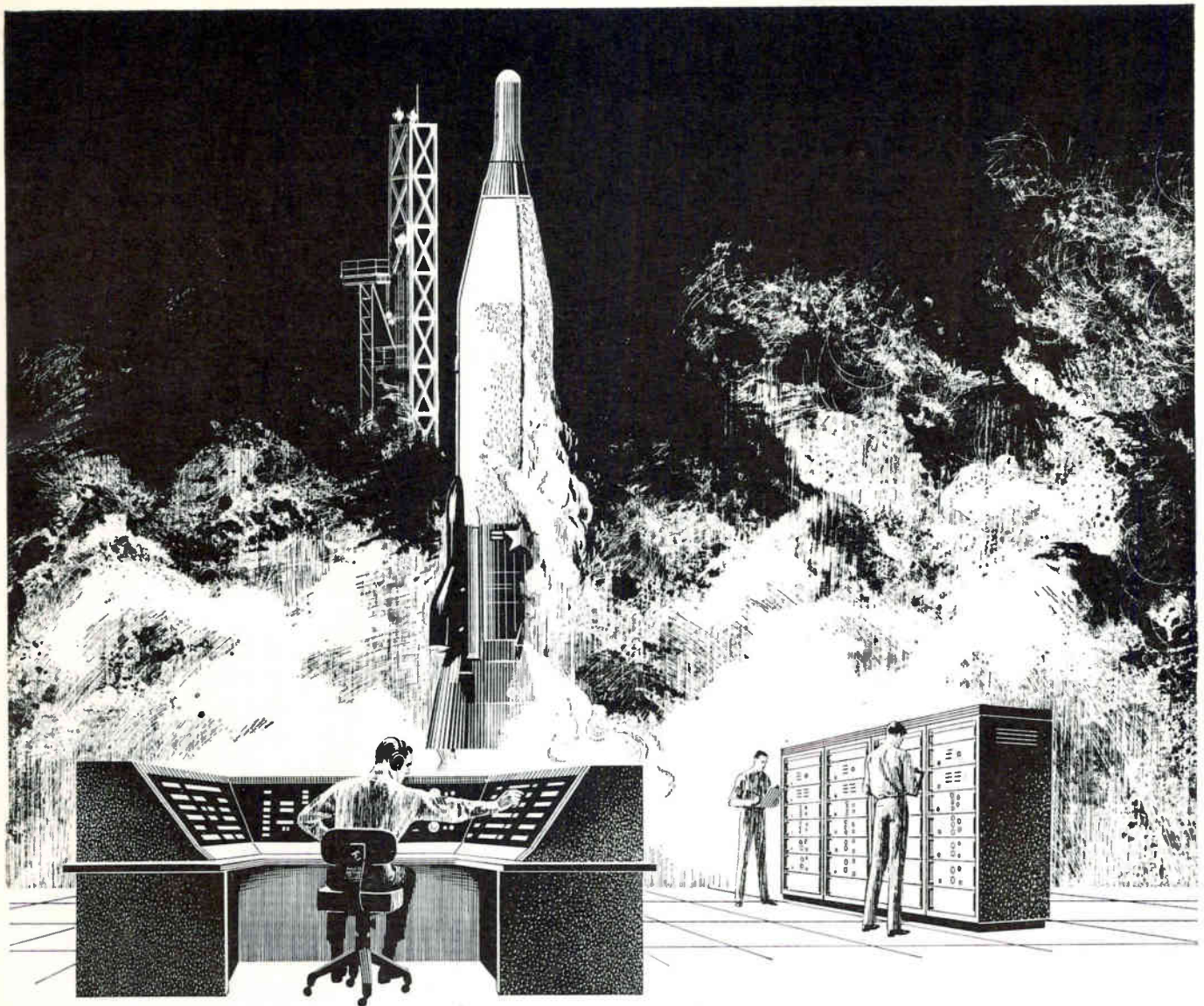

Marquardt needs electronic engineers

Marquardt's latest assignment in the missile trainer-simulator field is to develop and produce the Atlas E and F missile launch crew procedure trainers for the Air Force Ballistic Systems Division. The new Marquardt trainer represents another advance in simulation technology since it is a completely solid-state digital system. It will accurately simulate all operational procedures—from alert to launch—and will encompass the complete spectrum of malfunctions. The Marquardt systems will be used at various SAC bases to train missile combat crews who are required to operate, maintain, and control the Atlas.

Marquardt's advanced capability in trainer technology is also exemplified in other military applications, including the T-10 navigator trainer for B-52 bomber crews, T-4 manual aircraft control and warning site trainers, T-8 trainers for 412L automated air defense systems, and trainer-simulators for the GAM 77 (Hound Dog) and GAM 72/A (Quail) missiles.

Expanding programs, coupled with continuing company-sponsored research and state-of-the-art contracts, are responsible for the new assignments now open at Marquardt. Opportunities presently exist for experienced

engineers and scientists who want to affiliate with a dynamic company, well diversified in electronic systems, as well as control systems, airbreathing propulsion, and aerospace research.

Select senior personnel highly qualified in any of the following areas, will find rewarding opportunities at Marquardt: Electro-Optical Systems; Digital Systems Analysis and Logical Design; Advanced Analog and Digital Simulation Systems. Please write in confidence to Mr. Fred Clark at the address below:

Dedicated to Keeping The United States First in Technology

POMONA DIVISION

THE *Marquardt*
CORPORATION

2709 NORTH GAREY AVE., POMONA, CALIFORNIA
AN EQUAL OPPORTUNITY EMPLOYER

French Control Systems

Sophisticated, as Usual

Process-control computer slowly varies parameters and looks for best result

By **ARTHUR ERIKSON**
McGraw-Hill World News

PARIS—The Gallic penchant for sophisticated solutions popped up consistently at the 1963 Mesucora, the show for "Mesure, Controle, Regulation et Automatisme." French systems applications dominated the show, although more than half the 1,365 exhibitors were not French.

Knowledgeable visitors took an extra-long look at the French Thomson-Houston's dynamic process-optimizing computer. It slowly varies control parameters while checking if process output moves toward optimum.

Developed jointly with Batelle Institute, the computer applies exploratory signals to process-parameter controllers. As the test signals change the parameters, evolution of a figure of merit for the process is checked. If the second derivative of the figure of merit evolves toward zero, exploration continues in the same direction; if not, the sign of the test signal is reversed.

Circuits to compute the figure and regulate parameter controls are tailored to a specific process. Other circuits are universal and the computer is built around standard digital and analog modules.

A continuous control for a blast furnace, by IBM, uses a mathematical model developed in France. Gas conditions in the furnace are the only inputs to the IBM 1710—charge weight and quality don't count. From the inputs, production rate and carbon consumption are calculated, plus a figure of merit

that closely follows cast-iron quality and guides corrective steps.

To control blending of liquids, Compagnie Generale d'Automatisme has a numerical system. Proportions are set on a binary multiplier. Flowmeter pulses for each component pass through it and are compared with pulses from an oscillator or the flowmeter for the pilot fluid. Any difference is fed to a memory emptied by control signals to fluid-regulating valves. This integrates errors in time until the flow is corrected.

Alarm Systems — The geophysical equipment firm, Sercel, has put its sensitive geophones into a plant surveillance system. If anyone approaches an installation, the seismic movements actuate a remote alarm. Systems have 5 to 21 channels, each tied to a group of geophones that guard a sector. The sector setup tells the human guards where to go when an alarm sounds.

Trains rolling at 110 mph are checked for hot boxes by a system developed for the French National Railways by Compagnie des Signaux et d'Entreprises Electriques. Infrared radiation emitted by the trailing edge of each bearing box is detected by an indium-antimonide cell. The disk-modulated a-c signal is amplified by transistor circuits and goes by telephone line to a recorder in the station house. To prevent spuri-



DIGITAL VOLTMETER by Rochar Electronic was one of several small instruments at Mesucora

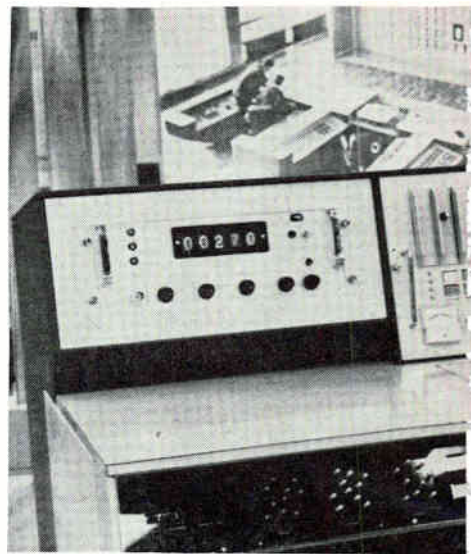

PLUG-IN CIRCUIT BOARDS program high-government laboratory and made by



BINARY circuits change program of automatic chromatograph

ous readings, amplifiers switch in only when an axle passes a magnetic mass detector. Temperature detection range is 30 C to 80 C.

Instruments — Chauvin Arnoux showed a reading device that attaches to a meter face and signals a relay when the meter needle passes. A light beamed on the scale face reflects onto a pair of photoelectric cells in a balanced bridge circuit. When the needle interrupts the beam, the bridge unbalances.

Component tester developed at the Centre National d'Etudes des Telecommunications and made by SECRE automatically measures up to 10 component parameters. Plug-in test circuits sequentially switch onto the component under test. Test rates run up to 1,200 transistors and 6,000 resistors and capacitors an hour.

Plug boards also program an automatic process chromatograph from Electronique et Mechanique d'Aquitaine. Binary circuits change



speed components tester developed in
SECRE



MIDGET oscilloscope by Ribet-Desjardins features 2-Mc passband

the program. Attenuations of the chromatograph peaks, for example, can be selected at seven levels ranging from 1 to 1,000. Each peak triggers the next step in the program.

The French Air Force Ballistics Lab is using a series of microwave barriers to photograph small missiles in flight. Each barrier is a pair of antennas. The gap between the antennas is one arm of an impedance bridge powered by a 3-cm klystron operating at 150 mw. When a passing projectile upsets bridge balance, it triggers a 0.1- μ sec flash.

Serel showed its small but fast 505 computer, costing \$30,000. It is programmed by plug-in cards, has a 1,024-word transluxor memory with read time of 5 μ sec for a 20-bit word.

Miniature oscilloscope by Ribet-Desjardins features a passband of 2 Mc and a sensitivity of 10 mv/division for a-c and 50 mv for d-c. Divisions on the 1.25-inch crt are 0.1 inch.

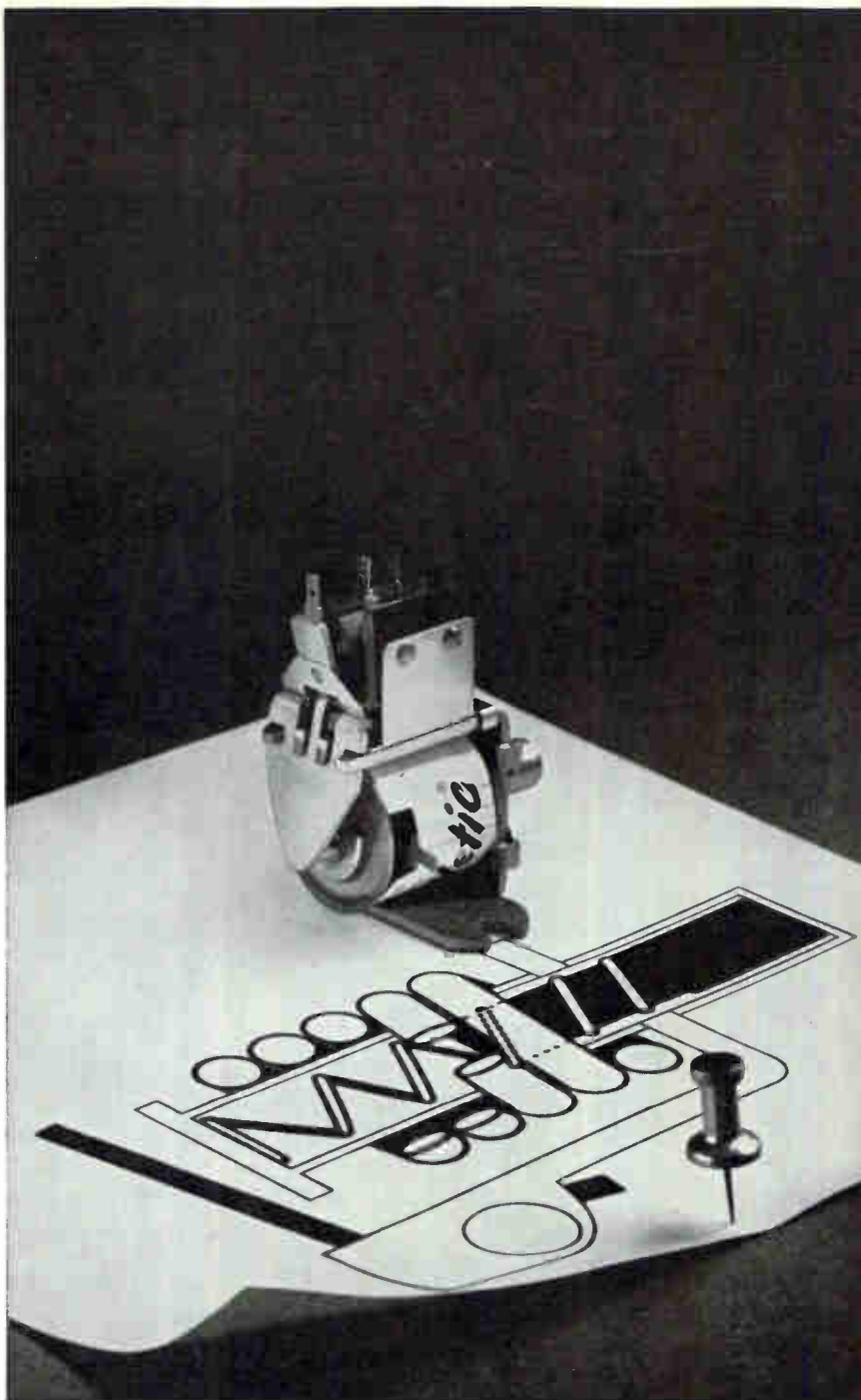

Time delay with fast recycling: that's what you get with Heinemann hydraulic-magnetic time-delay relays. Reset time is typically only 15% of the specified delay. At the low price of the Heinemann relays, such TD performance is hard to come by. □ You also get inherent freedom from excessive ambient temperature effect. (We don't use thermal actuation.) □ Another advantage: continuous-duty coils. Since the Heinemann relay coil can remain energized after actuation, you can often eliminate the load relay. Healthy contact rating helps. Up to 5 amp for the little Type B shown here. SPDT or DPDT switching, too. □ The Type B (and our entire TD relay line, including hermetically sealed and plug-in models) comes in a choice of 18 AC and DC voltages and 16 timings, from 1/4 second to 2 minutes. □ More information? Bulletin 5005 will give you detailed technical data.

HEINEMANN ELECTRIC COMPANY

2600 Brunswick Pike



Trenton, N. J. 08602

SA 2878

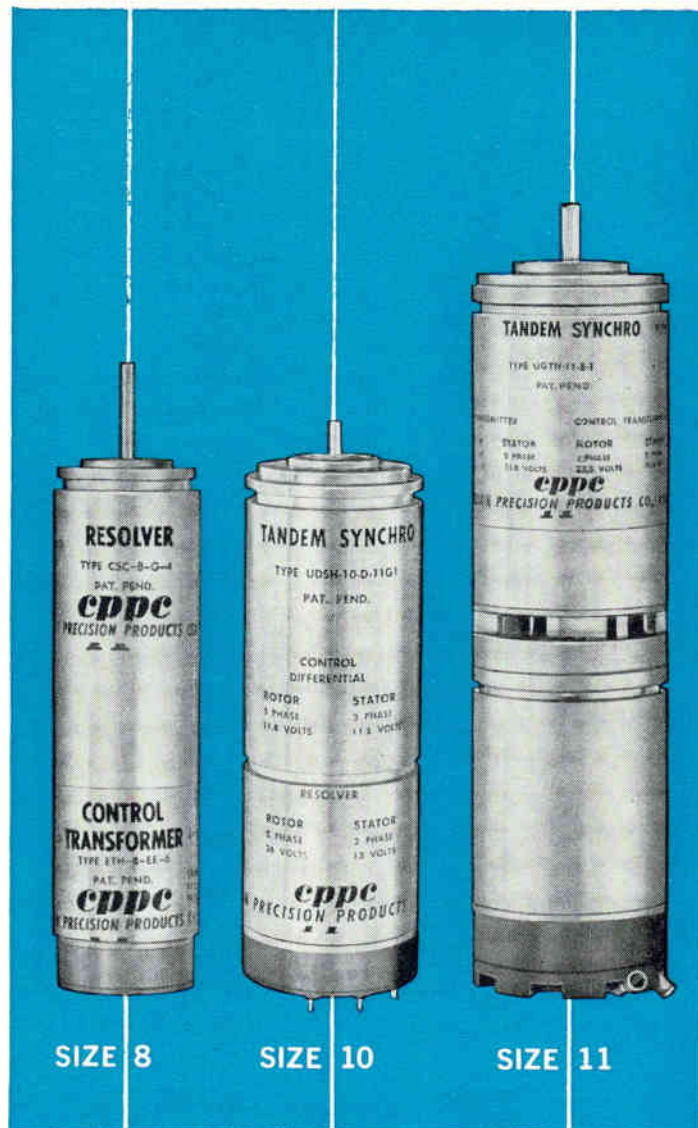

SIZE 8

SIZE 10

SIZE 11



TANDEM SYNCHROS

SAVE YOU SPACE, GEARING, ACCURACY, COST

Our tandem synchros offer two synchro functions (transmitter, control transformer, differential, resolver, etc.) in a single housing with a common shaft.

If the extra length of tandem synchros doesn't bother you, there are attractive advantages. For instance, a gear train may be entirely eliminated (and its accompanying backlash). Or, a simpler gear train may be possible. Thus there is likely to be a saving in cost.

Stainless steel housings give Clifton units the necessary rigidity to overcome vibration problems. We also use a unique

mechanical coupling device which has reduced coupling errors to one minute max.

Any two of our hundreds of differing electrical and mechanical characteristics are available in sizes 8, 10 or 11.

Lengths are: Size 8—2.900 inches, size 10—2.700 inches, size 11—3.900 inches.

For price and delivery, contact: Sales Dept., 5050 State Rd., Drexel Hill, Pa. Area 215 MADison 2-1000. TWX 215 623-6068— or our Representatives.

CLIFTON PRECISION PRODUCTS CO., INC.

Clifton Heights, Pa. • Colorado Springs, Colo.



Johnson: A Preview of His Policies

WASHINGTON—The U. S. space program should move ahead faster under President Johnson. That's the judgment of Chairman Clinton P. Anderson (D.-N. M.) of the Senate Space Committee. Johnson is the father of the space program, was the leader in forcing a decision on the ambitious Apollo moon program, and, Anderson says: "He knows more about American space aims and the present effort than anybody in government."

Officials expect additional emphasis on nuclear projects, especially the Rover rocket program. Johnson has urged development of rockets and advanced-stage reactors.

Equally, Johnson has intimate knowledge of the Communications Satellite Corp. and would communications. His Senate report following a communications satellite study laid the groundwork for the recent international agreement on space communications frequencies.

Johnson probably will lean more toward national security in his decision making on space, and less on civilian programs. He has great faith in Secretary of Defense McNamara, who will remain the No. 1 adviser in the Administration, ahead of Secretary of State Dean Rusk, who is emerging as a potentially more powerful man under Johnson than he was under President Kennedy.

Science Policy

Johnson organized the Senate to handle science on a narrow base to avoid the jurisdictional-political problems that cutting across agency and committee assignments presented. This would bode ill for the sweeping, interdepartmental approaches being mapped by Jerome B. Wiesner and the Federal Council on Science and Technology. What Johnson will do is make the program taut.

Johnson will make no policy changes in science. Wiesner and his successor, Donald F. Hornig, will stay on.

Johnson, with a tactical rather

than strategic approach, working problem by problem "without the deep intellectualism Kennedy had . . . without a sense of history" doesn't seek the same kind of scholarly backing for decisions President Kennedy sought.

Staunch SST Backer

Johnson drove Washington officials to undertake the supersonic transport project. Early this year arguments raged over whether the government should subsidize the SST program in view of its heavy commitments in other areas such as defense and space; whether or not we should have an SST at all, and if so, what sort of plane it should be.

Najeeb Halaby, head of the Federal Aviation Agency, had recommended that his plan for the SST program be reviewed by a high-level committee.

In short order this group made up its mind to go ahead with the proj-

ect, leaving the construction details to a design competition to be held among manufacturers later. Perhaps the key decision in which Johnson rode over his colleagues was the one in which he insisted the government finance 75 percent of the project (to be paid back later) and that work be started forthwith.

His First Test—Taxes

Johnson is dedicated to the Administration's tax cut program. A test of his leadership will come soon in the way he handles the Senate Finance Committee; should he get cooperation in the manner he had it as Senate majority leader three years ago, the bogged down tax cut legislation might well come out of the committee, and be ready for the Senate to debate by January.

Military spending will continue at its present pace. Johnson will send a budget to Congress in January much like the one being prepared by offi-

IN MEMORIAM

JOHN FITZGERALD KENNEDY

1917-1963

The death of President Kennedy has left us all shocked, stunned and grieved. Although ours is a publication devoted to technology, it is produced by men, and what man can let the events of the past week go by, remaining unmoved and unaffected?

One could dwell on the late President's interest in science and his appreciation of the importance of the engineering profession to the security and well-being for our country. Or one might emphasize his determination to make America's defenses second to none. That is, if one wanted to consider his impact on the technological community.

But in the final analysis, our loss cannot and should not be measured in these terms. As a leader, as a symbol, as a father—as a man—these are the standards by which the loss assumes that personal quality that beggars articulation.

The world mourns for him. But the world must go on. We pray that in the weeks and months ahead, the leaders of our nation and the world remember, especially, one of his last statements on the obligation facing men of his stature:

"We ask, therefore, that we may be worthy of our power and responsibility—that we may exercise our strength with wisdom and restraint."

cials now. As creator and one-time chairman of the Senate Preparedness Subcommittee, Johnson is inclined to listen carefully to the uniformed services and service chiefs as well as his diplomatic and strategic advisers.

He is a free trader and business should expect him to carry out the Kennedy Administration plans for tariff negotiations under the new trade law in Geneva next year.

English Firm Studies Tunnel-Diode Computer

LONDON—High-speed nanosecond computers using tunnel diodes are being developed by Elliott-Automation. A three-year research effort has resulted in breadboard logic and storage units. Elliott is asking the government Department of Scientific and Industrial Research for developmental assistance.

Basis of the system is use of a three-phase 50-Mc power supply to preserve signal directionality. Tapered strip lines interconnect the logic circuits, to eliminate stray cur-

rents induced in the signal paths.

For logic units, a Goto pair and an inverter configuration have been developed. Signal leads are formed on a multilayer printed-circuit. A ground plane associated with each layer keeps strip-line impedance constant. Delay-line storage units are now under design.

Ejected Radio Guides Search Planes to Crash

LONDON—Britain's supersonic aircraft will carry a flight recorder with a new twist. Ejected by excess g forces or contact with water or fire, it contains its own radio transmitter to guide search planes to the crash scene. The transmitter operates for 48 hours and can be heard by planes 50 miles away flying at 10,000 feet. The recorder, developed by Redifon, monitors 280 items a second, plus the pilot's speech. When ejected, it contains a complete monitored account of the last 15 minutes of the flight.

Computer Will Direct West London Traffic

LONDON—A \$1.2-million electronic system will be installed by 1965 to control road traffic over the western approaches to central London. Traffic flow will be measured by electromagnetic detectors set in the road. A computer will control traffic lights and signs indicating diversions or instructing drivers to make up more traffic lanes. Closed-circuit tv cameras will provide visual backup information.

Test Undersea Transponders As Positioning Devices

"SOUNDHOUSES" located underwater off Bermuda are being evaluated as positioning devices for civilian and military vessels. Developed by Edgerton, Germeshausen & Grier, they are essentially sonar transponders and can be triggered by a standard 12-kc recording depth sounder. The EG&G system uses conventional dry-cell batteries. The transponders have been operating at a depth of 300 meters for more than a year, but are built to operate at 6,000 meters. They weigh 200 pounds in air and are self-anchoring. A similar system is planned for project Mohole (p 17, Sept. 27).

MEETINGS AHEAD

DEFENSE ELECTRONICS SEMINAR, Defense Supply Association; Fort Jay, Governors Island, New York, Dec 3.

WIRE AND CABLE SYMPOSIUM, Army Electronics Labs; Berkeley-Carteret Hotel, Asbury Park, N. J., Dec. 4-6.

ULTRASONICS ENGINEERING SYMPOSIUM, IEEE-PTGUE; Marriott Motor Hotel, Washington, D. C., Dec. 4-6.

VEHICULAR COMMUNICATIONS NATIONAL CONFERENCE, IEEE-PTGVC; Adolphus Hotel, Dallas, Texas, Dec. 5-6.

RELIABILITY IN SPACE VEHICLES SEMINAR, IEEE-PTGR, ED, CP; Los Angeles, Calif., Dec. 6.

FALL URSI MEETING, IEEE Seattle Section, URSI, Boeing Scientific Research Laboratories; University of Washington, Seattle, Wash., Dec. 9-12.

FIRST MICROELECTRONICS CONFERENCE, EIA; Irvine Auditorium, University of Pennsylvania, Philadelphia, Penna., Dec. 10-11.

NON-LINEAR PROCESSES IN THE IONOSPHERE MEETING, NBS; Central Radio Propagation Laboratory, Boulder, Colo., Dec. 16-17.

AMERICAN ASSOCIATION FOR THE ADVANCEMENT OF SCIENCE MEETING, AAAS; Cleveland, Ohio, Dec. 26-30.

RELIABILITY-QUALITY CONTROL NATIONAL SYMPOSIUM, IEEE, ASQC, ASME, EIA; Statler Hilton Hotel, Washington, D. C., Jan. 7-9.

INTEGRATED CIRCUITS SEMINAR, IEEE New York Chapter; Stevens Institute of Technology, Hoboken, New Jersey, Jan. 15.

ANTENNA RESEARCH APPLICATIONS FORUM, Midwest Electronics Research Center; University of Illinois, Urbana, Ill., Jan. 27-30.

INSTRUMENTATION SYMPOSIUM, ISA North Central Area; New Sheraton-Ritz Hotel, Minneapolis, Minn., Jan. 30-31.

ADVANCE REPORT

REGION 6 ANNUAL CONFERENCE, IEEE-ISA; Salt Lake City, Utah, April 29-May 1, 1964; Jan. 15 is deadline for submitting 200-word abstracts to Prof. Clayton Clark, Electrical Engineering Department, Utah State University, Logan, Utah. Some electronics topics include lasers, masers, radiometry, space measurements, information theory and decoding, automatic controls, semiconductor circuitry, military electronics, satellite relays, medical electronics.

Inverter May Extend Fluorescent Light Use

GE HAS DEVELOPED a 4-ounce inverter-ballast the size of a cigaret pack that could bring fluorescent light to the interiors of cars, trucks and pleasure boats, where it is now impractical. The device consists of a power transistor and five other components, including a high-frequency transformer (p 30, July 19). It operates fluorescent lamps at frequencies ranging from 7 to 20 kc, instead of 60 cps, and over a wide range of voltages, including those of most transportation-type batteries. Further tests will be held before the device is sold commercially.

Pershing Looks Good in Tests

FORT WINGATE, N. M.—The Army is winding up a series of field tests of its 100- to 400-mile range Pershing tactical missile, prior to deployment in Europe early next year, and the Far East later. Bendix Pioneer representatives say no in-flight failures have been reported in the guidance system, a follow-on of Redstone's.

Army officials expressed satisfaction with results of one field test witnessed last week by the press. "Nothing stands in the way of operational capability," a spokesman said. The missile was handled and fired entirely by Army combat troops from rough terrain on this Army base.

Martin has just signed a fixed-price contract with the Army for production of the Pershing, successor to the larger, costlier Redstone. The contract is described as the first fixed-price agreement for a "missile of this capacity." Modifications under study may make the Pershing smaller, more maneuverable and more accurate. Cost of Pershing is less than the \$900,000 for a Redstone, officials said, and the program to date has \$500 million.

West Germany has ordered two Pershing battalions, each outfitted with four firing units and communications equipment. The Germans would like to have two more. Atomic warheads would be under U. S. control.

Huge Transponder Buys Planned by Airlines

WASHINGTON — Airlines plan to equip virtually all their aircraft with improved radar beacon transponders by 1966, bringing their investment in beacon equipment to about \$25 million. Their decision is in line with the FAA's plan to use transponders—with altitude and positive identification capabilities—as the basic element of a modernized air traffic control system.

The transponders now in use employ 64 codes, but the new ones will have 4,096 codes so that planes can give more specific identity information. Side-lobe suppression circuitry will minimize unwanted signal responses. Adapter units, for altitude reports, will be installed later.

Signal Processor Contract Awarded for \$3 Million

CUTLER-HAMMER will develop the signal processor for the earth-satellite tracking system being built by Bendix for the Air Force. After detection and parameter estimation,

the processor will operate on the signals derived from the multiple receivers of the phased array, transforming them from analog to digital data for use in a computer. Bendix has given Cutler-Hammer a \$3-million subcontract for the processor, scheduled for installation next May at Eglin AFB, Fla.

U.S. Set to Launch Biggest Booster Yet

MOST POWERFUL Saturn I, scheduled for launch about Dec. 11, will carry a payload almost three times that of the largest payload yet orbited by the Soviet Union. The booster will put a 38,000-lb. dummy payload carrying C-band telemetry beacon equipment into a 400-mile apogee, 160-mile perigee earth orbit. The vehicle will have no active guidance, and a control system that only meets attitude control and engine cut-off requirements. The launch will be accompanied by the biggest test of tracking equipment to date—using facilities of NASA, DOD and the Smithsonian Astrophysical Observatory.

IN BRIEF

COMPACT, WIDEBAND laser modulator will be developed for the Air Force by Sylvania (p 28, Feb. 22). The \$82,960 contract also calls for the development of a modulation bandwidth of more than 1 Gc. The present device will be reduced in size from 40 inches to "a few inches."

BIG ROCK POINT Nuclear Plant, Charlevoix, Mich., has achieved 34 percent thermal efficiency—meeting the 34-38 percent of conventionally powered generating stations, says GE. The reactor uses a computer in its control system.

NAVY is making its first use of tropo scatter gear at a Rota, Spain, installation. Equipment was designed by Radio Engineering Laboratories to meet communications needs of the Sixth and Atlantic fleet based in the Atlantic and Mediterranean areas.

VHF-UHF-TV production reached 732,650 sets during the January-September period this year compared to 418,966 during the same period last year, says EIA.

TWO-WAVELENGTH laser, to perform interferometric studies of plasma and examine various shock phenomena, is being developed for the Army by Kollsman. The device will produce basically square, 20 microsecond pulses with high beam uniformity.

FIRST all-digital systems operation computer in the electric power industry will be delivered next year by Westinghouse to the Kentucky Utilities Co. The Prodac 510 operates on an on-line shared time basis.

INDIA will buy \$42-million in communications equipment through a World Bank loan. Included will be a new phone switching plant supplied by ITT's Belgian subsidiary—successful bidder over Nippon Electric and Sweden's L. N. Ericsson.

U. S. NATIONAL BANK, Omaha, is using idle computer time to give doctors a centralized accounting system.

Code of Ethics For Contractors May Tighten Up

Standards of ethics approaching those for government employees are being urged for defense-contractor personnel. The House Government Operations Committee recommends the tightening up, to avoid conflicts of interest. Senior defense procurement and contractor officials—both military and civilian—would have to disclose financial interests.

Last summer, the Pentagon drew up a code of conduct for contractors aimed at preventing organizational conflicts of interest. This would be tightened. The Pentagon would have to maintain a central register of contracts that limit participation in hardware development or where a firm with a study contract has access to proprietary data of other firms. Contractors with access to such data would have to give contracting officers copies of agreements reached with the owners of the data, and steps taken to protect it.

FCC Backs Tax Moratorium for All-Channel Tv

FCC has a hole card if any tv manufacturers are tempted to stockpile vhf-only sets in the first quarter of 1964. FCC backs a proposal for a temporary moratorium on the excise tax on all-channel tv sets. The idea now has little chance of congressional approval. But any signs of stockpiling vhf sets to sell after the April 30 deadline, when manufacture of all-channel sets will be mandatory, will strengthen FCC's hand in seeking the moratorium. There's no doubt now that FCC is determined to make all-channel tv succeed.

AEC-NASA Man Attacks White House Scientist

Congressional and federal agency critics of Jerome B. Wiesner's White House science establishment now have an eager spokesman. He is Philip Abelson, of Carnegie Institute's geophysical laboratory. A maverick excluded from top government science circles, the outspoken Abelson calls Wiesner's staff undistinguished. He adds that Wiesner has garnered more power than any other scientist, and has few constructive results to show for it. White House aides fear such criticism could build into a counterattack, uniting congressmen and powerful agencies like the Atomic Energy Commission and the National Aeronautics & Space Administration against Wiesner's brand of centralized coordination of U. S. science and technology policy. Abelson is an adviser to both AEC and NASA.

Meany Didn't Declare War On Automation

There's no real shift in labor policy toward automation, despite AFL-CIO President George Meany's recent flat statement that there is "no element of blessing in it." The AFL-CIO convention went right ahead and passed a reaffirmation of labor's traditional view: that automation has a role to play in eliminating poverty, but workers shouldn't bear all the burdens of change.

Here's Why GAO Opposes Leasing

Army's White Sands Missile Range is under fire by the General Accounting Office for leasing, rather than buying, electronic data-processing equipment. "Unnecessary costs" of \$1.3 million resulted over a 32-month period from the leasing of two 704 computers which IBM had offered to sell at a discount. GAO repeated its recommendation for a central government procurement agency for data-processing equipment.

NEWS

Two new PTC thermistors extend your control parameters

Look at the curves for our new positive temperature coefficient thermistor compositions D and E and you'll recognize that you now have new and useful resistance/temperature characteristics at your disposal.

These new materials, together with our previously available A and B compositions, give you this wide range of switchpoints:

Composition	Switch Temp.	Maximum Working Temp.
D	-55 C	110 C
A	0 C	135 C
E	60 C	135 C
B	90 C	135 C

You can read the right-hand column as the maximum temperature for working characteristics or as maximum continuous operating temperature, whichever is pertinent to your circuit.

Here's how we match our PTC compositions and applications: A—semiconductor device compensation, current limiting; B—current limiting, li-

quid-level sensing, overheat sensors; D—low-temperature compensation of silicon transistors and other semiconductor devices; E—liquid-level sensing, overheat sensing, current limiting.

You'll find data with the curves on the standard CARBORUNDUM® PTC thermistors available in each composition. You can get engineering quantities of these parts off our shelves. We'll be happy to quote on production quantities.

We can also give you fast delivery on engineering quantities of special resistance values, in sizes from .1" to .7" in diameter.

For complete data sheets or to order test quantities of any or all of our four PTC thermistors, please write Dept. E11, Electronics Division, The Carborundum Company, Niagara Falls, N. Y.

CARBORUNDUM

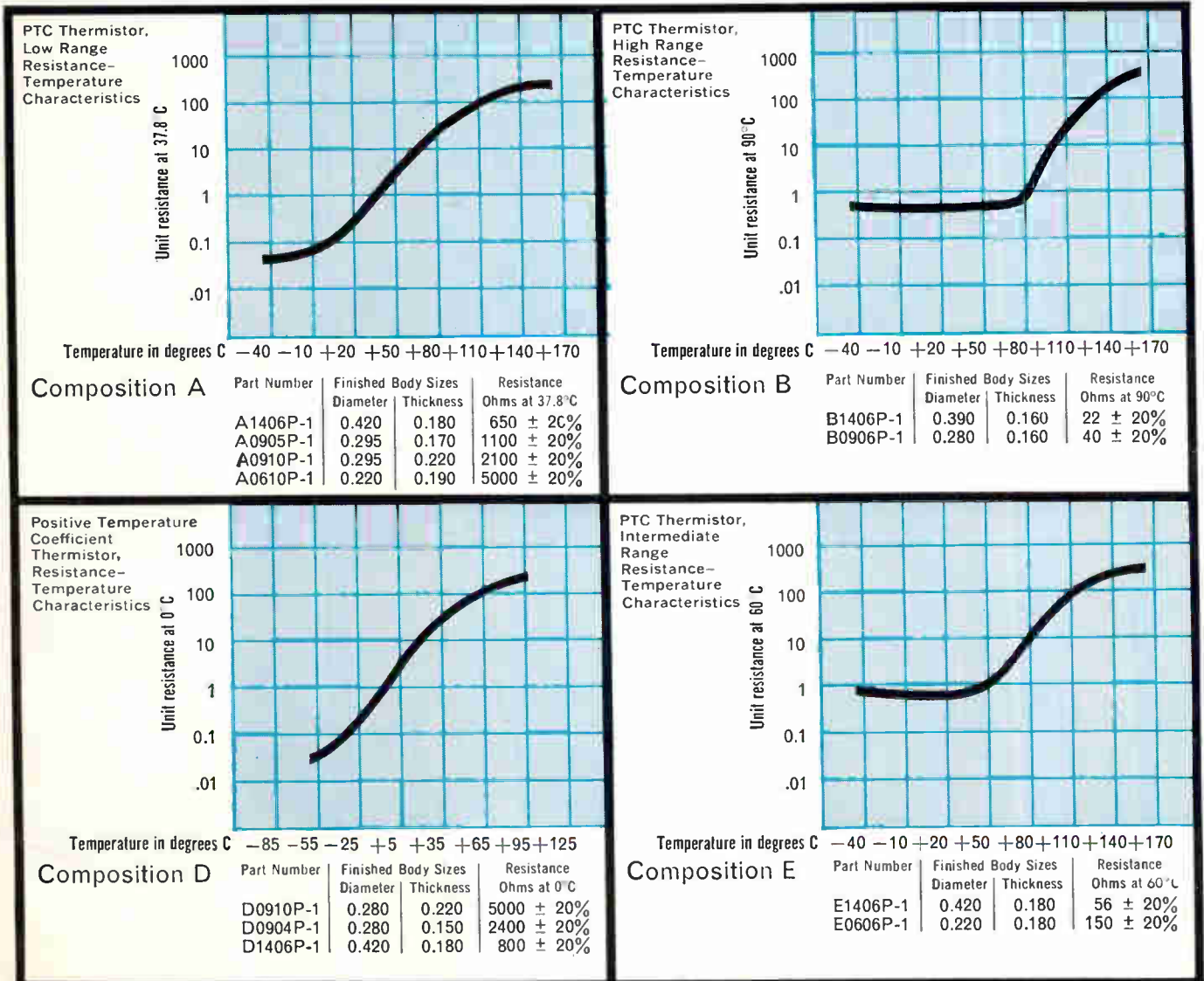

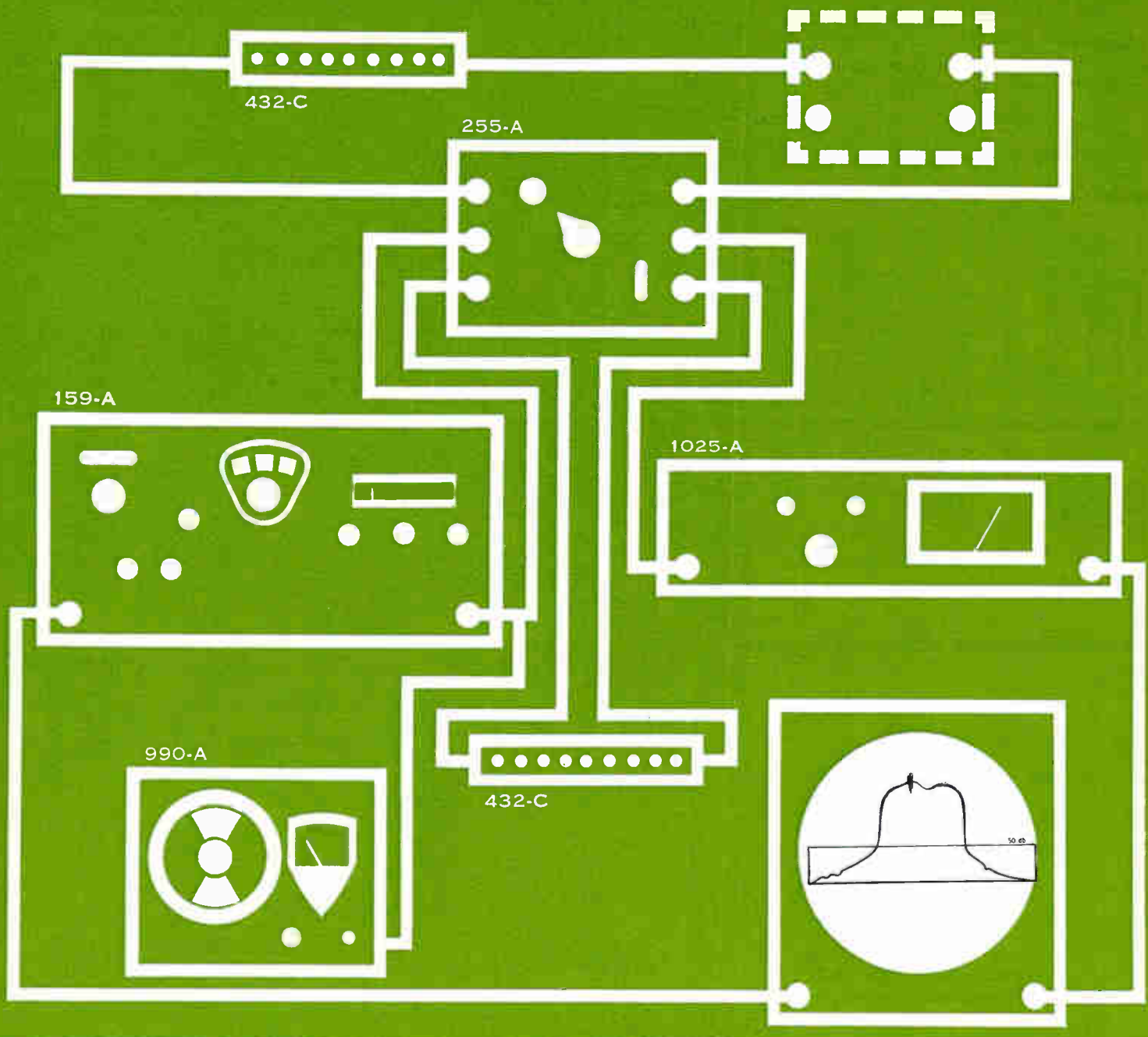

Wide Swept, Marked, Logged... by **KAY**

A broad amplifier with critical roll-off scanned over 300 mc and marked in frequency by the 159-A and 990-A, on the log amplitude display of the 1025-A with calibrated level line set by the 432-C, switched in by the 255-A.

159-A Sweeping Oscillator

1 mc to 300 mc
full 300 mc sweep

Price: \$795.00

990-A CW Oscillator

4.5 to 220 mc
1.0V rms, AGC'd

Price: \$373.00

1025-A Log Amplifier

200 kc to 220 mc
80 db Dynamic Range

Price: \$795.00

432-C Attenuator

DC to 500 mc
0 to 101 db in 1-db steps

Price: \$110.00

Write for complete catalog information

KAY
ELECTRIC COMPANY

Maple Ave, Pine Brook, Morris County, New Jersey

Dept. E-11 • CApital 6-4000

255-A Coaxial Electronic Switch

DC to 500 mc
70 db "off" at 200 mc

Price: \$295.00

FULL serial adder using conventional and-or-invert elements (A), serial full adder with three majority gates and one inverter (B), and three-input majority gate using and-or diode logic (C)—Fig. 1

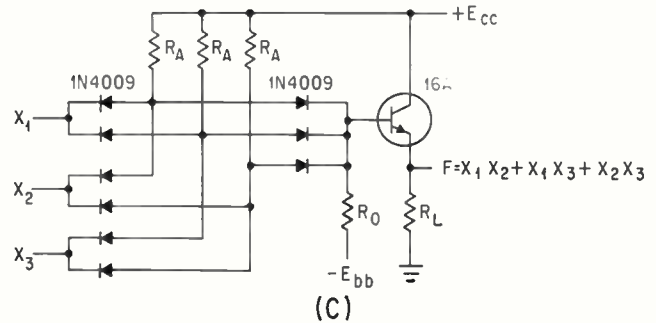
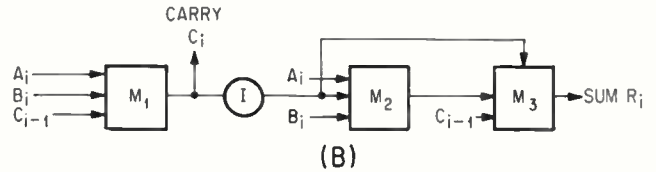
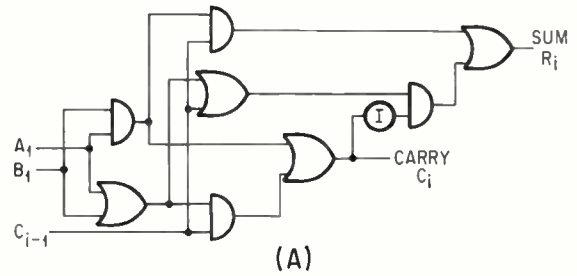

How to Achieve MAJORITY and THRESHOLD LOGIC with Semiconductors

Synthesis of threshold logic has been the object of considerable recent research. Here are some circuit approaches that are accelerating logic design

By W. A. SAUER, Application Engineering, Semiconductor Products Dept., General Electric Company, Syracuse, N. Y

CONSIDERABLE attention has recently been given to synthesis of threshold logic. Much of the work performed has been slanted towards logical synthesis of Boolean functions, while less attention has been directed towards circuit synthesis of the basic threshold gate. Majority logic, which may be regarded as a less general form of threshold logic, has been widely discussed from a reliability viewpoint. Here are some of the circuit approaches that have been suggested as a possible means of realization.

Majority Gate—A majority gate may be considered as a logic element with a single output and an odd number of n inputs. When less than a majority of the

inputs are 1, the output is 0. The number of inputs is limited to odd numbers to ensure that there will never be a situation where there are an equal number of inputs at the 1 and 0 levels.

If an M-gate (Majority-gate) has three inputs X_1 , X_2 , and X_3 , then the output may be written as

$$M(X_1, X_2, X_3) = X_1 X_2 + X_1 X_3 + X_2 X_3 \quad (1)$$

where any two or more inputs at the 1 level will cause M to have the value 1.

It is possible to consider the M gate as a logic element just as AND, OR, INVERT, NOR and NAND gates are considered logic elements. Considering the Boolean functions for a serial binary adder synthe-

STILL MORE RELIABILITY

As electronic equipment grows more sophisticated, the need for reliability goes up. In a computer, where the failure of a simple gate can cause considerable unit down time, a more reliable circuit or element is particularly desirable. These circuits enhance reliability through redundancy techniques. Moreover, they take advantage of the characteristics of semiconductor elements like the tunnel diode to increase flexibility

sized in Fig. 1A with AND, OR, and INVERT elements, this particular scheme requires four AND gates, four OR gates and one INVERT gate, making a total of nine gates. It is possible to realize this circuit in other ways but this is one of the simplest, unless special rather than general gates are used.

The carry, C_i , and the result, R_i , may also be generated using only M and INVERT gates as shown in Fig. 1B. This arrangement requires only three M gates and one INVERT gate to form both functions R_i and C_i or a total of four circuits. If the M gate is less complicated or only slightly more complicated than the AND and OR gates of Fig. 1A, an appreciable savings in circuits may be realized.

The preceding does not prove that a digital machine composed of three-input M gates and INVERT gates will require less than fifty-percent of the circuits required with more conventional gates. It merely illustrates that the M gate approach is simpler. However, there are functions that are not simpler to realize with M gates; it is also true that both the carry and result functions are simpler with an M gate. Hence, there are at least two functions of three variables which are simpler. Therefore, it is suggested that the M gate may be a useful addition to a set of general logic elements.

Most conventional logic elements use diode logic followed by an amplifier. Thus, an AND circuit might use a diode-logic AND connection followed by an amplifier in the common-collector configuration, while the NAND circuit uses essentially the same diode-logic with the amplifier in a common-emitter configuration. This approach can also be used to generate an M gate. In Figure 1C, the diode-resistor combination forms Eq. 1 and the emitter-follower provides current-gain without inversion. This circuit closely resembles some of the AND-OR logic elements used in Ballistics Missiles Early Warning System (BMEWS) some years ago.

Threshold Elements—M-gates can be considered a special case of the more general class of threshold elements. Figure 2A illustrates the elementary notions behind threshold elements. Each of the inputs $X_1 \dots X_n$ represent the usual binary variables with the possible 0 and 1. The constants $a_1, a_2 \dots a_n$ are weights assigned to the input. Thus, for $a_i > a_j$ the variable X_i will have a greater influence when $X_i = 1$ than X_j when $X_j = 1$. One way of expressing this is to consider the algebraic expression for any combination, a_i , of the set of inputs $X_1, X_2 \dots X_n$

$$f(\alpha_i) = \sum_{i=1}^n a_i X_i \quad (2)$$

The value of f in Eq. 2 can be less than, equal to, or greater than the threshold value, T . Excluding, for convenience only, the possibility of equality, the Boolean function, $F(a_i)$ can be written

$$F(\alpha_i) = \begin{cases} 0 & \text{if } f(\alpha_i) < T \\ 1 & \text{if } f(\alpha_i) > T \end{cases} \quad (3)$$

The M gate simply has $a_1 = a_2 = \dots = a_n$. To prevent $f = T$ under these conditions, the requirement of an odd number of inputs is added.

The nonlinear nature of the base-emitter diode in a transistor permits thinking of this as a threshold. Depending on the exact type of device, the temperature, current levels, etc, the transistor may be virtually off up to a base-emitter voltage of +0.5 volt and on at a base-emitter voltage of +0.7 volt. An arrangement using a resistor-summer at the input and a collector-clamped common-emitter amplifier for gain is shown in Fig. 2B. Hence, the output is inverted.

This circuit has virtually no margin for the usual tolerances associated with ordinary resistors and voltage sources. Assuming 0 percent tolerance on power supplies and resistors, the transistor off at +0.45 volt base-to-emitter, the transistor on at +0.7 volt base-to-emitter, and a minimum h_{FE} of 30, this circuit has a fan-out of three. The cross-hatched lines on the graph (Fig. 2C) indicate the allowable choices of resistances and the permissible variation in value for any given choice.

To improve performance, B. H. Rutter, of the General Electric Electronics Laboratory, has worked on the circuit shown in Fig. 3. Here, a tunnel diode is used to enhance the thresholding effect. This circuit was built with up to fifty-one inputs, a substantial improvement over the circuit of Fig. 2C.

Logical Synthesis—The question of logic synthesis utilizing these elements becomes serious. The difficulty of using what is now considered an unconventional logic element could conceivably be so large that the logic design effort required would be impractical. Fortunately, a great deal of attention has been given to this problem and although various approaches are not perfect in the sense that they always give a minimum form, or can easily handle 100 variables, some are practical within their limitations and constraints.

Shelley Akers of the Electronics Laboratory has developed a method of synthesis for three-input majority gates as reported in the company's TIS series papers. This approach is based on the concept of logically passive functions, developed as a synthesis tool. Here, an essentially logically passive function may be synthesized without the use of inverters. A function such as

$$F = (A\bar{B} + \bar{A}B)\bar{C} + (AB + \bar{A}\bar{B})C \quad (4)$$

for example, can be synthesized without inverters provided the variables $A, \bar{A}, B, \bar{B}, C,$ and \bar{C} are all available. Assume F is logically passive with respect to the extended basis $b(A, B, C, \bar{A}, \bar{B}, \bar{C})$ in designation form. That is, determine by elimination pairs

those variables that must be present explicitly in any Boolean expression of the function. However, this basis is unordered and constraints are treated normally; that is, don't-care conditions are omitted as a row of the truth table or a column of the designation number.

Once the function has been made logically passive with respect to its basis or truth table (table of combinations in Caldwell's term), the next step requires reducing the number or rows of the table (or columns of the basis) where the information is redundant. Use is made of the fact that, for any combination (a_i) of inputs (X_1, X_2, X_3) if a_i implies a_j , then $F(a_i)$ implies $F(a_j)$ if the function is logically passive. Thus, if a_i implies a_j and $F(a_j) = 0$, then combination a_i is redundant and may be removed since $F(a_i)$ must be zero if the function is logically passive. If, on the other hand, $F(a_i) = 1$, then the a_j combination is redundant and may be removed since $F(a_j)$ must be unity if F is logically passive. Thus, the method has a means for reducing and simplifying intermediate results.

By making use of the following property of M gates, namely,

$$M(A, B, C) = \bar{M}(\bar{A}, \bar{B}, \bar{C}) \quad (5)$$

the resulting table is studied to determine if this property is present. If it is not, then the appropriate constant, either 1 or 0 is added to the extended basis. The function is now self-dual, that is, it satisfies Eq. 5. Since it is also a logically passive function it can be classified as a logically passive self dual. This is accomplished simply by comparing those rows of the table (or columns of the basis) where F has the same value. There must be at least one variable that has the same value as the function F . If there isn't any such variable, the constant is added to provide this condition.

When the function has been made logically passive self dual, the resultant table is unitized by complementing each row of the table (or column of the basis) where the function has the value of 0. This is again justified by Eq. 5.

Further simplification is made as before and the reduced, unitized table is ready to be synthesized with M gates. Several rules are given for the selection of feasible M gates that will enable reductions in the required variables.

The whole process does not involve techniques that could not be easily handled by a moderately competent logic designer. A clever designer can implement the technique by intuition with little practice. The technique does not guarantee a minimum synthesis although many alternatives are usually generated in the process so that some choice may be made.

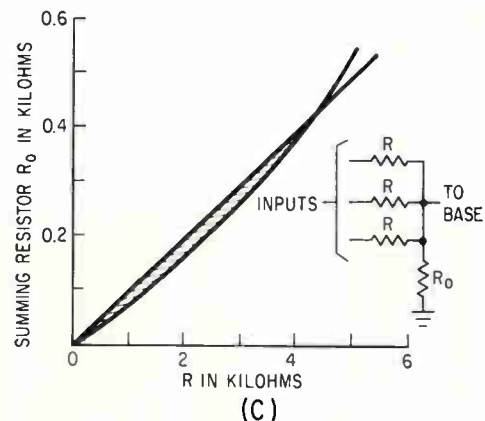
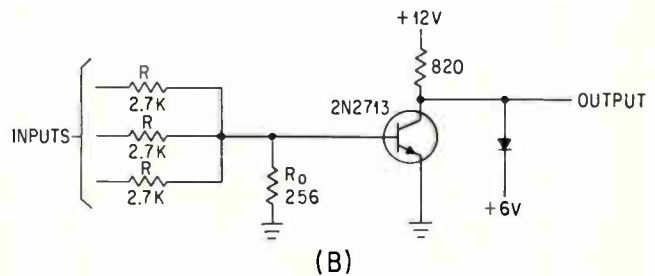
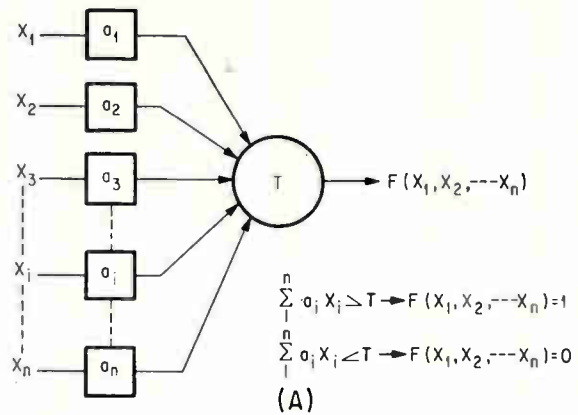

GENERAL threshold element (A), base-emitter thresholding with three inputs and fan-out of three (B), and graph showing input resistor weighing (C)—Fig. 2

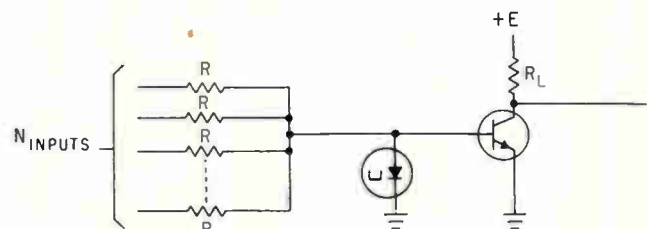

MAJORITY logic gate with tunnel-diode threshold—Fig. 3.

BIBLIOGRAPHY

- D. A. Sutton, "Majority Logic Circuit Design and Evaluation" Third Quarterly Report—Circuit Reliability Program, Vol 2, Internal Paper R61ELS122, General Electric Co.
- B. H. Rutter, "Gate Design for Self-Organizing Machines", Internal Paper R62ELS70, General Electric Co.
- S. B. Akers, "A Truth Table Method for the Synthesis of Combinational Logic", *IRE Trans. on Electronic Computers*, EC-10, No. 10, Dec. 1961.

- S. B. Akers and T. C. Robbins, "Logical Design with Three-Input Majority Gates," *Computer Design*, Parts I, II, III and IV, Mar., April, May and June, 1963, V2, Nos. 3, 4, 5 and 6.
- C. L. Coates and F. M. Lewis, II, "Linearly Separable Switching Functions", Internal Paper 61RL2764E, General Electric Co.
- S. B. Akers, "Threshold Logic and Two-Person, Zero-Sum Games", Internal Paper R62ELS29, General Electric Co.
- R. S. Ledley, *Digital Computer and Control Engineering*, McGraw-Hill Pub Co, New York, 1960.

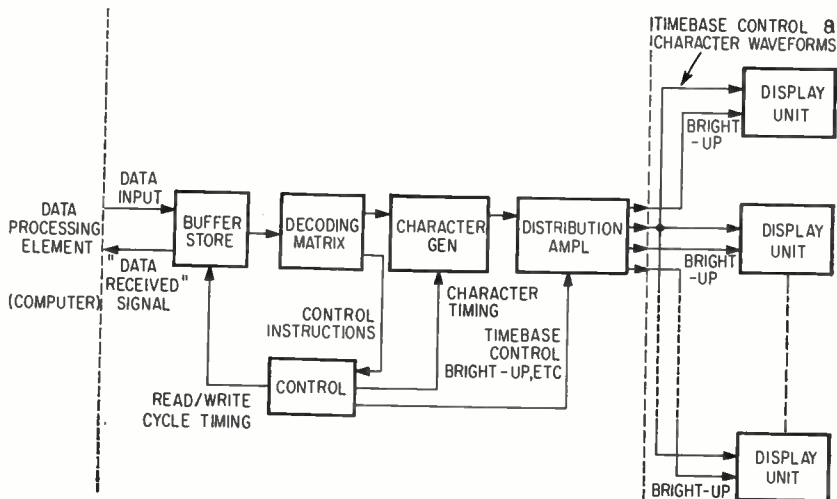

CHARACTER WAVEFORM generator and system control is in central equipment. Display units—monitors—are kept as simple as possible—Fig. 1

FASTER DATA DISPLAY

As data display systems are asked to perform more and more functions they are inevitably becoming more and more sophisticated. In military command and control situations, for example, so much data can be generated by computer processing that the selection of what data to display is now said to be more of a problem than data collection.

The same type of problem is occurring in industrial plants, where computers are being asked to monitor more and more processes. Here we present one British answer as to what to do about it

Data Display System Works in

Alphanumeric and other symbols are decoded from digital signals

PROCESS MONITORING system writes alpha-numeric characters on crt in simple display unit. Up to 12 different messages can be shown on separate monitors



WHEN ELECTRONIC data processors are used for on-line process monitoring, they often generate data faster than conventional readout or display devices can follow. Where human operators must react quickly to new data, the delay in display can be serious. But all-electronic systems using crts as readout can reduce display delays to a minimum, and one such display system is already installed in a British steel rolling mill and another is to be used in a nuclear power station.

The display system, Fig. 1, consists of a central buffer store and a high-speed character generator that can feed out 12 completely different messages for separate display. The data to be displayed, together with the display addresses, are first assembled in the buffer store. Information in the buffer store continues to be processed until changed by the computer.

Data in the store is in 6-bit words, one of which is read out every 20 μ sec. The data is fed to an electronic character generator which produces waveforms to write alphanumeric symbols on the crt output display.

The picture on the crt is a series of horizontal lines of characters, which may form a message or a tabular display. Each of 32 lines

STORE CYCLE control circuits (A) and timing diagram (B). During the 20 μ sec required to write a symbol, store readout is accomplished and data are updated—Fig. 2

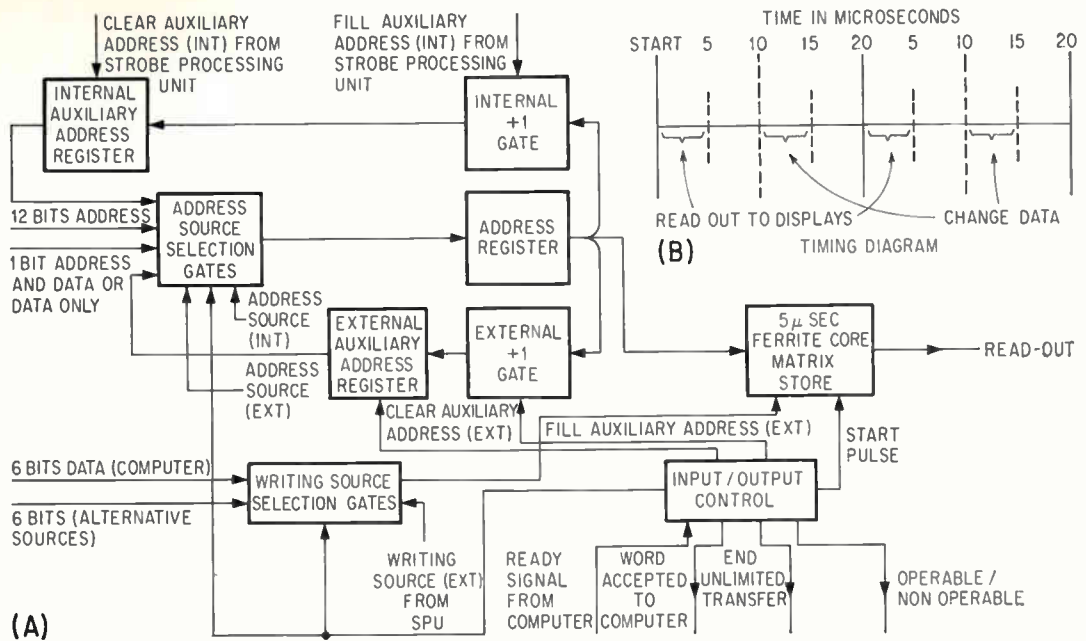

Microseconds

By F. W. KIME and A. HARTLEY-SMITH
Marconi's Wireless Telegraph Co., Ltd., Chelmsford, Essex, England

and written on cathode-ray tube monitors at 50,000 characters per second

can contain up to 70 characters.

Buffer Store—System storage capacity is governed by the characteristics of the display tube and writing time. To obtain a flicker-free presentation, even with a crt having considerable persistence, the repetition-rate must be 10 to 12 times per second. Thus, with a character writing time of 20 μ sec (50,000 characters per second), from 4,000 to 5,000 characters can be held in the buffer store.

The ferrite store therefore has 4,096 8-bit words; 6 bits describe the character or control instruction, 1 bit gives internal parity check, and 1 bit provides a strobing indicator when manual up-dating is required. The ferrite core driving circuits, Fig. 2A, use the conventional coincident current techniques and store read-out cycle time is 5 μ sec. The display read-write cycle is interleaved with the data input cycle, Fig. 2B. For the first 5 μ sec

of the 20 μ sec character writing period, the store is addressed by the internal cycling counter, which moves 1 count every 20 μ sec and runs up to a total of 4,096 (12 binary units). The data stored in this address is routed to the stacisor, where it is held for the full 20 μ sec period to instruct the character generator and cause a symbol to be written on one of the crts.

During the next 5- μ sec period the store is quiescent, after which it is addressed for 5- μ sec by a different address counter. The contents of this counter can be set to any address by the instructions from the external data source. In subsequent cycles it will clock on by one count each time unless it is reset to a new address by the external device. In this period the store accepts new data coming into the system.

The time from 15 to 20 μ sec is again quiescent so far as the store is concerned and the cycle then repeats. Thus incoming data can be

accepted at a high rate without interfering with the display output processes.

Display Control—Instructions to operate the timing of the display main time base, horizontal shift decoder and display bright-up selection are all stored as six-bit words along with the data.

At the end of each line on a display an instruction causes the main time base to be terminated; it also signifies that the next three codes are to be treated as control instructions, as shown in the table.

The six bits in the first instruction are decoded to determine which of the possible 64 lines on the displays will be shown next. In the following two instructions each bit corresponds to a display position and in each of the 12 possibilities a "1" signal indicates which display crt is to receive brightening pulses.

Thus one line on one display can be selected. The first instruction is also used to reset to normal the size of the character to be printed in the next line.

These control instructions also start to delay units which then inhibit the store cycling process until the display timebase has completed its flyback and has established a

DISPLAY CONTROL INSTRUCTION SEQUENCE IN BUFFER STORE

ADDRESS LOCATIONS					
n	n+1	n+2	n+3	n+4 ETC	n+x AS REQ'D
END OF LINE	LINE NUMBER	DISPLAY	DISPLAY	CHARACTER	CHARACTER
TIMEBASE	(1 OF 64)	ADDRESS	ADDRESS	CODES	SIZE
6 BIT CODE	6 BIT CODE	1 TO 6	7 TO 12 INC	6 BIT CODE	6 BIT CODE

linear sweep for the following run-down. After this the store cycle is released and the data in the next address is treated as a character code.

Logical Elements—The majority of the control circuits are digital and are based on a logical design employing transistor-diode elements known as "R units". These are fully compatible logic elements and, depending upon the polarity conventions adopted for the inputs and outputs, can perform the logical operations OR, AND, NOT, NOR, and NAND. Basic R-units are combined to give binary counters, bistables, registers, half adders etc. and are supported by other compatible specialized circuits for driving coaxial cables, operating signal lamps, delay generation and so forth. A circuit for a three-input unit is shown in Fig. 3.

Character Generator—The character generator consists of X and Y integrators that convert digital instructions from the character matrices into analog waveforms. These waveforms then trace out a character on a crt.

In integrator operation, Fig. 4A, capacitor C can be connected to either of two constant current sources through switches controlled

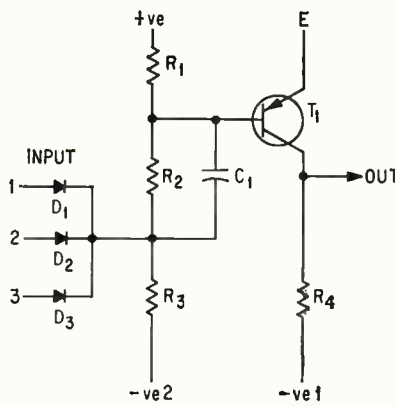

BASIC LOGIC element used in decoding circuits—Fig. 3

by the X_{+ve} and X_{-ve} instructions respectively. Current flow causes voltage build-up across the capacitor, which is stored when the source is disconnected, producing waveforms as shown in Fig. 4B. First, the voltage across the capacitor is reduced to zero by the transistor clamping circuit, which effectively short circuits the capacitor. During this clamping time the spot on the tube face is moved to the next character position. Similar integrators are used for X and for Y movements. Changing the size of the capacitor changes the size of character produced.

If the X and Y channels have identical gains the system can pro-

duce only horizontal, vertical or diagonal lines. To write the letter V and certain other symbols, the X integrator has charging currents that can be varied in the ratio 1.2 to 1. This allows beam movement at an angle of $22\frac{1}{2}$ degrees, thereby allowing a straight sided V or W, instead of the jagged V shown at the top of Fig. 4D.

The 20 μ sec writing operation is broken down as follows: the first two μ sec are for clamping; during the following two μ sec the spot is moved from its central position to the start point; the remaining 16 are the writing period. Any geometric shape or alphanumeric symbol that can be traced in 16 steps can be produced.

Display—One central equipment can feed up to twelve separate displays. Since the character generator is part of the central equipment, the display units are simple and inexpensive. Display crts have an $8\frac{1}{2}$ inch diagonal and use electromagnetic focus and a dual deflection coil system. Display units also contain slow line time base and horizontal shift decoders, bright-up amplifier and power supplies, as indicated in Fig. 5.

To reproduce the characters accurately and also move to the next position in a total of 20 microsec-

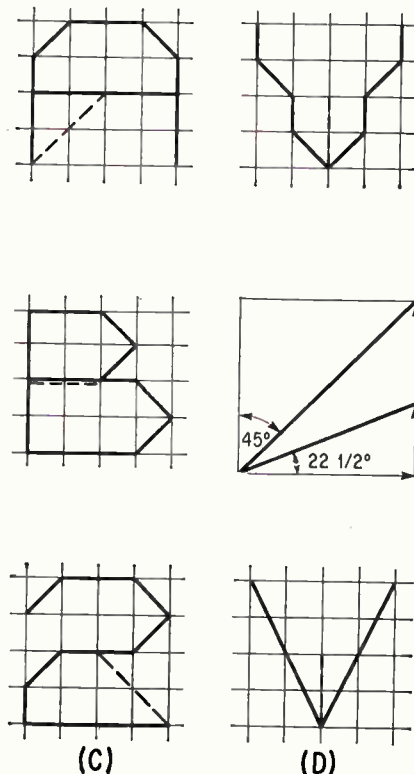
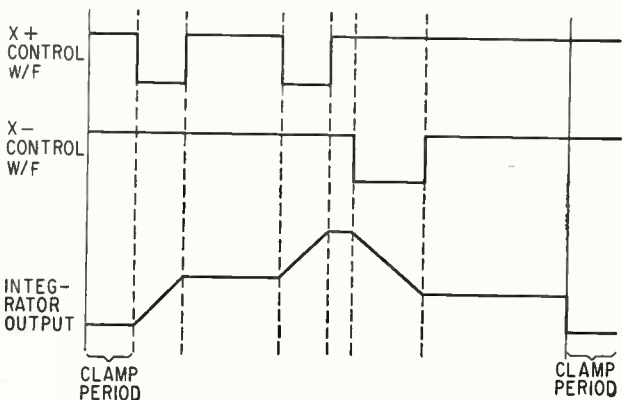
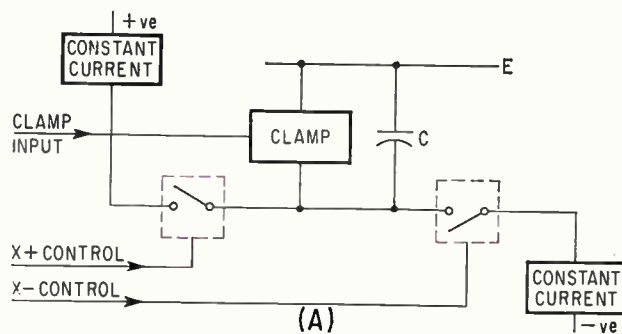

CHARGING a capacitor at constant rate from positive and negative sources (A) generates character writing waveforms (B) to produce written symbols (C). Changing the gain of one of the waveform amplifiers allows the jagged V at top of (D) to be written as straight sided V as at bottom of (D)—Fig. 4

onds requires a wide bandwidth deflection system. But to move the beam from one side of the tube to the other with such a system would require an uneconomic amount of current, while an economic current would mean low bandwidth and low speed writing. Thus a two coil deflection system is used, one with wide bandwidth for writing and one with low bandwidth for positioning, as shown in Fig. 5.

Input to the the *X* main amplifier is a slow sawtooth of sufficient amplitude to move the spot across the tube at a constant rate; input to the *X* auxiliary amplifier is a high speed sawtooth of duration equal to that of one character. The high speed sawtooth has opposite polarity, however, so the magnetic fields balance and the spot remains stationary, as Fig. 6A illustrates. During high speed flyback the fields aid and the spot moves rapidly to the next position along the line. All high speed transistors are separate from the overall beam movement.

The *X* and *Y* main deflection amplifiers are identical and consist of phase and paraphase see-saw amplifiers feeding a push-pull deflection coil, Fig. 6B, with a top boost circuit connected to the center tap of the coil. This circuit increases the rail voltage during flyback to return the spot after full deflection in less than 140 μ sec. Shift voltages allow positioning the format on the screen. Input to the *X* amplifier is the slow time base waveform but input to the *Y* amplifier is a position shift voltage which remains steady for one complete line.

Cancellation Sawtooth—The *X* auxiliary amplifier contains a Miller

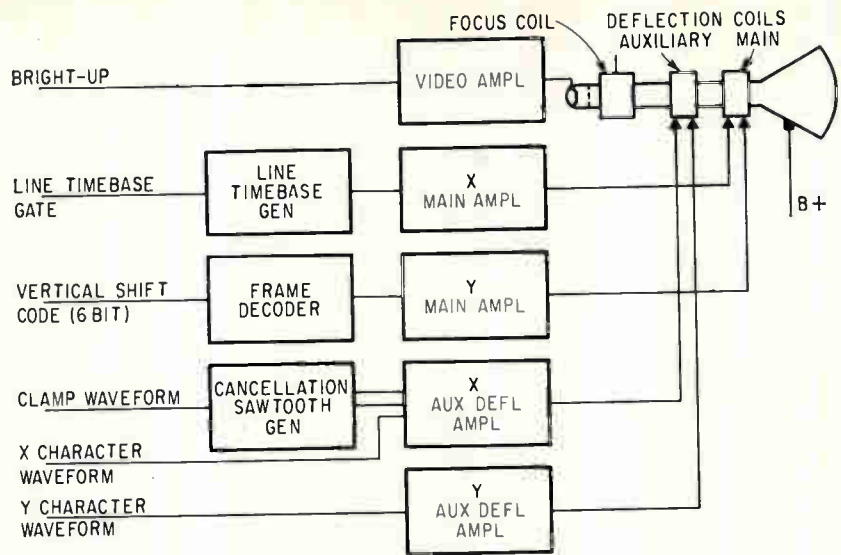

DISPLAY UNITS use dual deflection coil system to obtain wide bandwidth needed for high speed character writing—Fig. 5

integrator which is clamped by the symbol clamp waveform from the central equipment. This produces the cancellation sawtooth which is mixed in the deflection coil with the *X* character waveform from the central equipment. The composite waveform is then fed into a pair of transistors connected in the Darlington 5 configuration to ensure linearity. A simplified diagram is shown in Fig. 6C.

The *Y* auxiliary amplifier has only one input, the *Y* component character waveform; another Darlington pair operates as a linear voltage to current converter.

While the deflection waveforms are common to all displays, independent bright-up waveforms are received from the central equipment. Essentially the video amplifier is an on-off device that takes

the digital output at 2 volts and amplifies it to 30 volts to drive the grid of the crt. Edges of the pulses have rise and fall times of better than 0.1 microsecond. A further feature is a scan failure protection, which cuts off the beam in the absence of scanning waveforms.

The authors thank the Director of Engineering and Research, Marconi's Wireless Telegraph Co. Ltd. for permission to publish this paper and their colleagues for helpful comments in its preparation.

BIBLIOGRAPHY

- W. N. Papian, Coincident Current Magnetic Memory Cell for the Storage of Digital Information, *Proc IRE* 40, 1952.
- J. A. Rajchman, A Myriabit Magnetic Core Matrix Memory, *Proc IRE* 41, 1953.
- A. A. Robinson, Y. L. Newhouse, M. J. Freidman, D. G. Binson, I. P. V. Carter, A Digital Store Using a Magnetic Core Matrix, *Proc IEE* Paper 2040M, March 1956.
- C. J. Quartly, A. L. Cain, R. W. Clarke, A Matrix Store for Data Rate Conversion, *Proc IEE Convention on Ferrite*, Oct. 1956.

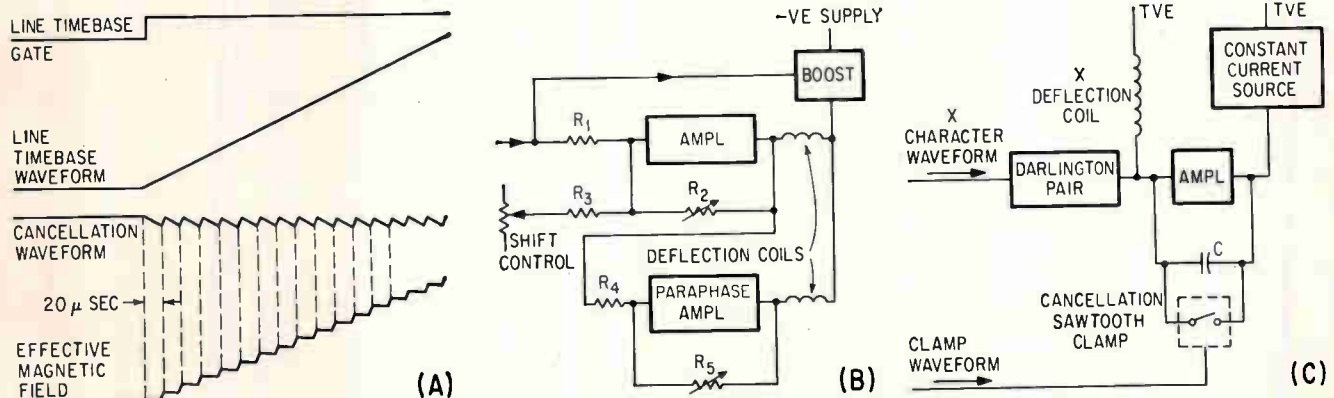

WHEN CANCELLATION sawtooth is added to line timebase wave, a staircase or stepping type magnetic deflection field is obtained (A). Main and auxiliary amplifiers in simplified form (B) and (C)—Fig. 6

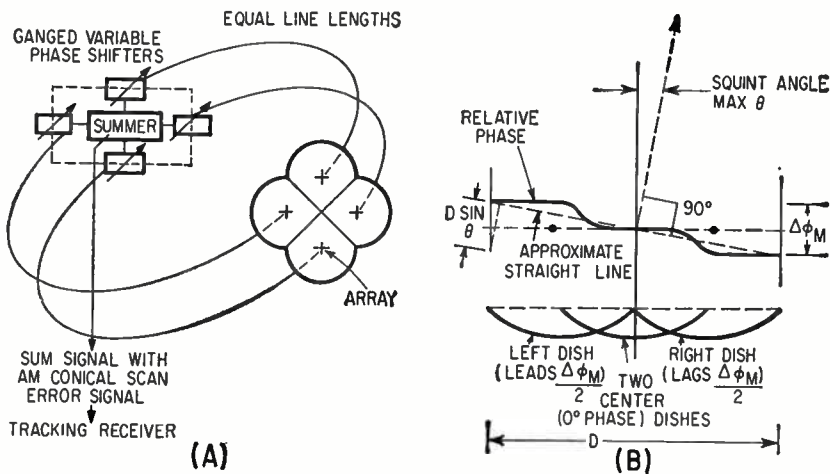

CONICAL SCANNING uses variable phase shifter in series with each antenna element to sequentially squint antenna secondary pattern—Fig. 1

Conical Scan

By L. R. YOUNG
C. A. LOVEJOY
L. E. WILLIAMS
Radiation, Inc., Melbourne, Fla.

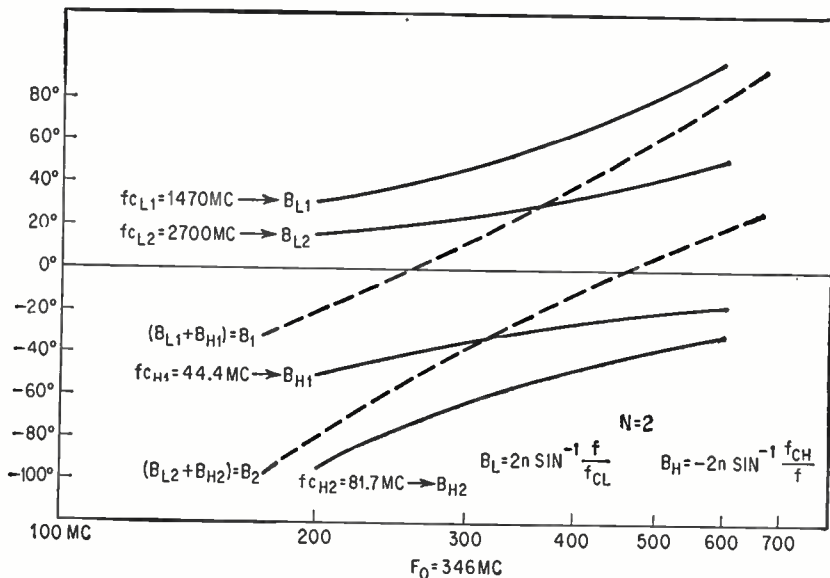

THEORETICAL maximum and minimum phase shift as function of frequency for 2-section low-pass, 2-section high pass phase shifter—Fig. 2

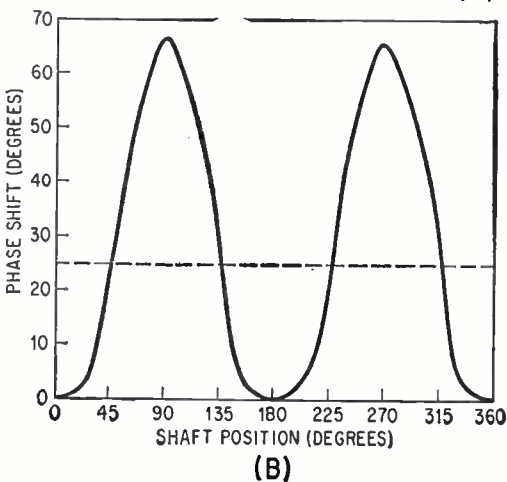
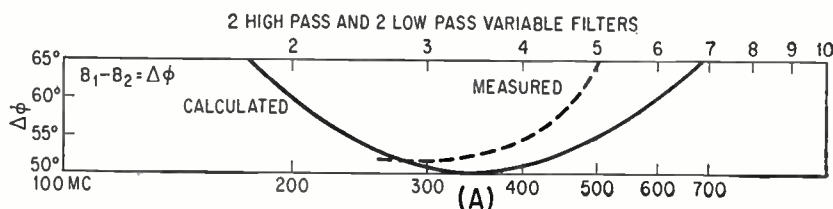

DIFFERENTIAL phase shift (A) across a greater than 3:1 band. Relative phase shift versus shaft rotation (B) at 500-Mc—Fig. 3

A **BROADBAND ANTENNA** array capable of operating over a bandwidth of a decade or more was designed with a cluster of four parabolic reflectors in a diamond arrangement, with each reflector fed by a frequency independent feed.¹ Used as a monopulse automatic tracking system, hybrid comparators and three-channel monopulse receivers had to be added to cover the entire frequency band. The system became complex and expensive.

To simplify the system, and reduce cost, a conical scan technique was developed, using a variable phase shifter in series with each element of the array for error signal generation, and a single-channel a-m tracking receiver.

Phase Shifters—Most phase shifters are essentially “line-stretchers” and phase shift, for a given change in electrical length, varies directly with frequency. For broadband conical scan and to maintain a constant crossover depth with the array, a constant differential phase shift with frequency is required. “Line-stretcher” phase shifters are limited to frequency bands less than 2:1. The combination of high-pass and low-pass constant-K filter phase shifters described here have a theoretical differential phase shift constant within approximately ± 10 percent over a 3:1 frequency band.

Scanning by diode switching or varactor filters tends to be noisy and introduces more insertion loss than a simple passive non-contacting variable filter.

Array Uses Variable Phase Shifters

Two broadband antenna systems, each with four parabolic reflectors in a diamond array and log-periodic feeds, were adapted for automatic vhf and uhf tracking, using conical scanning. Results—less complexity and lower cost

Scanning Method—Conical scanning by variable phase shifters is shown in Fig. 1A. Four variable phase shifters, one in series with each antenna element, are driven in proper electrical phase to sequentially squint the antenna secondary pattern around boresight, producing conical scan.

As frequency increases, antenna beamwidth decreases and amount of squint required for a particular value of crossover reduces in proportion. Differential phase shift (Fig. 1B) to maintain a constant crossover level with fixed element spacing for conical scan is derived

$$BW \approx \frac{64 \lambda}{D} \text{ degrees}$$

where maximum squint angle equals

$$\theta_{\max} = K(BW) = \frac{64 \lambda K}{D} \text{ degrees}$$

The maximum differential phase shift between right and left elements equals

$$\Delta \phi_M = \frac{2 \pi D}{\lambda} \sin \theta$$

Assuming $\sin \theta \approx \theta$ (small angles), then

$$\Delta \phi_M = \frac{2 \pi D}{\lambda} K \frac{64 \lambda}{D}$$

or $\approx K 400$ degrees at all frequencies or $\pm K 200$ degrees.

It is assumed that the phase across the antenna aperture is constant over the surface of each reflector, and that the two center reflectors have the same relative phase, while the reflector on one

side is advanced in phase and the reflector on the other side is retarded. The effective phase across the entire aperture essentially steps between the three levels. If maximum differential phase shift between opposite reflectors is less than 65 degrees, maximum phase error across the aperture, with respect to assumed linear phase, is less than 1/20 wavelength. Phase errors of this order do not seriously affect antenna gain. Beamwidth = $64\lambda/D$, was determined from experimental measurements on similar antennas.

Flexibility—The variable phase shifters are physically small and can be operated at relatively high scan rates as compared to the more general nutating feed systems. The feed systems are orthogonally polarized; horizontal and vertical or right- and left-circular polarizations are available. The operator can track with one polarization using conical scan, and receive with orthogonal polarization without conical scan, for full antenna gain.

An alternate method is to conically scan both polarizations and

A BETTER MOUSETRAP

Four-element broadband arrays can be conically scanned, using variable high-pass low-pass constant-K phase shifters, over a frequency band approaching 4:1 with essentially constant crossover. This scan method also uses a single-channel a-m receiver for automatic tracking. The system is both less costly and complex than monopulse counterparts; and the scanner reaches rates of 100 cps

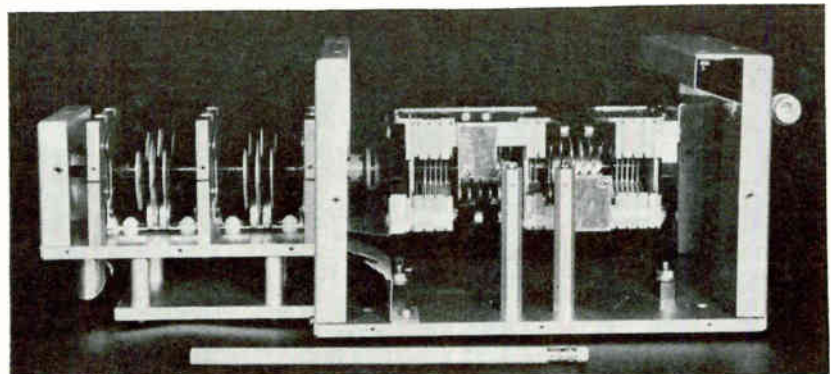

SMALL 135 to 265-Mc phase shifter has scan rates of 100 cps or more

select the one with a larger signal level for the tracking signal and also the data channel. Various combining techniques are also possible. The two polarizations can be scanned 180 degrees out of phase and the error signals combined, to cancel the effects of amplitude modulation, produced by the source or propagation path, that might fall in the scan frequency band.

The Scanner—A typical noncontacting phase shifter consists of a network of two low-pass π sections, and two high-pass T sections. Each L and C element is variable, all varying together, being maximum or minimum at the same time. The lumped inductances are varied by inserting conductors between the coil turns.

If the L/C ratio remains constant, impedance remains virtually constant far into the pass band. Cutoff frequency varies inversely as \sqrt{LC} for both filter sections. Cutoff frequency of the high-pass filter is minimum when cutoff frequency of the low-pass filter is minimum. The phase shift characteristic of a single T section high-pass filter is negative and varies from $-\pi$ at cutoff towards zero with increasing frequency. The phase shift characteristic of a single π section low-pass

filter is π at cutoff and approaches zero with decreasing frequency.

Figure 2 is a phase shift plot of a two section low-pass and two section high-pass phase shifter. The upper curves (B_{L1} and B_{L2}) show phase shift extremes across a 3:1 band for the low-pass filter when cutoff varies from 1,470 to 2,700-Mc. The lower curves (B_{H1} and B_{H2}) are for the high-pass filter with a variation in cutoff from 81.7 to 44.4-Mc. Curves B_1 and B_2 are the overall phase shift of the combination showing $B_1 = B_{L1} + B_{H1}$ and $B_2 = B_{L2} + B_{H2}$. The difference between B_1 and B_2 is the differential phase shift across the combination as the two cutoff frequencies are varied.

Plot of differential phase shift across a greater than 3:1 band is shown in Fig. 3A. Cutoff frequencies were set so that the band center (minimum differential phase shift) was 50 degrees. Total tolerance allowed was 50 to 65 degrees, and this tolerance allows a 3.9:1 band. The experimental points are taken from a phase shifter similar to the one described. The band from 265 to 500-Mc is not centered, nor is the minimum at 50 degrees, but the phase shift is easily within tolerance limits for this relatively narrow band.

A complete scanner is four phase shifters connected through a four-way power divider and adjusted in relative phase with opposing phase shifters 180 degrees, and adjacent phase shifters 90 degrees, out of phase.

Figure 3B is relative phase shift of a single phase shifter versus shaft rotation. A 135 to 265-Mc phase shifter, with cover removed, is shown in the photograph.

Complete Systems—Recently, two systems were delivered to the PMR (Pacific Missile Range) for use at South Point, Hawaii.² Both systems use four reflectors 10 feet in diameter. The vhf system covers from 135 to 265-Mc using orthogonal log-periodic dipole feeds. Orthogonal-linear or orthogonal-circular polarization can be selected for the outputs. A block diagram of the r-f (vhf) subsystem is shown in Fig. 5.

The second PMR system covers four uhf bands: 265 to 530; 530 to 1000; 1400 to 1550; and 2200 to 2300-Mc; with orthogonal triangular-tooth log-periodic feed elements. The block diagram of the r-f (uhf) subsystem is similar to Fig. 6, with the addition of multiplexers between the log-periodic feeds and the polarization transducers, and increase of preamps and multicouplers to 8.

UHF Multiplexers—It was necessary to separate the individual frequency bands using frequency multiplexers so that each polarization transducer and scanner could function independently over a frequency band less than 2:1. The polarization transducers are so connected that horizontal and vertical polarization can be combined with an approximate 90 degrees phase shift to produce right-circular and left-circular polarization at the hybrid output parts, or, the horizontal and vertical can be connected directly to the output. Hybrids are also used to combine the outputs from the individual scanners.

REFERENCES

- (1) L. E. Williams, A New Broadband Tracking Antenna, 12th Annual Symposium of USAF Antenna Research and Development; Oct. 1962.
- (2) The antenna systems described were constructed for the PMR under Contract N123 (61756) 32597A.

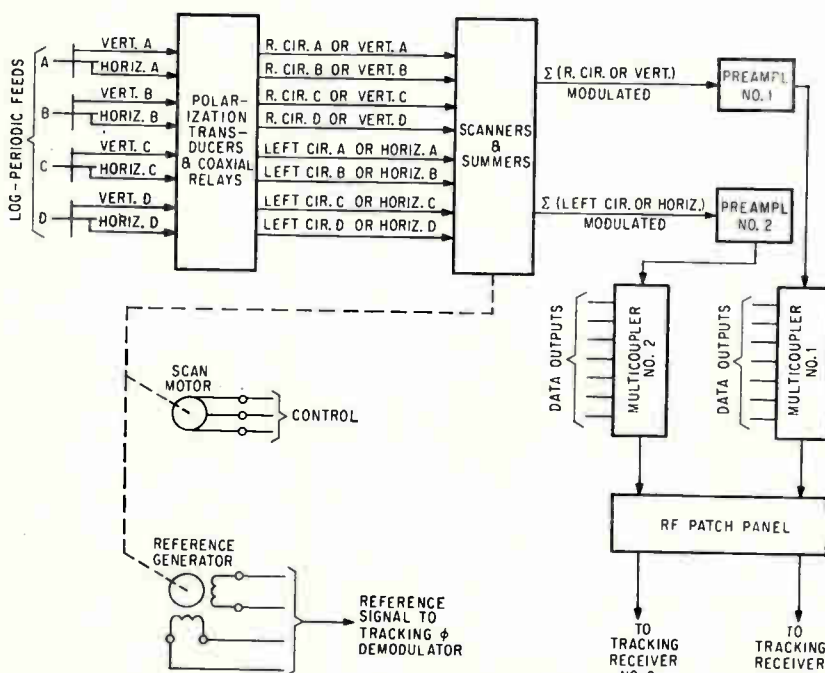

R-F (VHF) SUBSYSTEM covers from 135 to 265-Mc using orthogonal log-periodic dipole feeds; uhf r-f subsystem is almost identical—Fig. 4

UPDATING A SCOPE

Despite the fine signal to noise properties of digital data, things still go wrong. Transistors fail, wires short, connectors sometimes don't get connected, lightning strikes. A good close look at the loused up data—on an oscilloscope, for example—can help at such times. But you usually can't get enough data at high enough resolution on the typical one-trace scope. What to do?

Circuit Converts ONE-TRACE SCOPES to Raster Display

Regular oscilloscopes are used to display 16 digital words in troubleshooting technique. Lightweight, inexpensive circuit can be adapted to meet special needs of various EDP systems

By **BRUCE S. WHITE**, Lawrence Radiation Laboratory,
University of California, Livermore, California

WHEN DATA is used in a system in digital, serial form, it may become necessary to observe the information word by word in a static display. The display may show drop-outs occurring at a tape recorder output or may spot a failure or malfunction in a particular portion of the system. Prior to use, system operation can be checked and errors caused by noise or weak signals in the transmission link can be analyzed.

Readout is usually obtained from a direct writing oscillograph using high-speed galvanometers. But if the data has a fast repetition rate, the waveforms may be unreadable because of the limited bandwidth of the oscillograph. In addition, the direct-writing oscillograph is not easily portable since

it was not designed for field use and its cost may be too high for some applications.

Visual readout can also be obtained from a photograph of an oscilloscope trace. The usual limitation here is that only one sweep per photograph is obtained; thus the number of words that can be photographed per sweep is limited by the resolution of the scope.

A raster oscilloscope increases the resolution by allowing more than one sweep. But raster scopes are expensive and may not be justifiable for each location where they would be desirable. Portability, also, is a problem.

Since oscilloscopes are usually available at all sites where signal checking might be desired, an inexpensive, light weight (5 lb) digital

scope readout was developed. Operation is digital since all commands to control the vertical and horizontal sweeps are slaved to signals derived from the digital data. The data is displayed and photographed as shown in the raster display of Fig. 1, thus providing much higher resolution than a single sweep display for the same number of words.

System—In the system for which the scope readout was developed—a system to diagnose fast, wide dynamic range transients from multiplier photo tubes and photodiodes—the data appears in a binary-coded-decimal pulse duration modulation format, with 16 bits per word and a two-bit gap between data words. This digital data contains information such as digitized time interval



PHOTOGRAPH OF DIGITAL data is obtained in raster form from single-trace scope

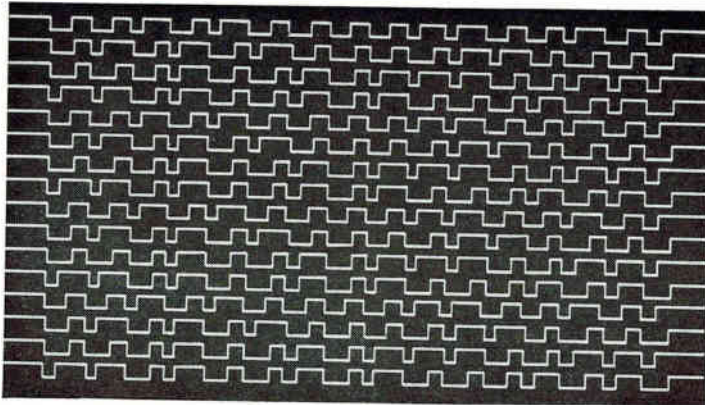

ONE LINE or trace is used for each 16-bit digital word in raster display using regular oscilloscope (left photograph). Waveform (A) is digital data before being expanded into raster display. Other waveforms, (B) through (G), correspond to similarly labeled points in Fig. 2, the block diagram of the raster generator—Fig. 1

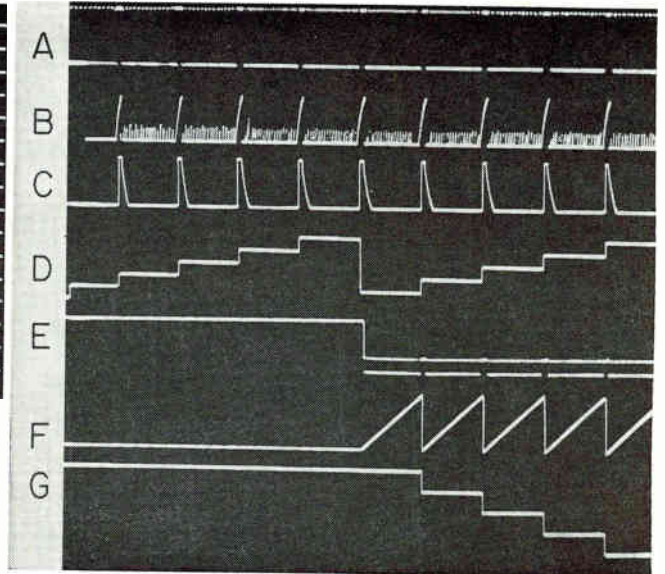

measurements, or data from transducers whose analog outputs have been converted to digital form and then multiplexed into a serial output. These two types of information are transmitted, on separate channels, to a remote station and stored on magnetic tape. Each channel contains approximately 50 words of data.

In the normal situation this information is played into digital data processors and the information is read out automatically on an 11-line printer. If a malfunction occurs in the line from transducers to printer during staging of the system or at actual test time, the information printed out might be incorrect and it would then be necessary to observe the data visually, at each part of the system, to determine the causes of the errors.

Operation—The waveforms of Fig. 1 are keyed to the block diagram, Fig. 2. Input information, Fig. 1A, passes through the emitter follower buffer, Fig. 2, and triggers a single-shot with a duty cycle of approximately 70 percent. Spaces between words, integrator output rises higher than for the gap between bits. At a preset amplitude, the schmitt trigger fires, Fig. 1C, sending signals to the horizontal sweep generator, the vertical staircase sweep generator, and the sync delay circuit. Before the sync delay counter, Fig. 1D reaches its preset count, the data is held at a pedestal voltage, Fig. 1E, keeping the beam off the scope face for blanking. If, for example, the sweep is to be initiated after the third word, the sync delay counter

is preset to a three count. Before the third count, the sweep hold flip-flop is reset, clamping the sweep off the screen to the upper left side of the scope face. At the third count the sync delay is fired, setting the flip-flop, which allows the horizontal sweep generator to begin its ramp, Fig. 1F, and the vertical sweep generator to begin its stair-stepping action, Fig. 1G. Thus the sweep generators are controlled by the pulse occurring at the end of each complete word. Sweep retrace time is less than $1 \mu\text{sec}$ so no information is lost during retrace.

Data is summed with the stairstep, whose step duration is the length of one complete word. Also, at the preset count time, the first data word drops to the scope face, Fig. 1E. The vertical staircase steps until it reaches the end of its dynamic range, at which time there is no reset, so the sweep goes off the screen, thereby preventing double traces. The user can now exhibit a certain fixed number of words on the scope face. The data photograph of Fig. 1 shows 16 complete consecutive words in the 16-bit bcd, pdm format. If desired, the sync delay can be set to 16 to enable the following 16 words to be photographed. In Fig. 1 there is 10-msec of data per photograph with a time resolution of less than $5 \mu\text{sec}$. The same information, using only one sweep, is shown in Fig. 1A.

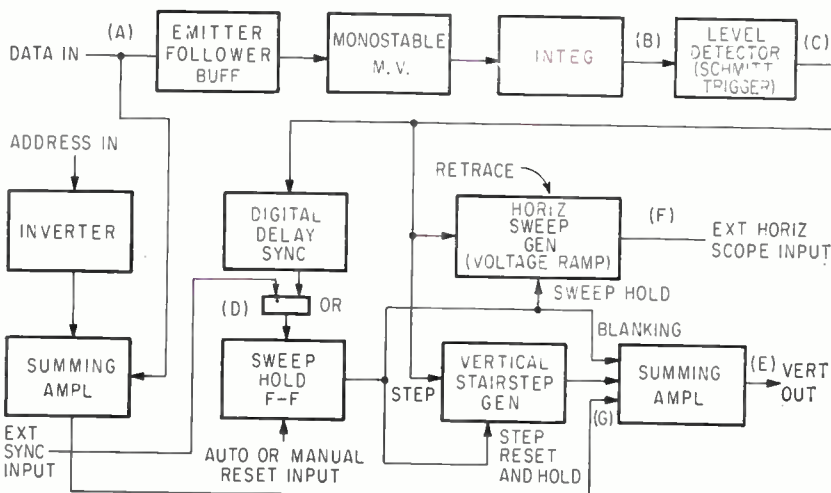

ONE MAJOR function of the circuit is to detect the 2-bit gap between words, which is accomplished by the integrator and the level detector—Fig. 2

Design—Circuits, Fig. 3, are straightforward. The horizontal sweep consists of a common transistor base, Q_1 , supplying constant

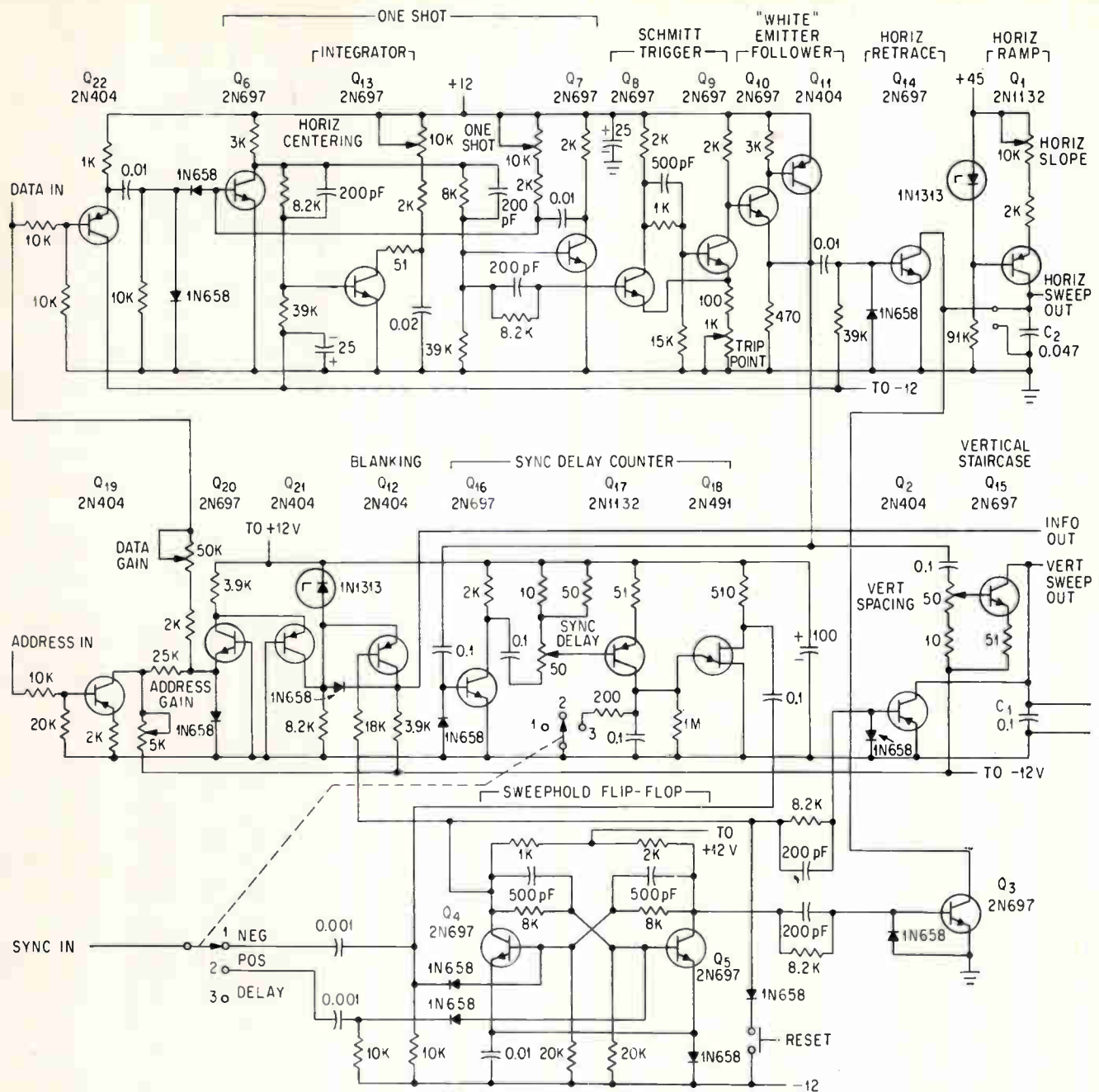

IF DATA SYSTEM does not have a gap between words, a counter can be substituted for the gap detecting circuits; a counter can also be used to display more than one digital word per trace—Fig. 3

current to a capacitor to generate a linear ramp voltage. If necessary, Q_1 can be replaced by a field-effect transistor or transistors in series so a higher voltage ramp can be generated. The vertical sweep and the sync delay are similar in operation, consisting of biased-off, common emitter circuits that supply pulse current to capacitors to perform stairstep generation. The unijunction transistor in the sync delay circuit serves as a switch to discharge the sync delay capacitor when its voltage reaches a preset level. The remainder of the circuit consists of standard bistable and monostable multivibrator circuits, Q_4 - Q_5 , and

Q_{10} - Q_{11} . When the sweep hold flip-flop is reset, transistors Q_2 and Q_3 are saturated, clamping sweep capacitors C_1 and C_2 to ground. Because of the heavy capacitive loading of the schmitt trigger circuit, Q_8 - Q_9 , a complementary white emitter follower, Q_{10} - Q_{11} , is used as a driver to maintain fast rise times for short retrace time. Transistor Q_{12} acts as a switch to clamp the trace off the screen when the sweep hold flip-flop is reset so that the camera shutter may be left open prior to t_0 .

Power supplies in the units (not shown in Fig. 3) can either be batteries or simple zener diode voltage regulators as convenient, since regu-

lation is not critical.

With minor modifications to fit the particular situation, the system can be made compatible with almost any type of information. If there is no space between words, for example, a counter can be substituted for the gap detector to determine word length. A counter can also be placed between the gap detector and the horizontal sweep so more than one word can be presented for each horizontal sweep. The raster may be made repetitive by resetting the vertical sweep with a periodic signal.

The work was performed under the auspices of the U. S. Atomic Energy Commission.

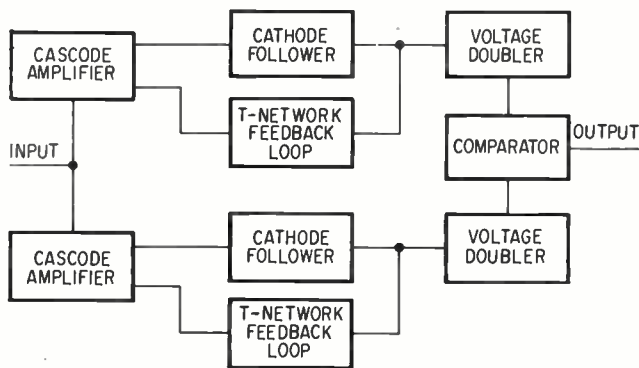

COMPLETE discriminator—Fig. 1

CIRCUIT can use three types of rejection networks: the twin-T, bridge-T, or the inside-out-T—Fig. 2

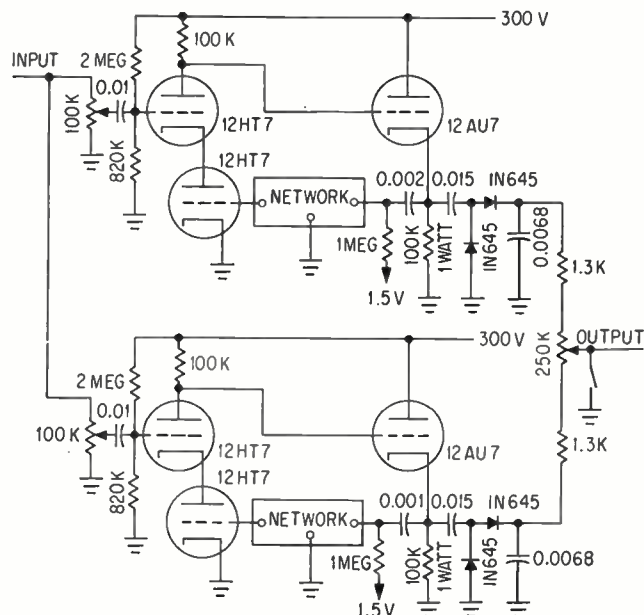

F-M DISCRIMINATOR Without Tuned Circuits

By **H. D. CRAWFORD**, Associate Professor
School of Electrical Engineering, Oklahoma State Univ.
Stillwater, Okla.

A. B. HALE, Captain, USAF

FEW CIRCUITS are available to measure frequency modulation with deviations of 1 cps at rates of from zero to 100 cps. Those which use LC components and, it was felt, would not perform adequately in the system we were designing.¹

We decided to use a twin-T circuit in a feedback loop to serve as the resonant circuit in a Foster-Seely type of discriminator.² The Foster-Seely discriminator consists of two, tuned LC circuits. One circuit tuned above the center frequency, the other below the outer frequency. The output of each resonant circuit is rectified and the resultant low frequency added together. When the Q's and center frequency of the resonant circuits are properly adjusted, the resultant output gives the familiar discriminator response.

We simulated the resonant circuits using RC elements in the feedback loop of an amplifier. Fleisher has shown that if the forward gain of a cascode amplifier is sufficiently large, and a rejection network is included between the output and one of the grids of the cascode, the resulting response is very close to that of a tuned LC circuit.³ Figure 1 is a block diagram of a complete discriminator. The upper cascode amplifier, cathode follower and feedback loop simulate the

tuned circuit which "resonates" slightly above center frequency. The lower amplifier, feedback loop, and cathode follower perform the same function at a frequency less than the center frequency.

Rejection Networks—Figure 2 shows the actual circuit. The rectifiers are of the voltage doubling type. Besides the twin-T rejection network, a bridge-T or an inside-out-T also works well. The circuit, as shown, works quite well up to 500-kc and could be made to work at higher frequencies, if care is taken to minimize stray capacities.

We see no reason why the frequency range cannot be extended. It is also quite possible that a transistor version could be built, although this was not done. Naturally, these circuits must be preceded by a limiter of suitable range. Coryell has examined more complicated circuits from a theoretical viewpoint. He gives explicit design procedures for more complicated amplifiers using feedback loops to stabilize forward gain.⁴

REFERENCES

- (1) United States Public Health Service research grant provided support for this project.
- (2) Foster-Seely, Automatic Tuning: Simplified Circuits and Design Practice, Proc. of I.T.E., 25, 1937.
- (3) H. Fleisher, Low Frequency Tuned Amplifiers in Vacuum Tube Amplifiers, M.I.T. Radiation Lab., 18, Chap. 10.
- (4) D. A. Coryell, Design of a Narrow Band Frequency Modulation Discriminator, M.S. Thesis, School of Electrical Engineering, Okla. St. Univ., Aug. 1961.

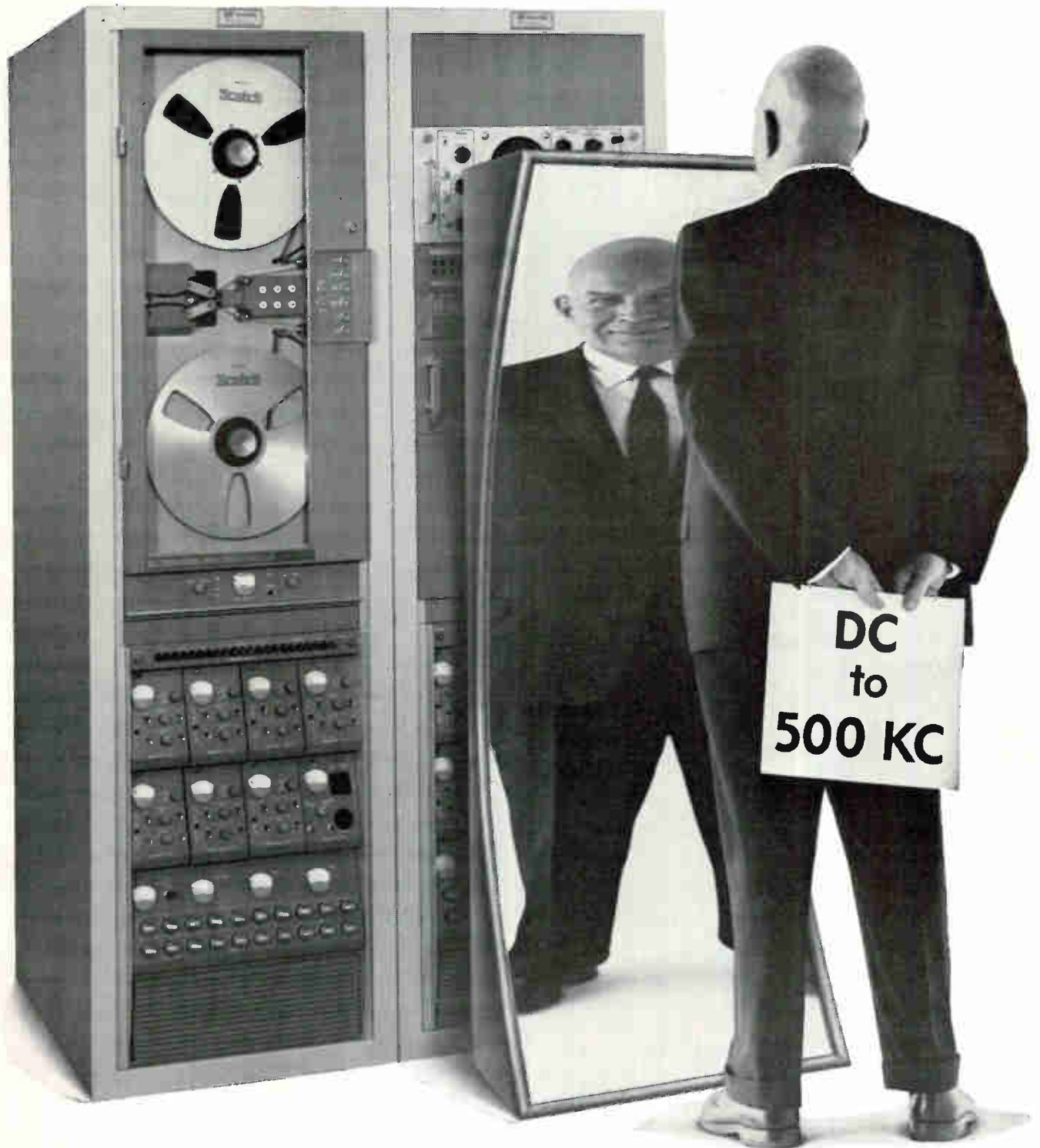

WIDEBAND FM recording, using 1.5-megacycle analog techniques to attain an improved frequency response of DC-500 kc, is Mincom's latest telemetry development. Heart of the new system is the standard **Mincom 1.5-mc CM-114 Recorder/Reproducer**. The extended FM responses enable telemetry facilities to record simultaneously the most complex narrow-band and wideband signals in PCM, PCM/FM, PDM, and FM/FM modulation. More advantages: Extended low frequency response, excellent linearity, seven or fourteen recording tracks, versatility without modification, greater dynamic range, dropout reduction virtually to zero. Write today for details and complete specifications.

Mincom Division **3M**
COMPANY
2049 South Barrington Avenue, Los Angeles 25
425 13th Street N. W., Washington 4, D. C.

New RDF Is Loopless

System uses stationary
uhf-vhf dipole arrays
to reduce site errors

QUASI-DOPPLER radio direction finder (rdf) being built for FAA uses a single, stationary array antenna—rather than the conventional loop and sense antennas—to determine the bearing to a transmitter.

The system can be installed at sites not previously suited for conventional direction finders because of its inherent site-error suppression capabilities, reports Servo Corp. of America. Servo is producing the system under a \$2.7-million contract with FAA.

Initially, the system will be used primarily for emergency position verification of aircraft equipped with radio communications receivers and transmitters. With the system, a ground controller can obtain the aircraft bearing as the rdf receives the aircraft's communications signal. At the same time, the controller can communicate with the pilot to guide him to the airport or station.

Small airports without vor, tacan or other navigation aids can use the system as a primary navigation aid as well as in emergencies. Doppler direction-finder systems such as this, said a Servo spokesman, are expected to help improve air safety and air navigation.

System Components—Each system supplied by Servo—designated Model FA-5530 D.F. by the FAA—will include a dual-array antenna, a vhf/uhf receiver with 20 crystal-controlled automatic channels (10 vhf and 10 uhf), a local indicator that displays fully sensed (unambiguous) aircraft bearings on its 7-inch cathode-ray tube, and a remote in-

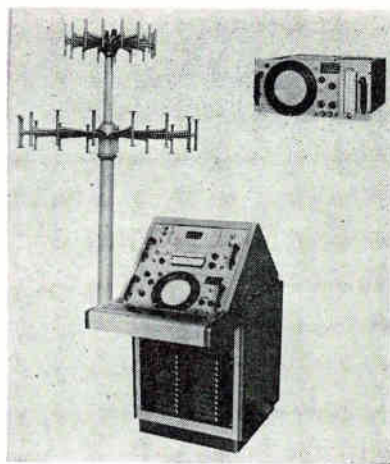

COMPONENTS of system are array antenna, 20-channel receiver and local indicator (bottom), and remote indicator/control. Aircraft bearing is shown as a strobe line on the crt

dicator/control that can be operated up to two miles away from the local indicator and receiver.

The antenna has two concentric arrays—one for vhf reception and one for uhf reception. Each array has 16 dipole elements, equally spaced around the mast (see photo). The dipoles are electrically commutated sequentially and the resultant signal applied to the receiver. The direction-finding equipment demodulates the signal and provides azimuth information as a solid strobe line on the crt indicator.

Microwaves Split Granite, Concrete

LONDON — Microwaves might replace pneumatic drills in rock splitting and maybe destroy dry rot in brickwork and woodworm in timber, tests here show. Mullard Ltd., using a 10-kw, c-w 2,450-Mc generator inserted through 18-inch holes into granite, produced cracks in three minutes. The technique could be applied also to concrete, the firm says. Experiments performed by the British Building Research Station cracked a concrete wall 5 feet square and 9 inches thick with two three-minute blasts from a taper waveguide propagating 2 kw. A 20-kw, 915-Mc source aimed at reinforced concrete caused explosions that separated the concrete from reinforcing rods. Station also sees promise against dry rot and woodworms.



AVAILABLE AT THESE DIST

EAST

Binghamton, N. Y.—Federal Ele
P. O. Box 208/PI 8-8211
Philadelphia 23, Penn.
Almo Industrial Electronics, I
412 North 6th Street/WA 2-
Pittsburgh 8, Penn.—Radio Parts C
6401 Penn Avenue/EM 1-
Newton 58, Mass.—Greene-Sha
341 Watertown Street/WO 9-
New York 36, N. Y.—Harvey Radio
103 West 43rd Street/JU 2-1
Baltimore 1, Md.—Radio Electric Serv
5 North Howard Street/LE 9-

SOUTH

Birmingham 5, Ala.—Forbes Distributing
2610 Third Avenue, South/AL 1-
West Palm Beach, Fla.—Goddard
1309 North Dixie/TE 3-5701
Richmond 20, Va.—Meridian Electro
1001 West Broad Street/353-

MIDWEST

Detroit 3, Mich.—Glendale Electronic Sup
12530 Hamilton Avenue/TU 3-1
Minneapolis 16, Minn.—Admiral Distr
5305 Cedar Lake Road, St. Louis Park
Indianapolis 25, Ind.—Graham Electronics
122 South Senate Avenue/ME 4
Cleveland 1, Ohio—Pattison Supply
Main Line Electronics Divisi
777 Rockwell Avenue/EX 1-4
Chicago 30, Ill.—Merquip Electronic
4939 North Elston Avenue/AV 2-
Cincinnati 10, Ohio—United Radio
1308 Vine Street/CH 1-6530
Kansas City 11, Mo.—Walters Radio S
3635 Main Street/VA 1-8058
St. Louis 44, Mo.—Electric Compo
Industry Co., Inc.
2605 Henley Road/MI 7-5505

WEST

Dallas 1, Texas—Adleta Compa
1907 McKinney Ave./RI 1-315
Houston 1, Texas—Harrison Equipment Co
1422 San Jacinto Street/CA 4-91
Monrovia, Cal.—Lynch Electronics
1818 South Myrtle Avenue/EL 9-8261/
San Diego 1, Cal.—Radio Parts Com
Division of E.C.I., 2060 India Street/
Los Angeles 15, Cal.—Radio Products S
1501 South Hill Street/RI 8-127
Mountain View, Cal.—Kierulff Electr
2484 Middlefield Road/968-6292
Denver, Colo.—L. B. Walker Radio Co
300 Bryant Street/WE 5-2401
Seattle 1, Wash.—C & G Electronics
2221-3rd Avenue/Main 4-4355
Albuquerque, N.M.—Midland Specialty
1712 Loma Blvd., N.E./247-2486
Phoenix, Ariz.—Midland Specialty C
1930 North 22nd Ave./258-4531
Tucson, Ariz.—Midland Specialty Co
951 South Park Ave./MA 4-2315

Ask for a complete catal

DELCO
DEPENDABILITY
RADIO
RELIABILITY

Division of General Motors, Kokomo, Ind



Delco announces two new silicon power transistors

No.	V _{ce} I _{ce} = 5ma Sustaining	V _{ce} Sustaining	h _{FE}		V _{ce} Sat.		V _{be} Sat.	
			I _c = 5A	I _c = 10A	I _c = 5A	I _c = 10A	I _c = 5A	I _c = 10A
2N3079	200	200v	10 min. 50 max.		0.7v		1.5v	
2N3080	300	300v	10 min. 50 max.		0.7v		1.5v	
2N2580	400	325v	10 min. 40 max.		0.7v		1.5v	
2N2581	400	325v	25 min. 65 max.	10 min.		1.0v		1.7v
2N2582	500	325v	10 min. 40 max.		0.7v		1.5v	
2N2583	500	325v	25 min. 65 max.	10 min.		1.0v		1.7v

The 2N3079 at 200 V and 2N3080 at 300 V join Delco's 400 and 500 V units to expand our line of high power, high voltage silicon transistors. The new units come with safe operating curves to help designers use the devices more effectively. At the same time, a significant price reduction recommends the 400 and 500 V units for more applications than ever before. And all 6 Delco Radio devices have high sustaining voltage capabilities: 325 V on the 400 and 500 V units, and 200 and 300 V on the 200 and 300 V units respectively. They're all *in production* and *available now* through Delco Radio semiconductor distributors or any of our sales offices.

*Union, New Jersey
324 Chestnut Street
MURdock 7-3770
AREA CODE 201

Detroit, Michigan
57 Harper Avenue
TRinity 3-6560
AREA CODE 313

Palo Alto, California
201 Town & Country Village
DAvenport 6-0365
AREA CODE 415

*Santa Monica, California
726 Santa Monica Blvd.
UPTon 0-8807
AREA CODE 213

Syracuse, New York
1054 James Street
GRanite 2-2668
AREA CODE 315

*Chicago, Illinois
5151 N. Harlem Ave.
775-5411
AREA CODE 312

*Office includes field lab and resident engineer for applications assistance.

General Sales Office: 700 E. Firmin, Kokomo, Ind., Gladstone 2-8211—Ext. 500 • Area Code 317

DELCO
DEPENDABILITY
RADIO
RELIABILITY

Division of General Motors, Kokomo, Indiana

Acoustical Components of Superior Quality

JAPAN PIEZO supplies 80% of Japan's crystal product requirements.

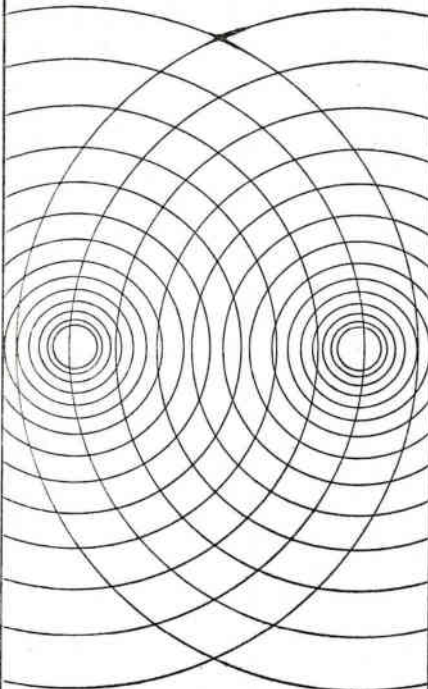

STEREO CARTRIDGE

Crystal — "PIEZO" Y-130

X'TAL STEREO CARTRIDGE

At 20°C, response: 50 to 10,000 c/s with a separation of 16.5 db. 0.6 V output at 50 mm/sec. Tracking force: 6 ± 1 gm. Compliance: 1.5×10^{-6} cm/dyne. Termination: $1M\Omega + 150$ pF.

Write for detailed catalog on our complete line of acoustical products including pickups, microphones, record players, phonograph motors and many associated products.



JAPAN PIEZO ELECTRIC CO., LTD.

Kami-renjaku, Mitaka, Tokyo, Japan

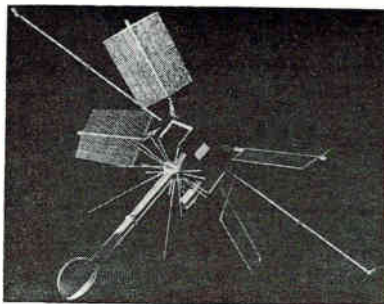

SATELLITE carries nine experiments contributed by the Universities of California and Chicago, MIT, NASA Goddard Space Flight Center and Ames Research Center

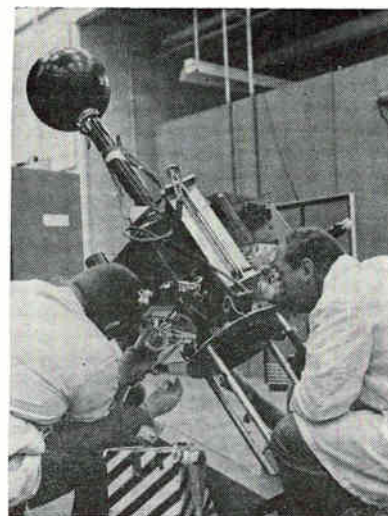

Slow Sampling Saves Time

IMP's ground stations will only work part-time to process data

WASHINGTON — A pulse-frequency-modulation encoder that handles data 16 times faster than it is collected is to be flown aboard NASA's Interplanetary Monitoring Platform, IMP.

The satellite, designed to gather data on solar flares and other interplanetary radiation and magnetic fields, was to be launched November 12. The launch was postponed to this week to allow changes that

would prevent outgassing on the third stage from contaminating the spacecraft and damaging solar cells on paddles. The stage-separation time, formerly 20 minutes, was reduced.

Encoder—IMP's encoder will have a sampling rate 1/16 that of Explorer XII's (3.125 samples per sec, instead of 50). This has the effect of decreasing the noise bandwidth by 16. Transmitter output is 4 watts.

Data will be recorded only one hour out of every four, allowing ground stations to be used only part-time and permitting three months of data to be processed in less than two weeks.

The digital data equipment in the encoder has 12 accumulators with a total capacity of 135 bits. They can be reset after each read-out, or continuously accumulate. Information is telemetered three bits at a time in a 0.16-sec burst. A 15-bit word will be telemetered in five samples rather than the usual 15-sample method, by using a 3-bit sub-carrier oscillator whose output frequency may be one of 8 discrete frequencies corresponding to 3 bits. The subcarrier frequencies are 312.5 to 937.5 cps.

Experiments—IMP will carry nine experiments into a highly elliptical orbit with a lifetime estimated at one year. Three experiments are designed to gather data on solar flares, expected to be a major problem dur-

Polaris' New Guidance

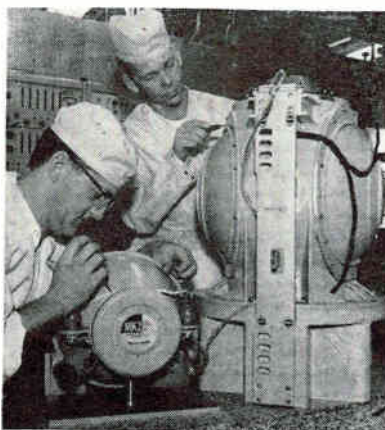

FIRST MARK II inertial guidance platform made by Honeywell for Polaris is shown with the last Mark I, three times the size and weight

ing lunar and interplanetary manned flight.

A plasma probe will measure flux of low-energy positive particles. Charged particles pass through a series of grids set at potentials that reject electrons and low-energy positive particles. An electrometer circuit detects the number of charged particles reaching the collector.

A range-energy loss telescopes with solid-state detectors, a 64-channel pulse height analyzer and range logic will search for solar-proton or alpha-flare events. Two geiger-counter telescopes will give data on solar-proton events and cosmic-ray modulation.

Other experiments include a package to determine energy and charge spectra, a Neher-type ion chamber, low-energy proton analyzer, thermal ion and electron experiment, and rubidium and two fluxgate magnetometers.

Phosphor Dosimeter Gives Digital Readout Later

NEW YORK — Specialized radiation dosimeters, one of them a wide-range device based on the principle of thermoluminescence, and a flexible space photocell were among new products exhibited last week at the AIF-ANS Atom fair.

Dosimeters—Spokesmen for Con-Rad Inc., the thermoluminescent system's maker, said standard dose range is 100 mrad to 10^6 rad with linearity over the first five decades. This, plus an accuracy within 5 percent, makes it effective in medical applications, the firm says—such as in radiobiological studies of dose-rate effects or where other equipment would be unmanageable.

TLD's theory is this: crystalline material like phosphor can store some of the energy absorbed during irradiation, and when heated later, release it as light.

In use, encapsulated LiF phosphor is exposed at the point where dose measurement is desired. The material is poured into a planchet, heated 10 seconds inside the read-out machine, and the visible light picked up by a photomultiplier. Voltage is collected on a polystyrene capacitor and then measured by

BURNPROOF LACING TAPE AT NO ADDITIONAL COST —FROM GUDEBROD

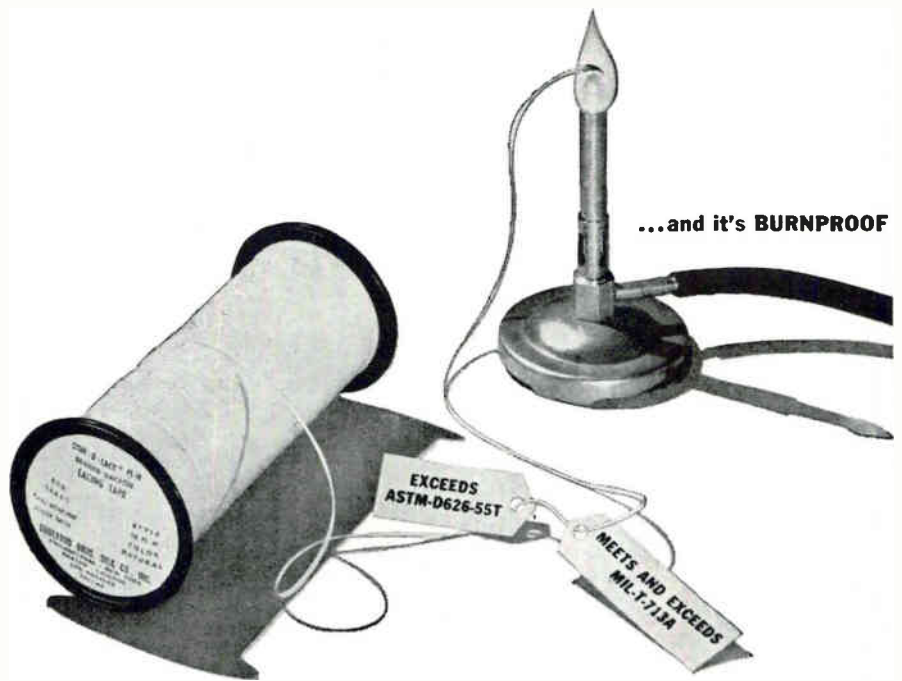

THE CABLE-LACER

increases worker efficiency by 25%



The first production tool available to ease, speed and improve the wire tying operation—producing tighter knots and more uniform harness.

Handle holds bobbin of cable lace, feeds as needed. Easily refilled. Eliminates handling long sections of tape, reduces splicing. Get your Production Department to investigate.

The specification of non-combustible materials in electronic equipment has, until now, required the use of special, higher priced lacings for harness tying. Through extensive work in their R&D Department, Gudebrod is producing two new burnproof lacing tapes—both available at no additional cost!

The first of their kind, these new tapes are made of Dacron* fibers and are flat braided for excellent handling and knotting qualities. In addition to meeting or exceeding all requirements for MIL-T-713A, the burnproofing exceeds ASTM-D626-55T.

Two types are being produced—Stur-D-Lace FLH, impregnated with a flame-proof fungistatic synthetic rubber finish, and Stur-D-Lace-R impregnated with a flameproof fungistatic vinyl finish. Both are essentially stable at -100° to 350° F. Neither will burn, but they will melt when a hot flame is applied. Each type is available in seven different strengths. Gudebrod Technical Product Bulletin #6 gives details.

The introduction of burnproof lacing tapes at standard prices represents another advancement in cable lacing practice by Gudebrod. The Gudebrod line of lacing tapes covers the entire range of wire harness tying requirements for both military and commercial equipment. Send for the Data Book on Gudebrod Tapes.

* "Dacron" is Du Pont trade name for its polyester fiber.

GUDEBROD BROS. SILK CO., INC.
FOUNDED IN 1870



Electronics Division

12 SOUTH 12TH STREET, PHILADELPHIA 7, PENNSYLVANIA

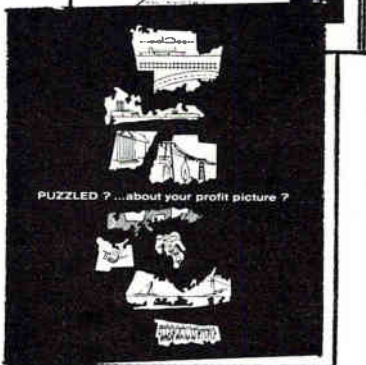
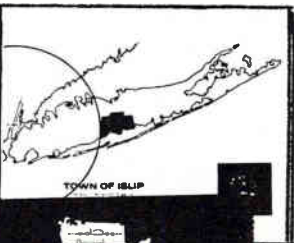
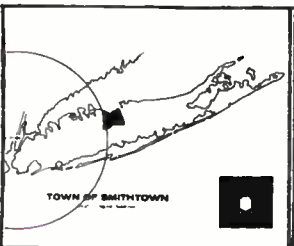
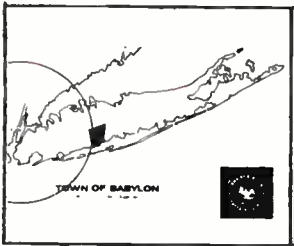
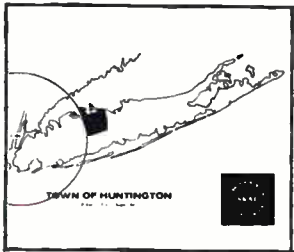

THERE'S ONE FOR YOU... in SUFFOLK'S Ten Towns

Inside the cover of this colorful, 44 page INDUSTRIAL FACT FOLDER (shown here) is EXACTLY the town you've been looking for. The town with ALL of the industrial assets you want and need. Write today for your FREE copy of this exciting FACT FOLDER. Just write to:

Commissioner John H. Stevenson
SUFFOLK COUNTY DEPARTMENT
OF COMMERCE AND INDUSTRY
1135 Old Walt Whitman Road
Melville, N. Y. • 516 HA 7-2540

an electrometer tube for digital read-out within 15 seconds.

A personnel alarm dosimeter, manufactured by Nuclear Corporation of America, is a military design transistor instrument that differs from rate-type devices by measuring total accumulated dosage. It gives users an aural alarm when factory-set dose limit is reached, and can be connected by wire to a remote alarm 100 feet distant.

The 2½-pound device operates 40 hours on two D cells. Detector is an argon-filled recycling ion chamber

in which current is produced to charge a capacitor. Capacitor discharge triggers the digital register calibrated in roentgens. Accuracy, the firm says, is ± 20 percent of true dose.

Solar Cell—A prototype cadmium-sulfide thin-film photovoltaic cell, designed for Air Force and NASA space vehicles, was displayed by Harshaw Chemical Co. Flexible to 90 deg on a 1-inch radius, the device supplies 13 watts per pound and is radiation resistant. Firm says it is not yet available commercially.

Repeater System All R-F

Novel heterodyne design handles microwave signals at r-f, doesn't use i-f

DALLAS—One-of-a-kind, 6 to 8.4-Gc, heterodyne repeater microwave system being completed by Collins Radio will transmit 1,800 voice channels, data or video signals over a 200-mile net in Formosa. Expansion to four frequency-diversity channels could handle a total of 7,200 circuits.

Although checkout of the system has been successful, the company reports it is so complex and testing so complicated, they do not intend to build any more. Parametric amplifiers, special twt's and solid-state circuits are used in the design.

All R-F, No I-F—The system is all r-f. Loss-reducing repeater stations receive, translate the frequency by 252 Mc, and retransmit signals without reducing frequency to i-f. The receiver terminal also demodulates at microwave frequencies—bypassing i-f.

A klystron in the transmitter terminal drives a special twt (which uses periodic permanent magnet focusing) to deliver 5 watts output with 37-db minimum gain at 26-db noise figure.

The through repeater is believed to be the first application of parametric amplifiers as input amplifiers for a commercial microwave communication system. It uses three stages of solid-state varactor diodes

pumped by a 12-Gc signal.

This section is followed by a twt amplifier and a microwave power leveler. A final twt boosts output power to 5 to 7 watts.

Receiver—Receiver input includes a three-stage parametric amplifier. Intermediate and final twt's, a power leveler and a final microwave power limiter are followed by a discriminator that requires about 1 watt of power. The balanced-waveguide discriminator demodulator uses waveguide filters as tuned circuits.

High performance horn reflectors, or parabolics with side-lobe suppressor shrouds, are required to allow this shf system to exploit its spectra efficiently, according to Collins.

Primary power source is 24 vd-c, from a float-charged battery plant. The transmitter terminal requires 80 amp, the through repeater 115 amp. Repeaters with drops require 146 amp.

LOW-COST GYROS

FARMINGDALE, N. Y.—Goal of gyro research is cost reduction by a factor of 5 or 10 and equivalent performance improvement, compared to classical inertial sensor designs. That was one of the few bits of information released last week after a classified symposium on unconventional inertial sensors, at Republic Aviation. Arma, for one, saw nonfloated free gyros as a "breakthrough in cost"

HOW TO USE YOUR ELECTRONICS BUYERS' GUIDE*

The Two-Way Product Locator



Most products advertised in the ELECTRONICS BUYERS' GUIDE are listed twice for your convenience. After the Product Heading, advertising page numbers appear where appropriate (when advertisements of one kind are grouped together in the book). Next to the individual product listing, the page number of associated advertising material is cited. Thus you can locate all of the advertisements for a particular product category, or any specific advertisement, quickly, accurately, and conveniently. Keep your ELECTRONICS BUYERS' GUIDE close to your work area at all times.

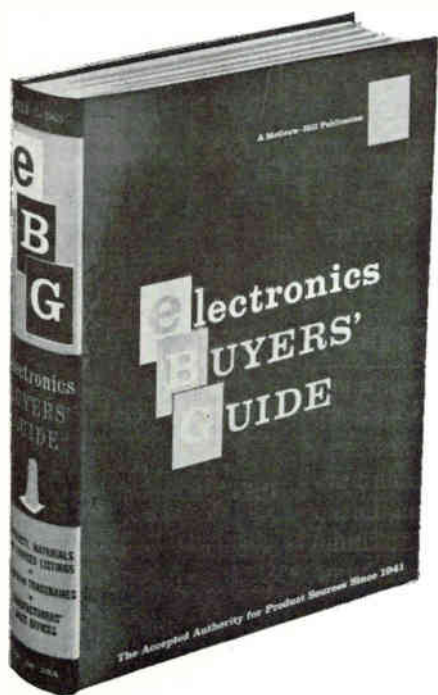

Eliminate Vibration Mount Failure Design with Cable Isolators DIRECT FROM STOCK



Design shock and vibration protection right into your system. Unique guide gives all information necessary to meet and exceed MIL specs. Design it with the Ladder Isolator Design Guide. Send to Dept. RB-31 for your free copy.



AEROFLEX LABORATORIES
INCORPORATED
South Service Road, Plainview, L. I., New York
(516) MYrtle 4-6700

CIRCLE 43 ON READER SERVICE CARD

Planning to change your address?

Use the form below to indicate a change of address. Because our issues are addressed in advance, please try to allow at least 5 weeks for change of address to become effective. Attach the address label from your most recent issue in the space provided below.

(Please print the following information for proper service)

Title or position.....

Name

Chief Job Responsibility.....

Distributor
Manufacturer

Company and Div.....

Product or Service Approx. No. of Employees

Address

City Zone..... State or Prov.

Mail to home address below:

Address

City Zone..... State or Prov.

Mail to: Fulfillment Manager, electronics
330 West 42nd Street, New York City 36, N. Y.

***Paste present mailing label or address
from wrapper or envelope here.**

New Field Effect Device May Aid Integrated Circuit Design

High-field triode has single junction, output resistance exceeds 1 megohm

By **MICHAEL F. WOLFF**
Senior Associate Editor

HIGH-FIELD TRIODE reported at the IEEE Electron Devices Meeting (p 10, Nov. 8) may add a new degree of flexibility to integrated circuit design. The experimental device is a planar silicon triode that resembles the metal-oxide-semiconductor (MOS) transistor yet differs in several respects: It has only one junction, it operates on positive gate voltage, and pinch-off doesn't obey the ordinary field-effect device relationships.

This was described by H. C. Nathanson, J. R. Szedon and N. A. Jordan, of Westinghouse Research Labs, Pittsburgh.

The high-field triode and the regular surface-controlled oxide unipolar transistor (a name Westinghouse Electric prefers for MOS transistors) are shown in the illustration. In operation, the p^+n junction of the high-field triode is reverse biased and an electric field of the order of 10^6 volts per cm is applied to the gate. The gate voltage, which is positive with respect to ground, serves to pull electrostatically large numbers of electrons to the surface of the n region. The resulting current flow is tentatively believed due to tunneling through the raised barrier at the p^+n junction. This differs from the SCOUT, where the junction barrier is lowered and holes are drawn to the surface.

Several factors point toward internal field emission, or tunneling,

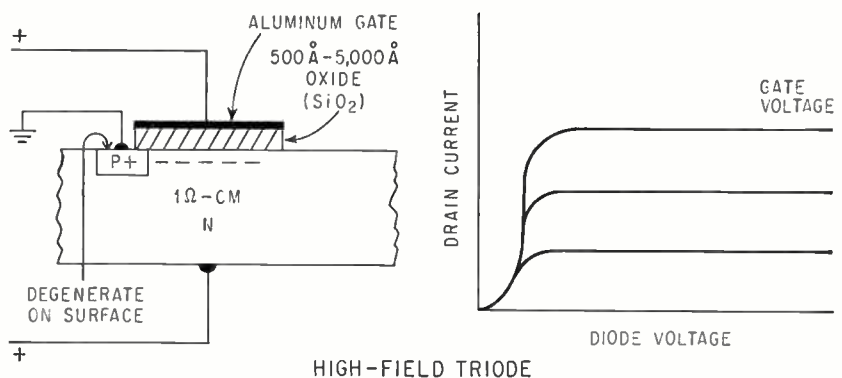
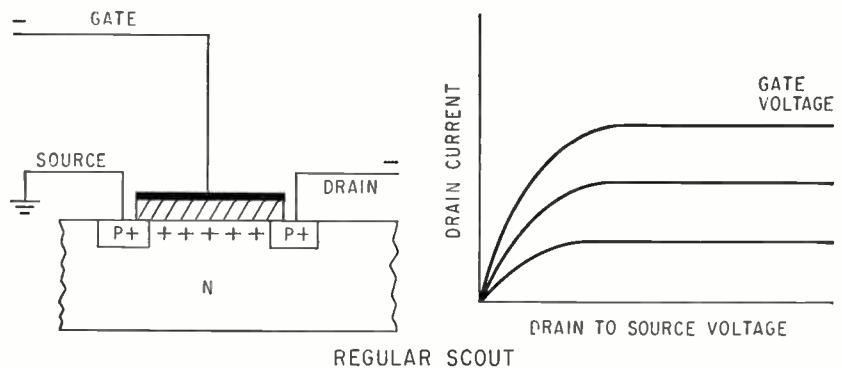

COMPARISON OF regular Westinghouse surface-controlled oxide unipolar transistor (SCOUT) and high-field triode

as the mechanism of current flow: 1) gate control is not observed if the p -region is nondegenerate, 2) fields in the oxide necessary to initiate current in the diode exceed 10^6 volts per cm, 3) the current is essentially temperature-insensitive, exhibiting a slight negative temperature coefficient, and 4) an exponential rise of diode current with oxide voltage is observed.

Characteristic — When potentials of a few volts are applied across the junction, a V-I characteristic similar to that of a reverse-biased tunnel diode is observed. At higher voltages the diode current saturates much more sharply than in the SCOUT, yielding a pentode-like characteristic. This apparent

“pinch-off” is not well understood at present. For a periphery of 10 mils, typical output resistances exceed 10 megohms, open-circuit voltage gains exceed 200 and g_m 's are 80-100 μ mhos. Larger devices have been made with g_m of 5,000 μ mhos and voltage gains greater than 300.

Since gate current is negligible (less than 10^{-12} ampere), the high field triode may be promising for integrated nanowatt logic circuits.

As indicated in the illustration, changes in gate voltages in the SCOUT produce equivalent changes in the pinch-off voltage. In the high-field triode, however, changes in gate voltages are reflected only slightly in pinch-off voltage changes. Because of this, more of the device

KEPCO

REGULATED **WR** DC SUPPLIES



POWER SUPPLIES WITH EXPERIENCE

The WR Group includes eleven time-proven models from Kepco's current production of 230 standard models. Kepco's representatives in your area can supply you with complete technical information, application ideas, and delivery.

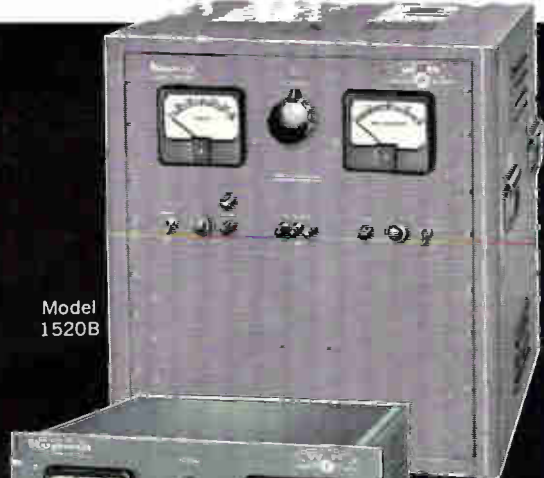

Model 1520B



Model 605



Model 430D

APPLICATIONS:

- ELECTROPHORESIS ■ RADAR
- ELECTROCHEMICAL PROCESSES
- MICROWAVES ■ PHOTOMULTIPLIERS
- COMMUNICATIONS-TELEVISION
- TELEPHONE SYSTEMS
- ELECTRO-MECHANICAL DEVICES

GENERAL SPECIFICATIONS:

- Input: 105-125 VAC 50-65 cps single phase
- Operating Temperature: -20° C to +55° C
- Temperature Coefficient: <0.01% per °C
- Recovery Time: 50 microseconds
- Isolation: 400 volts (except HB 2050)
- Meters: Voltmeter and Ammeter
- Convection Cooling
- For Relay Rack or Bench Use
- Multiple output and high voltages
- Plate, Grid and Heater Voltages
- Continuously Variable, Zero to full output

See our Complete Catalog in



MODEL	DC OUTPUT RANGE		REGULATION				RIPPLE RMS MV	AUX. OUTPUT 6.3VAC Unregulated	PRICE
	VOLTS	MA.	LOAD O-MAX %	LINE %	ΔV	ΔV			
2400 B - #1	0-150	0-5	*	*	*	*	1		\$540.00
#2	0-400	0-150	0.025	0.1	0.1	0.4	3	10 AMP	
#3	0-400	0-150	0.025	0.1	0.1	0.4	3	10 AMP	
400 B	0-400 0-150	0-150 0-5	0.025 *	0.1 *	0.1 *	0.4 *	3 1	10 AMP	270.00
430 D - #1	0-450	0-300	0.025	0.1	0.1	0.4	3	10 AMP	675.00
#2	0-450	0-300	0.025	0.1	0.1	0.4	3	10 AMP	
800 B - #1	0-600	0-200	0.02	0.1	0.1	0.4	3	10 AMP	575.00
#2	0-600	0-200	0.02	0.1	0.1	0.4	3	10 AMP	
605	0-600 0-150	0-500 0-5	0.02 *	0.1 *	0.1 *	0.4 *	3 1	20 AMP	425.00
615B	0-600 0-150	0-300 0-5	0.02 *	0.1 *	0.1 *	0.4 *	3 1	10 AMP	355.00
1250 B	0-1000	0-500	0.01	0.1	0.05	0.4	3		650.00
1220 C	0-1200	0-50	0.01	0.1	0.05	0.4	3	10 AMP	465.00
1520 B	0-1500	0-200	0.01	0.1	0.05	0.4	3		695.00
HB 2050	0-2000	0-500	0.005	0.1	0.02	0.4	3		1565.00
HB 2500	0-2500	0-50	0.005	0.1	0.02	0.4	5		975.00

*0-150V bias - Regulation : 0.01% Line / 2% Load at 150V

For complete specifications on more than 230 standard model Power Supplies, send for NEW Catalog B-631.



131-38 SANFORD AVENUE, FLUSHING, N.Y. 11352 • Phone: (212) IN 1-7000 • TWX #212-539-6623 • Cable: KEPCOPOWER NEWYORK

CIRCLE 45 ON READER SERVICE CARD

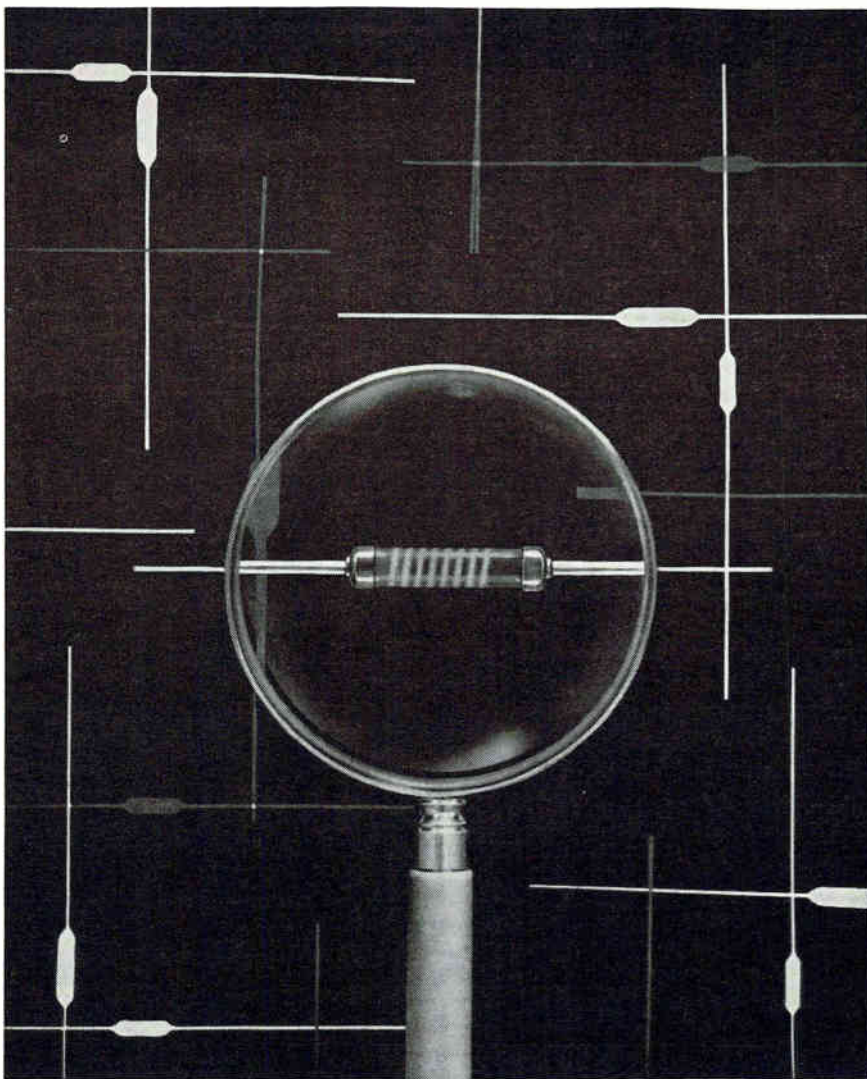

New: a smaller, tougher METOHM with rugged end-cap construction

New 1/10 and 1/8 watt conformal-coated metal film resistors exceed requirements of MIL-R-10509D, characteristics C,D,& E

Ward Leonard's new Type WLC 55 & 60 METOHM® precision resistors mark a new reliability high in the components industry.

Gold-plated end-caps and gold end-terminations for lowest contact resistance, precision tolerances, low T.C.'s, and high stability make the Type WLC METOHMS ideal for critical applications in ratio dividers, timing circuits, measuring instruments, and circuit modules. For extreme miniaturization, you get double the wattage rating at an operating ambient temperature of 70°C.

Write for specifications and/or evaluation samples. Our Hagerstown, Md. plant now has double capacity—devoted exclusively to metal film precision resistors—means faster deliveries. Ward Leonard Electric Co., 30 South Street, Mount Vernon, N. Y. (In Canada: Ward Leonard of Canada, Ltd., Toronto.)

4.5

WARD LEONARD



METAL FILM DIVISION

characteristic is available for linear amplifier design and it may allow using lower-voltage power supplies.

Present understanding of the operating mechanism indicates the active area of the high-field triode is small, probably of the order of a depletion width of the diode, and typically $\frac{1}{2}$ micron or less. Thus, low input capacitances should be possible. At present non-optimized geometries have yielded rise times of about 100 nsec.

Because the high-field triode is a single-junction triode while the regular SCOUT requires both a source and drain junction, simpler integration of semiconductor blocks may be possible. Also, the gate area can theoretically be made small since there is no source-to-drain distance to control.

While the device is still experimental, fabrication involves the same steps as in ordinary planar transistor production and high yields have been observed. Although gate voltages are as high as 60 v, a new fabrication technique is being developed that allows operating at less than 14 v. There are still reproducibility problems associated with this technique, however.

Injection EL Device Emits At 5,000 Å

POLISHED cadmium sulfide (CdS) crystal, doped with 0.003 percent of indium chloride (InCl_3) forms the injection electroluminescent device shown on the cover. The crystal is a rectangular parallelepiped about 20 by 20 by 50 mils in size, mounted on a TO-5 transistor header by Westinghouse researchers.

The crystal is attached to the header with indium metal, making an ohmic contact to the cadmium sulfide. A metal-to-semiconductor rectifying barrier contact is made to the top of the crystal by thermo-compression bonding a two-mil gold wire to the CdS. The contact is surrounded by conducting silver paint to improve the efficiency of hole injection into the crystal.

Under forward bias of about one volt, injection occurs and recombination radiation is emitted. The peak intensity of the radiation is at 5,000 Å. With doping materials

other than indium chloride, the radiation wavelength can be shifted as far as 5,250 Å.

Transducer Gets FM From Mechanical Displacement

TRANSDUCER developed by ITT's Federal Electric converts mechanical motion directly into frequency-modulated signals. Input torque is applied to the center of a twisted ribbon, causing half of the ribbon to untwist and the other to twist tighter. Each half of the ribbon is vibrated electromagnetically, and the torque increases the resonant frequency of one-half the ribbon and decreases the resonant frequency of the other half.

The device, according to an ITT spokesman, is useful whenever extremely accurate direct conversion of sound waves or angular motion to f-m signals is required. Power consumption is less than half a microwatt, threshold is infinite, and accuracies of better than 3.2 seconds of arc have been reported in measuring angles.

Helium Cools Paramp

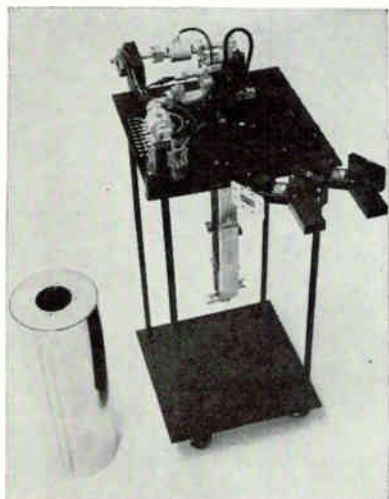

TWO-STAGE X-band parametric amplifier assembly, designed by MIT's Lincoln Laboratory for the Haystack radar system, can be cooled with either liquid helium or liquid nitrogen. Dewar flask, bottom left, is removed to show the two paramp stages developed by Texas Instruments, Inc, at bottom of vertical waveguides. Four-port circulators, projecting at right, separate input and output connections; cooled section of assembly can be evacuated or backfilled with helium gas

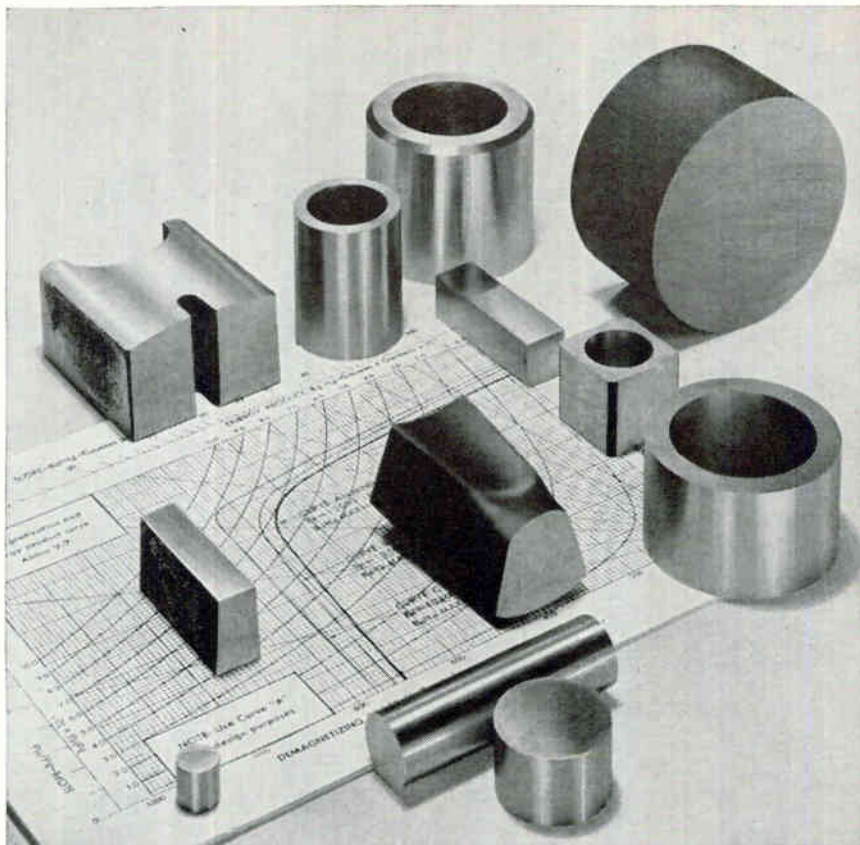

SEVEN IS YOUR LUCKY NUMBER TO REDUCE SIZE AND WEIGHT IN ALNICO V DESIGNS

ARNOLD ALNICO V-7 permanent magnets may be just what you're looking for to realize important weight reductions in current Alnico V designs, without loss of energy. This higher-energy material has a maximum energy product of 7.0×10^6 or more, compared to 5.25×10^6 generally used for Alnico V.

This figure of 7.0×10^6 is a minimum value for our production of Alnico V-7, and is used for design purposes. The unique properties of this premium material are secured by achieving almost 100% columnar crystal orientation during processing. In actual Arnold production, a typical energy product of 7.5×10^6 is realized; and where 100% orientation is secured, the BdHd product attains a value as high as 8.97×10^6 . The limitation occurs in the physical shape of the magnet, and the relationship of cross-section to length.

Alnico V-7 permanent magnets are available in quantity from Arnold to meet your production requirements, and your specifications as to size and shape. A typical group is illustrated above.

• For more information, write for Bulletin PM-123—and let our engineers assist you by evaluating your existing assemblies or proposed designs to determine the advantages you can secure with Alnico V-7.

277-R1A

ADDRESS DEPT. E-11-2



ARNOLD

SPECIALISTS in MAGNETIC MATERIALS

THE ARNOLD ENGINEERING COMPANY, Main Office: MARENGO, ILL.
BRANCH OFFICES and REPRESENTATIVES in PRINCIPAL CITIES

Diodes Tolerate High Radiation

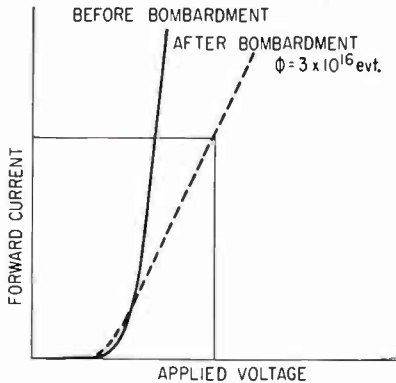

HOW increasing radiation flux affects forward resistance, Fig. 1

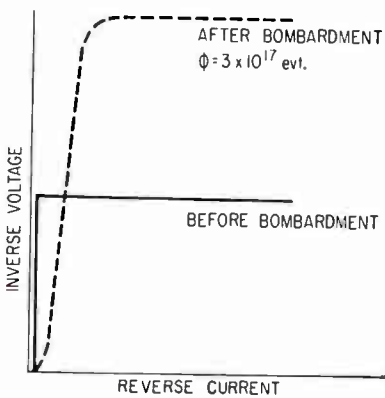

BEHAVIOR of diode's reverse characteristics under electron bombardment, Fig. 2

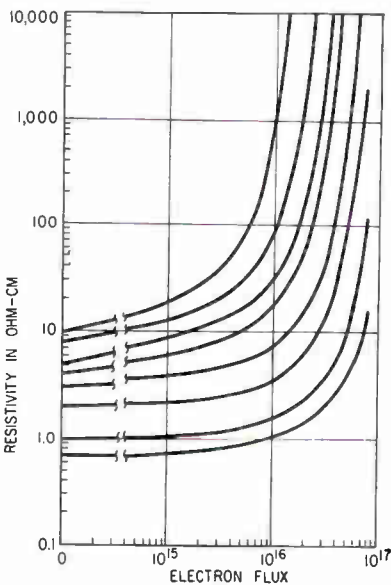

RESISTIVITY change of n-type silicon under irradiation, Fig. 3

Improved materials combine low capacitance with fast switching speeds

By **DAVID NAVON**
Transitron Electronic Corp.,
Wakefield, Mass.

DIODES with excellent electrical characteristics can be used today in nuclear environments without concern for circuit malfunction due to drastic changes of device characteristics.

A five year program in fundamental research and design of radiation resistant devices at Transitron has led to a series of diodes having 100-volt junctions capable of withstanding 10^{15} to 10^{16} nvt. These units have capacitances of 1 to 2 pf and switching speeds of 2 to 4 nano-seconds.

A similar program is planned to improve the radiation tolerance of transistors and controlled rectifiers. The hope is that complete solid-state circuits, especially suitable for space applications because of light weight and reliability, can be made to perform reliably in significant nuclear and space environments.

Generally, the diode parameter which degrades most readily under nuclear and space irradiation is the diode forward dynamic resistance. At a given current level in the diode forward direction, the potential drop across the device increases with increasing radiation flux, Fig. 1. At a still higher flux level, the diode reverse leakage will increase in general, but the avalanche breakdown voltage will improve. Typical behavior of the diode reverse characteristic is shown in Fig. 2. An interesting fringe benefit of nuclear

radiation is a diode with a faster pulse recovery.

Above and beyond the basic design considerations, the diode resistance can be increased several hundred percent by using silicon starting material with improved radiation tolerance.

Factors affecting the change of resistivity of silicon under nuclear bombardment have been found to be different in *n*-type and *p*-type silicon. The radiation resistant materials program has ascertained that the carrier removal rate in *p*-type silicon increases in proportion to the number of acceptor impurities present in the material. For *n*-type silicon, it was confirmed that increased oxygen content meant more silicon radiation resistance.

This program was aimed at increasing the quantity of oxygen in *n*-type silicon. Special additives in Czochralski-grown crystals can increase the oxygen content several fold. A continuing program, aimed towards more radiation tolerant silicon, is in progress and improvements are still to be made. The change of resistivity of *n*-type silicon containing special additives, caused by electron flux as high as 10^{17} electrons/cm² is illustrated in Fig. 3. It is this resistivity that degrades the diode forward impedance under irradiation.

As the first step in device design, tentative electrical specifications for the diode, before and after exposure to a given electron or neutron flux were drawn up spelling out such parameters as peak inverse voltage, inverse leakage, maximum forward voltage drop at a set forward current level, maximum avalanche current, maximum pulse recovery time, and maximum power dissipation permitted. Then a basic design was postulated and silicon starting material, epitaxial or Czochralski, was chosen. Diffusion profiles were calculated, often with a computer. Sample devices were constructed

and tested for radiation tolerance with the aid of a Van de Graff accelerator, and finally manufacturing specifications were drawn.

Two-Third Inch Vidicon Meets Tv Standards

TOKYO—Matsushita electric industrial company has developed a 2/3-inch vidicon with 500 line resolution. Company says tube conforms to commercial tv broadcast standards. Signal of 20PE11 is comparable to one-inch vidicon. Unit weighs 300 grams, has maximum diameter of 19.5 mm, overall length is 105 mm. Sectional area of coil assembly is 45 by 45 mm.

Company says an entire camera can be built in the volume occupied by an 8-mm movie camera. Standard 8-mm movie lens can be used for economy. Inexpensive, standard, seven pin sockets of portable tv sets can be used.

Forged Shield is Stronger

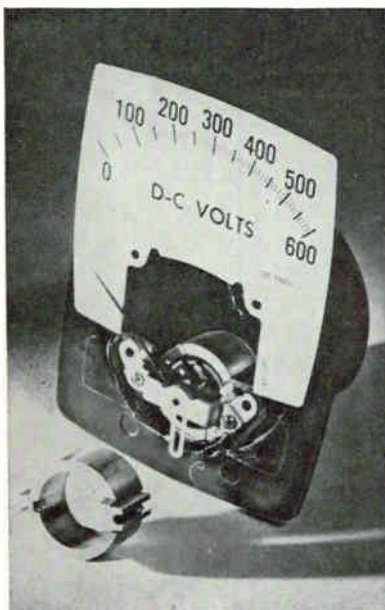

POWDER METALLURGY panel meter shield is "forged" for greater strength. That is, the component is repressed in the original dye, which may be considered a "die forging" operation. The shield is then spray-painted with aluminum for atmospheric protection

LOW COST??
FASTER!
more!
reliable!
smaller
tubeless!

NEW
 SOLID STATE
 CIRCUITRY
 CONCEPT...
 AND IT WORKS!

A new Dual-limit controller that sounds too good to be true

Design Engineer: "It does seem incredible, doesn't it? But I've seen it in operation and it really works! This new 'Ultra Comparator® Dual Limit Control' of Carter-Princeton's combines two 100 K input impedance comparators on one small size, computer-type, plug-in circuit card . . . it provides 4 sets of relay contacts per comparator . . . and it has the fastest power relay output achieved yet."

Management: "What is the speed, exactly?"

Design Engineer: "Only 5 milliseconds from signal to full 2 ampere output, and it's sensitive to 3 millivolts."

Management: "Where do you need that much speed and sensitivity?"

Design Engineer: "One present application is control of a rocket engine test stand, to shut down the equipment when critical parameters go outside rated limits. But it's also useful in alarm and check-out systems of many kinds—any place where you need band limit controls in multiples of two for any reason."

Management: "How about cost?"

Design Engineer: "That's another surprise—anywhere from 25% to 50% lower than any comparable unit, largely because of a new Carter-Princeton concept in circuitry. It does away with about half the transistors and two-thirds of the parts that would otherwise be required."

Management: "If it's all that good, I'm right with you. Let's give it a try!"



The Model 2020 circuit is one of a series of new Ultra-Comparator® units offering high sensitivity, compactness, reliability and adaptability at substantial savings. A limited number are available on free loan for trial. For details, contact Carter-Princeton, Electronics Division, Carter Products, Inc., 178-F Alexander St., Princeton, N. J., 08540. Phone (609) 921-2880.



CARTER-PRINCETON

What Makes a Solder Joint Good?

Metallurgy reveals why solder should be bright, thin and fine-grained

By J. D. KELLER
Advanced Mfg. Technology Martin Co., Orlando, Fla.

ENGINEERING logic rather than individual opinion is required to acquire firm visual standards of acceptable solder joints.

A solder connection on copper produces various discontinuities, dewets and stress lines. These flaws appear even if the base metal is gold plated. Solder-spread tests under controlled conditions establish the effect of these flaws on the reliability of a finished joint. We could, for example, assume that if solder balled up and did not spread, the solder and base metal were not compatible. Various spread tests have shown that a solder bond is more mechanical than metallurgical.

Applying this information to actual solder joints, these discontinuities are seen in soldered connections on gold-plated printed-circuit boards. Where lack of smoothness, brightness and conformally covered joints are observed, we can assume that compatibility is lacking between the solder and the gold-plated base metal. Examination shows gold actually amalgamates with the eutectic solder forming an alloy with

a different surface energy. Thus to obtain a quality solder joint on a gold-plated printed circuit board, it becomes necessary to wick off old solder and resolder to get smooth, bright joints with a good metallurgical bond.

Joint Brightness—Bright joints result when solder is free of gas entrapments and properly solidifies. In dip and flow soldering, solder quickly absorbs oxygen and forms large grains. To retain fine solder grain, strict thermodynamic controls are needed. Fine-grain solder joints, while defining joint quality, basically indicate material purity and control during solidification. A fine-grain joint must be chilled quickly to be bright. In a normal chill, columnar grains are apparent. A coarse-grain joint lacks strength. Large grains form toward the center of the joint and near its crater.

The term "cold joint" usually refers to a crystalline gray formation. Most inspectors blame this on lack of heat. Studies prove it is the result of prolonged heating. Joints should be both formed and solidified rapidly, preventing absorption of excess heat. A dark appearance is usually due to coarse grains and can be caused by amalgamation with the base material. This is usually true of joints on gold-plated surfaces.

Foreign Material—An important criteria in contour soldering is a proper dihedral angle of wetting.

This is directly related to solder flow and the condition of the base metal. To control the angle, a chemically clean surface is required.

Base-metal surface preparation is more important than plating. Plated surfaces induce sorption. Gases such as H₂, CO, O₂ and water vapor present problems. Apparently, absorption on the surface allows impurity atoms to be imbedded into the crystalline lattice of copper. The interaction between metal and gas can form a new nonmetallic compound. This in turn, dewets and affects the base-metal surface-energy control enough to prevent good spreading.

Wetting Angle—The dihedral angle of wetting is an index of interfacial conditions between the solder and the base metal. It helps determine joint integrity. As attraction between solder and base metal increases, smaller dihedral angles are seen. Solder placed on a gold-plated, or improperly prepared copper surface, may show an 80-degree angle. On a properly treated copper surface, the angle is small. Thin solder coating indicates that the solder flowed on a chemically clean surface under balanced thermodynamic conditions with high molecular attraction between solder and base metal to assure a metallurgically completed bond of high reliability.

Material factors such as hardness, alloy, time, topography, atmosphere, solubility, surface condition, tem-

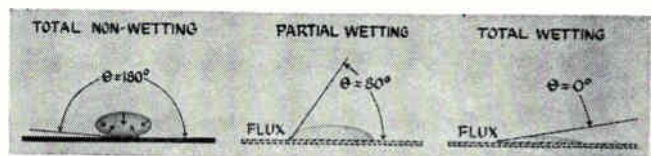
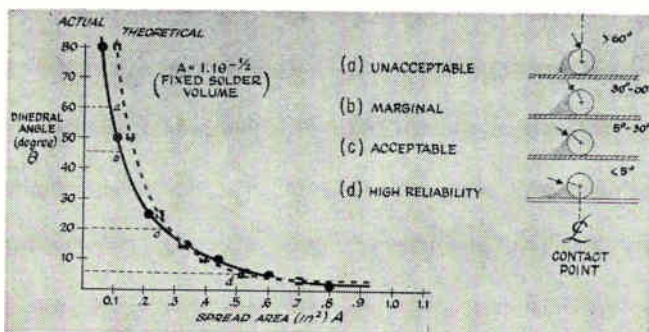

DIHEDRAL ANGLE approaches zero in ideally wetted joint and spread area increases. Limits of four levels of grading are indicated (left)



TINNED COPPER interface magnified 1,000 times. Intermetallic layer assures joint reliability

perature and form tend to distort the sample joint used for comparison so that it is of little use in evaluation. When the wetting area to dihedral angle concept is used, holding the above variables constant with the exception of form factor, a relationship can be established (see curve). Dihedral angles of over 30 degrees indicate marginal wetting, while angles of 5 to 30 can be considered acceptable for certain applications: angles that are below 5 degrees are required for highest reliability. On well prepared surfaces, solder fillets tapering to the base metal with contact angles approaching zero are not uncommon.

Intermetallic Formation—The completeness and reliability of a solder joint are controlled by the intermetallic compound formed when eutectic solder combines with the base metal. This new material and its thickness are basic requirements of a successful connection. In many instances they establish reliability.

Strength—While soldering is not performed for strength alone, it is necessary to assure reliability of electronic connections under various environmental conditions. Pull tests performed by the Army Ballistic Missile Agency at Huntsville, Alabama, have proven that solder joints formed on a copper surface are stronger than those on gold-plated surfaces. Solder-joint strength depends on the base metal and its preparation. For example, greater strengths are realized when copper surface has been nickel-plated (with or without a gold overlay to prevent oxidation). But while these surfaces yield higher strengths, other problems are developed. Spread tests have indicated that nickel-plated surfaces, with or without gold overlay, give a spread factor of approximately half of that of a properly prepared copper surface or a solder-coated copper surface.

New ac-dc laboratory standard



Speed voltmeter calibration Simplify supply voltage monitoring

±0.03% accuracy of indication. Engelhard's new Differential Thermocouple Voltmeter provides features never before available in a single instrument. Model 35700 DTVM is designed for rapid, high-precision voltmeter calibration, monitoring of supply voltages, and is ideal for critical ac and dc measurements as well. The instrument offers an accuracy of ±0.03% at any voltage from 1 to 1011.1v—either dc or 5cps to 1kc. Accuracy is rated as percent of *actual* reading rather than full-scale deflection.

Model 35700 indicates results directly, without multiplying factors or calculations, and requires only one operation per calibration reading. In addition, all measurements are performed without accessory equipment.

Circuitry is based on a similar design developed by Griffin and Hermach for the National Bureau of Standards. Calibration of the instrument is traceable to NBS, and the DTVM is acceptable for certification by the Bureau.

Exceptional stability permits uninterrupted observation of voltage changes as small as 0.02% over a period of several hours. Zener diodes establish a precise basic reference voltage, while a balanced thermal-converter circuit cancels effects of ambient temperature variations.

Simplified operation speeds measurement and helps eliminate error.

Calibration and monitoring results are indicated directly in *percent* on the DTVM. Voltage readings appear directly in *volts* on the instrument.

SPECIFICATIONS

Range (ac-dc):
Accuracy (±0.03%):
Accuracy (±0.05%):

1 to 1011.1, with overranging
dc and ac from 5 cps to 1 kc,
any voltage rating.
1.0 to 600v (1kc to 30kc)
600 to 800v (1kc to 20kc)
800 to 1011.1v (1kc to 10kc)
19 x 19 x 9
105/125v, 60cps, 10w

Size (inches):
Power requirement:

Write Engelhard for details on Model 35700 DTVM. We'll send a technical data sheet with full information and specifications.



Oscillators Exhibit High Stability

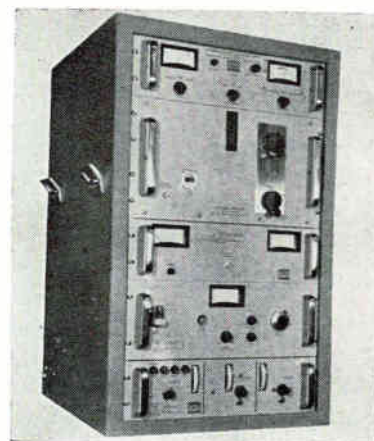
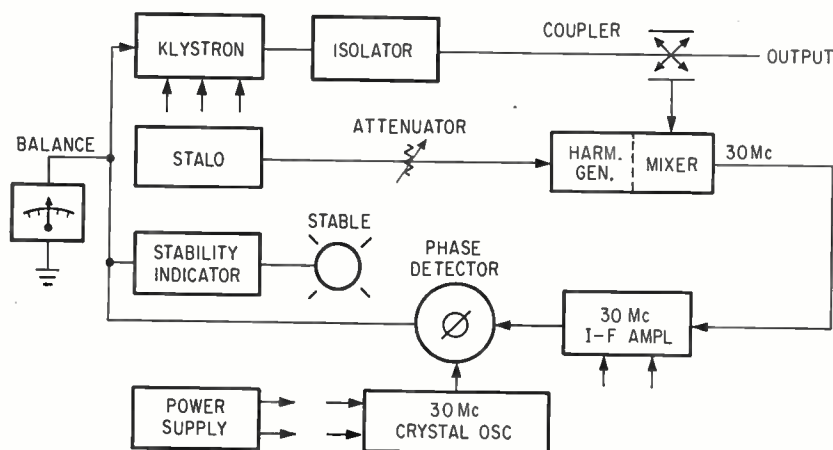

Units cover 17.5 Gc to 100 Gc with stability of 1 part in 10^9

SERIES of ultrastable oscillators extends the frequency range of precision signal sources from K-band to 100 Gc. System consists of the manufacturer's standard stalo, a millimeter-range oscillator and power supply, and a klystron synchronizer unit. Where maximum stability is required, the stalo reference may be replaced by a crystal oscillator reference with a short-

term stability of 1 part in 10^9 .

In operation, the desired reference frequency is obtained by selecting a harmonic of a lower-frequency signal source such as an ultrastable oscillator or crystal oscillator and harmonic generator unit. The millimeter klystron output is isolated from loading effects by a ferrite load isolator and is applied to a directional coupler. A suitable sample is taken from the coupler and applied to one input of a harmonic mixer. The desired output frequency is mixed with a harmonic of the reference to produce a 30-Mc difference frequency that is ampli-

fied and compared with a 30-Mc reference. This produces an error signal proportional to the phase difference between the two 30-Mc signals. The error voltage is applied to the klystron reflector, thereby providing phase synchronization.

Applications include local oscillators for coherent radars, calibration of signal generators, energy source for microwave spectrometers and electrical testing of microwave components. Frequency Engineering Laboratories, P.O. Box 527, Farmingdale, N.J.

CIRCLE 301, READER SERVICE CARD

Diode Arrays Are Gate-Core Drivers

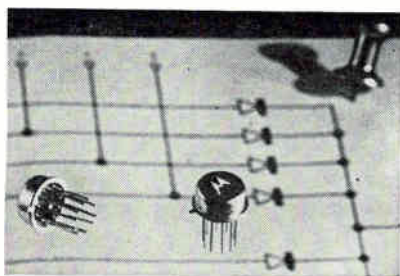

THREE multiple-diode devices, incorporating up to 16 interconnected silicon diodes in a single package are designed to be utilized as gate-core drivers in computer memories.

Packaged in 10-pin TO-5 cans, multiple-diode gates type MC1116 and MC1117 contain 9 diodes with common anode and common cathode connections respectively. Type MC1118 consists of 16 diodes connected in a series-parallel matrix.

Multiple diode units reduce circuit-board space requirements by 31% and weight by 78% in comparison with banks of individual diodes. Other advantages include reduction of wiring connections, handling and the elimination of reverse-polarity connection problems.

Each diode has a 40-volt reverse breakdown rating and a maximum

forward voltage drop of 1.2 volts at 300 ma. Maximum reverse recovery time is 90 nsec. Units are priced at \$19.40 each for types MC1116 and MC1117 and \$34.40 each for type MC1118. Motorola Semiconductor Products, Inc., P.O. Box 955, Phoenix, Arizona. (302)

Pulse Generator Has Low Jitter

DUAL-CHANNEL 4-pulse generator can deliver between 25 and 4,000 pps at amplitudes adjustable from



0 to 10 volts into 100 ohms. Unit has four output pulses, both a positive and a negative in time coincidence from each of two channels.

Model 7032 offers fast, virtually jitter-free performance with rise times of less than $0.03 \mu\text{sec}$ and jitter below 0.02-percent, $\pm 0.01 \mu\text{sec}$. Pulse-pair widths of each channel can be individually varied from $0.1 \mu\text{sec}$ to $1,000 \mu\text{sec}$. Delays are individually variable from $0.1 \mu\text{sec}$ to $10,000 \mu\text{sec}$. Independent coarse range controls, 10-turn continuous controls and vernier controls for each channel permit achievement of high pulse width and pulse delay resolutions.

Instrument provides automatic protection against output-pulse over-loads and will not be damaged by continuous short circuits on pulse outputs. Admiral Palo Alto, 901 S. California Ave., Palo Alto, Calif. (303)

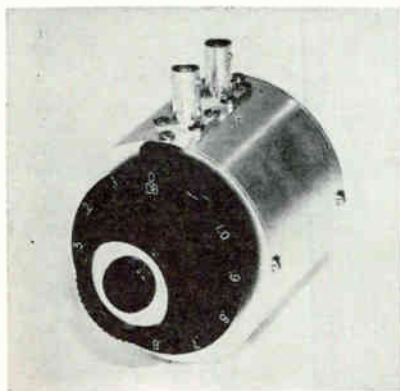

Attenuator Has Tenth DB Stepping

TURRET r-f attenuator has a full range of 1 db in steps of 0.1 db to provide precise attenuation. Unit uses resistive pi-pads mounted in a machined rotor assembly designed for optimum impedance matching. The pads themselves incorporate



NOW...you can choose magnetic circuit breakers...from stock!

New KLIXON miniature units . . . push-pull and toggle . . . are stocked at 8 convenient locations.

Freedom from design limitations and delivery delays are two reasons why leading companies are specifying KLIXON 2MC and 3MC Series Magnetic Circuit Breakers.

Design options provide freedom of choice in two areas: actuators and terminals. 2MC units feature toggle actuation; 3MC, push-button actuation. Both types provide visual warning of an overload condition — either by the position of the toggle or the exposed white band on the push button. You also have a choice of quick-connect, solder or screw-type terminals.

Other desirable features include: ratings from .050 to 15 amp at either 32 v-dc or 120 v-ac, 60 cycle; trip-free protection of circuits and equipment; trip response of 5 to 15 MS at 200% rating and endurance cycling of 10,000 operations at 100% rating.

Eight-point warehousing promises off-the-shelf delivery to all users of KLIXON Magnetic Circuit Breakers.

Bulletin DD-CIRB-28 gives complete specifications, design options and performance characteristics. Write for it and the name of the distributor nearest you today.



METALS & CONTROLS INC.

5011 FOREST ST., ATTLEBORO, MASS.
A CORPORATE DIVISION OF

TEXAS INSTRUMENTS
INCORPORATED

OPPORTUNITIES IN MELPAR'S RAPIDLY EXPANDING ELECTRONICS DIVISION

Melpar's Electronics Division has an immediate need for Engineers to fill these important positions:

MICROWAVE RECEIVER DESIGN

Specific problems include parametric amplifiers, varactor techniques, microwave filters, ultra-stable programmable oscillators, and dual and triple channel balanced receivers for monopulse and guard antenna gating.

DATA PROCESSING SYSTEMS DESIGN

Perform the logic design of digital equipment to process real time flight data. Problems include specifying necessary digital/analog interface equipment and the design of computer systems for a variety of applications.

COMPUTER PROGRAMMING

Generate programs for fixed point real time computers to be used with special purpose digital and analog equipment.

COMMUNICATIONS

Perform design studies of terminal equipments for time frequency dodging, matched filters, adaptive highly reliable communications throughout the electromagnetic spectrum. Techniques of interest include spread spectrum circuitry, error detection and correction coding, and privacy and security circuitry.

For Further Details,
write in confidence to:

John A. Haverfield

Manager—Professional Placement

MELPAR INC.

(A Subsidiary of Westinghouse
Air Brake Co.)

3436 ARLINGTON BLVD.

FALLS CHURCH, VA.

(A Suburb of Washington, D.C.)

an equal opportunity employer

low-tolerance resistors to maximize accuracy of circuit values. Pads are set in position between output and input connections by the rotor, with separate pads used for each attenuation value.

Attenuator operates between d-c and 900 Mc, has a 50-ohm input impedance and an insertion loss of about 1 db. At 30 Mc, the accuracy of the device is 0.02 db, and its vswr is 1.1:1. At 900 Mc, these ratings are 0.05 db and 1.3:1 respectively. Unit bears the designation TC-50. Telonic Industries, Inc., 60 North First Ave., Beech Grove, Indiana.

CIRCLE 304, READER SERVICE CARD

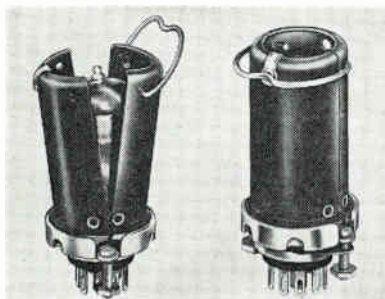

Tube Shield Reduces Heat to 75 Percent

MILITARY Type A tube shield puts no strain on tube contact pins, requires no torque or twisting to lock in place, puts no insertion force on the tube bulb and has no tendency to pull the tube from its socket when it is removed. The shield which is hinged at the base opens for easy insertion and removal. When in place over the tube, the shield is closed and secured by a metal snap-ring at the top. The interior of the shield is fitted with a glove-like grip to the tube and provides maximum heat dissipation to the tube shield case. Shield is available in sizes to fit tube sizes: T5-1/2 and T6-1/2, short, medium and long. Atlee Corp., 2 Lowell Ave., Winchester, Mass. (305)

Control Knob Eliminates Scoring

THE A-LINE-RITE series control knob is comprised of five basic parts: the cap, an O-ring, set-screw, collet, and the knob body. The cap is re-

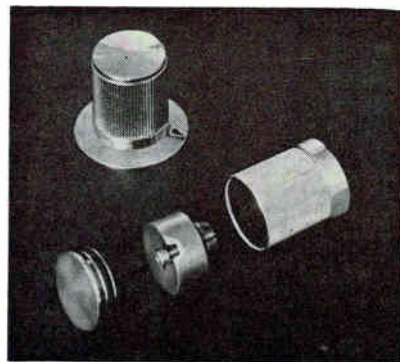

movable to provide access to the set-screw. The set-screw is positioned through the shoulder of the collet (the internal member of the knob assembly) and engages the underside of the knob body. When the set-screw is tightened, the tapered portion of the collet is forced into the chamfered portion of the knob body causing the split ends of the collet to compress thereby exerting pressure on the control shaft. The pressure thus exerted is uniform in all directions and is accomplished without scoring or in any other way marring the control shaft. Intended applications for the device are industrial test equipment, computers, telemetering equipment, and general communications equipment. Control Knobs, Inc., 335 Van Sicken Ave., Brooklyn 7, N. Y. (306)

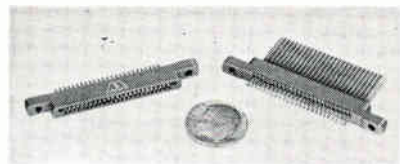

Tiny Connectors Designed for P-C Cards

MICROMINIATURE and picominiature connectors for printed-circuit cards are announced. These precision edge type connectors for miniaturized electronic packaging allow single or double sided p-c cards to be mounted perpendicular to the "mother" board. Utilizing durable formed contacts and rigid molding material, the new connectors are designed in sizes for 10 through 50 contacts that are center-to-center spaced at 0.050 in the microminiature and spaced at 0.025 in the picominiature. Winchester Electronics Inc., Willard Road, Norwalk, Conn. (307)

LITERATURE OF THE WEEK

HIGH-VOLTAGE RECTIFIERS General Instrument Corp., 65 Gouverneur St., Newark, N. J. A group of 10 bulletins describes a wide range of silicon and selenium h-v rectifiers for applications to 1,000,000 prv. (360)

REINFORCED PLASTICS The Connecticut Hard Rubber Co., 407 East St., New Haven 9, Conn. Brochure contains design considerations for fiberglass reinforced plastic parts. (361)

MAGNETIC DRUMS & DISKS General Precision, Inc., Burbank, Calif. A new line of random-access magnetic drums and disks is described in an 8-page illustrated brochure. (362)

T-W TUBE Watkins-Johnson Co., 3333 Hillview Ave., Stanford Industrial Park, Palo Alto, Calif. Technical bulletin deals with the WJ-276, an 8 to 12-Gc low-noise permanent-magnet twt with integral power supply. (363)

PIN DIODES Hewlett-Packard Co., 1501 Page Mill Road, Palo Alto, Calif. A 10-page Application Note discusses how PIN (positive-intrinsic-negative) diodes work as microwave modulators and attenuators. (364)

RFI FILTERS Hopkins Engineering Co., Box 191, San Fernando, Calif. Data log SK-109D describes a new line of dual circuit heavy duty rfi filters for power lines. (365)

PULSE AMPLIFIER TETRODE Calvert Electronics Inc., 220 E. 23rd St., New York 10, N. Y. Data sheet describes the English Electric pulse tetrode 4PR60WB for use in radar modulators. (366)

PRESELECTORS Micro-Beta Laboratories, Inc., 4900 W. Grand Ave., Chicago, Ill., 60639. Two-page catalog covers a line of economical general purpose modular preselectors which meet MIL-R-5400E, Class 2, Aircraft. (367)

FREQUENCY RESONATORS Accurate Instrument Co., P.O. Box 19426, Houston, Texas 77024. Two-page brochure describes a new series of pico-miniature frequency resonators which offer a stable frequency source at extreme environmental conditions. (368)

RELAY SPECIFICATION Filtors, Inc., East Northport, N. Y. Amendment 2 of MIL-R-5757D which makes important revisions and additions to the basic relay specification has been made available in reprint form. (369)

WELDING WIRE All-State Welding Alloys Co., Inc., 249 Ferris Ave., White Plains, N. Y. Four-page bulletin includes the company's expanded line of aluminum bronze wire. (370)

PHOTOCONDUCTIVE CELLS National Semiconductors Ltd., 230 Authier St., Montreal 9, Canada, offers a four-page bulletin describing NSL-45, -46 and -47 cadmium sulphide photoconductive cells in hermetically sealed enclosures. (371)

NEW! HIGH SENSITIVITY

GENERAL PURPOSE 247A

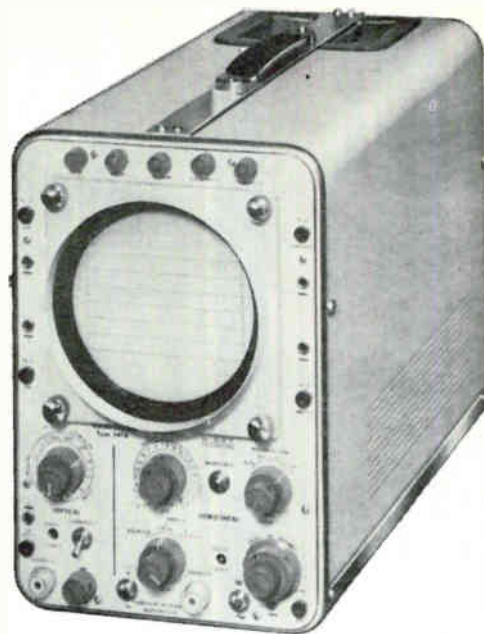

The type 247-A oscilloscope fully qualifies as a universal instrument because its performances and the size (13 cm (5") dia.) of its C.R. Tube authorize accurate measurements and tests in all fields of low-frequency instrumentation. Also, because of its simplicity of operation, the 247-A is ideally suited for practical laboratory work of an educational nature.

TECHNICAL SPECIFICATIONS

Vertical amplifier

1 channel; Frequency range: DC to 1 Mc/s (-3 dB)
Sensitivity: 50 mV/cm

AC: 10 c/s sine wave or 50 c/s square-wave to 100 Kc/s (-3 dB)
Sensitivity: 5 mV/cm

Calibrated attenuator: step-adjustable from 5 mV to 20 V/cm in 12 positions

Sequence: 1 - 2 - 5 - 10 etc...

Attenuator vernier ratio 1/3
Constant input impedance: 1 M Ω 47 pF

Sweep

Free-running - triggered - single sweep
Duration: 1 s/cm to 0.5 μ s/cm in 20 calibrated positions

Vernier: 1:3 ratio
x 5 magnification expanding sweep durations from 3 s/cm to 0.1 μ s/cm

Sync

5 positions: single-sweep, HF, LF, TV-line, TV-frame
Polarity: + or - internal or external

selection of triggering level

Horizontal Amplifier

Frequency range: 0 to 500 Kc/s (-3 dB)

Sensitivity: 1 V/cm or 10 V/cm (switch-selected)

Vernier: 0 to 1

Constant input impedance: 1 M Ω and 47 pF

Cathode-ray Tube

5 ADP 2 or equivalent type

Screen: 13 cm (5") dia.

deflection factors:

X: 30 V/cm (approx.)

Y: 20 V/cm (approx.)

Direct drive of H and V plates

Acceleration voltage: 3 Kv

MECHANICAL FEATURES

Light-alloy chassis, readily-detachable panel for easy access to circuits.

1) Tube complement

9/ECF80 - 2 NM2L or equivalent types

2) Power supply

105 - 115 - 127 - 220 - 240 V - 50 or 60 c/s

3) Dimensions

Width: 20.5 cm - (8")

Depth: 38.5 cm - (15")

Height: 31 cm - (12")

Weight: 14 kg - (30 lbs)

OTHER INSTRUMENTS

Oscilloscopes

204 A - High speed and fast rise oscilloscope

241 A - 242 A - 243 A, Multi-function osc. with plug-in preamplifiers.

255 B - Portable oscilloscope

245 A - High performance portable oscilloscope

246 A - High sensitivity low-frequency oscilloscope

248 A - Maintenance oscilloscope.

Sweep frequency Generators

411 A - Laboratory sweep frequency generator

410 B - TV - FM sweep frequency generator

476 A - Radio sweep frequency generator

Signal Generators

405 A - Low frequency RC signal gen. (30 c/s-300 Kc/s)

428 A - HF constant amplitude signal generator

(100 Kc/s-30Mc/s)

458 - Pulse generator (5 c/s - 50 Kc/s).

TV pattern generators

465 C - Portable electronic pattern generator

464 A - Test - pattern generator

Regulated power supplies

117 A - Transistorised regulated power supply

114 A - Regulated power supply

Cameras

1000 A - oscilloscope camera with Polaroid

1001 B - oscilloscope recorder

RIBET-DESJARDINS

MEASURE & CONTROL DEPARTMENT, 13-17, rue Périer MONTROUGE/PARIS TEL : ALESIA 24-40
CANADIAN BRANCH : RIBET-DESJARDINS (CANADA) Room 114, 5757 Decelles Avenue - MONTREAL.



IEE Names Israel Engineering Manager

EDMUND ISRAEL has been named manager of engineering by Industrial Electronic Engineers, Inc., North Hollywood-based manufacturer of rear-projection digital read-outs. He will be primarily responsible for new product design. He will also head up IEE research and development activities in electro-optics and related fields.

Prior to joining IEE, Israel served as staff engineer for reliability and quality assurance at STL on the OGO project.



Cutler-Hammer Elects President

PHILIP RYAN, president of Cutler-Hammer, Inc., Milwaukee, Wisc., for the past eight years, has announced his retirement effective December 31 and the election of Edmund B. Fitzgerald (picture), administrative vice president, to succeed him as president and chief executive officer of the electrical and electronic products manufacturing firm.

The new president joined Cutler-Hammer in 1946. He worked in development engineering, purchasing, sales and engineering before, in 1959, becoming vice president of engineering, a position he held until named administrative vice president in 1961. He was elected to the Cutler-Hammer board of directors in 1962.

Cutler-Hammer, Inc. has burgeoned in the post-war period from a relatively small company specializing in electrical controls to a diverse and growing industrial complex which spans electrical fields from power distribution and control equipment, to numerically controlled automation systems for industry, to electronic equipment for aerospace systems and vehicles.

The firm has plants in 10 cities, 72 strategically located sales offices, and 17 warehouses. Employment at the present time tops 8,000, of which more than 1,000 employees are degree-holding engineers or scientists.

GPL Elevates McGowan To Vice President

JAMES M. MCGOWAN has been named vice president, program management for General Precision, Inc.'s Link division. This is a new position in the company.

McGowan will also continue in the post of director of engineering. He will be responsible for all company-wide programs involving major systems efforts and has management responsibility for Link engineering activity both in Binghamton, N. Y. and Palo Alto, Calif.

General Microwave Appoints Hopfer



APPOINTMENT of Samuel Hopfer to the new post of vice president and director of engineering at General Microwave Corp., Farmingdale, N. Y., is announced. This represents the first addition to the company's active management at the corporate level since its founding over three years ago.

Prior to joining General Microwave, Hopfer was at PRD Electronics for 17 years.

Sigma Instruments Acquires OED

SIGMA INSTRUMENTS, INC., Braintree, Mass., has acquired Opto-Electronic Devices, Inc., Mountain View, Calif., it was announced by John J. Moran, executive vice president and general manager of Sigma Instruments.

The acquisition, which adds both

advanced solid-state switching technology and a range of new products utilizing this technology, enables Sigma to further expand its participation in the industrial, commercial, and military electronics markets.

Opto-Electronic Devices, Inc. will be operated as a subsidiary under the direction of Frank Litz.



Veeder-Root Names Vice President

WILLIAM WEBER, JR. has been appointed vice president of manufacturing of Veeder-Root Inc., Hartford, Conn., manufacturer of counting, controlling, and recording instruments.

Weber previously had been director of manufacturing for the Chicago plants of Consolidated Electronic Industries.



Andersen Laboratories Elects Hannon

ROBERT J. HANNON has been elected vice president of engineering at Andersen Laboratories, Inc., West Hartford, Conn. He was formerly deputy program manager for the Zmar (Zeus Multifunction Array Radar) program at Sylvania Electric Products, Waltham Laboratories, Waltham, Mass.

His new post was formerly held

NOW from DEI

**High Performance...Very Low Noise...
Modular**

VHF/UHF Satellite Telemetry Receiver

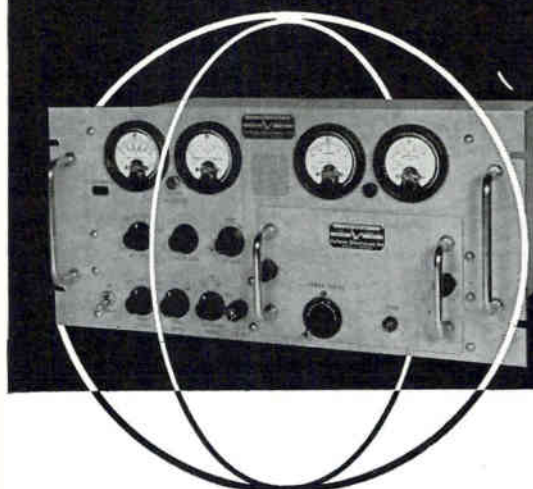

- Crystal controlled RF heads from 50 MC to 1000 MC
- IF bandwidths from 10 KC to 500 KC
- FM, AM, Phase-lock and Phase demodulators
- Plug-in pre-detection recording converters

Already used in more than a dozen unmanned earth orbit satellite programs, the Model TMR-6 telemetry receiver from Defense Electronics, Inc. has no true equivalent in its field.

The completely-modular unit has been specially-designed by DEI to accept inexpensive plug-in sub-assemblies . . . seven RF tuning heads . . . nine IF amplifiers and four demodulators . . . to cover all presently-assigned frequencies in the VHF/UHF spectrum.

The TMR-6 features crystal control of both oscillators, extremely low noise figures and can be adapted for use in PM systems by means of a phase-locked loop around the entire receiver. It is capable of tracking any frequency change introduced by Doppler shift, transmission and reception instabilities up to 0.007 per cent of the received frequency.

This versatile, low-cost receiver also accepts plug-in modules for pre-detection recording of either AM or FM with existing stationary head video tape recorders.

For real time data recovery at its finest, write for DEI bulletin TMR-6 . . . or call:



DEI *Defense Electronics, Inc.*

SERVING
GOVERNMENT
AND INDUSTRY

Rockville, Maryland

TWX: 301-949-6788 Phone: 301-946-2600

Sherman Oaks, California, Phone: 873-4322

COMINCO

HIGH PURITY METALS
AVAILABLE FORMS

clip and save

Product	ALUMINUM	ANTIMONY	ARSENIC	BISMUTH	CADMIUM	GOLD	INDIUM	LEAD	SILVER	TIN	ZINC
BARS	✓	✓	✓	✓	✓	✓	✓	✓	✓	✓	✓
SHEETS	✓				✓	✓	✓	✓	✓	✓	✓
WIRE	✓				✓		✓	✓		✓	✓
POWDER		✓	✓	✓	✓	✓	✓	✓	✓	✓	✓
SHOT		✓		✓	✓	✓	✓	✓	✓	✓	✓
ROD	✓			✓	✓		✓	✓	✓	✓	✓
RIBBON							✓	✓			
PRE-FORMS	✓				✓	✓	✓	✓	✓	✓	✓
SALTS					✓		✓				

COMINCO PRODUCTS, INC.

electronic materials division

933 West Third Avenue, Spokane 4, Washington
Phone Area Code 509 RI 7-7103 • TWX 509 328-1207

CIRCLE 58 ON READER SERVICE CARD

3402

TO ORDER REPRINTS

Fill in, cut out coupon below

insert in envelope and mail to:

electronics Reprint Dept.

330 W. 42nd Street, New York, N. Y. 10036

REPRINT ORDER FORM

For Listings of Reprints Available Turn To Reader Service Card

(To help expedite mailing of your reprints please send cash, check or money order with your order.)

For Reprints of the latest Special Report:

Materials for Space Age Electronics

Send me.....Reprints of Key No. R-42 at 50¢ each.

For Reprints of previous Special Reports or Feature Articles fill in below:

Send me.....Reprints of Key No.(s).....@.....¢ each.

(For prices, see Reader Service Card.)

*For orders of Bulk Reprints of other editorial articles in this issue or past issues:

Send me.....Reprints of page No.(s).....of issue date.....

of article entitled.....

*Minimum bulk order 100 copies. You will be advised of costs by return mail.

Name

Number of Street.....

City, Zone No., State.....

by Walther M. A. Andersen who became vice chairman of the board of directors in July.



Kessler Named Vice President

BERNARD KESSLER, formerly director of marketing, has been appointed vice president in charge of marketing at Mica Corporation, Culver City, Calif.

Kessler joined the glass/epoxy manufacturer seven years ago as manager, sales administration.



Varo Appoints Steed Division Head

VARO, INC., Garland, Texas, has appointed J. B. Steed general manager of its Electrokinetics division in Santa Barbara, Calif. This division manufactures electronic and electromechanical equipment.

Steed most recently served as marketing manager of the Varo Electronics Products division.

ITT Promotes N. H. Young

NORMAN H. YOUNG, JR. has been promoted to director of standards and application engineering at ITT

HOW TO USE YOUR ELECTRONICS BUYERS' GUIDE

Advertising Product Sections

Advertisements in the ELECTRONICS BUYERS' GUIDE are grouped together according to the kind of product advertised. All Power Supply advertisements, for example, will be found in the same section of the book. Thus it is made convenient for you to "shop" through the specifications presented to you by advertisers, without having to flip pages back and forth constantly. Keep your ELECTRONICS BUYERS' GUIDE close to your work area at all times.



Communication Systems, Inc., Paramus, N.J.

Young, a former director of command system design, has held key engineering and administrative positions with International Telephone and Telegraph System since 1942.

PEOPLE IN BRIEF

Ralph O. McIntosh, formerly with Westinghouse, named technical consultant to the applied physics lab of Bendix Research Laboratories div. John R. Mains, previously sales mgr., appointed mgr. of the New Products div. of Phillips Control Co. Louis A. Reiners promoted to materials mgr. for Raytheon's Marine Products Operation. James B. Hart moves up to chief engineer of Dynascan Corp. Charles R. Gray and Carl I. Swanson leave Philco Corp. to join International Resistance Co. as mgr., microcircuit application development, and mgr. microcircuit customer services, respectively. Edward N. Willie from Lionel Electronic Laboratories to Micronia Amplifier Corp. as chief engineer. George F. Daly advances to director of patent engineering in IBM's General Products div. William J. McFarland raised to operations mgr. of the Industrial Controls div. of Emerson Electric Mfg. Co. Martin L. Killgallon, formerly with Phelps Dodge, appointed works mgr. at Riverside-Alloy Metal div., H. K. Porter Co. Ron Salestrom and Richard Wells leave Dale Electronics, Inc., to become vice presidents of Mid-Continent Laboratory, Inc. Edward E. Kirkham, previously with Pratt & Whitney, Inc., named mgr. of engineering-product design for Veeder-Root Inc. William F. Juptner, v-p and g-m of the Relays div. of Babcock Electronics Corp., elected a director of the company. Horst Oeckinghaus, until recently with International Electronics Industries, joins C. P. Clare & Co. as a senior project engineer. Three promotions announced at Memorex Corp.: Edward S. Seaman to v-p, sales; Eric D. Daniel to director of research; Rex D. Lindsay to director of mfg.

EMPLOYMENT OPPORTUNITIES

The advertisements in this section include all employment opportunities — executive, management, technical, selling, office, skilled, manual, etc. Look in the forward section of the magazine for additional Employment Opportunities advertising.



E. E.'s
for FEE-PAID Positions
WRITE US FIRST!
Use our confidential application for professional, individualized service . . . a complete national technical employment agency.
ATOMIC PERSONNEL, INC.
Suite 1207L, 1518 Walnut St., Phila. 2, Pa.

SEARCHLIGHT SECTION

(Classified Advertising)

BUSINESS OPPORTUNITIES

EQUIPMENT - USED or RESALE

DISPLAYED RATE

The advertising rate is \$27.25 per inch for all advertising appearing on other than a contract basis. Contract rates quoted on request. AN ADVERTISING INCH is measured 1/8 inch vertically on one column, 3 columns—30 inches—to a page. EQUIPMENT WANTED or FOR SALE ADVERTISEMENTS acceptable only in Displayed Style.

UNDISPLAYED RATE

\$2.70 a line, minimum 3 lines. To figure advance payment count 5 average words as a line.

PROPOSALS, \$2.70 a line an insertion.

BOX NUMBERS count as one line additional in undisplayed ads.

DISCOUNT OF 10% if full payment is made in advance for four consecutive insertions of undisplayed ads (not including proposals).

INVENTORY SALE!

RECENTLY SUPERSEDED MODELS—BRAND NEW, FULLY WARRANTED, FROM CURRENT STOCK! FAMOUS FERRIS INSTRUMENTS OF THE FOLLOWING TYPES: AM SIGNAL GENERATORS: MODELS 16, 22, 24; MICROVOLTERS: MODELS 18, 20; FM SIGNAL GENERATORS: MODEL 35; CRYSTAL CALIBRATORS: MODELS 33, 34; RADIO NOISE AND FIELD STRENGTH METERS: MODEL 32; AT A FRACTION OF ORIGINAL PRICES!

Standard Factory Service and Spare Parts Guaranteed Available for Next 10 Years.

WRITE, WIRE, PHONE FOR PRICES!

(Ask for the NEW Ferris catalog, too!)

FERRIS INSTRUMENT CO., INC.

Boonton, N. J. (201) DE 4-0780

CIRCLE 950 ON READER SERVICE CARD

Antique

TELEPHONES
As is complete, decorative purpose \$17.50. Working order, inter-comm. \$19.50 Ext. on dial \$24.50, talking circuit only. Write for complete list. All shipments FOB, Simpson, Pa.
TELEPHONE ENGINEERING CO.
Dept. 112963, Simpson, Pa.



CIRCLE 951 ON READER SERVICE CARD

THIS WEEK 2K25 Klystron Mount. PRD type w/ var att. & full-shielding. \$45.00 ea.

RADAR AUTO-TRACK & TELEMETRY ANTENNA PEDESTALS 3 & 10 CM. SCR 5M AUTOTRACK RADARS. M-33 RADAR TPS-10 SEARCH. APS-45 TPS-100 MT. FINDERS. WX RADARS. FPN-320CA. APS-10 APS-15B APS-27 (AMTI) SEARCH. APN-102 DOPPLER DOZENS MORE CARBONITRONS PHNS. 25-1123-6 MEGAWATT PULSE MODULATORS. CAVITIES. PULSE TRANSFORMERS. IF STRIPS. WAVEGUIDE. BENDS 200 MC. 1 KMC. 3 KMC. 6 KMC. 9 KMC. 24 KMC. RF PKGS.
RADIO RESEARCH INSTRUMENT CO.
550 5TH AVE., NEW YORK 36, N.Y. JU 6-4691

CIRCLE 952 ON READER SERVICE CARD

INDEX TO ADVERTISERS

Aeroflex Laboratories Inc.	43	Japan Piezo Electric Co., Ltd.	40	CLASSIFIED ADVERTISING	
Allen-Bradley Co.	3			F. J. Eberle, Business Mgr. (2557)	
AnSCO				EMPLOYMENT OPPORTUNITIES . . .	59
Div. of General Aniline &		Kay Electric Co.	22	EQUIPMENT	
Film Corp.	8	• Kepco, Inc.	45	(Used or Surplus New)	
Arnold Engineering Co., The.	47	Krohn-Hite Corporation	12	For Sale	59
Carborundum Company, The.	21	Marquardt Corp., The.	13		
• Carter-Princeton	49	Melpar Inc.	54		
• Clifton Precision Products Co.,		Memorex Corp.	4		
Inc.	16	• Minnesota Mining & Mfg. Co.			
• Cominco Products, Inc.	58	Mincom Division	37		
Corning Electronics					
Div. of Corning Glass Works	9				
		Radio Corporation of America			
Defense Electronics, Inc.	57	4th cover			
Delco Radio	38, 39	• Ribet-Desjardins	55		
Englehard Industries, Inc.	51	Sperry Electronic Tube			
		Div. Sperry Rand Corp.	3rd cover		
• Globe Industries, Inc.	7	Sprague Electric Co.	6		
Gudebrod Bros. Silk Co., Inc.	41	Suffolk County Dept. of			
		Commerce & Industry.	42		
		• Texas Instruments Incorporated			
Heinemann Electric Co.	15	Metals & Controls Division	53		
• Hewlett-Packard Company. 2nd cover		Ward Leonard Electric Co.	46		

• See advertisement in the July 25, 1963 issue of electronics Buyers' Guide for complete line of products or services.

This Index and our Reader Service Numbers are published as a service. Every precaution is taken to make them accurate, but electronics assumes no responsibilities for errors or omissions.

electronics



Audit Bureau
of Circulation



Associated Business
Publications

AUDITED PAID CIRCULATION

JAMES T. HAUPTLI (2210)
Advertising Sales Manager

HENRY M. SHAW (3485)
Market Research Manager

DAVID M. TEMPEST (3139)
Promotion Manager

electronics Buyers' Guide

R. S. QUINT (2335)
General Manager

RICHARD J. TOMLINSON (3191)
Business Manager

THEODORE R. GEIPEL (2044)
Production Manager

NEW YORK TELEPHONE: Dial Direct:
971 plus number in parenthesis,
Area Code 212

ADVERTISING REPRESENTATIVES

ATLANTA, GA. 30309
Michael H. Miller, Robert C. Johnson
1375 Peachtree St. N.E.,
Trinity 5-0523 (area code 404)

BOSTON, MASS. 02116
William S. Hodgkinson
McGraw-Hill Building, Copley Square,
Congress 2-1160 (area code 617)

CHICAGO, ILL. 60611
Harvey W. Wernecke,
Robert M. Denmead
645 North Michigan Avenue,
Mohawk 4-5800 (area code 312)

CLEVELAND, OHIO 44113
Paul T. Fegley
55 Public Square, Superior 1-7000
(area code 216)

DALLAS, TEXAS 75201
Frank Le Beau
The Vaughn Bldg.,
1712 Commerce St.
Riverside 7-9721 (area code 214)

DENVER, COLO. 80202
John W. Patten
Tower Bldg., 1700 Broadway,
Alpine 5-2981 (area code 303)

HOUSTON, TEXAS 77025
Kenneth George
Prudential Bldg., Halcombe Blvd.,
Riverside 8-1280 (area code 713)

LOS ANGELES, CALIF. 90017
Ashley P. Hartman, John G. Zisch,
1125 W. 6th St., Huntley 2-5450
(area code 213)

NEW YORK, N. Y. 10036
Donald H. Miller (212) 971 3615
George F. Werner (212) 971 3617
Donald R. Furth (212) 971 3616
500 Fifth Avenue

PHILADELPHIA, PA. 19103
Warren H. Gardner, William J. Boyle
6 Penn Center Plaza,
LOcust 8-4330 (area code 215)

SAN FRANCISCO, CALIF. 94111
Richard C. Alcorn
255 California Street,
Douglas 2-4600 (area code 415)

LONDON W1:
Edwin S. Murphy Jr.
34 Dover St.

FRANKFURT/Main:
Matthee Herfurth
85 Westendstrasse

GENEVA:
Michael R. Zeynel
2 Place du Port

TOKYO:
George Olcott,
1, Kotohiracho, Shiba, Minato-ku

electronics

READER SERVICE

Use these handy prepaid **POST CARDS** for more detailed information on: **PRODUCTS ADVERTISED, NEW PRODUCTS, LITERATURE** of the **WEEK**

Circle the number on the **READER SERVICE** post card that corresponds to the number at the bottom of the Advertisement, New Product item, or the Literature of the Week selection in which you are interested.

Please print clearly. All written information must be legible to be efficiently processed.

ALL FOREIGN INQUIRIES

that cannot reach **electronics** before the expiration dates noted on the Reader Service post card, must be mailed directly to the manufacturer. The manufacturer assumes all responsibilities for responding to inquiries. **electronics** merely provides and clears requests for information from inquirer to manufacturer.

Correct amount of postage must be affixed for all foreign mailings.

TO SUBSCRIBE TO OR TO RENEW **electronics** —

Fill in the "For Subscriptions" area on the card if you desire to subscribe to or renew your present subscription to **electronics**. Send no money. **electronics** will bill you at the address indicated on the Reader Service post card.

MULTI-PRODUCT ADVERTISEMENTS —

For information on specific items in multi-product advertisements which do not have a specific Reader Service number indicated write directly to manufacturer for information on precise product in which you are interested.

Name _____ Title _____

Company _____

Address _____

1	18	35	52	69	86	103	120	137	154	171	188	205	222	239	256	273	290	307	324	341	358	375	392
2	19	36	53	70	87	104	121	138	155	172	189	206	223	240	257	274	291	308	325	342	359	376	393
3	20	37	54	71	88	105	122	139	156	173	190	207	224	241	258	275	292	309	326	343	360	377	394
4	21	38	55	72	89	106	123	140	157	174	191	208	225	242	259	276	293	310	327	344	361	378	395
5	22	39	56	73	90	107	124	141	158	175	192	209	226	243	260	277	294	311	328	345	362	379	396
6	23	40	57	74	91	108	125	142	159	176	193	210	227	244	261	278	295	312	329	346	363	380	397
7	24	41	58	75	92	109	126	143	160	177	194	211	228	245	262	279	296	313	330	347	364	381	398
8	25	42	59	76	93	110	127	144	161	178	195	212	229	246	263	280	297	314	331	348	365	382	399
9	26	43	60	77	94	111	128	145	162	179	196	213	230	247	264	281	298	315	332	349	366	383	400
10	27	44	61	78	95	112	129	146	163	180	197	214	231	248	265	282	299	316	333	350	367	384	401
11	28	45	62	79	96	113	130	147	164	181	198	215	232	249	266	283	300	317	334	351	368	385	402
12	29	46	63	80	97	114	131	148	165	182	199	216	233	250	267	284	301	318	335	352	369	386	403
13	30	47	64	81	98	115	132	149	166	183	200	217	234	251	268	285	302	319	336	353	370	387	404
14	31	48	65	82	99	116	133	150	167	184	201	218	235	252	269	286	303	320	337	354	371	388	405
15	32	49	66	83	100	117	134	151	168	185	202	219	236	253	270	287	304	321	338	355	372	389	900
16	33	50	67	84	101	118	135	152	169	186	203	220	237	254	271	288	305	322	339	356	373	390	901
17	34	51	68	85	102	119	136	153	170	187	204	221	238	255	272	289	306	323	340	357	374	391	902

Searchlight Section	950	952	954	956	958	960	962	964	966	968	970
	951	953	955	957	959	961	963	965	967	969	

Nov. 29, 1963
Card Expires
Jan. 29, 1964

FOR SUBSCRIPTIONS

New Renewal } Check One Box

Check One Box Below

DOMESTIC AND CANADA

3 years—\$12.00
 1 year—\$6.00

FOREIGN

1 year—\$20.00

Product(s) M'd'd

Services

FIRST CLASS
PERMIT NO. 24327
PHILADELPHIA, PA.

BUSINESS REPLY MAIL
NO POSTAGE STAMP NECESSARY IF MAILED IN THE UNITED STATES

Postage Will Be Paid By

electronics
Reader Service Dept.
Box 8635
Philadelphia, Pa. 19101



REPRINT SERVICE

All **electronics** Editorial Matter

Is Available in Reprint Form:

(A) Reprints of Special Reports and Feature Articles with prices for varying quantities. See list on right hand side of this page. Send your order to **electronics** Reprint Department at address indicated below. To expedite mailing of your order for single reprints please send cash, check or money order with your order.

(B) Bulk reprints of editorial matter in current or past issues. The minimum quantity for bulk reprints is 100 copies. The higher the quantity ordered, the more economical the cost per copy. Prices quoted on request.

Bulk reprints can be made up with the cover of the magazine on the front page, and your advertising message on the back page. To order reprints or for further information, please write to: **electronics** Reprint Department, 330 West 42nd Street, New York, N.Y. 10036 Telephone: Area Code 212 971-3140.

(You may order Reprints by Key No. Using the Reprint Order Form on Page 58)

FIRST CLASS
PERMIT NO. 24327
PHILADELPHIA, PA.

BUSINESS REPLY MAIL
NO POSTAGE STAMP NECESSARY IF MAILED IN THE UNITED STATES

Postage Will Be Paid By

electronics
Reader Service Dept.
Box 8635
Philadelphia, Pa. 19101



Name _____ Title _____

Company _____

Address _____

1	18	35	52	69	86	103	120	137	154	171	188	205	222	239	256	273	290	307	324	341	358	375	392	
2	19	36	53	70	87	104	121	138	155	172	189	206	223	240	257	274	291	308	325	342	359	376	393	
3	20	37	54	71	88	105	122	139	156	173	190	207	224	241	258	275	292	309	326	343	360	377	394	
4	21	38	55	72	89	106	123	140	157	174	191	208	225	242	259	276	293	310	327	344	361	378	395	
5	22	39	56	73	90	107	124	141	158	175	192	209	226	243	260	277	294	311	328	345	362	379	396	
6	23	40	57	74	91	108	125	142	159	176	193	210	227	244	261	278	295	312	329	346	363	380	397	
7	24	41	58	75	92	109	126	143	160	177	194	211	228	245	262	279	296	313	330	347	364	381	398	
8	25	42	59	76	93	110	127	144	161	178	195	212	229	246	263	280	297	314	331	348	365	382	399	
9	26	43	60	77	94	111	128	145	162	179	196	213	230	247	264	281	298	315	332	349	366	383	400	
0	27	44	61	78	95	112	129	146	163	180	197	214	231	248	265	282	299	316	333	350	367	384	401	
1	28	45	62	79	96	113	130	147	164	181	198	215	232	249	266	283	300	317	334	351	368	385	402	
2	29	46	63	80	97	114	131	148	165	182	199	216	233	250	267	284	301	318	335	352	369	386	403	
3	30	47	64	81	98	115	132	149	166	183	200	217	234	251	268	285	302	319	336	353	370	387	404	
4	31	48	65	82	99	116	133	150	167	184	201	218	235	252	269	286	303	320	337	354	371	388	405	
5	32	49	66	83	100	117	134	151	168	185	202	219	236	253	270	287	304	321	338	355	372	389	406	
6	33	50	67	84	101	118	135	152	169	186	203	220	237	254	271	288	305	322	339	356	373	390	407	
7	34	51	68	85	102	119	136	153	170	187	204	221	238	255	272	289	306	323	340	357	374	391	408	
Searchlight Section					950	952	954	956	958	960	962	964	966	968	970									
					951	953	955	957	959	961	963	965	967	969										

Reprints Available on
Past Special Reports
and Feature Articles

- Key No. **R-19** Medical Electronics — 7 Part Series
42 pages \$1.50
- Key No. **R-26** Lasers Devices and Systems — 4 Part Series
23 pages \$1.00
- Key No. **R-29** Bionics — 4 Part Series
19 pages \$1.00
- Key No. **R-30** Graphical Symbols for Electronics Diagrams
4 pages \$1.00
- Key No. **R-31** 1962 Electromagnetic Spectrum Chart
8 pages \$1.00
- Key No. **R-36** Electronics Markets 1963: What The Future Holds
30 pages *
- Key No. **R-37** Advances in Microminiaturization
16 pages 50c
- Key No. **R-38** Family Tree of Semiconductors
6 pages 50c
- Key No. **R-39** Radio Frequency Interference 24 pages *
- Key No. **R-40** Tunnel Diodes 4 Part Series Summarizing five years with a new component.
26 pages \$1.00
- Key No. **R-41** Telemetry Today A summary of techniques trends and future plans for a growing aerospace industry.
7 pages 25c
- Key No. **R-42** Materials for Space Age Electronics. A comprehensive survey of a materials technology that is now shaping the course of the entire electronics industry. A must for every engineer.
16 pages 50c
- Key No. **R-44** **ELECTRONICS COLOR CODES CHART** 4 pages 50c

Nov. 29, 1963
Card Expires
Jan. 29, 1964

FOR SUBSCRIPTIONS

New Renewal } Check One Box

Check One Box Below

DOMESTIC AND CANADA

3 years—\$12.00
 1 year—\$6.00

FOREIGN
 1 year—\$20.00

Product(s) M't'd _____

Services _____

*Price on these items are 1-10 copies 75c each. 11-24 copies 60c each, 25 or more copies 50c each unless otherwise noted.

SPECIAL

Key No. **R-43** The Impact of Microelectronics. The proceedings of the June 26-27 conference on the Impact of Microelectronics, co-sponsored by electronics and the Armour Research Foundation (now IIT Research Institute). This book contains important technical and marketing information contributed by industry leaders.
120 pages \$3.50 per copy

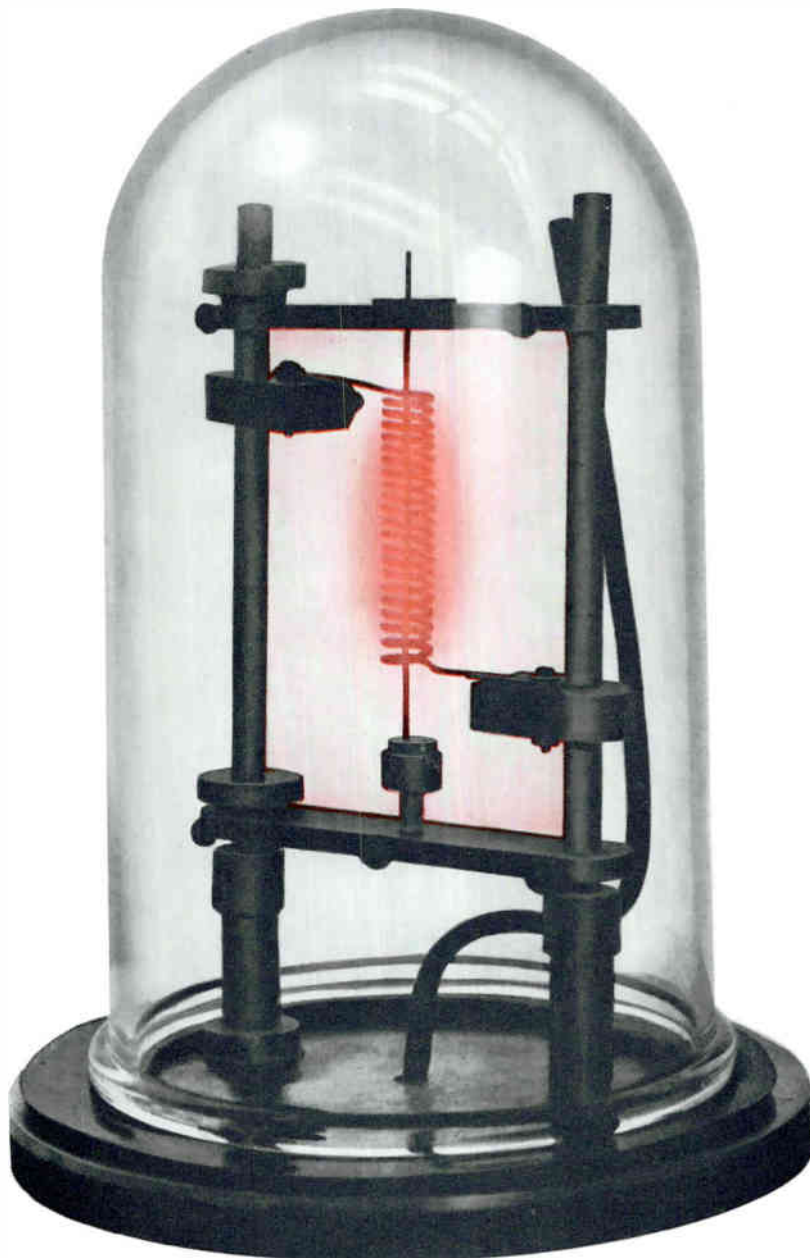

To optimize a TWT . . . use a crystal ball



STC-278, 50 watt pulsed C band TWT, provides superior electrical performance as a driver in radar transmitters, rf amplifiers, and other wide band applications.

"Pyrolytic deposition" is the fancy name for it. In simpler terms, it's Sperry's method of using heat and a controlled atmosphere to put attenuation on TWT support rods in a very precise manner. Result: higher gain and improved efficiency for Sperry traveling wave tubes.

This is only part of the Sperry effort to optimize the electrical parameters of TWT's. Attenuators are important . . . beam focusing, amplitude fine structure, and gun design get their share of attention too. All these programs are devoted to a single objective . . . the production of TWT's with a near-perfect mix of electrical characteristics.

Many of these efforts are already bearing fruit in the form of operational hardware. Production tubes like the STL-405 and STS-101 (200 W performance over octave bandwidth at L and S bands) and the STC-278 (exceptional fine structure and phase linearity characteristics) vouch for Sperry's success.

A NEW TECHNICAL PAPER gives full engineering and scientific details of the considerations involved in electrically optimizing traveling wave tubes. For your copy, write Sperry, Gainesville, Florida, or contact your Cain & Co. representative. In Europe, contact Sperry Europe Continental, Paris.

SPERRY
ELECTRONIC
TUBE
DIVISION
SPERRY RAND CORPORATION
GAINESVILLE FLORIDA

CIRCLE 901 ON READER SERVICE C.

NOW YOU CAN ELIMINATE TEMPERATURE CONTROLS FROM FERRITE MEMORIES

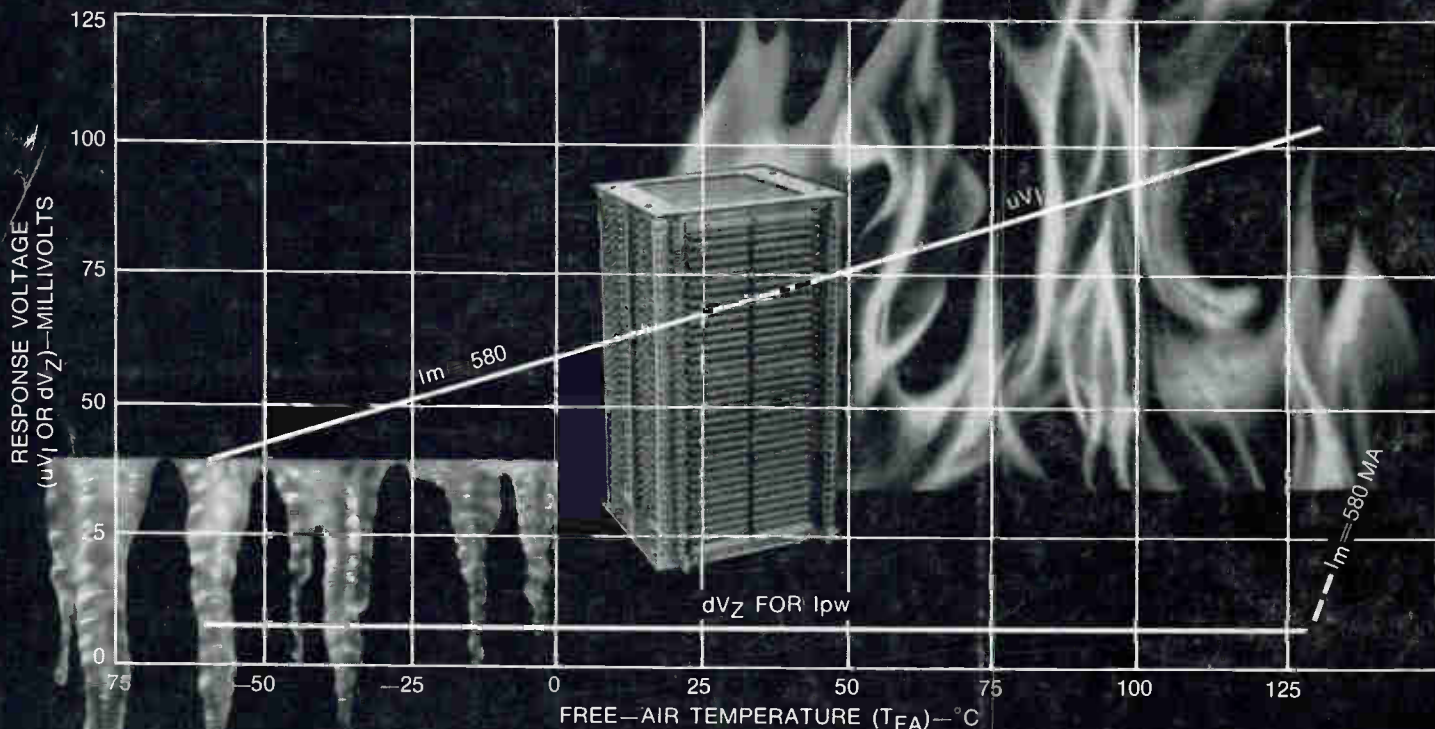

At -55°C... or +125°C

New RCA Wide-Temperature-Range Memory Stacks Require Only 290 Ma Half-Drive Current

RCA low-drive wide-temperature-range ferrite memory planes and stacks operate without temperature controls or current compensation over any 100°C or greater temperature interval between the limits of -55°C and +125°C.

Memory planes and stacks using RCA 264M1 ferrite cores provide high-speed operation over the full temperature range with less than 300 ma half-drive current. At full driving current of 580 ma, these temperature-stable cores have a switching time of approximately 1.2 μ sec, making them suitable for use in magnetic-memory systems with operating cycles in the 5 μ sec region.

These performance characteristics are available in a variety of wide-temperature-range RCA

cores, planes, and stacks. Other RCA cores, planes, and stacks are available in a wide variety of configurations for coincident current, word address, and switching applications at speeds to 250 nsec; complete RCA memory systems range in size from 256 words x 8 bits to 16,384 words x 20 bits and offer speeds to 250 nsec.

Whatever the memory requirements, your RCA Representative is prepared to provide a completely coordinated application service for RCA Computer Transistors and Memory Products. Call him at your nearby RCA Field Office. For technical data, write: RCA Electronic Components and Devices, Memory Products Operation, Section F-N-11, 64 "A" Street, Needham Heights 94, Mass.

RCA FIELD OFFICES—EAST: 32 Green St., Newark 2, N. J., 485-3900 • 731 James St., Rm. 402, Syracuse 3, N. Y., GR 4-5591 • 605 Marlton Pike, Ertlan, N. J., HA 8-4802 • Greater Baltimore Area, 1725 "K" St., N.W., Washington 6, D. C., FE 7-8500 • NORTH-EAST: 64 "A" St., Needham Heights 94, Mass., HI 4-7200 • SOUTHEAST: 200 East Marks St., Orlando, Fla., 425-5563 • CENTRAL: Suite 1154, Merchandise Mart Plaza, Chicago 54, Ill., 527-2900 • 2132 East 52nd St., Indianapolis 5, Ind., CL 1-1405 • 5805 Excelsior Blvd., Minneapolis 15, Minn., WE 9-0676 • 714 New Center Bldg., Detroit 2, Mich., TR 5-5600 • WEST: 6801 E. Washington Blvd., Los Angeles 22, Calif., RA 3-8361 • 1838 El Camino Real, Burlingame, Calif., OX 7-1620 • 2250 First Avenue, S., Seattle 4, Wash., MA 2-8816 • GOVERNMENT: 224 N. Wilkinson St., Dayton 2, Ohio, BA 6-2366 • 1725 "K" St., N.W., Washington 6, D. C., FE 7-8500 • RCA INTERNATIONAL DIVISION, 30 Rockefeller Plaza, New York 20, New York, Cable Address: RADIOINTER, N. Y.



The Most Trusted Name in Electronics

CIRCLE 902 ON READER SERVICE CARD