

- Solving Chroma Problems
- More Adventures in TV Servicing



journal
January/February 1975

SAVE \$33.65...

Our loss is your gain . . . we overbought and these new, world-renowned Olivetti electric adding machines must be moved!

Original
List
~~\$78.50~~

OLIVETTI SUMMA 19

Save almost \$35 . . . **Now Only \$44.95**

Note. Although we overbought, the supply is limited. These will go out on a first-come, first-served basis.

Note: Please add \$3.00
for shipping and handling

Stock No. 19TO

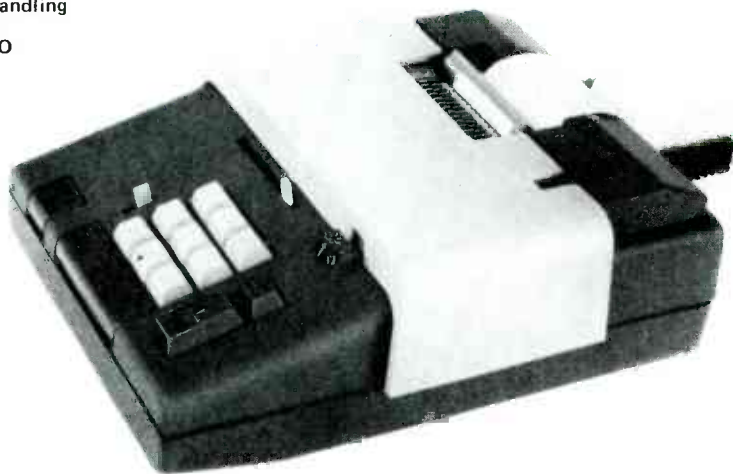

Order form
in back of
Journal

Plan household budgets, check statements, finish office work at home, itemize purchases, figure expenses easily and accurately. Breeze through tax reports, grocery bills, balance checkbooks, and solve your children's homework. The Olivetti Summa 19 is no larger than a sheet of regular typing paper, weighs under 8 pounds, yet offers all the important features, speed and touch-operation usually found only in higher-priced machines. Its low, slim silhouette permits unique portability from desk to desk, city to city, or office to home. A complete adding-figuring machine, the Summa 19 is at home with office work. It adds (of course), subtracts, multiplies and prints entries and answers on tape in large, clear figures for permanent reference.

FEATURES:

- Standard 10-key electric keyboard
- 7 digit listing
- 8 digit totaling capacity (999,999.99)
- Direct subtraction
- Calculates at 200 cycles per minute
- Clearing, non-add and repeat keys
- Column indicator
- Multiplication by repeat addition



journal

January/February 1975
Volume 33, No.1



<i>James Crudup</i>	2	SOLVING CHROMA PROBLEMS
<i>J. B. Straughn</i>	8	MORE ADVENTURES IN TV SERVICING
<i>Ted Beach</i>	19	HAM NEWS
	22	NRI HONORS PROGRAM AWARDS
<i>Tom Nolan</i>	24	ALUMNI NEWS

EDITOR AND PUBLISHER

William F. Dunn

TECHNICAL EDITOR

Ted Beach

MANAGING EDITOR

Tom Beadling

EDITORIAL ASSISTANT

Mildred Duncan

STAFF ARTISTS

Bill Massey

Arthur Susser

Ernie Blaine

In this issue, budding Journal author James Crudup explores some of the vexing problems associated with color television repair. And veteran writer J. B. Straughn adds yet another chapter to his ongoing series of practical television servicing case histories.

The NRI Journal is published bimonthly by the National Radio Institute, a division of the McGraw-Hill Continuing Education Center, 3939 Wisconsin Avenue, Washington, D.C. 20016. The subscription price is two dollars yearly or 35 cents per single copy. Second-class postage is paid at Washington, D.C.

Solving Chroma Problems

by James Crudup

In order to become really proficient in color servicing, as in any field, you must have basic knowledge. However, practice is equally as important as theory in obtaining the basic knowledge of color servicing.

Many newcomers jump into color TV servicing before they are really equipped to do so. If you are a student of the TV servicing course, you are probably prepared to service color sets if you've completed the majority of your lessons and training kit experiments. If you are a graduate, you are certainly ready to service color sets.

It is also important that you have the right equipment to service color receivers. A minimum of equipment is required. You will need a good wide-band oscilloscope, a TV pattern (color-bar) generator, and of course some type of voltmeter. The latter should be a solid-state, high-impedance voltmeter or the old standard, the vtvm. With these three pieces of equipment and a good basic understanding of electronic theory you should be able to solve any color problem that might occur.

Four common color problems are: loss of one color, loss of color sync, loss of color balance, and total loss of color.

As with any problem you should use a logical troubleshooting approach. Your first step should be to analyze the problem and make the necessary adjustments to determine which stage might be at fault. Don't overlook the possibility of customer misadjustment of the set. Quite often customers will make service adjustments to their sets (service adjustments are controls on the back of the set or inside the set). This generally causes the set to produce a poor color picture.

Since the causes of the four symptoms listed above are generally confined to the chroma circuits, we will assume that the defect is in the color section. I might also point out that symptoms such as no color or weak color can be caused by a weak received signal or a defect in the signal path prior to the color section. A defective antenna or transmission line can also affect the color information before it reaches the chroma circuits. In rare cases improper tuner or i-f alignment can attenuate the color portion of the received signal.

To get down to cases, let's first discuss a Toshiba TAC6350 chassis. This color portable had a beautiful black-and-white picture but no color. My first step was to check the operation of the receiver on an inactive channel to see if I could obtain "colored snow" on the screen. I adjusted the color killer control fully clockwise to disable the color killer. I then advanced the color control on the front of the receiver fully clockwise. Nothing but black and white snow.

In some cases the complete loss of color can be due to the color killer control being misadjusted. If this is the case, you should be able to obtain color confetti when you are tuned to an unused channel. Also, the loss of color on one channel can result from the color killer control being misadjusted. In some areas remote from a TV station, the color killer may have to be readjusted in order to receive color from all of the local channels.

At this point I was sure the problem with the Toshiba was due to a circuit defect so I pulled the back off of the receiver and warmed up my color-bar generator, oscilloscope and vtvm. I connected the color-bar generator to the set and set it up for a color-bar pattern. My first check with the oscilloscope was at the base of the first chroma amplifier, Q501 (Figure 1). The chroma signal looked good at the base so I then moved the scope to the collector. To my surprise I didn't see a signal at the collector of the stage.

To reaffirm that I had the right signal at the base, I cut the color-bar generator off and the signal disappeared. I turned the instrument back on and adjusted the color

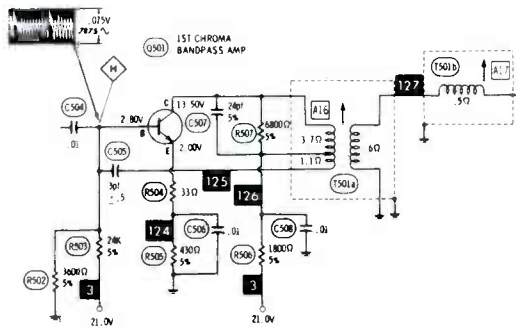

Courtesy Howard W. Sams

FIGURE 1. TOSHIBA BANDPASS AMPLIFIER.

level control on the generator and the pattern increased and decreased accordingly. I was convinced I had the right signal present.

Next, I measured the voltages on Q501. At the emitter I had approximately 0.1 volt. This, of course, was not right. The schematic indicated two volts. I then measured the base voltage—approximately 0 volts. Next I checked the collector. The voltage was approximately 20 volts, which indicated that the stage was probably cut off.

I then measured the 21-volt source at terminal 3 on the board. I had 21 volts present but nothing at the base of Q501. This indicated that I had an open circuit in the voltage divider network consisting of R502 and R503. Disconnecting power, I measured the resistance across R503. In the circuit it measured open. To confirm my diagnosis I removed the part and checked it. It checked open. Installing a new 24-kilohm resistor restored beautiful color to the set.

RCA CTC15

This set displayed the characteristic symptom of a loss of color sync. This symptom is sometimes referred to as the “barber pole” effect since the pattern does appear very similar to the old-fashioned barber pole that appeared outside most barber shops in days past.

When the 3.58-MHz oscillator is not locked in frequency and phase with the color burst, the colors in the picture break up into bands of color. A small frequency error produces a few broad bands of color while a large frequency error produces many small bands of color. Also, the color bands may hold still, move slowly, or move rapidly. The pattern holds still because the off-frequency oscillator is held

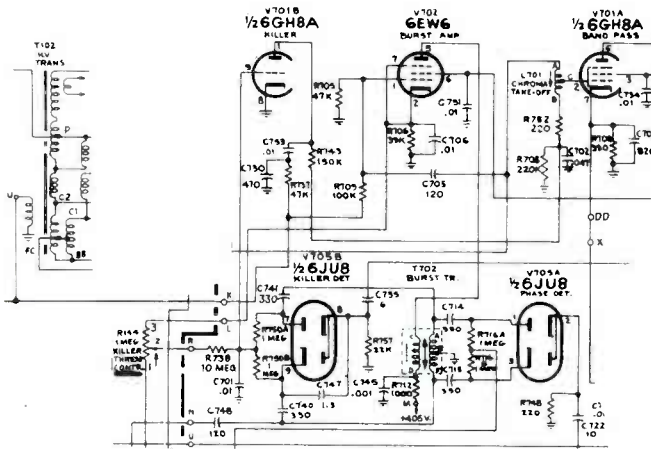

Courtesy RCA

FIGURE 2. RCA VICTOR CHASSIS CTC15.

there by the sync circuit. When the oscillator is free-running, the color bars may move up or down as the oscillator drifts. The stages that affect the color sync are the 3.58-MHz oscillator, the reactance control stage, the phase detector and the burst amplifier.

You will notice from Figure 2 that the burst amplifier stage is a 6EW6. The set had a beautiful black-and-white picture but the color would not sync. Approximately eight bars of color appeared in the black-and-white picture. Turning the color control up and down, of course, varied the color level. I substituted the burst amplifier, the phase detector, and the reactance control tubes with no luck. Back on the service bench I began taking voltage readings and allowed my oscilloscope to warm up. My first check was at the burst amplifier plate. I selected this stage because the burst amplifier corrects the phase of the reference oscillator in the color circuits. If the signal is not correct at the burst amplifier, the oscillator will not sync. I totally disregarded the possibility of misalignment since stages don't normally detune themselves. At the plate, pin 5 of V702, the signal was approximately 12 volts peak-to-peak. This was less than half that the schematic called for. I connected the probe to the grid of the burst amplifier to observe the horizontal keying pulse. The signal was much smaller in amplitude than the schematic indicated. I began tracing the line down to the flyback transformer. Following the line I came to point U on the flyback. One end of the winding was supposed to have been grounded. Checking from point U to ground turned up an open circuit. Further checking turned up a cold solder connection at terminal FC. Reheating the connection produced a low resistance across the winding which in turn allowed me to receive approximately 75 volts peak-to-peak at pin 1 of V702. Turning the set on produced a satisfactory color picture. The color locked in solidly.

ADMIRAL K10

The set displayed an excellent black-and-white picture with very little color. With the color control on the front of the receiver turned to maximum, you could barely see signs of color in the picture. Adjusting the color killer control, the fine tuning, and the agc made no difference.

This was a hybrid circuit and it was fairly easy to work on. The symptom, weak color, told me immediately that the problem had to be after the first bandpass amplifier stage, Q15 (Figure 3), since the color was locking into sync with no difficulty. Notice from the schematic that the burst signal is taken off the primary winding of the bandpass transformer at the output of the first bandpass amplifier.

Since I had the manufacturer's diagram, I had all of the waveforms readily available. This, of course, makes it very easy to troubleshoot most sets. It's a simple matter of tracing the waveforms and then checking the necessary voltages to pinpoint the problem. I connected my scope to the color control since it was a convenient point to look at the signal. It looked good at the color control and as I varied the control the signal changed in amplitude. I then checked the signal at the base. The signal looked good at the base of the second chroma bandpass amplifier, Q16. At the

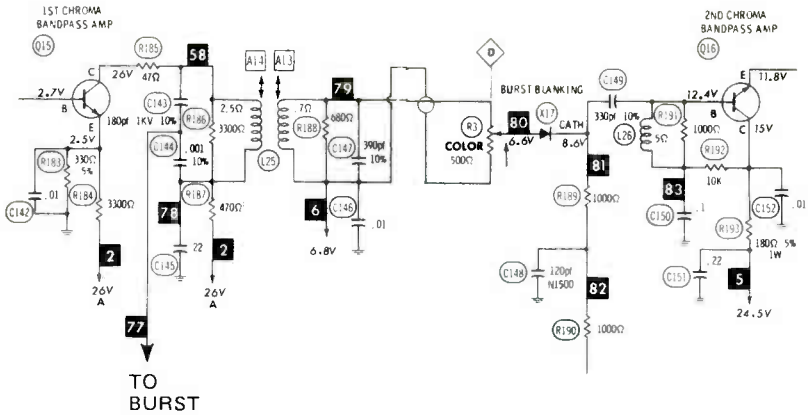

Courtesy Howard W. Sams

FIGURE 3. ADMIRAL CHASSIS K10-2A.

emitter, the signal was much smaller in amplitude than it was at the base. The signal at the emitter was less than half the amplitude of the signal at the base.

This aroused suspicion and I decided to take some voltage readings. The voltage looked good at the collector of the stage. But it was lower than indicated by the schematic at the base. A quick resistance check from the base of the stage to ground turned up the resistance reading of approximately 2 kilohms. I suspected an open coil, L26, but a resistance check across R191 which is in parallel with the coil turned up a very low reading. It measured approximately 5 ohms. I then measured the resistance from the junction of R192 and R191. I had approximately 2 kilohms. It appeared that I had a leaky capacitor. Disconnecting capacitor C150 caused the voltage to increase at the base of Q16. Measuring from one side of C150 to ground turned up, as you guessed it, a reading of approximately 2 kilohms. Installing a new capacitor restored satisfactory color to the set.

SYLVANIA DO3

Whenever there is a loss of one color there is a possibility that the picture tube is at fault but in most cases this is unlikely. More than likely the problem is due to a defective demodulator stage or a defective component in one of the demodulator stages. On this particular set the picture appeared blue-greenish. The purity checked okay but the screen and drive controls would not allow an overall gray raster. This led me to suspect a defective picture tube. Before I decided to test the tube, I thought I would check the voltages at the pins of the picture tube. The cathode voltages checked okay but the grid voltage from the R-Y demodulator seemed excessively high. Further checking indicated an open peaking coil. This had rendered the R-Y demodulator stage inoperative, allowing a very high positive voltage at the grid of the picture tube. Reheating the solder connection on the coil eliminated the open circuit and restored satisfactory color to the set. Of course, I

had to readjust the screen and drive controls to obtain a satisfactory black and white picture.

ZENITH 25MC36

This set was brought to me by a friend who was an electronic technician in the U.S. Army. He had explained that the set had lost horizontal sync. To correct this problem he had adjusted the horizontal frequency coil but later noticed that he was not receiving the proper hues from the set. Instead of any further troubleshooting he decided to ask me to check the set. After substituting the burst amplifier, the phase detector and the chroma reference oscillator tube with no success, I reinstalled the old tubes.

I then thought carefully about the symptom. He had adjusted the horizontal frequency control. This would, of course, upset the keying of the burst amplifier which in turn would affect the color phase. I decided to readjust the horizontal frequency coil to see if I could correct the hue problem. Readjusting the slug pulled the raster from one side of the screen and centered it. The horizontal frequency coil was obviously slightly off frequency. Pulling the horizontal oscillator back to the correct point allowed proper color sync but the horizontal sync was rather touchy. Substituting a new horizontal oscillator tube did nothing for the problem. Checking, I found one of the horizontal phase detector diodes leaky. Installing a new diode and readjusting the horizontal frequency coil corrected both problems.

You will probably encounter each of these symptoms as you repair receivers. These problems can be solved very quickly if a logical troubleshooting approach is used. The troubleshooting chart that I have provided at the end of the article may be of value to you. This is especially for chroma problems.

BASIC COLOR SYMPTOMS AND THE STAGES INVOLVED

Symptom	Suspected Stages
Loss of one color	Picture tube Color video amplifier Color demodulator (Check drive and screen controls first)
One wrong color	Color demodulator
No color	Color i-f amplifier Color killer 3.58-MHz oscillator Color sync amplifier (Check color killer control first)
All colors wrong	3.58-MHz oscillator Color i-f amplifier (Check hue control first)
Loss of color sync	3.58-MHz oscillator Color sync amplifier Color sync gate

more

Adventures in TV Servicing

J.B. Straughn

Beginners or those thinking of starting to service radios or TVs should not be alarmed by the seeming difficulty of some of the service jobs I describe. These are what are called in the trade “dogs” and are not like most service jobs. After all, it would not be of much interest to report that a set came in and I replaced a defective tube and charged \$15, or that a set came in dead with the tubes lighting up and that I replaced a fuse or an open fusible resistor or a defective circuit breaker to make repairs. In these articles I have described actual cases, telling the symptoms, my thinking (smart or dumb) and how repairs were made and what I charged. In most areas higher charges would be made. This is a poor section of the country and many of my customers are on welfare so I give them a break. (I might say that this works both ways. Once I let one fellow’s wife fish in my lake. In return they kept us supplied with fresh vegetables all summer. She caught a nine-pound bass not long ago!)

So let’s go to some service dogs, and don’t worry—you’ll be able to do just as well as I can and maybe better. These days I don’t have the energy to work eight hours a day and moonlight half the night, as I did in my prime.

RCA CTC 38A COLOR SET

I had worked on this set about a year ago and replaced the horizontal output transformer (flyback). The customer, who is a friend of mine and chief engineer of the local radio station, complained of an arcing sound in the set. Rather than have him bring the set back I loaned him some anti-arc (corona) dope and suggested he apply some to the leads in the compartment containing the base of the high-voltage rectifier tube, as that’s where he seemed to think the hissing noise was coming from. This seemed to work for a while, but a couple of months later he called and said he had lost color. A day later he said the set had lost its raster.

He got a truck and brought the set to my shop, along with a Philco color set belonging to the truck owner. More on the Philco later.

I checked the tubes and found the horizontal output and oscillator tubes to be weak. Replacement did not restore the raster, so I rigged things up so I could measure the grid drive to the horizontal output tube. It was normal, indicating that the horizontal oscillator was working. I discovered that when the owner had applied the anti-arc dope he had cut the plastic cap covering the base of the high-voltage rectifier and thrown it away (I guessed). I inspected all leads and soldering, and they seemed to be okay. I got a new plastic cap, unsoldered all leads and passed them through the hole in the center of the new cap, resoldered and put the cap in place. I didn't really expect this to renew high voltage and it didn't. Next I made point-to-point resistance checks and measured voltages at points I could reach, but found nothing wrong.

If I had not replaced the flyback a year ago, I would have suspected it as being the cause of the trouble. However, I had now gone far enough that it seemed to me that the transformer must have failed again. It looked okay and there were no gobs of melted wax which would have been a definite indication of a defective transformer. At any rate I set up my scope for checking coils and found the transformer was indeed defective. (The scope is an old Conar 250 which can check the horizontal system with the set turned off).

With some feeling that I might be throwing money away (if a part has been installed, the wholesaler is not about to take it back for credit), I purchased a new transformer and installed it. This time I carefully read the instruction sheet that was packed with the part. Don't do as I do, but do as I say and *always* read such instruction sheets! You won't be sorry.

I was very careful in making the installation and wiped the inside of the high-voltage cage as directed to remove all dust and metal particles (there were some). I used a magnifying glass to check each connection and made sure all were smooth with no stray wire leads. I turned the set on and got a beautiful black-and-white picture—no color. I had seen this trouble in a number of similar RCA color sets so I checked the voltages in the transistorized color killer circuit. Sure enough, a defect in one of the transistors was indicated (lack of proper voltages). I got a replacement for this circuit and the ACC transistor, which ties in.

With the new transistors installed, the color killer could be adjusted so there was no colored snow between stations but good color when tuned to a station. I didn't know for sure, but I felt the failure of the flyback transformer just might have been due to careless work on my part so I just charged for my cost as far as this part was concerned. The total bill came to \$62.50 and my friend was pleased. He said it was the best picture he had ever gotten on the set.

PHILCO 21ST90 COLOR SET

This is the set which came in with the RCA just discussed. The complaint was that a fuse had to be replaced about every three weeks. The Sam's folder on the set showed a 0.6-ampere fuse in the horizontal output circuit. I removed the old fuse, which was open, and found it to be rated at only 0.5 ampere. This should not have been enough difference to account for the fuse burning out. Frequently turning a

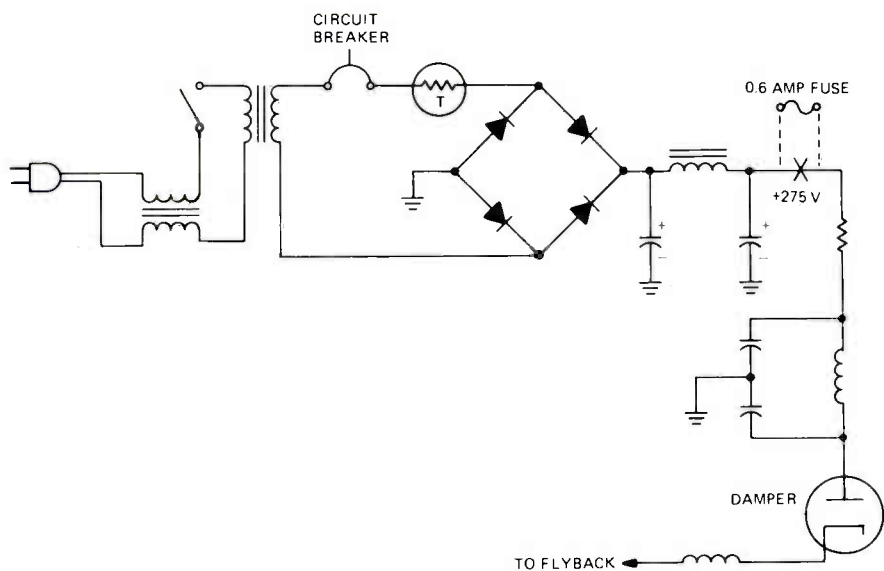

FIGURE 1. POWER SUPPLY AND DAMPER IN PHILCO 21ST90.

set off and then right back on will cause a large surge of current in the horizontal output tube which will blow a resistor or open a circuit breaker.

I studied the schematic and saw that a circuit breaker also protected this part of the circuit (see Figure 1). Also, the fuse was marked on the schematic as not being in all sets—someone at the factory had had second thoughts! This was enough for me so I used the biggest thing handy—a 5-ampere fuse! I told the customer his set was fixed and that if the fuse burned out again I would personally eat it! That was about four months ago and the set is still going strong. I also replaced the horizontal output tube as a precaution and charged \$22.50—everybody happy!

MOTOROLA TS-578YA-13

This set had a number of simple things wrong with it but the biggest problem was that it was dead on UHF. It was such an old set that it had a 2AF4 local oscillator in the UHF instead of a transistor. Figure 2 tells the story—it is the correspondence between me and the tuner repair station.

As you may know, the connector cables that plug into a tuner are sometimes soldered in place. A turn of the plug with a pair of pliers will break the solder connection and let you slip the plug out of its socket. Needless to say, you should always resolder after reinserting the plug in the socket. I failed to do this on this occasion and believe the defective cable caused the diode to blow. The heater current for the UHF oscillator tube had to go through the circuit including the diode, instead of through the defective cable shield to the chassis. You may never

Rte.1, PO Box 267
Shorter, Alabama 36075

July 29, 1974

United Tuner Repair Company
PO Box 42235
Atlanta, Georgia 30311

Gentlemen:

Last week I received from you a UHF tuner which you had repaired. When inserted in the set the tuner did not work. While there is a possibility that the repair was not properly made, I am inclined to suspect the VHF tuner and I am sending both to you for examination and repair.

Please do not charge me again for the UHF job. These tuners are out of a Motorola TS-578YA-13. There is a 2.7K resistor between B+ of the VHF and B+ of the UHF. Also, the heater return of the tube in the UHF is through the signal cable between the UHF and VHF tuners. There is an intermittent open in the shield of this cable. Please replace. This, however, is not the cause of the UHF being dead as I substituted a good cable from another set.

I might add that there seemed to be some kind of oscillation in the VHF when in the UHF position.

Please rush this job as my customer, while understanding, has waited too long for his set. Send UPS collect, or bill me, please.

Sincerely,



From United Tuner Repair:
THE DIODE IN THE UHF TUNER WAS BLOWN--DUE TO THE BAD CONTACT IN SIGNAL CABLE (WE ALSO REPLACED CABLE). BE SURE GROUND IS GOOD BEFORE AC VOLTAGE IS APPLIED TO TUNER. AS A POOR GROUND WILL BLOW DIODE.

IN ORDER TO NEUTRALIZE ALSO REPLACED MIXER & RF TUBES IN VHF, FINE TUNING AND MIXER PLATE COIL.

BL

FIGURE 2.

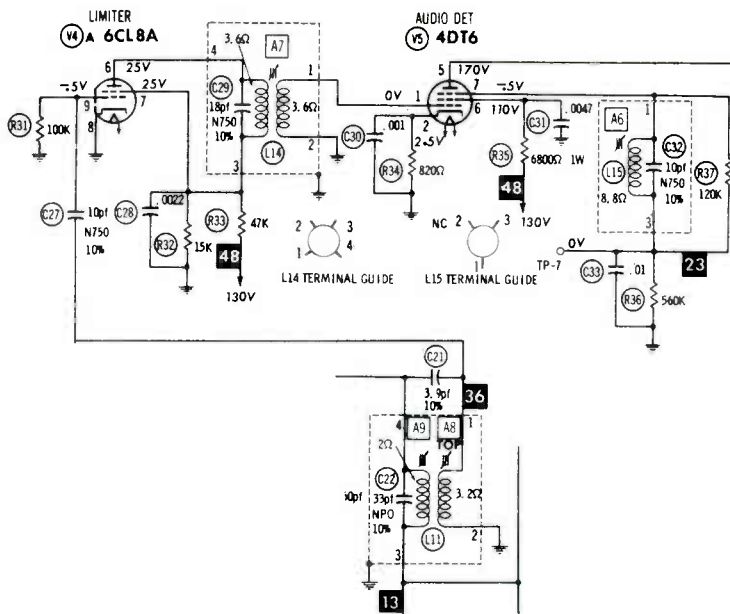

Courtesy Howard W. Sams

FIGURE 3. SOUND SYSTEM OF WESTINGHOUSE HP-3032.

run up against such a situation, as most UHF tuners today are completely transistorized, but resolder all connectors if they show previous signs of having been soldered.

WESTINGHOUSE MODEL H-P 3032

This set came in without raster or sound. Replacing the horizontal output and damper tubes brought in a picture. However, the sound distortion was unbearable. I tried adjusting all slugs in the sound i-f system to no avail. In fact, I over-adjusted the bottom slug in the sound take-off transformer in the belief I was getting an improvement and suddenly the slug slipped out of the grooves at the bottom of the form, inside the transformer shield.

I put the set to one side, but a few days later got up enough energy for what I thought would be a messy job of getting the slug back into its form. I removed the shield of L11, (Figure 3), and was able to see through the mylar tube on which the coil was wound and locate the position of the loose slug. With a little luck, I got the end of the alignment tool into the slug and gradually screwed it back into the coil form. Afterwards I realized that I could have done this without taking off the shield. Anyway, I put the shield back in place and resoldered it to the circuit board.

The same old distortion was still there but you can bet I didn't repeat my former mistake and screw another slug out of its form. I knew there were two other transformers but from the results of the adjustment I had already tried I suspected

the quadrature coil. I studied the tube and parts layout and found I had correctly picked out the quadrature coil from its physical placement with respect to the 4DT6 detector tube.

When I next went downtown I tried to get a set of electrolytics for the receiver as the buzz almost sounded like an open filter. Luckily they had none as this was not the trouble. Adjustment didn't help but I noted as I idly wiggled the coil form of the quadrature coil, that considerable noise was produced. This should not have happened.

I took the set out of the cabinet again to expose the wiring side of the circuit board and removed the shield of the quadrature coil. This didn't show anything, so I removed the coil itself. With the coil on the work bench, I checked it for continuity, and instead of measuring the called for 8 ohms it showed infinite resistance! The coil was open and I found a break in one of the leads where it was supposed to join a solder lug. The wire was not long enough to reach the lug, so I unwound a turn which gave me plenty of length. There were quite a few turns and since the coil inductance was adjustable, I didn't think removal of one turn would matter. I carefully scraped the wire with my pig sticker to remove the enamel insulation and soldered the wire to the lug. The coil now checked okay with the ohmmeter.

Just as an aside, an old-timer at NRI, George Rohrich (he was there when I went to work in 1929), once showed me an easy way to remove enamel from a wire by heating it and then cooling it suddenly by dunking it in alcohol—it works, but on very fine wire you may burn the wire in two when heating it. Today you could use "Freeze Mist" available in spray cans—its real use is to locate thermal intermittents.

When the coil and shield were back in place, I was able to adjust the quadrature coil to get good undistorted sound. I didn't think the raster was bright enough so I turned the set off and removed the shield from the high-voltage compartment to get at the high-voltage rectifier. The diagram showed a 10K resistor between the rectifier output and the picture tube anode, so I got sidetracked from checking the high-voltage tube.

I should have known better, but without discharging the picture tube, I pulled off the plastic cap covering the base of the high-voltage rectifier tube to take a look at the above mentioned resistor. The resistor didn't look burned or anything and I absent-mindedly reached for it and got a nice shock as the picture tube discharged through me! This is not dangerous if you have a good heart, but is shocking to say the least. However, the shock seemed small, so to speak, so I fired up the set and measured the anode voltage of the picture tube. I found only 10,000 volts instead of the 15,000 volts called for on the schematic. A new high-voltage rectifier tube took care of this—you may be sure, however, I don't recommend trying to check voltages with your finger!

I charged \$25 for labor plus the list price of the tubes. The customer was overjoyed with the sound if not with the price. I never fail to marvel how people will put up with and get used to deteriorating picture or sound and then bring you the set only when one or the other finally goes out completely.

TRUETONE MODEL MIC 39128-17

This set could not be made to hold sync horizontally and when I tried to adjust the horizontal hold I found that it had been broken off the circuit board and someone had glued and soldered it back on the board. The slightest movement would open the circuit and the raster would disappear.

I cleaned the glue off the board and called my friendly Western Auto (Truettone) parts distributor in Atlanta, giving the factory part number which I got from my Sam's manual. I received the new part in two days, which was a pleasant surprise, and installed same along with a needed tube or so.

Two weeks later the set came back—no raster. The customer was quite put out as the trouble was exactly the same as before. I was put out too. I shook the cabinet and heard something rattle inside. I suspected the set had been dropped and the tube knocked loose. However, when I got around to the set and removed its back there were no tubes out of their sockets.

A neon bulb on the end of a fiber tube held near the high-voltage rectifier tube did not glow, as it would have done in the presence of the high-voltage AC. I couldn't pick up a glow from the horizontal yoke winding showing there was no sweep voltage, also no glow when placed near the envelope of the horizontal output damper tube. With the tube removed to expose the socket connections, there was normal voltage at the pentode screen and at the damper plate. I got out the schematic (Figure 4) and made point-to-point resistance measurements—nothing wrong.

I suspected a short or leakage between the vertical and horizontal windings on the yoke. I disconnected the vertical leads of the yoke at the terminal strip on the yoke and checked from them to the horizontal winding—the resistance was infinite as it

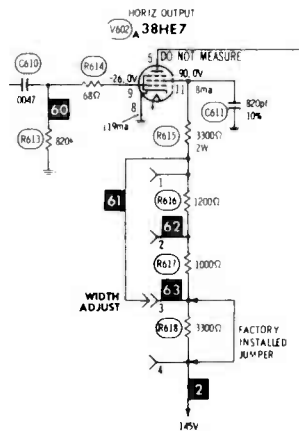

Courtesy Howard W. Sams

FIGURE 4. HORIZONTAL OUTPUT TUBE OF TRUETONE MODEL MIC 39128-17.

should have been. I thought the flyback might be bad and checked it with my scope, after reconnecting the yoke—nothing wrong here. I began to wonder how to tell the customer his set was no longer worth fixing but decided not to give up just yet. I put it aside for the time being and worked on something easier.

When I got back to the set again I slid the circuit board out, so I could get at its bottom while the set was on. I had to remove the anode lead from the picture tube as it was too short to let me turn the board over.

I started checking voltages and found no horizontal drive voltage ($-DC$) at the grid of the horizontal output tube. This led to a close inspection of the horizontal oscillator circuit. The scope showed it to be working okay and that the proper signal was present at the grid of the horizontal output tube!

Checking voltages again on the horizontal output tube, I noticed a strange buzzing noise from the high-voltage compartment, containing the flyback transformer, when the test prod was on the “grounded” cathode lug of the output tube. The noise stopped when the prod was touched to the chassis. I turned the set off and wiggled the tube in its socket, noting movement at the cathode terminal. The cathode lug on the socket was loose on the circuit board and making contact only when pressed by the test probe! I also found the same condition at the control grid terminal lug.

I got my wife to hold the board in a horizontal position and resoldered all connections on this socket. Don't try to solder on a circuit board when it is in a vertical position—solder runs, and not only may it not stick at the desired point but may create a short to some other segment of the board.

I shook the cabinet and out fell a large door key, which some kid, probably, had pushed down through the louvers on the back of the cabinet. My guess is that someone turned the set upside down and tried to shake the key out “like a piggy bank.” This must have caused the key to hang up where it could not be seen and at the same time the 38HE7 output tube fell out of its socket. Whoever put it back in struggled and broke the solder connections at the cathode and control grid.

If you wonder why the point-to-point resistance measurements didn't show up the trouble, consider the circuit in Figure 4. When I pushed the test probe against the “open” circuits they closed and proper continuity was shown on the ohmmeter. No $-DC$ grid voltage was measured because both the control grid, pin 9, and cathode, pin 8, circuits must be closed before the grid-cathode can rectify the applied sweep signal. If either is open there will be no rectification and no $-DC$ grid voltage, even though you can measure signal voltage at the control grid when the scope probe closes this circuit. I suppose I could have figured this out ahead of time and saved a lot of needless testing.

I charged only \$10 for the repair and return of the missing key, as the set had only recently been fixed. The key, of course, is what made the customer willing to pay—something they did!

This reminds me of another recent job where a set came back with the complaint of picture but no sound. Since there was no sound at all I suspected the loudspeaker—some sound is usually heard, at least when a set warms up. I proved the loudspeaker to be bad by the fact that no click was heard when the low range ohmmeter probes were touched to the voice coil terminal strip lugs. This should have caused a current flow through the voice coil and a sharp cone movement, resulting in an audible click. On removing the loudspeaker I found that one of the kids of this house apparently did not like what someone was saying on a program and had decided to kill the voice. This had been done by stabbing the speaker through the louver in front of the voice with a knife or something, and one voice coil lead, where it attached to the cone before going to its solder terminal lug, had been severed—the voice coil was opened and no more sound!

I can't blame him too much—maybe he was listening to “The Mouth” on a Monday night football game. I don't do anything this drastic—I just turn the volume all the way down and watch the game in blessed silence.

I got a new speaker from my friend the wholesaler who had a sale going on at \$1.25 per speaker and installed same. I charged \$15.50 for this one and saved the old speaker to show the mother, hoping someone would get their tail warmed! Does this make me a sadist?

RCA KSC I95P

I have been servicing this set for years because the customer likes it and wants to keep it running. This time the set was dead so I took off the back and plugged it in. There on the picture tube base was a tube brightener which I had forgotten I'd put there. By turning the brightness control back and forth a dim raster would momentarily show up, but it was much wider at the base than at the top. Such a raster shape always indicates a defective yoke and the dimness plus the brightener pointed to a bad picture tube. Therefore, I had both a bad yoke and a defective 23-inch black-and-white picture tube. I was surprised when the customer agreed to an estimate of between \$70 and \$80 to fix it. I wondered if I had quoted too low as I figured the tube would cost around \$35 and the yoke about \$15. Because there are not so many in use, a 23-inch tube costs more than a 25-inch tube!

I went to the wholesaler I usually deal with and found he did not have a 231HFP4 tube in stock. I like to deal with him on picture tubes as he handles “Dumonts,” which cost less than the big-name brands and serve the purpose well. I got him to call a competitor and found that he had a replacement tube. My friend didn't have the right yoke either, but had a \$13 Stancor which he thought was close enough. I went to the other firm and had to pay \$49.50 for the tube. However, I would get back \$8 on return of the old dud. There I had about \$54.50 tied up and I was glad I at least had quoted \$80 for repair.

I installed the tube and yoke and the picture was okay except for the fact that it was badly bowed or pincushioned. I took the new yoke off to look it over and found out it had no magnets at the top and bottom. The old yoke had them, so I dug out the old magnets and slipped them into the cups present in the new yoke

form. When I tried the set out again the tendency to pincushion was greatly reduced. I decided the customer could live with the slight bow since it was only noticeable if you knew about it.

The set worked excellently on VIIF but to my dismay was dead on UHF. I don't do much work on tuners, preferring to send them off for repair. In this case, however, I couldn't see putting out any more money.

Everybody knows that the first thing to do is to check supply voltages but instead I decided the crystal diode just had to be bad. Due to the physical arrangement of the tuners, I had some difficulty getting the cover off the UHF tuner.

At last the diode was exposed. I took it out, noting its polarity and checked it with my ohmmeter. It checked okay, so I put it back and there I was! About then I remembered the power supply, which consisted of three resistors in series from B+ to ground. They were sitting in plain view on top of the UHF tuner. I found plenty of voltage going to the network and voltage from the first junction to chassis. However, there was no voltage at the junction of the last two resistors which fed into the UHF tuner. The second resistor had a value of 15 kilohms and was half a watt. When I fingered it the body broke in two and I had found the trouble! A new resistor restored voltage to the UHF tuner and the set played like new on all stations in the area. All this just goes to show that giving a firm estimate can be a dangerous thing, for most of the time you don't know what repairs will cost until the job is completed.

SEARS ROEBUCK MODEL 5024

I took on this modern transistorized TV against my better judgement after learning another serviceman had worked on it for over a month before giving it up as a bad job. The set was dead, but had a good raster, showing the sweep circuits and high-voltage system as well as the low-voltage supply were okay.

In a case of this sort, a logical place to start is the tuner. Failure here (or in the i-f and video) would kill both sound and picture. I decided to check the tuner with my substitution test tuner. The i-f signal cable lead from the set tuner was soldered at both ends and would be hard to unsolder—a distasteful job if the set tuner turned out okay. I hooked up my test tuner and clipped its ground lead to the set chassis. The hot lead I clipped to the metal shank of a thin-bladed screwdriver. I poked the blade of the screwdriver down into the works so it touched the lug to which the i-f cable was soldered. I turned things on and sure enough got a good picture, showing that the set tuner was defective.

Now I found that there was no sound at all. Looking around some more showed that the speaker was installed but not connected. At this time I pulled the schematic and looked over the audio section shown in Figure 5. I could see where some poor devil had worked on the audio output with a vengeance and had then thrown up his hands in despair and had just given up. One lead of each resistor in the output stage had been disconnected as had one lead of each capacitor. New

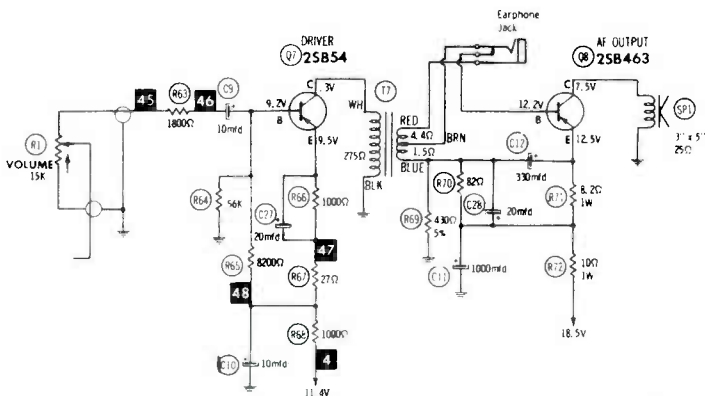

Courtesy Howard W. Sams

FIGURE 5. AUDIO SECTION OF SEARS MODEL 5024.

resistors and capacitors had been tacked into the circuit as a check on all parts and I could see that a new transistor had been installed.

In noting that the speaker was disconnected I also looked at the schematic and here is where I was lucky. The schematic showed the voice coil had a resistance of 25 ohms, which is usual in this type of circuit. I checked it with my ohmmeter “just to see” and it measured a little less than 2 ohms, about right for an impedance of 2.5 ohms.

I looked up the replacement in Sam’s Manual which listed a Quam part number 35AO5Z25. The number on the new Quam speaker was 35AO5Z2.5. Off I went to the local wholesaler who handles Quam speakers and a search of the catalog did not show a 25-ohm speaker—only the 2.5-ohm unit. Nobody had a 3” by 5” 25-ohm speaker. I fear that if I had had to purchase a replacement I would have probably have wound up with the 2.5-ohm unit and a badly bruised ego.

It turns out that only Sears carries the proper replacement and, as they will only sell at retail, I got my customer to buy one for around \$6.50 when he had agreed to my \$35 estimate for repairs. When the new speaker came in and was installed, the set had sound and picture using my substitute tuner. I sent the set tuner off for an overhaul and thus had the set delivered to the customer in another week. The tuner repair cost me \$17.60 and I received the \$35 plus the 2.5-ohm speaker as well as the resistors and capacitors left by the other fellow. I didn’t make a lot, but I only spent a couple of hours of actual service time and learned something at the same time.

Reader Exchange

FOR SALE: Five-inch Model 250 oscilloscope like new, no scratches, used very little. Asking \$50 or best offer. Contact James W. Heil, 3809 Cynthia Drive, Pittsburgh, Pennsylvania 15227.

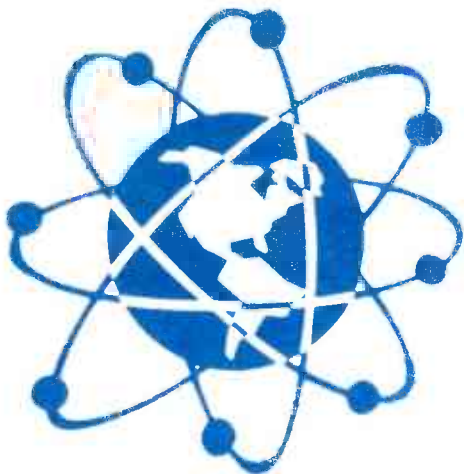

HAM NEWS



By Ted Beach **K4MKX**

Welcome to 1975! It hardly seems possible, but another year is upon us and hopefully it will bring to all of you better things than the past year. Not that last year was so bad, but I have just been reading over some mail and some of the questionnaires returned by you guys out in "readerland," and I must say that I am a bit down in the dumps.

The big reason is that many of the non-ham readers do not appreciate your Ham News, and think that it is a waste of time. Well, I happen to like a lot of different magazines, and while I do not classify myself as an "audiophile" or a "CBer" or any other category of electronic nut, I still find reading about these various topics of the utmost interest and concern. This is because mainly I am interested in electronics as a whole, and not just Ham radio. I want to know what is going on in medical electronics, and space communications and data processing and everything else that has to do with electronics. Amateur radio is just one facet of this gem of ours.

Sure, we have our own jargon—but this is certainly not meant to exclude anyone. It's lots of fun, and believe me you become a very well rounded individual in electronics if you keep up with all that is going on. Did you know, for instance, that we amateurs have our own communications satellite? In fact, as of now we have TWO satellites in orbit, both operating quite nicely.

Well, it takes special people to undertake a satellite communications program, and not just a bunch of "nuts." There are many Ph.D.'s and ordinary Joe Blows involved, but the overall program was put together, developed, financed and put into service by amateurs; people just like you and me. And that's what it's all about as far as I'm concerned—people interested in electronics doing their own thing.

At any rate, for those of you who do not understand what Ham Radio is, all I can say is "Try it—you'll like it."

So much for the soapbox. Now let's

Vince	W2PFK	A	Buffalo NY
W.L.	WB5HMB	T	Garland TX
Jack	WN5MON	N	Tulsa OK
Dale	WN6BYS	N	Sacramento CA
John	WN6GSN	N	Artesia CA
J.M.	WB9LMW	G	Champaign IL
Ron	WN90VW	N	Chicago IL
Lee	WN0NIS	N	Ft. Leonardwood MD
Jean	VE2DNG	—	Sherbrooke PQ, Can.
Stan	WA3VWK	G*	Arnold MD
Bob	WN9OGR	N	Peoria IL

* Just upgraded—congratulations!

see who we've heard from since last time.

As usual, the first nine calls listed above are students or graduates of the NRI Course for Amateur Licenses. The next to the last one is from our Communications Course, and Stan writes: "Will now concentrate on FCC First Class with radar and then, who knows, try for the Extra. With your fine training, I know I'll be prepared." That's the kind of letters we like to get!

To continue on with some comments by the second group, WN9OGR asks how my VHF bridge/wattmeter works on the HF bands as reported earlier. Well, Bob, I don't really know. However, the basic circuitry for the two Heath instruments is the same, and having tried the meter into a known 50-ohm dummy load at both frequencies I know that the SWR was correct (1:1) and therefore I assumed the power indications were also pretty accurate on the lower frequencies. At least they were well within reason considering the power input of the Ranger. After all, who am I to fight it? Anyway, until I find out differently I will continue to believe the meter on

the low bands as well as the high bands. In the meantime I have drafted a letter to Heath to ask them about this. Since they are in the business of selling equipment, however, I firmly expect a reply that will tell me the VHF unit will not work at the lower frequencies. We'll keep you informed.

Maurice, VE2SV, wrote and expressed an interest in the synthesizer project of mine, wanting to know where I had gotten the schematic. Well, Maurice, the circuit that I ended up with is one that I designed myself after reading quite a lot in the many amateur magazines about the subject. The first one was in "73" magazine of February, 1970 by W2EUP, Gil Boelke, who now manufactures a commercial unit, the GLB Channelizer. I don't have the other magazines right at hand, but there was a two-part article about two years ago in "QST" and one or two others in "Ham Radio." When I find these, I'll drop you a line in the mail, Maurice.

We also heard from two ex-amateurs who are now working on getting re-licensed. Duane, who held tickets from 1953 to 1969 is cramming again, and has held WN3WBJ, WRWBJ and

WA4UMA in that period of time.

Charles was originally licensed as W3FPE and then was sent to the west coast and let his ticket lapse. After a bout with several illnesses, he was forced to retire and move to Arizona where he decided to enroll in the Amateur course and try for his ticket all over again. Good luck to you both.

Most of the rest of the names in the list this time came from our lesson grading section and did not have very much information with them. WN5MON, however, tells us that he got his recently issued Novice license as a direct result of his NRI studies and that he will write more "as soon as I learn to type." Don't wait for that, Jack. Let us hear from you.

Lee, WN0NIS, writes that he has really been working on the code and that he can copy 18 wpm solid. However, it seems that he has been neglecting his

theory and will have to get cracking on it in order to take the General test.

VE2DNG writes from Quebec that his station at present uses a Heath DX40 transmitter and a Realistic DX150B receiver. Jean did not say what type of antenna(s) he has, but we're sure he puts out a decent signal into the States.

And last but not least, we received word from Herman Schemm that he had gotten notification that he had passed his General exam. Herman has an APO address so that is quite an accomplishment. Congratulations, Herman.

Let us hear from you—we can't always write directly to answer questions, but we will always reply in this column to all people who write in. Have a nice year and we'll BCNU.

Very 73—Ted—K4MKX

Job Ops

BUSINESS OPPORTUNITY: Mac TV Service in Frankfort, Indiana is to be sold due to the death of the principal partner. This business is offered complete with all stock and equipment necessary to operate for a total purchase price of \$15,000. Financing available to qualified parties. Specific licensing arrangements will be made to satisfy your needs. For further information, contact Mrs. C. L. McMullen, 554 Elmwood Drive, Frankfort, Indiana 46041.

JOB OPENING: Technician with four years experience in maintenance of complex electronic equipment including one year specialized in the repair and calibration of test equipment or two years of specialized experience in the repair and calibration of a wide variety of electronic test equipment. Contact International Electronics Corporation, APO San Francisco 96301.

HELP WANTED: Engineering personnel capable of laying out and integrating radio and navigation systems in both helicopter and fixed-wing aircraft. Contact Oxford Avionics, 288 Christian Street, Oxford Airport, Oxford, Connecticut 06483.

JOB OPENING: Lab technicians familiar with state-of-art digital and analog logic circuits having practiced assembling and debugging prototype circuits. Contact Telectro Systems Corporation, 96-18 43rd Avenue, Corona, New York 11368.

NRI HONORS PROGRAM AWARDS

For outstanding grades throughout their NRI courses of study, the following September/October graduates were given Certificates of Distinction along with their NRI Electronics Diplomas.

WITH HIGHEST HONORS

Larry L. Abney, Florissant, MO
Bruce H. Barr, Bradenton, FL
Herbert W. Buchanan, Cold Springs, NY
Willard Travis Burney, Lincoln, NE
Herman Davis, Raleigh, NC
Joseph D. DelPrincipe, Sterling Park, VA
Leroy J. Joppa, Aiea, HI
Blagoj Jordanov, Detroit, MI
Dennis R. LaBoyne, Biloxi, MS
Gary A. Oliwa, Shelton, CT
Walter E. Perrine, Elko, NV
John J. Schaeffer, Westwood, NY
Harold M. Schwab, Jr., Charlotte, NC
Michael E. Scott, Anchorage, AK
Wayne Chris Williams, Edmonton AB
Canada

WITH HIGH HONORS

Barry E. Abidor, Van Nuys, CA
James R. Akins, Norcross, GA
Charles R. Ayers, Datona Beach, FL
James Edward Baldwin, APO New York
Robert W. Batchelder, Slingerlands, NY
Paul C. Beck, APO San Francisco
Richard W. Berthiaume, Manchester, NH
William Beshore, Jr. Grandview, MO
Thomas G. Bowser, Sturgeon, PA
James E. Buchanan, APO San Francisco
George Burke, Jr., Lexington, IN
James M. Carden, Tulsa, OK
Henry Warren Casidy, New Bern, NC
Gerald D. Castleman, Anaheim, CA
Bart G. Casty, Houston, TX
John Cegar, Bronx, NY
Michael J. Cipar, Endicott, NY
Floyd D. Colombatto, Jr., Oak Lawn, IL
Harry W. Conrad, Sept Iles PQ, Canada
Charles L. Daniel, Jacksonville, FL
William H. Davis, Kingston, OK
George Demas, Gambrells, MD
Emerson T. Dixon, Jessup, MD
Klem D. Drozdowski, Pease AFB, NH

Adam R. Durant, Lafayette, LA
Ernest Faulkingham, Dover Plains, NY
Lawrence T. Ferguson, Jr., Brady, NE
Leon James Fitzgerald, Bedford NS, Canada
Michael Fitzpatrick, Norwood, MA
Ralph Lee Flecker, Huntsville, AL
Joel D. Freeman, Grundy Center, IA
Bruce B. Fuller, Centereach, NY
James M. Fullerton, Independence, MO
Doyle Wayne Gilstrap, Petaluma, CA
Clifford P. Grupe, Ridgewood, NJ
Ronnie L. Hatcher, Elizabethtown, KY
David W. Hathaway, Leavenworth, KS
Rex Alan Hauth, Columbia City, IN
Martin R. Hemberger, North Bergen, NJ
Barton R. P. Holcomb, San Diego, CA
James W. Jelinek, Lancaster, OH
Joseph Johnson, Jr., Montgomery, AL
John King, Guayaquil-Ecuador
Stephen Kupchack, Oceanside, NY
Frank LaBar, Nazareth, PA
S. L. Lamkin, Missouri City, TX
David A. Levine, Westbury, NY
Hewitt HSU-FU Lo, Washington, DC
James W. Lusk, Camp Springs, MD
John C. Magenis, Cheyenne, WY
Royce W. McAdams, Cleveland, TN
Steven M. Melfi, FPO New York
James Miller, Middlebury, IN
Daniel C. Millsaps, Mooresville, NC
Leo P. Mosby, Jr., Brighton, IL
Arthur Jack Musgrave, Framingham, MA
Robert T. Nemes, Orlando, FL
Gary A. Ouderkirk, Klamath Falls, OR
Ronald M. Parsons, Glen Burnie, MD
Joseph H. Pedrick, Ritchie, MD
William P. Pollins, Jr., Warwick, RI
Harold Raeker, Minneapolis, MN
Anthony J. Rappazzo, Essex, MD
Jon A. Rick, Battle Creek, MI
Carl Roberts, Jr., Simpsonville, MD
Lonnie B. Roberts, Hampton, VA
Pablo M. Rubio, Lancaster, CA
Jerry D. Ruser, Winona, MN
Joseph W. Russell, Colona, IL
Burt Shulman, Brooklyn, NY
Leonard E. Sosnovske, Gresham, OR

Richard N. Steinmetz, Temple, AZ
Harry H. Stewart, Beaverton, OR
David G. Storer, San Pedro, CA
George A. Vilches, Tampa, FL
Lloyd C. Watson, Scottsdale, AZ
James S. Weimer, Waynesburg, PA
Glenn R. Wright, Abilene, TX

WITH HONORS

Anthony F. Albright, Carlisle, PA
Alfred Algeria, III, Bayonne, NJ
Robert D. Allen, Longview, WA
Bobby G. Anderson, Vacaville, CA
Horace C. Atkins, Jr., Lawton, OK
Raymond P. Baum, Staten Island, NY
Barry F. Bealick, Bronx, NY
John Egbert Bishop, Memphis, TN
Robert E. Brooks, Marietta, GA
Edwin Bryant, Butlerville, IN
George Buchanan, Garland, TX
Donald G. Burbank, Broomfield, CO
Richard A. Bye, Oaklawn, IL
Clive W. Cannon, Fortson, GA
James M. Carron, Forestville, MD
Charles F. Chase, Palmer, AK
William F. Collins, Waltham, MA
Robert L. Courtney, Alexandria, VA
Leroy F. Dahm, Waukegan, IL
Otis P. Dufour, Chalmette, LA
Howard J. Edwards, Fort Sill, OK
Dale V. Erickson, Sherburn, MN
Edward G. Faris, Jackson, MI
Paul Fassin, Kingston, Australia
Henry J. Felkey, Columbus, OH
T. C. Ferdaszewski, Tacoma, WA
Jose Jaime Ferreira, Espanola ON, Canada
Richard C. Fitzpatrick, Cottageville, WV
Steve A. Fuesting, Effingham, IL
Alan F. Gaffaney, Mission Viejo, CA
Richard E. Gerbracht, Bergenfield, NJ
I. R. Gordon, San Diego, CA
Roby L. Gray, Jackson, MS
Thomas L. Greenbaum, Stamford, CT
Claude T. Greeson, Greensboro, NC
Hires J. Hall, Baltimore, MD
Robert Ray Hamilton, Jacksonville, NC
James G. Harding, Linthicum, MD
Wade H. Harper, Brevard, NC
Louis W. Hecht, APO New York
Thomas J. Herlein, APO New York
Milo L. Hewitt, Carmichael, CA
Joseph L. Hick, Fort Lauderdale, FL
Arnold Highbarger, Jr., Ben Lomond, CA
Charles L. Holley, APO New York
Glenn Ray Hooks, Charlotte, NC
Ronald M. Hopp, Roger City, MI
Michael H. Howey, FPO New York

Jude K. Huckaby, Eunice, LA
Arthur T. Hursey, Douglas, GA
Gary Jefferson, San Leandro, CA
David C. Jenkins, Biloxi, MS
Ward L. Jiskra, Riverhead, NY
Philip H. Johannes, Mill Valley, CA
James Leon Johnson, Fulton, MO
Albert J. Kern, Philadelphia, PA
Philip Klaski, Brattleboro, VT
Robert M. Kmieciak, FPO Seattle
Vernon W. LaFavor, Groton, NY
Robert J. Landry, Hooksett, NH
Charles B. Lang, APO New York
Ronald Laskowsky, Arlington, VA
Jonathan E. Lawrence, Lynchburg, VA
Alvert R. LeBoeuf, Sturbridge, MA
Samuel I. Leibell, Toronto ON, Canada
Robert D. Lerdahl, Madison, WI
Richard B. Lessard, Berkley, MI
William R. Lowe, River Edge, NJ
John William Lunsford, Detroit, MI
Charles R. McKay, Milwaukee, WI
Steve J. Mickel, San Diego, CA
Joe Muller, Springdale, OH
Phillip E. Multop, Everson, WA
David L. Nelson, Manassas, VA
William N. Nusbaum, Ponce, PR
Thomas W. Nizzi, Landover Hills, MD
Joseph J. Oaster, Philadelphia, PA
Gurudas P. Pai, Washington, DC
Ricardo I. Peart, Chapultepec, Guadalajara, Mexico
Eugene D. Pilipanko, Minneapolis, MN
Donald E. Plumb, Jr., San Diego, CA
Thomas M. Raffy, APO New York
Christian Rampin, North Bellmore, NY
Arthur Ratz, Gulfport, MS
Bernard J. Reckman, Jr., Rockville, MD
Dale Rollins, Sacramento, CA
Robert Schieferdecker, Cambridge, IL
William B. Severe, III, Manassas, VA
Howard Eugene Shaffer, Greencastle, PA
Willie Eugene Simpson, Misenheimer, NC
Richard D. Sivils, Crossett, AR
Christopher Solida, Bald Knob, AR
Robert C. Spackman, Salt Lake City, UT
Harvey J. Steinfeld, Rockville, MD
Gus T. Stephanos, San Diego, CA
Ronald J. Stevens, Franklin Park, NJ
Richard C. Storms, FPO San Francisco
Norman Tauchen, Woody, CA
Ira M. Turner, Rose Hill, KS
Edward W. Verner, Palos Verdos Peninsula, CA
George Watson, Richmond Hill, NY
Robert J. Watson, Jr., Richmond Hill, NY
Robert D. Webster, Oak Run, CA
Dwight H. Wright, Litchfield, IL
Richard James Young, Middletown, RI

DIRECTORY OF ALUMNI CHAPTERS

CHAMBERSBURG (CUMBERLAND VALLEY) CHAPTER meets at 8 p.m., 2nd Tuesday of each month at Gerald Strite's TV-Radio Service Shop, RR2, Chambersburg, Pa. Chairman: Gerald Strite.

DETROIT CHAPTER meets 8 p.m., 2nd Friday of each month at St. Andrews Hall, 431 E. Congress St., Detroit. Chairman: James Kelley, 1140 Livernois, Detroit, Mich. 841-4972.

FLINT (SAGINAW VALLEY) CHAPTER meets 7:30 p.m. second Wednesday of each month at Andy's Radio and TV Shop, G-5507 S. Saginaw Rd., Flint, Michigan. Chairman: Larry McMaster, (517) 463-5059.

NEW YORK CITY CHAPTER meets 8:30 p.m., 1st and 3rd Thursday of each month at 199, Lefferts Ave., Brooklyn, N.Y. Chairman: Samuel Antman, 1669 45th St., Brooklyn, N.Y.

NORTH JERSEY CHAPTER meets 8 p.m., 2nd Friday of each month at The Players Club, Washington Square. Chairman: George Stoll, 10 Jefferson Ave., Kearney, N.J.

PHILADELPHIA-CAMDEN CHAPTER meets 8 p.m., 4th Monday of each month in RCA Building, 204-I, Route 38 in Haddonfield Rd., Cherry Hill, New Jersey 08034. Chairman: Joe Szumowski.

PITTSBURGH CHAPTER meets 8 p.m., 1st Thursday of each month in the basement of the U.P. Church of Verona, Pa., corner of South Ave. and 2nd St. Chairman: George McElwain.

SAN ANTONIO (ALAMO) CHAPTER meets 7 p.m., 4th Thursday of each month at Alamo Heights Christian Church Scout House, 350 Primrose St., 6500 block of N. New Braunfels St. (3 blocks N. of Austin Hwy.), San Antonio. Chairman: Robert Bonge, 222 Amador Lane, San Antonio. All San Antonio area NRI students are always welcome. A free annual chapter membership will be given to all NRI graduates attending within three months of their graduation.

SOUTHEASTERN MASSACHUSETTS CHAPTER meets 8 p.m., last Wednesday of each month at the home of Chairman Daniel DeJesus, 12 Brookview St., Fairhaven, Mass. 02719.

SPRINGFIELD (MASSACHUSETTS) CHAPTER meets at 7 p.m. on the second Saturday of each month at the home of Chairman Art Byron.

TORONTO CHAPTER meets at McGraw-Hill CEC, 330 Progress Ave., Scarborough, Ontario, Canada. Chairman Branko Lebar. For information contact Stewart J. Kenmuir (416) 293-1911.



NORTH JERSEY HEARS TALK BY CHAIRMAN GEORGE STOLL

George Stoll, a part-time TV repairman, gave a talk on troubleshooting, using tapes, and described various troubleshooting methods for black-and-white and color TV receivers. The tape contained information on picture tubes, high-voltage circuitry, i-f circuitry, and brightness controls. This was a very enjoyable presentation and much information was gained.

FLINT-SAGINAW CHAPTER HEARS EXECUTIVE SECRETARY

The Flint-Saginaw Valley chapter opened their Fall meeting with a lecture by Tom Nolan concerning the interpretation of oscilloscope patterns. The Executive Secretary wishes to thank Mrs. Jobaggy for her wonderful luncheon which she always prepares each year when he arrives.

At the following meeting the chapter continued waveform analysis similar to that which Tom had introduced at his yearly visit earlier.

NRI AA OFFICERS

Thomas Schnader.....	President
Richard G. Moore.....	Vice President
Homer Chaney.....	Vice President
Angelo J. Colombo...	Vice President
William D. Harris.....	Vice President
Tom Nolan.....	Exec. Secretary

Alumni News

At the October 30 meeting, work was done on an RCA color set which had a ghost in the picture. After delving into the tuner and i-f section, the trouble turned out to be an open diode in the video section but the hunting was very appropriate for the Halloween season. The meeting also produced an NRI student enrollment and the Saginaw Valley Chapter gained a new member, Larry L. Myers. Welcome to the chapter, Larry, and we will help you in every way we can.

SPRINGFIELD CHAPTER ENTERTAINS PROSPECTIVE STUDENT

At the September meeting, Executive Secretary Tom Nolan demonstrated the new Conar Model 255 oscilloscope.

Being a prospective student, Mr. Joseph Pelzarski was invited to attend the October meeting and by meeting the members the chapter hoped that he would decide to enroll in the NRI Course.

Having had a pacemaker inserted in his chest recently, he gave a very interesting talk on its benefits and the



Executive Secretary Tom Nolan at the Southeastern Massachusetts Chapter.

cautions to be observed around electricity, high voltage, and radiation. This was a very out-of-the-ordinary presentation and the information was interesting to all the membership.

PITTSBURGH CHAPTER HOLDS BULL SESSION

At the October 3 meeting, George McElwain, a technician for General Electric, Thomas D. Schnader, TV technician, and James L. Wheeler, in-



Two members of the Southeastern Massachusetts Chapter work out a problem posed by Tom Nolan on his recent visit.

dependent service technician conducted a general bull session.

Many of the various problems that these gentlemen have run into over the years were brought out in the meeting and discussed. A considerable amount of information was presented and the membership departed with a lot more knowledge than they had expected.

At the November meeting, William Sinclair, the field service supervisor for GE Corporation gave a talk on the 17" YA Model color TV receiver. He described the new circuits as well as some of the faults that had developed. He also showed us how to dismantle the receiver. It has a number of circuit boards that are easy to take out and replace (similar to the Motorola Quasar). This set almost seems to be a pleasure to service.

The chapter is planning on the usual annual Christmas party at its December meeting. Also, Mr. Sinclair has asked for a come-back date for next year.

We are also expecting a similar program in the future from Zenith Corporation.

SAN ANTONIO CHAPTER VIEWS TRANSISTOR FILMS

At the September 26 meeting the chapter finished a series of films on transistors. The last two films were on proper methods of in-circuit measurements with and without power. Also discussed were methods of using heat shields to protect the transistor diode while making repairs or testing where the soldering iron is being used.

At the next meeting we will have information on traveling-wave components. At the October meeting, Ted Walker will bring us troubleshooting information and he is beyond doubt one of our best electronic lecturers.

DETROIT CHAPTER ENTERTAINS EXECUTIVE SECRETARY

At the October 10 meeting Tom Nolan, the Executive Secretary of NRI AA, gave his annual talk on using the oscilloscope with a demonstration of the new Model 255 Conar triggered scope.

Tom described the use of the proper probes when using the oscilloscope. He cautioned that without the proper probe it was possible to detune the circuits and actually look at wrong information. After a brief question and answer period, coffee and sandwiches were served compliments of Mr. Oliver and Mr. Cope.

At the November meeting Mr. Nagy showed a 20-minute film from the General Motors library entitled "About Decibels." The movie showed various units for measuring the loudness of sound from the smallest to the loudest detectable by the human ear. A very interesting and enjoyable film.

Chapter Secretaries are urged to turn in their reports of Chapter meetings promptly.

TOM SCHNADER NEW PRESIDENT OF NRI AA



Thomas D. Schnader

Now that the election results are in, Thomas Schnader has emerged as the new President of NRI AA for the year 1975.

Tom was born on May 16, 1919 in Reading, Pennsylvania. He was brought up in Berks County, Pennsylvania and Reading was the county seat. He attended public schools in that county.

As the family traveled quite a bit, when World War II came along Tom found himself in a shipyard on the Ohio river employed as a welder. However, Tom could not see a future in that type of work after the war was over, and he decided to study radio with the National Radio Institute (there were no TV courses in those days). Tom graduated on November 13, 1946 and along with his regular job had a part-time shop where he repaired radios until TV did come along.

He still was in the radio and TV repair business until August of 1951 when he started working full time as a TV repairman. That has been his job ever since and he brings a wealth of knowledge to his new position as President of NRI AA.

Congratulations on your election, Tom, and we know you will make a fine president of the NRI AA.

We also extend our congratulations to the men who have been elected to serve as vice presidents for the 1975 term. They are Richard G. Moore of North Grafton, MA, Homer Chaney of Branson, MO, Angelo J. Colombo of Philadelphia, PA, and William D. Harris of Greensboro, NC.

Reader Exchange

FOR SALE: Various electronic test instruments for sale. Contact William D. Shevtchuk, 1 Lois Avenue, Clifton, New Jersey 07114.

FREE OFFER: Twenty-five Sams Photofact folders, each one complete, clean and in its original envelope. Numbers 102, 110, 112, 122, 134, 135, 172, 208, 210, 310, 366, 384, 387, 392, 395, 409, 471, 593, 609, 611, 638, 639, 681, 787, and 808. Contact Joseph F. Tuder, 5637 Pioneer Drive, Baltimore, Maryland 21214, or telephone 254-8910.

A SPECIAL OFFER TO SHIPPED DIRECT

SAVE 10% ON THE

Note: A 5% discount is given on individual item orders. Use the Journal order blank.

Get started in electronics
with these 5 instruments
and save \$56.60...

Model 1403

3" Solid State Oscilloscope

ALL 5 FOR
\$509.40



Ultra-compact and light-weight—truly a "Mini-Scope"
Sharp, bright trace
DC amplifiers on both axes

\$566.00 VALUE

\$509.40 Your Cost

\$56.60 You SAVE

Here's a valuable "member" of your B & K "Starter's Bench—the Model 1403 "Mini-Scope." Highly reliable, rugged, and so compact, you'll want to take it with you wherever electronics takes you! It's great in the lab, on the service bench, in the field. You'll like the steady, bright patterns; the smoked acrylic graticule that enhances the trace sharpness; the ease of use; the rugged dependability.

Bandwidth is DC to 2 MHz; direct-deflection terminals provided for waveforms up to 150 MHz. Uses latest wide-angle CRT. It's 100% solid state and weighs only 8½ pounds. Has 3-wire grounded AC line cord.
NET EACH: \$189.00

SPECIFICATIONS

Vertical Amplifier

Sensitivity: 20 mV/cm or better. **Response:** DC to 2 MHz; AC, 2 Hz to 2 MHz. **Input Impedance:** 1 megohm, shunted by 30 pF.

Horizontal Amplifier

Sensitivity: 500 mV/cm or better. **Response:** DC to 250 kHz. **Input Impedance:** 1 megohm, shunted by 40 pF.

Sweep System

Type: Recurrent. **Sync:** Internal, negative.

Size: 5¼x7¾x11¼". For 117/234 VAC, 50-60 Hz. With leads.

JOURNAL READERS...

FROM FACTORY

B&K 'Starter's Bench'

MODEL 2050 RF SIGNAL GENERATOR

A versatile, easily portable, accurate signal generator. Covers 100 kHz to 30 MHz in 6 fundamental bands with 1% accuracy. Three outputs: RF, modulated RF (400 Hz) and externally modulated RF. 100% solid state, zener-regulated power supply. $7\frac{1}{2} \times 6\frac{1}{8} \times 9\frac{3}{4}$ ". For 117/234 VAC, 50-60 Hz. 3-wire line cord. **NET EACH: \$107.00**



MODEL 3050 AUDIO GENERATOR

Highly versatile sine/square wave generator, based on the Wien Bridge oscillator circuit. Covers 20 Hz to 200 kHz in 4 decades (sine and square waves). Accuracy, $\pm(3\% + 2\text{Hz})$. Features very high stability, even with line voltage variations. 10 V RMS output, 0-40 dB attenuation. Rise and fall times, 500 nano-seconds or less. Each selector position uses entire scale. Ideal for phase and time measurements, as well as a low-distortion source for AF measurements. For 117 VAC, 50-60 Hz. $6 \times 7\frac{3}{4} \times 9\frac{5}{8}$ ".

NET EACH: \$133.00



MODEL 277 MULTIMETER

Solid state electronic multimeter features high- and low-power ohms. Low-power ohms are indispensable for checking resistances in semiconductor or IC circuits. With the high-power ranges, you can cause the transistor to conduct and then reverse the leads to determine the front-to-back ratio. Reads DCV from 0.1 V to 1 KV; ACV, same; DC current, from 1 microamp to 1 amp. Has 7 low- and 7 high-power resistance ranges. Also reads dB. Size, $5\frac{13}{16} \times 7\frac{1}{4} \times 3\frac{5}{8}$ ". Complete with PR-21 probe; less batteries. Requires one 1.5V "D" cell and one 9 V NEDA 1604 cell.

NET EACH: \$102.00



MODEL HV-40 HIGH-VOLTAGE PROBE TESTER

Measures up to 30,000 volts with 2% accuracy. Extremely lightweight for ease in handling, yet very rugged. Anti-static treated housing. Knife-edge pointer and large numbers for ease of reading. Has built-in overload capability. 1.75" probe tip makes it easy to reach under tube corona cap.

NET EACH: \$35.00



Here's a "Reel" Deal... ...and a "Hot" Deal!

(a \$37.95 Value) Only \$15.40 each (a \$39.70 Value)
(POSTAGE PAID)

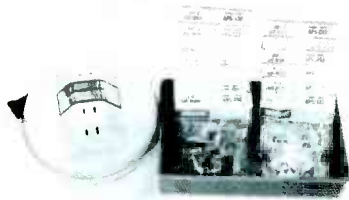

THE REEL DEAL #21AC

Here's what the "reel" deal includes:

- **65 Orange Drop Capacitors**

Best of the dipped tubulars and a must for applications where only an exact replacement will fit. "Orange Drops" are the perfect replacements for dipped capacitors now used by makers of the leading television receivers.

- **130 Kwickette Soldering Aids**

Answer to a serviceman's prayers. Saves you hours and hours of work. Makes parts replacement a snap. Practically lets you do "in-circuit" component testing.

- **Handy Work Tray**

Use it for storage, for spare parts, for keeping track of odds and ends from jobs in progress. One end has a file card slot for easy identification.

- **Cordomatic Portable Extension Reel**

Contains 15 feet of 16-gauge, 10-amp cord. Hang it anywhere or set it on the floor, it's the modern safe way to end cord clutter. Built for lifetime use, the CORDOMATIC case has three outlets. Use it in your shop, at home, and on service calls.

Here's what the "hot" deal includes:

- **20 Transolytic electrolytic capacitors**

Utilize a special low-leakage current construction and meet the very special needs of transistorized circuits. Excellent resistance to high humidity because of plastic case with thermo-setting resin end-seals. Each unit stamped with rating and polarity.

- **25 Pacer Film Capacitors**

Feature metal end caps over extended foil sections. Assures best possible non-inductive capacitors. End caps also effective moisture barriers. Protected by epoxy coating—rugged and durable.

- **90 Kwickette Soldering**

An answer to a serviceman's prayer. These are the soldering aids that are saving technicians hours and hours of work. For quick parts replacement. Practically lets you do "in-circuit" component testing.

YOUR
CHOICE
ONLY
\$15.40

- **Kidde Pocket Butane Torch Kit**

Great for all kinds of soft soldering and even for hard soldering on small work. Its 3500 degree (F) pinpoint flame lets you get into tight places. Comes complete with torch, soldering iron attachment, solder, and five 1/2 hour butane chargers.

THE HOT DEAL #28AC



CONAR

DIVISION OF NATIONAL RADIO INSTITUTE
 3939 WISCONSIN AVENUE • WASHINGTON, D.C. 20016

CHECK ONE: Cash Order
 C.O.D. (20% deposit required)
 Select-A-Plan Order

CHECK ONE: New CONAR Account
 Add-on CONAR Account
 Re-open CONAR Account

PLEASE PRINT			Ship to another address? Give Directions here		
Name <small>NRI Student or Graduate No.</small>			Name		
Address			Address		
City	State	Zip Code	City	State	Zip Code
Moved since last order?					
Previous Address			City State		

1. NAME OF ITEM	2. STOCK #	3. HOW MANY?	4. PRICE EACH	5. TOTAL	WEIGHT

IMPORTANT

To speed handling, any correspondence should be on separate paper.

All prices are net F.O.B., Wash., D.C.

Please include postage for weight shown and insurance on Parcel Post orders.

Express Orders should not include shipping charges.

A 20% deposit is required on C.O.D. orders. SELECT-A-PLAN ORDERS: Please complete and sign reverse side.

Thank you for your order.

Prices in the CONAR catalog and Select-A-Plan time payment privileges apply only to residents of the United States and Canada.

6. Total Cash Price For Merchandise		
<small>(Do not remit for items shipped Express Collect)</small>		
7. Parcel Post and Insurance		
8. 10% Cash Down Payment and Parcel Post Costs Required on New CONAR Accounts		
9. Unpaid Balance of Cash Price <small>(Items 6 & 7 less item 8)</small>		
10. Sales Tax <small>(Washington, D.C. Residents Only)</small>		
11. Unpaid Balance <small>(Amount to be financed) (Item 9 plus item 10)</small>		
12. Finance Charge <small>(See schedule on back)</small>		
13. Total of Payments <small>(Item 11 plus item 12)</small>		
14. Deferred Payment Price <small>(Items 6, 10 and 12)</small>		

Please do not write in this space

RETAIL INSTALLMENT CONTRACT & SECURITY AGREEMENT

CONAR SELECT-A-PLAN

SELECT YOUR TERMS TO FIT YOUR BUDGET

CONAR FINANCIAL RATES:

STANDARD PLAN—The ANNUAL PERCENTAGE RATE is 17.75%

EXTENDED PLAN—The ANNUAL PERCENTAGE RATE is 15.50%

TO SPEED SHIPMENT

1. Complete other side of this sheet.
2. Use Select-A-Plan Schedule on the right to find your Finance Charge and your Monthly Payment.
3. Insert amount of down payment (at least 10% of total order) and other information in Payment Agreement below.
4. Sign Payment Agreement and fill in Credit Application.

IMPORTANT: When you have made three monthly payments, you can "add-on" purchases with no down payment. If you are under 21, please have the Payment Agreement and credit application filled out and signed by a person over 21. He can make the purchase for you and will be responsible for payment. If you have a CONAR account open or recently paid-in-full, just sign the Payment Agreement.

NOTICE TO THE BUYER: (1.) Do not sign this agreement before you read it or if it contains any blank space. (2.) You are entitled to a copy of this signed agreement. (3.) The Finance Charge will be waived if the unpaid balance is paid within 30 days. If paid within 60 days, the Finance Charge will be reduced by 2/3; if paid within 90 days, the Finance Charge will be reduced by 1/3. Accounts extending beyond 30 days will pay up to \$3 in Credit Service Charges before the above reductions are made.

SELECT-A-PLAN SCHEDULE					
PLEASE CHECK ONE <input type="checkbox"/> STANDARD PLAN <input type="checkbox"/> EXTENDED PLAN					
IF UNPAID BALANCE IS	STANDARD PLAN		EXTENDED PLAN		Monthly Payments
	Finan- Charge	Monthly Pay- ments	Finan- Charge	Monthly Pay- ments	
20.01- 25.00	1.05	3.50			
25.01- 30.00	1.50	4.00			
30.01- 35.00	2.05	4.50			
35.01- 40.00	2.65	4.75			
40.01- 50.00	3.00	5.00			
50.01- 60.00	4.15	5.50			
60.01- 70.00	5.50	6.00	6.40	8.00	5.00
70.01- 80.00	7.00	6.50	8.00	10.10	5.00
80.01- 90.00	8.00	7.75	10.10	12.60	5.25
90.01-100.00	9.00	8.75	12.60	14.80	5.50
100.01-110.00	10.00	9.75	14.80	16.20	6.00
110.01-120.00	11.00	10.75	16.20	17.60	6.50
120.01-130.00	12.00	11.75	17.60	19.40	7.00
130.01-140.00	13.00	12.75	19.40	21.50	7.50
140.01-150.00	14.00	13.75	21.50	23.20	8.00
150.01-160.00	15.00	14.75	23.20	24.80	8.50
160.01-170.00	16.00	15.75	24.80	26.20	9.00
170.01-180.00	17.00	16.75	26.20	27.90	10.00
180.01-200.00	18.00	17.00	27.90	29.80	11.00
200.01-220.00	20.00	18.50	29.80	32.40	12.00
220.01-240.00	22.00	20.00	32.40	35.20	13.00
240.01-260.00	24.00	22.00	35.20	38.20	14.50
260.01-280.00	26.00	24.00	38.20	41.20	15.50
280.01-300.00	30.00	24.50	41.20	44.20	17.00
300.01-320.00	32.00	25.50	44.20	47.80	18.00
320.01-340.00	35.00	27.00	47.80	52.40	18.50
340.01-370.00	38.00	28.00	52.40	57.20	20.00
370.01-400.00	42.00	29.50	57.20	62.20	21.00
400.01-430.00	46.00	31.50	62.20	69.00	22.00
430.01-460.00	49.50	34.00			

ON ORDERS OVER \$460.00 THE FINANCIAL CHARGE ON THE EXTENDED PLAN WILL BE 35% AND PAYMENTS WILL BE IN PROPORTION TO AMOUNTS SHOWN ON ABOVE SCHEDULE

HOW TO DETERMINE THE NUMBER AND AMOUNT OF MONTHLY PAYMENTS TO REPAY THE "TOTAL OF PAYMENTS"

Use the Select-A-Plan Schedule to find out what your monthly payment is. Then divide your monthly payment into your "Total of Payments" to find out how many monthly payments you must make. The amount which is left over is your final payment. **FOR EXAMPLE,** if your unpaid balance is \$95, then your monthly payment is \$8.75 (using the Standard Plan). If your "Total of Payments" is \$104, then your monthly payment of \$8.75 divides into that number 11 times with \$7.75 left over. This means you make 11 payments of \$8.75 each, plus a final payment of \$7.75.

PAYMENT AGREEMENT

Enclosed is a down payment of \$ _____ on the merchandise I have listed on the reverse side. Beginning 30 days from date of shipment, I will pay CONAR \$ _____ each month for _____ months, plus a final monthly payment of \$ _____. Title to and right of possession of the merchandise shall remain in you until all payments have been made. If I do not make the payments as agreed, you may declare the entire balance immediately due and payable. In satisfaction of the balance, you may at your option, take back the merchandise, which I agree to return at your request. I understand that a 1% accounting charge will be added to my unpaid balance if my payments become 60 days or more in arrears. I agree that the above conditions shall apply to any add-on purchases to my Select-A-Plan account. The statements below are true and are made for the purpose of receiving credit.

DATE _____ BUYER SIGN HERE _____

IT'S AS EASY AS A - B - C TO OPEN A CONAR ACCOUNT

PLEASE ALLOW ADEQUATE TIME FOR NORMAL ROUTINE CREDIT CHECK. ONCE YOUR CREDIT IS ESTABLISHED, ONLY YOUR SIGNATURE IS NEEDED TO ADD ON PURCHASES

		WHERE DO YOU LIVE?				Age
	PRINT FULL NAME		CITY	STATE	ZIP CODE	
A →	HOME ADDRESS					
	HOME PHONE					
	() OWN HOME () RENT	HOW LONG AT THIS ADDRESS				
	WIFE'S NAME	RENT OR MORTGAGE PAYMENTS \$ _____				PER. MO.
		MARITAL STATUS () MARRIED () SINGLE				
		NUMBER OF DEPENDENT CHILDREN _____				
	PREVIOUS ADDRESS	HOW LONG?				
WHERE DO YOU WORK?						
	YOUR EMPLOYER	POSITION				MONTHLY INCOME \$ _____
B →	EMPLOYER'S ADDRESS	HOW MANY YEARS ON PRESENT JOB?				
		Street	City	State		
	PREVIOUS EMPLOYER	HOW LONG?				
		Name	Address			
	WIFE'S EMPLOYER	MONTHLY INCOME \$ _____				
		Name	Address			
WHERE DO YOU TRADE?						
C →	BANK ACCOUNT WITH	() CHECKING				
		Street	City	State	() SAVINGS	
	CREDIT ACCOUNT WITH	() LOAN				
		Street	City	State		
	CREDIT ACCOUNT WITH	TOTAL OF ALL MONTHLY PAYMENTS INCLUDING CAR \$ _____				
		Street	City	State		

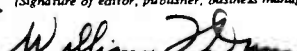
U. S. POSTAL SERVICE STATEMENT OF OWNERSHIP, MANAGEMENT AND CIRCULATION <i>(Act of August 12, 1970. Section 3685. Title 39. United States Code)</i>		SEE INSTRUCTIONS ON PAGE 2 (REVERSE)
1. TITLE OF PUBLICATION NRI Journal		2. DATE OF FILING October 1, 1974
3. FREQUENCY OF ISSUE Bimonthly		
4. LOCATION OF KNOWN OFFICE OF PUBLICATION <i>(Street, city, county, state, ZIP code) (Not printers)</i> 3939 Wisconsin Avenue, Washington, D.C. 20016		
5. LOCATION OF THE HEADQUARTERS OR GENERAL BUSINESS OFFICES OF THE PUBLISHERS <i>(Not printers)</i> National Radio Institute, 3939 Wisconsin Avenue, Washington, D.C. 20016		
6. NAMES AND ADDRESSES OF PUBLISHER, EDITOR, AND MANAGING EDITOR		
PUBLISHER <i>(Name and address)</i> William F. Dunn, 8802 Fox Hills Trail, Potomac, Maryland 20854		
EDITOR <i>(Name and address)</i> Same		
MANAGER EDITOR <i>(Name and address)</i> Thomas H. Beadling, 1021 Arlington Boulevard, Arlington, Virginia 22209		
7. OWNER <i>(If owned by a corporation, its name and address must be stated and also immediately thereunder the names and addresses of stockholders owning or holding 1 percent or more of total amount of stock. If not owned by a corporation, the names and addresses of the individual owners must be given. If owned by a partnership or other unincorporated firm, its name and address, as well as that of each individual must be given.)</i>		
NAME McGraw-Hill, Inc.	ADDRESS 1221 Avenue of the Americas, New York, N.Y. 10020	
8. KNOWN BONDHOLDERS, MORTGAGEES, AND OTHER SECURITY HOLDERS OWNING OR HOLDING 1 PERCENT OR MORE OF TOTAL AMOUNT OF BONDS, MORTGAGES OR OTHER SECURITIES <i>(If there are none, so state)</i>		
NAME	ADDRESS	
9. FOR OPTIONAL COMPLETION BY PUBLISHERS MAILING AT THE REGULAR RATES (Section 132.121, Postal Service Manual)		
39 U. S. C. 3626 provides in pertinent part: "No person who would have been entitled to mail matter under former section 4359 of this title shall mail such matter at the rates provided under this subsection unless he files annually with the Postal Service a written request for permission to mail matter at such rates." In accordance with the provisions of this statute, I hereby request permission to mail the publication named in item 1 at the reduced postage rates presently authorized by 39 U. S. C. 3626. (Signature and title of editor, publisher, business manager, or owner)		
10. FOR COMPLETION BY NONPROFIT ORGANIZATIONS AUTHORIZED TO MAIL AT SPECIAL RATES (Section 132.122, Postal Manual) <i>(Check one)</i>		
The purpose, function, and nonprofit status of this organization and the exempt status for Federal income tax purposes		<input type="checkbox"/> Have not changed during preceding 12 months <input type="checkbox"/> Have changed during preceding 12 months
<i>(If changed, publisher must submit explanation of change with this statement.)</i>		
11. EXTENT AND NATURE OF CIRCULATION	AVERAGE NO. COPIES EACH ISSUE DURING PRECEDING 12 MONTHS	ACTUAL NUMBER OF COPIES OF SINGLE ISSUE PUBLISHED NEAREST TO FILING DATE
A. TOTAL NO. COPIES PRINTED <i>(Net Press Run)</i>	44,140	44,200
B. PAID CIRCULATION		
1. SALES THROUGH DEALERS AND CARRIERS, STREET VENDORS AND COUNTER SALES	None	None
2. MAIL SUBSCRIPTIONS	41,908	41,227
C. TOTAL PAID CIRCULATION	41,908	41,227
D. FREE DISTRIBUTION BY MAIL, CARRIER OR OTHER MEANS		
1. SAMPLES, COMPLIMENTARY, AND OTHER FREE COPIES	320	320
2. COPIES DISTRIBUTED TO NEWS AGENTS, BUT NOT SOLD	None	None
E. TOTAL DISTRIBUTION <i>(Sum of C and D)</i>	42,228	41,547
F. OFFICE USE, LEFT-OVER, UNACCOUNTED, SPOILED AFTER PRINTING	1,912	2,653
G. TOTAL <i>(Sum of E & F - should equal net press run shown in A)</i>	44,140	44,200
(Signature of editor, publisher, business manager, or owner)		
		
I certify that the statements made by me above are correct and complete.		

Order Now from CONAR

CLOSE-OUT ON
ROLL-AROUND TABLE

LIMITED
QUANTITIES

Designed originally for the Conar Custom 70 and 75 television receivers. Use it as a television table, flower cart, or adapt it for use as a stereo or snack table. Originally priced at \$7.97.



Stock No.126TO

NOW ONLY \$4.00

Plus \$1.00 to cover the cost of shipping and handling

NRI JOURNAL
3939 Wisconsin Avenue
Washington, D.C. 20016

MR WILLARD F VELLINE 25923 G
1322 S 14 1-2 ST
FARGO ND 58102

Second-class
postage paid
at Washington, D.C.
and additional entry