

POPULAR COMMUNICATIONS

APRIL 1991 \$2.95
\$3.95 CANADA

Secrets Of Cellular Car Phones!

Also in this issue:

- Scanning Desert Storm
- Selected English Language Broadcasts:
Spring, 1991
- Proper Use Of Your Receiver
- Scanning The Satellites
- Pull Out Section: World Band Tuning Tips



**Plus: Nostalgia, CB, Ham Radio, Pirates,
& More!**



YOU EXPECT THE WORLD FROM ICOM RECEIVERS

ICOM's IC-R71A and IC-R7000 are the professional's choice for receiving international broadcasts, aircraft, marine, business, emergency services, television, and government bands. These people demand the finest in communications and so do you. ICOM puts the world at your fingertips with the IC-R7000 25-2000MHz* and IC-R71A 0.1-30MHz commercial quality scanning receivers.

Incomparable Frequency Control. Both the IC-R71A and IC-R7000 feature **direct frequency access** via their front keypad, main tuning dial, optional infrared remote control and/or computer interface adapter. **Incredible Flexibility!**

Full Coverage, Maximum Performance. The superb IC-R71A is your key to world-wide SSB, CW, RTTY, AM and FM (optional) communications plus foreign broadcasts in the 100kHz to 30MHz range. It features IF Notch, low noise mixer circuits and a 100db dynamic range. The pacesetter **IC-R7000** receives today's hot areas of interest, including aircraft, marine, public services, amateur, and satellite transmissions in the 25MHz

to 2000MHz* range. It includes **all mode operation** low noise circuits plus outstanding sensitivity and selectivity. The IC-R71A/R7000 combination is your window to the world!



The IC-R71A is a shortwave listener's delight. Its **32 tunable memories** store frequency and mode information, and they are single-button reprogrammable **independent of VFO A or VFO B's operations!** Dual width, an adjustable noise blanker, panel selectable RF preamp, and selectable AGC combined with **four scan modes** and all-mode squelch further enhance the IC-R71A's HF reception!

The IC-R7000 features 99 tunable memories and **six scanning modes**. It even scans a band and loads memories 80 to 99 with active frequencies without

operator assistance! Additional features include selectable scan speed pause delays, wide/narrow FM reception and high frequency stability.

Options. IC-R7000: RC-12 remote control, EX-310 voice synthesizer, CK-70 DC adapter, MB-12 mobile bracket. IC-R71A: RC-11 remote control, EX-310 voice synthesizer, CK-70 DC adapter, MB-12 mobile bracket, FL-32A 500Hz, FL-63A 250Hz and FL-44A filters.

See these quality ICOM receivers at your local authorized ICOM dealer today.

*Specifications of the IC-R7000 guaranteed from 25-1000MHz and 1260-1300MHz. No coverage from 1000-1025MHz.

ICOM America, Inc. 2380-116th Ave. N.E., Bellevue, WA 98004
Customer Service Hotline (206) 454-7619
 3150 Premier Drive, Suite 126, Irving, TX 75063 /
 1777 Phoenix Parkway, Suite 201, Atlanta, GA 30349
 ICOM CANADA, A Division of ICOM America, Inc.,
 3071 - #5 Road, Unit 9, Richmond, B.C. V6X 2T4 Canada

All stated specifications are subject to change without notice or obligation. All ICOM radios significantly exceed FCC regulations limiting spurious emissions. Receivers 59-89



ICOM

First in Communications



The ICOM EXPERTS

Minutes From
Washington, D.C.

CLASSIC



R71A .1-30 MHz

- World Class HF Receiver
- All Mode AM, CW, SSB, RTTY, FM (Opt)
- Keyboard And Memory Frequency Entry
- 32 Programmable Memory Channels
- Optional Filters, Voice, 12VDC, Computer Input
- Many EEB Options Listed In Our 1990 Catalog
- 117/220/234 VAC 13.8 VDC (Opt)
- 11.25W x 4.44 x 10.9D (Inch) 16.5 Lbs

List \$999

EEB Discount Price \$849.95 + UPS

Get The Details From
Our FREE 1990 Catalog.

CLASSIC



R7000 25-2000 MHz

- VHF/UHF Classic Nothing Like It Under \$4000
- Triple Conversion Eliminates Images
- Tuning Steps .1, 1.5, 10, 12.5, 25 MHz Increments
- 99 Programmable Memory Channels
- Sensitivity Better Than .5µV (12dB SINAD) FMN
- Multimode AM, FM, FMN, FMW, CW/SSB
- Many EEB Options Listed In Our 1990 Catalog
- 117/220/234VAC 13.8VDC (Opt)
- 11.25W x 4.4H x 10.9D (Inch) 17.5 Lbs

List \$1199.00

EEB Discount Price 1019.00 + UPS

CLASSIC



R9000 .1-2000 MHz

- Never Has So Much Been Offered In One Receiver
- Covers Everything VLF (100 kHz) To Super UHF 2 GHz
- Multimode AM, FM, FMN, FMW, CW, SSB, RTTY
- 1000 Programmable Memory Channels
- DDS (Direct Digital Synthesizer) Tuning
- CRT, Spectrum Analyzer, Multi Screen Readout
- Power 100-120VAC 220-240 12VDC (Opt)
- EEB Optional Power Supply And Filters
- 16.7W x 5.9H x 14.4D (Inch) 44.1 Lbs

List \$5495.00

Call EEB Discount Price \$4795.00 + UPS

**FREE DETAIL LITERATURE ON ALL ICOM PRODUCTS
CALL 1-800-999-9877**

CLASSIC



ICF2010 RECOGNIZED BY THE EXPERTS AS THE WORLDS BEST PORTABLE RECEIVER, "IT EVEN RIVALS SOME TABLE MODELS".

- AM/CW/LSB/USB .15-30MHz
- FM Wide 76-108MHz
- Air Band AM 116-136MHz
- 32 Memories-Keyboard Entry
- Synchronous Detection
- Separate Multi Function Clock
- 6.2 x 11.4 x 2 Inches 3.8 Pounds
- Power AC120V Adaptor Incl. Option 12VDC DCC127A 3 "D" Cell, 2 "AA" Not Included
- Free EEB RS-1 Radio Stand With Order

List \$429.95 **EEB \$349.95 + \$6 UPS**

CATALOG



CATALOG

- Full Line SWL Receivers
- Many SWL Antennas
- Scanners & Accessories
- Books, Books & More Books
- Converters, Filters
- Clocks, Speakers & More
- Ask To Be Put On Our Mailing List For Future Publications

FREE Call Or Mail In For Your FREE Copy

NEW



SONY ICF SW 7600

- SW All Bands .1-30 MHz
- FM Stereo With Headphones (Incl)
- 10 Memories & Clock Timer Alarm
- CW SSB (USB, LSB) AM FM
- Keyboard Frequency Entry
- Complete System Including Ext Ant, Headset, Book, AC Adapter
- New Replacement For ICF-2003
- Free EEB RS-1 Radio Stand With Order

List \$259.95 **EEB \$219.95 + UPS**

EEB ELECTRONIC EQUIPMENT BANK
323 MILL STREET, N.E.
VIENNA, VA 22180

ORDERS: 800-368-3270

LOCAL TECH: 703-938-3350

FAX: 703-938-6911

- PRICES SUBJECT TO CHANGE
- PRICES DO NOT INCLUDE FREIGHT
- SORRY, NO CODs
- RETURNS SUBJECT TO 15% RESTOCK FEE

POPULAR COMMUNICATIONS

APRIL 1991

VOLUME 9, NUMBER 8



9

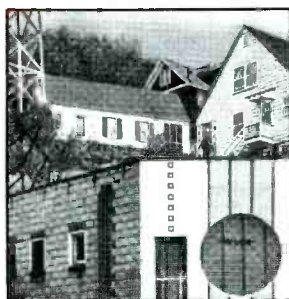

15



16

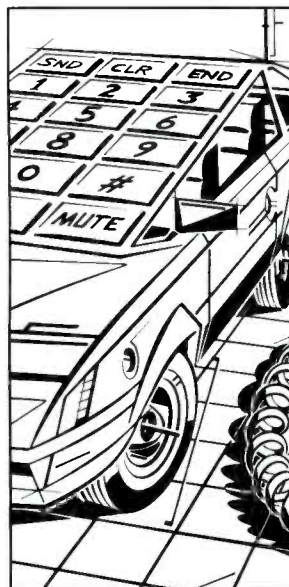

29

FEATURES

- Secrets Of Cellular Car Phones** 9
All The Good Stuff They'll Never Tell You About Buying And Using Car Phones. *By Tom Kneitel, K2AES*
- The History Of Communications** 15
Our April Issue Special, With Apologies To Miss Brannigan. *By Del Soady*
- Radio's Golden Era** 16
Let's Roll Back The Clock And See How It Was! *By Alice Brannigan*
- Books You'll Like** 22
Everything About Electronics, Computer Crimes, and Bill Cheek. *By R.L. Slattery*
- Selected English Language Broadcasts - Spring 1991** 24
By Gerry Dexter
- Zeroing In On Worldwide Scanner Skip** 28
Mysterious Military "Lists" Stations, Desert Storm, Even Pirates—Hear 'Em On Your Scanner. *By Chuck Robertson*

COLUMNS

- Satellite View 32
Scanning VHF/UHF 36
You Should Know 38
Broadcast DXing 42
Emergency 46
How I Got Started 48
CB Scene 50
Pirates Den 53
Communications Confidential 54
Ham Column 59
Washington Pulse 60
Listening Post 62
Clandestine Communique 67
RTTY 68
Telephones Enroute 74

DEPARTMENTS

- Beaming In 4
Mailbag 6
Worldband Tuning Tips 40
New Products 49
Communications Shop 77

This month's cover: As natural on the job-site as it is in a luxury car, the cellular phone has become a necessity to hundreds of thousands of people. *Photo by Larry Mulvehill.*

EDITORIAL STAFF

Tom Kneitel, K2AES/KNY2AB, Editor
Jeanine M. O'Connor, Associate Editor

CONTRIBUTING EDITORS

Gerry L. Dexter, Shortwave Broadcast
Robert Margolis, RTTY Monitoring
Gordon West, WB6NOA, Emergency
Don Schimmel, Utility Communications
Edward Teach, Alternative Radio
Harold A. Ort, Jr., Military Consultant
Janice Lee, Radar Detectors
Chuck Gysi, N2DUP, Scanners
Roger Sterckx, AM/FM Broadcasts
Harry Helms, AA6FW, Thoughts and Ideas
Donald Dickerson, N9CUE, Satellites
Kirk Kleinschmidt, NT0Z, Amateur Radio

BUSINESS STAFF

Richard A. Ross, K2MGA, Publisher
Donald R. Allen, N9ALK, Advertising Mgr.
Emily Kreutz, Sales Assistant
Dorothy Kehrwieler, General Manager
Frank V. Fuzia, Controller
Catherine Ross, Circulation Director
Melissa Kehrwieler, Data Processing
Carol Minervini, Data Processing
Karen Nauth, Customer Service

PRODUCTION STAFF

Elizabeth Ryan, Art Director
Barbara Terzo, Artist
Dorothy Kehrwieler, Production Manager
Emily Kreutz, Production
Pat Le Blanc, Phototypographer
Florence V. Martin, Phototypographer
Linda Romanello, Typesetting
Hal Keith, Technical Illustrator
Larry Mulvehill, WB2ZPI, Photographer

A publication of

 CQ Communications, Inc.
76 North Broadway
Hicksville, NY 11801-2953 USA.

Offices: 76 North Broadway, Hicksville, NY 11801. Telephone 516 681-2922. FAX (516) 681-2926. Popular Communications (ISSN 0733-3315) is published monthly by CQ Communications, Inc. Second class postage paid at Hicksville, NY and additional offices. Subscription prices: Domestic—one year \$19.95, two years \$38.00, three years \$57.00. Canada/Mexico—one year \$22.00, two years \$42.00, three years \$63.00. Foreign—one year \$24.00, two years \$46.00, three years \$69.00. Foreign Air Mail—one year \$77.00, two years \$152.00, three years \$228.00.

U.S. Government Agencies: Subscriptions to Popular Communications are available to agencies of the United States government, including military services, only on a cash with order basis. Requests for quotations, bids, contracts, etc. will be refused and will not be returned or processed.

Entire contents copyright ©1991 by CQ Communications, Inc. Popular Communications assumes no responsibility for unsolicited manuscripts, photographs, or drawings. Allow six weeks for change of address or delivery of first issue. Printed in the United States of America.

Postmaster: Please send change of address to Popular Communications, 76 North Broadway, Hicksville, NY 11801.

UNIVERSAL SHORTWAVE

Monitor More With Advanced Equipment From Universal!

COMMUNICATIONS RECEIVERS

□ Japan Radio NRD-525



For the communications connoisseur. Covers .1-34 MHz. Incredible performance and features. In stock. \$1129.95 (+\$12 UPS)

□ Kenwood R-5000

A powerful receiver for the serious DXer. An exceptional value. \$849.95 (+\$11 UPS)

□ Kenwood R-2000

Many features: mems., scan, sweep, FM mode, 24 hr. clock etc. \$649.95 (+\$10 UPS)

□ Icom R-71A

A well-respected time-tested performer. Notch, 2 VFOs, keypad. *On special ... CALL*

□ Yaesu FRG-8800

Beautiful LCD display, keypad, memories and more. \$689.95 (+\$9 UPS)

PORTABLE RECEIVERS

□ Sangean ATS-803A



Keypad, memories, BFO, clock, RF gain, etc. A strong performer and unbeatable value. *CALL FOR PRICE*

□ Sony ICF-2010

Super high performance and features. VHF air too. \$359.95 (+\$5 UPS)

□ Magnavox AE3805BK

A digital radio at an analog price. Covers 3.2-7.3 & 9.5-21.7MHz \$119.95 (+\$4 UPS)

□ Grundig Satellit 500

Hi-tech with beautiful fidelity and style. Synchronous tuning. \$499.00 (+\$5 UPS)

Note: Radios listed above are all LW-MW-SW-FM digital. Contact us for other models

SPECIAL RECEIVERS

□ Icom R-9000



Solid all-mode coverage from .1 to 1999.8 MHz. Multi-function CRT with spectrum analyzer. The ultimate receiver! *CALL FOR PRICE.*

SHORTWAVE ANTENNAS

□ Alpha Delta DX-SWL Sloper

MW +120-13 meter bands (60') \$67.95+\$4

□ Alpha Delta DX-SWL Sloper-Short

90-13 meter bands (40') \$57.95+\$4

□ Eavesdropper Specify twin lead or coax type

9 SW bands (60-10 meters) \$74.95+\$4

□ McKay Dymek DA100D Active Antenna

The Cadillac of active antennas! .. \$179.95+\$4

□ Sony AN-1 Active Antenna

For portables, covers .15-30 MHz. \$84.95+\$4

Note: Many more antennas available. See catalog.

MULTI-MODE CONVERTERS

□ Universal M-7000



The Universal M-7000 will permit you to intercept and decode Morse code, various forms of RTTY, FDM and FAX. Simple connections to your receiver and video monitor will enable you to monitor with the most sophisticated surveillance decoder available. No computer is required. See the world of shortwave excitement you have been missing. Requires 115/230 AC 50/60 Hz. With video fax and real time clock only \$1159.00 *Please write for full details.*

- ◆ Morse Code (CW)
- ◆ Regular Baudot RTTY
- ◆ Bit Inverted & Var. Baudot
- ◆ ASCII Low & High Speed
- ◆ Sitor Mode A & B
- ◆ ARQ-M2 & M4 (TDM)
- ◆ ARQ-E and ARQ-E3
- ◆ FEC-A and FEC-S
- ◆ SWED-ARQ and ARQ-S
- ◆ VFT Modes (FDM)
- ◆ Russian 3rd Shift Cyrillic
- ◆ Facsimile (FAX) AM/FM
- ◆ Packet 300 & 1200 AX.25
- ◆ Remote Terminal
- ◆ Literal & Databit Modes
- ◆ Variable & Standard Shift
- ◆ Automatic Tuning
- ◆ Diversity Reception

MULTI-MODE CONVERTERS

□ Universal M-900

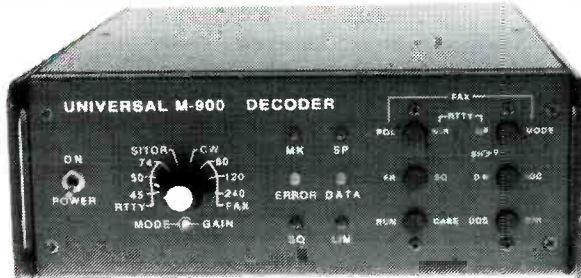

Here is a compact, easy to use decoder that copies all the most important shortwave transmission modes. The M-900 covers Morse code for monitoring hams, ships and coastal stations. Baudot RTTY is included for decoding weather and international press broadcasts. Both Sitor A and Sitor B are supported for monitoring the extensive maritime and diplomatic traffic. Facsimile (to the printer only) lets you receive maps and pictures from around the world. Requires 12 VDC @ .8A Text output to video monitor. \$499.95 (+\$8)

- ◆ Morse Code (CW)
- ◆ Regular Baudot RTTY
- ◆ Sitor Mode A (ARQ)
- ◆ Sitor Mode B (FEC)
- ◆ Facsimile (FAX) FM
- ◆ Variable & Standard Shift

M-900 System Components
A complete M-900 system would require:

- Universal M-900
- 12 VDC Power Supply
- Your SW Receiver
- Video Monitor
- Parallel Printer
- Cables for above

Please write to Universal for full information on the M-900 and the above optional items. Full system prices are available.

COMMUNICATIONS BOOKS

□ Passport To Worldband Radio 1991 Ed.

By L. Magne. Graphic presentation of all SWBC stations. Equipment reviews too. \$16.95

□ Shortwave Receivers Past & Present

By F. Osterman. Your guide to 200 receivers with new-used value, specs, features. \$6.95

□ Aeronautical Communications Handbook

By R. Evans. A mammoth book on all aspects of shortwave aero listening. 266 pages. ... \$19.95

□ Complete SWL's Handbook Third Edition

By Bennett, Helms, Hardy. Nearly 300 pages on all aspects of SWL'ing. \$16.95

□ Guide To Utility Stations 1991 9th Edition

By J. Klingentuss. The definitive guide to utility stations- CW, SSB, FAX and RTTY..... \$33.95

□ Guide To Facsimile Stations

By J. Klingentuss. The complete guide to FAX with freqs., schedules and addresses... \$24.95

□ World Radio TV Handbook 1991 Edition

All SWBC stations by country with schedules, addresses, power, etc. Reviews too. ... \$19.95

✓ *Please add \$1 per title for shipping.*

COMMUNICATIONS CATALOG

Universal now offers a new combined communications catalog covering shortwave, amateur and scanner equipment. There is also an unbeatable selection of antennas, books, parts and accessories. This huge 92 page (8½" by 11") publication covers everything for the radio enthusiast. With prices, photos and full descriptions.

Available FREE by fourth class mail or \$1.00 by first class mail.

STORE HOURS

Monday - Friday 10:00-5:30

Except Thursday 10:00-8:00

Saturday 10:00-3:00

- We ship worldwide
- in business since 1942!
- Visa, MC, Discover
- Prices & specs. are subject to change.
- Used equip. list available

Universal Radio

1280 Aida Drive Dept. PC

Reynoldsburg, Ohio 43068 U.S.A.

Ohio: 614 866-4267 Toll Free: 800 431-3939

Something To Think About

Springtime carries with it the tradition of renewal, rejuvenation, and rebirth. This is ancient and universal within mankind, dating back even to civilizations that existed prior to our own culture. When you see what takes place in nature every spring, it's easy to realize how this symbolism so readily fell into place, and has continued through the ages.

Things of nature are self-renewing, and are so based upon their own internal clocks. Unless external forces affect the environment of life forms, their renewal cycles could continue unabated for eons. Science has long been attempting to interrupt the renewal potentials of various harmful things, like certain viruses, bacteria, and plant/insect pests. And through accident, carelessness, indifference, malice, stupidity, avarice, and other causes, civilization in general has managed to do in a number of other things of nature that were beneficial, benign, or too weak, inefficient, or unsuspecting to defend themselves.

Things that mankind has created, though, usually aren't self-renewing. Without continuing and deliberate effort for renewal, they just slowly and insidiously taper off into history, then people wonder what happened. If they existed only briefly, we call them fads. If they lasted a long time but then start to falter, we come to feel that they outlived their usefulness, or were replaced by something better. At times they just sputter out because "someone else" was thought to be taking care of the renewal process, and it turned out that insufficient effort was put in by all concerned.

The present springtime budding of the trees, and the first crocus flowers, are as good a reminder as any that our communications hobby is also in need of renewal. The difference is that the renewal of the hobby isn't going to take place without a lot more active participation from within to make it happen. The stats aren't good. Technologically inclined youngsters, who used to gravitate into SWL'ing and hamming in hordes, aren't doing so in big numbers any longer. For decades, our eager postulants came knocking at the hobby's door on their own because SWL'ing and hamming were about the only games in town. Compared to the old days, today it's just a trickle.

Fact is, now their interests have been diverted—headed off at the pass—siphoned off by many glitzy attractions, including personal computers, BBS's, cellulators, video games, VCR's, CD's, music videos and high concept TV programs slickly designed to

hold their attention. These things are backed by massive big bucks promotional campaigns that relentlessly sell their tantalizing diversions in the most seductive ways imaginable.

It's no wonder Justin is no longer figuring out how much wire he needs to string out the window in order to hear Ankara or Caracas. Geography isn't taught any longer, so he hasn't even heard of those places. In a world of satellites and Star Wars, he isn't naturally inclined to see much point in being very concerned whether the letter "S" is the one with 3-dots, or 4-dots. Someone is going to have to try hard to catch his attention, then point out these miracles.

If there is to be any renewal of the communications hobby, then Justin, Jared, Jason, and Jessie, are going to have to be actively recruited, enticed, invited, then taken by the hand and gently led into the hobby. And if you feel that you have personally gotten something out of this hobby, then I suggest that at the very least you give back to this hobby the minimum of one convert dedicated towards its future. Sure, if you can recruit more than one conscript, or a dozen, or a dozen dozen, that's great. But the hobby will settle for only one. If every active SWL or ham could bring a single new member into the hobby, it can rejuvenate and continue. The present hard-core nucleus of our hobby consists mostly of old timers.

People within the hobby should encourage their children to share it with them. It may not spark any interest, but if any is shown, then it can be slowly nurtured. My own kids never got bitten by the radio bug, but I have been lucky enough to have been able to get the children of some of my friends started in radio.

Most of us occasionally turn up an old receiver or scanner, found in the back of a closet, or purchased used at a swap meet or hamfest for a couple of dollars. With a little instruction and follow-up, these can be turned into wonderful intros to the hobby for beginners.

No need to limit new recruits to youngsters. There are many adults who would enjoy this hobby if someone would only take the time to demonstrate a shortwave receiver or scanner in action. I'm thinking in particular of people with plenty of time on their hands and nothing much to keep them occupied. Some folks who retire from busy careers take to this hobby beautifully. Or, perhaps you have a friend, relative, or neighbor, who is confined to their bed or

home, or otherwise spends many lonely hours with nothing very stimulating to do. This will do it!

The thing is that this is one of those interests that is best introduced to others by personal contact, enthusiasm, and a demonstration of the hardware in action. It doesn't need much more than that, but it does need at least that much. Forget that you are proselytizing for your own motives, think of it as opening up a new, magical, and wondrous world of communications to those who will grow to find it immensely rewarding and challenging. Whether you do this on a one-on-one basis, or by demonstrating your hobby in front of a classroom, or at a retirement home, it makes no difference.

Some members of the hobby contribute significantly to its revitalization by running school radio clubs, giving radio or code classes, or by serving as volunteer examiners for ham licenses. These are the "someone else's" most of us think of as being the ones passing the flame from one generation to another. Yes, they are the vital framework for getting the job done, but it's going to take much more than the efforts of these relatively few dedicated souls in order for the hobby to continue on and not slowly sputter out with the passing years.

Maybe you've taken your share of what this hobby has to offer, but feel that it can now be left to die off if it can no longer hold its own unaided against the razzle-dazzle of PC's, M-TV, *Nintendo*, and other technologies. Pardon me for not feeling that way. I've enjoyed the hobby for forty five years, from the time I was a young kid. It's given me more enjoyment than I could have ever hoped for when I started out. But, now it needs help. It needs an influx of new personalities, new ideas, new methods, new talents, new experts, new viewpoints, and new shoulders to carry it boldly into the future as the first class avocation it is.

What it needs is you. Mostly, you going out among the masses carrying a big hook to bring warm bodies into our beloved hobby and flesh out its ranks. This is the only way it can renew itself. I could be wrong, but I think you owe it to the hobby to do your share towards its continuing existence.

Maybe you're too busy. Or you think you don't need to bring in a new member yourself because, after all, someone else will surely bring in two new members. That's the rationale that will end this hobby. I don't want it on my karma. Do you?

Will the last one in the hobby please turn out the lights, and shut off the radio. ■

MAILBAG

LETTERS TO THE EDITOR

Each month we select representative reader letters for our Mailbag column. We reserve the right to condense lengthy letters for space reasons. All letters submitted for consideration must be signed and show a return address. Upon request, we will withhold sender's name should the letter be used in Mailbag. Address letters to Tom Kneitel, Editor, Popular Communications Magazine, 76 North Broadway, Hicksville, NY 11801.

Aye, Aye For The Private Eye Story

Here's a compliment to POP'COMM on the December feature entitled, *Scanning The Private Detectives*. I found it to be of special interest as I have been employed in the private protection services field for more than fifteen years. Certainly there are many items of interest over the airwaves on a daily basis.

This article briefly touched on some of the other potentially interesting facets of the security field, such as hospitals, office com-

plexes, industrial plants, etc. Having been responsible for these types of security operations at some point in my career, I can attest to the importance of radio communications in routine and extraordinary situations. For instance, the department which I currently direct is responsible for safety and security operations for a major insurance company here in Milwaukee. Our facilities are located in the heart of the downtown area, adjacent to a multitude of other businesses, including shopping malls, hotels, universities, etc. In addition to our two-way system (using Standard, Kenwood, and GE handhelds, along with a Standard repeater), we utilize several VHF/UHF scanners. These are programmed for the local police and fire frequencies, as well as various government agencies. We also monitor frequencies used by other area private security departments. This use has proven to be of great benefit, and truly keeps us informed as to happenings that could affect our employees or property. On occasion, we have assisted our corporate neighbors in apprehending shoplifters, "sneakthieves," auto theft suspects, etc. This not only assists fellow security professionals, but has fostered

a greater spirit of cooperation and neighborhood awareness.

I have been a regular reader of POP'COMM ever since discovering it, purely by accident, on a trip to a local bookstore. That was eight months ago and, thanks to your magazine, I have branched out from scanning to an interest in shortwave listening.

Craig Martin,
Milwaukee, WI

Skippin' Around

I was inspired by Chuck Robertson's article *The World's Newsbreaking Events—On Your Scanner* (November, '90 issue). It made me fire up my trusty Bearcat 210 scanner and search around between 30 and 50 MHz for low band skip. Wow! I found lots of stations! I can't identify all of them, but I'm working on that. I found 32.74 MHz particularly interesting. Sounds like maybe New York, and that's pretty good for skipping to Texas and into my indoor antenna. I really enjoy your magazine.

Spencer G. Sholly, KA7NQM,
Registered Monitor KUS0CJ,
Killeen, TX

Shop AES® for Shortwave • Amateur Radio • Scanners

This month featuring the . . .

YAESU FRG-8800 Shortwave Receiver

Coverage: 150kHz to 30MHz and 118 to 174MHz with optional VHF converter. **Modes:** AM, SSB, CW and FM narrow and wide. **Features:** Multi-function fluorescent display; bargraph S-meter; VFO or keypad for digital frequency entry and programming; 12 tunable memories; programmable memory and band scan; dual 24-hour clocks; recording timer; computer control & 12VDC options. **Size:** 4.6" h x 13.1" w x 8.9" d, 13.4 lbs.

FRG-8800 ACCESSORIES

FRA-7700 • Indoor active antenna
FRT-7700 • Antenna tuner
FRV-8800 • 118-174MHz VHF converter
FIF-232C • Computer interface
DC-8800 • 12V DC kit
FM-W/8800 • FM-wideband kit

Call Toll Free for Low Sale Prices



Store Hours: Mon. thru Fri. 9-5:30pm ; Sat. 9-3 pm

Order Toll Free: 1-800-558-0411

FAX: (414) 358-3337

AMATEUR ELECTRONIC SUPPLY® Inc.

5710 W. Good Hope Road; Milwaukee, WI 53223 • Phone (414) 358-0333

AES® BRANCH STORES

WICKLIFFE, Ohio 44092
28940 Euclid Avenue
Phone (216) 585-7388
1-800-321-3594

ORLANDO, Fla. 32803
621 Commonwealth Ave.
Phone (407) 894-3238
1-800-327-1917

CLEARWATER, Fla. 34625
1898 Drew Street
Phone (813) 461-4267
No Toll Free Line

LAS VEGAS, Nev. 89106
1072 N. Rancho Drive
Phone (702) 647-3114
1-800-634-6227

Associate Store
CHICAGO, Illinois 60630
ERICKSON COMMUNICATIONS
5456 N. Milwaukee Avenue
Phone (312) 631-5181
1-800-621-5802

TRINITRON
Super fine pitch

POWER



PUT THE PC10 IN YOUR PC FOR MORE COUNTER POWER.



OPTOELECTRONICS does it again - phenomenal power, performance and price.

This is what sets our PC Based Universal Counter apart from any other counter available on the market today...

Model PC10 Universal Counter Timer Board for the PC. Introductory Price \$339.

The PC10 has on board 50 ohm RF input with amplifiers and prescalers to operate as a stand alone 1MHz to 2.4GHz RF counter. TTL level input signals can be connected directly to the miniature 25 pin D connector on the mounting bracket. For low frequency, high impedance inputs, the Model AP10H companion amplifier must be used.

Model AP10H Dual High Impedance Amplifier Head Unit (Not Shown). Introductory price \$299.

The AP10H is the companion head unit that supports all PC10 Universal Counter functions from 10Hz to 100MHz with 1 megohm inputs. Input attenuators, low pass filters and trigger levels are software selectable.

Options: TCXO 10 Precision Temperature Compensated Time Base \$195. ± 0.2ppm 20°-40°C, 1ppm - year aging.

- Instant Direct Tune - Set a communications receiver such as ICOM R7000 to frequency detected by counter. Patent pending.
- Data logging and data file creation to keep records or measure frequency drift.
- Menu selection for Units includes CPM/RPM, Hz, KHz, MHz, GHz, Sec, mS, uS and nS.
- Software timebase calibration of 1ppm TCXO timebase.
- Windows 3.0 operating environment with fully developed operating and signal conditioning controls accessible through pull down menus.

In addition to these unique features, PC10 is a down right high performance counter...

- 10 digit 10Hz to 2.4GHz frequency range.
- Measurement Period (Gate Time) continuously variable from 1 milli-second to 28 seconds.
- Reciprocal Counting for high resolution measurement.
- Input sensitivity is less than 10mV from 10Hz to over 1.6GHz.
- Direct count frequencies over 200MHz with 1Hz resolution in 1 sec.

OPTOELECTRONICS

Toll Free Order Line: 1-800-327-5912

FL(305)771-2050 • FAX(305)771-2052

5821 NE 14th Avenue • Fort Lauderdale, Florida 33334

CIRCLE 116 ON READER SERVICE CARD

"The Largest Dealer of Scanners in the World"

SCANNER WORLD, USA®

10 New Scotland Ave., Albany, NY 12208 • 518/436-9606

Scanner World, USA

SCANNER WORLD EXCLUSIVE UNIDEN BEARCAT BC205XLT

\$259.99 (\$7.00 shipping)

Digital programmable 200 channel hand held scanner with raised button keyboard for easy programming of the following frequency ranges: 29-54 MHz, 118-174 MHz, 406-512 MHz, 806-956 MHz.* Features include: Scan delay, memory backup, key pad lock, sidelit liquid crystal display, channel lockout, 10 twenty channel banks, direct channel access, automatic search, full one year factory warranty, 10 priority channels, Ni-Cad battery pack, AC adapter/charger, flexible rubber antenna carry case are all included. Size is 2-11/16" Wx1-3/8" Dx7-1/2" high. (Optional extended 2 yr. warranty \$29.99, 3yr. extended warranty \$39.99.) (* Excludes Cellular)
#CC-008 Heavy Duty Leather Carry Case \$27.99

RADIO SCANNERS AND ACCESSORIES

Bearcat BC145XL	\$99.99	(7.00)
Bearcat BC140	94.99	(7.00)
Bearcat BC172XL	139.99	(7.00)
Bearcat BC55XLT	119.99	(7.00)
Bearcat BC800XLT	249.99	(7.00)
Bearcat BC100XLT	189.99	(7.00)
Bearcat 8P205/200	34.99	(*)
Bearcat BC210XLT	189.99	(7.00)
Bearcat BC-ONE	129.99	(7.00)
Bearcat AD-100U	14.99	(*)
Bearcat PS-001	12.99	(*)
Bearcat VC-001	12.99	(*)
Bearcat AD-140U	14.99	(*)
Bearcat AT-054	12.99	(*)
President HR2600	219.99	(8.00)
Regency R3020	96.99	(7.00)
Bearcat BC-310A	85.99	(7.00)
Bearcat BC-330A	109.99	(7.00)
Regency MA-917	24.99	(*)
Regency MA-501	14.99	(*)
LifeGuard 4	109.99	(4.00)
GRE9001	89.99	(5.00)
GRE8002	79.99	(4.00)
Midland CB Radios	In Stock	
Cobra CB Radios	In Stock	
Uniden CB Radios	In Stock	
Silver Eagle Microphone	69.99	(*)
Antennas	In Stock	
Rechargeable Batteries	In Stock	

BOOKS

Covert Intelligence	8.95	(*)
Air Scan Directory	14.99	(*)
Betty Bearcat (Special)	4.00	(*)
Top Secret (7th)	15.99	(*)
Covert Techniques	9.95	(*)
Tomcat's Big CB	13.95	(*)
World Radio	18.99	(*)
Monitor America	5.99	(*)
Survival Directory	6.95	(*)
Rail Scan	7.95	(*)
Police Call	7.49	(*)
Scanner Modification Handbook	17.99	(*)

TWO-WAY RADIOS REGENCY-RELM

UC102	109.99	(6.00)
UC102	(2 or more) 99.99	(6.00)
RH-256NB	339.99	(9.00)
RH-606B	469.99	(9.00)
WH5-1	399.99	(9.00)
UC-202	134.99	(6.00)

REGENCY TS-1 35 CHANNELS — MOBILE/BASE

Special **\$138.99** (\$7.00 shipping)



Features include simple programming of the following frequency ranges: 29-54 MHz, 118-175 MHz, 406-512 MHz. TurboScan, digital display, priority, search, lockout, delay, dim control, top mounted speaker, one year factory warranty. Includes AC & DC cords, mobile mounting bracket, telescope antenna. All for only \$138.99 plus \$7.00 shipping. (Optional extended warranty: 3 years \$39.99; 2 years \$29.99.)

UNIDEN BEARCAT BC-400XLT

\$99.99 (\$7.00 shipping)



Our best selling mobile scanner, 16 channel, AC/DC, programmable, digital, AC/DC cords, telescopic antenna, mobile mounting bracket, weather search, priority, 29.54 MHz, 136-174 MHz, 406-512 MHz, external speaker and antenna jack.

REGENCY R-4020

100 Channel Digital Programmable Hand-Held Scanner

\$174.99 (\$7.00 shipping)



Our best price ever on a full featured complete package hand-held scanner. Manufactured by Uniden, this is the exact duplicate of the Bearcat 100XLT for a much lower price. Features include 11 bands of weather, aircraft, public service, trains, marine, plus more (29-54 MHz, 118-174 MHz, 406-512 MHz), 10 channel banks, 10 priority channels, lighted LCD display, earphone jack, channel lockout, AC/DC operation, scans 15 channels per second, track tuning. Special package deal includes following accessories: AC adapter/charger, rechargeable Ni-Cad battery pack, flexible rubber antenna, carry case.

SANGEAN ATS-803A

SHORT WAVE RECEIVER **\$168.99** (\$7.00 shipping)



AM/FM/LW and 12 shortwave bands plus FM stereo, BFO for SSB reception, clock radio. Includes AC adapter, telescopic antenna, stereo headphones, and shoulder strap.

—SHORT WAVE WORLD BAND RECEIVERS AVAILABLE—

Grundig Satellit 500	\$548.99	(10.00)
Grundig Yacht Boy 220	106.99	(5.00)
Grundig Cosmopolit	198.99	(7.00)
Grundig Yacht Boy 230	149.99	(5.00)
Grundig Satellit 650	899.99	(20.00)
World Radio & TV Handbook (1991)	18.99	(*)

SPECIAL!! LOWEST PRICE EVER FOR A PROGRAMMABLE SCANNER



SR-901

AVAILABLE ONLY FROM SCANNER WORLD

ONLY! \$74.99 Each (Plus \$6.00 Shipping Each) **\$69.99** (2 or more)



Features include: 10 programmable channels, one touch memory programming, external speaker jack, 29-54 MHz, 136-174 MHz, 400-512 MHz, squelch, lockout, full frequency digital readout, AC or DC operation, retains memory up to 3 days without power, scan button. Includes AC adapter, telescopic antenna, and complete operating instructions. Size: 7 1/4" W x 2" H x 7 1/4" D. One year factory warranty. (Optional mobile cigarette lighter cord #901MPC \$4.99)

Regency R3020

\$96.99 (\$7.00 Shipping)



20 channel digital programmable scanner, frequency coverage 29-54 MHz, 108-136 MHz aircraft, 136-174 MHz, 406-512 MHz. Features: weather key, search, lockout, priority, squelch, AC only, delay button. Size 9 1/2" x 2 3/8" x 7"

UNIDEN BEARCAT BC-600XLT

\$199.99 (\$7.00 shipping)



Digital Programmable 100 Channel Scanner

BC 600XLT covers the following frequencies: 29-54 MHz, 118-174 MHz, 406-512 MHz. Features compact size of 6-5/16" Wx1-5/8" Hx7-3/8" D, scan delay, priority, memory backup, channel lockout, bank scanning, key lock, AC/DC power cords, telescopic antenna, mounting bracket supplied, one year factory warranty, search, direct channel access, track tuning, service search including preprogrammed frequencies by pushing a single button for police fire/emergency, aircraft, weather, and marine services plus exclusive optional features never available on any scanner before. First is an RF receive amplifier for boosting weak signals for only \$24.99 plus a CTCSS tone board is available for only \$59.99 to make this the number one scanner available in the USA. Optional cigarette lighter plug #600MPC \$4.99.

BEARCAT BC-950XLT

Same features as BC-600XLT but also receives 800-954 MHz. (Excludes cellular)

\$249.99 (\$7.00 shipping)

REGENCY R-4010 \$106.99

(\$7.00 shipping each)

10 channel hand-held scanner. (Same Scanner as Bearcat 55XLT), 29-54 MHz, 136-174 MHz, 406-512 MHz, digital programmable, keyboard lock switch, lockout, includes rubber flex antenna (Optional accessory 5W-41, only \$19.99 includes rechargeable Ni-Cad batteries, AC adapter/charger and cigarette lighter cord.)



★ SCANNER WORLD HAS BEEN SELLING SCANNERS FOR OVER 21 YEARS

★ ALL MERCHANDISE NEW, IN FACTORY SEALED CARTONS

★ COMPLETE CATALOG PUBLISHED 4 TIMES PER YEAR. FREE UPON REQUEST.

BEARCAT 70XLT 20 CHANNEL DIGITAL HAND-HELD SCANNER

SPECIAL PACKAGE DEAL **\$129.99** ONLY (\$7.00 Shipping)

Small size 6" Hx1 1/2"Dx2 3/4"W. Full digital readout, priority, search, channel lockout, scan delay, key lock. Covers following frequencies: 29-54 MHz, 136-174 MHz, 406-512 MHz. Package includes rubber antenna, rechargeable Ni-Cad battery pack. AC adapter/charger and vinyl carry-case.

Optional Cigarette Lighter Cord #UA502... **\$12.99**
Heavy-Duty Leather Carry Case #CC002... **\$22.99**

BEARCAT BC-147XLT 16 CHANNEL BASE SCANNER

\$99.99 (\$7.00 Shipping)

Programmable, digital, AC/DC operation. Frequency coverage 29-54 MHz, 136-174 MHz, 406-512 MHz. Weather button, priority, lockout button, squelch includes AC adapter, telescopic antenna.

REGENCY R-2066

\$99.99 (\$7.00 shipping)



Digital programmable, 60 channels, AC base scanner, 30-50 MHz, 144-174 MHz, 406-512 MHz. Size 7 1/4"x3"x9" Turbo-Scan scans 40 channels per second, 4 channel banks, weather alert, search, priority, lockout, AC cord, telescopic antenna, plus much more.

EXTENDED WARRANTY SERVICE

This extended service contract is for all scanners, CB radios, radar detectors, and cordless telephones that have been purchased anywhere in the USA in the past 30 days. This extended warranty service begins when your original manufacturer's warranty expires.

1 year extended warranty... only \$18.99
2 year extended warranty... only \$29.99
3 year extended warranty... only \$39.99

ORDERING INFORMATION: Call (518) 436-9606 to place orders or mail orders to Scanner World, USA®, 10 New Scotland Ave., Albany, N.Y. 12208. Orders will be shipped within 24 hours by United Parcel Service if order is accompanied by MasterCard, Visa, cashier's check, money order, COD (COD shipped by United Parcel Service will be cash or money order only). (If a COD package is refused, customer will be billed for shipping and COD charges.) Mail orders with personal or business checks enclosed will be held 4 weeks for bank clearance. Prices, specifications, and terms subject to change without prior notice. If items are out of stock we will backorder and notify you of delivery date. All shipments are F.O.B. Scanner World® warehouse in Albany, N.Y. We are not responsible for typographical errors. All merchandise carries full manufacturer's warranty. Bid proposals and purchase orders accepted from government agencies only. Free full line catalog mailed 4 times per year. Merchandise delivered in New York State add 7% sales tax. No returns accepted after 7 days of merchandise receipt. * Add (\$) per item, and \$3.00* for all accessories ordered at same time. COD orders will be charged an additional \$4.00 per package. Full insurance is included in shipping charges. All orders are shipped by United Parcel Service to street address only. (No P.O. Box). Shipping charges are for continental USA only. All others ask for quote on shipping charge.

Secrets of Cellular Car Phones

All The Good Stuff They'll Never Tell You About Buying & Using Car Phones

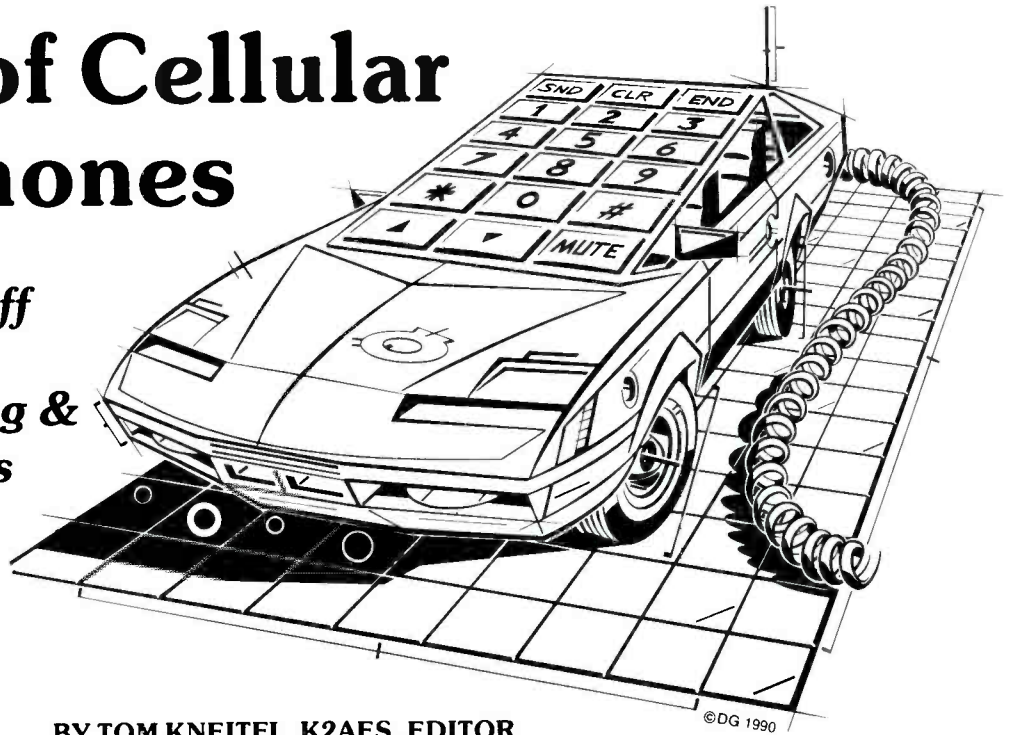

BY TOM KNEITEL, K2AES, EDITOR

There are few things quite as awesome to the uninitiated as going shopping for a cellular phone. The hapless shopper is faced with a massive array of units available in a wide range of prices, plus confusing and often conflicting claims and promises. It can get to you, and many cellular shoppers tell me that they just don't know how to sort out the factors involved in selecting the best unit. Of course, as with most types of electronics, what is really meant is the best unit for a particular need within a given price range.

Confusion Reigns

Although it's been explained lots of times, many people are confused about the frequencies used and if the cellular they purchase and register with one service supplier can be made to operate on frequencies of another company. This type of thinking might be appropriate with more traditional types of two-way systems, but with cellular systems it doesn't fly.

Without getting into a long and drawn-out treatise, suffice it to say that there are bands of hundreds of channel pairs allocated in the U.S. and Canada for cellular use. Roughly half of those channel pairs are designated for use by so-called "wireline" carriers (those companies operated by telcos), and half are allocated for use by "non-wireline" carriers (service suppliers not owned by telcos). Theoretically, each area where cellular service is available has one of each of these types of suppliers in operation and competing with one another.

Every wireline supplier has available all of the channel pairs allocated for wireline service. Likewise, every non-wireline supplier

may utilize all of the hundreds of channel pairs available for this group of companies. Cellular mobile units are manufactured to be capable of operation on all 832 channel pairs available to both categories of suppliers, and will automatically select the appropriate frequency pairs on which to operate, based upon the supplier with which a unit is registered, or may switch to in the future, or may encounter while roaming outside of the normal operating area.

Power To The People?

When shopping for a cellular, keep in mind that mobile units all have the same 3-watts of power. Transportables (usually called *bag phones*) operated by being plugged into cigarette lighters will put out as much as an installed mobile unit, but the results will be as good only if the transportable is used with an antenna mounted outside the car. A transportable using its own built-in antenna, or operated from its own internal batteries, will offer poorer results. All pocket and handheld cellulators have roughly the same power output, which is just over half of 1-watt.

Given the fact that the power output of the units in each category is essentially similar, forget about shopping around to search out "the most powerful" cellular. These aren't like ham transceivers where one runs 25 watts and another puts out 50 watts. The primary differences between one cellular and another lie in other areas, and that's part of the difference in the prices between the most inexpensive sets and the most costly units.

So what are you paying for? You may ac-

tually spend no more for some models of nationally known brands like Motorola, Mitsubishi, Panasonic, DiamondTel, Novatel, Shintom, Realistic, Audiovox, Clarion, G.E., NYNEX, OKI, Spectrum, Bell Atlantic, STS, NEC, Nokia, Pulsar, and similar than you will for many off-brands, unknowns, private label orphan brands and other so-called bargain units available. Major brands usually assure you of the best quality control during their manufacture. But it's when it comes to servicing, getting replacement parts, or dumping the set as a trade-in or in used condition, that you'll really appreciate having a unit with a brand name that's known this side of Zamboanga.

The Frill of It All

While some models of major brands may be higher priced than *el cheapo* specials, much of what you're really paying for are frills and features. That's what really separates the Machos from the Milquetoasts. When you look over the specs of the various cellulators, you're going to see features like auto dial, memory storage of numbers, security levels, hands-free, the ability to operate with two or more different calling numbers, one-button dialing, and dozens more clever and innovative ideas that makes one unit "better" than another for a particular user over and above the person who wants a no-frills unit that does nothing more than basically make and receive calls.

But, hey, lots of people don't need or want to have all of these customizing luxuries. These fancies can run up the cost like crazy. People who find no appeal in frills can shop around for units with the least amount



A handheld cellular is one of the most popular personal communications devices to reach the public. This one's a Realistic CT-301 from Radio Shack.



It's in the bag! Many people are surprised to learn that the construction trades are among the largest group of cellular phone users. Most people would bet you it's doctors driving around in their Mercedes. However the features of the units sold to both groups differ widely. (Courtesy Radio Shack.)

of bells and whistles and can shave big bucks off the price. Remember, though, that a no-frills set (like a car without air conditioning) will have less appeal than one with extras when you try to unload the thing. If you're buying the cellular on a time payment plan, you may find that some useless (to you) frills may add only a few dollars to the monthly payment and be worth the investment at trade-in time. However, no matter how deluxe a unit you purchase today, cellular technology is progressing rapidly and your new equipment may nevertheless look rather old hat when you go to get rid of it in a few years.

If you're on frugal budget and aren't familiar with cellular phone use, those cost-adding frills that look so totally unnecessary to you when you're shopping may turn out to be missed several months into the use of a bare bones phone. As you work with cellular phone operation, you could (all too late) realize that it would have been helpful to have some of those features. So, this is an area where it would be useful for you to poll several cellular users from family, friends, and co-workers before you begin serious shopping. Ask which features they have found useful; which they don't use.

If you come upon a major brand unit at what seems to be an absurdly low discount price, it may be worth your trouble to ascertain if that model is discontinued (or about to be) by the manufacturer. Aside from the fact

that it's an "older design," there really isn't anything wrong with such a set. If the savings are substantial, and you are made aware that it's not the latest model (you may not be told this unless you specifically ask or

else you find out by checking on your own), then go for it. But don't let me hear you whining when the model's new replacement is announced soon after and is something you would have preferred.

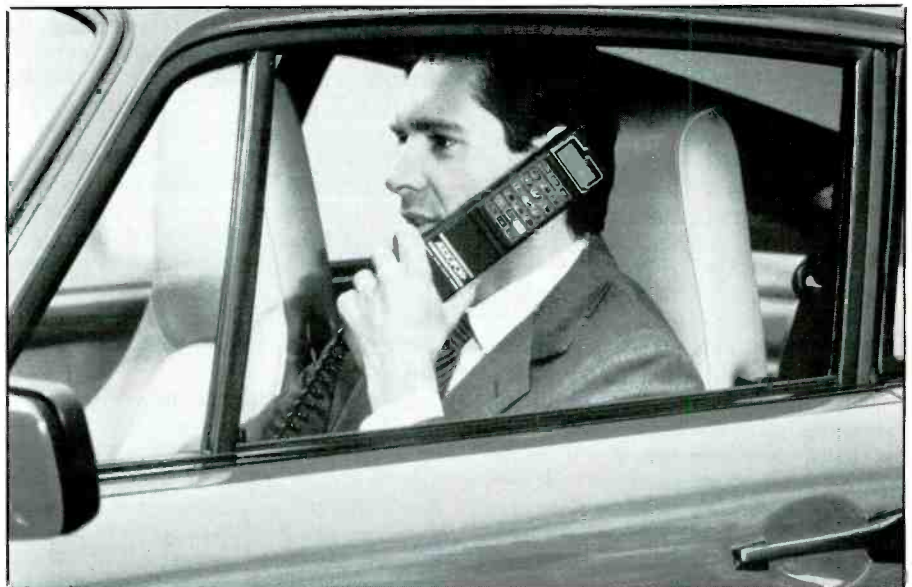

A cellular phone is only as useful as the instrument you buy, and the service provider with which you sign up. With all of the brands and deals around today, matching up with the right combination of these things requires more effort than you might think. (Courtesy Audiovox Corp.)

Hidden Costs?

There are other cost-varying factors to know about. Some cellualars are advertised with prices that look very competitive until you read the small print and learn that when you add in the accessories that are included at no additional cost with other models (like the battery pack, battery recharger and carrying case for transportables, for instance), you aren't getting the big savings you were led to believe. So, be sure to know which accessories are included and which you will have to pay extra for in order to use the unit. By accessories, I mean the things you'll really need, not optional extras you might want to buy to extend the usefulness of the unit beyond the basic specs.

Dealers sometimes run special offers where a particular brand or model of cellular is offered at considerably reduced prices as a tie-in with one of the local area cellular phone service companies. These can provide genuine and substantial savings, although the incentive offer may last only a few weeks during a drive to sign up new subscribers.

A recent offer I saw had a cellular that normally sold for \$600 being touted for only \$400 plus a two-year commitment to use the services of one particular cellular company. Still another was offering a whopping \$300 savings for a service commitment of only 90 days! Another incentive approach is offer two or three hours of free air time to those who sign up with a particular service provider. These offers, when extended, vary widely so check and compare.

Some Strings May Be Attached

Dealers are agents for local cellular service suppliers and while all are an agent for at least one of the local companies (either the wireline or non-wireline one), many can open an account and program your new cellular with a number with either of the two companies of your choice, although some dealers tend to give preference to one company over the other if the customer is indifferent or expresses no preference.

The two competing cellular service companies in your area may well offer generally similar service, but there could be subtle differences that will give you a preference of one over the other. Therefore, you might find it a good idea to compare one against the other and decide which you prefer in advance of your shopping excursion.

Look them up in the classified telephone directory under *Cellular Mobile Telephone*; *Radiotelephone Communications* or under similar headings. Call and ask them to send you information on their services, then compare their geographic coverage, the rates based upon your type of usage, reciprocal agreements with other companies in distant areas, special services offered (such as voice mail, service to 9-1-1, traffic advisories, etc.). See if they charge for Direc-

tory Assistance, Operator, and Repair Service Calls.

When you look up cellular service suppliers, you might find that there are quite a few companies listed over and above the two basic companies. This is because, in some areas, there are "cellular companies" that don't actually own any equipment to handle or process calls. They have contracted with cellular carriers to use those facilities and then resell that service to subscribers under their own name and with their own distinctive mobile telephone numbers assigned. When a dealer tells you that you are going to be placing your calls through one of the two service companies known to you, you could be surprised to find that your bills start coming to you from some third company whose name and reputation are completely unknown to you. Therefore, you might wish to inquire of the dealer if the account you are opening is directly with *this* or *that* specific carrier, or if it is to be with another company reselling that service.

The reason this might possibly make a difference is that the company reselling the service of some other company could well be offering only some of the services available from the primary supplier, or their rate structure might be less appealing. For example, they might not offer the voice mail available from the company whose services they are reselling, and that might be something you thought you'd have available.

You'll probably get a clue to the name of the service supplier when you look at whose name is on top of the credit form you are going to have to fill out when you open your account. Cellular service suppliers require that new subscribers go through an in-depth credit check. All too many people obviously don't realize they can't afford the monthly tab for using a cellular. Because cellualars are marketed with the sales pitch that they offer the convenience and privacy of a regular landline telephone, many people rationalize that using a cellular will bring them another monthly phone bill that is generally akin to that of their regular home phone. Not so. It can easily tally up to hundreds of dollars per month without very much effort at all.

Yakkety Yak Means Big Bills

There are no shortage of ratchetjaws whose service must be suspended or terminated because of unpaid bills for cellular service. Companies providing cellular phone service keep collection agencies busy. Persons with poor credit ratings probably shouldn't even think about applying for one of these accounts. Those who open a cellular account and talk past their ability to pay for the service could wreck their credit ratings.

To be candid, persons who operate on a very tight budget should not only make certain that they calculate how much use they will be able to use their cellualars, they should

BOOST RECEPTION



ANTENNA PLUS

Only \$90

Hear those rare stations you've been reading about! Make your receiver spring to life! Great performance from a tabletop box. Models for ALL BANDS, SCANNER or SHORTWAVE. Internal 15-22db amp! 115VAC pwr. Jumper cable to rcvr. NOW INCLUDED! (specify conn.)
ANTENNA PLUS-1 0.5-1300MHz "All Bands" (for wide coverage rcvrs.)
ANTENNA PLUS-2 0.3-300MHz "Short-Wave" (peaked for SWL's)
ANTENNA PLUS-3 30-2000MHz "Scanner" (peaked for VHF-UHF)

SCANNER STICK

Only \$40



Great scanner reception on all bands is yours with our new SCANNER STICK antenna. Receives all frequencies from 30 to 1000 MHz. Only 35" long and easy to install on masts up to 1.5" dia. Rugged and high quality. 25' of coax cable supplied with either BNC or Motorola connector for your scanner. (please specify)

Only \$34.95



SUCTION CUP MOUNT VAK-TENNA!

IDEAL FOR APARTMENTS, OFFICES OR RV'S

Mount to your window for the BEST SCANNER coverage! Cups hold for months! Great reception in apartments. Landlords love it! Telescopes to 79" folds to 12". 30-500MHz Choice of BNC, PL259, F or Motorola connector (specify when ordering)

TAPE SAVER

TS-1 \$59.95

Eliminates dead time on your scanner tapes!

Listen to an entire night scanning while driving to work! Interfaces scanner to your tape recorder for ACTION ONLY recording.



SIGNAL INTENSIFIERS

Make your antenna come to life!

RFP-40 1-1300 MHz! 15 DB GAIN! \$69.95



STRONGER SIGNALS for scanners, shortwave, AM-FM-TV, cable and more. 115VAC pwr. Choice of BNC, SO239 (PL259 mate) and F connectors. Battery or DC powered, remote mounted versions available. Some priced from \$34.95! (RFA161/RFA20)

CB INTENSIFIER

Only \$49.95

Improve your CB's range! The RFRTR boosts received signals by 13db! Internal T/R relay. 12VDC pwr. (AC pwr add \$10)

SSB Version \$64.95

MARINE-VHF version \$99.95



INTERFERENCE FILTERS & ACCESSORIES

SCANNER FILTER HPF-1 (passes above 45 MHz) \$8.95, SHORT-WAVE FILTER LPF-1 (passes below 50 MHz) \$19.95, ANTENNA SWITCH AS-3 3 position \$14.95; VARIABLE ATTENUATOR VA-20 \$12.95

COMPLETE LINE OF CABLES AND ADAPTERS AVAILABLE

Ask for our SCANNER/SHORTWAVE BOOKSTORE flyer.

MANY MORE PRODUCTS AVAILABLE!

SEND FOR FREE SPECIFICATIONS!

MASTERCARD and VISA NOW ACCEPTED!

Continental US shipping/handling \$5. AK, HI, PR, Canada \$8 NY and MI residents add local sales tax.

ELECTRON PROCESSING, INC.
P.O. BOX 68
CEDAR, MI 49621
616-228-7020

SATISFACTION GUARANTEED!

Order any product (except software) from EPI and if not satisfied return it within 15 days for a full refund (less shipping/handling)

CIRCLE 12 ON READER SERVICE CARD

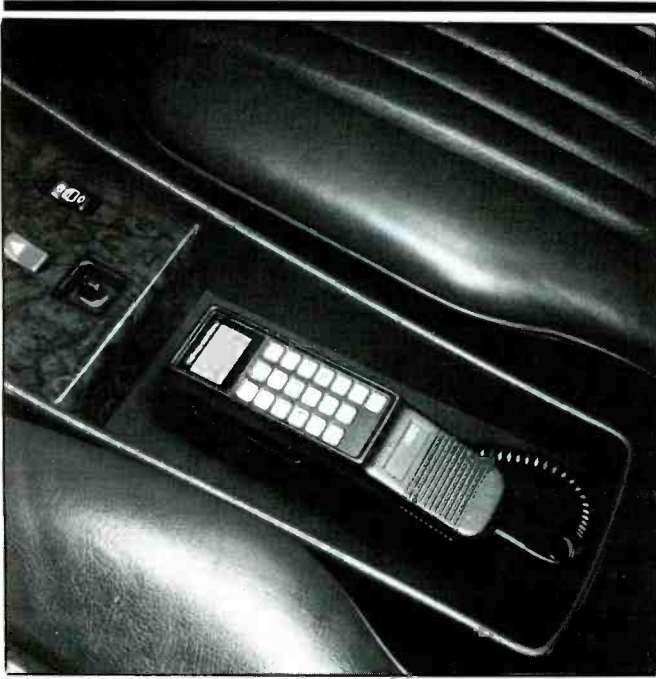

The NEC Model M4700 is a deluxe mobile cellular unit intended for permanent installation. You don't even have to answer this phone. After two rings, it answers itself and you just start talking.



A good example of a quality transportable is the Audiovox CTR-1900, which incorporates many useful features. It weighs less than 6 lbs., puts out a full 3 watts.

also carefully time their incoming and outgoing calls in order to stay within established limits, since charges are based upon the amount of per-minute air time used.

Time ticks by extremely fast when you're gabbing on the phone, and not all cellular users fully understand that (with a few special exceptions, like *US West* in Phoenix, AZ) they have to pay for incoming as well as outgoing calls. Some cellular phones feature a built-in timer to keep the user advised of the duration of every call. This is a most worthwhile feature for cost-conscious users, and is best used in conjunction with a written log maintained to show each call and its length.

They've Got Your Number!

Another wise move is *never* giving out your new cellular number to all of your friends and relatives. While it may bolster both ego and image to flash the number around, all of these people will definitely take it as an open invitation to begin ringing you up to say *hello* whenever the mood strikes. You'll realize the error of your ways as soon as your first monthly bill arrives. What's worse, you'll pay for your folly every month thereafter as your friends and relatives continue to ring you up for the novelty of talking to you on your car phone. What are you going to do then, ask them to stop calling you?

Also be aware that when you use your cellular outside of the area served by the company with which you are registered, strange things begin to happen and they aren't all good for your bank balance. One of the main reasons many folks get a cellular is because they feel it will be a great convenience

while on a trip or a vacation. Of course, in order to use the thing you must be in an area where cellular service is available, and where the local company with which you have an account has a reciprocal service arrangement with the cellular company in that city.

But what you may not know is that unless you're on a platinum plated expense account or else you are unconcerned with how much things cost, you won't want to use your cellular when you're far from home, except very briefly and only for emergencies. Don't use it to call your brother to describe the Grand Canyon, or to extol for him the glories of the lights of Times Square at night.

When you travel beyond the coverage range of your local service provider, in cellular lingo you're known as a *roamer*. That makes you subject to paying most distant host companies the hefty *roamer fees* they demand for the privilege of permitting you to inflict your tacky out-of-towner signals on their pristine facilities. Many companies demand a \$2 to \$3 *per day* service charge from roamers, *plus* as much as 75 cents per minute of air time. Add to this long distance toll charges and taxes and you've got the makings of an astronomical bill showing up in your mailbox that is the stuff from which second mortgages and personal loans are made. Consider yourself warned!

Cellular service isn't (as yet) available in many areas. If you're traveling mostly along the busier Interstates and near major population areas, service will most likely be available. But when you head off into the wilderness, rural areas, or the wide open spaces, a cellular phone may not do you much good

since you'll probably be beyond the service range of cellular companies and also your own equipment.

Even in areas where service is available, there are often isolated localized spots where coverage is poor or marginal. This could be caused by topographic features, buildings, or other obstructions between the cell sites and mobile units. If you're having a car phone conversation and enter such an area, you'll promptly lose contact with the other party. This is known as a "dropped call." Some cellular service providers may give you credit for a dropped *outgoing* call if you place the call again within five minutes, although they may give no credit for calls placed to your car phone that get dropped. They seldom volunteer information on their dropped call policy. You must ask. When comparing one company against another, it's good to know their policy on this because it can substantially run up your bill.

Cost vs. Performance Factors

When you purchase your car phone, the installation cost will be extra, as will the price of the antenna. However, watch the ads for those times when some dealers run a special "package" offer that includes the phone, antenna, and installation for a combo price that is less than the cost of each thing purchased separately. For cosmetic and performance reasons, a cellular installation is best not attempted as a do-it-yourself project by a person inexperienced in such matters.

Naturally, a transportable unit saves on installation costs, although a permanently installed antenna on each vehicle in which the unit will be operated will be useful. Or, at least get a magnetic mount mobile antenna



THE JAPAN RADIO CO. NRD-535

THE NEXT GENERATION IN HIGH-PERFORMANCE HF RECEIVERS

Once again JRC breaks new ground in shortwave receiver design. The new NRD-535 has all the features SWLs and amateurs have been waiting for. General coverage from 0.1 to 30 MHz in AM, USB, LSB, CW, RTTY, FAX and Narrow FM modes. Advanced ECSS operation for phase-lock AM reception. Variable bandwidth control (BWC). Tuning accuracy to 1 Hz possible with direct digital synthesis. 200 memory channels with scan and sweep operation. Triple Superheterodyne receiving

system. Superb sensitivity, selectivity and image rejection. Dual-width noise blanker eliminates impulse noise. Squelch, RF Gain, Attenuator, AGC and Tone controls. Optional RTTY demodulator available. 24 hour clock/timer. Easy to read vacuum fluorescent display with digital S-meter. AC and DC operation. Plus the most comprehensive computer interface found on any radio to date. Call or write today for a full color brochure, price list and dealer information.



Japan Radio Co., Ltd.

MAIN OFFICE: Akasaka Twin Tower (Main), Akasaka 2-chome, Minato-ku, Tokyo 107, JAPAN
Tel.: (03) 584-8836 Telex: 242-5420 JRCTOK J

IN U.S.A.: 430 Park Avenue (2nd Floor), New York, NY 10022
Tel.: (212) 355-1180 FAX: (212) 319-5227 Telex: 961114 JAPAN RADIO NYK



Motorola's PT500 is small enough to fit in pocket or purse. Although it's not inexpensive, it comes with lots of accessories included. There are also some optional extras available for gadgeteers who aren't satisfied without owning every possible customizing add-on.

to avoid using the transportable's built-in whip from inside a vehicle. Antennas don't always give good results from a vehicle's interior, and cellular manufacturers point out that this could possibly have an adverse affect on the operations of vehicle systems such as power brakes, electronic ignition, metering circuits, and others.

If the unit you purchase isn't installed by the seller, make arrangements for the installation with a communications or autosound shop near you. Of course, some new vehicles are now available with the cellulars as a factory-installed option and that takes away the problem.

Privacy, What?

No matter what you may believe or may be told about the privacy of cellular telephone conversations, and despite laws enacted to assure privacy, cellular phone calls are not especially private. That is to say, for all practical purposes, they are no more private than most police, fire, ham radio, taxi, and other two-way radio conversations. Persons owning scanners that can cover the cellular channels have the ability to listen to both sides of cellular conversations. Count-

less thousands of receivers that can do this are in the hands of the public.

The primary law intended to stop eavesdropping on cellular phone calls was enacted in 1986. The law has proven virtually useless because violations cannot be detected and evidence cannot be gathered. Moreover, the Dept. of Justice, which is responsible for enforcing the law, appears little motivated in that direction what with their efforts in other more important areas occupying much of their time these days.

Nevertheless, the myth of cellular privacy is often perpetuated by persons selling the equipment. This is done out of ignorance of the facts, or, in some cases, simply to conceal the truth from a customer who is concerned about his/her conversations being overheard.

Although voice scrambling equipment is available that can generally assure privacy, it isn't cheap and you'd need one unit on the car phone as well as on each home/office phone called.

As a rule of thumb, persons who normally discuss business or personal matters that are too confidential to be comfortably overheard by outsiders, should not use cellular (or cordless) phones. In any case, it's usual-

ly best to avoid using last names, addresses, or giving telephone numbers over a cellular phone unless absolutely necessary.

Shop Suey

You might avoid some problems if you shop for cellular equipment at communications or autosound suppliers, or cellular service providers. I would not recommend shopping for a cellular at general merchandise emporiums, discount houses, TV call-in shopping channels, department stores, office supply stores, camera stores, and all of the many other peripheral sources of this equipment. You want to deal with people who fully understand your requirements, can answer any questions, can offer you the widest possible selection of equipment in your preferred price range, and who adequately understand and can best point out the features and capabilities of each make and model offered. Moreover, you want a dealer who can also install and service the equipment.

These benefits are generally possible only with a supplier specializing in communications or autosound equipment. Dealers offering cellulars along with typewriters, cameras, VCR's, clothing, wristwatches, air conditioners, toasters, TV sets, jewelry, etc., are not the best ones to go to for high tech communications equipment, regardless of the enticing bargains they sometimes seem to come up with. *Caveat emptor!*

Lastly, when you purchase your cellular, be careful to keep all of the paperwork, sales receipts, warranty papers, and operating information in a safe place. If you want to carry the operating manual with the set, make a duplicate on an office copier and put the original away so it isn't messed up or misplaced. You can always run off another duplicate if need be. When the time comes to sell or trade in the phone, all of this paperwork will be something you will want to have. Furthermore, if you use the cellular for business purposes, you will want the sales receipt (as well as your monthly bills for service) for your tax records.

Serves A Useful Purpose

Whether you use a cellular in your car, truck, RV, or boat; whether you use it for personal or business purposes, or both, you are dealing with a piece of relatively expensive precision communications equipment. It's going to cost you from several hundred to perhaps more than two thousand dollars to purchase the hardware, and well over a hundred dollars a month in service charges to use the equipment regularly at even a modest level. Even if you don't use the equipment at all, you'll pay about \$15 or \$20 per month just for the cellular service provider to keep your account active.

The trick is to match your needs with the proper piece of equipment to give you the best possible service. The guidelines here are intended to give you an inside track on accomplishing this. ■

The History of Communications

(Excerpt)

Our April Issue Special, With Apologies to Miss Brannigan

BY DEL SOADY



"Repeat that part where Field Marshal Mostafa describes what I smell like."

You probably don't realize that the science of communications dates back to the era of early cavemen. These primitives didn't even have a spoken language, but instead were forced to communicate with clubs. In its earliest form, the language consisted of a single downward stroke from the club. This could be interpreted as either, "Gimme!" or "No!" depending upon the context.

As millennia rolled by, this club language gradually expanded to include more advanced concepts such as "What's happenin'?" "Don't have a cow, man!" and "Do you have a Perrier?" However, it must be noted that in order to implement this extended vocabulary it was necessary to resort to multiple club strokes, accented by varying lengths of strike. Often, as in the case of a lengthy joke, the recipient was rendered unconscious long before the point of the story (as they aptly termed it, "the punch line") was delivered.

Thus it was that desperation and necessity caused the first steps toward advancing this technology to be devised. An inventor named "Lump On Ear" showed other cavemen how to pound out their messages on the resonant skulls of dinosaurs rather than directly upon one another.

The relative ease of this new transmission method permitted this communications language to further develop and evolve. Soon, expert caveman signalers were pounding out such abstract and sophisticated messages as, "23 Skidoo," "Yo, Adrian!" "Kwabonga, dude!" and "My check's in the mail."

This technology was almost lost when the percussive eloquence of the early cave dwellers was the direct cause of the extinction of all dinosaurs. Luckily, the Iron Age was beginning and the hardy metal sufficed as the cavemen adapted and became "iron-pounders." As metal-working developed through the Bronze Age, and then the Brass Age, these people became "bronzepound-

ers," then finally "brasspounders" before their quaint and unique communications method became lost somewhere in antiquity. Occasional rumors still surface to the effect that a few persons can still send and receive messages in this most novel of all primitive technologies.

The development of long-distance communications started in 7,000 BC when the people of the Land of Babylon were the first civilization to erect permanent wooden and straw structures in clusters. This created smoke signal language. There was only one message. A column of heavy smoke was immediately interpreted by others for miles around as roughly meaning, "Hey, our village is burning down!"

But it was the emergence of spoken language that caused the next great advance in the science of communications. The rise of civilization in Sumer around 4000 BC coincided with the development of organized armies and the need to exchange long-distance tactical military communications.

In an attempt to be in contact with his field armies, King Ashur-Amadip established the world's first Signal Corps. This was a hand-selected body of individuals chosen primarily for their resonant and stentorian voices that would carry over great distances. They were deployed at intervals of a few hundred yards in a long line from the palace all the way to the encampment of his army. As each man shouted to the next, messages could be swiftly sent over long distances.

The first test of the system was on April 22nd, 3920 BC as Ashur-Amadip sent a message 160 miles from his palace in Nineveh to the army encampment at Fayetteville. The message transmitted was, in the opinion of most Sumerian scholars, a common religious catechism of the time. It was a question requiring the proper ritual response.

History records this first long-distance voice message as being, "For what reason did the pullet venture across the chariot

path?" The response to this question has been lost, so we are denied what would have undoubtedly been a rare insight into the mysteries of Sumerian religion, philosophy, logic, and intellect.

The initial trials of this system were very successful, but in actual practice, and during battles, it was found to be somewhat unreliable. One problem was that the messages would tend to become distorted as they were repeated thousands of times along the human chain, especially amidst the added sounds of war, such as battle cries, armor clanging, and 75 MM artillery fire.

In one notable instance, the King sent the message: "Send an armed party to escort the Queen to the Summer Palace." By the time the message reached the other end, it had been transformed into: "There's a party at the Queen's Summer Palace. She's waiting with open arms for escorts."

Another problem with this technology was that enemies of the king could roll up scrolls, stick them into their ears, and then stand in the bushes a half mile from the communications line. By slowly and carefully scanning their heads from side to side, they could eventually zero-in on one of the shouters in order to overhear the tactical communications. Even worse, when one of the communicators would step out of line for a few moments, they could slip their own man in and introduce bogus transmissions. During a protracted war with the Romulans, the Sumerian Royal Palace received the message, "The king smells like a goat." Another time, the entire Sumerian army was commanded to hop on one foot and flap their arms, while making clucking sounds.

After this debacle, the entire project was canceled. Many of the loud-voiced participants were reassigned to a psychological operations group whose mission it was to weaken an enemy in battle before entertaining him. That, however, is another very exciting chapter in the long history of communications. ■

Radio's Golden Era

Let's Roll Back the Clock and See How it Was!

BY ALICE BRANNIGAN

We often start off by spotlighting a major 50 kW pioneer broadcaster and how it evolved from the early 1920's. This month, for a change of pace, I'd like to salute stations that are perhaps neither as historic nor powerful, but have always been the unsung mainstay of communities from coast to coast.

There may not be nearly as much to tell you about these hometown broadcasters, but this type of station ranks high on our own personal list of favorites. Those chosen to spotlight this month are typical examples of the genre. Hard working, reliable, and dedicated to serving their communities.

A fine example is WOCB, of West Yarmouth, MA. When the station went on the air in 1944, it was the only station on Cape Cod. Running 250 watts on 1240 kHz, it was started by Basil Brewer and Hugh R. Norton from a trim looking woodframe building on South Sea Avenue. The building housed the studios, business offices, and the transmitter. WOCB's single tower, about 50 ft. tall, was put up in the back yard. In 1948, an FM outlet was put into service.

Today, with its talk format, WOCB is still serving Cape Cod on 1240 kW, although now running 1 kW. WOCB-FM is on 94.9 MHz. Since 1985, the stations have been owned by Patch Dunn & Associates of Cape Cod, Inc.

Next, let's look at WDAN, of Danville, IL. Chief Engineer Perry W. Esten first threw the main switch in October, 1938. The station was on 1500 kHz with 250 watts at that time. The station was owned by the Northwestern Publishing Co.

Not long after WDAN began operation,



Station WOCB on Cape Cod, as it looked in the early days.

the FCC changed the frequencies of many stations (and simultaneously expanded the high frequency end of broadcast band from 1500 kHz to 1600 kHz). That change put WDAN on 1490 kHz, from its studios in the Wolford Hotel. The WDAN tower was located on Washington Avenue. An FM affiliate was put in operation in May, 1967.

Presently, WDAN remains on 1490 kHz, although it runs 1 kW. Offering a large serving of programming directed at farmers, WDAN has been owned by MAJAC, Inc. for two and a half years.

How about a look at WMUU, of Green-

ville, SC? This 5 kW station on 1260 kHz began its broadcasting career in September of 1949 as a function of Bob Jones University, a fundamentalist religious college teaching "the old time religion." In 1960, an FM outlet was put on the air.

Still running religious programming, WMUU continues on 1260 kHz with 5 kW. Unlike many other religious format stations, which are non-commercial, WMUU is a commercial station. Since 1975 it has been owned by WMUU, Inc. The FM outlet, which runs a secular music format, operates on 94.5 MHz.

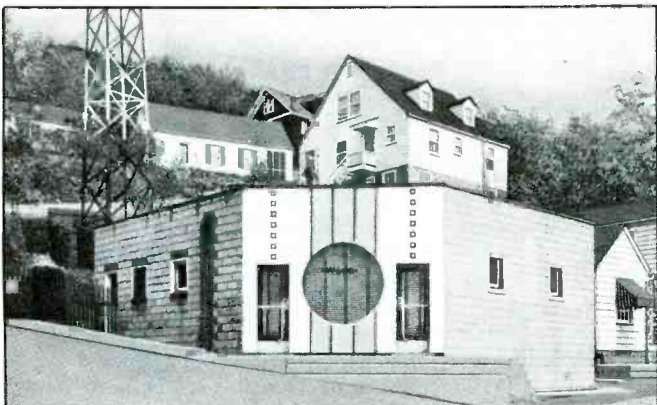

WLOG, of Logan, WV, sits perched on the side of a mountain in coal mine country. This view is from the early 1950's.



Greenville's WMUU was started by Bob Jones University, a religious college.

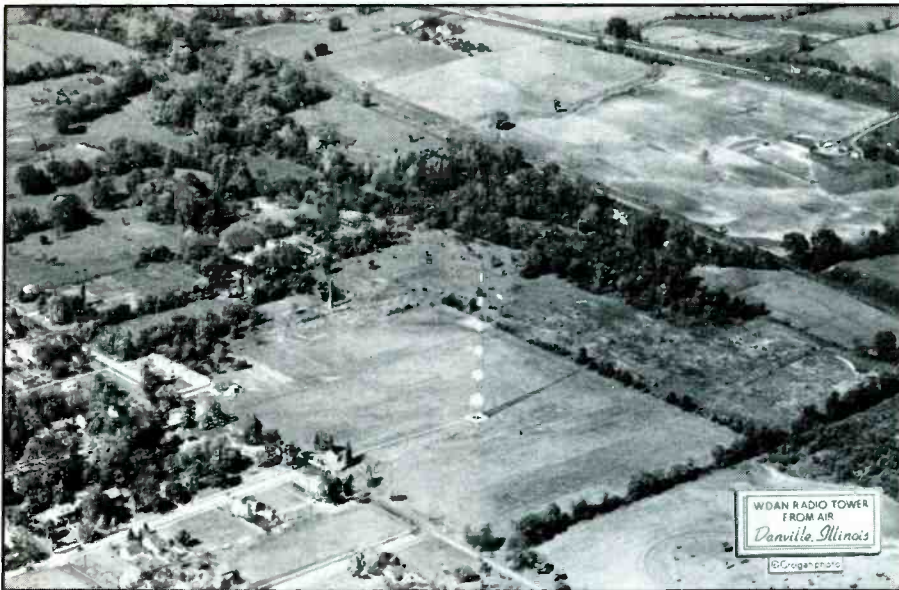

A bird's eye view of the antenna at WDAN, Danville, IL. This photo is probably from the 1950's. The antenna sits in the middle of an open field at the center of the photo.

Carthage, Ill.
October 16, 1931.

C. Robert Powell,
732 Bittersweet Pla.,
Chicago, Ill.

Dear Radio Friends:

Your report is correct. Thank You.
SUPERIOR BROADCASTING SERVICE, INC.
By/Sob Compton, Operator.

WCAZ 1070 K.C. 50 Watt.

A 1931 QSL from 50-watt WCAZ, Carthage, IL. It's hand typed and bears the name of Bob Compton, the station's founder. This station, in a scaled-up version, is still operating.

Moving to picturesque West Virginia, we'll next salute WLOG in the coal mining community of Logan. Logan is famous for its monument to Anse McCoy, of the legendary feud between the Hatfield and McCoy families. WLOG commenced broadcasting on May 27th, 1940, under the direction of Robert Greever and Clarence H. Frey. From their studios at Kanada and Chestnut Streets, the 100 watt signal went out on 1200 kHz and filled the valley.

Very soon after WLOG came on the air, the FCC shifted it to 1230 kHz. It prospered and went up to 250 watts. WLOG remains on 1230 kHz to this day, but now with 1 kW and a great classic rock format.

Lastly, this month's tribute to hometown broadcasters honors a real trooper that goes back to the very early days of broadcasting when it started out as a little one lunger. That's WCAZ, Carthage, IL, which began on 833 kHz in 1921 or 1922 (depending upon the source of the information) with 50 watts. WCAZ was started up and operated by Bob Compton on behalf of Carthage College.

When stations began moving off 833 kHz (a frequency shared by most early broadcasters), WCAZ was shifted to 1220 kHz, then (in 1926) to 1230 kHz, then to 1200 kHz, and (in late 1928) to 1070 kHz. By 1930, Carthage College was out of the WCAZ picture, and Compton had teamed up with Will H. Sohm and Walter H. Tanner to form the Superior Broadcasting Corp., at 1008 Buchanan St., later moving to 97-1/2 Adams Street., and by the late 1940's to the Marine Trust Building.

By 1935, WCAZ had increased its power to 100 watts. In 1946, it requested (and received) permission to move to 990 kHz and run 1 kW, which remains its present frequency and power. Bob Compton was still running WCAZ in the late 1940's, although these days it is operated by Tri State Broadcasting, of 84 South Madison St. WCAZ plays country and western music.

As an interesting sidebar to the WCAZ story, in July of 1925, while running WCAZ, Bob Compton had the grit to begin a second broadcast station locally in Car-

Illinois Stock Medicine Broadcasting Corporation

<p>W. EMERY LANCASTER, PRESIDENT</p> <p>ROBERT E. WHITFIELD, VICE PRESIDENT</p> <p>FRANK W. CRANE, TREASURER</p> <p>HERBERT G. KRIETEMEYER, SECRETARY</p>	<p>RADIO STATION WTAD "The Voice of Agriculture"</p> <p>Power 500 Watts Frequency 1440 Kilocycles</p> <p>Quinoy, Illinois</p> <p>January 21, 1931</p>	<p>WILL H. BOHM, COMMERCIAL MANAGER</p> <p>ROBERT CROWLEY, MUSICAL DIRECTOR</p> <p>ROBERT H. MALCOMBON, DIR. FARM PROGRAMS</p> <p>WALTER J. ROTHSCHILD, MANAGING DIRECTOR</p>
---	--	---

Studios
600 State Street

Mr. Jos. Hueter
1610 North 18th Street
Philadelphia, Pennsylvania

Dear Sir:

We have your letter in which you say you heard Radio Station WTAD on our test program, broadcast January 18. We are glad to verify your reception.

Your cooperation is certainly appreciated, and we hope you will tune in again some time.

With best wishes, I am

Very truly yours,

 W. J. Rothschild,
Managing Director.

WJR:G

WTAD was another station started by WCAZ's Bob Compton. This 1931 QSL letter was sent out after Compton sold WTAD to a company that sold cattle medicines. (Courtesy Joe Hueter, Philadelphia, PA.)

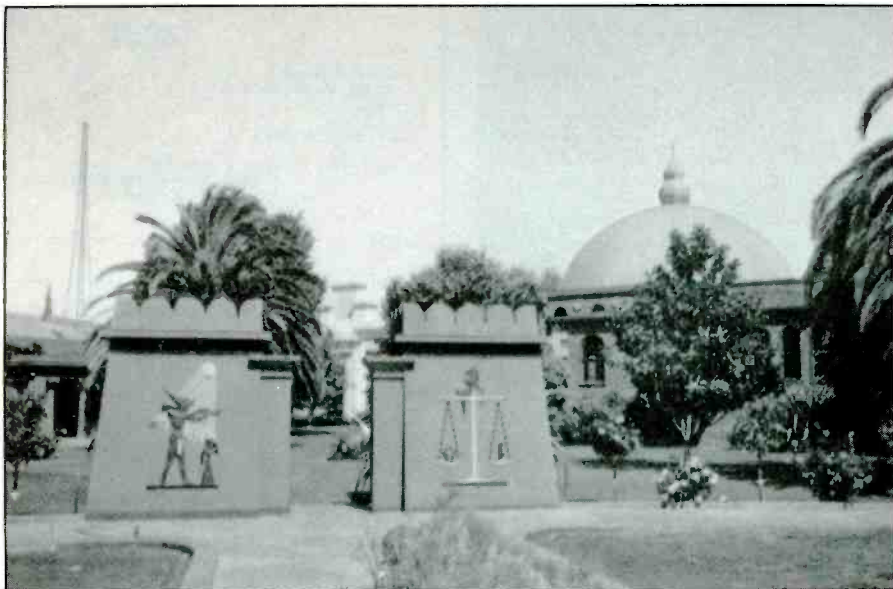

This old photo of Rosicrucian Park, San Jose, CA shows a radio tower over to the left. Can any reader supply information as to its use?

thage, IL. That was WTAD, on 1270 kHz, which he ran on behalf of the First Presbyterian Church. In the late 1920's, WTAD was sold to Will H. Sohm (later to be a partner in WCAZ), who licensed it under the name Illinois Stock Medicine Company, and moved to Quincy, IL. WTAD (*The Voice of Agriculture*) ran as a 500 watt station, and by late 1928 it was operating on 1440 kHz. By the mid-1930's, WTAD had moved to 900 kHz under new owners, and eventually (under yet other new owners) to 930 kHz with 1 kW. When Bob Compton started these little 50 watt stations, they were charmed! That's why WTAD remains on the air! It's still in Quincy, and has been

under the ownership of Tele Media Broadcasting Corp. of Quincy for more than two years. It runs 5 kW on 930 kHz and probably doesn't realize that it has a long lost brother living in Carthage!

Mystery Photo Department

An undated postcard (probably from the 1950's) was sent in by a California contributor who asks if we can identify the station using the radio tower shown in the photo. This is a photo of the entrance to Rosicrucian Park, in San Jose, CA. The park is the North American headquarters of the Rosicrucian Order, and all buildings are con-

structed in Egyptian style architecture. From what I can find out, the Rosicrucian Order is an organization that offers mystical teachings they claim are based upon certain philosophies of ancient peoples.

Just to the left of the left gate, and in the background, there is a tower of some kind poking up above the skyline. It is possible that there is more to this antenna than can be easily seen in the photo. Under magnification, there seems to be a thin rod atop the tower. This could be, or support, a VHF, FM, or TV broadcast antenna. We have no thoughts on what the tower might have been used for, or if it still exists. If any readers can fill in the blanks, we're all ears!

In the November issue we ran a mystery photo from the early days of wireless, and showing a scene described as "Fowl Bay Showing Government Wireless Station, Victoria, B.C." Our guess was that the station located on top of the hill may have been VAK. Still, we requested confirmation. In response, we received excellent information submitted by Rodger Henly, VE7DZD, of Victoria, B.C.

Rodger agrees that VAK was correct as being the station shown in the photo. VAK moved out of the magnificent old building in 1940, although the structure on the hill still stands (minus the radio towers shown in our old photo) and now serves as a government weather station. VAK was moved to Sooke, B.C., a few miles west of Victoria where presently it is operated by the Canadian Coast Guard on 2054, 2182, and 2458 kHz SSB, also VHF 156.20, 156.80, and 157.10 MHz.

Rodger also took a photo of the same scene shown in the old photo so we could see how everything looks more than 70 years later. The government building on top of the hill can still be seen, along with another structure just to its right, but Rodger points out that "time and real estate development wait for no one and the old building now has lots of expensive neighbors these days."

Indeed, all of the waterfront summer cottages of old have been replaced by luxurious year-round homes, and a layer of new waterview homes has been added to the side of the hill.

Radio Museum Information

From time to time we receive information on communications museums and exhibits, and are pleased to pass it along. SSgt Alan DesJardins (USAF), of San Angelo, TX brought two to our attention.

First, there's the E. H. Danner Museum of Telephony. This museum has been in San Angelo for many years, but had been somewhat inaccessible to the public inasmuch as it was located in the offices of GTE. Recently, the museum was moved to Officer's Quarters No. 4 at Old Fort Concho, a historic landmark and popular tourist destination.

This museum traces the history of the telephone back to experiments that began as

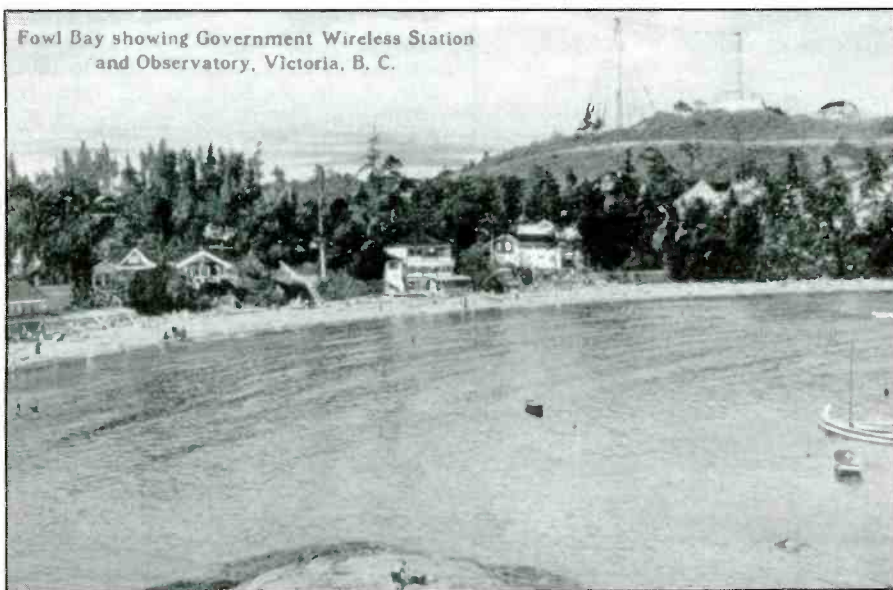

A view of the "Government Wireless Station" (to the right, on top of the hill) at Victoria, British Columbia. This shows how it looked about 1920, as seen in last November's issue.

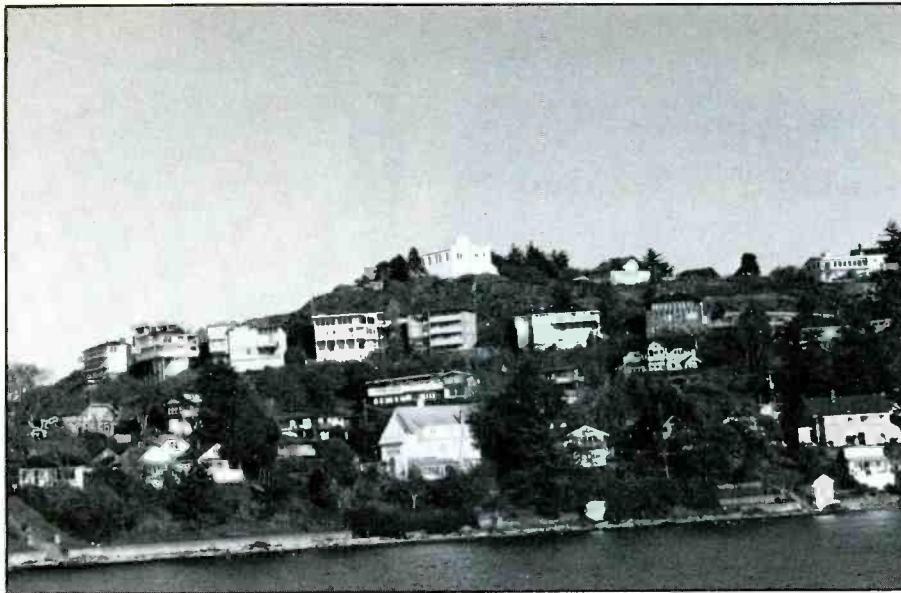

The scene at Fowl Bay, Victoria, B. C., as it looks today. The former wireless station building is still on the hill. (Courtesy Rodger Henley, Victoria, B. C.).

early as 1664. Displays, demonstrations, and actual old telephone instruments from earlier eras are to be seen at the Danner Museum.

The Danner Museum is open Tuesday through Saturday, 10 a.m. to 5 p.m., also Sunday from 1 p.m. to 5 p.m. Admission is free. For more information, call (915) 653-0756, or write Danner Museum of Telephony, Fort Concho Museum, 213 East Avenue D, San Angelo, TX 76903-7099.

Alan further points out that San Angelo also has the Audrey Lewis Museum, located at the studios of radio station KGKL-AM/FM, 1301 South Bryant. This is also free, and the sort of place that any radio buff won't want to leave. The Audrey Lewis Museum (named for a former KGKL General Manager) contains a very old working broadcast studio, complete with receivers, station logs, and other nostalgia. Alan notes that the people there are very friendly and also extremely knowledgeable.

KGKL went on the air in 1928, so our guess is that the items displayed are from the station's own early days. It might be best to check with KGKL in advance to find out the days and hours of this fascinating display. Their number is (915) 655-7161.

Calling WWII Signal Corps Members

The command historian for the U.S. Army Signal Center at Fort Gordon is planning a historical study about the Army's Signal Corps during World War II.

The command historian is particularly interested in first hand accounts of Signal soldiers, including diaries, letters, and reminiscences. However, other records also are welcomed including reports of chief Signal officers, Signal Corps bulletins, special stud-

ies, after-action reports, photos, scrapbooks, campaign maps, Signal Corps manuals, films, and instructional materials.

If you have any of this material and would like to loan or donate it to historical study, please write to the Command Historian's Office at USASC&FG, Fort Gordon, GA 30905-5000. If you desire more information, call the Command Historian's Office at (404) 791-5212, or (404) 791-3920.

Good Morning, Vietnam

In the March '90 issue we ran a QSL from Armed Forces Vietnam Network (AFVN) dated 1964. This QSL had lots of stations and frequencies listed, but we confessed that we were unable to provide further information on that data based upon archival data we had for 1964.

Letters from Billy F. Williams, Jr., N4UF, of Jacksonville, FL, and also from Donald J. Weber, Westlake, OH both comment that the reason we were stumped was because of the peculiar date on the QSL. They pointed out that the call AFVN was not officially used until 1967, and the data on the QSL would seem more logical as 1969 than five years earlier. Most likely, we misread the handwriting on the QSL which looked like 1964 to us, but was obviously a strangely penned 1969.

Billy Williams, Jr., who was an announcer and engineer with AFVN from 1971 to 1972, is a radio historian specializing in American radio in Vietnam. He advises that, prior to 1967, the 540 kHz station was at Cat Lo (near Saigon) with only the other low powered (10 to 50 watt) repeaters at American bases. In 1967, when AFVN was formed, other high powered stations were put on the air. These included DaNang (850 kHz, 10 kW); Qui Nhon (770 kHz, 10 kW);

SWL
AMERICAN FORCES VIETNAM NETWORK

<i>AM</i>	
540 KHZ	50 KW (K)
560 KHZ	50 KW ()
770 KHZ	10 KW ()
850 KHZ	10 KW ()
900 KHZ	10 KW ()
930 KHZ	1 KW ()
1200 KHZ	1 KW ()



"FOR THE FIGHTING MAN"

WE ARE PLEASED TO VERIFY YOUR RECEPTION OF THE ABOVE LISTED AMERICAN FORCES VIETNAM NETWORK RADIO STATION ON 15 APR 67 AT APPROX 23:00 HOURS VIETNAM TIME. THANK YOU FOR YOUR INTEREST IN THE AMERICAN FORCES VIETNAM NETWORK.

We ran this AFVN veri last March, but it seems that it should properly have been referred to as being from 1969, rather than 1964 (which is how we read the info). (Courtesy R.C. Watts, Louisville, KY.)



AFVN's Sgt. Jim Huntley, shown in Saigon back in 1971. Jim was host of AFVN's "Power of Music" show.

Cam Ranh Bay (900 kHz, 10 kW), and several others. Thus, AFRS-Saigon (1962-1967) evolved into AFVN (1967-1973).

Donald Weber notes that towards the last days of the war, in the spring of 1972, the AFVN sked listed the following stations: Saigon on 540 kHz; Pleiku on 560 kHz; DaNang on 850 kHz; Nha Trang on 900 kHz; Hue and Phu Bai on 930 kHz; and Qui Nhon on 1290 kHz. The sked pointed out that Qui Nhon on 770 kHz, Cam Ranh Bay on 900 kHz, and Dinh Tuong on 1200 kHz had all gone dark. By 1972, all stations still in operation were using far less power than in earlier years.

Certainly, every member of the military, and the many American civilians (CIA, Air America, etc.) in Southeast Asia received many hours of enjoyment and information from these worthy broadcast activities. Bring back the old *Mick and Mai* show! Maybe now we'll call it *Mick and Mostafa*.

By the way, N4UF (who, incidentally, happens to be the DX Awards Manager of *CQ Magazine*, one of *POP'COMM's* sister publications) has research material and tapes from AFRS and AFVN radio and TV. Anyone interested in purchasing AFVN souvenirs (research articles, baseball caps, program tapes, etc.) can contact him at: Bil-

ly F. Williams, Jr., N4UF, Box 9673, Jacksonville, FL 32208.

Undoubtedly because of the current events in the Middle East, there has been a recent burst of interest in broadcasting and military two-way communications relating to the war in Southeast Asia. Practically no information had ever surfaced in the past, and a few rare and precious pieces of this previously hidden history are just now beginning to emerge. Our advice is to start assembling any data you can while it's available.

Good Night, Vietnam

After the end of American involvement in Vietnam, broadcasting activities there were best known as the *Voice of Vietnam*, operated by the government of the Socialist Republic of Vietnam.

What had once been called Saigon had become Ho Chi Minh City, and was operating on 720, 870, 6165, 7245, and 9620 kHz. Hanoi was holding down the fort on a multitude of frequencies: 587, 803, 830, 830, 1010, 1240, 3997, 4713, 4860, 4932, 4994, 6425, 6450, 7080, 7385, 7417, 7470, 9448, 9887, 20010, 10040, 10060, 10025, 12035, and 15012 kHz.

The *Voice of Vietnam* still operates from these and other locations, and some of the



In 1971, AFVN's popular "Diana, the USO Show Time Girl" was on the air daily.

old frequencies are still employed. In fact, the station salvaged and put into use many of the old AFVN transmitters after moving them to locations better suited to its own needs. They also use many of the old VTVN (*Radio Vietnam*) transmitters that had once been operated from Saigon by the former Republic of Vietnam (South Vietnam).

Owen Williamson, of El Paso, TX, donated a large QSL collection to the POP'COMM archives. This collection contains a fine example of a 1978 QSL from the *Voice of Vietnam*.

Good Night Mrs. Calabash, Wherever You Are!

That's all we can fit in for April, although there's enough left here to allow me to rattle on for a lot more. Please come back next month, though. We look forward to input from readers in the form of old QSL's (originals, if you can spare 'em, or else good quality copies), photos of old broadcasting or wireless stations, old station directories, etc. Thanks to all who all who have generously submitted items and reference materials. ■

PC HF FACSIMILE 5.0 \$99



NOW EVEN BETTER!

A complete facsimile reception system for the IBM PC and compatibles. Receives in 16 intensity levels for full gray scale images.

Includes:
Demodulator
DSP Software
Worldwide FAX Directory

200 Page Manual
Tutorial Cassette
Interpretation Guide

Features:

Printer output, Disk Storage, Automatic operation, Programmable line rates, IOC, LCD support, Integrated file management and more.

PC GOES/WEFAX \$250

Designed to decode the AM subcarriers from U.S., Soviet and Chinese meteorological satellites. The product includes the demodulator, DSP software, orbital tracking system and many professional image processing features. Call or write for product information.

Software Systems Consulting

150 Avenida Cabrillo, "C", San Clemente, CA 92672
(714)-498-5784

CIRCLE 6 ON READER SERVICE CARD

THE VOICE OF VIETNAM

58 Quan Su Street — Ha Noi
Socialist
Democratic Republic of Vietnam

To Mr Owen Williamson Date 30 June 1978

VERIFICATION

Thank you for your report of reception

at 13^h GMT 10.040 MHz

on 20 mai 1978

All details check with our log.

Regular reception reports with detailed remarks and suggestions on programming and technical matters are highly appreciated.

Enclosed are.....

Yours faithfully
THE VOICE OF VIETNAM
FOREIGN LANGUAGES TRANSMISSIONS



"Yankee Go Home!" We did, and "The Voice of Vietnam" took over the airwaves, and also most of the former AFVN transmitters. This 1978 QSL confirms reception on 10040 kHz. (Courtesy Owen Williamson, El Paso, TX.)

POP'COMM Reviews:

MFJ Enterprises' MFJ-1278 Multi-Mode Data Controller

Have you wondered what those rather strange sounding signals are while listening on HF or VHF? It is a good chance that you've tuned across one form of digital communications used by communicators around the world, including ham radio operators, ships at sea, the military, and many others. Are you interested in "getting in on this action"? If so, read on, as MFJ Enterprises MFJ-1278 Multi-Mode Data Controller allows you not only to receive this exciting form of communications, but to transmit as well if you should possess the proper license to do so.

The MFJ-1278 has eight different modes of operation, with another sub-mode (a Morse code contest memory keyer) included for even more versatility. These eight modes include: packet radio, Baudot RTTY, ASCII, AMTOR, NAVTEX, Morse code, SSTV (Slow Scan TeleVision), and FAX. The FAX and SSTV modem in the unit permits the transmission and reception of multi-gray level pictures with an appropriate terminal program, such as MFJ's MultiCom™ software program which was supplied for this review. I highly recommend this optional program, as it is menu-driven and very easy to use.

Since the MFJ-1278 is a "data controller," this implies use with a separate terminal or a computer using a terminal-emulation software program. Therefore, in addition to the MFJ-1278, you will need your receiver (or, transceiver, if you are a ham) and a terminal or computer. The well-written 368-page instruction manual (with schematic drawings) and a separate 19-page Fast-Start™ manual gets you "up and running" very quickly. The unit is supplied with the

PTP Terminal Program for IBM-compatible computers. Physical hook-up and software installation on my "IBM clone" was very straight forward thanks to the Fast-Start™ manual. Once you have it all connected together and the software installed, you are ready to listen to some of the most interesting communications on the air today.

Operation couldn't be made much easier, thanks in a large part to the MultiCom™ software package. Admittedly, the MFJ-1278 is a complex unit with significant capabilities, but MultiCom™ makes it a cinch to use. The unit performed well on all modes. Copying WeFAX (weather facsimile) with the unit was enjoyable as well as informative. Space does not permit a complete mode by mode description of its operation, but suffice to say the MFJ-1278 performs as claimed by the manufacturer. Both the built-in 20-segment LED tuning indicator and parallel printer port add to the unit's performance.

If you should want to join the "fun" of monitoring digital communications and own a computer, you should give strong consideration to the MFJ-1278 as its overall capabilities and performance are very good considering its price range. The basic MFJ-1278 is priced at \$279.95 and MFJ-1278T "Turbo" (as reviewed here) is priced at \$359.95. The "Turbo" adds a 2400 baud modem, in addition to the standard 300/1200 baud modem in the basic MFJ-1278. The MFJ-1278 MultiCom™ software package is priced at \$59.95. For more information, contact MFJ Enterprises, Inc., Box 494, Mississippi State, MS 39762. ■

Reviewed by POP'COMM staff.

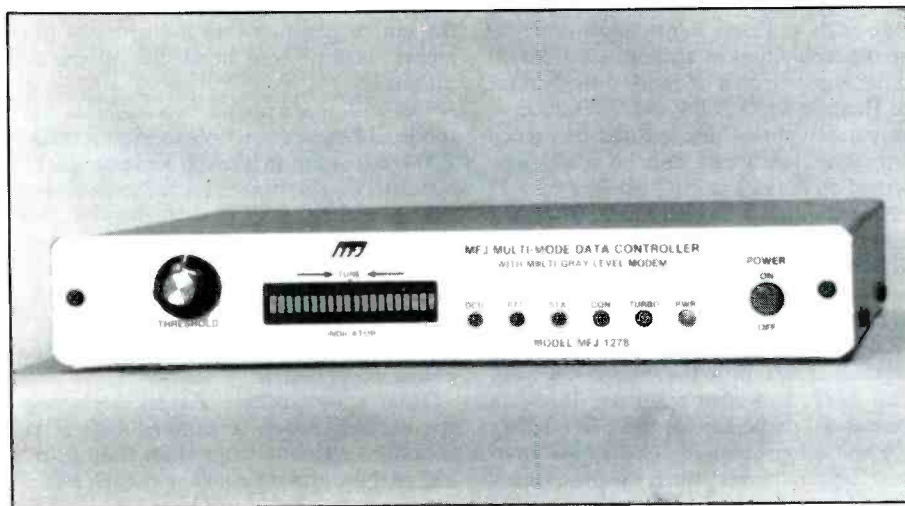

Receive digital signals on shortwave

See AP wire news photos, weather maps, news over RTTY, Amtor ship-to-shore, Navtex, slow scan TV, ASCII, Morse code and packet radio -- all on your computer screen!



MFJ-1278

\$279.95

See tomorrow's news today on your computer screen when you copy crisp, clear AP news photos. You'll also

enjoy high resolution WeFAX weather maps, multi-gray SSTV pictures and full color packet radio pictures. You'll also copy the digital text modes: RTTY, Amtor, Navtex, ASCII, Morse and packet.



AP wire photo received on 20.738 MHz using MFJ-1278 with MFJ-1289 Multicom.

All you need is the MFJ-1278 multimode data controller, HF and/or VHF/UHF receiver and your computer with MFJ software.

Don't be confused by a barrage of unknown digital signals -- let Automatic Signal Analysis™ tell you what they are

MFJ-1278's ASA™ detects RTTY, Amtor, ASCII and HF Packet signals. After ASA tells you what you're hearing, you just type an "OK" command to display the copy on your computer screen.

MFJ Multicom™ and MFJ Multicom64™ -- software that brings out the full power of your MFJ-1278 with multi-gray modem

MFJ Multicom™ for IBM compatible computers (MFJ-1289, \$59.95) gives AP photos and weather

maps with up to 8 gray levels. MFJ Multicom64™ (MFJ-1282B \$39.95) gives you multiple gray levels on your Commodore 64/128.

These programs include a computer cable and friendly instructions --

everything you need to get started fast.

To enjoy receiving text modes off the air with your MFJ-1278, you can use any computer with a serial port and simple terminal program.

Feature packed for superb operation

Dual radio ports let you connect two radios (each HF or VHF/UHF); 20 LED precision tuning indicator lets you tune in signals to an incredible 10 Hz accuracy -- even if you don't have digital readout; free AC power supply (or use 12 VDC); RS-232 and TTL serial ports make it easy to use with virtually any computer; one year unconditional guarantee and much, much more.

Enjoy an exciting new world of SWLING

Enjoy thrilling multi-gray AP news photos, weather maps and digital text with the MFJ-1278 multimode data controller. Get yours today!

Nearest Dealer/Orders: 800-647-1800

MFJ MFJ ENTERPRISES, INC.
Box 494, Miss. State, MS 39762
(601) 323-5869; FAX: (601) 323-6551
Add \$5 each product ordered s/h.

MFJ . . . making quality affordable

Gigantic Reference Source

The *Encyclopedia of Electronics, 2nd Edition*, by Stan Gibilisco and Neil Slater, looks to be about as comprehensive as anybody could hope for. Let's put it this way, it's a hardcover book containing almost 1,000 pages, more than 1,100 illustrations, and it weighs four and a half pounds.

Simply put, this is a magnificent reference source covering just about every conceivable area of electronics. It isn't one of those books filled with little two-sentence capsule definitions. This book provides enough information on each topic covered to give you a basic understanding of what it's about. The information is provided in terminology and language that should be able to be readily understood by the average person. In fact, I'd say that it was written for use primarily by hobbyists.

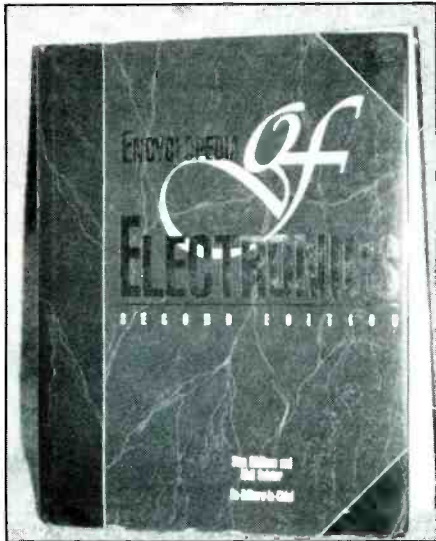

In fact, the book is far more than its title implies. In addition to electronics, it also includes those concepts in math, physics, computer science, and chemistry that have a tie-in to electronics. The most recent advances in digital electronics, IC's, computers, and communications are covered, as are things such as robotics, HDTV, superconductors, fiberoptics, FAX, CD's, artificial intelligence, and numerous other high concepts.

Information is arranged alphabetically, and is indexed and cross-referenced. There are plenty of photos, schematics, charts, tables, graphs, and diagrams used to clarify the information presented. In other words, a monumental work in every respect. The earlier edition of this book was selected by the American Library Association as one of the "Best Reference Books of the 1980's."

This reference book covers it all, from *abscissa* to *zinc-carbon batteries*, and every-

thing between. It isn't explained in the *Encyclopedia of Electronics, 2nd Edition*, it might well not really exist.

The book is \$69.50 (\$92.95 Canadian) plus postage, from TAB Professional and Reference Books, Blue Ridge Summit, PA 17294-0850. The book number is 3389.

More Great Scanner Enhancing Modifications

No doubt about it, Bill Cheek's *Scanner Modification Handbook* created nothing short of a sensation last year. The first printing sold out in only two months, and it has since gone on to become a standard and important manual for scanner owners. And why not? In its 160 pages, it's got step-by-step instructions that show the average scanner hobbyist how to restore factory locked-out cellular frequencies, speed up search/scan rates, add more memory channels, and perform other improvements in some of the most popular scanners, most especially the Radio Shack Realistic PRO-2004, PRO-2005, and PRO-34.

Bill Cheek, legendary scanner hacker, has emerged again from his secret laboratory to reveal more great enhancements, and performance improving modifications for scanners such as the Radio Shack Realistic PRO-2004, PRO-2005, PRO-2006, PRO-2022, PRO-34, Uniden Bearcats BC-200/205XLT, BC-100XLT, BC-760/950XLT as well as other current scanning receivers. They're in Bill's big all-new 220-page *Scanner Modification Handbook, Volume 2*. It's fully illustrated with photos, schematics, tables, and has step-by-step instructions to make everything as easy as possible. The eighteen mods should be able to be accomplished by the average hobbyist using common equipment such as wire cutters, soldering gun, etc.

Bill first takes a long look over the modifications in the earlier volume, reviewing them with updated information and improved techniques as appropriate. This includes showing how all mods described for the Realistic PRO-2004 and PRO-2005 in the earlier volume (like cellular frequency restoration, etc.) can also be easily performed on the newer PRO-2006.

Next, he gets into new mods. There's a high performance analog S-meter for the PRO-2004/5/6; plus a digital LED S-meter for the same units. There are analog and digital center tuning indicators for the PRO-2004/5/6. There are methods of varying the scan-delay time in the PRO-2004/5/6, PRO-2022, and other scanners. There's a "carrier-on" indicator for the PRO-2004/5/6 and other scanners, also a new automatic tape recorder switch for these scanners. You'll learn how to put electronics in-

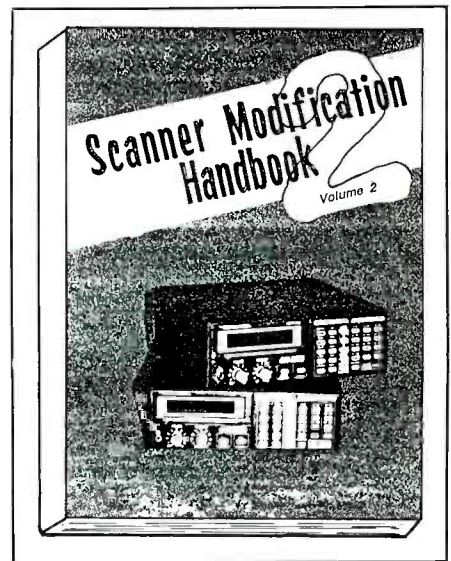

terference shields around scanners housed in plastic cases.

Owners of Realistic PRO-2022 scanners will learn how to restore the locked out cellular bands, how to speed up scan rates, and how to give the set 3,200 memory channels. Realistic PRO-34 and Uniden BC-200/205XLT owners will find out about revving up the scanning speed of those units. Those who have had difficulty restoring the cellular bands in Uniden Bearcat BC-200/205XLT and BC-760/950XLT scanners will see alternate approaches that should provide the results sought. Those who have had problems with short battery life in Uniden handhelds will find an excellent solution. There's also a CTCSS decoder you can put into a Realistic PRO-2004/5/6 and other scanners. One or two mods, like the keyboard memory block controller for 6,400 channel Realistic PRO-2004/5/6 units, are applicable to equipment that had been previously modified from instructions in the earlier volume, and, in such instances, the author assumes that the user has the earlier volume on hand for reference purposes.

But wait, that's not all. In addition to the mods, Bill shows you how to align a PRO-2004/5/6 using an S-meter and a couple of bench tools, also how to record scanner audio on a 6-hour VCR videocassette. He shows you how to build two simple bench power supplies, and how to improve audio output from your handheld scanner. He shows you how to build a "Super-Snoop" DTMF tone decoder for scanner and telephone experiments.

There's an excellent chapter explaining the different types of trunked 800 MHz communications systems, how they operate, and the specific challenges each offers to scanner owners. You'll learn how (and if)

to buy a used scanner, and how (and if) to bother with beginning a collection of "antique" scanners. There's more, too! Too much to completely enumerate here.

I've made many mods to my scanners from the original volume and also from the new Volume 2. They all went well and were easy to follow. Moreover, they greatly enhanced the performance, versatility and value of my equipment. So, I can happily give you the first hand report that I really breezed right through them without a hitch, despite the fact that I am the original "Mr. Allthumbs." Volume 2, which was just issued, is a most welcome addition to Bill Cheek's *Scanner Modification Handbook* series.

Scanner Modification Handbook, Volume 2, by Bill Cheek, is available from many leading communications suppliers. It is also available by mail directly from the publisher, CRB Research Books, Inc., P.O. Box 56, Commack, NY 11725. The book is \$17.95, plus \$2 postage to USA/Canada/APO/FPO addresses. Residents of NY State, please add \$1.35 sales tax. The earlier *Scanner Modification Handbook, Volume 1* is also available at \$17.95, plus \$2 postage (and \$1.35 tax for NY State residents). If both volumes are ordered by mail at the same time (\$35.90 for the two volume set), include only \$2 postage for one book and the second book will be mailed at no additional postage cost. Good deal!

Computer Crimes

Every business that relies on computers is vulnerable to industrial espionage, breaches of security, and employee waste and fraud. A publication entitled, *Computers: Crimes, Clues, and Controls* details effective steps to prevent unauthorized access, alteration, disclosure, and destruction of computerized information, and outlines a comprehensive program of prevention, detection, and control of computer crime and misuse.

Computer crime has become a fast-growing area of criminal activity, causing significant financial losses as disgruntled and unscrupulous employees, or formerly honest employees facing personal financial pres-

ures, press a few keys on a computer terminal that enhance their own wealth. As is often the case, such schemes are so cleverly constructed and insidious that the poor employer hasn't the foggiest notion that he's suddenly acquired several silent partners.

But, of equal concern is computer-related waste and opportunities for abuse caused by just not knowing how to safeguard information sources. An open, unlocked door is an invitation to be ripped off. Likewise, unsecured information invites its own theft or tampering.

This worthy book is designed to heighten your information security awareness and increase your knowledge of the vulnerable areas and potentials of electronic information systems. It deals with three main areas, information security, physical security, and personnel security. Then, it formulates a plan of action to establish protection for a company's valuable files, records, accounts, and other data stored in data banks.

Computers: Crimes, Clues, Controls is \$10.00, plus \$3.50 postage, from Paladin Press, P.O. Box 1307, Boulder, CO 80306. Residents of CO, please add 37 cents sales tax.

Advanced Crypto Challenge

A book called *Breakthrough '32: The Polish Solution of The Enigma*, by C.A. Deavours, is an advanced text on modern cryptanalysis, not intended for the beginner. Accompanying the book is an MS-DOS 5.25" floppy for an IBM PC.

In *Breakthrough '32*, there are a series of BASIC and "machine language" programs that permit the retracing of the historic path taken by Polish codebreakers in their solution to the famous Enigma machine used by the Germans. The solution process is interactive, so you get the feel of performing the solution yourself. *Breakthrough '32* contains numerous computer programs to aid in the solution of the Wehrmacht's 1932 Enigma machine, whose simulation is provided by another program. Indeed, there are several programs included that will automatically generate a full exchange of Enigma messages, complete with radio call signs!

Breakthrough '32 is \$48.80, plus \$2 postage, from Aegean Park Press, P.O. Box 2837, Laguna Hills, CA 92654. Residents of CA, please add \$2.93 sales tax.

We were sent a review copy of a scanner newsletter called the *Virginia Monitoring Digest*. As its name implies, it is a publication devoted to stations, systems, and frequencies within Virginia. This is a monthly publication and the edition we saw was ten pages in length. It has been in operation since mid-1990. The edition was very good looking and contained lots of useful information submitted by contributors who seem to be well versed in their respective topics. Some of the areas covered in the edition included the state police, shopping malls, highway

A CRYPTOGRAPHIC SERIES 51

BREAKTHROUGH '32

THE POLISH SOLUTION OF THE ENIGMA

INCLUDES MS DOS 5-1/4" DISKETTE FOR IBM PC

Computer programs — written in BASIC and machine language — provide the serious cryptanalyst the following —

- Simulation of the 1932 Wehrmacht ENIGMA machine.
- More than a dozen specially designed programs to aid in the solution process.
- Message generation system for constructing problems.
- Rotor lockup and cycle catalog programs for building more extensive solution facilities.

by
C. A. Deavours

■ From Aegean Park Press

maintenance, plus information on various local and county public safety systems. A fine newsletter for Tidewater scanner monitors. *VMD* costs \$20 per year (copies mailed by First Class Mail). Samples are \$2 each. Order it from John C. McColman, P.O. Box 1031, Chesterfield, VA 23832. Checks must be made payable to John C. McColman, and not to *VMD*.

Jo Gunn Enterprises

- CB Antennas
- 10 Meter Antennas

- Mobile Antennas
- Coax

Local - Groundwave - DX
Combination Antenna

JG-4 STAR

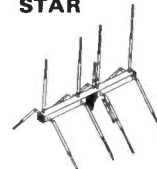

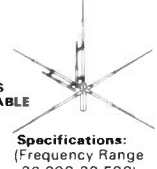

Specifications:
Type: Horz. & Vert.
Polarization: Twin Feed
Gain: 15.5 DB
Front to Back Ratio: 25 DB True
Side Rejection: 45-50 DB True
Back Rejection: 45 DB True
Weight: 34 Pounds
Length: 12 Feet
SWR: 1.1
Horz. to Vert. Separation: 20-25 DB
Wind Survival: 100 MPH
Power Multiplication: 50X
Audio Gain: 20 DB
Wind Load: 3.7

JGAR HILLBILLY



UPS SHIPPABLE

Specifications:
(Frequency Range 26,000-29,500)
Gain: Horizontal - 5.25 DB
Vertical - 4.75 DB
Multiplication Factors:
Horizontal - 17 Times
Vertical - 15 Times
Horz. to Vert. Separation: 20-25 DB
Power Rating: 2000 CW, 4000 PEP
Height: 11 Feet
Weight: 10 Pounds
Materials: Anodized 6063 T-6 Aircraft Aluminum Tubing
Requires 2 Separate Coaxial Cables for Hook-up

Call or send \$2.00 for Complete Catalog and Pricing of Antennas.



Route 1 - Box 32C, Hwy. 82
Ethelsville, AL 35461
(205) 658-2229
Hours: 10 am - 6 pm (CST)
Monday - Friday

DEALER INQUIRIES, PLEASE CALL



Selected English Language Broadcasts

Spring 1991

BY GERRY L. DEXTER

Note: There are hundreds of English language broadcasts aired every day on shortwave. This is a representative listing and not intended to be a complete guide. While the listing is as accurate as possible, stations often make changes in their broadcasts hours and/or frequencies, often with little or no advance notice. Some

stations air only part of the transmission in English or may run the English segment into the next hour or more. Some stations have altered schedules on weekends. Numbers in parenthesis indicate a starting time for English that many minutes into the hour. All times are in UTC.

Time	Country/Station	Frequencies	Time	Country/Station	Frequencies	
0000	R. Canada Int'l (M-F)	5960, 9755	0300	Deutsche Welle, Germany	6085, 6120, 9545, 9605	
	BRT, Belgium (30)	9925, 13675		R. Netherlands(30)	9590, 11720	
	R. Luxembourg	6090, 15350		V of Greece (40)	9395, 9420, 11645	
	R. Havana Cuba	11820		R. Tirana, Albania (30)	9760, 11825	
	R. Budapest, Hungary (30)	6110, 9520, 9585, 9835, 11910, 15160		R. Luxembourg	15350	
	R. Beijing	15100, 17705		R. Beijing	9690, 11715, 15100	
	R. Pyongyang, N. Korea	11975, 13775, 15115		TWR, Bonaire	9535	
	R. Yugoslavia	5980, 6035, 11735		R. Sweden (30)	9695, 11705	
	Spanish National Radio	9630, 11880		R. Yerevan, Armenian SSR (50)	7400, 9765, 15180, 15455, 17685	
	HCJB, Ecuador	11775, 15155		Vatican Radio (10)	9635	
	Vatican Radio (50)	6150, 9605, 11780		Kenya Bc Corp	4935	
	R. Sofia, Bulgaria	11660, 15330		R. Prague Int'l	5930, 7345, 11680	
	R. Prague International	7345, 11680, 11990		R. Moscow	9530, 9600, 11710, 11730, 11750, 11980	
	Kol Israel	9435, 11605, 12077				
	R. Kiev, Ukraine SSR	11675, 11790, 12000, 15180, 17665, 17690				
	R. Netherlands (30)	6020, 6165, 15560				
	0100	Deutsche Welle, Germany		6040, 6085, 6145, 9565, 11865	0400	TWR Swaziland (30)
RAE, Argentina		11710	R. Beijing	11685, 11840		
R. Baghdad		11830	R. RSA, S. Africa	7270, 11900		
(Sat/Sun) R. Norway		9615, 11925	V of Turkey	9445		
R. Austria Int'l (30)		9870, 9875, 13730	Swiss Radio Int'l	6135, 9650, 12035		
RAI, Italy		9575, 11800	R. Sofia, Bulgaria	11720, 11735, 15290, 17825, 17835		
R. Japan		5960, 17810, 17835, 17845	R. Prague Int'l	5930, 7345, 11680		
Voice of America		5995, 6130, 9455, 9775, 9815, 11580, 15205	R. Romania Int'l	5990, 9510, 9570, 11830, 11940, 15380		
R. Moscow		11710, 11730, 11930, 17570, 17850, 17860, 17890, 21690				
Voice of Greece		9395, 9420, 11645				
0200		R. Tirana, Albania	9760, 11825	0500		Deutsche Welle, Germany
	R. Cairo, Egypt	9475, 9675	R. Austria Int'l		6015, 6155, 13730, 15410, 21490	
	R. Portugal (30 M-F)	9600, 9680, 9705, 11840	HCJB, Ecuador		11775, 15155	
	R. Havana Cuba	9505, 11820	R. Beijing		11840	
	R. Budapest, Hungary	9520, 9585, 9835, 11910, 15160	Kol Israel		9435, 11605, 11655, 15640, 17575	
	(30-T/W/F/Sat)		V of Nigeria		7255	
	R. Norway (Sat/Sun)	9615, 11715				
	R. Sweden	9695, 11705				
	Swiss R. Int'l	6095, 6135, 9650, 12035, 17730	0600		R. Tirana, Albania (30)	7205, 9500
	Kol Israel	9435, 11605, 12077			R. Havana Cuba	11835
	R. Romania Int'l	5990, 9510, 9570, 11830, 11940, 15380			WCSN	11705
	V of Free China, Taiwan	5950, 9680, 9765, 11740, 11860			Swiss Radio Int'l	15430, 17570, 21770
	BBC	5975, 6175, 7325, 9915, 12095			R. Korea, S. Korea	7275, 9570, 11830
					R. Polonia, Poland	7270, 9675
		R. New Zealand		9855		
		0700		HCJB, Ecuador	9610, 9745, 11835, 11925, 15270	
				TWR, Monaco (40)	9480	
				Swiss Radio Int'l (30)	9560, 13685, 17670, 21695	
				Vatican Radio (30)	6248, 9645, 11740	
				Solomon Is. Bcstng Corp	9545	

Time	Country/Station	Frequencies	Time	Country/Station	Frequencies
0800	KNLS, Alaska KTWR, Guam WSHB R. Austria Int'l (30) R. Australia	7365 15200 13760 6155, 13730, 15450, 21490 9580, 15160, 15240, 15320, 17630, 17750	1600	UAE Radio, UAE R. Portugal (M-F) R. Peach & Progress, USSR (30) V of Vietnam VSDA, Guam R. Pakistan R. Baghdad/V of Peace HCJB, Ecuador (30) R. France Int'l BSKSA, Saudi Arabia	11795, 15320, 15435, 21605 21530 6005, 7325, 9715, 15480 9840, 12020, 15010 11980 13665, 15505, 17555, 21530 11860, 21675 21480 6175, 11705, 12015, 15360, 17620, 17795, 17850 9705, 9720
0900	R. Afghanistan (30) R. Beijing Radio Japan R. Australia	4940, 9635, 17655 11755, 15440 11840, 15270, 17890 9580, 11880, 15160, 15240	1700	WRNO R. Austria Int'l (30) R. RSA, S. Africa Vatican Radio (30) R. Pakistan Voice of America	15420 5945, 6155, 13730 7230, 15270, 17790 17710, 17730, 21650 11570, 15605 9700, 9760, 15205, 15300, 17885, 21540, 21510
1000	V of Vietnam WSHB TWR, Bonaire Swiss Radio Int'l KSDA, Guam All India Radio KHBI, Saipan	9755, 12035 9495 11815, 15345 9560, 13685, 17670, 21695 13720 15050, 15335, 17387 9530, 13675	1800	RFPI, Costa Rica Radiobras, Brazil R. Moscow R. Afghanistan (30) RAE, Argentina R. Havana Cuba R. Yugoslavia (30) All India Radio	13630, 21565 15265 11840, 151785, 17570, 17585, 21685 9635, 9665, 11755 15345 17710 7215, 9660, 11735 11935, 15360
1100	Voice of Vietnam Radiobras, Brazil R. Jordan R. Korea, S. Korea R. Pyongyang, N. Korea R. Austria Int'l (30) HCJB, Ecuador (30) R. RSA, S. Africa VOIRI, Iran	9755, 12035 11745 13655 15575 9645, 9977, 11735 6155, 13730, 21490 11740 9555, 11805, 11900, 17835 9575, 9705, 11715, 11790	1900	R. Canada Int'l (M-F) Spanish National R. R. Austria Int'l (30) HCJB, Ecuador VOIRI, Iran (30) All India Radio RAE, Argentina	13670, 15260, 17820 9875, 11790, 15375, 15395 5945, 6155, 12010, 13730 15270, 17790, 21470 9022, 11895 11620 15345
1200	R. Bangladesh (30) R. France Int'l (30) R. Ulan Bator, Mongolia R. Norway, (Sat/Sun) R. Beijing Voice of Greece R. Yugoslavia R. Tashkent, Uzbek SSR R. Finland AWR, Costa Rica R. Polonia, Poland (30) R. Korea, S. Korea	15195, 17815 9805, 11670, 15155, 15195, 17650, 21635, 21645 11850, 12015 21735, 25730 17855 15635, 15650, 17535 17740, 21555, 25795 7325, 9600, 9715, 11860, 15470 15400, 21550 9725, 11870 9525, 11840, 15120 9570	2000	RFPI, Costa Rica R. Baghdad/V of Peace R. Portugal (M-F) WCSN Voice of America Kol Israel	13630, 21565 11860 11740 13770 9510, 15410, 15580, 17800, 21485, 21625 11605, 12077, 15640, 17630
1300	R. Canada Int'l (M-F) R. Peace & Progress, USSR Voice of Vietnam (30) British Forces Bc Service (30) R. Beijing R. Finland R. Jordan (20) R. Pyongyang, N. Korea Voice of Turkey (30) R. Tashkent, Uzbek SSR (30)	9635, 11855, 17820 7195, 7380 (30), 9675, 11775, 15535, 15520 (30), 17635, 17840 (30) 9840, 12020, 15010 15390, 17695, 21500 11855 15400, 21550 9560 13650, 15230 17785 7325, 9600, 9715, 11860, 15420	2100	Radio Baghdad/Voice of Peace R. Portugal (M-F) R. Yugoslavia Spanish National R. Swiss Radio Int'l R. Africa, Eq. Guinea R. Damascus, Syria (05)	11860 15250 7215, 9620, 11735, 15105 9875 9885, 12035, 13635, 15525 7189 12085, 15095
1400	R. Ulan Bator, Mongolia (45) R. Austria Int'l (30) R. Finland R. Australia R. Japan R. Korea, S. Korea R. Moscow	9950, 13780 6155, 11780, 13730, 21490 15400, 21550 7240, 9580, 11720, 11880, 11910, 11930, 17630, 21775 11815, 11865 9570 11840, 15460, 15540, 17505, 17810, 17830, 21685	2200	R. Vilnius, Lithuania SSR (30) BRT, Belgium UAE Radio, UAE R. Tirana, Albania (30) R. New Zealand (05) BBC V of Free China, Taiwan R. Sofia, Bulgaria (30) R. Moscow	6100, 9675 5910, 9925, 15515 6170, 9600, 15100 7215, 9480 17675 5975, 6175, 7325, 9590, 9915, 12095 9852, 11805 11660, 15330 9610, 11710, 11730, 11840, 11930, 12060, 15355, 15560
1500	KNLS, Alaska KTWR, Guam R. Australia (30) R. Sweden (30) R. RSA, S. Africa R. Beijing V of Greece (30)	7355 11650 9710, 13745 17880, 21500 7230, 15270 11815, 15165 11645, 15625, 17535	2300	R. Canada Int'l R. Vilnius, Lithuania SSR UAE Radio, UAE RFPI, Costa Rica (30) Voice of Vietnam (30) R. Pyongyang, N. Korea V of Turkey R. Japan	9755, 11730 6100, 11675, 11790, 15180, 17665, 17690 6170, 9600, 13605, 15100 7375USB, 13630, 21565 9840, 12020, 15010 11735, 13650 9445, 9665 11835, 15195, 15210, 17810, 21610



Military operations in the Mideast have a high interest at present. Many of these comms can be monitored here in North America by scanner owners. (US Army photo.)

Zeroing In On Worldwide Scanner Skip

**Mysterious Military "Lists" Stations, Desert Storm,
Even Pirates – Hear 'em on Your Scanner!**

BY CHUCK ROBERTSON

The 1990/91 F-2 skip season looks like it's going into the books as one of the best, and it's not yet over! My own log book is bulging with DX loggings in the 30 to 50 MHz VHF "low band," and I'm hearing from others who have had similar results. But April is usually the last truly great DX month for long haul F-2 skip in the 30 to 50 MHz band, so now's the time to get in your licks.

Short-hop Sporadic-E skip will be on the increase in April, peaking in mid-summer. So, you won't be shut-out altogether.

Desert Signals

Signals from the Middle East are heading towards North America like they're propelled by an Arabian sand storm. If you listen around, you can hear American military

operations on dozens on 30 to 50 MHz channels. On 32.05, for instance, one GI was advising, "I'm leaving Truba." This is a location in Saudi Arabia, near the Iraqi border.

More DESLO (desert location) comms were on 30.50 MHz: "The M3 section is dug-in without overhead protection." Helos and air/air comms are noted on 32.15 MHz, 34.00, 34.20, and 41.80 MHz. Port

ops unloading military equipment have been logged on 32.50 MHz. VIP visits are coordinated on 41.80 MHz.

Of course, military forces are from many nations. Some Arabic is noted mixed in with American nets. On 33.75 MHz, *Echo 1* demanded, "You'll have to speak English, we are unable to understand your traffic." On 37.40 MHz, I've logged joint Saudi and U.S. ops, and some channels produce French language mil comms.

Live-ammunition artillery practice turns up on 33.30 MHz. Plenty of other active U.S. mil nets, too. Try: 30.65, 31.80, 32.25, 32.40, 32.70, 33.90, 35.00, 36.60, 38.05, 38.10, 38.95, 39.10, 39.20, and 39.30 MHz.

There's more going on in the volatile Middle East than Desert Storm. An Israeli base repeater on 34.20 MHz ID's as "Jerusalem." Other Israeli repeaters are being logged on 34.02, 34.40, 37.00, and 38.00 MHz. These might be military police.

A Cypriot police repeater, using both Greek and English, is being noted on 33.40 MHz.

A radiophone on 30.785 MHz uses an Arabic language for its base frequency. Beirut is mentioned in some of the calls.

Special thanks to Max van Arnham, of The Netherlands, also to Mark Knowlton, Palm Bay, FL, and his "Professional Monitoring Team" for their timely and valuable information on monitoring the Middle East. This is a popular target area for monitoring.

Hide 'N Seek Sigs

In the July, '90 *POP'COMM*, I reported hearing UK naval vessels in port at Halifax, Nova Scotia. As I had mentioned, their busy maintenance net on 34.30 MHz was a good barometer of band openings, and this frequency has long been reliable for such purposes.

After the July issue appeared, I began noticing something irregular about the time of day these signals were coming through. I used to hear them during summer evenings via Sporadic-E skip. But reception had changed to winter days via long-hop F-2 skip. This would indicate that the vessels were moving!

Then it happened. The band blossomed out with UK wargame comms on 30.10, 30.50, 31.00, 31.10, 31.30, 31.50, 32.20, 32.50, 32.60, 32.80, 33.00, 34.10, 36.10, and 36.80 MHz. The 34.30 MHz maintenance channel was also busy.

Where were these wargames taking place? The comms I heard indicated that some participants were on land. Were they on an island in the West Indies? Eventually, I picked up on a few place names, like Stanley, and Lively Island. That would seem to place the area of operations in the area of the Falkland Islands.

Other scanner DX fans contacted me to report hearing UK military activity. Russell Write, Houston, TX heard them regularly

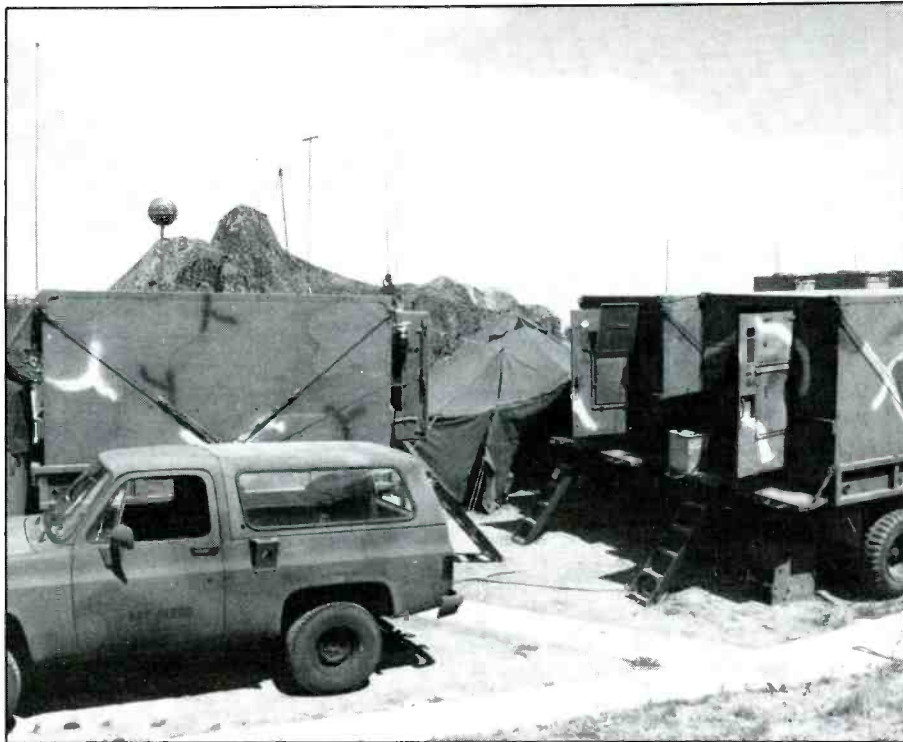

The sky above, the sand below! What with so many military forces deployed to the Mideast, there is an abundance of comms traffic going out. See text for some choice frequencies presently skipping into North America. (US Army photo by Sgt. Robert L. Reeve, US Army Combat Pict. Det.)

on 34.30 and 34.90 MHz. They seem to use channels spaced at 100 kHz intervals.

To check if skip is coming in from South America, listen for *Radio Advise* (Radio Advise), a 100 watt paging station on 31.35 MHz in Montevideo, Uruguay. This Spanish language station is heard around the world when the band opens up. Joop Prosee, of Spanbroek, The Netherlands, regularly copies this one (and another on 35.08 MHz) from mid-morning to evening. In North America, look for it throughout the daylight hours, although I've even copied it as late as 11 p.m.

Bearmeat

Skip reception often brings me scanner reception (here in Illinois) of low-band comms at the huge Twentynine Palms USMC Air Ground Combat Center, in California. This facility conducts infantry, artillery, and armored combat operations to evaluate the USMC's capabilities against a Soviet-type threat. Appropriately, the base ID's as *Bearmeat*!

One of the channels I recently discovered there is 30.30 MHz, called Control 2. It seems to be a top brass net used for Command Operations, as in: "Tell that long-winded major to get out here on the range!" Interestingly, 30.30 MHz is also used at nearby Ft. Irwin NTC for similar purposes.

Range Control and live fire ops are being heard on 32.85, 33.00, and 48.85 MHz. You hear things like, "First Marines, this is

PC SWL \$99.00

A Complete Digital Reception System

PC SWL contains the hardware, software, instructions and frequency lists needed to allow you to receive a vast variety of digital broadcasts transmitted over shortwave radio with any IBM PC or Compatible computer. The product consists of:

**Demodulator
Digital Signal Processing Software
80 Page Tutorial Reference Manual
World Press Frequency List
Tutorial Audio Cassette with Samples**

PC SWL automatically decodes Morse code, Radio Teletype, FEC (forward Error Correcting Code), SELCAL (Selective calling transmissions), and NAVTEX.

ADVANCED FEATURES:

Tuning Oscilloscope
Digital Waveform Presentation
Auto Calibration and Code Recognition
Continuously Tunable Filter Frequencies
Variable Shift
Adjustable CW Filter Sensitivity
Farnsworth Code Compatibility
Unattended Capture and Printing

**Software Systems Consulting
150 Avendia Cabrillo "C"
San Clemente, CA 92672
(714) 498-5784**

CIRCLE 14 ON READER SERVICE CARD

Spring '91 Skip Scanning Log

Abbreviations: SS= Spanish; EE= English; FF= French; BI= Business; TD= Time Division Multiplex; MUX= Multiplexing. Unless otherwise noted, all mil listings are Wide Band FM (WFM); others listings are Narrow Band FM (NFM).

29.725, 29.755: SS radiophones.
29.745, 29.755: Simplex radiophones, Arabic.
29.75: Canadian trawlers with bootleg comms. One station uses TD scrambler, the other replies in clear voice. ID is "Bald Point," British Columbia.
29.80, 29.82: FF from France. Sounded like outbander chit-chat.
29.80: American outbanders, AM-mode. Lots of profanity.
29.85: SS radiophone.
29.90: Tones, AM-mode, probably paging. Also 29.80 & 29.82 MHz.
30.00: "Recon, we have 2 missiles coming down." US mil. Also Stations Papa 40 & Papa 54 at Ft. Ord, CA.
30.10, 30.30, 30.40: Voice & non-voice paging. Scandanavia.
30.145, 30.30, 30.855: SS radiophones.
30.175: A station with Greek t/c.
30.19: Soviet mil, TD net.
30.20, 31.10, 32.95, 34.10: FF military t/c.
30.25: "Eagle 3 at Bike Lake." Ft. Irwin NTC, CA.
30.265, 30.31, 30.345, 30.405, 30.445, 30.51, 30.585, 30.595: Radiophones, Arabic.
30.30: "854, this is warship Halifax." Also USN: "Kilo, this is Imperfect." Heard here, too, was Zero Bravo (base) with, "Be advised, this is the Bearmeat frequency." Bearmeat is USMC at Twentynine Palms, CA.
30.45: US mil "Rappel Master" & "Mike 49"-- "I've got to call a guy in San Diego."
30.50: Security at US Embassy in UK, NFM mode, "Which Romeo did you pick up?"
30.55: SS radiophone at Cancun, Mexico.
30.645, 30.665, 30.815, 30.965: Radiophones, Arabic.
30.65: Maneuvers at Ft. Irwin, CA. This was the Command Net. ID's included: Spear 3, Task Force 142, 03 Oscar, 03 Steel, Bayonet 03, Tarantula, 0 Top Drawer. "Troops will attack at 1700 hours. Be prepared to counterattack objective Lewis and Clark."
30.695: Radiophone in UK.
31.00: Ft. Irwin NTC, CA: "Good shot! You caught one in the sleeping bag."
31.02: NY City "gypsy cabs" on bootleg channel, in SS. Many NYC locations mentioned-- LaGuardia, Washington Bridge, etc.
31.04: NY City "gypsy cabs" on legit freq, in Arabic.
31.06, 31.08, 31.12, 32.00, 33.00, 33.14, 35.00, 35.36, 43.70: NY City "gypsy cabs, bootleg frequency, in SS, mentioning Yonkers, Richmond Plaza, etc.
31.15: FF t/c from France.
31.20, 32.35, 32.45, 33.85: Mil t/c in Arabic.
31.37: Canadian trawlers, bootleg freq, Old House Bay, west coast.
31.375: UK mil, probably inside UK. Heard early morning. NFM mode: "Time of flight, 31 mikes." Base ID was "Shot."

31.38: Canadian trawlers, bootleg freq, Cartwright Bay, BC.
31.40: An oil driller somewhere in US southwest complaining, "Ain't got many people to party with out here in this desert."
31.48: Ship-to-ship comms, Japanese. Heard evening hours, so ships might well have been in Japanese waters. This is the very active Gulf Fleet Marine Co. (Louisiana) comms freq which I always keep running in my scanner. Also listen on HF 4143 kHz USB.
31.50: UK mil, Falkland Islands.
31.55: Command channel for maneuvers. Possibly Ft. Irwin NTC, CA. ID was "Iron Eagle."
31.59: Canadian trawlers bootlegging. Speech inversion scramblers.
31.60: US mil: 18-Alpha calling Zero Purse String.
31.65: US mil: Tiger Talk calling Headquarters 68.
31.70: Turkish t/c.
31.85: US mil, DES scrambling.
31.85: Ft. Irwin NTC with message about aircraft returning to Nike Lake. ID's were Eagle 02 & Eagle 03 Tango.
31.90: US mil "Bay Center Talk."
31.925: Ditch mil "Zero Alpha."
31.95: FF, maybe French Guiana, with unstable tone before each xmsn. Also horse racing bookies from Jamaica here, plus on 32.10, 32.30, 32.55, 36.875/33.875, 45.525, & 45.80 MHz.
31.975: EE from RSA, possibly fishing trawlers.
32.02: Argonne Nat'l. Labs, Lemont, IL. This is Channel 1.
32.05: German, French, Arabic speaking mil. Also US mil Desert Shield live fire artillery practice ops, "A, this is Six Shot."
32.0875, 32.2875, 32.3625, 32.6125, 32.75, 32.8625, 32.925, 32.95: Soviet mil, TD nets.
32.10: Repeater (32.70 in) with EE & Afrikaans from RSA. May be mining related. Look for others: 32.05 32.15 32.20 32.25 & 32.30 MHz. Also US comms from S3-Alpha, "Bubblemug 22 got messed up trying to save everybody." While towing a ship into San Francisco harbor, a tug lost an engine and caused a 4-vessel accident. See 36.15 MHz.
32.15: US a/c discussing undersea volcanic activity in the area below them, saying when it comes to life it blows water several hundred feet into the air.
32.30: US mil "Sunray Miner."
32.35: USN net. ID's of Orange Catskill, Green Catskill, 4 Orange 2, Red Catskill, Blue Catskill, Romeo One Half. Any more info? Also another US mil ID as Mother Load & Mother Load 1.
32.45: Air/air at Ft. Irwin NTC. This is also Bike Lake Metro freq, secondary is 49.05. Weather Teams & Metro on 32.20 MHz.
32.50: US mil convoy from Ft. Ord to Ft. Irwin NTC, CA.
32.70: Control 30 & Range 10, US mil stations in western state.
32.75: US mil tank/tank comms, 003, 006, 007, "Fire main gun...near miss." Another US mil here was Bradfree calling ADTB Mobile. Mentioned 347.0 MHz.
32.80: Probably US mil in Fairford, UK. Was NFM mode. Confirmed an ambulance was dispatched.
32.90: USN FACSFAC in CA, "Give Beaver a call." Also 32.10 & 34.85 MHz.
33.00: US mil stations Jughead & Delta 19.
33.04: Radiophone, Arabic.
33.05: Israeli mil net, in Hebrew.

Bearmeat. The Medevac bird is down." Some of the other ID's on these frequencies include: Noble Pass, Blacktop, Range 410, Chapel Mobile, Retrans, Zero Bravo, CP (Command Post), Joker 22, 7-Victor, Charlie 4 Delta, Charlie 8 Oscar, also Vis-mod, which means equipment that has been visually modified to look like enemy equipment.

Word Games

Plenty of military mystery in this band, too. For example, I've long been puzzled by long monosyllabic word lists intercepted on 34.30 MHz with, "Would you write (word) now?" This short sentence is repeated over and over with the blank space filled in with a different word each time. "Would you write *claus* now?" "Would you write *sash* now?" "Would you write *thorn* now?"

Each time I heard this, simultaneously on 36.90 MHz there are long phonetic lists. An example: "Blue Bird 19, message number seven to follow. Tango, Oscar, Sierra, Uniform, Alpha, Yankee, Tango, Kilo . . ."

Obviously military, my guess is that they may be AWACS radar intercept messages. Similar cryptic comms have been observed in the UHF aero band. Anybody have more information?

Alphanumeric Antics

What about that unusual station transmitting three letter phonetic groups? Though most active on 34.94 and 34.975 MHz, these transmissions are also being logged on 30.10, 34.91, and 34.95 MHz. It's all from the same station, but the frequency used changes from day to day.

You hear things like: "Alpha-Tango-Charlie, Sierra-Romeo-Delta, Foxtrot-Bravo-Golf, etc." The overall phonetic sequence is about thirty seconds long, and keeps repeating until the station abruptly shuts down. A few minutes later, the station comes back on again with new phonetics. The phonetics are produced by an automated male voice.

Meanwhile, an automated female voice pours out long lists of numbers (sequence repeated every thirty seconds) on 30.10, 40.05, and 40.45 MHz.

Are these training exercises, or what? What are they training for? Who are they? Where are they? If you have some answers, let me know. Just write to me in care of POP'COMM.

Pirates, Ahoy!

Tracking down outlaw comms stations in this band is always an enjoyable challenge.

One also wonders who and where they are, and what businesses they conduct. And how/why did they select the particular frequencies they picked to use?

Over the years, I heard drug smugglers and dealers, bootleg radiophones, surveillance operations, fishing trawlers, taxis, and other unlicensed two-way comms between 30 and 50 MHz. There's something uniquely fascinating about tuning in such activities. Amazingly, few seem to ever get caught by the FCC.

Recently, my scanner locked onto 34.95 MHz, a frequency reserved for U.S. Government comms. A base dispatcher asked one of the drivers to meet him at a particular fast food place for lunch. The mobile unit came back and said, "No, I have to hit the streets for drugs, OK?" Was he joking? I didn't think so.

After monitoring this pirate for a few days, it turned out that it was a wrecker located in the heart of Los Angeles!

Another interesting unauthorized operation is the electric utility company in Florida that boldly uses 37.26 MHz, which is allocated for police use only. There's a marina in the Ft. Lauderdale area operating on 47.65 MHz, which isn't allocated to any radio service in the USA. Another station on

33.175, 33.25, 33.575, 33.60, 33.775, 33.80, 33.825: Soviet mil, TD nets.
 33.20, 33.70: Hebrew tfc.
 33.25: US mil discussing parachute jump for next day.
 33.40: Ft. Irwin NTC, Control 2 channel with maneuvers. ID's: Horseman 34, Portable 34.
 33.46, 33.48, 33.50: Portuguese from Brazil. Lots of these stations here in 20 kHz steps. See 39.90 MHz listing.
 33.475: Repeater (39.475 in), "Mia Control." Cent. America, SS.
 33.60: Repeater out (37.125 in), Cuba.
 33.80: Possibly Ft. Irwin NTC. Scouts observing OPFOR movements.
 33.95: Ft. Irwin NTC, maneuvers here & on 32.30 MHz. ID as Firebox 74, "Proceed to Phase Line Leningrad."
 34.00: US mil stations Titan 1 & Titan 2.
 34.025: Repeater in (37.025 out), Jamaica. Also here & 34.05 noted Dutch or Afrikaans tfc.
 34.10: US mil, NFM, possibly in UK: "We have an explosion in the battery house. One casualty."
 34.10: Dutch or Afrikaans tfc. Also a repeater out in Hebrew ID'ing as "Jerusalem."-Also try" 34.02, 34.40, 37.00, 38.00, 38.20.
 34.35: SS mil, some EE, maybe Centr. Amer.: "This is Captain Santiago. I need you to stop the convoy."
 34.50: Ft. Irwin NTC net. ID's: Scorpion Base, Lizardland, Helipad 6, Duce, One Half, 3 Tango, 87th Maintenance. May be called Channel 3. "I'm waiting for the pilot to land at Bike Lake."
 34.60: Ft. Lewis, WA with ID as Bullseye. Airspace control.
 34.625: Turkish repeater out. Many others between 34 & 34.80 MHz, 25 kHz spacing. Some repeat German & FF input freqs.
 34.65: US mil Middle East control tower. Another US mil here ID'd as Romeo 30 said, "No forklift today. It's harge day."
 35.00: Maybe Ft. Irwin NTC net. ID's: Hot Air Talk, Duce, One Half, One Half, Mike Alpha 1. "Can you guard the prisoners?" Also FF mil in Saudi Arabia.
 34.85: USCG tactical air/boat comms in FL. Very hot! Also USN ops in San Francisco area with vessels ID'ing as Tac 1, Tac 2, and Kansas City.
 34.90: US mil net, Ft. Ord., CA, "I'm trying not to put a panic into the system, but the aircraft have been filled with mo-gas instead of JP4." Other ID's: X-77, Camp Roberts, Liggett.
 34.95: US mil repeater, "Set up visitors' site."
 35.00: Repeater out rebroadcasts US police skip.
 35.04: An itinerant business channel like this (& 43.04) often turns up odd stuff: "Surfside to Ollie. There's a subject refusing to leave."
 35.35, 35.50, 36.00, 39.05, 39.20, 39.80, 39.95: Hebrew tfc.
 35.74: German chit-chat. Also a Turkish station.
 35.725: Brazilian pager, AM mode, in Portuguese. More of these in 25 kHz steps from 35.50 to 35.975 MHz.
 36.095, 36.26, 37.75: Italian stations.
 36.12, 36.14, 36.16, 39.10, 39.60, 39.70, 40.00: German stations.
 36.15: US mil, ID's: Green Boat & Oarfish 547. "We have casualties. Send MASH 1627 to the beach."
 36.1625: Police & Transportation stations in FF, from France. More from 34.90 to 36.20 in 12.5 kHz steps.

36.50: Skaggs Isl., CA, USN Security. ID's: Silver Lobster, Chamber Skill (base), Delta 1 (patrol boat). Ft. Ord, CA may also be on this freq.
 36.60: US Army Med Center, Presidio of San Francisco. Chem unit a/c were departing.
 36.65, 37.15: German mil.
 36.70: US mil maneuvers, maybe Middle East. ID's Radio 36, ASP Guard. "Black Devil 31. That's a booby trap."
 36.74: US mil, maybe Europe. Airport ground vehicles.
 36.90: US mil a/c ID'd as Big Daddy 239. Also maneuvers, "Move out! Blue 1, stay with your wing man."
 36.92: Dispatcher in NY city on pirated freq, in SS. Also try 36.04.
 36.95: Ft. Irwin NTC net with ID's: Control 1, Scorpion 19, Tarantula 20, Bronco 7, Spear 3.
 37.10: US mil in mideast, Guard Channel Alpha.
 37.20: Jamaican repeater (34.20 in). "Friendship Farm" shopping center, Ocho Rios.
 37.30: SS mil net. ID's are Oro & Pino.
 37.40: Egyptian mil.
 37.60: Repeater out (31.04 in), maybe Brazil. Repeats UK skip early morning, then US business skip later in day.
 37.70: RSA Police, Pretoria area. ID's: Kilo Control, Kilo 2.
 37.80: Ft. Irwin NTC, ID's: Outlaw, Dragon 2.
 37.95, 38.90, 39.95: SS mil, TD scrambling.
 38.00: Turkish tfc. Also Soviet mil.
 38.025: RSA Police, active. Also try 38.075, 38.10, 38.125, 38.20.
 38.30: Range Control in Hawaii. Could be USN at Wheeler AFB.
 38.54, 38.56: Repeater out, German police or ambulance.
 38.65, 38.675, 38.75: Pakistan, maybe police.
 38.70: US mil, ID's were Bravo 60 & Tabletop. "We have movement outside the perimeter."
 38.725: Soviet repeater out.
 38.90: Range Control, Camp Roberts, CA.
 39.00: US mil ID's: Bookcase Lima, Chord 9'er. Also FF, simplex.
 39.10: Farsi tfc, presumed from Iran.
 39.225: FF repeaters, France. Check 39.225 to 39.725 (12.5 kHz).
 39.25: SS mil, ID as Delta Whiskey.
 39.275: Repeater out, rebroadcasts Soviet skip.
 39.30: SS mil, Tegucigalpa, Honduras. Also 39.95.
 39.65: Ft. Irwin NTC, Command Frequency. ID's: Delta-33 & -88.
 39.75: US mil a/c ops. ID's: South Tower & Tower 02.
 39.90: Repeater out (33.22 in) from Brazil.
 40.30: USN vessels at spill site.
 42.00: Repeater out, in SS. May be Colombian.
 43.15: Radio Netherlands STL.
 45.80: Soviet mil.
 46.10: Radiophones in Israel. Lots of these 42 to 48 MHz.
 46.60: Police base & patrols. Possibly Cartagena, Colombia.
 47.00: Illinois Air Guard practicing earthquake Medevac ops.
 48.70: SS, may be police in Cali, Colombia.
 48.70: US mil, the "Adam Net." Could be USMC Twentynine Palms, CA observer or command net. Any ideas?
 56.65: Ft. Irwin NTC. "I've got information of use to Tarantula 07's AAR." AAR means After Action Review.

an unallocated frequency uses 30.12 MHz, and appears to be in New Jersey. A frequency of equally unauthorized status, 48.07 MHz, is used by "Melrose Base." This station seems to operate in connection with the towing and repair of large trucks and operates in Rhode Island and eastern Massachusetts.

I hear a lumber yard and hardware supply activity somewhere running its operations on 31.12 MHz, which is a transportation frequency.

The urban transit channel 31.08 MHz accommodates a company doing construction work. I think it might be in Louisiana. Don't confuse it with the pipelaying company in Alberta on this frequency.

And let's not forget the infamous New York City "gypsy cabs" that operate throughout the band on all sorts of weird frequencies. Often using Spanish and Asian languages, they not only don't have FCC licenses, often they don't even have taxi licenses. Check out the accompanying list for some of their current frequencies, as well as other skip scanning delights from near and far.

All of these stations, and more, await those who tune the 30 to 50 MHz scanner band.

SUBSCRIBE NOW & SAVE!

ASSOCIATED RADIO

8012 CONSER BOX 4327
OVERLAND PARK, KANSAS 66204

CALL 913-381-5900

FAX 913-648-3020

**SHORT WAVE
AMATEUR
RADIO**

New and reconditioned equipment.
BUY—SELL—TRADE—SERVICE



**CALL FOR
YOUR
LISTENING
NEEDS**

Send \$3.00 for our current catalog and wholesale sheet.

Please send all reader inquiries directly.

How Do You Hear Them?

Many of you have, no doubt, browsed the pages of Satellite View in the past, and assumed that listening to satellite and other exotic space communications required outrageously expensive pieces of radio gear and extraordinary radio skills. So you moved on to read about other, more practical, radio pursuits. Both ideas are myths, however.

It's much easier to DX the Final Frontier than you may have thought. In fact, if you own a scanner which will receive frequencies between 118 and 174 MHz, you are already equipped to hear voice communications from the US Space Shuttle and the Soviet Space Station Mir. Both spacecraft are equipped with FM Amateur Radio gear that operates on two (possibly more) voice frequencies in the 143 MHz range. These transmissions are wide-band FM.

There are several new Amateur Radio satellites in orbit. One easily heard spacecraft is called DOVE (Digital Orbiting Voice Equipped). This low altitude spacecraft transmits telemetry in voice mode (FM) using a voice synthesizer on frequency of 145.825 MHz. Three additional satellites (Oscar 14, 15 & 16) can be heard transmitting on the satellite band that runs between 435 and 437 MHz. These Amateur satellites use the Packet (digital) mode of operation. This, of course, does take additional equipment but it is still affordable if you shop wisely.

The USSR has a fleet of Amateur Radio satellites which transmit (downlink) in the 10 meter band between 29.357 and 29.453 MHz. If your Shortwave receiver has a BFO or a SSB position on the mode switch you will be able to hear Amateur Radio satellite communications whenever a Soviet spacecraft is within range of your station. American and Japanese satellites also use SSB downlinks on 453 MHz. If you are interested in data communications from satellites you will need additional equipment. For example, if you are interested in listening to the Packet satellites or working other stations, if you are a licensed Amateur operator, you will need a computer, a TNC, a PSK modem and software. As you can see in the diagram below the antenna and tracking requirements for Packet satellites is considerably simpler than those required of a OSCAR 13 station.

Until now, the only way to get a multi-mode ground station that could receive SSB and data was to buy an ICOM R7000 or a Multi-mode single band Amateur Radio transceiver. For this reason the R7000 has become somewhat of a standard by which other receivers were judged. Until now,



The SC-one is an affordable SCPC receiver produced by Heil Sound.

there has not been much competition. You may recall that well over two years ago I predicted we would soon see a whole new class of receiver hit the market; receivers of unusually small size that would truly be wide-band multi-mode miracles. Ace Communications of Indianapolis, Indiana was the first company to market ultra-wide-band multi-mode scanning receivers. They marketed their first scanner, the AR2002, in 1986.

Ace has also broken a price barrier with the introduction of the AR2500. This radio tunes from 1 MHz to 1500 MHz (1.5 GHz). It operates in the AM, FM, Wideband FM, SSB and CW modes. It has a selectable bandwidth of 5, 12.5 and 30 KHz. It can scan 62 memory banks of 32 frequencies each. An additional 16 memory banks are dedicated to setting the beginning and ending frequency when searching for new stations. The AR2500 can also be controlled and programmed from the keyboard of any computer through the built-in RS-232 interface. All of this in a package that measures 2 1/4" high, 5 5/8" wide and 6 1/2" deep. Its older brother, the AR3000 has similar cov-

erage and operates all modes. In addition, it will display and analyze any transmission it receives, on either a computer monitor or on a dot matrix or laser printer. The Ace AR950 is a more "standard" scanner. It operates AM, FM, WFM and covers the low, Air, high, UHF and unrestricted 800 MHz band. These receivers will let you listen to any of the Amateur satellites and manned space frequencies, in addition to all of your favorite shortwave broadcasters, police, fire and other public service stations.

Another area of affordable listening these days, if you are not already equipped, is TVRO (TV Receive Only station). Satellite TV receivers and antennas are readily available on the used markets. In fact, you can pick-up a good receiver for \$50 and I have known people to pick-up a dish antenna for simply removing it from the property. You can often find a cheap dish antenna new for approximately \$100. About the only thing on the satellites that is not scrambled these days is sports, religion and those damnable shopping channels.

Well, I guess I've given you at least two good reasons not to get into TVRO. There are, however, several audio services (non-video) carried by TV satellites. These fall into two categories: Audio subcarrier, which is attached to the main video signal, but separate from the video programs audio; and the second is what is called SCPC or Single Channel Per Carrier. The audio that is attached to a video program is usually found at 6.2 or 6.8 MHz. This signal is attached to the video signal and is found on most receivers by tuning a manual audio tuning knob or with your remote control. Similarly, any additional audio signals you want to send can be attached in a similar fashion. This allows more efficient use of the transponder fre-



The AR-2500 is an ultra-wide range multi-mode (AM/FM/WFM/SSB/CW) receiver.



AR-3000 offers continuous coverage from .5-1500 MHz.

COMMUNICATIONS ELECTRONICS INC.

Emergency Operations Center has expanded to our new two acre facility and World Headquarters. Because of our growth, CEI is now your one stop source for emergency response equipment. When you have a command, control or communications need, essential emergency supplies can be rushed to you by CEI. As always, for over twenty two years, we're ready, willing and able to help.

Our RELM two-way radio transceivers were especially created for government agencies. When you need to talk to police, fire, ambulance, or state, federal and international response forces, RELM transceivers may be quickly programmed for up to 48 frequencies. Listed below, are some of our most asked about transceivers. For additional assistance, call CEI at 313-996-8888.

NEW! RELM® RSP500-A

List price \$465.00/CE price \$319.95/SPECIAL
20 Channel • 5 Watt • Handheld Transceiver
Frequency range: 148-174 MHz continuous coverage. Will also work 134-148 MHz, with reduced performance. The RELM RSP500B-A is our most popular programmable 5 watt, 20 channel handheld transceiver. You can scan 20 channels at up to 40 channels per second. It includes CTCSS tone and digital coded squelch. Snap on batteries give you plenty of power. Additional features such as time-out timer, busy-channel lockout, cloning, plug-in programming and IBM PC compatibility are standard. It is F.C.C. type accepted for data transmission and D.O.C. approved. We recommend also ordering the BC45 rapid charge 1½ hour desk battery charger for \$99.95, a deluxe leather case LC45 for \$48.95 and an external speaker microphone with clip SM45 for \$59.95. Since this radio is programmed with an external programmer, be sure to also order one PM45 at \$74.95 for your radio system.

NEW! RELM® UC102/UC202

List price \$128.33/CE price \$79.95/SPECIAL
CEI understands that all agencies want excellent communications capability, but most departments are strapped for funds. To help, CEI now offers a special package deal on the RELM UC102 one watt transceiver. You get a UC102 handheld transceiver on 154.5700 MHz., flexible antenna, battery charger and battery pack for only \$79.95. If you want even more power, order the RELM UC202 two watt transceiver for \$114.95.

NEW! RELM® RH256NB-A

List price \$449.95/CE price \$299.95/SPECIAL
12 Channel • 25 Watt Transceiver • Priority Time-out timer • Off Hook Priority Channel
The RELM RH256NB is the updated version of the popular RELM RH256B sixteen-channel VHF land mobile transceiver. The radio technician maintaining your radio system can store up to 16 frequencies without an external programming tool. All radios come with CTCSS tone and scanning capabilities. This transceiver even has a priority function. Be sure to order one set of programming instructions, part # PI256N for \$10.00 and a service manual, part # SMRH256N for \$24.95 for the RH256NB. A 60 Watt VHF 150-162 MHz. version called the RH606B is available for \$429.95. A UHF 15 watt, 16 channel similar version of this radio called the LMU15B-A is also available and covers 450-482 MHz. for only \$339.95. An external programming unit SPM2 for \$49.95 is needed for programming the LMU15B UHF transceiver.

NEW! RELM® LMV2548B-A

List price \$423.33/CE price \$289.95/SPECIAL
48 Channel • 25 Watt Transceiver • Priority
RELM's new LMV2548B gives you up to 48 channels which can be organized into 4 separate scan areas for convenient grouping of channels and improved communications efficiency. With an external programmer, your radio technician can reprogram this radio in minutes with the PM100A programmer for \$99.95 without even opening the transceiver. A similar 16 channel, 60 watt unit called the RMV60B is available for \$489.95. A low band version called the RML60A for 30-43.000 MHz. or the RML60B for 37-50.000 MHz. is also available for \$489.95.

RELM® Programming Tools

If you are the dealer or radio technician maintaining your own radio system, you must order a programming tool to activate various transceivers. The PCKIT010 for \$149.95 is designed to program almost all RELM radios by interconnecting between a MS/DOS PC and the radio. The PM100A for \$99.95 is designed to externally program the RMV60B, RML60A, RML60B and LMV2548 radios. The SPM2 for \$49.95 is for the LMV25B and LMU15B transceivers. The RMP1 for \$49.95 is for the RMU45B transceiver. *Programmers must be used with caution and only by qualified personnel because incorrect programming can cause severe interference and disruption to operating communications systems.*

★★★ Uniden CB Radios ★★★

The Uniden line of Citizens Band Radio transceivers is designed to give you emergency communications at a reasonable price. Uniden CB radios are so reliable they have a two year limited warranty.

PRO310E-A3 Uniden 40 Ch. Portable/Mobile CB \$72.95
PRO330E-A3 Uniden 40 Ch. Remote mount CB \$99.95
GRANT-A3 Uniden 40 channel SSB CB mobile \$152.95
WASHINGTON-A Uniden 40 ch. SSB CB base \$209.95
PC122-A3 Uniden 40 channel SSB CB mobile \$113.95
PC68A-A Uniden 40 channel CB Mobile \$78.95
PRO510X-A3 Uniden 40 channel CB Mobile \$34.95
PRO520X-A3 Uniden 40 channel CB Mobile \$49.95
PRO535E-A Uniden 40 channel CB Mobile \$73.95
PRO538W-A Uniden 40 ch. weather CB Mobile \$78.95
PRO640E-A3 Uniden 40 ch. SSB CB mobile \$133.95
PRO810E-A Uniden 40 channel SSB CB Base \$174.95

★★★ Uniden Radar Detectors ★★★

Buy the finest Uniden radar detectors from CEI today.
CARD-A3 Uniden credit card size radar detector \$127.95
RD3XL-A3 Uniden 3 band radar detector \$124.95
RD99TL-A Uniden "Passport" size radar detector \$89.95
RD9XL-A3 Uniden "micro" size radar detector \$107.95
RD25-A Uniden visor mount radar detector \$54.95

Bearcat® 200XLT-A

List price \$509.95/CE price \$239.95/SPECIAL
12-Band, 200 Channel • 800 MHz. Handheld Search • Limit • Hold • Priority • Lockout
Frequency range: 29-54, 118-174, 406-512, 806-956 MHz. Excludes 823.9875-849.0125 and 868.9875-894.0125 MHz. The Bearcat 200XLT sets a new standard for handheld scanners in performance and dependability. This full featured unit has 200 programmable channels with 10 scanning banks and 12 band coverage. If you want a very similar model without the 800 MHz. band and 100 channels, order the BC 100XLT-A3 for only \$179.95. Includes antenna, carrying case with belt loop, ni-cad battery pack, AC adapter and earphone. Order your scanner now.

Bearcat® 800XLT-A

List price \$549.95/CE price \$239.95/SPECIAL
12-Band, 40 Channel • No-crystal scanner Priority control • Search/Scan • AC/DC
Bands: 29-54, 118-174, 406-512, 806-912 MHz. **Now...nothing excluded in the 806-912 MHz band.** The Uniden 800XLT receives 40 channels in two banks. Scans 15 channels per second. Size 9¼" x 4½" x 12½". If you do not need the 800 MHz. band, a similar model called the BC 210XLT-A is available for \$178.95.

NEW! Uniden® MR8100-A

Call 313-996-8888 for special CEI pricing
12-Band, 100 Channel • Surveillance scanner
Bands: 29-54, 116-174, 406-512, 806-956 MHz. The Uniden MR8100 surveillance scanner is different from all other scanners. Originally designed for intelligence agencies, fire departments and public safety use, this scanner offers a breakthrough of new and enhanced features. Scan speed is almost 100 channels per second. You get four digit readout past the decimal point. Complete coverage of 800 MHz. band when programmed with a personal computer. Alphanumeric designation of channels, separate speaker, backlit LCD display and more. To activate the many unique features of the Uniden MR8100 a computer interface program is available for \$19.95. Due to manufacturers' territorial restrictions, the MR8100 is not available for direct shipment from CEI to CA, OR, WA, NV, ID or UT.

NEW! Ranger® RC12950-A3

List price \$549.95/CE price \$259.95/SPECIAL
10 Meter Mobile Transceiver • Digital VFO Full Band Coverage • All-Mode Operation Backlit liquid crystal display • Repeater Splits RIT • 10 Programmable Memory Positions
Frequency Coverage: 28.0000 MHz. to 29.6999 MHz. The Ranger RC12950 Mobile 10 Meter Transceiver has everything you need for amateur radio communications. The RF power control feature in the RC12950 allows you to adjust the RF output power continuously from 1 watt through a full 25 watts output on USB, LSB and CW modes. You get a noise blander, roger beep, PA mode, mike gain, digital VFO, built-in S/R/MOD/SWR meter. Frequency selections may be made from a switch on the microphone or the front panel. The RC12950 gives you AM, FM, USB, LSB or CW operation. For technical info, call Ranger at 619-259-0287.



RELM
LMV2548B
Only \$289.95

OTHER RADIOS AND ACCESSORIES

XC385-A Uniden Ultra Clear Plus Cordless Phone \$89.95
CT785S-A Uniden speakerphone cordless phone \$109.95
BC55XLT-A Bearcat 10 channel scanner \$114.95
AD100-A Plug in wall charger for BC55XLT \$14.95
PS001-A Cigarette lighter cable for BC55XLT \$14.95
VC001-A Carrying case for BC55XLT \$14.95
BC70XLT-A Bearcat 20 channel scanner \$159.95
BC142XL-A Bearcat 10 ch. 10 band scanner \$84.95
BC147XLT-A Bearcat 16 ch. 10 band scanner \$94.95
BC172XL-A Bearcat 20 ch. 11 band scanner \$134.95
BC177XLT-A Bearcat 16 ch. 11 band scanner \$134.95
BC590XLT-A Bearcat 100 ch. 11 band scanner \$194.95
BC760XLT-A Bearcat 100 ch. 12 band scanner \$254.95
BC002-A CTCSS tone board for BC590/760XLT \$54.95
BC003-A Switch assembly for BC590/760XLT \$22.95
BC855XLT-A Bearcat 50 ch. 12 band scanner \$199.95
BC1-A Bearcat Information scanner with CB \$129.95
BC330A-A Bearcat Information scanner \$99.95
BC560XLT-A Bearcat 16 ch. 10 band scanner \$94.95
BP205-A Ni-Cad batt. pack for BC200/BC100XLT \$39.95
TRAVELLER2-A Grundig shortwave receiver \$89.95
COSMOPOLIT-A Grundig shortwave receiver \$199.95
SATELLIT500-A Grundig shortwave receiver \$679.95
SATELLIT650 Grundig shortwave receiver \$949.95
ATS803A-A Sangean shortwave receiver \$159.95
74102-A Midland emergency weather receiver \$39.95
77116-A Midland CB with VHF weather & antenna \$66.95
77118-A Midland CB mobile with VHF weather \$62.95
77913-A Midland CB portable with VHF weather \$79.95
76300-A Midland CB base station \$92.95
FBE-A Frequency Directory for Eastern U.S.A. \$14.95
FBW-A Frequency Directory for Western U.S.A. \$14.95
RFD1-A MI, IL, IN, KY, OH, WI Frequency Directory \$14.95
RFD2-A CT, ME, MA, NH, RI, VT Directory \$14.95
RFD3-A DE, DC, MD, NJ, NY, PA, VA, WV Dir. \$14.95
RFD4-AAL, AR, FL, GA, LA, MS, NC, PR, SC, TN, VI \$14.95
RFD5-A AK, ID, IA, MN, MT, NE, ND, OR, SD, WA, WY \$14.95
RFD6-A CA, NV, UT, AZ, HI, GU Freq. Directory \$14.95
RFD7-A CO, KS, MO, NM, OK, TX, Freq. Directory \$14.95
PWB-A Passport to World Band Radio \$16.95
ASD-A Airplane Scanner Directory \$14.95
TSG-G7 "Top Secret" Registry of U.S. Govt. Freq. \$16.95
TTC-A Tune in on telephone calls \$14.95
CBH-A Big CB Handbook/AM/FM/Freeband \$14.95
TIC-A Techniques for Intercepting Communications \$14.95
RRF-A Railroad frequency directory \$14.95
EEC-A Embassy & Espionage Communications \$14.95
SMH-A2 Scanner Modification Handbook, Vol. 2 \$18.95
LIN-A Latest Intelligence by James E. Tunnell \$16.95
A60-A Magnet mount mobile scanner antenna \$34.95
A70-A Base station scanner antenna \$34.95
USAMM-A Mag mount VHF ant. w/ 12' cable \$39.95
USAK-A ¾" hole mount VHF ant. w/ 17' cable \$34.95
Add \$4.00 shipping for all accessories ordered at the same time.
Add \$15.00 shipping per radio and \$4.00 per antenna.

BUY WITH CONFIDENCE

Michigan residents please add 4% sales tax or supply your tax I.D. number. Written purchase orders are accepted from approved government agencies and most well rated firms at a 10% surcharge for net 10 billing. All sales are subject to availability, acceptance and verification. Prices, terms and specifications are subject to change without notice. All prices are in U.S. dollars. Out of stock items will be placed on backorder automatically or equivalent product substituted unless CEI is instructed differently. A \$5.00 additional handling fee will be charged for all orders with a merchandise total under \$50.00. Shipments are F.O.B. CEI warehouse in Ann Arbor, Michigan. No COD's. Not responsible for typographical errors.

Mail orders to: Communications Electronics™, Box 1045, Ann Arbor, Michigan 48106 U.S.A. Add \$15.00 per radio for U.P.S. ground shipping and handling in the continental U.S.A. For Canada, Puerto Rico, Hawaii, Alaska, or APO/FPO delivery, shipping charges are two times continental U.S. rates. If you have a Discover, Visa, American Express or MasterCard, you may call and place a credit card order. 5% surcharge for billing to American Express. For credit card order, call toll-free in the U.S. Dial 800-USA-SCAN. For information call 313-996-8888. FAX anytime, dial 313-663-8888. Order today.

Scanner Distribution Center™ and CEI logos are trademarks of Communications Electronics Inc.
Sale dates 3/15/91 - 10/31/91 AD #032591-A
Copyright © 1991 Communications Electronics Inc.

For more information call
1-313-996-8888

Communications Electronics Inc.
Emergency Operations Center

P.O. Box 1045 □ Ann Arbor, Michigan 48106-1045 U.S.A.
For orders call 313-996-8888 or FAX 313-663-8888

YOU AIN'T HEARD NOTHIN...YET!

THE 'TOP SECRET' REGISTRY OF U.S. GOVERNMENT RADIO FREQUENCIES

25 TO 470 MHz
BY TOM KRIBTEL, K2ARS

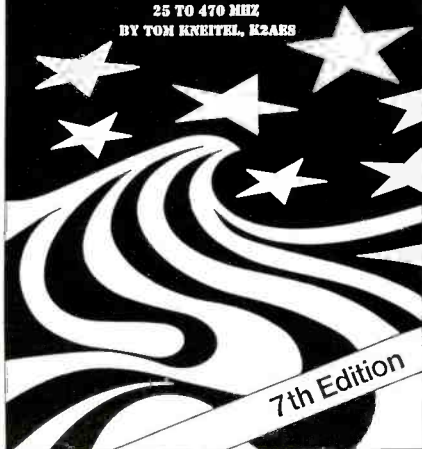

7th Edition

Since 1967, CRB Research has been the world's leading publisher and supplier of unique hobby and professional books and information including:

- Scanner Frequency Guides
- Shortwave Frequency Guides
- Military/Federal Communications
- Broadcast Station Registries
- Undercover Communications
- Survival Communications
- Covert Operations
- Electronic Espionage
- Surveillance
- Monitoring
- Cryptography & Codes
- Bugging
- Wiretapping
- Communications Antennas
- Electronics & Projects
- Computer Technology
- & Other Related Topics!

Ask For Big Free Catalog!

New titles are constantly being added to our exciting catalog. If it's interesting and unusual, we've got it. You'll see! Ask for our latest FREE catalog.

CRB RESEARCH

P.O. Box 56 Commack, NY 11725

CIRCLE 131 ON READER SERVICE CARD

Amateur Radio Satellite Communications

Typical Configuration for AO-16, DO-17, WO-18, and LO-19

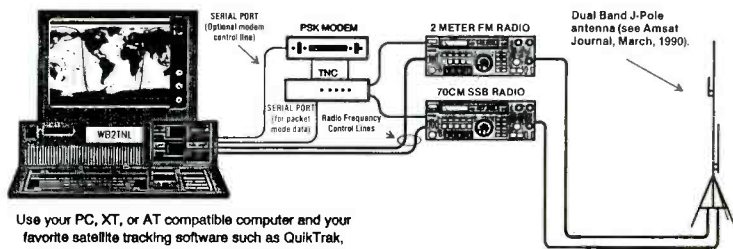

Use your PC, XT, or AT compatible computer and your favorite satellite tracking software such as QuikTrak, InstantTrack, ORBITS (all available from AMSAT).

JOIN AMSAT

Benefits for you

The AMSAT Journal, OSK Bureau, help fund satellite construction, member discounts on software, publications and other items.

New Member Renewal/Reinstatement Member

Name _____

Street _____

City _____

State/Prov. _____ Country _____ Zip/PC _____

Ques are \$30 US payable to AMSAT-NA, 850 Sloop Ave., Silver Spring, MD 20910 or call (301) 589-6062. Call or write for club and international rates.

VISA MC _____

Signature _____ Expires _____

NOTES:

1. Use the best coax possible (9913 or hardline).
2. The computer interface to the radios provides real-time doppler correction via the Kansas City Tracker/Tuner package. Contact L.L. Grace, 41 Acadia Drive, Voorhees, NJ 08043.
3. Suitable PSK modems are the PacComm PSK-1, the TAPR PSK modem, and the G3RUH 1200bps modem.

Amateur Radio Satellite Communications

Typical Configuration for AO-10, AO-13, and FO-20

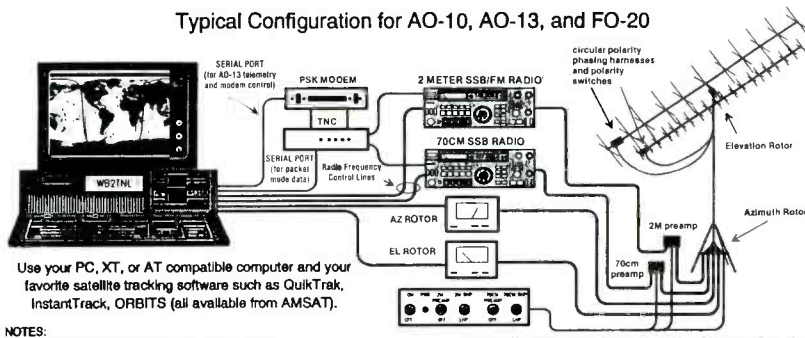

Use your PC, XT, or AT compatible computer and your favorite satellite tracking software such as QuikTrak, InstantTrack, ORBITS (all available from AMSAT).

NOTES:

1. Put preamps as close to the antenna as possible.
2. Use the best coax possible (9913 or hardline) between the shack and the tower.
3. Use flexible coax (RG-213, RG-214) between the tower and the antenna.
4. Use outdoor rotor cable to connect the control box to the tower.
5. The computer interface to the rotors and radios provides real-time tracking and doppler correction via the Kansas City Tracker/Tuner package. Contact L.L. Grace, 41 Acadia Drive, Voorhees, NJ 08043.
6. PSK modem and TNC are for AO-13 telemetry (use PacComm PSK-1 or G3RUH 400bps modem) or FO-20 Mode JD "BBS in the sky" (use PacComm PSK-1, TAPR PSK modem, or G3RUH 1200bps modem).
7. Radio frequency control lines are for automatic doppler correction which is particularly useful on FO-20 Mode JD.

AO-10 = Oscar 10	145.810-145.975 MHz
AO-13 = Oscar 13	145.810-145.975 MHz
FO-20 = Oscar 20	435.715-435.996 MHz
	435.796-435.900 MHz

AO-18 = Pacsat 16	437.026 MHz
DO-17 = Dove	145.825 MHz
WO-18 = Webersat	437.075 MHz
LO-19 = LuSat	437.153 MHz

quency space and at an affordable price to the customer. Audio Subcarriers can be sent between 5 and 8 MHz on the transponder (satellite repeater). Many special groups take advantage of this service. For example, Moody Bible Institute, CNN News, AFRTS, Musak, ESPN and most of the Jazz, Country and Rock (and even Big Band) music networks are distributed nation wide by satellite. These can be FM, stereo or monaural.

Most SCPC transmissions are FM, though you could still hear a SSB signal from time to time. SCPC is a much narrower mode of operation and you do not have to receive (demodulate) a video signal in order to extract audio. SCPC does not have the fidelity available to audio subcarriers but it is more economical. It is used by the news

networks, local TV and radio stations, the government and the intelligence services. The latter uses digital modes of communication, encrypted, of course.

SCPC signals can be intercepted if you already have a TVRO. You need a scanner that will receive the frequency range of your down-converters' frequency. There are several frequency ranges used for down-converters: 950 to 1450 MHz, 270 to 77 MHz are the most common. If your scanner does not tune these frequency bands, you may be able to intercept the signal at the receiver's second IF (Intermediate Frequency). This is usually 70, 134 or 380 MHz. You simply connect the output of your down or block converter to the input of your scanner. If you intercept the signal at the se-

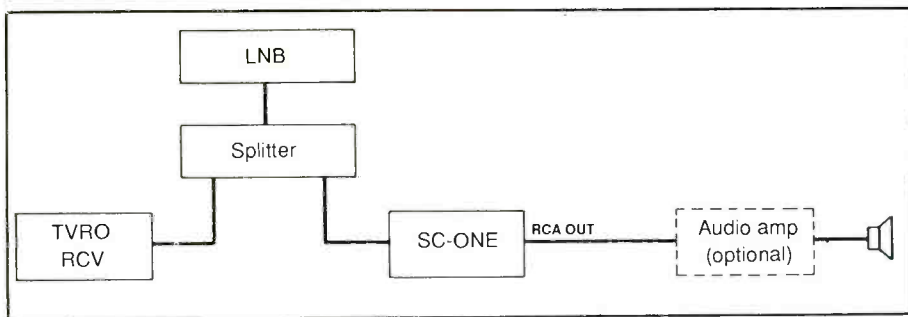

SCPC reception at block or down converter. An SC-one or scanner can be used with isolated through tap (splitter).

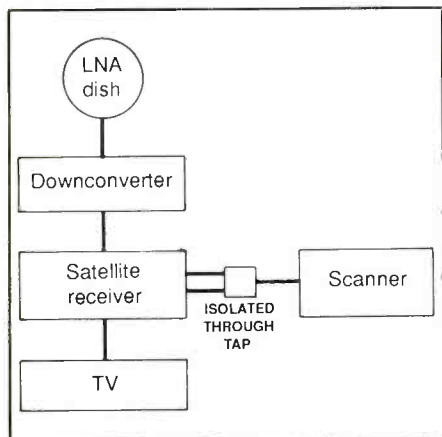

SCPC reception using 2nd IF or satellite receiver.

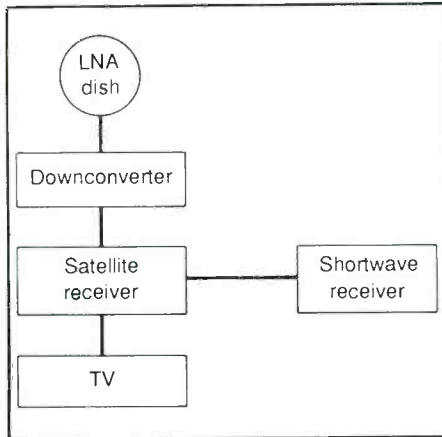

FDM (telephone) reception through the unclamped composite video output.

cond IF, you will only be able to hear what is on the channel (transponder) that your TVRO is tuned to at that or any given moment. You will need both the TVRO tuner and your scanner to search all SCPC. Be sure to use an isolated through tap to connect your scanner to your TVRO system. This will keep the unwanted DC on the coax from entering your scanner.

In addition to SCPC and Audio Subcarriers there is FDM, Frequency Division Multiplex. This is used for the transmission of domestic and international telephone calls by satellite. To tune FDM you need an HF SSB receiver. The output of the TVRO (unclamped) composite baseband is fed into the receiver's antenna input. You will then tune from .5 through 10.75 MHz to find the telephone signals.

On a final note, we must not forget your antenna. Any outside antenna is better than an inside one. There are many multi-band antennas available from whips to beams. My personal favorite is the discone. It is a wide-band antenna. Models can be found which operate from 25 to 1300 MHz. A multi-band ground plane or vertical also works just as well for scanners that are not continuous coverage.

Hopefully, this has given you some idea about what is required to become radio active in the satellite bands. Next time we'll take an in-depth look at where to look and for what, now that you know how to look.

Improve Your Scanning Coverage!

GRE America is proud to introduce a new family of products to enhance your scanning pleasure! First, GRE has designed the new **Super Converter 9001** for base model scanners. The 9001 converts 810 MHz - 950 MHz down to 410 MHz - 550 MHz. The 9001 is the perfect alternative to buying a new, expensive scanner covering the 800 MHz band. Next, GRE announces the new **Super Amplifier 3001** for base model scanners. The 3001 will increase gain by as much as 20 dB, and is engineered to help scanners with low sensitivity pull in weak signals. Both products use BNC connectors, (1) 9 volt battery and have an off/pass switch for returning to normal operation.



Super Converter 9001 & Super Amplifier 3001

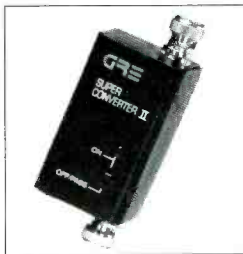

Super Converter II



Super Amplifier



All-Band Antenna

U.S. & International Distributorship inquiries welcome. Please call GRE for further information!

Let GRE Manufacture Your Radio Products!

GRE America, Inc. is a leading OEM developer and manufacturer of radio telecommunications products such as:

- Cordless Telephones
- CB & Marine Radios
- Spread Spectrum "engines"
- Remote Monitoring Systems

If you need a high quality, cost competitive, reliable manufacturer, GRE will provide you with a free production quotation.

For more information, please call GRE at (800) 233-5973. GRE is a subsidiary of General Research of Electronics, Inc.

GRE GRE America, Inc.

GRE America, Inc.
425 Harbor Blvd., Belmont, California 94002
(415) 591-1400 Outside California: (800) 233-5973

SCANNING VHF/UHF

BY CHUCK GYSI, N2DUP

MONITORING THE 30 TO 900 MHz "ACTION" BANDS

The weather is just starting to turn warm, yet wet, on many areas. Now is a good time to climb up on the roof and see how your antennas fared over the winter. The cold and harsh weather can loosen coaxial connectors, as well as the antenna mounts themselves. Carry along some wrenches and if you haven't already done so, seal over your connectors with commercially available coaxial-connector seal (available at radio shops) or at least use some electrical tape to seal over your connectors. Letting moisture in your connectors is sure to shorten the life of your costly antennas. Don't wait for the weather to turn cold again before you climb up on the roof.

From Harrington, Delaware, Brian S. Delinger says he owns a Realistic PRO-2021 scanner that was discontinued, but he lost the instruction manual. He says he's tried to obtain another without success (have you tried having a local Radio Shack store order one for you?). He says he is having a problem entering frequencies into the memory. Here's how to do it on a PRO-2021: Manually select the channel in which you wish to enter a new frequency. Then press PROGRAM. Punch in the new frequency, then hit ENTER. The new frequency is entered. You then can step to the next channel (if you want to enter another frequency, just push PROGRAM again; otherwise MANUAL will do the trick, too). Let's hope that this helps, Brian.

Chris Cuomo writes in to say that he has been scanning since 1986 and owns a Bearcat 175XL. He says that he is an auto racing fan and would like to correspond with anyone who monitors communications at major races. Chris can be written to at 670 Third Ave., Verona, PA 15147. Scanner buffs who like to monitor race communications might be interested in joining the Frequency Fan Club, which publishes regular bulletins during the race season listing frequencies used by race teams and officials. The club also maintains a telephone hotline listing for day-of-the-race frequencies (which have a tendency to change). For more information on the club, write to: Frequency Fan Club, PO Box 991, Mulberry, FL 33860.

From Baton Rouge, Louisiana, Mark Marchiafava writes in to report that the East Baton Rouge Sheriff's Office has moved from VHF low band to 800 MHz. The new frequencies are: 854.2375, 857.7125, 858.7125, 859.7125 and 860.2375. Mark adds that the old frequencies (39.54, 39.88, 39.40 and 39.78 MHz) are still being used.

Jeff Tunnell writes from Bayonne, New Jersey, to say he recently became interested

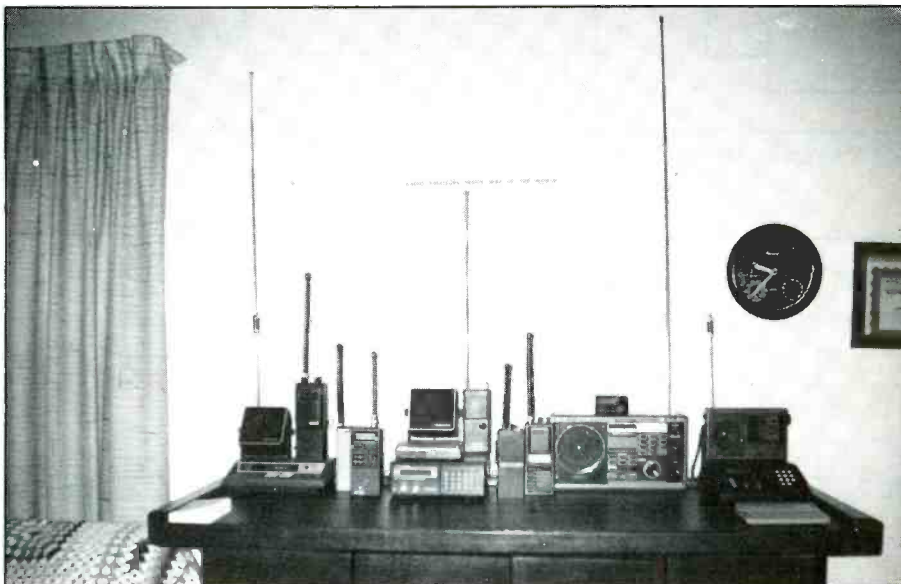

Here's the ready-to-roll listening station of George Speck, Registered Monitor, KTX5FT, of Fort Worth, Texas. Among the base and handheld scanners and monitors shown are: Regency R-1077, Cobra SR900, Realistic PRO-2002, Bearcat 70XLT, Realistic PRO-26, Realistic PRO-34 and Realistic PRO-27.

in scanning the airwaves and wants to know how to receive QSL cards. First of all, don't count on getting too many QSL "cards" from VHF and UHF stations. Unless you prepare a QSL card for such stations to return to you, expect to get back a letter from the police chief of a department you heard, or a memo from a secretary of a business that you may have tuned in. These stations really aren't used to getting QSL requests, and quite frankly, may be dumbfounded about what to do with it. On the other hand, shortwave and broadcast stations usually have printed QSL cards they send out to verify reception.

Jot down as much detail as possible about your reception, such as frequency, time and day, program content heard, how well the reception was, whether there was much fading of the signal, etc. The more detailed your QSL request is, the more valuable it is to the radio station that receives it and the better your chances are to receive a QSL card in return. For some countries, you may need to include an international Reply Coupon (IRC). These coupons can be purchased at post offices and can be redeemed in any country for postage to mail a letter. This might help the station verify your request if you prepay the postage. You may even want to prepare your own QSL card to request cards from other stations. When I was in junior high school, a shop teacher of mine drew a tropical-looking guy with a set of tin-can headphones and I left spaces to fill in QSL requests. I then printed several of

these cards on the shop's offset press and used these to request QSL cards from many broadcasters. You can even get a card printed commercially if you are inclined to do so. But remember, the more information you include, the better your chances are for a reply. Happy QSL'ing—and don't forget the low band skip DX stations on VHF!

William Bestwick of Wilmington, Delaware, tells us that the police and fire departments in his city have made the switch to 800 MHz. The new frequencies, which are shared by both departments, are: 856.7625, 857.7625, 858.7625, 859.7625 and 860.7625 MHz. The former frequencies used were: 155.130 (F-1 dispatch), 155.610 (F-2 data), 155.640 (F-3 car to car), 154.860 (statewide mutual aid) and 154.965 (fire). Apparently, though, the fire department is simulcasting their signal on both 800 MHz and 154.965. Some other frequencies Bill passes along for this area are: 151.070, Delaware Memorial Bridge maintenance units; 453.9625, Delaware Memorial Bridge; and 173.225, Wilmington News Journal newspaper. His equipment consists of a Realistic PRO-2005, a Bearcat 210, a Bearcat 200XLT, a Sonar page VHF receiver and a Regency R-4020.

POP'COMM's VHF low band skip expert, Chuck Robertson, comments on Pete Croydon's question in the December 1990 issue of Scanning VHF/UHF. Chuck says that he knows of only one confirmed Aus-

(Continued on page 76)

Reference

1991 EDITIONS 1991 RADIO AMATEUR CALLBOOKS

NORTH AMERICAN EDITION

Fully updated and edited to include all the latest FCC and foreign government call signs and address to Hams in North America. Includes plenty of handy operating aids such as time charts, QSL bureau addresses, census information and much more. Calls from snowy Canada to tropical Panama. Now is the time to buy a new Callbook when you'll get the most use out of your investment. © 1990.

CB-NA91 Softbound \$29.95

INTERNATIONAL EDITION

QSLs are a very important part of our hobby. All sorts of awards, including the coveted DXCC, require confirmation of contact before the award can be issued. Of special interest, addresses are being added daily for Hams in the USSR and other countries. While by no means complete, it's a start and will be of tremendous help in getting QSLs. Handy operating aids round out this super book value. © 1990.

CB-191 Softbound \$29.95

BUY 'EM BOTH SPECIAL

CB-NA191 REG. \$59.90 ONLY \$54.95 SAVE \$5.00

THE 1991 ARRL HANDBOOK

Revised and updated with the latest in Amateur technology, now is the time to order your very own copy of the world famous ARRL HANDBOOK. In addition to being the definitive reference value for your Ham shack, there are plenty of projects for every interest in Amateur Radio -- from antennas for every application to the latest state-of-the-art projects -- you'll find it all in the 1991 HANDBOOK. Over 1100 pages. ©1990.

AR-HB91 Hardbound \$24.95

NEW BOOKS

WEATHER SATELLITE HANDBOOK New ARRL 4th Edition

by Ralph Taggart, WB8DQT

Taggart has long been recognized as one of the foremost experts on weather satellite picture reception. This new edition of his famous book has been updated and expanded to include all the latest information on satellite picture reception. Subjects covered include a complete section on what satellites are in orbit, everything you'd want to know on what kind of antenna, receiver, video formats and displays to use, plus much more! You get all the information you need to get your satellite system up and running. © 1990 4th Edition

AR-WSH Softbound \$19.95

PRACTICAL ANTENNA HANDBOOK

BY Joe Carr, K4IPV

A comprehensive blend of theory and practical antenna applications make this new book by noted author Carr, a valuable book to have on hand. Features detailed analysis and construction information for all kinds of antennas, an explanation of the secrets of radio propagation, theory and use of transmission lines, a comprehensive overview of the radio spectrum as well as 22 BASIC programs for designing antennas. Learn from an expert -- get this book today. © 1990 1st edition 448 pages

T-3270 Softbound \$21.95

FREQUENCY MASTER FILE Vol. 1

Federal Assignments

by The Communications Research Council

Contains all the latest information on frequencies in use by the US Government. Over 200 pages of listings arranged by Government agency, location, call sign and other available information. © 1990 1st edition 215 pages

ATSI-FA1 Softbound \$24.95

PASSPORT TO WORLDBAND RADIO 1991 Edition

Brand new, fully revised and expanded. Now includes a bigger and better SWL'S buyer's guide. Also includes all the latest broadcast schedules from countries around the world. Great reference text for Hams as well as the serious SWL and casual listener. ©1990

IBS-RD191 Softbound \$16.95

POP'COMM's CQ HR BOOKSTORE BOOK IDEAS (800) 457-7373 8AM-5PM EST CALL TOLL FREE

Shipping and handling \$3.75 to US and Canada.

All others addresses FOB Greenville, NH, USA plus \$3.75 handling

Fun Reading

BEVERAGE ANTENNA HANDBOOK by Victor Misek, W1WCR

Misek delves deep into the secrets of the single wire Beverage and SWA (Steerable Wave Antenna) with helpful hints and tips on how to maximize performance based upon wire size, height above ground, overall length and impedance matching. Transformer design information for both termination and freeline matching is completely revised. ©1987. 80 pages, 2nd Edition.

VM-BAH Softbound \$14.95

1991 EQUIPMENT BUYER'S GUIDE

Brand new and fully up-to-date. Complete listing of equipment available from the various equipment and accessory manufacturers. Includes radios and accessories plus helpful hints and tips and a complete listing of addresses and telephone numbers. ©1990

CQ-EQP91 Softbound \$4.95

WORLD RADIO TV HANDBOOK 1991 Edition

Loaded with the latest call signs, frequencies and other important information for radio and TV broadcasting around the world. Covers LF, MF, shortwave and TV services. Also has equipment reviews and other special features. ©1990. 45th Edition.

GL-WRTV91 Softbound \$19.95

1990 ANTENNA BUYER'S GUIDE

Looking for the latest in antennas? It's all here in the CQ Antenna Buyer's Guide. Crammed full of articles, product information and a who's who section listing all of the manufacturers and importers. Get your's now and start planning for Spring 1991 antenna projects. © 1990

CQ-ANT90 Softbound \$4.95

TOMMY ROCKFORD BOOKS by Walter Tompkins, K6ATX

These thrilling stories introduced a whole generation of Hams to the wonderful world of Amateur Radio. Great reading, and gift ideas for all levels of Amateur Radio Interest. Each story is full of action packed excitement.

<input type="checkbox"/> AR-DV	Death Valley QTH	Softbound \$4.95
<input type="checkbox"/> AR-SO	SOS At Midnight	Softbound \$4.95
<input type="checkbox"/> AR-CO	CQ Ghost Ship	Softbound \$4.95
<input type="checkbox"/> AR-DX	DX Brings Danger	Softbound \$4.95
<input type="checkbox"/> AR-GC	Grand Canyon QSO	Softbound \$4.95
<input type="checkbox"/> AR-MO	Murder by QRM	Softbound \$4.95
<input type="checkbox"/> AR-TR	All 6 books, Reg. \$29.70 Save \$4.75	\$24.95

Study Guides

ARRL LICENSE MANUAL

by ARRL Staff

ARRL License Manuals are keyed to the latest Exam. Written in easy-to-read conversational style that enhances understanding without scaring the student away. All technical subject areas are explained in clear terminology and with plenty of illustrations, diagrams and schematics. Each book has the official ARRL multiple choice question Pool with answers and a key to the Exam syllabus for reference to other study applications. These are the study guides to have. Latest editions shipped.

AR-T Tech Softbound \$6.00

AR-G General Softbound \$6.00

AR-AG Advanced Softbound \$5.00

AR-EG Extra Softbound \$8.00

ARRL CODE TAPES

Four new sets of code practice tapes from the ARRL. Each set consists of two 90 minute cassettes and gives you almost 3 full hours of practice. Great way to study when you can't get on the air.

AR-1 5-10 WPM \$9.95

AR-2 10-15 WPM \$9.95

AR-3 15-22 WPM \$9.95

AR-4 13-14 WPM \$9.95

FCC RULE BOOK

More than the FCC part 97 rules and regulations. It presents detailed explanations of FCC rules and is written in an easy-to-read conversational style. You get the insider's view of the FCC. You also get a broad overview of how international relations impact your hobby. Every U.S. amateur should have a copy of this latest FCC Rules and Regulations in their Hamshack. (C) 1989, 8th Edition

AR-RB Softbound \$9.00

AMECO STUDY GUIDES

Designed for VEC Exams

AMECO Study Guides are taken from the latest FCC/VEC Exam question pool. Each book has the latest questions along with the ARRL/VEC multiple choice answers, immediately followed by a full discussion explaining each question. While nothing can guarantee that you will pass, AMECO study guides will make sure that you are fully prepared and ready to go. Written in clear, concise, easy-to-read format, each question is fully explained. Novice and General books are cross referenced to AMECO's 102-01 for a more thorough explanation.

27-01 Novice Class \$5.95

28-01 Technician Class \$4.95

12-01 General Class \$5.95

26-01 Advanced Class \$4.95

17-01 Extra Class \$5.95

102-01 Radio Amateur Theory Course \$6.95

AMECO CODE COURSE (MS-DOS computers)

Take random code practice or listen to existing ASCII files at your chosen code speed. A comprehension quiz is included that tests your code copying ability at any point during the learning process. You can also use the computer as a code practice oscillator. Finally, the computer will generate QSOs that are very similar in format to VEC code examinations. (C) 1987

107-PC (MS-DOS) \$19.95

Get Your Novice Ticket

TUNE IN THE WORLD WITH HAM RADIO by ARRL staff 8th Edition

NOW INCLUDES TWO C-90 CODE STUDY TAPES!

This package has been revised to cover new digital and voice Novice requirements and contains THE goodies needed by the beginner to get started in Amateur Radio. Assuming that you have no prior knowledge of radio, the reader is taught how to pass the Novice exam, both code and theory, and how to set up a station. Unique code study method makes learning the Morse code easy as 1-2-3. And it's full of illustrations to help clarify difficult technical points. 160 pages (C) 1989 8th Edition.

AR-HR Softbound \$18.95

There's a situation which a lot of new SWL's find themselves in: they've scrimped and saved, and finally have that super-deluxe receiver they've dreamed about in front of them. They then start tuning for those rare DX stations they've seen others log, and—well, *nothing*. Those DX stations still remain elusive, and in fact those SWL's don't notice that much improvement in stations they heard before. Yet they notice that other SWL's are using the same model receiver to hear all sorts of good stuff. There's obviously only one answer, they think—they got stuck with a lemon.

But there's another possible answer, and it's actually the most likely one. However, it's one new SWL's are reluctant to face up to: *they don't know how to properly use a shortwave receiver*. There's nothing wrong with the receiver; the problem is with the listener!

Let's face it, any complex, high-performance device takes certain skills and experience to use properly. This is true whether you're talking about sports cars, telescopes, computers, or shortwave receivers. The good news is that anyone can learn such skills and techniques. The bad news—sort of—is that you'll have to invest some time and effort to learn them.

Practice Makes Perfect

The first thing you need to learn about your shortwave receiver is how the controls work. And I don't mean the controls that are described in the owner's manual! What actual effect do the various controls have on what you hear? And how do the different controls interact with each other? For example, the effectiveness of a noise blanker can really vary depending upon the setting of the receiver's automatic gain control (AGC). You need to know the results you can expect with different combinations and settings.

The way to learn how to use your receiver's controls is by practicing on your local AM broadcast stations. Such stations are strong enough so that you'll easily notice any subtle differences produced by different settings. Those subtle differences aren't important when listening to your local AM stations, but they can make the difference between hearing a weak DX station or not!

By the way, don't be too surprised if the controls work a little bit differently from the way they're described in the manual. For one thing, the slight variations in the components making up a receiver and how well a receiver is aligned at the factory means that each receiver will have its own "personality." More important, however, is the fact

that manuals are often written by people who have never used the receiver. The manual writers rely on design engineers who tell them how the various controls are "supposed" to work—but how they work in the real world is sometimes a different story! If there's a conflict between what the manual says and what your ears tell you, trust your ears!

Don't Be So Sensitive

A lot of SWL's run their receivers with the sensitivity set to *phaser-stun*. They turn the RF gain control all the way up and turn their receiver's preamp (if it has one) on. These SWL's can hear signals that are fainter than faint. And in a lot of cases that's not too good.

Why? The major international broadcasting bands are loaded with high-power signals. When I first got interested in SWL'ing back in the 1960s, a station running 100 kilowatts of power was big-time stuff. Today, 500 kilowatt transmitters are a dime a dozen. All that radio energy can do funny things to the radio frequency amplifier and mixer stages of a receiver, producing spurious responses ("ghost" signals), distortion, and cross-modulation in which the audio of a loud station is superimposed on that of a station you want to hear. And these effects get worse as your receiver's sensitivity goes up.

Another thing to keep in mind when tuning frequencies below about 5 MHz is that atmospheric noise increases as the frequency drops. If you have a highly sensitive receiver on these frequencies, then you'll often just hear noise better instead of a station you're interested in!

Here's a tip that's served me well: *use only as much sensitivity as you need to hear a station clearly*. In other words, don't be afraid to back off that RF gain control or switch in an attenuator. I do most of my tuning with my receivers' RF gain controls set between one-half and two-thirds of maximum. Sometimes I find it best to reduce the setting below one-half maximum. Very seldom do I find it necessary to crank it up to maximum or switch in a preamplifier. When I need or can use all the sensitivity I can get—such as when tuning frequencies above 15 MHz or on exceptionally quiet nights below 5 MHz—I'll use it, but most of the time I don't need it. And I bet your situation isn't a lot different from mine!

One trick that works well with older vacuum tube receivers (such as my beloved Hammarlund HQ150 and HQ180A models) is to turn the volume control to maximum and use the RF gain control as the "Volume" control. This trick makes SSB reception easier

on such older receivers, and helps reception of weaker AM signals. In my experience, this doesn't work quite so well on modern receivers, but it might help in some situations and is certainly worth trying.

Secrets Of The Automatic Gain Control (AGC)

Many receivers include an automatic gain control (AGC) or automatic volume control (AVC) circuit. These circuits are designed to keep the volume you hear relatively constant regardless of changes in signal strength. They work by sampling the strength of the received signal and cranking up the receiver's sensitivity when the signal is weak or fades and by reducing sensitivity when the signal is strong or increasing in strength ("fading" up). So all you have to do is keep the AGC/AVC circuit in your receiver on all the time, right?

Well, not always. For one thing, the AGC/AVC circuit slightly reduces the maximum sensitivity of your receiver. If you're trying to hear a faint signal right at the noise level, switch the AGC/AVC off. Another time to switch this circuit off is when you're trying to hear a station under a strong unmodulated carrier on the same frequency, such as often happens in the early morning hours on the AM broadcast band. The AGC/AVC will be "governed" by the unmodulated carrier, making the station underneath difficult to hear. Turning the AGC/AVC off can make a dramatic improvement in the other station's readability.

Several advanced receivers provide two or three different "speeds" for their AGC/AVC circuits. "Speed" refers to how rapidly the circuit reacts to changes in the received signal level. Normally, you'd use a slower speed with AM signals while a fast speed would be used with SSB or CW. But these aren't hard and fast rules, especially if you're trying to hear a "fluttering" or rapidly fading AM signal. A little experimentation will reveal which AGC/AVC settings on your receiver give the best results for different reception conditions.

Exalt That Carrier!

An AM signal has two identical sidebands and a carrier. SSB (single sideband) only uses one of those sidebands and disposes with the carrier altogether. Most receivers today are capable of superb SSB reception, and usually offer a choice between USB (upper sideband) and LSB (lower sideband) reception. While this is great for hams and other signals in SSB, it also means you can tune AM signals as if they were SSB signals.

This is known as *exalted carrier SSB* (ECSSB) reception, and can enable you to hear AM signals under conditions where normal AM reception is difficult or impossible.

To tune AM using ECSSB is not much more difficult than listening to ordinary SSB signals. When you find an AM signal in heavy interference, try to determine which "side" of its frequency has the least interference. For example, suppose the station you want to hear is on 9600 kHz, but there is a strong station on 9595 kHz causing very heavy interference, while a station on 9605 kHz is only causing moderate interference. In this case, you would tune for the target station's *upper sideband*—the one above 9600 kHz. (All AM frequencies are given as the frequency of the carrier; one sideband lies above the carrier frequency while another lies below the carrier.)

To tune that upper sideband, you would set your receiver's mode switch to USB and use the selectivity position you normally use for SSB (this will usually be a filter from 2.4 to 3 kHz in bandwidth). Next—and this is the important part—very carefully tune your receiver so that the carrier frequency of the station you want to hear and the frequency of the replacement carrier generated in your receiver for SSB/CW match. If there's a difference in those two frequencies, you'll hear a high-pitched whistle known as a *heterodyne*. As the frequencies

become more equal, the pitch of the heterodyne whistle will drop. Eventually, a point will be reached where the heterodyne disappears altogether. This point is known as *zero beat*, and you are tuned only to one sideband of the AM signal.

Since the bandwidth of SSB filters are narrow, the audio of a signal received via ECSSB can be a bit "clipped," with a loss of higher audio frequencies. However, ECSSB can mean the difference between audio you can understand versus a signal buried under interference. ECSSB reception is one trick you should master if you're seriously interested in chasing DX!

Tuning Off Frequency

You might call this technique "son of ECSSB." You don't need both sideband to hear an AM signal; all you need is one sideband and the carrier. The way to capture the carrier and just one sideband is to use your receiver's SSB filter and tune a kilohertz or two above or below the station's frequency. For example, suppose you have a station on 4800 kHz that is suffering heavy interference from a station on 4795 kHz when you're using your receiver's wide bandwidth. You might get better reception by switching to a narrow bandwidth and tuning to 4802 kHz or so. This will place the station's carrier at the edge of the narrow band-

width, and will let it come through along with the upper sideband.

Why use this technique instead of ECSSB? Sometimes it's hard to tune for zero beat, particularly if there's another carrier near the station you want to hear. Give both a try and see which works best for you.

Otherness

Does your receiver have a notch filter? If so, tune it *slowly*. A notch filter works by taking out a very narrow "slice" of the received signal. If you tune it too fast, you won't be able to notice when it takes out an interfering signal or heterodyne.

Noise blankers and limiters are terrific, but sometimes they can produce distortion or cross-modulation if your receiver's pre-amplifier is on or if the RF gain control is high. It might help to reduce your receiver's sensitivity if noise is high.

Your receiver has its personality, and there are probably some things that you can do with it that I haven't mentioned here. So take time to get to know your receiver and what it can do—after all, it's the best friend you'll ever have in DX'ing! ■

Editor's Note: Harry Helms is the editor of the Umbra et Lux newsletter, c/o DX/SWL Press, 10606-8 Camino Ruiz #174, San Diego, CA 92126.

ICOM's IC-R9000 The Best Of Both Worlds

The pacesetter IC-R9000 truly reflects ICOM's long-term commitment to excellence. This single-cabinet receiver covers both local area VHF/UHF and worldwide MF/HF bands. It's a natural first choice for elaborate communications centers, professional service facilities and serious home setups alike. Test-tune ICOM's IC-R9000 and experience a totally new dimension in top-of-the-line receiver performance!

Complete Communications Receiver. Covers 100KHz to 1999.8MHz, all modes, all frequencies! The general coverage IC-R9000 receiver uses 11 separate bandpass filters in the 100KHz to 30MHz range and precisely-tuned bandpass filters with low noise GaAsFETs in VHF and upper frequency bands. Exceptionally high sensitivity, intermod immunity and frequency stability in all ranges.

Multi-Function Five Inch CRT. Displays frequencies, modes, memory contents,

operator-entered notes and function menus. Features a subdisplay area for printed modes such as RTTY, SITOR and PACKET (external T.U. required).

Spectrum Scope. Indicates all signal activities within a +/-25, 50 or 100KHz range of your tuned frequency. It's ideal for spotting random signals that pass unnoticed with ordinary monitoring receivers.

1000 Multi-Function Memories. Store frequencies, modes, and tuning steps. Includes an editor for moving contents between memories, plus an on-screen notepad for all memory locations.

Eight Scanning Modes. Includes programmable limits, automatic frequency and time-mark storage of scanned signals, full, restricted or mode-selected memory scanning, priority channel watch, voice-sense scanning and scanning a selectable width around your tuned frequency. Absolutely the last word in full spectrum monitoring.

Professional Quality Throughout. The revolutionary IC-R9000 features IF Shift, IF Notch, a fully adjustable noise blanker, and more. The Direct Digital Synthesizer assures the widest dynamic range, lowest noise and rapid scanning. Designed for dependable long-term performance. Backed by a full one-year warranty at any one of ICOM's four North American Service Centers!

The ICOM logo consists of a stylized 'O' symbol above the letters 'I', 'C', 'O', and 'M' in a bold, sans-serif font.

First in Communications

ICOM America, Inc., 2380-116th Ave. N.E., Bellevue, WA 98004
Customer Service Hotline (206) 454-7619
3150 Premier Drive, Suite 126, Irving, TX 75063 /
1777 Phoenix Parkway, Suite 201, Atlanta, GA 30349
ICOM CANADA, A Division of ICOM America, Inc.,
3071 - #5 Road, Unit 9, Richmond, B.C. V6X 2T4 Canada

All stated specifications are subject to change without notice or obligation. All ICOM radios significantly exceed FCC regulations limiting spurious emissions. 9000489

POP'COMM's World Band Tuning Tips

April, 1991

This Pop'Comm feature is designed to help you hear more shortwave stations. Each month, this handy, pull-out guide will show you when and where to tune to hear a wide variety of local and international broadcasters.

The list includes broadcasts in many languages besides English and most of the transmissions are not beamed to North America. Keep in mind that stations make frequent changes in their broadcast times and frequencies. Changes in propagation conditions may also make some stations difficult or impossible to receive. Your own equipment and receiving location will also have a bearing on what stations you are able to hear.

Note: EE, SS, FF, etc. are abbreviations for English, Spanish, French, etc. All times are in UTC.

Freq.	Station/Country	UTC	Notes	Freq.	Station/Country	UTC	Notes
2390	R. Huayacocotla, Mexico	0000	SS to 0100-close	6135	R. Universidad, Chile	1000	SS, sign on
3200	Trans World Radio, Swaziland	0400	sign on	6140	ABC, Australia	1130	
3220	HCJB, Ecuador	eves	SS, Quechua	6140	R. Havana Cuba	0300	
3260	R. Madang, PNG	1200	Pidgin	6150	Vatican Radio	0100	
3270	R. Namibia	0400	vernaculars	6150	Caracol Neiva, Colombia	eves	SS
3370	R. Tezulutlan, Guatemala	0030	SS	6160	CKZN, Canada	1230	relay CBN
3985	Swiss R. Int'l	0600	sign on	6165	R. Netherlands	0100	via Bonairz
4000	R. Bafoussam, Cameroon	0430	sign on, FF	6175	R. France Int'l	0500	FF
4635	Tadzhik Radio, USSR	0045	RR	6185	R. Educacion, Mexico	0430	SS
4680	R. Nac. Espejo, Ecuador	eves	SS, irregular	6210	European Christian R., Italy	0700	sign on
4750	R. Bertoua, Cameroon	2200	FF	6205	HCJB, Ecuador	0600	
4760	Yunnan PBS, China	1200	CC	6248	Vatican Radio	0630	
4780	RTV Jibouti	0300	FF, sign on	6305	LV del CID	0400	SS, Cuban clandestine
4780	LV de Carabobo, Venezuela	eves	SS	6400	V of the Strait, China	1130	CC to Taiwan
4815	RTV Bourkina, Burkina-Faso	0700	FF, sign on	6540	R. Pyongyang, N. Korea	1200	JJ
4830	R. Tachira, Venezuela	eves	SS	6550	V of Lebanon	0530	
4845	R. K'ekchi', Guatemala	0130	SS, indian	6900	V of Meterology, Turkey	0500	TT
4875	Voice of Jinling, China	1230	CC	7105	Trans World Radio, Monaco	0700	
4920	ABC, Australia	1200		7100	V of Ethiopia	0330	sign on, Amharic
4930	R. Barahona, Dom. Rep.	0100	SS	7115	R. Moscow	eves	
4940	RTV Ivoirienne, Iv. Coast	0600	FF, sign on	7145	R. Polonia, Poland	0130	Polish
4985	R. Brazil Central, Brazil	eves	PP	7145	R. Liberty, Germany	0200	RR
5040	LV de Nahauala, Guatemala	eves	SS, indian	7189v	R. Africa, Eq. Guinea	2130	EE religion
5045	R. Clube do Para, Brazil	eves	PP	7200	R. Mogadishu, Somalia	0300	Sign on, Somali
5075	Caracol Bogota, Colombia	eves	SS	7205	R. Australia	1200	
5268	R. Moundou, Chad	0455	FF, sign on	7230	R. Canada Int'l	0230	RR, via Portugal
5905	R. Moscow	0100	SS	7230	R. Suid Africa, S. Africa	0400	sign on
5930	R. Prague, Czechoslovakia	eves	EE, others	7240	R. Garoua, Cameroon	0700	Sign on, FF
5960	R. Canada Int'l	0000		7270	R. Polonia, Poland	0100	Polish
5975	BBC	eves	via Antigua relay	7285	RTM, Mali	0700	sign on, FF
5980	R. Guaruja, Brazil	0100	PP	7300	R. Tirana, Albania	eves	EE/SS
5982	AWR, Union Radio, Guatemala	0300	SS	7310	R. Moscow	eves	
6000	R. Guaiba, Brazil	0130	PP	7325	BBC	eves	
6000	R. Moscow	eves		7345	R. Prague, Czechoslovakia	eves	
6010	R. Mil, Mexico	eves	SS, irregular	7375	R. For Peace Int'l, C. Rica	eves	EE/SSB
6015	R. Austria Int'l	0500	sign on, GG/EE	7440	CPBS, China	1200	CC
6020	R. Netherlands	0130		7475	RTT Tunisia	0500	AA
6025	R. Amanacer, Dom. Rep.	eves	SS	9022	VOIRI, Iran	2330	Farsi
6050	HCJB, Ecuador	eves	SS	9115	R. Continental, Argentina	2200	SS (feeder)
6060	RAE, Argentina	0000	SS	9360	Spanish N'l Radio	0300	SS
6065	R. Super, Colombia	eves	SS	9410	BBC	2200	
6070	CFRX, Canada	eves	CFRB relay	9425	V of Greece	0400	Greek
6085	Deutsche Welle, Germany	0400		9435	V of Israel	0000	
6090	R. Luxembourg	2300		9445	V of Turkey	0000	Turkish
6105	XEQM, Mexico	1200	SS, irregular	9455	V of America	0100	
6115v	R. Union, Peru	0430	SS	9475	R. Cairo, Egypt	0200	EE
6120	R. Japan	1100	via Canada				

Freq.	Station/Country	UTC	Notes	Freq.	Station/Country	UTC	Notes
9485	Trans World Radio, Monaco	0630	sign on	12000	R. Moscow	0100	
9500	R. Tirana, Albania	0100		12035	Swiss R. Int'l	0130	
9505	R. Japan	1300		12045	V of Greece	1800	
9510	R. Romania Int'l	0200	EE	12050	R. Cairo, Egypt	2100	
9515	R. Novas de Paz, Brazil	2030	PP	12085	R. Damascus, Syria	1830	
9525	R. Havana Cuba	0600		12120	CPBS, China	1200	CC
9525	R. Marti, USA	0100	SS	12200	CPBS, China	0030	CC
9530	KHBI, Saipan	1400		12300	Voice of Unity	1530	Anti-Afghanistan
9535	Trans World Radio, Bonaire	0300		13620	R. Baghdad	2330	AA
9545	Deutsche Welle, Germany	0300		13645	R. Kiev, Ukraine	0030	
9545	Solomon Is. Bc Corp	0700		13675	R. Pakistan	1330	
9555	La Hora Exacta, Mexico	1300	SS	13680	R. Baghdad	2230	AA
9575	RAI, Italy	0100		13695	WYFR, USA	0100	
9580	R. Australia	mornings		13715	R. Prague, Czechoslovakia	0100	
9585	R. Excelsior, Brazil	0100	PP	13720	Adventist World R., Guam	1200	
9590	R. Netherlands	0230		13730	R. Austria Int'l	0000	
9600	R. MEC, Brazil	2300	PP	13770	R. Netherlands	1430	
9600	R. Portugal	0130		13775	V of America	1200	
9615	R. Norway	0000	NN	13785	R. Moscow	0200	
9630	Spanish National Radio	0000		15010	V of Vietnam	1130	
9640	Ecos del Torbes, Venezuela	0100	SS	15055	V of Turkey	2230	irregular
9645	R. Veritas, Philippines	1200		15060	BSKSA, Saudi Arabia	1800	AA
9650	R. Norway Int'l	0300	NN	15070	BC	1600	
9650	Vatican Radio	0130		15095	R. Damascus, Syria	2100	
9660	ABC, Australia	1130		15100	R. Beijing, China	0100	SS
9675	R. Cancao Nova, Brazil	0100	PP	15110	R. Sofia, Bulgaria	0100	SS
9675	R. Cairo, Egypt	0200		15110	Spanish National R.	0000	
9690	RAE, Argentina	0030		15115	HCJB, Ecuador	1200	
9695	R. Sweden	0000		15125	R. Beijing, China	1200	
9705	R. Nacional, Brazil	0100	PP	15130	V of Free China, Taiwan	0030	CC, via WYFR
9715	HCJB, Ecuador	1130		15140	R. Nacional, Chile	1930	SS
9715	R. Netherlands	1200		15145	WINB, USA	0200	
9720	R. Yugoslavia	2100		15150	R. Canada Int'l	2130	
9735	R. Oman	0400	AA	15150	R. New Zealand	0530	
9735	R. Nacional, Paraguay	2300	SS	15155	HCJB, Ecuador	0100	
9750	R. Korea, S. Korea	1200		15160	LV America Latina, Mexico	2200	SS, irregular
9750	R. Minería, Chile	1000	SS	15170	R. Tahiti	0400	FF
9765	R. Kiev, Ukraine	2300		15195	R. Bangladesh	1230	
9790	R. France Int'l	0100	FF	15215	V of Free China, Taiwan	0100	CC via WYFR
9805	R. Cairo, Egypt	0300	AA	15235	R. Jamahiriyah, Libya	0300	AA
9820	Trans World Radio, Guam	1200	Asian langs.	15260	R. Canada Int'l	1800	
9835	R. Budapest, Hungary	0100		15260	BBC	2000	via Ascension
9875	R. Austria Int'l	0200		15280	KGEI, USA	0100	SS
9910	All India Radio	0030		15290	R. Sofia, Bulgaria	0300	
9925	BRT, Belgium	0000		15295	V of Malaysia	1230	
11550	RTT Tunisia	0245	AA	15300	R. France Int'l	1900	FF
11605	V of Israel	0000		15300	R. Japan	1200	
11645	V of Greece	2300	Greek	15300	UAE Radio, UAE	2000	AA
11660	R. Sofia, Bulgaria	0300		15310	R. Norway Int'l	1500	
11670	R. France Int'l	2245		15330	RTV Marocaine, Morocco	2000	AA
11685	R. Prague, Czechoslovakia	0000		15335	All India Radio	1400	
11695	KUSW, USA	0200		15345	RAE, Argentina	2200	
11705	R. Sweden	0000		15345	V of Free China, Taiwan	2200	via WYFR
11710	RAE, Argentina	0200		15360	R. Moscow	1200	Asian langs.
11715	R. Beijing	0300	via Mali	15375	R. Cairo, Egypt	2030	
11720	R. Canada Int'l	1400		15400	R. Finland Int'l	1200	
11725	R. Havana Cuba	0100	SS	15495	R. Baghdad	2000	irregular
11740	V of Free China, Taiwan	0200	via WYFR	15500	CPBS, China	0945	CC
11760	R. Havana	0100	SS	15510	R. Afghanistan	1730	via USSR
11760	R. Cook Islands	0600		15540	RTBF, Belgium	1900	FF
11780	Vatican Radio	0030		15560	R. Netherlands	1830	
11785	R. Guaiba, Brazil	2300	PP	15566	WYFR, USA	eves	various langs.
11790	VOIRI, Iran	1130	Farsi, etc.	15575	R. Korea, S. Korea	1400	
11800	RAI, Italy	0100		15630	V of Greece	1800	
11815	Trans World Radio, Bonaire	1100		15650	R. Iran	0230	anti-Iran
11835	SLBC, Sri Lanka	1100		17540	V of Unity	1530	anti-Afghanistan
11835	R. El Espectador	0100	SS	17560	BRT, Belgium	1300	
11845	R. Canada Int'l	0100		17605	R. Netherlands	1330	
11850	FEBC, Philippines	1500		17610	R. Damascus, Syria	1900	
11860	R. Baghdad/V of Peace	2130		17640	R. Pakistan	1200	
11865	Deutsche Welle, Germany	0000		17675	R. New Zealand	0300	
11870	R. Lira, Costa Rica	0100		17685	R. Moscow	eves	
11800	Spanish National Radio	0100		17715	R. Beijing, China	0000	via Mali
11890	R. Oman	0400	AA, sign on	17745	R. Algiers, Algeria	2000	
11905	Deutsche Welle, Germany	0300		17770	R. Oman	0300	AA
11920	RTV Ivoirienne, Iv. Coast	2100	FF	17815	R. Cultura, Brazil	2230	PP
11925	R. Bandeirantes, Brazil	2300		17820	R. Canada Int'l	1430	
11930	R. Havana Cuba	0100		17855	R. Beijing, China	0000	
11940	R. Romania Int'l	0200		17875	QBS, Qatar	1630	AA
11945	R. Canada Int'l	2200		21450	R. Prague, Czechoslovakia	1600	
11955	R. Nacional, Angola	2130		21810	BRT, Belgium	1400	
11980	Trans World Radio, Guam	1400	KTWR	21505	BSKSA, Saudi Arabia	1630	AA
11990	R. Prague, Czechoslovakia	0100		25680	Swiss R. Int'l	1400	GG

BROADCAST DX'ING

BY ROGER STERCKX, KVT1JH

DX, NEWS AND VIEWS OF AM AND FM BROADCASTING

Exodus Report: Less than two years ago, the FCC began permitting broadcasters to relocate their stations from small towns to suburbs of large cities. Now the FCC is pulling in its horns, at least a little, on the concept.

The original idea was spurred by the thought that, even though the geographic change might not be very large, the identification of the facility with a large-city suburb would improve the station's image and chances for success than when its city of license was an isolated rural community. It would also provide the suburban areas with their own local stations, while still providing the original rural areas with substantially the same signal levels.

On second thought, however, the FCC has fears that once such stations become identified with suburbs of large cities, they will attempt to direct their programming to the large city audiences. In the process, abandoning their previous rural audiences and leaving them in a void, without local news and community interest coverage.

As a result, the FCC will still consider and allow relocations from small towns to suburbs, but the agency will be looking at each application and taking more into consideration the proposed coverage, as well as any loss of coverage the relocation will have on the community which the station wishes to move from. If the broadcaster turns out to be the sole provider of broadcast coverage to a local community, it may now have a harder time pulling up stakes and moving a few miles down the road to a more populous big city suburb.

The New AM Band: The 1605 to 1705 kHz expanded AM broadcast band is still being worked out as part of the FCC's multi-pronged proposal to pump new life into the weary AM'casting scene.

The FCC's thoughts for this band are that



The local rocker in Avon, MA is WBCN/104.1. Their bumper sticker is in white, plus yellow and several shades of blue. (Courtesy Ed Bevens, Avon, MA.)

existing AM stations should have first crack at licenses here. The idea being that this will remove numerous stations from the 535 to 1605 kHz band, and thus reduce interference by cutting down on the station load that portion of the band presently carries. The National Association of Broadcasters, generally, likes this approach and feels that it will populate the new frequencies with experienced broadcasters having established audiences.

Among those who don't like the idea is National Public Radio, which feels that the frequencies should be used for the establishment of new public radio outlets. NPR pointed out that some 14% of the population is unable to receive any public radio programming. NPR would like at least two frequencies in this band reserved for public radio use.

Another opponent of the FCC's plan is Capital Cities/ABC. They noted that the

agency's approach may do something for cutting down on nighttime interference, but it won't do anything at all for receiving problems experienced by listeners having wide-band high-fidelity receivers that pick up daytime adjacent channel interference. CC/ABC feels that this type of interference is the worst enemy of improving the quality of AM sound quality. Moreover, CC/ABC feels that, existing stations with established audiences will be unlikely to be enthusiastic about migrating to this new band.

AM/FM Duplication: The FCC is still favoring imposing a ban on co-owned AM/FM stations simulcasting programming. Broadcasters, in general, seem to oppose such a ban. The NAB feels that such a ban would violate the broadcasters' rights to free speech. CBS, Inc. also opposes a ban on AM/FM simulcasting, pointing out that it would cause some stations with marginal financial status to either cut back on broad-

Requests Filed For Changed FM Callsigns

Present	Seeking	
KAPH	KTCM	Kingman, KS
KOZN	KBCD	Imperial, CA
KTIM-FM	KRDS-FM	Wickenburg, AZ
KYKM	KALK	Winfield, TX
WFBG-FM	WFGY	Altoona, PA

Requests For Changed AM Callsigns

Present	Seeking	
WPLY	WJUB	Plymouth, WI
WYOR	WYYW	Brentwood, TN

Request Withdrawn For FM Callsign

Present	Wanted	
(New)	WXSE	Calhoun, TN

AM Callsign Changes Approved

New	Former	
KCNR	KLZX	Salt Lake City, UT
KEYF	KFVR	Dishman, WA
KKCS	KWES	Colorado Springs, CO
KKSO	KJJY	Des Moines, IA
WAVJ	WONO	Black Mountain, NC
WFXA	WNTA	Augusta, GA
WGAB	WJJN	Newburg, IN
WHBT	WBGM	Tallahassee, FL
WLKW	WWAZ	Providence, RI
WPNT	WXEZ	Chicago, IL
WRJL	WHZI	Hanceville, AL
WTKZ	WINX	Rockville, MD
WVTI	WRXK	N. Ft. Myers, FL
WWGZ	WDEY	Lapeer, MI

Applications For AM Facility Changes

KARI	Blaine, WA	550 kHz	Increase days to 25 kW.
KIST	Santa Barbara, CA	1340 kHz	Drop to 675 watts.
WCCC	Hartford, CT	1290 kHz	Drop to 490 watts, move to W. Hartford.
WIZO	Franklin, TN	1380 kHz	Drop nites to 250 watts.

Applications For FM Facility Changes

KIHX-FM	Prescott Valley, AZ	106.3 MHz	Move to Prescott, 106.7 MHz.
KSSA-FM	McKinney, TX	106.9 MHz	Move to 95.3 MHz, 3.9 kW.
WGXM	Dayton, OH	97.1 MHz	Move to 98.1 MHz.
WOBC-FM	Oberlin, OH	91.5 MHz	Move to 88.3 MHz, 3.5 kW.
WTMG	Tallahassee, FL	95.9 MHz	Move to 96.9 MHz, 50 kW.
WTJT	Crestview, FL	90.1 MHz	Move to Baker, FL.
WVGN	Charlotte Amalie, VI	107.1 MHz	Move to 105.3 MHz, 32.3 kW.
WVID	Anasco, PR	90.3 MHz	Move to 90.1 MHz.

FM Facility Changes Approved

KDDR-FM	Oakes, ND	92.3 MHz	Move to 92.5 MHz.
KTSR	College Station, TX	92.1 MHz	Move to 107.3 MHz, 25 kW.
KURO	Huron, SD	92.1 MHz	Move to 99.1 MHz.
WJNA	Churchville, VA	106.7 MHz	Move to 106.3 MHz, 25 kW.
WMTZ	Martinez, GA	94.3 MHz	Move to 93.9 MHz, 25 kW.
WSEK	Somerset, KY	96.7 MHz	Move to 97.1, 27.5 kW.
WTPC	Elsah, IL	89.7 MHz	Move to 105.3 MHz.

AM Facility Changes Approved

KIJN	Farwell, TX	1060 kHz	Increase to 5 kW.
KIPA	Hilo, HI	620 kHz	Increase synchronized xmtr to 10 kW.
WEDE	Eden, NC	830 kHz	Increase days to 50 kW.
WZGO	Portage, PA	1470 kHz	Drop to 466/88 watts.



KGRX/100.3 is in Las Vegas, NV. (Courtesy Cam Archbold, Las Vegas, NV.)

casting hours, or else go dark altogether. CBS noted, in defense of simulcasting, that co-owned AM/FM outlets often provide programming to different service areas since their signal patterns may differ considerably. Dropping simulcasting would therefore deny programming to persons that would have otherwise been able to hear it.

The flip side of the argument comes from Westinghouse Broadcasting, which supports a simulcasting ban. They feel that it would weed out marginal AM stations and force them off the air. This, they claim, will reduce interference in the AM band.

Application For New AM Station

GA	Baxley	590 kHz	316 Watts
----	--------	---------	-----------

Applications For New FM Stations

AR	Jonesboro	93.9 MHz	6 kW
AZ	Parker	99.3 MHz	18 kW
CA	Kings Beach	89.9 MHz	3 kW
CA	Shafter	90.9 MHz	50 kW
FL	Tavernier	96.9 MHz	8 kW
IA	Stuart	107.9 MHz	6 kW
KS	Minneapolis	92.7 MHz	
KS	Topeka	89.9 MHz	1 kW
MN	Rushford	99.3 MHz	6 kW
MO	Halfway	93.1 MHz	2 kW
MT	Bozeman	99.9 MHz	100 kW
NM	Roswell	104.7 MHz	50 kW
OH	Chillicothe	91.9 MHz	1 kW
OH	New Philadelphia	91.5 MHz	1 kW
OR	Medford	91.7 MHz	1 kW
TN	Cookeville	90.9 MHz	20 kW
TN	Cordova	93.9 MHz	3 kW
TX	Lubbock	90.9 MHz	5 kW
TX	New Braunfels	89.9 MHz	7 kW
WA	Chehalis	90.5 MHz	3 kW
WV	Lost Creek	96.3 MHz	3 kW

Permit Granted For New AM Station

NC	Paw Creek	820 kHz
----	-----------	---------

Permits Granted For New FM Stations

AR	Clarendon	107.3 MHz	3 kW
CA	Essex	98.9 MHz	7 kW
CA	Ione	88.3 MHz	2 kW
CA	Morro Bay	99.7 MHz	450 watts
CA	Quincy	100.3 MHz	3 kW
CO	Brush	106.3 MHz	3 kW
FL	Cedar Key	102.7 MHz	3 kW
FL	Key West	107.9 kHz	100 kW
FL	Silver Springs	95.5 MHz	3 kW
GA	Jeffersonville	97.5 MHz	3 kW
IL	Spring Valley	103.3 MHz	3 kW
IN	Bremen	96.9 MHz	3 kW
IN	Ligonier	102.7 MHz	3 kW
KS	Kerington	96.3 MHz	3 kW
MO	Poplar Bluff	103.5 MHz	50 kW
MO	Potosi	97.7 MHz	6 kW
MS	Kosciusko	103.3 MHz	25 kW
NC	Rose Hill	104.7 MHz	3 kW
NH	Winchester	98.7 MHz	3 kW
OH	W. Carrollton	92.1 MHz	3 kW
OR	Eugene	88.1 MHz	500 watts
PA	Montaintop	97.1 MHz	250 watts
PA	Slippery Rock	88.1 MHz	1 kW
RI	Block Island	95.9 MHz	3 kW
SD	Canton	102.5 MHz	3 kW
SD	Martin	102.5 MHz	100 kW
TN	Memphis	89.3 MHz	3 kW
TX	Huntsville	94.9 MHz	3 kW
VA	Bedford	106.9 MHz	181 watts
VA	Vinton	106.1 MHz	3 kW
WY	Ft. Bridger	99.3 MHz	3 kW

A Little DAB'll Do Ya: The question of where to locate Digital Audio Broadcasting (DAB) frequencies remains to be settled. Proposals for 728 to 788 MHz, and 2390 to 2450 MHz are still alive, but laying in the dust, bruised and bleeding, after the clubbing they've been getting from those offering opinions. At the present time, 1493 to 1525 MHz looks to be the best possibility, if for no better reason than the band has attracted the least amount of hostile reaction.

One of the shadows cast on the selection is that frequency-hungry High Definition TV (HDTV) is also on the horizon and sniffing around for frequency space. It's sure to cause a lively debate at the ITU's World Administrative Radio Conference (WARC), to be held next year in Spain.

UHF-T Band Doings: When land mobile communications frequencies began getting in short supply around several metro areas, the FCC set aside UHF-TV channels 14 through 20 for two-way use only in those specific areas. This became the so-called UHF-T (for TV) 470 to 512 MHz scanner band. In areas beyond those few metro zones set aside for this type of use, normal UHF TV operations take place and the FCC does not issue land-mobile two way authorizations so the two types of usages will not interfere with one another.

However, the Association for Maximum Service Television recently complained to the FCC that the agency appears to be mix-

New FM Callsigns Issued

KCHT	Bakersfield, CA	WROU	W. Carrollton, OH
KEBR-FM	N. Highland, NC	WRSK	Slippery Rock, PA
KEDR	Ione, CA	WSMK	Buchanan, MI
KGAL-FM	Brownsville, OR	WVBI	Block Island, RI
KKRC	Granite Falls, MN	WWGO	Silver Spring, FL
KZPX	Nisswa, MN	WZXS	Topsail Beach, FL
KZPY	Los Linas, NM	WZXT	Farmington, IL
KZPZ	Lakeville, MN	WZXU	Oneonta, NY
WAIV	Spring Valley, IL	WZVX	Palmyra, NY
WBCY	Archbold, OH	WZYG	Ellettsville, IN
WCCG	Hope Mills, NC	WZYH	New Bern, NC
WEIB	Northampton, MA	WZYI	Point Pleasant, WV
WMJC	Bremen, IN	WZYJ	Rose Hill, NC

FM Callsign Changes Approved

New	Former			
KBUY-FM	KDJW-FM	Amarillo, TX	KZRK	KVRV
KCHQ	KPMA	Altamont, OR	WCOL-FM	WXGT
KCOZ	KSOZ	Pt. Lookout, MO	WEBZ	WLPC
KGAR	KUKU-FM	Willow Springs, MO	WFXU	WTLL
KGDN	KUKE	Pasco, WA	WHP-FM	WXBB
KIOX-FM	KXGC-FM	El Campo, TX	WKDE-FM	WKHV
KJLT-FM	KSRZ-FM	N. Platte, NE	WMTX	WNLT
KMXI	KMJK-FM	Lake Oswego, OR	WOBG-FM	WXKI
KQCS	KGLR	Betterdorf, IA	WPNT-FM	WXEZ-FM
KSEG	KROY	Sacramento, CA	WQLS	WNER
KSJZ	KSJM	Jamestown, ND	WRGI	WLAZ
KSTT-FM	KSRZ-FM	N. Platte, NE	WVZX	WXML
KTMC-FM	KZBX	McAlester, OK	WWFN	WQTR
KWES	KSUY-FM	Ruidoso, NM	WWGZ-FM	WWGZ
KZHE	KMSL	Stamps, AR	WXKT	WOKD-FM
				Cassville, MO
				Columbus, OH
				Mexico Beach, FL
				Live Oak, FL
				Harrisburg, PA
				Altavista, VA
				Clearwater, FL
				Salem, WV
				Chicago, IL
				Ozark, AL
				Naples, FL
				Sandusky, OH
				Lake City, SC
				Lapeer, MI
				Arcadia, FL

SCORPIO

```
ID(Sta): Radio Moscow      Location: Leningrad / USSR
Date: 10-23-90  Begin Prg: 01:30:17  End Prg:      Freq: 7.305.00
Mode: AM          Signal          App/Svc: Broadcast      QSL: S
Remarks: Contemporary Russian Music and News
Data: 230: 07/28/89 / 01:00 > 02:15 / 7.305.00 AM / Signal (59-30)  #230
[Radio] [ <-> ] [CLS]      Manual Mode      [CLD] [S/F] [Qu/eX]
-----LogScan-----[Log of John Doe-----[TJ]
```

Terminal Unit Display Window

Terminal Unit Command Window

1 ID(Sta) 2 Locatn 3 Signal 4 Agency 5 Remark 6 TimeON 7 TimeOFF 8 Clear 9 Log 10 Optns

Integrated Multi-Function Communications Software for IBM PCs

Simultaneous

■ Radio Control / Scanning

■ Log Database Management

■ TU Digital Control/Disp

- > LogScan, AutoLog and AutoTU functions > Interfaces with All Mode Terminal Units
- > Mouse/Function Key control of Kenwood & Icom Rcvrs & RS232 Digital Terminal Units
- > Search Log by any field including Remarks > Scan Receiver based on Log Search criteria
- > Copy RTTY & other DIGITAL signals > AutoTU sets TU mode as needed during scan
- > LogScan has real time UTC and FRQ. limit options > AutoLog builds database from "hits"
- > Run other programs (or DOS) from within Scorpio > Includes HF database & Manual

MasterCard \$89.95 (+ \$5.00 S&H) Visa



PO Box 830 - Dandridge, TN 37725 - (615-397-0742)
CompuServe # 72557, 3560

CIRCLE 13 ON READER SERVICE CARD

POPULAR COMMUNICATIONS

76 NORTH BROADWAY
HICKSVILLE, NEW YORK 11801

FREE READER SERVICE CARD

ENTER MONTH AND YEAR OF THIS ISSUE:

Month							Year				
-------	--	--	--	--	--	--	------	--	--	--	--

(REQUESTS CANNOT BE PROCESSED WITHOUT DATES)

1	2	3	4	5	6	7	8	9	10	11	12
13	14	15	16	17	18	19	20	21	22	23	24
25	26	27	28	29	30	31	32	33	34	35	36
37	38	39	40	41	42	43	44	45	46	47	48
49	50	51	52	53	54	55	56	57	58	59	60
61	62	63	64	65	66	67	68	69	70	71	72
73	74	75	76	77	78	79	80	81	82	83	84
85	86	87	88	89	90	91	92	93	94	95	96
97	98	99	100	101	102	103	104	105	106	107	108
109	110	111	112	113	114	115	116	117	118	119	120
121	122	123	124	125	126	127	128	129	130	131	132
133	134	135	136	137	138	139	140	141	142	143	144
145	146	147	148	149	150	151	152	153	154	155	156
157	158	159	160	161	162	163	164	165	166	167	168
169	170	171	172	173	174	175	176	177	178	179	180

Did you purchase this issue of Popular Communications from either a newsstand or magazine store? Yes No

Name _____
 Company Name _____
 Address _____
 City _____ State _____ Zip _____



If you can't get a bumper sticker, here's the next best thing—a photo of the station's billboard! The KOOL billboard was snapped in Phoenix, AZ. (Courtesy Ryan J. Lughermo, Midland, MI.)

ing the stations, anyway. Specifically, South Bend, IN has a TV station (WNDU-TV) on TV Channel 16 (482 to 488 MHz). South Bend is therefore not a metro area where FCC regulations permit UHF-T band land-mobile services. Yet, the AMSA observes that they have learned that the FCC has, in apparent conflict with its own regulations, licensed eight land-mobile two-way systems in the South Bend area.

AMSA seeks an internal FCC investigation to learn why land-mobile licenses were issued in that area, and if similar UHF-T band two-way licenses have also been issued in other areas where only telecasting is permitted between 470 and 512 MHz.

Move For The Better?: Mark F. Henning, Hamburg, NY complains to us that CJFT/530, Fort Erie, Ontario decided that their future lies in the area of FM rather than AM radio. That means, adios 530 kHz, hello 101.1 FM. Mark tells us that CJFT feels that FM offers them more signal quality and reliability, although he says their AM signal always had no problem reaching well into western New York State, and even had good coverage into Pennsylvania. He doubts that FM will duplicate that coverage, and he figures many who enjoy listening to the oldies on CJFT will no longer be able to copy the signal.

Mark mentions that last November there were some great DX experiments that he'd like to see repeated. WSYB/1380, Rutland, VT was received at midnight, with traces of WARU/1600 and others. These stations were all on running full power with non-directional antennas to see what kind of coverage they could get. He said it was a fun way to log new stations and he'd like to encourage more stations to give it a try.

Sounds of Silence: A letter from Keith Short, Registered Monitor KOH8KY, of Columbus, OH passes along the sad news of the loss of WBBY, 103.9 MHz. This was

The Best* Just Got Better!

The Eavesdroppers™ now includes our new Zap Trapper™ Electronic Gas Tube Lightning Arrestors. Receive-only design shunts damaging transients to ground at only 1/7th the voltage buildup of the available 200 watt transmit-type arrestors, providing maximum solid state receiver protection.

Protect your investment - combine an excellent shortwave receiving antenna with the best receiver protection money can buy.



- Completely assembled and ready to use
 - Only 42' overall length
 - 8 trap circuits permit reception on all shortwave bands, 11-90 meters
 - All connections soldered and enclosed in ultrasonically-welded, hermetically-sealed trap covers
 - Includes 50' of 450 lb. test nylon rope
- Model T** includes 100' twinlead feedline
- Model C** includes weatherproofed center connector for your coax & coax sealant
- Either model \$79.95
 - UPS for lower 48 states \$4.00
 - COD add \$3.00, IL add 7% sales tax
 - Foreign shipping quoted

*"The best...built like an antenna should be." -Larry Magne in *World Radio TV Handbook*

"Our best seller." -EEB in their recent ads and catalogs

"Now in use in 45 countries." -Gilfer Shortwave in 1983

Antenna Supermarket

PO. Box 563 Palatine, IL 60078 Tel (708) 359-7092 Fax (708) 359-8161

At your dealer or direct • Visa & Mastercard accepted

Order Back Issues of

POPULAR COMMUNICATIONS

one of the few stations in the nation that played jazz, full time.

The FCC decided not to renew WBBY's license, after a lengthy (ten year) battle waged by WBBY to remain a licensee. The station tried every possible avenue, but nothing worked. Twenty employees had to be let go, including eleven air personalities.

The *Columbus Dispatch* reported that WBBY was owned by Carl Nourse, who also owns a Chevy dealership. The FCC, the newspaper reported, "prefers stations licensed to and operated by full-time or direct family management," according to information from station officials and FCC documents. WBBY's last day was December 31st, 1990. A sorry, and totally needless, loss to broadcasting of a station that was effectively providing a worthwhile service to the public, but got strangled by red tape, and buried under regulations of questionable value. R.I.P., WBBY!

Tally Time: At the end of last year, the FCC claimed that there were 4,984 AM broadcasters, 4,372 commercial FM stations, 1,438 non-commercial FM stations, 1,863 FM translators and boosters. TV had

1,115 VHF/UHF commercial stations, 354 non-commercial stations, 4,962 VHF/UHF translators, and 779 VHF/UHF LPTV stations.

Stuck on Stickers: Lots of radio folk collect and swap broadcasting station bumper stickers. Cam Archbold (who's on the air over KGRX/100.3) is an avid swapper. He tells us that he'd like to be in contact with others who'd like to trade stickers. He likes to have a pair of stickers (that is, two of them) from each station, and will return two in trade. Contact him at: Cam Archbold, 6120 W. Tropicana, Box A16197, Las Vegas, NV 89103.

A reader who would like to correspond with others who (like he is) are "obsessed with radio," is Ryan Lughermo, Registered Monitor KMI8HH, P.O. Box 413, Midland, MI 48640-0413. Ryan sent us some excellent stickers, also some station photos that he's taken during his travels.

We'd also like to hear from you here at the column! Send along AM/FM station photos, bumper stickers, recent QSL's, news clippings, comments, questions, and anything else relating to broadcasting. ■

How To Install A VHF/UHF Mobile Remote

Manufacturers of VHF/UHF FM ham sets have now made it easier for the emergency communicator to find a spot on where to mount the set. Digital logic circuits now allow the head of the transceiver to be separate from the body of the radio, and a multi-conductor cable lets you put the head just about anywhere, and the radio tucked under a seat, or deep inside a cabinet at your command center.

Here's a listing of transceivers with remote-head option (with optional cost of remote kit): Alinco DR-590 VHF/UHF twin-band mobile (\$29); Standard Radio C5600 with full-remote mike control (mike included); ICOM IC-901 and IC-900 multi-band FM transceiver (fiber optic controller included; optical fiber 65-foot extension, \$74.99); Kenwood TM-701A, 531A, 541A (RC-20, \$229.95; RC-10 handset, \$219; extension cable kit, \$45.95); Kenwood TM-721, 731, 701, 531, and 541 with remote controller handset; Kenwood TM-941A tri-band FM transceiver (\$5.95); Yaesu FT-4700 dual-band FM mobile/base (cable kit included).

The remote control head option is ordered through the local authorized radio dealer, not from the factory. Most dealers will normally stock the remote-control cable network for immediate pick-up and delivery. Same thing with the catalog mail order ham radio dealers they usually have the remote-control cable assembly in stock, just waiting for you to buy it.

As competition among manufacturers gets hotter, expect to see more "optional remote control kits" coming as a standard feature. The original Yaesu FT-4700 was first sold without the kit, but later the kit was included at no additional charge.



ICOM IC-901A remote control package.

It takes approximately 25 minutes to strip down the front head when adding the optional (sometimes included) remote control cable. All you will need is a small Phillips screwdriver and some long-nose pliers. Once the head is off the main body of the FM transceiver, find the interconnecting plug, and carefully undo it.

Next plug in the transceiver-side of the 15 foot, remote control cable into the plug coming out of the transceiver box. Tuck it out of the way and add the protective plate to keep dirt out of the inside of your set.

Now follow the instructions and plug in the remote control cable to the separated head of your transceiver. Tuck it out of the

way, and add the protective back.

Now try the set out on your test bench. Doublecheck that it operates just like it did before, but with the head now completely free with its tethered remote cable. When you go to try it out on transmit on a temporary basis, make absolutely sure you are on low power. This will keep RF from getting into the remote-control cable line.

Once you have determined that everything is operating properly, it's time to find a location for the transceiver body. I suggest under a seat, or anywhere out of the way where it is relatively cool and the heat sinks can "breathe." This is especially important if you should use your dual-band set as a

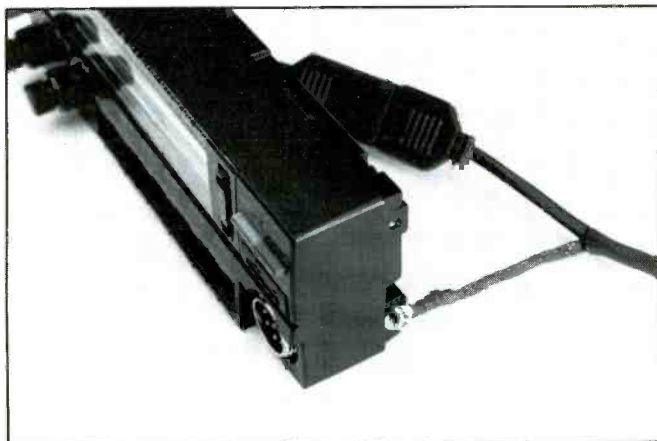

Chassis ground strap eliminates the problems of head lock-up on transmit.



ICOM IC-901A remote head installed in a fire chief's vehicle door panel.

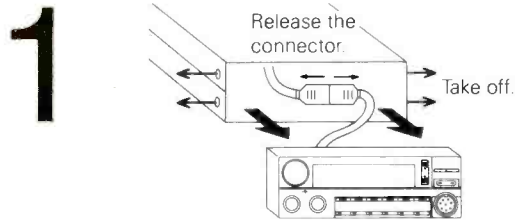

Fig. 1

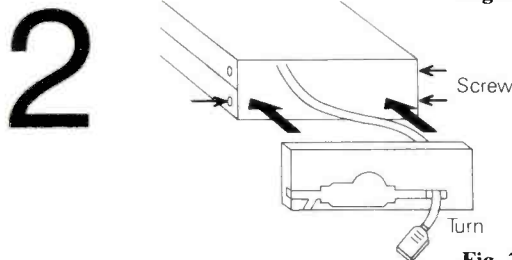

Fig. 2

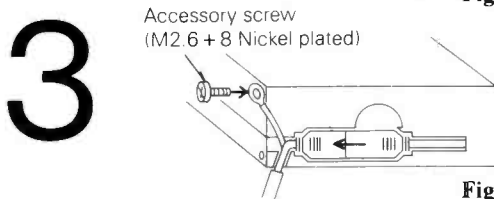

Fig. 3

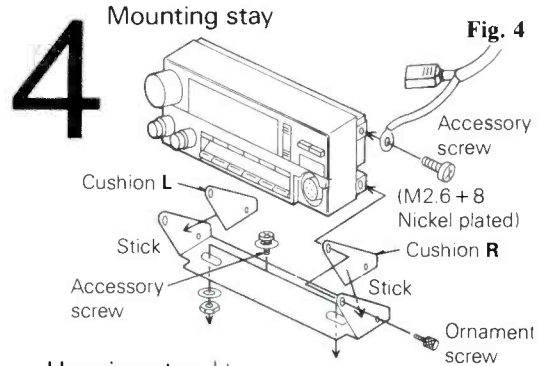
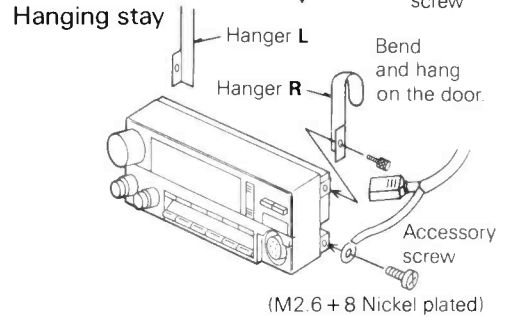

Fig. 4



It's easy to go remote with a VHF/UHF set designed for remote control.



The Alinco DR-590 easily converts over to remote control.

cross-band repeater. I don't recommend putting the transceiver body in the trunk of your vehicle. This requires too long a power lead run, and you would encounter substantial voltage drop with a 50-watt output set. Rather, anywhere within 15 feet of the battery should work out well. Don't, for a second, consider the engine compartment because that's way too warm for your transceiver set. I like under the seat as a good way to go, or behind the console on an emergency communications vehicle.

Now route the remote control cable out of sight to your "go anywhere" remote head. Put the head anywhere you want to, but make sure you can see it easily from your particular operating spot. In some cases,

you can even leave the head completely free so you can put it in your lap if you want to. However, there are some precautions if you plan to run the head independent of a secure mounting position.

What they don't tell you in the literature is that the remote head absolutely must be grounded to the frame of your vehicle with a small piece of braid. This is extremely important in order to keep RF from getting onto the remote head line and causing your set to lock-up on transmit. And if your antenna system is ground independent, such as an on-glass antenna, then you must absolutely ground the head with a thin piece of braid in order to keep your whole set-up from going into self-oscillation.

SE SIGNAL ENGINEERING's High Performance CB Antennas

SUPERHAWK
\$114.95

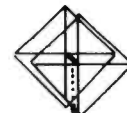

Goldenrod 45 Mobile Antenna



SPYDER A
\$35.95

WHITE LIGHTNING
\$199.95



LIGHTNING 6
\$359.95

THE most POWERFUL CB base in the world today!

All SE PATENTED rotary beams are true quads and OUTPERFORM their counter parts (quad/yagi types). SE's patented SFS matching system makes SE QUADS the most technologically advanced antennas in the world today. If your dealer doesn't have SIGNAL ENGINEERING, write or call for full specs. DEALER INQUIRIES INVITED.

SIGNAL ENGINEERING

2624 Fayette Drive, Mountain View, CA 94040
(415) 948-3833



ICOM IC-900A remote controlled multi-band VHF/UHF transceiver.

Symptoms of a remote head with the RF on the line would be an audible growl on transmit, a mike that bites you on the back of your hand from the metal clip, or in some cases the remote head suddenly blanks out as if it blew a fuse.

Guess what? On some sets, a remote head with RF feedback that blanks out will lock the transmitter up on high power output, so when you think your set is absolutely

dead, it's still putting out 50 watts. Cycle the on/off button to off, then on again, and this should correct the problem. Now you know you must absolutely ground the remote head with a short piece of braid to the metal frame of your vehicle or base ground system.

It's also possible to extend the remote-control cable network if you have an extremely long run between the remote head

and the spot where you are going to mount the transceiver box. I recently wired up an emergency communications command post with an Alinco DR-590T twin-band mobile transceiver, and I spliced 3 remote control assemblies together to give me the desired 50-foot length I needed. This would allow the operators to take the remote control head and move it from one operating position to another. At each operating position, a pigtail braid is quickly attached to the back of the remote head to insure a good RF ground. The Alinco unit worked superbly in this extended length configuration.

As transceiver mounting positions become more impossible on today's compact vehicle, a remote control head is a natural way to go. You lose absolutely no features by removing the head, and you gain the flexibility of putting the remote readout just about anywhere you want, but don't forget that little braid-tag ground strap they don't talk about in the instructions! Ground the head, and get set for crystal clear communications.

Here's a list of manufacturers of VHF/UHF remote control sets: Alinco Electronics, 348 Amapola Avenue, Suite 130, Torrance, CA 90501; Standard Radio, Heath, Benton Harbor, MI; ICOM, 2380 - 166th Avenue NE, Bellevue, WA 98004; Kenwood, PO Box 22745, Long Beach, CA 90801; Yaesu, 17210 Edwards Road, Cerritos, CA 90701. ■

HOW I GOT STARTED

We invite our readers to submit, in approximately 150 words, how they got started in the communications hobby. Each month, we'll accept them (preferably) type-written, or otherwise easily legible. If you have a photo of yourself (taken now or "then"), please include it with your story. We can't return or acknowledge material, whether or not it is used. Your story need be submitted only once, we'll keep it on file to consider it for future issues. All submissions become the property of *Popular Communications*.

Entries will be judged taking into consideration any especially interesting, unusual, or amusing aspects they contain. We reserve the right to make any editorial revisions to correct grammar, also to improve style.

The winner of the story selected will receive a 1-year subscription to *POP'COMM*, or subscription extension if already a subscriber.

Address all entries to: How I Got Started, Popular Communications, 76 North Broadway, Hicksville, NY 11801.

Our Winner For April

This month, we selected the letter written to us by George Whitmore, KB5NSY, of Truth or Consequences, NM. George wrote:

"The year was 1941. I took great delight in building my very first one-tube receiver. I turned it on. It worked. The first thing I heard on the radio was a bulletin that Pearl Harbor had been attacked and our nation was at war. My next three and a half years were spent in China with *The American Volunteer Group*.

"I flew Curtiss P-40's with the 76th Fighter Squadron, 23rd Wing of the 14th Air Force. We flew against the Japanese Zeros.

"When the war ended, my goals were to get a pilot's license and become a crop duster. That accomplished, I got married. I soon learned that flying and marriage don't always mix well. This became obvious the day I was practicing slow flight, stalls, and spins over my back yard. My wife and I decided that maybe I should get started in a different hobby.

"I recalled the fun I had building that one-



A photo of George and Betty Ann Whitmore, along with his Cessna 120. It was taken in 1949 at the Capital Airport in Springfield, IL.

tube radio and decided to head back in that direction. Soon enough, I had a ham ticket and was licensed as WA6IKV. Now, some forty five years later, I'm KB5NSY." ■

NEW PRODUCTS

REVIEW OF NEW AND INTERESTING PRODUCTS



Walker Equipment Corporation Announces A New Test Set For Phone Line Testing Near Computers – The WTS-301

Walker Equipment Corporation announced the availability of the WTS-301 telephone lineperson's test set.

The WTS-301 is a fully-featured, economical test set for use on outdoor or indoor phone lines with a water-resistant dial pad. The WTS-301 offers the additional feature of a high impedance monitor. When the phone line is being used in a data exchange, other test sets interrupt data flow because the tester impedance is too low. The WTS-301, with its high impedance monitor, is safe to use near computers that send data over phone lines because it will not interrupt data flow on telephone lines.

The WTS-301 includes a talk/monitor switch, a DTMF (tone)/pulse switch for testing of either kind of line, last number redial, an LED polarity indicator, two modular cords for flexibility to test in a variety of situations, and a cord strain relief to increase the durability of the test set. All the features are contained in the test set that weighs about twelve ounces.

Suggested price is \$135. In USA and Canada contact Walker Equipment Corp., Highway 151-South, Ringgold, GA 30736.

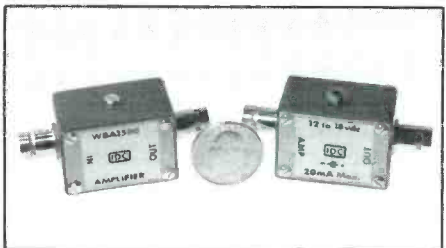

Mast Mounted Preamp

The WBA1500, introduced by IDC Communications, is a wide band mast mounted RF preamplifier designed to be used with wide band receivers, scanners, or even TV's and stereos to improve performance, and make up for long antenna cable

runs. The WBA1500 covers 2MHz through 1.5GHz. A bench type version, (WBA-1500B) is also available for frequency counters, oscilloscopes, spectrum analyzers, and related test equipment. The WBA1500 system comes complete with amplifier module, DC supply module, and AC adapter. The WBA1500 comes standard with BNC connectors, but "F" type jacks are available.

WBA1500 utilizes a state of the art low noise MMIC for the amplifier device along with surface mount devices and strip line circuitry to yield an amplifier with wide bandwidth, high gain, and low noise figure.

The WBA1500 sells for \$77.95, and the bench top model, (WBA1500B) sells for \$56.95, p.p.d. For more information write: IDC Communications, 2745 Winnetka, Ave N., Suite 205P, New Hope MN 55427, or circle 102 on our Readers' Service.

New Coaxial Connector

A 50 ohm, coaxial connector has been introduced by Pasternack Enterprises, Irvine, CA. The model PE4298, is an BNC Male, right angle, crimp type connector for RG58C/U.

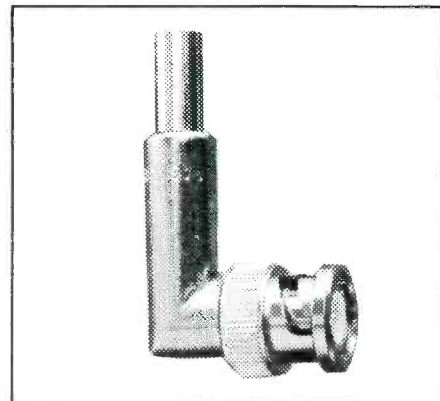

The connector has a brass nickel plated body, utilizes teflon insulation, a silver plated contact and has an operating temperature range of -65°C to $+200^{\circ}\text{C}$.

The PE4298 is designed for any RG58 that meets the requirement of Mil-C-17.

The PE4298 is priced at \$7.96 each at the 100 piece quantity. The PE4298 is only one of the many new connectors just introduced by Pasternack Enterprises.

For additional information contact: Pasternack Enterprises, PO Box 16759, Irvine, CA 92713.

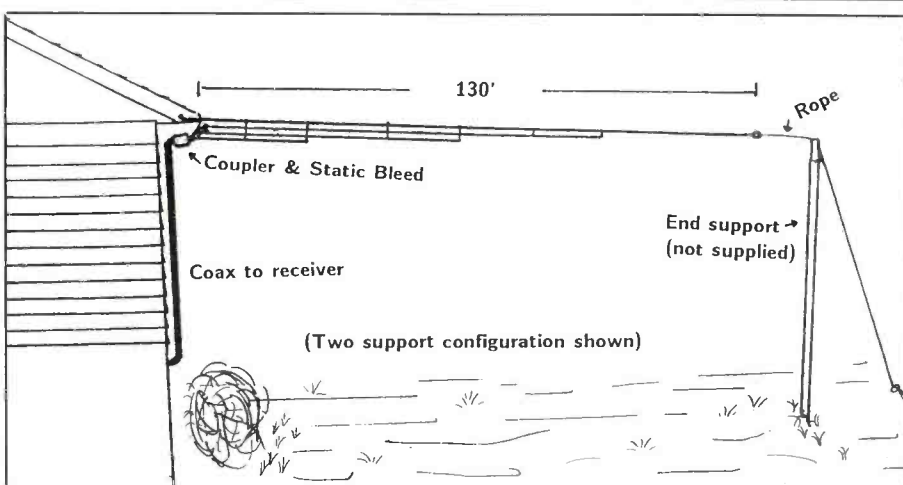

Optimized Wire Antenna Now Available

Electron Processing announced a Short-wave wire antenna for those who want optimum performance and are not limited in space. The MULTIWIRED 4 antenna at 130' long brings in signals that only a large antenna can.

The MULTIWIRED-4 covers all SWL bands from 0.5 MHz to 30 MHz and is comprised primarily of four wire elements of different lengths joined together at the feed point in a compact coupling box. The antenna can be installed in numerous configurations requiring from two to five supports. Quality com-

ponents are used throughout, and it is supplied with all hardware required for most installation. This includes 50' of coax feed-line, 100' of support rope, and a STATIC BLEED built into the coupling box. Please specify connector desired for cable end or receiver type. End supports are not included.

The MULTIWIRED-4 is priced at only \$100. For a limited time we are offering a special introductory price of \$90. There is a \$5 shipping/handling charge. To order or for additional information, contact Electron Processing, Inc. at PO Box 68, Cedar, MI 49621 or circle 103 on our Readers' Service.

27 MHz COMMUNICATIONS ACTIVITIES

The Realistic TRC-430 is a good mid-price mobile AM rig, offering several frills to make your rolling radio operation more convenient. The TRC-430 switches channels from two positions, the front panel, also the mike. When the unit is first turned on, it resets to the last channel you were using. There's an instant Channel 9 switch. It has a large green LED channel display, plus a digital S-meter/Output meter. In addition, there's a switchable noise limiter. All this in a rather tiny box, and for only \$99.95.

Look this one up at your nearest Radio Shack store as it's quite a nice transceiver.

Spectrum

In the November issue we mentioned the situation with the continuing unauthorized use of 27.410 to 27.995 MHz, above the allocated 40 CB channels, by numerous communicators in North America. We asked for comments from our readers. Comments we are receiving!

Although they are still arriving, and more will certainly be coming through for months, we have selected several that were representative enough to tell you about. We'll probably have additional comments to offer in future issues.

Bill, of New Port Richey, FL wrote to say that the November comments made it the best *CB Scene* ever. Bill has been active on the air for many years, but for the past three years he has been operating on the outbanding frequencies. He comments that he moved off the authorized channels because they became so crowded and noisy with skip chatter that he couldn't even work his mobile unit a few miles across town. He still uses the legal channels at times, but he's grown to like the "upper frequencies" and the operators he's met there.

He notes that these frequencies are host to legal AM, SSB, and FM CB-type communications in various nations around the world, even though they aren't authorized for such use in North America. He would like to see the FCC allow American stations here, and suggests the following arrangements: For a \$50 license fee, you get to run up to 100 watts, SSB and FM, with antennas limited to 20 dB gain. Transceivers to be FCC type-accepted.

From Chico, CA we heard from Maurice Picard, W6FQS, who points out that we didn't mention the numerous outbanders operating below CB Channel 1 (26.965 MHz). Also, in his area, he hears outbanders saying they're "going VHF," which means that they're heading straight for 157.20 MHz (ship transmit Channel 24 in the VHF-FM marine band), via marine transceivers. Also, he suspects that some of



Radio Shack's TRC-430 has lots of nifty features in a small package.



Adelheid, 46AT111, at the controls of the *President Lincoln*.

the comms he monitors between 46.61 and 46.97 MHz (Part 15 unlicensed FM) are outbanders running high power.

Because of these (and other) flagrant abuses of FCC regulations, plus the profanities, echo chambers, music, quarrels, and such, he questions the wisdom of any further expansion of the service. In fact, he'd prefer if the existing 27 MHz allocation was simply phased out completely and replaced with a whole new band located somewhere above 200 MHz. Still, he realizes that there are so many people dug in on 27 MHz at this point, it's probably too late for that.

Nevertheless, he pleads for some discipline and self control on the part of 27 MHz operators. Maurice points out that many public safety agencies no longer monitor any CB channels because they created such chaos that emergency communications were virtually impossible.

An outbander club, calling itself ARN, wrote (giving no return address or person's name) to say that they propose the creation of a new SSB band running from 27.415 to 27.915 MHz, 150 watts PEP, 100 ft. antenna height maximum, legal skip comms. They suggest a 30-question multiple-choice written exam, with a 70% passing score. ARN noted their club frequency is 27.525 MHz, upper side.

Those are just a sampling of thoughts, although I'd like to point out many correspondents suggested that *POP'COMM* institute a regular column devoted exclusively to outbanding. I would hold out little hope for such a column being started here.

Overseas Echos

Adelheid and Michael Schroter, of Germany, wrote to say that when the nation became unified, the restrictions against CB'er's



Michael, 46AT102, and Adelheid, 46AT-111, showing their colors at a recent CB convention in Germany. The car is a Trabant; you don't want to own one.

in their area were taken away. They, as regular readers of this column know, have been CB fans since 1982 and are now quite happy to find their hobby has been legalized. They are having a great time on the air with their new *President Lincoln* rig, and hope to come stateside for a visit next year.

Readers wishing to contact them, write to: Adelheid and Michael Schroter, P.O. Box 884, 1064 Berlin-East, Germany.

A letter from George, SSB Network member SSB-0A256, of Granbury, TX passes along news of a Dutch CB'er who is frequently heard with a powerhouse signal. That would be 11AW45, operated by Jo, whose address is Hoofdstraat 29A, 6061-CFA Posterholt, Netherlands.

George tells us that Jo's signal came bombing into Texas, practically pinning the needle for a full ten minutes! Later, George



Adelheid, 46AT111, was not at all unhappy to see the Berlin wall fall, especially since she lived east of it. That's her, over to the right, surveying the pleasant destruction.

had a chance for a landline chat with Jo and learned that he was running a Sommerkamp transceiver with a 160 watt amplifier and a quarter wave vertical antenna.

A note from DSI, P.O. Box 892, Northboro, MA 01532-0892, advises that they are a mail forwarding service for QSL cards. They suggest that operators who sign up with them can give out their QSL bureau address over the air, and then any QSL's that arrive there for them will be forwarded for a small fee. Readers interested in finding out more about this service, such as the fees and how to sign up, can contact them directly. Probably a good idea to enclose an SASE

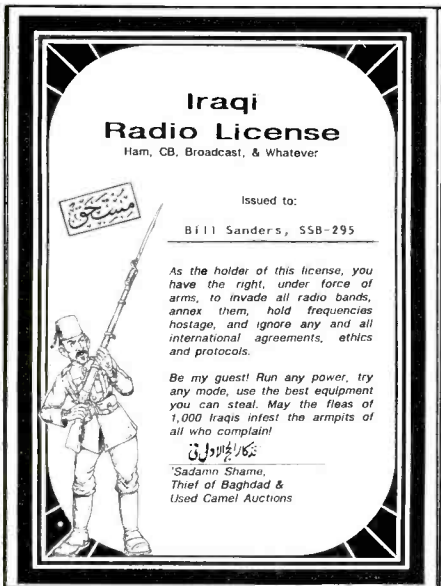

This outrageous gag "Iraqi Radio License" is printed on colored stock, suitable for hanging on your wall to amaze and amuse all visitors. It's free, too! See text for how to get yours. Mention "CB Scene" and they'll send you two, one for you, and one to give the first friend who asks you for yours.



This 11AW45 card came through from Jo, in the Netherlands. It was submitted by George, SSB-0A256, of Texas.

with your request for information. However, be aware that we here are unable to confirm the reliability of the service they described to us. You're on your own.

Networking

We hear from Eddy Methot, SSB Network member SSB-77D, of 3 Arran, Apt. A, Campbellton, New Brunswick, Canada E0K 1B0, that he's organized a local area sideband net every evening at 10 p.m. (Atlantic Time) on the upper side of Channel 25 (27.255 MHz). The local operation there is known as the North Shore Sidebanders' Group, and all within range are invited to check in.

Gary, 4S341, of Texarkana, TX hangs out on the lower side of Channel 40

(27.405 MHz). He recalls how, back in the 1970's, if you had an old 23-ch. CB rig, Channel 16 was where you went to hook up with other sidebanders. But that was the only channel that sidebanders seemed to be able to use. We remember. How happy we are that those days are history.

Here's One You'll Want

I don't know if you've yet gotten one of these gag *Iraqi Radio Licenses*, but one came across my desk the other day and I've had lots of fun with it. Everybody that's seen it wants to know where I got it, and where they can get one.

Printed on colored stock, the "license" is quite handsome and official looking, so you can put it right up there on the wall. It covers

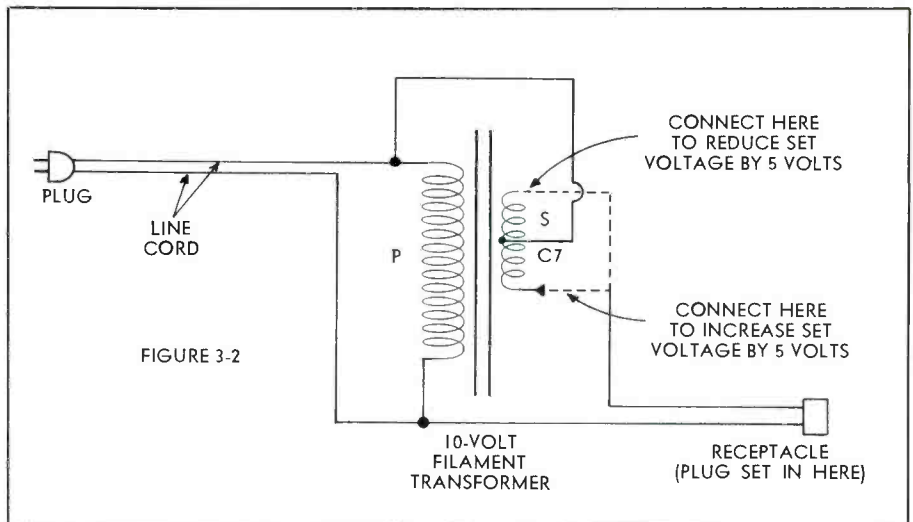

A transformer is used to raise or lower line voltage.

"Ham, CB, Broadcasting, & Whatever," and grants the holder of the license the right "under force of arms, to invade all radio bands, annex them, hold frequencies hostage, etc., etc." Further, it authorizes you to "run any power, try any mode, use the best equipment you can steal." And, naturally, it's signed by the old Thief of Baghdad and Used Camel Auctioneer himself, 'Sadamn Shame. And, there's a great picture of one of his troops here, right on the license.

These licenses are free, except you've got to send a #10 (long) self-addressed stamped (US stamp) envelope (SASE) with your request. Request yours from CRB Research Books, Inc., P.O. Box 56-X, Commack, NY 11725. Well worth having. I understand that these are very popular with the Desert Storm personnel.

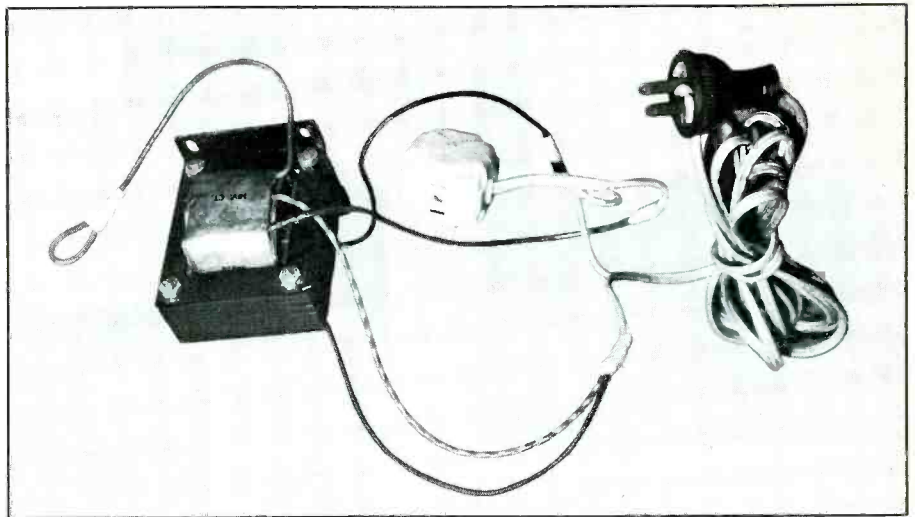

Photo of the completed transformer project.

Same Old Line

Base stations are designed to provide rated performance when the AC supply voltage is 117 VAC. Although there may be some minor variation voltage normally supplied by local utilities, should the voltage become significantly lower than 117 VAC, receiver sensitivity and transmitter power output will suffer. If the voltage goes above 117 VAC, things might improve a bit. But if the voltage goes substantially above 117 VAC, the receiver could become unstable and it will most certainly reduce component life.

If the light bulbs in your home burn out a lot, suspect that the line voltage may be on the high side. If the bulbs seem to last forever, and look a bit dimmer than they should, your line voltage could be running low. If you have an AC voltmeter offering at least 5% accuracy at full-scale, measure the line voltage. You should get a reading between 115 and 120 VAC. Or, if you suspect that your line voltage is either too high or too low, call your power utility and ask them to come over and measure the voltage.

Should you find that your line voltage is so high or low that it is affecting your communications, you can connect an autotransformer between your CB rig and the electric outlet to raise or lower the voltage. A transformer with a 10 volt center-tapped secondary can be connected as an autotransformer, as shown in the figures, to raise or lower the line voltage by 5 or 10 volts.

Let us hear from you with CB questions, comments, suggestions, activities, newspaper clippings, QSL's, and photos.

Made in USA

SOMERSET ELECTRONICS Announces... THE MICRODEC™ 'SERIES'

NOW IT'S YOUR CHOICE! You select the Model and the features to meet your decoding and budget needs*! Each choice is fully upgradeable to the top of the line! With our new VIP50 Interface you can choose an expanded display (32x16 characters on your television) and hard copy -- with or without a computer!

Prices Plus Shipping/Handling

FEATURES:	MD100 BASIC List: \$229.95	MD200 PLUS List: \$329.95	MD300 MAXIM List: \$429.95*
(Compact Size: 1.3Hx5.1Wx3.5D)			
MORSE: DECODES CW WITH			
Autospeed, software filter, speed display	★	★	★
RTTY (60,67,75, 100 WPM) (major shifts)	★	★	★
RTTY (bit inversion)		★	★
ASCII (110 & 300 BAUD)	★	★	★
ASCII (bit inversion)		★	★
AMTOR/SITOR Mode A-ARQ		★	★
AMTOR/SITOR Mode B-FEC		★	★
WEFAX (with VIP50)		★	★
Smart display/Intensity control	★	★	★
On/Off with volume	★	★	★
Serial Interface	★	★	★
Code Oscillator	★	★	★

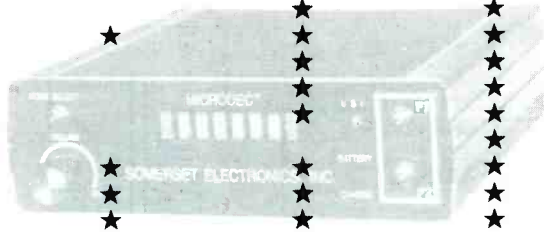

AVAILABLE OPTIONS:

Display Colors: (Green standard--no charge) Red, or Yellow (your choice) \$15.00
 NICAD Batteries for portability \$29.95 Model VIP50 Adaptor \$159.95*
 *MD300 price includes the VIP50 Interface Adaptor.

(TV Stations, phone companies, and public utilities are selecting MICRODEC™ for their operational and FCC requirements - FCC Docket 86-337.)

Call us for special introductory prices and orders at 1-800-678-7388.

Fax orders: 1-407-773-8097 • Technical assistance: 1-407-773-8097

VISA • MASTERCARD • PERSONAL CHECKS • MONEY ORDERS

SOMERSET ELECTRONICS, INC. • 1290 Hwy. A1A, Satellite Bch., FL 32937

See You At Dayton Booth #622

YOU AIN'T HEARD NOTHIN...YET!

Since 1967, CRB Research has been the world's leading publisher and supplier of unique hobby and professional books and information including:

- Scanner Frequency Guides
- Shortwave Frequency Guides
- Military/Federal Communications
- Broadcast Station Registries
- Undercover Communications
- Survival Communications
- Covert Operations
- Electronic Espionage
- Surveillance
- Monitoring
- Cryptography & Codes
- Bugging
- Wiretapping
- Communications Antennas
- Electronics & Projects
- Computer Technology
- & Other Related Topics!

Ask For Big Free Catalog!

CRB RESEARCH

P.O. Box 56 Commack, NY 11725

FOCUS ON FREE RADIO BROADCASTING

A group calling itself "DSI" has established a pirate station maildrop at PO Box 892, Dept. FB, Northboro, MA 01532-0892. DSI says it will send an up-to-date listing of all stations using that address upon receipt of a \$1.00. DSI is offering its services to any interested pirate operators. Contact them at the above address.

The Voice of Oz tells Karen King of Massachusetts that its inaugural broadcast was last September 3. The programming is 60's and 70's rock and "funny news and PASA's." "We try to poke some fun at the hobby, society, the government, etc.," manager Howard E. Lyon told Karen. Lyon blamed interference to the station on "wise-guy hams."

Alan Hislop, also of Massachusetts, forwarded a news item from Univision—the Spanish language cable TV network, about pirate broadcasters in Chile. Seems there are now nearly two dozen of these stations, mostly in the poor neighborhoods of Santiago and other large cities.

We have lots of loggings, as usual. **Radio Delta**, the "international service of United World Radio" was heard by Neil Schelgel in Minnesota on 7412 at 0027.

Neil also caught the **Free Radio Project** using CW on 7414 at 0049. The transmission began with a series of "V's" and then included such text as "Hello Free Radio Listeners," "Radio is good food," "Good manners, good missiles, good night." Also noted by Robert Ross of Ontario on 7415 in CW and USB at 2320-2350. Address was given as 137 Prism St., Wahine, Maui, 96761.

The Voice of Oz was logged by Jim Smith in Missouri on 7415 at 0330. William T. Hassig of Illinois had them at 0300 on 7410 with rock. Ron Grams, also from Illinois, found them at 0244 on 7409 with 70's rock and a discussion on alternate radio, hellos to the "Danny Boy" pirate and Canadian bootleggers. QSL address given as PO Box 452, Wellsville, NY 14895. Bob Ross and Karen King both report QSL's from this one.

Chris London in Minnesota got a logging of **Once Voice Radio** at 2218 on 15050 with readings from medical books (the station's format is health information). Chris received a quick QSL via PO Box 109, Blue Ridge Summit, PA 17214.

Several report reception of **Midnight Radio**. Bill Burnum of Kentucky had them at 0514 on 7415 with a test and phone number (214) 777-1551. ID "This is Midnight Radio and it is open 24 hours a day." Mention of the Blue Ridge address. Bill called them and learned they use 88.5 FM and 1715, mainly on holidays. DJ's are Maxwell Silver and Mike Saunders, with LeRoy the

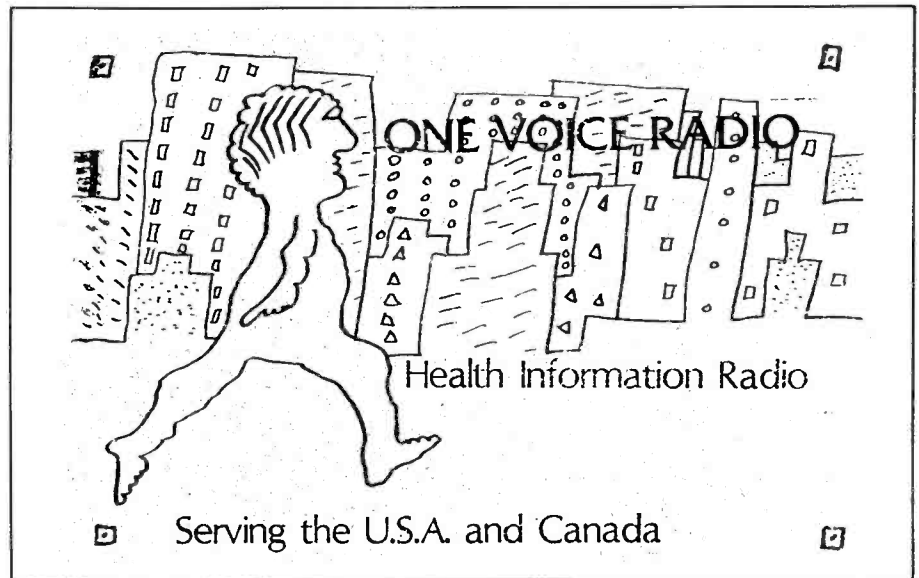

One Voice Radio devotes its program time to health information. Chris London of Minnesota gives us a look at their QSL.

janitor. Jim Smith had them at 0440 on 7410 with a talk show parody. Joshua Wilkes in Kentucky heard them at 0413. He called but got an answering machine. Joshua left his message and later got a QSL. He notes the phone is in the Dallas area and that the IS is "Big Ben" type chimes.

Joshua reports **WHDA** (We Hate Dead Air) at 0445, but forgot to give the frequency. Gave Wellsville address and claimed to be in Duckbund, MD.

KUSA - Radio Wisconsin International is another heard by Wilkes, this is on 7413 at 0300 with hard rock and a "paranoid" DJ worried about the FCC triangulation/track-down process. Claimed to be in central Wisconsin with 25 watts to a quarter wave vertical. Said he'd be back at 0500 with higher power for an "international broadcast" but this wasn't heard.

Hassig caught a rare appearance by the **Voice of Bob** on 7410 at 0520 with "esoteric, avant garde comedy skits" to 0620 sign off.

William had **WYMN** on the same frequency at 0500 on the same evening to 0505 sign off with "WYMN, where the women wear the pants, Women Radio." Bill notes that both stations had very similar signal strength and quality and wonders if the same transmitter may be used for both. Pat Murphy in Virginia had WYMN on 7410 at 0423 giving the Wellsville address. Jim Smith got them at 0425. The music on this station is all by female artists.

Ross heard **Radio USA** on 7398 at 2326 and 7395 at 0200 with punk rock, funny commercials and a Voice of Tomorrow

spoof, hosted by Mr. Blue Sky.

KBLU was logged by Burnam in Kentucky on 7415 with a mix of talk and music and offering a pirate radio bumper sticker for a self-addressed, stamped envelope. Address is PO Box 123082, Ft. Worth, Texas 76121.

Jim Smith caught **Radio Police** on 7415 at 2240 with music and an invitation to read and write to *Popular Communications*. No address for the station was announced.

Robert Ross got **P.R.N. - Pirate Radio New England** at 2310 on 7415 with a test announcement.

Jim Smith heard a station he tentatively ID's as K-Rock, on 7412.5 at 2320 playing Bob Seeger and talking about the beautiful Allegheny Mountains.

Another Ross log was **Radio Outer Limits** on 7414 at 0416 with "esoteric" rock music and ID. "You are listening to Radio Outer Limits . . . Radio Outer Limits."

Still another Robert Ross catch was **Danny Boy** 7415 LSB at 0040 with ID as "Danny Boy in PA." Attempted a QSO and then signed off.

A reminder that it is now this column's policy to avoid reporting on pirate QSO's, as such, though I'll cover any useful information you might glean from monitoring these QSO's.

Remember to let us have your pirate logs each month, as well as copies of QSL's for consideration for use as illustration. Station operators are invited to pass along information about the station—equipment, plans and so forth.

COMMUNICATIONS CONFIDENTIAL

YOUR GUIDE TO SHORTWAVE "UTILITY" STATIONS

In answer to my query for information about Mil-Spec Communications in Wakefield, RI., Paul Zecchino responded with some photos and a brief description. "We have a well equipped monitoring facility presently under contract to commercial clients. There are approximately 20 receivers for MF/HF, and several scanners. Antennas are 80'-200' longwires feeding multi-couplers. The VHF/UHF antennae are CM-5094A's. Several HF whips are also used. The grounding system is extensive, with ground leads terminated in an adjacent salt water pond. In addition to the monitoring facility, we specialize in repair of vacuum tube equipment such as R-390 and similar units. We sell reconditioned Collins equipment. We also sell other HF/MF receivers and scanners of popular manufacturers plus antennas and accessories." Thanks Paul for the rundown. I think there are many readers who would like to have an equipment installation similar to yours for monitoring.

With the collaboration of (in fact he did the lion's share of the effort), Dave White, ME and your column Editor tackled coverage of some of the sloppiest Morse code sending I have heard in a long time. One day it took well over an hour for the operator to send a short message because of constant requests from the other end for repeats of groups. In fact each time the transmitting operator sent a requested group he would repeat it differently and one group was repeated 28 times before he finally succeeded in giving it the same way twice. Dave pegged the callsign as CGN while I usually hear it as CYE, but the way the operator sends it could be completely different from both of those versions.

After many monitoring periods we finally came up with sufficient details to make an identification. It appears to be the link between the Vietnamese Embassy in Havana,

Cuba and he is believed to be working the Vietnamese Embassy in Paris, France.

It turned out that this activity was one that both Dave and I had followed several years ago, but the traffic format was somewhat different and the operators on that link were considerably easier to copy.

Here are some points which should aid in identification should you run across this particular type of traffic. The frequency is 13248 kHz and there seems to be a daily schedule normally at 1400 UTC. In the past other frequencies for similar transmissions were: 4193, 4204, 8823.9, 13240, 13251, 13279, 13281, 13870, 13909, 13965.5, 16447, 16457, 18947 and 18950 kHz.

Robert Homuth, AZ sent a note indicating he had finished his four years of college and obtained his Technician Class HAM ticket and also managed to set aside some time for SWL'ing. His main receiver is a Radio Shack DX-440 with an indoor homemade horizontal loop for HF, and a small tuned loop for longwave DX.

Preston Sewell, NJ asked about frequency designators seen in use on 11205 kHz. This is a Halifax Military (Maritime Air Group) frequency and reference was made to designator Delta One Lima and Delta One Papa. While I have some of the frequency designators utilized by this activity I do not have the above two. Do any readers have the above two frequencies?

23.4: V's in CW foll by DHO38 G33DG at 1902. Stn located West Rhaderfehn, FRG. (Tubbs, FRG)

326: Beacon PQO, Phoenix, AZ is no longer on the air. (Homuth, AZ)

329: Beacon TAD, Trinidad, CO. Easy copy at 0314. (Homuth, AZ)

338: Beacon RYN, Ryan Airport, Tuscon, AZ TWEB. Heard via groundwave w/wx bcsts parallel to ENZ, Nogales, AZ on 394 kHz. Both have moderate sigs but easy copy almost any time of the day. During nights, PBT, Proberta, CA on 338 kHz blocks our closer beacon. (Homuth, AZ)

kHz	Beacon	UTC
29060	E	1535
17015.5	S	0519
7394.5	V	1745
10643.5	S	1745
6801.5	S	1740
8645.5	S	1740
10643.5	S	1740
17015.5	S	1740
5305.5	S	1855
6801.5	S	1855
8645.5	S	1856
10643.5	S	1856
13635.5	S	1858
17015.5	S	1858
6801.5	S	1100
10643.5	S	1100
13635.5	S	1100
17015.5	S	1102
20991.5	S	1102
7394.5	V	1706
17015.5	S	1706
7394.5	V	1630

Kurt Mueller, Switzerland sent in this summary of his 1990 SLHFB logging.



Antennas on roof of Soviet Embassy, Copenhagen. Photo courtesy of Prof. Desmond Ball, Australia.

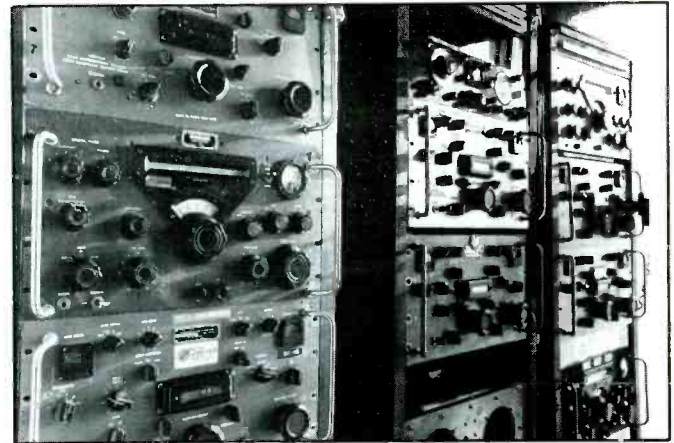
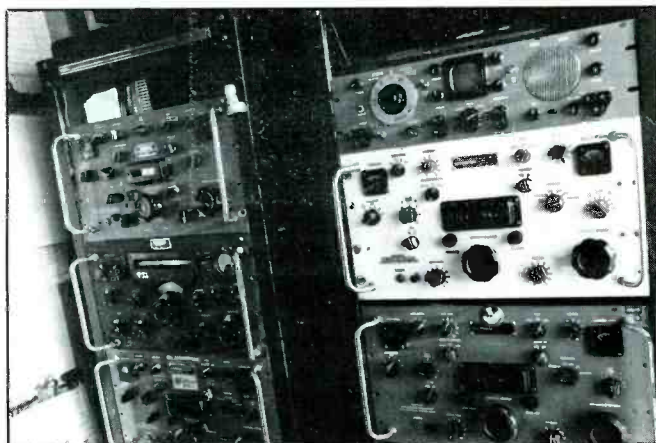

These two views show some of the monitoring equipment in use at Mil-Spec communications, Wakefield, RI.

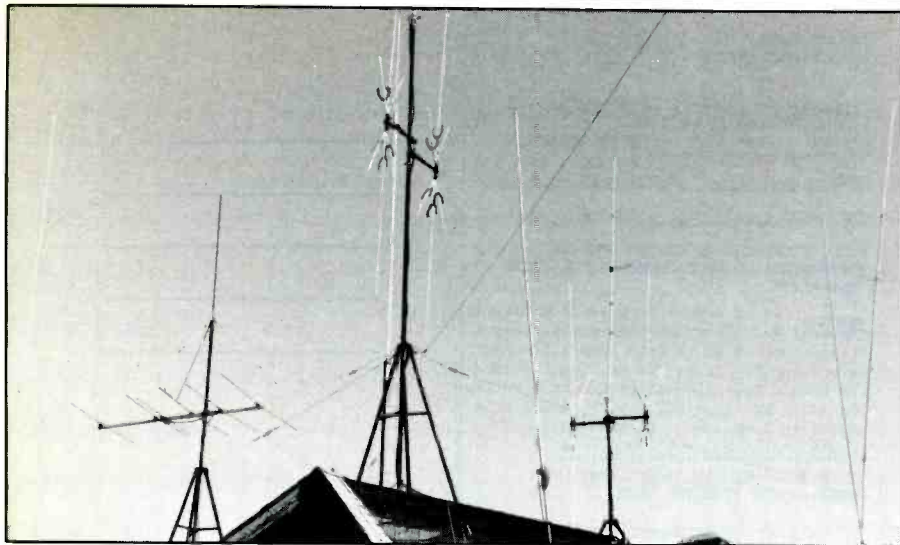

And here are some of the antennas utilized by Mil-Spec Communications for their monitoring activities.

Verification report

Airline..... BRITISH AIRWAYS

Callsign..... SEEBIRD CONCORDE 4

Aircraft Type..... CONCORDE G-BOMB
ASSAN SON

Location..... 21 4810N 10W

Frequency..... 8825

Date..... DECEMBER 6 1989

Time..... 2011
2030

Signature..... *[Handwritten Signature]*

Dick Moon, South Africa shares his PFC with readers.

- 348:** Beacon NID, China Lake NWC (Armitage Field), CA at 0603. (Homuth, AZ)
- 353:** Beacon CY, Cheyenne, WY, very weak at 0606. (Homuth, AZ)
- 357:** Beacon EGE, Eagle, CO w/ID rptd 3 times, pause, long dash. Unusual for a US beacon, but not likely an error since this beacon has had this format for quite a while. Logged at 1310, fadeout to noise. (Homuth, AZ)
- 365:** Beacon FT, Fort Worth, TX w/aviation wx for Texas and surrounding areas. MCW ID underneath AM ident. Easy to copy at 0302 fade-in. (Homuth, AZ)
- 368:** Beacon LAM, Los Alamos, NM. Weak sig at 0309 fade-in. (Homuth, AZ)
- 375:** Beacon HPL, Nucla, CO w/25 watts output. Strong & reliable signal nightly. Hrd well at 0600. (Homuth, AZ)
- 386:** Beacon SYF, Grace Flight Services NDB at St. Francis, KS. Good sigs. A 1986 QSL card from stn said they run about 50 watts. Hrd at 0600. (Homuth, AZ)
- 390:** Beacon FLR, Floresti, Romania at 0115. (Mueller, France)
- 391:** Beacon DDP, Dorado, Puerto Rico. Very strong but strong spur from TVI made this hard copy at 0327. Runs 2000 watts. (Homuth, AZ)
- 397:** Beacon SB, San Bernardino, CA. Strong at 0309. Located at Pettis AFB. runs 50w into a longwire. (Homuth, AZ)
- 399:** Beacon MTN, Salamanca/Matacan, Spain at 0125. (Mueller, France)
- 2956:** Unid CW stn at 0025 sending 5L/F grps. Used

- Spanish Nyeh (MW). Opr has typical Latino tendency to jump up to triple speed after making an error. (DP, NC)
- 3279:** Novosibirsk Volmet USSR in USB at 0223. (Edmunds, FL)
- 3380:** Rapid series of CW dots sent 2040-2045. Then YL/RR w/729 til 2050 when into 55 grp text. Later on YL announced 242 for 5 mins then into 49 grps. At 2140 sent 052 but no text. Off at 2145. (Mason, England)
- 4021:** CW stn sending NNN . . . between 0400-0405. Then YL/GG w/Gruppe 26 and into 5F grps. Also on this freq w/Gruppe 40 at 2100/2200 on Fri/Sat/Sun. (Mason, England)
- 4637.5:** KFC699, Houston, TX wkg several units in LSB at 0302. (Hill, MI) Oil rig and towboat tfc hrd this freq. (Ed.)
- 5175:** CW stn w/NNN . . . at 0600. At 0605 YL/GG w/Gruppe 22 and into 5F grps. Rptd same time next day. (Mason, England)
- 5320:** USCG Base, Fort Macon, NC wkg USCGC Point Warde WPR-82368 in USB at 0111. (Hill, MI)
- 5500:** YL/EE rptng 288 'oblique' zero zero from 2000-05 then off. On another day a CW stn was sending 971/TT during same time. (Mason, England)
- 5770:** YL rptng November Uniform w/electronic tones in background. At 2005 GG 5F text for 264 and 599. (Mason, England)
- 6200:** USS Hoist ARS40 wkg commsta Miami w/tfc in USB at 2316. Hrd only the ship's side of comms. (Hill, MI)
- 6338:** CW stn at 2325 sending call tape of 56TI DE

Abbreviations Used For Intercepts	
AM	Amplitude Modulation mode
BC	Broadcast
CW	Morse Code mode
EE	English
GG	German
ID	Identifier/location
LSB	Lower Sideband mode
OM	Male operator
PP	Portuguese
SS	Spanish
tfc	Traffic
USB	Upper Sideband mode
w/	with
wx	Weather report/forecast
YL	Female operator
4F	4-figure coded groups (i.e. 5739)
5F	5-figure coded groups
5L	5-letter coded groups (i.e. IGRXJ)

- 521JN 2/4/6 E23E. Went into tfc under hvy QRM at 2330 but did manage copy "Instituto Nacional de Meteorologi." Any ideas? (DP, NC) Probably Spain, Navy freq. (Ed.)
- 6408:** Two OM/EE in USB at 2330 discussing crew assignments for fishing vessels Liberty & Diligence for coming holidays. (DP, NC)
- 6463.5:** DE VIS3K, Sydney, NSW, Australia. CW at 1258. (Ed.)



Mobile Marine Radio, Inc. (WLO Radio)
7700 Rinta Avenue
Mobile, Alabama 36619-1199 USA

Thank you for your report of Dec 17, 1989.
WLO Radio offers a full range of marine telecommunication services to ships and rigs at sea including radiotelegraph, radioteletype, radiotelephone, and weather facsimile. WLO Radio began operation in 1947 utilizing one operator and one transmitter. Today, the station operates 7 days weekly, 24 hours daily and employs over 50 persons. The transmitters are 5kw power output built by Henry Radio. They are located at 88°12'20"W and 30°22'34"N. The antennas are directed verticals and telrex yagis. Frequencies are on 4, 6, 8, 12, 17, and 22 marine bands.

TO: Miles Hess Jr.

1-290 "FROTAHILE"! PPML

QSL from WLO sent in by Miles Hess, Jr., FL.

EMM KEMMERER MUNICIPAL AIRPORT
407 KHZ RADIO BEACON
R.C. HOMUTH, PHOENIX, AZ:
This confirms your reception 5/1/62

ANTENNA: SYMMETRICAL "T" 60' HIGH (2) 300' APART
TRANSMITTER POWER: 25 WATTS
E. R. P.: WATTS
GROUND SYSTEM:
NOTES:

SIGNATURE: *Robert C. Homuth*
AND STAMP:

Robert C. Homuth, AZ received this PFC back from a Phoenix, AZ beacon station.

6521.9: Several OM/EE in USB at 0343 w/refs to locks and tugs. Mentioned locations in Ohio and Mississippi river areas incl Vicksburg and Cincinnati. (Miles, NY)

6750: MAC 60156 (C-141) clg Lajes GCCS. Got wx then did pipe. Inbound to Mildenhall w/20,000 lb cargo, 6 pallets and 11 passengers. 0638; ROOK 77 to Croughton GCCS. Rqstd pp to Taymond 24 (Tinker AFB). Rptd airborne at 0657, ETA 1847. 0710; NOVAR 73 to Croughton GCCS. Rqstd pp to Mildenhall command post. Reported as C-130 w/18 passengers & rolling stock. ETA 0945 & wanted parking assignment & wx. 0714. All USB. (Miles, NY)

6785: WK4469 wkg WK402, chit-chat, also hrd WK403. I've hrd them here before. Who is it?? USB at 0310. (Hill, MI) No listing my Refs. (Ed.)

6789: SLHFB "V" in CW at 0242. Weak & bad QRN. Dropped 0301. (Ed.)

6811: Unid CW stn at 0050 in tfc sending 5L grps. Pauses after every 10 grps. (DP, NC)

6812: SAM 203 in USB at 1338 arranging ground arrangements thru Andrews AFB. Military personnel on board. (Edmunds, FL)

6840: YL/EE at 2300 for 14 consecutive days w/1-0 count & 245. Next fortnight w/1-0 count and 881. One night the OM/Rumanian w/5F grps after the 'Skylark' gypsy tune. (Mason, England)

8912: Sling Shot, Ping Pong, Hammer, Princess, Omaha 55, all in USB at 0355 discussing in clear Bogey coordinates, picking up an airplane drop. (Edmunds, FL)

8939: Rostov Volmet, USSR in USB at 0326. (Edmunds, FL)

8972: Blue Star, Apache, Delta 1, Stockman, Billposter, Ringleader along w/tactical callsigns. Extremely busy. Lots of encryption. Refd to Alligator Playground. (Edmunds, FL)

8993: GULL 17 clg McDill GCCS. Rqstd pp to Miami Monitor. GULL 17 asked "Wanna buy a used SATCOM system?" Was checking on msgs lost due to bad SATCOM system. Reported position south of Bermuda, they had overshoot center due to thunderstorms. USB at 0647. (Miles, NY)

9006: CanForce 5461 in USB at 0318 wkg unid stn for wx. (Hill, MI)

10780: Cape Radio w/Dodcape, Orion Bermuda and Orion Azores in USB at 2330 supporting shuttle launch. (Edmunds, FL); AFQ 376 wkg Cape Radio for pp. USB at 0326. (Hill, MI)

11176: Incredible amount of MAC tfc in USB at 0211w/Croughton, Albrook, Ascension and Adana. (Edmunds, FL); MAC 6008 in USB at 0600 clg Mainsail. Ascension GCCS answered. A/c rpstd pp to Phantom. Both a/c & Ascension having problems hearing the other. QSY'd 15015 kHz but no contact there so returned to 11176 & continued pp. (Miles, NY)

11181: OM/unid language w/4F grps. AM at 2114, very distorted. (Hill, MI)

11189: Two fishermen in LSB at 1312. Very unhappy re fine levied for not using Dolphin panels in nets. (Odd freq for fishermen?) (Edmunds, FL)

11191: Cowsmith in USB at 1630 passing tracks to Hershey. Using a line item format. (Edmunds, FL)

11387: Sydney Volmet, Australia in USB at 2103. (Edmunds, FL)

2006 CS/DOJA
APO NEW YORK 09289

THIS VERIFIES RECEPTION OF INCIRLIK
GLOBAL COMMAND AND CONTROL
SYSTEM (AIRWAYS) RADIO STATION.

DATE: 8 MAR 90 TIME: 0023Z

FREQUENCY: 11176 KHZ/USB

NOTE: DISCLOSURE OF FURTHER STATION
INFORMATION IS UNAUTHORIZED BY AIR FORCE
REGULATION.

REMARKS: It is always a pleasure to answer requests for QSL cards from our listeners. It is even better to hear from a listener from the U.S. In two years, this is only the second U.S. request that I have gotten. The first was from NH, but KY is a little closer to home. Thanks again.

Valerie J. Minchew
VALERIE J. MINCHEW, SSgt, USAF
/ CHIEF OPERATOR, GCCS

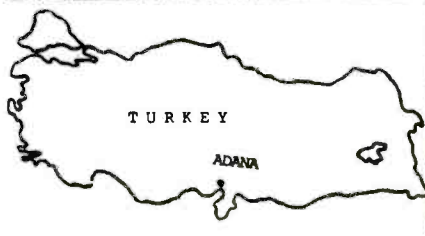
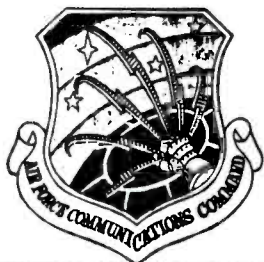

R. C. Watts, KY received this QSL from GCCS station at Incirlik.

11396: Air Canada 975 wkg NY for position & data. USB at 2225. (Hill, MI)

11545: YL rptng Juliet Whiskey w/tones in AM mode from 2100-05. Then GG 5F text for 521 and 011. (Mason, England)

12994: VVV DE VIPO4, (Perth, Australia) QSX CH 56 ET 16. CW at 1507. (Ed.)

13205: Best Idea getting positions from AF-1 via Andrews AFB. Also AF-1 made two pp's thru Royal Crown. USB at 0215. (Edmunds, FL)

13244: MAC Alpha 2268 (MAC 40651) in USB at 1630 w/pp to Charleston Command Post thru MacDill GCCS. (O'Connor, NH)

13250: Nighthawk w/MARS type pp in USB at 2114. (Hill, MI)

13330: Juliet-Oscar 55 Alpha wkg unid LDOC for pp to dispatch & wx for Chicago. USB at 1622; Boyeros LDOC wkg Oscar Oscar 1945 w/tfc. USB at 2034. (Hill, MI)

13890: OM/RR here at 1000 rptng 287. At 1004 ended w/00000. (Mason, England)

14477: NNNOC0A, USS Raleigh wkg NNN0QLP w/pp at 2115; NNN0NZ, USS Thomas Hart wkg NNN0QLP at 2118 w/pp; NNNOCYZ, USS Whidbey Island wkg NNN0MQ, USMC Quantico at 0340 w/pp. All USB. (Syrington, OH)

14487: YL/EE w/Lincolnshire Poacher tune sign-on, sending 5F msg at 0510. Unusual that same text being sent on 9251 and 7887 kHz. all three freqs were jammed by warblers. (Mason, England)

14686: Atlas wkg Ambush & told him to standby for Slingshot in USB at 2043. Atlas told Ambush to QSY

Sierra India at 2055. (Hill, MI); Clancy & unid stn talking about tech orders and spare parts for van. Few moments later Clancy cld Atlas and asked him to contact Ambush re QSY to Xray India for comms between Clancy/Ambush. USB at 1435. (Ed.)

16985.9: Cape D'Aguilar, Hong Kong w/CW mkr at 0050. DE VPS36/61/79 PSE QSO VPS35/60/80 FOR QRY. (Ed.)

18387: Pelican 1 marking targets and tracking with his "Gadget?" Targets were slow moving (3-7 knots). Must be boats? USB at 1820. (Edmunds, FL)

20825.3: Sounds like CLP1, Havana, Cuba in CW at 1454 w/chatter in SS w/unid stn. Other end not on this freq. (Ed.)

22990: OM/EE in LSB at 1530 talking about a radar installation, mentioned Maine. There was a VFT stack on USB. (Tubbs, FRG)

23219.7: OM/EE (British accent) giving coded wx at British airports. Using colors to describe wx. Foghorn signal right on top of freq. USB at 1532. (Ed.)

25224: WLO, Mobile, AL in w/CW marker at 1549. (Hill, MI)

25391: GKE8, Portishead, Eng, w/CW marker at 1642. (Hill, MI)

25750.4: One OM/SS and two YL/SS chattering back and forth with short phrases. Weak and QRM, can't determine subject of conversation. USB at 1858. (Ed.)

25855.5: WLO, Mobile, AL wkg unid stn in CW at 1907. (Ed.)

26124: Sounds like CLA, Havana, Cuba in CW w/marker tape but tape is messed up. Hrd at 1915. (Ed.)

When Trouble Strikes

Now that the “do-everything” transceiver is standard equipment in most ham shacks, many of us don’t fix our own gear. Even technically competent hams are reluctant to dive into the subminiature surface-mount world inside a modern radio. Some people think it’s the especially wise technician who stays out of the rig until all else fails.

Sooner or later, however, every amateur setup will need some attention. So if the thought of grabbing a toolbox and a digital multimeter (or should I say an oscilloscope and a spectrum analyzer?) gives you the chills, rest assured that there’s a lot of trouble shooting power in the “tool” between your ears. Nobody’s found anything better than common sense, especially when it comes to beating ol’ Murphy.

When something goes wrong, eliminate the simplest possibility right away: Is the radio plugged in? You may laugh, but as any professional technician can tell you, a lot of service calls could be avoided by covering the basics.

Beyond checking out the power cord, simply asking someone for advice is often a good way to solve a frustrating problem. Chances are good that one of your ham friends has had a similar encounter with Murphy and can probably suggest a reasonable cure. And don’t be afraid to ask for help, either: two brains are almost always better than one!

When you have a problem with your rig, don’t be in a hurry to “open the hood” and look inside. There’s probably not going to be a big arrow pointing to the problem . . . You might spot a burned resistor or a loose wire, but you’re just as likely to break a wire in the process of getting the thing opened up. Sit back and *analyze* the problem before you dig in. What are the possible causes?

Your thoughts should go from general to specific. For example, if your rig is completely dead, don’t open it up and start testing the transistors in the speech processing circuit! Here are a few things to consider:

- Did the rig fail when you were using it, or was it dead when you tried to turn it on? If it’s dead today and it wasn’t yesterday, what’s different? Could someone have tweaked a control? Was there an overnight electrical storm? Extreme cold? *Analyze!*

- If the failure occurred right in front of you, were there any obvious symptoms? Did you hear any crackling noises or see any sparks? Any strange smells? What exactly



The day after her new Novice license arrived, Susan Babcock, KB8KYD, made her on-air debut. Her first five contacts were LA6FFA on 10-meter SSB, and F5AM, YO9BEI, HA3RC and G2FRT on 15-meter CW. The 11-year-old sixth-grader from Grosse Pointe, Michigan, was 1/20 of the way to DXCC in her first hour of operation, and within a week, she added Denmark and Brazil. (NU8A photo)

were you doing when the failure occurred?

- If it’s not a complete failure, can you localize the problem. Is it confined to one band? Do you use a different antenna on that band?

- If the rig’s completely dead, make sure there’s 120 V at the wall socket. A popped breaker may be the culprit.

- Have you read the equipment manuals yet? You know, the ones nobody likes to read from cover to cover.

- Is your coax or feed line intact? There’s no chance of water contamination, is there? Are the connectors on right? (One subset of Murphy’s Law deals exclusively with connectors!)

- If you have two VFOs, are you switched to the right one? Many older rigs with out-

board VFOs require a shorting plug if the secondary VFO is not connected. Read the fine print!

- Check the front panel. Is the squelch turned down? RF gain up? Is the preselector tuned correctly? Any problems here can make even the best receiver seem dead.

- How about your keyer? Some need different settings for tube and solid-state rigs. Again, read the manual.

- Make sure you’re not plugging your headphones into the mike jack, and vice versa. Headphones make lousy microphones!

- If your rig has tube finals, is the filament power on, or did you merely turn on the high voltage? You can’t get out that way!

- Trouble with your antenna tuner? Is the correct antenna attached? Is the antenna selector switch set correctly? If you’re using an internal balun or are matching open-wire feeders, many antenna tuners require an external jumper to function properly. Does yours?

There are also a few things you can do before trouble strikes. Think of them as Murphy repellent:

- When your rig is functioning properly, take a few minutes to make a chart of the front-panel control settings. When you have problems later, you can quickly compare settings. This is especially useful if you have children who like to “play” with your radios when you’re not around. (Make sure the power to such radios is disabled—for your children’s protection and yours.)

- Don’t skimp on labels. If you bring more than one feed line in from the outside, label them. If you build your own equipment, label the controls. You may remember what everything does today, but will you remember forever? Murphy loves unlabelled boxes!

- Try to use standard connectors for RF, audio and power. Don’t use PL-259s for power connectors, and don’t use RCA jacks for RF. Sooner or later you’ll misconnect something and Murphy will be right there.

All of these ideas may seem like common sense, but most of us have had to learn them the hard way. Believe me, when it comes to Murphy, a little prevention is worth a lot of troubleshooting!

Send your letters, photos and suggestions to me at ARRL, 225 Main Street, Newington, CT 06111. Good luck—and may all of your encounters with Murphy be positive! ■

WASHINGTON PULSE

FCC ACTIONS AFFECTING COMMUNICATIONS

New Codeless Amateur Operator License

The FCC revised the examination requirement for the Technician Class operator license, thereby creating a new codeless class of amateur operator license. After these revisions become effective, an examinee will not be required to prove that he or she can send and receive texts in Morse code telegraphy signals to qualify for a Technician Class amateur operator license.

The amateur service currently consists of five classes of licenses having increasing privileges and each being progressively more difficult to obtain. The classes are Novice, Technician, General, Advanced, and Amateur Extra.

The FCC noted that offering a codeless class of license that authorizes control operator privileges at stations which transmit exclusively above 30 MHz, provides an entry level opportunity to otherwise qualified persons who find telegraphy a barrier to pursuing the purposes of the amateur service.

Therefore, the FCC has established the Technician Class as the codeless class of license. This license includes all amateur operator privileges above 30 MHz. The commission also amended the rules to grandfather frequency privileges below 30 MHz to current Technician Class licensees.

In addition, the Commission decided to retain the Novice Class operator license in order to provide an alternate entry level operator license opportunity to persons who desire to pursue the purpose of the amateur service and who can pass a telegraphy requirement in place of the more comprehensive written examination requirement for the codeless Technician Class operator license.

Amateur Service More Accessible To Handicapped Operators

The Commission amended its rules to make the amateur service more accessible to amateur operator licensees who, because of severe handicaps, are incapable of passing the higher speed Morse code telegraphy examinations. However, the FCC declined to provide a list of disabilities. Instead, the judgment of a physician will be relied on to establish that a person is severely handicapped and cannot pass a telegraphy examination.

On August 1, 1990, the FCC proposed exempting from the 13 and 20 words per minute (wpm) telegraphy examinations amateur operator licensees who are incap-

able of passing those examinations due to severe handicaps. Because of international requirements, however, no exemptions would be granted from the 5 wpm telegraphy examination.

The rules adopted require a physician's certification and a release permitting disclosure to the FCC of medical information pertaining to the handicap. The Commission said that the term "physician" would be limited to practitioners with full medical privileges, that is, doctors of osteopathy or doctors of medicine.

With respect to whether administering volunteer examiners (VEs) should administer examinations that they had not passed, the Commission said that any VE who is not competent to perform the VE functions should not administer examinations.

Defendant Sentenced In Satellite Jamming

United States District Court Judge Rebecca Beach Smith, Eastern District of Virginia, Norfolk, Virginia, sentenced Thomas M. Haynie of Virginia Beach, Virginia, to three years imprisonment, all of which was suspended; to pay a \$3,000 fine, \$2,000 of which was suspended; and to perform 50 hours of community service work each year for the next three years. Haynie had been convicted on September 24, 1990, by a federal jury in Norfolk of causing intentional interference to a communications satellite and unauthorized operation of a satellite uplink transmitter. The sentence was imposed for a felony violation of Title 18, United States Code, Section 1367.

Haynie, an employee of the Christian Broadcasting Network, Inc. (CBN), Virginia Beach, was convicted of one count of using that organization's satellite transmission equipment to cause intentional and unauthorized interference to "The Playboy Channel". That cable television service operates on the GE SATCOM IV communications satellite. On September 6, 1987, Haynie used the satellite uplink station to send a biblical message to Playboy viewers which read, "THUS SAYETH THE LORD THY GOD. REMEMBER THE SABATH AND KEEP IT HOLY. REPENT FOR THE KINGDOM OF HEAVEN IS AT HAND" (sic).

Haynie was also convicted of one misdemeanor count of unauthorized operation of satellite transmission equipment. Judge Smith deferred sentencing on that count for three years.

Richard M. Smith, Chief of the FCC's Field Operations Bureau, commented that

this case will serve as a deterrent to other potential violators. He also noted that it was the most complex jamming investigation ever undertaken by the FCC. Haynie's conviction and sentencing culminates an intensive three-year long investigation by the FCC's Field Operations Bureau and the Norfolk Office of the FBI.

Suspension Orders To Two Radio Operators For Unlicensed Facilities

The FCC, in separate actions, suspended the licenses of radio operators Frederick K. Stark, holder of a General Radiotelephone Operator License, and Joseph A. Della Barba, holder of a Restricted Radiotelephone Operator Permit. Investigations showed they were operating unlicensed broadcast facilities. Each operator had been previously fined \$1,000. The suspension orders will be held in abeyance pending a hearing, if the radio operators request one, or until the time for requesting a hearing has expired.

The Stark investigation was initiated after complaints from the New York State Broadcasters Association alleged interference to a licensed facility. Stark, using the call sign "WNYS" operated an unlicensed station on 1000 KHz in the AM frequency band. Della Barba's broadcasts, using the call sign "WTNU", were made on the shortwave frequencies of 25,000 KHz allocated for standard frequency and time signals and 15,043 KHz, assigned for aviation use.

Unlicensed radio operation is a violation of Section 301 of the Communications Act of 1934, as amended. Other sanctions may include administrative fines of up to \$10,000 and/or criminal penalties of up to \$100,000 and/or imprisonment for up to one year.

Illegal CB Equipment Seized In Duluth, Georgia

The U.S. Marshal's Service, and the Federal Communications Commission's Atlanta Office executed a criminal search and seizure warrant at the residence of Ben Pitts, Duluth, Georgia. Four linear amplifiers and eleven transmitters were seized from his home and automobiles.

The seizure was the result of a lengthy investigation conducted by the FCC's Atlanta Office as part of a continuing nationwide enforcement program to reduce instances of CB interference to home electronic entertainment equipment. Linear amplifiers can disrupt authorized communications and cause interference to home electronic entertainment equipment. Mr. Pitts' radio opera-

tions allegedly caused extensive interference throughout his neighborhood.

The search warrant was obtained by Assistant U.S. Attorney William Toliver, Northern District of Georgia, on behalf of the Federal Communications Commission. The use of such illegal equipment is prohibited by the Communications Act of 1934, as amended and FCC rules and regulations. Criminal penalties can include fines of up to \$100,000 and/or imprisonment for up to 1 year.

FCC Relaxes Radio Frequency Field Strength Limits For Low Power AM Communications Systems

The Commission granted, in part, requests by various entities to amend its rules regarding the operation of radio frequency devices without an individual license. Specifically, the Commission has relaxed the radio frequency (RF) field strength emission limits for low power AM communications systems, such as carrier current and "leaky cable" radio systems on the AM band.

LPB Inc., LocRad Inc., Burden Associates, and the Intercollegiate Broadcasting System, Inc., sought partial reconsideration of the Commission's March 30, 1989, First Report and Order which revised Part 15 of the rules governing the operation of radio frequency devices without an individual license. The petitioners market and operate low power carrier current and "leaky cable" systems that transmit one-way messages and programming for reception on standard AM broadcast band receivers. Such systems include motorist advisory stations, aids for the hearing-impaired, campus radio stations and systems used for drive-in theaters and churches.

In its request, the petitioners expressed concern that the new emission limits for AM carrier current systems were more stringent for lower frequencies in the AM band than the former limits. They contended that the newly adopted lower limits were unnecessarily restrictive and asked the Commission to reinstate the previous emission limits for these systems.

Recognizing that carrier current and leaky cable systems provide valuable services which are not easily provided through other means, the Commission agreed that the former emission limits provided adequate protection to other authorized communications users. While this change will lessen the uniformity of the Part 15 emissions standards, the Commission believes that the benefits of applying the former standards in this case outweigh the advantages of uniformity.

The Commission has previously treated leaky cable systems in a manner similar to radio transmitters because, like radio transmitters, leaky cable systems are able to control the placement of their antennas. How-

ever, because leaky cable systems operate more like carrier current systems, the Commission has granted the petitioners request subject to leaky cable systems operating in the AM broadcast band, to the same field strength limits and equipment authorization requirements as carrier current systems.

Additionally, the Commission stated that by relaxing its rules, campus radio stations will now be able to use both carrier current and leaky cable systems at the signal levels specified for carrier current systems under the previous rules to serve off-campus locations such as privately-owned residence halls.

Revision Of Part 15 Upheld

The Commission denied a petition by the American Radio Relay League, Inc. (ARRL) requesting that the Commission reconsider and reverse certain portions of the First Report and Order in this proceeding which re-

vised Part 15 of the regulations governing the non-licensed operation of radio frequency (RF) devices.

The ARRL was concerned that such devices have the potential to both cause interference to, and receive interference from, stations operating in the Amateur Radio Service.

The new rules allow manufacturers to produce non-licensed equipment for use on almost any frequency, subject to emissions limits and other restrictions intended to minimize their potential for causing interference to the authorized services.

The Commission found no merit in ARRL's requests that the Part 15 emissions limits for frequencies used by amateurs be reduced, that the Amateur Radio Service bands be designated as restricted bands, and that manufacturers be required to provide interference resolution information to consumers. ■



PICKS UP A WHISPER 50 FEET AWAY!

The model WAT-50 miniature FM transmitter uses a 4-stage circuit NOT to be confused with a simple wireless microphone. Simply snap the unit on top of a 9V battery and you can hear every sound in an entire house up to 1 mile away! Use with any FM radio. Tunes to any frequency from 70mhz - 130mhz. Easy to assemble kit includes all parts and instructions. Only 29.98 tax incl.



The **WIRELESS TELEPHONE TRANSMITTER** model WTT-20 is only about the size of a dime, yet transmits both sides of a telephone conversation to any FM radio with crystal clarity. Completely automatic. Uses power from the telephone line itself - never needs a battery! Up to 1/4 mile range. Tunes from 70mhz - 130mhz. Easy to assemble kit includes all parts and instructions. Only \$29.98 tax incl.

Call or send MO, VISA, MC for immediate delivery. Single kit orders include \$1.50 S&H. FREE SHIPPING on orders of 2 or more. All orders shipped by U.S. Mail. COD add \$4.00. Personal checks allow 21 days.

DECO INDUSTRIES
BOX 607, BEDFORD HILLS, NY 10507
914-232-3878

CIRCLE 15 ON READER SERVICE CARD

Secret Frequencies

The Remote Computer Scanning System™

Turn those hours of manually searching for secret frequencies over to RCSS™. The RCSS™ significantly enhances the ICOM® R7000 receiver capabilities by providing automated PC control over receiver scanning & memory functions.



Demo Version Available

Features

- ❑ Automatic detection and storage of active frequencies & other info while scanning.
- ❑ User specified Tuning Steps from 10-100 MHz.
- ❑ Scan Mode, Class of Service, or Type of Unit.
- ❑ Scanning resumes upon loss of carrier.
- ❑ Memory capacity: 1,000 frequencies.
- ❑ Monitor half-duplex communications.
- ❑ Mouse/Keyboard driven graphic user interface.

SYSTEMS & SOFTWARE
INTERNATIONAL LTD.

4639 Timber Ridge Drive, Dumfries, VA, 22026-1059 USA
 (703) 680-3559, Fax: (703) 878-1460. RCSS™ is available for both IBM compatible & Macintosh computers.

CIRCLE 16 ON READER SERVICE CARD

ICOM™ R7000 Sweeping 1300 Channels/Min.

DELTA COMM™ 1.04 gives you a custom interface and optimized software that will not just control but will maximize the potential of your R7000. Spectrum log at speeds in excess of 1300 channels/min. while automatically generating a histogram of frequency/activity. Advanced priority channel monitoring and program control, by channel, of remote tape recorders during scanning. Here are a few (there are many more) examples of the advanced features DELTA COMM has to offer:

- Birdie log during frequency search automatically characterizes your R7000, then locks out those frequencies
- Auto histogram and scan file creation during spectrum log
- Scan file channel lock-out feature allows scanning around channels without removing that frequency from database
- Resume scan and maximum monitor values unique on each channel scanned
- Each frequency within a scan file has an area (40 characters wide) for channel information.
- Auto frequency detection and storage during search and spectrum log
- User friendly installation program reduces need for DOS knowledge
- Full support of serial ports COM1-COM4
- On-screen HELP reduces need to refer to user manual
- REQUIREMENTS: MS-DOS microcomputer with minimum 512k memory. DELTA COMM's performance is proportional to baud rate setting, style of display card and type of computer used.



\$299 Incl. Ext. Interface & Components for Cabling
 Check, MO, VISA or MASTER
 Accepted + \$4 for S&H
 (WI Res. Add 5% Sales Tax)



DELTA RESEARCH
 PO Box 13677 • Wauwatosa, WI 53213
 FAX or Phone Weekdays (414) 353-4567

CIRCLE 17 ON READER SERVICE CARD

WHAT'S HAPPENING: INTERNATIONAL SHORTWAVE BROADCASTING BANDS

Today's big question is "Is anyone hearing Radio Canada International?" If the answer is "yes" then it would seem RCI has survived yet another threat. Just as this column was being put together we learned that the Canadian government was in the process of implementing a \$350 million cutback in its existing programs in order to cover its Persian Gulf costs. One department taking a hit was the Canadian Broadcasting Corporation and CBC, under which RCI operates, had RCI on the top of the list of things to cut.

According to RCI's Ian McFarland, this time the cutbacks at RCI might be total—to the point of closing RCI. The decision to keep or close Radio Canada International has very likely already been made and any action already taken. If the worst did happen you might still hope to do some good by sending your comments to the following officials: Prime Minister Brian Mulroney; the Rt. Hon Joe Clark, Minister for External Affairs and the Hon. Marcel Masse, Minister of Communications. The address for all three is: the House of Commons, Ottawa, Canada. Thanks to Tom Sundstrum and his column in *The Journal of the North American Shortwave Association* for the information.

Here is some "fer shur" bad news: KUSW in Salt Lake City aired its last broadcasts in mid-December before relinquishing control to the station's new owners—Trinity Broadcasting, which bought the station for \$2 million. Trinity—which operates the TBN satellite network as well as several low power TV stations, was scheduled to air religious programming 24 hours per day and use a new set of call letters—KTBN. KUSW was last scheduled for 9815 from 0300-0500, 9870 0500-1400 and 15590 from 1400-0300, so check these frequencies for the Trinity broadcasts.

Radio Miami International, the hoped-for new shortwave station which would focus its programming in the Caribbean area, has amended its FCC application, increasing its proposed power from 10 to 50 kW. 50 kW is the minimum for a US shortwave broadcaster. Radio Miami tried to argue the merits of using only 10 kW, saying that this would be quite adequate for the coverage area. But once the group learned how small the chances of getting a waiver were they amended their application and are now hoping for a smooth ride through the bureaucracy to approval. We'll keep you posted.

Spanish National Radio has been moving toward putting a high power relay on the air from Costa Rica for a couple of years now and the word is that this is now fairly close to reality and may even be on the air by the time you read this. Such a relay still seems unnecessary for North American listeners,

Last QSL

Radio
Berlin
International
The Voice of the
German
Democratic
Republic

Nalepastraße 10-50
Berlin
DDR - 1160



0623 19 90

This is to verify receipt of 1 correct
reception reports dated 06.3.1990

This verification is equivalent to the above
Indicated QSLs and may therefore
be submitted in application for awards.
We hope you will continue to receive
and enjoy our programmes.

William Moser and Edouard Provencher got "Last QSL" cards from Radio Berlin International.

considering how well this station is heard direct.

Also from Costa Rica, look for stronger signals from Radio For Peace International. They're in the market to replace their low power home made transmitters with units running around 50 kW. Still another Costa Rican station, Radio Lira, has upped its power from 5 to 60 kW and is well heard now, particularly on 9725 and 11870.

The Dutch government has put the kibosh on Radio Netherlands' plans for a relay base in Thailand. The relay would have improved the station's coverage in the Far East but the government said the goal wasn't worth the cost.

By now all of the local broadcasters in Papua New Guinea will have upped power from 2 to 10 kW. The last to make the upgrade included Radio Eastern Highlands on 3395, Radio Southern Highlands on 3275, Radio Manus, 3315, Radio Northern,

3345, Radio West New Britain, 3235 and Radio New Ireland, 3905. The best time to log the Papua New Guinea stations is around your local sunrise during the spring and fall seasons.

THE MAIL MAN ARRIVES: William Moser and Edouard S. Provencher are two of several lucky folks who took a chance and sent a report to Radio Berlin International on their last day of operations even though the word was that they'd be closing down as soon as unification happened. Bill and Edouard both received RBI QSL's stamped "Last QSL." Congrats, guys. Surely an unusual piece of history there: next best thing to a hunk of the Wall!

Kevin Story in Texas is celebrating, a quick QSL from the often tough SLBC in Sri Lanka. They replied to Kevin in only 54 days. CRTV-Yaounde, Cameroon and CKZN, St. John's, Newfoundland are other recent prizes in the Storied collection. Nice going,

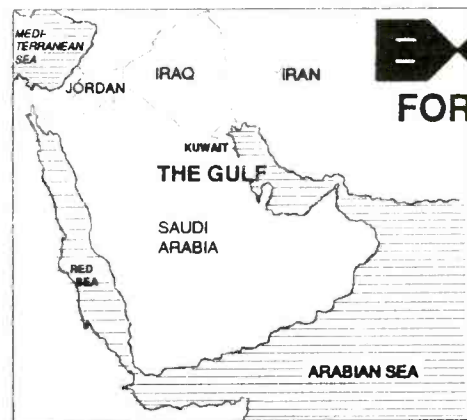

BFBS
FORCES RADIO

BFBS LONDON
Bridge House
North Wharf Road
London W2 1LA
Tel: 071 724 1234
Fax: 071 706 1582

The Radio Division
of
SISVC

*Special broadcasts from BFBS to the British military in the Gulf are QSL'd with this card.
Thanks Mark Johnson, Minneapolis.*

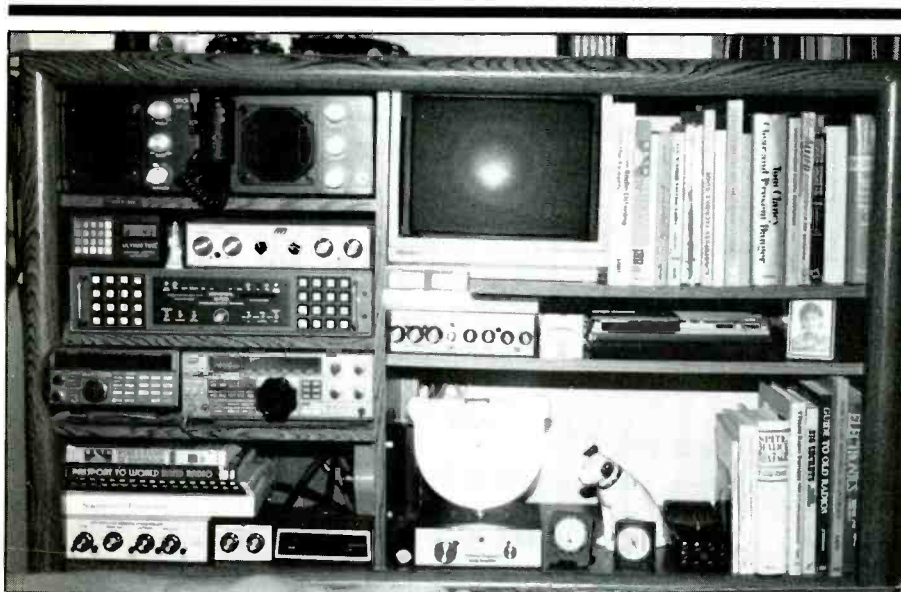

The shack of John Green, Loveland, Ohio is equipped to monitor just about everything—from broadcast to FAX. Equipment includes a Kenwood R-5000, Yaesu 9600 and Universal/InfoTech M-7000 RTTY/CW/Fax decoder.

Kevin. If you keep working at it you'll keep on scoring!

Aris Giannarelis of Greece forwards a copy of a special QSL certificate given out by Radio Norway for the first 100 reports on its Saturday English broadcasts. Very nice!

Ed Provencher of Biddeford, Maine has a very large QSL collection he's built over some two decades of effort. Now he's looking more and more for "special" QSL possibilities—cards commemorating special station or national events, tests, first and last day broadcasts and so on. He has a German QSL dated the day the Wall came down and another for Deutschmark Day. Incidentally, Ed says he's had several requests for copies of his own "frog" SWL card which appeared in this column some months ago.

Randy Bradford of Bellevue, Nebraska is returning to the SWL ranks after a long lay-off and is using a Kenwood R-2000 on an in-

door antenna. We're looking for those promised logs, Randy!

William Moser of New Cumberland, Pennsylvania has compiled a set of "Murphy's Laws" for SWL's:

A sudden fading or crack of static will always follow the words "This is Radio . . ." when you've listened for half an hour for the ID of a rare station.

If, after listening to static and low level signals for half an hour, you finally hear the ID, it will be the Voice of America.

The foreign language you have struggled through an entire program to identify is—English.

When broadcasts from some part of the world become very interesting the schedule will mysteriously change or someone will pull the plug on the station.

Mother Nature always sides with poor propagation.

Your incredible new antenna of which you are very proud will actually make reception worse.

After you finally QSL a notorious non-verifier you find that they have changed their policy and now verify any report they can read.

The one week of a shortwave foreign language course you miss will be the one the rest of the course depends on.

Very good, Bill, and very true. Thanks!

Here's our usual invitation to you to send in your logs each month or whenever you can. Please list your loggings by country, leave some cutting space between each item, and add your last name and state abbreviation after each. We're also interested in shack photos and spare QSL cards to use as illustrations. Station schedules, literature, news clippings and your comments and questions are also very welcome. Thanks for your continued support.

Here are the logs. All times are UTC and broadcast language English (EE), unless specified as SS for Spanish, FF for French, AA for Arabic, etc.

Albania: Radio Tirana, 9480 at 0438, 9500 at 1420, in slavic language, 11895 in SS at 2030. (Carson, OK) 11825 at 0230. (Moser, PA)

Algeria: Radio Algiers, 1958 with ID, frequency and address on 9535. Into SS at 2000. (Johnson, IL)

Angola: Radio Nacional, 9535 at 2210 with American pops, PP ID and vibraphone IS at 2230. (Johnson, IL)

Antigua: Deutsche Welle relay, 9545 at 0302 with news. (Moser, PA) BBC relay, 5875 at 0234. (Moser, PA)

Argentina: Radio Continental, USB feeder of Buenos Aires 590 kHz MW at 0010 in SS on 9115 with football. Relayed by General Pacheco Radio. (Johnson, IL)

Radio Nacional, 6060 at 0850 in SS with talk and ID. (Johnson, IL) RAE at 0100 on 11710. (Pellicari, CT)

Armenia: Radio Yerevan, 15180 and 17690 in EE at 0353. (Bailey, AR) (relayed by Radio Moscow transmitters. English runs only about 5 minutes, beginning about 0350. Editor)

Australia: ABC/Camma Radio at Alice Springs on 2310 at 1150 in aboriginal language with pop. Parallel 2325, VL8T at Tennant Creek. (Johnson, IL)

Radio Australia, 9580 at 1216. (Moser, PA) 15160 at 1313. (Carson, OK) 17795 at 0250. (Bailey, AR)

ABC, Brisbane, 9660 at 0936 with humor and pops. (Carson, OK)

Austria: Radio Austria International, 6015 (via Canada, editor) at 0532. (Moser, PA) 9875 at 0130. (Pellicari, CT) 11780 at 1430. (Johnson, IL) 21490 at 1440. (Carson, OK)

Bangladesh: Radio Bangladesh, 4879.9 at 1245 with exotic sitar music, news and YL with ID "This is Radio Bangladesh." 15195 at 1230f YL with sign on, news. (Johnson, IL)

Belgium: BRT on 9925 at 0043. (Carson, OK) 15515 at 1838 with "Brussels Calling." (Johnson, IL)

Benin: ORTB on 4870 at 0507 with pops, EE vocals, announcer in FF. (Johnson, IL)

Bolivia: tentative Radio Indoamerica, 6175, 1120 soft music and SS talk, sounded like a sermon. ID sounded like "Radio Indoamerica" but lots of QRM. (Johnson, IL (or TIFC, Costa Rica? editor)

Botswana: Radio Botswana, 7255 at 0415 with economic talk. (Johnson, IL)

Brazil: Radio Anhanguera, 4915 in PP at 0715 with ballads, ID "An-han-guera!" (Johnson, IL)

Radio Brazil Central, 4985 at 0640, man in PP with "sleepy" Brazilian pops. (Johnson, IL)

Radio Guaiba, 6000 at 0827. ID in PP, instrumental music. (Johnson, IL)

Radio Inconfidencia, 6010 at 2246. "Radio Inconfi-



Ed Provencher got this QSL for Radio Moscow's broadcasts in Portuguese to Brazil.

Abbreviation Used In Listening Post

AA	Arabic
BC	Broadcasting
CC	Chinese
EE	English
FF	French
GG	German
ID	Identification
IS	Interval Signal
JJ	Japanese
mx	Music
NA	North America
nx	News
OM	Male
pgm	Program
PP	Portuguese
RR	Russian
rx	Religious
SA	South America/n
SS	Spanish
UTC	Coordinated Universal Time (ex-GMT)
v	Frequency varies
w/	With
WX	Weather
YL	Female
//	Parallel frequencies

dencia" ID and PP commercials. Also Brazilian polkas. (Johnson, IL)

Radio Cultura do Para, 5045 at 0905. ID, many mentions of Para and Belem in PP. (Johnson, IL)

Bulgaria: Radio Sofia, 11750 at 0420. (Bailey, AR)

Burkina Faso: Radio Burkina, 4815 at 0558 with national anthem sign on in FF. (Johnson, IL) 063, lively music, clear FF ID. (Moser, PA)

Canada: Radio Canada International, 5960 at 0125. Into FF at 0130. 9755 at 2320. 2221 on 11705 and into FF at 2230. (Carson, OK) 6175 at 0235 and 11855 at 1340. (Moser, PA) 7390 at 0256 with IS. (Johnson, IL) 13650 at 1719 and 13720 atn 0207. (Bailey, AR) 15260 at 1800. (Pellicciari, CT) 21545 at 1518. (Zamora, ND) CFRX, 6070, 0833, 1524, 2217. (Carson, OK)

Cameroon: CRTV Bafoussam, 4000 at 0512 with talk in FF, upbeat music. (Johnson, IL)

CRTV Garoua, 5010 at 0515, upbeat music, man with commentary in EE between songs, flute IS at 0530 and into FF. (Johnson, IL)

Central African Republic: RTV Centrafricaine, 5035 at 2215 with man in FF and program of great jazz music. (Johnson, IL)

Chad: Radio Nationale, 4904.5 at 0430 with national anthem sung by children, FF announcement, music. (Johnson, IL)

China: Radio Beijing, 11835, 0523, with current affairs program. (Carson, OK)

Yunnan PBS, 4760 at 1210 with YL and OM in CC. (Johnson, IL)

CPBS-1, 5320 at 1205 with long talk in CC. (Johnson, IL)

CPBS minorities service, 5420 at 1240, talk in unidentified CC dialect. (Johnson, IL)

Colombia: La Voz del Llano, 6115 at 2337, man in SS with ID at 2338. (Moser, PA)

La Voz del Cinaruco, 4865 at 0220 with ID and frequency announcement, Latin rhythms. (Johnson, IL)

Congo: RTV Congolaise, 4765 at 2210 in FF with lots of hi-life music. And 15190 at 1505 with hi-life and talks in vernacular. (Johnson, IL)

Costa Rica: Radio Reloj, 6005 at 0915 in SS with ID, Latin music. (Johnson, IL) (43-832 is apparently off the air. Editor)

AWR on 9725 at 1212 and 2302. (Moser, PA)
Radio For Peace International, 7375USB at 0215 and 0850. (Carson, OK) 13630 at 2300. (Bailey, AR)

Cuba: Radio Havana, 9750 at 0435. (Carson, OK) 11820 at 0003. (Moser, PA) 0252. (Bailey, AR)

Radio Rebelde, 5025 at 0326 with "Radio Rama" program - American rock with DJ in SS. (Johnson, IL)

Cyprus: BBC East Mediterranean relay on 7135 at 0233 with sports. (Moser, PA)

Czechoslovakia: Radio Prague International on 5930 at 0400. (Pellicciari, CT) 5930//7345 at 0300 sign on. (Moser, PA; Carson, OK)

Denmark: Radio Denmark, (via Norway) on 15165 with local news in Danish, EE ID at 2030. (Vaage, CA)

Ecuador: HCJB, 15155 at 0245. (Bailey, AR) 17790 at 1920. (Moser, PA)

SPECIAL VERIFICATION

NO
51

Radio Norway International is pleased to confirm that our listener

Arislides Giannarelis

has reported listening in to Radio Norway International's first ever regular Saturday transmission in English on September 8, 1990. The report, concerning our transmission at . . . 16 . . . UTC, on 25: 7.30 . . . MHz, has been found in full correspondence with our station log.

This special verification is issued in 100 copies only.



Sverre Fredheim
Head of External Broadcasting
Radio Norway International

Radio Norway's QSL certificate issued to the first 100 reporters on the beginning of Saturday broadcasts in English. (Aris Giannarelis, Greece)

25950 at 1330; 1900. (Zamora, ND; Watts, KY)

Radio Quito, 4919.9 at 0525 with American rock, man in SS. No ID heard. (Johnson, IL) (Guess it's that syndicated US program they're running, Tim. Editor)

Egypt: Radio Cairo, 9400//12050 at 0430 in AA with Koran recitations, commentaries, bell tolls at 0500, then news. (Johnson, IL) 9475 at 0226. (Moser, PA) 9900 at 2115 sign on. (Watts, KY)

England: British Forces Broadcasting Service, via BBC, 13745 at 0158 with messages to troops from families, rock. Address given as BFBS (SSVC), Attn: Station Manager, Bridge House, North Wharf Rd., London, W2, England. (Bailey, AR) 0215-0230 close. (Johnson, IL) 17695 at 1339. (Carson, OK) And //21735 at 1330 to 1359 close. (Zamora, ND)

BBC, 7325 at 0421. (Bailey, AR) 11940 at 0430 sign on. And 15220 at 1309. (Carson, OK) 15280, via Hong Kong relay, 0553. (Foss, AK)

Equatorial Guinea: Radio Nacional, 5003.5 at 2157 with sign off routine in SS, long anthem. (Johnson, IL)

Radio Africa, 7188.5 at 2150 with religious programming. (Johnson, IL)

Ethiopia: Voice of Ethiopia, 9560 at 1430 with African music, AA and into EE at 1500 with chimes, ID and news. (Story, TX)

Finland: Radio Finland International, 11755 at 0739, into FF at 0745. 21555 at 1300, 1400, 1500. (Carson, OK) 15400//21555 at 1209. (Moser, PA)

France: Radio France International, 15365 in FF with rock at 0433. (Foss, AK) 21770 at 1410. (Moser, PA) 25820 at 1315 in FF. (Zamora, ND)

Gabon: Africa No. One, 9580 at 0644 with music, YL in FF. (Moser, PA) 15475 in FF at 1845 with news, YL with ID, then news in EE. (Johnson, IL)

Germany: Deutsche Welle, 6120 at 0301. (Bailey, AR) 6145 at 0112. (Moser, PA) 9545 (via Antigua) at 0339. 13770 at 0300 and //6085. (Carson, OK) 25740 in GG at 1307. (Zamora, ND)

Bayerischer Rundfunk, 6085 at 0710 with marches, yodels, polkas. GG announcer. (Johnson, IL)

RIAS, Berlin, 6005 in GG at 0525; 0615. (Moser, PA; Watts, KY)

Ghana: GBC-1, 4915 at 2245 with news. (Johnson, IL)

Greece: Thessaloniki, 11595 in GG to 2300 sign off. (Watts, KY) VOA relay, 15160 at 1400. (Watts, KY)

Guam: KTWR, 11650 at 0530 with inspirational program. (Moser, PA) 15200 at 0801 "This is the Voice of Trans World Radio Pacific, KTWR, Agana." (Johnson, IL)

Guatemala: Radio Cultural, 3300, 0218 with clas-

sical music, SS, marimbas. Into EE at 0300. (Carson, IL) SS at 0224. (Moser, PA)

Radio Buenas Nuevas, 4799.8 at 0445 man with ID and child vocals. (Johnson, IL) (SS? Editor)

Hawaii: WVVH at 1207 on 5000, woman with time announcements. (Moser, PA)

Honduras: HRVC on 4820 at 0233 with SS and EE religious program. (Moser, PA)

Hungary: Radio Budapest, 9520 at 0130, 9835 at 0205 and 11910 at 0237. (Carson, OK)

Iceland: Icelandic National Broadcasting System, 13855 at 1908 and 2328 in presumed Icelandic. (Johnson, IL)

India: All India Radio, 9730//11620 at 2045 with commentary. (Johnson, IL) 11620 at 1858; 2045. (Moser, PA; Watts, KY)

AIK - Delhi, 4860 at 1255 with sitar music, YL with ID "This is All India Radio." (Johnson, IL)

Indonesia: RRI Ujung Padang, 4719.3 at 1310 in II with Indo pops. 4753.2 at 1130 in II. (Johnson, IL)

Iran: VOIRI at 1942 on 9022 with news and political commentary, exotic Persian music. (Johnson, IL)

Iraq: Radio Baghdad, 11860 at 2006 with man and woman in AA under heavy jamming. 13660 at 2115 with exotic music and some features. A couple of western pops played "I'm Gonna Make You Wish You Loved" and from Dick Tracy soundtrack "Who Could Ask For Anything More." Program "Iraq Today" at 2115. (Johnson, IL) Messages from the American hostages aired at 2144. (Bailey, AR)

Israel: Kol Israel, 9435 at 0205. (Carson, OK) 11605 at 0000; 0110; 0511. (Moser, PA; Foss, AK; Bailey, AR)

Italy: RAI, 9575 with news at 0100; 0111. (Pellicciari, CT; Moser, PA)

Japan: Radio Japan, 5960//6210 (you mean 6120?) at 0310. (via Canada, editor) (Johnson, IL) 11835 (via Gabon, editor) at 2336. (Carson, OK) 15325 (via French Guiana, editor) at 0315. (Foss, AK) 21700 (via Gabon) at 1534. (Moser, PA)

Nihon SW Broadcasting (Radio Tanpa), tentative, 9595 at 1445 with JJ/EE language learning program, music near the hour, then ID. (Johnson, IL)

Jordan: Radio Jordan, 9560 at 1719, man announcer, news. 11955 at 0645, exotic music, man in AA with phone-in show. (Johnson, IL)

Latvia: Radio Riga, 5935 with IS at 0357. (Watts, KY)

Lithuania: Radio Vilnius, 7400 at 2300. (Pellicciari, CT) 11790 at 2302. (Carson, OK) 17690 at 2303. (Moser, PA)

Luxembourg: Radio Luxembourg, 6090 at 2205 in GG. (Moser, PA)

Malaysia: Radio Malaysia - Sarawak, 4950 at 1140 with news, ID, commentary. 7160 at 1100. (Story, TX)

Malta: Voice of the Mediterranean, 9765 at 0600 sign on. Guitarr music. Heavy QRM. (Johnson, IL) 0628. (Moser, PA)

Deutsche Welle relay, 11865 at 0114. (Moser, PA)

Mauritania: ORTM, 4845, Mauritanian guitar and Koran recitations. (Johnson, IL) Recitations in AA at 0630. (Story, TX) 0658 in FF or AA. (Moser, PA) 0710. (Pellicciari, CT)

Monaco: Trans World Radio, 9480 with "Hour of Freedom" at 0815. (Watts, KY)

Morocco: VOA Tangier relay, 6095 at 0610. (Johnson, IL)

Mozambique: Radio Maputo on 7242 at 0757 sign off with "Radio Maputo" EE ID and 4 gongs IS. (Pellicciari, CT)

Mynamar (Burma): Voice of Mynamar, 4725 at 1307 with talk in unidentified southeast Asian language. Weak. (Johnson, IL)

New Zealand: Radio New Zealand International, 9695 at 0902 and 9855 at 0715 with old records and cricket scores. (Watts, KY) 17675 at 0343. (Bailey, AR)

Niger: ORTN, 5020 at 0520 in FF with flutes and drums. (Story, TX) 0550. (Johnson, IL)

Nigeria: Radio Nigeria, Lagos, 4990 at 0500 with station promo, and pops. (Johnson, IL)

Radio Nigeria, Kaduna, 4770 at 0512 with records and talk on agriculture. (Johnson, IL)

Netherlands: Radio Netherlands, 6020 at 0030. 15560 at 0047 and 0746. (Carson, OK)

Netherlands Antilles: Radio Netherlands relay, 9590 at 0350. (Moser, PA)

Trans World Radio, Bonaire, 9535 at 0400. (Bailey, AR) 11930 at 0300 and 15345 at 1303. (Carson, OK) 11815 at 1055 with IS, ID and sign on. (Moser, PA)

North Korea: Radio Pyongyang, 6576//9977 at 1120 "how political work should be done." (Johnson, IL) 9977 at 1101. (Moser, PA) 15115 at 0000 with news, commentary, revolutionary songs. (Pellicciari, CT)

Northern Marianas: KHBI, Christian Science Network, 9530 at 1056 with frequencies, headlines. (Moser, PA) 13625 at 1425, news at 1430. (Carson, OK)

Norway: Radio Norway International, 9615 at 0200 with a program called "The Miserable Life and History of Norway."—what a title! (Pellicciari, CT) 15145 with Norway's IS and then 0430 with Radio Denmark. (Johnson, IL) 15165 with news in NN, EE ID at 2029. (Vaage, CA) 17755 at 1815 in EE. (Bailey, AR) 21705 in NN at 1558 with IS. (Moser, PA) (Norway has EE only on Saturdays and Sundays. Editor)

Oman: BBC Relay, 11760 at 0063. (Johnson, IL)

Pakistan: Radio Pakistan, 13665 at 1602 with regional news. (Johnson, IL)

Paraguay: Radio Nacional, 2335 with music, ID in SS. (Moser, PA) 0015 with football match in SS. Coca Cola advertisements. (Johnson, IL)

Peru: Radiodufosora Huanta, 4889.7 at 1105, tentative, Latin ballads and man in SS. (Johnson, IL)

Radio Cora, 4914.6 at 1040 with instrumental Latin music, time announcements before each song by YL in SS, occasional ID. (Johnson, IL)

Philippines: VOA relay, 9760 at 1500 sign off. (Watts, KY) VOA Poro relay on 15290 at 0009. (Moser, PA)

Poland: Radio Polonia, 7270//9675 at 0632 with news. (Moser, PA) 9540 at 1559 with IS and several IDs. (Johnson, IL)

Portugal: Radio Portugal, 9705 at 0258 with frequencies, ID. Better than //9680. (Moser, PA) 11840 at 0247 in PP. (Carson, OK) 15140//21495 "futbol" play-by-play. (Johnson, IL)

Romania: Radio Romania International, 9510 (covered by WYFR) //11940 at 0400, news and comment. (Carson, OK) 9690 at 1940 and 11940 at 1210, the lat-

1991 PASSPORT TO WORLDBAND RADIO

Your Complete Guide To Shortwave Listening

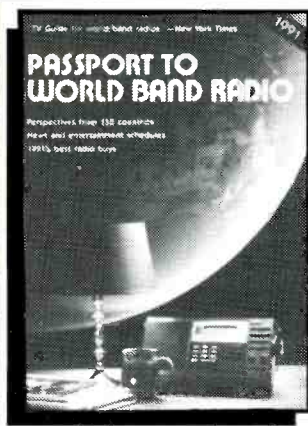

Here is your *must have* companion to shortwave listening! The all-new 1991 **Passport** covers worldwide broadcasting by frequency, by country and hour-by-hour. It's jam packed with just the information you need for every transmitter on the air - from Afganistan to Zimbabwe. There is also Passport's award-winning Buyer's Guide, with hard-hitting ratings of virtually every receiver on the market. Plus the latest on news, music, places to write and how-to tips. No wonder this is North America's best selling guide to shortwave listening!

Only \$16.95 (+\$1)

Other Titles Available...

- ◆ World Radio TV Handbook 1991 \$19.95 (+\$1)
- ◆ Shortwave Receivers Past & Present \$ 6.95 (+\$1)
- ◆ The DXer's Directory 1990-91 Edition \$ 4.95 (+\$1)
- ◆ FM Atlas & Station Directory \$10.95 (+\$1)
- ◆ Pirate Radio Stations \$11.95 (+\$1)

Universal Radio
1280 Aida Dr. Dept. PC
Reynoldsburg, OH 43068
■ Toll Free: 800 431-3939
■ In Ohio: 614 866-4267

★ **HUGE CATALOG** ★
Universal publishes a giant 92 page communications catalog covering shortwave, amateur and scanner products with prices. Only \$1 postpaid.

Computer Aided Scanning

a new dimension in communications from Datametrix



Now you can enhance your ICOM communications receiver through a powerful computer controlled system by Datametrix, the leader in Computer Aided Scanning. The system is as significant as the digital scanner was five years ago and is changing the way people think about radio communications.

The Datametrix Communications Manager provides computer control over the ICOM R7000 or R71A receiver.

Comprehensive manual includes step by step instructions, screen displays, and reference information.

Powerful menu driven software includes full monitoring display, digital spectrum analyzer and system editor.

Innovative hardware design requires no internal connections.

Extends ICOM capabilities including autolog recording facilities, 1000 channel capacity per file, and much more.

Overcomes ICOM limitations such as ineffective scan delay.

Datametrix, Inc

R7000 system \$349
R71A system \$349
Manual and demo disk \$15

Requires ICOM receiver and IBM PC with \$12K and serial port. The R71A version also requires an ICOM UX-14.

Send check or money order to Datametrix, Inc, 2575 South Bayshore Dr, Suite 8A, Coconut Grove, FL 33133. 30 return privileges apply.

CIRCLE 99 ON READER SERVICE CARD

ter in GG. (Johnson, IL) 21655 at 1300 sign on, news. (Zamora, ND)

Saudi Arabia: BSKSA, tentative on 15060 at 0357 with guitar IS and into Turkish. Also tentative on 9885 at 2135 with exotic music, AA by two announcers over bubble jammer. Mentions of "Arabiyah." (Johnson, IL)

Singapore: BBC relay, 7325 at 1200, world news. (Johnson, IL)

South Africa: Radio Suid Afrika, 3320/4810 at 0400, Afrikaans and lots of elevator music. 4910 at 0300 sign on in Afrikaans. (Johnson, IL)

Radio RSA, 9570 with IS at 2050. (Johnson, IL) 17745 at 0355 in FF with EE ID. (Carson, OK)

South Korea: Radio Korea, 9640 at 1140 with

"Shortwave Feedback" program. (Johnson, IL) 9750 at 1210 with IS, IDs in EE and other languages, anthem to sign on at 1215. (Moser, PA)

Spain: Spanish National Radio, 9630 at 0500. (Pellicciari, CT) Here and 11880 at 0230 in SS. (Moser, PA)

Swaziland: Trans World Radio, 1955 on 9520 with organ music, hand bell IS, sign off in FF. (Johnson, IL) 11755 at 0430 with IS and sign on, EE ID, religious music. Cuban QRM. (Carson, OK)

Sweden: Radio Sweden, 11705 at 0228 with IS, EE and other language announcements to sign on in non-EE. (Moser, PA)

Switzerland: Swiss Radio International, 6135 at 0200. (Moser, PA) 9535 at 2000 with news. (Johnson,

IL) 9650 at 0228. (Bailey, AR) 9885 at 0400. (Moser, PA) 12035 at 0420. (Carson, OK) 21695 at 1330. (Zamora, ND)

Red Cross Broadcasting Service, 6135 via SRI facilities, 0310 with "Worldwide Activities." (Pellicciari, CT)

Syria: Radio Damascus, 12085 at 2021, woman with news. (Foss, AK)

Tahiti: Radio Tahiti, 15170 with island music at 0515. (Watts, KY) (Not EE, editor)

Taiwan: Voice of Free China, 15345 (via WYFR, editor) at 0438 in CC. (Foss, AK)

Thailand: Radio Thailand, 9655 at 2300. Poor. (Horsfield, England)

Togo: RTV Togolaise, 5046.5 at 0600 with music, FF announcer, soft chime IS. (Johnson, IL)

Turkey: Voice of Turkey, 7110 at 1915 with IS, Turkish music, man announcer in presumed Greek. (Johnson, IL) 9445 at 2300; 0400. (Pellicciari, CT; Bailey, AR)

Tunisia: RTT Tunis, 7475 at 0558 with time pips, ID, news in AA between loud bursts of music. (Johnson, IL) 11550 at 0450 with Koran in AA. (Foss, AK)

Ukraine: Radio Kiev, 17665 at 2200 in Ukrainian or RR, IS with sign on ID and into news. (Carson, OK)

Unidentified: 9540, Sudan?, 1935 with exotic music, maybe AA with an African touch, man talking in AA or Amharic until 1945 when off abruptly. (Johnson, IL) 9500 at 0520 with AA talk, many mentions of Libya and Khadafi, very strong. Heard as early as 2230. (Johnson, IL) (Might be Voice of the Libyan people, clandestine. editor)

United Arab Emirates: UAE Radio, Dubai, 15400 at 0335. (Bailey, AR) 21605 at 1345; 1604. (Moser, PA; Carson, OK)

United States: Voice of America, 8030 at 0336-0400 sign off. All music except for sign off at close. (Peterson, IN) (Tests from Greenville. Editor)

Radio Marti, 6030 at 0705 in SS. (Johnson, IL)

WMLK, 9465 at 0503 with religion. (Carson, OK)

KVOH, 17775 at 0100 with ID, frequency, music in Spanish at sign off. (Carson, OK)

Radio Free New York, via WWCR on 7520 at 0450 (Saturday night US time) with rock, call-ins. (Watts, KY)

Radio New York International via WWCR - 7520 at 0200 (Sunday night local time) with mailbag, IDs, commercials. (Carson, OK)

WINB, 15185 at 2109 with "Talk Back" call-in show. (Carson, OK)

USSR: Radio Moscow, 4975 at 0509 with news. (Johnson, IL) 7345 at 1538, 11930 at 2313, 15155 at 0900 and 15180 at 0431. (Carson, OK) 11840 (via Havana, editor) at 1711, 12050 at 0300 and 21685 at 1657. (Bailey, AR) 17840 at 1305 and 17870 at 1210. (Moser, PA)

Arkhangelsk, tentative, 5015 at 0510 with man and woman, long talk in RR. (Johnson, IL)

Petropavlovsk, 4485 at 0525 with man in RR and pops program. (Johnson, IL)

Radio Peace and Progress, 11980 at 2201, news and commentary. (Carson, OK)

Uzbek SSR: Radio Tashkent, 15470 at 1214 with comments and features. (Moser, PA)

Yugoslavia: Radio Yugoslavia, 11735 at 0120. (Carson, OK) 21715 to 13330 sign off. (Zamora, ND)

Vatican: Vatican Radio, 6185 at 0735 with news and ID. (Johnson, IL) 7125 at 2211 and 21515 at 1211. (Moser, PA)

Venezuela: Radio Nacional, 9540 at 0044 with Latin music, lots of SS IDs. (Johnson, IL)

Radio Tachira, 4830 at 0354 with ID in SS and music to sign off. (Moser, PA) 0630 with two men talking in SS. (Johnson, IL)

That does it! Let the following step forward and take their bows:

Tim Johnson, Galesburg, IL; William Moser, New Cumberland, PA; Kelly Bailey, Midland, AR; R.C. Watts, Louisville, KY; Steve Pellicciari, Norwalk, CT; Kevin Story, Midland, TX; Larry R. Zamora, Grand Forks, ND; A.M. Peterson, Indianapolis, IN; Marty Foss, Anchorage, AK; Mick Horsfield, Denton, England and Bjorn F. Vaage, Granada Hills, CA.

'Til next month—good listening!

For 25 years,
our people have
endured long hours
and tough
working conditions
for no pay.



And 9 out of 10 would
do it again.

TO FIND OUT WHY
call
(316) 263-2100
or write
REACT INTERNATIONAL, INC.
242 Cleveland
Wichita, KS 67214

CIRCLE 18 ON READER SERVICE CARD

CLANDESTINE COMMUNIQUE

WHAT'S NEW WITH THE CLANDESTINES

There continues to be surprisingly little clandestine broadcast activity related to the Gulf situation, although we may well yet see this change. *Huna Al-Kuwayt* is supposed to be broadcasting between 0400-0500 and 1600-1900 using frequencies otherwise occupied by Egypt's Voice of the Arabs service. On shortwave, the Voice of the Arabs uses 9700, 9770, 11685, 11785, 11905, 11980 and 15285 at various times to various target areas. On mediumwave it uses 621 and 1107 kHz. We've seen no reports of *Huna Al-Kuwayt* being heard on shortwave so the broadcasts may be confined to mediumwave only.

In a *New York Times* essay a couple of months ago, columnist William Safire called for the establishment of a *Radio Free Iraq*, to be operated along the lines of Radio Free Europe/Radio Liberty. Safire says the station could be broadcast via VOA transmitters in Greece with Iraqi exiles behind the microphones, telling their countrymen the "real truth" about the Iraqi dictator.

Iraq's rapprochement with Iran seems to have resulted in the dropping of the anti-Iran clandestine which had been aired over various Iraqi radio facilities. The list includes the *Free Voice of Iran*, *Voice of the Crusader* (aka *Voice of the Mojahedin-e-Khalq*) and the *Voice of the Ahwaz Revolution*. A number of anti-Iranian broadcasts remain on the air from other locations.

Although we continue to make zero progress in contacting *Radio SPLA*, it seems someone else has been able to do so, as the station is now being used by a different Sudanese clandestine group. Radio SPLA facilities are now also airing the *Voice of Sudan* which slogans as the "voice of democracy and peace, the radio of the forces of the National Democratic Alliance." This mouthful hasn't been heard yet but it is scheduled from 1800-1900 on 9550 and 11710, all in Arabic. Radio SPLA itself continues to show up fairly often with its 1300-1400 broadcast on 11710. Robert Ross of Ontario noted it at 1325 with local string/percussion music and ID as "Radio SPLA, the Voice of the Sudanese People's Liberation Army." Into Arabic around 1330.

An apparent new anti-Afghanistan station has come on the air. *Afghanistan Mojahedeen Radio*, operating on 6140 and signing on at 0159 in an unstated language, (probably Pahlavi or Dari) looks to be an extremely difficult catch here, as long as it parks in the middle of the crowded 49 meter band.

Clandestine stations connected to the Ethiopian civil war are darn near impossible to hear in North America. But the last few



Colombia is the source of a nightly cat and mouse game between two clandestines in the 6300 area.

months have brought some tentative logs on three of them. *Ethiopian People's Revolutionary Party Radio* was tentatively heard by Ross on 7010 at 0320 to 0330 sign off. The program consisted of talk and local string/percussion music to abrupt closing at 0330. We've seen one or two other reports of this one about this time.

A couple of tentative logs have been taken on the *Voice of the Broad Masses of Eritrea*, though here, again, with quite weak signals. Bob Brown of Pennsylvania caught a weak signal around 0330 on 7492, slightly

variable, and heard a parallel on variable 10021. We've noted something very weak on 7492, also. And we've also seen a tentative logging on the *Voice of the Broad Oromo Masses* at 0400 on 7890, again though, with very weak signals.

Radio Libertas, the Croatian freedom program carried over WHRI, seems to have adjusted its schedule. It has been heard announcing Monday through Saturday to North America on 11790 and to Europe at 1800-1900 "European Mean Time" on

(Continued on page 76)

THE EXCITING WORLD OF RADIOTELETYPE MONITORING

Two mysterious stations were intercepted recently as one appeared to challenge the other for nearly identical HF Radio frequencies and for the same time slot. One station used RTTY, and the other, AM voice.

"C37A" was spotted on 16312.5 kHz at 1825 sending foxes, 10-counts, and RY's, at 100 baud, to "6XM8" (see figure 1). The frequency has been used before by C37A for similar transmissions, and was last noted in the February column. This time, however, while staring at the video monitor for five minutes, hoping to see plaintext messages, I saw that the test transmission had suddenly become quite garbled. C37A's signal was being clobbered by the voice of a Spanish-speaking woman on 16312 kHz, AM, who began delivering a coded message in four-figure groups. Holy baudot, Batman! It was like a scene from Mad Magazine's "Spy vs Spy" column. Her monotoned delivery finally stopped at 1840 to the relief of my ears and of C37A's teletype copy.

I got to wondering about this station, C37A, which I and other RTTY-monitoring hobbyists have intercepted in past years. That tactical callsign looked quite similar to something I saw in CW markers sent by the Canadian military—C13L. Methinks there might be a connection between the two.

Another mysterious station appeared about 90 minutes later, and starred the Spanish-speaking team of "Peca" and "Tito." Using packet radio, Peca ("freckle" in Spanish) sent five-figure groups to Tito, on 13506 kHz (see figure 2). I tuned to the transmission at 2000, and 15 minutes later, the two were signing off. Tito wrote, "OK!555—para QSL/ . . . KLD3," and Peca replied, "RX correcto," ending the transmission.

Their frequency is next door to 13505 kHz, where a previous logging of mine, a few months earlier, showed "Sara Toro" using packet radio to send five-figure-group traffic at 0330. I now have a reminder written to myself to watch for similar packet "spy" radio activity in the future at around this frequency.

During a month of intense flooding in many parts of the country, including the area where I live, I came across a transmission from WUJ3, USACE, Portland, Oregon, that showed the flood level stages of many U.S. rivers (see figure 3). A "local" weather forecast followed, and then some chit-chat with another USACE station, in which WUJ3 said he was "at the U.S. moorings site." This transmission was in the ARQ mode on 16384.3 kHz, and was monitored from 1746 to the signoff at 1759.

Last month's column mentioned an international packet radio bulletin board system found operating on 26838 kHz. A similar

```

TO: TITO FROM: PECA (I) ok fue que rpeti el 3 dos vases
TO: PECA FROM: TITO (I) OK ADT,,
TO: TITO FROM: PECA (I) 11905 94 5
TO: TITO FROM: PECA_S (I)
TO: TITO FROM: PECA (I) 11905 94 50
.....
< 459 >
21896 27093 40320 61710 56350 87854 85182 151
TO: TITO FROM: PECA (I) 627 81557 61196 70264 48471 77072
76177!66336 26308 79402 +1992xV
TO: TITO FROM: PECA (I) 87829 59101 72445 22919 65660
13961 33693 38371 68196 73456 98185 12548 73557 66132 05269
22913 08347 36429 06537 34312 8307
TO: TITO FROM: PECA (I) 8822286 80733 19441 06681
63766 47535 04270 05995 28983 67220 09324 88337 24565 77425
61554 94671 95097 21662 95376 53544 32
TO: TITO FROM: PECA (I) 11905 94 50
.....
<
TO: TIL/ FROM: PECA (I) 627 81557 61196 70264 4847q 77072
76177 66336 26308 79402 30982 45401 24751 33287 39408 97466
16476 74729 95517 22347 09118
TO: TITO FROM: PECA (I) 8 12286 80733 19441 06681
63766 47535 04270 05955 *8983867220 09324 88337 24565 77425
61554 94671 95097 21662 95376 53544 32
TO: TITO FROM: PECA (I) 627 81557 61196 70264 48471 77072
TO: TITO FROM: PECA (I) 878R:
TO: TITO FROM: PECA (I) 8 12286 80733 19441 06
TO: TITO FROM: PECA (I) 8
TO: TITO FROM: PECA (I) 470 05382 94910 44000
71127 86200 57760 31903 12954 26189 01593 30486 80301 96853
96239 05770 75910 8

```

Figure 1

system has also been found on 27538.5 kHz and it seemed to include Europe, the United States, and maybe Africa.

Both BBS systems are not run by utility stations, but by persons similar to amateur radio operators or CB'ers. Their callsigns seemed to reflect the country each lived in.

Some callsigns that I saw one Saturday afternoon at around 1630 UTC were FRA1BX, FRA2BX, FRA3AC, FRA3AZ, FRA3DK, FRA5BX, all of which I presume to be from France, hence the FRA part of the callsigns. Then there was AU2BSW, possibly Austria; FIN1VE and FIN5AC, possibly Finland; and REU1XX, possibly Reunion. There also was SP7AB, SP7AB-2, and SP7AB-4, which I guess was from Spain.

U.S. stations monitored were USA1AA, USA1AG, USA1AR in Delaware, and USA1AT, which calls itself "the border station: Arizona USA." Other American stations were seen, although they appeared to be operating separately from the international network. There was FT466, FT115, FT256, and FT444. FT466 announced its QTH as Salt Lake City, UT, and used both 45-baud and packet modes to talk to FT466. When using 45-baud RTTY, FT466 used a longer callsign of FT5466 and FT115 used FT1115.

Rereading my Oct. 1990 column recently, I saw that I had written about some apparent ARQ transmissions seemingly running at 200 baud, and at frequency shifts other than 170 Hz. Although I came across many stations using that mode for a long time, I never was able to get any text output from my M-6000 decoder, or my Swiss-made decoder, even though those stations seemed to be chirping away like crazy. Was something wrong with both of my decoders, I wondered?

Well, last September, four months after writing that column, I purchased a German RTTY decoder, one that was able to decode many of the latest in synchronous teletype modes. Right away I found that the 200-baud ARQ transmission I thought I was monitoring was really ARQ6-90, which is at 200 baud. So the speed counter on the M-6000 was correct! But to my ears, the signal sounded similar to SITOR-A (ARQ) and I was unaware of ARQ6-90 until I got the new decoder.

Now I was also rapidly identifying all those stations that were marked in my personal logbook as being an "unidentified TTY mode," or "ARQ/425." They were using DUP-ARQ, POL-ARQ, SI-ARQ, and SWED-ARQ, all which resemble SITOR-A

NEW ORLEANS	3.2	0.0	3.3	2.9	2.9
ARKANSAS LITTLE ROCK		N	N		
PINE BLUFF		N	N		
COLDWATER SARAH	0.3	-0.8			
TALLAHATCHI LAMBERT	16.2	-0.1			
LOCOPOLIS	23.0	-0.2			
SWAN LAKE	14.9	-0.2			
YALOBUSHA WHALEY	14.6	-0.3			
YAZOO GREENWOOD	17.1	-0.2			
BELZONI	5.5	-0.2			
YAZOO CITY	13.6	-0.3			
BIG BLACK WEST	2.5	0.0			
BOVINA	6.4	0.0			
SUNFLOWER SUNFLOWER		0.1	0.0		
PEARL BOGALUSA		8.0	0.0		
PEARL RIVER	4.3	0.0			
L?D 3	N	N			
QUACHITA ARKADELPHIA	7.1	3.2			
CAMDEN	7.2	-0.8			
CALION L?D HW	77.0	0.0			
CALION L?D TW	66.0	-0.5			
FELSENTHAL HW	65.0	0.0			
FELSENTHAL TW	54.0	-0.2			
MONROE	21.3	0.0			
COLUMBIA HW	52.0	0.0			
COLUMBIA TW	34.9	0.1			
BLACK JONESVILLE HW	34.0	0.0			
JONESVILLE TW	11.8	-1.5			
ACME	10.9	-1.1			
RED FULTON	3.0	0.4			
SHREVEPORT	8.6	-0.2			
GRAND ECORE	9.8	0.1			
ALEXANDRIA	20.3	-0.1			
OVERTON L?D HW	64.0	0.0			
OVERTON L?D TW	43.0	0.1			
L?D NO. 1 HW	40.0	0.0			
L?D NO. 1 TW	15.2	-0.3			

E=ESTIMATED N=NOT REPORTED P=POOL STAGE
N/A=NOT APPLICABLE L=LANDSIDE R=RIVERSIDE HW=HEADWATER TW=TAILWATER
LOCAL WEATHER FORECAST: TODAY..WINDY WITH SCATTERED SWERS AND
THUNDERSTORMS HIGHS 75 TO 80...A LAKE WIND ADVISORY IS IN EFFECT
FOR SOUTH WINDS AROUND 20 MPH AND GUSTY, CHANCE OF RAIN 30 PERCENT.
TONIGHT.. SHOWERS AND THUNDERSTORMS LIKELY. LOWS 65 TO 70. WINDS
15 TO 20 MPH.CHANCE OF RAIN 60 PERCENT...WEDNESDAY.A GOOD CHANCE
OF SHOWERS AND THUNDERSTORMS ..MMAINLY IN THE MORNING AND TURNING
COOLER..HIGHS IN THE LOW AND MID 70UPS EARLY BUT FALLING INTO THE
50S BY LATE AFTERNOON..SOUTH WINDS 15 TO 20 MPH SHIFTING TO THE
NORTH BY AFTERNOON. CHANCE OF RAIN 50 PERCENT.....

NNNN
AND YOU SHOULD HAVE GOT A RFECT COPY K
+?DE WUJ3 RGR RGR SURE DID. I CAPTURED TO PRINTER AND A FILE SO I
COULD PRINT THE WHOLE TING OUT +?
RGRGRGR DID YOU BY CHANCE TRY TO CALL WUJ-5 BY
LANDLINE AND SEE IFN HE FORGOT TO MEET YOU K K
+?
DE WUJ3 NO, I AM AT THE U.S. MOORINGS SITE AND THE BOOK HAS
THE WRONG NUMBERS IN THE OPERATING MANUAL SO I NEED TO TAKE
THE BOOK BACK TO MY OFFICE DOWNTOWN AND UPGRADE IT. I WILL
TRY CALLING THEN THENEEEE THEM NEXT WEEK. USUALLY HE IS ON
TIME BUT EVEN WALLA WALLA DIDNT SHOW UP ON 6MHZ +?
44 9(B 28))35 6907 9 -, 23, -, 8
YOU EVER GET THEM MAKE SURE THAT WE KNOW HERE
AND MAYBE BY CHANCE, WE CAN HEAR THEM
WILL LET YOU GO..HAVE A NICE DAY K K
+?DE WUJ3 RGR SURE WILL CALL YO LANDLINE NEXT WEEK WHEN
WE TALK O THEM. YOU CAN DO RADIO CHECK WITH THEM ALSO. MAYBE
YOU MIGHT WANT TO INVITE THEM TO THE DIVISION NET ON FRIDAYS
AND SEE IF THEY WILL SHOW UP.O. IT IS PRETTY EARLY THIR TIME. ABOUT
5 OR 6 AM WHEN THE DIVISION NET STARTS SO I DONT KNOW IF ANYONE
IS THERE. OKCUL THANS TOEEE FOR THE TEST. I ALMOST FORGOT
HOW TO DO AMDEEE AMTOR. SEE YOU LATER BYE
73 AR

Abbreviations Used In The RTTY Column

AA	Arabic
ARQ	SITOR mode
BC	Broadcast
EE	English
FEC	Forward Error Connection mode
FF	French
foxes	"Quick brown fox ... "test tape
GG	German
ID	Identification/ied
MFA	Ministry of Foreign Affairs
nx	News
PP	Portuguese
RYRY	"RYRY ... "test tape
SS	Spanish
tfc	Traffic
w/	With
wx	Weather

recycle their used TTY paper, for this was a sure paper waster (Ed.).

6416: WLO, Mobile R., AL, w its BC sked in FEC at 2359 (Ed.).

6818: "DOS" w manually typed RYRY at 0214, 75 baud, foll at 0219 by "Now is the time . . ." and at 0223 w 973 de DOX INT QRK K. Sent more RYRY at 0231, foll at 0236 w "RGR U B same R U ready to go uppers (and) what segment R U on (and) RGR RGR I got U tks C U in uppers." Then began lengthy encryption at 0239 (Ed.).

6824: GHH, Jamestown Meteo, St. Helena, w coded wx, 0154-0200, 50 baud (Ed.).

6830: RDW72, Khabarovsk Meteo, USSR, w coded wx, 50 baud at 1343 (Ed.).

6909.3: U.S. Army MARS sta AAR3NAA w MARSgrams to AAA3USA, 300-baud packet at 1352 (Ed.).

6911: U.S. Army MARS sta AAAOUSA w mrgs for all western area MARS members & stas, FEC at 0414 (Ed.).

6996: U.S. Army MARS sta AAT7USF, instructing AAR70A in the format for sending MARSgrams, ARQ at 0138 (Jerry Domokur, OH).

7402.5: JMG3, Tokyo Meteo, Japan, w coded wx, 50 baud at 1359 (Ed.).

7428.5: Telam, Buenos Aires, Argentina, w nx in SS, 50 baud at 0049 & 0217 (Dallas Williams, CO).

7460.5: Lusaka Aero, Zambia, w coded aero wx at 0308, foll at 0330 w "Zambia Morning Weather Report and Forecast" in EE, 50 baud (Ed.).

7535: NNN0GKF relaying MARSgrams from USN MARS sta NNN0NYW & USMC MARS sta NNN0MEF, both w Operation Desert Shield in Saudi Arabia, to NNN0NAV, for delivery to Midwest addresses. Was 75 baud at 1732 (Ed.).

7589: U.S. Army MARS sta AAR5USB relaying MARSgrams from AEM1UFB, Bamberg, Germany, to AAR5CCC, 300-baud packet at 1405 (Ed.).

7625: HZN47, Jeddah Meteo, Saudi Arabia, w coded wx at 0157, 100 baud (Ed.).

7626: TZH, ASECNA, Bamako, Mali, w RYRY at 0213, 50 baud (Williams, CO).

7675.2: "5TA.DINF," possibly Mexican mil., w the military record of a soldier, who apparently was up on disciplinary charges. Was in SS and in ARQ, 0045-0057 (Ed.).

7685.5: NNN0YMN, U.S. Navy MARS, QTH unknown, w foxes & RYRY, 75 baud at 0116 (Bilodeau, IL).

7714: TJK, ASECNA, Douala, Cameroon, w RYRY at 0209, 50 baud (Williams, CO).

7715: 7715 RCU71, Novosibirsk Meteo, USSR, w coded wx, 50 baud at 0153 & 1437 (Ed.).

7760: RGH77, Arkhangelsk Meteo, USSR, w coded wx, 50 baud at 0416 (Ed.).

7700: Irkutsk Meteo, USSR, w coded wx, 50 baud at 0116 (Ed.).

7717.7: AAT6PR, U.S. Army MARS, Tulsa, OK, w MARSgrams from soldiers' homes sent to AAV6AO for further relay to the 101st Airborne Div., w the Operation Desert Shield forces in Saudi Arabia. Was ARQ at 1717 (Ed.).

7890: ROQ3, Novosibirsk Meteo, USSR, w coded wx, 50 baud at 0147 (Ed.).

7954.5: LRN85, DyN, Buenos Aires, Argentina, w nx in SS, 75 baud at 0125 (Ed.).

7992.5: Several USN MARS stas w MARSgrams & tfc, 300-baud packet at 0136 (Ed.).

Figure 2

in sound. For the past couple of months, I have been noting these loggings in the RTTY Intercepts portion of this column. On top of that, I came across a station, while writing this month's column, that was using ARQ-N/96. Details of that transmission are given at 16337 kHz in the RTTY Intercepts section, which begins now.

RTTY Intercepts

3190.5: A Michigan RTTY net of USN MARS sta xmtng at 0004, 75 baud. ID's included NNN0UXG, NNN0BOM, and NNN0ALS (Ed.).

4004.5: LR02, Telam, Buenos Aires, Argentina, w nx in SS at 0010, 50 baud (Ed.).

5449: Un-ID U.S. mil., w AP sports nx at 0253, FDM 75 baud (Hal Bilodeau, IL).

6372.5: GYU, Royal Navy, Gibraltar, sending only "DE GYU" on every line, 75 baud at 0300. Hope they

TIN CTO BIET CANH SAT DA DUMO GAY VA MOI CAY DE GIAI IAN NHUNG NGAOI BIEU TI H. NHUNG NGUOI BIEU TIN DA NEM DA VAO ANH SAT VA CANH SAT DA NO SUNG DE TRA DUA. CO 9 NGUOI THIET MANG VA 30 NGUOI KHAC BI THUONG.

NIU DI-LAN_: AFF 90EN-LINH-TON_2-11) -HOM NAY, THU TUONG MOI CUA NIU_DI-LAM JIM BOLGER DA LAM LE TUYEN THE CUNG VOI NOI CAC GOM 20 NUO CUA ON_ VA 5 BO TRUONG LIEN HIEP.

NDI CAC MOI DI DINH SE TIEN HA H MOT CUOC HOP KHONG CHINH THUC VAO TOI NAY VA PHIEH HOP TAM VIEC DAU TIEN SE DUOC TIEN HANH VAO NGA 5-11.

TRUNG DOND : THX 9ABU DHABI 1-11) - HOM NAY, CAC HIEU V_DNG QUOC ARAP_THONG NHAT (UAE) BAC BO BATH Y MOT GIAI PHAP NAO CUA CUOC KHUNG HOANG VUNG V_NH O NGOAI KHUON KHO CUA CAN NGHI QUYET CUA CUOC HOP CAP CAO ARAP VA CUA_HOI DO_G BAD AN LHQ.

TSYEN BO TREN DO THA TURONG NGOAI GIAO CAC T_EU VUONG_Q_OC ARAP S.AL N_HYAN DIA RA DE CHINH THUC FAP LA MOT_DE NGHI CUA LX YEU CAU TO CHUC MOT CUOC HOP TROND NOI BO CAC NUOC ARAP DE TIM NBT GIAI PHAP TOA_B_NH DOI VOI CUOC KHUNG HOANG NAY ./.
Hj S --HET---

U
104920 JANBO
NNNN C_B
FOR VNA BEIJING
P/17(2-11)

VIETNAM NEWS AGENCY

SECOND T
ANSMISSION - NOVEMBER 2, 1990 :14:45 GMT)

ZCZC

90.016 - CHAMBER MUSIC COMPOSITION COMPETITION CONCLUDED

HANDI VNA NBV.2 - A CEREMONY WAS HELD H.RE YESTERDAY BY THE VI_TNAM M_SICIANS'_ASEOCIATION TO PRESENT PRIZES TO TEN WINNERS OF THE 1990 NATIONAL CHAMBER MUSIC COMPOSITION COMPETITITN. THE COMPETITION DREW THE PARTICIPATION OF _S MUSICIANS THROUGHOUT THE COUNTRY.

TWO SECOND PRIZES WERE PRESENTED TO A SONATA FOR STRING QUAGTETTE BY HOANG CUONG OF THE HO CHI MINH CITY CONSERVATOIRE, AND A QUINTETTE BY NGUYEN TROND DAI OF THE HANDI ART, CULTURE AND MUSIC COLLEGE.

THE ORGANIZING COMMITTEE ALSO CONFERRED FOUR THIRD PRIZES AND FOUR CONSTLATION PRIZES ONMUSICIANS OF DIFFERENT ART ENSEMBLE AND MUSIC COLLEGES, NO ONE WON THE FIRST PRIZE OF THE CONTEST. ./.
NNNN

5
10031 JANBO
NNNN
HSF
ZCZC
VNA000 3 TTY HAN TTA 2967

VNA022 .0171

YZCZC

90.017 - MAIN EVENTS IN OCTO____K
HANDI VNA OCT.2

Figure 4

w nx in Ff at 1246, 50 baud (Ed.).

14461.5: Un-ID w foxes & 10 count, 1313-1350, 75 baud (Ed.).

14470: Un-Id w 5L grps w 11177 . . . in the header, 50 baud, 0245-0249. Previously attributed to the GDR, when it existed, but now whozit? (Williams, CO).

14478.5: OEC, MFA, Vienna, Austria, w msgs in GG & 5L grps, 1458 to past 1544, SI-ARQ/96 (5 characters) (Ed.).

14488.5: OEC, MFA, Austria, w APA nx in EE to Lisbon, SI-ARQ/96 (5 characters) at 1507. A couple of weeks later, found at 1513 w 6-character xmsn, sending a 5L msg, APA nx in EE, & msgs in GG. S/off 1530 w "clear" (Ed.).

14531: Many East & West Coast USAF sta. found throughout the day using 300-baud packet (Ed.).

14531.5: "P6Z," MFA, Paris, France, w 5L-gpd msgs, 1309 to past 1415, ARQ6-90/200 (Ed.).

14573: 5AQ79, Jana, Tripoli, Libya, w nx in AA, 50 baud at 1432 (Ed.).

14597.2: SPW, Warsaw R., Poland, w PAP nx in Polish, FEC at 1423 (Ed.).

14599.5: Un-ID w a msg in AA, ARQ, 1323-1342 (Ed.).

14760: BAT93, Xinhua, Beijing, China, w nx in EE at 0412, 50 baud (Williams, CO).

14766.4: ZLK32, Weedons Meteo, New Zealand, w coded wx, 75 baud at 0304 (Williams, CO).

14818.8: Un-ID U.S. mil., w AP nx at 2252, FDM 75 baud (Bilodeau, IL).

14857.8: MKD, RAF, Akrotiri, Cyprus, w RYI's & foxes, FDM 50 baud at 2132 (Williams, CO).

14923: BAP44, Xinhua, Beijing, China, w nx in EE at 0251, 75 baud (Williams, CO).

14936: NNN0MBO, USMC MARS, w "Afloat Net Traffic System (ANTS) mailbox NOMBO (NMBO) is on line." Was FEC at 1550 (Ed.).

14964: "RFFXL," French Mil., Beirut, Lebanon, w plaintext tfc at 1555, ARQ-E/72 (Ed.).

15751: CNM66X2, MAP, Tanger, Morocco, w nx in EE, 50 baud at 1310, and in FF at 1700 (Ed.).

15765.8: Un-ID in Mexico w a wx rpt in SS, 75 baud at 1456-1500. Copies of rpt to Tijuana, Mexicali, Tecate, El Aguaje de la Tuna, & San Quintin. Tuned to this freq the next day to try to get an ID, but was not on the air (Ed.).

15796.5: JWT, Stavanger Navrad, Norway, w s/off msg, "De JWT ja den er god qru her for oeyeblikket," ARQ at 1528 (Ed.).

15856.5: MFA, Bonn, Germany, w encryption to Havana at 1743, ARQ-E/96, foll by a s/off msg in GG at 1802 (Ed.).

15935: SUA291, MENA, Cairo, Egypt, w nx in EE & FF, 50 baud at 1809 (Ed.).

16006.6: Egyptian Embassy, Paris, France, w telexes in AA & FF + a msg w 19 5L grps, to Cairo, and a

relay of a telex in FF from Cotonou, Benin. Was ARQ at 1702 (Ed.).

16015: MFA, Sofia, Bulgaria, w 5F grps, crypto after DDDDD, & text in Bulgarian, all marked "za Vaxava" (for Warsaw), 75 baud, 1218-1255 (Ed.).

16066.8: IRO30, ANSA, Rome, Italy, w RYRY/QRA de "IRU/58 kHz 22892.1 IRJ/50 kHz 12083" at 1700, 50 baud, foll by nx in EE at 1705 (Ed.).

16106: FZM62, DIPLO Paris (Noumea, New Caledonia relay), w nx in FF at 0400 & 0700, 50 baud (Ed.).

16107.5: HBD20, MFA, Berne, Switzerland, w 5F & 5L grps, and a circular in Ff, ARQ at 1355. Appeared to be same type tfc as on 16111.2, but the time marked was 2:10 earlier, i.e., 1145 instead of 1355 (Ed.).

16111.2: HBD20, MFA, Berne, Switzerland, w 5F & 5L grps, and a circular in Ff to several embassies, ARQ at 1313 (Ed.).

16117.3: Un-ID sta in SS w bank statements, including deposits & withdrawals, and coded wx compiled by Santa Maria Aero, Azores. Was ARQ at 2253-0100, and idling thereafter to past 0730 (Ed.).

16119: CLP1, MFA, Havana, Cuba, w prensamin-rex & tfc in SS, 50 baud at 0647 (Ed.).

16119.8: HBD20, MFA, Berne, w nx in GG at 1321, ARQ, foll at 1341 w 5L grps to "Ambassade Mexico" (Ed.).

16143.5: "RFLI," French Navy, Fort de France, Martinique, w unclassified tfc in FF, ARQ-E3/192 at 2017 (Ed.).

16152.8: Un-ID U.S. mil. w AP nx, FDM 50 baud at 0247 (Williams, CO).

16154: TAD, MFA, Ankara, Turkey, w telexes in Turk to Rome, Paris, Bonn, & other embassies. 100 baud, 1820 to 1837 (Ed.).

16190: RGW26, Tass, Moscow, USSR, w nx in FF at 0712, 50 baud (Ed.).

16202: Guessing Cairo Meteo, Egypt, w occasional handtyped coded wx, 50 baud at 1857, and sporadically thereafter, as the sta is mostly idling (Ed.).

16210: MFA, Jakarta, Indonesia, w tfc (nx?) in Indonesian, ARQ, 1421-1440 (Ed.).

16246.6: VOA, Tangier, Morocco, w RYRY to Greenville, NC, FDM 75 baud at 1441 & // 16248 (Ed.).

16302: "DFZG," MFA, Belgrade, Yugoslavia, w nx in Serbo-Croat, 75 baud at 1524 (Harold Manthey, NY).

16304: Un-ID w crypto after DDDDD, FEC-A/144 at 1602, foll by op msgs w Q-Codes at 1612, then idling while receiving tfc from another sta, most likely on another freq. S/off 1637 w OK OM hr QSL all 7373 SK (Ed.).

16312.5: "C37A" w RYRY, foxes & 10-count to "6XM8," 1825-1848 and again at 1855, 100 baud (Ed.).

16315.9: KNY25, Romanian Embassy, Washington, DC, w test tape, 75 baud at 1609. An unprintable character, possibly the "bell" one, was sent btwn each character before the ID (Williams, CO).

16337: Italian Embassy, Baghdad, Iraq, w 5L msgs & msgs in II to MFA, Rome, ARQ-N/96 at 1700, until s/off at 1745 (Ed.).

16361.6: Egyptian Embassy, Libreville, Gabon, w 5L msgs & tfc in EE & FF to Cairo, ARQ at 1633 (Ed.).

16384.3: WUJ3, U.S. Army Corps of Engineers, Portland, OR, w flood stages of U.S. rivers and a wx forecast for the Portland area. Was ARQ, 1746-1759 (Ed.).

16676.5: YJXK3, the Vanuatu cargo ship "Paxi Rex," w telex tfc at 2105, ARQ (Ed.).

17010: URD, Kaliningrad R., USSR, w telegrams, 50 baud at 1521 (Ed.).

17020: UDK2, Murrnansk R., USSR, w telegrams at 1523, 50 baud (Ed.).

17024: SAB83, Goeteborg R., Sweden, w telex tfc, ARQ at 1524 (Ed.).

17226: UFN, Novorossisk R., USSR, w a telex in Cyrillic, FEC at 1636, foll by a 4F msg & nx in Cyrillic until 1659 (Ed.).

17414: Possibly RFFA, Defense Ministry, Paris, France, w 5L msgs 1725-1935, ARQ-E/72 (Ed.).

17443: BZG48, Xinhua, Yuryumqi, China, w nx in FF, 50 baud at 1536 (Williams, CO).

17454.5: Un-ID French mil. or diplo sta., w msgs in 5L gps and in FF, ARQ6-90/200, 1522 to 1610 (Ed.).

17502: AAA6USA, U.S. Army MARS, Fort Sam Houston, TX, w MARSgrams relay to AAA3USA, 300-baud packet at 0025 (Ed.).

PRESENTING
**CABLE TV
DESCRAMBLERS**
***** STARRING *****
JERROLD, HAMLIN, OAK
AND OTHER FAMOUS MANUFACTURERS

- FINEST WARRANTY PROGRAM AVAILABLE
- LOWEST RETAIL / WHOLESALE PRICES IN U.S.
- ORDERS SHIPPED FROM STOCK WITHIN 24 HRS.
- ALL MAJOR CREDIT CARDS ACCEPTED

FOR FREE CATALOG ONLY **1-800-345-8927**
FOR ALL INFORMATION **1-818-709-9937**

PACIFIC CABLE CO. INC.
7325 1/2 RESEDA BLVD., DEPT. 1161
RESEDA, CA 91335

Please send all reader inquiries directly.

World Probe
\$29.95 World Band Scanner Antenna

- + S3 P & H
- Cuts Noise • Improves Reception • Indoors or Out •
- Works with all World Band Portables and Scanners •
- Sleek 6-ft Probe with Integral 25-ft Low-Loss Shielded Feedline •
- Fully Insulated and Weather Sealed • Decorator White Design •

AntennasWest Box 50062-P **FREE** Storage Pouch
801 373 3425 Provo, UT 84605 & Universal Connector Kit

Circle 5 on Reader Service Card

THE RADIO COLLECTION
Get the Lowdown with the Hottest Inside Books!

"LATEST INTELLIGENCE" \$16.95
"DIRTY LITTLE SECRETS" \$21.95

Where Radio Is Fun Again!

PO Box 149, Briarcliff Manor, NY 10510

Circle 143 on Reader Service Card

**YOU
AINT HEARD
NOTHIN...YET!**

Since 1967, CRB Research has been the world's leading publisher and supplier of unique hobby and professional books and information including:

- Scanner Frequency Guides
- Shortwave Frequency Guides
- Military/Federal Communications
- Broadcast Station Registries
- Undercover Communications
- Survival Communications
- Covert Operations
- Electronic Espionage
- Surveillance
- Monitoring
- Cryptography & Codes
- Bugging
- Wiretapping
- Communications Antennas
- Electronics & Projects
- Computer Technology
- & Other Related Topics!

Ask For Big Free Catalog!

CRB RESEARCH

P.O. Box 56 Commack, NY 11725

Circle 144 on Reader Service Card
72 / POPULAR COMMUNICATIONS / April 1991

VAAR EGEN VERKSAMHET. DETTA
AER ARTFRAEMMANDE OCH OACCEPTEBELT. SAEGER CARL THAM.

**FLYKTINGFIENTLIGA
FOERSLAG AVVISADES**

.....
INGEN ENSKILD FRAAGA HAR LOCKAT SAA MAANGA MOTIONAERER SOM
FLYKTINGPOLITIKEN VID DEN MODERATA PARTISTAEMMAN I
LINKOEPIING. SAMMANLAGT 25 MOTIONER HADE LAEMNATS IN, OCH
FLERA AV DEM YRKADE PAA KRAFTIGA BEGRAENSNINGAR. SOMLIGA
MOTIONER HADE OCKSAA INSLAG AV RASISM.
MODERAT POLITIK SKA GRUNDAS PAA RESPEKT OCH TOLERANS FOER
MAENNISKOR. FLYKTINGPOLITIKEN FAAR DAERFOER ALDRIG VAENDAS
MOT DEM SOM FLYR FRAAN NOED OCH POLITISKT FOERTRYCK.
RIKSDAGSMAN GUNNAR HOEKMARK UNDERSTROEK DETTA MED STOR
HETTA NAER FLYKTINGPOLITIKEN DISKUTERADES, KONSTATERAR
DAGENS NYHETER PAA SOENDAGEN.

HEMLIG ARME I SVERIGE

.....
EN MOTSVARIGHET TILL DEN HEMLIGA VAEPNADE ORGANISATIONEN
SOM NYLIGEN AVSLOEJATS I ITALIEN HAR OCKSAA FUNNITS I
SVERIGE.
DET HAEVDAR FOERRE CIA-CHEFEN WILLIAM COLBY I EN INTERVJU
MED DEN ITALIENSKA VECKOTIDNINGEN L 'ESPRESSO, RAPPORTERAR
SVENSKA DAGBLADET PAA MAANDAGEN.

VAEDRET

.....
SOLIGT. NAAGON PLUSGRAD

- END OF MESSAGE

- END OF TRANSMISSION

Figure 5

- 17522:** 5KM, Bogota Navrad, Colombia, w RYRY & SGSG at 2349, foll by IANTN tfc to PWX, 75 baud (Ed.).
- 17524.5:** Un-ID meteo sta w coded wx, 50 baud at 1630. To FAX mode, 1704-1737, 60 rpm, then back to RTTY at 1737. Steadily increasing QRM made difficult the printouts of the FAX/RTTY xmsns. Continues w wx until 2237, pauses until 2312, then runs in FAX mode until 2332. Another long pause, foll by RTTY xmsn at 2350 (Ed.).
- 17528:** Un-ID w RYRY at 1322, & 5F grps, 1323-1326, 75 baud (Ed.).
- 17540:** NBA, USN, Balboa, Panama, w IAWG-90 tfc at 0414, 75 baud (Williams, CO).
- 17590:** 5YD8, Nairobi Aero, Kenya, w aero wx at 1825 & 0030, 100 baud (Ed.).
- 17610:** YZJ8, Tanjug, Belgrade, Yugoslavia, w nx in SS at 1836, 50 baud. Getting clobbered by WYFR-Family Radio, Oakland, CA, which had a religious pgm in FF on 17612.5. YZJ8 is beamed to New York City and Buenos Aires, which made matters worse (Ed.).
- 18028.9:** PTT, Lubumbashi, Zaire, w telex tfc in FF to Brussels, Belgium, 50 baud at 1523 (Williams, CO).
- 18035:** JAT28, Kyodo, Tokyo, Japan, w nx in EE, 50 baud at 0256 (Williams, CO).
- 18037.4:** Un-ID sending BQQQ selcal, ARQ at 1414 (Ed.).
- 18042.5:** Un-ID ending msg w 5F grps, foll by s/off in CW. Was 75 baud at 1313 (Ed.).
- 18050:** RQV70, Tass, Moscow, USSR, w nx in FF, 50 baud at 1311 (Ed.).
- 18055:** "DFZG," MFA, Belgrade, Yugoslavia, w plaintext tfc at 1522, 75 baud (Williams, CO).
- 18065:** CLP1, MFA, Havana, Cuba, w prensaminrex, 50 baud at 1421 (Ed.).
- 18160:** RTB25, Tass, Moscow, USSR, w nx in FF at 1308, 50 baud (Ed.).
- 18238:** ZRO4, Pretoria Meteo, RSA, w coded wx at 0407, 75 baud (Williams, CO).
- 18357:** CME329, Czech Embassy, Havana, Cuba, w 5L grps, 75 baud at 1510 (Williams, CO).
- 18416.5:** MFA, Jakarta, Indonesia, w handtyped tfc slugged "Deplu Jakarta," 50 baud at 1602 (Williams, CO).
- 18496:** CNM8OX11, MAP, Rabat, Morocco, w nx in EE at 1407, 50 baud (Manthey, NY).
- 18503.5:** "RFFA," Defense Ministry, Paris, France, w tfc in the clear at 1717, ARQ-E3/192 (Ed.).
- 18526.2:** Un-ID w ARQ tfc in possibly FF at 1844. Tfc was severely garbled due to interference from KKN50 CW marker on 18525.
- 18533.5:** Italian Embassy, Moscow, USSR, w 5L msgs to MFA, Rome, ARQ at 1330 (Ed.).
- 18769:** "P6Z," MFA, Paris, France, w msgs to an embassy, 1535-1634, FEC-A/192 (Ed.).
- 18854:** TAD, MFA, Ankara, Turkey, w telexes in Turk to London, 100 baud, 1610-1622 (Ed.).
- 18810:** SAM99, Swedish Embassy, Quito, Ecuador, w telexes in Swedish to MFA, Stockholm. SWED-ARQ at 1525. SAM, MFA, Stockholm, w nx in Swedish, FEC, at 1648 (Ed.).
- 18812:** SAM, MFA, Stockholm, w nx in Swedish (see figure 5) at 1657, FEC (Ed.).
- 18966.7:** "RFHJ," French Navy, Papeete, Tahiti, w 5L msg at 1516, and "controle de voie" at 1517 & 1534, ARQ-E3/96 (Ed.).
- 18988:** JAX78, Tokyo, Japan, "Gaimu" ID + QRA, RYRY & foxes, 50 baud at 0359 (Bilodeau, IL).
- 19026.5:** AEM1USA, U.S. Army MARS, Lohnsfeld, Germany, w MARSgrams to AAA3USA, Ft. Meade, MD. Was 300-baud packet at 1231 (Ed.).
- 19027:** PWX, Brasilia Navrad, Brazil, w RYRY & SGSG to CXR along w op msgs, 75 baud at 1855 (Ed.).
- 19127:** RNC21, Tass, Moscow, USSR, w nx in SS at 1502, 50 baud (Williams, CO).
- 19235:** RWW70, Tass, Moscow, w nx in FF at 1459, 50 baud (Williams, CO).

19463: SUNA, Khartoum, Sudan, w nx in FF, 50 baud at 1634 (Ed.).

19980: EPJ2, IRNA, Teheran, Iran, w nx in EE, 50 baud at 1605 (Paul Scalzo, PQ).

20068: "PHWR," Hickam AFB, HI, w coded wx at 0235, 75 baud (Williams, CO).

20085: ISX20, ANSA, Rome, Italy, w RYRY, 50 baud at 1801 (Manthey, NY); and wnx in FF, 50 baud at 1821 (Bilodeau, IL).

20103: AEM1USA, U.S. Army MARS, Heidelberg, Germany, relaying MARSgrams from AEM1QF & AGA7RM in Germany to AAA3USA, 300-baud packet at 1930 (Ed.).

20107.5: AEM1USA, U.S. Army MARS, Heidelberg, Germany, relaying MARSgrams from AEM3 . . . units w Operation Desert Shield in Saudi Arabia to AAA3USA. Was 300-baud packet at 1810 (Ed.).

20130: "DFZG,," MFA, Belgrade, Yugoslavia, signing off at 1543, 75 baud (Ed.).

20139: "DFZG," MGA, Belgrade, w crypto after VCVCVC, 1554-1615, 75 baud (Ed.).

20402: CCS, Santiago Navrad, Chile, w RYRY & SGSG, 75 baud at 1740 (Bilodeau, IL & Williams, CO).

20662: North Korean Embassy, QTH unknown, w 5F grps, 50 baud at 0350 (Williams, CO).

20742: "GMN," un-ID sta, w RYRY at 1747, foll by a 5L-grpd msg ending w QRU SK s/off at 1750. Was 50 baud (Ed.).

20822: "RFFXI," French Mil., Bangui, Cent. African Rep., w "non protege" tfc in Ff, ARQ-E/72 at 1538 (Ed.).

20837.5: Un-ID Cuban diplo w a circular in SS, 50 baud at 0344 (Williams, CO).

20872: AGA8HI, USAF MARS, Hickam AFB, HI, w relay of MARSgrams from MARS stas in Japan. Was 75 baud at 1754 (Ed.).

21853.5: French Embassy, Fort de France, Martinique, relaying 5L msgs from MFA, Paris to Bogota, Colombia, ARQ6-90/200, 1354-1400 (Ed.).

22581: Y5M, Ruegen R., Germany, w ARQ telex tfc at 1555 (Ed.).

22854: "RFGW," MFA, Paris, France, w 5L msgs to many embassies, ARQ6-90/200 at 1355. "RFLI," French Navy, Fort de France, Martinique, w 5L msgs at 1442, same TTY mode (Ed.).

22888: DFZG, MFA, Belgrade, Yugoslavia, w crypt to after XPXPXP, 75 baud at 1505, foll by nx in Serbo-Croat at 1527 (Ed.).

22912.5: "RFVI," French Navy, Le Port, Reunion, w "controle de voie," at 1530, ARQ-E3/100 (Ed.).

22947: MFA, Warsaw, Poland, w nx in Polish, POL-ARQ, at 1445. Ended xmsn 1458 in midst of text, at which time another RTTY sta could be heard on this freq. Warsaw returned briefly at 1500 w 3 more paragraphs of nx, probably the last grafs of the interrupted text sent earlier, covering the sig of the other RTTY sta. After Warsaw went off the air, the 2nd sta was found to be "RPFN," Monsanto Navrad, Portugal, w RYRY & foxes, 75 baud, that ran until 1507 (Ed.).

22960: French Emb., Brasilia, Brazil, w 5L msgs 1728-1736, + 2000-2015, w a final s/off msg at 2037, all ARQ6-90/200 (Ed.).

22967: HBD20, MFA, Berne, Switzerland, w ATS nx in FF, ARQ at 1331; and nx in GG at 1741 (Ed.).

22975.5: HBD20, MFA, Berne, w a telex in GG to Brasilia, Brazil, ARQ at 1340, and ATS nx in FF at 1435 (Ed.).

22977.2: HBD20, MFA, Berne, w a telex in EE to Panama City and Dhaka, ARQ at 1318 (Ed.).

22984.5: CLP23, Embacuba, Lagos, Nigeria, w 5F msgs marked "ordinario." Was 50 baud, 1733-1750 (Ed.).

23841.5: "RFFA," Min. of Def., Paris, France, w unclassified tfc, ARQ-E3/192 at 1654 (Ed.).

23305.5: RFQP, French Navy, Djibouti, w "controle de voie" at 1417, ARQ-M2/200 (Ed.).

23355: Italian Embassy, Damascus, Syria, w 5L msgs & a telex in II, 1437-1500, ARQ-E/96(Ed.).

23692: ZPK, Chaco Navrad, Paraguay, w RYRY, SGSG, & 10 count to HDN, foll by unclassified tfc in SS, 75 baud at 1615. S/off 1621 w 73 + AR (Ed.).

23854: "RFGW," MFA, Paris, France, w telexes in FF & 5L msgs to the French Embassy at Managua, Nicaragua, FEC-A/144 at 1630 (Ed.).

23921.5: "RFFA," Defense Ministry, Paris, w 5L msgs and unclassified tfc to Dakar, Senegal, ARQ-E3/192 at 1620 (Ed.).

24061.7: Egyptian Embassy, Dakar, Senegal, w telexes in AA, ARQ, 1428-1444 (Ed.).

24135: Un-ID idling in ARQ, 1602-1605, then sends QRXX selcal (Ed.).

24498.3: Un-ID army w "sinclas" (unclassified) tfc in SS, 50 baud, 1501-1530. Went to USB fon on 24497 briefly at 1503, for comms btwn 2 OM in SS (Ed.).

24790: ISX24, ANSA, Rome, Italy, w nx in FF, 50 baud at 1417 (Ed.).

24856-24858: MKD, RAF, Akrotiri, Cyprus, w RYI's, foxes & 10 count, FDM 50 baud on sev. channels at 1543 (Ed.).

24863.5: CLP25, Cuban Embassy, Maputo, Mozambique, w plaintext tfc & crypto after ZZZZZ, 75 baud

at 1423 (Ed.).

24871.5: "RFHJ," French Navy, Papeete, Tahiti, w "controle de voie," ARQ-E3/96 at 1802 (Ed.).

24990: Un-ID w a msg in Ee, ARQ at 1546 (Ed.).

25012.5: GYA, Royal Navy, London, England, w a test tape at 1624, 75 baud (Ed.).

25437: OXZ, Lyngby R., Denmark, w ARQ phasing sig & CW ID at 1612 (Ed.).

26158: UJY, Kaliningrad R., USSR, w telegrams to ships (QSX 25096.5) at 1319, 50 baud (Ed.).

27497.5: Un-ID in Columbia, SC, w "tnx very much for nice QSO 73 . . ." Was 45 baud at 1615. Was foll by KIT5PP, another un-ID sta, w RYRY, 45 baud at 1621 (Ed.).

ALPHA DELTA antennas, provide world-class reception solutions for our world-wide, customers—and here are some of their comments

Murray Ferguson
Owairaka
Auckland
New Zealand

November 10, 1990

Dear Sir,

This is just a short letter, to let you know how pleased I am with my new Alpha Delta (DX-SLOPER 60ft) which I have just received; I bought the antenna from Gilfer Shortwave, 52 Park Avenue, Park Ridge, NJ 07656, USA. They were very helpful to me.

I have put the antenna up, according to the instructions, I was able to get to 20ft without any problems.

The receiver I have, is a JRC NRD-525, and the antenna I had was an active antenna, and the bands it covers are 49, 41, 31, 25, 19, 13 meters, but it does not even come close to the performance of the Alpha Delta Sloper; Frequencies that were very weak or barely readable, in the past, are now loud and clear, and have a very good signal strength, and also the down lead, takes away all of back ground hum, which has always been a problem in the past.

Very sincerely yours,

Murray Ferguson

L.A. Locklear
Gulfport, MS 39501

December 21, 1990

Dear Sirs,

I recently purchased a "DX-EE" antenna from Universal Radio after seeing an advertisement in Popular Communications.

As a long time SWL and DX enthusiast all I can say is WOW!

I've tried them all over the years—nothing I've tried compares to the DX-EE. I have the DX-EE running North and South with an NRD-525 and FRG-8800 with unreal results. Your antenna, the DX-EE is the quietest dipole I've ever used.

Kudos on the DX-EE! Sales should pick up on this one as I have praised it time and again to fellow SWL'ers.

Sincerely,

L.A. Locklear

Alpha Delta Model DX-SWL International Broadcast Band Sloper
(AM BDCST thru 13 mtrs-60 ft. long) \$69.95

Alpha Delta Model DX-EE General Coverage "Utility" Dipole
(5 thru 30 MHz-40 ft. long) \$89.95

At your Alpha Delta dealer or add \$5.00 for direct U.S. orders-exports quoted.



ALPHA DELTA COMMUNICATIONS, INC.

P.O. Box 51117, Phoenix, AZ 85076 • (602) 966-2200



CIRCLE 138 ON READER SERVICE CARD

TELEPHONES ENROUTE

BY TOM KNEITEL, K2AES

WHAT'S HAPPENING WITH CELLULAR, MARINE & MOBILE PHONES

Some questions from readers have accumulated that are asked often enough to warrant being answered here in the column.

For instance, readers continually ask for updates on the legal status of monitoring cellular calls and if the Electronic Communication Privacy Act of 1986 (ECPA) is in the process of being repealed. The basic answer is that the ECPA is still in effect. It isn't in the process of being repealed, so it's still a violation of the ECPA to monitor cellular communications in the USA.

According to *Air Times*, a news bulletin issued by Bell Atlantic Mobile Systems, cellular phone security was at issue in two cases decided not long ago by a federal appeals court. After being dismissed in lower court, the suits, including *Margiotti v. Bell Atlantic Corp.* were combined into a single appeal. The federal appeals court affirmed the dismissal.

The plaintiffs claimed that their cellular carrier companies (that is, cellular service suppliers) had intentionally divulged the content of their cellular conversations by transmitting them "over radio waves capable of interception by eavesdropping third parties."

In its written opinion, the appellate court said that federal law does not prohibit cellular as a form of transmission simply because it is subject to interception. *Air Times* noted here that, "While cellular calls are difficult to monitor, it is still possible to do so."

The report went on to observe, "However, the higher court recognized that an eavesdropper would have to act independently of the carrier to listen in on a cellular call. In this case, it is the eavesdropper who violates the Privacy Act, not the carrier."

Among the questions that regularly arrive here are those relating to cellular technology. For example, Joe Bagrowski, of Baltimore, MD was curious about how the cell sites are established. He asks if each cell contains all of the cellular phone frequencies, or just certain blocks or groups of frequencies.

First, keep in mind that in areas where cellular services exist, the usual situation is for there to be two competing service suppliers. One is categorized as the "wireline" company, and is the local telephone utility. The other is the so-called "non-wireline" company, and is an independent supplier that doesn't operate a landline telephone

service. So, within the more than 830 channels (paired cell/mobile frequencies), about half are reserved for use only by all wireline companies, with the other half used exclusively by all non-wireline companies.

Depending upon the size of the market area being serviced, and the number of cell sites used by a particular supplier, a small community will have a system where each and every authorized channel is not utilized. On the other hand, in a large city's system using a great number of cell sites, all available channels will be in use. Moreover, in a large system, the same channel groupings will be duplicated in several of the company's cell sites.

Some cellular systems can get by with only one cell site. That site might be established to operate on a certain block of more than 45 channels. Cellular channels are spaced at 30 kHz intervals. The channels used at any individual cell site are each separated by 210 kHz, which means at seven channel intervals. So, a particular hypothetical cell site might use 870.03, 870.24, 870.45, 870.66, and so on.

In a system with two cell sites, the second cell site would use the same number of



Motorists in New York can dial up the NY State Police to report suspected intoxicated drivers. Dial (STAR)-D-W-I, it's a free call. (Photo courtesy NYNEX.)



Pioneer Electronics (USA) Inc., just entered the cellular market for the first time. They offer three new cellulars (left to right) the PCM-500, the PCH-600, and the PCM-300.

channels, but they would be different frequencies, such as 870.06, 870.27, 870.48, etc.

This way, seven channel groups can be selected for use in any system. If more than seven sites are used, the groupings can be duplicated over and over again, so long as cells using the identical channel groups are geographically separated by one or more cell sites using other channel groupings.

Originally, a total of 666 channels were established for wireline and non-wireline cellular systems. This included some channels set aside for digital control purposes. Later, when larger metro areas complained that more channels were required, the band was expanded to a grand total of 832 channels, although the expanded channel systems are used in only a few major areas at this time.

Car phones sold since 1988 are designed for a full 832 channel operation, so they can be utilized in any roaming area. Phones older than that are undoubtedly capable of operation on a maximum of 666 channels, although most can be readily retrofitted by a qualified technician for 832 channel operation.

Another thing to keep in mind regarding channel usage is called "sectorization." In Philadelphia, Washington, Baltimore, and some other busy areas, sectorization allows service suppliers to directionally orient certain cell sites, thus substantially increasing channel flexibility without interference.

What's Happening

In Washington, DC a neighborhood patrol group praised for its work in leading local police to numerous drug arrests, just received a portable cellular phone donated by Bell Atlantic Mobile Systems.

The 50-member SST Patrol, operates nightly, with three and eight people (wearing distinctive fluorescent caps) on the lookout for drug transactions and suspicious behavior. The cellular will put the patrol in quick, reliable, contact with Washington Metro Police officials to report sightings. The police say that the efforts of the SST Patrol have "significantly improved the community and have led to a drop in overall crime."

The New York State Police, throughout the state, will now investigate reports of suspected drunk driving on state highways by drivers who call in via their cellars. The special cellular toll-free number to call is (STAR)-D-W-I, however the system is also programmed to work if (STAR)-D-U-I is called since that number is used for similar calls in other states and it might be used by out-of-state drivers. The NYSP requests that callers be ready to provide information regarding the name of the road, location on the road, direction of travel, plus as good a description as possible (make, model, color, plate number) of the vehicle suspected of being operated by a DWI driver. Upon receipt of such a call, the nearest available po-

New Code Free License!

HAM RADIO BEGINNER'S PACKAGE

Enjoy amateur radio privileges above 30 MHz including voice (FM and SSB), and digital (packet radio) modes without having to pass a code test! The FCC has dropped the code requirement for the Technician Class License. Besides local communication on repeaters, with the proper equipment you can communicate through satellites and even bounce signals off the moon. Sometimes there are band openings that provide communication for hundreds—even thousands of miles!

Getting in on all this fun is simple. Just study the material in ARRL's **Tune in the World with Ham Radio**, **The ARRL Technician Class License Manual**, and **The FCC Rule Book**. You'll be ready to pass the 55 question exam in no time—and there are exam sessions given by volunteer examiners every weekend all over the country.

Tune in the World (book only) covers the basics of the electronics and FCC regulations covered in the first part of the exam. **The Technician Class License Manual** emphasizes the more advanced material found on the second part of the exam. **The FCC Rule Book** has all of the amateur radio regulations and important interpretations of the rules.

If you want to expand your operations to the 80, 40, 15 or 10-meter bands, you can still take the 5 wpm code test. For study, use the code learning cassettes in the **Tune in the World (kit)**. This package can be used to study for the Novice Class exam which requires code, but has only the basic 25 question written exam.

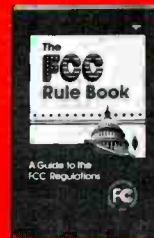
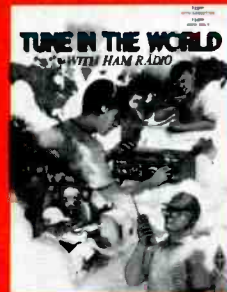

ORDER FORM

I would like to order the following:

- Tune in the World (book only) \$14.00
- Technician Class License Manual 6.00
- The FCC Rule Book 9.00
- Tune in the World (kit with code learning cassettes) 19.00

Please add \$4.50 for UPS shipping and handling

Enclosed is my check or money order for

\$ _____ or charge my: VISA

Discover MasterCard AMEX

Signature _____

Acct No _____

Good from _____ Expires _____

Name _____

Address _____

City _____ State _____ Zip/PC _____

PC



The American Radio Relay League

225 Main Street

Newington, CT 06111 USA

CIRCLE 5 ON READER SERVICE CARD

lice vehicle will be dispatched to the area. Officers will observe the car in question and, if necessary, stop and question its driver.

Among the typical characteristics that should make you suspect a driver might be intoxicated: going either far too slow or too fast, sudden lane changes, weaving or drifting from lane to lane, sudden use of brakes for no apparent reason, failure to use directional signals, driving without lights at night, excessive use of horn, and tailgating.

In addition to the regular U.S. Secret Service radio comms systems provided in connection with security for the President when he visits various cities, heavy use is also made of cellulars for security purposes. During a recent visit by the President to Mashpee, MA the brand new NYNEX cellular system on Cape Cod was suddenly busy with calls to and from the Secret Service, White House Advance Team, the White House Communications Agency, any by local, state, and municipal police.

Prior to the President's visit to any specific area outside Washington, DC, the WHCA

contacts the local telephone company's federal coordination group in the visiting region to assist in setting up the telephone network.

Hopscotching The World For Headlines

In St. John's, Antigua, the Caribbean cellular company Boatphone, is expanding its coverage to the islands of St. Maarten, Anguilla, St. Barts, Martinique, Guadelupe, and the U.S. Virgin Islands. Boatphone started out in 1986, and also provides service to the British Virgin Islands, St. Kitts and Nevis, Antigua and Barbuda, St. Lucia, St. Eustatius, St. Vincent, the Grenadines, and Grenada.

Much of Boatphones' service is with private charter yachts as well as fleets of the area's best bareboat companies. A sister company, CruisePhone, is installing cellular systems aboard some of the most popular Caribbean cruise ships. Boatphone's address is Lower Newgate Street, P.O. Box 1516, St. John's, Antigua, West Indies.

Motorola Inc.'s Radio-Telephone Systems Group has been awarded contracts to supply cellular systems in four of the eight cellular service regions of Mexico.

Motorola has also been selected as the supplier for the nationwide cellular network in Indonesia. This system serves 30,000 subscribers in Jakarta, Bandung, and Surabaya.

Millicom International Holdings Limited, a subsidiary of Millicom Incorporated, has been awarded a license to provide cellular service in Bolivia. The company already had similar licenses for Chile, Costa Rica, Guatemala, and portions of Mexico. The Bolivian system will operate mainly in major metro areas such as LaPaz, Cochamamba, and Santa Cruz.

Hardware Department

Pioneer Electronics, a leader in mobile electronics products, has just entered the cellular marketplace with a line of mobiles and handhelds.

Their PCM-500, PCM-300, and PCH-600 feature the latest technology, integrated into a new design featuring a unique titanium finish with amber illumination that complements modern vehicle interiors. The PCM-500 and PCM-300 are mobile units, the PCH-600 is the handheld.

The PCM-500 features 99-phone number memory storage of up to 24-digits each, also with alpha capabilities to permit storing names along with the phone numbers. The two-line LCD display allows for easy viewing of this information, and quickdialing offers fast access to stored numbers. A unique theft alarm automatically calls the owner at a pre-programmed number to warn when an unauthorized person starts the car ignition.

There is a dual NAM capability for registering the unit with more than one carrier, plus many other features in the top of the line cellular.

The PCM-300 is similar, but slightly less formidable. It offers a 40-number memory storage of up to 16-digits each, plus a number of other useful features.

The handheld PCH-600 has a memory for 99 phone numbers of 32-digits each, plus alpha for the names. You can scroll through the stored numbers. It has auto answer and auto redial. Dual NAM capability is only one of this unit's many features. Options include a vehicle installation kit with case, cigarette lighter adapter, and a quick charger. The standard battery offers more than two hours of talk time, or 30 hours standby. An optional high capacity battery offers double these times.

For more information, contact Pioneer Electronics (USA) Inc., 2265 East 220th Street, Long Beach, CA 90801, or circle 101 on our Readers' Service.

We hope that readers will write in with questions and comments relating to cellulars, pagers, IMTS phones, air/ground phones, ship/shore radio and similar. We also appreciate hearing from service suppliers as well as equipment manufacturers.

Clandestine Communique (from page 67)

21840. A recent QSL also lists this 1800-1900 broadcast but confirms reception of the usual 1600-1700 time. Incidentally, Radio Libertas now includes English segments in its broadcasts.

The station we suspected might be a new Nicaraguan clandestine turns out to be Colombian-related instead. George Zeller of Ohio has been watching this situation and has heard the station identifying as *Del Pueblo Responde*. It appears to be a right wing answer to left wing *Radio Patria Libre*, which opposes the Colombian government. Both stations can be heard during the 0030-0115 period (approximately) jumping around the area between 6285-6320. The "Pueblo" station may well have two assignments—jamming *Patria Libre* while airing programming to counter *Patria Libre*'s message. The Colombian guerrilla group ELN is behind *Patria Libre*, but, so far, there are no real clues as to the source and backers of Pueblo. It may well be the Colombian military or other department of the Colombian government. Some European circles were quick to point the usual finger at the CIA, but we think it's a little early for that.

Radio Iran, broadcasting to Iran via Egypt, was logged by Ross 9400 at 0222 in presumed Pashto. There were mentions of frequencies, and instrumental music on a high-pitched flute to 0225 when the program ended. An open carrier ran from 0225-0228, then there was a tone, interval signal and the station returned with announcements, marital music, talks and mentions of Iran.

Your contributions are more than welcome! We'd appreciate having news of stations logged, QSL's received, copies or actual literature from stations and their backers, news clippings and so on. We can keep your identity secure if you wish. ■

Scanning VHF / UHF (from page 36)

tralian station logged by skip here in the states. It is a power company on 39.25 MHz. He says that apparently VHF low band is used on a limited basis by utilities and military in Australia. Chuck would like Pete to write to him because he's interested in Australia's use of the 29.7 to 88 MHz range. Chuck also would be pleased to identify any skip stations Pete may have logged from the States or Canada. Chuck can be contacted through POP'COMM.

From Ashland, Kentucky, checks in Gene A. Bess, Registered Monitor, KKY4DB. Gene sent along an extensive listing of frequencies he compiled during a tour of duty at Fort Leonard Wood, Missouri. Here's a listing of Gene's frequencies from Fort Leonard Wood: 164.500, 93rd Evacuation Hospital F-1; 163.250, 93rd Evacuation Hospital F-2; 173.100, ambulance; 148.575, ammunition section; 150.450, ammunition section; 163.4625, cannon range; 165.0875, director of engineering and housing; 143.200, director of engineering and housing—furniture management; 49.75, explosive ordnance disposal; 49.70, explosive ordnance disposal; 49.80, explosive ordnance disposal; 173.9625, fire department; 173.4875, Forney Airfield; 124.100, Forney Army Airfield; 125.400, Forney Army Airfield; 172.750, hospital repeat paging administrators; 173.410, hospital; 143.415, mobile telephone; 163.5375, military police; 169.575, military police; 139.200, military police surveillance; 139.300, post guard; 148.025, range control; 36.45, range control; 173.7125, TMC units; 163.5625, transportation motor pool; 173.6125, transrail; 173.8125, fire department tac-1; 171.975, fire department tac-2; 164.9875, criminal investigation division; 165.0625, military police tac-1; 165.1875, military police tac-2. ■

COMMUNICATIONS SHOP

Advertising Rates: POP'COMM subscribers are entitled to one FREE 30-word, non-commercial classified ad per year. Enclose subscription name label with ad copy. For those people not in the previously mentioned group, non-commercial ads are 30 cents per word, including abbreviations and addresses; minimum charge \$6.00 per issue. Ads from firms offering commercial products or services are \$1.00 per word; minimum charge \$20.00 per issue. Boldface words are \$1.20 each (specify which words). Leading key words set in all caps at no additional charge. All ads must be prepaid in full at time of insertion; a 5% discount is offered for prepaid 6 time insertions. All ads must be typewritten double spaced.

Approval: All ad copy is subject to Publisher's approval and may be modified to eliminate references to equipment and practices which are either illegal or otherwise not within the spirit or coverage scope of the magazine.

Closing Date: The 10th day in the third month preceding date of publication. Because the advertisers and equipment contained in Communications Shop have not been investigated, the Publisher of Popular Communications cannot vouch for the merchandise listed therein. Direct all correspondence and ad copy to: PC Communications Shop, 76 N. Broadway, Hicksville, NY 11801.

SCANNER MODIFICATION INSTRUCTION MANUAL. Cellular modification instructions for the PRO2005, PRO2006, PRO34, BC760XLT, BC950XLT, BC200XLT & BC205XLT. Remote Control for PRO2005, PRO2006, BC760XLT & BC950XLT. Transportable power ideas. Increase PRO2006 speed. Pictures, diagrams, list of over 1300 frequencies, more. Only \$10. Above individual cellular instructions (specify) \$3. Individual remote instructions \$3. Add 100 Channels to the BC100XLT \$5. BC200XLT with cellular \$249, BC760XLT with \$279. Catalog and copy of **EAVESDROPPING FOR FUN and PROFIT** \$3. CC, MO or COD (COD \$20 min.) to: RF PRODUCTS, PO Box 1084, Montgomery, Alabama 36101 (205) 244-2050.

ELECTRONIC EAVESDROPPING EQUIPMENT DESIGN, reviewed by **Popular Communications** and **Popular Electronics**, gives 58 schematics of Sheffield Electronics' surveillance devices. Circuits explained. Transmitters range from pens to one-mile VOX's including crystal, subcarrier, carrier current, infrared, automobile, mains powered cube tap and duplex types. Demodulators given. Eighteen telephone transmitters are leech and battery types including crystal and subcarrier. Counter-measures chapter. Much more. This 8 1/2 x 11 inch 110-page book is illustrated with photographs. Price: \$30.00 + \$4.00 S&H. First Class Mail US/Canada. Overseas Airmail S&H \$9.00. Money Order or Cashier's Check, immediate shipping. Personal checks, 21 days. Send to: WINSTON ARRINGTON, 7223 S. Stony Island Ave., Chicago, IL 60649.

ICOM IC-R1 Communications Receiver - Handheld portable scanner. Wideband frequency coverage: 100 kHz to 1300 MHz continuous coverage. Signal strength indicator. 100 memories. 10 banks of search frequencies. FM, Wide FM and AM modes. Selectable channel separation: 0.5, 5, 8, 9, 10, 12.5, 15, 20, 25, 30, 50 kHz. Clock and power on/off timers. Built-in NiCD battery. Many other features. Uses same accessories as other ICOM handhelds. Includes AC adapter/charger, antenna, carrying strap, and belt clip. Dimensions 1.9"W x 4"H x 1.4"D, weight 9.9 oz. New with warranty. \$495. (703) 222-7554.

PAN-COM INT'L CATALOG. Over 350 Kits, Plans, Books about Licensed/unlicensed AM/FM broadcasting, Ham/CB/SW/DX amplifiers, 1750M transmitters, Surveillance devices, Computers/Software, Science Projects, MORE. \$1.00 refundable. Box 130-P04, Paradise, CA 95967.

SWL SLOPER covers AM broadcast through 13 meter bands. 60" long, \$53.95ppd., Jr. SWL Sloper covers 90 through 13 meter bands, 40" long \$43.95ppd., VGE, Box 21305, S. Euclid, Ohio 44121.

DESCRAMBLERS: OAK M35B, \$39.95. Also Jerrold, Zenith, Scientific Atlanta, etc. Guaranteed. Cable Plus, 14417 Chase #481-K Panorama City, CA 91402. 1-800-822-9955.

NEW! 7th Edition: Top Secret Registry of Government Radio Frequencies, by Tom Kneitel. Grown to gigantic 240-pages! 1000's of new listings, frequencies, stations for all scanner owners, nationwide. Includes: FBI, DEA, Customs, Secret Service, FCC, Immigration, Border Patrol, U.S. Attorney, ATF, Treasury, Fed. Prisons, U.S. Marshal, CIA, Postal Service, NSA, NORAD, USAF, USN, Army, USMC, FAA, NASA, DOE, NRC, FEMA, Dept. Agriculture, National Parks, USCG, EPA, DOT, V.A., UHF aero (225 to 400 MHz) listings, bugs & surveillance freqs, agents' lingo, codes, many more agencies, lots more info! Expanded Canadian listings. Only \$19.95, plus \$2 postage to N. American addresses. NY State residents add \$1.50 sales tax. Order now from CRB Research Books, P.O. Box 56, Commack, NY 11725. Dealer Inquiries Invited.

BUY direct our top quality uninterrupted power system - at substantial savings. These extremely reliable products available in wide range of power rating to accommodate a variety of user needs. Write today for free catalog, features a broad range of our power conditioning products. Send us your name, address, plus \$1 for postage & handling to: ALPINE INDUSTRIES, 9126 Medill, Franklin Park, IL 60131.

NEW! AIR-SCAN 5TH EDITION by Tom Kneitel. Complete guide to aero comms. Now in gigantic 192-page large-size format containing 60,000 + listings, including 2-30 MHz HF, 118 to 174 MHz VHF, 406 to 512 MHz UHF, and 800 MHz listings. Covers civil, military, private, and unlisted landing areas, heliports, and seaplane bases. Control towers, ground, approach/departure, FSS, unicoms, multicomms, crop dusters, air-ambulances, federal ops, traffic 'copters, aviation business, airline enroute, airport security/fire, etc. throughout USA. All Canadian mil, civilian airports and seaplane bases listed, plus lots more, including how-to text on aero monitoring. Most comprehensive aero frequency guide ever compiled. Only \$14.95 + \$2 postage to USA/Canada/APO/FPO. NY State residents add \$1.13 sales tax. From: CRB Research Books, Inc., P.O. Box 56, Commack, NY 11725, or ask your favorite communications dealer.

SCANNER MODIFICATION HANDBOOK by Bill Cheek ("Doctor Rigormortis"). New 160-page book. More than 20 performance improvement modifications. Simple step-by-step instructions, many photos. Primarily PRO-2004 & PRO-2005, some for PRO-34, BC-200/205XLT, BC-750XLT, BC-750XLT. Restore blocked out bands, speed up scanning rate, disable "beep," increase number of channels, improve squelch action, add an S-meter, interface with shortwave receivers, etc. Make the PRO-2004 & 2005 into a 6,400 channel scanner; put 3,200 channels into the PRO-34! Plus, cellular frequency charts, antenna info & mods, inside info on frequency management, operating hints, emergency power supplies, scanners & the law, lots more! Just issued, latest info. Only \$17.95, plus \$2 postage to addresses in USA/Canada. Residents of NY State add \$1.35 tax. CRB Research Books, P.O. Box 56, Commack, NY 11725.

COMMODORE 64 HAM PROGRAMS - 8 disk sides over 200 Ham programs - \$16.95. 25¢ stamp gets unusual software catalog of Utilities, Games, Adult and British Disks. Home-Spun Software, Box 1064-PC, Estero, FL 33928.

MTC-101 Microphone Test Center - repair and test any CB microphone only \$64.95 S/H included - send to **LORD/WYATT COMMUNICATIONS**, 30 East 54 Street, Brooklyn, NY 11203. (718) 493-3778 7 PM-10 PM EST \$15.00.

RIBBONINKER. Simple tool allows anyone to re-link computer ribbons for pennies. \$29 + \$4 shipping. For more information: Jack Schmidling Productions, Dept P, 4501 Moody, Chicago, IL 60630.

FOR SALE. Sony PRO-80, Regency HX2200 with cellular Sangean small digital portable. Will sell separately. Best offer. J.R. Drake, (416) 699-8052.

TRAVEL! HIGH INCOME! Radio Officers needed for ship-board employment. Must have FCC Second Class Radio-Telegraph license and background in electronics. Salary approximately \$4,000 monthly to start including vacation plus full benefits. Rae Echols, W7FFF, American Radio Association, 5700 Hammonds Ferry Road, Linthicum Heights, MD 21090.

SURVEILLANCE - Audio/Video/Infra-red/Laser. Law Enforcement, Industrial, Private. 500 Item Catalog \$7.00. Security Systems, 3017E Hudson, New Orleans, Louisiana 70131.

GILFER - first in Shortwave

New PHILIPS World Band Car Stereo Radio



At last, a world class, world band car radio that's worthy of the name. Tune in broadcast stereo FM, AM, and Shortwave from 3200 to 21850 kHz or listen to your favorite stereo cassette tape. It's all on the new Philips DC777. Digital readouts of band and frequency, 12 button keypad, 20 programmable memories for push-button tuning, mute search in 5 kHz steps, fine tuning in 1 kHz increments, clock/timer, autoreverse, stop, and play deck, audio control for balance, treble and bass, two 25 watt low distortion amplifiers, security code, quick-out chassis.

"Best Portable Of The Year" World Radio TV Handbook.

VISIT GILFER'S STORE

Easy to find, accessible

from New York City.

Take Garden State Park-

way (NE portion of N.J.),

Exit 172. Gilfer is in the

center of Park Ridge,

opposite the Borough

Hall. Store hours:

M-F 10am-5pm,

Sat. 10am-3pm.



Order operators: 1-800-GILFER-1
(1-800-445-3371) NJ 201/391-7887

GILFER SHORTWAVE
52 Park Ave. • Park Ridge, NJ 07656

CIRCLE 23 ON READER SERVICE CARD

HotWire The Low-Noise Long Wire for World Band Receivers

Ten times the capture area of a whip antenna
Ready to Use Installs Quickly Indoors or Out

Fully Insulated Weather Sealed Never Corrodes

HotWire improves reception without overloading your receiver. \$39.95

Its 45 ft antenna section snags weak signals while its 15 ft

shielded feedline cuts noise from computers and appliances.

Hang horizontal, vertical, sloping, or bent. Indoors or outdoors. \$3 S&H

portable or fixed. Infopak \$1.00

Order **AntennasWest**

1-800-926-7373 Hot-Line Box 50062 Provo UT 84605

CIRCLE 5 ON READER SERVICE CARD

CABLE TV CONVERTERS

Why Pay A High Monthly Fee? Save \$100's A Year

• All Jerrold, Oak, Ham-

lin, Zenith, Scientific

Atlanta, and more.

• Visa/MC and C.O.D.

• 60 Day Money Back

Guarantee

• Shipment within

24 hours

WE WILL BEAT ANYONE'S PRICE

No Illinois Orders Accepted

Electronic Engineering

P.O. Box 337, Barrington, IL 60011

Free catalog 1-800-542-9425 Information 1-708-540-1106

FREE SAMPLE COPY!

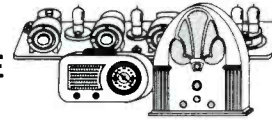

ANTIQUE RADIO CLASSIFIED

Antique Radio's Largest-Circulation Monthly Magazine

Articles - Classifieds - Ads for Parts & Services

Also: Early TV, Ham Equip., Books, Telegraph, 40's & 50's Radios & more...

Free 20-word ad each month. Don't miss out!

Free Sample. 6-Month Trial - \$13.

1-Year: \$24 (\$36 by 1st Class). Foreign - Write. A.R.C., P.O. Box 802-T6, Carlisle, MA 01741

CIRCLE 33 ON READER SERVICE CARD

SHORTWAVE RECEIVERS. HAM RADIOS. ANTENNAS, SCANNERS. Business Radios. ICOM, YAesu, KENWOOD, SONY, MOTOROLA.
 ... our 40th Year ... Worldwide shipping.
 Sales ... Service. Large Showroom. Open 7 days.

Barry Electronics Corp.
 WORLD WIDE AMATEUR RADIO SINCE 1950
 Your one source for all Radio Equipment!

212-925-7000 or Fax 212-925-7001
 512 Broadway, NYC, NY 10012

CIRCLE 22 ON READER SERVICE CARD

DISTINCTIVE RING SWITCH

Add additional phone numbers to a single line with the new Distinctive Ringing service from the phone company. RingDirector detects ring patterns and routes calls to phones, answering machines, FAX's or modems. 2-port \$89. 4-port \$149. S/H \$5.
 1-800-677-7969 FAX 516-676-9225

EXCELLENT TECHNOLOGY
 69 Smith Street, Glen Head, NY 11545

G5RV All-Band QuickKits
 created by Antennas West

- Fast & Easy to Build
 - Fail-Safe visual instructions
 - No measuring or cutting
 - Everything included
 - Finish antenna in minutes
 - Quality Components
 - Presoldered Silver Fittings
 - Kinkproof QuietFlex wire
 - Fully insulated, wax sealed, no-corrode, low noise design
 - Tune All Bands incl WARC
 - Build your own from scratch. Order Tech Note #124-C \$5.95 ppd USA
 - Call 801-373-8425 for Tech advice
- | | |
|--|---------|
| • Double Size G5RV 204 ft 160-10 Dipole | \$59.95 |
| • Full Size G5RV 102 ft 80-10 Dipole | \$35.95 |
| • Half Size G5RV 51 ft 40-10 Dipole | \$25.95 |
| • Quarter Size G5RV 26 ft 20-10 Dipole | \$19.95 |
| • Marconi Adapter kit converts any dipole to Marconi | \$ 7.95 |
| • 200' Diacon 250# line | \$11.95 |
- Order Hot-Line: 1-800-926-7373

CIRCLE 5 ON READER SERVICE CARD

CB RADIO OWNERS!

We specialize in a wide variety of technical information, parts and services for CB radios. 10-Meter and FM conversion kits, repair books, plans, high-performance accessories. Thousands of satisfied customers since 1976! Catalog \$2.

CBC INTERNATIONAL
 P.O. BOX 31500PC, PHOENIX, AZ 85046

PIRATE RADIO ON VIDEO

Inside Pirate Radio, a video documentary, looks into the free radio movement. Talks to those involved about tuning in, logging, QSL's, avoiding the FCC if you broadcast, and much more.

Inside Pirate Radio retails for \$19.95 (VHS) including S/H. We offer a money back guarantee and accept VISA, MC, Checks and UPS C.O.D. **\$19.95**

THE FRANKLIN VIDEO GROUP
 875 NORTH YOUNG STREET • FRANKLIN, IN 46131
 1-800-255-5659

Inside Pirate Radio running time: approx. 60 minutes

1-800-666-0908

Shortwave Radios—New 1991 Models

From: **SONY**

Sangean • Grundig • ICOM • Yaesu • JRC
 Scanners From Uniden Bearcat and AOR
 Low Discount Prices—Full Line Of
 Accessories

Lentini Communications, Inc.

21 Garfield St., Newington, CT 06111

Orders And Pricing Only: 1-800-666-0908

Tech Help And Info: 203-666-6227



CIRCLE 21 ON READER SERVICE CARD

ONTARIO SCANNER FREQUENCY DIRECTORY. New 430 Page directory! 11,600 large easy to ready listings. Most accurate, up-to-date information available. An invaluable reference book. Only \$21.00 plus \$3 postage. (Ontario residents add \$1.92 tax). Canscan, PO Box 3009, Tecumseh PS, Windsor, Ontario N8N 2M3.

NEW ENGLAND SCANNER OWNERS. Write for a catalogue of the complete series of **OFFICIAL Scanner Guides** for the New England States. Send stamped, self-addressed envelope to receive our current catalogue. **OFFICIAL Scanner Guide**, Post Office Box 712, Londonderry, NH 03053.

AR-1000 w/cellular \$455, **AR-2500** \$479, **AR-3000** \$895, **BC-200XLT** w/cellular \$259, **BC-800XLT** w/cellular \$259, **R-1600** with cellular \$289, Antennas, books, shortwave, CBs, accessories, much more!! 1991 catalog with huge used gear list \$125. And we take trades and ship COD. Galaxy, Box-1202, Akron, Ohio 44309 (216) 376-2402

SCRAMBLING NEWS monthly has a report this month on the new breed of "plain vanilla" satellite decoders which can be programmed to emulate VC, VC II plus, B-MAC, and Orion. They do work. \$19.95/yr. **PAY TV AND SATELLITE DESCRAMBLING 1991 EDITION** has the very latest turn-ons, bypasses, build-your-own circuits for cable, wireless and satellite. \$14.95. **NEW CATALOG \$1. SCRAMBLING NEWS, 1552 HERTEL AVE., BUFFALO, NY 14216. COD's ARE OK (716) 874-2088.**

WANTED: Collins 51S1 in excellent condition. Write stating price/condition or needs if willing to trade for collectable tubed audio components. Consider Drake R7A. Jim Widgren, 25 Marbeth Circle, Miller Place, New York, 11764.

WANTED: Pre-1970 lists of US radio stations, especially 1945-1960. White's Radio Log, Broadcasting Yearbook, etc. Will also purchase photocopies of same. Ralph Marson, 8070 Busch, Centerline, MI 48015.

INTERESTED IN TOURING ROMANIA, meeting hams and teaching newcomers the basics? Send letter with interests and relevant experience to: NEW ROMANIA COMMUNICATIONS, PO Box 192102, San Francisco, CA 94119-2102.

BEARCAT 300 excellent condition includes owners and shop manuals - \$185. Will ship UPS. Eddie Muro, PO Box 308, Cedarhurst, NY 11516, (506) 791-7630.

MAKE BIG \$\$\$! Become an American Electronics Dealer! Great profit opportunities for new businesses since 1965. Call Todd Parker. 1-800-872-1373.

TOMCAT'S BIG CB HANDBOOK, by Tom Kneitel. Just published, 221 large pages, fully illustrated. Complete guide to worldwide AM, SSB, Freeband, 27 MHz operations. Everything they never told you (legal & otherwise) from world's leading CB authority. Only \$13.95 (plus \$2 postage to North America) from CRB Research Books, Inc., P.O. Box 56, Commack, NY 11725. (NYS residents add sales tax). Dealer inquiries invited.

SCANNER FREQUENCY SEARCH SERVICE. Hear all there is to hear! SASE to: Heald, 6886P Jefferson Street, North Branch, MI 48461.

TUNE In On Telephone Calls. Tom Kneitel's new 160-page book. Everything you need to know to effectively use a scanner and communications receiver to eavesdrop on private telephone calls from homes, offices, cars, ships, aircraft, trains. Explanatory text, photos, extensive listings section covers USA/Canada on HF, VHF, UHF, and above; thousands of locations, frequency assignments. Explains equipment, best techniques, laws regarding monitoring cellular, cordless, ship/shore, high seas, Air Force 1, airliners, 1-way paging, more. Only \$12.95 (plus \$2 postage to USA/Canada/APO/FPO) from CRB Research, Box 56, Commack, NY 11725. NY residents add sales tax. Dealer inquiries invited.

WOW! UNDERSTANDING & REPAIRING CB RADIOS by Lou Franklin. Giant 380-page technical book picks up where **THE "SCREWDRIVER EXPERTS" GUIDE** leaves off. Includes circuit descriptions and troubleshooting guide for virtually all CB radios: 23 and 40-channel, crystal and PLL, solid-state and tube, AM, FM, SSB, CW, American, British and export models. Covers test equipment, transistor basics, synthesizers, receivers, transmitters, power supplies, T/R switching, antennas, interference, parts and accessory sources. Over 350 illustrations plus huge subject index. Moneyback Guarantee! Only \$29.95 plus \$3.50 U.S. & Canadian Air Mail, VISA/MC accepted. Free catalog of unique CB books, plans, and modification kits with order. Catalog only, \$2. **CBC INTERNATIONAL INC., BOX 31500PC, Phoenix, AZ 85046.** Thousands of satisfied customers since 1976.

RADIO MONITORS NEWSLETTER OF MARYLAND FOR THE SERIOUS SHORTWAVE AND SCANNER LISTENERS. PO Box 394, Hampstead, MD 21074. For a one year subscription: \$15.00. Sample copy: one dollar.

CORRESPOND or exchange information and ideas on cassette with a ham in New England area about Ham, SWL, Utility Monitoring, Scanning and related things. KB5JBS, HCR-9, Box 28C, Mena, AR 71953.

Order Form

Please print in block letters.

POPULAR COMMUNICATIONS

76 North Broadway, Hicksville, NY 11801

Name _____

Street _____

City _____

State _____ Zip _____

1	2	3	4	5
6	7	8	9	10
11	12	13	14	15
16	17	18	19	20
21	22	23	24	25

MOTOROLA TWO WAY RADIOS. Radios Mobiles and Portables from \$197.00, Three Year Warranty, Synthesized Models Available, MC/VISA, DATACOM 1-800-654-3660 EST.

FCC GENERAL RADIOTELEPHONE LICENSE CORRESPONDENCE COURSE. Also: Digital Electronics; BASIC Language; Computers; Electronics; Engineering; Drafting. Most courses just \$39.50! Satisfaction guaranteed. Free information. American Technical Institute, 730 S. Pleasantburg Dr., Suite 486, Greenville, SC 29607.

Radio Newyork International! Listen for us every Sunday night at 9 pm (Eastern), 8 pm (Central), 6 pm (Pacific) over WWCR, 7520kHz. All of your favorites: Al Weiner, Randi Steele, Dan Lewis, Pirate Joe, John P. Lightning, & more! Live call-in at 1-(800)-736-9764. QSL's (send SASE) from RNI, PO Box 270, Flushing, NY 11352. Spend your Sunday nights with RNI!

THE NEW YORK MONITOR NEWSLETTER—a monthly Newsletter that provides CB'ers with the latest up-to-the-minute Technical information—Radio Repair and Modification—Phase Lock Loop (PLL) Circuit/Expander—**2 YEAR COURSE IN ELECTRONIC COMMUNICATION** and much much more!! \$24 per year mail to **LORD/WYATT COMMUNICATIONS, P.O. Box 030128PCD, Brooklyn, NY 11203-0001.**

CW? NO PROBLEM. You can increase your speed, no matter how many times you've failed before. **Results guaranteed** when you follow the instructions. PASS Publishing's **CW Mental-Block Buster** program helps you **explode mental blocks** that hold you back. Based on 40 years of research, the **CW Mental-Block Buster** uses guided meditation, dynamic visualizations, and powerful affirmations to blast through mental blocks. **You can do code!** That means new bands, more contacts, more fun! (This is not a CW practice tape.) The **CW Mental-Block Buster** audio cassette and practice booklet are only \$24.95 ppd. In the US (NY residents add \$1.87 sales tax). (Quantity discounts available for classes.) PASS Publishing, P.O. Box 570, Stony Brook, NY 11780.

MORSE code got you down? Why let a mental block stand between you and upgrading? Use PASS Publishing's **CW Mental-Block Buster** to **blast through those barriers.** Just follow the instructions for 30 days—**Results Guaranteed!** Based on 40 years of research, the **CW Mental-Block Buster** uses guided meditation, dynamic visualizations, and powerful affirmations to blast through mental blocks. **You can do code!** That means new bands, more contacts, more fun! (This is not a CW practice tape.) The **CW Mental-Block Buster** audio cassette and practice booklet are only \$24.95 ppd. In the US (NY residents add \$1.87 sales tax). (Quantity discounts available for classes.) PASS Publishing, P.O. Box 570, Stony Brook, NY 11780.

SURVEILLANCE-COUNTERMEASURES! Transmitters, detectors, phone security, night vision, stunguns, secret devices, restricted books, **MORE! GUARANTEED LOWEST PRICES!** **HUGE CATALOG \$5.00 (REFUNDABLE)** Protector, P.O. Box 520294-D, Salt Lake City, UT 84152.

CW Lite is the **easiest** Morse code training method in the world, bar none! And it is the **fastest**, too. Just close your eyes and relax. This powerful **hypnosis cassette tape** does the rest. **Subliminals** speed you along! Only \$14.95 ppd in US (NY residents add \$1.12 tax). Order today! **PASS Publishing**, Box 570, Stony Brook, NY 11790.

FOR Sale: SGC SG-715 Portable HF Manpack with all accessories plus MBO, NDH-95 Scanner/Timer (For NRD 92/93 receiver) - MBO, Universal M-7000 with options, New - \$950.00. 2 ACE AR33 FM handheld receivers and accessories - \$150.00 each. MX-5000 scanner, New - \$325.00, MX-5000, used - \$175.00. Daiwa CNA 2002 2.5KW Auto tuner-MBO, MFJ-989 3KW Manual tuner-MBO, Horizon LTD Marine Base station, New - \$250.00. Yaesu FT103R with accessories - MBO, Kenwood TH-21AT with accessories - MBO. Will ship UPS COD (pre-paid) only. Call John, (305) 253-1299. 5:30-7:00pm EST.

MONITORING THE CALIFORNIA HIGHWAY PATROL. Much more than frequency listings! Nine chapters include beats, coverage, communications, even expanded 10-codes. 1991 edition only \$8.95. Taibo - 448 Ignacio #172 - Novato, CA 94949.

IRAQI RADIO LICENSE! CB, Ham, Broadcasting, etc! Outrageous, colorful, hilarious! Big 5 x 8 size! Gives you the right to invade all bands, annex them, hold them hostage, then run any power, try any mode, and use the best equipment you can steal! Not only suitable for framing, but 2 are sent absolutely FREE upon request and a #10 SASE. CRB Research Books, inc., PO Box 56-X, Commack, NY 11725.

225-400 MC RECEIVERS Tunable, Government Reconditioned. Satcom Antennas 240-270 MC Military Helical Type. New (419) 726-2249.

801-SCAN - ULTIMATE SCANNING SYSTEM for DOS PCs! 801-SCAN for ICOM R7000 or R9000 transforms your receiver! Version 3 now includes full event logging. Upgrade to serious software! IBM/clone w/640K required. Program from \$94.95, interfaces from \$59.95. Demo program \$2.55. Specify receiver. Check or M.O. only. Free information. 801-SCAN, 397 Dal-Rich Village #212, Richardson, TX 75080.

COMMUNICATION AT ITS BEST. Low prices on Scanners, CBs, Radar Detectors, Phones, Ans. Machines and Accessories. AR-900 234, HR2510 249, (XL 133, 19 plus 69) **FREE SHIP-PIPING V/MC.** **Turbo Electronics**, P.O. Box 8034, Hicksville, NY 11802. Questions Welcomed. (516) 938-1946.

SECRET NEW INVENTION STOPS EAVESDROPPERS! Easy to build. Stops extensions and most autostarts. Plans \$20.00. Parts \$10.00. \$3.00 S&H. **FREE** gift with order. Spy-Tex, PO Box 1258PC1, Austin, Texas, 78718-1258.

FREE ICOM, YAESU, KENWOOD TRANSCEIVER MODIFICATIONS! SCANNER MODIFICATIONS AND KEYBOARD TRICKS ALSO! **NO PARTS TO BUY!** (207) 674-3556 FOR TRACKED INFORMATION.

OFFICIAL AERONAUTICAL Frequency Directory. A 416 page directory covering high frequencies, very high frequencies, UHF 225-400 MHz military, 450-470 MHz and 800-950 MHz frequencies. Frequencies are listed by Community, Service, License, Frequency, Call Sign, and Comments. Included is General System Information, Federal Communication Commission Frequency Allocation Charts, and information on the new Aeronautical Radio Repeater System at most major airports. Also included are the Air Carrier Company Designators. Send \$21.95 plus \$2.05 shipping and handling to Official Scanner Guide, Post Office Box 712, Londonderry, NH 03053.

BAND ALLOCATION PROGRAM: For IBM compatible computers. Covers from 28 to 512 MHz, will look up by service or by frequency, also has 10-code decoder at a touch of a button. Only \$29.95, send check or money order to M. Meadows, 1917 E. Market St., New Albany, IN 47150.

THERE'S MORE TO DX THAN SHORTWAVE! TV-FM is hot now and mediumwave AM always abounds with DX. Veteran DX'er John Zondlo shows you how to get the most from these DX-packed bands in Discover DX'ing, the ultimate intro to TV-FM-AM DX'ing. Send \$5, Discover DX'ing, Box 770228, OKC, OK 73177.

RADIO SHACK PRO-2006 - \$369.95. Add \$7.50 S/H. Send certified check or M/O to: Bowers Communications, Box 62, Aberdeen, MD 21001-0062. Brand new units! Complete factory warranty!

TOUCH-TONE DECODER. Decode, store, and display touch-tone (DTMF) digits directly from your scanner, tape recorder, telephone line, or virtually any audio source. Decode dialed numbers received on **cordless, cellular!** PC board now available! Information for SASE. HB Technologies, POB 2771-P, Spring Valley, CA 91979.

GET DAILY-UPDATED SHORTWAVE FREQUENCY LISTINGS WITH YOUR COMPUTER! Hundreds of reception reports are input and sorted to bring you up-to-the-minute information. Dial the DOWNLOAD AMERICA BBS. Free access. International messaging. Multi-line. 24 hours/day. Modem number (203) 676-1708.

Advertiser's Index

AMC Sales, Inc.	70
ARRL	75
Ace Communications, IN	80, Cov. III
Alpha Delta Communications	73
Amateur Electronic Supply	6
Antenna Supermarket	45
Antennas West	72, 77, 78
Antique Radio Classified	77
Ashton ITC	44
Associated Radio	31
Barry Electronics	78
CBC International	78
CRB Research	34, 72
Cellular Security Group	70
Communications Electronics	33
DECO	61
Datametrics	65
Delta Research	61
Electron Processing	11
Electronic Engineering	77
Electronic Equipment Bank	1
Excellent Technology	78
Franklin Video Group, The	78
GRE America, Inc.	35
Gilfer Shortwave	77
Hamtronics, Inc.	79
ICOM	39, Cov. II
Japan Radio Co., Ltd.	13
JoGunn Ent.	23
Kenwood U.S.A. Corp.	Cov. IV
Lentini Communications	78
MFJ Enterprises, Inc.	21
Moonbeam Press	72
OEI OPTOElectronics	5, 7
Pacific Cable Co.	72
POP'COMM Bookshop	37
React International	66
Republic Cable Products, Inc.	70
Scanner World, USA	8
Signal Engineering	47
Software Systems Consulting	20, 29
Somerset Electronics	52
Systems & Software	61
Universal SW Radio	3, 65

JRC NRD-525 HF Receiver

- Receive 90 kHz to 34 MHz V/UHF
- With Optional CMK-165 Converter
- 200 Memory Channels
- AM, FM, U/LSB, RTTY, FAX
- Multi Scan Feature



CALL TODAY!

ICOM

- #### IC-R9000 THE FINE ART OF LISTENING
- Continuous, All-Mode Receiver
 - Covers 100 kHz to 2 GHz
 - 1,000 Memories
 - Advanced CRT Display
 - Direct Digital Synthesizer System
- CALL FOR ALL DETAILS!



ICOM

- #### IC-R71A SUPERIOR PERFORMANCE RECEIVER
- USB, LSB, AM, RTTY and Optional FM
 - Covers 1 to 30 MHz
 - 32 Memory Channels
 - Multi Scanning Functions
 - Keyboard Frequency Entry
- CALL TODAY!



KENWOOD

- #### R-5000 HIGH PERFORMANCE RECEIVER
- Covers 100 kHz to 30 MHz
 - 100 Memories
 - Keyboard or Main Dial Station Selection
 - Programmable Scanning
- CALL TODAY FOR DETAILS!



Amateur and SWL Accessories



HAMTRONICS, INC.

M, T, W (9-6)
Th, F (9-8)
Sat (9-3)

4033 Brownsville Road, Trevose, PA 19047
For Service & Info (215) 357-1400 For Orders (800) 426-2820 FAX 215-355-8958

CIRCLE 134 ON READER SERVICE CARD

AOR Scanners.

Great Performance. Great Service. Great Value.

Free Freight
25-Day Money-Back Guarantee
Toll-Free Service and Support
No Credit Card Surcharge
One Year Warranty



AR1000 **\$399**

1000 Channels. 8-600MHz, 805-1300MHz

Standard Features:

- Extremely compact size.
- Continuous coverage (except UHF TV 600-805)
- Antenna attenuator switch, 10db.
- Manual tuning knob.
- Earphone jack, 3.5mm.
- AM, FM and wide band FM tuning modes.
- Backlighted LCD display.
- 10 Scan Banks, 10 Search Banks.
- Selectable Priority Channel.
- Delay, Hold Features.
- Selectable Search Increments, 5-955KHz.
- Permanent memory backup.
- 4 AA Ni Cad batteries included.
- AC adaptor/charger.
- Carry Case.
- Cigarette Lighter Charger.
- Belt Clip.
- Earphone.

Options:

- External Speaker. Mobile Mount. MS190 \$19.50
- Extended Warranty. 2/3 yrs \$45/\$55

Specifications:

- Coverage: 8-600, 805,1300MHz
- Sensitivity: .35uV NFM, 1.0uV WFM, 1.0AM
- Speed: 20 ch/sec. scan. 40 ch/sec. search
- IF: 561.225, 58.075, 455KHz or 10.7MHz
- Increments: 5 to 955KHz selectable/ 5 or 12.5 steps.
- Audio: .4 Watts
- Power: Input 9 - 13.8 V. DC
- Antenna: BNC
- Display: LCD
- Dimensions: 6 7/8H x 1 3/4D x 2 1/2W. 12oz wt.

AR950 **\$239**



100 Channels. Low, Air, High, UHF & 800MHz.

Standard Features:

- Extremely compact size.
- Unrestricted 800MHz coverage.
- 100 channels permanent memory.
- Earphone Jack & Attenuator.
- Delay, Hold features.
- Channel 1 Priority.
- 5 Scan Banks, 5 Search Banks.
- Telescopic and Flexible Antennas w/ BNC connector.
- AC & DC Power cords w/ mtng hardware.
- One Year Limited Warranty.

Options:

- Base type antenna
25 to 1000MHz w 50'coax. AS300 \$59.95
- Mag Mnt Mobile Antenna. 15' coax. MA100 \$25.00
- Cigarette Lighter power adaptor. CP100 \$4.00
- External Speaker
with mobile mount. MS100 \$19.50
- Extended Warranty. 2/3 yrs \$40/\$55

Specifications:

- Coverage: 27-54, 108-174, 406-512, 830-950MHz
- Sensitivity: .4uV Lo,Hi. .8uV Air. .5uV UHF. 1.0uV 800
- Scan Speed: 15 ch/sec.
- IF: 21.4MHz, 455KHz
- Increments: 10,12.5,25,30
- Audio: 1W
- Power: 12.8VDC, 200MA
- Antenna: BNC
- Display: LCD w/backlight
- Dimensions: 2 1/4H x 5 5/8W x 6 1/2D. 14oz wt.

We offer 100's of communications products.

AR3000

\$995



AR2500

\$499



2016 Channels. 1 MHz to 1500 MHz

Standard Features

- Continuous coverage
- AM, FM, wide band FM, & BFO for SSB, CW.
- 64 Scan Banks.
- 16 Search Banks.
- RS232 port built in.
- Includes AC/DC pwr crd. Antenna, Mntng Brckt.
- One Year Limited Warranty.

Options:

Earphone.	EP200	\$2.00
External Speaker. Mobile Mount.	MS190	\$19.50
Extended Warranty. 2/3 yrs.		\$65/75
Mobile Mounting Bracket.	MM1	\$14.90
RS232 Control Package	SCS2	\$295.00
(software & cable) offers spectrum display and database.		

Specifications:

Coverage:	1 MHz - 1500MHz
Sensitivity:	.35uV NFM, 1.0uV WFM, 1.0AM/SSB/CW
Speed:	38 ch/sec. scan. 38 ch/sec. search
IF:	750.00, 45.0275, 5.5MHz 455KHz
Increments:	5,12,5,25 KHz
Audio:	1.2 Watts at 4 ohms
Power:	Input 13.8 V. DC 300mA
Antenna:	BNC
Display:	LCD, backlighted.
Dimensions:	2 1/4H x 5 5/8W x 6 1/2D Wt. 1lb.

400 Channels. 100KHz to 2036MHz.

Standard Features:

- Extremely compact size.
- Continuous coverage
- Attenuation Programmable by Channel.
- Manual tuning knob.
- Tuning increments down to 50Hz.
- AM, FM, wide band FM, LSB, USB, CW modes.
- Backlighted LCD display.
- 4 Scan and Search Banks, Lockout in Search.
- 4 Priority Channels.
- RS232 control through DB25 connector.
- Delay, Hold Features.
- 15 band pass filters, GaAsFET RF amp.
- Sleep and Alarm Features.
- AC adaptor/charger. DC power cord.
- Telescopic Antenna.

Options:

Earphone.	EP200	\$2.00
External Speaker. Mobile Mount.	MS190	\$19.50
Extended Warranty. 2/3 yrs.		\$65/75
Mobile Mounting Bracket.	MM1	\$14.90
RS232 Control Package	SCS3	\$295.00
(software & cable) offers spectrum display and database.		

Specifications:

Coverage:	100KHz - 2036MHz
Sensitivity:	.35uV NFM, 1.0uV WFM, 1.0AM/SSB/CW
Speed:	20 ch/sec. scan. 20ch/sec. search
IF:	736.23, (352.23) (198.63) 45.0275, 455KHz
Increments:	50Hz and greater
Selectivity:	2.4KHz/-6db (SSB) 12KHz/-6db (NFM/AM)
Audio:	1.2 Watts at 4 ohms
Power:	Input 13.8 V. DC 500mA
Antenna:	BNC
Display:	LCD
Dimensions:	3 1/7H x 5 2/5W x 7 7/8D Wt. 2lb 10oz.

To Order Call 1•800•445•7717

In All 50 States and Canada. 24 Hours a Day. Fax Orders: 1-800-448-1084, 24 Hours a Day.

ACE Communications Monitor Division 10707 E. 106th Street, Fishers, IN 46038

Int'l Voice# 317-842-7115. Int'l Fax# 317-849-8794.

Service and Support Lines: Mon-Fri 9a.m. to 9p.m., Saturday 10-4. EST

MasterCard, Visa, American Express, Checks, Approved P.O.'s. & C.O.D. (add 5.00)

Prices and specifications subject to change.

KENWOOD

Hear it All!



R-5000 R-2000 High performance receivers

Scan the world bands with Kenwood's R-5000, R-2000 and RZ-1. Listen in on foreign music, news, and commentary. Monitor local police, fire, and other public safety services, as well as the Marine channels, and the many other services.

(The VHF converter options must be used in the R-5000 and R-2000.)

R-5000

The R-5000 is a high performance, top-of-the-line receiver, with 100 memory channels, and direct keyboard or main dial tuning—makes station selection



R-2000

The R-2000 is an all band, all mode receiver with 10 memory channels, and many deluxe features such as programmable scanning, dual 24-hour clocks with timer, all-mode squelch and no-se blankers, a large, front-mounted speaker, 110 volt AC or 12 volt DC operation (with the DCK-1 cable kit), and 118-174 MHz VHF capability with VC-10 option.

Optional Accessories R-2000:

- VC-10 VHF converter
- DCK-1 DC cable kit for 12 volt DC use.

R-5000:

- VC-20 VHF converter
- VS-1 Voice module
- DCK-2 for 12 volt DC operation
- YK-88A-1 AM filter
- YK-88SN SSB filter
- YK-88C CW filter
- MB-430 Mounting bracket.

Other Accessories:

- SP-430 External speaker
- SP-41 Compact mobile speaker
- SP-50B Mobile speaker
- HS-5 Deluxe headphones
- HS-6 Lightweight headphones

super easy! Other useful features include programmable scanning, large, built-in speaker, 110 volt AC or 12 volt DC operation (with optional DCK-2 cable), VHF capability (108-174 MHz) with the VC-20 option, dual 24-hour clocks with timer, and even voice frequency readout with the VS-1 option.

RZ-1

Wide-band scanning receiver



The RZ-1 wide-band, scanning receiver covers 500 kHz-905 MHz, in AM, and narrow or wideband FM. The automatic mode selection function makes listening

easier. One hundred memory channels with message and band marker, direct keyboard or VFO frequency entry, and versatile scanning functions, such as memory channel and band scan, with four types of scan stop. The RZ-1 is a 12 volt DC operated, compact unit, with built-in speaker, front-mounted phones jack, squelch for narrow FM, illuminated keys, and a "beeper" to confirm keyboard operation.

- Optional Accessory**
- PG-2N Extra DC cable

KENWOOD U.S.A. CORPORATION
COMMUNICATIONS & TEST EQUIPMENT GROUP
P.O. BOX 22745, 2201 E. Dominguez Street
Long Beach, CA 90801-5745
KENWOOD ELECTRONICS CANADA INC.
P.O. BOX 1075, 959 Gana Court
Mississauga, Ontario, Canada L4T 4C2

KENWOOD

...pacesetter in Amateur Radio

CIRCLE NO. 10 ON FREE INFORMATION CARD

Specifications, features, and prices are subject to change without notice or obligation.