

APRIL 14th, 1934

# RADIO

REG. U.S. PAT. OFF.

# WORLD

The First and Only National Radio Weekly  
629th Consecutive Issue Thirteenth Year

ULTRA-FREQUENCY  
OSCILLATORS

**15¢**  
Per Copy

PICTURE DIAGRAM  
OF 2-TUBE SET  
FOR SHORT WAVES



MULTI-RANGE  
DIAL SYSTEMS

## ALL-WAVE 11-TUBE SKY-RAIDER



A Super for Broadcasts, a Double Super for Short Waves. For Alan Mannion's Article on His Excellent Receiver, See Pages 12 and 13.



# LINE-BLOCKED UNIVERSAL TEST OSCILLATOR



THIS Test Oscillator, Model 30-NB, is serviceable for all intermediate frequencies from 135 k.c. up, and all broadcast frequencies, for lining up the receiver channels. It is constantly modulated and the same instrument works on 90-120 volts a.c. (any line frequency), line d.c. or batteries. A new improvement is line blocking, so the only feed to the receiver is through a wire from output post of Test Oscillator. Frequencies are direct-reading and never more than 1% off. Model 30-NB is contained in shield cabinet. Etched metal scale is non-warping. Oscillator sent free (complete with 30-tube, ready to operate) on receipt of \$12 for a 2-year subscription for Radio World (104 issues, one each week). Order Cat. 30-NB.

RADIO WORLD, 145 West 45th Street, New York, N. Y.

## SPEAKER REPAIRS

Free edge cone and voice coil assembly. Field coils for all Dynamic Speakers.



We take care of all your speaker troubles. THE MOST COMPLETE ORGANIZATION OF ITS KIND IN THE UNITED STATES

Cleartone Speaker Service

Fourth Floor  
72 Cortlandt Street New York City

## For information about the "SKY-RAIDER"

11-tube all-wave receiver

Write to

## MANNION LABORATORIES

135 Liberty St., New York City

This laboratory will gladly furnish estimates or designs on special receivers or other electronic equipment.

# You Can't Beat

this price

**\$6.50**

COMPLETE

## for a genuine Stromberg-Carlson Magnetic Pickup Outfit

IT isn't often that such an opportunity presents itself. Take advantage of this low price. We cannot guarantee that we will have these pickups long because they will go fast at this low price.

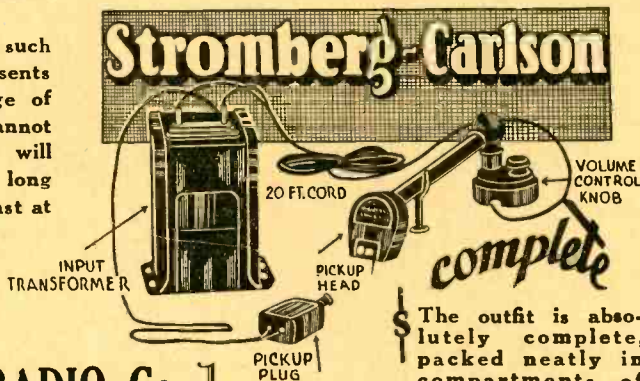

The outfit is absolutely complete, packed neatly in compartments of original Stromberg-Carlson box.

RELIABLE RADIO Co.

145 West 45th Street, New York City

## Selected Quality Tubes FREE With Subscriptions for Radio World

Here is your opportunity to subscribe for RADIO WORLD and get just the tube or tubes you want, made by a very large, reliable, licensed tube manufacturer; picked tubes you'll appreciate. On this offer you have five days after receipt to put the tube to any logical test, and if not entirely satisfied with its performance, return it for replacement.

For an 8-week subscription (8 issues, one each week), at the regular price, \$1.00, you may select any one of the following tubes as free premium, or more at the same rate (\$2, 16-weeks subscription for two tubes, etc.), from this particular list: 01A, 01AA, IV, 12Z3, 112A, 24A, 26, 27, 30, 31, 35, 36, 37, 38, 39, 45, 47, 51, 56, 71A, 80, 82.

With a 13-week subscription (13 issues), at the regular price, \$1.50, any one of the following tubes, or more at the same rate, from this particular list (two for a 26-week \$3.00 subscription, three for 39-week \$4.50 subscription, four for 52-weekly, yearly \$6.00 subscription, etc.), 1A6, 5Z3, 2A5, 2A6, 2A7, 2B7, 6A4, 6A7, 6B7, 6F7, 25Z5, 2Z, 32, 33, 34, 41, 42, 44, 46, 49, 53, 55, 57, 58, 59, 67, 75, 77, 78, 83, 83V, 84, (6Z4), 85, 89, 483, 485.

For a \$4.00 subscription, 34 weeks (34 issues), one No. 10 tube or one No. 50 tube may be obtained.

You may select any assortment of tubes desired and send in a subscription amount for the total required under the above classifications.

RADIO WORLD, 145 West 45th Street, New York, N. Y.

**UNIVERSAL Stretched-Protected Diaphragm Type 1934 Model "BB"**

Now with stretched diaphragm fully protected against damage. Superlative quality of reproduction makes Model "BB" the general all purpose microphone for both voice and music. No increase in price. Sold by Jobbers everywhere.  
Universal Microphone Co., Ltd.,  
Inglewood, Cal., U. S. A.

**HENLEY'S "TWENTIETH CENTURY BOOK OF RECIPES, FORMULAS & PROCESSES."** New 1933 Edition. Ten thousand processes, recipes, trade secrets and money-making formulas. For the laboratory, workshop, factory and home. Some subjects fully covered: Dyes, Inks, Waterproofing, Perfumes, Cement, Plating, Glass, Dentifrices, Varnishes, Soaps, Glues, Paints, Adhesives, Emamelling, Hairdressings, Cosmetics, Oils. Price, \$4.00. Book Dept., Radio World, 145 W. 45th St., New York City.

**RADIO WORLD AND RADIO NEWS.** Both for one year, \$7.00. Foreign, \$8.50. Radio World, 145 W. 45th St., N. Y. City.

## Matched Condenser and Coils for Dual-Band Tuning

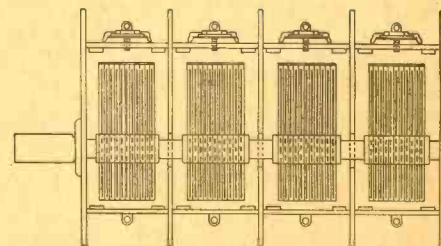

A four-gang tuning condenser of the semi-precision type. Small in size, exact in adjustment and construction for precise tuning. It ranges in capacity from 18 to 406 mmfd. Has built-in trimmers, 8 to 35 mmfd. With standard coils intended to be tuned with a 0.00035 to capacitance, this condenser will cover the band from 200 to 600 meters. The sections are separated by half shields, while a shield as high as the maximum height of the rotor plates is at each end. The rotors are turned by a common shaft, 3/16" in diameter which is mounted on ball bearings. Condenser closes to the left and is equipped with mounting shades. Overall size 5x3 1/4 x 2 1/2 inches (not including shaft for dial in measurement). Noted for its extreme compactness. 4-gang condenser Cat. No. 4GG @ \$2.95 Set of four shielded coils for this condenser, for 465 kc super, includes three r-f and oscillator coil. Tapped for police calls. DLC @ \$1.50

RELIABLE RADIO COMPANY

145 WEST 45th STREET NEW YORK CITY



# POWERTONE'S

## 6 STEPS TO WORLD-WIDE FAME

*All Coils in Each Set are the Famous BRUNO Make*



### 1 SCOUT One Tube All-Wave

Battery Operated  
S.W. Receiver

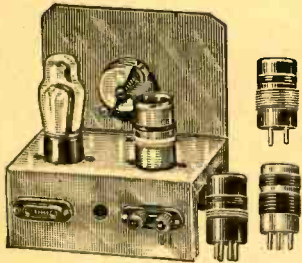

A set for the beginner! Will cover the entire short wave and broadcast bands. It is remarkable how the "Scout" intercepts short wave signals. Police signals, ship to shore, airplane, amateurs, etc., tuned with ease.

Parts in the kit are of the highest quality. Smooth regeneration control. Exceedingly simple to build. Uses

1-230 tube, 2-1½ volt dry cells, and 1-45 volt "B" battery.

- Model SC-1-K—Complete kit of parts..... **\$3.95**
- Model SC-1-W—Wired and tested..... Extra 1.00
- Sylvania 230 tube..... .70
- Set of batteries..... 1.60
- Set of Matched headphones..... .95
- Broadcast coil—200-550 meters..... .39

### 2 POWERTONE Wallace Hoover Cup Winner Short Wave Receiver

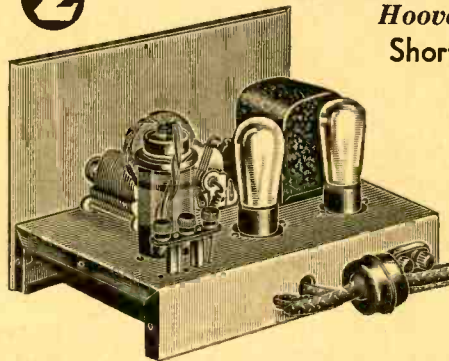

Designed by Don C. Wallace, featuring band spread tuning and coupler for Doublet Antenna. Probably the finest two-tube, battery operated short wave receiver ever designed.

Uses the economical two-volt 230 tubes. Easily converted to A.C. operation. Re-

- quires 2-1½ volt dry cells, and 45-135 volts "B".
- One silver-wound, octo-formed coil included in each kit. Choice of one of the following 20-32, 40-60, 75-150, 150-200 meter. **\$10.90**
- Model PW-2-K—Kit of parts..... Extra 2.00
- Model PW-2-W—Wired and tested..... Extra 2.00
- Model PW-2-T—Set of matched Sylvania tubes..... 1.40
- Model PW-2-C—Each coil, additional..... .95

### 3 POWERTONE Three Tube A.C. Short Wave Receiver



15-550 METER TUNING RANGE

One of the most popular of the Powertone line of short wave receivers. Tuner and pack all built in one. Uses 1-'56, 1-'58 and 1-'80 rectifier tubes.

Especially recommended for use with headphones. Covers both the short and broadcast band with the aid of plug-in coils. Rust-proof chassis is mounted into beautiful modernistic, crystal-finished cabinet.

- Model SW5009-K—Kit of parts **\$10.95**
- Model SW5009-W—Wired and tested. Extra, 2.00
- Set of matched Sylvania tubes..... 1.95
- Set of matched headphones..... .95
- Broadcast coil (200 to 550 meters)..... .39

### 4 REGENT Four Tube A.C. Short Wave Receiver With Built-in Speaker

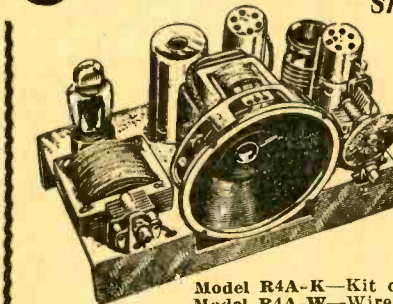

15 to 550 METERS  
Up-to-the-minute in short wave design. Dynamic speaker is built directly into the chassis, making the entire receiver one unit. Built-in power supply.

World-wide, loud speaker reception. Uses 2-'58's, 1-'80 and 1-2A5 tubes.

- Model R4A-K—Kit of parts..... **\$11.50**
- Model R4A-W—Wired and tested. Extra, 2.00
- Complete set of Sylvania matched tubes..... 2.50
- Modernistic cabinet..... 1.50
- Broadcast coil (200 to 550 meters)..... .89

### 5 POWERTONE De Luxe Short Wave Receiver



15 to 550 Meter Range

The latest addition to the famous line of Powertone short wave receivers. New type airplane dial. Built-in tuner and pack. Provisions for headphones. Low-loss, octo-formed coils. Uses 2-'58's, 1-'56, 1-'80 and 1-'50 tubes.

- Model SW5008-K—Kit of parts..... **\$24.50**
- Model SW5008-W—Wired and tested..... Extra, 5.00
- Set of matched Sylvania tubes..... 3.75
- Broadcast coil (200-550 meters)..... .89

### 6 POWERTONE 6 Tube All Wave Super-Het Short Wave Receiver

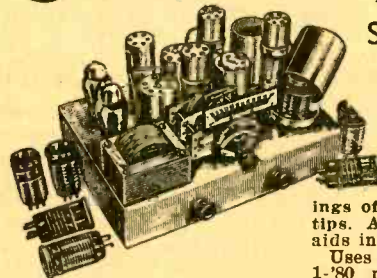

The most advanced model in the Powertone Short Wave Receiver line. Any experienced short wave fan can construct it with little effort. All the short wave offerings of the world are at your finger tips.

Automatic regeneration control aids in tuning-in the weaker stations. Uses 1-2A7, 2-'58's, 1-'55, 1-2A5 and 1-'80 rectifier tubes. Two sets of plug-in coils cover the short wave band. (14-200 meters.)

- Model PS-6-K—Kit of parts with 8 coils..... **\$24.50**
- Model PS-6-W—Wired and tested..... Extra, 5.00
- Set of matched Sylvania tubes..... 3.95
- 2 Broadcast coils (200 to 550 meters), each..... .89

FREE Servicemen's Manual with each Set. Regular 25c.

**TRY-MO RADIO CO. INC. 85 Cortlandt St. New York**

Headquarters for short wave and transmitting equipment.

Address All Mail to Dept. RW

SEND FOR NEW 1934 CATALOG—FREE



ROLAND BURKE HENNESSY  
Editor

HERMAN BERNARD  
Managing Editor

# RADIO WORLD

REG. U.S. PAT. OFF.

The First and Only National Radio Weekly  
THIRTEENTH YEAR

J. E. ANDERSON  
Technical Editor

J. MURRAY BARRON  
Advertising Manager

Vol. XXV

APRIL 14th, 1934

No. 5. Whole No. 629

Published Weekly by Hennessy Radio Publications Corporation, 145 West 45th Street, New York, N. Y.

Editorial and Executive Offices: 145 West 45th Street, New York

Telephone: BR-yant 9-0558

OFFICERS: Roland Burke Hennessy, *President and Treasurer.*  
M. B. Hennessy, *Vice-President.*  
Herman Bernard, *Secretary.*

Entered as second-class matter March, 1922, at the Post Office at New York, N. Y., under Act of March 3, 1879. Title registered in U. S. Patent Office. Printed in the United States of America. We do not assume any responsibility for unsolicited manuscripts, photographs, drawings, etc., although we are careful with them.

Price, 15c per Copy; \$6.00 per Year by mail. \$1.00 extra per year in foreign countries. Subscribers' change of address becomes effective two weeks after receipt of notice.

## Ultra-Frequency Oscillators Offer a Limitless Chance for Profitable Experimenting

By J. E. Anderson

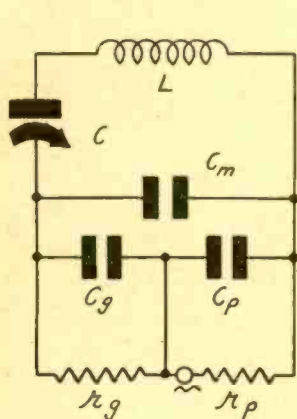

FIG. 1

The equivalent network of an ultraudion oscillator showing the three tube capacities,  $C_p$ ,  $C_g$ , and  $C_m$ , the grid condenser  $C$ , and the inductance  $L$ . This applies to ultra-high frequencies.

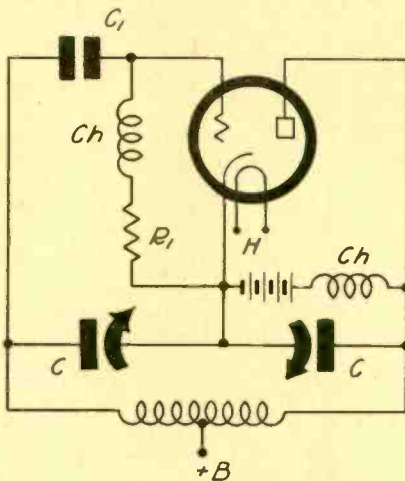

FIG. 2

The circuit of a short-wave oscillator often used. It is doubly periodic but is converted to a Colpitts by putting a radio-frequency choke in the B supply lead.

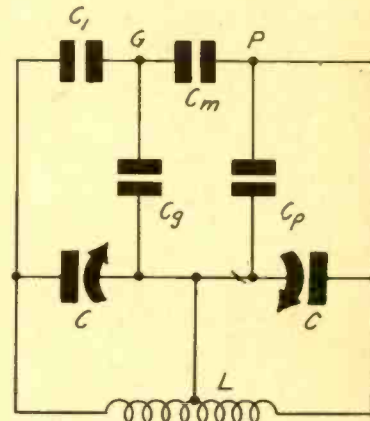

FIG. 3

The equivalent network of the circuit in Fig. 2 before the choke has been put in.  $C_1$  is the grid stopping condenser, which may be used for tuning if condensers  $C$  are omitted.

THE radio experimenter who has ceased to find much excitement in the reception of broadcast and short-wave stations but who still wishes to indulge in his hobby can get an endless amount of interest and pleasure out of the ultra-short waves, which he himself can generate and receive.

The advantage of working with ultra-short waves is that the apparatus costs practically nothing and no antennas of large dimensions are required. The generation and reception of ultra-short waves is a game which any one can play, and the main prize is the generation of the shortest wave. There is comparatively little trouble in getting down to 3 meters, but to get down below one meter is a harder nut to crack. Yet anybody who has a few radio apparatuses has as good chance as any one else getting down. The utilization of the ultra-short waves after they have been generated and detected is another problem, but that, too, is in the same game.

### Short-Wave Circuits

The problem of generating ultra-short waves is mainly one of reducing the distributed capacities, mainly those pertaining to the tube. Of course, the inductance can also be reduced, and must be if the generated waves are to be very short, but if the inductance is made too low, the circuit will not oscillate because it does not have enough fly-wheel effect. In an effort to reach the ultra-short

waves many experimenters have resorted to push-pull circuits, but little is gained in that direction, for as more tubes are added, capacities are also added.

As an aid in understanding what capacities enter into the problem and in what way they affect the frequency generated, let us look at Fig. 1. This represents the a-c portion of an oscillating circuit of the ultra-audion type. There is supposed to be a radio-frequency choke in the grid circuit and another in the plate circuit, but the reactances of these are assumed to be so large that they do not affect the operation of the oscillator, that is, in respect to frequency.  $C_p$  is the plate to cathode capacity,  $C_g$  the grid to cathode capacity,  $C_m$  the plate to grid capacity,  $C$  the grid condenser, and  $L$  the inductor. The internal resistances are represented by  $r_g$  and  $r_p$ .

Now in most practical cases the internal resistances are so high their effects on the frequency can be neglected. Therefore the oscillating circuit is the network remaining when these resistances are removed, and the frequency of oscillation can be computed in terms of the capacities and the inductance. First of all,  $C_p$  and  $C_g$  are in series. Therefore their capacity is  $C_p C_g / (C_p + C_g)$ . For short, let us call this  $K$ . Across this capacity is the grid to plate capacity  $C_m$ . Therefore we have  $K + C_m$ . This in turn is in series with  $C$ , and therefore the total effect capacity in the







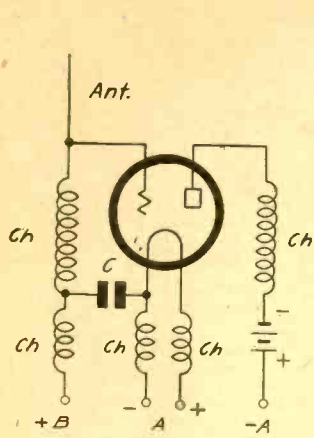

FIG. 4

The circuit of the Barkhausen-Kurz oscillator. It is characterized by having a high positive potential on the grid and a low negative potential on the plate.

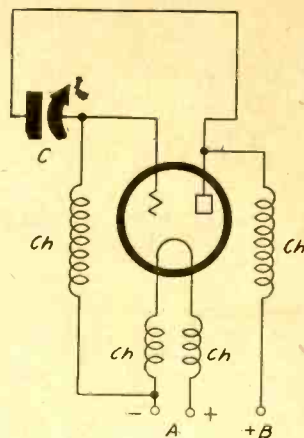

FIG. 5

A simple oscillator of the type in Fig. 1, a single-turn loop of wire being used for inductance and the grid stopping condenser being used for tuning. Tube capacities not shown.

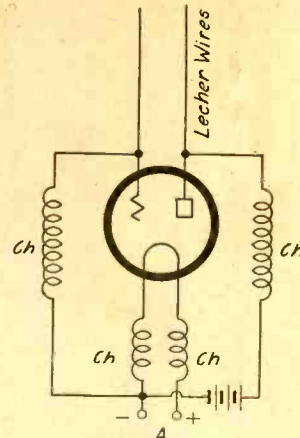

FIG. 6

In this oscillator, which is of the ultraudion type, the inductance coil has been replaced by a pair of Lecher wires. This can oscillate whether the far end of wires is open or closed.

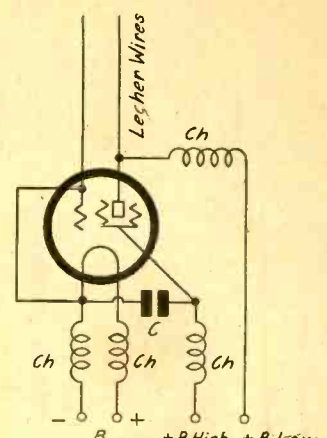

FIG. 7

This circuit is a dynatron in which a pair of Lecher wires has been substituted for the usual resonant circuit. The wavelength generated is always longer than the wavelength of wires.

circuit, that is in series with the coil, is  $C(K+C_m)/(C+K+C_m)$ . Let us call this  $K_e$ , the effective capacity in series with  $L$ . Therefore the frequency of the circuit is  $F=0.159/(L K_e)^{1/2}$ , or the wavelength is  $\lambda=1.884(K_e L)^{1/2}$ ,  $\lambda$  being measured in meters,  $K_e$  is microfarads, and  $L$  in microhenries.

Let us apply this formula to an assumed case, using values that are likely to occur in practice. Let  $L=1\mu H$ ,  $C=5$  mmfd.,  $C_g=C_m=1.7$  mmfd., and  $C_p=3.8$  mmfd. Therefore  $K=1.175$  mmfd.,  $K+C_m=2.875$  mmfd., and  $K_e=1.826$  mmfd. When we substitute this value in the wavelength formula we obtain  $\lambda=2.55$  meters. This is about the lower wavelength limit of oscillation of an ordinary tube. Of course, it may be possible to lower the inductance as well as the value of  $C$ , but there will be a combination at which the oscillation will stop.

By removing the socket and connecting the leads directly to the prongs on the tube, lower wavelengths can be obtained for the same value of inductance. However, the capacity values chosen above were for the tube alone and not including the capacities of the socket. The radio-frequency chokes used in the grid and plate circuits will have some capacity, and these will make  $C_p$  and  $C_g$  larger than the values selected. Suitable coils might have a capacity of one micromicrofarad, and this would make the value of  $K$  1.73 mmfd. in place of 1.175 mmfd. Thus if nothing else were changed, the wavelength would be 2.7 meters. The change is not great.

By removing the base on the tube the tube capacities can be reduced considerably, but even this change will not affect the frequency a great deal. One of the best ways of reducing the capacities is to bring the grid and plate leads out at opposite sides of the tube. Special tubes for short-wave generation are constructed in this manner. It should be noted that if the grid-cathode and plate-cathode capacities were zero, there could be no oscillation. Making them zero, however, is impossible. Hence there is no danger of making them too small.

### Range of Oscillator

It is clear that the frequency range of an oscillator such as is represented in Fig. 1 is very narrow for the variable condenser has a small effect on the total effective capacity. Let us see what the possible range is. The largest possible value of  $C$  is infinite, that is, the value it has when it is shorted. If we set  $C$  in the formula for  $K_e$  infinite we have  $K_e=K+C_m$ . Using the value previously computed for  $K$ , we have  $K+C_m=2.875$  mmfd. The wavelength is 3.2 meters. The smallest value that  $C$  can have is zero. But when it has that value the  $L$  branch of the circuit is open and there can be no oscillation. But we might set a lower limit of one mmfd. for  $C$ . The  $K_e=1.741$  mmfd. This makes the wavelength 1.62 meters. Still it is not down to one meter, and we have no assurance that the circuit will oscillate.

The ultra-short wave oscillator can take many external forms, but most of them can be represented by the drawing in Fig. 1. In Fig. 2 we have a circuit that is sometimes used in short-wave oscillators and it is supposed to be a Hartley. When the same circuit is used with two tubes in a kind of push-pull arrangement it is called a "balanced Colpitts." It can be neither a Hartley nor a Colpitts as it stands, but it can be converted to a Colpitts by the simple expedient of connecting a radio-frequency choke in the  $B$  supply lead. The circuit in Fig. 2 can be represented by a network such as that in Fig. 3, the internal resistances of the tube being omitted. From either Fig. 2 or Fig. 3 it is plain that the circuit is doubly periodic, that is, it has two tuned circuits both con-

tributing to the frequency. If a choke is put between the tap on the coil and ground, that is, the point where four condensers join, the circuit becomes a Colpitts. When this choke is put in, the circuit is essentially the same as that in Fig. 1, that is, the ultraudion.

In Fig. 7 we have a simple oscillator in which the inductance consists of a small, single turn loop. A radio-frequency choke is put in each of the filament leads and in each of the grid and plate leads. The tuning condenser  $C$  is the grid stopping condenser.

This circuit is exactly like that of Fig. 1 and the frequency can be estimated by exactly the same formula as was developed in connection with this circuit. The inductance is principally that of the loop. Suppose we have a loop in the form of a circle ten inches in diameter and made of a copper wire  $1/8$  inch in diameter. What is the approximate frequency of the oscillator, assuming that the total effective capacity 2 mmfd. as computed from the formula for  $K_e$ ? First we have to compute the inductance of the loop. This is 0.7 microhenry. Therefore the frequency of the circuit is 130 megacycles, or the wavelength is 2.3 meters.

If we had bent the wire into a square, the inductance would have been 0.675 microhenries, assuming we used the same length of wire and the same diameter. This it does not make much difference if the circle is not perfect.

The chokes should be suitable to the high frequency. Those in the filament leads must be able to carry the filament current and all must have a low distributed capacity.

### Lecher Wire Oscillators

In principle, Fig. 6 is exactly the same as the oscillator in Fig. 5 and the frequency of oscillation is determined in the same way. That is, the formula developed in conjunction with Fig. 1 applies, provided that we substitute for  $L$  and  $C$  the equivalent values of the Lecher wires. We shall not attempt here to find the equivalent. It depends on whether the wires at the far end are shorted or open. It is possible for the circuit to oscillate either way, but the frequency will not be the same in the two instances. Oscillation will occur more readily if the wires are shorted, but if they are it is necessary to insert a blocking condenser to prevent the  $B$  supply from shorting. A condenser of about 0.002 mfd. can be inserted in either lead without making any appreciable difference in the frequency. In Fig. 7 is another Lecher wire oscillator, but in this case the tube is connected as a dynatron. The circuit oscillates by virtue of secondary emission from the plate, or by virtue of negative resistance. Now we have only one tube capacity to consider, that between the plate and all the other electrodes. This capacity, however, is much larger than the effective distributed capacity in the previous case. As in that case, the frequency will not be determined solely by the characteristics of the Lecher wires, but it will be lower.

In Fig. 4 we have the Barkhausen-Kurz oscillator. The characteristic feature of this is that the grid is highly positive and that the plate is at zero potential or at a low negative potential. The short wire projection from the grid is not a part of the oscillating circuit but is used only as a means of detecting the presence of the oscillations or for radiating them. The real oscillating circuit is entirely inside the tube, the oscillation consists of a back and forth movement of electrons in the space between the grid and the plate.

The frequency of these oscillations depend mainly on the voltage on the grid, the higher this voltage the higher the frequency. The variation is approximately as the square root of the grid voltage.

(Continued on next page)



down to avoid overloading the triode, for it was found that more could be taken out, due to the higher gain, when the lower bias prevailed and signal was reduced accordingly, than when the higher bias existed, and the signal was permitted to enter the audio channel at maximum.

Also, the plate load resistor is now recommended to be much higher, the total resistance being in excess of 100,000 ohms, almost invariably. In the circuit herewith the effective plate load resistor is 50,000 ohms, but there is an additional resistor of 100,000 ohms, from which the signal is removed by a large capacity (8 mfd.), and besides this combination of 0.1 meg. and 8 mfd. constitutes an important hum filter. One of the worst places for hum trouble is at the detector, and this filter prevents the hum from backing into the detector through the plate circuit that is otherwise open to the reception of hum with a vengeance.

### One-Sixth of Amplitude Omitted

Let us examine the input to the two diodes. The usual intermediate-frequency transformer is present, and its secondary will be considered. From the upper or high side, looking into the 55 duo-diode, there are two condensers. The capacities are the same, 0.0001 mfd. One condenser, the upper one, connects directly to the upper diode plate, and then there is a resistor of 0.1 meg. that continues from that point in the direction of the cathode. However, a resistor of 0.5 meg. goes to the cathode, and therefore the total resistance, looking from the condenser just mentioned, to the cathode, is 600,000 ohms, or 0.6 meg. This total expresses the load used for the detector itself, the so-called second detector or demodulator, and the tube depended on for the audio frequencies to feed the following channel.

But we must realize that the rectification affects the total 600,000 ohms, and since a slider moves across the 500,000 ohms (0.5 meg.) to grid of the triode in the 55, reached through a condenser, it is obvious that not all of the rectified voltage is delivered to the triode. In fact, the total voltage is represented by 600,000 ohms, and that taken off is represented by 500,000 ohms at "full-on" position of the manual volume control, therefore one-sixth of the rectified voltage is not utilized at all. The reason is plain enough. If that other sixth were added to the input to the audio amplifier there would be premature overload of the audio channel. Besides there might be some intermediate-frequency oscillation, because the amplitude at the detector affects the oscillatory tendency of the intermediate channel, always dangerously high unless special safeguards are taken.

### Delay Voltage

From the pointer through a condenser to the grid, with grid return through 2 meg. to ground, represents the input, while the output is effectively that developed across the 50,000 ohms, being fed to the primary of the interstage audio transformer.

Thus have we accounted for the second detector.

Perhaps as good a name as any for the purpose to which the other diode is put is third detector, though the service rendered is automatic volume control. What is the advantage of this severance? Are not the functions usually combined? Why not stick to the simpler method of using the same detection for second and third detection, that is, for demodulation and also for automatic volume control?

Answer: If the functions are separated it is possible to introduce a delay voltage quite easily, of such a type that the automatic volume control will not start functioning prematurely, but will be ineffective until the signal itself has risen to a certain amplitude, when the service that a.v.c. offers is most important. In other words, while it is true that the considerations just put forward, that too much could be delivered to the triode, whereby that tube would overload, do prevail, a.v.c. may be introduced to check that tendency, but when a.v.c. is the rule, and is untamed, the danger is there will be too much of it.

While a.v.c. is never effective unless and until there is a signal of some ratable amplitude, yet it may become effective at a signal amplitude too low for the intentions. In other words, the drain on sensitivity may be too great.

It is a fact that one of the attributes of a.v.c. is that it tends to correct for fading, but in practice this benefit is not as great as some imagine, and therefore steps are taken not to permit a.v.c. to constitute too much of a drain on the sensitivity of the receiver to serve a largely theoretical no-fading purpose. That means of checking a.v.c. is developed through delay voltage, or time lag, or holding back the a.v.c. action until the amplitude for detection proper is of a sufficiently high level. All these views or aspects of the situation paint the same picture. A.v.c. is made to trail after detection, and is not introduced until considerable detecting amplitude is reached.

### How the Bias Arises

Suppose, then, that the negative bias on the triode of the 55 is made 10 volts. Then there is no danger of overloading the 55 until the signal exceeds 7 volts (an assumption that again is over-cautious). At this point, however, the a.v.c. is made to function, and when the signal itself tends to raise its head above 7 volts, a.v.c. comes along and bows that head as if with a yoke on the neck, reducing the i-f amplification until no more than 7 volts ever get into the triode. Therefore the circuit

is protected at the triode of the 55, the most vulnerable point, and though overload may occur subsequently, still it is not of the signal-stopping type, and besides one always has the manual volume control at his command in the event the signal is heard too loudly and too roughly for comfort.

It has been stated that the 55 triode is negatively biased. This is true because there are a resistor of 800 ohms between cathode and ground, and another resistor from B plus to cathode (50,000 ohms) that sends B current through the biasing resistor independent of the plate current of the tube, and thus the 10 volts are developed, the grid being returned to grounded B minus. Moreover, the bias does not depend entirely on the plate current of the 55 triode but strongly on the bleeder, which thus acts as a stabilizing agent, since the bias is steadied. Bias dependent on signal alone is unsteady.

### Input to Third Detector

We have discussed the input to one triode, the true detector, but not the input to the other diode, the a.v.c. section or unit. We found that the resistance network between the 0.0001 mfd. stopping condenser and the detector wound up at cathode for the demodulator or straight detector. Therefore whatever rectified voltage was developed was put into the triode, except one-sixth of the total which never could get into the audio amplifier.

With the a-v-c section it is quite different. Assuming a negative bias of 10 volts, measured between cathode and ground, we know from our familiarity with rectifiers that there is no possibility of rectification unless the anode goes positive. It is made positive by the signal. If the return is to a negative point, in respect to cathode, must not the signal overcome this bias before there is any rectification? Of course. Therefore we have lifted the a-v-c tube 10 volts above ground or B minus potential, and required that the signal itself be more than 10 volts before a.v.c. is introduced at all. We find that out by examining the 2.0-meg. load resistor of the a-v-c diode. It is returned to B minus, which is 10 volts negative in respect to cathode. The second detector resistor network was returned to cathode for immediate effect of detection, but the a-v-c load resistor is returned to ground, for a delayed voltage equal to the bias.

The method is similar to that used in Atwater-Kent receivers. It is more or less standard with this manufacturer, although the A-K circuit is quite different from the one illustrated. The principle of delay is there, however.

### Antenna and Coupling

It is only in respect to the 55 tube that the commercial receiver is somewhat similar, but by no means identical. The rest of the circuit differs entirely from the commercial model just mentioned.

The circuit herewith portrays an all-wave receiver, using a built-in matching transformer of the step-up type, with primary rotatable for alteration of coupling, and with a condenser in series with the split secondary. Ahead of this primary is a transposition line of the standard type, leading to the stepped-down secondary of a transformer that is situated at or near the doublet antenna. The doublet may consist of a total of 40 feet or so of wire as high as possible, supported by masts, with an insulator at center separating the two severed stretches. The theory and practice of the installation of such a transmission line, with step-down transformer theory and purposes at the antenna and step-up transformer purposes at the feed to set were explained in detail in last week's issue, dated April 7th.

If the coupling is loose, as it will or should be, then one may escape with merely one tuning stage associated with the pre-selector tube proper, for the tuning of the input transformer is the equivalent of another tuned circuit, at short waves at least, hence the coil problem is solved more easily.

### The Output Stage

The coupling between 56 oscillator and 58 modulator is made by a condenser effect resulting from a piece of insulated wire held close to one grid wire by spaghetti and close to the other grid wire by the same means.

The intermediate channel is standard, and the values will be found on the diagram.

Passing to the driver, we find the 56 feeding 2A3 push-pull tubes. Care should be taken to adjust the biases independently on the 2A3's, if need be, to adjust the plate voltage through series resistance, until the plate current through one tube is exactly the same as that through the other, to avoid hum.

Something of a novelty is the inclusion of the speaker field, only 300 ohms, in the negative leg of the rectifier, and connection of the power tubes' return so that the potential difference across this field supplies the negative bias of around 55 volts or so, while the main filter choke is an independent unit, marked 30 henries, the d-c resistance of which is not very material, except that in the interest of good regulation of the B system, the d-c resistance of this choke should not be more than 1,000 ohms.

A circuit of this type will be found to yield excellent results, and may be adopted, from first intermediate on, for almost any a-c receiver. The coil problems for all-wave coverage, and how to obtain a satisfactory switch, are other considerations. They are important, but they are beyond the scope of the present article, which deals mainly with splitting up the diode uses of the 55 and establishing a safeguarded input to the audio amplifier.



# SHORT-WAVE OSCILLATORS

## Single-Pole Switching for Five Bands— Station Finder

By Leonard Hopkins

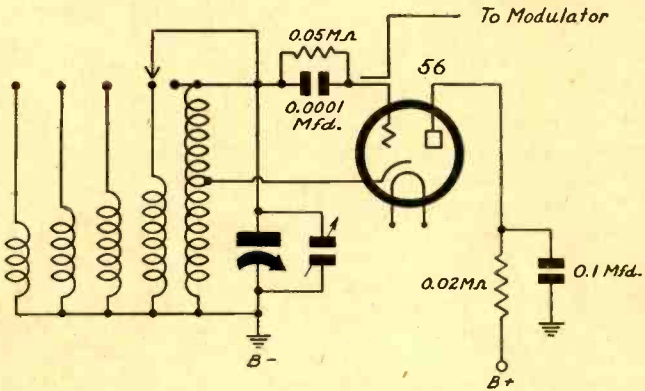

For use in a receiver having switch-operated coil systems, the oscillator switching may be reduced to a single pole by using the method outlined.

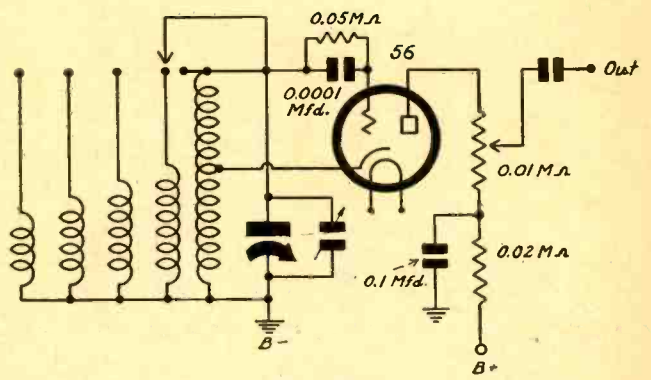

For test oscillator service the same single-pole switching arrangement may be used by following this diagram. The oscillator is not modulated.

THE Hartley oscillator is a popular one for short waves. If this type of oscillator is used with a heater tube, such as the 56, then it is possible to switch to various bands by using a single-pole switch. The number of throws or positions of the switch of course will depend on the number of bands to be covered, in this instance five. The upper diagrams show how this is done.

The lowest-frequency coil has a tap about one-quarter the total number of turns from the return end, and this tap is connected to cathode. If successive coils are paralleled with the low-frequency inductance, one at a time, the frequencies generated will be higher, and the inductances are selected on the basis of Ohm's law, or may be done experimentally.

The formula for the parallel inductances is the same as that for parallel resistors, assuming there is no mutual inductive coupling between the two coils. This formula, in words, is that the resultant

is the reciprocal of the sum of the reciprocals. Let the low-frequency coil be L and let the coil next to it in either diagram above be L1, then the resultant inductance Lx is

$$\frac{1}{Lx} = \frac{1}{L} + \frac{1}{L1}$$

To ascertain the necessary parallel inductance for reduction to cover the next highest frequency band, with a bit of overlap, we obtain the frequency ratio for the low-frequency band. Say it is 2.1. We square that and get 4.61. The required inductance for no overlap is 1/4.61 of the low-frequency inductance, which must be known. The usual commercial plug-in coil for the low-frequency band (200 to 85 meters) (0.00014 mfd. tuning) has an inductance of 70 microhenries, approximately. Therefore the required inductance for the next band would be 70/4.61. To attain overlap we reduce the denominator to 4.6 and get the required inductance as 15.2 microhenries, approximately. Therefore we must ascertain what inductance must be paralleled with 70 microhenries to yield a resultant of 15.2 microhenries. The simplified formula for this is:

$$Lx = \frac{L \times L1}{L - L1}$$

where Lx is the unknown parallel inductance, L is the known inductance of 70 microhenries and L1 is the known inductance of 15.2 microhenries. Hence Lx = 17.6 microhenries.

### Output Measurement

The same procedure is applied to the next band, 70 microhenries retained, the required net resultant inductance being 15.2/4.6, or 3.3 microhenries, the value of Lx being 3.6 microhenries.

The oscillator at upper left is intended for service in a receiver, and the method of coupling is to run a wire from close to the grid wire of the oscillator to close to the grid wire of the modulator. A piece of spaghetti into which the two wires at each grid are inserted, without touching metalically, will do nicely for holding.

The oscillator at upper right is for testing. It is not modulated. However, an output meter may be used on the device being tested, say, a receiver, and the deflection will show up all right. Modulation is necessary mainly for audibility, but a meter dispenses with any requirement of audibility for lining up.

### Bands Covered

The diagram below is for a test oscillator, also unmodulated, using plug-in coils. It may be used as a station finder by loose coupling to aerial, as may the diagram at upper right. The 2-volt designation near the A battery should be read as applying to the filament, that is, between the upper end of the 16.7-ohm resistor and the filament point where the switch makes contact. The battery voltage is 3 volts, not 2 volts. The difference of one volt is dropped in the filament limiting resistor.

Standard plug-in coils, with a condenser of the proper capacity (usually 0.00014 mfd.) will cover the necessary bands, and no construction or calculation of coils is necessary.

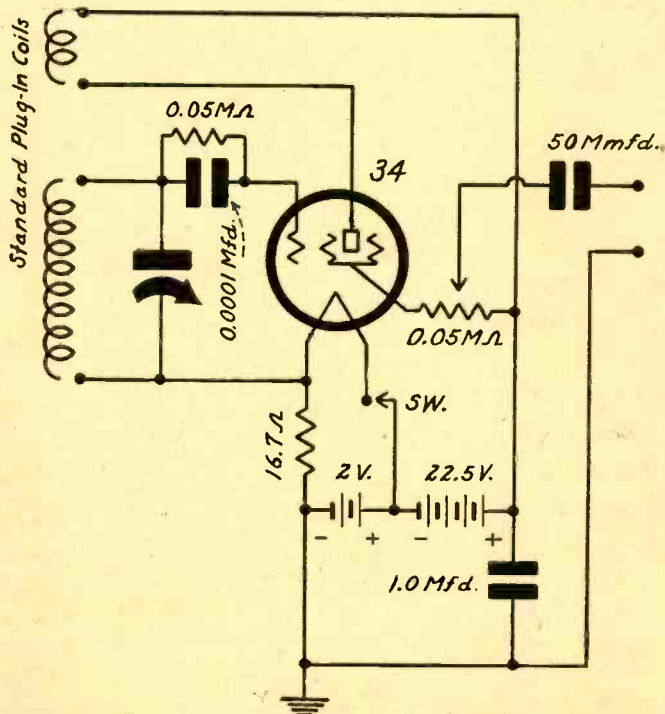

A test oscillator, using plug-in coils, may be constructed from this pattern. The A battery voltage is 3 volts, and the designation "2 volts" should be read as applying to the filament of the 34 tube.



# A Short-Wave Universal

## Earphone-Speaker Set Uses Three Tubes, One Being 37 as Rectifier

*By Samuel Fender*

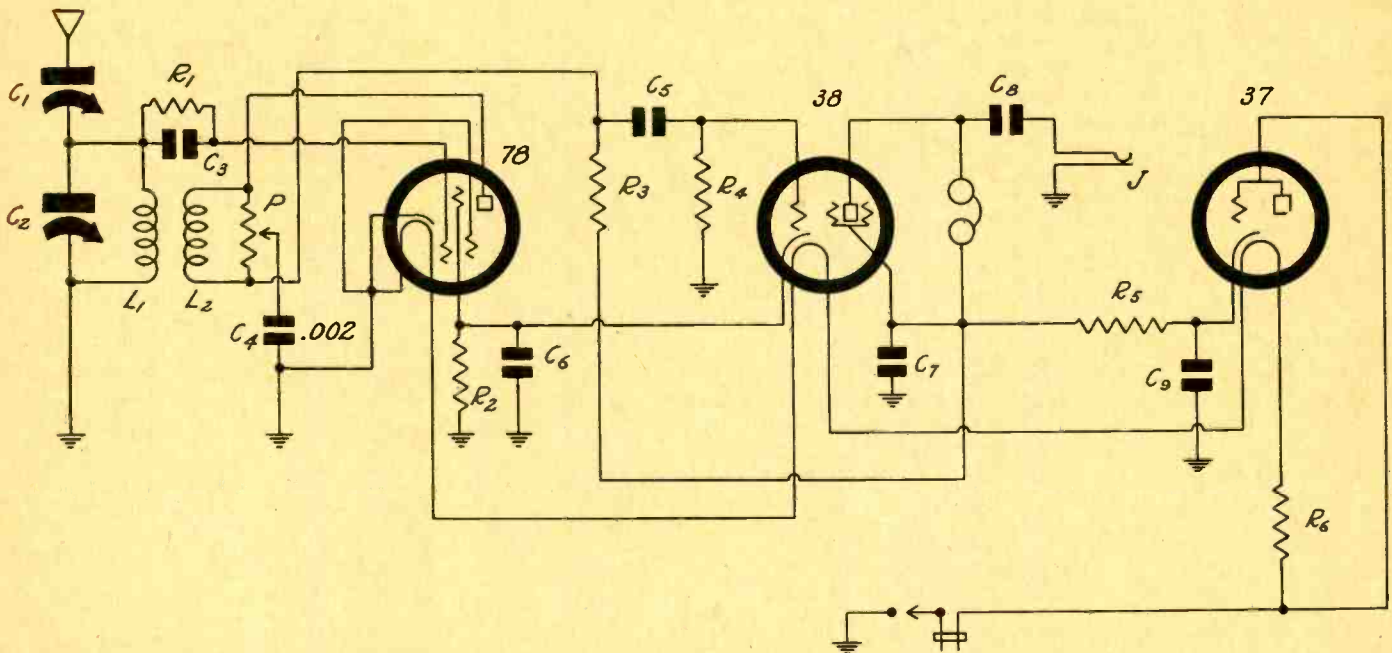

Simple indeed is this universal set for short waves. Some stations come in loud enough to be heard on the speaker. Others do not. It is mainly an earphone type receiver.

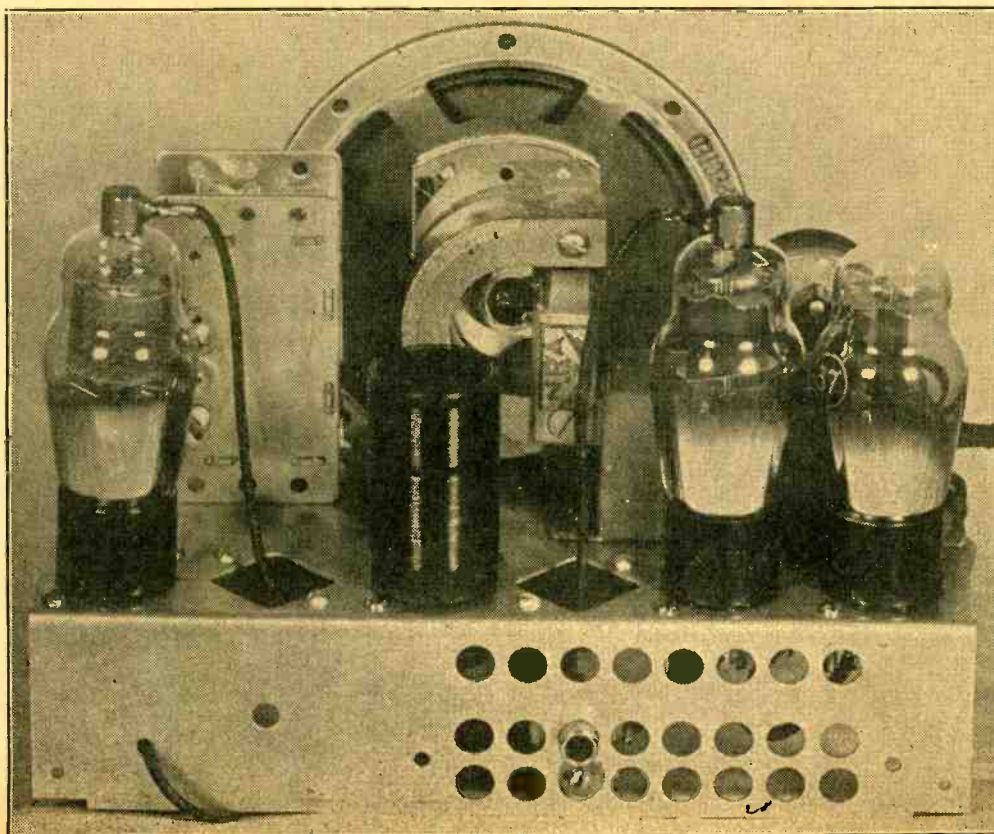

View of the Universal Set







# DIALLING FOR ALL WAVES

## By Frequency-Calibrated Methods

By Herman Bernard

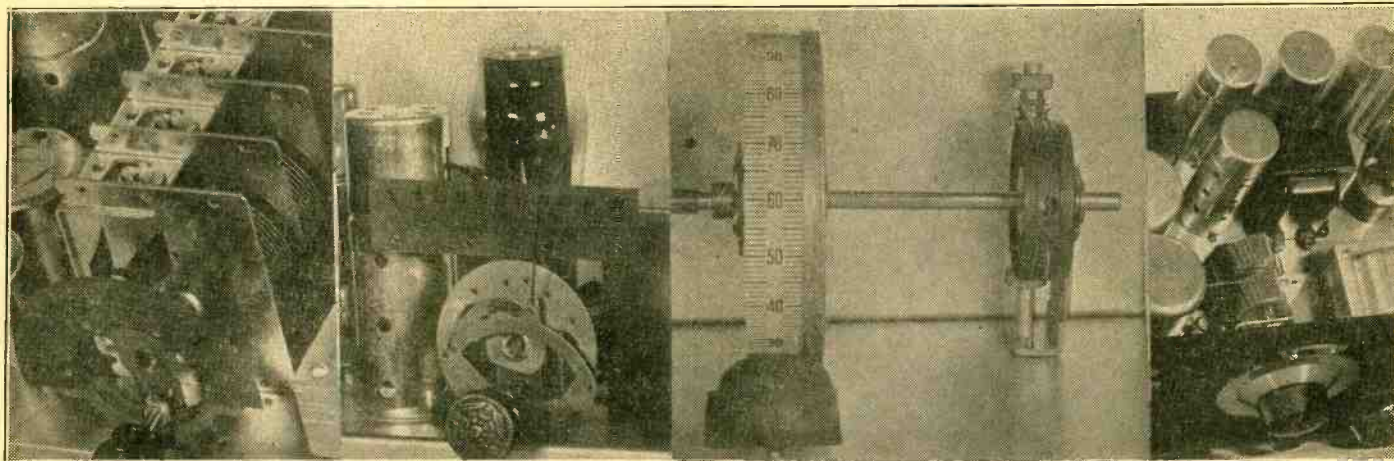

**Disc dial with traveling light, circular movement, translucent scale.**

**Cam mechanism to move the pointer over a wide arc, instead of in a circle.**

**The drum dial offers the best advantages for multi-wave calibrations because the same linear distance applies to all bands.**

**A true vernier dial, serviceable if the tuning is linear and the ratio 2 to 1.**

**T**HE illustrations show four types of dials, and the question is as to their application to frequency-calibrated short-wave or all-wave receivers.

The first type, at left, is the disc dial of the traveling light type. Obviously there is not enough room on the illustrated model for the imprinting of four or more tiers representing the scales for as many bands of tuning. However, if the size of the scale as shown is representative of the broadcast band, the scale could be enlarged to accommodate other bands, it being preferable to have the higher frequencies calibrated nearer the periphery, although the opposite is the practice in commercial all-wave receivers, where the broadcast band no doubt is deemed the most important.

The transparency or translucency used as scale is not very satisfactory for retaining calibration, and as it is subject to warpage, and an etched metal scale would be preferable. That would rule out the traveling light at rear and require that it be at front to illuminate the scale, and, preferably, to illuminate only the particular scale representative of the band in which the tuning is then being done.

### Serving Convenience

So the illumination would have to be associated with the coil-switch, for it is assumed that switching would be a necessary counterpart to any system using frequency calibration that is direct-reading. In other words, if convenience is to be served, it must be served consistently.

The second dial from the left represents an easier solution, in that the pointer moves over a wide arc, and by some enlargement of the scale there would be plenty of room for extra bands. However, the pointer is not of the accurate type, being subject to considerable parallax, but the scale could be etched metal, and the danger of warpage then would be eliminated. Since there is no necessity for the indication appearing through the scale, the metallic method becomes entirely practical.

The pointer does not move along a horizontal line in the dial illustrated, although there is a pulley-drive dial, made by National Company, that performs the same general service, extends over a much wider area, and does move on a horizontal line.

Notice in the illustration that the bars tip over, representing the effect of the arc described by the pointer. The dial is popular in inexpensive short-wave receivers, using plug-in coils, but frequency calibration invariably is omitted, as requiring a higher degree of skill in preparation and manufacture of the tuning parts than is to be expected from such an inexpensive device. The dial itself has excellent action.

### Drum is the Thing

The drum comes closer to a solution than any other system, because no matter how many bands there are, the same scale space is afforded to each band. Thus as there are eight inches for imprint-

ing the broadcast band, there are eight inches for imprinting the 10 to 20 meter band, or a lower wave band, or any other band. This is because the tiers are not disposed concentrically.

The precision type dial shown at right is of the true vernier type, meaning that there are the usual gradations on the scale, and a device that permits reading fractional parts of one division. The dial is National Company's and has 100 divisions for a condenser rotation of 180 degrees, the vernier enabling reading any one division in tenths, so that for 100 divisions thus subdivided the 180-degree rotation is dissected into 1,000 parts.

This method applies to a short-wave or all-wave receiver of the frequency- or wavelength-calibrated type, only if the condenser used is truly straight frequency line, or truly straight wavelength line. The meaning of these terms is that for a given distance anywhere on the dial the difference in frequency or wavelength is the same as for the same displacement anywhere else on the dial, or, that the change is linear.

### Really SFL Condenser Coming

Up to the moment of writing there is no strictly straight frequency line condenser on the market, although one is in preparation. The trouble has been that the theoretical plate shapes do not work out strictly in practice. Usually there is serious divergence at the low-capacity tuning end, due perhaps to inadequate allowance for a definite minimum or distributed capacity in the circuit, external to the condenser, as well as perhaps to ignoring also the condenser's own minimum.

However, by the work-and-trial method, the straight frequency line can be established, at least for a particular circuit, and then the true vernier could be worked, and if the frequency ratio is 2-to-1, then the same bars could be used for all bands, only numbered by multiples, e.g., 540 to 1,080 kc, 1,080 to 2,160 kc, etc.

The present almost general method in commercial all-wave receivers of having the broadcast band covered entirely without switching would have to be abandoned in such an instance, and there is no reason why it should not be abandoned, as the general principle of establishing a certain frequency ratio as suitable for the highest-frequency band, applying this necessarily to all lower frequencies, dispenses with padding condensers that, unless expensively constituted of air-dielectric condensers, will not hold their settings. Fixed condensers selected of suitable accuracy at the time of testing do not hold their capacity, even the quantity-moulded type, due to compression and expansion of mica, and to shifting of the plates in a space into which the plates were put with non-uniform pressure.

The compression type condensers change their capacity very seriously.

When a frequency-calibrated dial is used it is customary to adopt some scheme of automatically exposing the correct scale for any given switch position. This automatic feature highly serves convenience.



# THE SKY-RAIDER: An 1

## A Straight Super for Broadcasts and

By Alan

Mannion Rad

HERE is a new style of all-wave receiver. It incorporates the idea of a short-wave converter into a broadcast superheterodyne. The conversion from a broadcast set to a short-wave set is accomplished by throwing a three-pole, double-throw switch. Fig. 1 shows the position of the switch when the broadcast section is used only. The antenna is connected to the primary of the first high-gain coil and at the same time ground is connected to the low potential side of this primary. The circuit then is a nine-tube broadcast superheterodyne with two high-gain r-f tuners, an oscillator, two stages of intermediate amplification, a diode detector, and a stage of power amplification in which there are two power pentodes in parallel.

### High-Gain Tubes

The parallel operation of the output tubes insures a high output volume without the necessity of using heavy input and output push-pull transformers. The gain of the power tubes employed, namely, the 2A5's, is so high that it is permissible to omit the intermediate audio frequency stage. Thus there are only two stages of amplification in the receiver. Still, the output of the intermediate frequency amplifier is so great that it is easy to load up the triode of the 55 to its limit, and when that is done the input to the power tubes is more than they can handle. Hence the fact that there are only two stages in the audio amplifier does not put any limitation on the volume. The limit is set by the volume handling capability of the power tubes. Long before they are overloaded the listener will say, Enough.

There is a manual volume control in the circuit, which is located in the output to the triode of the detector tube. The load resistance is a 1/2-megohm potentiometer and the grid of the triode is connected to its slider through a 0.1 mfd. stopping condenser. Since there is a stopping condenser there must also be a grid leak associated with the triode grid, and this is a fixed resistor of 0.5 megohm.

### Biasing of Tubes

The triode of the 55 is biased by means of a drop in the voltage divider. Since the current in this section of the voltage divider is large compared with the current demanded by the triode, the bias is virtually fixed. A 25 mfd. condenser is connected across this portion of the voltage divider to insure a minimum of feedback.

In addition to the manual volume control, there is automatic control, the two intermediate 58's and the r-f 58 being controlled by d-c feedback from the load resistance of the diode detector. Double filtering is employed to prevent any signal feedback by this route. That is, there are a 100,000-ohm filter resistor in each grid leak and also a 0.05 mfd. condenser in each. Then there is a 0.5 megohm stopping resistor in series with the common lead and another 0.05 mfd. condenser associated with it. Besides the automatic bias there is a fixed biasing resistor in the cathode of each a.v.c. controlled tube.

The power tubes are biased by means of a drop in a 300-ohm section of the field coil, which also serves as choke in the B supply. The total resistance in the field is 1,800 ohms and the voltage drop across the field is about 100 volts.

The intermediate frequency of the broadcast section is 465 kc and there are three doubly tuned transformers at this frequency.

### Series Padding Condenser

The oscillator for the broadcast section is of the padded type, the padding condenser being put in series with the coil on the ground side. Hence both the tuning and the padding condensers are grounded. Ease

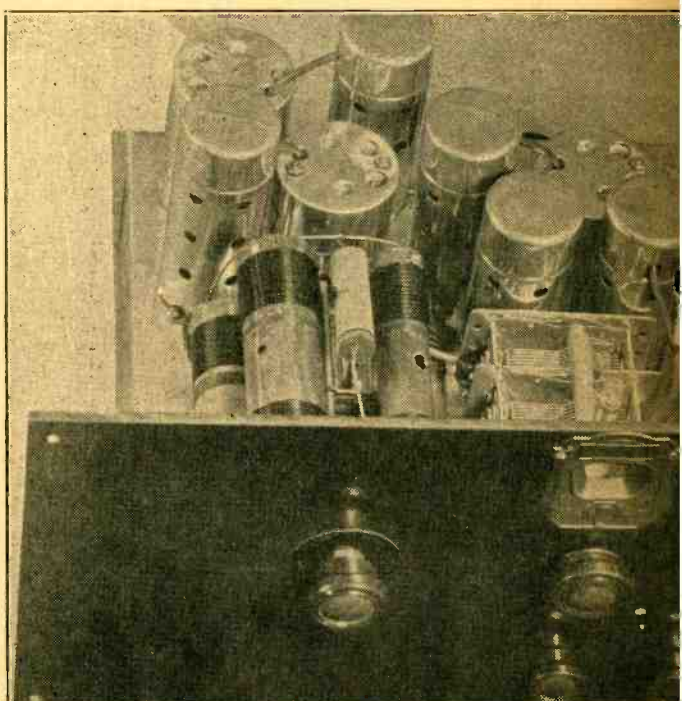
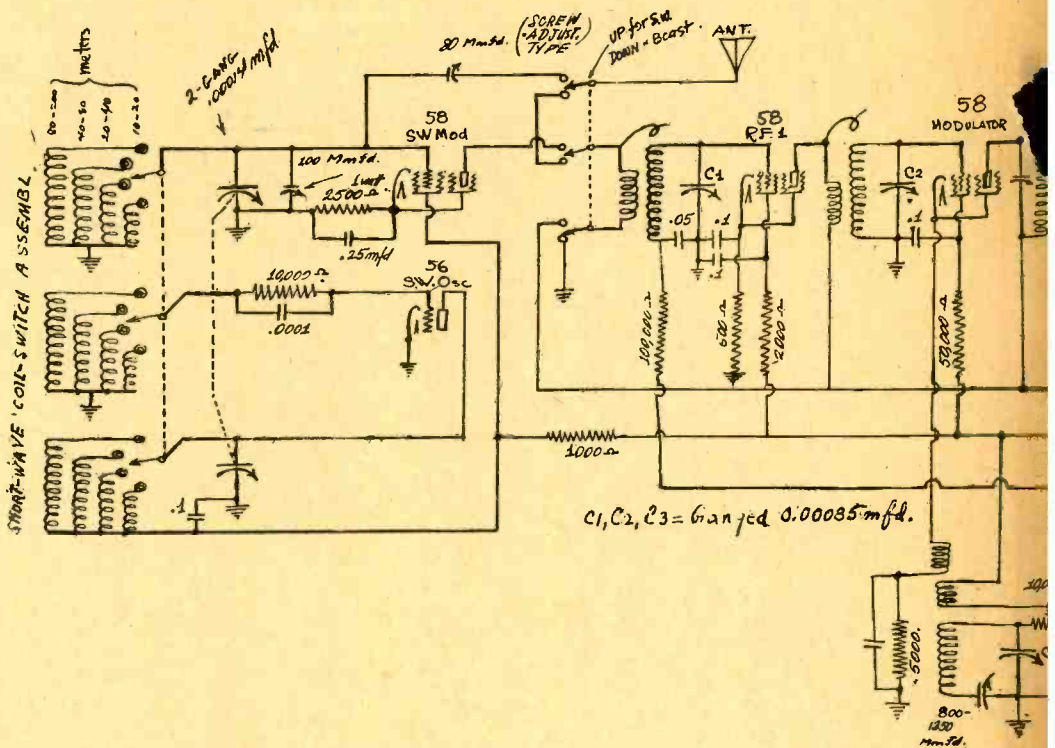

View of the assembled Sky-Raider. The coil assembly is in the middle. Above is shown the







# Selected Radio Terms Often Used but Seldom Explained

By Arnold Schaefer

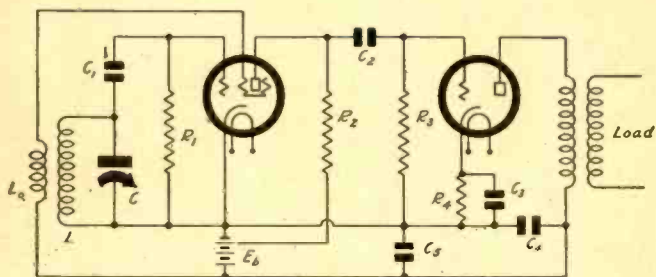

FIG. 1

The circuit of an oscillator to which the load circuit is coupled by electron coupling. The intervention of an amplifier further decreases the reaction of the load on the oscillator.

THERE is a large number of technical terms used in describing radio receivers and accessories. Some of them are definite in meaning and are generally understood, but some are quite obscure and perhaps do not deserve the distinction of being called technical terms. Let us review some of the terms and attempt to attach some meaning to them.

**Array.**—An antenna array is a combination of conductors arranged to perform a definite function, usually to achieve directivity of reception or transmission. An array might consist of a large number of vertical wires placed at definite intervals, each tuned to the same frequency and all excited by the same force in phase. Or the wires may be placed in the form of a parabolic cylinder. A very large number of different combinations of arrays has been worked out and the object usually is to obtain greater transmission or reception efficiency in a given direction.

**Transposition Block.**—A transposition block is an insulator used for interchanging the relative positions of two parallel conductors. For example, if wire A was east of wire B before the transposition block it is on the west of it after it. A two-wire transmission line in which the wires are transposed at frequent intervals, say every 15 inches, is used as lead-in in short-wave receivers for the purpose of eliminating pickup of local noise.

## Sensitivity Explained

**Sensitivity.**—This is an index of the ability of a receiver to pick up weak signals and is usually defined in terms of the signal voltage required at the input terminals to give standard output in the loudspeaker. When the sensitivity of the circuit is variable, the highest value of the sensitivity, naturally, is given as the index of performance of the circuit in this respect. Sometimes the sensitivity, so-called, is given in terms of microvolts per meter. This expression has absolutely no meaning, unless the exact characteristics of the antenna are specified. For example, the specification may be that a standard antenna is used. When the sensitivity is expressed so as to be independent of the antenna, it is called absolute sensitivity. It is really not necessary to use the word "absolute," for the definition of sensitivity implies it.

**Gain.**—The gain in a receiver or in any part is the amplification in that receiver or part. Hence there is no need for differentiating between amplification and gain. Gain, or amplification, is closely associated with the sensitivity, because the sensitivity is directly proportional to the gain. If the overall gain is known, the sensitivity is also known, for we can always determine what signal voltage at the antenna is required to give standard output.

**Volume Control.**—There are two types of volume control, manual and automatic. A volume control is really a sensitivity control, or gain control. Long before broadcasting it was known as a gain control. The gain control has nothing to do directly with the output. The change in the output as the gain is varied is due to the fact that the signal at the input posts remains fixed. When this varies and when the gain control is automatic, the volume does not change. But the gain varies continuously, and in inverse ratio to the strength of the signal.

## Selectivity

**Selectivity.**—The selectivity of a receiver is a measure of its ability to discriminate between the desired signal and all other

signals. It is not dependent on the intensity of the signal, although it appears to be so, because the ear is a very accommodating organ to intensity of sound. In expressing selectivity it is assumed that all signals at the antenna have the same strength. If the receiver is to accept a weak signal and reject a very strong one close in frequency to the desired signal, the selectivity must be very high. Otherwise the strong signal might overwhelm the weaker.

**Microvernier.**—A vernier is a device for reading a scale accurately in fractional parts of the smallest division. The term, however, has been applied in radio to devices for turning a dial slowly. In this sense a vernier is a reduction gear. When the prefix "micro" is used the meaning is that the ratio is great, or that it requires the turning of a knob through many degrees in order that the rotor coupled to it should turn a small amount. The vernier need not be mechanical but may take the form of a small variable condenser across a very large one, or a very large variable condenser in series with a small one.

**Bandspread.**—This refers to a capacity vernier, usually, connected across a larger variable or fixed condenser. The purpose is to spread out the dial readings for a certain narrow band of frequencies. The main condenser may cover a band of two-to-one, whereas the bandspread condenser may not cover more than 10 per cent. of this band. Thus 10 per cent. of the band is spread out over the entire scale of the vernier condenser. This does not help selectivity for it does not change the circuit. Neither does it help tuning any more than a slow motion dial would do, but it does it just as well and at the same time it allows close reading.

## Backlash or Lost Motion

**Backlash.**—Is a mechanical imperfection in the coupling between the driver and the driven members of a gear or other mechanical coupler. It means that the driver must move a certain distance or angle before there will be any motion in the driven member. Such imperfection does not interfere with calibration of a dial unless the dial is placed on the driver. If an attempt be made to magnify a change of angle, for example, by putting the dial on the driver, and there is lost motion or backlash between the driven and driver members, large errors will creep in and no two readings of the same thing will be the same. Because of backlash it is preferable to spread out readings by using a condenser vernier.

**Electron Coupling.**—When the screen of a screen grid tube is used for anode in an oscillator and the tickler is connected in its lead and the load circuit is connected to the plate, usually without any voltage on the plate, the load is said to be coupled to the oscillator by electron coupling. While other applications have been made of the term, this was the arrangement used by Jennings B. Down, who coined the phrase. When this coupling is used energy is delivered to the plate only by electrons which are hurled to the plate by the screen. The screen attracts electrons, giving them a high velocity, but it fails to catch all of them. Some of them reach the plate by virtue of their high velocities. There is no "back talk" from the plate and for that reason the load does not influence the frequency of oscillation to any appreciable extent.

## Power Output

**Power Output.**—While the power output of a receiver or amplifier should be the power that is radiated into sound, the usual meaning of the term is the power that is delivered to the load resistance on the last tube. The load is supposed to have the optimum value for the particular tube used. The maximum undistorted power output is the power delivered to this impedance when the amplitude of the signal on the grid is equal to the grid bias on the tube. An arbitrary limit of 5 per cent. total distortion is usually set. That is, if the total distortion does not exceed 5 per cent. of the first harmonic output the signal is regarded as distortion free.

**Power Factor.**—The power factor of a circuit is the cosine of the time angle between the current and the voltage in the circuit. It is the ratio of the useful power to the total power involved in the circuit. If a circuit is to work at greatest efficiency the power factor should be unity. That is, the voltage and the current should be in phase. In a coil or condenser designed to be used in a tuner, the power factor should be as low as possible. That is, there should be no resistance in either the condenser or the coil in order that the current and voltage be 90 degrees out of phase. When they are the tuned circuit formed out of this condenser and this coil will be perfectly selective.

## Calibration in R's

**The R's.**—Recently vacuum tube voltmeters have been offered for sale and one of the inducements is that they are calibrated in R's. What is an R? The amateur knows, for he uses it. There is a scale by which signal strengths are estimated and it R1, R2,



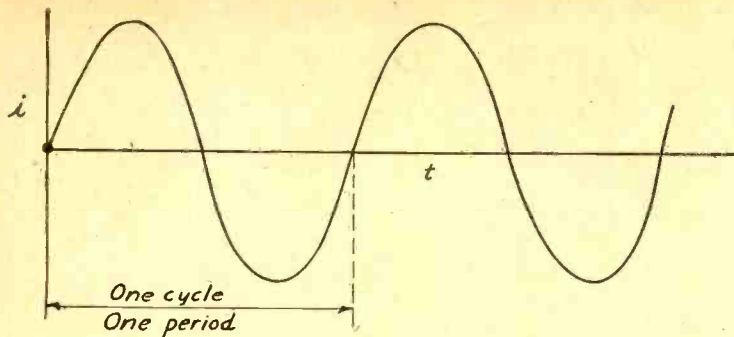

FIG. 2

Two cycles of an alternating current plotted as a function of time. Current is in the positive direction above the times axis and in the opposite direction below.

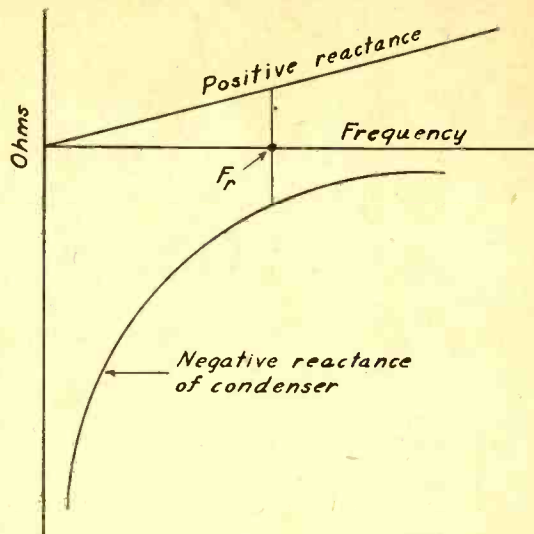

FIG. 3

This illustrates the way reactances of coils and condensers vary with frequency. The condenser reactance is below the frequency axis and the coil reactance above.  $F_r$  indicates frequency of resonance.

R3, and so on up to R9. The higher the number that is attached to the R, the stronger the signal. It is an arbitrary and inexact scale, for it is largely a matter of judgment just what R-number to ascribe to a given signal. Yet for practical purposes it serves well. When one amateur tells another that the signals of the latter are R1, he is no doubt exaggerating, for if they were as weak as represented by that number he would probably not be able to identify them. Yet the information is enough to convey the idea that they are entirely unsatisfactory. When he tells that the signals are R9 he may still be exaggerating, but at least the sender will know that they come through very well. Calibrating a vacuum tube voltmeter in R's is an attempt to eliminate the judgment factor and put the scale on an as nearly exact basis as possible.

Velvet tuning.—As the name implies it refers to smoothness of control of the tuner. A velvet dial does not turn the condenser in jumps but smoothly and surely.

**Shielding and Grounding**

Shielding.—When a coil, condenser or other device in a radio receiver is protected from the fields surrounding other devices it is said to be shielded. It may not be. A metal can surrounding a coil may not shield that coil from other devices, and they in turn may not be protected from that coil. But as a rule, a metal can or box around a coil or condenser will reduce coupling. If the shielding metal is thin, electromagnetic induction goes through, but the shielding effect increases rapidly with increase of thickness of the shielding metal.

Grounding.—In most radio receivers the low potential side of the circuit is connected to the metal chassis. The idea is that the chassis is at ground potential and therefore the device connected to it will also be at ground potential on the side connected to the chassis. But it is a fact that large currents may flow through the chassis from point to point, and not all points will be at the same potential. A ground is a very deceptive term. It is only in extreme cases that the current in the metal chassis will give rise to any trouble.

Litz.—A type of wire used for low-loss coils at intermediate frequencies. Litz is an abbreviation of Litzendraht, a German word meaning lightning wire. It is composed of a large number of fine insulated strands, often No. 38 enamel. These are twisted together in different ways. Sometimes a bundle of ten or twelve is twisted and then a number of these "ropes" are twisted together, the whole covered with silk insulation. There is little advantage in using Litz for broadcast frequency coils and an actual disadvantage in using it for short-wave coils. The radio-frequency resistance is higher than for solid wire.

**Frequency and Periodicity**

Frequency.—The frequency of any regularly recurring phenomenon is the number of times per second it occurs. If the phenomenon is an alternating current in a circuit, the current will be at zero at a certain instant. Then it will rise to a maximum value when it will return to zero. Then it reverses direction and attains a maximum in that direction and once more in returns to zero. This series of events is a cycle. The number of these cycles per second is the frequency. It requires a certain time for the current to go through a cycle. This time is the period. The periodicity is only another name for frequency and means the number of periods per second.

A harmonic as generally understood in radio is a frequency which always is greater than the fundamental by an integral multiple. The first harmonic is the fundamental, the second has a frequency

twice the fundamental, the third, three times, and so on. Harmonics must be produced by the same source for otherwise there might be a difference in frequency.

When zero beat occurs in a circuit where two different frequencies are present, one of the harmonics of one is equal to some harmonic of the other. The fundamentals of the two need not be the same. For example, one fundamental may have a frequency of 100,000 cycles and the other 150,000 cycles. The fundamentals cannot produce zero beat and the first possible beat is that between the third of the first and the second of the second. Each of these harmonics is equal to 300,000 cycles. If one of the frequencies is held constant and the other is varied continuously, there will be many values of the fundamental of the variable frequency at which beats will occur. If  $F$  is the frequency of the fixed oscillator and  $f$  the frequency of the variable, beats will occur whenever the equation  $f = nF/m$  is satisfied,  $n$  and  $m$  being whole numbers. Here  $m$  is the order of the harmonic of the variable frequency and  $n$  the order of the harmonic of the fixed frequency. It is clear that there is an indefinite number of values which will satisfy the equation, and that  $f$  may be both increased and decreased.

**Units and Concepts**

Potential.—Electric potential is the work done in moving a unit charge of electricity from a point infinitely far away to the point where it is, against the electrical forces. The potential difference between two points is the difference between the work done in moving the unit charge to the two points, or more explicitly, it is the work done on the unit charge in moving it from one point to the other against the electrical forces. The practical unit of potential is the volt. Therefore voltage is potential or potential difference expressed in volts.

Current.—Current is the time rate of change of charge or the rate of flow of charge past a point in the circuit. It is usual to think of it in this way when charging batteries. It applies equally well to the charging of a condenser.

Resistance.—Resistance is electrical friction in a conductor—an obstruction to the flow of electric charge. The power when current flows through a resistance is the product of the resistance and the current. The work done on the resistor is product of the resistance and the quantity or charge.

Impedance.—The impedance in an alternating-current circuit is the total obstruction offered to the current. It is composed of resistance and reactance.

Reactance.—The reactance is that part of the impedance which opposes changes in the current. When the current is d-c, there is no reactance, although the circuit would offer high reactance to an alternating current. If the d-c is pulsating there is reactance to the pulsations, for they represent an a.c. superposed on the d.c.

A coil has positive reactance and it is directly proportional to the frequency. It is zero at zero frequency and infinite at infinite frequency. A condenser has negative reactance and it varies inversely as the frequency. It is infinite at zero frequency and zero at infinite frequency. If a coil and a condenser are connected in series in a circuit, there is one frequency at which the coil reactance is equal, numerically, to the condenser reactance. At this frequency the two reactances cancel each other, and the result is resonance. When that occurs the only impedance in the circuit is resistance, that is, electrical friction. It is only the friction which limits the current that results from a finite electro-motive force.

(Continued on next page)



# A Slide-Back Type Vacuum Tube Voltmeter

By John C. H. Worcester

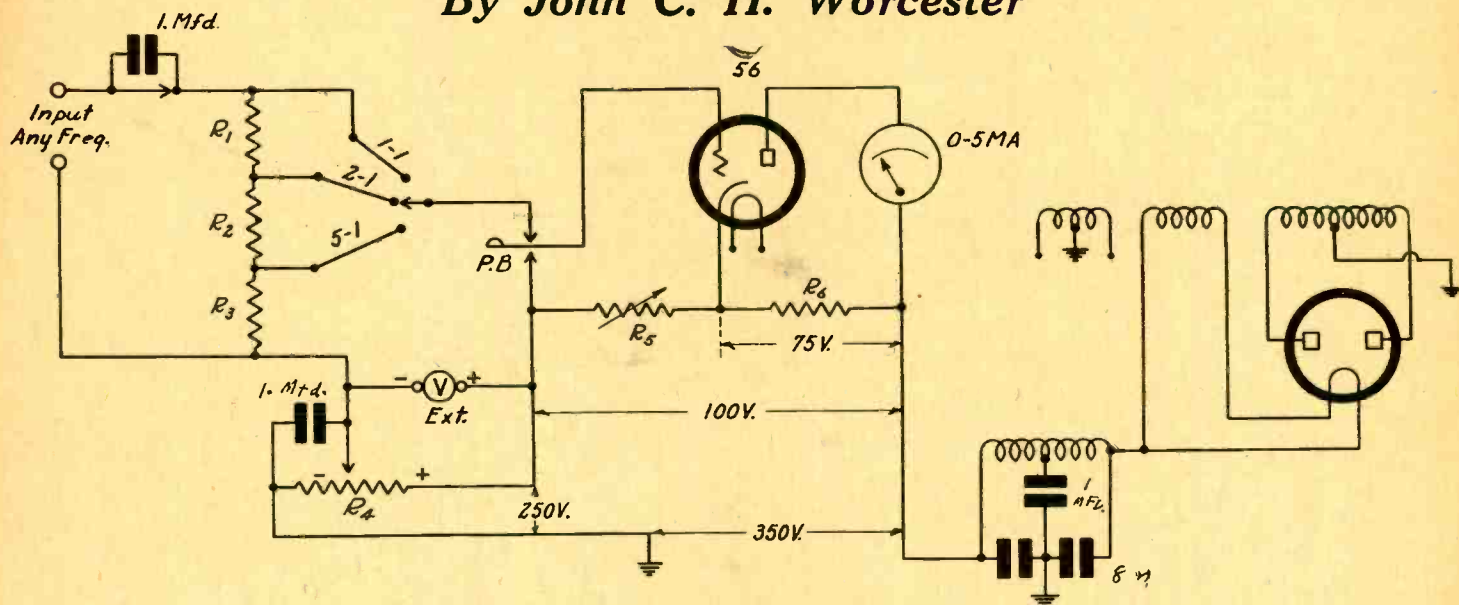

FIG. 1

The circuit of a slide-back vacuum-tube voltmeter with its own power supply. Voltages are measured in terms of the drop across a potentiometer.

A SLIDE-BACK vacuum-tube voltmeter is a handy device to have around the radio laboratory. A device of this kind to be real handy should have its own B supply so that to get it ready for use all that is necessary is to plug in the cord into the nearest outlet. When the circuit is arranged in that manner the vacuum tube voltmeter becomes just as convenient as any other voltmeter.

There are several types of vacuum tube voltmeter. One is the so-called slide-back meter, which measures peaks of alternating voltages and as well as d-c voltages. Another type is the direct reading instrument, which may be calibrated either to read r.m.s. alternating voltages or peak values. Then we may have current-drawing instruments as well as non-current drawing meters. For precise work, the meter should be non-current drawing. However, for practical purposes it is all right to permit some current to flow, provided this current is very small. It is only when measuring the voltage across highly selective circuits that small currents affect the voltage measured. This does not apply to oscillators, that is, to measurement of voltages across oscillator tuners. There may be a high voltage across the circuit notwithstanding that there is a comparatively low resistance in parallel with. Therefore if a very high resistance is added in parallel with the resistance already across the circuit, the voltage will not be changed appreciably. But when the voltage is measured across a passive circuit, such as a resonator used in a receiver, even a small current through a shunt resistance might change the voltage considerably.

## The Slide-Back Meter

In Fig. 1 we have a convenient slide-back vacuum-tube volt-

meter designed and built by Alan Mannion. For rectifier a 280 is used and this is fed by the usual power transformer. Also, the usual B supply filter is provided. This part of the circuit is of no particular interest just so it is present in the device and supplies the required filtered voltages.

The vacuum tube employed in the voltmeter is a 56. It has a fixed, or nearly fixed, plate voltage of 75 volts, determined by resistance R6, which should have a value of 7,500 ohms. In the grid circuit is a variable resistance R5 of 2,500 ohms which serves to provide an adjustable grid bias. The maximum drop in this resistance is 25 volts, which biases the tube nearly to the cut-off point.

In series with the voltage divider R5, R6 is a 25,000-ohm potentiometer R4. The maximum drop in this will be 250 volts, and this is the limit of the voltages that can be measured with the instrument without resorting to accessories.

## Manipulation of Circuit

In the grid circuit of the 56 is a press-button switch P.B. When this is pressed down the unknown voltage is removed from the grid circuit and the bias provided by R5 alone is on the grid. With the button down R5 is adjusted until the milliammeter in the plate circuit reads some low value—the lowest that can be read with certainty and a value that can be duplicated with precision. That is, a division point on the scale should be selected.

When the press-button switch is released, an additional voltage is impressed on the grid, assuming that the switch across the grid condenser is closed. The value of the added voltage depends on the setting of the slider on R4 and also on what

## Definitions of Recurrent Terms

(Continued from preceding page)

Susceptance.—The susceptance is the reciprocal of the reactance. Therefore the susceptance of a condenser varies directly as the frequency and the susceptance of a coil varies inversely as the frequency.

### Magnetic Ideas

Magneto-motive force.—When a current flows through a wire wound around an iron core, the core is magnetized, and the magnetization depends on the intensity of the current. The force that produces the magnetic flux in the core is called magneto-motive. The power engineer speaks of magneto-motive force as ampere-turns.

Magnetic flux corresponds to current. Reluctance is the resistance equivalent, that is, reluctance opposes the flow of magnetism. The relation among magneto-motive force, magnetic flux, and reluctance is the same as that among electro-motive force, current,

and resistance. It is an Ohm's law for magnetic circuits.

Permeability.—Some materials, especially those containing iron, nickel, and cobalt, are more easily magnetized than other materials. That is, for a given magneto-motive force a greater flux will result. The reluctance of the magnetic circuit is lower by a certain factor when the core consists of one of these magnetic materials. This factor is the permeability of the substance. If the reluctance of a magnetic circuit is R when the coil is wound on air, it becomes  $R/\mu$  when the entire core is made of a material having a permeability  $\mu$ . The permeability for any given magnetic material is not a constant, but depends on the flux. If there is an air gap in the magnetic circuit, this gap reduces the effective permeability of the circuit for even a short gap will have a very high reluctance compared with the reluctance of the magnetic material, especially if that material is soft iron and certain alloys of iron and nickel, the so-called permalloys.



- One power transformer
- Two 30-henry chokes
- Two 1 mfd. bypass condensers
- One 4 mfd. bypass condenser (slider to ground)
- Two 8 mfd. electrolytic condensers
- R1 — One 1-meg. resistor (1 per cent. accuracy)
- R2 — One 0.6 meg. resistor (1 per cent. accuracy)
- R3 — One 0.4-meg. resistor (1 per cent. accuracy)
- R4 — One 25,000-ohm potentiometer with knob
- R5 — One 2,500-ohm variable resistor
- R6 — One 7,500-ohm, one-watt resistor
- One five-contact socket
- One four-contact socket
- One press-button switch
- One single-pole, double-throw switch
- One three-point, single-pole switch
- One line cord
- Four binding posts
- One 0.5 (or more sensitive) milliammeter
- One voltmeter (external or built in)

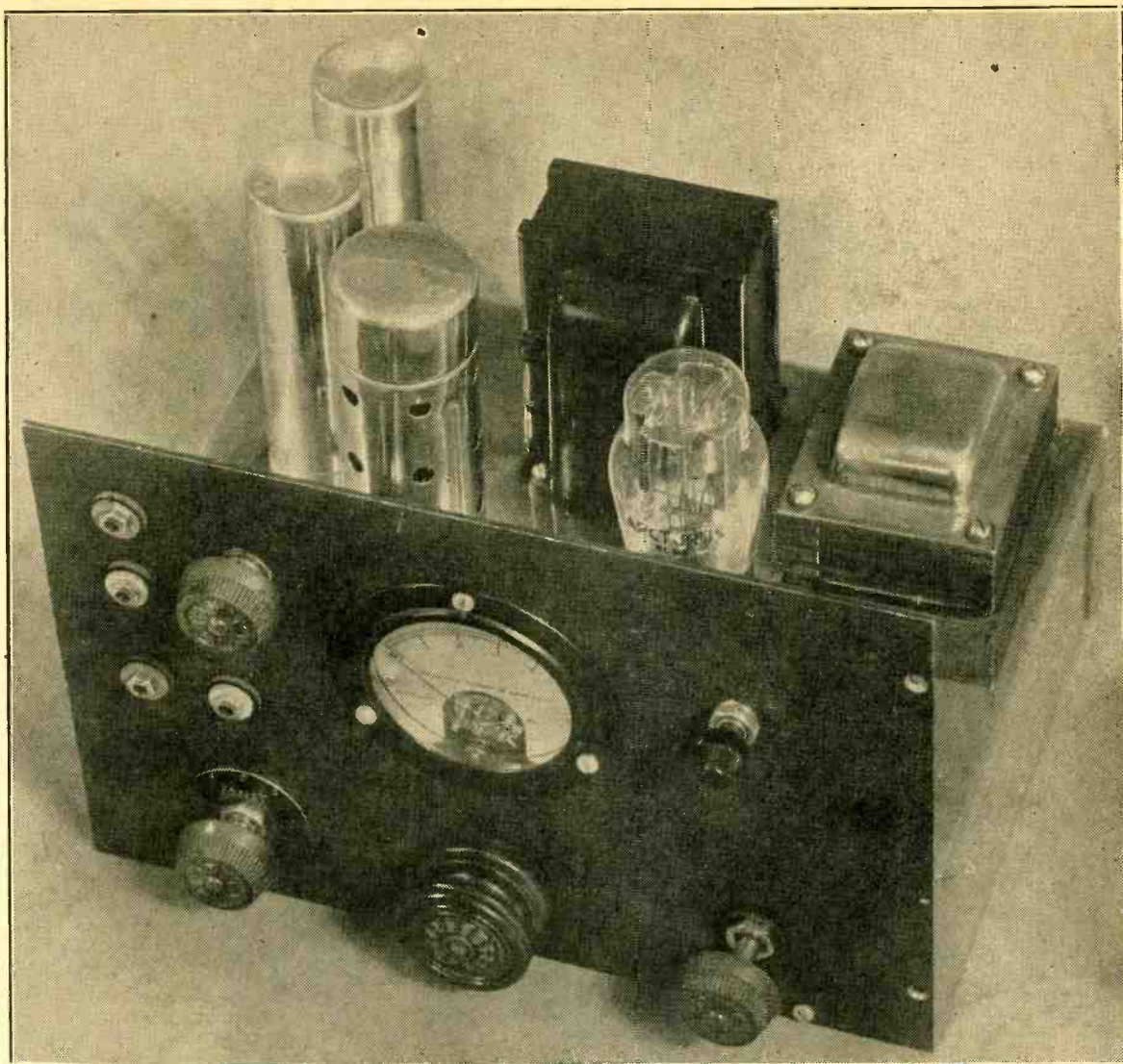

**FIG. 2**  
**Front — top slide — back vacuum-tube voltmeter, showing the layout of the parts.**

voltage is applied across the input terminals. With the switch across the grid condenser closed, the circuit is ready for measuring d-c voltages. If a d-c voltage is impressed across the input terminals, the negative should be connected to the negative end of R4 and the positive should be connected toward the grid. The slider on the potentiometer is now adjusted until the plate milliammeter reads the same as it did when the press-button switch was closed. The value of the voltage impressed across the input terminals is now read on the voltmeter V, which in the circuit built up was external but may be incorporated with the rest of the instrument. Before accepting the reading as final, the index plate current should be checked by pressing the button P.B. again. If the plate current is not the same as it was the first time, R5 should be readjusted first and then R4. A difference between the readings is not likely to occur unless it took considerable time to make the first adjustment.

**Measuring A-C Voltages**

We said that the circuit was in readiness for measuring d-c voltages. It is also ready for measuring alternating voltages. But when such voltages are measured, it is preferable to make the index current as read by the plate circuit milliammeter be as small as possible. If this is chosen practically zero, the d-c milliammeter will measure the peak of the input voltage.

The function of the 1 mfd. stopping condenser in the grid circuit is to permit measurement of alternating voltages when the source also contains direct voltages. Suppose we wish to measure the alternating voltage across a plate coupling resistance. There is a strong d-c component in this and if the resistor were connected across the input terminals, the resulting reading would be the maximum voltage, that is, the d-c component plus the amplitude of the a.c. We only want the amplitude of the a-c voltage. Therefore the switch short the condenser is opened, putting the condenser in series with the circuit and thus stopping the d-c. The condenser is so large that it will not appreciably change the alternating voltage even at the lowest frequency at which a measurement may be made.

**Voltage Extension**

We stated that the limit of voltage measurement was 250 volts, the maximum drop in R4. That is true only when the one-to-one ratio is used. There is a voltage divider connected across the input terminals consisting of R1, a one-megohm re-

sistance, R2, a 0.6-megohm resistance, and R3, a 0.4-megohm resistance. Therefore there is a total of 2 megohms across the terminals. When the switch is set so as to pick up (1-1), the limit is 250 volts. When it is set on the next point only one half of the total voltage applied is measured, and therefore the limit is raised to 500 volts. When it is set on the last step, only 1/5 of the voltage impressed is measured. Hence the limit is 1,250 volts.

The lower voltage limit in any case is determined by the meter V. If a voltage of one volt can be read accurately on this meter, that might be said to be the limit, unless, of course, a still lower voltage can be read accurately. There is no objection to having a multi-range voltmeter in this position, and it really should be used if accurate determination of both low and high voltages are to be made.

The voltage divider used for extending the range of the meter draws current and for that reason the measured voltage will always be slightly less than the voltage existing across the device before the voltmeters is connected. However, as was stated, this has not practical significance except when the voltage across the tuned circuit not a part of an oscillator is measured. And even when this is done, there is little drop in voltage when a 2-megohm resistor is connected across the circuit. In other words, even in cases of highly resonant circuit, a very good approximation to the true voltage can be obtained.

**Connection of Ground**

While there is a ground symbol in the vacuum-tube circuit, this does not mean an external ground, or the ground in the receiver or circuit under measurement. It simply means the chassis of the voltmeter. If the voltmeter and the receiver are connected many measurements cannot be made. Hence the two should be insulated from each other except at the two input posts.

As indicated on the drawing, the milliammeter in the plate circuit of the 56 is a 0.5 milliamper meter. But its range is of little importance, except that it should not be much less sensitive, for it is important in making a-c measurements with the slide back method that the minimum current be low. A low current is more easily read and duplicated with a sensitive milliammeter than with a meter of, say, 0-10 range. If a more sensitive meter be used, there should be a suitable resistance in series with it as a matter of protection.



# A Neon Audio Oscillator

## Connections for Modulating an R-F Oscillator

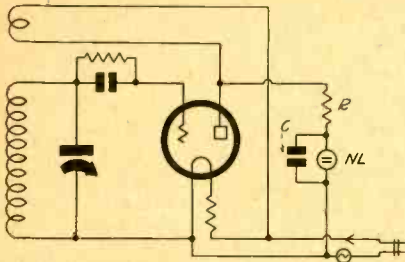

A neon oscillator modulating an r-f oscillator, by connection of the neon circuit to the grid of the triode.

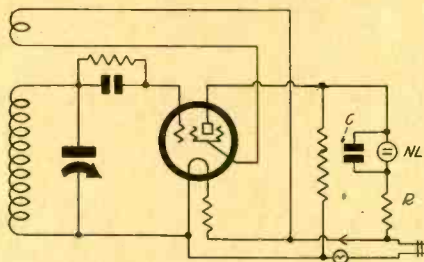

In this circuit the connection from the neon oscillator circuit is made to the plate of the triode.

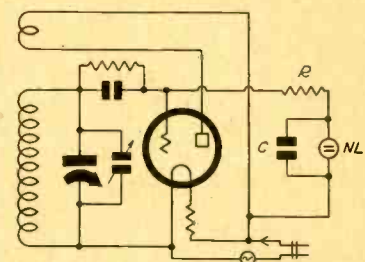

Here the modulating frequency is unaffected by tuning and modulation is always present.

THE neon tube as an audio oscillator serves admirably the purposes of modulation in a test oscillator. That object is fully achieved even with the smallest-powered neon lamp commercially made, a small fraction of a watt. The oscillation intensity is sufficient, there is no danger of overmodulation if the correct connections are made to the radio-frequency oscillator, and the nuisance of having a high-resistance leak as a blocking device to cause the r-f oscillator also to generate audio frequencies is avoided.

The introduction of a separate modulator tube is advantageous because then the selectivity may be practically uniform over the tuning range or ranges, and zero beating always is possible. While the actual value of zero beating may be small, especially to those who use the modulated oscillator to measure and peak r-f and i-f channels, nevertheless the fact that it can zero beat at all and any settings is a compliment to the oscillator. It means that the damping is not so high as to drown the zero beat, which is actually present though not heard.

### How Shall Introduction Be Made?

While zero beating is mentioned, all audio beating is really meant, for when the circuit is properly proportioned there will be audio frequencies heard when the test oscillator is worked in conjunction with a receiver which is bringing in a broadcasting station, whether beating is with the carrier of the station itself, the local oscillator or with the intermediate frequency, which is also an oscillating frequency, although not particularly so regarded by many.

The problem is to introduce the modulation from the neon lamp in such a manner as to avoid over-modulation, avoid absence of audio oscillation, avoid detuning effects on the tuned circuit, and avoid the tuning condenser changing the pitch of the audio oscillation.

But before there is any trouble of this type first there must be audio oscillation so let us state that values will produce it nicely.

The neon tube will strike at around 76 volts or so, and any voltage applied in excess of this simply produces more glow, greater current through the lamp and small frequency change! However, the oscillation is present by virtue of the interruption of the current flow, and there must be a charging current which does not exceed the minimum discharge current. Various combinations will effectuate this, but then the frequencies of oscillation will differ. For instance, the frequency may be as low as 1 cycle per second, which is entirely too low for modulating purposes. The frequency may be raised either by raising the series resistor or decreasing the capacity across the lamp.

### Access to Lamp Itself

Many of the lamps now used have a series resistor built in, around 100,000 ohms, hence access to the lamp terminals proper is not possible, without removing the resistor. If a condenser is put across the base into which the lamp fits, the condenser will be across the series circuit consisting of the neon lamp and the limiting resistor. Audio oscillation may not be reliable under

such circumstances. It may be present at times, but the audio oscillation may not be always self-starting. However, small devices using pigtail lamps about as long as a thumbnail may be taken apart, particularly a neon-equipped fuse, and the small lamp's resistor removed. Then a condenser of 0.00039 mfd. is put across the lamp, and a limiting resistor of 4.0 meg. is used. The audio frequency thus generated will be around 3,000 cycles, and makes a nice-sounding and distinctive note, which one appreciates for modulation purposes. Moreover, the oscillation intensity of the neon lamp has a steady average that enables output meter readings being taken without confusion due to jumpiness of the needle. The grid-blocking method, that is, high resistance in the leak-condenser circuit of the r-f oscillator, produces decidedly wobbly output.

### The Shifting Spot

With the constants properly chosen, R being 4.0 meg. in the diagrams, and C being 0.00039 mfd., the neon lamp may be of any wattage. The oscillation amplitude will depend on the difference between the striking and the extinguishing voltages, hence partly on the amount of the voltage applied for any given value of R. However, if not enough is applied, there will be no striking. The resistance of 4.0 meg. is suitable for voltages around 100 volts.

If the tube glows brightly it will not oscillate at an audio frequency, that is, the limiting resistor is entirely too low or voltage applied is too high. Usually the glow concentrates in one corner as a sort of spot, when audio frequency oscillation occurs, although as the capacity or resistance is changed, the spot travels in a spiral course. This denotes a phase shift and might be used by the ingenious experimenter for phase-angle displacement measurement.

It is confessedly hard to find a suitable method of connection for the lamp, especially if a triode is used. If the total voltage available is something around 100 volts, as from the line in a universal type test oscillator, then if the method shown at left is used there will be too high a direct-current voltage on the grid during the conducting period in the neon circuit, and indeed this voltage is itself fluctuating at the audio frequency of oscillation, and produces an unsteadiness.

### Use With a 34 Tube

If the connection is made to the plate from the other side of the line, as in the central diagram, then too much capacity is introduced in the plate circuit, where it is even more serious than its identical quantity in the preceding example of the grid circuit, because in the plate circuit it might stop oscillation at all radio and certain audio frequencies, or may start parasitic oscillations, with confounding results.

The best method found for a universal test oscillator is that used in the commercial model 30-AB, and is diagramed at right. Here the control grid of a 34 tube is used in the familiar fashion, the screen is used as the effective plate, for feedback, and the erstwhile plate is connected through a low resistance to the negative side of the line. It is called negative because when a.c.

(Continued on page 20)

J. B. Bryson, 924 - 7th St., West, Birmingham, Ala.  
Walter J. Tyczka, 814 Clinton St., Buffalo, N. Y.  
George Gasoarini, 1436 Hollywood Ave., Chicago, Ill.

Edward Choy, 801 - 18th St., Bakersfield, Calif.  
Sanger Radio, A. D. S. Goldsman, Mossbury Works, Mossbury Road, Clapham Junction, London, S.W. 11, England.

Victor De Ziel, 170 Lafond Street, St. Paul, Minn.  
Peter Lorino, Lorino Radio Co., 36 Lindsey Court, Hialeah, Fla.

Don Seliga, 250 North Heights, Youngstown, Ohio.  
John Jarrett, 222 High Street, Lowell, Mass.  
Geo. B. Thompson, M.D., 2400 West Pico Street, Los Angeles, Calif.

G. R. Hill, Radios and Radio Repairing, Route 1, Galva, Kans.

### Literature Wanted

Readers desiring radio literature from manufacturers and jobbers should send a request for publication of their name and address. Address Literature Editor, RADIO WORLD, 145 West 45th Street, New York, N. Y.

Otto Krause, 59 W. Forest Ave., Detroit, Mich.  
Robert F. Graham, 1461 Carmen Ave., Chicago, Ill.

Elton M. Shuman, 89 Western Avenue, Waterville, Maine.

Russell Roach, Absaraka, No. Dak.  
Jose de Paz, Hudson Radio Store, 531 West 145th St., New York, N. Y.

F. R. Bryant, 3948 West End Ave., Chicago, Ill.  
H. R. Hanson, 701 Bradley St., St. Paul, Minn.

Pvt. Luther D. Wilkerson, Veterinary Station Detachment, Fort Sam Houston, San Antonio, Texas.

R. W. Stupp, 231 Hummel Ave., Lemoyne, Penna.  
S. D. Eilenberg, 14 Reeser Ct., Phillipsburg, N. J.  
L. H. Veach, c/o Sou. R.R., Union Station, Columbia, S. C.

R. L. Stitzel, 529 N. Sunnyside Ave., South Bend, Ind.



# Remedies for Motorboating Two B Supplies and Individual Filtering of Circuits Are Aids

By Finar Andrews

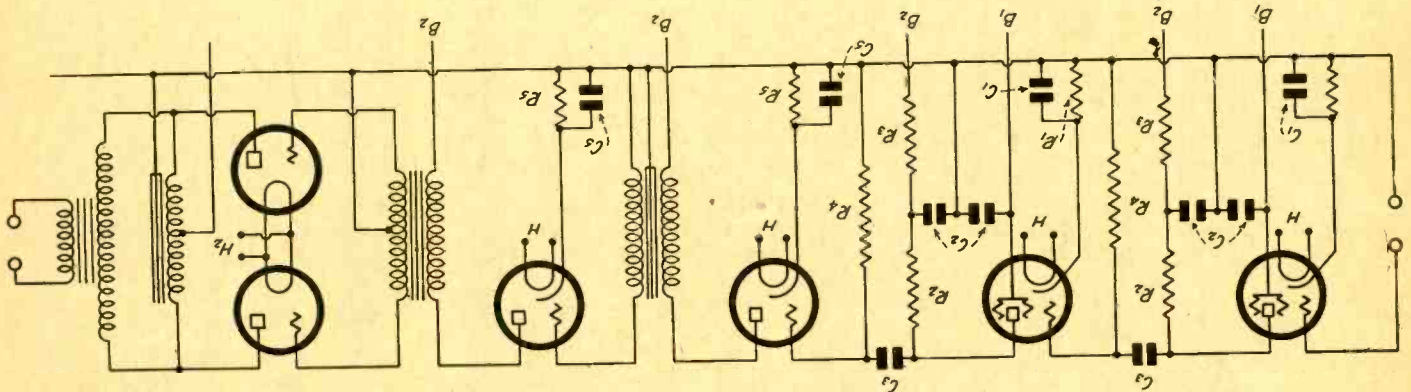

FIG. 1

This is a skeleton form of a five-stage, six-tube, high-gain audio amplifier which illustrates how motorboating occurs in a sensitive amplifier. Two separate B supplies are suggested to stop oscillation.

**MOTORBOATING** is loose again. For a while we did not have much trouble with it because audio amplifiers used in receivers did not have much gain, or only two stages were used, one of which was resistance coupled. But high-gain amplifiers for public address purposes and other applications are being constructed, amplifiers having as many as five stages. Motorboating is an almost unavoidable consequence of multiplying the number of stages in the amplifier. Let us review the subject in connection with a five-stage amplifier. It might be well to say that we are not describing an amplifier to be built.

The first two tubes in the circuit are screen grid tubes in resistance capacity settings. They are capable of high gain and for that reason motorboating is likely to be encountered in the circuit. In a certain amplifier built along this line violent motorboating occurred when the first tube was in the socket without anything connected across the input terminals. When the terminals were shorted, the difficulty was intensified. When a high negative bias was applied to the grid of the first tube, the trouble stopped.

## The Way of Feedback

These facts point to the way in which the feedback occurs. When the tube is out of the socket there is no conductive path to ground through R2. Therefore any signal voltage existing across the B supply terminals (B2 and ground) will send a current through R2. This will affect the voltage across the grid resistance R4 and the voltage across this resistance due to the feedback will be amplified by the succeeding tubes. It only requires an infinitesimal amount of feedback to cause sustained oscillation when there is so much amplification as in this circuit. With tube out of the socket current can flow through R2 but only through C3 and R4. The feedback current through the grid leak will now be out of phase and it will not build up by continued regeneration. The same thing happens when the grid of the first tube is given a high negative bias, for then the plate current in that tube is cut off, and if any feedback current is to flow through R2 it must first go through C3 and then down to ground through R4. That is, when there is a conductive path through the tube there will be a voltage fluctuation across R2 due to the feedback and this will be in correct phase for oscillation, but when the first tube is open for any reason no in-phase feedback can occur.

## First Part Unstable

If we consider only the first three tubes in the amplifier, including the plate circuit of the third tube, we have an unstable amplifier. It is so unstable that it is practically impossible to stop motorboating. This is especially true when the first two tubes have a high gain.

If we consider only that part of the circuit which contains the two low- $\mu$  tubes, that is, the two in the plate circuits of which are primaries of transformers, we have a possible motorboating amplifier. But oscillation in this part of the circuit is not like usual. Signal current re-suits from audio voltages across the B supply will back up through the first transformer primary and through the third tube.

## Standard Remedies

The standard remedy for motorboating is to filter the individual plate circuits. This is indicated in the plate circuits of the first two tubes. A resistor R3 is connected in series with each coupling resistor R2 between the junction and the B supply. Then a condenser C2 is connected between the junction and ground. Unfortunately these filters are not effective in all instances, and in this particular case they had no noticeable effect. The gain in the tubes was too high. Of course, it is theoretically possible to use condensers large enough to make the filter effective at even the lowest audio frequency, but when the gain is high, the values of capacity required are so high that it is practically impossible to provide them.

The two filter resistors could be replaced by chokes, and they would be much more effective at the higher frequencies, but it is rarely at the high frequencies that the trouble occurs, for at these it is effectively prevented by the condensers in the B supply filter. When the power stage contributes much of the feedback, and it is always safe to say that it does, some improvement results when the circuit is connected as in this diagram. The plates are fed through high inductance chokes and the primary of the output transformer is connected between the two plates. If there is no ground connection to the primary no stopping condensers are needed. This is advantageous for the low audio frequencies can circulate through the winding without causing any feedback. When the middle of the primary is grounded stopping condensers are needed and when they are used they should be large. Large capacity is not needed so much to insure good quality as to prevent feedback. It is only the feedback that goes through the plate chokes to be B supply that causes any trouble. These are standard remedies, which are no remedies at all in a circuit as sensitive as this one is. A few tests on the circuit made this clear.

## Treatment of Power Stage

When the power stage contributes much of the feedback, and it is always safe to say that it does, some improvement results when the circuit is connected as in this diagram. The plates are fed through high inductance chokes and the primary of the output transformer is connected between the two plates. If there is no ground connection to the primary no stopping condensers are needed. This is advantageous for the low audio frequencies can circulate through the winding without causing any feedback. When the middle of the primary is grounded stopping condensers are needed and when they are used they should be large. Large capacity is not needed so much to insure good quality as to prevent feedback. It is only the feedback that goes through the plate chokes to be B supply that causes any trouble. These are standard remedies, which are no remedies at all in a circuit as sensitive as this one is. A few tests on the circuit made this clear.

## Other Remedies

If filtering will not stop motorboating in a circuit, is it necessary then to avoid high-gain audio amplifiers or are there other means for stopping the trouble? If the difficulty occurs at a very low audio frequency, there is a very simple remedy, and it is about the only one that is effective, for chokes and resistance in the B supply on the plate there is conduction only when the plate is positive. (Continued on next page)



# Radio University

Answers to Questions of General Interest to Readers. Only Selected Questions are Answered and Only by Publication in These Columns. No Correspondence Can be Undertaken.

resistance coupled tubes of high gain when they are placed next

## Altering Frequency Changer

CAN A FREQUENCY CHANGER consisting of an intermediate transformer and a radio-frequency transformer and designed for use with a 57 or a 24 be used in conjunction with a 2A7?

The condenser will have to be made if it is practical?—G. F.

now connected to a tap on the oscillator coil. Remove it and make two independent transformers. Bring out the eight leads separately. After that has been done the two transformers can be used in any circuit.

## Effect of Transposition

JUST HOW does transposition of conductors in a lead-in suppress noise? I must say that I have tried transposition without any appreciable improvement in the signal-to-noise ratio.—F. G. K.

The transposed lead-in does not help against noise that is picked up by the antenna. It only prevents additional pick-up in the lead-in. Suppose that in order to get a good signal pick-up you have to run a long lead-in past several floors where there are many electrical appliances. All of these appliances are noise transmitters. Not much of the noise gets up to the antenna but considerable of it gets to the lead-in. Hence if the lead-in is transposed at frequent intervals, the net pick-up by that lead-in is practically zero. If the noise originates at a point a long distance away from the antenna that is used, assuming that it is not sharply directional.

## Microphones

WHAT is the difference between a pressure and a velocity microphone? What pressure and what velocity are involved? In what respect is one superior to the other?—R. H. T.

The pressure and velocity are those of the air due to the passage of a sound wave. There is always a certain barometric pressure. As a sound wave passes there is a change in this pressure. One moment it is higher than the barometric pressure, the next moment it is lower than that pressure. The pressure microphone responds to the variation. Since there is a change in the air pressure, there is also a flow of air from one point to another, a back and forth flow. The rate at which an air particle moves is the velocity. It really amounts to a wind, but instead of direction it is alternating. The velocity microphone responds to the movement of the air, which means that the responsive element in the microphone must move with the air. The responsive element in a pressure microphone should not move. Yet it is necessary that it move in order that there be any effective. The case is similar to a voltmeter and a current meter. The voltmeter is pressure responsive whereas the current meter is velocity responsive, for voltage is electrical pressure and current is electrical velocity. Ordinary direct-reading

(Continued on next page)

# Neon Tube Coupling to R-F Oscillator

tion, nor is the frequency of audio oscillation shifted by the rotation of the r-f tuning condenser, because the two oscillators separated by the equivalent high resistance than that, since only a tiny part of the stream runs through this resistor. Considerable experimenting was done with the model that incorporates the neon tube, using the values specified, and the results were so completely satisfactory that they made possible the improvement of the accuracy of the oscillator, besides adding the undeniably advantageous of an attenuator, provided the line was blocked. The total circuit of the Model 30-AB Test Oscillator has been tested and drawn up, with the expectation that it will be printed in next week's issue, so that the method of line-blocking, and other interesting facts, will be presented. Also a picture-diagram of the wink is in preparation and it is hoped this will be ready in a month. At least, it is being prepared for publication, and those interested in test oscillators, especially of the frequency-stabilized type (meaning highly accurate models will want to follow this circuit, which they can build themselves, if they so desire.—Herman Bernard.

line is negative in respect to plate. There is current through this low resistance, even though the element, the conventional plate, is seemingly grounded. The current flow is due of course to the existence of a potential difference across the resistor from plate to line. The plate is associated with the space stream inside the tube and catches some electrons to return them to cathode through this resistor. That they are few is proved by the fact that the voltage drop across this resistance is not sufficient to lower the effective voltage on the neon lamp to that point where oscillation stops. If the plate were connected to the positive side of the line the neon tube would neither oscillate nor light, because of too much drop in this resistance. Say 10,000 ohms are used. At 5 milliamperes the drop would be 50 volts, and this would be enough to prevent oscillation. In practice the resistance from plate to negative line is 10,000 ohms, and it is a potentiometer, so that the output is varied by moving the slider. The frequency generated by the r-f oscillator is not changed, especially as the coupling is electric, and during alteration the side called negative of the

(Continued from page 18)

A heavy-duty B supply, of course, is needed for the transformer primary would be suitable in that case. Sometimes motorboating is eliminated by using separate voltage dividers for the different tubes in the circuit. But this is no more effective than the method of using individual filters, for the two are identical, except that when individual voltage dividers are used there is a bleeder for each tube as well as a series resistor or choke. It may be that if separate filters in the B supply are used greater stability will result. But this, too, is equivalent to using individual filters using larger chokes and larger condensers. If this is done and the rectifier employed has a constant voltage drop across it, there should be complete stability. The simplest way of attaining stability, it appears, is to use a separate power supply for a couple of the tubes, especially two

Should the plate return of the third tube be connected to the same in B supply, it would be very difficult to stop motorboating. Hence that should be connected to the supply of the remaining tubes. Stabilization of the transformer coupled circuit is comparatively easy. Since the auxiliary B supply serves only two tubes, and the total current drawn by these tubes is very small, it requires only a small rectifier and small filter chokes. Even the capacitors in the filter can be comparatively small. For a rectifier a general purpose tube like the 56 could be used. For a transformer any small power transformer giving a rather high voltage should be employed. For chokes, the secondary or primary windings of an audio transformer would be all right. However, whether these would be suitable would depend on the total current they are required to pass. There may be a bleeder current in the voltage divider that draws as much as the two tubes together. But even so, the total current need not exceed 5 milliamperes. Almost any audio transformer

resistance-coupled amplifier is stable. If a separate B supply is used for the first two tubes, the series resistors R3 are not needed. Neither are the by-pass condensers C2, for there will be sufficient by-pass capacity in the B supply filter. Should the plate return of the third tube be connected to the same in B supply, it would be very difficult to stop motorboating. Hence that should be connected to the supply of the remaining tubes. Stabilization of the transformer coupled circuit is comparatively easy.

In severe cases of motorboating the only practical way of stopping the trouble is to use separate B supplies for the different parts of the circuit. This does not mean, of course, that there should be one for each tube in the circuit. That would hardly be practical, even though it is desirable. But can use two B supplies to good advantage. One should serve the first two tubes in the circuit, meaning the circuit in Fig. 1 or one like it. There can be no motorboating in this part of the circuit if that is done, for a two-stage resistance-coupled amplifier is stable.

It is or not cannot be determined except by experiment. The gain on the low notes is as high as it ought to be. Whether motorboating frequencies. By just stopping the oscillation it is possible gain at that frequency is excessive and it is also high on neighboring frequencies. This reduction does not necessarily introduce a great deal of distortion, for if the circuit motorboats on a low frequency, the gain at that frequency is as high as it ought to be. Whether motorboating frequencies. By just stopping the oscillation it is possible gain at that frequency is excessive and it is also high on neighboring frequencies. This reduction does not necessarily introduce a great deal of distortion, for if the circuit motorboats on a low frequency, the gain at that frequency is as high as it ought to be. Whether

What do these condensers do? First they stop the d-c from going on to the grid, and second they stop the low frequencies. The lower frequency the more effective is a condenser in stopping the signal, and the smaller the condenser, for a given frequency, the more effective it is in stopping the signal. Therefore if the oscillation occurs on a very low frequency, reducing the size of the stopping condensers will stop the trouble. Reducing the size of the condensers naturally introduces frequency distortion, for they will reduce the gain not on one frequency but on all. The reduction is only greater at the lower frequencies. The cut-off is rather sharp so that if the oscillation occurs at a frequency of, say 5 cycles per second, there need not be much reduction of the amplification on the essential audio frequencies, say those in excess of 25 cycles per second. This reduction does not necessarily introduce a great deal of distortion, for if the circuit motorboats on a low frequency, the gain at that frequency is as high as it ought to be. Whether

(Continued from preceding page)



(Continued from preceding page)

volmeters must draw some current. The best voltmeter draws no current and then it is a true pressure-operated device. The velocity microphone has the advantage that it is practically independent of the frequency and one of its disadvantages is that it is not nearly as sensitive as some pressure-operated microphones. But the pressure-operated microphones are not independent of the frequency.

### Class B Amplification

WHEREIN does Class B amplification differ from push-pull amplification? It seems to me that the circuits for the two are identical. There must be some distinguishing feature that characterizes each type of amplifier.—T.R.M.  
In Class A push-pull, both tubes work all the type but in opposite phase, one relaxing while the other takes hold. The grids of the two tubes must be biased so that the plate current in each tube can increase as well as decrease, by about the same amount, and so that at no signal both draw about the same plate current. In Class B, on the other hand, only one tube works at a time. One tube handles one side of the signal and the other tube the other side. Each of the tubes in a Class B amplifier is a grid bias detector biased to the cut-off or very near that point. The output consists of two current pulses per cycle. These are combined in the output transformer so as to produce a regular wave. In the Class B amplifier no plate current flows in either tube when there is no signal. It is for this reason that the Class B amplifier is much more efficient than the Class A.

### U. S. Standard Frequency

WHAT KIND of receiver is required for picking up the 5,000-cycle standard transmitted by the Bureau of Standards? How can it be identified? If this cannot be picked up, can the broadcast stations be relied on as standards of frequency?—W.E.J.  
Any short-wave receiver should be sensitive enough to pick up the Government transmission, provided that receiver reasonably sensitive. Get an approximate calibration of the receiver and then try to receive the standard frequency on the dial setting where it is supposed to come in. It will not be far off. Remember that the standard frequency is only on the air at certain times, Tuesdays from 12 noon to 2 p.m. and from 8 p.m. to 10 p.m. Announcements are made in code. Locate it by the approximate calibration and the time of day if you cannot read code. Broadcast stations can be relied on for all practical purpose of calibration, especially the larger stations below 1,000 kc. They are held very closely to the frequencies assigned them.

### Precision Voltmeter

RECENTLY I acquired a wall type galvanometer provided with a long scale and a telescope. It is extremely sensitive as I can detect current through 100 megohms. I have wondered if this galvanometer could not be used for a precision voltmeter, one that draws practically no current. If so, how can it be done?—W.E.C.  
Yes, it can be used as a voltmeter as well as a current meter. If you use it as a voltmeter it is necessary to calibrate it against known voltages, using series resistors that do not change with current or with temperature. You might calibrate it against a voltmeter that does draw current, for if the two are across the same voltage at the same time, the current drawn does not make any difference. The calibration will be no better than the accuracy of the instrument you use for calibrating against. Moreover, it is difficult to get good high resistances at reasonable cost. It is quite likely that the resistances will cost more than the galvanometer.

### Swamping Small Stations

WILL THERE not be danger of swamping all the small broadcast stations as well as some of the larger ones when the 500-kw station WLW gets going? This is a power ten times higher than any station now operating and even now some of the larger stations interfere with the small stations.—L.H.Y.  
It is only those who live close to the super-power stations that are likely to have much trouble of this nature. Experience has shown that increase of power does not greatly increase the interference range, although it does increase the reliable coverage range. This fact, of course, is directly due to the fact that modern receivers are extremely selective. A few years ago a 500-kw station would have blanketed nearly all other stations over a wide area and a wide frequency range. The station will never go on the air with 500 kilowatts if there is much interference from it. The Federal Radio Commission will see to that.

### Capacity and Inductance Measurements

AS I DESIRE to have some measuring equipment, not necessarily of the precision type, but good enough for a conscientious experimenter, what would you advise in respect to measurements of inductance and capacity?—R.W.  
It is highly advisable that you have a calibrated condenser. This type is usually of the straight line capacity type, so that equal differences on the dial always will represent equal differences in capacity. If you can not afford a calibrated condenser you could calibrate your own, using a 50 tube as oscillator, grid-leak fashion. With values of 500,000 ohms for series leak, 0.00005 mfd. for grid condenser, plate voltage around 100, and grid returned to cathode, a commercially-obtainable honeycomb coil, costing about 60 cents, denser, plate voltage around 100, and grid returned to cathode, a

### Oscillator Suppressor

THE GRID SUPPRESSOR has been used in the past for suppressing oscillations, but I find now that it is included also in oscillators, where, it would seem, oscillations should not be squealed. Please explain.—K.D.  
The reason for the grid suppressor in test oscillators, or local oscillators in superheterodynes, is to increase the capacity reactance at the higher frequencies, where otherwise the oscillation intensity would be too strong, because the coupling of tickler makes it so. If the coupling is made looser it may be too loose for the low frequencies. Therefore the coupling is selected for the low frequency value, and in the grid-leak type oscillator the result will be a uniform amplitude over most of the scale, until high frequencies of the tuning range are reached or approached, when the damping effect of the series resistor becomes strong. Thus the amplitude may be flattened, that is, the intensity of oscillation is uniform, which is desirable.

### Choice of Coupling Condenser

WHEN A STOPPING condenser is used in an audio-frequency circuit in series with a transformer winding for the purpose of keeping the d.c. out of that winding, what should its value be? Is it sufficient to use one of the order of 0.01 mfd. or should it be 100 times as large?—G. H. L.  
What size the condenser should depend first on the lowest frequency which that condenser is in series. Suppose the transformer winding has an impedance of 100,000 ohms at 50 cycles per second. At this frequency the condenser reactance should not be more than, say, 1 per cent. as large as the transformer winding impedance. This would require a condenser of 3.18 mfd. If the impedance of the transformer winding is less than the specified value the condenser would have to be larger in proportion. If it is not necessary to amplify the 50-cycle frequency to such a high degree, the condenser may be smaller. If the transformer delivers power to a loudspeaker or to a driver stage, the impedance will not be nearly as high as the transformer delivers power to a load. Otherwisewise, the low notes would suffer a great reduction in amplification.

### About a Cage Aerial

WHAT ADVANTAGE has a cage antenna over a straight wire antenna? If all the wires are joined at their ends, I cannot see how the length of this antenna becomes, say, 100 feet if five wires of 20 feet each are used. I have tried one of these cage antennas and find reception better at certain wavelengths but not the same at different wavelengths. Can you account for the above?—A. J. Vitale, East Rutherford, N. J.  
If each wire is 20 feet long, any number of equal wires connected in parallel will make a conductor 20 feet long. But five wires will have much less radio-frequency resistance than one wire of the same diameter. That is one advantage. The inductance of the antenna will also be different. If the individual wires are far enough apart, the inductance of the combination will be about one-fifth, since that is the law by which non-coupled inductances combine. This does not change the inductance of the lead-in of course. Another difference is that the capacity of the antenna will be increased in about the ratio of the increase in the number of the wires. This makes the current in the lead-in more nearly uniform, which is supposed to make the antenna a much better radiator. By reciprocity it would also make it a better receiver. Any antenna, of course, is best at one particular frequency. Changing from one to five wires would only change the frequency at which it is best.



# Station Sparks

## By Alice Remsen

**SOMEONE** we know has just dramatized a globe wanderer who is stuck in the wilds of Africa and who reaches his pal on Park Avenue through his short wave set. The pal gets the location of his friend, who is in a devil of a fix, and goes to Africa and—well, the plot is something of a secret and that's as far as we can go. We mention the matter merely to indicate that short waves influence the drama even as they influence the radio *etc.*

### SPRING CHANGES ON THE MICROPHONE

With the Spring come changes in radio schedules. Horlick's Adventures in Health, featuring Doctor Herman N. Bunderson, president of the Chicago Board of Health and nationally known public health authority, has started a new schedule, and will be heard only once a week, on Sundays at 9:45 p.m., NBC-WJZ net work. Several new programs have opened over NBC. Lulu Vollmer, whose "Moonshine and Honey-suckle" series was such a favorite for two years, is back again with a new series called "Grits and Gray." Robert Strauss, a native of the Tennessee mountains, will have the leading role of Cade Crump, a happy-go-lucky mountaineer who gets the call to be a preacher. Antony Stanford will direct this series which will be heard each Thursday at 8:00 p.m. The new Terraplane half-hour program features Conrad Thibault, noted baritone, Louis Ben-net, popular soprano, and Harry Sailer's orchestra and choir, each Tuesday night over WJZ, 8:30 p.m. Clara, Lu and Em, have changed networks. They are now heard over WEAF and the red network, every week-day except Saturday at 10:15 a.m. "Castles in the Air," written, directed and played in by "young truly," has also switched networks, and may now be heard each Tuesday and Thursday morning at 10:15 a.m. on an NBC-WJZ network.

### AL JOLSON, BABE RUTH AND OTHERS

Al Jolson is busy writing his autobiography. Alice Joy has returned to NBC microphones in Chicago, after a series of personal appearances. Alice will be heard each Monday at 4:15 p.m. with Harry Kogen's orchestra, over an NBC-WJZ net-work. Irene Rich, heard over NBC on the Welch's Grape Juice program, is looking for a new play in which to return to the speaking stage. Babe Ruth is the newest star for radio. He opens for Quaker Oats, over WJZ on April 16th, at 8:45 p.m., and each Monday, Wednesday and Friday thereafter at the same time. Gene and Glenn have postponed their opening, in order to double the network over which they will be heard. The final date is April 23rd, every week-day evening except Saturday, at 7:15 p.m., over a nation-wide network. They will repeat the program for the Western half of the country at 11:15 p.m. Another new NBC series is a dramatic history of the United States, each Sunday at 4:00 p.m., under the sponsorship of the American Meat Packers, with the rather blatant title, "Romance of Meat." Robert E. MacAlarney, former managing editor of the *Ladies Home Journal*, will write and direct the new air series, and a cast of veteran radio performers will enact the events. Frank Parker was to have joined Benny on the new General Tire program, but I understand that the Cities Service raised his salary in order to keep him on their program, and so the General Tire will have to do without their little Frankie. Carolyn Rich, blonde songstress, opened on a new NBC sustaining series with Johnny Russell, one of The Sizzlers, on April 3rd; each Tuesday at 7:30 p.m. over an NBC-WEAF network.

### A CASE OF HARD-BOILED

The Don Hall Trio, early morning serenade over NBC networks, ruined a lot of perfectly good breakfasts the other morning, simply because they changed their routine. Their first song is usually timed three or three and half minutes. One day, recently, their first number ran a minute and a half longer than usual. The net day their mail contained over twenty letters complaining from their listeners had to eat hard-boiled eggs, all on account of the trio—this particular set of listeners had formed the habit of timing eggs by that first song each morning!

The worst has happened! Phil Baker has turned author. He has written a volume called "Wit and Witles" under the pen name of Eugene O'Baker. He gives

### CO-OPERATING WITH NEWSPAPER WOMEN'S CLUB

Both the Columbia and National networks, and WOR are cooperating with the New York Newspaper Women's Club, in publicizing the Front Page Ball to be held at the Hotel Astor on Friday, April 13th, for the benefit of the Club's Relief Fund. WOR has arranged to broadcast a half-hour period from the Astor on the night of the ball. Among the radio celebrities who will be present as guests of honor are Uncle Don, Harry Hershfeld, Eddie Dowling and Raymond Knight. Johnny Green, whose remarkable record as composer, arranger,

## CORPORATE ACTIVITIES

General Electric Company—Previously reported net income after charges and taxes, \$13,429,738, as compared with net income in 1932 of \$14,044,110, net sales, \$136,657,268, compared with \$147,162,290; depreciation, \$6,179,311, compared with \$6,580,575. A deduction for revaluation of investments in and advances to associated companies was made from surplus to the amount of \$19,498,309. In 1932 a similar deduction amounted to \$19,498,309. Cash, \$60,901,643, against \$107,804,164; securities, \$50,976,864, against \$8,303,852; customers' accounts receivable \$11,509,047, against \$10,692,707; assets created companies' accounts, \$3,573,368, against \$3,727,331; inventories, \$43,467,409, compared with \$41,686,432; current liabilities, \$13,302,576, compared with \$12,869,542.

Acme Wire Company and Subsidiaries—Net income for the year 1933, after depreciation and other charges, \$7,750 capital shares, contrasted with net loss of \$167,862 for the year 1932.

United Radio Products Company—Net loss for the year 1933, after depreciation, development expenses, interest, loss on investments, minority interest and other charges, but before subsidiary preferred dividend requirements, \$34,174. For the year 1932 the net loss was \$312,948.

### "THEATRE OF THE AIR" PASSES

WMA's "Theatre of the Air"—which, by the way, was really the first "air-theatre"—has been given up by that astute radio station. The powers-that-be feel that studio audiences are resented by the stay-at-home listeners who are not present in the "theatre" to view antics of the artists, and artists forget their unseen audience in the presence of a "live" audience, and resort to clowning which does not go out well over the air. WMA, is writing a book on radio. Peter Dixon wrote a radio book several years ago, but Peter says he could write a better one now; he has learned more about the intricacies of radio since then. Jack Foster was heard from last week. He's due back in New York in June. That will be a great re-union for his army friends!

cast, and, as usual, he did a fine job. Helen Morgan. Heard his initial broadcast, "Melodies" series over CBS; he replaces Marshall is the new star of the "Broadway Martini and Grot Stueckgold." Everett field series starring Rosa Fonselle, Nino Chesser, sport commentator, has been signed as an announcer for the new thrice-weekly Chester-Ford Frick, radio a vaudeville tour. Ozzie Nelson, who is booked for replacing the Park Central Hotel in New York, CBS on April 3rd, from the Coconut Grove and Thursday night dance programs over Tuesday at 10:30 p.m. Charles Barnet and his orchestra began a series of Tuesday broadcast over the Columbia network each It is entitled "The Confidant" and will be Store," has just finished his first radio serial. of such novels as "Teetillaw" and "The p.m. T. S. Stripling, renowned author of recitals over CBS. Each Sunday at 6:00 Institute, in Virginia, is presenting a series Southern and one Canadian CBS outlets. work to thirty-nine stations, adding nine-utes in Hollywood" has increased its net-program department. "Forty-five Min-System as musical adviser to the networks been signed by the Columbia Broadcasting pianist, and conductor has placed him in the

### A THOUGHT FOR THE WEEK

SOMEONE we know has just dramatized a globe wanderer who is stuck in the wilds of Africa and who reaches his pal on Park Avenue through his short wave set. The pal gets the location of his friend, who is in a devil of a fix, and goes to Africa and—well, the plot is something of a secret and that's as far as we can go. We mention the matter merely to indicate that short waves influence the drama even as they influence the radio



**TUNING UNIT FOR TEST OSCILLATOR**



**H**ERE is your very first opportunity to get the parts for constructing a universal, modulated test oscillator to cover fundamentals from 135 to 380 kc. and read higher intermediate frequencies and the entire broadcast band, by harmonics, all imparted right on the dial. That is, the oscillator will give direct frequency-reading. The parts consist of one metal-etched scale, one metal-etched oscillator transformer (secondary inductance accurate to 0.1 per cent.), and one knob for condenser. Circuit diagram supplied for universal model modulated test oscillator (90-120 volts a.c., d.c. or battery, same oscillator works on all three). Instruction sheet for lining up at broadcast and intermediate frequencies included. Line up the oscillator with one adjustment on broadcast band, beating with some station on 1,200 kc. Whole dial then will track. Order P.R.E.-TTO and send \$8.00 for one-year subscription for (52 issues). Sent postage prepaid.

**AIR-DIELECTRIC**

For unequalled maintenance of the frequency to which the intermediate channel is adjusted, air-dielectric tuning condensers must be provided. These are supplied on isolating forms, and are made by one of America's premier precision radio parts manufacturers. Quantity at left.

- Complete Selection of Tubes**
- (1) P.R.E.-AD-465... \$6.00 subscription, 52 issues
  - (2) P.R.E.-AD-465... \$12.00 subscription, 104 issues
  - (3) P.R.E.-ADD-465... \$18.00 subscription, 156 issues
  - (3) P.R.E.-ADD-175... \$6.00 subscription, 52 issues
  - (3) P.R.E.-ADD-175... \$12.00 subscription, 104 issues
  - (3) P.R.E.-ADD-175... \$18.00 subscription, 156 issues

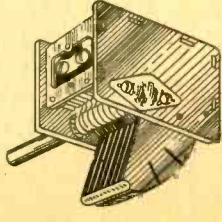

**MICA-DIELECTRIC**

For 465 kc or 175 kc it, we offer doubly-tuned transformers, with mica-dielectric tuning condensers, 2-1/16-inch diameter. Quantity is at left. Sent postpaid.

- Intermediate Transformers**
- (1) P.R.E.-MD-465... \$2.00 subscription, 16 issues
  - (2) P.R.E.-MD-465... \$4.00 subscription, 32 issues
  - (3) P.R.E.-MD-175... \$6.00 subscription, 48 issues
  - (3) P.R.E.-MD-175... \$12.00 subscription, 96 issues
  - (3) P.R.E.-MD-175... \$18.00 subscription, 144 issues

- Single Transformer**
- (1) P.R.E.-MD-465... \$2.00 subscription, 16 issues
  - (2) P.R.E.-MD-465... \$4.00 subscription, 32 issues
  - (3) P.R.E.-MD-175... \$6.00 subscription, 48 issues
  - (3) P.R.E.-MD-175... \$12.00 subscription, 96 issues
  - (3) P.R.E.-MD-175... \$18.00 subscription, 144 issues

The following highest-grade, licensed, brand-new, 10-day-replacement-guarantee tubes are offered as premiums.

One Tube for \$1.00 Subscription, 8 Issues:  
 01A, 01AA, 1V, 1Z, 22A, 24A, 26, 27, 30, 31, 35, 36, 37, 38, 39, 45, 47, 51, 56, 57, 61A, 90, 92, 93

Any two of above tubes for \$2.00 Subscription (16 Issues), any three for \$3.00 Subscription (26 Issues), any six for one-year Subscription (52 Issues).

A new dielectric has been introduced that shows most remarkable properties for high frequencies. The heat losses are not discernible at 75 centimeters. The losses decrease as the frequency increases, contrary to what is called Vitron. It was developed by the United States Rubber Company, although it is not rubber. Special processing is necessary to work this material, hence cost of production runs high, but the results are most astonishing, particularly as tubes that otherwise stop oscillating at 10 meters or so oscillate at lower than 5 meters when Vitron is used as tube base.

**VITAL BOOK**

The biggest help any one can get who desires to wind radio-frequency coils for the fringe of ultra frequencies is to have a book that tells just what inductance is required for the condenser one possesses, and kind of wire on which to wind. The material is arranged in a form that is readable and understandable. "The Inductance Authority," by Edward M. Shippe, gives you just that information, in an accurate 0.1 per cent. Send \$3 for a six-months subscription (\$6 for one year) and order P.R.E.-1A sent postpaid.

**POWER TRANSFORMER**  
 Primary—105-130 volts, center-tapped.  
 Secondary A—2.5 volts, center-tapped.  
 Secondary B—110 volts, no center tap.  
 Splendid for powering a-c test oscillator or any other rectifier for not more than three small tubes.  
 Order P.R.E.-SPTA and send \$1.50 for three-month subscription (13 weeks) postpaid.

**SOLDERING IRON**  
**F R E E !**  
 Works on 110-120 volts AC or DC power, 50 watts. A serviceable iron, with copper tip, 5 ft. cable and male plug. Send \$1.00 for 13 weeks' subscription for Radio World and get these free! Please state if you are renewing existing subscription.  
 148 West 45th St. N. Y. City

**Subscribers! Important!**  
 Note subscription expiration date on wrapper containing your copy of RADIO WORLD. If nearing expiration date, please send in renewal so that you will not miss any copies. Subscription Dept., RADIO WORLD, 145 W. 45th St., New York City.

**JUST OUT!**  
 John F. Rider's  
 Vol. IV  
 Perpetual Trouble Shooter

**S**ERVICING during 1934 will be more complicated than at any time during the past 14 years of radio activity. Volume IV is your means of combating the numerous highly scientific problems of design introduced by the receivers sold during 1933.

"I do not hesitate to say that Volume IV is the most important of all the manuals I have issued. Volumes I, II and III found their place in the service world as important aids to the service man... Volume IV is destined to be more than just an important aid... It will be a vital necessity. I am firm in the belief that because the contents of Volume IV cover the most scientific and complicated radio receivers ever produced in the history of the radio industry—its ownership will mean the difference between success and failure when servicing the 1933 crop of radio receivers.

"You will witness a new era in radio servicing during 1934... and it is only the start of comparative radio service problems... Research laboratories in contact with receiver manufacturers forecast increased service applied to radio receiver design... We are passing out of the three and four tube receiver stage—back into the 8, 10 and 12 tube stage with highly complicated electrical networks... Hourly use of radio service data will be imperative.

Volume IV has in it 1049 pages in the loose leaf binder; about 20 pages in a separate supplement and the index, covering all of the manuals, totals about 40 pages, making a grand total of approximately 1100 pages.

The binder used in Volume IV is identical to that employed for Volume III. It is loose leaf employing the finest of materials. A finger bar "instant removal" mechanism is employed.

Also:  
 Volume I, Rider's Perpetual Trouble Shooters \$7.50  
 Manual \$7.50  
 Volume II—Does not duplicate Vol. I 6.50  
 Manual \$7.50  
 Rider's Combination "3 in 1" Manual, now ready (Vols. I, II and III) 21.50  
 Rider's Combination "3 in 1" Manual, with carrying handles 25.00

Address: BOOK DEPT., RADIO WORLD, 145 W. 45th St., New York, N. Y.

**YOUNG MAN WOULD LIKE POSITION**  
 as assistant in Radio or Electrical Laboratory or Radio Service Shop. Two years electrical school education. Attended Milwaukee School of Engineering. E. Reckentine, 703 Union St., Rome, N. Y.

**"DRAKE'S CYCLOPEDIA OF RADIO AND ELECTRONICS"**  
 The Standard Reference Book for Radio Men. A 5th Edition of the famous Drake's Cyclopaedia covering the whole field of radio and allied arts in one handy volume. 1048 pages, 178 illustrations, 130 tables, 105 graphs. Price, \$5.00 net. RADIO WORLD, 143 West 45th St., New York City.

**"THE RADIO HANDBOOK"**  
 including Television and Sound Motion Pictures. By James A. Moyer and John F. Wostrel, both of the Massachusetts Department of Education. For engineers, designers, operators, service men, experimenters. 886 pages, 650 illustrations, flexible covers. Price, \$5.00. RADIO WORLD, 143 West 45th St., New York City.

**"RADIO AND TELEVISION"**  
 by James R. Cameron. Over 540 pages, 275 illustrations; cloth bound. The subject of radio and television covered in such a manner that it is easily understood even by a beginner. Price \$4.00. RADIO WORLD, 145 West 45th St., New York City.

**STAMMERS' Home remedy—587 Saylor, Elmhurst, Illinois.**  
 Write Michael A. Alvarado, 322 W. 113th St., New York City.

**YOUNG MAN 26 YEARS OF AGE, R.C.A. Institute, Inc., and Capital Radio Engineering**  
 Service Shop; has done some experimental work as assistant in either Radio Laboratory or Radio Institute, Inc., graduate, desires moderate position. Write Michael A. Alvarado, 322 W. 113th St., New York City.

**"RADIO AND TELEVISION"**  
 by James R. Cameron. Over 540 pages, 275 illustrations; cloth bound. The subject of radio and television covered in such a manner that it is easily understood even by a beginner. Price \$4.00. RADIO WORLD, 145 West 45th St., New York City.

**"THE RADIO HANDBOOK"**  
 including Television and Sound Motion Pictures. By James A. Moyer and John F. Wostrel, both of the Massachusetts Department of Education. For engineers, designers, operators, service men, experimenters. 886 pages, 650 illustrations, flexible covers. Price, \$5.00. RADIO WORLD, 143 West 45th St., New York City.

**"DRAKE'S CYCLOPEDIA OF RADIO AND ELECTRONICS"**  
 The Standard Reference Book for Radio Men. A 5th Edition of the famous Drake's Cyclopaedia covering the whole field of radio and allied arts in one handy volume. 1048 pages, 178 illustrations, 130 tables, 105 graphs. Price, \$5.00 net. RADIO WORLD, 143 West 45th St., New York City.

**YOUNG MAN WOULD LIKE POSITION**  
 as assistant in Radio or Electrical Laboratory or Radio Service Shop. Two years electrical school education. Attended Milwaukee School of Engineering. E. Reckentine, 703 Union St., Rome, N. Y.

**STAMMERS' Home remedy—587 Saylor, Elmhurst, Illinois.**  
 Write Michael A. Alvarado, 322 W. 113th St., New York City.

**RELIABLE RADIO COMPANY**  
 145 West 45th Street, New York, N. Y.

**LABEL MICROPHONE**

A single-button carbon-granule label microphone, requiring 200 ohms impedance, good frequency characteristics, and both handy and inconspicuous. The case is chromium-plated brass. The excitation may be provided by 25 milliamperes, or a 4.5-volt C battery in a cathode circuit carrying a biasing phone in a cathode circuit carrying a biasing battery may be used. Net price, \$2.95.

**RADIO WORLD, 145 WEST 45th STREET, NEW YORK, N. Y.**  
 Order P.R.E.-SPTA and send \$1.50 for three-month subscription (13 weeks) postpaid.

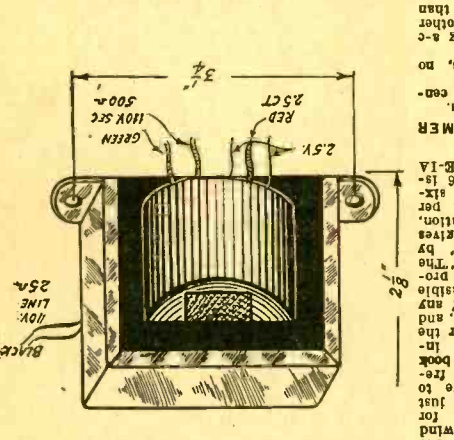

**THE INDUCTANCE AUTHORITY**  
 BY EDWARD M. SHIPPE

**TUBES SENT POSTAGE COLLECT.**  
 Subscription (52 issues), \$18.00  
 Subscription (26 issues), \$9.00  
 Any two of the \$1.50 group for \$3.00 subscription (52 issues), any four for \$6.00.  
 6B7, 6BT, 6Z5, 6Z6, 6Z7, 6Z8, 6Z9, 6Z10, 6Z11, 6Z12, 6Z13, 6Z14, 6Z15, 6Z16, 6Z17, 6Z18, 6Z19, 6Z20, 6Z21, 6Z22, 6Z23, 6Z24, 6Z25, 6Z26, 6Z27, 6Z28, 6Z29, 6Z30, 6Z31, 6Z32, 6Z33, 6Z34, 6Z35, 6Z36, 6Z37, 6Z38, 6Z39, 6Z40, 6Z41, 6Z42, 6Z43, 6Z44, 6Z45, 6Z46, 6Z47, 6Z48, 6Z49, 6Z50, 6Z51, 6Z52, 6Z53, 6Z54, 6Z55, 6Z56, 6Z57, 6Z58, 6Z59, 6Z60, 6Z61, 6Z62, 6Z63, 6Z64, 6Z65, 6Z66, 6Z67, 6Z68, 6Z69, 6Z70, 6Z71, 6Z72, 6Z73, 6Z74, 6Z75, 6Z76, 6Z77, 6Z78, 6Z79, 6Z80, 6Z81, 6Z82, 6Z83, 6Z84, 6Z85, 6Z86, 6Z87, 6Z88, 6Z89, 6Z90, 6Z91, 6Z92, 6Z93, 6Z94, 6Z95, 6Z96, 6Z97, 6Z98, 6Z99, 6Z100.

**SPECIAL SHORT-WAVE TUBES AND SOCKETS**  
 Send \$2 for 16-weeks subscription and select one of the following Vitron-base tubes: 30, 36, 57, 58, or any two for \$4 subscription (34 weeks) or any three for one-year subscription (52 issues) or all four for \$8 subscription (104 issues).  
 Four and three-hole sockets, made of Vitron, are for use with Vitron-base tubes for preservation of gain, and for use as precision, low-loss coil receptacles. Select one socket for \$1 subscription (8 weeks), two sockets for \$2 subscription (16 weeks), three sockets for \$3 subscription (24 weeks), four sockets for \$4 subscription (32 weeks), five sockets for \$5 subscription (40 weeks), six sockets for \$6 subscription (48 weeks), seven sockets for \$7 subscription (56 weeks), eight sockets for \$8 subscription (64 weeks), nine sockets for \$9 subscription (72 weeks), ten sockets for \$10 subscription (80 weeks), eleven sockets for \$11 subscription (88 weeks), twelve sockets for \$12 subscription (96 weeks), thirteen sockets for \$13 subscription (104 weeks), fourteen sockets for \$14 subscription (112 weeks), fifteen sockets for \$15 subscription (120 weeks), sixteen sockets for \$16 subscription (128 weeks), seventeen sockets for \$17 subscription (136 weeks), eighteen sockets for \$18 subscription (144 weeks), nineteen sockets for \$19 subscription (152 weeks), twenty sockets for \$20 subscription (160 weeks), twenty-one sockets for \$21 subscription (168 weeks), twenty-two sockets for \$22 subscription (176 weeks), twenty-three sockets for \$23 subscription (184 weeks), twenty-four sockets for \$24 subscription (192 weeks), twenty-five sockets for \$25 subscription (200 weeks), twenty-six sockets for \$26 subscription (208 weeks), twenty-seven sockets for \$27 subscription (216 weeks), twenty-eight sockets for \$28 subscription (224 weeks), twenty-nine sockets for \$29 subscription (232 weeks), thirty sockets for \$30 subscription (240 weeks), thirty-one sockets for \$31 subscription (248 weeks), thirty-two sockets for \$32 subscription (256 weeks), thirty-three sockets for \$33 subscription (264 weeks), thirty-four sockets for \$34 subscription (272 weeks), thirty-five sockets for \$35 subscription (280 weeks), thirty-six sockets for \$36 subscription (288 weeks), thirty-seven sockets for \$37 subscription (296 weeks), thirty-eight sockets for \$38 subscription (304 weeks), thirty-nine sockets for \$39 subscription (312 weeks), forty sockets for \$40 subscription (320 weeks), forty-one sockets for \$41 subscription (328 weeks), forty-two sockets for \$42 subscription (336 weeks), forty-three sockets for \$43 subscription (344 weeks), forty-four sockets for \$44 subscription (352 weeks), forty-five sockets for \$45 subscription (360 weeks), forty-six sockets for \$46 subscription (368 weeks), forty-seven sockets for \$47 subscription (376 weeks), forty-eight sockets for \$48 subscription (384 weeks), forty-nine sockets for \$49 subscription (392 weeks), fifty sockets for \$50 subscription (400 weeks), fifty-one sockets for \$51 subscription (408 weeks), fifty-two sockets for \$52 subscription (416 weeks), fifty-three sockets for \$53 subscription (424 weeks), fifty-four sockets for \$54 subscription (432 weeks), fifty-five sockets for \$55 subscription (440 weeks), fifty-six sockets for \$56 subscription (448 weeks), fifty-seven sockets for \$57 subscription (456 weeks), fifty-eight sockets for \$58 subscription (464 weeks), fifty-nine sockets for \$59 subscription (472 weeks), sixty sockets for \$60 subscription (480 weeks), sixty-one sockets for \$61 subscription (488 weeks), sixty-two sockets for \$62 subscription (496 weeks), sixty-three sockets for \$63 subscription (504 weeks), sixty-four sockets for \$64 subscription (512 weeks), sixty-five sockets for \$65 subscription (520 weeks), sixty-six sockets for \$66 subscription (528 weeks), sixty-seven sockets for \$67 subscription (536 weeks), sixty-eight sockets for \$68 subscription (544 weeks), sixty-nine sockets for \$69 subscription (552 weeks), seventy sockets for \$70 subscription (560 weeks), seventy-one sockets for \$71 subscription (568 weeks), seventy-two sockets for \$72 subscription (576 weeks), seventy-three sockets for \$73 subscription (584 weeks), seventy-four sockets for \$74 subscription (592 weeks), seventy-five sockets for \$75 subscription (600 weeks), seventy-six sockets for \$76 subscription (608 weeks), seventy-seven sockets for \$77 subscription (616 weeks), seventy-eight sockets for \$78 subscription (624 weeks), seventy-nine sockets for \$79 subscription (632 weeks), eighty sockets for \$80 subscription (640 weeks), eighty-one sockets for \$81 subscription (648 weeks), eighty-two sockets for \$82 subscription (656 weeks), eighty-three sockets for \$83 subscription (664 weeks), eighty-four sockets for \$84 subscription (672 weeks), eighty-five sockets for \$85 subscription (680 weeks), eighty-six sockets for \$86 subscription (688 weeks), eighty-seven sockets for \$87 subscription (696 weeks), eighty-eight sockets for \$88 subscription (704 weeks), eighty-nine sockets for \$89 subscription (712 weeks), ninety sockets for \$90 subscription (720 weeks), ninety-one sockets for \$91 subscription (728 weeks), ninety-two sockets for \$92 subscription (736 weeks), ninety-three sockets for \$93 subscription (744 weeks), ninety-four sockets for \$94 subscription (752 weeks), ninety-five sockets for \$95 subscription (760 weeks), ninety-six sockets for \$96 subscription (768 weeks), ninety-seven sockets for \$97 subscription (776 weeks), ninety-eight sockets for \$98 subscription (784 weeks), ninety-nine sockets for \$99 subscription (792 weeks), one hundred sockets for \$100 subscription (800 weeks).

**Complete Selection of Tubes**

- (1) P.R.E.-AD-465... \$6.00 subscription, 16 issues
- (2) P.R.E.-AD-465... \$12.00 subscription, 32 issues
- (3) P.R.E.-AD-465... \$18.00 subscription, 48 issues
- (3) P.R.E.-ADD-175... \$6.00 subscription, 52 issues
- (3) P.R.E.-ADD-175... \$12.00 subscription, 104 issues
- (3) P.R.E.-ADD-175... \$18.00 subscription, 156 issues

**Intermediate Transformers**

- (1) P.R.E.-MD-465... \$2.00 subscription, 16 issues
- (2) P.R.E.-MD-465... \$4.00 subscription, 32 issues
- (3) P.R.E.-MD-175... \$6.00 subscription, 48 issues
- (3) P.R.E.-MD-175... \$12.00 subscription, 96 issues
- (3) P.R.E.-MD-175... \$18.00 subscription, 144 issues

**Single Transformer**

- (1) P.R.E.-MD-465... \$2.00 subscription, 16 issues
- (2) P.R.E.-MD-465... \$4.00 subscription, 32 issues
- (3) P.R.E.-MD-175... \$6.00 subscription, 48 issues
- (3) P.R.E.-MD-175... \$12.00 subscription, 96 issues
- (3) P.R.E.-MD-175... \$18.00 subscription, 144 issues

**MICA-DIELECTRIC**

For 465 kc or 175 kc it, we offer doubly-tuned transformers, with mica-dielectric tuning condensers, 2-1/16-inch diameter. Quantity is at left. Sent postpaid.

**VITAL BOOK**

The biggest help any one can get who desires to wind radio-frequency coils for the fringe of ultra frequencies is to have a book that tells just what inductance is required for the condenser one possesses, and kind of wire on which to wind. The material is arranged in a form that is readable and understandable. "The Inductance Authority," by Edward M. Shippe, gives you just that information, in an accurate 0.1 per cent. Send \$3 for a six-months subscription (\$6 for one year) and order P.R.E.-1A sent postpaid.

**POWER TRANSFORMER**  
 Primary—105-130 volts, center-tapped.  
 Secondary A—2.5 volts, center-tapped.  
 Secondary B—110 volts, no center tap.  
 Splendid for powering a-c test oscillator or any other rectifier for not more than three small tubes.  
 Order P.R.E.-SPTA and send \$1.50 for three-month subscription (13 weeks) postpaid.



# Reliable Radio

## \$50,000 SPEAKER CLEARANCE SALE!

**SPECIAL - SALE - FEATURE**

### Farrand Inductor Dynamic

The Ideal Short Wave Receiver Speaker:

- Eliminates Hum and Line Noise:
- Draws Less Current:
- The Ideal Short Wave Receiver Speaker:
- Absolutely Genuine Farrand:
- Compact in Size:
- Brings in the Very Weak Short Wave Stations:

Do not confuse this model with the various similar types on the market, posing as Farrands. This is the true Farrand Inductor Dynamic. Its adaptation to Short Wave Radio Receivers has proven a popular step. The most inaudible stations are brought in with remarkable clearness without the customary noise and hum of regular dynamic speakers. Has two magnets parallel to each other with a bracket placed between them to facilitate mounting. Overall 9".

**\$3.95**



### BOSCH SPEAKER CABINET

Will accommodate any magnetic or dynamic chassis up to 10" in diameter. A beautiful walnut cabinet artistically and expensively finished. It was built by one of the foremost manufacturers of cabinet-contrasting color scheme.

Dimensions 12 1/2" high, 12" wide, 10" deep.

Price **\$1.75**



### JENSEN

Model D-7-A.C. DYNAMIC SPEAKER

Widely used as an additional speaker in many homes, as well as on public address systems. Will handle an enormous amount of volume without distortion or rattling. Equipped with a 280 rectifier tube. The speaker measures 12 1/2" high, 11 1/2" wide, and 7 1/2" deep. Supplied complete with tube.

A.C. Model **\$9.95**  
D.C. Model **\$7.95**



### PEARLESS

A.C. and D.C. DYNAMIC SPEAKER CHASSIS

Adaptable for the most powerful amplifier. Equally suited for use with any receiver employing the "R" current, D.C. model has a 1,000 ohm field and a pushpull output transformer. A.C. model used a dry rectifier system with hum condenser for minimum A.C. hum.

Dimensions—12" high, 8" deep.

A.C. Model price, \$8.95; D.C. Model price, \$7.95

6 Volt. Price, \$7.95

All orders are F. O. B. New York, and subject to prior sale. Terms: A deposit of 20% is required with every order. Balance may be paid on delivery. Deduct 2% if full amount is sent with order.

DO NOT SEND FOR CATALOG



### R. C. A. MAGNETIC CHASSIS

Limited Quantity!

This chassis is the identical one used in the R.C.A. 100A-100B and 103 Speakers which list for as high as \$35.00. Note built-in output transformer which permits use of 450 volts without distortion, rating or blasting. The thick armature is accurately centered, the sturdy metal frame is lined with a special self-battering fabric, greatly improving acoustic properties of this sensational speaker. Note the corrugated surface of the cone, an exclusive feature—enhances perfect reproduction qualities considerably; most compactly made; 9" outside diameter, 4 1/2" deep overall.

Price **\$2.75**



### Baldwin A.C. and D.C. Dynamic Speaker Chassis

Power handling capacity of this speaker makes it suitable for use in modern cone sole receiving sets or for power amplifiers. The A.C. models are equipped with a 280 rectifier tube and an 8 mfd. dry electrolytic condenser to reduce A.C. hum. D.C. models are available with or without output transformers. Field resistance of the R.C. model is 2600 ohms.

A.C. Model, complete with tube, Price **\$5.95**  
D.C. Model, with out put transformer, Price **\$4.25**



### FARRAND 12" MODEL INDUCTOR DYNAMIC

The 12" models have two magnets standing upright, with a bracket on the bottom to ease mounting. Dimensions of the 12" model: 12 1/2" high and 6 1/2" deep. (12" Model)

Our Price **\$5.95**



### OXFORD A.C. and D.C. CONCERT

11 1/2" concert model. Three point suspension balanced cone types. A.C. uses 280 rectifier. D.C. models have a field resistance of 2,500 ohms. Output transformer pull output tubes. for single or push pull output tubes.

A.C. with Tube **\$5.75**  
D.C. Model **\$4.50**



### OXFORD A.C. or D.C. Auditorium DYNAMIC

14" auditorium model. Takes a battery with a 12 1/2" range wire frames with extra openings. Oversize speaker higher field strength and permits greater energization. D.C. model has a 4,000 ohm field which can be energized from the power packs of amplifiers or from 110 volt D.C. line.

A.C. with 280 Tube **\$9.95**  
D.C. Model **\$7.95**



RELIABLE RADIO COMPANY  
143 West 45th Street, New York City