

# RADIO

REG. U.S. PAT. OFF.

# WORLD

The First National Radio Weekly

665th Consecutive Issue—Thirteenth Year

Old-Timer  
Tells of Ultra  
Waves He Tried

# CONCENTRIC TUBINGS BEST TRANSMISSION LINE

**DEC. 22**  
1934

**15<sup>c</sup>**  
Per Copy

## Generator with Amplifier Stage

Prompt Shipment Absolutely Guaranteed!

In several services low frequencies are commonly given only their wavelength equivalents, and for very high frequencies this is true likewise. So a Signal Generator, that enables determinations in both wavelengths and frequencies is the thing. That service is what the new Bernard Signal Generator Model 333-A renders.

Besides the more general purpose of lining up superheterodynes at intermediate, broadcast and short-wave levels, and peaking tuned-radio-frequency sets, it may be used as an all-wave Station-Finder, constantly modulated. Dual Measurement and Combination Use make this Signal Generator most valuable.

The fundamental frequencies and wavelengths are direct-reading. There are no charts to strain the eyes. The dial is accurately calibrated and the Signal Generator accurately adjusted. These fundamentals are: 83 to 99.9 kc. (1 kc. separation); 140 to 500 kc. (5 kc. separation); 540 to 1,800 kc. (10 kc. separation); 1,400 to 5,000 kc. (20 to 50 kc. separation); 3,010 to 3,600 meters (25 and 50 meter separation).

The bands are selected by turning a front-panel switch. There are four switch stops. The low-frequency band and the wavelength band cover the same range, the same stop being used, though there are two scales for this band, wavelength and frequency.

Any frequencies or wavelengths as listed above are present as fundamentals and are read directly.

A new method, simple to apply, enables measurements from 4,500 kc. to 99.1 mc., also wavelengths from 3,010 meters to 0.1 meter. The extension of the fundamental ranges is accomplished by a startling method that opens up new possibilities of extensive and accurate measurements.

Model 333-A Signal Generator, for 90-120 volts a.c., d.c. or batteries; designed by Herman Bernard, accurately calibrated and adjusted, for all-wave service, 83 kc. to 99.1 mc., 3,600 meters to 0.1 meter; equipped with output attenuator, on-off switch, modulation switch for d.c. and battery use. Chromium-plated control and band-index scales, positive-contact, low-resistance band-selector switch, a.c. cable and plug, black wrinkle-finish anodized cabinet, 34 and 30 tubes, neon tube, and instruction sheet included. Ready for immediate use.

Model 333-A (shipping weight, 7 lbs.)

List Price .....\$40.00

NET PRICE **\$19.95**

Model 333-AB, wired, tested; 3 tubes. 5 bands, to 16 mc. ....\$21.95

## THREE TUBES!

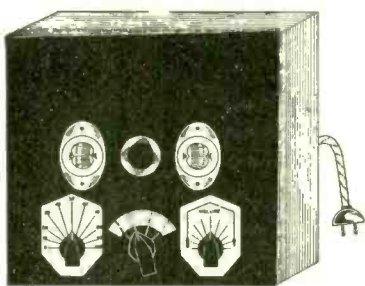

DIRECT RADIO CO.

145 West 45th Street, New York, N. Y.

# You Should Have This

## 192 PAGES SHORT WAVE and PUBLIC ADDRESS MANUAL

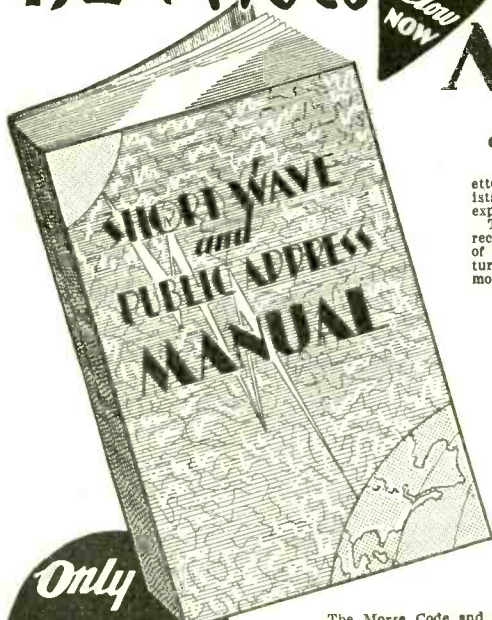

Only **50¢**

"SHORT-WAVE and PUBLIC ADDRESS MANUAL" is an authoritative work, consisting of 192 pages, 5 1/2 x 8 1/2 inches, bound in a cardinal red leatherette cover, and containing contributions by leading specialists on topics of utmost interest and importance to radio experimenters and service men.

The book contains technical articles about short-wave receivers and transmitters, with detailed discussion also of public address systems and valuable ideas on how to turn these systems into paying propositions. There are more than 400 illustrations, and many of these are pictorial diagrams of the wiring of short-wave and public address sets. Besides, the usual schematic diagram is always given for every set, and beautifully clear reproductions of photographs reveal the layout with realistic charm. Contributors include such distinguished authorities as William A. Bruno, Herman Bernard, Arthur H. Lynch, Lewis Winner, George R. Argabrite and Samuel Bagnò. There are more than fifty topics, including the following:

### SHORT WAVES

Complete exposition of a complete assortment of receivers, from one tube to 9 tubes, inclusive; battery, universal and a-c operation; regenerative sets and supers, with pictorial diagrams, schematic diagrams, full photographic illustrations and plain, easy-read text, with list of parts.

Portable Short-Wave Receivers. Design of Plug-in Coils, fully illustrated, with pictures of the completed coils. Full winding data. Broadcast values included.

The Morse Code and the International Code. Short-Wave Tuning Instructions. Short-Wave and All-Wave Antenna Systems. A 5-to-10-Meter Transceiver, with complete constructional details. This set will send and receive between these wavelength limits.

### PUBLIC ADDRESS

Public Address Installations, How to Make Them, What the Requirements Are, and How to Fulfill Them. Power Transformers, Their Types and Uses. Portable Public Address Systems. Factors Governing Amplification in PA Systems. Modern Microphone Trends. Condenser and Velocity Microphones. Volume Controls. Curves, What They Mean and How to Use Them.

### OTHER FEATURES

Besides subject-matter strictly included within the title there are contributions on corollary topics, including Service Oscillators, Broadcast Portable and Home Receivers of Various Types, Data Sheet for Electrolytic Condensers, to Enable Determination of Their Condition and Capacity; Testing Equipment, a General Treatise; Formulas and Data on Radio Receiver Components; Meters and Set Analyzers.

This is strictly a text book and contains no advertising. Order your copy NOW as the edition is limited. Price, 50¢ per copy postpaid, or sent free as a postpaid premium on receipt of a \$1.00

RADIO WORLD 145 W. 45th St., N. Y.

Enclosed please find  \$1 for which send me RADIO WORLD for eight weeks, and mail me postpaid as a free premium "Short-Wave and Public Address Manual."

50¢ for which please send me postpaid a copy of "Short-Wave and Public Address Manual."

Put check mark in appropriate square.

NAME .....

ADDRESS .....

## GIFTS FOR YOU

### Heavy-Duty Power Transformer

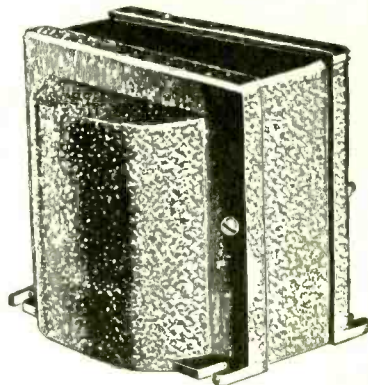

WHY overwork a power transformer, run it hot, get poor results? Here is a power transformer that can be used for any set up to 18 tubes, and with good enough regulation even for Class B. It takes care of 2.5-volt tubes (up to fourteen of them), also one or two 2.5 volt output tubes, whether 2A5s, 47s, 2A3s, etc., and a 5-volt rectifier. Besides, it has a 25-volt winding at 0.6 amperes, so that if you want a second rectifier in a set you may introduce the a-c line voltage to a 25Z5 and take care of the heater from the 25-volt winding. Or, if you want to use four 6.3-volt tubes in series, from this 25-volt feed, you may do so, or even another four such tubes in series, connected in parallel with the other four. There is no other transformer on the market that affords this great versatility. Primary = 115 volts, 60 cycles. Secondary X = 14 amps at 2.5 volts, center-tapped. Secondary Y = 6 amps at 2.5 volts, center-tapped. Secondary HV = 200 ma at 400-0-400 v. a.c. Lug terminals are at bottom. Connection code furnished with each transformer. Shipping weight 13 lbs. Sent express collect on receipt of \$7.00 for 60 weeks subscription for RADIO WORLD (60 issues, one each week). Order P-1012. Remit with order and ask for NP-1012.

### Wide Range of Meters

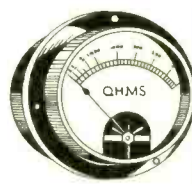

Any one of these d-c meters free with a \$1.50 subscription (13 issues, one each week). P-1020—0-6 v. P-1021—0-50 v. P-1022—6 v. charge tester P-1023—0-10 amp. P-1024—0-25 ma. P-1025—0-50 ma. P-1026—0-100 ma. P-1027—0-300 ma. P-1028—0-400 ma. P-1029—0-3-0 v.

If there is any particular meter you desire, and it is not listed, write in for a subscription proposition. In fact, if there is anything in radio that you want as a premium, we will be glad to make you an offer. Write to Premium Editor, Radio World, 145 West 45th Street, New York, N. Y.

### Precision Tuning Coils

These coils may be used with condensers of from 0.00035 mfd. maximum to 0.0004 mfd. maximum. The inductances of coils are maintained equal by winding them to an identical axial length, spacing the end turns to accomplish this. The tuning is from 540 to 1,800 kc and from 1,620 to 4,800 kc. To utilize the police band, switching is necessary.

Three equal coils for t-r-f set (for use with three-gang condenser). Remit \$2.00 for 16 weeks subscription (16 issues) and order P-1030 sent postpaid.

Four equal coils for t-r-f set (for use with four-gang condenser). Remit \$2.50 for 20 weeks subscription and order P-1031 sent postpaid.

Two equal coils and one oscillator coil for superheterodyne at 175 kc i.f., (requires three-gang condenser). Remit \$2.00 for 16 weeks subscription, order P-1032, and three coils will be sent postpaid. Same as directly above, except for 485 kc i.f. Order P-1483.

Three equal coils and one oscillator coil for 485 kc i.f. (or a four-gang condenser). Remit \$2.50 for 20 weeks subscription and ask for P-1034. Four coils will be sent postpaid. For 175 kc order P-1034-175.

Three doubly-tuned i.f. coils, 485 kc, in aluminum shielding. Remit \$6.00 for one-year subscription (52 issues), and order P-1035 sent postpaid. Same as directly above, only for 175 kc. Ask for P-1035.

### Signal Generator Parts

Tuning condenser, two coils, two precision fixed condensers, frequency-calibrated disc dial, 3-pole-four throw switch, knob, two escutcheons, for 83-100 kc, 140-500 kc, 540-1,800 kc, 1,620-4,800 kc, all on fundamentals. Wavelength calibration also is in scale for the low frequency band. These parts comprise the foundation unit for the 333-A Signal Generator. Diagram included in offer. Remit \$12 for two-year subscription (134 issues) and ask for P-1037 sent postpaid.

## RADIO WORLD

145 West 45th Street, New York, N. Y.

ROLAND BURKE HENNESSY  
*Editor*  
 HERMAN BERNARD  
*Managing Editor*  
 M. K. KUNINS  
*Technical Editor*  
**OFFICERS**  
 Roland Burke Hennessy  
*President and Treasurer*  
 M. B. Hennessy, *Vice-President*  
 Herman Bernard, *Secretary*

# RADIO Reg. U.S. Pat. Off. WORLD

*The First National Radio Weekly*  
**THIRTEENTH YEAR**

Price, 15c per Copy; \$6.00 per Year by mail. \$1.00 extra per year in foreign countries. Subscribers' change of address becomes effective two weeks after receipt of notice.

Entered as second-class matter March, 1922, at the Post Office at New York, N. Y., under Act of March 3, 1879. Title registered in U. S. Patent Office. Printed in United States of America. We do not assume responsibility for unsolicited contributions, although careful with them.

Vol. XXVI

DECEMBER 22, 1934

No. 15. Whole No. 665

*Published Weekly by* Hennessy Radio Publications Corporation, 145 West 45th Street, New York, N. Y.  
 Editorial and Executive Offices: 145 West 45th Street, New York  
 Telephone: BR-yant 9-0558

## The Best Transmission Line Concentric Tubing Operates Without Radiation

*By M. K. Kunins*

**D**URING the introductory days of radio, communication was carried on at low frequencies; or, in terms of wavelength as was the practice then, at long wavelengths, thousands of meters.

For an antenna, operating on these bands, to function on the half or even quarter wavelength, it would have to be of gigantic size,—at least about 850 feet long!

The impracticability of constructing such quarter wave antennas is obvious and the antennas of yore were accordingly only fractional parts of even a quarter wavelength. In this condition, it was usually convenient, and perhaps even more advantageous, to bring the antenna directly into the equipment. Thus, the antenna was all the wire from the antenna terminal on the equipment to the outermost point in the system. Such terms as feeders and transmission lines were not of practical value in the radio system of that day.

### Problems of Higher Frequencies

However, the advent of the higher frequencies has opened up a new vista of problems, prominent among which appears those special points involved in transfer of energy between the antenna system proper and the equipment in use. In this case it is possible to erect antennas that are even several half-wavelengths long so that standing wave patterns are generated or induced and special coupling means are necessary. Furthermore, the proximity of other bodies becomes more of a factor requiring special study. Systematic endeavor in this direction for most efficient antenna energy transfer has evolved many schemes, of which the most common is the two-wire Zepp feeder.

When a feeder is being used to transfer energy between antenna and equipment, it is very important that the feeder does not radiate nor absorb outside energy. Even a small amount of such radiation or absorption may seriously affect the efficiency of the system. While this is the most important point to consider in the design of feeders, other factors of lesser importance are low loss, constancy and ease of adjustment. First cost is another factor sometimes but is also of lesser importance.

The non-radiating type of feeder is the

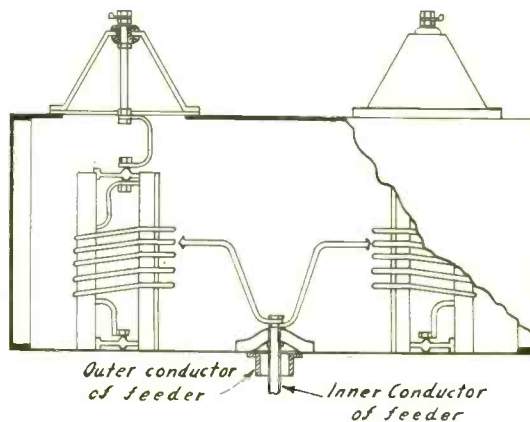
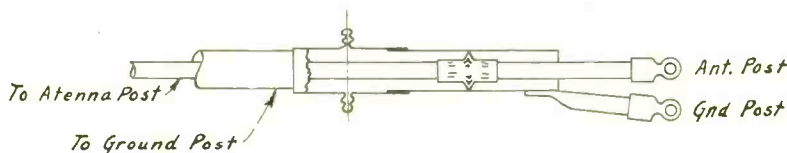

The construction of the concentric tube type of feeder is seen from the upper sketch. The lower diagram shows the construction of a practical impedance matching box.

concentric tube type which consists of a hollow tube, in the center of which and insulated from it is another conductive tube or wire to form the two sides of the feeder. Any stray field that may exist even with this feeder may be minimized by keeping it close to ground and grounding it frequently.

### Losses Considered

Of course, this will convert the system to the Marconi type rather than the Hertz with which the Zepp is associated most frequently. The concentric tube type of feeder is particularly suitable for mounting near the ground since the live conductor is entirely protected from risks of shorts or accidental contact.

The low-loss requirement for feeders is also best met by the concentric tube feeder. Feeder losses come under three separate headings—copper losses, insulator losses and radiation losses. With tubular feeders it is obvious that the

great mass of copper in the tube is conducive to very low copper losses. To minimize this factor, the best ratio of diameters of the tube to the internal wire is 3.5 or 4 to one. This might be a No. 8 B & S wire in a half-inch tube. Since the insulators of the concentric tube feeder are always enclosed, the losses incurred by insulator weathering is reduced to a minimum and permits a permanent installation.

### Zepp Feeders

The radiation loss of this feeder is negligible even when incorrectly terminated because of the shielding effect of the outer tube. This is important since the transmission line can be installed without elaborate precautions and to some extent the ease of installation offsets the greater initial cost. The only disadvantage of this type of feeder is the first cost incurred by the great amount of copper.

*(Continued on next page)*

# An Old-Timer Looks Back

## Tells of Experiments on Ultra Frequencies in 1928

By Clarence Fisher

### REEL CHANGES ANTENNA LENGTH

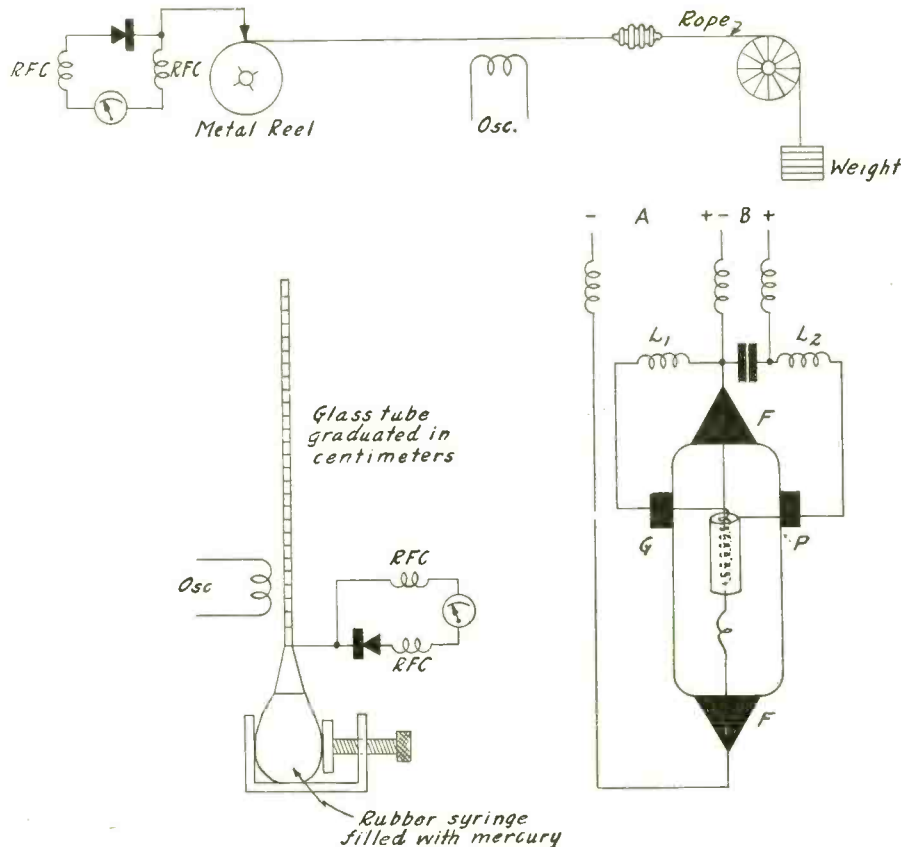

A wire, whose length is made variable by means of a reel and a weight, forms an effective wavemeter (top). A mercury column's height in a thin glass tube is made variable by means of an ordinary rubber syringe and thus furnishes an easily read wavemeter (left). The English Marconi tube in circuit—at a wavelength of one meter (right).

THE writer had occasion to discuss the old days with an old timer and learned that the ultra short waves are not the new thing they are supposed to be. For, he intimated that as long as five years ago, he built an oscillator that worked on one meter. This outfit utilized an uncommon tube in these parts—an

English Marconi V 24, illustrated in the sketch. It will be seen that this tube was chosen because of its special construction whereby the plate and grid leads are quite far apart. In this manner, a reasonably low interelectrode capacity was obtainable, something that is essential for this region in the electromagnetic spectrum.

The dimensions of the oscillatory circuit were interestingly small, consisting solely of two coils,  $\frac{1}{4}$  inch in diameter of No. 18 bare wire. The grid coil consisted of two turns and the plate coil of three turns. With 100 volts on the plate, an input of one-half watt was consumed. In the construction of this oscillatory circuit, it was found that the spacing between the turns of the coils was critical and experimentation was necessary to obtain the wavelength desired.

#### Unique Method

The manner in which the wavelength was measured was also unique. The sketches show two such devices, one utilizing a column of mercury and the other consisting of a reeled wire. In the mercury method, a long glass tube, open at both ends, with an inner diameter of about  $\frac{1}{32}$ nd of an inch and about 4 feet long was inserted into the end of a rubber syringe, containing mercury. This syringe was so mounted that it could be compressed by means of a set screw. The field of the oscillator was fed to the mercury column in the glass tube, the height of this column being controllable by compressing or decompressing the syringe. This was equivalent to an antenna wire of variable length. By means of a crystal detector and a galvanometer, as shown, current nodes or antinodes are found on the mercury column. The procedure in measuring the wavelength of the oscillator is then to compress the syringe so that the mercury column rises in the tube.

#### Action of Galvanometer

The galvanometer will gradually increase in deflection to a maximum point and then it will decrease to zero. The maximum point will represent one-half wavelength while the zero point is the full wavelength. Thus, to measure the wavelength, it is sufficient to compress the syringe till a maximum galvanometer deflection is achieved and read the length of the mercury column. This reading is then multiplied by two to give the wavelength.

The other scheme is similar, except that the mercury column is substituted with a wire on a reel. By unwinding or winding the reel, the length of the active wire, between the reel and the insulator is a measure of the standing wave that is induced in it. In similar fashion to the mercury column method, nodes and antinodes are discoverable by means of the galena crystal and galvanometer.

## "Box" Used for Coupling Feeder to Antenna

(Continued from preceding page)

However, this might even be neglected when it is realized that such an installation is quite permanent and requires a minimum of attention.

In the case of Zepp feeders, the copper losses are also quite small. However, the weather has a marked toll on the life of the insulators and radiation is accordingly most uncertain because of this weathering in addition to swaying of the lines caused by the wind. And, unless this type of feeder is correctly adjusted and terminated so that the current in each wire is exactly the same, radiation losses

are suffered. Though it is a comparatively simple matter to calculate on paper the correct terminating impedances, it is another matter to effectuate the case in practice, especially on the high frequencies.

The superiority of the concentric type of feeder is becoming more generally appreciated when it is realized that the newest broadcast stations are so equipped. Notable examples of this line are found at the transmitters of WABC and WLW among many others.

Opportunities for mechanical strength in the design of these feeders abound and

one of great rigidity and permanence is illustrated in the sketch. The manner in which the inner conductor is maintained in its correct position is shown and it will also be seen that expansion joints are included to compensate for changes in the system's length due to temperature variations. Any such changes would affect the impedance.

At the end of the feeder cable will be seen a method by which it may be connected to radio equipment. Below the cable there will be seen a coupling box by means of which the feeder is coupled to the antenna system proper.

# Noise Sets the Gain Limit

## Tubes, Condensers, Resistors, Electrons and Ions Erect Barrier

By William Edwards

Looking down upon the top of the element structure of a vacuum tube, if it were possible, we would see this arrangement of ions and electrons between the electrodes.

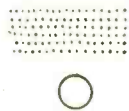
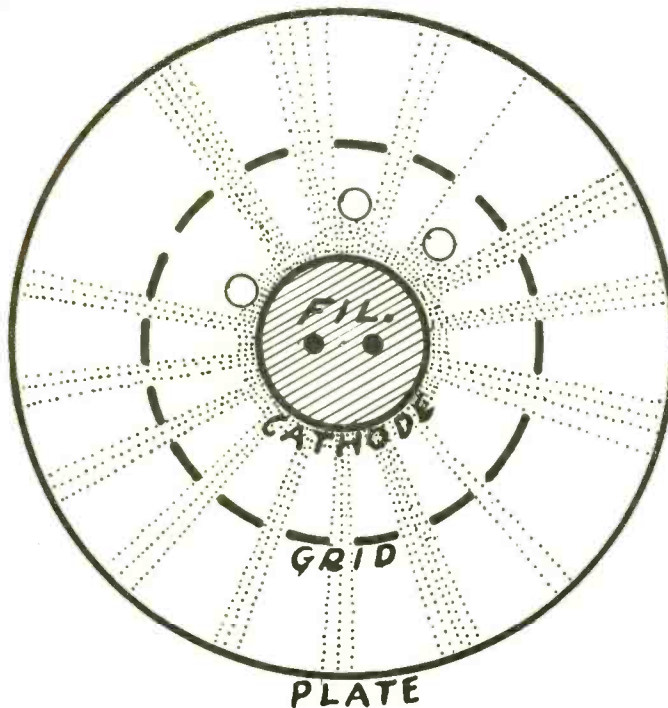

Electrons  
Ions

MANY fans are intrigued by the multitude of tubes available on the market at present and vision apparatus utilizing a profuse number of the different varieties, row on row. These persons should realize that their thoughts are impractical for various reasons, which in a cumulative sense constitute what is known as noise. The greater the number of tubes in a set, the greater will be the noise. Anyone who has had a favorite broadcast program ruined by some sort of noise or other can fully understand the effect of such a background.

The amplification obtainable in a vacuum tube amplifier is limited by the noise in the circuit. That follows directly from what has been said. Of the various sources of noise, two general classes may be categorized: noise from without the equipment and noise from within. We shall concern ourselves here with the noise that is generated within the equipment since external disturbances are not to be generalized for all locations.

### Thermal Agitation Serious

The most fundamental and most inevitable of the internally generated noises in an amplifier circuit is the thermal agitation of electricity. Other sources are influence of ions on the electronic stream, of shot effect and flicker effect on the current in a vacuum tube, poor contacts in the circuit proper or in the tube itself, mechanical vibration, and hum from heat-

ing of the cathode with alternating current.

Although the natural noise level of an amplifier is exceedingly low, modern amplifiers have reached such a stage of sensitivity that their noise levels are often practically at the natural lower limit. In dealing with these effects the first stage of the amplifier (circuit and the vacuum tube) is the most important. For it is here that the signal is at its lowest level.

The various noise effects mentioned above may be briefly described as follows:

**Shot Effect.** Under certain conditions a noise is produced that depends on the fact that an electric current is a flow of discrete particles, electrons emitted by the filament or cathode in a random manner. This random emission produces fluctuations in the current that flows through the tube and output impedances. This fluctuation appears as noise in the output.

### Low Frequency Trouble

**Flicker Effect.** When oxide coated cathodes are used, fluctuations of large magnitude are superimposed on the shot effect currents. Though it is inappreciable above ten kilocycles, this effect is increasingly noticeable below this frequency. This disturbance has been ascribed to a state of flux and change in the activating material on the cathode surface (analogous to a flickering candle).

**Ionic Influence.** In the electronic stream emitted from the cathode there will also

be found a number of positive charges or ions. The greater mass of these particles causes them to contribute to the space charge surrounding the cathode for a longer interval while its own charge contributes little to the current. One ion may cause currents to change by an amount equivalent to hundreds of electrons during flight through the space charge region.

**Hum From Alternating Current Cathode Heating.** Even under the best conditions hum level of an a-c cathode is 20 db above the tube noise measured when d-c is flowing through the cathode. Extreme precautions are necessary with filter circuits in the reduction of this induced current.

### Conduction and Insulation

**Vibration.** This effect is often alluded to as "microphonics" and relates to the change in the relative positions of the tube elements when jarred, resulting in an echoing, ringing noise.

**Poor Insulation.** Temperature and humidity changes cause insulators of poor quality to change their characteristics, so that varying amounts of current are allowed to leak across a load. This variation may occur within a leaky condenser or due to changing of dust and oxidation on other parts. The noise thus produced will also sound like sputtering.

**Faulty Resistance.** Resistors that change their resistance appreciably with voltage or current change furnish a pernicious noise evil.

It is evident from the foregoing that though we hear of this device being a static eliminator or that device being a noise pacifier, there are certain failings that are innate with thermionic tubes which cannot be minimized further. Thus we are limited in the extent to which we may add audio frequency amplification stages upon each other.

## Dr. Simpson Is Host

### To Noted Amateurs

At the Hotel Commodore, New York City, Dr. Burton T. Simpson, W8CPC, president of the Atlantic Division Radiofone Association, recently gave a luncheon to a group of amateurs interested in radio telephone. Among the guests were Colonel Davis S. Boyden, W1SL, of Boston, Mass., president of the New England Radiofone Association; Richard Bartholomew, K4SA, of Porto Rico; Dr. James M. B. Hard, X1G, of Mexico City; Lester E. Gavitt, W1CWH, of Brookfield, Mass.; Morton B. Kahn, W2KR, of New York; Herman G. Mustermann, W2TP, of Leona, N. J.; Frank L. Kaltman, W2AFQ, of Newark, N. J.; Dr. A. L. Walsh, W2BW, and several others from New York City.

The problems of better practices on radio telephone were discussed and plans were made for a meeting in the near future of the Hudson Division Radiofone Association.

# What Four Tubes Can Do

## Tested Design of a Universal T-R-F Set

By Clarence L. Walters

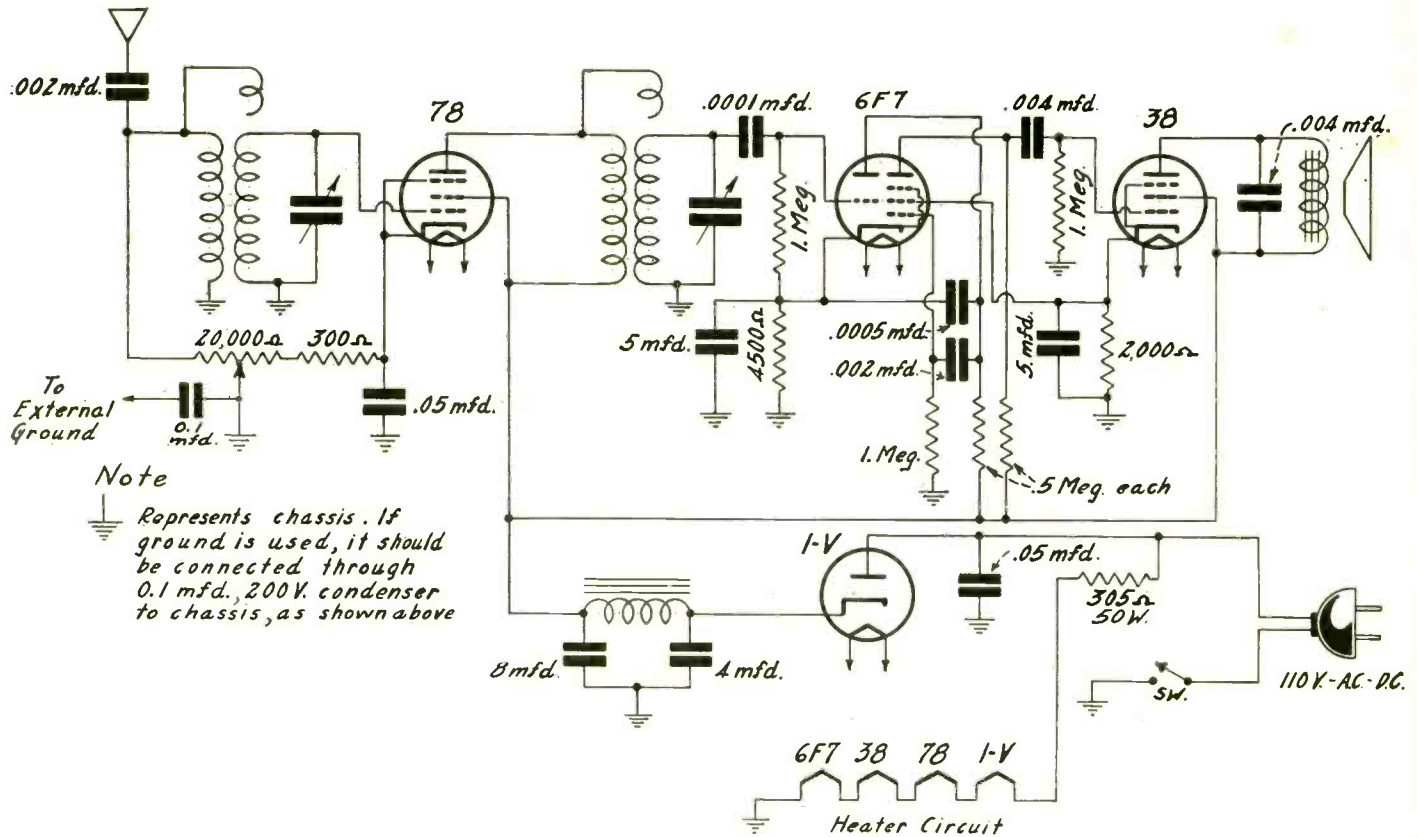

This is a compact 4-tube a-c/d-c set that performs equally well on either type power supply line.

GIVEN the assignment to produce a four-tube receiver that can be built to a very small size, one engineer solved it by the method shown. This is a tuned radio frequency receiver. It has two tuned stages, the r-f amplifier and the input to the detector. The 6F7 is used as detector and as first audio amplifier. The output tube is a 38 pentode. The rectifier is the 1-V, a heater type tube. So universal operation is enjoyed. The limiting resistor should be 302 ohms, 50 watts, and may be built into the a-c cable assembly.

To get as high gain as possible the transfer is made large, or coupling close, and to make possible the existence of such gain over the broadcast band with approximate equality a choke coil is used as the load, and a very small extra winding serves for its condenser effect in coupling to the tuned secondary. This is true in both tuned stages.

### Magnetic Speaker Used

The choke coils are not inductively related to the secondaries, but are at minimum coupling angle, that is right angles to secondary, and the capacity present in the two or three turns is plenty to couple the circuits.

The volume control is a potentiometer, leading from the 300-ohm limiting resistor of the first tube (78). Instead of this potentiometer being connected directly to the return circuit, that is, chassis, the return is led through the choke coil, in the antenna circuit.

The circuit works a small magnetic speaker. So that the intensity will be sufficient on low notes it is necessary to include a high capacity across the biasing resistor of the 38 circuit. This capacity is shown as 5 mfd. and is an electrolytic condenser.

The B current drawn by the set is small, and therefore the choke coil need not have a high inductance, also the plate current may be safely passed through the field winding of a magnetic speaker. However, due to the characteristics of speaker and output tube, the high audio tones would be too strongly accentuated unless some compensation was introduced. The compensation is present as a condenser of 0.004 mfd. across the speaker field winding.

### Series Heaters

The heaters are wired in series. The arrangement selected was the one that best suited the layout, although the rectifier was put next to what would be the positive side of the line for d-c, considering the heater circuit. This is always good practice, because the rectifier is built to stand a high voltage between cathode and anode. First comes the series resistor, naturally, then the rectifier, and the other tubes then may follow in any order, although the one shown has been used in production and has proved good, so many may prefer to follow authenticated practice.

The radio-frequency tube is of the remote cutoff type, as is the 6.3 volt equivalent of the 58. The 6F7 is two triodes, consists of a triode and a pentode, with triode as detector and pentode as amplifier.

### Common Voltage

The input to the detector grid is shown at left, the plate atop that grid is the output of the detector, loaded with 0.5 meg. and coupled by 0.002 mfd. to the grid of the pentode, which is the dashed line at right just above the cathode. The screen is the lead that goes to the cathode of the 38. This is an economical way of getting the low voltage required for this screen, although in fact that negative bias on the 38 has been lifted a bit so as to constitute the voltage a good compromise between what it should be for the screen of one tube and what it should be for the grid of the next tube.

The values of the constants are shown on the diagram.

### CORPORATION REPORT

Weston Electrical Instrument Corporation and domestic subsidiary—After Federal taxes, depreciation and other charges, net profit for the nine months ended Sept. 30 is \$92,178, that equals, after dividend requirements on \$2 Class A stock, upon which is an addition of profits of unpaid dividends, to 25 cents a share on 160,583 no par common shares, compared with net loss, in first nine months of 1933, of \$70,065. Based on six and nine month reports, net profit, quarter ended Sept. 30, is \$9,415, equal to 27 cents a share on 34,800 no par Class A shares, contrasted with 13 cents a common share or \$38,784 in quarter preceding and in third quarter last year, 26 cents a share on Class A stock or \$9,121.

**LIST OF PARTS**

**Coils**

Two radio-frequency transformers, with choke primary loads coupled to secondary by the capacity effect of a small extra winding  
 One magnetic speaker  
 One 15-henry choke coil (or the secondary of an old audio transformer may be used)

**Condensers**

One 0.0001 mfd. mica fixed condenser  
 One 0.0005 mfd. mica fixed condenser  
 Two 0.002 mfd. mica fixed condensers  
 Two 0.004 mfd. mica fixed condensers  
 Two 0.05 mfd. tubular condensers  
 One 4 mfd. electrolytic condenser, 175 volts  
 One 8 mfd. electrolytic condenser, 175 volts  
 Two 5 mfd. electrolytic condensers, 20 volts  
 One 0.1 mfd. condenser, 200 volts, to be included if external ground is used

**Resistors**

One 300 ohm pigtail resistor  
 One 305 ohm 50 watt resistor built into a-c cable  
 One 2,000 ohm pigtail resistor  
 One 4,500 ohm pigtail resistor  
 One 20,000 ohm volume control with switch  
 Three 1 meg. pigtail resistors  
 Two 0.5 meg. pigtail resistors

**Other Requirements**

One chassis  
 One a-c cable  
 One line switch (built into volume control)  
 One dial  
 Two knobs  
 Three grid clips

# Essential Requirements for High-Fidelity Audio

By **Leo K. Messenger**

When a sound is reproduced by a radio system it must fulfill the following general requirements in order to appear to be similar to the original sound that actuated the microphone:

- (a) There should be no other sounds.
  - (b) Its wave form should be similar to the original sound.
  - (c) It should be about as loud.
- The quality of the apparatus' output is determined by the degree to which these conditions are met.

It is necessary that there should be no other sounds for obvious reasons. These noises are either generated externally from the circuit or internally and the treatment of these parasites requires appropriate shielding, transmission lines, and careful layout of parts.

**Wave Shape Preservation**

So the output wave shape be a faithful reproduction of the input wave shape it is essential that:

- (a) Input and output should bear the same proportionality independent of the amplitude of the input.
- (b) Input and output amplitudes be independent of the frequency.
- (c) Input and output components' phase relations be unaltered.

A sound is said to be distorted when any one or more of these requirements

is not met. Respective deviations from conditions are termed amplitude distortion, frequency distortion, and phase distortion.

Amplitude distortion is quickly noticed by the ear and for the critical listener represents an unpleasant experience. Experiments have shown that if this distortion is less than 5 per cent. of the original sound it is not objectionable.

**Frequency Distortion**

Frequency distortion is not disturbing to the ear since it is not noticeable except when it reduces the relative power of any component frequency more than half. When it occurs it does not completely eliminate any one frequency nor does it introduce any new ones. It merely changes the relative amplitudes of the component frequencies already present.

Phase distortion is totally disregarded by the ear. However, it is a vital factor in visual systems, since the eye readily detects its effects.

The requirement that the reproduced sound be almost as loud as the original is readily feasible. It is of importance since the ear will introduce distortion of itself if the sound is heard at a very much different level of intensity.

Design that takes cognizance of these quality factors in radio apparatus will result in a radio system that is unquestionably good.

## THE AMATEUR ORACLE

Address Questions Concerning Amateur Regulations and Technique to **M. K. Kunins (W2DPS)**, Technical Editor, Radio World, 145 West 45th Street, New York, N. Y.

**Condenser Mike Amplifier**

PLEASE INDICATE a circuit that may be utilized to amplify the output of a condenser microphone head.—L. K.

The diagram is shown on this page. It will be noted that the circuit utilizes two type 30 tubes which allows for battery operation. For best results, it is important that the output transformer be matched to the line leading to the transmitter.

**Trouble with Universal**

I HAVE a six-tube a-c/d-c superhet that went bad. Checking it up for voltage, I found that the rectifier voltage output was 25 volts. Please suggest possible faults. Also, please advise as to how this equipment is able to work on both a.c. and d.c.—Z.M.

The low output voltage of your power supply indicates that this supply is partially shorted—either through a leaking

filter condenser, a grounded resistor, a faulty rectifier tube, or other miscellaneous causes. It is suggested that you first test your rectifier tube for condition. Then investigate for bad condensers, and then for grounded points.

Regarding the a-c/d-c feature of this circuit, as the result of examination it will be noted that no power transformer is used. Therefore, when using d.c., the current does not have to go through a transformer which, of course, it won't do. The only precaution that is necessary is that the correct polarity be connected to the rectifier tube since it will perform its function only when the polarity is correct.

\* \* \*

**For the Ultras**

I AM INTERESTED in the ultra-high frequencies. Can I use any circuit for a transmitter on these frequencies?—L. B. M.

Ordinary circuits cannot be used on the ultra high frequencies because of the harmful effect of stray capacities. The push pull circuit, page 13, tends to minimize these capacities and will probably be found very effective. The coils are of about five turns or so on a diameter of about one half inch.

\* \* \*

**Wavelength Formula**

IS IT POSSIBLE to determine what wavelength by applying a formula?—J. S. A.

Yes. Substitute the appropriate values of capacity and inductance in the following formula:

$$\text{wavelength} = 1884 / \sqrt{LC}$$

where wavelength is in meters, L is in microhenries and C is in microfarads.

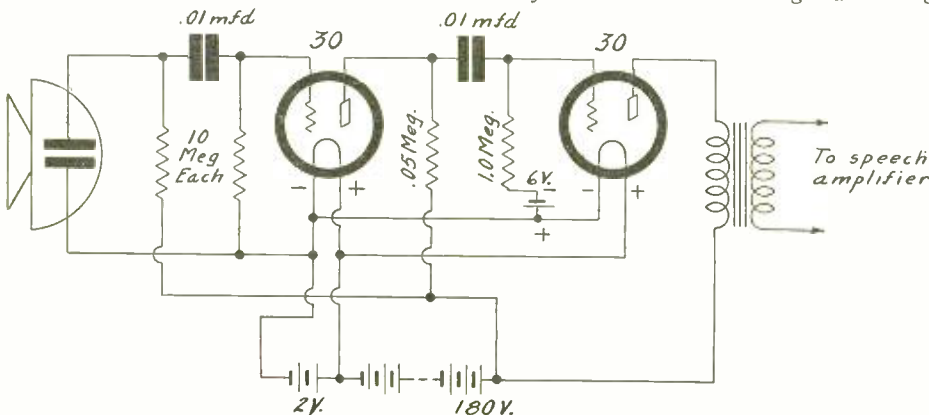

A speech amplifier for a condenser microphone utilizing dry cell tubes for portability's sake.

# The Percentage of Modulation

## It's Comparison of the Audio Amplitude To the Carrier Level

By Percy Hawthorne

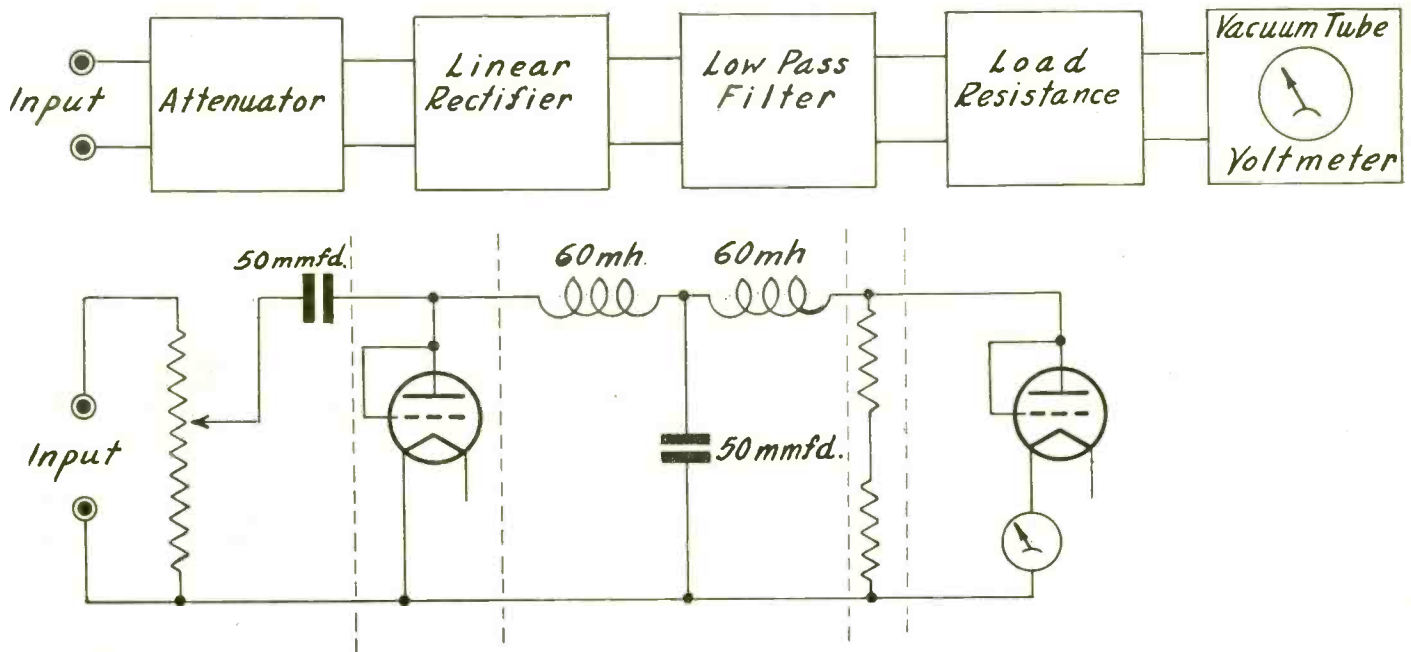

The essentials of a modulation meter are shown as an attenuator, a linear rectifier, a low pass filter, a load resistance, and a vacuum tube voltmeter.

THE use of radio telephony to supplant radio telegraphy in large measure was inevitable, especially induced by the development of broadcasting. It could not be expected that the nation would turn to learning the telegraph code en masse to benefit from the blessings of radio. Of course, you can't send music in the form of telegraphic code, either.

Accordingly, the development of telephonic processes has been a story of steady advancement. First, it was the carbon microphone with its incessant hissing background, to be eventually supplanted by the condenser, dynamic and velocity microphones for quality telephone reproduction of sounds. These later developments were milestones in the endeavors being made to produce a high quality radio telephone system and produced the desired results. However, an elemental aspect of quality determining factors was disregarded. This was the imperfect combination of tubes and circuits whereby the carrier frequency was modulated by the sound frequency to just the correct amount. This amount should be determined between the limits of the distortion zone and the zone of inefficient effect upon the carrier amplitude.

### The Fuzzy Old Past

During the days when this aspect of modulation was being disregarded, the programs that were broadcast contained a great amount of fuzziness, induced by overloading of the carrier. When the soprano hit a certain note with gusto, the radio receiver blared out a noise that contained quite a fuzzy tail—of course,

not a true reproduction of the original sound. No wonder the really good musicians refused to perform for our young broadcasting stations. However, now since every broadcasting station has become modulation conscious, the virtuoso no longer looks upon the radio with contempt. What is this consideration that has so renovated the character of the signals that emanate from the broadcasting stations and why should not amateur radio-telephone stations be similarly minded? Well, there is no reason why the amateur should not be so minded and the details concerning this matter may be gleaned from the following paragraphs.

Convention has named this slighted aspect of telephony "percentage of modulation." It is concerned with the degree to which a carrier frequency is affected by a modulation frequency, and a definition of it that is widely accepted has been proposed by the Standardization Committees of the Institute of Radio Engineers as follows:

Percentage of modulation is defined as the ratio of half the difference between the maximum and minimum amplitudes of a modulated wave to the average modulation, expressed in percent. It is generally determined by measuring the instantaneous value of peak voltages either of the radio frequency oscillations or of the rectified signal wave. Measurements made in this way may be rendered more difficult by the presence of harmonics, especially under conditions of overloading. If the peak voltages are measured by means of oscillograph records, these disturbing factors are of course apparent. The use of an

oscillograph is difficult outside of a laboratory and it is therefore convenient to define a quantity which may be called the effective percentage of modulation, which in the absence of distortion is equivalent to the percentage of modulation, but which is more convenient to measure

Effective percentage of modulation, applied to the modulation of a single carrier by a single sinusoidal signal wave, is the ratio of the amplitude of the fundamental component of the envelope to the amplitude of the unmodulated carrier, expressed in percent. For the case of modulation by a simple sinusoidal wave, in the absence of distortion, it is evident that percentage of modulation and effective percentage of modulation are the same. Effective percentage of modulation, as applied to the modulation of a single carrier, by two or more sinusoidal signal waves, is the sum of the effective percentage associated with the individual signal waves, each measured in the presence of the other.

The definition of effective percentage of modulation as applied to speech necessarily involves some arbitrary qualifications. It is neither easy nor significant to apply the first stated definition to any particular syllable of extended speech. Speech intensity may be measured by means of volume indicators. These volume indicators give a measure of the average speech energy in arbitrary units and are capable of reproduction.

Very good correlation with regard to distortion is obtained between the behavior of speech and of two tones of equal



intensity which give the same reading as the speech on the volume indicator. Effective percentage of modulation, as applied to speech, therefore, may be taken as equivalent to that of two tones of equal intensity. The volume indicators measure the speech power, while percentage of modulation is concerned with peak amplitudes. Two tones, the sum of whose amplitudes is double that of either alone, have together only twice the power of either alone. To obtain this double amplitude, by a single tone involves multiplying the power by four. This gives a power ratio of two. Hence, the effective percentage of modulation for speech may, without change of meaning, be defined as being the same as that for a single tone whose power reading on the volume indicator is double that of the speech.

### The Practical Attainment

Essentially, definitions are pedagogical affinities and as such have no real significance to the practical man in the field. What he is interested in is how will he measure this unit? As has been intimated, this factor is measured either by noting the peak voltages of the radio frequency oscillations or of the rectified signal wave. Accordingly, it is proposed that a modulation meter might perhaps be best constructed to contain the essentials indicated in the block diagram. This involves a means of feeding a portion of the radio frequency output of a telephone transmitter to an attenuator, where it is reduced to a level that will not wreck the instruments; then to a rectifier tube, which will transform this high frequency oscillation to a pulsating direct current; then to a low pass filter which will bar all currents except the original sound currents; and finally a suitable resistance load across which these sound currents will produce a voltage drop that can be measured by a vacuum tube voltmeter.

The fact that a modulated signal is affected to a high degree—said to have a high percentage of modulation—is not sufficient to indicate that a given signal will be of high quality. It is possible that the modulation is not symmetrical, similar to the conditions sketched in the two figures of wave shapes shown on top of the waves illustrated as diseases of modulation. Here, it will be noted, that either the positive or the negative sides of the modulating wave has been distorted by poorly designed equipment which will produce a decided defect in the signal's quality. Accordingly, it is advantageous to include a switching arrangement in the design of the modulation meter which will allow for measurements of both positive and negative peaks. Thus, a modulation meter should be capable of measuring both positive and negative peaks in order to produce a complete picture of the effectiveness of the modulation process.

### Non-Symmetrical Results

In the diagrams of wave shapes of various diseases of modulation will be noted that there are essentially two types of disease, that involving asymmetry of modulation and that concerned with percentage of modulation. Asymmetry may be induced either in the modulator, when the resulting wave will appear as shown in the first two sketches, or in the radio frequency stages, where the envelope itself is distorted. By utilizing the modulation meter, it can readily be determined which of these conditions exist, if they do, and a remedy may then be knowingly provided. This would involve a change in the biasing voltages applied to the respective tubes. With this meter, it is possible to make the measurements while the changes are being made so that an imme-

diately check on the effect of the change is available.

With regard to changes in the percentage of modulation, similar action can be taken so that the results of various changes are directly evident. In the third sketch will be seen the effect of over-modulation. Here, the modulation voltage has been allowed to swing beyond the zero point of the carrier so that it is lost. This results in a distortion of the signal that, of course, should be avoided. The modulation voltage should be reduced to achieve this end and caution should be exercised in this endeavor that it is not reduced too far since this will result in an undermodulated wave pictured in the fourth sketch.

While an undermodulated wave is not as serious as an overmodulated wave since it does not distort the signal, it does not however make full use of the capacity of the carrier wave and is thus wasteful of carrier energy. In other words, an undermodulated signal will not carry as far as one that is fully modulated.

### Complex Case of Voice, Music

The final sketch shows the condition where a carrier wave is fully modulated. However, this condition is only attainable when the modulation consists of a pure tone of constant amplitude, since should the amplitude increase slightly, the overmodulated state occurs and should be amplitude decrease slightly the undermodulated state exists. Accordingly, when the modulation consists of voice currents or music, where the amplitude is constantly changing, it is not possible to obtain a uniform percentage of modulation. Herein lies an inherent weakness of the unit known as percentage of modulation, however, no better arrangement has been presented and accordingly it has to serve the purpose as best it could. In the case of these speech or music modulations, it is necessary to adjust a transmitter for average conditions or maintain a variable gain control that is adjusted with the modulation as is the practice in modern broadcast stations.

### Incredible But True

In the construction of his first piece of radio equipment, many a beginner with a lack of understanding of fundamental electrical principles has failed to trim the insulation off the ends of the wires that he uses for connecting the circuit components together. Thus he fails to make connection between the parts and the terminal posts so that his equipment is inoperative just as if he had not gone through the wiring motions. Therefore, it is essential for the rank beginner to appreciate that the ends of his hook-up wire should be neatly trimmed of insulation so that good electrical contact can be had between the terminal posts and the wire leading to other parts of the circuit.

### Custard Cups, No Less

Pyrex insulator bowls for the transmission line's entry into the shack has been a luxury that could not be afforded by some hams. However, when the cost is twenty cents this "luxury" becomes a necessity. For, it is by that small expenditure of money that a contributor furnished his ham shack with two sets of these gleaming items. Four pyrex custard cups were purchased. The only treatment that was necessary was to drill a hole on the flat part of these bowls to allow the passage of the transmission line. And it is surprising how easily these holes are drilled, in this instance it went like a hot iron through butter—almost.

## Modulation Effect As Observed on An Oscilloscope

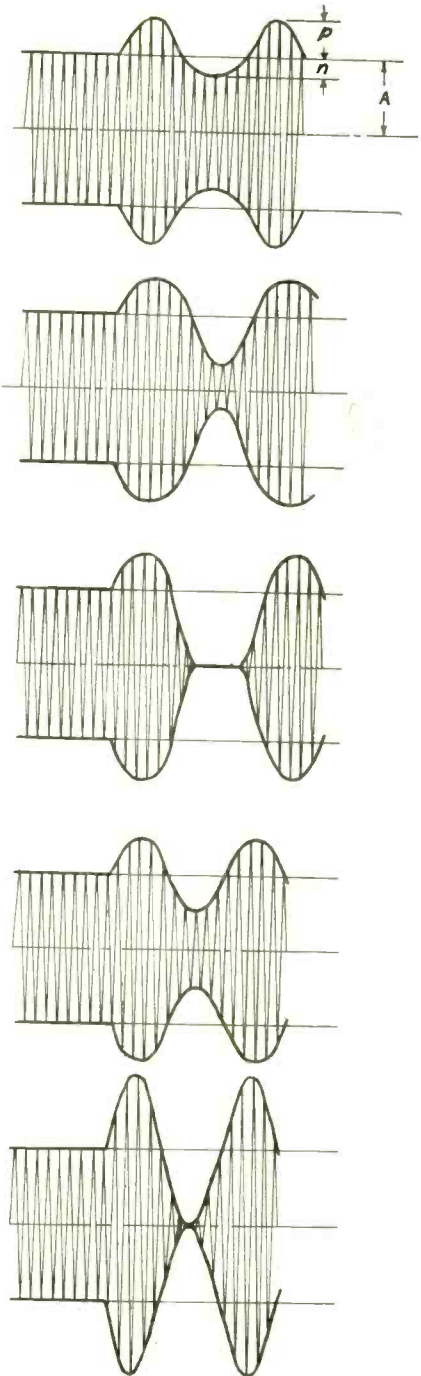

Here are some of the diseases of modulation.

The uppermost figure shows the condition where the positive side of the modulation wave is greater than the negative side which is caused by the operation of the modulator tube with too much grid bias, near the lower bend of the tube's characteristic. The next sketch shows the same condition with the negative side greater than the positive side, due to operation near the saturation point. Both these cases are examples of undermodulation, since the entire carrier wave is not modulated. In the third drawing will be seen an illustration of overmodulation. Here the modulation from the modulator tube is greater than the swing available at the oscillator and results in the zero effect between waves that is evident. This introduces distortion and thus is more undesirable than undermodulation which merely wastes power. The last two sketches indicate distortionless modulation, the former being undermodulated and the latter being fully modulated.

# Why the 2A3 Tubes Excel

## Powerful Filament, Enormous Mutual Conductance—Requirements Exacting

By H. C. W. Fuller

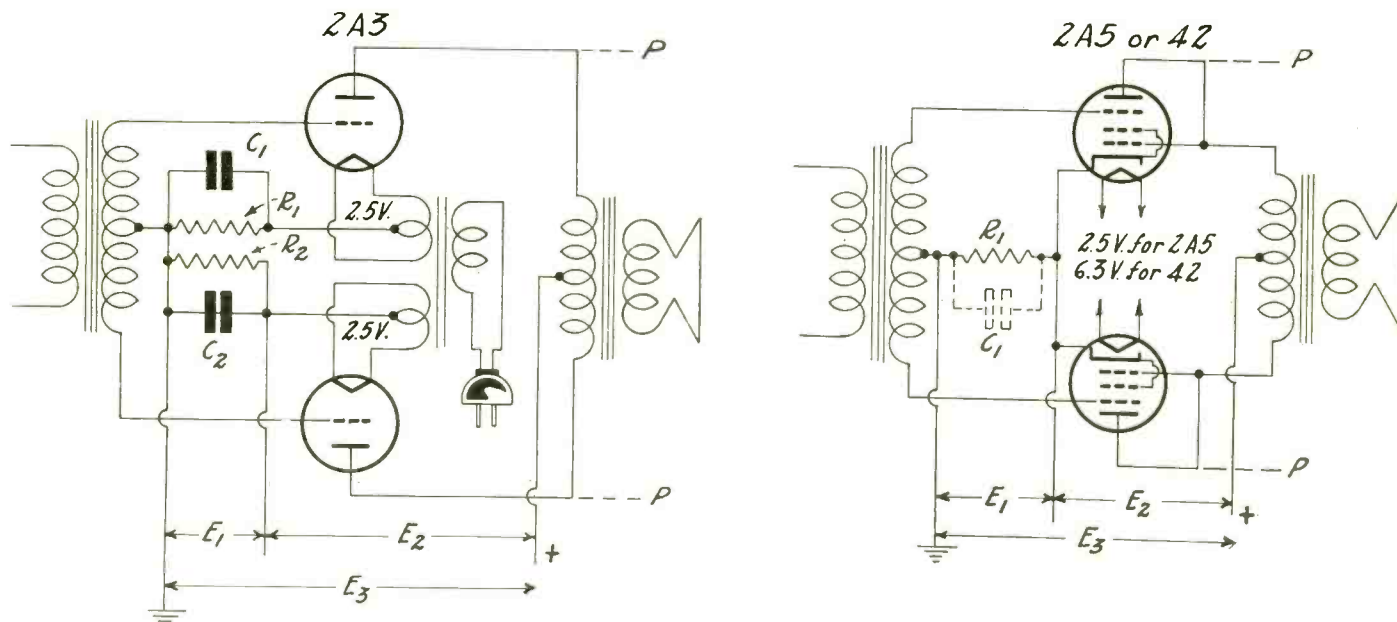

The 2A3 is by far the best power tube for receiver use, due to its powerful cathode and the tremendous mutual conductance, nothing like that conductance being present in any other such tube. Certain precautions in the use of the 2A3 tubes in push-pull, Class A or AB, are necessary, one being equalization of the bias. This may be accomplished with separate heater windings and separate biasing resistors. For Class AB the output at fixed bias is 15 watts, 2.5 per cent. total harmonic distortion. The 2A5's or 42's as triodes afford the same output, 15 watts, using self-bias, but with twice as much total harmonic distortion.

EXPERIMENTERS always are on the lookout for ways to improve the audio. One of the considerations of prime importance is the output stage. It must have been noticed that high-class receivers usually have 2A3 tubes in push-pull output. De luxe type receivers may have 2A3's in push-pull parallel, for 30 watts output. It is not pretended that any home requirements would call for 30 watts. Instead it must be assumed such a receiver is intended mainly for the auditorium or theatre.

The 2A3 tube is extraordinary because of its filamentary construction and its high conductance. In fact, in the receiving group there isn't another tube of comparable conductance. Imagine the 2A3 conductance, which is 5,250 micromhos. Tubes with high conductance have low plate resistance. The two terms are approximately reciprocals. So we find the 2A3 has 800 ohms rating for Class A service. The 45 in the same service has a conductance of 2050 micromhos and a plate resistance of 1700 ohms. Hence the 2A3 has 2.5 times the conductance of the 45 and .47 per cent. of the 45's plate resistance.

### Provides the Supply

The cathode structure consists of numerous series-parallel filaments to enable the large emission. It is one thing for a tube circuit in theory to be able to draw a certain number of electrons under stated operating conditions. It is another thing to supply a large source of electrons. This the multi-filamentary cathode does. It constitutes an engineering development of no small consequence.

There are certain penalties attached to the use of such a tube as the 2A3, if penalties one may call them. The 45 draws 1.5 amperes in the filament circuit, the 2A3 draws 2.5 amperes. More power is needed because more electrons are to be supplied. Besides, if a tube has a high conductance, any small change on the grid side introduces a relatively larger change on the plate side, compared to a low conductance tube. In reality, the mutual conductance, as it is called, is a measure of the change in plate current compared to change in grid-voltage input. Hence mutual conductance combines in one factor the amplification and the plate resistance.

To avoid unbalance, one of the evils in makeshift push-pull circuits, it is necessary that the grid bias effects be equalized in the push-pull 2A3 circuit to a greater extent than required by any other tube in receiver use, although the principle holds of course for all tubes, and unless there is perfect symmetry there is no real push-pull.

### A Proposed Solution

And in passing it may be remarked that due to various causes there is in general seldom a true push-pull amplifier or power stage, as to establish one requires the adoption of precision measurements and adjustments. However, nobody is deterred from introducing as nearly full a measure of symmetry as possible. And the equalization of bias effects in the 2A3 case is vastly important.

A method proposed for doing this is to use a separate winding for the filament of each 2A3 in the push-pull stage. Perhaps this is a concession to a difficulty in

making these tubes in production exact duplicates of one another. Small differences may be present in the tubes and these may be ironed out by equalization of the biasing effect, to the extent of establishing such conditions that equal change takes place in each biased leg. When the changes are equal, the tube characteristic not being disturbed, the plate current effect will be equal. Thus with two equal resistors in the 2A3 circuit, R1 and R2, the current through each may be noted, and if a bit different at no signal input, the unbalance is obvious. The biases are not the same for the same equal resistances because the currents are unequal, hence a signal that introduces an equal but opposite change in each side of the a-c input circuit will produce an output unequal by the proportion of the inequality of the biases. Therefore the relationship should be altered to produce the same static bias in each branch, by adjusting one resistance until the voltage across it is the same as that across the other resistance, both biases being the recommended values. In general, the resistances will be unequal approximately to the degree that the currents were unequal, but in the opposite direction.

### By-Pass Condensers

Now the effect of the signal for a dynamically balanced input will be closer to the ideal, because a given voltage input, divided in half as it is by any full-wave system, causes the same absolute quantity of change in the bias on one side as on the other.

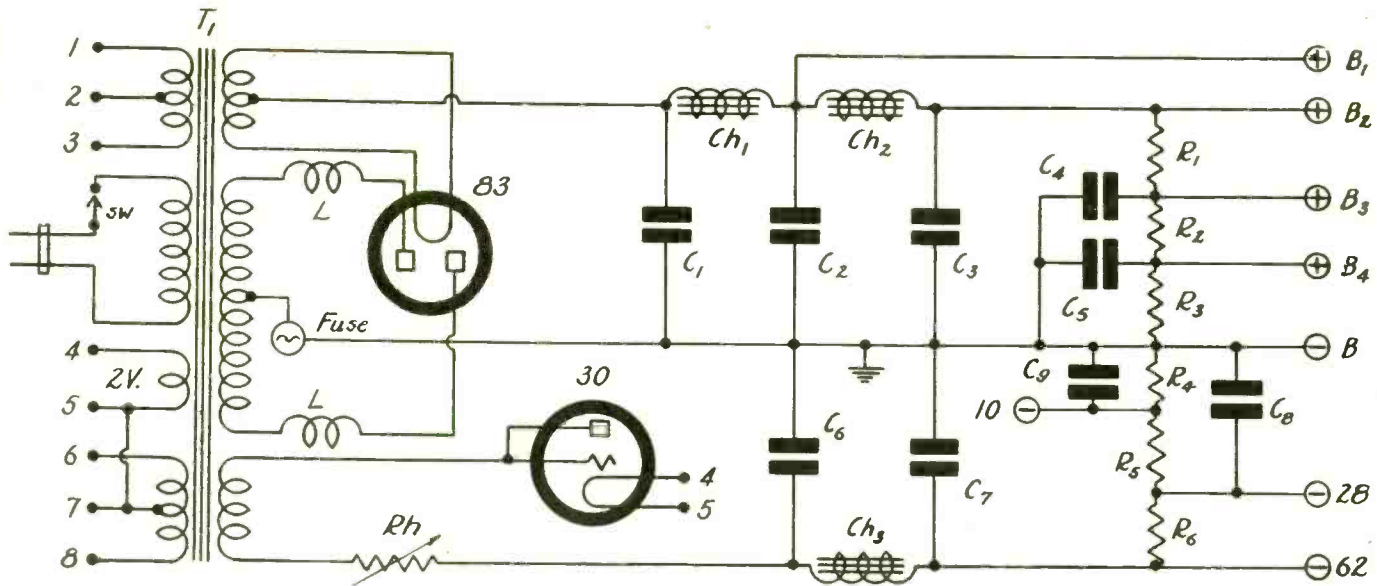

The use of fixed bias, rather than the self-bias shown in the other diagrams, is best for quality. Also, the power output capabilities are lifted somewhat. The way to have fixed bias is to use batteries or a C-supply rectifier. The diagram shows B and C rectifiers, the C tube being a 30.

The bypass condensers C1 and C2 are necessary, because at all times when there is a signal there is signal current through both resistors, for the cancellation of signal current due to use of a common resistor with currents 180 degrees out of phase does not exist then.

Not only does the general performance improve when the bias effect is equalized but also the hum is less. There has been some trouble due to hum in 2A3 circuits due to just such unequal effect or unbalance as described, and the reason is not far to seek, when we recall again the enormous mutual conductance of this husky tube.

In considering the voltages for any use of the 2A3's, in Class A or Class AB, it should be remembered that E1 is the self-bias voltage for the grid, negative to the left, positive to the right; E2 is the positive voltage for the plate, measured from cathode tap to B plus, and that the so-called "plate voltage" as considered by many a misnomer, is the total B voltage in reality, divided for positive plate and negative grid purposes, this B supply voltage being the sum of E1 and E2, and being shown by the arrows as E3. Only in rare instances, therefore, may the plate voltage be measured between plate and ground.

### Harmonic Distortion

The filament tap is the datum for a-c operation, although the negative filament is the reference point for d-c., of small consequence regarding plate voltage, but of some consequence in determination of the bias. The grid voltage values are specified from midpoint of the filament for a-c operation, so the 45-volt negative bias, or 62-volt negative bias (first for Class A, other for Class AB) are as stated. For battery operation of the filament half the filament voltage may be added to the bias specified for a-c operation, although it is not to be assumed there will be much direct-current use of output tubes requiring 5 amperes at 2.5 volts, or 12.5 watts filament power.

The Class AB operation of the 2A3's at fixed bias and the same class operation of the 42's at self-bias, at about the same plate voltages, give 15 watts output, fully realized when the driving is adequate.

With fixed bias the 2A's in Class AB provide 15 watts at only 2.5 per cent. total harmonic distortion, whereas the 42's or 2A5's in Class AB (triode connection, plate tied to screen) produce 5 per cent. total harmonic distortion (self-bias). The 2A3's Class AB, self bias, have 5% distortion, too. The power economy in the plate side is 50 per cent. better for the smaller tubes, and on the heater-filament basis the economy is about one-third better for the smaller ones, but when it comes to the utmost in quality, the 50 per cent. improvement in harmonic distortion elimination makes up for all of the other economy, and more.

### Test for Condenser

For any push-pull use the bypass condenser across the biasing resistor common to the two tubes should be tested. For Class A service in general it has been found this condenser may be omitted. Conditions of unbalance dictate the inclusion. So put the condenser across, and if the quantity of sound output is greater, and quality better, with the condenser in circuit, leave it there, otherwise omit it. For the 42 and 2A5 Class AB use it has been found that the condenser ordinarily has to be included for the circuit as shown, and should be as large as possible. An electrolytic condenser of 30-volt rating, 50 mmfd. capacity, is inexpensive, compact and adequate.

The negative bias for these tubes—2A5's or 42's in Class AB service—should be 38 volts, and the plate voltage 350 volts. For the 2A3 case of Class A, the plate voltage may be 300 volts and the negative bias 62 volts.

Fixed bias is recommended one for best quality, and this form of bias may be supplied by batteries (which last as long as their shelf life, as no current is drawn for the biasing purpose), or by use of a C supply rectifier and filter circuit. The rectifiers are shown in a special circuit, with a 30 tube as C-supply rectifier, the choke being small, filter capacities 1 mfd., and the bias adjusted by Rh, a 50,000-ohm rheostat. Let the C supply rectifier tube go dead sometime, as tubes will, and leave the power tubes unbiased, a fuse is put in the common plate return of the power tubes, and may consist of a small radio-type pilot lamp.

## Cities and States Extending Police Radio Systems

Washington. Another special use for radio communication apparatus has been adapted to the purposes of the dams in the western part of the United States. KIIW and KIIIX are now under construction in California in conjunction with the work of the San Gabriel Canyon Dam and the Tujunga Creek Dam, respectively.

The Maryland State Department of Forestry apparently proposes to equip its forest ranges with radio communication facilities, since it has applied for permission to construct radio transmitting stations at Burtonville, Md., and Hillemeade, Md., in addition to a portable. These transmitters are proposed for the frequencies of 31600, 35600, 38600, and 41600 kc, with a power of 50 watts.

One of the latest municipalities interested in police radio is the city of Bristol, Va., which has applied for permission to construct a transmitter for the frequency of 2470 kc, with a power of 50 watts.

The State of Washington has decided that its police activities would be materially aided by radio and so is interested in constructing five mobile radio transmitters for a frequency of 2490 kc with a power of 10 watts and with the installation of radio equipment at the following fixed points, Alpowa Camp, Ilwaco, Hells Crossing Camp, Satus Pass Camp, Yakima, Vancouver, and Walla Walla, in the state of Washington.

Even the relief bureau attests to the value of radio! The Westchester County, N. Y., Emergency Work Bureau has been granted six construction permits to build a similar number of experimental stations of 2 watts power for the frequencies of 31600, 35600, 38600 and 41000 kc.

### LITERATURE WANTED

V. H. Salvail, 1428 Harrison Ave., Butte, Mont.  
 Alan B. Staiger, 110 S. Vassar Sq., Atlantic City, N. J.  
 B. G. Swanson, Route 1, Des Moines, Iowa.  
 Eugene Valias, 15 Walton St., Suite 2, Boston, Mass.

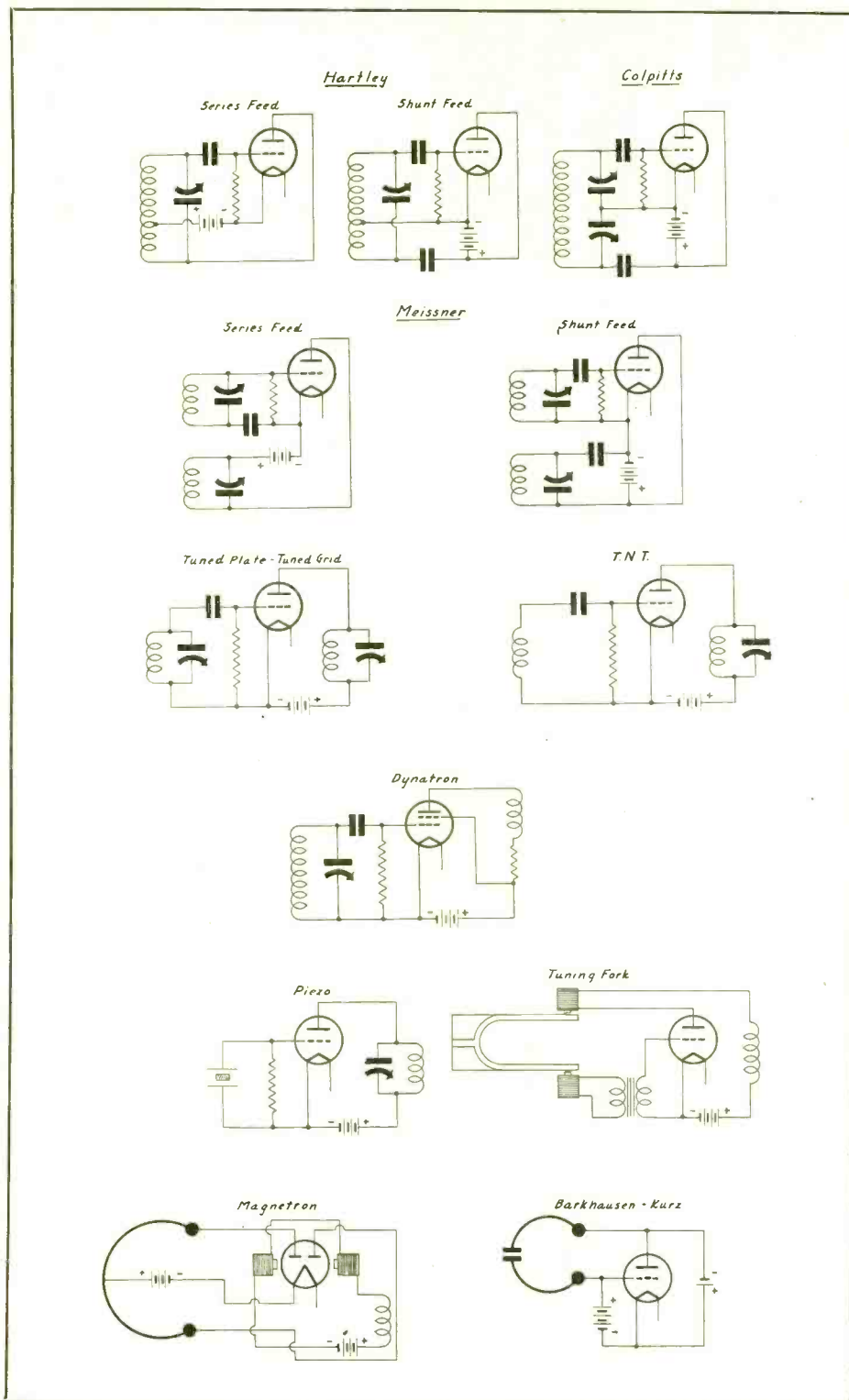

The foundation of modern radio transmission is laid upon the vacuum tube oscillator which is used to generate the carrier wave upon which the modulation is impressed. Any one of the indicated circuits might be used for this purpose.

**I**N utilizing radio for communication purposes it is necessary to generate an alternating current of high frequency so that the signal may be radiated most efficiently.

In the early days of radio these generators took the form of some sort of spark apparatus which produced a current that could be radiated. The inherent broadness of such waves soon rendered them unsuitable because of their interfering nature. New means of generating radio frequency currents were investigated. The results of various inventors led to the arc and Alexanderson

alternator principles which were decidedly instrumental in minimizing this broad characteristic of radio signals and thus represented technical improvements compared with waves generated by spark transmitters.

However, the arc and alternator oscillators were very cumbersome and required a great deal of heavy, expensive equipment.

#### DeForest's Audion

At this stage Lee DeForest introduced his audion or thermionic vacuum tube,

# OSCILL

## How to Distinguish mental Circuits- Ranges

By C. K.

which soon was applied to the function of generating the carrier frequency oscillations. The sharp characteristics of the wave generated by a vacuum tube oscillator and the compactness of the associated equipment render the tube most suitable for the purpose.

The production of oscillation by a vacuum tube oscillator is accomplished by so arranging its circuit that an alternating current in the grid side will be built up by an alternating current in the plate side so that the output circuit will be supplied with a continuously oscillating current. This is achieved by coupling the grid input circuit to the plate output circuit.

#### Distinguished by Coupling

The different methods possible for coupling purposes form the basis of the different oscillator circuits. Thus, the Hartley method of coupling is conductive, the Colpitts method is capacitive, the Meissner method is inductive. These circuits may be compared in this aspect by reference to the diagrams. It will be seen that they differ practically in only one respect, the manner in which coupling is accomplished. The correct choice of a desirable circuit for oscillator purposes will depend on the circuit requirements.

The current in an oscillating circuit reacts on the grid so that the voltage across the grid is changed. This grid voltage change, of course, will affect the plate current, which in turn acts upon the oscillating circuit to increase the oscillations. This action continues until the damping factors of the circuit, such as losses due to radiation and heat, cause a balanced circuit condition to be reached.

#### Amplitude Relatively Constant

Thus the amplitude of the oscillations are maintained at a given amplitude for given frequency and other constants. This state of constant amplitude can be attained by feeding a portion of the plate oscillations back into the grid circuit so that the losses are replaced. This relation between the grid and plate circuit is necessary so oscillations of a relatively steady amplitude may be generated. Special treatment, called frequency stabilization, which is tantamount to amplitude stabilization, is necessary for absolute stability.

Thus, the different relationships—conductive, capacitive, and inductive—form the basic differences between the various types of oscillating circuits that have been introduced.

# ATORS

the Different Funda-  
-All Frequency  
Covered

*Biddel*

In the various oscillator circuits shown the coils and condensers are so chosen that their resonant frequency is the natural frequency of the oscillator circuit itself. To achieve this objective, either the condenser or the coil or both are made variable so that the frequency adjustment may be made readily.

Another important requirement is that the coupling be in place so that the building up action that is necessary will ob-

Otherwise degeneration would be introduced. Thus, the degree of coupling between the plate and grid circuits may be substantially varied so that just the small amount of feedback necessary to maintain oscillations of constant amplitude may be achieved. It has been found weak coupling is consistent with best stability.

## Negative Resistance

The first disturbance in the circuit might be caused by a movement of electrons in the tube as a result of change in capacity in the circuit or because of the flow of a small current in the circuit, when the operating potentials are applied. The weak oscillations that are thus formed by the application of electrode potentials will induce an oscillating voltage in the tank circuits which will be built up as outlined above until the point of saturation is reached, when oscillation will maintain itself at steady value.

In an ordinary oscillating circuit, the rate of energy consumption is proportionate to the circuit resistance. Where the circuits utilize a vacuum tube, as those described in the diagrams, the tube output will feed energy back into the input circuit to replenish the loss. This feedback action overcomes the resistance losses of the circuit in this way and may be looked upon as a negative resistance since instead of causing an energy loss it produces an energy gain. When this negative resistance is less than the circuit resistance, the oscillations will die down quite rapidly.

## Control of Coupling

If the negative resistance is greater than the circuit resistance, the oscillations will become stronger until the saturation point of the tube is reached. It is therefore said that the oscillation intensity is limited by the curvature of the characteristic, but this is not strictly true, otherwise a linear oscillator could develop infinite amplitude, which is in a class with perpetual motion.

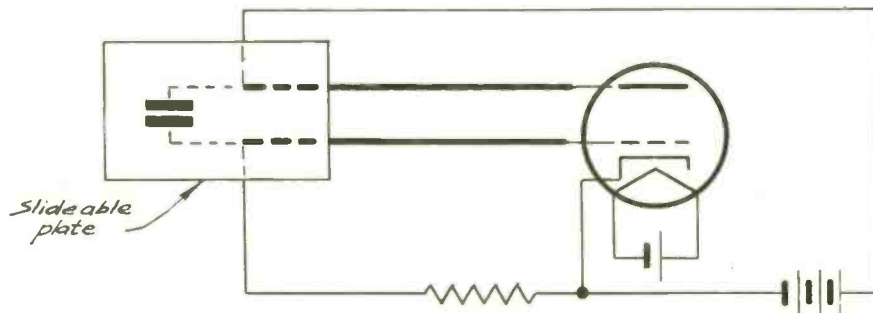
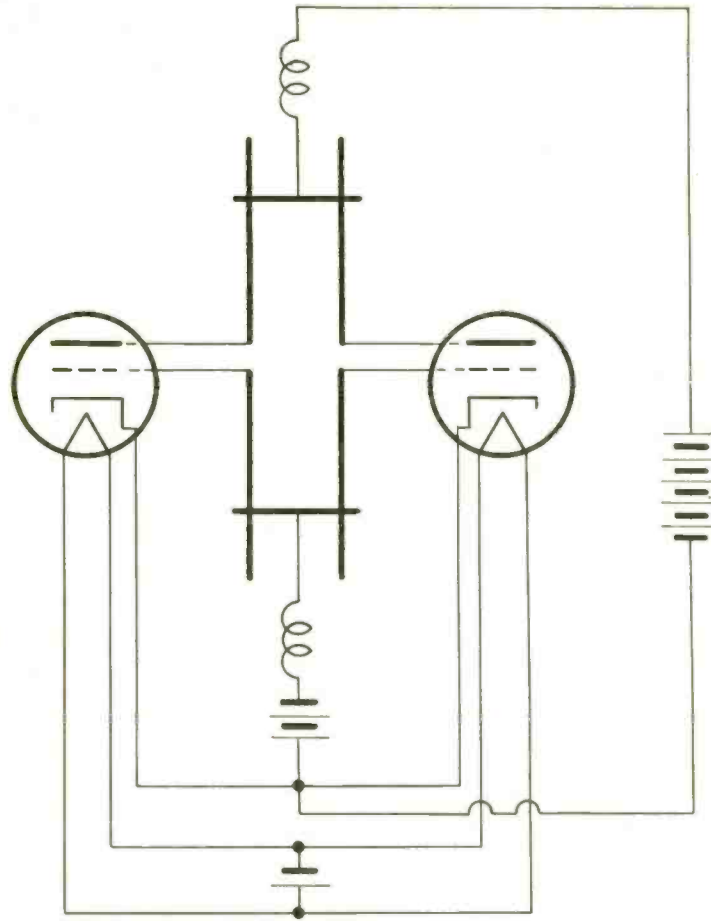

Two oscillators for the ultra high frequencies.

In the saturation state of the tube self-oscillation exists and is usually disadvantageous. Therefore the feedback adjustment of an oscillator should be maintained so that the negative resistance is practically equal to the circuit resistance whereby continuous oscillation of fixed amplitude will ensue.

The control of this negative resistance effect is nicely achieved by variation of the coupling between the input and output circuits which is done in different manners according to the circuit: in Hartley by means of an inductance tap, in the Colpitts by means of two condensers, in the Meissner by means of the induction between two coils. This controllability varies between the saturation value and the zero region of the tube.

## A Different Way

Since the plate current cannot go beyond the saturation point, a further change in the coupling in the same direction will cause a decrease in the grid circuit so that the oscillation will stop. Therefore for most stable oscillation, it is essential that the correct adjustment

of input and output voltages be made by means of the coupling between the two circuits to a point inside these two limits.

In the Hartley, Colpitts and Meissner circuits the manner in which feedback of energy is achieved is readily apparent from the foregoing data. However, in the tuned plate-tuned grid circuit, the action is different. Here the tuning tanks are not mutually related in any way and it might be wondered how the feedback occurs. If the two tank circuits were related inductively we would have the Meissner circuit. But there is no induction between the plate and grid tanks. However, oscillation will not occur unless the circuit can feed part of the output energy back to the input. This is accomplished through the inter-electrode capacity of the tube, and thus the method is differentiated from the Meissner circuit.

It is obvious from this fact that the inter-electrode tube capacity is an item to reckon with when this circuit is used.

The next circuit, the T. N. T., is an adaptation of the T. P.-T. G. circuit as its only difference is that the grid circuit is untuned. This obviates the necessity for an additional adjustment and in some instances, where economy is a factor, mini-

*(Continued on next page)*

# An Insight into Oscillating Circuits

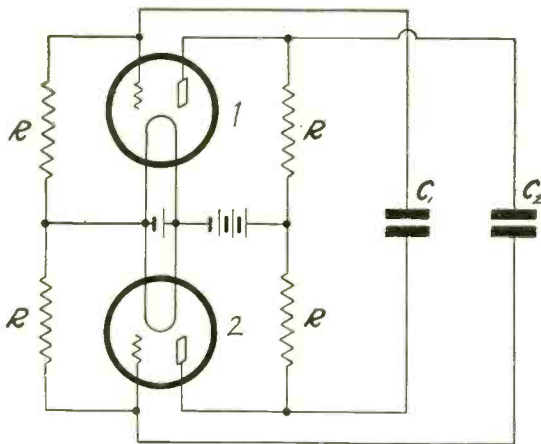

Multivibrators are oscillators that are rich in harmonics.

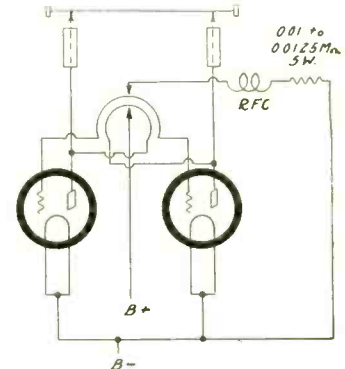
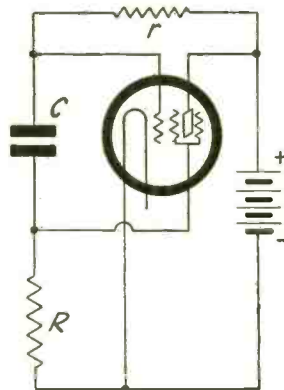

A push-pull circuit for ultra-high frequency work.

(Continued from preceding page)  
mizes expense by confinement to a single tuning condenser.

### Dynatron and Others

The Dynatron oscillator utilizes a four electrode tube wherein the screen grid is maintained at a higher positive potential than the plate, which, due to the tube geometry, results in the negative resistance characteristic that is essential for oscillating conditions.

The piezo oscillator does not utilize the feedback principle but rather depends upon what is known as the piezo-electric effect. This effect is noticeable when crystals or minerals, such as quartz and rochelle salts, are subjected to an electric potential. Under this condition, these crystals will vibrate at a frequency determined by their physical size. Thus, this vibration may be made to affect the

grid circuit of a vacuum tube whereby the plate circuit will maintain oscillations of the same frequency but of greater magnitude. In this manner substantially stable oscillations at a frequency fixed by the size of the crystal will be generated.

The tuning fork oscillator functions in similar manner to the piezo oscillator as the fork's vibration causes the induction of a similar frequency oscillation in the plate circuit of the oscillator tube. This oscillator is utilized for the audio frequency range only, however.

### The Magnetron and B. K.

The last two oscillators have been specially developed for the generation of ultra-high frequency waves and as such dispense with extra tuning capacities and use the tube capacities themselves for this purpose. The inductances used at these frequencies usually consist of a very few

turns of wire on a small diameter form, or one large turn, as shown.

The magnetron oscillator depends for its oscillation on the principle that a powerful magnetic field acting upon a stream of electrons will so affect them that they will be rendered capable of oscillation at high frequencies. On the other hand, the Barkhausen-Kurz oscillator depends for its action upon the fact that the very high positive potential upon the grid and the negative or zero potential on the plate will cause the electrons to be attracted to the grid rather than to the plate. However, since the grid is full of empty spaces through which the electrons may be able to pass because of their high velocity, most of the electrons will pass the grid and move towards the plate. The negative charge on the plate will repel them and the electrons will be forced to return towards the grid. This action will cause an oscillation of the electrons around the grid at a frequency dictated by the velocity of the electrons rather than by any inductance or capacity in the circuit. Since the velocity of the electrons is determined by the grid and plate potentials, this frequency is determined by these voltages, in the last analysis.

Sometimes it is desirable to construct an oscillator rich in harmonics. An example of such an application is in the measurement of frequencies of a great number of stations on different channels. It is here that the multivibrator finds its utility since that device performs this function admirably. Two types of multivibrator circuits are shown in the sketch.

In the last sketch is shown an adaptation of the standard oscillator circuits to the ultra-high frequencies. Here capacities are dispensed with and the capacity of the tube elements alone are utilized for the purpose of frequency control.

It will be seen from this brief discussion that in reality there are only two basic types of oscillators: those of frequency determined by the inductance and capacity in the circuit and those of frequency determined by the velocity of the electrons within the tube. However, the electron type of oscillator is a relatively new development and is only utilized at the ultra high frequencies because of the high speed of an electron. For the lower frequencies, the inductance-capacity oscillator is used.

### USES OF MULTI-ELEMENT TUBES

There are two general uses for multi-electrode tubes: (1) to perform some function that cannot be performed by a triode, and (2) to perform the work of two triodes.

## Two Almost for One

Radio World is \$6.00 a year (52 issues). Read the following Combination Offers for Radio World and other worth-while publications for one full year on each offer.

- RADIO WORLD and SHORT-WAVE CRAFT, \$7.00.
- RADIO WORLD and POPULAR SCIENCE MONTHLY \$6.50.
- RADIO WORLD and RADIO-CRAFT (monthly, 12 issues) \$6.50.
- RADIO WORLD and RADIO INDEX (monthly, 10 issues), stations, programs, etc., \$6.35.
- RADIO WORLD and RADIO (monthly, 12 issues; Short Wave and Experimental) \$6.60.
- RADIO WORLD and EVERYDAY SCIENCE AND MECHANICS (monthly) \$6.50.
- RADIO WORLD and RADIO LOG AND LORE. Bi-monthly; 5 issues. Full station lists, cross indexed, etc., \$6.25.
- RADIO WORLD and SERVICE (monthly), 12 issues, \$7.00.
- RADIO WORLD and AMERICAN BOY - YOUTH'S COMPANION (monthly, 12 issues; popular magazine) \$6.50.
- RADIO WORLD and BOYS' LIFE (monthly, 12 issues) \$6.50.
- RADIO WORLD and MOTION PICTURE MAGAZINE (monthly) \$6.50.
- RADIO WORLD and MOVIE CLASSIC (monthly) \$6.25.
- RADIO WORLD and SCREENLAND (monthly) \$6.50.
- RADIO WORLD and SILVER SCREEN (monthly) \$6.25.
- RADIO WORLD and OUTDOOR LIFE (monthly) \$6.50.
- RADIO WORLD and THE PATHFINDER (weekly) \$6.25.
- RADIO WORLD and TRUE STORY (monthly) \$6.50.
- RADIO WORLD and LIBERTY (weekly) \$6.50.

Select any one of these magazines and get it for an entire year by sending in a year's subscription for RADIO WORLD at the regular price, \$6.00 plus a small additional amount, per quotations above. Put a cross in the square next to the magazine of your choice, in the above list. Fill out the coupon below, and mail the quoted price by check, money order or stamps to RADIO WORLD, 145 West 45th Street, New York, N. Y. (Add \$1.50 for extra foreign or Canadian postage for both publications.)

Your Name.....  
 Your Street Address.....  
 City..... State.....

**DOUBLE  
VALUE!**

- If renewing an existing or expiring subscription for RADIO WORLD, please put a cross in square at beginning of this sentence.
- If renewing an existing or expiring subscription for other magazines, please put a cross in square at the beginning of this sentence.

**RADIO WORLD, 145 West 45th Street, New York. (Just East of Broadway)**

# High Output from Small Tubes

## 42 or 2A5 Class AB Provides a Solution

By Henry L. Woods

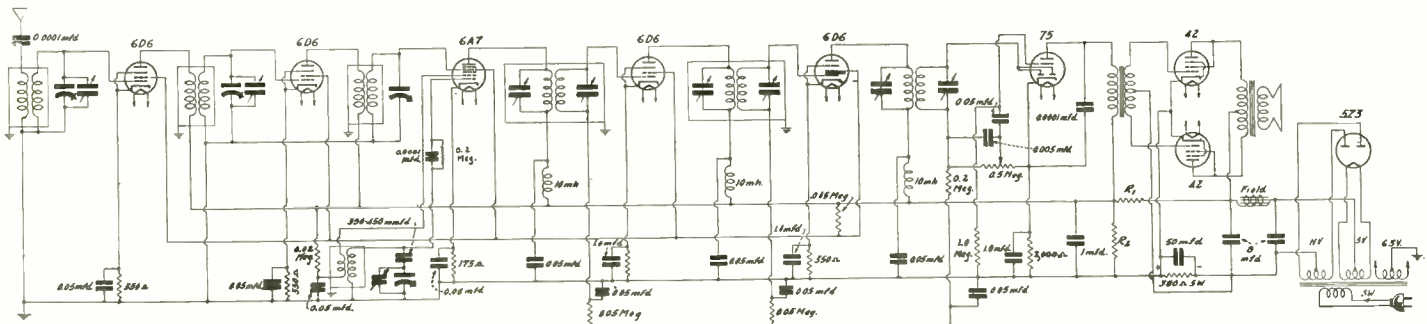

The use of 42 tubes in Class AB output is shown in this diagram of a broadcast superheterodyne. Depending on voltages and biasing methods, 15 to 18 watts output may be obtained. In the circuit shown the voltage from plate to cathode of these tubes should be 350 volts, the bias voltage 38 volts additional. Improved pentagrid tube use and tone compensation for low volume settings of the volume control are featured also. R1 and R2 are selected to drop the B voltage to 250 volts.

USE to which 42 output tubes may be put, not usually shown, is that of a push-pull Class AB output stage. This tube is of the heater type, 6.3-volt series, and therefore may be fed by the same secondary that supplies the other tubes of the same series in the set. The 42 is the 6.3-volt equivalent of the 2.5-volt heater type 2A5. When either of these tubes is used with fixed bias the output rating is 18 watts, and with self bias is 15 watts. The device used for biasing the broadcast superheterodyne shown is semi-fixed bias. The negative bias should be 38 volts, and it is assumed the total B current is 100 milliamperes. Hence 380 ohms are used for biasing.

Although the 42 tube, like the 2A5, is a pentode, it is constituted as a triode, or three-element tube, since the plate and grid are tied together, and thus the suppressor effect is obliterated, because the suppressor in pentode use is between the plate and the screen. The potential being the same on plate and screen, the suppressor effect is lost, but is not needed in this triode use.

### Small No-Signal Plate Current

The plate current per tube is 21 milliamperes, which is exceedingly small compared to what exists for similar output with triodes as normally found. Nevertheless the circuit shown is high-powered, and therefore the total B current is appreciable, and the high-voltage winding of the power transformer should have a 120-milliamperes rating. This means the winding will stand 120 milliamperes without heating much. It is better to play safe with these commercial estimates, for the total current through the winding will be around 100 ma.

The heater type output tube helps reduce hum, and since the circuit has the cathodes of the output tubes grounded, and bias applied by grid returns to a more negative point of the B line, the hum is kept extraordinarily low. But the push-pull input transformer should be as far as possible from the power transformer, to effectuate a complete hum cure in conjunction with a standard filter.

This means the input transformer should be on the radio-frequency side of the usual chassis layout, which is the op-

posite end to the one where the power transformer is found. Unless this precaution is taken it is almost impossible to get the hum level at that very low value that experimenters appreciate so much.

### These Long Leads Don't Matter

It does not matter that long lead have to be run to and from the input transformer, as these leads carry audio-frequency currents only, and the frequency difference is too great between these currents and the radio-frequency currents to have any objectionable coupling arise this way.

It is not well to use a resistor-capacity filter in the 75 plate circuit to keep the d.c. out of the primary of the input transformer, because with the current through the primary more power is available for the output tubes, and they do on occasion require some driving power. In fact, if more than 15 watts output is to be obtained the driver would have to be a huskier tube, say, another 42 used as a triode. The 75 triode is a compromise, sufficiently within the requirements to yield satisfactory performance. It is not assumed that for home use any tax on an output stage equal to 15 watts regularly will be imposed, as 5 watts happen to be all-sufficient, and whatever extra there is may be explained as being there for those sudden occasions when an extra-heavy demand is made on the output because of some crescendo of a symphonic orchestra or the heated emphasis of some speaker whose amplitude of voice may be as various and conflicting as his arguments.

### Tracking Data

Aside from the output tube the circuit subscribes generally to designs with which readers are quite familiar. The superheterodyne has two stages of pre-selection, a tuned input to the modulator (control grid of the 6A7 pentagrid converter tube), and a tuned oscillator, padded for 465 kc. Commercial coils may be used, the inductances being 230 microhenries for the secondary, primaries according to choice, and oscillator secondary 110 microhenries. With his proportionality of inductances of secondaries, and with a 350-

450 mmfd. padding condenser, tracking will be good.

The oscillator section has slightly different constants than usual. The grid condenser is 0.0001 mfd., smaller than standard, the leak is somewhat higher, 0.2 meg., and the return is to ground. Besides, the leak-condenser connection is in series. This permits a much higher input impedance. Moreover, grounding the leak return, which is done through the secondary winding, accelerates the oscillation a bit, due possibly to the fact that there is a voltage difference between leak-condenser action detection and the static bias condition. In other words, the grid is not returned to the cathode, for zero bias at no signal, during the fragmentary period of non-oscillation, when the wave is on the zero axis, but the grid is returned to a negative potential, and the oscillation amplitude has to equal the static bias before any grid current flows. Hence with less grid current, or retarded grid-current action, there is less power required to actuate the leak, and all forms of power derivation are at the expense of input impedance in this circuit.

### Intermediate Stability

The intermediate amplifier is subjected to automatic volume control. This is ample to keep the output voltage fairly steady no matter what the antenna input. Whenever automatic volume control is included the filtration has to be heightened, because the control circuit offers a coupling path not completely eradicated under with any usable constants. If the bypass condensers across the biasing resistors are large enough there should be no trouble from i-f oscillation. The value shown is 1.0 mfd. for this purpose but under some circumstances would have to be doubled.

The manual volume control in the diode-triode circuit of the 75 has a condenser of 0.005 mfd. from potentiometer arm to negative side of this second detector. The reason for this condenser is that when the load impedance is low for the grid of the triode the low notes are severely attenuated. That is, low volume settings introduce distortion. The condenser remedies this, because the lower the volume setting the more effective the capacity in bypassing the high audio tones, therefore bringing out the low notes by comparison.

# Capacity Bridge Circuits

## Various Methods of Measuring Condensers

By M. K. Kunins

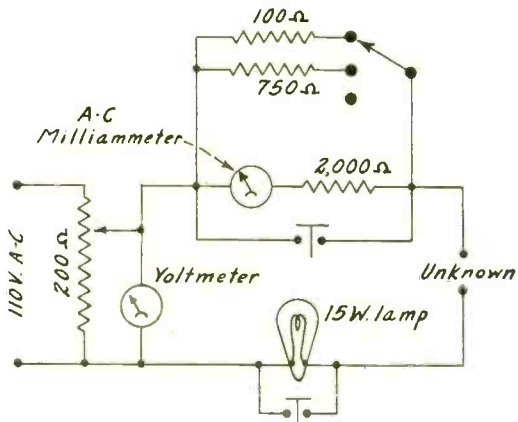

Use of a-c milliammeter.

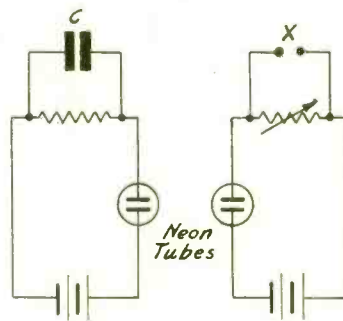

Visual neon comparison.

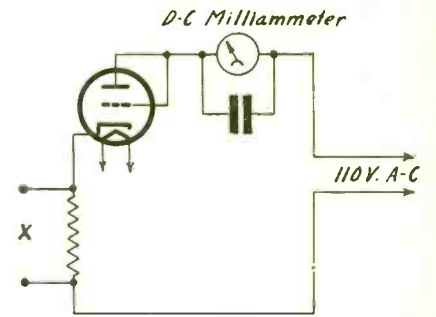

The by-pass effect.

(This is the second and concluding instalment of the capacity measurement article.—EDITOR.)

IF the incandescent lamp lights immediately, concrete indication is present that the condenser under test is shorted and no further tests need be made. If the lamp does not light immediately, then the condenser is not shorted and the test may proceed. This is done by depressing the lamp switch which shorts it out of the circuit, and keeping it depressed for the rest of the measurement. The switch across the milliammeter should now be released. If the meter reads more than 0.1 milliamperes, the reading should be noted and the corresponding capacity noted from the graph directly. If the

meter reads less than 0.1 milliamperes, then the range switch should be moved to Range 2, and the meter read again. If the reading is still too small, Range 3 should be utilized. In any event, the capacity is always determined by reading from the graph the capacity in microfarads corresponding to the meter deflection and the range used.

### An Added Attraction

For example, suppose that a condenser was being tested and it gave a reading of 0.5 milliamperes on Range 2. Then from the graph, the capacity of the meter must be 0.131 microfarad. If, on the other hand, the reading was 0.8 milliamperes on Range 1, then the capacity would be 2.1 microfarads.

The instrument can be made somewhat more foolproof and simpler in operation by combining the meter switch and the lamp switch into one switch that will accomplish the same action by one push button. In this type of switch the normal position would be such that the lamp switch would be open and the meter switch would be closed. Then if the condenser has been placed across the test terminals, and the lamp does not light, the switch button can be pressed, which will cause the switch across the lamp to close and the short circuit switch across the meter to open. In this manner it would be impossible for the operator to leave the meter switch open which would result in a burn out of the meter if a shorted condenser was placed across the terminals.

The type of capacity meter described herein differs from other types of test meters in that essentially uniform scales are obtained which is not the case in ordinary types of instruments which use a resistance to safeguard the meter from damage, an advantage from this viewpoint, but a disadvantage from the standpoint of scale uniformity. Furthermore, this instrument is not presented as one that is designed to furnish accurate measurements of condenser capacity but rather as a means to permit the determination of condenser capacity within what are in most cases commercial tolerances. The errors involved are too large—the rectifier type of meter alone has an error at full scale deflection in the order of 5 per cent—for accurate work. But in most cases service work requires the determination of what we might call the nominal capacity and the meter should prove effective for that purpose.

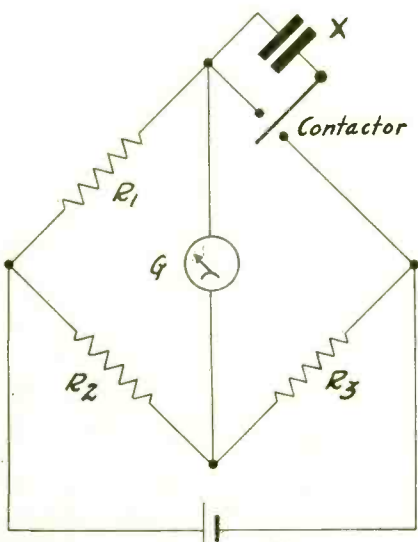

$$X = \frac{R_2}{n R_1 R_3}$$

(*n* = Contactor Speed)  
Maxwell's Capacity Bridge

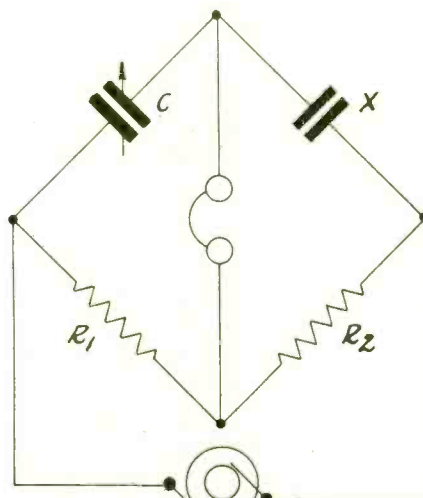

$$X = \frac{C R_1}{R_2}$$

DeSauty Capacity Bridge

Two standard circuits of the bridge type that can be utilized in the measurement of capacity.

### Neon Tube Method

Sometimes the necessary a-c instruments are not available or the experimenter is financially unable to indulge in such luxury. In such a case, a neon tube might be utilized. In this arrangement, as depicted in the center sketch, two neon tubes are connected in similar circuits involving a resistor capacity shunt in series with the neon tube and a battery.



The combination of the resistance and condenser serves to cause the neon tube to flicker at a definite frequency dependant upon the constants of resistance and capacity. This frequency will be proportional to the product of the resistance and the capacity. If then the constants of both circuits are so adjusted that the flickering of both neon tubes are in phase, it can be said that the resistance capacity product of one circuit is equal to the resistance capacity product of the other. Since one circuit consists of standard known resistance and capacity and the other contains a known resistance, it is possible to solve for the unknown capacity:

$$C_x = \frac{C_1 R_1}{R_x}$$

Although this method is quite approximate, it satisfies sufficiently well the purposes of most service problems where it is merely desired to ascertain whether a certain condenser is at all near its rated value.

**Series and Parallel**

Another very approximate method may be built out of the arrangement shown in the sketch at the right. Here the effect of different sizes of condenser across a cathode bias combination of an a-c tube will be ascertained by the plate milliammeter which may be of the d-c type. This method may be substituted when appropriate a-c instruments are not handy but one of the d-c type is.

In closing, it might be indicated that the ranges of all these instruments may be made more elastic by connecting the unknown condenser in series or in shunt with a known standard condenser according to the size of the unknown capacitor. The capacity of the two condensers is then measured. Since the standard condenser's capacitance is known, it is possible to derive the unknown's magnitude by simple arithmetic associated with series and parallel circuits:

If in series,

$$C_x = \frac{C_1 C_x - C_{tot} C_1}{C_{tot}}$$

or if in parallel,  $C_x = C_{tot} - C_1$  where  $C_x$  is the unknown capacity,  $C_1$  the capacity of the standard and  $C_{tot}$  the total capacity of the combination.

**Capacity Bridges**

It might be apropos for the sake of an attempt at completeness to mention two types of capacity bridges that have been used for many years in capacity measurements. These bridges were devised by that prolific electrical theoretician, Maxwell, and by DeSauty. The essential point of interest in these bridges is that an alternating voltage is impressed across a bridge arrangement of two resistances and two capacities. Variation of the two resistances and the one known standard capacity until zero effect is produced in the phones or on the galvanometer indicates that a state of balance has been secured from which condition, the value of the unknown capacity may be calculated from the fact that the various units will be proportional to each other according to the formulas indicated under the respective sketches.

Since everyone who has ever constructed a piece of radio equipment has been more than once been obliged to wonder whether a certain condenser will be suitable for a certain purpose, these capacity instruments should be of great utility to all radio enthusiasts and should furnish the necessary answer in cases of capacitive uncertainty.

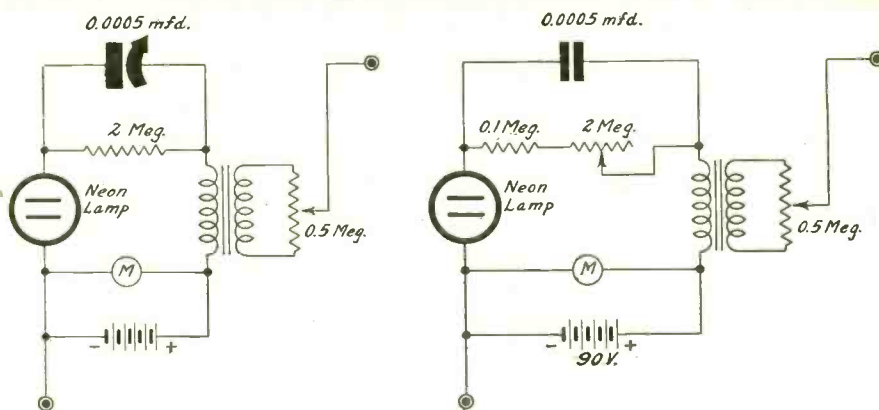

Since the frequency generated by a relaxation oscillator depends on capacity and resistance, if the resistance is fixed and capacity varied, the capacity can be measured in terms of frequency. At right, resistance measurement.

**READY REMEDIES**

By Ingenious Readers

[Any who have discovered short cuts, cures or economical practices are invited to send in their reports so other readers may share the benefits, the contributors deriving the advantages that other readers have recorded this way.—EDITOR.]

Many radio fans with proclivities in the a-c supply direction are troubled with hum that creeps in from nowhere, or so it seems to them. They have fretted to no avail. They have changed rectifier tubes, filter chokes and condensers, investigated grounds or other leakage and still the hum persists.

LaVerne G. Scheffler, of Shillington, Pa., has been subjected to this annoyance and used his head in finding the cause of his dejection. He found that the hum he heard was caused by the fact that his audio frequency transformers were too close to his power transformer. This resulted in an induction of the a-c field around the power transformer into the audio frequency transformers to produce a beautiful hum. Mr. Scheffler put one

earphone tip to a "hot" side of the audio transformer, other lead free, and heard the hum. Then he moved the audio transformer until hum disappeared.

Of course, a relocation of the audio transformers, out of the field of the power transformer, produced the calm and quiet that was desired.

\* \* \*

C. F. Morgan, of College Park, Ga., states that he has found that a lead-in wire from his antenna of small size, of the order of No. 30 wire, does not materially affect his results so that he does not suffer the drafty effects of an incompletely closed window that results from a larger lead-in wire.

\* \* \*

Effacement of squeals due to oscillation at the radio-frequency level of a superheterodyne, but applicable also to tuned r-f sets, was accomplished by R. B. O'Connor, 30 Ninety-first Street, Brooklyn, N. Y., by connecting the cathode return of the first circuit through a 10,000-ohm variable resistor to antenna, whereby the return was made through the coil to ground, adjusting the resistor until the squeal disappeared at 1,500 kc for the broadcast band, measuring the amount of resistance that created the remedy and replacing the variable with a fixed resistor of that value.

**Range of Audio Frequencies**

Cycles p. s.	Remarks
32768	Beyond limit of audibility for average person.
16384	Telephone silent with 40 volts on receiver terminals.
10000	Considered upper limit for nearly perfect transmission of speech and music.
8192	Highest note on fifteenth stop on an organ.
5000	Considered as satisfactory upper limit for good quality transmission of speech and music.
4096	Highest note on piano.
3000	Considered acceptable upper limit for the transmission of speech.
2560	Approximate resonant point of ear cavity.
2048-2000	Maximum sensitivity of the ear as whole.
1500	Mean speech frequency from articulation viewpoint.
850	Representative frequency of speech as found in home and office telephone currents.
800	
426.66	Orchestra tuning frequency.
256	Considered as satisfactory lower limit for quality transmission of speech and music.
200	
80	Lowest note of average man's voice.
64	Lowest note on 'cello.
32	Lowest note on church organ.
30	Considered lower limit for nearly perfect transmission of speech and music.
27	Lowest note on piano.
16	Lowest audible sound.

HERE ARE WORTH-WHILE HOLIDAY GIFTS

# 1935 Model ALL-WAVE DIAMOND OF THE AIR!

TABLE MODEL

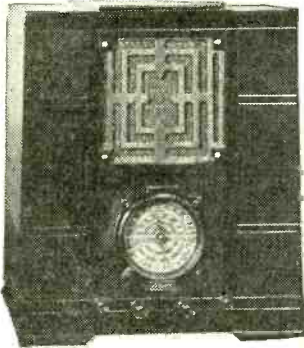
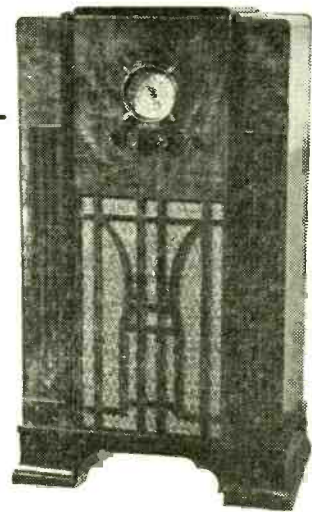

Table Model All-Wave Diamond, using the same 8-tube chassis and tubes as the console model. Wired, complete, with eight tubes. Shipping weight 28 lbs. Order Cat. 1008-T.

**8 TUBES!  
5 BANDS!  
A. V. C.!**

CONSOLE MODEL



The All-Wave Diamond, 150 kc. to 22 mgs. (2,000 to 13 meters), in its distinctive modernistic console cabinet of genuine burl walnut, curly maple front, artistically varnished overlays. Extra large baffle and powerful heavy-duty 8-inch dynamic speaker. Wired, equipped with following RCA tubes: one 6A7, two 6D6, one 75, one 76, two 42's, and one 80. Cat. 1008-CON. Weight, complete, 37½ lbs. For 50-60 cycles, 110 volts. Shipping weight, 5½ lbs. Net price, F.O.B. Sandusky, O.—\$45.57

**T**O get away from the conventional and ugly cabinets in which table model receivers have been housed in the recent and remote past we have just obtained an entirely new design, 14½ inches wide, 18 inches high, 9½ inches front to back, to house our 1008 chassis, the finest all-wave 8-tube superheterodyne receiver made. The performance is exactly the same, as between the console model and the table model.

The selection of one model or the other will depend considerably on whether you have some mantel or end table or the like on which you'd prefer to place a physically smaller cabinet (but the same-sized set), or whether you have the room for the large console, 21 inches wide, 36½ inches high, 12 inches front to back. We have gone to great pains to obtain two models that do not differ in performance, and that yield the maximum that radio has to offer to-day, so that space and artistic requirements can be met to the fullest, along with maximum performance.

The table model is Cat. 1008-T, shipping weight, 28 lbs., wired, in cabinet, complete with eight RCA tubes; net price (shipped from Sandusky, Ohio)—

**\$32.75**

The wired chassis, with speaker and tubes (no cabinet) can be purchased by any who care to use a cabinet they have. See price at right.

**W**HENEVER a person wants to buy a particularly fine receiver he usually feels he has to pay a particularly high price for it. Ask almost any one what kind of a set he would want and the answer would be: "An all-wave a-c set, of course." He might prefer a console model or a table model, but he would want band selection by switching. The only drawback, perhaps, is that, times not being so prosperous, he hasn't the price of such a fine instrument. But we point to something new and startling in radio merchandising—the production of a de luxe, superb all-wave set, 150 kc. to 22 mgs. (2,000 meters to 13 meters), at the inconceivably low prices of \$45.57 net for the console, and \$32.05 for the de luxe table model. These two cabinets are illustrated herewith, and the same superheterodyne chassis is used in both.

These prices are absolutely net, and represent complete wired receivers, equipped with RCA tubes throughout, and securely packed.

The low prices would not mean a thing unless these receivers were of first quality and excellence, unless they had great sensitivity and selectivity, so that foreign short-wave stations and domestic broadcasts could be tuned in with enjoyable volume and steadiness, and unless the tone was marvelous. These new DIAMOND OF THE AIR All-Wave Receivers, in the two models illustrated, are quality products of the highest attainment, enthusiastically indorsed by leading radio engineers, who blink with amazement when told the selling price, in view of the outstanding performance.

As a check on whether care has been taken to make this receiver outstanding, note that the low-frequency band is included. Now, an all-wave set may mean almost anything, but when you are told that the low-frequency extreme is 150 kc., and that the highest frequency tuned in is 22 mgs. (13 meters, mind you!) then you can realize that painstaking craftsmen spent long hours getting the instruments right, so that they would cover frequencies that sweep from one end to the other of program and other bands.

And there is sufficient overlapping between bands, as you turn the gentle band-selector switch, to prevent misout. And moreover, the programs come in with steadiness and clarity, for there is a highly-effective automatic volume control, to correct for fading and to prevent blasting when tuning from station to station.

Exceptional care has been taken in prevention of image interference, and the wisest experts who have given this receiver critical attention admit that the pre-selection is abundant.

Another interesting technical point: This set runs cool. The 8-volt series tubes are used—wise choice indeed—because the elements of these tubes are stronger than those of the 2.5-volt series, and the power consumption in the heater is considerably less. And yet there was no skimping. The primary power consumption is 80 watts.

Nor does the dial have mere arbitrary numbers on it. 0-100 for instance, as found on what we term "unfinished" sets. This receiver has the very latest illuminated airplane dial, with frequency calibration for each of the five bands, so is direct reading in frequencies, and besides has a double pointer so the benefit of wide spread-out on the scale is derived from both semi-circles. Close vernier tuning is provided.

There are a manual volume control and a tone control.

And the speaker? A heavy-duty 8-inch diameter-cone dynamic speaker that is a fitting climax to an expert design and assembly.

The 8-tube, high-gain, all-wave (150 kc. to 22 mgs.) Diamond of the Air wired chassis, 50-60 cycles, 110 volts; with the powerful dynamic speaker and the eight RCA tubes, may be purchased (no cabinet). Order Cat. 1008-CH. Net price, \$29.25

**\$45.57**

## 6-TUBE DIAMOND AUTO SET, \$23.95

**O**UR previous model Auto Set was so good that the model was not changed in three years. Now at last it has been improved upon, certain mechanical refinements introduced, and tubes of somewhat higher efficiency included. Some of these tubes were not manufactured until recently. Also the set now has a.v.c.

Our 1009 Auto Radio is a six-tube superheterodyne set, using one 6A7, one 41, one 75, two 78's and one 84, and tunes from 540 kc. to 1,600 kc. It is a one-unit receiver, ruggedly built for long life, and is equipped with a dynamic speaker. It has an illuminated vernier airplane type control. The manual volume control and lock are one combination. The power consumption is 4 amperes.

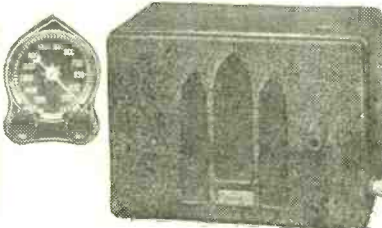

No B batteries required. There is a B-eliminator built in.

This is one of those fascinating auto sets that has single-hole mounting provision, and therefore is a cinch to install. There are only two connections to make: (1), to the ammeter; (2), to the aerial.

The remote tuner is, of course, supplied with the set. And the spark plug suppressors and commutator condenser are supplied, also.

The size is 8¾ inches wide, 6 inches high, 6¼ inches front to back. Shipping weight is 18 lbs.

Order Cat. 1009, wired, in cabinet, complete with six RCA tubes.

ALL OUR DIAMOND SETS EQUIPPED WITH RCA TUBES  
GUARANTY RADIO GOODS CO., 145 WEST 45th STREET, NEW YORK, N. Y.

# NEW ALL-PURPOSE ANTENNA COUPLER



**T**HE Bernard All-Purpose Antenna Coupler provides a noise-reducing method of connecting any type antenna to any type receiver.

The popular noise-reducing antenna systems, using transmission lines from doublet, can not be connected to most receivers, because most receivers have only one antenna post, the other post being ground, while the doublet's transmission line requires two antenna posts. The Bernard All-Purpose Antenna Coupler provides the necessary link between twisted pair, transposed dual leads, or other transmission lines of doublets, so that noise-reducing antenna system can be used on the set you have.

Besides, the Bernard All-Purpose Antenna Coupler is in itself a noise-reducing device, enabling quieter operation of the receiver, due to larger ratio of signal to noise.

The Bernard Coupler may be used with broadcast, short-wave and all-wave receivers, and requires no molestation of its connections.

The Bernard Coupler is built into a Bakelite moulded conical container.

The Coupler provides the necessary flexibility of connection to serve four purposes as follows:

(1)—Use of dual transmission leads from a doublet to a receiver equipped for doublet connection, that is, having two antenna posts. Connect doublet leads to the two press posts marked "Ant." Connect two tipped flexible leads supplied with the Coupler to the Coupler's two tip jacks, other ends of these leads to the two antenna posts. Disconnect the spade lug from the Ground post and ignore that post of the Coupler. A measurable reduction in noise will result.

(2)—Use of two transmission leads from a doublet to a receiver not equipped with two antenna posts (having only usual antenna and ground posts). Connect doublet leads to the two press posts marked "Ant." Connect one of the flexible leads from one Coupler tip jack to antenna post of set and other flexible lead from other Coupler tip jack to set's ground post. Connect ground to the ground post of the Coupler and tighten the spade lug in the ground post. If no signals are heard the connections at the receiver are reversed, so interchange them. This use opens the whole field of noise-reducing antennas to sets otherwise denied this advantage.

(3)—Use of standard antenna, of the inverted L, or T type, with a receiver with only antenna and ground posts. Connect single antenna leading to either press post marked "Ant." Connect flexible leads from Coupler tip jacks to the respective antenna and ground posts of the receiver. Connect ground to the ground post of the Coupler, tighten the spade lug in the ground post, and run a wire from ground post to otherwise unused "Ant." press post of the Coupler. Reverse connections at receiver if signals are absent.

(4)—Use of a standard antenna with a receiver equipped for doublet connection (having two antenna posts). Connect the single antenna leadin wire to one of the "Ant." press posts of the Coupler. Connect flexible leads from the Coupler tip jacks to the two antenna posts of the receiver. Connect ground to the ground post of the coupler and tighten the spade lug under the ground post of the Coupler.

The Bernard All-Purpose Antenna Coupler is an effective and ready means of improving reception by the use of a small, inexpensive device, one based on sound engineering principles, and built for many years of service. The Coupler may be placed at any convenient point indoors, but the closer it is to the receiver, the better the noise-reducing properties.

Bernard All-Purpose Antenna Coupler, list price, \$2.50  
Net Price .....\$1.50

**GUARANTY RADIO GOODS CO.**  
145 West 45th Street, New York, N. Y.

## PRINCIPLES of P. A. PUBLIC ADDRESS SYSTEMS

• A practical handbook, full of useful information, fully illustrated, written by M. N. Beitman, an engineer and noted authority on amplifiers.

• Considers in detail two-button and condenser microphones, radio and phono input, acoustic feed back, mixing and volume controls, use of vacuum tubes, interstage coupling, power amplifiers, output coupling, loud speaker placement, the decibel, P. A. measurements, power level, and other points of importance including actual circuit diagrams of P. A. systems.

• Everything about public address practice. Price: 50 cents, postpaid.

**SUPREME PUBLICATIONS** 3727 West 13th St. Chicago, Illinois

# Franklin Transformers

"Most Sock Per Dollar"

## GENERAL REPLACEMENT

Years of experience dating back to the early days of separate A & B power supplies are incorporated in present Franklin units designed for every purpose.



## SOUND

Public address transformers to match hundreds of impedance combinations. Catalogue contains large number of circuit diagrams including Class A Prime.

## AMATEUR

A complete line for filament, grid or plate supply, chokes, Class B modulation, etc. Illustration shows one type. Share your transformer problems with Boyd Phelps W2BP-W9BP in charge of this department.

WRITE FOR CATALOGUES, GIVING YOUR JOBBER'S NAME

No. 51 General Replacement. No. 70 Sound. No. 52-C Amateur

**FRANKLIN TRANSFORMER MFG. CO.**

607 22nd Avenue, N. E., Minneapolis, Minn.

# Quick-Action Classified Advertisements

5 cents a word. 50 cents minimum.

**WORK AT HOME:** Men, women make good money. Particulars for stamp. Chas. Link, 3286 East 116th St., Cleveland, Ohio.

**UP TO \$300 PAID FOR DIMES** dated before 1895; Liberty Head Nickels \$200; Colonial Coins \$300. Send 15c complete Catalog. Nationalcoin, (LL) Springfield, Massachusetts.

**INVENTIONS WANTED.** Patented or unpatented, any size, any material, for any legitimate purpose. Now is the time to act. Send us your ideas. A square deal assured. Bosley Mfg. Co., 79 High Street, Torrington, Conn.

**COMPLETE TRAINING FOR AMATEUR LICENSE,** \$1.50 weekly. N. Y. Wireless School, 4 West 105th Street, New York City; phone: CLarkson 2-7456.

**"WILCOX AUTO ELECTRICIAN'S WIRING MANUAL"**—Complete wiring diagrams for all U. S. cars made in 1928-1929-1930-1931-1932. Complete data on ignition systems, generators, starting motors, batteries and lighting. Printed on tough, wear-resisting paper that can be washed with gasoline without injury to print or paper. Loose-leaf style in sturdy covers. Size 11 x 12". 300 wiring diagrams. Price \$10.00. **RADIO WORLD,** 145 W. 45th St., New York City.

**"RADIO TROUBLE SHOOTING,"** E. R. Haan. 361 pages. 300 illustrations. \$3. **RADIO WORLD,** 145 W. 45th., N. Y. City.

**"SWOOP'S LESSONS IN PRACTICAL ELECTRICITY,"** 17th Edition, Revised by Erich Hausmann, E.E., Sc.D. Requires no previous technical knowledge; fully explains every question about the entire subject of electricity. New chapters on vacuum tubes, telegraphy, telephony and radio signalling. 799 pages, 542 illustrations, 5 1/2 x 8, Cloth, \$2.50. **Radio World,** 145 W. 45th St., New York, N. Y.

**"RADIO TROUBLE SHOOTING,"** Second Edition, by E. R. Haan. Contains the latest on A.C. receivers, dynamic speakers and television. A practical book for practical men. Contains a special chart showing all possible radio troubles and the way to detect them. Size 6 x 9 inches. 361 pages, 300 illustrations. Flexible binding. Price \$3.00. **RADIO WORLD,** 145 W. 45th St., New York City.

**"RADIO AND TELEVISION,"** by James R. Cameron. Over 540 pages, 275 illustrations; cloth bound. The subject of radio and television covered in such a manner that it is easily understood even by a beginner. Price \$4.00. **RADIO WORLD,** 145

**NEW RADIO AMATEURS HANDBOOK,** 180,000 words, 207 illustrations, 218 pages (10th edition, issued 1933). Issued by the American Radio Relay League. Price, \$1.00 per copy. **Radio World,** 145 West 45th Street, New York, N. Y.

# WIDE SELECTION of PREMIUMS with SUBSCRIPTIONS

- OFFER A—Free with \$1.00 subscription, 8 weeks.
- OFFER B—Free with \$1.50 subscription, 13 weeks.
- OFFER C—Free with \$3.00 subscription, 26 weeks.
- OFFER D—Free with \$6.00 subscription, 52 weeks.

## COILS

Aerial eliminator. Dispenses with necessity of an aerial erection. Order P-1400. Offer A.  
Police thriller short-wave adapter plugs into set for police calls. For 27 detectors only. Order P-1402. Offer B.  
Silver-Marshall output transformer, 1 to 1 ratio for single-sided circuit, magnetic speaker. Order P-1403. Offer B.  
Silver-Marshall output transformer, push-pull Pentode (7,000 ohm load) to 8-ohm secondary. Order P-1403. Offer B.  
Kit of three doubly-tuned, aluminum-shielded, 175 kc. i-f transformers. Order P-1408. Offer D.  
Set of four 4-prong plug-in coils, 200-15 meters, for use with 0.00014 mfd. Three windings. Order P-1426. Offer C.  
Power transformer for 5-tube set (2.5v., 5v., h-v.), 60 ma. Order P-1428. Offer C.  
Power transformer for 8-tube set (2.5v., 5v., h-v.), 90 ma. Order P-1429. Offer D.

## CONDENSERS

Three-gang 0.00014 mfd. tuning condensers for short waves. Order P-1031. Offer C.  
Selection of 15 fixed mica moulded condensers, .0001 mfd. to .001 mfd. State capacities and quantities. Order P-1415. Offer B.  
Hammarlund Star Midget condenser. 0.00014 mfd. Order P-1417. Offer B.  
De-Jur Amsco dual 0.00014 mfd. Order P-1418. Offer C.  
Three 100 mmfd. compression type trimmer condensers. Order P-1419. Offer A.  
Eight tubular condensers, 600 volts. Capacities, .002, .006, .01, .02. State quantity and capacities, your selection. Order P-1420. Offer A.  
Three tubular condensers, 600 volts, .01, 0.25 mfd. Your selection. State quantities and capacities. Order P-1421. Offer B.  
8 mfd. electrolytic, 500v. d.c. Order P-1422. Offer B.  
16 mfd. electrolytic, 500v. d.c. Order P-1423. Offer C.  
Two 8 mfd. electrolytic in one case. Order P-1424. Offer C.  
Three-gang 0.00035 mfd. 3/8-inch shaft diam. Order P-1425. Offer B.

## RESISTORS

Kit of 12 assorted volume controls (our selection). Order P-1401. Offer A.  
Kit of 25 fixed assorted resistors (our selection). Order P-1404. Offer A.  
Kit of 50 fixed assorted resistors (our selection). Order P-1404. Offer B.  
Volume control potentiometers with a-c switch attached: 5,000 ohms. Order P-1409. Offer B.  
10,000 ohms. Order P-1410. Offer B.  
20,000 ohms. Order P-1411. Offer B.  
50,000 ohms. Order P-1412. Offer B.  
500,000 ohms. Order P-1413. Offer B.  
Selection of 15 pictall fixed resistors, 1/4 watt. State values and quantities desired. Order P-1414. Offer B.

## MISCELLANEOUS

Two 45 tubes. Order P-1405. Offer B.  
Two 28 tubes. Order P-1406. Offer B.  
Assortment of screws and nuts. Order P-1407. Offer A.  
Twelve tube trays and bases. Order P-1416. Offer A.  
Set of 12 wafer type sockets, four, five, six, seven-medium holes. State quantity and holes. Your selection. Order P-1426. Offer B.  
Set of 6 three-piece aluminum shields. Order P-1427. Offer A.

[NOTE: We pay transportation on any and all of above premiums. This offer to pay transportation is revocable at any time, so act now.]

# RADIO WORLD

145 West 45th Street New York, N. Y.

# Design and Use of I-F Coils

## Wire and Winding Performances Compared and Connections Analyzed

By *F. H. Scheer*

Engineer, *F. W. Sickles Co.*

THE general acceptance of the superheterodyne circuit has greatly stimulated development of this type of receiver. In addition, new tubes have, to a great extent, facilitated the design problems.

However, superheterodynes develop most of their gain and selectivity in the intermediate frequency stages. Other problems such as image response, cross-talk and improvement of signal to noise ratio necessitate the addition of a radio frequency amplifier and its attendant selective circuits ahead of the frequency converter tube. This added radio frequency gain and the high audio amplification commonly used at the present time make the use of one intermediate frequency stage attractive to design engineers. One stage means a struggle to obtain sufficient gain and selectivity. Two stages often require means for losing gain.

The tendency to use higher intermediate frequencies in order to lessen image response has brought on more problems. For example, in order to obtain an amplification at 456 kilocycles equivalent to that at 175 kilocycles, the effective figure of merit of the coils,  $Q$ , has to be increased two times. In order to obtain the same selectivity,  $Q$  has to be increased 2.6 times.

Intermediate frequency transformer development may be divided into a study of suitable coils, condensers and couplings.

### Figure of Merit

The merit of coils is determined by the sharpness of resonance, expressed as  $Q$ . Sharpness of resonance is defined as the fractional change in current in an oscillatory circuit for a given change in either capacity, inductance or frequency.

It may also be shown that  $Q$  is equal to the ratio of inductance or capacitive reactance to the resistance.

The  $Q$  of a coil may be determined in several different ways. The capacity variation method is here cited as an example. The following apparatus is required: an oscillator of sufficient power so that small loads may be imposed with negligible change in its output voltage or frequency, a tube voltmeter having a high input impedance and a calibration point at 0.71 times full deflection and a calibrated, low-loss variable air condenser. Current is induced into the coil to be measured by coupling directly to the oscillator. The tube voltmeter is connected across the variable condenser. Coupling is adjusted so that at resonance the meter reads full scale. The condenser is then detuned and two capacities,  $C_1$  and  $C_2$ , at which the voltmeter reading is 0.71 of full scale, are recorded.

$$Q = \frac{C_2}{C_2 - C_1}$$

$C_1$  is the total capacity (including the distributed of the winding) across the coil at resonance.

### Wire Sizes

It will be noted in this procedure that voltages are read instead of currents, which are required in the definition of

sharpness of resonance. An error is introduced which ordinarily may be neglected. The formula is less than 1/10 of one percent wrong down to  $Q$ 's of 31.6.

One consideration of coil design is the kind and size of wire. Solid wire is used mainly in the lower frequency intermediate transformers because high  $Q$ 's are not needed to obtain good gain and selectivity. Litzendraht is used to advantage up to 1,000 kilocycles. Two sizes are most popular, one consisting of seven strands of No. 41 enameled wire and the other consisting of three strands of No. 40 enameled wire, both silk covered.

Another important feature is the form factor. In general, universal windings are better if they are narrow and wound on large diameter forms. Also, the more cross-overs the wire makes in one revolution the better. Of course, these general statements must be modified to suit mechanical requirements. A recent development uses several universal wound pies in series. This type of winding is distinctly advantageous in the region of 450 kilocycles.

Bank windings are very good in the broadcast band. Size prevents their use at lower frequencies.

Trimming condensers require careful design. Good condensers add little to the total resistance of the tuned circuit, but poor ones may detract all the benefit from high  $Q$  coil construction. The mica used must exhibit no flaws and must not be split. Good design provides long leakage paths between the points of high R. F. potential.

Ease of adjustment is an important mechanical consideration. The most popular types of trimmers are adjustable from the top of the assembly. Common practice is to insulate the adjusting screws.

Recently air dielectric trimmers have appeared on the market.

### Shields Compared

Shielding of i-f assemblies is a necessary evil. A drawn can of pure aluminum effectively prevents electrostatic coupling between transformers and reduces the magnetic field sufficiently to prevent interaction except at very low frequencies. A copper can would undoubtedly be better but copper soon becomes corroded if not plated. In general, larger shields intro-

duce lower losses in the coils, tests show. Electrical linkage between transformer coils is a combination of magnetic and capacity couplings. If both primary and secondary coils are wound in the same direction, and the starts or finishes are plate and grid connections, it will be found that the magnetic coupling opposes the electrostatic coupling. Two points of sufficient coupling are sometimes found: one with magnetic coupling predominating and the other with electrostatic coupling in excess. The last condition can be obtained only when the fixed capacity between the circuits is large.

### Gain and Selectivity

If the connections to one of the coils are reversed, the couplings become additive. At the point of optimum gain, under these conditions, the couplings are less divergent and it, therefore, may be a more desirable condition for manufacturing as the spacing of the coils is less critical.

Adjusting an i-f transformer for best gain does not give best selectivity. Conversely, best selectivity would mean low gain. Usually, a compromise is struck. Over-coupling with high  $Q$  coils gives decided double humps. These double humped transformers cannot be properly tuned after the coil spacing is fixed except by loading down either of the circuits with a suitable resistor.

In high fidelity receivers it is required that an i-f amplifier should have a wide, flat-nosed selectivity curve. To obtain these flat-nosed selectivity curves, it appears that i-f transformers should have low  $Q$  coils. But, a large number of tuned circuits would be necessary to give sufficient rejection characteristics for signals on adjacent channels. An excellent overall i-f curve for broadcast reception would be plus or minus 8 kc wide at the nose and would be down 40 decibels at plus or minus 10 kc. In the newly introduced high fidelity receivers, some if assemblies make use of three tuned circuits instead of the usual two to achieve this result. [A description of such a unit was published in the December 1st 1934 issue of *RADIO WORLD*.] With these assemblies, i-f curves with steeper sides and broader noses are possible. Of course, this is a very desirable improvement, and is a convenient toll for use in high fidelity circuits.

## Wavelength-Frequency Table

Since a great many people have become short wave conscious, a growing need has been felt for the ability to interpolate frequencies of short wave stations into their appropriate wave lengths and vice versa. This need has been incurred by the fact that notifications of the programs of these foreign stations are usually given in terms of wave length while the short wave receiver may be calibrated in terms of frequency. Therefore, in order to be able to receive the desired station, it is essential that its position on the receiver dial be capable of discovery.

This process might be accomplished by means of fairly complicated calculations but for the sake of simplicity, this method has its shortcomings. It is because of the ease with which a chart may be read that a conversion chart of frequency and wave length is herewith presented on page 21.



# Station Sparks

By Alice Remsen

## GOOD WISHES TO ALL!

**T**IME TO SAY MERRY CHRISTMAS, folks! Hope you spend a fine one, with lots of good cheer, cards and gifts—and don't forget those more unfortunate than yourself. There are many these days in need of a little help. Do what you can and your Christmas is bound to be cheerful. . . .

## SETH PATCHED UP

It's good to hear Seth Parker back on the air again. The reason Phillips Lord was off for a while was because his short-wave transmitter was damaged during a storm and the transmitter resistance coil burned out. This happened in the South Pacific, thousands of miles away from the nearest radio supply base. So remote had been the possibility of such an accident, that Lord and his technician, Carey P. Sweeney, had failed to carry spare coils. Temporary repairs were effected, enabling the Seth Parker operator to communicate with NBC engineers by wireless code through RCA facilities. Then started tedious code conversations between George Milne, NBC Eastern Division engineer, in Radio City, and Sweeney, almost ten thousand miles away. The NBC engineers ascertained what materials were available on the Seth Parker, then they set to work designing substitute coils from the meager supplies aboard the schooner. Daily for over a week Milne gave minute directions to the Seth Parker operator. Through the use of wireless code, the engineers in Radio City relayed a verbal blue print to Sweeney. Then came the tests—and the substitute resistance coils worked, and so Lord is able to continue his Tuesday programs from out-of-the-way ports visited by the Seth Parker, over WJZ at 9:15 p.m. . . .

## THE PICKENS GIRLS—AN' WHY!

The Pickens Sisters are making frequent appearances on the Maxwell House Show Boat; the reason—because they proved so popular on their first appearance. The girls are clever and just as sweet as they look. . . . There's a new sports program over the NBC-WEAF network these Saturdays, at 6:45 p.m. The well-known sports writer and commentator, Thornton Fisher, is in charge, and is presenting many popular figures from the world of sport on each program. . . . How do you like the Breen and De Rose-Bob Emery series? They are on four mornings a week, Sunday, Monday, Wednesday and Friday, at 10:30 a.m. over NBC-WEAF, under the sponsorship of Humphrey's Homeopathic Medicine Company. . . . Dorothy Page, beautiful NBC contralto, who sings from the Chicago studios, has won the National Editor's Poll for being the most beautiful girl in radio—and I honestly believe she is just that! . . . Yvonne Gall has ended her limited engagement with Paul Whiteman, and has returned to Paris, where she will appear in opera. . . . Ruth Cornwall, the talented author of the Death Valley Days sketches, is due back in New York very shortly with plenty of new material for the sketches, gathered during a tour of the frontier part of San Bernardino County and Nevada. She had W. W. Cahill, superintendent of the Tonopah and Tidewater Railroad, and one of the best known authorities on the desert country, as her guide. Another member of the party was C. B. Zabriskie, retired general manager of the Pacific Coast Borax Company, which sponsors Death Valley Days.

## ROXY IS HAPPY

Roxy and His Gang started on their contract renewal December 15th. Since its inception on September 15th, the program, which is both Roxy's first sponsored series and his first series on the Columbia network, has become one of the most popular air offerings of the week-end. Roxy has endeavored to preserve something of the informality and warmth that characterized the pioneer days of broadcasting. The results have been more than gratifying to the veteran impresario. . . . The "Two Doctors" of the "Laugh Clinic"—otherwise known to radio audiences of the middle west as Pratt and Sherman—have introduced a fresh brand of nonsense in a new WABC-CBS daytime show, each Tuesday at 10:30 a.m. Co-featured with them are Al Roth's Orchestra and Eddie Dunstetter, the organist who gained nationwide fame on the CBS "Fast Freight" series. . . .

## THE OTHER HALF

An opportunity to hear how "the other half of the world" lives and celebrates Christmas Day will be given to American radio listeners on December 25th when the four corners of the earth will literally be linked together over the WABC-Columbia network in one of the most ambitious international broadcasts ever attempted. It will begin with a bell sequence, which will bring to American loudspeakers the chiming of Christian bells in such far-flung places as Bethlehem, Bombay, India, Wellington, New Zealand, Ottawa, Canada, Ireland and London. This splendid feat of radio engineering will be followed by a narrative depicting life and work at Christmastide in various parts of the British Empire. Columbia microphones will carry messages to the American public from the people of the British provinces as far north as Canada and as far south as Southern Rhodesia, South Africa. It is expected that the program will be climaxed by a message from a ruling member of the British Royal family. The whole thing should be well worth a twist of the dial. . . .

## JUST AROUND THE CORNER

Donald Novis is doing quite a lot of work over the WABC-Columbia network these days. . . . The Columbia Broadcasting System deserves a whole lot of credit, they kept their word and have inaugurated no less than fifteen new daytime shows since Fall. Some of them are well worth while—and why shouldn't they be? The daytime listener is just as important to my mind as the evening tuner-inner. Such radio favorites as Fray and Braggiotti, Vera Van, Johnny Green, Freddie Rich, Kate Smith, Cobina Wright and many others now have daytime schedules. Let's hope they keep it up. . . . A new musical variety program, "Paradise Island," interwoven with an exciting plot, is being heard over the WMCA-ABS network on Tuesdays at 8:30 p.m. It has a rather fanciful plot, but is good entertainment. . . .

## STUDIO NOTES

Tommy Harris, NBC's little king of song, is a descendant of Mendelssohn, the composer. . . . Don Bestor is married to Frankie Klessem, who was formerly a dancer. . . . Lewis James, the second tenor of the Revelers, is also their business manager. . . . Eddie Guest, the poet, is clerking in a Detroit drug store. . . . And here's news: Graham McNamee was once

## A THOUGHT FOR THE WEEK

**M**ARY PICKFORD MAY BE CONSIDERED ODD by a good many folk, especially when she declares that she just doesn't want to and will not play "un-nice" ladies. This declaration from a woman who has been famous for two decades was made in discussing the roles she is playing in radio, and indicates that Miss Pickford has not changed very much from the time she won her right to be known as "The nation's sweetheart."

There's one thing to be said for Miss Pickford in this connection. She has never been afraid to be considered old-fashioned, whether in pictures, on the stage or elsewhere—and, in view of her reputed wealth, running into the millions, it cannot be said that the consistency with which she has worked out her resolve has been unprofitable.

a chorus boy in "The Purple Road" at the Casino Theatre, New York City. . . . Jack Benny always wears his hat during rehearsals. . . . Mark Warnow still has the first dollar he earned. . . . Myrt and Marge are rapidly becoming trap-shooting experts. . . . Kate Smith likes a studio with a temperature of 75 degrees. . . . Emery Deutsch thinks it's too hot at 65.

## 217-A-MINUTE

**CANDID CAMERAGRAPH: FLOYD GIBBONS:** the 217 word-a-minute man . . . breezes into the studio with a quick-stepping secretary . . . takes off his light gray felt hat and camel-hair coat . . . grabs a fistful of red pencils . . . pokes a cigaret into a corner of his mouth for a few quick puffs . . . puts on his fedora again . . . snaps the brim down over his eyes . . . carries a glass of water to the table . . . sits abruptly at the table lighted by a desk lamp with green shade . . . huddles over the microphone . . . puts on one lens-tortoise shell spectacles . . . unbuttons his vest . . . loosens his collar . . . now the words tumble forth . . . the left hand removes page after page of his script and drops them on a chair . . . his right hand moves above the microphone, gesturing with fingers loosely outstretched . . . sometimes he points an eloquent index finger . . . takes quick short breaths . . . his head shakes with the speed of his delivery . . . during announcements his mouth moves as he reads to himself . . . now the words again tumble forth and there you are!

## SUBSCRIBE NOW!

YOU CAN GET TWO FULL YEARS—  
104 ISSUES—ONE EACH WEEK—FOR \$10.00

RADIO WORLD, 145 West 45th St., New York City. Enclosed please find my remittance for subscription for RADIO WORLD, one copy each week for specified period.

- \$10.00 for two years, 104 issues.  
 \$6 for one year, 52 issues.  
 \$3 for six months, 26 issues.  
 \$1.50 for three months, 13 issues.  
 \$1.00 extra per year for foreign postage.  
 This is a renewal of an existing mail subscription (Check off if true)

Your name .....

Address .....

City .....

# DIAMOND OF THE AIR DUAL-WAVE SUPERS

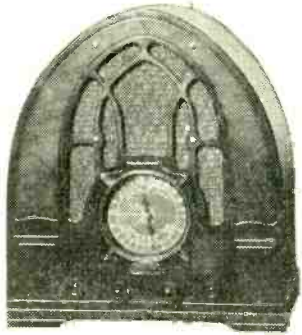

The 1010 chassis in a Gothic model table cabinet; wired, with dynamic speaker; five RCA tubes. Cat. 1010-G. \$17.51

THE principal foreign-short-wave stations are on waves between 18 and 55 meters. Therefore we have a five-tube a-c superheterodyne for covering the broadcast band (550-1,500 kc) and the principal short-wave bands, a dual-wave receiver of excellent performance. Band selection by front-panel switching.

This is our Model 1010, obtainable as a wired chassis, with speaker and five RCA tubes; or in either of two table model cabinets, or in a console. The same receiver is used in all four instances.

The tubes used are one 6A7, one 6D6, one 75, one 42 and one 80. The illuminated airplane dial has a double pointer and is calibrated in kilocycles. Automatic volume control is included. There is provision for phonograph pickup connection or ear-phones. A tone control and manual volume control are provided. A dynamic speaker is used. The primary power rating is 60 watts.

Principal foreign stations are brought in with simple ease and remarkable clarity. The Gothic cabinet illustrated above, with wired set, speaker, complete with tubes, is Cat. 1010-G. Cabinet is 10 inches wide, 14 1/2 inches high, 7 inches front to back. Shipping weight, 17 1/2 lbs. Net price (F.O.B. Sandusky, O.)..... **\$17.51**

The same receiver in the de luxe model table cabinet, illustrated below, Cat. 1010-DL. Same shipping weight..... **\$18.65**

The same receiver in modernistic console, shipping weight, 45 lbs. Cat. 1010-CON..... **\$27.25**

Wired chassis, tubes, dynamic speaker, Cat 1010-CH..... **\$15.38**

Above models are for 50-60 cycles, 110 volts. Models for 25 cycles, \$1.50 extra, net. Add the number 25 to the catalogue number. Or, for 50-60 cycles, 220 volts, add 60 cents net, and add the number 220 to the catalogue number.

Battery Model. We can supply the 1010 model in the same cabinets, at the same price as for a.c., but for battery operation. The prices do not include batteries. Add the letter B after the catalogue numbers.

World-wide reception is enjoyed on the 1935 Series Diamond of the Air Receivers. The series, besides the 5-tube models listed above, also includes an 8-tube all-wave model, 150 kc to 22 mcg, using the 1008 Chassis, obtainable in modernistic table model cabinet or in console, and a six-tube, high-gain automobile set in a single unit, with remote tuning-volume control. Send for circular on 8-tube models and on auto set.

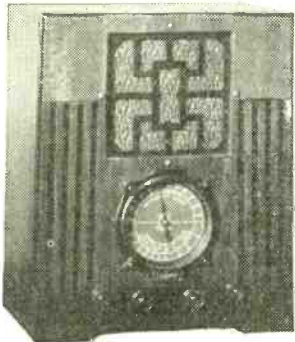

The 1010 chassis in a modernistic, de luxe table model cabinet, complete with dynamic speaker and five RCA tubes. Cat. 1010-DL..... **\$18.65**

Remit with order to benefit by the low prices quoted. State what carrier you prefer or shipment will go by express. You pay transportation. C.O.D. orders accepted on basis of 25% remittance with order, but net prices are 2% higher than those quoted.

**Guaranty Radio Goods Co.**  
145 W. 45th St. New York City

## DUAL-BAND TUNING UNIT

FOR broadcast reception, plus coverage to higher than 4,000 kc, thus yielding a total span of 540 to higher than 4,000 kc. We have an exceptionally precise combination, consisting of three r-f coils, one of which is used as antenna coupler, and one oscillator coil, also the necessary four-gang condenser and the correct padding condenser (Hammarlund adjustable type). The tuning coils for the r-f level have secondaries tapped so that the condenser stator may be switched from full inductance to just enough inductance to pick up the broadcast band where the full inductance left off. The oscillator coil is appropriately tapped, also, for this purpose. A four-pole, double-throw switch would be required (not furnished). Coils aluminum shielded, 2-1/16" outside shield diameter by 2.5 inches high.

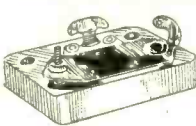

The four-gang condenser is very compact (5 x 2.25 x 2.75 inches). All material is specially made for this premium offer and is of highest calibre. Order Cat. PR-CTU-465 for use with 465 kc intermediate, and enclose \$9 for 18-month subscription (78 issues, one each week), and four-gang condenser, four coils, and 350-450 mmfd. padding condenser, but no switch, will be sent. Small transportation charges collect.

Same as above, same terms, except oscillator is for 175 kc and padder is 850-1,350 mmfd. Order PR-CTU-175.

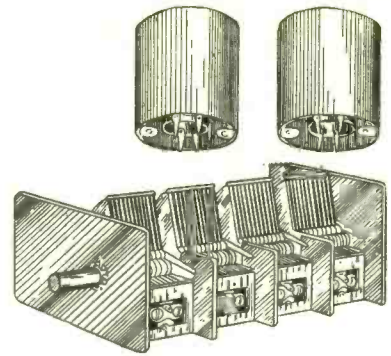

## TUNING UNIT FOR TEST OSCILLATOR

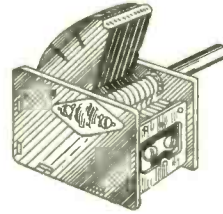
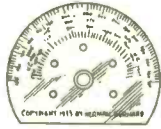

HERE is your very first opportunity to get the parts for constructing a universal, modulated test oscillator to cover fundamentals from 135 to 380 kc, and read higher intermediate frequencies and the entire broadcast band, by harmonics, all imprinted right on the dial. That is, the oscillator will be direct frequency-reading. The parts consist of one metal-etched scale, one metal escutcheon, one 0.000406 tuning condenser with trimmer built in, one oscillation transformer (secondary inductance accurate to 0.1 per cent.), and one knob for condenser. Circuit diagram

supplied for universal model modulated test oscillator (90-120 volts a.c., d.c. or batteries, same oscillator works on all three). Instruction sheet for lining up at broadcast and intermediate frequencies included. Line up the oscillator with one adjustment on broadcast band, beating with some station on 1,200 to 1,400 kc. Whole dial then will track. Order PRE-TUTO and send \$6.00 for one-year subscription for (52 issues). Sent postage prepaid.

### MICA-DIELECTRIC Intermediate Transformers

For 465 kc or 175 kc i.f. we offer doubly-tuned transformers, with mica-dielectric condensers built in, all enclosed in 4-inch high aluminum shield, 2-1/16-inch diameter. Quantity is at left. Sent postpaid.

#### Single Transformer

- (1) PRE-MD-465... \$2.00 subscription, 16 issues
- (1) PRE-MD-175... \$4.00 subscription, 34 issues
- (2) PRE-MDD-465... \$8.00 subscription, 52 issues
- (2) PRE-MDD-175... \$8.00 subscription, 52 issues

The following highest-grade, licensed, brand-new, 10-day-replacement-guarantee tubes are offered as premiums.

One Tube for \$1.00 Subscription, 8 Issues.  
01A, 01AA, 1V, 12Z3, 112A, 24A, 26, 27, 30, 31, 35, 36, 37, 38, 39, 45, 47, 51, 56, 71A, 80, 82.

Any two of above tubes for \$2.00 Subscription (16 issues), any three for \$3.00 Subscription (24 issues), any six for one-year Subscription (52 issues).

### Complete Selection of Tubes



### AIR-DIELECTRIC Intermediate Transformers

For unequalled maintenance of the frequency to which the intermediate channel is adjusted, air-dielectric tuning condensers must be provided. These are supplied on Isolantite forms, and are made by one of America's Premier Precision radio parts manufacturers. Quantity at left.

- (1) PRE-AD-465... \$6.00 subscription, 52 issues
- (1) PRE-AD-175... \$12.00 subscription, 104 issues
- (2) PRE-ADD-465... \$18.00 subscription, 156 issues
- (2) PRE-ADD-175... \$18.00 subscription, 156 issues

One Tube for \$1.50 Subscription, 13 Issues  
1A6, 5Z3, 2A5, 2A6, 2A7, 2B7, 6A4, 6A7, 6B7, 6E7, 25Z5, 22, 32, 33, 34, 41, 42, 44, 46, 49, 53, 55, 57, 58, 59, 67, 75, 77, 78, 83, 83V, 84, (6Z4), 85, 89, 483, 485. Any two of the \$1.50 group for \$3.00 Subscription (26 issues), any four for \$6.00 Subscription (52 issues).

TUBES SENT POSTAGE COLLECT.

## VITAL BOOK

The biggest help any one can get who desires to wind radio-frequency coils for any frequency from just below the audio range to the fringe of ultra frequencies is to have a book that tells just what inductance is required for the condenser one possesses, and just how many turns of any kind of wire on any sensible diameter are needed to produce that inductance. "The Inductance Authority," by Edward M. Shiepe, gives you just that information, to an accuracy of 0.1 per cent. Send \$4.00 for an eight-months subscription (39 issues) and order PRE-1A sent postpaid.

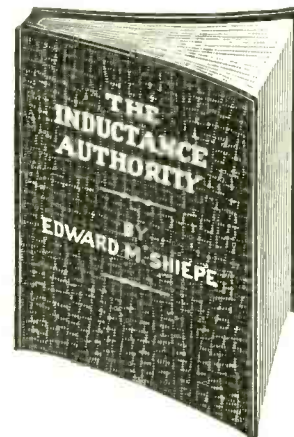

**POWER TRANSFORMER**  
Primary—105-130 volts.  
Secondary A—2.5 volts, center-tapped.  
Secondary B—110 volts, no center tap.  
Splendid for powering a-c test oscillator or any other rectifier for not more than three small tubes.

Order PRE-SPTR and send \$1.50 for three-month subscription (13 weeks) postpaid.

RADIO WORLD, 145 WEST 45th STREET, NEW YORK, N. Y.

## SOME EXCELLENT RADIO BOOKS

- "This Thing Called Broadcasting" by Alfred N. Goldsmith and Austin C. Lescarboursa. \$3.50
- "Audio Power Amplifiers," Anderson, Bernard 1.50
- "Radio Frequency Measurements," by E. B. Moullin..... 12.50
- "Short Waves," by Charles R. Leutz and Robert B. Gable..... 3.00
- "Perpetual Trouble Shooter's Manual," No. 1, by Rider..... 7.50
- "Perpetual Trouble Shooter's Manual," No. 2, by Rider..... \$6.50
- "115 Latest Commercial Set Diagrams," by Rider..... 1.00
- "Drake's Radio Cyclopeda," by Manly.... 6.00
- "Elements of Radio Communication," by Morecroft..... 6.00

RADIO WORLD, 145 West 45th Street, New York, N. Y.

## Small Power Transformer

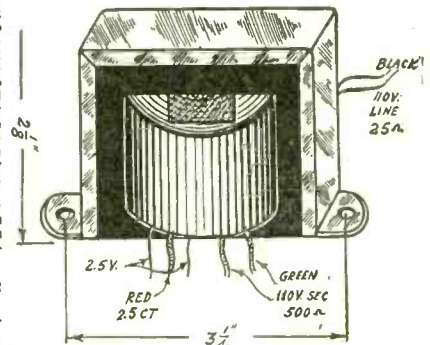

**ORDER NOW**  
**RIDER'S PERPETUAL**  
**TROUBLE SHOOTERS**  
**MANUAL—NO. 5**

1200 pages.  
 112 Manufacturers represented.  
 Socket Layouts . . Schematics . . Volt-  
 age Data . . Alignment Data . . Circuit  
 Notes . . Chassis Wirings . . Parts Lists  
 . . I. F. Peaks.

Special attention paid to Trimmer  
 Locations. 543 different Superhet.  
 chassis. Right up to October 1934!  
**\$7.50**

**Book Dept., RADIO WORLD**  
 145 West 45th Street, New York, N. Y.

**SPECIAL**

Set of 16 "1934 Design"

**BLUE**  
**PRINTS**

- Short Wave Receivers
- Short Wave Converter

*For Limited* **50c**  
*Time Only*

Add 5c for postage. 10c for foreign  
**RELIABLE RADIO CO.**  
 145 W. 45th St., New York City

**Short-Wave Condenser**

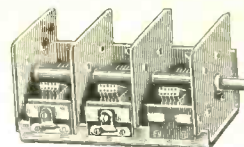

Three-gang 0.00014 mfd. tuning condenser, with high shields between sections. Trimmers built in on two of the sections. Section with trimmer off is to be used for antenna-stage tuning. As a series variable antenna condenser, of 50 mmfd. or somewhat less, is recommended, and changes the tuning of this stage, no fixed trimmer is necessary here. The condenser has brass plates, such as the most expensive condensers have, and has 3/8" shaft. Shipping weight 4 lbs. Send \$2.50 for 20-week subscription for RADIO WORLD (20 issues, one each week), and ask for P-1031. Enclose postage extra or shipment will be made express collect. We do not pay transportation on these condensers.

Radio World, 145 W. 45th St., New York, N. Y.

*World-Famous*

**SHORT-WAVE PRODUCTS**

**"COSMAN TWO"**



Battery operated S. W. receiver. Novel rack permits placing of five coils in proper band order—no groping for coils. Efficient design permits tuning from 15 to 200 meters. The regular broadcast band can be tuned with a broadcast coil (200 to 550 meters) at additional cost of 39c. Uses a 232 and 233 tube.  
 Kit of parts.....\$5.95  
 Wired and tested ..... 1.50 extra  
 Set of RCA licensed tubes..... 1.40

**"DUO WONDER"**



2-in-1 short wave receiver. Features the new type "19" tube. Supplied with coils to cover the entire wave band, without any gaps whatsoever, from 15 to 200 meters. A fifth coil, covering the broadcast band (200-550 meters) supplied for 39c additional.  
 Kit of parts .....\$4.95  
 Wired and tested..... 1.00 extra  
 RCA licensed '19 tube..... .60

**DICTATOR of the AIR**  
*Battery Short Wave*  
**RECEIVER**

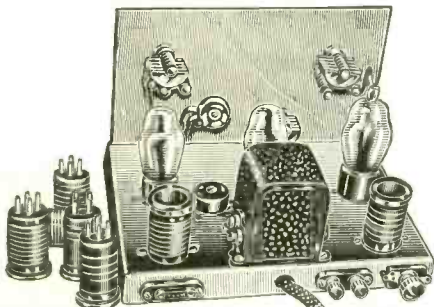

Made famous by its consistent reception. Will tune stations from every corner of the globe—from 15 to 200 meters with Powertone plug-in coils. Two sets of coils are used with the Dictator of the Air for clearer and more decisive reception. Uses 1-234 and 2-230 tubes.  
 Kit of parts .....\$9.95  
 Wired and tested..... 2.00 extra  
 RCA licensed tubes..... 3.10

*Short Wave*  
**POWER**  
**PACK**

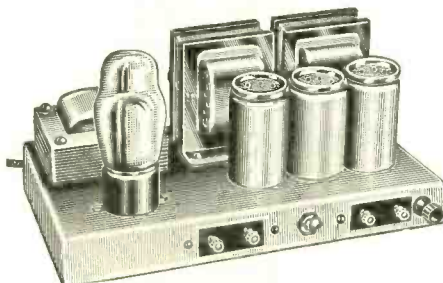

Supplies clear, hum-free power, regardless of circuit sensitivity. Especially designed for use with Dictator of the Air battery receivers. Delivers 180 volts with taps at 135, 90 and 45. Supplies 2 1/2 volts at 10 amps. Uses 280 rectifier tube.  
 Wired and tested with tube.....\$5.95

John F. Rider's Vol. IV  
**Perpetual Trouble Shooter**

**S**ERVICING during 1934 will be more complicated than at any time during the past 14 years of radio activity. Volume IV is your means of combating the numerous highly scientific problems of design introduced by the receivers sold during 1933.

"I do not hesitate to say that Volume IV is the most important of all the manuals I have issued. Volumes I, II and III found their place in the servicing world as important aids to the service man . . ."

"Volume IV is destined to be more than just an important aid. . . . It will be a vital necessity. . . . I am firm in the belief that because the contents of Volume IV cover the most scientific and complicated radio receivers ever produced in the history of the radio industry—its ownership will mean the difference between success and failure when servicing the 1933 crop of radio receivers. John F. Rider."

Volume IV has in it 1040 pages in the loose leaf binder; about 20 pages in a separate supplement and the index, covering all of the manuals, totals about 40 pages, making a grand total of approximately 1100 pages.

The binder used in Volume IV is identical to that employed for Volume III. It is loose leaf employing the finest of materials. Aligner bar "instant removal" mechanism is employed.

Volume IV, Price \$7.50, postpaid

- Also:
- Volume I, Rider's Perpetual Trouble Shooters Manual ..... \$7.50
  - Volume II—Does not duplicate Vol. I ..... 6.50
  - Volume III ..... 7.50
  - Rider's Combination "3 in 1" Manual, now ready (Vols. I, II and III) ..... 21.50
  - Rider's Combination "3 in 1" Manual, with carrying handles ..... 25.00

Address: BOOK DEPT.

**RADIO WORLD**  
 145 W. 45th St., New York, N. Y.

**FOREIGN RECEPTION**  
**WITH AN AUTO SET**

Designed by J. E. Anderson

using two 39's, two 36's, two 37's, one 85 and one 89. We have had a number of reports of foreign reception with this set. It is the most sensitive receiver we have tried. AVC prevents fading.

Wired set with tubes, speaker and remote control less **\$34.70**  
 batteries .....

**RELIABLE RADIO CO.**  
 145 W. 45th St., New York, N. Y.

"RADIO TROUBLE SHOOTING," E. R. Haan. 328 pages. 300 illustrations. \$3. RADIO WORLD, 145 W. 45th St., N. Y. City.

**RELIABLE RADIO CO., 145 W. 45th St., New York**