

MARCH 24th

1934

15¢ Per Copy

RADIO

REG. U.S. PAT. OFF.

WORLD

The First and Only National Radio Weekly
626th Consecutive Issue—Thirteenth Year

10-TUBE DUAL-RANGE SUPER

—
Why Grid Leak Detector
and Diode are the Same

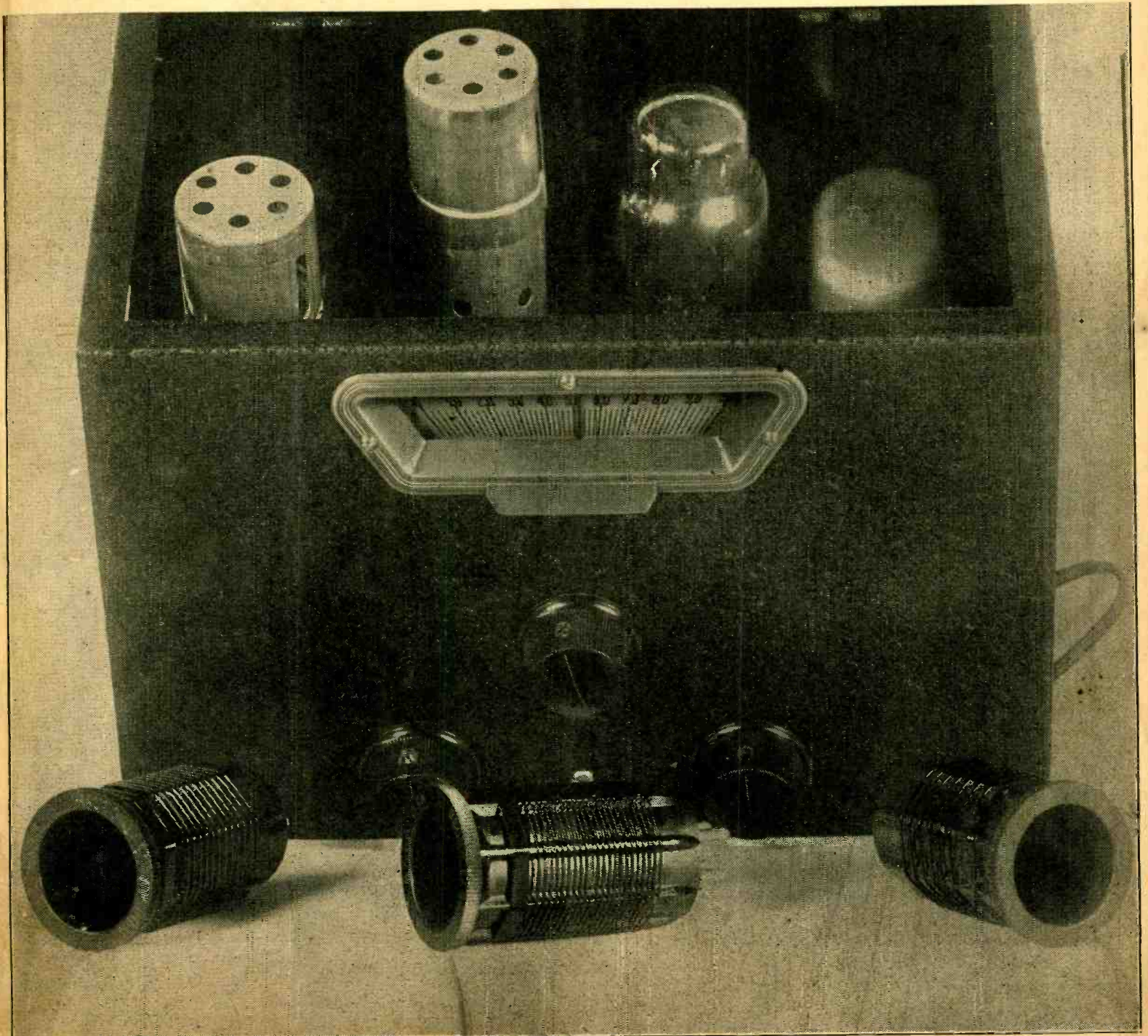

A three-tube short-wave earphone receiver, with B supply built in.
A total of only four plug-in coils is used. See page 8.



POWER TONE



3-Tube A.C. Short Wave Receiver

As described in this issued by Emanuel Mittleman

A special filtering system employed creates quiet hum-free reception. Utilizes the high grade plug-in coils, reducing coil losses to an absolute minimum.

The entire rust-proof chassis is placed into a beautiful, modernistic, crystal-finished cabinet. Tunes from 15 to 550 meters.

using **Hammarlund** PRODUCTS

Kit of parts with Bruno coils, \$10.95; wired and tested, \$12.95; set of Sylvania tubes, \$1.75; matched headphones, 95c.; broadcast coil (200-550 meters), 79c.

The "SCOUT"

ONE-TUBE SHORT WAVE RECEIVER

15 to 550 Meters

Described in Radio World, Feb. 10, 1934

A Receiver that will cover the entire short wave and broadcast band. Amazing the way it intercepts short wave signals, police signals, ship-to-shore signals, airplane conversations, amateurs, etc. An inexpensive short wave receiver.

Kit of parts with Bruno coils, \$3.95; wired and tested, \$1.00; set of batteries, \$1.50; matched headphones, 95c.



HANDY
Serviceman's
Manual, 25c

TRY-MO RADIO COMPANY, INC.

85 CORTLAND ST., N. Y. CITY, N. Y.
Dept. R. W.
178 Greenwich St. 179 Greenwich St.

FREE!

New handy - sized
catalog now ready.
Send for your copy.

STEADY INCOME! Anywhere.

We furnish 50 Complete Mail Order Plans prepaid, only \$1.00. Or 20-Lesson Course in Newspaper Correspondence, \$1.00. List Famous Dollar Courses Free. Satisfaction guaranteed.

ASSOCIATED MANAGEMENT, Recovery Division,
1700 N Sansom Street, Philadelphia, Pa.

"MODERN STORAGE BATTERY PRACTICE," by A. D. Althouse and Carl H. Turnquist, of Cass Technical High School, Detroit. A new and practical handbook prepared for the beginner and experienced battery man alike, and includes methods, materials, equipment, tables and special data, also index for quick references. 277 pages, 258 illustrations, flexible binding. Price \$2.50. RADIO WORLD, 145 W. 45th St., New York City.

How to improve **NEW** The Postal **BOOSTER**

S. W. RECEPTION

The latest short wave sensation. brings your present short or All-wave receiver years ahead of the latest on the market. It increases the sensitivity and selectivity of your receiver over 300%. It eliminates repeat spots, image frequencies and lowers the background noise considerably.

A genuine custom built laboratory instrument designed especially for the serious-minded short wave Fan or Amateur. Self powered, self contained, easy to install, guaranteed. Write for free circular describing the Postal BOOSTER and our special low price.

POSTAL RADIO 135 W. Liberty St. New York, N. Y.

BOTH FOR ONE FULL YEAR
RADIO WORLD
and "RADIO NEWS"

\$7.00

Canadian and Foreign, \$1.50 extra.

You can obtain the two leading radio technical magazines that cater to experimenters, service men and students, the first national radio weekly and the leading monthly for one year each, at a saving of \$1.50. The regular mail subscription rate for Radio World for one year, a new and fascinating copy each week for 52 weeks, is \$6.00. Send in \$1.00 extra, get "Radio News" also for a year—a new issue each month for twelve months. Total 64 issues for \$7.00.

RADIO WORLD, 145 West 45th Street, New York, N. Y.

NEW EDITION (1934) "THE RADIO AMATEUR'S HANDBOOK"

published by the American Radio Relay League, just out (eleventh edition). Almost completely rewritten and re-illustrated. Changes in technique introduced during 1933 fully covered. Several chapters entirely new.

PRICE, \$1.00, POSTPAID
RADIO WORLD, 145 West 45th Street,
New York, N. Y.



NEW

RADIO EXPERIMENTERS! IMPROVE THAT JOB!

KIT enables you to know where to find that certain size of screw, nut, bolt, washer, lug, or what-not. Specially designed box has 12 compartments in which hardware is classified. Box made so that when cover is closed, the contents of one compartment will not slide into another. All compartments are marked as to contents.

Contains Over 500 Pieces
Among the contents are the following sizes of machine screws and nuts, with washers to match, several different lengths of screws from 1/4" to 2" for each size thread and both flathead and roundhead screws included; 2-56, 4-36, 6-32, 8-32 and 10-32. More pieces of the more useful sizes are given, the ratios being determined scientifically. For example, one compartment contains the complete assortment of 4-36 screws and nuts, while three compartments are necessary for size 6-32 which is more often used, etc.

SELF-TAPPING SCREWS which tap their own holes in steel or aluminum, ideal for screwing down panels to metal boxes, fill one compartment.
BRASS WOOD-SCREWS of different lengths and finish fill a compartment.

BLACK BAKELITE BOLTS for insulating. The perfect thing for keeping voltages from the face of the panel, and for r-f coil supports to remove eddy-current losses. Other black 6-32 screws are included for matching black panels.

SOLDERING - LUG assortment fills another compartment.
Miscellaneous Compartment contains assorted set-screws for knobs, insulating collars for binding posts and shafts on metal panels and other useful difficult-to-obtain pieces.

Price . . . \$1.50 net
in United States and Possessions
Foreign countries . . . \$2.00
Shipping weight . . . 3 lbs.

RELIABLE RADIO CO., 145 W. 45th St., New York, N. Y.

ROLAND BURKE HENNESSY
Editor

HERMAN BERNARD
Managing Editor

RADIO WORLD

REG. U.S. PAT. OFF.

The First and Only National Radio Weekly
THIRTEENTH YEAR

J. E. ANDERSON
Technical Editor

J. MURRAY BARRON
Advertising Manager

Vol. XXV.

MARCH 24th, 1934

No. 2. Whole No. 626

Published Weekly by Hennessy Radio Publications Corporation, 145 West 45th Street, New York, N. Y.

Editorial and Executive Offices: 145 West 45th Street, New York

Telephone: BR-yant 9-0558

OFFICERS: Roland Burke
Hennessy, President and
Treasurer.

M. B. Hennessy, Vice-President.

Herman Bernard, Secretary.

Entered as second-class matter March, 1922, at the Post Office at New York, N. Y., under Act of March 3, 1879. Title registered in U. S. Patent Office. Printed in the United States of America. We do not assume any responsibility for unsolicited manuscripts, photographs, drawings, etc., although we are careful with them.

Price, 15c per Copy; \$6.00 per Year by mail. \$1.00 extra per year in foreign countries. Subscribers' change of address becomes effective two weeks after receipt of notice.

CHOICE CIRCUITS FOR SHORT WAVES

By Warren P. Lester

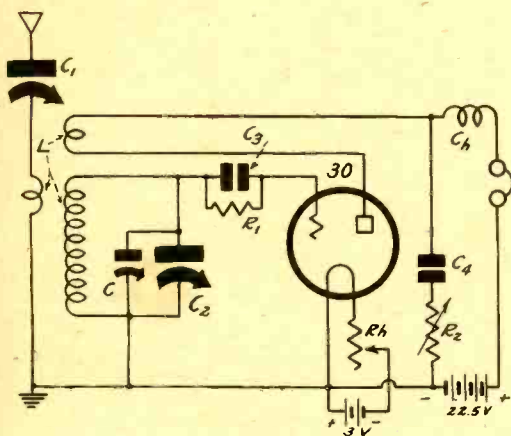

FIG. 1.

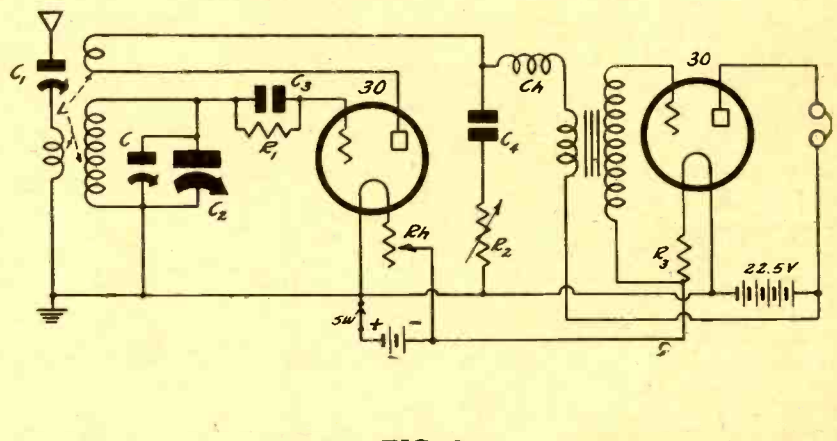

FIG. 2.

A typical short-wave, regenerative receiver for battery and earphone operation, and the same short-wave set with a stage of audio.

SHORT-WAVE receivers may contain any number of tubes, from one up. Just how many there should be depends on several factors, the sensitivity required, the money available for the set, and the type of tubes used being a few of them.

If a single tube like the 30 is selected, the circuit must be strongly regenerative, and the regeneration must be closely controllable. Very good results can be obtained with such a receiver. For illustration we show the circuit in Fig. 1. It is a typical circuit of the tickler variety. The coil is of the plug-in kind and has three windings. One small winding is connected in the antenna circuit, the other in the grid circuit, and the third in the plate circuit. In series with the antenna winding is a condenser C1, small and variable. This is a very important feature in any short-wave set, for it helps to adapt the antenna to any short wave to which the tuner may be adjusted.

Control of Regeneration

Regeneration is controlled by means of a variable resistance in the plate circuit, that is, in series with the tickler winding. A resistance of about 50,000 ohms will do

here, usually, but it depends on the coil system L, the filament current, and on the plate voltage. With normal filament current any coil system will oscillate with as high a resistance as 50,000 ohms for R2 but if the regeneration is too strong to be easily controlled, a simple way of reducing it is to decrease the filament current by increasing the resistance in Rh.

Condenser C4, which may be of 0.0005 mfd., is used only for the purpose of preventing direct current from flowing through the variable resistance below it. The choke, Ch, should have a value of about 10 millihenries and a very low distributed capacity. Without this choke the oscillation cannot be controlled because the high frequency current can flow through the capacity of the headphones.

The value of the grid condenser, C3, should be the same as that used at broadcast frequencies, although it may be somewhat less. The grid leak, R1, may also have the same value as when it is used for broadcast reception. The reason why they may have the same values in a short-wave receiver and a broadcast set is that the function of these devices is the same regardless of the frequency of

the signal. They operate between a high frequency and audio frequencies, and the audio frequencies are the same all the time.

The usual values for C3 and R1, respectively, are 250 mmfd. and 2 megohms, but they are not critical. For very weak signals it is well to use a high value of leak resistance, for a high value will improve sensitivity. A value of 100 mmfd. is suitable for C1 and a value of 140 mmfd. for C2. C should be a very small vernier condenser of about 25 mmfd. maximum capacity, or even less. The object of this condenser is to provide band spread tuning, or very fine adjustment of the tuning.

A Two-Tube Receiver

If we wish to have a little greater sensitivity than that afforded by a single regenerative tube, the simplest way to get it is to add a stage of audio frequency amplification. This has been done in Fig. 2. The only change in the first stage is that the primary of the audio frequency transformer has been substituted for the headphones. The audio amplifier contains a single 30 type tube and the headphones have been placed in the plate

(Continued on next page)

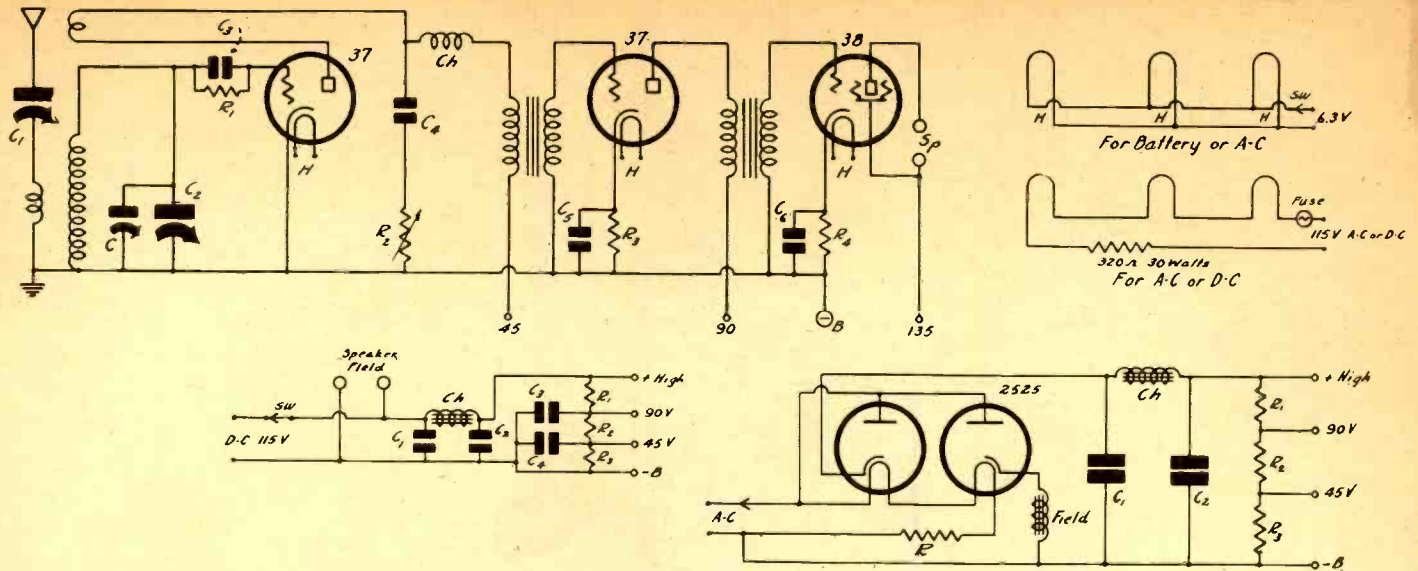

FIG. 3.

Upper left figure shows a regenerative short-wave receiver with two stages of audio added. Upper right shows two connections for the filaments, one series, the other parallel. Lower part of figure shows B supplies for d-c and a-c lines.

(Continued from preceding page)

circuit of this tube. The grid bias on the output tube is obtained from the drop in R_3 , which is one voltage when the supply voltage is 3 volts. Since the filament current normally is 0.06 ampere, the resistance should have a value of 17 ohms. However, since headphones are supposed to be used, it will be all right to use a fixed resistance of 20 ohms. Incidentally, the minimum value of R_h in the first tube, both in this circuit and in the preceding, should not be less than 20 ohms. For this reason it is recommended that a fixed resistance of 20 ohms be put in a series with the rheostat as a precaution against damaging the tube.

It is often said that a stage of audio frequency amplification does not increase the sensitivity, only the volume. Of course, there is no difference, provided that by volume we do not mean volume handling capability. Amplification increases sensitivity regardless of the frequency level at which the amplification is accomplished. The audio transformer in this instance can have a ratio of 5-to-1 and the second tube has an amplification of at least 6, making a total step-up by the added stage of about 30. The extra does not add any to the difficulty of tuning nor to the difficulty of stabilizing the circuit.

If still more volume is required, that is, enough for a small loudspeaker, it can be obtained by adding still another tube, which now should be a power tube. Up to the plate of the second tube the circuit in Fig. 3 is the same as that in Fig. 2, in so far as the signal circuit is concerned, but different tubes have been used. It is not practical to run a power tube on small batteries and for that reason it is well to select tubes that can be operated on any kind of current on the filaments. Therefore, in Fig. 3, the first and second tubes are 37s and the last tube is a 38.

The voltage on the plate of the regenerative tube is 45 volts, that on the plate of the second is 90 volts, and the screen and plate voltage on the power tube is 135 volts. R_3 may have a value of about 1,500 ohms and R_4 600 ohms.

At the right of the circuit in Fig. 3 are two different arrangements of the filaments of the three tubes. The one on top is for the case when the heater current is taken from a 6-volt storage battery, all the filaments being connected in parallel. This arrangement can also be used when the supply is a-c and 6.3 volts. That is, if a filament transformer giving 6.3 volts is available, it can be used for heating the filaments. The lower filament circuit shows all the filaments con-

nected in series, and this arrangement may be used on any 110-120 volt line, a-c or d-c. A simple series circuit is all that is required for all the tubes take the same filament current, namely, 0.3 ampere. If we assume that the average line voltage is 115 volts, the voltage that must be dropped in the ballast resistor is 96.1 volts. Hence the resistor should have a value of 320 ohms. This resistor should have a rating of at least 30 watts.

B Supplies

When the circuit in Fig. 3 is used on batteries for the filaments, batteries naturally will have to be used for the plates, but when it is used on a power line one of the arrangements shown in the lower part of the figure can be used. On a d-c line the arrangement at the left is suitable. A filter consisting of one 30-henry choke, Ch , and two condensers, C_1 and C_2 , is used for taking out the ripple. Values of 4 mfd. for the condensers are all right and it is preferable to use non-inductive paper type condensers. However, electrolytics may be used, and then they may be larger. Polarity must be observed if the electrolytics are not of the non-polarized type.

The proper voltage division is obtained by means of three resistances, R_1 , R_2 and R_3 . The values of these resistances should be, respectively, 1,200, 5,000 and 5,000 ohms. Condensers C_3 and C_4 need not be larger than 2 mfd. each.

Provision is made for the field of the loudspeaker by merely bringing two leads from the line to a pair of terminals. Of course, if the speaker is built into the set, the connection can be made direct without the terminals. The speaker to be used should be designed for a 38 tube and a field voltage of 110 volts.

When the circuit is to be used on a-c lines, the power supply circuit should take the form shown at bottom right in Fig. 3. A rectifier of the 25Z5 type is required. Since this tube has two independent rectifiers, one of them can be used for supplying the current for the loudspeaker field and the other for supplying the current for the plate circuits of the tubes. The field is simply connected between one of the cathodes and one side of the line. No filtering other than that afforded by the field coil itself is absolutely necessary. However, a condenser of about 4 mfd. can be connected across the field coil. This will not only help to stabilize the field current but it will also increase the field current.

The other cathode of the rectifier is connected to the B supply filter in the

regular way, and the filter used is the same as that in the d-c B supply. Condensers C_3 and C_4 have been omitted from the drawing, but they should be used.

If this B supply is used directly on the line as indicated, the ballast resistor R should have a value of 300 ohms, with a wattage rating of 30 watts. However, when it is used in conjunction with the circuit at the top of the figure it is more economical to utilize the drops in the filaments of the receiver as part of the ballast. The filaments of the three amplifier tubes and that of the rectifier are connected in series and the ballast resistor is made 240 ohms, with a wattage rating of 25 or more.

Coil System

In each of the three circuits above there is a single coil system. To cover the short-wave band it is necessary to have some means of changing the inductance. The most convenient way of doing this is by means of plug-in coils. Standard coils for the specified tuning capacity can be used. Since there are three windings on the coil, and since two of the terminals are grounded, there will be five independent connections. Therefore the socket should have five springs and the coil forms should be of the five-prong variety.

With a tuning capacity of 140 mmfd., a set of four plug-in coils will be required to cover the short-wave band from 200 meters down to the shortest the reception of which is ordinarily attempted. If broadcast reception is also to be provided for, two additional coils are necessary. These coils are all obtainable as they are made by nearly all coil manufacturers.

When really high sensitivity is required without the troubles of close regeneration adjustment, the only circuit that is practical is the superheterodyne. In Fig. 4 we have the diagram of a five-tube super employing battery tubes. The first is a 1A6 mixer tube, which serves the dual purpose of oscillation and detection. The second tube is a 34 high gain amplifier, the third is a grid bias detector, the fourth a 30 audio amplifier in a resistance coupled setting, and the final tube is a 33 type power amplifier.

The circuit has only two intermediate frequency coils, with one intermediate frequency amplifier, because in most sets using more there is difficulty stabilizing the circuit. It becomes necessary, as a rule, to introduce losses so that when stability has been achieved, the circuit is no more sensitive than it would have been with one amplifier and two doubly tuned intermediate frequency transformers.

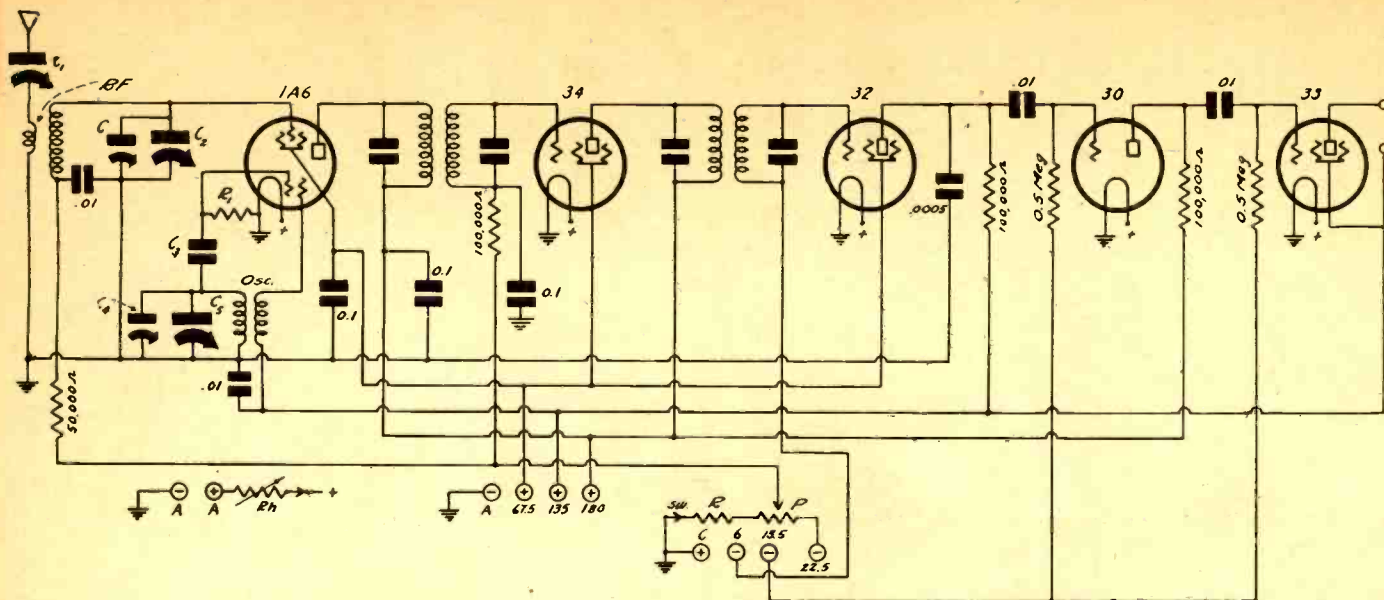

FIG. 4

This is the circuit of a five-tube short-wave superheterodyne employing battery type tubes. Resistance coupling is used in the audio amplifier and a 33 type output tube, which gives sufficient volume to operate a loudspeaker. Volume is controlled by means of grid bias variation.

The 32 is operated as a grid bias detector, with a bias of 6 volts. In its plate circuit is a 100,000 ohm resistor and a by-pass condenser of 0.0005 mfd. The 30 is coupled to the detector by means of a 0.01 mfd. condenser and a 0.5 megohm grid leak. This tube is given a grid bias of 13.5 volts, which is normal for the plate voltage applied. Another resistance-capacity coupler consisting of a plate resistor of 100,000 ohms, a coupling condenser of 0.01 mfd., and a grid leak of 0.5 megohms.

The 33 power tube is given a bias of 13.5 volts and a plate and screen voltage of 135 volts.

The bias for all the tubes is provided by means of a 22.5-volt grid battery. The grid return of the detector is connected to the 6-volt tap and the grid returns of the two audio amplifiers to the 13.5-volt tap. To provide a variable bias of a maximum value of 22.5 volts on the mixer and intermediate frequency grids, a potentiometer of 25,000 ohms is connected across the 22.5-volt battery. The grid returns of the two controlled tubes are connected to the slider. A minimum bias is set by a fixed resistance R at the positive end of the potentiometer. This should have a value of 2,000 ohms.

A resistor of 50,000 ohms is connected

in the mixer grid return and one of 100,000 ohms in the i-f amplifier lead. These are for the purpose of preventing feedback. In conjunction with the i-f tube there is a 0.1 mfd. by-pass condenser and in conjunction with the other a condenser of 0.01 mfd.

Plug-in coils are recommended. If usual tuning condensers are employed, say 140 mmfd., standard coils are available both for the oscillator and the r-f tuner. The two main condensers should be ganged, and this as well as the fact that band spread is necessary, requires that a small trimmer be connected across each variable condenser.

A DX Broadcast Tuner

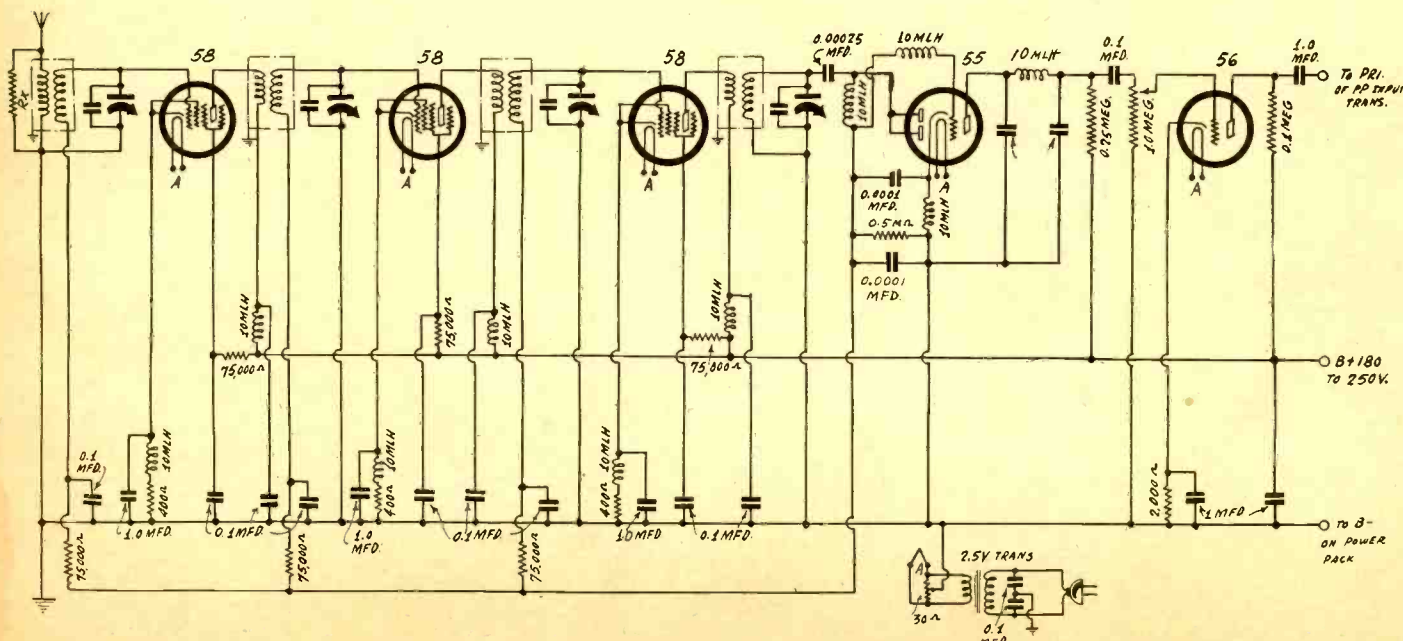

How can a diode detector be used when the tuned circuit immediately in front of it has a condenser that is part of a gang the common rotor of which is grounded? We have heard it said that it is impossible to do it without shorting something. If that were impossible, there would not be many things in radio that could be done. If you glance at the circuit above you will note that there are four condensers all

told, all having a common rotor, and the last of them is in the tuned circuit that feeds the diode detector. The first thing to do is to ground the condenser and the coil which it tunes. Then put a small condenser, 0.00025 mfd. in this case, between the diode plates and the top of the tuned circuit. That provides a path for the high frequency currents. A path must now be provided for the rectified current.

That is done by putting a choke between the diode plates and the load resistor. That chokes not only serves to provide the path for the rectified current but it also helps to smooth out the ripple. In this circuit is a 10 millihenry choke coil in the cathode lead.

This is not essential to the operation. It might be used as an additional filter to considerable advantage.

Leak-Condenser Detector and Diode Are the Same

By J. E. Anderson

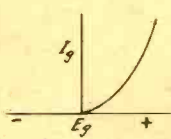

FIG. 1
The relation between the grid current and grid voltage in a thermionic triode.

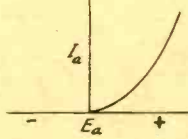

FIG. 2
The relation between anode current and anode voltage in a diode rectifier.

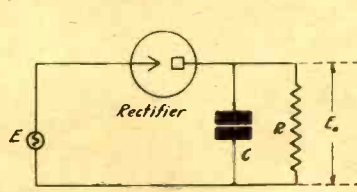

FIG. 3
A simplified rectifier circuit using any rectifier. E is the a-c voltage applied and E_o the d-c output voltage.

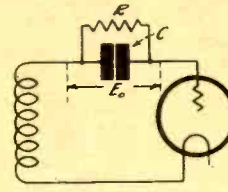

FIG. 4
The grid leak and condenser detector is a diode rectifier of the same type as that in Fig. 3.

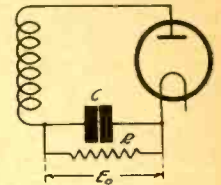

FIG. 5
The diode rectifier as shown here differs in no essential from that in Fig. 4. Both are diode rectifiers.

WE have stated a number of times that detection by means of grid leak and condenser is identical with detection by means of a diode rectifier. Our statement has been questioned on the ground that different explanations are used in expounding the two. In one case "trapping" of electrons has been wrung in to clarify the subject and in the other it is usually stated that pure rectification is involved. It is not difficult to prove that the two are identical regardless of what method is used for explaining the operation.

First of all, let us forget all explanations of how either type of detector operates, for then we are better able to judge whether or not the two are the same.

Fig. 1 represents the relation between the grid current and grid voltage on a triode when the microammeter, or milliammeter, is connected in the grid circuit and the voltage is applied in series with the meter and the grid. Current flows only when the grid is positive, at least to any appreciable extent. At first the current is nearly proportional to the square of the voltage, but that particular variation of the current is of no consequence right now. The point is that the current increases with the voltage and that it flows only when the grid is positive.

The Diode Rectifier

Now look at Fig. 2. This represents the variation of the current in a diode rectifier as the anode voltage E_a increases. It will be noticed that the current varies in exactly the same way as it did in the preceding case. So far, then, the only difference between the grid rectifier and the diode rectifier is that in one case the anode is called a grid and in the other it is called an anode, or a plate. Regardless of the physical shape of the positive element, it is an anode when it is positive and it draws current. Usually, the anode in a grid rectifier takes the form of a grid and in the other case it takes the form of a solid electrode. It may be a plate, a cylinder, a simple wire placed near the cathode, or it may be a grid. The shape does not matter; the important thing is that it be positive and that it be near the cathode.

In Fig. 3 we have a simple rectifier circuit consisting of a source of alternating voltage E, a rectifier element, a load resistance R, and a condenser C. The rectifier element may be of any type, the grid of a triode, the plate of a diode, a crystal, or any other unidirectional device. The most familiar case is that of a rectifier circuit used for supplying the d-c power to a radio receiver, that is, the ordinary B supply. What

is true for the B supply rectifier is also true for other types, such as the diode used for detection and the grid used for the same purpose.

Suppose that in Fig. 3 the condenser is omitted. The voltage E will cause a current to flow around the circuit, through the resistance R whenever the direction of the voltage is such that current can flow. In the case of the diode it occurs when the anode, or plate, is positive with respect to the filament or cathode. The current, then will be in the form of unidirectional pulses. Now suppose that we connect a high resistance voltmeter across R. It will show a certain voltage E_o , and this is the mean value of the voltage drop across R, which now includes the resistance of the meter. As a matter of fact, only the voltmeter need be used. This voltage will appear regardless of the frequency of the voltage E. In B supplies it is usually 60 cycles per second; in a detector it may have any value.

Function of Condenser

Now let us connect the condenser C across the voltmeter, or across the resistance R. It will be found that the value of E_o increases. How is that, if we did not increase the Voltage E? The voltmeter, or R, or the combination, has a high impedance. Therefore the current pulses will be weak and so will the mean value be. Not much average current flows through the high impedance and therefore the voltage reading will be low. But when the condenser is connected across the impedance, the impedance to the pulses of current will be low. Hence the pulses will be strong, and the mean value of the pulses will also be high. Therefore the meter deflection will be greater. The condenser acts as a reservoir which accepts the strong pulses and discharges them slowly, making the average current high because current flows through the resistance all the time.

If the meter is not present, the voltage will appear across the resistance anyway, and it will be a little higher. As long as the amplitude of the voltage E remains constant, the mean value of the current through R will be constant. It will still be pulsating, for it will rise when the rectifier conducts and drop slowly while it is not conducting. This variation will be less the larger the capacity C. It will be less still if a choke be connected in series with R, for this choke will prevent rapid discharging of the condenser and it will also prevent the rise in the current during conductive periods, forc-

ing the extra current into the condenser. This applies to any type of rectifier circuit.

Grid Leak Detector

In Fig. 4 we have the usual grid leak and condenser type of detector. The load resistance R is placed next to the anode and the source of alternating voltage, which is the coil, is placed on the cathode side. As long as the amplitude of the voltage is constant, there will appear a constant mean voltage, E_o , across the resistance and the condenser. There will be a ripple in this voltage, the magnitude depending on the value of R and on that of C. For high frequencies it will be small for the values of R and C ordinarily used.

Now consider Fig. 5, which represents a diode rectifier. The coil, or source of alternating voltage, is placed on the anode side and the load resistance R and the tank condenser C are placed on the cathode side. The voltage E_o will appear across the condenser resistance combination as in the other case. There is an apparent difference between the two cases here, but it is not a difference in operation but merely one of convenience. Perhaps it is not a matter of convenience either, but merely one of common practice. It becomes a matter of convenience only when a tuning condenser is put across the coil and when this condenser must be grounded. In that case the coil should be placed on the cathode side. When the condenser does not have to be grounded, as in the case of a superheterodyne, the coil can be, and usually is, placed on the anode side.

So far there has been no difference between the two detectors in principle of operation, only slight difference in the arrangement of parts.

Production of Audio Signal

Suppose now that the amplitude of the signal varies at a certain rate. Let it first change by a fixed amount, say 10 per cent. down. The voltage E_o then changes downward by the same amount. If it changes upward by 10 per cent., E_o increases by the same amount. This is true in the B supply and it is equally true in the detector. If the change is gradual from one value to another, the value of E_o will vary gradually in the same manner. The signal voltage amplitude might vary sinusoidally in such a manner that at the peaks the value of E is 30 per cent. higher than the mean value and so that at minimum it is 30 per cent. lower than the mean. The value of E_o will

then vary in the same manner, varying gradually between the limits $1.3E_0$ and $0.7E_0$, where E_0 now is the mean value. The signal is then modulated 30 per cent. and the output voltage of the rectifier, as it appears across the condenser and R, has an amplitude of $0.3E_0$. That is the detected signal, or rather the amplitude of it. It holds, of course, for any linear detector whether the anode is called a grid or a plate, or whether it is one or the other.

Amplification

A slight difference between the two types of detectors occurs when the detected signal is applied to the audio amplifier. In the grid leak type of diode detector the anode serves as control grid for the audio amplifier. It is not until this stage is reached when the grid may properly be called a grid, for it is not until then when it performs the function of a grid. It controls the plate current of the triode. The reason that the grid leak type of rectifier cannot handle as much signal voltage as the diode type is not that the grid as rectifier cannot handle it but that the plate cannot handle it. In order that the grid leak type of detector-amplifier should give greatest response, it is necessary that plate current grid voltage characteristic be such that the point of operation is at the steepest point.

The mean potential of the grid will be slightly negative, equal to the mean potential drop across the grid leak, and this bias must coincide with the steepest point on the grid voltage plate current characteristic. With the usual signal strength, that is, the usual value of E , requires that the plate voltage be in the neighborhood of 45 volts. With 45 volts on the plate, the amplifier cannot handle a strong signal. Of course, the plate voltage could be increased, but this would require an increase in the radio frequency signal amplitude to put the operating point at the optimum value of grid bias.

It is usually said that the grid leak detector "modulates" downward, whereas a plate bend or diode detector modulates upward. The detectors behave exactly the same way in both cases; it is the detector and audio amplifier stage that behave differently from the detector alone.

Diode Detector

When the so-called diode detector is used in connection with an independent audio amplifier, as is the case with the 55 duplex diode triode, we have grid leak type of detection when the control grid of the triode is connected to the negative end of the load resistance, for then the anode and the control grid become one as far as the audio frequency potential is concerned. They would be the same exactly if the control grid were connected directly to the anode. The only difference here, then, is that in one case the radio frequency signal is amplified more than in the other case, and that is advantageous when regeneration is employed, not only advantageous but essential.

In the diode biased detector-amplifier, the bias on the triode is proportional to the strength of the incoming signal, just as it is in the case of the grid leak type of detector. But the diode biased detector can handle a stronger signal because there is a much higher plate voltage on the triode. The plate voltage is so high and the cathode emission so copious that the triode will amplify well even when the bias is nearly zero, although this may not be the optimum operating point. That is why the diode detector-amplifier works on weak signals. It also works on strong signals because of the high plate voltage. But there is a limit here, too, and that happens when the radio signal amplitude is so strong that the mean value of E_0 , which is due to the unmodulated carrier, approaches the value of the cut-off bias of the triode. How near it may approach without causing appreciable distortion depends on the percentage modulation.

If we have fixed bias on the control grid

Winner on Air Tells About Expedition Communication



Lewis Winner (at right), recording the results of tests made of short-wave equipment aboard the ship of Capt. "Bob" Bartlett, explorer.

Communication work on high frequencies, by exploration and discovery expeditions, was described by Lewis Winner, radio advertising writer, in the first of a series of talks by him broadcast from WBNX, New York City.

Mr. Winner in his opening talk told of the improvement made in the last seven years in such communication work and stressed the importance of reliable and uninterrupted service in expedition work. He told experiences of some of the chief adventurers of the present day and said that high-frequency communication has proved to be the missing link.

Mr. Winner dealt considerably with the

experiences of Capt. R. A. ("Bob") Bartlett in connection with the Bartlett-Norcross Arctic trip of last Summer. The radio installation aboard the Morrissey, depicted the illustration herewith, played an important part in the success of the expedition.

Bob Moe, who operates W2UN, New York City, was the radio man aboard. He made a special study of reception conditions in the Arctic.

The transmitter was a 500-watt outfit for continuous-wave transmission. The receiver was a seven-tube battery-type Hammarlund "Pro." The 40- and 20-meter channels were used. Mr. Moe found that temperature did not affect reception.

of the duplex diode triode, we have merely a diode detector and an amplifier, and the two parts might as well be separate tubes. However, it is more convenient to use a common source of electrons for the two.

The statement that grid leak-condenser detection is the same as detection and amplification by a diode biased tube, like the 55, has been demonstrated, we believe.

Both Become Negative

It has been asserted that a difference exists between the two on the ground that in the grid leak detector the grid grows gradually negative so that no current can flow, and that the same effect does not occur in the diode rectifier. If the two rectifiers are the same, the same course of events must follow. The fact is that in both the grid, or the anode, becomes negative. If it did not, there would be no detection. Rectification need not take place over an entire half period. It does not. Only the peaks of the signal succeed in driving the grid, or anode, positive. There must be some rectification in every cycle, however, or there will be no current pulses to sustain the leakage through the load resistance.

Police Calls Reassigned Effective as of May 1st

Washington.

Eight states and 128 municipalities are now equipped with their own radio police communication systems, involving equipment of more than 4,000 police cars with receiving sets, according to a recent statement of the Federal Radio Commission.

To provide for rapid expansion of police radio systems, the Commission has made a new allocation of state and municipal police frequencies, effective May 1st, providing twenty channels for police radio with additional frequencies authorized by the recent Mexico City radio conference. Five kilowatts of power for daytime transmission and one kilowatt at night is a limitation imposed on police radio by the Commission which characterizes the progress and expansion of the police systems as "one of the real dramas of radio."

An A-C Operated Earphone Three-Tube Set

for Short-Wave Reception by Authenticated Means

By Emanuel Mittleman

Try-Mo Radio Corporation

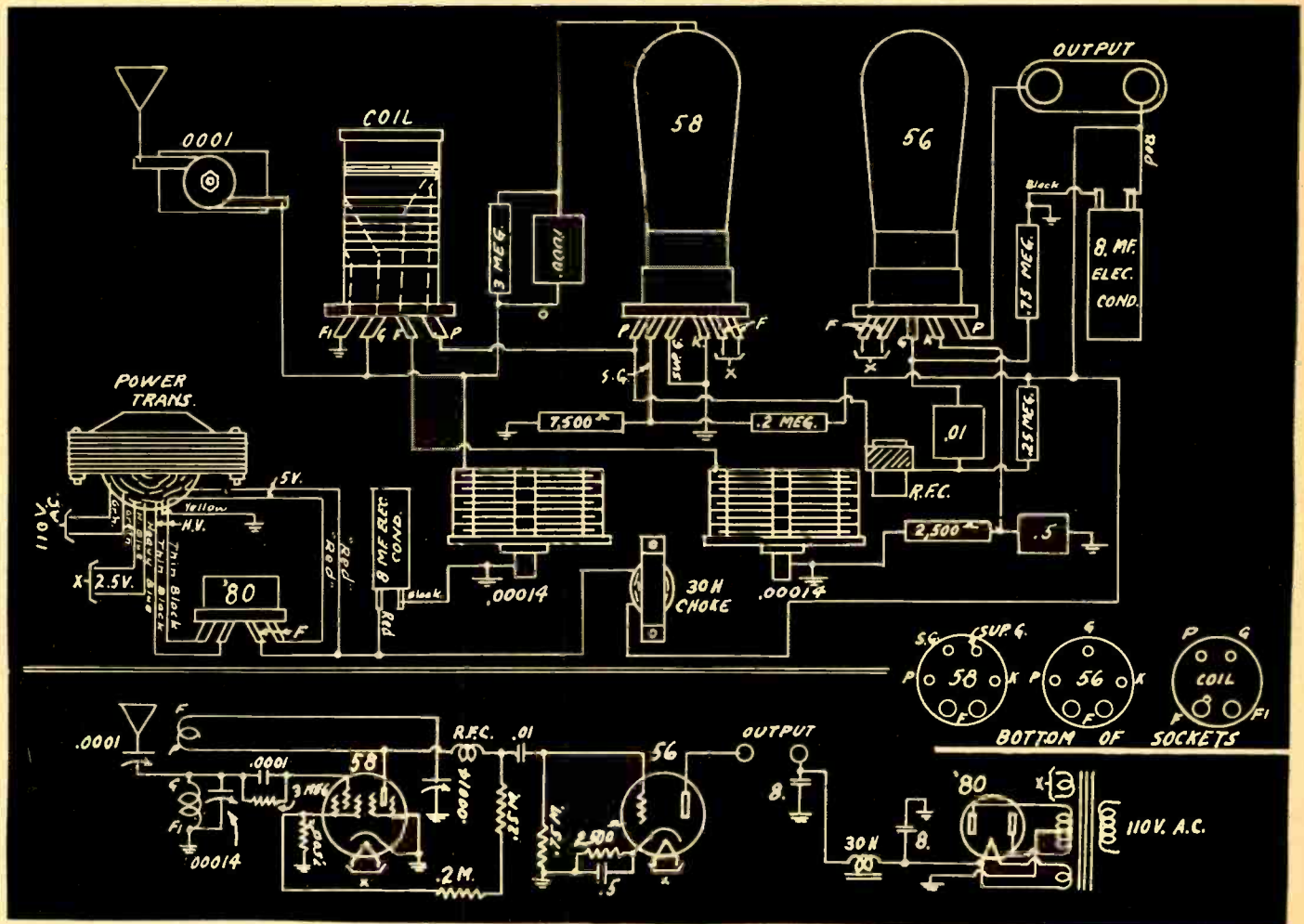

The circuit diagram of a three-tube short-wave receiver, using plug-in coils, and also a pictorial exposition or graphic diagram of the wiring.

THE present activities of the suppliers of parts for short-wave receivers concern largely the mechanical layout, since tried and approved circuits of long familiarity are the rule. To be sure, new tubes have been introduced since the days when the regenerative detector was popular for broadcast waves, and much has been learned about the secrets of short-wave transmission and reception, but the regenerative receiver circuit has not changed essentially, and certainly not since the advent of the present extreme popularity of short-wave listening. However, the random layouts of early days are taboo. The listener wants something attractive to the eye, as well as fruitful of results in reception.

The three-tube receiver under discussion follows the familiar pattern, consisting of a regenerative detector, with one stage of audio, the third tube being the rectifier, so that an a-c operated receiver is enjoyed, and the B supply is in the same housing as the remainder of the circuit.

For some purposes it is advisable to have the B supply external, particularly if the filtration can not be pressed to satisfactory performance without that rather cumbersome alternative. However, by spending some patient hours in the design of the layout, and in electrical testing, as the author did, it becomes of course entirely practical to make the receiver totally self-contained. If it were not practical the highest-priced short-wave or all-wave receivers always would have a separate B supply, whereas not one in that class has the external adjunct, but every such set is self-contained.

After the parts were arranged well, judged on the basis of reception results, and the necessary small circuit changes made to conform to the requirements of excellent sensitivity and adequate selectivity, the circuit, in its electrical and mechanical aspects, was accepted as shown. Since then it has been tried out by scores of short-wave experts and has met with their approval.

The circuit uses a series antenna con-

denser for its pronounced effect on regeneration and for its consequent aid in selectivity and sensitivity. Since there are four bands in which tuning is done (using a total of only four plug-in coils), it may be advisable to set this condenser once for each band, at a position that will be determined experimentally, and then will be recurrently familiar to the user. Smaller series capacity is used, the higher the frequency band, so that in a sense the impedance looking into the first tube is more or less matched to the frequency range under consideration. The crux of the subject is the impedance of the capacity, for at the very highest frequencies the impedance of even the minimum capacity is relatively large. It may be recalled that experiments on waves below 1 meter are frequently conducted with series antenna capacities consisting of a fraction of 1 mmfd., capacities lower than those with which even the most seasoned experimenter is likely to be familiar.

The coil need have only two windings,

Automatic Volume Control Valuable for Short Waves

of which one is in the tuned circuit, in parallel with the 140 mmfd. tuning condenser, the other winding being the fixed tickler. If the plate is led to the tickler and a variable condenser is between low-potential end of the tickler and ground, no direct current will flow through the tickler, and somewhat smoother regeneration control may be expected. Such is the circuit used, the audio component being led through a high-inductance choke coil, which serves to keep the radio-frequency currents out of the audio amplifier, and also, by the same token, as a protector or insurer of the regenerative action of the throttle condenser.

There are several methods of controlling regeneration, and practically all of them are good, though it must be said in all truth that the throttle condenser method is the favorite one, and since the jury has spent years as short-wave enthusiasts, and know their onions, we do well to pluck vegetables from the garden of the favorites.

58 Tube as Detector

The 58 tube is used as the detector because it detects well and is somewhat quieter than the 57 in this circuit. It need not be assumed that a remote cutoff tube is not a good detector, despite the theoretical considerations, for when the leak-condenser method of detection is used the 58 rises to the same high rank of general performance as does almost any other type of tube, even tubes more frequently shown as detectors. There are considerations just as important as sensitivity, and quietness is one of them. For instance, what fun is it to work a set that develops a howl when one is operating just on the borderline of oscillation in the detector? The 58 was found to be freer of this trouble than the 57.

Fringe Howl

A word about this fringe howl, which may be present in any short-wave receiver. It is likely due to some mechanical oscillation. Therefore a satisfactory method of curing the trouble is to put a 50,000-ohm resistor across the phones, whereupon the trouble may be expected to disappear, and then with a hammer lightly tap various parts of the receiver until the point is found where the howl may be introduced by this tapping. In fact, a tap or two in the critical spot will act as a sort of trigger, and the receiver may go on howling, but you know the location of the trouble, and will tighten up the loose part, and not introduce some sensitivity-robbing device that also gets rid of the trouble, but, oh, at what expense to sensitivity! Remove the resistor after the cure.

The B Supply

The B voltage divider consists of 207,500 ohms, of which 200,000 ohms are between cathode and ground and in the detector circuit, to contribute a small bias, and 200,000 ohms are between cathode and B plus. The reason for the slight bias is to limit the amount of grid current on strongest signals, that is, a precaution in the direction of prevention of easy overload, and also to remove some of the abruptness of the curvature in the regeneration characteristic. That is, the operating point is shifted a bit.

The detector is resistance-coupled to the 56 audio tube, and the output is taken from earphones in series with the 56 plate and B plus.

The circuit diagram is given in the illustration, and also a pictorial diagram of the wiring is presented, so that any novice can build the receiver successfully. The coils are standard, the tuning condensers are likewise, and the whole outfit conforms to the dictates of experience, instead of being theoretical and experimental.

The diode detector, so popular now, is the best so far developed for commercial use. In the 55, for instance, there are two tubes in one envelope, and most often full-wave diode detection is used. In supers, for instance, the diode is effective in converting the intermediate frequency signal into an audio signal. It converts efficiently and, above all, faithfully. It is not a respecter of frequencies to any marked degree but treats the high and the low with impartiality. This, of course, is essential if the output of the receiver is to be of as high quality as that of the signal that went into the transmitter at the far distant place.

Audio Service

The second function of the detector tube is that of audio amplification. It steps up the audio signal voltage developing across the diode load resistance in the ratio of about seven to one. Now, the triode of the 55, which does the voltage stepping-up, is diode biased and it is coupled to the final tube in the circuit by resistance and capacity. Therefore there is no frequency discrimination in this part of the circuit either. The signal is delivered to the output tube's grid with unimpaired fidelity.

Then it devolves on the output tube to do a good job, not only in stepping up the signal still further but doing so without spoiling the quality. To give this tube a chance to do its work properly it is necessary to apply the correct voltages on its various elements. It must have the correct bias, the correct screen voltage, and the correct plate voltage. The correctness of these voltages is assured by the return of the leads of these elements to the power supply. The adjustment should be the result

of experiment on an actual circuit and not of theoretical design.

Automatic Volume Control

In any short-wave receiver that is to pick up foreign stations there must be an automatic volume control, for otherwise the signals will come and go as they please. One minute they will be so strong that the speaker will jig-dance, the next they will be gone entirely. But with an automatic volume control such as is used in this circuit, there will be no noticeable variation in the intensity of the received signals as long as the amplitude of the fading is not abnormally high.

Another feature that is essential in a short-wave set is a trimmer on the radio-frequency tuner by which tuning can be done in fine gradations with absolute certainty. A good circuit is provided with such a trimmer.

"Virtual" Stations

When a short-wave receiver of this kind is used and a log is made of all stations received, that log looks very much like an international list of short-wave stations, and about the only ones missing are those that are merely licensed to operate but in fact are off the air. There is a surprisingly large number of these "virtual" stations on the air. But for all that, there are many more to select from, for the total number of active short-wave stations throughout the world is very large. The three principal countries in Europe from which short-wave signals arrive dependably in this country are England, Germany, and Spain.

Ship Doctor Thrilled By Pacific Reception

"From our ship, moored dock-side at Yokohama, Japan, at 11:00 p.m. and to the accompaniment of pattering ricksha feet in the darkness just outside, American radio stations can be heard broadcasting their opening programs of 7:00 a.m. of the same day, sixteen hours after they are put on the air."

Thus states Dr. C. E. Reddick, surgeon of the American Mail Liner *President Grant*.

"One night's steaming time out of Yokohama and 4,200 miles from our Seattle home port I have had short-wave police calls from Portland, Ore.," he says. "It is in mid-Pacific, however, that most of the thrills are provided—that is after 10:00 p.m. when the horde of Japanese broadcasting stations goes off the air. From Nanking, capital of China, come world news flashes given by a Chinese announcer speaking in English. One Russian station specializes in symphony orchestra concerts, while from Australia and New Zealand come programs of all kinds

and once a small up-country station announcing a fire and calling for volunteers to put it out. A thousand miles west of Victoria, B. C., and Cape Flattery, American stations in Chicago, Salt Lake City, St. Louis, Minneapolis, Omaha, Dallas, Fort Worth and a Canadian station at Calgary, Alberta, come in as distinctly as they do locally. At 4:00 a.m. Sunday, January 21st last, as we were nearing Victoria, B. C., I heard a program of welcome being broadcast to the officers and passengers of the SS. *President Adams* at 8:00 p.m. of the same day, or sixteen hours before the program was actually given. The liner was just entering Manila harbor and the station was that city's KZRM."

Dr. Reddick's radio is a small 5-tube table set of a type manufactured in the United States. He explains that all foreign stations in the Orient announce their call letters in English and that their different nationalities can thus be determined easily.

"Shakespeare Theatre" Produced by Vivian

Percival Vivian, for nearly twenty years one of America's leading stage directors, will produce the "Shakespeare Theatre of America" series for WHOM, New York City. The dramas are broadcast daily except Sunday, from 3:00 to 3:30 p.m., a different play being presented each week.

Mr. Vivian, a native of London, Eng., has played ninety-seven Shakespearean roles in Sir Philip Ben Greet's company, and was associated with the David Belasco productions, for five years, during which time he

cast and directed "Lulu Belle" on the Pacific coast and received the plaudits of critics and public alike.

Last season Mr. Vivian produced and directed fifteen of Shakespeare's plays at the Jolson Theatre during a twenty-eight weeks' season. He will soon start a new series of stage presentations at the Venice Theatre, 59th Street and Seventh Avenue, under the management of Clemente Giglio. The first play, both on the stage and on the air will be *The Merchant of Venice*.

A-F VOLUME CONTROL

WELL-CONSIDERED METHODS THAT LOOK TO RESULTS RATHER THAN TO LOWEST POSSIBLE COST

By **Morris N. Beitman**
Engineer, Supreme Sound System

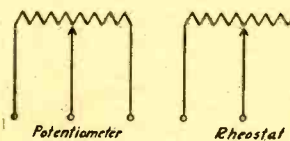

FIG. 1
 Two types of variable resistances

WHERE the audio power must be reduced in the audio amplifier, this is accomplished with the aid of attenuation networks built up of resistive branches. Various other methods may be used to regulate the power level. Varying the biasing voltage on the condenser microphone or the voltages on the plate or grid of one of the tubes would serve the same purpose. However, this is poor practice, for such elements are designed to give the best results with the least distortion when used with stable electrical values. Resistance network may be used for attenuation purposes without adding accountable distortion.

A circuit possesses capacity, inductance and resistance. Of these three only resistance does not vary over wide limits of frequency and, therefore, must be adapted in the circuit for the purpose of reducing the volume. Although no resistance is possible lacking capacity and inductance entirely, it is commercially possible to manufacture units in which these two electrical characteristics are reduced to a negligible value.

With this in mind we may consider for practical purposes an attenuation network to consist of a combination of resistance elements with one or more variable units. These resistance elements are used to introduce a power loss of value between certain limits when placed in the circuit between some fixed values of input and output impedances. From this it seems that three factors determine the design of the attenuation network at any frequency, namely:

- (1)—Value of power loss between minimum and maximum.
- (2)—External input impedance.
- (3)—External output impedance.

Raising the Performance Plane

Occasionally circuits are encountered where either or both the input and output impedances are in such a relation to the circuit that variation over wide limits in their impedances will not make a material difference in the operation. Under such conditions one or both of the last two factors may be neglected.

The variable unit sare potentiometers.

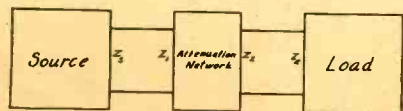

FIG. 2
 Relation of attenuation network to the source and the load. Usually the network is so designed that $Z_s = Z_r$ and $Z_r = Z_L$.

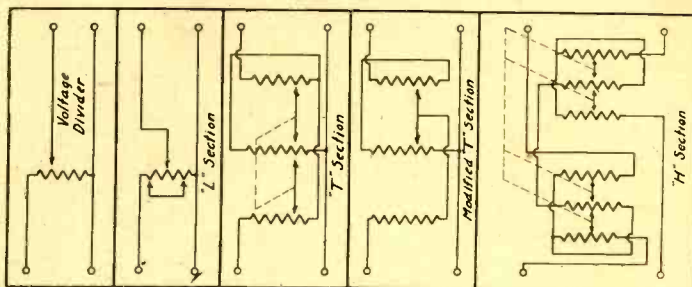

FIG. 3
 Five different types of attenuation networks. The more complex are used when the impedance must be kept constant.

Where only two leads are brought out the unit is called a rheostat. (See Fig. 1.) Since the human ear can not detect a sudden loss of less than 3 decibels, each step should be equivalent to this amount or less. This represents a power ratio loss of two. A wire-wound potentiometer usually has equal resistance per unit of the rotation of the arm. It is an advantage to have the loss occur in equal steps of decibels or power ratios. Wire-wound potentiometers with sliding arms may be made to satisfy this requirement, but the special spacing of the wire is not economical in commercial manufacture. Also as the arm passes off a turn of wire in the unit the slight difference in voltage between the adjacent turns causes a minute arc, which after amplification may appear as audible distortion.

The usual practice to overcome these difficulties is to wind fixed resistances of proper values and bring the connections to an external switching arrangement.

Steps of Fixed Resistances

To satisfy the requirement of negligible frequency changes due to the presence of capacity and inductance, special methods of winding the resistance units are used. Three of the common methods are:

- (1)—On a thin strip a single wire is wound with space equal to the diameter of the wire between turns. The second wire is wound between the turns but in the opposite direction.

- (2)—Wire is wound in the form of a tape where the warp is of cotton threads and the woof is of resistance wire. These are wound like a cloth.

- (3)—Resistance wire is wound on a flat form in a single layer. The thin form and small wire give a very low phase angle.

The attenuation network is placed between the source and the load where the impedances must correspond to the image impedances. See Fig. 2. If these two do not correspond the calibration will be in error.

Numerous combinations of resistances are used in the networks. A few of the more common ones will be described. See Fig. 3.

Voltage Divider—This section must work into a high impedance circuit that draws no current.

"L" Section—Output impedance varies somewhat with the setting. Input constant for all settings if properly designed.

"T" Section—Both the input and output impedances are constant regardless of the setting.

Application of Theory

Modified "T" Section—A "T" section in which one arm remains constant. Attenuation introduced by this section may be accurately computed. The input impedance changes somewhat.

"H" Section—This is equivalent to a "T" section on each side of the line. Reduces errors due to unbalanced ground. Impedance constant at all times.

Having briefly covered the bare fundamen-

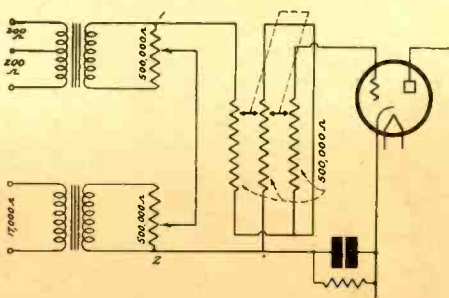

FIG. 4
 A circuit for mixing microphone and phonograph inputs and for controlling the overall volume. The impedance is constant at all volumes.

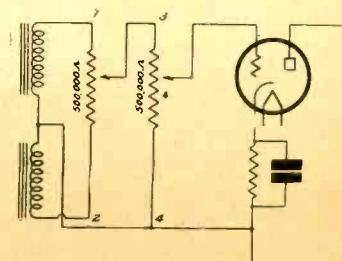

FIG. 5
 A simple circuit for mixing two inputs and for controlling the overall volume, suitable for small public address systems.

tals of attenuation networks, we may apply this information to a few problems in design encountered in public address work.

Control for Small System

As a beginning, a control for a small PA system may be considered having a microphone and phonograph input. Each is coupled to an individual transformer having primary impedance of the proper value to match the input devices' characteristics. The secondaries are of the high impedance type suitable to be coupled to the grid of a vacuum tube. It is well known that it is best to control volume at the very beginning or close to the beginning of the circuit. To accomplish this and succeed in mixing the voice with the phonograph the volume control may be placed between the secondaries of the transformers and the grid of the first tube. Let us assume that it is further desired that the phonograph could be mixed with the voice in any proportion and the total input be varied anywhere between maximum and cut off value.

Fig. 4 illustrates a circuit satisfying all these requirements. The double potentiometer between points 1 and 2 cuts one transformer as it increases the input from the second. Mixing may be done by selecting a suitable point on the potentiometers. The overall control is accomplished with the aid of a "T" section network. Both input and output impedances are constant for all settings.

Reduction of Errors

The network described above will prove too expensive if it is to be utilized for a small-sized amplifier. More economical methods yield less efficiency than needed.

Fig. 5 illustrates another method of accomplishing the required control. Variations in the first potentiometer between points 1 and 2 will cause the two circuits to mix in any proportion desired. The variation of the second potentiometer between 3 and 4 will vary the overall volume. The values of the potentiometers are not critical. The input impedance varies slightly and the output impedance has considerable variation, but since the grid does not draw current this makes little difference.

A four-channel constant-impedance mixer and volume control is shown in Fig. 6. The illustration assumes that the inputs will be from two microphones, a 500-ohm line, and a phonograph. This is a problem in attenuation encountered in the design of a large public-address amplifier or a small broadcasting station. With this mixer any number of the four inputs may be mixed in any desired proportion. The "H" type volume control network reduces errors that might appear in the settings due to an unbalanced ground.

News Plan in Effect; Ends Publishers' Kicks

A change in policy of spot news broadcasts has been effected by numerous stations. The two big chains and numerous independent stations subscribe to the service of the Press Radio Bureau, Publishers National Radio Committee, 551 Fifth Avenue, New York City.

Two reports are supplied daily by the bureau, both 5-minute total summaries of numerous news items, mostly local, one for morning, one for evening. This is the result of the recent squabble over broadcasting of news gathered by others than the broadcasters.

GILMAN APPOINTS MAXWELL

Don E. Gilman, vice-president in charge of the Western division of the National Broadcasting Company, announced the appointment of H. J. Maxwell as his assistant and as manager of station relations, replacing C. L. McCarthy, now assistant manager of KFI and KECA, Los Angeles.

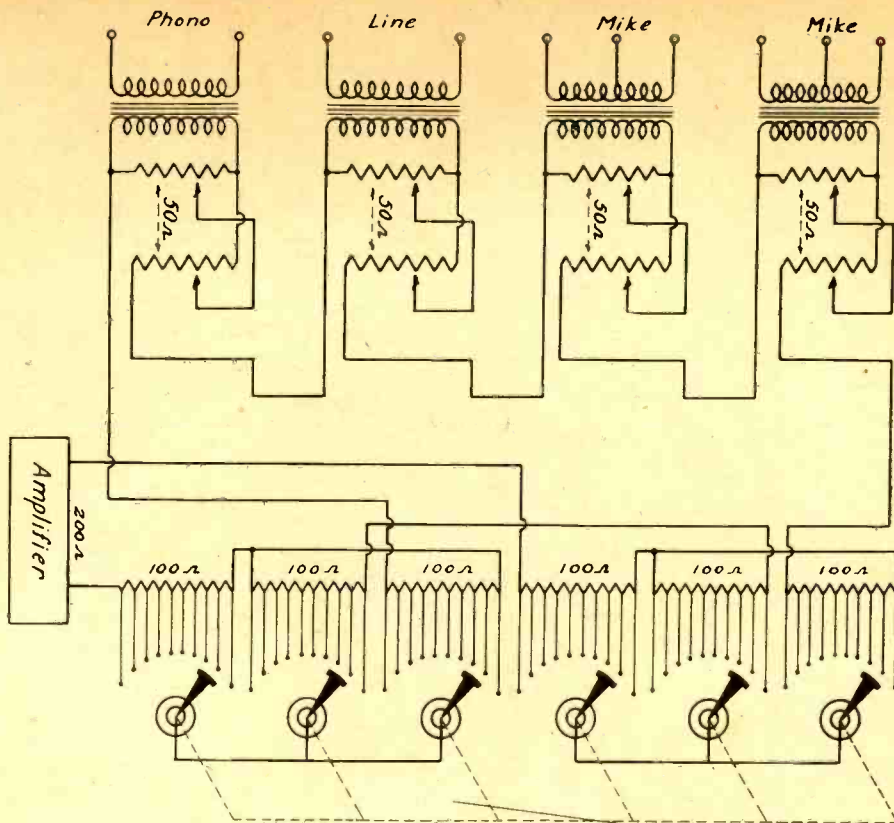

FIG. 6

A four-channel constant-impedance mixer shown schematically. The resistance values specified assume 50-ohm secondaries on all transformers and 200-ohm input impedance in the amplifier. Provision is made for two two-button microphones, a 500-ohm line, and a phonograph pick-up.

Literature Wanted

Readers desiring radio literature from manufacturers and jobbers should send a request for publication of their name and address. Address Literature Editor, RADIO WORLD, 145 West 45th Street, New York, N. Y.

- Harold A. Bogert, 47 John St., Ridgewood, N. J.
- City Radio Service, 524 East Washington, Phoenix, Ariz.
- Chas. Laratta, 458 No. 12th St., Newark, N. J.
- Jos. Belick, 65 Front St., Box 133, Coplay, Pa.
- J. Zink, 1008 North Ave., Wilkensburg, Pa.
- William Gilmore, 1767 17th Ave., San Francisco, Calif.
- Willis Woods, R. F. D. 3, Box 52, Bakersfield, Calif.
- Jack Raley, R. F. D. 1, Box 105, Frost, Texas.
- R. R. Kent, 2nd Ave., Decatur, Ala.
- G. Landfish, E. E., 72 Powell Street, Brooklyn, N. Y.
- Joe's Radio Service, 668 Rees St., Chicago, Ill.
- J. N. Reynolds, R. 3, Clinton, N. C.
- C. L. Kibler, Esmond, No. Dak.
- C. L. Beach, 2624 Webster Ave., St. Louis Park, Minn.
- John K. Thomas, Jr., Box 383, U. of S. C., Columbia, S. C.
- L. L. Curtis, C. K. Radio Service Co., 2750 Midland St., Dayton, Ohio.
- Robt. Smilovitz, Box 418, Carnegie, Pa.
- Andrew A. Koleta, 1141 Cordova Ave., Akron, Ohio.
- I. H. Brooks, R. No. 6, Burlington, N. C.
- Paul Yugovich, 311 Penn St., Verona, Pa.
- Edward W. Chamberlin, P. O. Box No. 42, St. Albans, Vermont.
- Nelson E. Loomis, Narrowsburg, N. Y.
- Dr. Walter C. Baker, 1396 Culver Road, Rochester, N. Y.
- Alfred Lampel, 152 S. E. 65th St., Chicago, Ill.
- Sydney R. Elliott, Princeton Radio Service, P. O. Box 213, Princeton, B. C., Canada.
- John G. Frank, Supreme Radio Service, P. O. Box 276, Hudson, Mass.
- C. W. Caldwell, University of South Dakota, Vermillion, S. D.
- Earl Osthoff, Columbus, Kan.
- C. M. Durst, 4907 West Pine, care of Parkside Apts., St. Louis, Mo.
- Alex. Williams, 969 Florence St., Camden, N. J.
- H. N. Bliss, 107 Elmwood Ave., Ithaca, N. Y.
- Everett B. Schwartz, 1436 West Mineral St., Milwaukee, Wis.

Radios Are Restored In New York Taxicabs

Continuance of radios in New York taxicabs was the successful outcome for radio interests of hearings held by police authorities. Despite the opposition of some civic organizations opposing radio in taxicabs, the New York authorities decided to rescind the previous administration's order banning radio from taxis and proceeded to make proper regulations fair to radio as well as traffic and other interests.

SUMMER COURSE REPEATED

The annual radio short course will be repeated this year on March 26th, 27th and 28th under the auspices of the radio department of the University Extension Division, 623 West State Street, Milwaukee, Wis., with lecture sessions each morning, afternoon, and evening.

SUBSCRIBE NOW!

RADIO WORLD, 145 West 45th St., New York City. Enclosed please find my remittance for subscription for RADIO WORLD, one copy each week for specified period.

- \$10.00 for two years, 104 issues.
- \$6 for one year, 52 issues.
- \$3 for six months, 26 issues.
- \$1.50 for three months, 13 issues.
- \$1.00 extra per year for foreign postage.
- This is a renewal of an existing mail subscription (Check off if true)

Your name.....
 Address.....
 City.....

NON-OVERLOADABLE DETECTOR IN A 11-TUBE DUAL-BAL

NEON LAMP, USED AS DISTORTION INDICATOR WAVE FORMS—HIGH-POWERED CIRCUIT IM

By Christoph

IN the construction of a high-powered superheterodyne, say, a 11-tube dual-wave circuit, the weak spot is usually the amplifier following the detector. Let us take as an example a receiver using a 55 tube, as of the duplex-diode types the triode stands the greatest input. The detector, or diode, especially with plates paralleled, is practically non-overloadable, provided there is some automatic volume control. Without such control a strong local might develop 100 rectified volts across the diode load resistor (0.5 meg.), so that through this resistor are flowing 200 microamperes.

There is no way of putting anything like 100 volts into the triode, even if the detector preserves a fairly straight characteristic, so that the trouble is focused on the triode. The limit is something less than the saturation of the triode, saturation meaning here, in effect, that the plate current is cut off. Serious distortion sets in before the cut-off appears complete, although in point of fact the plate current never does cut off, for so long as there is a potential difference across a resistance (here the tube) there is always some current.

An easy way out is to determine that point on the load resistor where operation is satisfactory for a large signal input, and connect the grid of the amplifier to that point. However, that is a direct sacrifice of sensitivity on all signals.

Another way out is to use more automatic volume control, so that the very strong signals will be still more greatly reduced, but in that way it is quite easy to have an over-effective a.v.c., resulting in less than the desired maximum volume for local stations.

Another way is to parallel the triode with another similar triode, as is done in the diagram, where the 55 triode has a 56 in parallel with it, so that the voltage swing permissible in the plate circuit is more than doubled. Besides, the working μ , or amplification or gain in the triode, is reduced, which is desired, since we have started with as much as we can handle, and do not want to build up what is close to an excess already.

The only special precaution is that the load resistance should be high enough so that at no bias at all—absence of signal input—there will not be a ruinous amount of plate current. However, any resistance from 100,000 ohms up will take care of this requirement. Besides, there is never a condition literally amounting to no input, as the local oscillator is functioning, and even though there is nothing much you can hear, there is at least some input to the second detector.

Overload Indicator

Working backwards from the power tube stage, where the negative bias may be around 62 volts, say that the situation permits a signal input of 60 volts and that the transformer has a ratio of 1 to 3, full primary to one-half of secondary. Then the signal voltage permissible in the plate circuit is 60/3, or 20 volts, the working μ

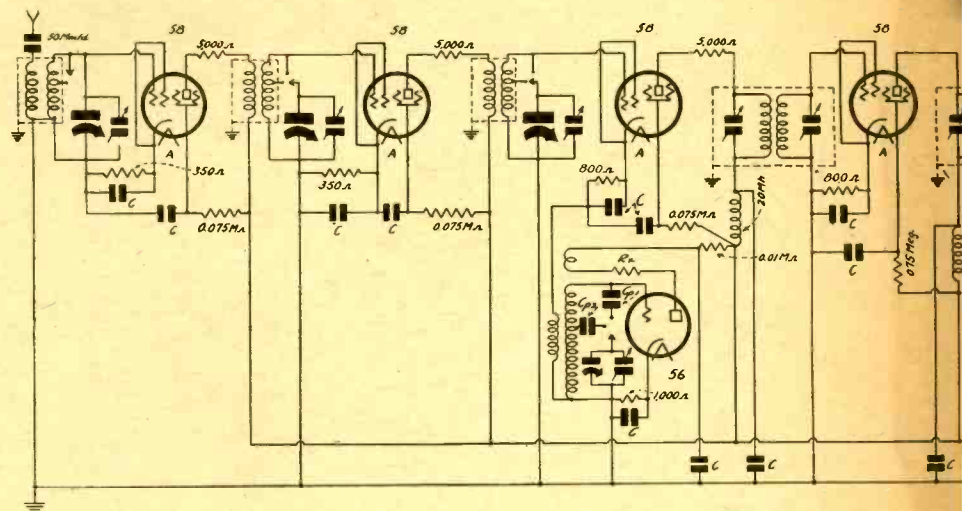

Usually the driver of the output stage is the weakest link in a power amplifier. The triode, with plates paralleled, will stand practically anything likely to be put in, but the driver is not so early. Therefore some a.v.c. is used, just enough for satisfactory

of the triode driver is about 4, and the grid input may be 5 volts before there is even any approach to overloading. With one intermediate-frequency stage subjected to automatic volume control (a sacrifice of sensitivity only on loud signals) there is little likelihood of more than 5 volts from any save the very strongest locals, and then the manual volume control may be used, as that directly regulates the amount of voltage put into the driver.

The power tubes are loaded up, practically, when there are 120 volts total across the extremes of the secondary of the push-pull input transformer. Therefore a small neon lamp of the 120-volt type, with resistor built in, may be used as overload indicator. If the lamp has no resistor in it use 100,000 ohms for the one shown externally at NL. The lamp will strike when the voltage is around 70 or 80 volts, depending on the amount of gas, and will show an orange glow until the wave form becomes bad, when the glow will turn bluish, an indication of overload. Thus if the lamp does not light there is not the faintest trace of overload, if it lights dimly there is plenty of safety margin left, if it glows with accustomed brightness for 120 volts, a degree of illumination one may memorize after viewing the lamp lit from the house line, the limit has been reached, and if that limit is exceeded the bluish glow will be the warning signal, correctible by manual volume control adjustment.

Since the lamp is not always lit it can

not be used for viewing the scale of the receiver's dial.

The Pre-Detector Circuit

It is submitted, therefore, that the method outlined, of using a 56 in parallel with the triode of the 55, takes care of the overload difficulty where it is most serious, and that the paralleled tubes will drive the output stage, and that, besides, there is a visual indicator of overload, plus a manual corrective, so one is fully protected.

The circuit ahead of the second detector requires consideration, particularly as it is directly related to overloading any subsequent tube. Overload of a second detector, driver or output stage depends on what is put into the detector, and the circuit ahead of the detector, in conjunction with the signal, determines that.

A tendency of the radio-frequency amplifier to oscillate is one contributant to overloading, and some stabilization means should be provided. The one selected was the inclusion of series plate resistors, as then also the amplification is nicely evened out, getting rid of the rising characteristic of t-r-f systems. What shall be the value of these resistors depends on the supply voltages, the coupling between primary and secondary, the value of the series antenna condenser, and other factors. If the condenser is as small as 50 mmfd., recommended for city locations, then the resistors must be at least 5,000 ohms, but if the condenser is omitted, as it may be for rural uses, then 5,000 ohms

LISSAJOU'S FIGURES

OBSERVATION OF PATTERNS ON FLUORESCENT SCREEN OF CATHODE-RAY OSCILLOGRAPH TUBE DISCLOSES FREQUENCY RATIOS, AMPLITUDES AND PHASE ANGLES

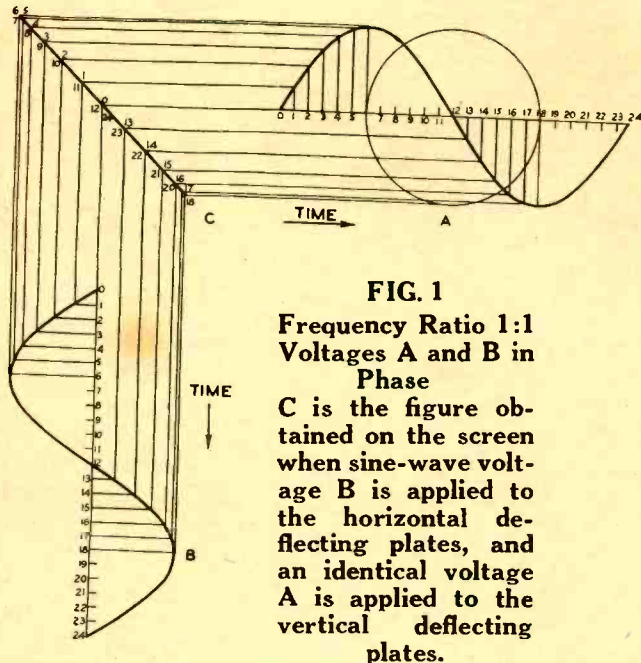

FIG. 1
Frequency Ratio 1:1
Voltages A and B in Phase
C is the figure obtained on the screen when sine-wave voltage B is applied to the horizontal deflecting plates, and an identical voltage A is applied to the vertical deflecting plates.

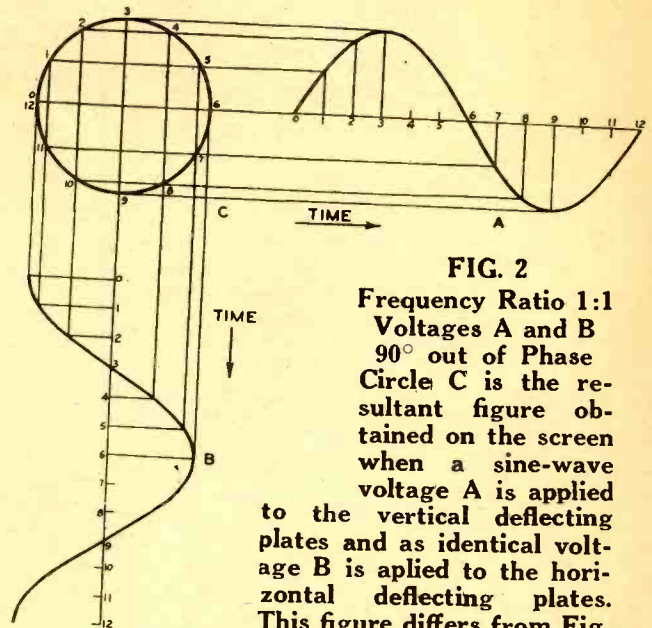

FIG. 2
Frequency Ratio 1:1
Voltages A and B 90° out of Phase
Circle C is the resultant figure obtained on the screen when a sine-wave voltage A is applied to the vertical deflecting plates and as identical voltage B is applied to the horizontal deflecting plates. This figure differs from Fig. 1 only in that the voltage B leads the voltage A by 90°

WHEN varying voltages are applied to the deflecting plates of a cathode-ray tube, a pattern is obtained on the fluorescent screen. The shape of this pattern depends upon the wave forms of the applied voltages and upon their phase relationships. In this Application Note a study of these patterns, or Lissajou's figures, will be made with particular attention to their development, their use in identifying frequency ratios, and the effect of phase shift.

Fig. 1 represents a sine-wave voltage A applied to the vertical pair of deflecting plates of a cathode-ray tube and an identical voltage B applied to the horizontal deflecting plates. The resulting pattern, shown by C is a straight line having a 45-degree slope. The direction of the slope of this line is determined by the phase relation of the two voltages as illustrated in Figs. 6A and 6E.* Fig. 2 illustrates the case of two identical voltages having the same amplitude but 90°, or 270°, out of phase. In this case, the resulting figure is a circle.

Inequality Develops Ellipse

If one of the figures is of greater amplitude than the other, the resulting figure will be an ellipse as shown by Fig. 6C. If the phase relation is such that one voltage leads by 45°, or 315°, the resulting pattern will be that of Fig. 6D; if leading by 135°, or 225°, the resulting pattern will be that of 6B. Figs. 1 to 5 inclusive show a graphical

method for determining the resulting pattern, where the wave shapes, the relative amplitudes, the phase relation, and the frequencies of the two deflecting voltages are known. By means of the cathode-ray tube the resultant pattern is traced on the fluorescent screen. Conversely, from this pattern, the frequency, and the phase relations of the two deflecting voltages can be determined. Where, in addition, the wave form is known for one of the deflecting voltages, the wave form of the other can readily be obtained by graphical analysis.

Figs. 1, 2, and 6A to 6E are for a 1:1 frequency ratio. When a 2:1 ratio of the voltages applied to the deflecting plates is the case, the wave shapes of Figs. 6A to 6E become those shown by Figs. 6F to 6J.

Complex Figures

As the ratio of the frequencies increases, the pattern becomes more complex. In Fig. 3, A and B are the voltages applied to the deflecting plates. In this case the frequency of A is three times that of B. The resultant figure C shows a 1:3 pattern in which both voltages start in phase. Fig. 4 is the same as Fig. 3 except that voltage A is started 90° out of phase with respect to voltage B. Figure 5C shows the resultant pattern obtained where B is a saw-tooth wave and A a sine wave. This is of interest because this type of wave form results when a linear timing axis is used. Figs. 7, 8, and 9 show patterns of increasing complexity, Fig. 9 being an 8:6 pattern.

When the cathode-ray oscillograph is used for calibration purposes, frequency ratios of less than 10 : 1 can be readily determined by visual inspection of the image. For frequency ratios greater than 10 : 1, the complexity of the pattern makes visual deter-

mination difficult and requires determination by means of photography. In general, the standard frequency selected should be one the multiples and submultiples of which will cover the desired range and provide the simplest patterns.

In examining Lissajou's figures, one should consider them as the side view or elevation of a picture traced on a glass cylinder on which the observer may view the wave as it travels around the cylinder. The illusion is clearest when the whole figure rotates slowly.

Simplifying the Determination

Fig. 10 is a simple single-line pattern having a frequency ratio of 6 : 1. With a base frequency of 60 cycles this pattern would be the picture for 360 cycles, or with a base frequency of 100 cycles, would be the picture of 600 cycles. The frequency ratio is determined by counting the peaks (six in number) of the waves in the horizontal plane and the number of end loops which for this case is one; hence, a frequency ratio of 6 : 1. In Fig. 10, the front tracing has been made heavy and the back tracing light so that the two can be readily distinguished. If the figure were to be shifted slightly, the front and back waves might appear to be one. This condition might mislead the observer to believe that the frequency ratio was less than 6 : 1. Adjustment of the unknown frequency so that the pattern rotates very slowly, or stands still with the rear peaks uncovered by the front peaks, will make determination simplest. It will be observed that the wave form of Fig. 10 corresponds to that of Fig. 13*, a single-line pattern whose back trace is not visible. Figure 19 shows the simplest 2 : 1 wave or two-line figure. Figure 11 is a complete two-line figure illustrating a ratio of 9 : 2, which

*Figs. 6 to 12 inclusive, and Figs. 22 and 23 adapted from "Frequency Measurements with the Cathode Ray Oscillograph," Frederick J. Rasmussen, A. I. E. E. Transactions, November, 1926, Vol. XLV, Pages 1256-65.

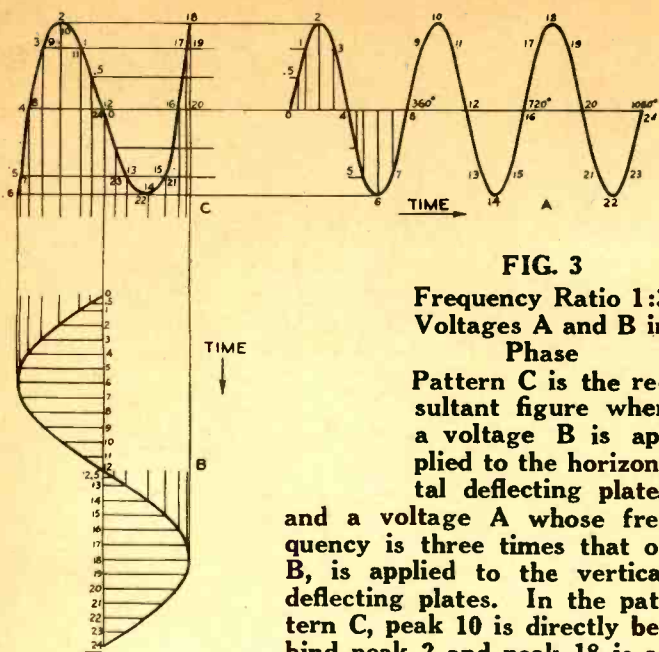

FIG. 3
Frequency Ratio 1:3
Voltages A and B in Phase

Pattern C is the resultant figure when a voltage B is applied to the horizontal deflecting plates and a voltage A whose frequency is three times that of B, is applied to the vertical deflecting plates. In the pattern C, peak 10 is directly behind peak 2 and peak 18 is at the right.

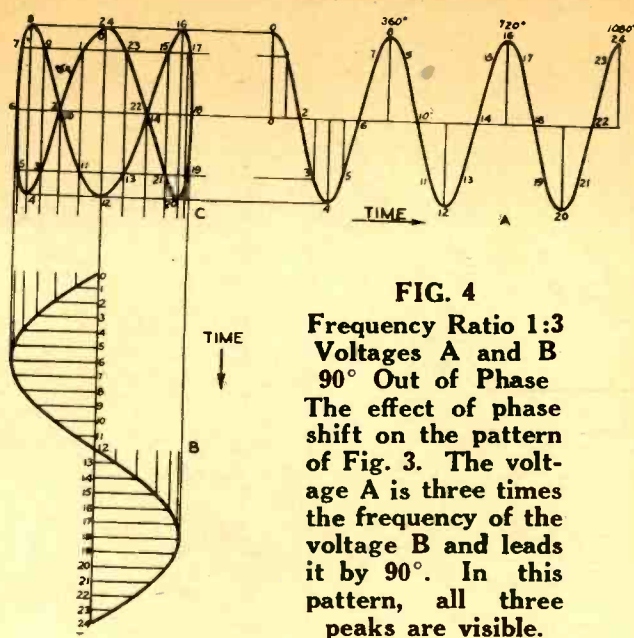

FIG. 4
Frequency Ratio 1:3
Voltages A and B 90° Out of Phase

The effect of phase shift on the pattern of Fig. 3. The voltage A is three times the frequency of the voltage B and leads it by 90°. In this pattern, all three peaks are visible.

again, is readily determined by counting the number of peaks along the top of the figure and the number of loops at the end. Figure 12 has 16 peaks and is a three-line pattern, indicating a frequency ratio of 16:3.

Figs. 10, 11, and 12 illustrate patterns as they generally appear on the fluorescent screen. Figs. 7 to 9 and 13 to 19 are shown as pictures of an appearance suggesting that the pattern has been developed on a plane. They have been shown in this fashion to facilitate study.

An optional method for determination of the frequency ratio is that of comparing the number of peaks on a given figure with the horizontal lines of intersection on the figure instead of with the number of loops at the end of the figure. A study of some of the patterns will make this clear. In Fig. 16 there is a single line of intersections along the axes of the figures.

Sequence of Patterns

It can easily be seen that this is a two-line figure by comparing it with the single-line Figs. 13 and 19. Figs. 12, 15 and 17 have two horizontal lines of intersections each spaced approximately one-third from the top and bottom are three-line patterns. In the same manner, the four-line patterns of Figs. 7, 14, and 18 are distinguished by three lines of intersection, the five-line pattern of Fig. 8 by four lines of intersection, and the six-line pattern of Fig. 9 by five lines of intersection with characteristic positions for these lines in each case. Thus, the frequency ratio is also equal to the number of peaks on circumference divided by the term (1 + number of horizontal lines of intersection).

Of the patterns from 1 to 19, those of Figs. 13, 19, and 3 show simple ratios of 1 : 1, 2 : 1, and 3 : 1. Both these direct multiples and fractional multiples of the base frequency are available to the user of the cathode-ray oscillograph.

Tabulation of Sequence

For example, with a base frequency of 60 cycles, the following tabulation will serve to illustrate the sequence of relatively simple patterns obtained as the frequency of the variable unit is decreased from a 1 : 1 ratio of frequencies to a 3 : 1 ratio.

Frequency In Cycles/Sec.	Frequency Ratio*		Illustrated By Fig.
	Whole No.	Fractional	
60	1 : 1	1 : 1	13
75	5 : 4	1 1/4 : 1	14
80	4 : 3	1-1/3 : 1	15
90	3 : 2	1 1/2 : 1	16
100	5 : 3	1-2/3 : 1	17
105	7 : 4	1 3/4 : 1	18
120	2 : 1	2 : 1	19
135	9 : 4	2 1/4 : 1	..
140	7 : 3	2-1/3 : 1	..
150	5 : 2	2 1/2 : 1	..
160	8 : 3	2-2/3 : 1	..
165	11 : 4	2 3/4 : 1	..
180	3 : 1	3 : 1	3

*The frequency ratio is expressed either as a ratio of two integers, the first of which represents the number of peaks and the second the number of lines in the patterns, or as a ratio of a whole number and a fraction to unity. The denominator of the fraction is equal to the number of lines in the figure.

If the base frequency is 1,000 cycles instead of 60, the same ratios hold. Thus, instead

of 60 to 180 cycles, the frequencies for these patterns would be those for 1,000 to 3,000 cycles with intermediate values of 1,250, 1,333-1/3, 1,500, 1,666-2/3, 1,750 cycles, 2,000 cycles, 2,250 cycles, 2,333-1/3 cycles, 2,500 cycles, 2,666-2/3 cycles, and 2,750 cycles.

Elliptical and Circular Figures

When waves having frequency ratios greater than 10 : 1 are compared, accurate determinations may be difficult with the front and back portions of the figures in the same horizontal plane. To separate the back and front portions, the figures can be displaced to show either on an ellipse or a circle.

For an ellipse, a phase-splitting device consisting of a resistance and a capacity is employed. See Fig. 24. Resistance R is connected across one set of deflecting plates and capacitance C is connected across the other pair. Figs. 20 and 21 show the same single-line pattern and were obtained by adjusting the circuit of Fig. 24 for different vertical amplitudes. Fig. 22 is a two-line pattern having a frequency ratio of 31 : 2. The frequency ratio of this figure would be much more difficult to determine without displacement.

To produce the type of pattern shown in Fig. 23 a circular axis is developed using the circuit of Fig. 24, with the exception that (Continued on next page)

FIG. 5
Frequency Ratio 1:2
Voltages A and B in Phase

A sine-wave voltage A applied to the vertical deflecting plates and a saw-tooth wave B applied to the horizontal deflecting plates. Wave B is linear from 0 to 14; hence, on the pattern C, the sine wave A appears undistorted. During the interval 14 to 16, the trace returns to the starting point 16.

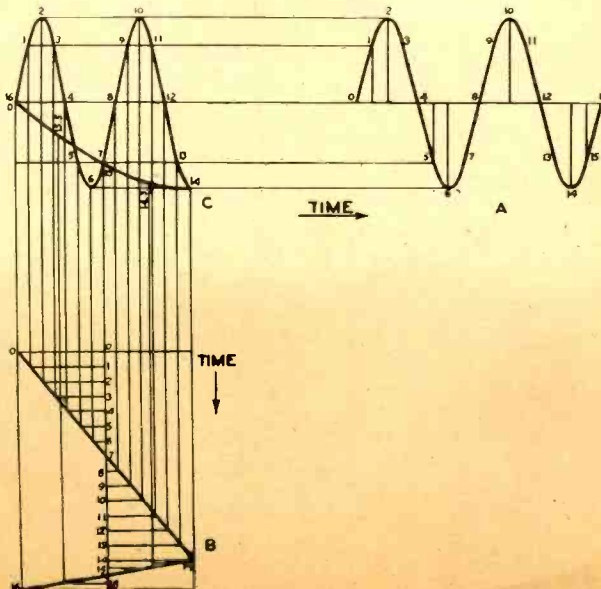

*Figs. 13 to 19 inclusive, and Figs. 20 and 21 adapted from "The Cathode Ray Oscillograph in Radio Research," R. A. Watson Watt. Published by His Majesty's Stationery Office, London, England.

FIG. 6

The relationship of the phases of unequal voltages results in figures as shown. When the voltage ratio is 2 to 1 the bottom figures apply. The phase relations are common to the two tiers.

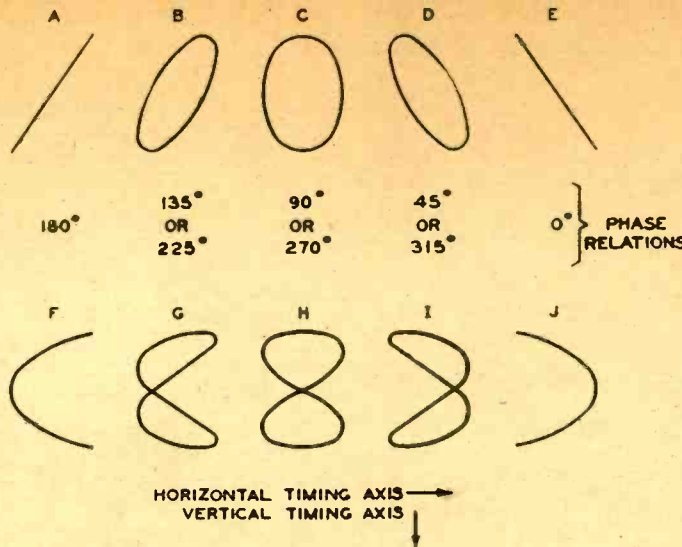

PHASE-SPLITTING CIRCUIT FOR OBTAINING ELLIPTICAL OR CIRCULAR AXIS

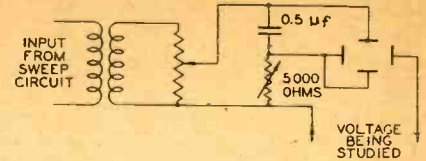

FIG. 24

This shows a method of splitting the phase between the two deflecting voltages applied to a cathode ray oscilloscope for obtaining frequency ratios. The object of phase-splitting is to separate the go and return traces on the screen.

Figs. 7 to 9 and 13 to 19 are developed on a plane. The resulting patterns are much simpler than they would be with their normal appearance because the back wave has been removed by spreading it out in the same plane with the front wave. The advantages of this simplified appearance can be obtained in practice by total elimination of the back wave.

Where there is some doubt as to the number of lines in a pattern because of the presence of the additional lines of intersections observed in the back wave, this method will be of considerable assistance. Fig. 11, for instance, is a two-line pattern, as is shown by the two loops at the end of the figure. However, because of the shift of the figure, the intersection made by the lines of the back wave with the lines of the front wave give it the same appearance as the five-line pattern of Fig. 8. To eliminate the back wave, voltage of the same frequency as that used for the spreader, but 90° out of phase, is applied to the control grid of the cathode-ray tube. Adjustment of this voltage will permit weakening the back wave and brightening the front wave, or the total elimination of the back wave.

Copyright 1934 by RCA Radiotron Co.

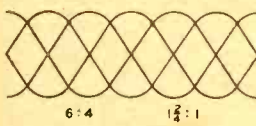

FIG. 7



FIG. 13

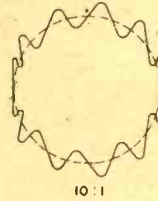

FIG. 20

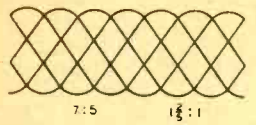

FIG. 8

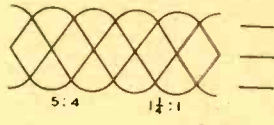

FIG. 14

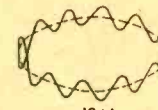

FIG. 21

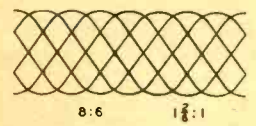

FIG. 9

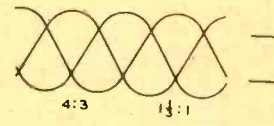

FIG. 15

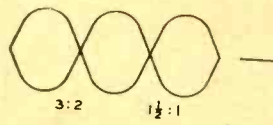

FIG. 16

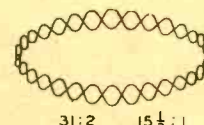

FIG. 22

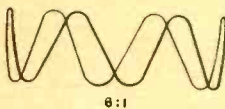

FIG. 10

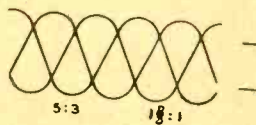

FIG. 17

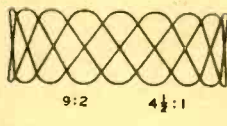

FIG. 11

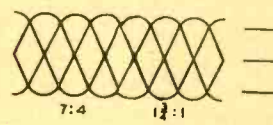

FIG. 18



FIG. 23

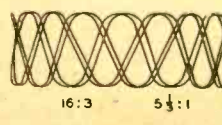

FIG. 12

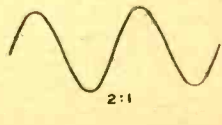

FIG. 19

Figs. 7 to 23 inclusive are patterns that disclose the frequency relationships of two a-c voltages as read on the fluorescent screen of a cathode-ray oscillograph tube. Ratios of less than 10 to 1 may be thus determined by visual inspection. In higher ratios photography is advisable. The patterns are above the figure numbers.

(Continued from preceding page)

the voltage under study is introduced in series with anode No. 2. It will be found that the peaks on this type of pattern will be somewhat blurred due to the defocusing ef-

fect caused by introduction of the voltage under study into the anode No. 2 circuit. Defocusing can be minimized by keeping this voltage at a low amplitude.

It was pointed out that the patterns of

Brinckley Faces Ouster from Mexican Wave

Mexico City, Mexico.

Dr. J. R. Brinckley, ruled off the air in the United States for a type of medicine advertising, and operating for a year in Mexico, has had his Mexican station license suspended and faces its total revocation. He was known as the "goat-gland doctor of Milford, Kansas."

Four Brooklyn Stations Face Loss of License

Washington.

An examiner has recommended to the Federal Radio Commission the recall of the licenses held by WARD, WBBC, WLTH and WVFV, Brooklyn, N. Y. They now share time. There are other applications for the wave, not acted on yet.

A THOUGHT FOR THE WEEK

GERMANY and Italy figure largely in the news of radio. Germany has completed purchase of 5,000,000 low-priced radio sets, which its people started buying three years ago, and this means that at least one family out of three in Hitlerland owns a set. Italy has installed sets in schools throughout the land, and now classes in even remote villages can listen in and learn something of educational value from the headquarters of the Director General of Elementary Schools in Rome.

Though this country has made remarkable strides in radio, we must not be smiling and smug in the belief that Uncle Sam is the only national radio figure and that the rest of the world is sitting still and waiting for the other fellow to show it how.

At left, a strictly diode-biased triode, where the bias depends on the rectification of the signal, but only so much rectified voltage is taken off as desired (volume control).

At right is a pentode used as diode to feed a principally diode-biased amplifier that also has some self-bias or delay voltage.

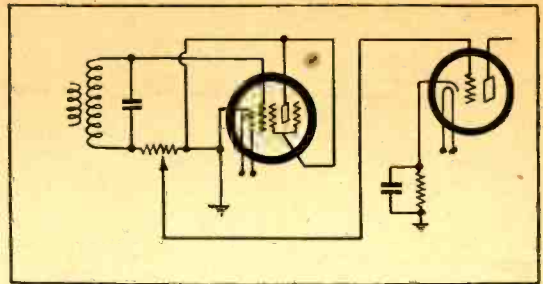
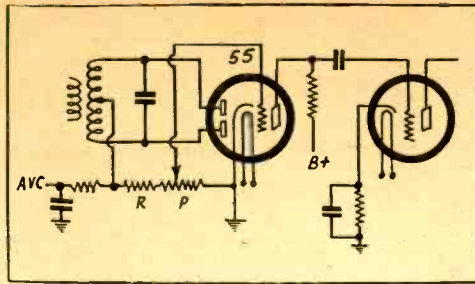

Radio University

A QUESTION and Answer Department. Only questions from Radio University members are answered. Such membership is obtained by sending subscription order direct to RADIO WORLD for one year (52 issues) at \$6 without any other premium.

RADIO WORLD, 145 WEST 45th STREET, NEW YORK, N. Y.

About High-Gain Couplers

IN radio frequency couplers of the so-called high-gain type there is a single turn of wire around the high potential end of the tuned winding, one end of this wire being connected to the plate and the other left open. How can such a device work when it is open at one end? Certainly no current can flow through it. Will you kindly explain the operation of the device?—W. R. L.

The single, open-end turn is one side of a small condenser. The other side is the wire in the tuned coil. There is sufficient capacity between the two to couple satisfactorily the plate of the tube to the tuned circuit. If a circuit of this type is to work right, it is necessary that there be a high impedance between the plate and the cathode. That is the reason there is always a choke coil in one of these couplers. The inductance of this choke is selected so that it resonates with the tube output capacity at the lower frequency end of the tuning scale, thus building up the amplification at that end. The device is not only effective but it levels out the amplification. See the diagram at top of next page.

* * *

Utilizing Screen for Control

SUPPOSE the grid voltage of a 34 be held constant at a given value and an alternating voltage is superposed on the screen voltage, the plate voltage being held constant, is there a variation in the plate current? If so, what does it amount to and in which direction is the variation?—L. J. H.

If the grid bias is held at 1.5 volts, negative, and if the plate voltage is 250 volts, the variation in the plate current amounts to the same as if the amplification factor were 7.5, and the plate current varies in the same direction as the screen voltage. In other words, we can use the arrangement for amplification provided the circuit is such that a large screen current does not matter.

* * *

Padding Trouble

ABOUT one year ago you published curve and formulas for padding superheterodynes. They appeared to be all right, but I have made application of them and I cannot get as close tracking as the formulas indicate. I have faith in the formulas, for I have gone over them carefully and cannot find any errors. Still I have more faith in my experiments. Can you reconcile the two?—W. R. H.

The formulas were based on ideal circuits, such as are approximated when the tuned circuit is used as a wave trap with very

loose coupling between the source of power and the trap. When a coil and condenser are connected to a vacuum tube, other factors enter. This is the case especially in the oscillator, the frequency of which is affected by plate and grid resistances, chokes, by-pass condensers, and other elements of the practical circuit. Naturally, these will change the tuning characteristics of the oscillator. Hence we cannot expect close agreement between theory and practice. But we can expect a great improvement if the padding is done correctly. The extent of the variation can be estimated from the probable frequency deviation of the oscillator. It is not unusual to have the frequency of the oscillator differ by one per cent. from the natural frequency of the tuned circuit. At 1,500 kc this deviation amounts to 15 kc and at 550 kc it amounts to 5.5 kc. Even the lower value amounts to much more than the maximum deviation that can be expected from correct padding.

* * *

Beat Oscillator Calibration

IS it possible to calibrate a beat frequency oscillator so accurately that the output may be used as a standard of sound frequencies, say to an accuracy of one per cent. or better? If not, is it practical to have a standard built in by which the beat could be checked now and then?—W. R. J.

That is possible by having two highly stabilized radio frequency oscillators beating together, provided that the dial used for tuning is large and that it is coupled to the condensers without lost motion. The limitation on the calibration is mechanical rather than electrical, assuming that the oscillators are stabilized. If the frequency drifts a little, it can always be checked at some fixed frequency, say a 60-cycle line frequency, or better still, a tuning fork. The point on the dial where this standard should come in could be marked clearly, the oscillator dial set at that point, and then the beat frequency could be made to coincide with the standard tone by adjusting a minute capacity in one of the radio frequency oscillators.

* * *

Gas Amplification Factor

IN a recent issue you published data on a phototube in which you mention, and define, gas amplification factor. Will you kindly explain how it is possible for gas to cause an increase in the current in the phototube? If there is gas amplification in a phototube, is there also gas amplification in a thermionic tube?—R. L. W.

The gas amplification is due to ionization

by collision of electrons with molecules of the gas. Suppose there is a certain voltage between the anode and the cathode. This voltage will give the electrons a certain velocity. If an electron has a chance to move far enough without colliding with a gas molecule, it will release other electrons when it does strike. As soon as these are released, they will start for the anode and they too might get up speed enough to release other electrons. The effect is cumulative. At a certain voltage the anode current becomes practically infinite, and the tube becomes luminous. The ionization occurs in every electron device but when it occurs depends on the voltage and the amount of gas. If the gas pressure is too high, there can be no ionization, for a given voltage, because no electron has a chance to move far enough to cause ionization on collision. If the gas pressure is too low, there will be no appreciable ionization because there are too few molecules with which the electrons can collide. For this reason high vacuum phototubes and thermionic tubes do not show any ionization effects.

* * *

Set Works Without Ground

WHY is it that some short wave sets work better without a ground connection than with one? It has always been a rule in radio that the best possible ground should be used for best results, and now best results are obtained without any ground at all.—G. W. B.

The rule still holds good. The best possible ground should be used for best results. But the ground that is best for broadcast waves may not necessarily be the same as the best ground for short waves. You may think that your short wave set has no ground, but it has all right. There is plenty of capacity between your set and ground through which the short waves can get to ground. The reason why this arrangement gives better results may be that this particular capacity is required to tune the primary circuit to the signal wave, or it may be that with this capacity in series with the ground circuit the antenna series capacity is better able to cover the range. When it comes to short wave circuits it is almost impossible to say that this is this or that. A coil may be a condenser, a condenser may be an inductance, a resistor may be either an inductance or a condenser, and what looks like an open circuit may in fact be a short circuit. It is difficult to confine short wave currents to any particular circuit, and that may be one reason why they come from the other side of the world.

* * *

Diode-Biased Triodes

WHAT IS THE DIFFERENCE between the 55 as a diode-biased triode and a regular triode, etc., used as diode to bias an amplifier the same way?—I. R. W.

There is no difference, save that the two tubes are in one envelope in the instance of the 55, and each tube is in a separate envelope in the case of the triode, quorode or pentode used as diode. At left above is a diode-biased 55, with volume control a 500,000-ohm potentiometer P, R being a limiting resistor selected so that the signal never causes the amplifier of the 55 to saturate.

(Continued on next page)

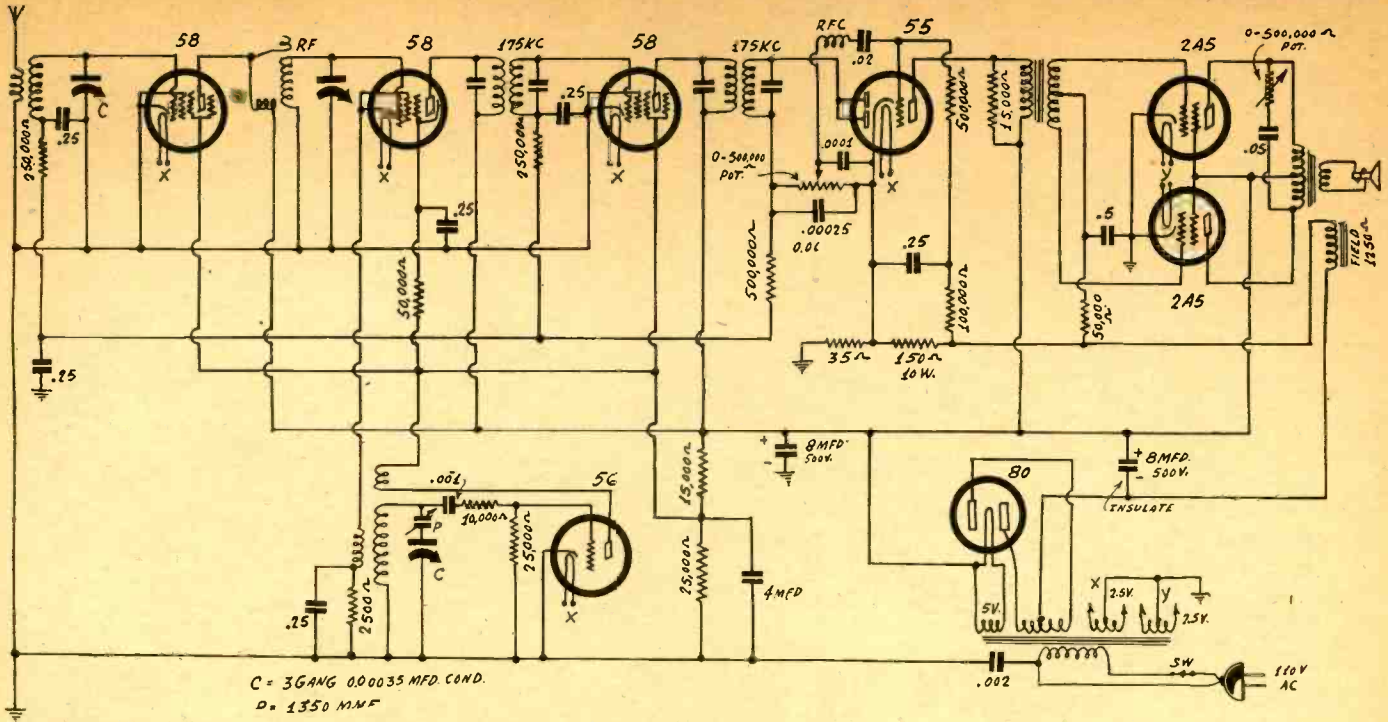

(Continued from preceding page)

The pentode used as diode, at right, operates on exactly the same principle, but a little delay voltage is introduced in the amplifier, as can be seen from the fact the triode is self-biased, whereas in the 55 the triode is entirely diode-biased.

A Universal Super

WILL you kindly publish the circuit diagram of a d-c operated superheterodyne having eight or nine tubes? I would prefer using tubes with high heater voltage so that not so much power is wasted in the ballast resistors.—W.H.V.

In the figure below is a diagram of an eight-tube superheterodyne of the universal type. It will work on 110 volt lines of either a.c. or d.c. The 25Z5 is used as a rectifier for the field current of the loudspeaker and of the plate supply. When the circuit is used on d-c lines this tube functions primarily as a protection. It does not interfere with operation in any way even when it is not essential. The rectifier tube is particularly useful in this circuit in view of the fact that it has two separate rectifier elements. The oscillator in the circuit is of the tuned grid type with negative bias.

The second coil from left at top has a few turns as coupling condenser.

Perhaps somewhat better results would be obtained if a grid stopping condenser and a grid leak were used, which could be in addition to the grid bias. The usual values of 0.00025 mfd. and 100,000 ohms would be all right, although a lower grid leak resistance would work fine too.

Amplitude and Frequency Stability

WHY is it that if an oscillator has frequency stability it is also amplitude stable, and vice versa? In other words, why are these two so intimately associated?—W. H. A.

The vice versa part of the above question is all right but not the other. An oscillator may be frequency stable without having amplitude stability. This occurs when the tube looks into pure resistances either way at the frequency of oscillation. When an oscillator is such that it has amplitude stability, it is frequency stable because the factors on which the frequency variation de-

pends are held constant. That is, if the plate and grid resistances are held constant, thereby holding the amplitude constant, the frequency does not change.

Why Miniature Tubes

WHAT is the purpose of the new small tubes? That is, why is it necessary to design special small tubes for short waves just because the waves are short? Certainly these tubes will not handle as much power as the larger tubes.—W. N. C.

It is a question of getting down to the short waves. The frequency that can be generated by any circuit is limited by the inter-electrode capacities of the tubes. In order to reach the short waves of the order of a meter or so it is essential to make the capacities as small as possible. This is also necessary in order to get any power at all on the frequencies generated, or any efficiency in case the tube is used for reception. Capacities can be small only by making the elements of the tube small or by placing them far apart. But placing them far apart increases the dimensions and that in turn increases the inductance of the leads, which is not desirable either. Hence it is essential primarily to decrease the size of the tubes.

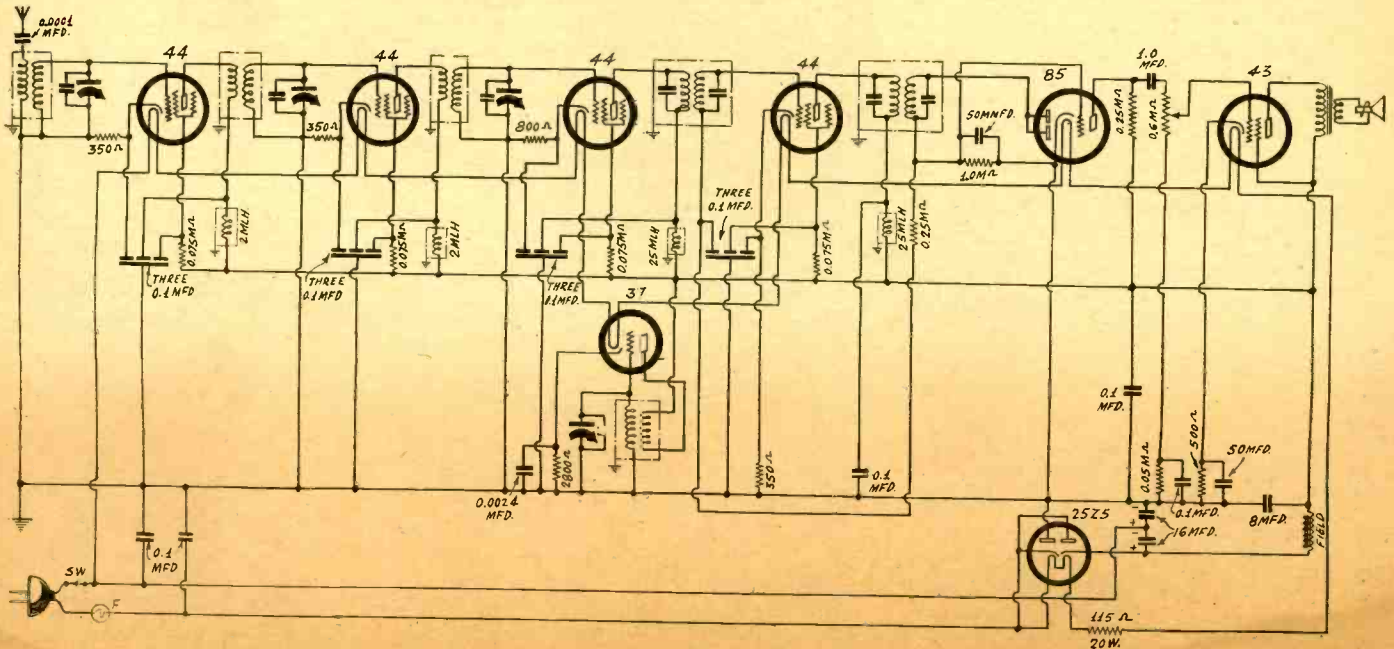

The circuit of an eight-tube universal superheterodyne which works equally well on a.c. and d.c.

No, they do not deliver as much power as the larger tube, but that is of no consequence when a tube is to be used in a receiver. The power involved in the high frequency level is so minute that it is not necessary to provide much power handling capability. Using a large tube would be about as sensible as employing an ocean liner for towing a row-boat.

Shortest Waves

HOW long are the shortest waves that have been generated by radio tubes? Have they succeeded in going much below one meter? What type of circuits are used in the generators, and what kind of tubes?—W. R. W.

They have succeeded in getting down to a few centimeters. Most of the oscillators employed for getting down really low are of the magnetron type. These tubes differ from ordinary tubes in that the electron stream is controlled by means of a magnetic field in place of an electrostatic field. Usually the tube consists of two semi-cylindrical plates facing each other and practically surrounding the cathode. In some tubes the magnetic field is parallel to the cathode and to the axis of the cylindrical plates. In others the magnetic field is inclined 45 degrees. The parallel type is called magnetron and the 45-degree type is called magnetostatic tubes.

Natural Frequency of R-F Choke

ABOUT how high is the natural frequency of a radio frequency choke coil, say one of 10 millihenries. Is it a fact that above the natural frequency the impedance of the choke is very low that it virtually amounts to a short circuit?—W. H. C.

The natural frequency of a choke depends on the inductance and on the self capacity. A well-constructed choke of 10 millihenries might have a self capacity of one micro-microfarad. This would make the natural frequencies 1.59 megacycles. The impedance of the choke does not immediately become low after the frequency has exceeded the natural frequency. It has to become considerably higher even before the impedance is less than it would be for a pure inductance, which is due to the fact that at the natural frequency the impedance is exceedingly large. At much higher frequencies the coil acts as a condenser of capacity equal to the self capacity. If that capacity is 1 mmfd., the reactance at 10 million cycles would be 1,600 ohms. The natural frequency of a choke is one thing and that of the choke in a given setting is something entirely different. Suppose, for example, that the coil mentioned above is connected in the plate circuit of a pentode having an output capacity of 6.8 mmfd., which is the value for the 58 pentode. The total capacity of the circuit is then at least 7.8 mmfd. Let us say that it is 8 mmfd. The natural frequency of this circuit is 566 kc. Thus it falls at the lower end of the broadcast band. That is the reason the 10 millihenry choke is used in high-gain couplers, where resonance is desirable at frequencies near, or just below, the lower broadcast limit. At the upper limit a capacity of 8 mmfd. makes the impedance rather low, but it would be nearly as low if the coil were not used.

Direction Finders

PLEASE show simple arrangements for hooking up direction finders. I wish to experiment a little with them on a boat. I am interested in balanced circuit by means of which the uncertainty of direction is eliminated.—C.W.L.

You will find two different hook-ups on this page. The first, on the left, depends on the use of a symmetrical tube, one having two equal grids and two equal plates. If this is used in a push-pull arrangement as shown complete balance can be effected. However, tubes of that type are not easily obtainable. A more practical arrangement is shown at the right in which an ordinary

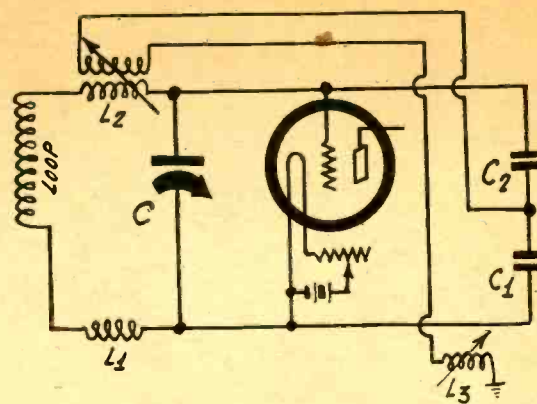
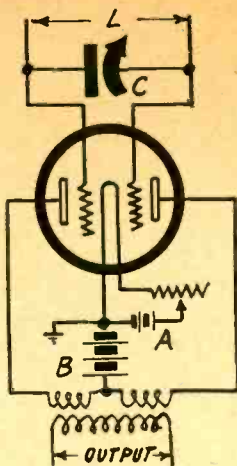

Two arrangements used in direction finders. The circuit on the right, when properly adjusted, yields the cardioid reception pattern. There is only one direction from which no signals are received.

triode is used. Balance is effected by means of C1 and C2. The vario-coupler L2 is a device for determining the sense. L1 and L2 should be equal.

Meaning of Negative Resistance

A DYNATRON is supposed to have negative resistance in the plate circuit. How is it possible for a resistance to be negative?—G.K.L.

By negative resistance is meant that the plate current increases as the plate voltage is decreased, and vice-versa. When such a state of affairs obtains, it means that power is delivered to the plate circuit from some source. Obviously, in the dynatron, it is the screen that supplies the power. The

screen potential attracts the electrons from the cathode and give them a high velocity. Some of these do not hit the screen but go on to the plate. When they strike the plate other electrons are released from that, and they are attracted back to the screen. When an electron falls through a given potential, such as that which exists between the screen and the cathode, it acquires a certain kinetic energy. It is this that carries the electron to the plate against the electrical forces and it is the kinetic energy that is left when the electron has reached the plate that causes the release of other electrons. It is in this manner, that is, falling of an electron through a high potential, that power is delivered to the plate circuit. Hence the negative resistance.

SOME BRAND-NEW OFFERS

Two Almost for the price of One

Radio World is \$6.00 a year (52 issues). Read the following Combination Offers for Radio World and other worth-while publications for one full year on each offer.

- RADIO WORLD and POPULAR SCIENCE MONTHLY \$6.50.
- RADIO WORLD and RADIO-CRAFT (monthly, 12 issues) \$6.50.
- RADIO WORLD and RADIO INDEX (monthly, 10 issues), stations, programs, etc., \$6.35.
- RADIO WORLD and RADIO (monthly, 12 issues; Short Wave and Experimental) \$6.60.
- RADIO WORLD and EVERYDAY SCIENCE AND MECHANICS (monthly) \$6.50.
- RADIO WORLD and RADIO LOG AND LORE. Bi-monthly; 5 issues. Full station lists, cross indexed, etc., \$6.25.
- RADIO WORLD and AMERICAN BOY — YOUTH'S COMPANION (monthly, 12 issues; popular magazine) \$6.50.
- RADIO WORLD and BOYS' LIFE (monthly, 12 issues) \$6.50.
- RADIO WORLD and MOTION PICTURE MAGAZINE (monthly) \$6.50.
- RADIO WORLD and MOVIE CLASSIC (monthly) \$6.25.
- RADIO WORLD and SCREENLAND (monthly) \$6.50.
- RADIO WORLD and SILVER SCREEN (monthly) \$6.25.
- RADIO WORLD and THE PATHFINDER (weekly) \$6.25.
- RADIO WORLD and TRUE STORY (monthly) \$6.50.
- RADIO WORLD and LIBERTY (weekly) \$6.50.

Select any one of these magazines and get it for an entire year by sending in a year's subscription for RADIO WORLD at the regular price, \$6.00 plus a small additional amount, per quotations above. Put a cross in the square next to the magazine of your choice, in the above list, fill out the coupon below, and mail the quoted price by check, money order or stamps to RADIO WORLD, 145 West 45th Street, New York, N. Y. (Add \$1.50 for extra foreign or Canadian postage for both publications.)

Your Name..... **DOUBLE**

Your Street Address..... **VALUE!**

City..... State.....

- If renewing an existing or expiring subscription for RADIO WORLD, please put a cross in square at beginning of this sentence.
- If renewing an existing or expiring subscription for other magazines, please put a cross in square at the beginning of this sentence.

RADIO WORLD, 145 West 45th Street, New York. (Just East of Broadway)

The Review

Questions and Answers Based on Articles Printed in Last Week's Issue

Questions

1. Why is a tuned-radio-frequency receiver preferable to a superheterodyne for calibrating test oscillators?
2. Is it possible to calibrate test oscillators that generate lower frequencies than the receiver responds to, if so why? Is it possible to calibrate test oscillators that generate higher fundamentals than the fundamentals of the receiver? Why?
3. What is the effect of an unbypassed series resistor in the plate circuit (in series with the primary), in respect to sensitivity in a t-r-f tuning range? State approximately the value of a suitable resistor for broadcast frequencies.
4. What is a good reason for putting the volume control in the audio level in a receiver to be used for calibration of a test oscillator?
5. State under what conditions a neon lamp may be used as an overload indicator.
6. State the difference between Class A, Class B, Class AB and Class C audio.
7. When a power tube is supposed to have 300 volts on the plate, with a negative bias of 50 volts, and both voltages are taken from the same total, what is the applied plate voltage? Between what points should applied plate voltage be measured? What danger of error lurks in plate voltage measurements to ground?
8. What is meant by the bare assertion that a choke intended for B-supply filtration has an inductance of 30 henries? Does current affect the inductance?
9. Why should the d-c resistance of a B choke be low if a mercury-vapor rectifier tube is used, and should the inductance be low, too, or high, and explain why?
10. What is a noise-producing possibility in the use of a mercury-vapor rectifier, and what are two simple solutions of the trouble?
11. What result obtains when a test oscillator, generating a low frequency, is left at one frequency, and a receiver operating at higher frequencies is turned, so that two responses are heard at two places on the receiver, and more responses as the receiver is tuned to frequencies farther removed? What result obtains when the test oscillator is variably tuned and the receiver left at one position, the receiver yielding several or numerous responses?
12. Why does reduction of the capacity of a series antenna condenser in a short-wave receiver make the regeneration keener, or bring about its presence whereas otherwise regeneration might be absent?
13. Does a stage of audio enable one to hear stations on an earphone receiver that one could not hear when the earphones are in the detector circuit?
14. State what constitutes a dynatron oscillator, and whether dynatrons are inherently stable or unstable as to frequency, and whether, if unstable, they may be stabilized.
15. In short-wave supers, is more gain obtained usually from the r-f tuner or from the intermediate amplifier, and why?
16. When a resistance meter is being constructed and it is desired to have the zero-resistance setting adjustable, to atone for differences of voltage due to battery, should a rheostat be used in conjunction with the theoretical value of fixed resistance for the limiting purpose, or should this fixed resistance be larger than the theoretical value, and why? What is the sense of so constructing the series combination that the total resistance may be greater than the sensitivity of the meter seems to require?

17. What are the small bulging tips called that may be compressed for a tight fit into a pup jack? These devices, aside from the flexibility and shape, are like phone tips.

18. Is a receiver that is most efficient also most sensitive? Explain the difference.

19. What is a method of compensating for the change of inductance due to meteorological effects upon the coil itself, not to mention the form?

20. When a receiver brings in a station at one point, and in dialling there is a silent point just a bit removed, a bit farther over in the same direction the same station is heard again, of what is this a sign? The question does not refer to repeat points due to the superheterodyne phenomenon.

Answers

1. A tuned-radio-frequency receiver is preferable because all the tuning is at one level, hence there is no confusion due to multiplicity of responses, that is, uncertainty as to which is the response frequency to be used for the calibration.

2. Since the test oscillator generates harmonics, it may be calibrated in conjunction with responses from a receiver that covers higher frequencies, provided these frequencies are high enough to be at least to the second harmonics of the test oscillator's fundamentals. If the test oscillator generates higher frequencies than those to which the receiver responds, a station frequency of one-half, one-third, etc., of the desired value may be put into the receiver and the test oscillator may be beaten with the second, third, etc., harmonic in the receiver's detector. This assumes a non-linear detector, and in general rules out diodes.

3. A series plate resistor has the effect of leveling the amplification in a variably-tuned system, due to the resistor being of a greater deterrent at the high frequencies, where t-r-f amplification is otherwise highest, and of small effect at the lower frequencies, provided the resistance value is suitably chosen, e.g., 2,000 ohms up, for the broadcast band.

4. The volume control, if in the r-f amplifier or detector, has a detuning effect, which might offer serious difficulties if a receiver is frequency-calibrated and used as a standard of measurements.

5. Since the neon tube will strike at a certain voltage, the tube may be so connected that when the signal put into a biased tube circuit is greater than the negative bias on that tube, the neon lamp will glow.

6. Class A audio amplification is the familiar kind, where the recommended plate and bias voltages for standard purposes are applied, and the operating point is therefore about midway on the plate current, grid voltage curve. Class B amplification is one of high negative bias, or in some systems, of zero bias, so that the grid is swung only in a positive direction, thus enabling greater power output and higher efficiency. Class C audio does not exist in practice. Class AB is in between A and B, e.g., a tube that for Class A would take 300 volts for plate and 50 volts for negative bias, might be given 350 plate volts and 65 negative B volts.

7. The applied plate voltage is the difference between the negative bias voltage and the total voltage, or 250 volts, for such a case. The applied voltage is measured between cathode and B supply. Cathode is filament of filament-type tubes. If measurements are taken to ground the assumption is made that cathode is grounded, which it usually isn't, so the total voltage is read

without discrimination. This is a common error.

8. The statement of the inductance of a B choke as being "30 henries" has no significance, unless the current through the choke is stated or assumed, for the inductance declines with increase in current, so much so that many so-called "30-henry chokes," when used in B filters where 100 ma flow, have inductances of less than 5 henries. The statement "30 henries," however, has significance if the circuit is understood, hence where there is sufficient intimation of the amount of current flowing.

9. The d-c resistance should be low because the tube is intended for a circuit that has excellent regulation, being itself a contributant to such regulation because of its practically-constant voltage drop of 15 volts. If the choke resistance is high, the changes in current due to set performance would change the voltages considerably, i.e., work against good regulation. The inductance of the choke should be high, to maintain the desired excellence of filtration.

10. The tube may oscillate. A series r-f choke, 1.0 millihenry or more, in each plate leg, or a 1,000-volt mica condenser, about 0.01 mfd., from each plate to minus, will cure the trouble.

11. In the first instance the frequency of the test oscillator is being measured, for it is equal to the difference in frequencies at the two adjoining points in the receiver tuning. In the second instance points related harmonically to the receiver's fixed frequency are ascertained in the test oscillator without any ready means of knowing what the harmonic order and fundamental oscillator frequencies really are.

12. The coupling between antenna and set is loosened by the decreased series capacity, and therefore less of antenna resistance is introduced. The less the resistance, the less circuit loss a tube has to overcome to produce regeneration.

13. No, unless for reasons of deafness. The reason is that earphones are probably the most sensitive instruments used in radio.

14. A dynatron oscillator is one in which the current in the tuned circuit increases as the oscillation voltage decreases. This constitutes the negative resistance required for any oscillator, but is obtained by special voltaging of the elements of a tube, e.g., screen grid tubes 22, 32, 24 and 36, so screen voltage is critically lower than the plate voltage. The tuning coil is in the plate circuit. Dynatrons are inherently unstable. So are practically all oscillator tubes, but the characteristic is strongest in the dynatron. Any unstable tube can be stabilized.

15. More gain is derived from the intermediate level.

16. The limiting fixed resistor should be less than what the theoretical computation calls for, because a series rheostat is to be included, and the rheostat may be about 20 per cent of the theoretically-required fixed value, if the substituted fixed value is 10 per cent less than the theoretical value. The combination will enable greater total resistance than the theoretical value, which is sensible indeed, as the electromotive force in the battery may yield higher than normal battery voltage readings due to temperature effects. This is commonly referred to as a condition where the battery "reads too high."

17. Banana plugs or tips.

18. There is no direct identity between the two. Efficiency is a comparison of what is taken out as against what is put in, for any identity unit. Sensitivity is a comparison of the same sort but for an unrestricted number of units.

19. It would have to be done with a thermostat of the continuously-variable type. Suppose you wind a small spiral coil of phosphor bronze wire and the thermostatic element is arranged so that the coil will lengthen or shorten with changes of temperature. If this coil were connected in series with the other coil, there would at least be a partial compensation. Perhaps it

(Continued on next page)

Station Sparks

By Alice Remsen

LLOYD SCHAFFER ON DECK

Had a pleasant surprise this week. Was rehearsing a program in studio 3A at NBC, when who should walk in but Lloyd Schaffer, my old maestro from WLW. He had just arrived from Cincinnati, and told me he intended staying in New York, as he has three or four very good things coming through for him. Lloyd looked the picture of health and energy. We're due for a good gabfest in the near future. Here's wishing him plenty of luck in the big city.

HERE'S A GOOD IDEA

Ray Heatherton is playing quite a few vaudeville dates these days, booked by NBC. He still manages to cover his air-dates, however. . . . Ernest Cutting, the genial head of NBC auditions, is putting on a show over an NBC-WEAF network each Friday afternoon at 2:30 p.m. EST., which he calls "Airbreaks." This show has been designed by Mr. Cutting particularly to give professional artists a chance to be heard on the networks; no amateur talent will be used. The artists will be hand-picked by Mr. Cutting from among the thousands of aspirants who have had auditions at NBC. About one in a hundred is the average to be listed as desirable talent, but even after these artists are listed as good talent there is often no place for them on the air. These are the people who will get the "break" in "Airbreaks." Mr. Cutting conceived the idea for the program and will be in complete charge, hearing auditions, writing continuity, producing the show, introducing the artists and even conducting the orchestra. It is to be thoroughly understood that no amateurs will be used. All the artists will have had vaudeville, concert or local radio experience. . . .

FOUR WORTHWHILERS

Four entertainers, all of them comparative newcomers to network programs, have been signed by the Columbia Broadcasting System and now are allotted their own periods. They are Arthur Godfrey, Bill Huggins, Bob Standish and the Hurdy Gurdy Man. Three of these promising artists are products of Washington, D. C., where they first attracted attention through broadcasts over WJSV, Columbia's Capital station. Godfrey, now featured on the Metropolitan Parade series on Tuesdays and Thursdays at 3:30 p.m., first attracted the attention of Walter Winchell during early morning broadcasts from Washington, when Godfrey would "ad lib" anything that came to his mind. Bill Huggins, also from Washington, is a deep-voiced singer with a thick Southern accent; he may be heard Mondays at 4:00 p.m. and Fridays at 2:00 p.m. WABC. The Hurdy-Gurdy Man, whose right name is Giuseppe Pietro Bruno, is a native of Sicily; he is still in Washington, but is heard through WABC each Friday at 1:15 p.m. Bob Standish, the remaining member of this new group, is a high baritone, whose repertoire ranges from opera to rhythm numbers; he broadcasts each Tuesday and Thursday at 4:30 p.m. accompanied by the studio orchestra. . . . Peter Van Steeden and his orchestra have just signed for thirteen more weeks with the sponsor of his Wednesday night WEAF broadcast. Peter and his orchestra also broadcast dance music from the Hotel Gotham on Mondays at 6:45 p.m. WJZ, and Saturdays at 6:00 p.m. WEAF. . . .

GEORGE B. STORER HEADS FEDERAL

George B. Storer, of Detroit, has been made a member of the Board of Directors and Executive Committee of the Federal

Broadcasting Corporation, WMCA, New York, and has been elected President. Mr. Storer is widely known in the Middle West as a successful and progressive radio executive, owning or controlling the well-known stations CKLW, Detroit-Windsor, WSPD, Toledo, Ohio, and WWVA, Wheeling, W. Va. Mr. Storer has acquired an interest in the corporation. . . . Arthur Warren, young orchestra leader at La Rue Restaurant on Fifth Avenue, is building quite a reputation for himself among the society patrons of that establishment. His band provides dance tunes for luncheon, dinner and supper. WNEW, the new major radio outlet, has given him nine weekly broadcasts and is building him up as its feature orchestra, which is a great break for Warren. . . . At the Ambassador Hotel, Pancho, the famous Argentine maestro, has introduced a novel feature, composing and presenting special numbers in honor of prominent patrons—a sort of glorified song-laureate. . . . Max Meth, musical director of the Max Gordon musical comedy "Roberta," recently celebrated the fifteenth anniversary of his first public appearance under the baton of Walter Damrosch, when Meth, then eighteen, was appointed first violinist in the New York Symphony. . . . Jack Berger, the Hotel Astor musical director, has the unique distinction of being the only native New Yorker playing with his orchestra in a Broadway Hotel. . . .

SOUNDS ROMANTIC, ALL RIGHT

The song, "Under the Spell of Music," composed by Claire Majette, and recently introduced by her on an "Evening in Paris" program, is being considered as the musical frame for a romantic movie short. . . . Joe Emerson, WLW's Bachelor of Song, is now being featured over the Nation's Station every Friday evening at 6:15 in a series of broadcasts sponsored by the makers of Unguentine. He is heard with an orchestra under the baton of Joe Lugar; very glad to hear that the two Joes are doing so well. . . . Grace and Eddie Alberts are two youngsters who are making good on NBC networks. They do songs, harmony and rhyming patter and have a distinct style of their own. Should be a good commercial bet. . . . Fred Waring and his Pennsylvanians celebrated their fifteenth anniversary during the Ford Dealers program, March 18th. . . . Ruth Etting has again been captured by the movie-cameramen. She left Hollywood not long ago to resume broadcasting over the Columbia network, but no sooner did she get back East than Warner Brothers rushed her out to their Brooklyn studios to make a series of shorts. She'll work on them during the next six months. The first is to be called "Ruth Must Be Served." . . . "Ill Wind," a new song by Ted Koehler and Harold Arlen, was given its radio premiere last week, and proved to be a worthy successor to "Stormy Weather." . . . It is Freddy Martin's Orchestra which is heard with Groucho and Chico Marx on Sundays over the Columbia network, and those featured vocalists are Elmer Feldkamp and Terry Shand. . . . Emery Deutsch and his gypsy

violin may now be heard in a new weekly series of quarter-hour broadcasts over the Columbia network, on Mondays at 9:15 p.m. EST. . . . Ernest Hutcheson, distinguished concert pianist and Dean of the Juilliard Graduate School of Music in New York, has returned to the WABC-Columbia network for his third series of recitals; Sundays at 10:30 p.m. . . . Donald Lee tenor who sings over WHOM at 8:00 p.m. on Thursdays, is a former musical comedy actor, having appeared in "Princess Flavia," "My Maryland" and other shows. . . .

ELLINGTON A COMMERCIAL

Duke Ellington and his famous orchestra may now be heard over the NBC Coast network stations on a weekly series of commercial broadcasts for a coffee concern. . . . Mr. and Mrs. Jesse Crawford are back in New York. . . . Borrah Minevitch, dean of the harmonica, who is heard over WOR each Tuesday night at 8:30 o'clock, is writing a book on that instrument. . . . "Fifteen Minutes of Melody" is the title of a new musical program which is being heard over WGN, Chicago, every Saturday night at 10:00 o'clock, CST. . . . "Songs You'll Remember," featuring a dozen talented artists, including Russell Brown, the Three Rosebuds and Dorothy Perkins, is a new feature which is being presented by WSM, Nashville, Tennessee, the broadcasting service of the National Life and Accident Insurance Company, each Friday night at 7:00 o'clock. . . . WOR has combined with WLW and WGN for one program, that of Will Osborne and his Orchestra. It is rumored that these three stations will form the nucleus of a new chain. . . . It is also rumored that Ilomay Bailey and Lee Sims will be brought back to the air soon. . . .

ENTIRELY SURROUNDED BY BEAUTY

George Gershwin looked very bright and brilliant after one of his programs last week; surrounded by female admirers, the dapper George was all smiles. By the way, he makes all those complicated orchestral arrangements used on his programs, which is quite a job. . . . Mary Small is doing marvelous work on the Sunday Babo program. On a recent program her "surprises" were Robert Simmons, who did a fine piece of work with "The Touch of Your Hand," and "I Raised My Hat," and The Three X Sisters, whose "Eddie Cantor's Eyes" is by way of being a masterpiece of harmony-comedy, as was their "Three Little Pigs," also done on this program. These girls are the cleverest of the many sister trios now on the air.

Trade Considers Grading of All Types of Sets

Base pin numbering standards were recently recommended and now under consideration by Radio Manufacturers Association, Inc., is development of some plan for grading radio receivers. A meeting of the Committee on Receivers is planned under the chairmanship of E. T. Dickey. Police radio and also development of automotive radio are other especial fields in which the RMA engineers are immediately active.

A bulletin on radiation of receivers was sent recently to all RMA set manufacturers suggesting design of receivers to prevent certain types of radiation interference.

THE REVIEW

(Continued from preceding page)

would be enough to move one turn of the main coil in the same manner. Or another way would be to have the thermostat rotate a small turn inside the main coil. The adjustments would have to be made experimentally.

20. This is a sign of overloading of the receiver, usually detector or audio level.

BUSINESS BEST SINCE '30; BIG SUMMER SEEN

Following the satisfactory Fall and early Winter business, the radio industry is starting 1934 in the most favorable statistical position it has been able to achieve since 1930.

It now is on a more stable basis than at any time in its history, and fully capable of keeping pace with any other industry in the recovery movement. Inventories have been reduced to nearly one-quarter the size of their unwieldy proportions at the beginning of 1933, there is almost no distress merchandise on the market, and price-cutting is less in evidence. While the latter has limited the profits of some of the large operators, that have ample cash to purchase discontinued lines or merchandise offered in quantities, it makes conditions better for the average small dealer, and credit conditions among the smaller distributors have improved materially.

Some of the broadcasting companies, that have been showing red figures on their balance sheets for some time, recorded small profits at the close of 1933, as many national advertisers who substantially reduced their appropriations last Spring came back on the air in the Fall with augmented programs using more time.

Best Volume in Three Years

Volume of business in 1933 rose to the most satisfactory level in the last three years, in some cases running as high as 100 per cent., with the average increase ranging from 5 to 25 per cent. Thus far in the current year, it has not been unusual for volume of sales to exceed by 60 per cent. that of the same period of 1933, when merchandise could not be moved, even though it was offered at less than half the actual cost of production.

While some slowing down in demand is expected during the Summer, the widening popularity of automobile radios doubtless will take up much of this slack, as cars are being wired for radio sets as standard equipment, and the growing appreciation of radio beyond the realm of luxury is being counted upon to help maintain volume. Despite the strong current asset position of many of the large companies, the resumption of dividends is expected to await the return to a more profitable basis, according to a survey of the radio industry, which has just been completed by Dun & Bradstreet, Inc.

From the wholesale field, reports lack uniformity. Some firms find that sets retailing from \$89.50 up are moving out as fast as they can be received from the manufacturers, with midjets and the lower-priced sets practically in the discard. On the other hand, a number of firms complain of chaotic conditions existing since the first of the year, as some manufacturers dumped merchandise on the market, and retailers are buying only at forced sales on extremely favorable terms.

All-Wave Sets Moving

With the majority of wholesalers, however, sales during the last four months have been running 40 to 100 per cent larger than in the same period of the year preceding. All-wave sets constitute about 50 per cent. of the wholesalers' orders, and the new features which have been added to these units have proved a strong stimulus to demand.

Probably the outstanding feature of the radio industry has been the almost uninterrupted rise in sales. Commencing the up-

Tradiograms

By J. MURRAY BARRON

The electrical code, under which the radio industry is operating, is undergoing revision by NRA officials, following conferences with the trade held in Washington. The code for radio jobbers, offered by the Radio Wholesalers Association, is nearing completion.

* * *

The U. S. Internal Revenue Bureau reports that collections of excise taxes for January, 1934, on radio and phonograph products were \$415,358.83. This compares with similar 5 per cent. excise tax collections of \$283,425.27 in January, 1933. The excise tax collections on mechanical refrigerators in January, 1934, were \$145,541.11, compared with \$106,172.48 during January, 1933.

* * *

Radio Corporation of America, whose report for 1932 showed a net loss of \$1,133,586, reports a net loss for 1933 of \$582,094, an improvement of \$551,492. Gross income for 1933 was \$62,333,496, compared to \$67,361,143 in 1932, a decrease of 7.5 per cent. The cost of doing business was reduced 8.1 per cent. Net earnings were \$3,655,285, against \$5,075,901.

* * *

Carlo De Angelo, for a number of years supervisor of production and director of radio programs with N. W. Ayer & Son, has joined the Blackman Company as head of their radio department. Mr. De Angelo is well known as an actor and director, and while with the Ayer organization, over a hundred programs were produced under his direction, including the Eveready Hour, Eno Crime Club, Scott & Brown Circus Stories, etc. Among the programs which he will direct for the Blackman Company are those for the Hudson Motor Car Company and Procter & Gamble.

ward trend in the Summer of 1933, demand broadened to such an extent during the final quarter that some retailers were enabled to report totals for the year nearly four times larger than those for 1932, with a general average of around 70 per cent.

While the pace set during the final quarter of 1933 has not been maintained fully, current sales are running at least 50 per cent. larger than during the opening months of last year. Better dealer distribution has helped to extend sales, particularly in the higher-priced sets, while in the agricultural districts the battery sets continue to sell well, some retailers shipping more of these than in several years. The larger distribution of money to cotton growers has served as a distinct stimulant to buying in the South.

The best-selling items are those in the bottom and top categories, with an actual shortage in these classes in some makes, although the medium-priced sets, which retail from \$40 to \$125 are beginning to move better. Numerically, table models retailing under \$50 still hold the lead, but there has been a decided increase during the last three months in the demand for console sets.

The demand for "all-wave" sets is increasing rapidly, and as these do not come within the lowest price brackets, the average unit price for all sets sold is higher than it was at the same time last year. Prices in the leading lines have advanced 20 to 30 per cent. since last July, with only small increases recorded since Fall. As the general trend is toward firmness, this is viewed as a forerunner of at least moderate mark-ups before the close of the Spring season.

Collections are off about 5 points, as compared with 1933, which is considered a satisfactory showing, in view of the increased volume of shipments this year, with the resultant increases in receivables not due.

While the number of firms going into bankruptcy in the radio industry has been on

Erwin, Wasey & Company, Ltd., 230 North Michigan Avenue, Chicago, announce a new type radio entertainment for the Realsilk organization with their own orchestra organized by Charles Previn, conductor for "Of Thee I Sing" and also for five seasons as director of the St. Louis Municipal Opera. In the new Realsilk orchestra each member will be also a solo artist. The series will start over the WJZ network at 6 p.m., CST, on April 1st.

* * *

It has been announced that the meeting nights for the New York Short-Wave Club will be Thursdays, in place of Fridays, and the place, as usual, the 63rd Street branch of the Y.M.C.A.

* * *

From Try-Mo Radio Co., Inc., comes the announcement that after May 1st its branch store, now at Greenwich and Dey Streets, will move to 179 Greenwich Street where a bargain basement with enlarged departments will be one of the outstanding features. Now at the Dey Street store many exceptional buys are offered before moving.

* * *

Frank Grimes, a pioneer in transmitters, will be back at the old stand with the Try-Mo Radio Co., 85 Cortlandt Street after May 1st. Sam Lager, now general manager at the 178 Greenwich Street store, will be located at the store across the street, 179 Greenwich Street.

* * *

Those of us who remember the older days in radio, when kits were the thing and every kitchen was a radio work shop, it might be surprising to learn that all indications point to a return of those days.

the decrease since 1930, and in 1933 totalled only 134, as compared with 193 in 1932, or a decline of 59, the same good showing did not appear in the money loss which these failures involved. For, the total of defaulted indebtedness of the 134 firms that failed in 1933 reached \$5,533,499, in contrast to \$3,805,673 for the 193 failure in 1932. This was an increase of \$1,727,826, or 45.4 per cent. Compared with the liabilities of the bankrupt firms in 1931, however, when an all-time high of \$9,067,804 was recorded, the 1933 figures represent a decrease of 38.7 per cent.

Thus far in the current year, manufacturers appear to be in a stronger financial position than the distributive branch of the industry. The bankruptcy of one large wholesaler for more than \$1,000,000 in January brought the failure loss for that month for wholesalers and retailers alone to \$1,294,562, in contrast to \$1,813,980 set down for the entire twelve months of 1933.

November Employment Highest

Washington.

The official indexes of the Department of Labor of employment and payrolls in the radio industry by months in 1933 were as follows:

(12 mo. average 1926-100.0)

	Employment	Payrolls
January	57.9	41.9
February	61.9	45.5
March	61.0	42.0
April	67.2	50.5
May	81.3	62.3
June	92.1	65.5
July	94.1	55.7
August	108.2	73.9
September	133.6	91.2
October	162.4	125.2
November	169.3	131.9
December	149.6	112.6

FREE

handy MANUAL

of short wave information and hookups with each

SCOUT

One Tube Short Wave Kit or Receiver

Tunes from 15 to 200 meters. Kit of parts with 4 Bruno coils . . . \$3.95

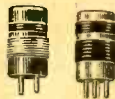
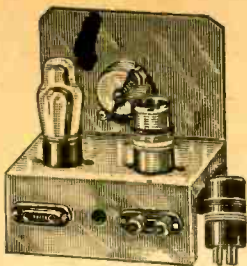

TRY-MO RADIO CO., Inc.
85 Cortlandt St., New York, N. Y.
179 Greenwich St.
Visit our big Bargain Basement at 179 Greenwich St.

NEW PRICES TROUBLE SHOOTER'S MANUAL, Nos. I, II and III

Having assembled 2,000 diagrams of commercial receivers, power amplifiers, converters, etc., in 1,200 pages of Volume No. 1 of his Perpetual Trouble Shooter's Manual, John F. Rider, noted radio engineer, has prepared Volume No. 2 on an even more detailed scale, covering all the latest receivers. Volume No. 2 does not duplicate diagrams in Volume No. 1, but contains only new, additional diagrams, and a new all-inclusive information on the circuits covered.

Volume No. 3 (Recently Issued). Order Cat. RM \$7.50
Volume No. 2—Perpetual Trouble Shooter's Manual, by John F. Rider, Shipping weight 6 lbs. Order Cat. RM-VT @ \$6.50
Volume No. 1 (8 lbs.). Order Cat. RM-VO @ \$7.50
Rider's Trouble Shooter's Manual, No. IV. Brand new, up to 1934..... \$7.50

We pay postage in United States on receipt of purchase price with order. Canadian, Mexican and other foreign remittances must be in funds payable in New York.

RADIO WORLD
145 West 45th Street New York City

Quick-Action Classified Advertisements

7c a Word—\$1.00 Minimum

YOUNG MAN 26 YEARS OF AGE, R.C.A. Institutes, Inc., and Capitol Radio Engineering Institute, Inc., graduate, desires moderate position as assistant in either Radio Laboratory or Radio Service Shop; has done some experimental work at home and speaks and writes Spanish correctively. Write Michael A. Alvarado, 322 W. 113th St., New York City.

STAMMERERS' Home remedy—587 Saylor, Elmhurst, Illinois.

ATTENTION! Operate newspaper clipping bureau. \$30.00 week. Complete instructions, 25c. Fireside, Royal Oak, Mich.

MODERN TUBE INDEX, all tubes, all the dope all manufacturers, socket connections, everything Most complete of all. Sheet 21 x 27 inches. Price 25c. RADIO WORLD, 145 West 45th Street. New York, N. Y.

"RADIO TROUBLE SHOOTING," Second Edition, by E. R. Haan. Contains the latest on A.C. receivers, dynamic speakers and television. A practical book for practical men. Contains a special chart showing all possible radio troubles and the way to detect them. Size 6 x 9 inches. 361 pages, 300 illustrations. Flexible binding. Price \$3.00. RADIO WORLD, 145 W. 45th St., New York City.

"DRAKE'S CYCLOPEDIA OF RADIO AND ELECTRONICS." The Standard Reference Book for Radio Men. A 5th Edition of the famous Drake's Cyclopaedia covering the whole field of radio and the allied arts in one handy volume. 1048 pages, 1178 illustrations, 130 tables, 105 graphs. Price, \$5.00 net. RADIO WORLD, 143 West 45th St., New York City.

TUNING UNIT FOR TEST OSCILLATOR

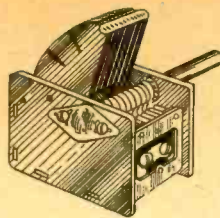

HERE is your very first opportunity to get the parts for constructing a universal, modulated test oscillator to cover fundamentals from 135 to 380 kc, and read higher intermediate frequencies and the entire broadcast band, by harmonics, all imprinted right on the dial. That is, the oscillator will be direct frequency-reading. The parts consist of one metal-etched scale, one metal escutcheon, one 0.000406 tuning condenser with trimmer built in, one oscillation transformer (secondary inductance accurate to 0.1 per cent.), and one knob for condenser. Circuit diagram supplied for universal model modulated test oscillator (90-120 volts a.c., d.c. or batteries, same oscillator works on all three). Instruction sheet for lining up at broadcast and intermediate frequencies included. Lins up the oscillator with one adjustment on broadcast band, beating with some station on 1,200 to 1,400 kc. Whole dial then will track. Order PRE-TUTO and send \$6.00 for one-year subscription for (52 issues). Sent postage prepaid.

MICA-DIELECTRIC Intermediate Transformers

For 465 kc or 175 kc i.f. we offer doubly-tuned transformers, with mica-dielectric condensers built in, all enclosed in 4-inch high aluminum shield, 2-1/16-inch diameter. Quantity is at left. Sent postpaid.

Single Transformer

- (1) PRE-MD-465 . . . \$2.00 subscription, 16 issues
- (1) PRE-MD-175 . . . \$2.00 subscription, 16 issues
- (2) PRE-MDD-465 . . . \$4.00 subscription, 34 issues
- (2) PRE-MDD-175 . . . \$4.00 subscription, 34 issues
- (3) PRE-MDDD-465 \$6.00 subscription, 52 issues
- (3) PRE-MDDD-175 \$6.00 subscription, 52 issues

The following highest-grade, licensed, brand-new, 10-day-replacement-guarantee tubes are offered as premiums.

One Tube for \$1.00 Subscription, 8 Issues. 01A, 01AA, 1V, 12Z3, 112A, 24A, 26, 27, 30, 31, 35, 36, 37, 38, 39, 45, 47, 51, 56, 71A, 80, 82.

Any two of above tubes for \$2.00 Subscription (16 Issues), any three for \$3.00 Subscription (24 Issues), any six for one-year Subscription (52 Issues).

Complete Selection of Tubes



AIR-DIELECTRIC Intermediate Transformers

For unequalled maintenance of the frequency to which the intermediate channel is adjusted, air-dielectric tuning condensers must be provided. These are supplied on Isolantite forms, and are made by one of America's premier precision radio parts manufacturers. Quantity at left.

- (1) PRE-AD-465 . . . \$6.00 subscription, 52 issues
- (1) PRE-AD-175 . . . \$6.00 subscription, 52 issues
- (2) PRE-ADD-465 . . . \$12.00 subscription, 104 issues
- (2) PRE-ADD-175 . . . \$12.00 subscription, 104 issues
- (3) PRE-ADDD-465 \$18.00 subscription, 156 issues
- (3) PRE-ADDD-175 \$18.00 subscription, 156 issues

One Tube for \$1.50 Subscription, 13 Issues.

1A6, 5Z3, 2A5, 2A6, 2A7, 2B7, 6A3, 6A7, 6B7, 6F7, 25Z5, 22, 32, 33, 34, 41, 42, 44, 46, 49, 53, 55, 57, 58, 59, 67, 75, 77, 78, 8S, 83V, 84, (6Z4), 85, 89, 483, 485.

Any two of the \$1.50 group for \$3.00 Subscription (26 Issues), any four for \$6.00 Subscription (52 Issues).

TUBES SENT POSTAGE COLLECT.

SPECIAL SHORT-WAVE TUBES AND SOCKETS

A new dielectric has been introduced that shows most remarkable properties for high frequencies. The heat losses are not discernible at 75 centimeters. The losses decrease as the frequencies increase, contrary to what hold for all other known dielectrics. The new material is called Victron. It was developed by the United States Rubber Company, although it is not rubber. Special processing is necessary to work this material, hence cost of production runs high, but the results are most astonishing, particularly as tubes that otherwise stop oscillating at 10 meters or so oscillate at lower than 5 meters when victron is used as tube base.

Send \$2 for 16-weeks subscription and select one of the following Victron-base tubes: 30, 56, 57, 58, or any two for \$4 subscription (34 weeks) or any three for one-year subscription (52 issues) or all four for \$8 subscription (60 issues).

Four and five-hole sockets, made of Victron, are for use with Victron-base tubes for preservation of gain, and for use as precision, low-loss coil receptacles. Select one socket for \$1 subscription (8 weeks), two sockets for \$2 subscription (16 weeks), three sockets for \$3 subscription (24 weeks).

(Victron base tubes and socket sent postage prepaid.)

VITAL BOOK

The biggest help any one can get who desires to wind radio-frequency coils for any frequency from just below the audio range to the fringe of ultra frequencies is to have a book that tells just what inductance is required for the condenser one possesses, and just how many turns of any kind of wire on any sensible diameter are needed to produce that inductance. "The Inductance Authority," by Edward M. Shiepe, gives you just that information, to an accuracy of 0.1 Per cent. Send \$3 for a six-months subscription (26 issues) and order PRE-IA sent postpaid.

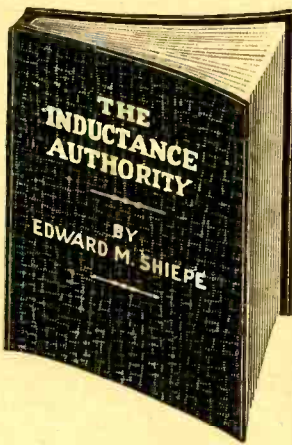

POWER TRANSFORMER

Primary—105-130 volts. Secondary A—2.5 volts, center-tapped. Secondary B—110 volts, no center tap. Splendid for powering a-c test oscillator or any other rectifier for not more than three small tubes.

Small Power Transformer

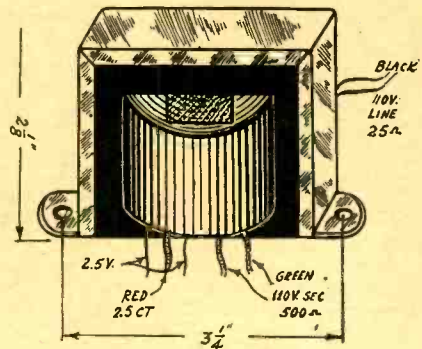

Order PRE-SPTR and send \$1.50 for three-month subscription (13 weeks) postpaid.

RADIO WORLD, 145 WEST 45th STREET, NEW YORK, N. Y.

LAPEL MICROPHONE

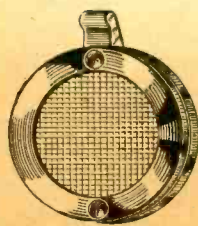

A single-button carbon-granule lapel microphone, impedance 200 ohms, requiring 4.5-volt excitation, of good frequency characteristics, and both handy and inconspicuous. Outside diameter, 1 1/4 inches. The case is chromium-plated brass. The excitation may be provided by introducing the microphone in a cathode circuit carrying around 20 to 25 milliamperes, or a 4.5-volt C biasing battery may be used. Net price, \$2.95.

RELIABLE RADIO COMPANY
145 West 45th Street, New York, N. Y.

SOLDERING IRON FREE!

Works on 110-120 volts AC or DC, power, 50 watts. A serviceable iron, with copper tip, 5 ft. cable and male plug. Send \$1.50 for 13 weeks' subscription for Radio World and get these free! Please state if you are renewing existing subscription.

RADIO WORLD
145 West 45th St. N. Y. City

Subscribers! Important!

Note subscription expiration date on wrapper containing your copy of RADIO WORLD. If nearing expiration date, please send in renewal so that you will not miss any copies. Subscription Dept., RADIO WORLD, 145 W. 45th St., New York City.

People Laugh— at a \$12 Price for a Precision Test Oscillator!

IT does sound odd to hear the word "precision" linked with a price of "\$12," especially as there is no competing frequency-stabilized Test Oscillator selling under \$75. What kind of a Test Oscillator can it be, at \$12? Well it is a universal type, meaning that the same model works on 90 to 120 volts of a.c. (any frequency), d.c. or B batteries, and never requires any separate source of filament excitation.

"Ah, yes," may be the reaction, "it is a universal type, and so it feeds through the a-c or d-c line, even through batteries, if such are used." Well it *doesn't*. "And," the skeptical may continue, "it lacks that vital requirement, an attenuator, so that the output may not be regulated, and sets using automatic volume control can not be peaked." Well, it *has* an attenuator, one that is 100 per cent. effective. "Well, then, there is no direct-reading frequency-calibrated scale, and you have to consult a chart every time you want to make a measurement," the doubter may go on. But the scale is frequency-calibrated and direct-reading.



Model
30-AB

\$12

Complete
with Tubes

"EVEN so," the contrary story goes, "the 132 kc frequency of the Atwater-Kent intermediate channels can't be reached—the oscillator does not go that low." But it *does* go that low and just a trifle lower! "Then it isn't selective in all uses, and at all settings," the challenger assumes. But it is *decidedly and uniformly selective*. "Of course," is the next objection, "it will not zero beat at all settings and in all uses." Well, it *will* and it *does*. "At least, the output is wobbly, so you can't tell resonance exactly, even with an output meter." Yet the output is remarkably *steady* and an output meter (not a part of the Test Oscillator) will not wobble at all. "Then the accuracy can't be high." But it is high. The frequency generated is constant to one part in 100,000, and the scale itself, 132 to 380 kc fundamental, with *all* higher

important intermediate frequencies imprinted plainly thereon, and the broadcast band, besides, on another tier, may be read to a mechanical accuracy of better than 1 per cent. "Well, then, the oscillator must be a good one and well worth the money," is the inevitable concession. Certainly it's a good one—as good a one as you will need—and well worth more than triple the price asked.

Extreme pains and care are taken in the preparation and design of the Model 30-AB Test Oscillator. As an example, more than 50 hours were spent in calibrating and re-calibrating the scale until the mechanical accuracy of reading of the hand-made sample was ½ per cent., although in production this can not well be held to much better than 1 per cent., due to the variable condenser. The coil's inductance is held accurate to 0.1 per cent. Every place that accuracy could be improved it has been improved. Closer and better electrical values were easy enough, but holding a mechanical system (coincidence of dial scale with generated frequency) to an accuracy of better than 1 per cent. is admittedly a production feat.

Not only is the oscillator reliable, accurate, universal and inexpensive, not only is it applicable to intermediate and broadcast frequencies, but it can be used reliably for lining up and calibrating short-wave receivers by a special method we devised. The short-wave feature is not direct-reading, but it is simple and dependable, and it gives an all-wave aspect to the new Model 30-AB.

You run no risk whatever when you order one of these Test Oscillators. Enclose \$12, order Model 30-AB. Try out the Test Oscillator for ten days after receipt. If for any reason, or for no reason, you decide to reject it, return it prepaid, and your purchase-money will be refunded promptly. Nobody has ever returned a Model 30-AB Test Oscillator.

The calibration of the Model 30-AB is not disturbed by tube replacement. Two tubes are used. One is the 30 r-f oscillator. On line a.c. this is constantly modulated by the hum frequency when the oscillator is tuned to resonance with the measured circuit. On d.c. or batteries a separate neon tube is used as audio oscillator, and the option of modulated-unmodulated service is enjoyed, by switching.

Model 30-AB is enclosed in a black crinkle-finish shield cabinet and has a black Formica front panel. It measures 5.5 x 7.5 x 3 inches overall and weighs 5 lbs. for shipping. Compact, effective, universal, it solves the service man's and experimenter's needs as does no other Test Oscillator on earth at anywhere near the price.

Designed by Herman Bernard, the Model 30-AB Test Oscillator is manufactured under his personal supervision. Order one to-day.

EDWARD M. SHIEPE

135-H LIBERTY STREET

NEW YORK, N. Y.

Long-Distance Telephone: New York City, Rector 2-6650