

QST

DEVOTED ENTIRELY TO AMATEUR RADIO

PUBLISHED BY THE AMERICAN RADIO RELAY LEAGUE

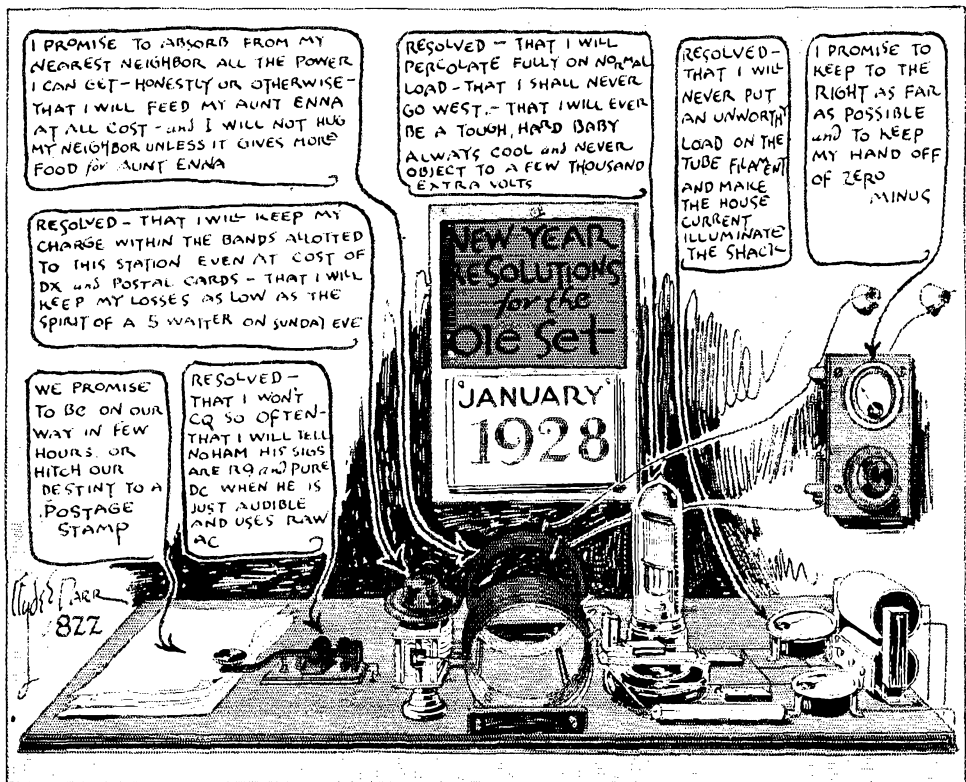

January
1928

25¢

Cunningham RADIO TUBES

CX326  C327



*Answer
A C
requirements
in modern
Electric*



Radio Reception

THE popular demand for the latest and most improved A C power receivers calls for the latest development in A C tube construction.

Cunningham A C tubes CX-326 and C-327 are outstanding in their performance and will bring your A C power receiver up to its highest efficiency.

See that these two tubes are doing their duty along with other Cunningham tubes in your A C receiver.

*With A C Power
Receivers Use
Cunningham
A C Tubes*

E. T. CUNNINGHAM, INC.
NEW YORK CHICAGO SAN FRANCISCO

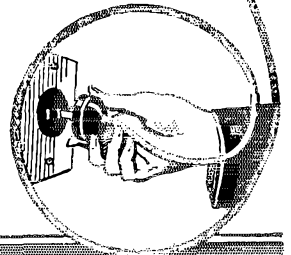

Iron *and* Wire

Plus

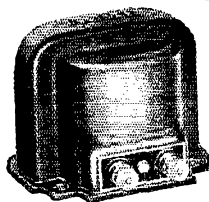

Iron and wire--*plus*
long proved suc-
cess--*plus* exacting
scientific research
--*plus* service--*plus*
guaranteed quality

Insist on
Acme Transformers

Acme Purchasers
have at their dis-
posal the free serv-
ices of a highly suc-
cessful engineering
department.

Insist on
Acme Transformers

So thorough was
the research pre-
ceding the manu-
facture of the first
Acme, its design
has never changed.

Insist on
Acme Transformers

Skilled workmen,
superior factory
equipment, rigid inspec-
tion, and an absolute
guarantee, make it worth
your while to

Insist on
Acme Transformers

ACME TRANSFORMERS

ACME APPARATUS CORPORATION

CAMBRIDGE, MASS.

Say You Saw It In QST—It Identifies You and Helps QST

CARDWELL TRANSMITTING

OXO RADIO CO.
1023 THIRD AVE
SEATTLE, ORE.

TRANSMITTING
EQUIPMENT
LABORATORIES
3675 SO. MONETA AVE.
LOS ANGELES,
CAL.

NEILSON
RADIO CO.
311 NORTH
CENTRAL
AVE.
PHOENIX ARIZ.

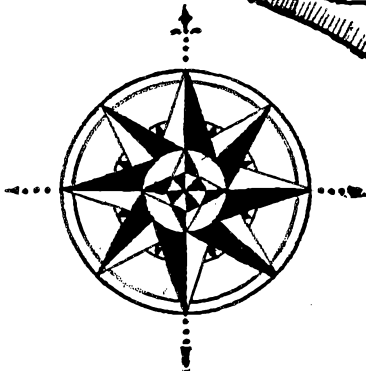

WHEN you crave to raise the jolly old power, and you need a flock of new stuff, and you dig down into the bottom of the sock for the last lone jit—

then

YOU want to be dawgawn sure that you can trust the bird you're buying thru to see that you get good stuff.

OF course, if it's Cardwell Condensers you demand you know they will be fine business, but the rest of the order—h-m-m-m?

NOW, we know darn well that for Cardwell stuff to show up best, it's gotta be in a set with other good parts

SO

HERE are some jobbers who do business on the basis of—Best of Quality, Honest, Quick Service, No Substitution, and an iron clad Guarantee that Anything they sell has got to be good. And they handle all the other GOOD parts along with Cardwell Condensers. You can deal with them with absolute confidence that they'll treat you right.



They're
Cardwell
Jobbers!



so they're good!



Cardwell

“THE STANDARD”

CONDENSER

JOBBER

ARE RELIABLE

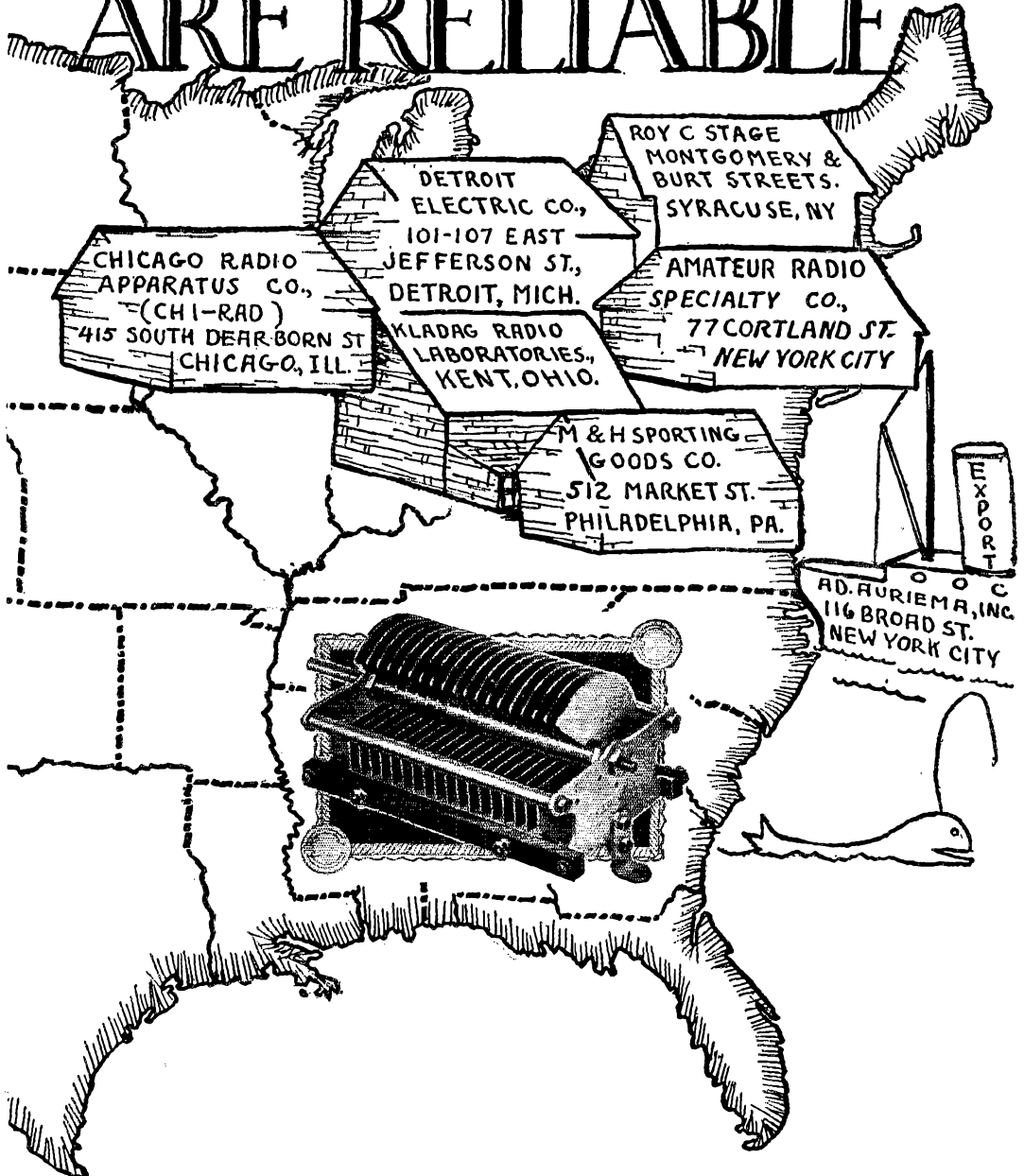

Condensers

OF COMPARISON"

For the Best in Short Wave Reception

Build the Aero Short Wave Receiver

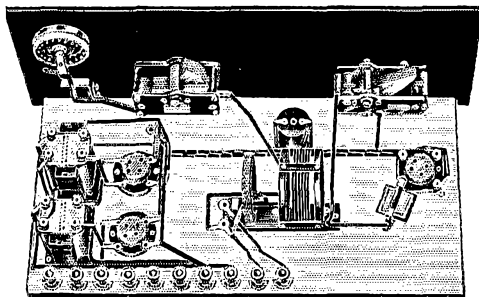

Superlative performance in every respect assured by carefully selected parts around which set is built.

If you want a *real* short wave receiver—a set possessing unusually long range, fine selectivity, great power and splendid tone qualities—build the AERO SHORT WAVE RECEIVER.

This excellent receiver is neat and compact, and is flexible to an unparalleled degree. It has a normal range of 15 to 130 meters, and completely covers U. S. bands 20, 40, and 80 meters. Range can be reduced or increased if desired (see note below). Any amateur desiring the very best in short wave reception should certainly build this set.

These Prominent Manufacturers' Products Make Possible Its Excellent Performance

AERO PRODUCTS, Inc.

Supersensitive AERO Coils, in the form of the AERO Low Wave Tuner Kit, play a big part. This kit consists of 3 interchangeable coils. Special patented construction reduces high frequency losses to a minimum. Price of kit, \$12.50. You can lower range of set to 13 meters with AERO INT. 0, or increase range to 725 meters with AERO INT. 4 and INT. 5. These coils priced at \$4.00 each. The AERO Choke 60 and AERO Foundation Unit are also used.

AMSCO PRODUCTS, Inc.

AMSCO Condensers are another important factor in the AERO SHORT WAVE. One .00014 condenser and one .00025 condenser are used. These list at \$2.75 and \$3.00 respectively. AMSCO parts are noted for their accuracy, dependability and fine construction.

THORDARSON ELECTRIC MFG. CO.

THORDARSON radio transformers are particularly desirable in the AERO RECEIVER. For code work the R-151 6 to 1 ratio transformer gives maximum amplification at 500 cycles. For short wave reception of broadcasting type R-152 or R-200 will give excellent volume and tone quality. As used in this set, these transformers leave nothing left to be desired.

YAXLEY MFG. CO.

You'll like the outstanding quality and neat finish of the YAXLEY battery switch, resistances, and rheostat. These items contribute much to this receiver's beautiful finished appearance and electrical efficiency.

BENJAMIN ELECTRIC CO.

Benjamin sockets insure utmost electrical efficiency. That's why they're specified in this receiver.

Any or all of these specified parts are available at your radio dealers. Get them today. For literature or further information regarding the AERO SHORT WAVE RECEIVER address

AERO PRODUCTS, Inc.

Dept. 16

1772 Wilson Ave.

Chicago, Ill.

Section Communications Managers of THE COMMUNICATIONS DEPARTMENT, A. R. R. L.

Eastern Pennsylvania		SRQ	ATLANTIC DIVISION		
Maryland-Delaware-District of Columbia*		3AB	IL M. Walleze	597 No. James St.	Hazleton
Southern New Jersey		3EH	A. B. Goodall	1824 Inglezide Terrace	Washington, D. C.
Western New York		3GJ	H. W. Densham	140 Washington St.	Collingswood
Western Pennsylvania		3XE	C. S. Taylor	598 Masten St.	Buffalo
			G. L. Crossley		State College
			CENTRAL DIVISION		
Illinois	2AAW	W. E. Schweltzer	4264 Hazel Ave.	Chicago	
Indiana	9C9Y	D. J. Angus	310 N. Illinois St.	Indianapolis	
Kentucky	9ARU	D. A. Downard	116 No. Longworth Ave.	Louisville	
Michigan	3CEP	Dallas Wise	9187 Falcon Ave.	Detroit	
Ohio	8BYN	H. C. Storek	694 Carpenter St.	Columbus	
Wisconsin	9VD	C. N. Crapo	413 Newton Ave.	Milwaukee	
			DAKOTA DIVISION		
North Dakota	9EFN	G. H. Molr	618 11th Street, South	Fargo	
South Dakota	9DB	F. J. Beck		Millbank	
North Minnesota	9EGU	C. L. Barker		Henning	
South Minnesota	9BYA	D. F. Cottam	3538 Third Ave. So.	Minneapolis	
			DELTA DIVISION		
Arkansas	5A1P	Leonard Clippard	2498 North Pierre St.	Little Rock	
Louisiana	5UR	C. A. Freitag	129 Camp St.	New Orleans	
Mississippi	5AKP	J. W. Gullett	1708 23rd Ave.	Meridian	
Tennessee	4KM	L. K. Rush	4 Second St.	Bemis	
			HUDSON DIVISION		
Eastern New York	2ADH-2AXR	Earle Deaoux	Box 113	Yonkers	
N. Y. C. & Long Island	2CWR	F. H. Mardon	1309 W. Farms Rd.	N. Y. C.	
North New Jersey	2WR	A. G. Wester, Jr.	50 Princeton St.	Maplewood	
			MIDWEST DIVISION		
Iowa	9BKY	A. W. Kruse	Rt. 6, Box 19	Akron	
Kansas	9DNG	E. S. McKeever	1317 Mich. St.	Lawrence	
Missouri	9RR	L. B. Lutzere	8010 Mercer St.	Kansas City	
Nebraska	9BYG	C. B. Delhi	5695 Cedar St.	Omaha	
			NEW ENGLAND DIVISION		
Connecticut	1RM	H. E. Nichols	82 Elmwood Ave.	Bridgeport	
Maine	1B1G	Frederik Best	13 E. Crescent St.	Augusta	
Eastern Massachusetts	1UE	E. L. Bartley	155 Billings Rd.,	Norfolk Downs	
Western Massachusetts	1DR	A. H. Carr	30 Vassar St.	Warecester	
New Hampshire	1ATJ	V. W. Hodge	227 Main St.	Claremont	
Rhode Island	1BYJ	D. B. Fancher	92 Sumner St.	Westerly	
Vermont	1AJG	C. T. Kerr		Poultney	
			NORTHWESTERN DIVISION		
Alaska*	7DE	L. H. Machin	Box 452	Cordova	
Idaho	7ST	Henry Fletcher	1610 N. 10th St.	Boise	
Montana	7AAT-AKF	O. W. Viers		Red Lodge	
Oregon	7PP	K. H. Wright	310 Ross St.	Portland	
Washington	7FD	Otto Johnson	3340 30th Ave. W.	Seattle	
			PACIFIC DIVISION		
Hawaii*	6BDL	John A. Lucas	Box 1142, Fort Shafter	Oahu	
Nevada	6UO	C. B. Newcombe		Yerlington	
Los Angeles	6AM	D. C. Wallace	109 W. Third St.	Long Beach Calif.	
Santa Clara Valley	6NX	P. J. Quement	252 Hanchett Ave.	San Jose	
East Bay	6ZX	P. W. Dann	1821 Chestnut St.	Berkeley	
San Francisco	6VR	J. W. Patterson	1338 Fell St.	San Francisco	
Sacramento Valley	6CRS	C. P. Mason	2330 N. St.	Sacramento	
Arizona	6ANO	D. B. Lamb	229 W. First St.	Mesa	
Philippines*	6PIAT	Jose E. Jimenez	835 San Fernando St.	Manila	
San Diego	6BQ	G. A. Sears	236 Ronair St.	La Jolla	
			ROANOKE DIVISION		
North Carolina	4JR	R. S. Morris	413 S. Broad St.	Gastonia	
Virginia	3CA	J. F. Wohlford	118 Cambridge Ave.	Roanoke	
West Virginia	8BSU-8ED	C. S. Hoffman	126 Chantal Court	Wheeling	
			ROCKY MOUNTAIN DIVISION		
Colorado	9CAA	C. K. Stedman	1641 Aldon St.	Denver	
Utah-Wyoming	6RM	Don C. McRae	214 Belvedere Apts.	Salt Lake City	
			SOUTHEASTERN DIVISION		
Alabama	5AJP	A. D. Trum	217 Catoma St.	Montgomery	
Florida	4LK	C. E. Ffolukes	592 Spearing St.	Jacksonville	
Georgia-South Carolina-Cuba-Porto Rico-Isle of	4KU	H. L. Reid	11 Shadowlawn Ave.	Atlanta	
			WEST GULF DIVISION		
Northern Texas	5AJT	W. B. Forrest, Jr.	592 Royal St.	Waxahachie	
Oklahoma	5APG	K. M. Phret	2904 N. Robinson St.	Oklahoma City	
Southern Texas	5YK	E. A. Sahn	146 N. Academy St.	New Braunfels	
New Mexico	5TT	L. E. Radka		Tucumanari	
			MARITIME DIVISION		
Newfoundland	8AR	Loyal Reid	Aralon House	St. Johns	
New Brunswick	1E1	T. B. Lacey	620 N. B. Power Co	St. John	
Nova Scotia	1DD	W. C. Borrett	14 Sinclair St.	Dartmouth	
Prince Edward Island	1BZ	P. W. Hyndman	25 Fitzroy St.	Charlottetown, P. E. I.	
			ONTARIO DIVISION		
Ontario	9BJ	W. Y. Sloan	167 Close Ave.	Toronto	
			QUEBEC DIVISION		
Quebec	2BE	Alex Reid	169 Logan Ave.	St. Lambert	
			VALALTA DIVISION		
Alberta	4GT	A. H. Asmussen	19723 111th Ave.	Edmonton	
British Columbia	5BJ	E. S. Brooks	670 Forestry Dept.	Radio Court House, Vancouver	
			PRAIRIE DIVISION		
Manitoba*	4FY	D. B. Sinclair	205 Cambridge St.	Winnipeg	
Saskatchewan	4FC	W. J. Pickering	514 19th St. W.	Prince Albert	

*Temporary officials appointed to act until the membership of the Section concerned choose permanent SCMs by the nomination and election.

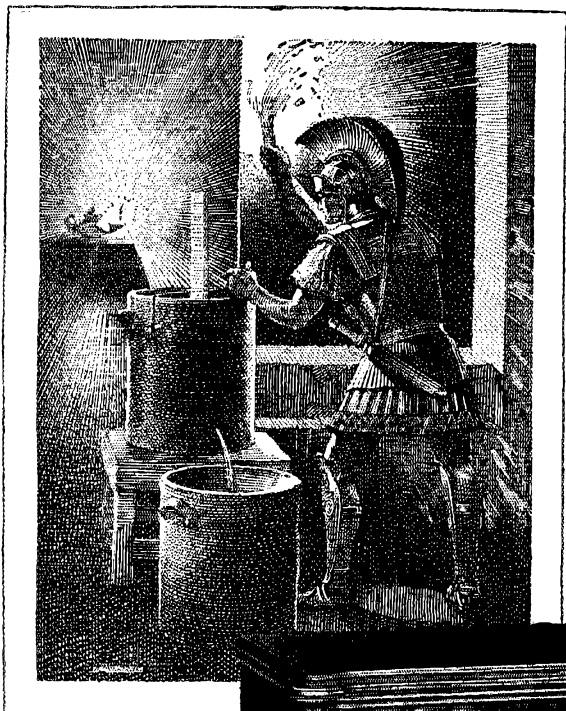

About 300 B. C. the Greeks sent messages by means of the Clepsidra. In two stations were water jars of equal size in which floated marked rods. On signal by torch or flag, plugs were pulled. When the rods lowered to a certain mark, at another signal both plugs were reinserted. The rods in both towers dropping to the same mark, the message was known.

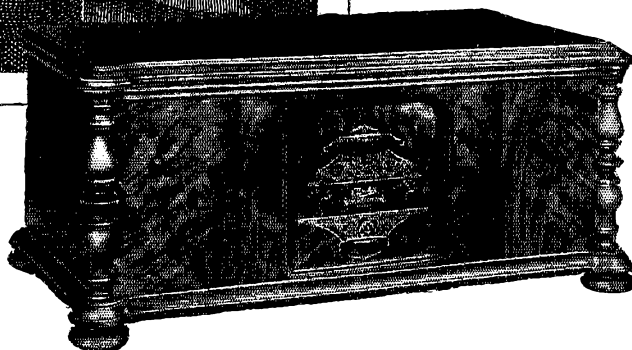

Selectivity—Turn the dial of a Grebe Synchronphase Seven. Stations come in—clean, full-toned. No overlapping of programs—station separation is sharply defined.

The tone of the Synchronphase Seven, especially when combined with the Grebe Natural Speaker, is unrivaled in naturalness. Its one-dial control assures simplic-



ity of tuning that is remarkable. Grebe construction, backed by eighteen years of making nothing but the highest grade radio apparatus, guarantees the durability

of these superior qualities. Grebe Synchronphase Seven, \$135; Grebe Natural Speaker, \$35. Send for Booklet Q; then ask your dealer to demonstrate, in your home, that you can "get it better with a Grebe."

GREBE

SYNCHROPHASE

RADIO

A. H. Grebe & Company, Inc., 109 West 57th Street, New York City
 Factory: Richmond, Hill, N. Y. Western Branch: 443 So. San Pedro St., Los Angeles, Cal.
 Makers of quality radio since 1909



QST



The Official Organ of the A.R.R.L.

VOLUME XV

JANUARY, 1928

NUMBER 1

Editorials	9
Election Results	11
A General Purpose Device	Howard Allan Chinn 12
The Amateur and the International Radiotelegraph Conference	K. B. Warner 15
This Amateur Phone Business	P. C. Lackey and Dean Spencer 23
Standard Frequency Transmissions	25
Municipal Ordinances on Radio Transmission Unlawful	A. L. Budlong 26
Grinding of Quartz Plates	F. G. Watts 27
Radio Frequency Chokes for Receivers	Glenn H. Browning 31
New Station Licenses	33
A Portable Power Supply	Rudolph Sturm 34
Horace A. Beale Jr.	36
The Helpful Audio Filter	37
Southeastern Division Florida Convention	38
nu3CAB	39
Rotten Bunk	The Old Man 42
Matching the Transmission Line to the Antenna	Walter Van B. Roberts 43
The Unimportance of Short Leads	L. W. Hatry 45
Admiral Bullard Dies	47
Experimenters' Section Report	48
Some Special Uses of the UX-222	Harold P. Westman 49
Re: The International Tests	51
I. A. R. U. News	52
Calls Heard	53
Correspondence Department	54
Financial Statement	62
References and Book Reviews	64
Hamads	91
QRAs	93

QST is published monthly by The American Radio Relay League, Inc., at Hartford, Conn., U. S. A.
Official Organ of the A.R.R.L. and the International Amateur Radio Union

Kenneth B. Warner (Secretary, A.R.R.L.),
Editor-in-Chief and Business Manager

F. Cheyney Beekley,
Managing Editor and Advertising Manager

Robert S. Kruse,
Technical Editor

Harold P. Westman,
Assistant Technical Editor

David H. Houghton,
Circulation Manager

Subscription rate in United States and Possessions, Canada, and all countries in the American Postal Union, \$2.50 per year, postpaid. Single copies, 25 cents. Foreign countries not in American Postal Union, \$3.00 per year, postpaid. Remittances should be by international postal or express money order or bank draft negotiable in the U. S. and for an equivalent amount in U. S. funds.

Entered as second-class matter May 29, 1919, at the post office at Hartford, Connecticut, under the act of March 3, 1879. Acceptance for mailing at special rate of postage provided for in section 1103, Act of October 3, 1917, authorized September 9, 1922. Additional entry as second-class matter, acceptable at special rate of postage provided for above, at Springfield, Mass., authorized September 17, 1924.

Copyright 1927 by the American Radio Relay League, Inc. Title registered at United States Patent Office.
Member of the Radio Magazine Publishers' Association.

The American Radio Relay League

The American Radio Relay League, Inc., is a non-commercial association of radio amateurs, bonded for the promotion of interest in amateur radio communication and experimentation, for the relaying of messages by radio, for the advancement of the radio art and of the public welfare, for the representation of the radio amateur in legislative matters, and for the maintenance of fraternalism and a high standard of conduct.

It is an incorporated association without capital stock, chartered under the laws of Connecticut. Its affairs are governed by a Board of Directors, elected every two years by the general membership. The officers are elected or appointed by the Directors. The League is non-commercial and no one commercially engaged in the manufacture, sale or rental of radio apparatus is eligible to membership on its board.

"Of, by and for the amateur", it numbers within its ranks practically every worth-while amateur in the world and has a history of glorious achievement as the standard-bearer in amateur affairs.

Inquiries regarding membership are solicited. A bona fide interest in amateur radio is the only essential qualification; ownership of a transmitting station and knowledge of the code are not prerequisite. Correspondence should be addressed to the Secretary.

Directors

President
HIRAM PERCY MAXIM
Drawer 2102,
Hartford, Conn.

Vice-President
CHARLES H. STEWART
St. David's, Pa.

Canadian General Manager
A. H. K. RUSSELL
5 Mail Bldg.,
Toronto, Ont.

Atlantic Division
DR. EUGENE C. WOODRUFF
234 W. Fairmount Ave.,
State College, Pa.

Central Division
CLYDE E. DARR
137 Hill Ave., Highland Park,
Detroit, Mich.

Dakota Division
C. M. JANSKY, JR.
Dept. of Elec. Eng., U. of M.,
Minneapolis, Minn.

Delta Division
BENJ. F. PAINTER
424 Hamilton Nat'l Bank Bldg.,
Chattanooga, Tenn.

Hudson Division
DR. LAWRENCE J. DUNN
480 East 19th St.,
Brooklyn, N. Y.

Midwest Division
PORTER H. QUINBY
1034 Planters' Building,
St. Louis, Mo.

New England Division
DR. ELLIOTT A. WHITE
Dartmouth College
Hanover, N. H.

Northwestern Division
K. W. WEINGARTEN
3219 No. 24th St.,
Tacoma, Wash.

Pacific Division
ALLEN H. BABCOCK
65 Market St.,
Southern Pacific Co.,
San Francisco

Roanoke Division
W. TREDWAY GRAVELLY
Box 245,
Danville, Va.

Rocky Mountain Division
PAUL M. SEGAL
c/o District Attorney
West Side Court Bldg.,
Denver, Colo.

Southeastern Division
HARRY F. DOBBS
c/o Dobbs & Wey Co.,
Atlanta, Ga.

West Gulf Division
FRANK M. CORLETT
2515 Catherine St.,
Dallas, Tex.

Officers

President HIRAM PERCY MAXIM, Hartford, Conn.
Vice-President CHAS. H. STEWART, St. David's, Pa.
Secretary KENNETH B. WARNER, Hartford, Conn.
Treasurer ARTHUR A. HEBERT, Hartford, Conn.
Communications Manager F. EDWARD HANDY, Hartford, Conn.

Address General Correspondence to Executive Headquarters, Hartford, Conn.

EDITORIALS

IN December *QST* on this page, from the bottom of a heavy heart, we wrote a very black story of the very black outlook at the International Radiotelegraph Conference. It will now be apparent, from the article elsewhere in this issue, that the story of our impending demise was greatly exaggerated. The two accounts are not as much in conflict as might superficially appear, however. There was every justification for the December report; the outlook was at least that black; that we were unreasonably successful does not alter that fact. As this month's article relates, we have received international recognition to an extent that a month ago seemed altogether impossible of happening, and the combination of hard work, a few smiles from the Fates, and the loyal backing of the United States Delegation has produced privileges for us many times beyond what Europe wanted us to have and many times more than one could reasonably have expected from the situation which confronted us about midway thru the Conference. We succeeded beyond the wildest dreams to which we were entitled at that time.

At this writing, just at the close of the Conference, we are unable to state the official A.R.R.L. view of the Conference's provisions for amateurs. Official A.R.R.L. views are made only by our Board of Directors and our Executive Committee. To us at Headquarters, tho, it seems that these provisions offer us every assurance of a continued happy existence; and, in view of the many wild rumors which have been flitting about, it seems necessary that we say so.

The nations which ratify the Washington Convention are obliged to put it into effect by January 1, 1929. They may do so as much sooner than that as they desire, of course, provided such action does not conflict with the London Convention of 1912, which remains in effect, presumably, until that date. It is to be imagined that during the coming year our Federal Radio Commission will not make any assignments or regulations that will be found to conflict after the first of 1929 with the Washington Convention. We sincerely trust, tho, that they will permit the amateur regulations of the United States to remain in status quo thru-out the year 1928, to give us the maximum time to contemplate the new situations which will confront us and to permit the amateur societies of the world ample time

to make their plans for the new order of international coöperation which will then be essential.

DURING the past month the members of the A.R.R.L. Experimenters' Section and the operators of A.R.R.L. Official Relay Stations have been requested by the Federal Radio Commission to conduct a survey of broadcast-reception conditions in their respective towns, particularly from the standpoint of heterodyne interference. The Commission wanted skilled observers, and neutral ones.

We are proud of this opportunity to assist the Commission. It is an honor. It is likewise another example, for the world to see, of the utilitarian value of the American amateur.

TROUBLE comes in bunches. The international conference was not yet over when we were informed that the Federal Radio Commission was again experiencing a flood of complaints against interference to broadcast reception by amateurs. The situation is very serious. We do not know whether the trouble comes from increased listener-interest at the return of cold weather, or increased amateur activity for the same reason, but there is no doubt of the increase of complaints. So serious is the situation that we are informed that the Commission is contemplating an extension of amateur quiet hours, when they are imposed, to six o'clock to midnight. This will be about as bad as sudden death to the amateur who experiences it.

And so we are again waving the old Rettysnitch and we here and now call upon every amateur to take stock of his station and clean house. Do you interfere with your neighbors? If you do, you are very liable to have quiet hours from 6 to 12 hung upon you. It seems up to us, individually, and for our individual preservation, to take the necessary steps to avoid any such interference. If you don't know whether you interfere or not, it is really up to you to find out by inquiry, and to remedy it if interference is occurring. Practically every case of BCL interference can be cured easily. It's an annoying job, we know, but it seems that each one of us had better tackle it. If there's trouble, take a look at the affected BCL set. Perhaps it's obsolete, or too tightly coupled to the antenna, or with too long an antenna. Probably the

trouble can be cured completely with a simple trap made from parts in the junk-pile.

But it may be the transmitter itself. Most amateur transmitters are too tightly coupled to the antenna—too tight for best communicating efficiency as well as too tight from the standpoint of causing interference. There is no single thing that may be done to an amateur transmitter which will so effectively decrease its interference as to loosen up the coupling. Most of the trouble in amateur stations comes from the keying, either from the actual impact of keying or from the wobbling of the wave as the power goes on and off. Loosening the coupling helps these things a lot. But key filters or other devices minimize the effect of keying upon neighboring antennas are often necessary in addition. There can be no dearth of data on these things—QST has had worlds of material on them; so has the Handbook. And in particular all the ills to which an amateur station is heir can be detected right at the station by the use of a monitor-box such as described on page 24 of our July issue. Every amateur station ought to have such a device and use it frequently to check the quality of the station output. It will quickly show up troubles and indicate what ought to be done about it, as is explained in the article referred to.

There is really little or no excuse for interference to-day with modern-day BCLs. And the Commission is not sharing as wholeheartedly as it used to the view that if an amateur station complies with all the specifications of its license and still interferes, it is the listener's hard luck. Next to the I.R.C. story, the chief news of this month is the tip that every amateur owes it to himself to investigate and clear up any interferences from his station, or we won't be able to stop this 6-12 business.

IN February the A.R.R.L. Board of Directors will meet in its annual session, to formulate the League policies for another year and to instruct the officers how to carry out these policies. This Board is composed of Directors whose names and addresses appear just before the editorial page in every issue of QST. There is a director from each A.R.R.L. division in this country, and one from Canada. In the determination of A.R.R.L. policies these directors speak for their respective territories. Members having views to express on A.R.R.L. policies should communicate them now to their respective Directors, in preparation for this meeting.

WITH the International Radiotelegraph Conference safely behind us, we have five years in which to speculate upon what will happen to us at

the next conference and in which to ponder upon the motives behind the attitude of the European nations this year. The general purpose of that attitude was to come as close as possible to abolishing amateur radio, particularly international amateur contact. That this was not done is attributable to the very fine support given to the amateur cause by those liberally-disposed administrations which have encouraged amateur radio and have found it, as it indubitably is, a great national asset. The European arguments against the amateur were numerous, diverse—and, for the most part, fallacious. It is interesting to examine them. During the eight weeks of the conference I cataloged the following:

1) Fear that amateurs will violate the state monopoly on communications, thus depriving the state of revenue. Fear that a regulation prohibiting this violation would not suffice, that the very number of amateurs makes it impossible to police them adequately in this respect, and that the only safe control is to do away with them or make their operations so difficult technically as to prevent them from accomplishing much.

2) The general denial of the right of any group to participate in communication other than governments and authorized commercial systems. Europe does not permit private enterprise to engage in communication, as is exemplified in this country not only by amateurs but by our limited commercial services, and it is an age-old policy to attempt to deny this privilege.

3) Fear of a general lack of control of amateurs, not only as to the nature of their communications as mentioned in the first item but with respect to technical features of their operating, and particularly a fear that they will cause interference with other services.

4) The general selfish desire of government and commercial interests to retain for themselves all useful wavelengths, and an unwillingness to allow privileges for non-government or non-commercial purposes. The value of an established international communicating service on a single short-wave channel, based on its potential earning power, might be said to be a million dollars. Why give away hundreds of such channels to amateurs, who merely play and never really discover anything? One such commercial service is worth more than 25,000 amateurs. This attitude was beautifully summarized by the gentleman who represented Canada in the frequency allocations when he said that he did not think that amateurs should ever be given any wavelengths that are known to be useful for any commercial or government communication, and that he thought they

should always be obliged to stay within territory which was regarded as completely useless for any commercial or government communication.

5) The delicate business of war talk. The astounding impression, based upon the fact that the technical representatives of the United States Delegation who spoke for that delegation in upholding the amateur were Army and Navy officers, that the American amateur is primarily an auxiliary of the armed forces of the United States—and therefore to be discouraged.

6) Hysterical fear that the needs of new services in the short-wave field, such as shipping, aircraft, navies, etc., were about to create so great a congestion that it was impossible to spare any waves to amateurs even if it were thought otherwise desirable to do so.

7) Fear that amateur licenses might be granted to unscrupulous persons who would use such stations to undermine the security of the state, as by fostering revolution, spreading Red propaganda, etc. It is to be remembered that when amateur stations are permitted in such countries they are the only agencies of communication in the whole country which are not under the direct and absolute control of the state, particularly as regards censorship. There is hardly a government in Europe so stable that it does not have to take account of these possibilities.

8) General unwillingness to be bothered

by something that would make additional administrative work. The feeling that the United States Government is little short of insane in having encouraged amateur radio, and determination to avoid taking on that administrative work themselves.

9) Fear of the political power of amateurs if permitted to grow to large numbers. Being completely unable to comprehend that our own Government can and sincerely does regard us as a national asset, Europe has the idea that American amateurs must be forcing their Government to support them through political pressure and the power of their votes—and so the resolution to avoid that in their countries.

It should be perfectly apparent to any informed North American amateur that the long experience of the governments of the United States and Canada, obtained in not only freely permitting but actually fostering amateur radio in this continent since the first days of wireless, offers abundant proof of the fallacy of these arguments. Fortunately the unfriendly European administrators of radio have in many cases returned home with greatly softened views of amateur radio, based upon a much better acquaintance with its nature than they ever had before. But these arguments open to view in some measures the difficulties that confronted the amateur representatives at Washington.

K. B. W.

Election Results

NOMINATIONS in the biennial elections for Director in six A.R.R.L. divisions were examined by the Executive Committee on November 1st. In three of the divisions there was but one candidate and as a result, in accordance with our By-Laws, the following Directors have been declared re-elected to succeed themselves, for two-year terms which commence on January 1, 1928:

Dr. E. C. Woodruff, Atlantic Division
 Prof. C. M. Jansky, Jr., Dakota Division
 Mr. Benj. F. Painter, Delta Division

Mr. A. H. Keith Russell had no competitor as nominee for Canadian General Manager, and has similarly been declared re-elected for a two-year term.

In the Pacific Division Mr. A. H. Babcock, the incumbent, and Lt. Col. Clair Foster were nominated. Col. Foster withdrew his

name, leaving Mr. Babcock as the only nominee, and the latter was similarly declared re-elected for 1928-29 without balloting by the membership.

In the Midwest Division three candidates were nominated: Mr. Porter H. Quinby, the incumbent, and Messrs Ray E. Bolin and Frank J. Sadilek. The result, as ascertained by the Executive Committee on December 2nd, was as follows:

Mr. Quinby	213 votes
Mr. Bolin	194 votes
Mr. Sadilek	55 votes

Mr. Quinby has therefore been declared re-elected for 1928-29.

In the Southeastern Division no nominations were made and there is consequently no election. In accordance with the Constitution, Director Harry F. Dobbs remains in office until provision is made for a new election.

K. B. W.

A General Purpose Device

A Combined 15-to 2500-Meter Portable Receiver, Audio and Radio Oscillator, Amplifier and Wavemeter

By Howard Allan Chinn*

FOR those who for one reason or another find it necessary or convenient to be able to move the receiver around easily and for the man who wishes to get the most possible use from his limited supply of apparatus the set described in this article may be of interest. While it is fundamentally a plug-in coil receiver of the usual circuit arrangement the small set shown herewith will be found useful around the amateur laboratory for many purposes. The panel size is only $6\frac{1}{2} \times 8$ inches, the cabinet depth 5 inches and besides providing a receiver covering all the wavelengths from 15 to 2500 meters (20,000 to 120 kilocycles) the set will be

capacity for short wave reception (below 200 meters) or both sections of 400 μfd . maximum for the longer waves. The small section consists of three rotor and four stator plates, the rotor plates being cut (originally semi-circular, straight capacity line plates) to give approximately straight frequency line tuning for the first 70 of the 100 dial divisions. The plates were cut this shape merely for convenience in tuning the higher frequencies, the plates in the large section of the condenser being unaltered. Figure 2 shows the resulting shape of the plate. If one uses the usual straight capacity line plates only two rotor and three stator plates, arranged so that there are three active dielectric spaces, will be necessary to obtain the maximum capacity of 65 μfd . The small section of the condenser provided a tuning range of about $1\frac{1}{2}$ to 1. That is to say, if the set tunes to 30 meters with a particular coil with the tuning condenser at a minimum capacity the maximum wave reached with that particular coil will be 45 meters. For the two sections combined a tuning range ratio of 3 to 1 is obtained.

A miniature single-pole single-throw switch is mounted on the side of the dual section condenser (directly on the stator terminals) to provide selection of one or both sections. It is arranged with the switch arm connected to the large section and the switch jaw connected to the small section thus providing the minimum amount of extra hardware tied to the section of the tuning condenser that is used for the short wave reception. A National vernier dial is used for the tuning control, while the particular throttle condenser used was provided with a geared vernier control.

The radio frequency choke r.f.c. is a Samson helical wound choke and has been found very satisfactory on all the waves which the set covers. The use of a choke wound in this manner is strongly recommended in preference to the ordinary layer wound affair in a receiver of this nature where it is essential that the choke operate properly over a very wide band of frequencies. Because of the construction of these chokes there is no pronounced resonance point and therefore no critical region within which the coils give non-uniform or undesired results.

The amplifying transformer used is a high grade broadcast transformer (de-

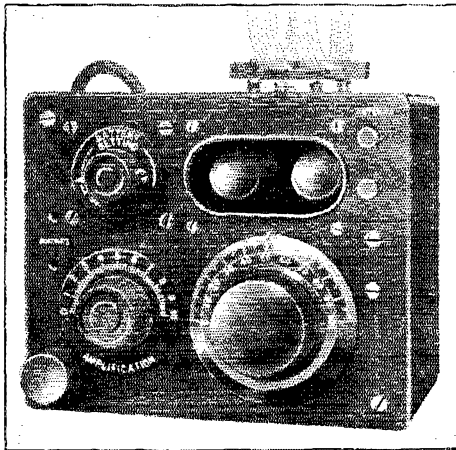

EXTERNAL VIEW OF THE DEVICE

found handy for use as a heterodyne oscillator or wavemeter, as an audio oscillator, as a variable condenser unit or as an additional stage of audio amplification for an external set-up.

The photographs show the general panel layout and Figure 1 gives the circuit diagram together with the constants of the various pieces of apparatus. A two section Cardwell condenser is used for secondary tuning and is arranged to permit the use of one section of 65 μfd . maximum ca-

*Electrical Communication Laboratory, Massachusetts Institute of Technology, Cambridge, Mass. This article is a contribution from the Col. E. H. R. Green Radio Research.

signed for broadcast reception) but one whose physical dimensions were such as to permit its being incorporated in a set of this limited size. The use of a good transformer is desirable because of the high amplification obtained on *all kinds* of amateur signals and the good quality broadcast reception that results.

To protect the tubes from mechanical injury and to reduce tube noises to a minimum, spring sockets were used. It is also advantageous to provide a means for damping the vibration of the detector tube, as for instance by stuffing some of the felt, the tubes are wrapped in when bought, around the detector. UX sockets are handy, in that, they permit the use of the different types of tubes that are now available with UX bases. A 50-ohm rheostat is used to permit the use of any battery from 3 to 6 volts with either one or two tubes (of any of the usual types) in the sockets. Battery connections are taken care of by means of a flexible multi-conductor cable. This was found to be more

actually used are shown in one of the photographs. The Samson coil forms will be found handy for those who wish to make a bank winding for the longer wave coils (above 1000 meters) because of the ends provided on the forms which gives one something to wind "against" and does away with the unpleasant slipping of the first turn which one experiences when attempting a bank winding in ordinary tubing.

WAVEMETER AND SIMILAR WORK

A coil plug strip with binding posts or Fahnestock clips it may be used in place of the usual coil and by removing the tubes from the sockets we may connect to the secondary terminals and thereby obtain the

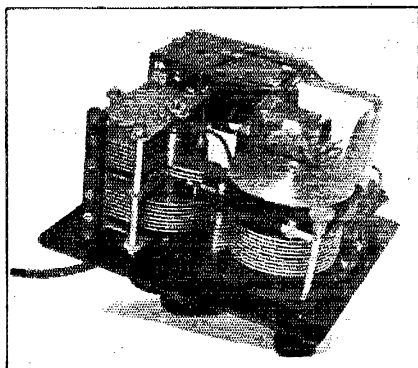

THE ARRANGEMENT OF THE PARTS

Note in particular the trimmed rotor plates of the two-section variable condenser.

convenient than fussing with connecting wires each time the receiver was set up.

Phone tip jacks are used since they permit a quick and easy way of connecting the phones to the circuit and do not require a large amount of space back of the panel.

The coil system is one that has been described many times in *QST* and has the desirable feature that the coils may be plugged in either way without affecting the operation of the set in the least. The plug spacing is the same as that found on the General Radio coil forms. The outside plugs and jacks (grid and filament) are spaced 1 15/16" and the inner plugs (plate and B plus) are 3/4" apart. All manners of coils and coil forms may be mounted on the plug strip. Some of those which were

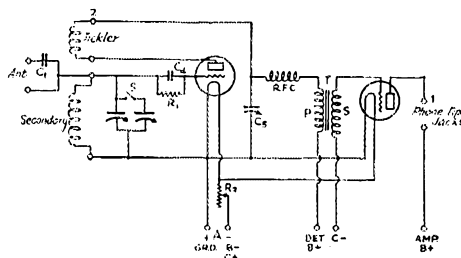

FIG. 1. THE CIRCUIT

- C1 Antenna coupling condenser. Two plates 1 1/2" square, separated 1/8".
- C2 Secondary tuning condenser. Small section of Cardwell dual condenser. 65 μfd. maximum.
- C3 Secondary tuning condenser. Large section of Cardwell dual condenser. 335 μfd. maximum.
- C4 Sangamo grid condenser. 100 μfd.
- C5 Throttling grid condenser. 500 μfd. maximum.
- R1 Grid leak. 5 to 10 megohms.
- R2 Filament Rheostat. 50 ohms.
- RFC Samson type 125 radio frequency choke
- T Samson symphonix transformer.

use of the secondary condenser for an external circuit arrangement we may be working with. Also, by connecting to the proper terminals the throttle condenser can be used in other circuits. There is no reason why either one or both of these condensers cannot be calibrated so as to furnish

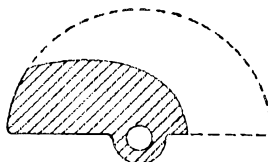

FIG. 2. SHAPE OF THE TRIMMED ROTOR PLATES

a calibrated condenser unit for laboratory work that does not require too great precision.

It is also possible to plug-in a single coil across either one of the variable con-

densers and provide an ordinary wavemeter which is not much larger than the usual one found around amateur "shacks" and one whose calibration will probably hold as well as most of those in said shacks.

If one prefers the heterodyne wavemeter the usual coils may be plugged-in and with the throttle condenser set at a given point to obtain good oscillation the set may be calibrated and it will be found that its calibration will hold quite well (Within 1% or 2%). A heterodyne with a rough calibration of this nature will often be found very handy around the amateur laboratory.

AS AN AUDIO AMPLIFIER

If an additional stage of amplification is needed for some purpose or other one merely plug-in the binding post strip, places the amplifier tube in the socket, connects

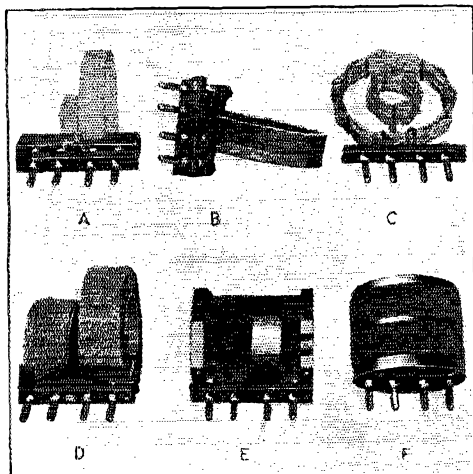

TYPICAL TUNED-COIL-AND-TICKLER COMBINATIONS

No dimensions need be given since everyone can easily make coils to meet his own requirements.

A—A home-made space-wound coil combination.
B—A Coil-combination based on the Hammarlund celluloid-supported windings.

C—Lorenz or basket weave coils.

D—Honeycomb coils for long waves.

E—Coils on a Samson coil form for intermediate wavelengths, the same forms also being suited to long-wave banded windings.

F—Single-layer windings on a General Radio bakelite form.

to the proper terminals and uses the last tube and its associated apparatus, thereby obtaining one stage of good transformer coupled amplification.

AS AN AUDIO OSCILLATOR

To use the set as an audio oscillator, the detector tube is removed from the socket, terminal No. 1 of Figure 1 is connected to terminal No. 2 and the detector B plus lead

disconnected from the B battery and connected to the phone tip removed from terminal No. 1. The wave form of the resulting oscillation is, of course, far from sinusoidal but the thing will oscillate at an audio frequency and a source of noise is often useful. The frequency can be varied to some extent by adjustment of the throttle condenser (it now being a tuning condenser) or by variation of the plate

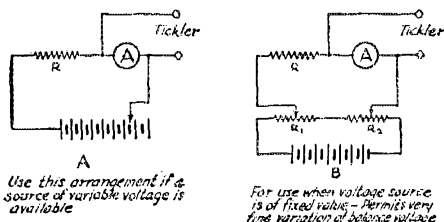

FIG. 3. THE SET AS A VACUUM-TUBE VOLT-METER

A—Low reading milliammeter—not larger than 0-1 mil.

R—Resistance 5 to 10 times meter resistance.

R1—200 w potentiometer for coarse control

R2—2 w potentiometer for fine control

resistance of the tube which can most easily be accomplished by varying the filament temperature. It has been found that the tube usually must be run at a very low filament voltage to obtain oscillation in the order of 1000 cycles with the particular transformer used in this set.

Binding posts are provided on the panel for the antenna connection which may be to the grid through the small coupling condenser, directly to the grid or through any capacity that may be inserted in series with the antenna external to the set. Direct connection to the grid is sometimes necessary for certain laboratory work and it was therefore thought desirable to provide the additional binding posts, which, incidentally, permits even the small coupling condenser to be used for other purposes. The ground is connected to the A battery plus terminal.

By connecting the proper apparatus (meter, balancing resistances and batteries) as shown in Figure 3 between the tickler binding posts we have a vacuum tube voltmeter of the grid detection type. The uses of an instrument of this type in the laboratory are innumerable and need not be mentioned here. If one uses the set as shown as a thermionic voltmeter and wishes to measure the voltage across an open circuit (as far as d.c. is concerned) it will be necessary that the circuit be arranged so that the grid leak goes from grid to filament instead of across the grid condenser as shown in Figure 1. This change can be incorporated in the original circuit without affecting the operation of the set as a receiver.

The Amateur and the International Radiotelegraph Conference

By K. B. Warner, Secretary, A.R.R.L. and I.A.R.U.

THE International Radiotelegraph Conference is over! The Washington Convention of 1927, signed on November 25th, attests the eight weeks of strenuous work of 200 delegates, 178 special representatives, and uncounted functionaries, attachés and clerks, representing 55 countries and 23 dominions and colonies. The London Convention of 1912 is no more—a new order prevails. In it, for the first time, the radio amateur receives an international status and recognition as a factor in radio, the rules governing his conduct are set forth, and his rights and privileges are defined. Those privileges in most respects are entirely adequate. We have achieved a great victory.

It is extremely difficult to compress within the confines of a single magazine article an accurate account of the eight busiest and most anxious weeks of one's life, weeks when the ultimate fate of the amateur hung momentarily by a thread. I do not know where to begin. I have written much about this conference in my editorials of the past several months, not only because it was the most important news of the day but also because it was a subject that had been occupying me almost exclusively during those months and I knew more about it than anything else. In those editorials I have attempted to depict the gradual unveiling of the Washington picture, and I ask our readers to accept them as the background for this account and let me go on from there.

Vice-President Charles H. Stewart and I were in attendance during the entire eight weeks of this conference. We didn't miss

a day. We were joined at critical times by Mr. Maxim, president of the League and of the Union, under whose leadership we worked. We were gloriously backed and represented by the American Delegation and valiantly assisted from time to time by delegates from Canada, Italy, Australia and

New Zealand. Most of the rest of the world was against us. Even Canada, thru no fault of the estimable Commander Edwards, was against us when it came to wavebands—of which more anon.

I have previously described how the conference was divided into committees. Some matters affecting the amateur arose in most of the committees but most of our matters were centered in the Technical Committee, presided over by the renowned and beloved General Ferrié of France. This committee had three sub-committees, presided over respectively by Professor A. E. Kennelly of Harvard, of Kennelly-Heaviside Layer

fame and a former A.R.R.L. Director; Mr. E. H. Shaughnessy, assistant chief engineer of the British Post Office; and Professor G. Vanni of Rome, who amongst other titles is president of the Italian Section of the I.A.R.U. The amateur matter first arose in Mr. Shaughnessy's sub-committee when Great Britain's proposal for amateurs was reached for examination, and the battle was on when Japan led off with the devilishly ingenious suggestion that all transmitting amateurs be obliged to use phantom antennas. Mr. W. D. Terrell, Chief of the Radio Division of the Department of Commerce, stemmed the tide with a splendid address on behalf of the amateur, and served the first notice that the American Delegation

Highlights

Recognition of amateur radio.

Amateur bands near 160, 80, 40, 20, 10 and 5 meters.

Amateurs of every country in the same bands.

Ample bands for domestic work, ample for experimentation, probably enough for DX day work, uncomfortably restricted band for international night work.

Power of amateur stations fixed by each nation.

Each nation free to permit or prohibit amateurs as it desires; each nation free to withhold from amateurs any or all of the bands.

International amateur message traffic forbidden except by special arrangements between nations.

New system of amateur calls to indicate nationality, restoring intermediate "de" and abandoning "international intermediates".

Convention effective January 1, 1929.

tion was expecting its amateurs to get a fair shake. And so a sub-sub-committee on the amateur was appointed, consisting of eleven members with Professor Mesny of France as its chairman. Thru the kind efforts of the American Delegation I was made a member of this sub-committee, as a representative of the amateur.

It is necessary to pause here and say that the preservation of amateur radio on the face of the earth to-day is very largely attributable to the efforts of the United States Delegation. Amateurs in every country of the world are indebted to them for their preservation. There were liberally-minded representatives from other countries, most notably Captain Montefinale of Italy, Commander Edwards of Canada, Mr. Brown from Australia and Mr. Gibbs from New Zealand, and of course the amateur representatives were doing their very best. But all of us would have been sunk if it had not been for the American Delegation. Our people served notice from the first that they would demand that the amateur be cared for. At first the opposition was equally insistent but gradually it wore down a bit, and the eventual result, as in all such things, was a compromise. But for one reason or another, chiefly the economic demand for international waves and the fear that the activities of amateurs in various directions couldn't be controlled, the bulk of the world was bitterly opposed to us. I shall say something on the editorial page this month about these reasons. This seems the proper place, too, to retract the hymns of praise we sang in a recent editorial about the remarkable friendliness and openmindedness of the British Delegation, as judged from a first impression at Ottawa. We regret that we must alter our opinion of them. The leaders of the opposition, they were the amateur's most bitter opponent, and unremittently and relentlessly they pursued us and hacked at us in every committee. The British are said to be the best negotiators on earth. We presume that from their standpoint they may feel that they did a good job at Washington. For our part, we offer our apologies to the British amateurs for our inference that they didn't know their officials.

And now to get back to that sub-sub-committee on amateurs. It met the next day, and Messrs. Terrell, Edwards, Brown and Gibbs spoke, as delegates from their respective countries, on behalf of the amateur. It was evident that there were going to have to be amateurs. The British delegate at this meeting was Mr. F. W. Phillips, assistant secretary of the G.P.O. Mr. Phillips believed in amateurs too—had they not 1200 of them in England? But of course the amateurs would have to expect to be restricted to narrow territory. Mr. Phillips had a little paper all ready, as it seemed every British delegate always did, and he

thereupon proposed that amateurs be assigned a band in the vicinity of 150 meters and not more than six narrow bands, distributed thruout the short-wave spectrum in harmonic relation and located, for example, at 109.33, 82.00, 54.66, 27.33, 13.66 and 6.83 meters. These unusual figures are, with the exception of the 32-meter wave, harmonics of 2750 kc. They were no strangers to us, for we knew that the British had a scheme for the division of short waves which provided a boundary between mobile and point-to-point services at 11 megacycles (about 27 meters) and that, using this as a starting point and working in both directions, they had arrived at this set of figures for us. We had other ideas, but this *petite comité* could do no actual allocating—it was merely making a recommendation, and of course we were in sympathy with the idea of harmonically-related short-wave bands thruout the spectrum and this was but an example. The argument then hinged on the word "narrow". The friends of the amateur did not want that restriction, as this committee at best was but recommending, but Mr. Phillips (and he was not alone in it) stuck out for "narrow", offering at one time to replace the term "narrow bands" with "bands not over 100 kc. wide". Finally, by a vote of 6 to 5, the word "narrow" was retained. The meeting then decided to recommend that each nation remain free to determine the power of amateur stations; that amateur stations be under the obligation of keeping their waves within their assigned bands, stable, and free from harmonics; and that they sign their calls frequently. When the meeting adjourned it was freely predicted that we amateurs would eventually get 100-kc. bands at the British figures, and nothing more.

This amateur report was accepted by Mr. Shaughnessy's sub-committee and eventually by the whole committee under General Ferrié, and from there the recommendation for amateur waves went to the consideration of Professor Kennelly's sub-committee, which dealt chiefly with the allocation of wave-bands. There a considerable delay ensued, for that committee was then working on the allocation of waves down to 200 meters, in which we did not figure, and it was some weeks before the short waves were agreed to.

In the meantime the question of the nature of communications to be permitted amateurs came up in the Committee on General Regulations, where the chief United States representative was the Hon. Wallace H. White, jr., Congressman from Maine, father of the numerous White radio bills, and our friend for years. In practically every country outside of North America, the governments own and maintain all of the communication systems as a state monopoly, and they were all very insistent that this monopoly be protected against in-

fringement by amateur messages. Many countries had made proposals about this, some of them amazingly drastic. France formulated a compromise between the proposals of Germany Great Britain and Switzerland which would confine amateur signals in every country to those relating to experiments under way and prohibit code, secret language, commercial language, "personal or actual information", or information for a third party. This was ter-

tween private experimental stations of different countries is forbidden, if the administration of one of the interested countries has given notice of its opposition to this exchange. When this exchange is permitted the communications must, unless the interested countries have entered into other arrangements among themselves, be effected in plain language and limited to messages bearing upon the experiments and to remarks of a personal character for which, by

AMATEUR FREQUENCY BANDS *assigned by The Washington Convention of 1927*

Kilocycles	Width in Kilocycles	Assignment	Approx. Meters on basis factor 3	Meters on basis factor 2.998	Harmonic family for centers of related portions		Amateur Purpose
					Kilocycles	Meters	
1715-2000	285	<i>Amateur, Mobile, point-to-point</i>	150 - 175	149.9 - 174.8	1775	168.92	<i>Domestic</i>
3500-4000	500	" "	75 - 85.7	74.96 - 85.66	3550	84.46	"
7000-7300	300	<i>Amateur Exclusively</i>	41.1 - 42.9	41.07 - 42.83	7100	42.23	<i>International Night</i>
14,000-14,400	400	" "	20.83 - 21.43	20.82 - 21.42	14,200	21.11	<i>International Day</i>
28,000-30,000	2000	<i>Amateur & Experimental</i>	10.00 - 10.71	9.99 - 10.71	28,400	10.56	<i>Experimental</i>
56,000-60,000	4000	" "	5.00 - 5.36	4.997 - 5.354	56,800	5.28	"

rible. This was an international conference and its findings should not concern the domestic policies of any country; a country should be free to permit her amateurs to handle messages internally if she wishes; even internationally if both countries agree. It looked like the rest of the world wanted to prohibit our American amateur traffic just because they didn't want their amateurs to handle messages. We rushed to Mr. White; he was already looking for us, to help. The British had a less obnoxious counter-proposal—they felt that the French proposal went too far, altho why we don't know. We seized upon the British compromise as a basis, but this text forbade any international messages under any circumstances and even international contact between amateurs if one of the countries concerned should object. Mr. White negotiated a further compromise for us, and by the next meeting had the agreement of the British, French and Germans. At that meeting he made a fine and able plea for the amateur and eventually we had the pleasure of seeing the compromise text adopted. Without his assistance we would again have been sunk, with useful message-traffic absolutely denied us. When the text finally came out of the Drafting Committee it read as follows:

"The exchange of communications be-

reason of their unimportance, recourse to the public telegraphic service might not be a consideration."

If this sounds hard, consider what it avoids! It is cruel to hear talk of an administration denying its amateurs the right to communicate internationally, but of course that has always been a nation's privilege if it wanted to exercise it. As to the necessity for special arrangements between countries before international traffic is permitted us, we've never had any particular international traffic except with Canada, and that we feel sure can be arranged. The amateurs of other countries have been prohibited from message handling anyway—which is possibly proper enough in the case of actual messages whose handling actually denies revenue to the state—and so they lose nothing. The general freedom of action allowed under this provision I find quite gratifying, and certainly infinitely superior to the original proposal which would prohibit every amateur from saying anything in the way of "personal or actual information".

And now let us return to our wavelengths, where the real story remains to be told. The sub-committee on allocations was an unwieldy body. Its work was of vital importance to everybody, so its meet-

ings were attended by the delegates of 78 nations and the representatives of a hundred special interests. It had to conduct its business formally, with recognition from the chairman, interpretation of remarks into French or English, and its minutes had to be kept carefully, paralyzing free speech. In the case of the long waves, then, it was early recognized as hopeless to attempt an agreement in so large a body, and so the committee adjourned while the various delegations attempted to get together and agree informally on a tentative program to be set up as a basis for discussion. Specially-trusted representatives of the bigger powers met each other informally and discussed wave-lengths, over the afternoon tea-cups or in hotel rooms at night. Gradually the "tea-cuppers", as they came to be called, found themselves approaching an agreement. Then two of them would meet the representative of another country, reach an agreement that the three of them could accept, and so progress to the point of taking in a few more countries, until eventually a tentative agreement had been reached between the eight or ten leading powers. This had all been done entirely informally, outside the actual conference, without official commitments, with no records kept and with everybody therefore able to speak freely. Ten days or so were thus consumed, and then the sub-committee reconvened and received the suggestions. By that time it had the endorsement of the leading countries and provided an admirable basis for discussion, being of course altered in the process of discussion but eventually being adopted closely as negotiated over the tea-cups.

When all the waves down to 200 meters had been decided upon it was determined to employ the same method for a preliminary

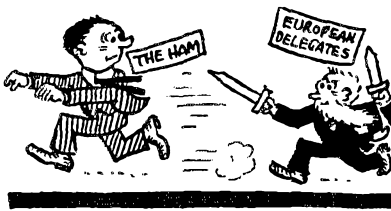

agreement on the short-waves, and the sub-committee again adjourned to await a recommendation. Our anxiety then can be imagined. We had seen the long-wave agreement negotiated informally, the only possible way but with many people unable to participate in the original formulation, and we had seen that plan subsequently adopted with little alteration. The short-wave problem was admittedly much more difficult, so difficult that the possibility existed that there would be no agreement at

all. But if one were eventually secured, what chance would there be to get alterations in it if we didn't like it? About zero, we figured. It was therefore a tremendous relief when I was personally invited to participate in the short-wave discussions, to represent the amateurs.

Altho elated that I was to be a tea-cupper myself, we had our grief even then, for they informed us that the room where the get-togethers were to be held was so small that there was room for but one amateur representative. And so we had to break up the old Stewart-Warner firm and I went alone. I cannot tell you amateurs of my emotions as I sat for days in those meetings, the only amateur representative. I felt that my responsibility was a very heavy one. The fate of the amateur world rested largely on how I conducted myself. I had loyal friends in the United States representatives present, and an occasional one from another country, but the rest of the world was frankly against me. Would I be able to put it over, even with all the help of powerful friends? Would I be able to tell our story convincingly enough to get our modest requests from an assemblage which was determined not to give it to me? I had no one with whom to consult during the meetings; I could only keep my wits about me and do my best. But between meetings Mr. Stewart and I had long sessions of our own, analyzing the work to date and altering our plans as the situation changed, and then I would go back to another meeting to carry on.

It is necessary here to digress a moment to explain the informal American organization which represented this country in these wave-length discussions. All technical matters of the American delegation were under the direction of Major General Charles McK. Saltzman, Chief Signal Officer of the Army. General Saltzman is a loyal friend of the amateur, and he proved it thruout the conference. Amongst the technical advisers attached to his staff for the conference were Lieutenant Colonel Joseph O. Mauborgne, for the last several years in charge of research and development for the Signal Corps but now on duty at the Chief's Office; Captain S. C. Hooper, in charge of the Radio Section of the Bureau of Engineering, U. S. Navy; and Lieutenant Commander T. A. M. Craven, U. S. N., who was recalled from sea for duty at the conference on behalf of the Navy Department because of a previously demonstrated peculiar aptitude for this kind of work. These three technical advisers represented the United States in the wave-length negotiations. There was the real meat of the whole problem, and there was where their insistence on behalf of their Government that amateurs be provided for was really effective. We amateurs have much for which to be grateful to them, for they saved the day for us. Captain Hooper

presided at all the informal meetings of the "tea-cuppers". Commander Craven conducted the actual negotiations. In fact, the structure of wave-length allocations finally arrived at is largely his handiwork. This young Naval officer has made an enduring name for himself. It may be said that he is personally responsible for the successful negotiating of the wave-length agreements embodied in the Washington Convention of 1927. What a monument to have to one's credit! The conference has praised him for it. I sing his praises too, for he was the staunch and clever friend of the amateur and in large measure we owe what we got from the conference to his skill and perseverance. These three officers let no opportunity go by to stand up for us. If we did not get all we want, it only shows the difficulty of the task and how hopeless we would have been without their help. I want to tell you amateurs that our friendly bonds with the Army and Navy have paid the richest possible dividends!

But I must get on with the tea-cupping. It was a most difficult task. There were about twenty-five people present at most of the meetings, representing eight leading countries and a number of special interests. Six meetings were held, stretching over eight days. Gradually an agreement began to take form. There were endless arguments between mobile and point-to-point, conflicts with expensive beam stations, and what not. It was really very difficult and only a splendid effort to secure agreement by mutual compromise made the result possible. Amateurs were left out while the preliminary chopping between mobile and point-to-point was made, but with pointed insistence by the U. S. delegates that the meeting should return later and fit the amateur into the picture. I was on needles and pins for days, watching this part of the program in which I did not participate, inwardly pulling for a division which would put point-to-point bands at the places where I wanted to see amateur bands. The United States wanted the same thing, and eventually the division was made along lines that made that possible. In the meanwhile the upper amateur band, to be "in the vicinity of 150 meters", was located as from 150 to 175 meters. Higher territory seemed impossible; it had already been determined to give 175 to 200 to mobile exclusively, when the long waves were discussed; I didn't much care; that seemed ample for our needs in an upper band, even if it were non-exclusive (as indeed it already is in this country). Besides, I was holding my fire for the short waves.

At last they got thru the table, down to 13 meters. Then they started on some narrow bands for short-wave broadcasting but couldn't agree and decided to leave that for a still smaller group to discuss. At last

the amateur question! I took another reef in my belt and prepared for action.

Mr. Shaughnessy led off. The table as agreed at that time provided certain exclusive bands for point-to-point, some more exclusive bands for mobile, and some narrow shared bands. His proposal was that the amateurs share a small part of the already shared bands. I had horrible visions of a senseless selection of amateur bands without harmonic relation and filled with mobile interference. Some days previous we had prepared and circulated a paper containing a suggestion for the amateur bands, proposing that they be centered at 20, 40, 80 and 160 meters as locations where our operations of the last several years had undoubtedly served to keep them clearer of established commercial services than any other locations; and, instead of "narrow" exclusive bands, urging moderately wide "N.G.P." bands, that is, bands reserved for stations not open to general public correspondence, such as government stations, amateurs, etc., from which bands amateur stations might be provided. The idea was that this would provide sufficient flexibility to make wider bands possible in countries having many amateurs, yet leaving a nation free to assign her amateurs but small bands if the number of amateurs was small or the administration hard-boiled. I countered Mr. Shaughnessy with this proposal, and Commander Craven backed me up with the request from the U. S. Delegation for more definite amateur bands. But nobody else liked the N.G.P. idea, it seemed. The situation instantly was serious, for with this idea of flexibility lost we would be confronted with fixed bands which would inevitably be narrow—the maximum to which international assent could be got. Then Captain Gino Montefinale, of the Royal Italian Navy, the commandant at IDO, proposed a counter scheme, suggesting amateur bands centered at my figures and of variable width, as each administration desired, but not exceeding certain maxima, and these maxima were the same as the proposed widths of my N.G.P. bands. Captain Montefinale was a fine friend of the amateurs thruout these meetings, and in fact absolutely the only one we had outside of the American delegation, for even Canada worked steadfastly against us for all her delegate was worth. The amateurs of Rome should give Captain Montefinale a dinner—his assistance was most appreciated. But nearly everybody objected to his scheme the same as they had to mine, and the battle waged on thru anxious moments. France would accept if the bands avoided the mobile waves. Mr. Shaughnessy objected that our proposed waves would hit into the center of the point-to-point bands and again demanded that amateurs be in the shared bands, with talk of 800 kc. total for us, in which he was supported by Germany. I objected again,

backed this time by all the mobile people, including the U. S. and Japanese navies. And finally we sold them on 20-40-80! I thought that tremendously important, not because those were our American waves but because our occupancy of them had made them much less likely to conflict with established commercial services than any other locations one might have named—and future events showed I was dead right in that. Mr. Shaughnessy would agree if the amateur bands were narrow as the sub-sub-committee had recommended, and came from the edges of those point-to-point bands, and he proposed 400 kc. near 18 $\frac{3}{4}$ meters, 200 kc. near 37 $\frac{1}{2}$, and 100 kc. near 75. This was a tremendous concession for him, but fixed bands of those widths were hopeless and I said so, again urging my flexible scheme. A vote was taken and the KBW-Montefinale scheme was lost, and the general idea of the Shaughnessy proposal voted. France, be it said, voted against both, thinking my plan too ambitious and Mr. Shaughnessy's too restrictive. Only Italy and the United States supported us at this juncture. Then abruptly it was found that no agreement could be reached readily on the width of the amateur bands—this meeting was still too large—and so this subject was referred to the same small group, more or less voluntary, which was going to meet that afternoon to recommend some narrow bands for short-wave broadcasting, and the meeting adjourned.

We took stock of the situation that noon. We had established the location of our bands where we wanted them. The flexible N.G.P. plan had been discarded, and rigid amateur bands of small dimensions were proposed. In the certainty that we were going to get clipped badly on the international waves, it became more important than ever to work for wider territory in the national waves than would be afforded by a rigid family of harmonically-related bands. At once we determined to abandon this idea and to negotiate for each band separately, as we found conditions, and to ask for wider non-exclusive territory in the 80-band rather than the paltry 100 kc. that would be afforded by any true harmonic plan.

It was an odd assembly which met that afternoon to decide upon the broadcasting and amateur bands. "Sub-teacuppers" is the proper term for us, I suppose. There were seven of us: Col. Mauborgne, Commander Craven, Major W. Arthur Steel of Canada, Dr. Van der Pol, of the Netherlands, representing the European broadcasters, Mr. Charles E. Rickard, representing the Marconi beam stations, Capt. H. Abraham, of Germany, representing Telefunken, and I. Major Steel was the only actual government delegate present and, aside from Col. Mauborgne and Commander Craven, the rest of us didn't even represent a govern-

ment. But this group was constituted for this purpose, and away we went. I kept out while the broadcast bands were being settled, and Dr. Van der Pol laid off when we got to the amateur matter. At last the moment had arrived! Now or never! But what an odd group to say what the amateur should have! It was a good enough group to decide the broadcasting question but it was only by chance that it was given the additional job of recommending the amateur bands.

I had explained to Commander Craven my idea for wider non-exclusive territory in the 80-band, to which he readily assented, and in short order he personally sold the meeting on 3500 to 4000 kc. non-exclusively for amateurs, our present American assignment. This was immensely better than I had hoped for; it assured us "a place to live", from which to sally forth to narrow international bands if we got short-changed below, as seemed unavoidable. Non-exclusive was quite all right, for we have always shared that band with army mobile, naval aircraft and naval vessels working naval aircraft, without trouble. Then we tackled 20, for which the proposal was 400 kc. There wasn't a chance to get any more. It really seemed about sufficient for the rather limited amount of day-light work which we amateurs do. We have had 2000 kc. there not because we needed it but because that width was dictated as the harmonic of our 40-band in defiance of the inverse economic value of the respective bands. I also found amateur occupancy of the 20-band entirely insufficient to justify a demand for any more, to say nothing of needing to hold my steam for the 40-band. The 20-band was located between 14,000 and 14,400 kc., those figures escaping the established services of the gentlemen present. And then we tackled 40, the real rub. That was our international night band, the place where we all assemble from every nation for our international communications. Next to our national bands, territory there was our most important need. I was asking for 800 kc. there and our own government was quite in agreement, as they had planned 7000-8000 kc. for us on the N.G.P. basis. But there was never a chance for it—it was too much more than the British idea of 100 kc. or Mr. Shaughnessy's generous 200 kc. The meeting attempted to find a place in the 7000-region where no commercial services were already in existence, as indicated by lists available. A start was made at 7000 kc. but only 200 kc. were available before a snag was encountered in the form of an existing German station. I didn't know, and don't know to this day, just what that had to do with it, but the idea was to get unanimous agreement of all the other interests to what was given us amateurs, and here the Telefunken representative couldn't agree because he had a station there! He might

have been out-voted here but the main teacuppers would have supported him the next day. Another location was tried but Major Steel objected, claiming that Canada had a large number of stations established in that 7000-8000 band which has been assigned to amateurs in Canada for four years. In fact Major Steel steadfastly refused to give his agreement to any large amateur assignment in that area, and he hurt us a great deal. He had been appointed by his delegation to represent them thru all the allocation matters. In these matters he sided most of the time with the European viewpoint, particularly the British, and but rarely with the American. It seems so strange, for surely Canada's radio destiny is the same as that of the United States, not Europe's—and that has been Canada's policy for years. But the Major's idea on amateurs was at least as bad as that of any European and he worked against us steadily. It will be a disappointment to Canadian amateurs to know that their representative did not uphold any of the usual policies of their government respecting amateurs, but instead was quite of the opinion that amateurs should not be permitted to occupy useful communicating waves, and that he did all he could to keep us out of them. He joined the Telefunken agent in refusing to agree to anything as rash as 400 kc. for amateurs in the 40-band. Eventually Capt. Abraham agreed to move one of his stations and a 225 kc. band from 7000 to 7225 kc. was determined upon. It is interesting to note that this band was clear of any established commercial or government stations, and that its limits are defined by the maximum width to which Capt. Abraham and Major Steel would agree in consideration of their established stations! Our band was no more than the Telefunken agent would agree to! Nor could it be widened or moved because of Major Steel. It seems so odd that such considerations as these should have entered into the making of the recommendations of this meeting, yet this little group had been appointed to make a recommendation and of course this was what they were going to hold out for, and the best efforts of our American people were unable to change it. I couldn't assent to these figures, and didn't, but that didn't alter the maximum to which the meeting could get agreement. Then the 10- and 5-meter bands were easily fitted into the picture, and we adjourned.

The next morning the sub-teacuppers reported to the teacuppers and, strange to relate, the only objection was from me! I was then holding out for 400 kc. at 40 instead of 225. By then I was prepared to recommend that we agree to the rest of the table but I thought we needed and rated more at 40 and I could see no good reason why it couldn't be spared to us. Capt. Hooper, as chairman, supported me, but the British

claimed that they had important services there and that it was out of the question. Capt. Abraham then said that the preceding day it had seemed too difficult to shift existing stations but that he would now compromise with 300 kc.—7000 to 7300. Mr. Shaughnessy would shift his stations too and agree. It meant 75 kc. more and it became apparent that it was the very maximum to which agreement could be got. But the fireworks weren't quite over, for Mr. Shaughnessy objected to our 10-meter and 5-meter bands being marked exclusively amateur, saying that we might succeed in developing the 10-meter band into useful communicating waves and that in that event we shouldn't be permitted any such exclusive possession of valuable waves. It was at length determined to compromise by opening them to "amateur and experimental". Altho a small point, it illustrates the determination with which the British pursued us at every stage of the game. And finally everybody agreed upon these figures for us amateurs and the whole report was accepted.

From that time on there was never a chance for any alteration in the figures. These meetings were strictly informal and not officially binding upon a soul present, much less upon the interests they represented. But it was considered that an agreement had been reached and there was an unspoken pledge to stand by the agreements. This pledge was at once the weakness and the strength of our position for, altho it made impossible any attempts to increase our 40-band allocation, it insured strong backing for the preservation of the table against any who might attack it. It



shortly became apparent that it was considered that our United States delegation, by having participated in the negotiations, was bound to support these allocations for amateurs, and in fact it was considered that we had accepted them too and for the same reason. Careful sifting of the situation showed that there wasn't a chance to get any agreement on anything greater. Besides, these figures really weren't half bad.

To make a very long story decently short, the teacuppers laid their work before Prof. Kennelly's sub-committee on allocations as a basis for discussion. It was hopped upon by various people, particularly folks who wanted to question the great width of the amateur assignments. Here Prof. Kennelly roundly defended us, and the very fact that it was considered that an agreement

had been reached amongst the major powers caused them all to stand their ground and defend the whole short-wave table against attacks. As a result, it was easily adopted in the sub-committee without alteration and similarly adopted a few days later by the Technical Committee. At length it reached the Plenary Session and there it was adopted just as easily, amidst great applause, for it was realized that a perfectly mountainous piece of work had been accomplished and that it was really a rather good job. This was the largest international conference ever held in the history of the world, with nearly eighty nations represented, and they had unanimously agreed upon the partition of wavelengths from 30,000 meters to zero.

This is the true story of the determination of the amateur wavelengths in the convention of 1927. Our wave-bands are shown in the accompanying table. If the reader feels that we got a satisfactory deal, give the credit to our United States Delegation. If they do not seem enough, they were the best that could be got in the face of united opposition. But I feel that we must consider that we have been most successful. We have received a great deal more than most of the world wanted us to have. With the single exception of our 40-meter band I believe we have all that we shall need. For our international night work in that band we shall have to devise new methods, perhaps new apparatus, and certainly we shall have to employ a greater measure of international cooperation than ever before. But all of these things are possible to us and we have always gloried in the necessity for licking a new job.

There will be time in succeeding months to analyze the new problems confronting us and to arrange for their solution. The convention does not go into effect until the first of 1929, so there will be time to adjust ourselves to the new situations. These new amateur wave-bands should be considered gorgeously ample for every country but ours, and we in this country will find a way. It should be emphasized, tho, that no nation is obligating itself to permit the existence of amateurs—that is strictly its own business—and unfortunately the conference offered no opportunity to insure the existence of amateurs in every country. Nor is any nation obligated to put the entire width of these bands at the disposal of her amateurs—in fact few of them will; the bands

are merely those which nations have internationally agreed are to be used for amateurs in countries which so wish. We may feel sure, though, that we have gone a long way towards selling the amateur to the administrations of the different countries, and now that there is international agreement on amateur territory and a nation may know that it is not stepping on the toes of another in giving certain waves to its amateurs, we may hope that there will be a much greater disposition in foreign countries to treat the amateur liberally. Believe us, they have certainly heard about the amateur at Washington!

And now, rapidly, some other amateur matters. Each administration will fix the maximum power of its amateur stations. The stations must be licensed and the administrations must assure themselves of the proficiency of the operators. The stations must comply with all the general requirements of the regulations, particularly as to observance of wave-length, stability of wave and freedom from harmonics. They must sign their calls at frequent intervals. The calls are to be assigned from the same "national blocks" as the calls of commercial stations, consisting of the one or two initial letters that indicate nationality in such calls, a single figure, and not more than three letters. These calls will be used in connection with the intermediate "de". Thus the governments do away with the necessity for our international intermediates—beginning in 1929. The other important amateur question was the nature of our communications, and that I have reported previously.

In the near future, probably the next issue, *QST* will print pertinent extracts from the Washington Convention applying to the amateur. We shall advise where and how the document may be obtained as soon as it is available. The coming year undoubtedly will see in *QST* much discussion and much new material and many new decisions based upon our new conditions, as we analyze them and learn their possibilities.

It has been a great two months, the hardest but the most interesting in my life. It has been a wonderful experience. I am proud that we may call it successful. The unyielding world has yielded, and we amateurs are safely written up in the greatest communications document of the age, the Washington Convention of 1927.



This Amateur Phone Business

By P. C. Lackey* and Dean Spencer†

AMATEUR radio phones have probably been the cause of more bad feeling under the head of, "Grief for the Transmitting Amateur" than any other thing he has ever been attempted.

After operating an amateur phone for some years we have arrived at the conclusion that most of the bad feeling has been justified. The moral is, "if you are going to use phones use a rig which will not disgrace the whole A.R.R.L. to say nothing of your own particular station."

We plead guilty to "getting quite a kick out of" operating our radio phone sets. The idea seems to prevail that *no one* except a "ham", a "lid" or a rank beginner even fools with phone. Unfortunately this is true to some extent but there are old timers who enjoy "chewing the rag" by phone. These men are not DX crazy, they know they have no chance to get a WAC certificate with a 15-watt phone set but they can get the RCC certificate easily and they find it enjoyable to handle traffic with people who have something to say besides "VY GLD QSO CUL 73", even though they are only a hundred miles away, which for that matter is not always the limit for a good phone of low power.¹

We still remember when we started our first phone set.

Says Lackey to Spencer: "Where do you get the dope on a phone set?"

"Ballantine," says Spencer.

So we got it down and read it. It is great stuff; every amateur should have it (phone or c.w.) but a lot of them don't.

"Now, how about QST?" says Spencer.

So we got down the complete volumes and looked them over. Plenty of dope on c.w. on receivers and on everything else and all of it FB but almost nothing about phone.² How come? We decided that QST was "agin" amateur phone and were all heated

*5AJ, Blanchard, Okla.

†5JU, 1302 Division St., Sulphur, Okla.

1. It is my sincere opinion that the operation of a phone should really not be permitted except to those who have demonstrated the ability to operate satisfactorily a c.w. set with d.c. plate supply. How many would pass that test?—Tech. Ed.

2. This has purposely been so because at HQ. we are convinced that phone operation should be touched only by those able to create a steady carrier wave which will not be wobbled whenever the modulator goes into action and thereby spread all over the tuner. If a change in plate voltage changes the wavelength the oscillator is not good for telephony—for that matter for use with a.c. and a key.—Tech. Ed.

up and ready to grab up a sheet of asbestos and write a letter on it when we saw that the League had persuaded the new radio commission that the amateur should retain the 150- to 175-meter band. Right on top of that we see a "stray" saying that QST will consider some articles on amateur phone.

"Let's write one," says Spencer.

"Nix!", says Lackey. "Who in Sam Hill told you we could write an article?"

"Well," says Spencer, "we can tell them about our experiences and they might print it if someone doesn't take a notion to write a real article."

So here we are.

The first thing is to build the oscillator and as QST has often remarked, "the circuit you like the best is the best for you."

Without even considering the modulation system, first get the oscillator going on the desired wavelength. In this case it must be one of the bands allotted to amateur phone and must emphatically not be in the 40-meter band. We believe the 170- to 180-meter band to be the most satisfactory as the very essential "DC tone" can be obtained much more easily in that region than on 84 meters§. Our sets accordingly work in the 170- to 180-meter region though if one insists on hunting for trouble they can easily enough be adapted to 84-meter work by simply changing the oscillator inductance.³

For no good reason, other than the fact that we "like it best", we use the Hartley circuit with shunt feed. Since this circuit has been thoroughly discussed⁴ we will say no more about it but refer you to the diagram.

3. The staff is of the opinion that because of selective fading the 80-meter band is much less favorable.—Tech. Ed.

4. Before decent modulation can be hoped for, the oscillator must be adjusted so that the antenna current will be proportional to the plate voltage. This can be done with the grid and plate clips and the grid leak and should go before any thought of modulation. Better put the modulator off for a few weeks, or altogether, if you can't get this adjustment. See the following reference in QST April, 1926, page 8; May, 1926, page 17; also page 43; June 3, 1926, page 29; July 1926, page 8, also page 29; August, 1926, page 19; Nov., 1926, page 22; December, 1926, page 9; January, 1927, page 14 and page 27; February, 1927, page 9; March 1927, column 2, page 17, and page 33 the same issue. Be sure to read "Some Light On Transmitting Tuning," July, 1927, page 24. None of the crystal control sets referred to operate in the 175-meter region but the necessary modification is obviously to multiply the constants all the way through by 2 or 4.—Tech. Ed.

§ This article was turned in before the 80-meter band was closed to phone operation. All information is applicable to the new 20-meter phone band.—Editor.

OSCILLATOR ADJUSTMENT

Use any of the methods described in previous issues of *QST* to determine what kind of a tone you have, then juggle the filter and the oscillator adjustments until you have an *absolutely pure d.c. whistle*. (Mainly, notes stay at the bottom of *QST*

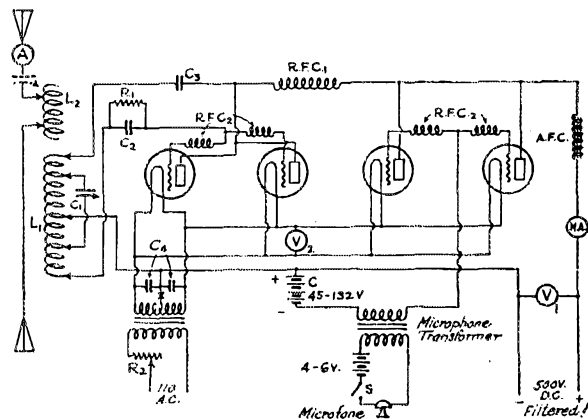

THE TRANSMITTER DIAGRAM

Shown mainly to point out that it is perfectly normal as to wiring and that good results depend on careful adjustment, not on a new circuit. The constants given are for 175-meter region which is where a phone should work best. The antenna happens to be a 5-wire cage 60 feet long, 40 feet up and L connected, but may be larger. The counterpoise is a 5-wire fan 90 feet long, L-1 12 to 18 turns No. 6 bare copper on 5-inch tube, tapped each turn.

L-2 25 turns No. 6 bare copper on 7" tube, tapped each turn.

R.F.C.-1—Three hundred turns No. 26 on 3" tube.

R.F.C.-2 15 turns No. 26 on 1" tube. Mount on grid terminal of socket.

A.F.C. Iron cored audio frequency choke or modulation choke. Inductance 6 henries. Made as described or used R.C.A.—UP415 or make from Ballantine's design page 151.

R-1 Grid leak, 5,000 ohms.

R-2 Radiostat or other suitable variable resistance.

X Closed circuit jack for cutting in telegraph key.

C-1 Primary tuning condenser, 500 μ fd. or larger.

C-2 Grid condenser 200 μ fd. or thereabouts.

C-3 Plate stopping condenser, 200 μ fd. or thereabouts.

C-4 Filament by-pass condensers, 600 μ fd receiving condensers.

V-1 Plate voltmeter.

articles but this is highly important. *Don't trust the other fellow's statement* as to your tone. People have repeatedly reported my 20-meter signal as d.c. when it had over 50 percent of 60-cycle modulation and three quarters of the people reporting 9XL call that signal d.c. although it has perhaps a 15 percent high frequency modulation—as much modulation as is used by some broadcast stations! Tech. Ed.) Past issues of *QST* have given the information on filters for everything from a motor generator to — a rock crusher! If you will start with that information (or Ballantine's) and do a little careful work you should have no difficulty.

MODULATION

You will notice that the usual D.P.D.T. switch for throwing all tubes in parallel is

absent. This is primarily a phone set, the switch causes losses, and the gain from putting four tubes in parallel is usually not very much worthwhile. When the set is used for CW the key is plugged into the closed circuit jack in the "center tap". This jack is indicated by "X" in the diagram.

A glance at the diagram will show that a microphone, microphone battery, microphone transformer, two additional r.f. chokes and an iron core audio choke (also called "modulation choke") are needed to operate the two modulator tubes. Microphone transformers appear to be scarce and a reasonably satisfactory one can be built from an audio transformer. Remove the leads from the binding post, tagging them as you do so, carefully remove the primary winding and replace it with as much No. 26 or 28 wire as possible. Then reassemble the transformer and bring the leads out to the proper terminals.

The plate reactor can be made in the same manner, if necessary, except that both primary and secondary windings of the audio transformer should be removed and replaced with one winding of No. 26 or 28 wire. This plate reactor really should have an inductance of 6 henries at least, for the UX-210 tubes.

A good speech amplifier between the microphone transformer and the modulator tube is worth while. A stage of push-pull amplification works very well at 5AJ. The thing can be supplied with the same A, B and C voltages used on the transmitter but this is complicated and we advise separate supply. While speaking of the supply a.c. may be used on the modu-

lator and oscillator filaments but the center tap *must* be right and don't forget that the plate supply must be *pure d.c.*

ADJUSTMENT

First, adjust the oscillator with the modulator tubes removed and don't go a step further until this adjustment is per-

5. Awful quality will result if the core of the transformer becomes saturated or the microphone fries. Keep the microphone voltage down. If the reactor is too small little modulation will result. —Tech. Ed.

6. Be sure to use a voltmeter and to make the adjustment indicated in note 5. If that adjustment is not made you are simply clawing around in the dark. Don't try to see how big the antenna current can be made or you will absolutely destroy the straight line ratio between plate voltage and antenna current. —Tech. Ed.

fect.⁶ Now insert the modulator tubes, connect a 45-volt C battery, close the microphone switch and put on the plate power. If the modulator tubes try to burn up add more C battery before going on. We have used as much as 135 volts for UX-210 tubes. When these tubes run at a decent temperature run a test with one of those very rare amateurs who really knows what decent modulation is. Then make final adjustments for best results.

We acknowledge freely that there is nothing new in the set we have described but we hope that our comments as to the extreme importance of adjustment may be of some benefit. Such adjustment having been made, the transmitters at 5AJ and 5JU have given very gratifying results. At 80 miles they have permitted communication by voice every afternoon for three weeks. This has been during the static season. Naturally, these transmitters have gathered in no extreme distance records (for that we have a 200-watt c.w. rig) but in four years of operation we have had reports from both coasts, from some 33 states and three Canadian Provinces.

As we remarked at the beginning we get much satisfaction from talking with our fellows and we really believe that the "amateur spirit" exists among the phone bugs.

Standard Frequency Transmission from 9XL

STATION 9XL is a special station, comprising one of the three portions of the "Gold Medal Station", WCCO-9XL-9WI at Anoka, Minnesota. WCCO operates as broadcast station, 9XL purely as a standard frequency station and 9WI as a general amateur station, the three transmitters having independent equipment and antennas but a common power supply. Through arrangements made by K.V.R. Lansingh of the Official Wave Length Station Committee of the Experimenters' Section, A.R.R.L. 9XL is operated on schedules regularly announced in QST. The work of operating the station is done without charge by Chief Operator Hugh S. McCartney and his operating staff.

While no guarantee of accuracy is made on a gratis service, it is the aim of the staff to maintain an accuracy of 1/10 of 1%, which is materially better than can be "held" by most wavemeters. The frequency values are based on the Standards of the Bureau of Standards and have been

checked by the Communications Laboratory of The Massachusetts Institute of Technology, also by Cruft Laboratory at Harvard University.

Important Notice—The continuation of this free service from month to month depends on the response received. Direct acknowledgments to "Experimenters' Section, A.R.R.L., 1711 Park Street, Hartford, Conn.," using ordinary stationary or else the special blanks supplied by the Experimenter's Section, on request. A goodly number of these blanks has been gathered and as the number grows we will gradually gain a unique and accurate record of transmission phenomena possible with no other station. Details on 9XL may be found on page 8 of the June issue.

9XL now uses a small percentage of tone modulation to make the signal distinctive.

SCHEDULES

(Figures are frequencies in MEGACYCLES per sec.; approx. wavelengths in parentheses.)

Friday Evening Schedules				Sunday Afternoon Schedules			
Central Standard Time				Central Standard Time			
Time (PM)	Schedule A		Schedule B		Time (PM)	Schedule C	
	f	λ	f	λ		f	λ
8:30	3.50	(85.7)	6.50	(46.1)	3:00	10.0	(30.0)
8:42	3.60	(83.3)	6.75	(44.4)	3:12	12.0	(25.0)
8:54	3.75	(80.0)	7.00	(42.8)	3:24	14.0	(21.4)
9:06	3.90	(76.9)	7.25	(41.3)	3:36	14.5	(20.7)
9:18	4.00	(75.0)	7.50	(40.0)	3:48	15.0	(20.0)
9:30	5.70	(52.6)	7.75	(38.7)	4:00	15.5	(19.3)
9:42	6.50	(46.1)	8.00	(37.5)	4:12	16.0	(18.7)
9:54	7.00	(42.8)	8.25	(36.3)	4:24	18.0	(16.7)
10:06	7.50	(40.0)	8.50	(35.3)	4:36	20.0	(15.0)
10:18	8.00	(37.5)	8.75	(34.3)			
10:30	8.50	(35.3)	9.00	(33.8)			

January	6	A
	8	C
	20	B
February	3	A
	5	C
	17	B

DIVISION OF TIME

- 3 minutes—QST QST QST nu 9XL.
- 3 minutes—5 sec. dashes broken by station call letters every half minute.
- 1 minute—announcement of frequency in megacycles per second (8.75 megacycles per sec. is sent as "8 r 75 MC.")
- 1 minute—announcement of frequency in megacycles cycles per second.

Special Notice—If you use the transmissions send a note to Experimenters' Section, A.R.R.L., Hartford, Conn.

—R. S. K.

Strays

The relay contest is coming. You haven't forgotten the dates—Feb. 6 to 19 inclusive have you? Better mark them on your calendar pad. If you live in the U. S. or Canada, get your entry in while there is opportunity. It will be too late to enter after Feb. 1.

Municipal Ordinances on Radio Transmission Unlawful!

By A. L. Budlong*

IN the excitement surrounding the decisions of the International Radio Conference regarding amateur wavelengths, it is easy to lose sight of a less spectacular but nevertheless important victory that the amateur has just attained in another direction.

We refer to a court decision in the District Court of Kentucky, where Judge A. M. J. Cochran has recently handed down an opinion that municipal ordinances designed to limit or regulate amateur radio transmitting stations are unlawful and unconstitutional, and cannot be enforced.

The story behind the decision is a long one and it is only now that it can be told. Beginning about a year ago various towns and cities over the country began to pass local ordinances seeking to restrict and control the operation of amateur and broadcast transmitters within the city limits. The A.R.R.L. immediately recognized this as a great danger to amateur operation and had unpleasant visions of the dire consequence that might result if all the cities and towns throughout the U.S. got the same idea.

After careful deliberation at its last meeting, the A.R.R.L. Board of Directors decided that the best way to combat the ordinance proposition was to select some particularly obnoxious ordinance and endeavor to get a court decision against it, which decision could thereafter be used as a precedent in discouraging similar moves on the part of other cities. Director Segal, who is a bang-up attorney in private life, was appointed as League counsel, and we began prowling around for a suitable ordinance to pick on.

It was finally decided to open the battle in Portland, Oregon, which city had some time previously passed an ordinance that prohibited all kinds of interference, including amateurs. Director Segal went to Portland to prepare a brief and take the necessary steps to secure an injunction in the courts. In this work he was assisted by our Northwestern Division director, Mr. K. W. Weingarten.

Just as they were ready to file the case with the courts, however, the city authorities got wind of the suit, became panicky and upset the apple-cart by calling a special meeting of the town council and revising their ordinance so that it wouldn't apply to amateurs.

It was a big moral victory, but it meant that we didn't have our court decision, and several months' work was lost.

About this time, however, another ordinance had turned up which had all the earmarks of being just what we wanted. The town of Wilmore, Kentucky, had passed a measure which required the licensing of amateur stations, a \$100-yearly license fee, and various other provisions designed to limit and control amateur operation.

Fortunately there was an amateur station in that town, also, so again Mr. Segal went to work to prepare a case. To make a long story extremely short he was successful this time, and after several months work our Counsel-Director emerged with a clean-cut court opinion against such regulatory measures, and, shortly after, an injunction preventing the town from enforcing the ordinance. The court decision is so important that we print it in full:

"This suit is before me on defendant's motion to dismiss the bill for want of equity and that it does not state facts sufficient to entitle plaintiff to the relief which he seeks.

"The plaintiff is an amateur radio operator. He lives in and operates an amateur radio station located in the City of Wilmore, a municipality of this State located in this District. This he has done since October, 1924. He has a license to do so from the United States. It was granted October 19, 1925, for two years by the Secretary of Commerce, under the Act of August 13, 1912, and was extended March 15, 1927, by the Federal Radio Commission, appointed under the Act of February 23, 1927, by General Order No. 1 until further orders therefrom. The designation of his station is 9ALM.

"On October 1, 1926, the defendant by its Board of Council passed an ordinance requiring all persons, firms and corporations to pay a license tax therefor and providing a penalty for failure to do so. The tax provided is not on the property of the radio operator, but on the business of radio broadcasting. Radio communications are all interstate. This is so though they may be intended only for intrastate transmission. And interstate transmission of such communications may be seriously affected by communications intended only for intrastate transmission. Such communications admit of and require a uniform system of regulation and control throughout the United

*Assistant to Secretary, A.R.R.L.

(Continued on Page 70)

The Grinding of Quartz Plates

By E. G. Watts, Jr.*

THE HIGH cost of finished quartz oscillator plates has prevented many amateurs from enjoying the unique advantages of crystal control. Since a large part of the value of a finished plate is presented by manual labor in grinding, it is not likely that existing prices can be lowered. However, the amateur, as he is accustomed to do in other things, can perform the labor himself. I have found no particular difficulty in grinding to a finish the blanks which are obtainable from optical houses, with no more equipment than a micrometer, some plate glass, and grinding material. The blanks are usually about one inch square, and somewhat over one millimeter thick, and are cut at a predetermined angle from the natural crystal.

Experience has led me to believe that the quality of a plate as an oscillator is in inverse relation to the amount of variation in the thickness. Most plates refuse to oscillate without added feedback if this variation is more than one-half percent of the thickness. Another important factor is the condition of the edges. Unless carefully rounded and free from nicks oscillation will be weak. It is not uncommon to find that finishing the edges means the difference between strong free oscillation, and oscillation which added feedback is necessary to sustain.

Keeping in mind these requisites for a finished plate, let us see what pit-falls beset us in obtaining them. The plates are cut from the natural crystal at a definite angle to the electric axes. This process has been described in *QST* for Nov., 1925 and Sept., 1926. In removing any amount of quartz from a plate, one can readily see that this angle could easily be altered enough to upset things. As shown in Fig. 1, the X and Y axes are only thirty degrees apart. To make matters more precarious, plates are often cut at an angle between these axes to reduce the temperature coefficient. The result is that an alteration of only a few degrees is sufficient to shift the plate's frequency-thickness ratio from the 104-meter per millimeter ratio of the X axis to the 117 ratio of the Y axis. This change can occur at a critical time in the grinding process, and result in a ruined plate. Restoring the former relation is of course a very uncertain process. If the plate were to shift from the higher ratio to the lower it could neatly jump the band into which it was to be ground.

To avoid this possibility it is obviously necessary to preserve the original angle of

cut. One side of the plate is therefore identified and left alone in the grinding process, with the exception of a light grind to make it as plane as possible. There is little evidence that the actual planeness of the faces has much to do with the oscillation properties as long as the faces are parallel. It is well, however, to remove any high spots which might make the grinding difficult on the other side. Beyond this I have not found it necessary to go to any great lengths to obtain plane faces.

Having observed this precaution regarding the angle there is practically nothing

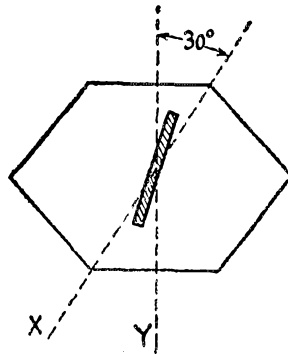

FIG. 1. ILLUSTRATING THE ANGLE OF CUT

else which can cause a plate to become a "dud" in the grinding process. It was formerly supposed that a plate might suddenly cease to oscillate for some mysterious reason, but I have found no grounds for such a belief.

The grinding process can be divided into five steps:

1. Taking the light grind on the reference side.
2. Grinding the other side roughly parallel for a test to determine characteristics so that the finished thickness can be calculated.
3. Rough grinding to nearly the finished thickness.
4. Working the variation down.
5. Finishing (edges etc.).

It is necessary to have several pieces of plate glass which may be anything over about six inches square, and $\frac{1}{4}$ " thick, for the several steps of grinding, so that a change can be made when the surface becomes too concave. This has happened when the corners of the quartz insist on going

*4FM, 1024 S.W. 9th St., Miami, Florida.

down too rapidly; but it is best not to wait for this to show up, especially on the last few cuts, when it is very important to be able to control the grinding points.

Plate glass is to be preferred to other kinds. I would not want to trust ordinary window glass, as it is not always uniform, and unfortunately I know nothing about the uniformity of photo plates. Automobile glass is the best quality plate glass usually. The idea is to have sufficient thickness to give a working surface with no resiliency, as well as a plane one. Pieces as small as 6" square allow ample grinding surface, but it is well to have some margin, so that it is not necessary to run the abrasive over the edges. Two grades of abrasive are necessary.

Grade "A" valve grinding compound mixed with kerosene is not too coarse for roughing. In this stage several thousandths are to be taken off at a time, and this grade

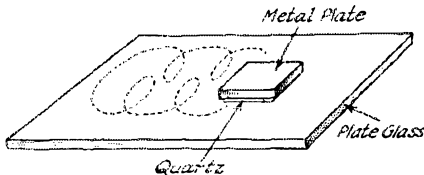

FIG. 2. GRINDING USING THE METAL PLATE

mixed with kerosene does the job well. Grade "A" is for finishing valves, and will not be found too scratchy for roughing quartz, as the coarse grade "D" might be. I have never had enough experience with emery, etc. to know the approximate grades of coarseness or fineness that the number indicate, but 150 emery is not far from the grade "A" compound in consistency.

A grade of carborundum of about the granular size of pepper or finer does for the fine grinding. Here again, kerosene is used to "float the chips". It has better consistency for this purpose than water, and does not evaporate so rapidly. Carborundum is to be preferred to emery, as the latter is not uniform. A ten-thousandths reading micrometer is to be preferred, although a thousandth reading one can be made to serve for plates over 75 meters, as it is possible to estimate closely enough. For 40-meter plates, however, a ten-thousandths tool is none too fine. Starrett's No. 218 C- $\frac{1}{2}$ -inch micrometer is an ideal tool for the job, as its anvil faces are smaller than in larger models. It is well to place the micrometer in a holder of some sort so that both hands are free to handle the plate when measuring.

In taking the light cut on the reference side, place a flat metal plate over the quartz as shown in Fig. 2, moistening it

with kerosene so it will stick. This metal plate may be of brass, $\frac{1}{4}$ " thick, and about the size of the quartz plate, with a face previously ground flat using the grade "A" compound and kerosene and another piece of glass. Using enough kerosene with the carborundum to allow easy motion, move the plate with a circular motion, describing a circle about two inches in diameter, and gradually working over the whole surface of the glass. When the plate begins to scrape, use more kerosene. Turn the plate under the fingers periodically so as to generalize the pressure, using as little as possible.

It is practically impossible to determine by any common methods just when the bumps have been worked out, but as this is not of great importance, it can be considered as accomplished after a short period. This completes the first step.

Marking the reference side with white paint (do not rely on lead pencil marks as erasing may be disastrous) measure the plate in nine points: four corners, four centers of sides, and center as shown in Fig. 3, marking the thickness; noting the high points, place the quartz on the glass with the fingers properly distributed (without the metal plate this time) for pressure on these high points. Since the plate will be quite thick at this stage, it will oscillate with a relatively large variation (that is comparatively deep hollows and large bumps do not keep it from working). Measuring and grinding periodically, work the variation to a reasonable value. Washing with Carbona (or any grease solvent) test the plate for oscillation, calculating from the thickness and wavelength the ratio, and thereby the finished thickness on the desired wave. This will complete the second step.

Mixing the grade "A" valve grinding compound with kerosene until it is quite liquid place it on the glass. It is not necessary to make any changes of glass until the roughing is done. It will not be necessary to make more than two or three measurements during the roughing. Being very careful to keep the reference side up, use the metal plate again, and bear with some pressure taking moderate care to equalize the pressure so that it will not be difficult to work out the variation. This will probably be several thousandths when the plate is within a few meters (by calculation) of the finished wave. Make enough allowance so that there will be no doubt about leeway to work the variation in before the finish is reached.

The fourth step is the longest and most tedious. Here we discard the metal plate again in favor of fingers and use the fine abrasive. Use just enough kerosene so that

it does not come up over the plate too much, as it is difficult to keep the thickness numbers easily legible. The old numbers are to be wiped out before each measurement of course, but it is desirable to be able to check how much has come off each time on a certain point. It is best to make measurements during this step at an interval of from five minutes at first, down to one or two, when the variation is small, marking the thickness in the usual nine points. A factor related to this stage of the grinding is what may be called "grinding efficiency", i.e., to be able to make a reduction in the variation without taking off from the lowest point on the plate. It is fairly easy, by careful distribution of pressure, to maintain a 100% efficiency. For instance, if one corner of the plate is lower than the rest, and it is desired to "lay off" that corner, it should be found that, while a reduction of several ten-thousandths may have been made elsewhere, the low corner remains the same. By careful application of this principle it is possible to work a variation down within very close allowances.

While this treatise will relate to the preparation of plates as low as 40 meters, it is evident that the plates on the order of 80 meters do not require nearly as much care to obtain good oscillation. Thus, with plates designed for 80-meter work, the fourth step can be said to be terminated when the variation has reached a figure near five hundred-thousandths (half a ten-thousandth) or even one ten-thousandth as measured by the micrometer, being sure that no high or low spots exist between the nine points of measurement. This can be determined by sliding the plate thru the micrometer across these spots. If an off point is found, it will be necessary to mark it specially and grind it out. The grinding usually proceeds uniformly, however, and it is rare to find an off point.

With plates which are to be ground to the vicinity of forty meters, the variation must be worked in as closely as possible. With a ten-thousandths reading micrometer, it is possible to estimate to within five hundred-thousandths. Beyond this point, which is not fine enough for the forty-meter plate, the micrometer ceases to be of use as a measuring instrument, and can henceforth be used only to compare different points on the surface of the plate. This is done by what may be called the "slip and stick" method. Hills and valleys on the faces can be felt very plainly by sliding the plate gently thru the micrometer. It is very likely that variations of less than 25 millionths can be felt in this manner. Differences so small as to not be discernible on the vernier scale markings can be plainly felt. It is a simple matter to mark these spots and grind them

out. The rapidity with which they disappear also attests their minuteness.

One must grind very lightly, or a valley may appear where there was a hill. It is also necessary to be extremely careful not to strain the plate during this process, as a piece of quartz .010" or so thick is not very rugged.

When the variation has been worked to within the desired value, the fifth and final step is finishing the edges. As stated before, these have a large effect on the oscillation. It has not been determined just what it is that is responsible for this, but nicks which exist on any sharp corner are suspected. Therefore it is desirable to smooth off the

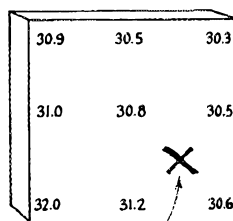

Paint mark to identify reference side, which must not erase.

FIG. 3 ILLUSTRATING METHOD OF MARKING THE THICKNESS AT THE NINE POINTS WHICH HAVE BEEN MEASURED WITH THE MICROMETER

Specimen markings shown are in the thousandths, and indicate that the plate is high on the lower left hand corner

edges so that there will be no nicks. A bevel leaves corners, so a rounded edge is preferred. The corners of the plate should not be rounded too much, however, as it is then difficult to place a round edge on them. Nicks which are visible must of course be ground out, even if a thirty second of an inch must be removed to do it. Grinding off one edge or another does not appear to affect the frequency, but has a somewhat haphazard effect on the strength of oscillation. I have not been able to lay down a rule for this effect, and grinding off of one dimension or another may either strengthen or weaken the oscillation. Neither have I been able to find a particular relation between the shape of the plate and the output, although I have seen poor plates which I suspected might be caused by an oblong shape. Rectangular plates are to be preferred to round ones for electrical as well as mechanical reasons.

In selecting a plate which is to be ground to forty meters, it is unwise to use any but those responding to the lowest thickness wavelength relation so that they may be as thick as possible. Plates cut with the thickness parallel to the "X" axis show the

smallest number of meters per millimeter. This may mean a difference of several thousandths in the finished thickness, and this is a gain well worth while. With 80-meter plates, the ratio is immaterial, as the plates are plenty thick enough in any case.

While it is considerably more difficult to prepare a forty-meter plate, I have not found any other difficulties. No trouble has been experienced with cracking, nor in obtaining sufficient power for any purpose that an 80-meter plate might be used for. In fact, a frequency doubling power and amplifier with its necessary high bias battery, will cause more difficulty than a "straight thru" forty-meter outfit.

A word about mountings will not be amiss at this point. A forty-meter plate must have a very good mounting for best results. It is preferable to keep the top plate pressure as light as possible, and it should be made of a thin plate, but not so thin that it will not hold a flat surface. A thickness of 1/16" will be found convenient. The connection to the top plate must exert no pull in any direction, and will of necessity have to be very light. A very excellent material for plates is German silver, or Monel metal, alloys of nickel, and are practically untarnishable. The former is used in the construction of soda fountains, and some may be obtained from this source. Nickle-plated plates of any other metal will probably be just as serviceable. There is little evidence that slightly tarnished plates have any marked effect on the output.

A necessary adjunct to the grinding operation is a test oscillator. While it may seem that the conventional power oscillator cir-

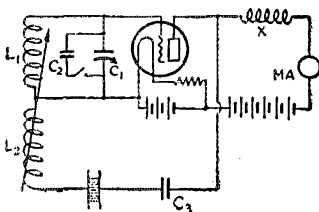

FIG. 4 TEST OSCILLATOR CIRCUIT

cuit will be best for this, it has certain disadvantages for test work. It is not possible to advance the feedback without producing self oscillation, and neither can the feedback adjustment be made independent of wavelength change. A circuit which overcomes these difficulties nicely is shown in Fig. 4. It will be recognized as a "modified Hartley" or "tuned grid with plate tickler" with the usual blocking condenser replaced by the crystal. In this circuit,

fundamentals can be brought out that will not appear with any other, and without the tube going off into self oscillation. The amount of feedback is smoothly variable by the coupling between L1 and L2. It can be set so that only the principal fundamental of a plate will show up, or so that a collection of other fundamentals appear. This circuit also gives a larger percentage of movement of the plate current meter when a fundamental is struck. The movement of the meter is upwards instead of downwards as in the conventional circuits using bias battery on the grid. The response is so large, in fact, that if the meter is of low enough range to give good indication of the weaker fundamentals, the stronger ones will run it off the scale. Using 45 volts with a 201-A tube a 0-5 milliampere meter will be found suitable. With the stronger fundamentals it may be found necessary to reduce the plate voltage to 22, to keep the current within the range of the meter. The tickler coupling can be loosened to provide the same effect. The range of coupling should be such that it may be reduced to a value equivalent to the amount of feedback which occurs thru the tube capacity in the conventional tuned plate power oscillator. This value may be approximated by observing when oscillation is obtained on the main fundamental only, although others can be picked out with tighter coupling. In order to make the circuit of wide usefulness, condenser C1 can be made large enough to allow a tuning range from 40 to 150 meters, and further extended by the parallel condenser C2 when desired. No trouble will be had with critical tuning, no matter how large C1 is made. The condenser C3 is necessary only when there is danger of having the mounting plates short-circuit the plate supply. The choke X can be one such as would be used in a receiver. With this oscillator it will be possible to follow the plate during the grinding process without having to work the variation down a great deal. The circuit is *not* well adapted to power and transmitting use as it accentuates the temperature coefficient of the plate, and the frequency changes also, more readily than do other circuits.

I will be pleased to advise anyone who runs into difficulties, if they will write me.



Radio Frequency Chokes for Receivers

By Glenn H. Browning*

THESE seems to be a great lack of exact data on radio frequency chokes in general and somewhat hazy ideas in the minds of radio engineers in particular as to the method to be used in measuring their efficiency. The writer, in endeavoring to get some exact data on performance of a choke for one particular purpose, had occasion to talk to a number of well-known engineers and was surprised at the difference of opinion given.

Every day, more r.f. chokes are used in various parts of radio circuits so that it is

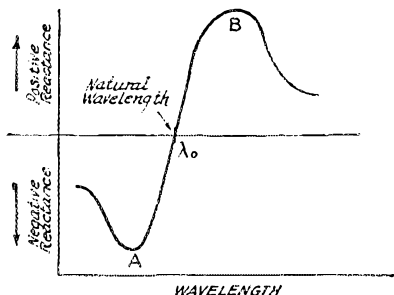

FIG. 1. GENERAL NATURE OF THE IMPEDANCE CURVE OF COILS USED AT FREQUENCIES NEAR THE ONE TO WHICH THEY TUNE

In practice the curve is found to undergo considerable changes as to shape, steepness of the part A-B and by the appearance of additional humps and hollows. These are occasioned by the coil resistance and the manner in which the tuning capacity is placed, that is whether it is lumped in a condenser or distributed along a coil with many turns. The coil-and-condenser, the single-layer coil and the complex coils all show different curves. Which is preferable depends on the effect that is wanted—very high impedance at one frequency or fairly high impedance over a range.

timely to analyze their uses and outline a number of different methods used to measure efficiency.

R.f. chokes may be used either above or below their natural period.¹ Suppose, for example, that the distributed capacity tunes the choke to 600 meters. This choke would act as a small condenser at wavelength below 600, that is, it would have a capacitive reactance, while at wavelengths above 600 it would act as an inductance or a positive reactance. Thus, the reactance curve plotted against wavelength would look something like Fig. 1, the exact shape de-

pending upon resistance and the amount of distributed capacity per unit of inductance. Fig. 2 shows a receiving circuit with five radio frequency chokes, four of which are used in different capacities. Radio frequency chokes No. 1 and No. 3 are used for a parallel feed system and are employed to keep radio frequency current out of the "B" supply. Naturally, their impedance to radio frequency current, whose frequencies are within the range to be received by the set, should be as high as possible. Usually these chokes are worked below their natural wavelength. Radio frequency choke No. 2 is used as a positive reactance in the plate circuit of the second radio frequency tube to make the grid oscillatory circuit tune sharply.² This coil might or might not be called a radio frequency choke, but we shall at least consider the definition of that quantity to be sufficiently broad to cover that phase. Radio frequency choke No. 4 simply acts as an impedance grid leak, but should have its natural period with the grid-filament capacity of the tube well out of the wavelength range being covered with the receiver. Radio frequency choke No. 5 is designed to choke back radio frequency current so that it will pass through condenser C, and not enter the audio amplifier.

Let us now see how we should go about measuring each coil for its respective purpose.

Radio frequency chokes No. 1 and No. 3 should have their impedances as high as possible to currents whose frequencies are in the wavelength band covered by the set. The most convenient way to measure this impedance was found to be the method shown in Fig. 3. A source of E.M.F. whose frequency could be varied was supplied from a five watt oscillator. The voltage across this source was measured by a Rawson thermal voltmeter. The radio frequency choke to be measured and a resistance³ of 5,000 ohms were connected as shown. A vacuum tube voltmeter, previously calibrated, was then connected across the 5,000 ohm non-inductive resistance and the voltage across this resistor noted. Knowing the voltage and the resistance, the current through resistance is easily calculated. Consequently, E and I are known, from which Z (the impedance of the circuit) is deter-

*Browning-Drake Corporation, Cambridge, Mass.

1. See the remarks on Fig. 1, also note comments of Austin Liddbury on pages 27-31, October QST.

—Tech. Ed.

2. Most amateurs know that if there is a negative reactance in the plate of a radio frequency amplifier tube, the coil-condenser tuning system will be very broad because no regeneration whatsoever is introduced.—Author.

3. A Tohe Veritas resistor was found to be excellent for his purpose.—Author.

mined. The resistance of 5,000 ohms in comparison with the impedance of the choke being measured, was so small that in some cases it could be neglected. Of course, if

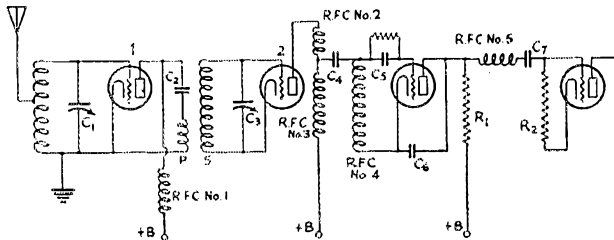

FIG. 2. A DIAGRAM OF A BROADCAST RECEIVER TO SHOW VARIOUS POSSIBLE USES OF CHOKES

the chokes being used have a smaller impedance, the resistance should be reduced. There are several slight errors introduced so that the method is not extremely accurate, but is excellent for commercial purposes. A slight error is made in assuming that the resistance is negligible in comparison to the impedance of the choke. This

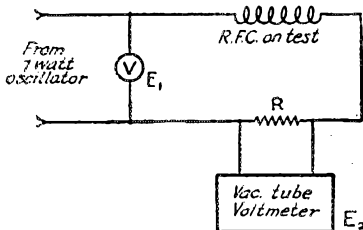

FIG. 3. A METHOD OF MEASURING CHOKE IMPEDANCES

The voltmeter V is a thermo-voltmeter which is correct at radio frequencies. The resistance R is chosen so that it will be small as compared to the impedance of the choke, thus it becomes fairly correct to assume that the current thru the choke is E_2/R and the impedance of the choke is E_1/I or E_1R/E_2 . Some thought must be given to the avoidance of any resonance effects from the input system at the left.

can be made as small as one pleases by making R small. An error is also made in assuming that all the current I passes through the resistance R as some will pass through the capacity of the tube used as a vacuum tube voltmeter. This, however, is very small as the UX-199 tube used has a small grid-filament capacity.

The result of a set of measurements on two different chokes is given in Fig. 4. Choke A has an inductance of 148.8 mh. and a natural wavelength of 1,397 meters. It was used below its natural period and, conse-

quently, had a capacity reactance over the band from 200 to 560 meters. It will be noted from the chart that it was a suitable radio frequency choke to be used for a parallel feed system in a receiver as its impedance was never below 40,000 ohms. Its curve of impedance was regular and, as would be expected, had a rising characteristic with wavelength. On the other hand, choke B, whose inductance was 49.4 mh. with a natural period of 3,500 meters, had an impedance less than 1,200 ohms and a characteristic which was anything but uniform. It should be noted that in the broadcast band choke A had roughly three times the inductance with a small distributed capacity a combination which would seem to be more desirable.

Let us now consider how to choose radio frequency choke No. 2 in Fig. 2. As has been indicated before, this choke is to have a positive reactance so as to make L_2C_2 tune sharply without at any time throwing that circuit into oscillation. By placing a calibrated variometer in the plate circuit of tube 2, Fig. 2, the amount of positive reactance necessary to make L_2C_2 oscillate could be easily found. It would probably be about 3,000 ohms at 200 meters. Therefore, the reactance of this choke, minus the reactance of choke No. 3 (choke No. 3 reactance would be negative) should never exceed about 2,900 ohms. The necessary measurements on radio frequency choke No. 2 consist in determining its natural period (this should for a broadcast receiver always be kept below 150 meters) and determining its inductance so as to give the correct reactance as indicated above.

The most convenient way of determining the suitability of radio frequency choke No. 4 is to place it directly across a vacuum tube voltmeter, noting the readings on the meter when different frequencies in the band to be used are induced directly in the choke. Any tendencies toward natural periods, such as were indicated in choke B, will show up by great variations of the meter as the input E.M.F. frequency is changed slightly. Of course, this choke should have none of these periods for most satisfactory operation. It should also have as high an impedance to radio frequency current as is practicable. This may be determined as previously.

Although radio frequency choke No. 5, in Fig. 2, is used in somewhat different capacity than any of the others, its prerequisite is large impedance to radio frequency current with no natural period in the range of frequencies to be received when combined in the circuit shown, that is, with R_1 and

C. Natural period could be determined by placing a vacuum tube voltmeter across either R_1 or R_2 and noting the meter's reading as different frequencies are induced directly in the choke.

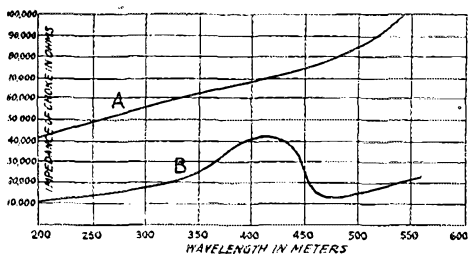

FIG. 4. CURVES ON SOME RECEIVING CHOKE COILS

Curve A is for a coil with an inductance of 149 millihenrys and a natural wavelength of 139.7 meters. Curve B is for a coil with an inductance of 49.4 millihenrys and a natural wavelength of 3500 meters. Note that coil A has a lower distributed capacity and a higher inductance, also that it is being operated within reasonable distance of its natural wavelength.

The writer has endeavored to give a short analysis of the radio frequency choke problem and he sincerely hopes that these notes may be beneficial to those using chokes in various circuits.

New Station Licenses

IN last QST we announced the issuance of new amateur regulations by the Federal Radio Commission, and a new station license which was gradually to supplant the existing Department of Commerce licenses. Supplies of the new license form have now been sent to the Supervisors of Radio, with instructions to recall existing amateur station licenses and replace them with the new F.R.C. form. The Radio Act of 1927 requires that all persons requesting a station license first make formal application therefore, and so the Supervisors, as rapidly as they can get around to it, are sending out notices accompanied by a blank application form, which is to be executed and returned with the old license, whereupon the new one will issue. Holders of temporary station licenses issued since March last have already filled out the required application form, and therefore no new application will be required of them; they will receive a regular license automatically, based upon the original application.

With 17,000 amateur stations to care for, this is a large order for the Supervisors, and it will be some months before the job is completed. The work has already started in some districts, however.

We mentioned last month that we were

in general quite pleased with the new "blanket" form of station license provided for us. Current instructions to Supervisors state that inasmuch as all amateur stations, under the law, must be operated in accordance with the provisions of the Radio Act of 1927, the Supervisors need not concern themselves with the details of the station for which a license is requested, and applicants for amateur station licenses need not be required to submit diagrams of their transmitters or to indicate the type of plate supply used, etc. This is a part of the new plan that an amateur station should be permitted to do anything legal which doesn't interfere with other services, but that quiet hours are going to be imposed upon it if it does interfere, regardless of apparatus used.

It is to be emphasized that the new amateur regulations and the new amateur station licenses have *no connection whatever* with the new provisions of the International Radiotelegraph Conference. The latter do not necessarily go into effect until 1929 (alho they may before). The new licenses are based upon *existing* regulations of the F.R.C. and relate to the operating privileges which, with but minor variations, have been in force for the past four years.

New instructions governing the issuance of portable amateur station licenses have also been issued. Portable stations in general are divisible into two classes. The usual roaming station for which a portable license is generally sought will carry the usual station license, with the usual amateur call, but the license will indicate that the station is portable and bear the restriction "Valid only for operation in the _____ Radio District". Portable stations desiring to leave the district will be permitted to do so only for definite trips, for the duration of which they will be given a term license carrying a special call which consists of the district numeral followed by the letters ZZA, ZZB, etc. Supervisors of the districts in which the station will be operated are to be notified of the facts by the issuing Supervisor, and at the conclusion of the trip the license will be cancelled and the call restored for reissuance. The ZZA-ZZB calls will be issued only to portables which contemplate definite excursions beyond the border of their home district.

—K. B. W.

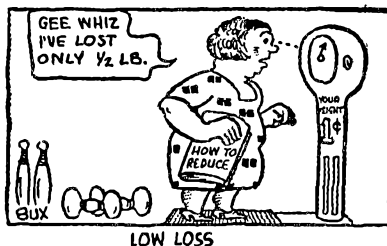

A Portable Power Supply

By Rudolph Sturm*

I HAVE done quite a bit of experimenting along the lines of portable and emergency transmitters and have never been satisfied with the methods so far used to obtain the high voltage plate supply.

I have used spark coils with the ordinary means of primary interruption (vibrator) and also with mechanical interruption using a chopper driven by a small 6-volt motor as shown in Fig. 1A. The efficiency of an outfit of this kind is low and the maximum output limited to about 10 watts at which the input to the motor driving the chopper is about 18 watts and the input to the coil 20 watts. The over all efficiency is 26 per cent. The disadvantage with this system is that if using one transmitter tube it utilizes only one half cycle. The voltage of the other half rises so high that it is almost certain to break down the tube somewhere. This trouble could be overcome by using a

spark coil but the output was quite a bit higher as was also the efficiency. It was plain that one could not easily handle much power in this manner, therefore it was de-

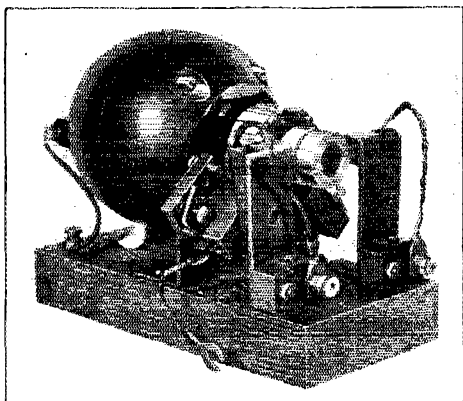

END VIEW OF THE COMMUTATOR OR MOTOR-DRIVEN REVERSING SWITCH

special spark coil with fewer secondary turns or by connecting enough capacity across the output of the coil, in which case the output voltage will be reduced, and with it the output too.

The next method that seemed promising was to use a transformer instead of the spark coil retaining mechanical interruption of the input voltage. This proved disastrous to a perfectly good transformer as it promptly broke down. After building a transformer for the purpose it was found that the characteristic was the same as the

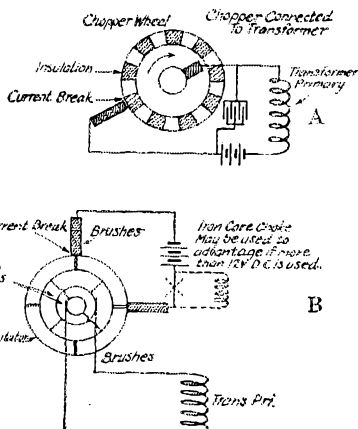

FIG. 1 COMPARISON OF INTERRUPTOR AND REVERSER OR COMMUTATOR

The interruptor or chopper can be operated with some satisfaction if a spark coil is used but even then the output will be low and there will be a tendency toward sparking at the chopper. The output of the commutator and transformer will be higher, there will be less trouble with sparking and if a center-tapped secondary is used two tubes may be operated back to back.

ecided to rebuild the chopper into a motor driven switch that will reverse the current therefore make an alternating current out of the d.c. input which will have the same voltage characteristic on both halves of the cycle.

The 6 volts of storage battery supply are changed to something less than 6 volts a.c. and then stepped up as high as wanted by the aid of a transformer. The output is limited only by the capacity of the battery if the unit is properly built. My converter puts 100 watts on the plates of two UX-210 tubes and also supplied 7.5 volts to the filaments. (See Fig. 3) With a 12-volt battery as the source of supply 250 watts were fed to three UX-210 tubes in parallel besides the filament power of 7.5 volts and 3 3/4 amperes. The a.c. voltage can of course be stepped up or down as desired by

1. The voltage at the output brushes is somewhat uncertain and should be measured with a good a.c. voltmeter, which will give a nearly correct reading. The uncertainty as to IR drop and wave form makes calculations worthless.

The ordinary 0-15 a.c. filament voltmeter is not of much value at voltage below 7.—Tech. Ed.

*9BQY, 1369 West Minnehaha, St. Paul, Minn.

arranging proper windings and taps on the transformer.

As to the construction of the converter I believe the photos are clear enough to show how the parts are arranged. The 4-segment commutator shown in the draw-

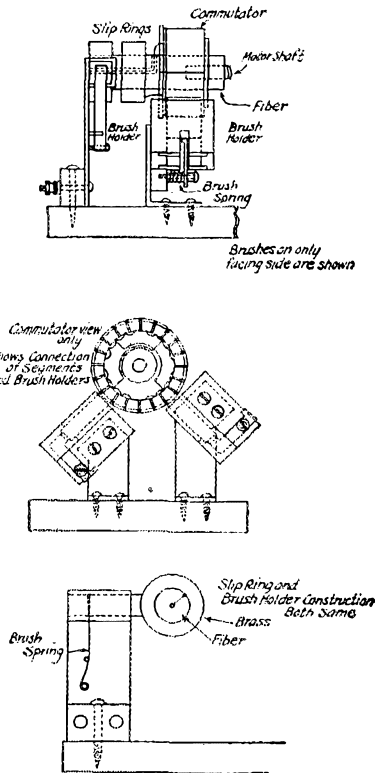

FIG. 2 CONSTRUCTIONAL DETAILS OF THE COMMUTATING ARRANGEMENT

ing of Fig. 1B is really a 20-segment commutator taken from a discarded 110-volt motor. Five segments are tied together to form one. They are interconnected as shown in the diagram. The output frequency depends upon the speed of the motor and the number of sections in the commutator. The formula for this is

$$F = \frac{P \times \text{R.P.M.}}{120}$$

where F = frequency,

P = number of commutator segments, R.P.M. revolutions per minute and 120 is a constant.

The commutator brushes will have to be arranged as many degrees apart as any two segments of opposite polarity.

Example:

4-segment commutator 90°

6-segment commutator 60°

8-segment commutator 45° or 105°
10-segment commutator 36°-108°-180°

etc.

The motor driving the commutator and slip rings should be shunt wound, mine being a 110-volt motor that I rewound for 6 volts.

As to the dimensions of my converter; the motor is 3½" in diameter and 3½" long, the commutator 1½" in diameter and ¾" wide, the slip rings ¾" in diameter and ¾" wide. The commutator brushes are ¼" × ⅝", the slip ring brushes ¼" square the base 7" × 3½", the height is 5" and the weight 4¼ lbs.

The advantages as compared to a motor-generator are that the cost is low, the device weighs much less and is more compact, also it is very rugged, not being injured by getting damp or even wet. The transformer can be put in a water-proof case. Since the transformer can be changed at will the whole rig is very flexible as regards output voltage. Summing up the whole thing I think it is the "berries" for a portable or emergency transmitter when a.c. mains are not available as the whole transmitter can be supplied by the battery that "Henry" puts in the "baby Lincoln."

The circuit of the transformer primary winding is never broken, therefore no unsafe potential is developed in the secondary winding. The duration of the apparent short circuit is very small; practically no sparking will be evident. If more than 12 volts d.c. are used it may be a good idea to insert a small choke consisting of few turns of heavy wire on a core choke in the battery leads as shown in Fig. 1B in dotted lines.

As to procuring the various parts, an old commutator can be had for the asking at almost any electric repair shop. The only requisite is that it must have an even number of bars so as to divide up into an even

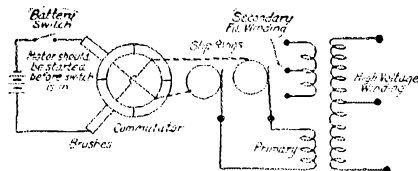

FIG. 3 DIAGRAM SHOWING CONNECTIONS TO A TRANSFORMER SUPPLYING BOTH PLATES AND FILAMENT CURRENT TO A TRANSMITTER OR A RECEIVER

This permits the use of filaments which will not operate directly on the battery.

number of sections. As an illustration let us say we got a 32 segment commutator from a G. E. ¼ h.p. d.c. motor and wanted to make a 4 section commutator out of it. We would divide 32 (number of segments) by 4 (number of sections we want) which would give us 8 bars per section that must

be jumpered as shown in the drawing only that this is done on the risers—the commutators instead of the front as shown.

Most motors of $\frac{1}{4}$ h.p. have a $\frac{1}{2}$ -inch shaft while at the commutator it is $\frac{9}{16}$ and back of that $\frac{5}{8}$. To get the shaft out of the commutator that has been sawed off the rest of the armature the commutator should be heated to around 200° F., and then the small end of the shaft pounded through; this is done with a light hammer, not a sledge, striking sharply.

The slip rings are turned out of brass or copper and have an inside diameter the same as that of the commutator (nine-sixteenths of an inch) so that a fibre rod can be pressed (not driven) through the whole arrangement. A hole is then drilled in the fibre to fit tightly on to the motor shaft. I believe that those who have no lathe would do well by having the commutator and slip rings fitted on the fibre and the hole for the motor shaft bored or drilled at a motor repair shop or machine shop as this whole part ought to run true for best results.

The brush holders for the slip rings may be made of $\frac{1}{16}$ " or $\frac{3}{32}$ " copper sheet.

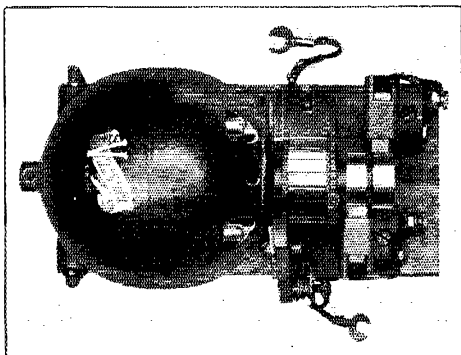

TOP VIEW OF THE COMMUTATOR DEVICE.

Nearest the motor is the commutator into which the battery current is fed as shown in Fig. 1B. The inter-connections between the commutator bars can be seen in this view or the end view. At the end of the motor shaft are the two slip rings from which the alternating current is drawn and fed to the transformer.

This is available at any copper and brass supply house and is easily bent into the shape shown in the drawing. The brush spring is made of a clock spring bent into a loop as shown in the drawing. This can be done by heating the end of the spring to a good red and then bending it around a nail with the aid of a pair of pliers. The spring is then hardened again by heating to redness and plunging into water. Particular care must be taken to heat the spring uniformly and hot enough without burning it.

The commutator brush holder can be made more simply than mine by using sheet copper. The spring tension against the brushes can well be made as shown since the construction is simple. The brush holder opening should not be quite as broad as the commutator and I believe not more than $\frac{1}{4}$ " wide.

The brush material and pig tails can be bought at a motor repair shop. It is cheaper to buy enough material for all the brushes and cut it up with a hack saw rather than to buy small brushes of the exact size wanted. The brushes are drilled and tapped for the 6-32 screw ends of the pig tails and these are screwed in tightly. If another type of pig tail is used it is easy to contrive a way of fastening, remembering that it is important to secure good electrical connections since this is a low voltage outfit and therefore all resistances must be kept down. For the same reason when buying the brushes try to secure the special low resistance graphite. If you cannot get that you can buy Ford generator brushes which will have to be sawed and sand-papered to size.

Because of the low voltage it is also advisable to wind the transformer primary with No. 10 wire or larger. A transformer whose core has a cross section of one square inch will require about 7 turns if the commutator is operating at 200 cycles. Knowing what secondary voltage is wanted one can figure the secondary turns by direct ratio.

An interesting test of the smoothness of the output was accidentally made one evening when the power supply went off so that our broadcast receiver could not work. I connected the 110-volt converter output to the B eliminator and we listened to the end of the program.

Horace A. Beale, Jr.

With the passing of Horace A. Beale, Jr., the League has lost a staunch friend and supporter.

Mr. Beale, who was a director of the League for over two years, was the owner of stations 3ZO, 3OI and 3XW located at Parkesburg, Penna. 3ZO was probably the largest and best equipped station that amateur radio has ever known.

As the result of a long illness, Mr. Beale became inactive in amateur matters and died on September 6, 1927, leaving many friends among the amateur fraternity.

The Helpful Audio Filter

WHEN one has reviewed all the different opinions it seems that there is no audio system that will suit everyone nor even an audio system that will suit the same person under all weather conditions and for all

are mutually exclusive and a sacrifice must be made in one to improve the other. Therefore filter systems for correcting defects appear to be reasonable since if the same correction were to be made in the transformer or loud speaker it would usually mean lower amplification per stage

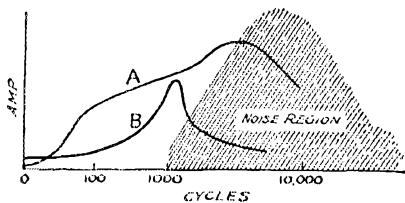

FIGURE 1. PURELY IMAGINARY AUDIO CURVES TO SHOW HOW A FILTER MAY SOMETIMES IMPROVE RECEPTION

varieties of signals or music. In the case of telegraphic signals one may for instance ordinarily wish to use an audio system having a curve like that of Figure 1A, so as to gain the full benefit of the "body" which

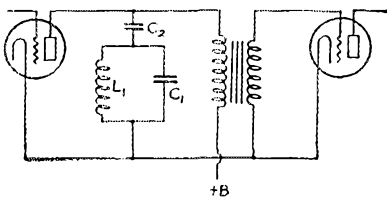

FIGURE 2. THE AUDIO REJECTOR SYSTEM DESCRIBED BY MR. HATRY

the lower tones lend to the signal, but on a night when interference is bad and static worse it may be a great relief to whittle this curve down to something like Figure 1B, so as to lose most of the horrible noises, even if the signal suffers in the process. This particular job can be done by the simple rejector system of Figure 2 which has been repeatedly described in this magazine by Mr. Hatry. As suggested in the label of Figure 2 such filters are largely a matter of cut and try, especially as the inductances of the transformers depend on the tubes and the tube voltages.

When it comes to the reception of a broader band of frequencies such as encountered in radio telephony the filter is even more useful, of this Frederick Dellenbaugh, Jr., says in a letter, "This is a perfectly standard way of correcting amplifier and loud speaker behavior. It is almost axiomatic that volume and quality

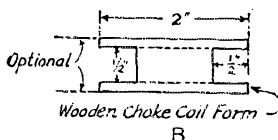
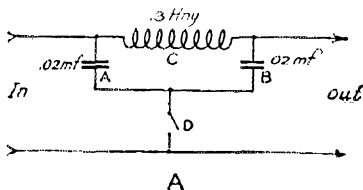
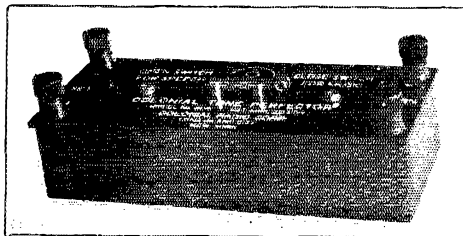

FIGURE 3. THE CIRCUIT AND WINDING FORM OF THE COLONIAL "TONE PERFECTOR"

The switch D is opened when speech only is to be received.

or greater damping and the loss of loudness is about the same."

Mr. Jack Ward of 6KC has furnished the details of one simple filter which are given in Figure 3. This device is of the low pass variety and is devised to correct amplifier systems having a bad bump in the vicinity of 3500 or 4000 cycles which (though it ordinarily helps out most loud speakers) is bad when one is working with



THE COLONIAL FILTER WHOSE CONSTANTS ARE GIVEN IN FIGURE 3

a good head set or a good loud speaker, especially if there is a noisy background since the noises are usually on the higher frequencies. It will be seen in the photograph of this particular filter and in the diagram of Figure 3A that a switch is provided to be opened when speech only is

being received. The effect of this is to cut the higher pitches off still further. Dr. Dellenbaugh suggests a modification

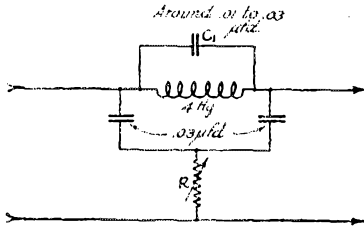

FIGURE 4. AN ADJUSTABLE LOUD SPEAKER FILTER SUGGESTED BY DELLENBAUGH

of this filter system which is shown in Figure 4. This figure differs slightly in its constant and in having two additions of which C_1 is to allow the higher frequencies to pass to some extent, the principle effect of the system then being to cut down frequencies around 2000 or 3000 cycles most of all, and to reduce those

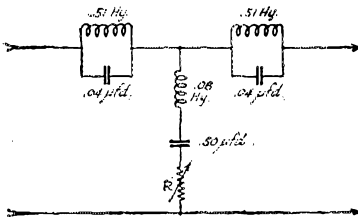

FIGURE 5. AN ADJUSTABLE BAND PASS FILTER

above these figures somewhat. The amount of this "somewhat" depends mainly upon the size of C_1 . The other addition is the resistance R which should have a range from 5000 to 50,000 ohms and controls the effectiveness of the system as a whole. This is a refinement of the switch D in Figure 3A. Dr. Dellenbaugh also suggests the filter system of Figure 5 which is a band elimination filter stopping everything between 500 and 3500 cycles. Since one does not wish to have complete elimination but only some depression the controlling resistance R is provided as before. Such a filter has characteristics the reverse of most of the loud speakers ordinarily used and it may therefore be used to correct them.

Where the problem is simply to cut down the high end of the curve one can frequently do the job with as simple a contraction as shown in Figure 6A which is taken from an article by H. J. Barton Chapel in *Amateur Wireless*. The part of

the system to the left of the dotted line will be recognized as being the usual thing in loud speaker filters designed to keep the current of the power tube out of the speaker. The group of condensers and the flexible leads are provided to give an adjustable cut-off on the high frequency end. This part of the device can also be built with a fan switch or with a comparatively large condenser in series with a resistance as shown in Figure 6B. These variable filters have the advantage over ordinary

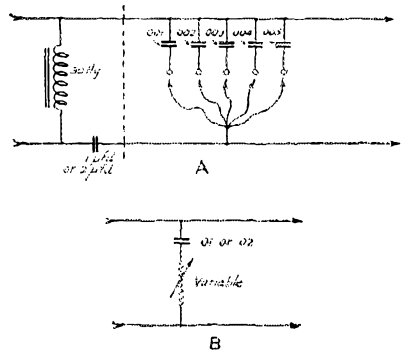

FIGURE 6. ADJUSTABLE FILTERS WHICH ALSO KEEP THE PLATE CURRENT FROM THE LOUD SPEAKER

fixed ones that it is easier to secure some sort of an agreement of the set with any loud speaker it may happen to be called upon to work with.

—R. S. K.

Southeastern Division—Florida Convention

January 13th - 14th, Hotel Alcazar, Miami, Florida.

LOOK at the above dates and put red circles on your calendar. The Miami Amateur Radio Club is sponsoring the convention and is planning a wonderful program.

Don Mix is expected to be the guest of honor. Director Dobbs has promised to be with us and Headquarters will send Treasurer Hebert to represent it.

All members of the Southeastern Division are cordially invited to attend—and hams from other parts of the country spending the winter in Florida. Write E. G. Watts, Jr., Secretary, 1024 S. W. 9th St., Miami, Fla., and tell him you will be there.

nu3CAB

THE ether stresser known as radio station 3CAB is located at 38°-56'-13" North and 77°-2'-2" West, a point known to the Post Office Department as 1311 Spring Road, N. W., Washington, D. C.

The call 3CAB comprizing the initials of the owner and operator, C. A. Briggs, was secured by the virtue of self-restraint. He put in his application for this call before it was issued and then waited patiently until its turn arrived.

The station was first put on the air in the spring of 1922. With the aid of a spark coil and a borrowed VT, signals were put out and reported by local stations as QSA. The expression "FB" had not come into use.

The first circuit used was the well named "sure-fire" arrangement. Frequently, the result of tightly coupled grid and plate coils, such a transmitter showed a versatility not suggested by the amount of wire in sight. Care had to be taken or else in addition to transmitting on two hundred meters, signals would be dispatched on 360 meters or thereabouts.

After two years the station was moved about half a mile to its present site. NAA could still be tuned in and heard plainly on 2650 meters. This was marveled at as the new site was surrounded by three systems of tin roofs bounding an enclosure laced over with a wonderful screening system of telephone wires. Viewed from the upper floor they seemed close enough together to walk on, and helped to explain the reason for the dividends of the Telephone Company during the last few years. The antenna hugged closely one corner of the triangle and extended upward into the metal maze.

Due to the inferiority complex arising from the surroundings aggravated by the appearance of BCL antennas nobler in equipment and competency for space above the housetops, the boundaries of the District of Columbia for a long time marked the active range of the station. However, ex-

perimenting was continuous. Finally, in the summer of 1926 the accumulation of equipment in preparation caused an attempt to be made to extend the range of the station. Results followed at once. It seemed that everyone reported the signals from a five watter. Improvements have continued and the present transmitter consists of a 203-A in a Hartley circuit.

The inductance consists of eleven turns of ¼-inch copper tubing. The tuning condenser is placed across the whole coil and transmission may be had in either the forty-or eighty-meter band by adjusting this condenser. It is not necessary to shift the clips on the inductance when changing from one band to the other. The key is located in the primary of the

plate transformer. The filament of the tube is supplied from a separate transformer.

As may be seen in the view of the station, the transmitter is mounted at the left end of the table on an extension to the table top. The pole transformer giving 1100 volts and the chemical rectifier may be seen underneath the same table. Directly below the table extension holding the tube are mounted the filament transformer, plate milliammeter, plate choke, grid leak and grid choke. This last choke is necessary because the leak goes from the grid to the filament center tap and is therefore in shunt to part of the helix. Two keys are provided at the right of the table. These are covered by a small elevated shelf protecting the keys from accidental closing and affording a place for messages disposed of. One key is a side contact key for regular use and the other is a straight key for visitors.

The Zeppelin type of voltage-feed Hertz antenna is used. The amount of space for erection being small, its dimensions are scant and it is necessary to use 16 turns of ¼-inch copper tubing in the feed circuit. The condenser is used in a series connection for operation in the 40-meter band and in

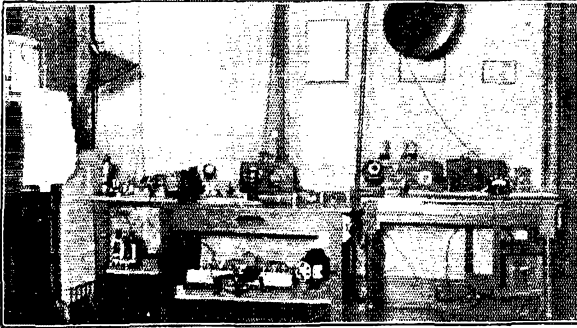

A VIEW OF THE STATION

The short-wave equipment is on the table to the left and the other table holds the broadcast set. The cardboard pockets holding the blank messages are at the left, attached to the lamp stand.

parallel to the inductance for the 80- and 20-meter bands.

Detuning the oscillator from the antenna will produce a steady note on a wind-driven antenna, when the signals could not be read while exact tuning was used. Although this

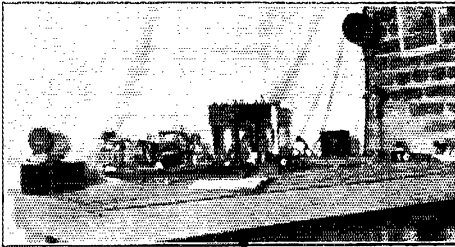

A CORNER OF THE LABORATORY

The particular set-up shown is for the calibration of a wavemeter. Measurements of resistance, capacity, inductance, voltage and current have been made in conjunction with various undertakings. The table now and then serves for a radio clinic and has been the operating table for removing appendices of sets or testing parts. The loud speaker mounted up in the corner furnishes entertainment when that is desired.

requires relatively tight coupling between the circuits, the results are excellent.

The receiver may be seen in the center of the operating table. A close-up is also shown. It is mounted on three legs which provide a desirable increase in the effective table area. The circuit is of the familiar regenerative type employing one variable condenser for tuning and one for the control of regeneration. Instead of employing plug-in coils for changing the range of the receiver, a fixed condenser is used and when shunted across the tuning condenser, it shifts the range from the forty- to the eighty-meter band. Clips are provided for this fixed unit and it may be connected in the circuit in very short order. Although the receiver is not a "thing of beauty", it works excellently which, after all, is what a receiver should do. It has a characteristic of all the tuners built at this station during the past few years, the detector tube is mounted up-side-down. This enables the shortest possible leads to be obtained in this circuit.

The chemical rectifier bears somewhat the same relation to the station as a flea to a dog—it receives a great deal of attention! First starting with 500 volts on the plate the twenty mule team product was used on twenty jars. The rehabilitation of aluminum and lead was a mussy process. Then the voltage was increased to 750, the jars to 30; and special solutions used. These did fairly well, but evidence for any conclusion could be selected. Some solutions turned brown,

some black, some stayed clear, and some of each color worked and some of each shade did not.

The voltage was then increased to 1100, the jars were decreased to 20, and in deference to the much advertised desirability of thrift, a new batch of solution, courageously diluted, was used.

Forthwith things began to happen. After sending "cq" the dial seemed full of responses, a "grand and glorious feeling". The innocent and quiet coils belied their looks and nipped brutally the skin of incautious fingers. This caused a revision in several ideas that the lesson was learned that the frequency of high frequency burns should be low.

On the table to the left of the one holding the transmitter is a broadcast receiver and when it is tuned to a local station, and the plate voltage of the transmitter is kept down to 550 volts, the transmitter does not affect the BCL set aitho both are using the same antenna. The BCL set is connected to the antenna thru the capacity of the change-over switch. Key clicks may be heard but these come entirely from the primary a.c. supply and are not affected whether the transmitting tube is in its socket or not.

The BCL set is connected to the loud-speaker shown above, and also to others upstairs and in the basement. The set is turned on or off by pushbuttons located at convenient points throughout the house. Flash light bulbs are placed in series with the tubes, each serving the quadruple pur-

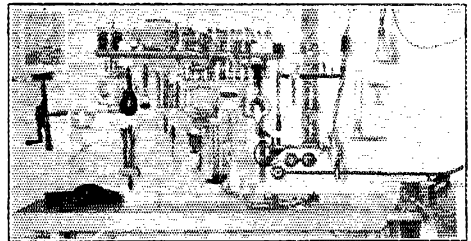

THIS WORK TABLE SHOWS A NEATNESS THAT MIGHT WELL BE COPIED BY MANY

Everything is within sight and reach which should be of a considerable help in getting work done. The "roving" lamp may be seen in the upper right hand corner.

pose of a rheostat, a light for a dial, a protection fuse for the tube filament and an indicator of trouble from poor and noisy contacts which might otherwise be erroneously recognized as static. The filament current is 0.20 instead of 0.25 amperes and the strength of signals does not seem to be materially reduced. The tubes seem to last indefinitely and the last one purchased cost

\$3.50. This gives an idea of how far in the past they were bought.

A "B" battery charging system is provided for the Edison Battery below the table. Plug connections for operating the "A" battery charger in the basement below are also at hand. One plug is used for operating the transmitter and all the charger and auxiliary devices such as soldering irons, etc. But one thing can be done at a time with the result that there are no accidents from crossing circuits.

The work shop of the station has several interesting features. By means of a simple arrangement, the light may be shifted to any position in a large area. The light is hooked over a wooden pole running from left to right and may be moved to any position along it. Eyelets are screwed into the ends of the pole and two wires which run at right angles to the wall, pass through the eyelets allowing the pole to be moved either away from or towards the wall. It is also possible to remove the light from the pole in a few seconds so that it may be used elsewhere.

A pilot light for the soldering iron plug reminds the worker not to leave the shop with the iron connected. Swinging service brackets are provided for soldering equipment and for drills.

The arrangement of the tools is the result of evolution, those being most frequently used at any position along the bench are placed nearest that point.

Supplies of screws, nuts and a quantity of parts are kept in glass jars. Just a small portion of these are shown in the photograph, the majority being on shelves not in the picture.

It is probable that this station has handled more messages without schedules than any other amateur station. This is due to special circumstances. Since the first of September, 1926, over a thousand messages have been handled, a negligible portion being the result of schedules. A considerable portion of the traffic has related to government business.

Organization has done what otherwise requires schedules. The owner is in one of the government departments. He has business dealings and friends in practically every one of the larger cities in the country. Attached to the lamp stand at the operator's left is a series of cardboard pockets. In these, addressed message blanks are placed according to localities. When good contact is made with a station, and there is any event of incident or business that can be advantageously handled by radio, it is placed on the partially filled blank and sent. In this way the other operator is given a live message which he can deliver.

Innumerable times the other operator has been able to phone the message and get a

reply at once. In this way a series of messages of special interest and potency are exchanged.

However, in addition to this traffic a large amount of other messages has been handled. A perusal of them is engrossing. Births and deaths are announced. A youngster in a distant city sends a message from his own station to his uncle. The uncle is profoundly moved, and in acknowledging it

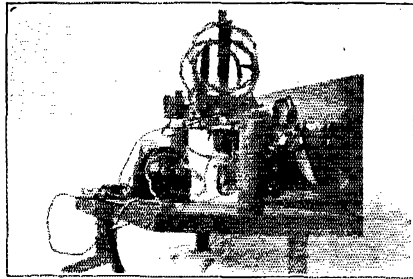

THE THREE-LEGGED RECEIVER

The plug-in fixed condenser may be seen just above the tuning condenser. The two-pronged plug is used to connect the set to the "A" battery circuit.

states that it was some time after he was born that the pony express started across the plains, and now, boys flash news about the country in an instant.

Many rubber-stamp messages are in the lot but they are often of importance. When they are from or to a person for the first time they should be given great weight. Most people, when they receive a radio message by phone are somewhat stunned, and their reply is generally rubber stamp in type, but the message is really very important under the circumstances. Some people are tremendously interested in receiving or sending a radio message, others are not. The persons may or may not be important, their interest is a matter of temperament.

Strays

A copy of the index to volume XI, the 1927 series of QST, was included with all membership copies of the Dec. 1927, issue. Newsstand readers, or members requiring additional copies, can obtain them from QST's Circulation Dept., 1711 Park St., Hartford, Conn., at 10c per copy, stamps acceptable.

Don't forget to send your card to International Contest Headquarters if you want to enter the Tests. Entries close February 1! No chance for U. S. or Canadian amateurs to win prizes or get the official test messages if they forget to enter before that date.

Rotten Bunk

By The Old Man

SAY, Warner, what's all this bunk about writing to our Senators to chase all the rest of the world out of radio so we amateurs shall have it all to ourselves? I copied something out of the air to this general effect the other night. Is it possible that some of us think that the results of the Washington Conference call for this sort of action?

I suppose because we shall have to shrink down some on our forty-meter wave in 1929, some of these hair-trigger young squirts think amateur radio is on the skids. Looks like it's time to send out for a small bottle of common sense. A few drops of it on the end of the Wouff Hong just before sticking the latter into the patient would do a heap of good.

I have followed what they pulled off in Washington fairly closely, and if I remember aright, there were about half a hundred separate and distinct nations that sat down to parcel out the wave-lengths. Also, if I remember aright, there were several interests besides amateurs that wanted a smell at the spectrum. There being only one spectrum, it was voted early in the proceedings that the amateurs could not have it all. I have a more or less misty impression that all but a very few of the nations had very definite ideas on this subject.

After all the fireworks had been set off at the Washington Conference, it turns out that our A.R.R.L. and the I.A.R.U. have secured international recognition for amateur radio, and in addition a band between 150 and 175 meters, another between 75 and 85 meters, another between 41 and 43 meters, another around 20 meters, another between 10 and 10.7 meters, and another down in the slums around 5 meters.

Pretty rotten, eh what? So frightful that we are asked to write to the United States Senate to scrap the whole works.

Say, if these young squirts had operated before the war, with spark coils and rotary gaps and with 200 meters as the top limit, they would not be writing their Senators. We used to think we were lucky, and we used to work DX. I don't suppose any of them ever heard of Paul Godley and those first transatlantic sigs at Ardrossan, Scotland, with Paul sitting up all night in a tent in the pouring rain. That was all done on 200 meters. I don't suppose they ever heard of Fred Schnell and Deloy in France, working back and forth every night for weeks on 110 meters? And of all the other things we did as we gradually slid down the wavelenghts, discovered the

new things and pointed them out to the Radio Corp.

Instead of writing to our Senators, we ought to be inquiring into what kind of osteopathy it was that you and Stewart were using on them down at Washington to get as much as you did. We've got enough frequencies to do everything that anybody can think of. The forty-band may be squeezed some, but it isn't all gone, and even if it were, there are all the others. The trouble with some of us is that we get the notion that the frequency we happen to be on is the only workable frequency in the spectrum.

Our eighty-meter band is the best band we have for all the working back and forth inside our own country. It doesn't skip much, and it works late into the morning and starts early in the afternoon. And the 150-band is just as good as it ever was. What's the use of writing the Senators about either one of these bands being worn smooth, when they have just as good mileage in them as they ever had?

And enough of the twenty-meter band is still there. Nobody has pinched it or put it in hock or fed it hooch. It's just as good as it ever was. And Final Authority said at the Radio Club the other night that the upper end of the new ten-meter band had indicated positively that it could do things that would make an old timer's mouth water. His language was considerably more elegant than mine and Radical's, but he had us all haired up just the same.

Now listen: If these nuts who want us to write to our Senators could be sent to Washington and made to go up against those hard-headed boys they call statesmen, it would be the best dose of medicine any of them ever had in all his life. Those folks in Washington have a way of making the proponent of an unreasonable measure look like the worst plugged nickle that ever came out of Chicago. I can imagine a committee of red-headed amateurs appearing before a Senate Committee and asking them to make reservations in the Radio Treaty because the amateur's forty-meter band had been pinched in a little at the waist, and then having one of those smart fellows from the Radio Supervisor's office point out that the 150-meter band, the 80-meter band, and the mutilated but still peppy 40-meter band, the 20-meter band, and the 5-meter band were still there—with a new band at 10 meters to boot. The result would be too

(Concluded on page 44)

Matching the Transmission Line to the Antenna

By Walter Van B. Roberts*

IF a transmission line for current feed is connected right into an antenna as in Fig. 1 without any transformer, not only will the range of the station be reduced, but meters placed in the transmission line can no longer be trusted to read the antenna current. Hence both for the sake of increased output and convenience it is worthwhile to give some attention to the method of connecting the line to the antenna.

Suppose the transmission line is made of two round wires of diameter d , with their centers D apart. It is easy to derive from first principles the formula for the characteristic impedance of the line—that is, the impedance of an infinite length of the line. The formula is:

$$\text{Characteristic impedance} = 276 \log_{10} \frac{2D}{d}$$

very approximately.

Next suppose the antenna is a plain open oscillator—a straight wire a little less than half a wavelength long—say about 44% of a wavelength long. (See *QST* p. 16, October, 1926). The radiation resistance of such a wire working at its fundamental

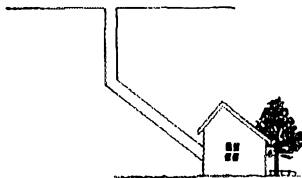

FIGURE 1. THE TYPE OF ANTENNA UNDER DISCUSSION

If used in the simple form shown it is operating with various currents and voltages along the line and the current in the top cannot be foretold with certainty from a meter in the line.

is in the neighborhood of 70 ohms, whatever the wavelength. Hence the total resistance of the antenna will be probably somewhat less than 100 ohms.

Now the problem is to match the transmission line whose characteristic resistance we will call R_L , to the antenna whose total resistance we will call R_A . The first thought would be to choose D and d in building the line such that the formula given above makes R_L come out about 100 ohms, so as to match R_A . But in order to do this it will be found that the wires would have to

be kept too close together to allow maintaining an even spacing. Hence it is better to build the line with a convenient spacing, calculate R_L , and then interpose a step-down transformer between the line and the antenna.

A simple and highly efficient transformer (it is not the usual sort of transformer with

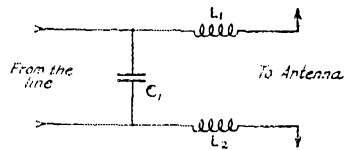

FIGURE 2. A TYPE OF SIMPLE NETWORK WHICH MAYBE USED AS A TRANSFORMER TO MATCH THE IMPEDANCE OF THE ANTENNA TO THAT OF THE R. F. TRANSMISSION LINE.

The two coils L_1 and L_2 may conveniently be halves of the same cylindrical winding which has been cut at the center to provide antenna terminals and across the outer ends of which the r. f. line and the condenser C_1 is connected. This is the output transformer and goes at the antenna end of the line.

primary and secondary windings, but much better for the particular wavelength for which it is designed) is shown in Fig. 2. The transmission line is to be connected to the left hand terminals and the antenna is cut in the middle and connected to the right hand terminals. The capacity of the con-

denser should be $\frac{1}{2\pi f R_L} \sqrt{\frac{R_L - R_A}{R_A}}$ farads,

where f is measured in cycles per second and R in ohms.

The coils are preferably equal, and if coupled at all should preferably be so coupled that if the condenser were short circuited and the inductance between the right hand terminals then measured, the coupling would increase the total inductance. This total inductance

so measured should be $\frac{R_L - R_A}{2\pi f} \sqrt{\frac{R_A}{R_L - R_A}}$

Henrys

so that if the two inductances are equal and are not coupled to each other, the inductance of each would be half of the above value.

The input end of the line can be coupled to the oscillation circuit as shown in Fig.

1. As has been noted repeatedly in *QST* it is decidedly preferable to couple the line rather than to tap the coil P . The same statement holds good for single-wire lines.—Tech. Ed.

*Engineer, Radio Corporation of America, 155 Hodge Road, Princeton, New Jersey.

3 by a coil of any convenient size, in series with a condenser of proper capacity to tune out the inductance at the frequency used.

Fig. 1 shows the complete set-up. Any desired oscillator or amplifier may be used. The coupling coil L_3 is shown split with the condenser C_3 in the middle for the sake of

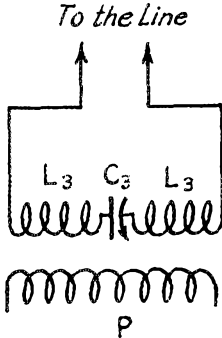

FIGURE 3. THE INPUT TRANSFORMER FEEDING THE LINE

P is the inductance of the transmitter oscillator or the output coil of the amplifier if one is used. The circuit with which it operates does not matter. L_3 is any convenient coil split at the center by the tuning condenser C_3 . The coil and condenser must be able to tune to the working wave when the line is short circuited.

symmetry. The transformer L_1, L_2, C_1 is mounted on a small board held up by the two halves of the antenna.

AN EXAMPLE

For the sake of illustration suppose the wavelength is to be 40 meters then frequency $f = 7,500,000$ cycles per sec. The overall length of the antenna will be about 44% of 40 meters or 17.6 meters. Let us suppose the antenna is a single wire of small diameter so that the total resistance of the antenna, R_A , is about 100 ohms. Suppose also that the transmission line is made of wire one millimeter in diameter, spaced 50 mms. apart. Then by formula,

$$R_L = 276 \log_{10} \frac{100}{1} = 552 \text{ ohms}$$

Knowing $R_A = 100$ and $R_L = 552$ the formula gives us

$$C_3 = \frac{1}{2\pi(7,500,000)(552)} \sqrt{\frac{552-100}{100}} = 81.7 \times 10^{-12}$$

Farads = 81.7 μ f. L_1 and L_2 will have a total inductance of

$$\frac{552-100}{2\pi(7,500,000)} \sqrt{\frac{100}{552-100}} = 4.5 \times 10^{-6} \text{ henrys or } 4.5 \text{ } \mu\text{hy.}$$

We will suppose that L_1 and L_2 are the two halves of a single straight cylindrical coil which is cut in the middle to allow the insertion of the antenna as shown in Fig. 4. Then this coil before cutting

would have 4.5 microhenrys inductance. (The coil should be firmly mounted before cutting so that the halves won't move.)

Coil L_3 may be of any convenient size, the only requirement being that L_3 and C_3 are related by the formula

$$f = \frac{1}{2\pi\sqrt{L_3 C_3}}$$

For definiteness, suppose $L_3 = 10$ microhenrys = 10^{-6} henrys. Then we must have

$$7,500,000 = \frac{1}{2\pi\sqrt{10^{-6} C_3}}$$

whence $C_3 = 44.5 \times 10^{-12}$ farads approximately, or 44.5 micromicrofarads.

After the antenna and transformer and transmission line and coupling device L_1, L_2, C_1 have been constructed according to the foregoing formulae, it should be only necessary to vary the oscillator frequency and coupling to the transmission line to obtain maximum output. If everything is built correctly a meter in any part of the line will

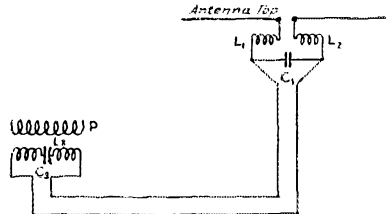

FIG. 4

FIGURE 4. THE COMPLETE SYSTEM

The output transformer L_1, L_2, C_2 is mounted so as to be supported by the antenna while the input transformer is naturally located in the station. The line may be several hundred feet long without noticeable harm.

read proportionately with the antenna current. The actual antenna current will however, be larger than the line current by a constant factor because the step-down transformer increases the current in the

$$\text{ratio } \sqrt{\frac{R_L}{R_A}}$$

It is particularly pleasing to note that several hundred feet of transmission line may be used without any noticeable loss of antenna current.

Rotten Bunk

(Continued from page 52)

painful to dwell upon. 'Tis better that we draw the veil.

Better get out the old Wouff Hong, son, and send down to the store and get a few drops of common sense extract, and proceed as per directions.

The Unimportance of Short Leads

By L. W. Hatry*

SHORT-LEADS have their place in set design. However, we often use leads *too short for best results, convenience or appearance.* The first of these things is italicized because there seems to be a strong belief that leads cannot be too short. In the italicized words we have a partial explanation of the fact that often an experimental layout with long leads outperforms a supposedly "decent" duplicate assembly with short ones. (Of course, there are plenty of set-makers who use long leads and fail in both best results and convenience.)

The conditions under which to judge the need for shortness of connections can be settled by answering this question "*Can the leads be harmful?*"

The answer to the question will be, "Yes," when the leads add excessive R, L or C. We can guess closely at R and the rest, (they are interlocking effects as usual) if we consider the placing of the connections as: (1) Leads within a tuned r.f. circuit; (2) r.f. leads outside a tuned circuit, and (3) other than r.f. wiring.

Fig. 1 shows a tuned circuit. The coil and condenser are shown with terminals which we may pretend are attached in the



FIG. 1. TUNED CIRCUIT FOR DISCUSSION

Because the coil L and the condenser C are most talked about the builder is inclined to think that the wire between them are to be made as inconsequential as possible but shortening them too much is quite likely to make trouble instead of curing it.

usual way. The coil and condenser are drawn heavily to make sharp the distinction from the leads which are drawn lightly. Within this tuned circuit the current at resonant frequency oscillates back and forth, suffering no opposition save from the resistance of the circuit. Consequently if we have gone to considerable trouble to produce a good coil and condenser it is important not to harm that achievement by using German silver leads or by adding resistance in some other fashion. We can most effectively add resistance to the tuned circuit by placing L so close to C (while trying to get short leads!) that eddy currents are set up in the plates of C, or by getting L too close to

any other mass of metal. This exact method is used in more than one receiver to prevent oscillation on the lower broadcast wavelengths. The coil L ought to be kept

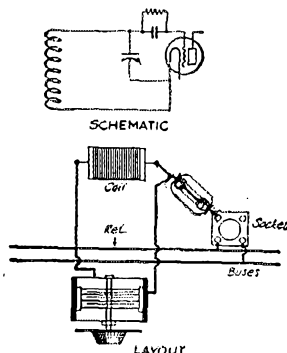

FIG. 2. A TYPICAL LAYOUT THAT DID NOT PROVE GOOD

Note that the part of the filament bus marked "Ret." is in the tuned circuit therefore has an r.f. drop along it. This makes it impossible to have both the filaments and the condenser at ground voltage. Note also the loop made by the circuit.

at least 2/3 of its own diameter distant from the large metal areas. The actual resistance of copper leads is not smaller in gage than the coil wire is of no importance in the usual hookup.

Leads in a tuned circuit can produce several effects by adding capacity and inductance. If close together and insulated the leads can add resistance by becoming a poor condenser but uninsulated leads can seldom do worse than add "good" capacity which builds up the circuit minimum. As no length of connection within reason can do worse, why worry? In a multi-stage tuned r.f. job long leads can couple by capacity or inductance but even these things are unlikely to be important compared to coil-to-coil coupling. Not until the set has become fully neutralized are these effects the largest ones. In the usual regenerative set, hand-capacity will result from a large field due to long tuned-circuit leads, which may seem short. In Fig. 2 the heavily drawn leads seemed short but they produced a single large turn that had a large field and with which the hand interfered although the variable condenser itself was grounded properly as touching the finger on the shaft proved. Not even a metal dial will always cure a case like 2.

*Radio Department, Hartford Times, Hartford, Conn.

I ran the leads in this set directly from the coil to the condenser, behind the condenser, and placed the leads close to each other to restrict their area of operation.

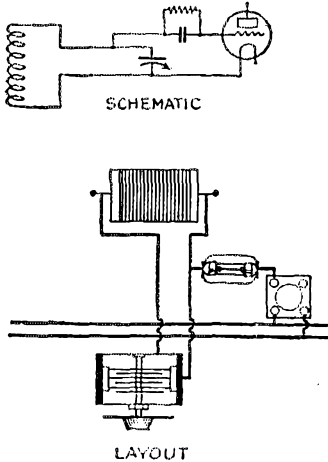

FIG. 3. THE CIRCUIT REVISED TO CURE THE DIFFICULTY MENTIONED IN FIG. 2

The hand effect was now eliminated, even on 40 and 20 meters. The revised version is in Fig. 3.

In a tuned r.f. circuit the leads connecting the coil and condenser should be direct but in the average plug-in-coil 20-, 40- and 80-meter receiver are practically never too long nor can they reasonably be made so.

R.f. leads outside the tuned circuit are unimportant as long as the concentrated inductance capacity in the condenser are much larger than the distributed L and C of the outside leads; all of which usually is the case at 20, 40 and 80 meters. In fact

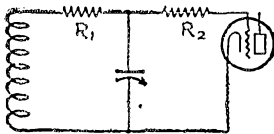

FIG. 4. THE CURRENT IN THE TUNED CIRCUIT IS LARGE AND A RESISTANCE AT R-1 WOULD BE DEADLY BUT THE CURRENT TO THE GRID IS SMALL AND RESISTANCE AT R-2 DOES LITTLE HARM UNTIL IT HAS BECOME QUITE HIGH

the G to F capacity of the tube used generally is far greater than any practical grid lead would have unless one actually lays the grid lead along a filament lead or a shield. About the only thing a long grid-lead could add is resistance. This resistance

can be either actual resistance or a poor condenser effect, the latter being impossible if air insulation serves between related leads. As the losses are determined by the simple formula I^2R and as the r.f. grid control is largely by voltage with very little current flowing to the grid added loss do not occur importantly with resistances less than 200 ohms, as experiment will prove. See Fig. 4. As the G to F capacity of the tube and the grid-lead to filament-lead capacity can become an important part of the tuned-circuit capacity (see Fig. 5) when the variable condenser capacity is low (so much so as to carry over half the r.f. current within the tuned circuit) a short lead may become important at some dial settings. This fact may account partly for the observation made by myself and some others that a small grid-condenser (which helps to reduce the importance of lead and tube capacity) is of advantage. Experiment shows that this is not a complete explanation.

The inductance of leads may come into account at very high frequencies. As has been mentioned in other articles in the magazine, a straight wire can act as an r.f. choke.

A more practical discussion may be based on the well known circuit of Fig. 6. The outside r.f. leads are drawn heavily and

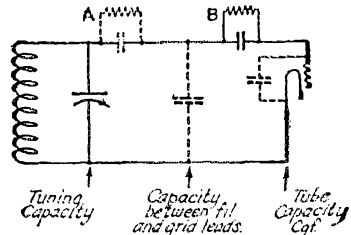

FIG. 5. WHERE THE TUNING CAPACITY IS SMALL THE OTHER CAPACITIES MAY BECOME IMPORTANT

This is one reason why it is not advisable to make the tuning capacity very small, for instance less than 25 micromicrofarads. In the diagram if one puts the grid leak and condenser at A the effect may be quite different from that obtained at B, therefore its location may be important. This is quite noticeable at 5 meters.

are numbered. The lead 1 may have important capacity relations to leads 3, 5 or 6. The results in any case are "dead-spots" (due to antenna resonance) even with P and S loosely coupled. Lead 3 is active to 4, 5 and 6 but the effects to 4 largely may be ignored. The effects to 5 and 6 result in excessive tuning effect from the regeneration control, or in freak tickler sizes, usually extra small. Little else is likely to result importantly. My prefer-

able arrangement for 4 is not to have this filament lead included in the tuned circuit for there its resistance (not its inductance) can provide an r.f. across its disproportionate to its size. The current within the tuned circuit is at maximum and across

I like bare bus-wire because it is rigid and can be soldered to at any point. Under appearance we may consider sub-panel work (which knocks repair convenience into the rough), square-cornered wiring, spaghetti, etcetera, all of which can be used harmlessly.

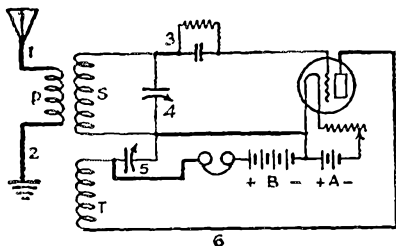

FIG. 6. THE RADIO FREQUENCY CIRCUITS, EXCEPTING THE SECONDARY CIRCUIT, ARE HERE NUMBERED FOR DISCUSSION OF THEIR EFFECTS ON EACH OTHER

any unit or F in it the voltage drop E is equal to IR . The current *outside* the tuned circuit should be small so that an E equal to the product of this smaller I with R will be less, so that the voltage above reference of the rotary condenser plates will be the practical minimum. The correct connection is shown in Fig. 3.

The d.c. circuit, the filament wiring, of course can be of any length and may be placed any desirable way. The wire need only be sufficiently large to carry the current since excessive "A" voltage, which we reduce with rheostat, is normal practice. If we carefully terminate our r.f. circuits at the socket terminal F as suggested in Fig. 3 then the filament circuit carried d.c. only and its length is unimportant.

The a.f. circuits are those of the phones and B-battery and whatever portion of the A line is included from B minus. These in general in a small one- or two-tube set may be as long or as indifferently arranged as desired. Where in a det.-one-stage job we meet with hand-capacity to the headset the cure is generally a large by-pass condenser across the amplifier B-battery from "B plus" to the detector grid-return whether A plus or minus.

The cord of the headset provides a relatively large bypass capacity so that its only r.f. has to come from the drop across the resistance of the B's which resistance is common to detector and amplifier alike. By shorting this resistance with a very low reactance (1 μ f. or as much as necessary) the drop "livening" the headset is reduced.

In general then it is not *short* leads that are so necessary as the *intelligent placing* of leads.

I have not yet seriously touched on convenience or appearance. Under convenience one example serves to illustrate:

Admiral Bullard Dies

REAR Admiral Wm. H. G. Bullard, U. S. N., retired, chairman of the Federal Radio Commission, died suddenly in Washington on November 24th, aged nearly 61. His death occurred on the final day but one of the International Radiotelegraph Conference, where he was also an American delegate. He was the second member of the Commission to pass on, Colonel Dillon having preceded him in September.

Admiral Bullard was long connected with American radio. He was the first commandant at NAA and the first Director of Naval Communications, serving in that office from 1912 to 1916. After duty at sea he again became D.N.C. from 1919 to 1921. He was instrumental in the formation of the Radio Corporation of America as an all-American communications agency which would retain control of American communications within this country.

It is fitting at this point to quote an Associated Press despatch from Washington: "Admiral Bullard was a great friend of the amateur operators and guarded their communication hand with zealous care. To them he attributed much of the progress of radio in America and he often expressed the belief that they would keep this country in the foreground of radio development."

Vale!

—K. B. W.

Strays

Readers are requested to make the following correction in the 1927 Index, which was published as a supplement to December *QST*. Under the head "Amateur Radio Stations" a number of references to page numbers and issues incorrectly appear as a group at the end. These references are to editorials bearing upon "Amateur Regulations & Legislation" and belong in the second line of the following section, which bears that title.

This index has been furnished without cost to all member-subscribers. Others may obtain a copy upon request.

Experimenters' Section Report

THE 5-meter test reports have come in very slowly indeed and thru sickness of two of the men prominent in the test it has become unavoidable to carry the whole report over another month. It must be realized that this is being written at the last possible moment for this issue—which is to say, December 1st.

STANDARD FREQUENCY TRANSMITTERS

The standard frequencies from 9XL will be continued. We were considerably disturbed when a change of station management took place but it seems now that Chief Operator McCartney and his crew will be able to continue as before with these transmissions and station WCCO-9XL-9WI will continue to occupy its wholly unique position of combined broadcast station, standard frequency station and amateur station.

There is also a good chance that another station will be added before the winter is over.

Meanwhile it is suggested that the acknowledgments of the work of the station be made on the standard blanks supplied by the "X"-section or in the complete manner shown by the following letter.

O.W.L. Radio Station nu-3FC,
266 Queensdale Ave.,
Toronto, 6, Oct. 14th, 1927.

S.F. Radio Station nu-9XL.
Anoka, Minn., U. S. A.
Dear OM's:

Your Standard Frequency transmission to-night was followed without any trouble from the time I reached the set here at 10:30 E.S.T. until 11:50 when you were on C.C. at 42.5 meters with your QST. I afterwards heard the music modulation, but owing to some rather severe fading at that time, the music was not all that could be desired.

At 10:30 on 5.70 Mc. signals were steady R7. At 10:47 on 6.50 Mc. signals were steady R7 to R8. At 10:55 on 7.00 Mc. signals were steady R7 to R8. At 11:10 on 7.50 Mc. signals were steady R7 to R8. At 11:20 on 8.00 Mc. signals were steady R6 to R7. At 11:30 on 8.50 Mc. signals were R7 and still steady except at times a slight tremor was noted. At 11:42 on cx. control on 42.5 meters signals were R6 to R7 with a very pure note. The tremor spoken of before was also noted at this time and fading began to be apparent soon after the QST was finished. Signals faded from R7 to R4 at fairly regular intervals of about one minute. The music modulation seemed to fade to a greater extent than the c.w. appeared to do, but perhaps that is a fallacy of my ear. When fading was at its worst, distortion was also quite noticeable, in fact the two seemed to peak together.

I much prefer the tone modulation now used on these S.F. transmissions, to the pure CW used before, although I do think that the pure CW allowed a greater percent of accuracy on attaining the true zero beat in the receiver. The receiver used, by the way, was an ordinary 3 coil affair with detector and one A.F. tube. The antenna 15 feet high and 30 feet long all told including lead-in.

I want to congratulate you all on your very nice work and your exceedingly good signal strength as usual. Keep up the good work, and more power to you!!!

Many thanks for the timely checks.
E. C. Thompson, Assist. ACM, Ontario, Central District.

PROBLEM G-13 IS ALIVE

The following letter and circular are a splendid illustration of the way an active problem should be handled.

Fairmont, Minn.

Experimenters' Section,
A.R.R.L.

You have at intervals sent me schedules of 5-meter tests, etc. Now I am interested in these things and like to know what is going on but it is a waste of "X" section resources to send that kind of stuff to me as I make no use of it that will ever give the Section returns. I am working on problem G-13 to avoid static and other interference and devote all the time I have to spare on such work to that problem.

I do not know if the headquarters gang know that any of the G-13 men are still alive or not but as a matter of fact there are several quite active "static dodgers" hammering away at the so-called Tyzzer System of radio.

H. R. Starkey, 153 Cowan Ave., Toronto 3, Ont., Canada, acts as a sort of correspondence clearing agent for the gang and is building a receiver for the tests we expect to run.

H. B. Bennet of Rockford, Ill., is also building a receiving set. Krebs expects to do both xmitting and receiving. He is a navy yard man and has access to plenty of equipment.

G. E. Gustafson of Mt. Prospect, Ill., and operator at WJAZ is also expecting to put an xmitter on. His old 9XN equipment is available. Think he is not an "X" section member. There are also a few others interested. I am expecting to put on some tests myself before long. How long depends on amount of time I can spare and number of bugs I have to eliminate. Have xmitter ("one UX-210 power") and receiver built and have tested over a few blocks with very good results but have found several of the before mentioned bugs which have to be picked before trying for longer distance and serviceability data. Expect to run test over a distance of about 120 miles if possible and over a period of time long enough to get data on the system's possibilities for amateur work.

If you have any data along this line or new G-13 men on the list let me know. Also Mr. Tyzzer's present address if available, also where any information can be had on single side band transmission as it seems to some of us that it could be worked in on the Tyzzer system to advantage.

J. A. Nightingale, Radio 9ABE, 223 S. Main St., Fairmont, Minn.

(We do not know Mr. Tyzzer's address, having been unable to reach him by mail for some months. Information will be appreciated.)

A STARKEY BULLETIN

The following is a sample of the sort of mimeographed material sent out by Mr. Starkey:

153 Cowan Ave., Toronto, Ont.,
Canada.

"Some want circuits, so here are a couple—rather crude but giving the basic circuits without new ideas. If you fellows will send in your circuit plans I'll devote the next bulletin to them so that we may all pick out the ideas we like best in each. Please send complete details, including aeriels, power supply, and keying with description of apparatus.

The first circuit, using Heising modulation, needs two similar tubes. The 2nd, using grid modulation, could use a smaller tube for the lower frequency.

H. E. Bennett, 1515 Burton St., Rockford, Ill., has come in for the receiving end.

Krebs, 3AEA, says he is busy building two navy transmitters, but that when he does get started it won't take him long to get on the air, as he has all the necessary "junk".

Gustafson, WJAZ, says "Will try to make some tests next week." Fast work!

Nightingale—too busy to report. "I haven't done a thing but draw and redraw my circuit plans and 'cuss' the railroad for non-arrival of my material which is following me to Canada by freight."

We seem generally agreed on the 3.5-4 megacycle band, at least until we can put an amplifier between

be necessary. Who will be first to shoot an amateur picture across the country?

Some Special Uses of the UX-222

By Harold P. Westman*

THE object of this work was to obtain a circuit arrangement whereby with a tetrode and a single coil and condenser not requiring any taps off either, it would be possible to generate oscillations dependent upon the constants of the coil and condenser which could be used for a laboratory oscillator. An indicator of resonance having characteristics closely approaching those of the grid meter in an oscillating circuit employing a triode was also required in order to make the instrument capable of competing with such a driver. The output of the oscillator was not considered as a matter of prime importance as it was not to be used where high outputs were needed.

Figure 1 shows a circuit that will oscil-

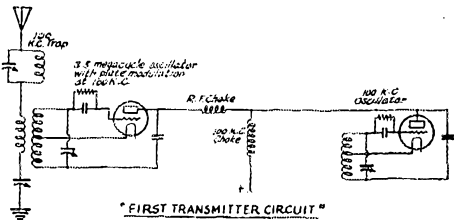

the transmitter and the antenna to pass only one sideband. Are we also agreed on keying in the high frequency to start with? Later, when radiating only one sideband, it will make no difference where we have the key and we can hope to use a modulation frequency in the B.C. band with B.C. receivers for I.F. amplifiers.

Don't be afraid to report no progress. No report—no bulletin! WE've got to keep in touch with each other if we want to accomplish anything. If you find it possible—write to all the active men as well.

Your Secretary,
Healdon R. Starkey.

CONCERNING TELEVISION

There seem to be experimental possibilities in the Cooley "rayfoto" method of transmitting pictures. The details are

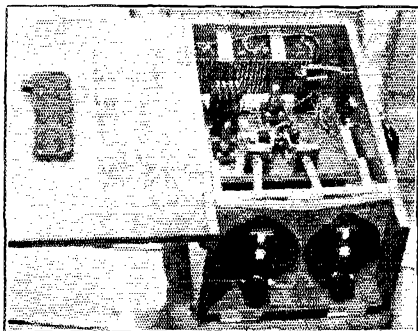

A 5-METER RECEIVER USED IN THE WGY TESTS

Note the general resemblance to the sets used by this section in some of our tests.

gradually coming forth in a series of articles in Radio Broadcast. Unfortunately the series is getting at the principle last, instead of first so that a bit of study will

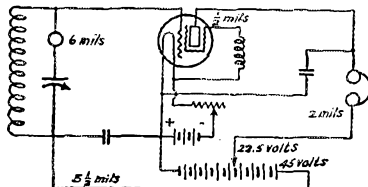

FIG. 1. THE B BATTERY TAP IN THIS CIRCUIT IS NOT CRITICAL AND THE TUBE WILL OSCILLATE WITH BOTH CLIPS AT +45

The currents change about 5% between the oscillating and non-oscillating condition in all cases.

late. It is not known just why this circuit should be able to oscillate as there seems to be no definite feedback paths in the external wiring. It is quite possible that there may be some sort of coupling or an unbalanced condition within the tube itself which accounts for this action. It is, perhaps, due to the "reverse action" of the inner grid current (I_{c1}). The current in this circuit increases as the potential on the outer grid becomes more negative. This is due to the fact that when the outer grid becomes more negative it repels some of the electrons that would normally pass through it and these are then forced back to the inner grid which is positive in respect to both the outer grid and the filament. The plate current decreases as the outer grid becomes more negative.

As the outer grid is at a radio frequency potential above that of the filament, it cannot be connected back to the filament directly. To prove that the radio frequency choke was not acting as an inductance, causing the three inner electrodes to act

*Asst. Technical Editor.

as a triode connected in an Armstrong circuit, the choke was substituted for with a resistor of 8,000 ohms. The circuit still continued to oscillate at approximately the same wavelength though with a decided drop in output. The resistor was of the coated glass filament type commonly used as grid leaks, therefore having a negligible inductance.

Neither the voltage on the inner grid nor the plate was critical and both could be at the same potential. That the oscillating energy in the circuit was but a small part

as this did not allow these conditions to be indicated on a meter. The meter in the tuned circuit gave the greatest indica-

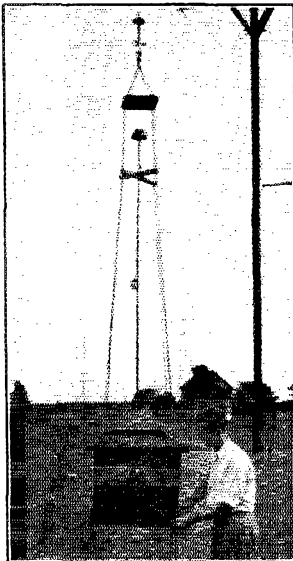

A 5-METER TRANSMITTER USED IN TESTS FROM WGY, OR RATHER FROM ONE OF THE MANY 2X-STATIONS AT THAT TEST-POINT.

of the total energy was apparent when oscillations were stopped. The currents in all the circuits (not counting filament heating current) increased by about five per cent over their values when oscillations were being generated. The current in the inner grid circuit was approximately 5.5 mils; in the plate circuit, 2 mils, and in the outer grid circuit, 1/2 mil. The radio frequency current in the tuned circuit was dependent upon the C/L ratio and is therefore meaningless unless one knows not only the C and L values but also the amount of resistance in the circuit.

The fact that no large current changes took place when the oscillations started and stopped made this circuit unsuitable

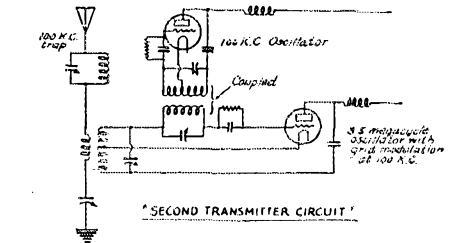

tion but as this was sluggish in action (being a thermogalvanometer) it was by no means a competitor to the sharp, rapid readings that are characteristic of the grid meter on an oscillator employing a triode.

Another circuit that can be made to oscillate is shown in Figure 2. Suppose we were to leave out the outer grid which would then give us a triode. The circuit would not oscillate because while there would be plenty of power available to be fed from the plate to the grid circuit, the phase relation between the two circuits would not be such that the circuit would oscillate. The circuits would not be "pulling together" but would be "bucking" each other. Now if we were able to make either the plate current increase when the grid became more negative or else reverse the plate current and still have it decrease when the grid became more negative, we would have reversed the phase relations and this type of coupling would allow the circuit to oscillate. The use of the extra grid allows one of these things to be accomplished; we can reverse the direction of flow of the plate current.

Let's go back to the triode again. Suppose the grid is made positive in respect not only to the filament but also to the

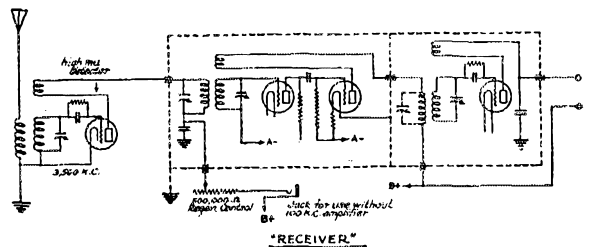

plate. That is, the grid is at a higher positive potential than is the plate. Electrons emitted by the filament will be at-

tracted toward the grid and will attain velocities that are quite high due to the grid being located so close to the filament and and there being such a large difference of

critical and the circuit will not oscillate for any value which gives a reverse plate current but only for values over a limited range. In the particular set-up used, the plate voltage was 56 and the outer grid voltage was 95. The inner grid was returned to filament minus.

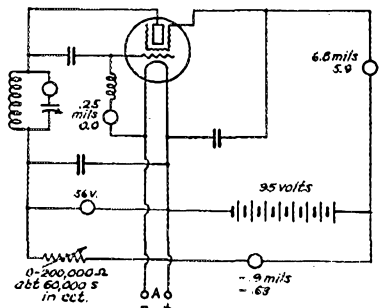

FIG. 2. THE LOWER NUMBERS ARE FOR THE NON-OSCILLATING CONDITION. THE UPPER ONES FOR THE OSCILLATING CONDITION

In going from an oscillating to a non-oscillating condition, the currents in the various circuit made these changes; inner grid (grid leak circuit current) from 1/4 mil to zero; outer grid, from 6.8 mils to 5.9 mils and plate current from .9 to .63 mils (in reverse direction). As the changes in the currents in these circuits did not compare favorably with the change that is had in the grid circuit of a triode oscillator, this circuit was also considered as being impractical for the purpose.

potential between the electrodes. Not all of these electrons are going to be caught by the grid and some, due to their high velocities, are going to slip through its mesh and travel on to the plate. Now when the speed or velocity of the electron is high enough, it may, when it impinges itself upon a piece of metal, liberate from that metal, one or more electrons. These electrons are logically called secondary electrons and the phenomenon, secondary emission. Now, the velocity of the secondary electrons is comparatively low and they will be attracted to the grid which is at a higher positive potential than the plate from which they originated. If the velocity of the initial or primary electrons be great enough to dislodge more than one secondary electron, it is obvious that the plate current will be in a reverse direction to the usual flow. While secondary emission occurs in the usual circuits in which triodes are operated, the plate is always the electrode of the highest positive potential and the secondary electrons are attracted back to the electrode from whence they originate making a net gain or loss of zero as far as this secondary emission is concerned.

To get back to Figure 2. If the potentials applied to the plate and outer grid are properly chosen, the secondary emission can be made large enough to cause the plate current to be reversed and the circuit will oscillate. These voltages must be quite close to the necessary values or no oscillations will be generated. The potential on the outer grid may be left constant and by means of a variable resistor in the lead to the plate, the voltage applied to that electrode may be varied until the correct value is found. This value is

Re: The International Test

THE first International Contest held last May was so successful and so enthusiastically received that it is being followed by another somewhat similar contest which is scheduled to open February 6 next. Complete details were given in December QST so that they might be distributed to the most remote parts of the world before the contest opens. Such contests have a number of important objectives. They promote international fellowship and goodwill. They create opportunities for making new records. The coming tests in addition offer a chance for you to win valuable apparatus prizes at the same time you engage in two weeks of rare international sport. Stations at each end of an international contact must help each other in turn with the test messages to add equally to their scores. New friendships will be cemented through the teamwork thus brought about. Every amateur station in the world is invited to participate.

Attention is called to the fact that entries are required of U. S. and Canadian contestants. The closing date for entries is midnight of February 1, 1928. Before you get next QST the chance to enter in the tests and to become eligible for a prize award will have gone. A QSL-entry-card mailed today will put you in line to receive a set of official test messages and a serial number assignment which will be necessary if you expect to participate. To delay will mean that you may later be denied the opportunity to enter. Rule 10 (see p. 33 Dec. 1927 QST) will be rigidly enforced as will all the other rules of the contest. Mail that entry card today.

We already hear of plans being made in

(Continued on page 68)



I.A.R.U. NEWS

PERHAPS you have had some inquiries relating to a short-wave station signing xoa5MA. If so, you may find the following information to be of interest.

"I have been intensely interested in amateur radio for many years and have been in communication from Australia (oa5MA) with many foreign countries. I was finally overtaken with a desire to meet these fellow hams personally and saw an opportunity of satisfying this desire by signing on the six-masted American barquentine, *E. R. Sterling*, the largest of her kind in the world. She was loaded with wheat and bound for Europe via Cape Horn.

"Accordingly, April 16th found me looking over the rail watching Australia become just a faded blue mass on the horizon.

"Of course, I had some short-wave equipment aboard with me. The transmitter consisted of a 210 in a Meissner circuit with three 201-As for modulators. Plate power was obtained from an Esco dynamotor running off a 6-volt storage battery. The output of the machine was rated at 65

short-waves. Many others were tried and some brought back quite good reports on signal strength. However, none approached the big antenna in the steadiness of the wave during rough weather, and I'm about to tell you that we met some rough weather before we again reached port.

"The receiver was a three coil affair with plug-in coils and a switching arrange-

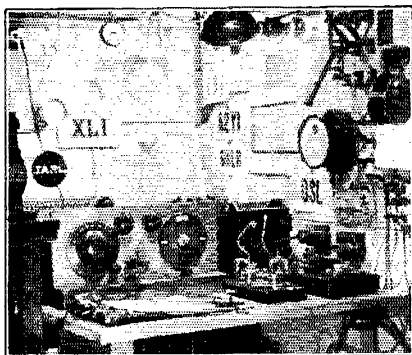

aj3WW

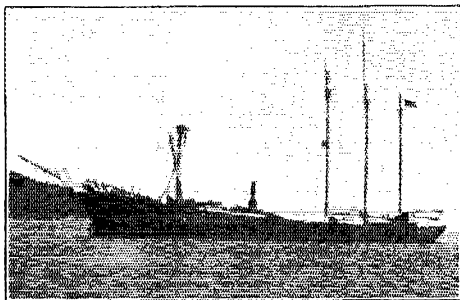

THE E. R. STERLING UPON ARRIVAL
AT ST. THOMAS

watts at 500 volts. An 8-volt battery supplied the filament. Besides this transmitter, I had the main ship's set, a 1½-k.w., 1,000-cycle, quenched spark transmitter and a 10-inch spark coil for emergency use.

"The main antenna had a flat top 140 feet long and was 120 feet above sea level. This aerial gave the best results on the

ment with parallel capacities making it possible to tune from 15 to 20,000 meters.

"The trip lasted six months and for five and a half of them we didn't have a sight of land. You will probably think that during that time I should have been in communication with land every night. That is just what I expected to do and the reason for thinking so was that I had never been to sea before on a sailing vessel.

"After leaving New Zealand, we went south to 52 degrees and encountered southerly winds. They were so cold that you seemed to be frozen stiff all over, especially the finger tips. Due to this, the exhaust pipe of the gasoline driven lighting plant interested me much more than did the radio installation. It was the only means of heating that was available.

"While off Melbourne, the main lighting generator burned out due to high frequency

(Continued on page 72)

Calls Heard



KFLF, Yacht Ripple. 6BUR Operator.

Aug. 10 to October 14. Honolulu thru the south Pacific and return. All 40-meter.

1aao 1aj 1aj 1aqp 1asf 1axx 1ayl 1bbs 1bkp 1bl 1bq
 1br 1bcz 1caa 1ed 1fa 1vc 1xv 1yb 1zh 2aan 2azp 2agw
 2aj 2ajx 2aky 2al 2ann 2awi 2ouq 2dep 2hh 2ra 2sq
 2tp 2uo 3aj 3bqz 3cc 3es 3mb 3pr 3wa 4aba 4acy 4ac
 4am 4fu 4iq 4ja 4km 4ll 4nd 4px 4qb 4rm 4rn 4si
 4tf 4zz 5aav 5aaw 5aac 5aet 5afv 5agz 5ahp 5aj 5atf
 5avs 5ba 5cc 5cl 5dl 5fh 5gt 5jd 5kc 5ms 5ot 5ql
 5sf 5ux 5zav 5zl 6aaf 6aak 6abv 6adm 6adv 6agd
 6agr 6ahe 6ahi 6ahn 6akm 6alz 6am 6amw 6aum 6avp
 6ay 6bah 6baj 6bb 6bhn 6bdw 6beh 6bhj 6bhq 6bik
 6bjh 6bjl 6bjx 6bnk 6bow 6bq 6brd 6buy 6bvk 6bwt 6bx
 6bxi 6bzd 6ccr 6eda 6efn 6efy 6egn 6ehl 6ehn 6chs
 6hiz 6en 6cya 6erc 6ese 6ess 6eto 6eua 6euc 6ewj
 6ewl 6eww 6ezf 6daa 6ddo 6dep 6dev 6dfe 6dfm
 6dfr 6dhw 6dgy 6djz 6dju 6dkj 6dkx 6dlm 6dog 6dph
 6dqc 6dqq 6ec 6fh 6ix 6jn 6ju 6ji 6oi 6rj 6ta 6ty 6ud
 6uf 6vc 6xas 6xf 6zd 7abh 7adi 7aef 7afs 7agn 7alk
 7asi 7bc 7bd 7bq 7bs 7cx 7mf 7mo 7mx 7no 7rl
 7vu 7w 7xf 8aef 8ars 8awc 8avp 8bbg 8bjx 8bok
 8bxc 8ky 8djf 8dpa 8eq 8eu 8e 8it 8jf 8jq 8ow
 8pk 8pl 8sx 8sy 8abn 8adg 8adk 8adn 8ara 8aue
 8auu 8box 8bew 8bgz 8bhi 8bhm 8bpl 8bpm 8btb 8bvw
 8bwo 8ecs 8ecv 8ejh 8en 8ocq 8ete 8eww 8eya 8eyp
 8ezl 8idd 8idq 8ides 8idf 8idm 8idma 8idmj 8idn 8dr
 8eev 8efk 8ep 8hp 8kz 8m 8nz 8sa 8ur 8v oh-6ajl
 oh-6alm oh-6avl oh-6bdl oh-6boe oh-6buc oh-exy oh-6dcu
 oh-6dey oh-6dju oh-6dki oh-6dlr oh-6dph oh-6dpu oh-6nl
 oh-6wu oz-2al oz-2ap oz-2bg oz-3ac oz-3af oz-3ai
 oz-3au oz-3vk oz-3z oz-4am oz-4jw oz-4mh oz-4xi
 oz-4y oz-5aw oz-5gr oz-4go oz-4nw oz-5dx oz-6mu
 oz-7dx oz-7pf oz-8am oz-8eo oz-vqlj op-ldr op-lhr
 na-7aea na-7aeb na-7aer na-wxr ne-4fv ne-6co ne-6vo
 ne-6xt nn-1nic nn-9a nr-2fg na-bd2 sb-2bn en-oja
 sc-2bl jvi mny zb jxw fop jpp ozc xcun jkv xna
 gbk kdn kifo kfdu kdkv kudt kzn knt wwdy wnp
 wvw vwx xbl oh-fil.

etTPAR, J. Ziembicki, Lwow, Bielowskiego 6. Poland

1bfz 1dz 1ga 1cmx 1amd 1nn 1awx 1aur 1nq 1rd
 1abz 1ctw 1adn 1ajx 1avl 1uz 1axx 1bhm 1apv 1bms
 1rx 1bwi 1xue 1ix 1ask 1aac 1nx 1avl 1ac 1xm 1aiu
 1aao 1ejc 1bgt 1cc 1ekk 1eyx 1enk 1on 1dz 1bux 1wu
 1lc 1bwm 1xv 2cm 2uk 2bu 2cu 2dh 2ctf 2ayj 2asg
 2evj 2czr 2ahm 2aah 2bum 2bhm 2mb 2akz 2ccu 2baa
 2ncr 2cjd 2is 2agq 2di 2bir 2az 2tf 2tp 2iz 2xad 2xaf
 2xg 2ich 2atq 2amo 2cyx 2nd 2wy 2bv 2nw 2cxl 2mm
 2afv 2aib 2qr 2amd 2bur 2agn 3pl 3gp 3ay 3bwt 3kr
 3iuv 3zw 3ajj 3lw 4ak 4ep 4iz 4fm 4iw 4bx 4dd 4ob
 4urx 5ad 5rh 5sv 5ka 5am 5ax 5alu 5hrv 5dr 5adk ntt
 ne-lar ne-1rp ne-2fu ud-hix ne-8rg nj-8ng no-1ka
 np-4k np-4ja np-4sa ng-5xc nw-2aqw af-geft ai-di
 ai-2kw ai-2kx au-1ds ar-8fbh as-llra fa-3rra fa-8pl
 fa-8rgs fe-2vo fe-gez fi-la fi-lc fm-8pm fm-8jo
 fm-8rgs fm-8ud fm-8ju fm-8jo fm-8osp fm-8qq
 fm-8sgm fm-8st fm-8un2 fg-pm oa-2md oa-3vp
 oa-3ww oa-3xo oa-5wh oh-laxa oz-lau sa-pli so-bal
 sa-edl sa-de2 sa-ef2 sa-bb2 sa-bd4 sa-cb8 sa-en8sb-lak
 sb-lbr sb-law sb-lik sb-lic sb-lao sb-1bw sb-lap
 sb-lud sb-laf sb-laq sb-lal sb-lai sb-laj sb-lar sb-laz
 sb-lib sb-lhe sb-lbi sb-lbd sb-lqa sb-lcm sb-lib
 sb-lah sb-2ay sb-2ag sb-2ax sb-2ad sb-2ia sb-2as
 sb-2ak sb-2aj sb-2ab sb-2aa sb-2af sb-5aa sb-faa sb-nni
 sb-nf sb-sq1 sb-sqlq sb-sq4 sc-2aj sc-2ar sc-2as
 sc-2bl sc-2ah su-lcx su-lwa su-loa su-lbu su-2ak.

xen00Q, in Gulf of Mexico and Atlantic Ocean

6acr 6bpm 6brd 6byz 6buh 6eel 6ciu 6col 6dgy
 6dhj 6dhn 6dqq 6hj 6oe 6rn 7agn 7iz 7xf ne-2al
 ne-2bo ne-lar sb-lak sb-lar sb-lcx sb-lah sb-law
 sb-las nm-a8 nm-xc51 nm-xc53 nr-2fg nn-1nic oh-6dpp

oh-fx1 oa-2hm oa-2uk oa-2rx oa-3al oa-3es oa-3wm
 oa-4nw oa-5aw oa-5cm oa-5dx oa-5sr oa-6mu oa-6gm
 oa-7hl oa-7ch oa-7cw oz-1ao oz-2bp oz-2me oz-2xa
 oz-3ar oz-4ac oz-4ae oz-4am se-1fg eg-5dh eg-5uw
 eg-6yq ep-1ae ek-4ud ek-4uah am-smzf eb-4zz eb-4au
 eb-4ac eb-4rs eb-4xx eb-4ww ef-8ef ef-8gi ef-8fz
 ef-8yor ef-8aa ef-8jf ef-8cp ef-8ku ef-8sm arcx ardi
 atc ajb xed-oik xef-8arm ee-ear6 ea-gp.

nu1HV, aboard S.S. Charles Christenson, enroute from San Pedro to Balboa, C. Z.

(20 meters)

1ejh 1byl 1dm 1sz 2ctq 2vi 3mb 3mv 3ra 3wb 3agy
 3ajn 3arx 3avb 3axa 3brf 3cug 3jj 3aal 3ara 3bdm
 3bgq 3bif 3bmx 3bsz 3btw 3cie 3scq 3cmv 3cu 3dke
 3dod 3dvw 3dws 3eag 3eaj 3enu 3eob 3jm 3md 3ph
 3vm 3amm 3bu 3euh nc-3bt sc-3ag wnp ank.

(40 meters)

1als 1bed 1enz 1fl 1lv 2afv 2ahb 2aow 2ax 2awi
 2cxl 2hh 2rd 2tr 2wc 2xad 3aks 3bms 3bn 3bqz
 3mv 3pr 3adp 3bav 3bpm 3cct 3css 3dfw 3dqq 3dgt
 3dky 3dlj 3eu 3auk 3mt 3sf 3tx 3agq 3aip 3bki
 3boo 3bpa 3cau 3cc 3dbs 3ec 3gn 3hb 3nn 3bbw
 3bgq 3hqc 3kcv 3cm 3cn 3cpq 3cmv 3dfr 3dli 3ef-
 3dmt 3eky 3enp 3qj 3hb 3ll 3lz 3nk 3nr 3pr 3xi ne-8rg
 nq-2jt nq-trm nq-5ev nq-7cx ea-gp eb-4ac ef-8dmf
 ef-8fd ef-8jf ef-8sm eg-2sz eg-6yq ek-4dba ep-3gb
 fq-pm oa-2dy oa-2mh oa-2rb oa-2rc oa-2tl oa-2uk
 oa-3es oa-5hg oa-7cw oh-6ajl oh-6buc oh-6dlr oh-6nl
 oz-2ac oz-2at oz-2ga oz-3ar oz-4ac oz-4am arcx ardi
 arfs aqe tru ocdj ngm nite nwq.

3ANR, A. Sinclair, aboard S.S. H. L. Pratt, anchored off Cienfuegos, Cuba

1axm 1chg 1ckp 1yb 2bae 2abf 2aou 2avl 2awf 2azu
 2bda 2bgh 2kl 2vm 3agf 3aso 3iv 4aca 4by 4hy 4nh
 4ob 4to 5jy 5nh 5yb 6am 6bpa 6cf 8akv 8bqr 8cau
 8cjb 8dne 8dnl 8dod 9aao 9ama 9asc 9bec 9bmv 9cgl
 9dfz 9eaj 9eld 9eon 9eag 9kd nc-3cs ne-4ar nr-2acs
 nr-2ea ef-8bf eg-5mq eg-6yq sb-2ab aign irl ocdj
 vjl wnp.

50X, Robert E. Franklin, 1806 Valentine St., Houston, Texas

(Aboard S.S. Olivgore enroute Mediterranean and European ports)

1aac 1aba 1abt 1ach 1ads 1uer 1aix 1aj 1ala 1alf
 1alj 1amf 1ans 1anz 1aqt 1aql 1asa 1avk 1avl 1axa
 1bcg 1bdx 1bez 1bhs 1bke 1bni 1bsh 1bux 1bxx 1bvy
 1caw 1cio 1cj 1cjh 1cmf 1cmx 1era 1eue 1gp 1kk
 1mv 1my 1nk 1oi 1on 1rn 1ro 1ry 1ud 1xaw 1yb 1zs
 2acu 2adl 2aer 2ahf 2ahm 2ak 2alm 2aon 2apd 2apq
 2ari 2ase 2asz 2atf 2avg 2awu 2ayq 2baa 2buo 2bvd
 2bwn 2bxu 2cfc 2cjb 2cjd 2cla 2ctd 2cuq 2cvj 2cxl
 2zk 2ie 2is 2jk 2jm 2 mb 2md 3ms 2ox 2px 2rs
 2sc 2tp 2ub 2uo 2wr 2xg 2xl 2abr 3ac 3add 3ahl 3ahp
 3ajt 3akw 3bed 3bpl 3bms 3cab 3cda 3ce 3ckl 3ee
 3fz 3bu 3ie 3jm 3ow 3tt 3uy 4br 4cv 4ea 4ci 4fv
 4he 4hz 4io 4jl 4ki 4mi 4nn 4nn 4oc 4nk 4pk 4rt
 4rn 4rr 4si 4to 4uo 4xe 5aag 5adt 5afb 5afg 5aop
 5ap 5ata 5aub 5eb 5im 5kc 5kk 5nk 5si 6bz 6dgy
 6hm 6ry 7uj 7ade 7adg 7aef 7afq 7ahd 7alg 7alu
 7aly 7anh 7asb 7auc 7axa 7bab 7bau 7bbk 7bf 7box
 7bqi 7bre 7ccm 7cdd 7ced 7clp 7cor 7erp 7csr 7swb
 7ddb 7ddn 7dgp 7dkx 7dmx 7eg 7im 7kt 7nt 7sr 7sv
 7vx 7xe 7zg 7adk 7aex 7av 7be 7bg 7bnp 7buz
 7bwi 7dle 7dnn 7dr 7dul 7elb 7es 7lz 7nr 7ox 7ou
 7xa 7xi ea-gp ea-es eb-4au eb-4ax eb-4ck eb-4co
 eb-4ft eb-4u eb-4ww eb-4yz eb-7ec eb-k6 eb-k4
 eb-n33 eb-08 ee-earl ee-ear18 ee-ear50 ee-ear 59
 ef-8aro ef-8brn ef-8ct ef-8dd ef-8dge ef-8ds ef-8ds
 ef-8eu ef-8ez ef-8fz ef-8fr ef-8gi ef-8il ef-8il ef-8ix
 ef-8jf ef-8nox ef-8sm ef-8sy ef-8tel ef-8xy ef-8yn
 ef-8yor ei-jhp ei-lak ei-2ao ei-2cc ei-2nh ei-2rg
 eg-5dh eg-6vp ei-ldm ei-lno ei-lrm ek-4abg ek-4abl

(Continued on page 54)

Correspondence

The Publishers of QST assume no responsibility for statements made herein by correspondents.



QSL Percentages

Henderson, Ky.

Editor, QST:

Much has been said concerning the acknowledging of signals by card but no one has given any statistics about it. While the following figures are not exactly exciting, they are worth glancing at.

At this station out of 685 "nu" stations worked, 411 or 60% QSLed by card. To give an idea of how the various districts stand in this matter, the percentage of returns from them are as follows: sixth, 74%; seventh, 69%; first, 64%; ninth, 63%; third, 61%; second, 60%; eighth, 58%; fourth, 56% and the fifth, 49%.

These are just plain facts. What say, now, let's try to boost these averages. The old heads should remember that although they may have enough cards, there are lots of others who are anxious to get them and so have their reports in black and white or whatever other colors may be used.

I am one of the many who QSL to everyone worked or else this wouldn't be written.

—George P. Taylor, 9BAN

Pse QSR

Hq. Btry. 2d U.S.F.A. Btn.
Gatun, Panama Canal Zone

Editor, QST:

I've certainly got a grudge to get off my chest and I guess that some of the gang have it coming to them, too. It's about this traffic business and the handling of messages.

Why is it that some of the fellows have such a long hook? Why don't they cut it off some so that they can get to those messages. I have sent many and relayed many but never has one hung on my hook longer than twenty-four working hours, but it looks as though some messages intended for me are going to be on some hooks for twenty-four years. One sender has beat his messages down here and it looks like he will be grey-haired before they catch up with him.

I have spent lots of postage money getting messages to places I couldn't get to by air and I don't see why the other fellow can't do the same. I have received one message out of thirty that were headed this way. Where the others are, I haven't the least idea, but I'll bet someone feels guilty.

I know that I did when I let one slip by at first, and it's never happened since.

Although I am now off the air indefinitely, I'd like to let the gang know just how I feel about it. I feel cheated after working hard to be of service to them. However, I want to thank those fellows who kept skeds with me and you may be sure they'll hear from me when I set up in the U. S. A.

—Henry P. Karr, ex *uzEZ5*

Pse QRX

4114 N. Kedzie Avenue
Chicago, Ill.

Editor, QST:

You may or may not have come across this new form of super-obnoxious pest who is now darkening the horizon of Hamdom. This wretch in question after having QSOD with you long enough to ascertain your QRA and get a report on his signals will ask you to please QRX for a few seconds while he, presumably, makes some minor changes or answers a phone call. Blissfully unaware of his wiles, you say, "Sure thing ob glad to QRX." He then QSYs to another part of the band or perhaps a different one and in fiendish glee begins a CQ to Europe or Australia.

The courteous innocent at the other end is still QRXing. After ten minutes or so you begin to wonder, then doubt and finally shut down thinking that something has gone bad at the other end. By running over the dial, you might find your erstwhile partner working the same trick a couple of meters away.

My only delight in the matter is in thinking of the everlasting torture that must await him after he crosses the River Styx.

—Morton Fagen, 9BOA

Bugs

Box 372, Omaha, Neb.

Editor, QST:

I have been out of the radio game for a couple of months and just got my receiver going again the other night. I was greatly surprised and almost horrified at the number of poor bug senders on the air. In most cases, it sounded like a poorly adjusted bug rather than an inability on the part of the manipulator. Perhaps a little information on the subject of adjusting these bugs for best operation will not be amiss.

QRV?

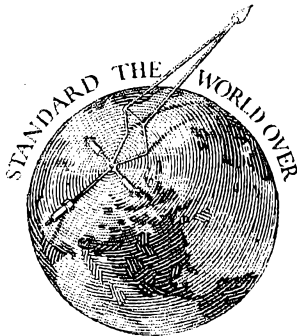

WHAT would happen if your antenna ammeter should fail during the February contest? Think of the long nights of vigil, and the many hours of constant service required of this one instrument! Stamina, accuracy, and ability to withstand accidental overloads are highly important considerations if you would avoid anxiety in the crucial test.

Why take chances? Make sure that you have the best instruments obtainable. However you decide, do not be misled by superlative statements of performance or unfounded claims. Words are available to all, and imitators usually employ them with rash extravagance. If in doubt consult a reliable laboratory.

We merely claim the privilege of reminding you that Thermo-couple type instruments are an original Weston development, and that other makes are necessarily only imitations.

WESTON ELECTRICAL INSTRUMENT CORPORATION

158 Frelinghuysen Ave., - Newark, N. J.

WESTON RADIO INSTRUMENTS

Much depends upon the Instruments you use during the February International Test

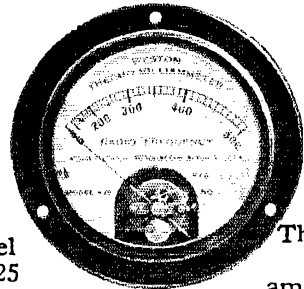

Model 425

Thermo Milliammeter

What you will find in Weston Thermo-Milliammeters

- 1—Definite assurance of your output.
- 2—Accurate readings after hours of constant service.
- 3—Extra large overloads will not burn out these meters. They will stand the following currents without damage:—
500 milliampere range—1 Ampere
250 milliampere range—750 M. A.
125 milliampere range—500 M. A.

4—Model 425 is ideal for short wave transmission, as it has a very low internal electrostatic capacity. For this reason it gives the true value of the current in the circuit, and does not disturb the constants of your transmitter.

Model 425

Radiation Ammeter

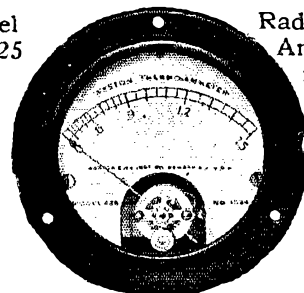

Model 425 is made in ranges from 125 M. A. to 20 amperes.

Overload capacity of ammeters, from 1 to 20 ampere ranges—50%.

RADIO PARTS for Discriminating Set Builders

Bradleyunit-A



This fixed resistor is scientifically treated to resist moisture. It is not affected by temperature, moisture or age. Provides the ideal resistance for B-eliminator hookups requiring fixed resistors of quality.

Bradleyohm-E

The remarkable accuracy of the Bradleyohm-E has caused it to become standard equipment for accurate plate voltage control on many leading B-eliminators. Use it for best results on your power-unit hookups.

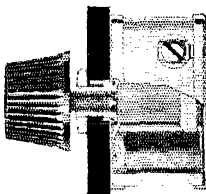

Bradleyleak

This variable grid leak provides the precise grid leak value for best results with every tube. Try it on your set and notice the greatly improved reception that results.

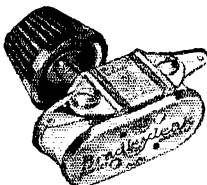

Bradleystat

The perfect filament control. Easily installed in place of rheostats now in service. Gives noiseless, stepless filament control for all tubes. Use Bradleystats on your next set and learn the difference.



Allen-Bradley Co.

Electric Controlling Apparatus
MILWAUKEE, WISCONSIN



I have used a bug on both Morse and Continental and I believe it to be a wonderful saver of time, energy and religion but let me say, never try to set a bug for good Morse work and then use it on radio. If you do, chances are that 50% of your dots will not be heard by the other operator. The reason is that for Morse work, a very light dot is required. For radio work, a very heavy dot is necessary. I got the best results from my bug by screwing up the dot contact so that the thing closes after seven or eight dots. That gives a good heavy dot that is easy to read.

And another thing, just because you have a bug and like to hear yourself send fast is no reason that the rest of the gang like it. Pull all the weights out to the far end of the bar, buy another one if necessary to slow it down and you will find that QSOs will increase and QTAs will decrease. There is nothing prettier to listen to than good bug sending on a bug set as outlined above but nothing is a greater abomination than the bug sender that thinks he should send at a breakneck speed just because he can. (Half of those fellows can't do it anyways.)

—J. H. Platz

Appreciation

3086 Eastern Blvd.
New York City, N. Y.

Editor, *QST*:

I would like to recommend the work of Charles Heiser of 55 Frances Street, Auburn, N. Y. for recognition by the American Radio Relay League.

My husband, Donald A. Cadzen, left on June 11th as ethnologist with the Putnam Expedition to Baffin Island. Through the efforts of Mr. Heiser who has been in almost constant communication with the schooner *Morrissey* of the expedition, I have been able to keep in touch with Mr. Cadzen practically all summer.

Many times, Mr. Heiser has been able to get in contact with the ship when other stations have been unable to hear her signals. He has also relayed some articles from Mr. Putnam for the *New York Times*.

I really believe his work warrants some mention in your magazine, *QST*.

—Helen H. Cadzen

Superheterodyne

Newton Center, Mass.

Editor, *QST*:

I have been re-reading with interest and appreciation, the several articles which have appeared during the past year on the use of the superheterodyne for high frequency reception. As you know, I use the superheterodyne exclusively for all my work, from the broadcasting band up to over 20 megacycles, principally because it lends itself so well to metrical work.

Using an autodyne oscillator-detector for conversion to intermediate frequency, I

POWER FOR YOUR 210 TRANSMITTER

This Thordarson 130 M.A. power supply unit will operate your 210 Transmitter at full capacity. The excellent filtering improves audibility by "sweetening" your note. This unit when in operation in the 9-J C Transmitter was reported from coast to coast at R-5 with a pure D. C. note.

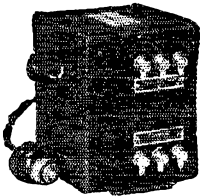

T-2098

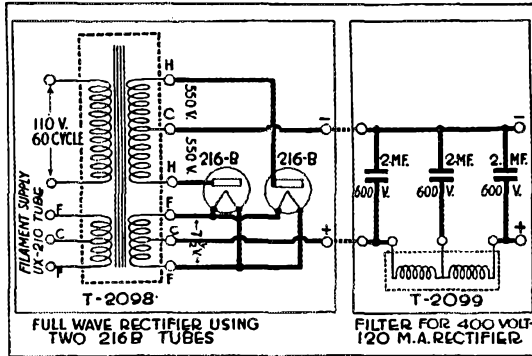

FULL WAVE RECTIFIED USING TWO 216 B TUBES

FILTER FOR 400 VOLT 120 M.A. RECTIFIER

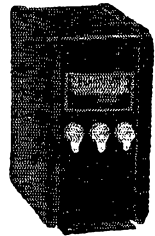

T-2099

Power Supply Transformer T-2098

Designed for use in amateur transmission and heavy duty power amplifiers using two UX-281 or two Ux-216-B rectifiers. Primary 110-115 volts 50-60 cycles. Secondary No. 1—550 volts each side of center. Secondary No. 2—7½ volts, 2½ amperes center tapped. Secondary No. 3 same as secondary No. 2. Price \$20.00.

Double Choke Unit T-2099

Consists of two individual chokes of 30 henries, 130 M.A., each. Designed as filter chokes for power supply transformer T-2098. Chokes mounted in crackle finished compound filled case. Dimensions 3¼" x 47⁄8" x 55⁄8" high. Price \$14.00.

NEW

THORDARSON

Plate and Filament Transformers

A Complete new line of Thordarson long distance transmission equipment has just been released including filament supply, plate supply and microphone transformers and filter reactors for use with all existing transmitting tubes.

WRITE FOR YOUR CATALOG TODAY

THORDARSON ELECTRIC MANUFACTURING CO.

Transformer specialists since 1895
WORLD'S OLDEST AND LARGEST EXCLUSIVE TRANSFORMER MAKERS
Chicago, U.S.A.

3574

Acme ANTENNA

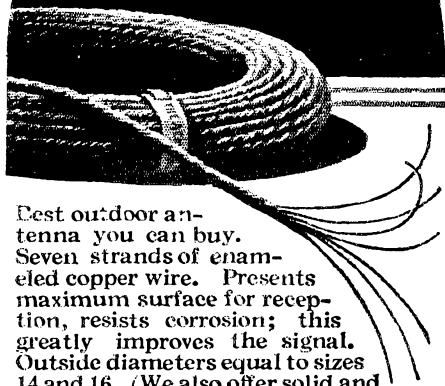

Best outdoor antenna you can buy. Seven strands of enamelled copper wire. Presents maximum surface for reception, resists corrosion; this greatly improves the signal. Outside diameters equal to sizes 14 and 16. (We also offer solid and stranded bare, and stranded tinned antenna.)

Loop Antenna Wire

Sixty strands of No. 38 bare copper wire for flexibility, five strands of No. 36 phosphor bronze to prevent stretching. Green or brown silk covering; best loop wire possible to make.

Flexible Celatsite Wire

A cable of fine, tinned copper wires with non-inflammable Celatsite insulation. Ideal for sub-panel or point-to-point wiring. Strips easily, solders readily. Nine beautiful colors sold only in 25 ft. coils, in cartons colored to match contents.



Acme

Celatsite Wire

Tinned copper bus bar hook-up wire with non-inflammable Celatsite insulation, in 9 beautiful colors. Strips easily, solders readily, won't crack at bends. Sizes 14, 16, 18, 19; 30' lengths.



Spaghetti Tubing

Oil, moisture, acid proof; highly dielectric—used by leading engineers. Nine colors, for wire sizes 12 to 18; 30' lengths. (We also make tinned bus bar, round and square, in 2 and 2½ ft. lengths.)

Battery Cable

A rayon-covered cable of 5, 6, 7, 8 or 9 vari-colored Flexible Celatsite wires for connecting batteries or eliminator to set. Plainly tabbed; easy to connect. Gives set an orderly appearance.

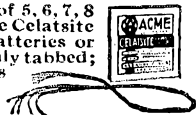

Send for folder

THE ACME WIRE CO., Dept. S
New Haven, Conn.

have repeatedly verified your observation that a more favorable signal noise ratio can be obtained than when the conversion is directly to an audio frequency. But the purpose of this letter is not to discuss this fact, but rather the means by which an audio frequency beat note is produced in the second detector.

It would appear from the columns of *QST* that there is some question whether it is better to use a separate low frequency oscillator, or allow one of the intermediate stages to oscillate. Most of my experience has been with a completely neutralized intermediate train, so that I had to use a separate oscillator, but I have recently compared the two methods, finding that the separate oscillator is decidedly better. One reason for this is that if the oscillations are produced in the intermediate train there is no easy way to clear the oscillations of harmonics, which for reception of all frequencies under three or four megacycles produce an annoying series of "birdies" from end to end of the condenser dial.

With a separate oscillator, it is a simple matter to shield, put chokes in the filament and plate leads, and then a simple filter circuit in the output, so that only the fundamental of the low frequency oscillator is applied to the second detector, and none of the harmonics get into the first detector. Not only do the "chirps" cease, but the self generated noise of the receiver is noticeably lessened.

—Greenleaf W. Pickard

Help the Beginner

3 West State Street.
Gloversville, N. Y.

Editor, *QST*:

Being an ardent reader of the "Correspondent" columns of *QST*, I would like to say a few words about communication between beginners and those who have had more experience. Much of my time has been spent working with new operators and the indifferent attitude of many hams has prompted this short missile.

It seems that within the past few months I have been in contact with several beginners and with a little patience have been able to carry on some interesting chats. During these chats, they say that they are not getting the amount of fun from their amateur operating that they had anticipated and upon questioning, one gets an answer similar to this, "Sa ob u r the first ham I hv ever QSO who cared to talk with me." The reason! Just this, the poor beginner has all he can do to receive his ten per and some of them have difficulty in copying at that speed even. The average "speed demon" considers it too much of a bore to carry on a conversation at such slow speeds and considers it to be much greater sport to carry on with someone who can rip it off at twenty-five to thirty words per. About the only thing such men are interested in is the report on their signals and, after that is had, the QSO is fin-

ACME WIRE
MAKES BETTER RADIO

Raytheon—the one rectifying tube that *maintains* constant voltage

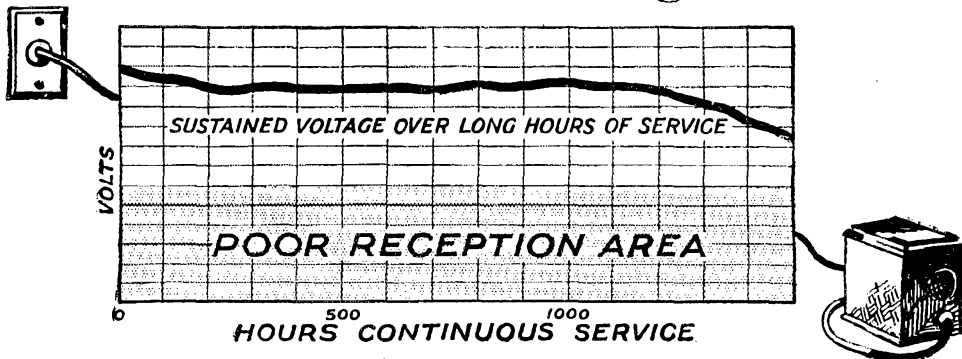

The reason? "IONIZED HELIUM"

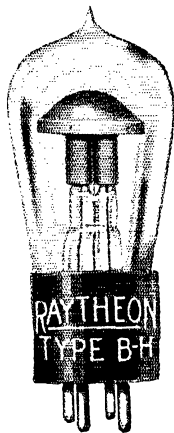

Type BH

An improved Heavy Duty Rectifier for radio power service. Maintains a constant flow of smooth, silent power, at full voltage throughout its life. Type BH is standard in those units designed to supply type 171 Amplifying tube. Guaranteed for 1000 hours over a period of one year. Rating: 125 m.a. at 300 v. Price \$4.50.

Raytheon Long Life Rectifying Tubes have demonstrated the advantages of Raytheon's principle of ionized helium gas over all other methods of current rectification. But the possibilities of this superior principle are almost beyond comprehension. In the Raytheon Research Laboratories a group of scientists are continually discovering new properties and further capabilities of ionized helium gas which will be incorporated in future developments when manufacturers have advanced their products sufficiently to accommodate them.

Today, the simplest and most satisfactory method for receiving complete light-socket operation is the series filament receiver powered by an A-B-C power-unit using but one rectifying tube—the Raytheon type BA. Tomorrow may see still further advances and Raytheon is ready for them.

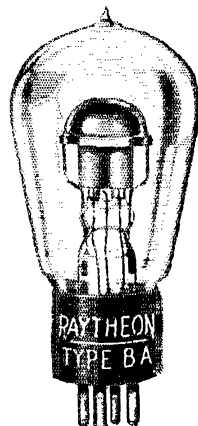

Type BA

Only One Tube for Complete Battery Elimination. Due to its unique characteristics, the Raytheon type BA tube, when incorporated in the proper circuit, provides ample noiseless and dependable power for receivers employing any number of type 201-A tubes in series. Any battery set can be rewired to operate directly from this one-tube power-unit.

Type BA—\$7.50

Raytheon Manufacturing Co.

Cambridge, Mass.

Raytheon

LONG LIFE RECTIFYING TUBE

Precision Resistance at Low Cost

You'll appreciate the Volume Control Clarostat. It's a little fellow, compact, good looking, inexpensive, handy—just the thing for the receiver itself. Hot stuff for controlling regeneration in short-wave reception. Can't be beat for regulating r.f. and detector plate voltages. It's there as a means of matching transformers, controlling volume and other applications requiring precision resistance. Practically zero to 500,000 ohms in several turns of knob. Ample current carrying capacity for receiver applications. Holds resistance adjustment. Silent in operation. One-hole mounting. Screw terminals. And all for \$1.50!

VOLUME CONTROL CLAROSTAT



OF course you must continue to use the Standard Clarostat for handling heavier currents, and the Power Clarostat for the heaviest currents, as heretofore.

THERE'S a Clarostat for every "ham" need. Make sure, however, you get a genuine Clarostat—look for distinctive green box and name CLAROSTAT stamped on nickel shell. Don't be fooled, O. M.!!

You know more about how to use Clarostats in your work than we do. But if you want our dope, just address:

American Mechanical Laboratories, Inc.

Specialists in Variable Resistors

285 N. Sixth St.

Brooklyn, N. Y.



ished as far as they are concerned. This lets the beginner out.

When I first started, I know I had both hands full to get my ten per but I will say that with but very few exceptions all the hams I ever tied in with gave me an even break. I wonder what is responsible for these changed conditions? We all had to go through the same stages and I suppose that we just forget for a moment about this. I am sure that the man who now rips it off at thirty per will agree with me that he was no "speed demon" when he made his first QSO. Many of us laugh when we think back of the thrill of the first real QSO that we had. If we would only remember that this is the same thrill that the beginner is getting, we would lay aside a little more time for an encouraging chat with him.

Is DX more thrilling than a slow, drawn-out QSO with a beginner? Certainly, but remember we are not doing this for ourselves, but for the other fellow who is following along in our footsteps. Let's make it, "One for all and all for one" and give that beginner a little more time than just enough to find out our QRK. What say, OMs?

—Charles S. Robbins, 8CRF

Another Angle

803 East 7th Street

Superior, Wisc.

Editor, QST:

Sometimes I get so sick and tired when I read of the new hams that say the old timers won't give them a hand that I want to go out and shoot the works or else blow my fifty.

Why? Because the old timers won't help them? No! Because the young squirts have the crust to ask for it.

I'll tell you why. First, when radio was young, or rather when KDKA first started tormenting the ether with strains of heavenly (?) music, several fellows came to me and asked me to help them build sets so that they could receive aforesaid music—adding that code work might interest them later. I helped them and received a bare thanks.

That was all right. Being naturally modest, I didn't care whether they said thanks or not. I rested peacefully in the thought that radio was to have several more amateurs in a short while.

Then, when stations began to be smeared all over the band, my transmitter happened to cause a little disturbance to those receiving near 200-meters. And here came the surprise.

These BCLs that I had helped when they were green as grass, were the first to jump on my neck. I shared hours with them and still they kicked. They wrote the Radio Inspector instead of coming to me. They cut down my counterpoise and threatened bodily injury.

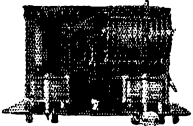

BEGINNER'S TRANSMITTER



TRANSMITTING INDUCTANCES-

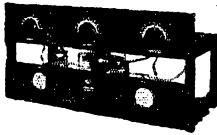

TUNED PLATE TUNED GRID



50 WATT SOCKET



WAVEMETERS

TRANSMITTING

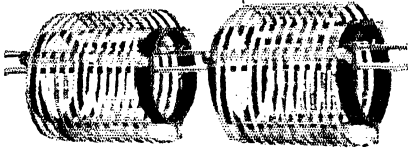

INDUCTANCES

There are more REL Transmitting Inductances in use throughout the world than the combined output of all other Inductance makers.

Equip your station with them now.

Double unit—\$11.00, complete with glass coupling rods and 6 clips.

Single unit—\$5.50 (3 clips)

RECEIVING



RECEIVING COILS

These were the first short wave coils made for the Amateur and are now a part of the receiving equipment in every well known amateur station throughout the world. Wavelength range 15 to 100 meters with .0001 mfd. condenser. Kit includes six coils with base mounting. Price \$6.00.

REL

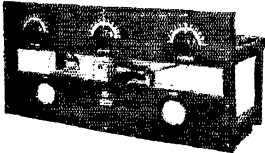

TRANSMITTING KITS

Tuned Plate Tuned Grid (pictured), Hartley, M. O. P. A. and Beginner's Transmitter are all noted for their peerless construction and fine performing qualities. We have a transmitter that will fill your need. Prices on application.

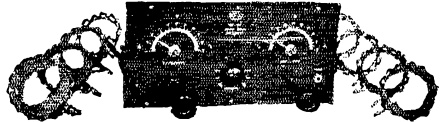

No. 130 RECEIVING KIT

This was the first Receiving Kit ever produced for the Short Wave enthusiast. Its popularity is increasing every day. The price is unusually low at \$36.00.

REL's catalogue is something you shouldn't be without. The stock of complete Dope on S. W. "or what have you" will come in mighty handy many times. Send for your copy today. 25c cash or M. O.—and we keep it up to date for you by issuing timely bulletins.

REL owns and operates experimental Station NU2XV on 15.1, 30.2, and 60.4 meters

Radio Engineering Laboratories

100 Wilbur Avenue, Long Island City, N. Y.



REL CHOKE COIL

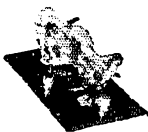

DE FOREST "H" TUBE HOLDER

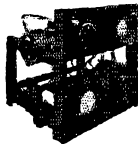

50 WATT COUPLED HARTLEY



UX-832 TUBE HOLDER



SPECIAL SHORT WAVE COIL KIT

Say You Saw It In QST—It Identifies You and Helps QST

RECTOBULBS

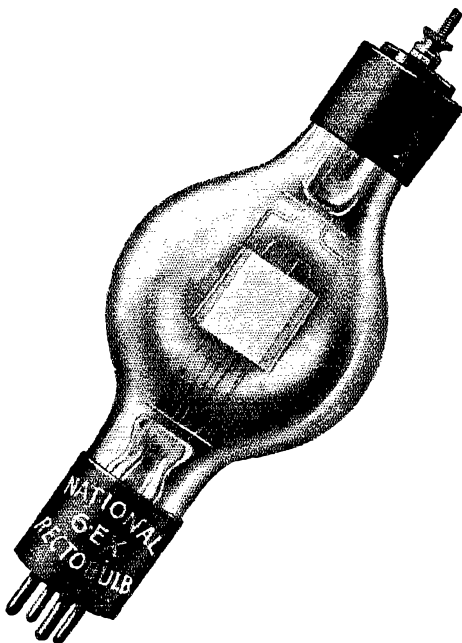

Our NEW ENLARGED FACTORY has enabled us to meet the large demand for our products:

Rectobulbs—the answer to the plate supply problem—SIMPLE—EFFICIENT—DURABLE and LOW PRICED. 10 volt Filament (Regular 50 watt) 3000 volts on plate and 250 Milliamps on plate: 200 volts drop at full load; a beautiful job. Price \$15.00 each.

National Type 203 — Guaranteed against stem puncture. 10 Volt Tungsten Filament—1500 Volts on plate—150 milliamps. Price \$20.00 each.

National Rebuilt tubes—burnt out tube must be forwarded—203 rebuilt . . . \$15.00 ea. 203A with Tungsten Filament . . . \$19.00. 204 and 204A with Tungsten Filament . . . \$50.00 each. All goods shipped Express C.O.D. and no crating charge on shipments where cash accompanies order.

We guarantee delivery in perfect condition. (All our Australian and New Zealand shipments have arrived in perfect shape).

We guarantee our products against all defects in material and workmanship and unsatisfactory operation.

Watch this space next month for announcement of the New short wave coils—plug in base—sealed in tube and evacuated—calibrated to each ham band—a Little Big Thing for the Ham.

NATIONAL RADIO TUBE CO.
(6EX) 3420 18th St. San Francisco, Cal.
(A ham institution)

Still, when anything went wrong with their sets, who did they call for but "the amateur around the corner." Two faced—

And now, when a BCL says that he is interested in learning the code and would like to get into the amateur game here is one brasspounder that looks at him twice and tells him to help himself—I did—and so can they.

If he has made an effort to collect the stuff for a transmitter and tries to make it work and can't, then, and then only, do I offer to help him. Look that over, you newcomers, and still say that the average amateur won't help you get started. You can't say that amateurs are a snobby lot for they aren't. If you will subscribe to *QST*, buy some junk to make a transmitter, I'm willing to bet my bottom dollar that the "amateur around the corner" will help you get into the game.

—Earle Hanson, ex9BOB

Financial Statement

BY order of the Board of Directors the following statement of the income and disbursements of the American Radio Relay League for the third quarter of 1927 is published for the information of the membership.

K. B. WARNER, Secretary.

STATEMENT OF REVENUE AND EXPENSES FOR THE THREE MONTHS ENDED SEPT. 30, 1927.

REVENUE			
Advertising sales, <i>QST</i>	\$16,473.94		
Newdealer sales	11,561.24		
Handbook sales	2,540.68		
Dues and subscriptions	9,169.37		
Back numbers, etc.	442.22		
Emblems	214.25		
Interest earned, bank deposits	188.65		
Cash discounts earned	314.18		
Bad debts recovered	30.92	\$40,935.45	
<hr/>			
Deduct:			
Returns and allowances	4,915.53		
Discount 2% for cash	216.20		
Exchange and collection charges41	5,132.14	
Net Revenue			35,803.31
<hr/>			
EXPENSES			
Publication expenses, <i>QST</i>	12,659.47		
Publication expenses, Handbook	44.00		
Salaries	13,671.40		
Forwarding expenses	506.46		
Telegraph, telephone and postage	1,821.64		
Office supplies and general ex- penses	2,158.96		
Rent, light and heat	922.05		
Traveling expenses	1,778.35		
Depreciation of furniture and equip- ment	238.76		
Bad debts written off	696.65		
Communications Dept. field ex- penses	80.36		
Total Expenses			34,573.10
Net Gain from Operations			\$ 1,230.21
Additional net gain due to restoration of litigation expenses in first and second quarters, now charged against Surplus ap- propriation			1,152.70
			\$ 2,382.91



A
Quality
Instrument

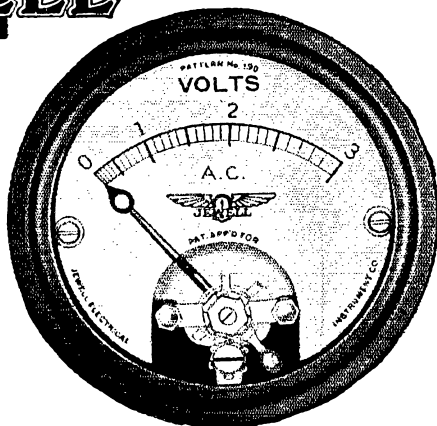

Pattern
No. 190
Panel Mounting
A. C. Voltmeter

A. C. Filament *Voltmeters*

Transmitting and receiving tubes using A. C. excited filaments require an accurate means of determining the exact voltage applied to the filaments. This can best be accomplished by the use of a suitable alternating current voltmeter.

For amateur use the Jewell 3-inch instrument Pattern No. 74 has been the favorite for many years, but the advent of alternating current tubes for receiving sets required the development of a smaller instrument and which Jewell has provided in their Pattern No. 190, illustrated.

Pattern No. 190 is a flush mounting instrument of the conventional moving vane type with special modification for its small two-inch case. It is accurate and neat, and in general appearance matches the Jewell Pattern No. 135 direct current type. It is designed for continuous service and consumes a small amount of current. It is made in ranges of 0-1.5, 0-3, 0-5, 0-15 and 0-150 volts. The 1.5 volt range is suitable for tubes using directly heated cathode, the 3-volt range is used for tubes having indirectly heated cathodes and the 150 volt range for primary control.

The Jewell 15C Radio Instrument Catalog gives a complete description of Jewell miniature A.C. instruments. Write for a copy of it.

Jewell Electrical Instrument Co.

1650 WALNUT ST., . . CHICAGO

"28 Years Making Good Instruments"

REFERENCES and BOOK REVIEWS

By R. S. Kruze, Technical Editor

New Year Bargains for ye ham station

2MA Co. is now largest concern run by hams for hams in the U. S. No delays—prompt service. Money back guarantee. All standard apparatus. Lowest prices in the U. S.

- REL 20-40 or 80 meter transmitting inductance double with coupling rods, complete **\$8.85** each
- AERO 20-40 or 80 meter transmitting coil kits Also 15-130m. S. W. Receiving coils **\$9.75** each
- THORDARSON Combined plate and fil. trans. NEW TYPE formers; 650 v. plate and 71/2" v. fil. winding, mid-tap **\$6.20**
- 80 watt fil. trans. 8 v. with mid tap **\$6.10**
- 150 " " " " 12 v. " " " " **\$7.85**
- 100 " Plate " 350 and 650 v. " " " " **\$10.90**
- 450 " " " " 1000 and 1500 v. mid tap **\$16.40**
- JEWELL 3 in. Flush mount 'x AC or DC voltmeters milliammeters—any scale readings **\$5.95**
- Antenna thermo-ammeters, any scale reading **\$9.80**
- CARDWELL New type Condensers T 199 .00035 mfd cond. T 183 B .00015 " " " " 147 B .00045 " " " " **\$8.90** each
- GRID Large General Electric 5000 ohm Ward-Leonard Cent. tap 5000 ohm **\$1.45**
- LEAKS Small Ward-Leonard Cent. tap 5000 ohm Crescent Lavite 5000 ohm special **\$1.80** **\$2.20**

FIXED CONDENSERS

- SANGAMO Large .002 mfd. 500 volt **\$.50**
- By-Pass Up to .005, 3500 volt **1.50**
- Condensers .002 mfd., 5000 volt **1.75**
- FLECHTHEIM 2mfd 1000 volt **2.75**
- Guaranteed 4mfd 1000 volt **4.75**
- Filter 1mfd 2000 volt **2.75**
- Condensers 2mfd 20-0 volt **4.35**
- 3mfd 2000 volt **6.95**

(Flechtheim filter condensers are guaranteed against break down. Blown condensers will be promptly replaced without charge.)

PYREX STANDARD SOCKETS For 202s, 210s, etc. **65c** Products at Lowest Prices Ever Sold. Money Back Guarantee.

Radio 2MA Co. 168 Washington St. N.Y.

Lefax Radio Handbook revised 1927, by Dr. J. H. Dellinger. Published by Lefax Inc. 9th and Sansom Sts., Philadelphia. Price \$3.50 or with one year's supplementary leaflets \$7.50.

Like the preceding editions of this well known reference handbook this particular one is divided into sections marked by heavy pages with index tabs with headings such as "What Radio Does," "Fundamental Principles," "Receiving and Transmitting," "Assembly of Receiving Sets." The headings already given suggest that the book attempts to cover an enormous territory and must therefore not be expected to be exhaustive in any one field. On the whole the attempt is successful and the information given is concise and useful. One unfortunate exception must be noted. The transmitting circuits are confusingly drawn and are without exception conductively coupled to the antenna in manners not permitted by law in the station of an amateur. This is doubtless one of those accidental "carry overs" from an earlier edition such as sometimes escape even the most careful reviewer.

Les Ondes Electriques Courtes by Rene Mesny, Professeur d'Hydrographie de la Marine. Published by Les Presses Universitaires De France. Received for review through the courtesy of E. M. Zandonini, Radio Section, Bureau of Standards.

It is unfortunate that this book is not printed in English as well as French for we have nothing of the sort insofar as I know. Not only is the general subject of short wave propagation well covered but in addition to this there is material regarding directive transmission with reflectors and with special antennas in which either the horizontal or vertical portion of a bent system is caused to cancel out. There is also a discussion of linear antennas in several attitudes and the operation of antennas at a harmonic. There is quite a generous amount of material on extremely short waves (below 1 meter) of which the larger part is known to the short wave experimenter but is not ordinarily available in one place. Above all, there is that very important thing, a good bibliography.

Everyman's Guide to Radio, Vol 1, Edited by Raymond Francis Yates, 187 pages, liberally illustrated. Published by Popular Radio Inc.

The title page of this book carries a list of 12 "contributors to this volume" and it is presumed that the bulk of the text is supplied by them. If this surmise is correct one must credit the editor with a remarkably well unified piece of work for it is no simple trick to combine the writing of different people. Besides this the book is illustrated much more liberally and much better than is the custom so that one does not need to overcome an unpleasant first impression. There does not seem to be any reason why "Everyman's Guide" may not become an institution by the comparatively painless process of making additions and changes from the same sources which served so well in this case. It is very probable that this has been in the mind of the editor and that for such a reason he has adopted the weird system of labeling the different figures "F-3," "I-5," "NN" and the like, thereby very definitely preventing the reviewer from discovering how many figures there actually are.

The following list of references makes no pretense at completeness but includes simply such material as is encountered through the ordinary activities of this desk.

X-ray and Radio Valves, J. Taylor, E. W. & W. E. Nov. 1927.

The Performance of Valves in Parallel

"All Experimenters! Here is Your Book at Last!" (Review, 1st Ed., Q. S. T.)

EXPERIMENTAL RADIO THIRD EDITION

By Professor R. R. Ramsey, Indiana University 117 experiments, 150 figures, printed and bound in permanent form. Just off the press.

"Then as now we recommend it very strongly to the Radio Experimenters." (Review 2nd Ed., QST.)

Not a text-book but an experimental manual. "The author contends it is not a text book. It is the best text we have ever seen." N. Y. Sun.

The book that tells you HOW as well as Why. Price \$2.75, postpaid or C. O. D.

Ramsey Publishing Co., 615 E. 3rd Street Bloomington, Indiana

SAMSON RAYTHEON THORDARSON AMERTRAN QPS



What Power Unit are You Building?

Dubilier Condenser Blocks for these well-known B and A B C power supplies are all that the care-taking experimenter could ask for in ruggedness, accuracy, safety and long life. Dubilier Type PL 574 is designed especially for the Thordarson R 171 Power Compact, and all light-socket devices employing the Raytheon BH Rectifying Tube. Maximum transformer voltage should not exceed 700. Type PL 575 block is the approved condenser for Thordarson R 210 Power Compact, AmerTran, Samson and all other power supplies using 216 B or 281 type filament rectifiers. Maximum transformer voltage not to exceed 550 V. per plate. Full instructions enclosed. Your dealer has them. Type PL 574—\$16.50. Type PL 575—\$17.50.

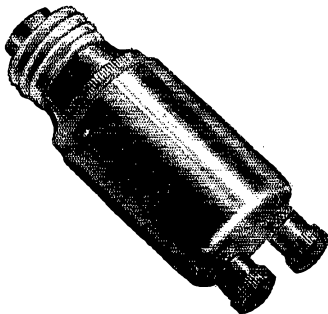

You Can't Build a Better Aerial!

So why bother with a troublesome, expensive outdoor antenna? Just connect the Dubilier Light Socket Aerial to your set and plug in. All the distance you need, all the volume you want, and clarity that an outdoor aerial can't touch. Less static, less interference and no lightning hazard. You risk nothing to prove it, for all good dealers sell the Dubilier Light Socket Aerial with a 5-day money-back guarantee. Price \$1.50.

A bulletin covering power packs and Condenser Blocks for every radio need will be sent upon request. Write for it.

Dubilier Condenser Corporation

4377 Bronx Blvd.

New York, N. Y.

Dubilier CONDENSERS

KARAS A-C-FORMER

FILAMENT SUPPLY

Type 12

LIST PRICE
\$13.50

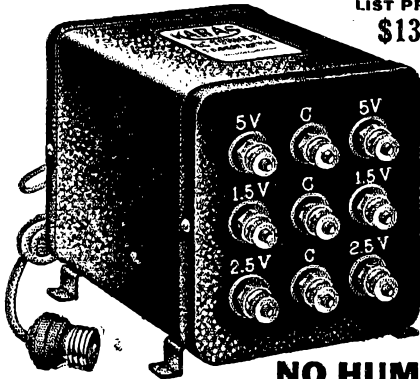

NO HUM!

At last you can step down your 110 volt A. C. house current to operate your set with standard A. C. tubes such as Cunningham, RCA and CeCo. without having to use separate device for center tap, and with ABSOLUTELY NO HUM. Let the Karas A-C-Former Filament Supply, Type 12, replace your "A" Battery and charger. Will operate 3 1/2 volt Type 225 or 326 Tubes, 2 2 1/2-volt Type 227 or 327 Tubes, and 2 5-volt Type 177 Tubes at one time. Compact, powerful, sturdy and built the Karas Way—by precision methods. Write for complete information about the new Karas A-C-Former and also data on the Knickerbocker 4 and Karas 2-Dial Equamatic.

KARAS ELECTRIC COMPANY
4030 -A North Rockwell St., Chicago



Model "N"
Vario Denser

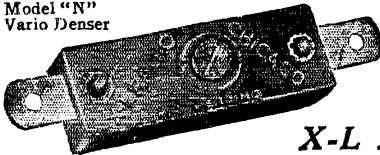

**Pep Up
Your Set
With
X-L Products**

Easier tuning—correct tube oscillation—more volume and clearness with an X-L VARIO DENSER in your circuit. Specified and endorsed by foremost Radio Authorities in all leading circuits.

MODEL "N"—Micrometer adjustment easily made, assures exact oscillation control in all tuned radio frequency circuits. Neutrodyne, Roberts 2-tube, Browning-Drake, Silver's Knockout. Capacity range 1.8 to 20 Mfd. Price \$1.00.

MODEL "G"—Obtains the proper grid capacity on Cockaday circuits, filter and intermediate frequency tuning in super-heterodyne and positive grid bias in all sets. Capacity range, Model G-1 .00002 to .0001 Mfd. Model G-5 .0001 to .0005 Mfd. Model G-10 .0003 to .001 Mfd. Price each with grid clips \$1.50.

X-L PUSH POST—NEW! Bakelite insulated. Push it down with your thumb, insert wire, remove pressure, wire is firmly held. Vibrations will not loosen, releases instantly. Price each 15c.

Also in strips of 7 on black panel marked in white. Price \$1.50.

FREE New up-to-date book of wiring diagrams showing use of X-L units in the new FORTIN-WHITE constant coupled radio frequency circuit, and in other popular hook-ups, also the Goodwin Aperiodic Detector Circuit, applicable to any set; adds a stage without added tuning controls. Write today.

X-L RADIO LABORATORIES, 2428 No. Lincoln Ave., Chicago, Ill.



**X-L PUSH
POST**

R. P. G. Denman, E. W. & W. E., Nov. 1927.

A Plea for Choke Coupling, A. L. M. Sowberry, Wireless World, Nov. 9, 1927.

Changes in Frequency Due to Shielding, H. A. Zahl, Radio News, December, 1927.

A Versatile Testing Outfit, J. F. Rider, Radio Engineering, Nov. 1927.

Theory of Receiving Aerials, F. M. Colebrook, E. W. & W. E., Nov. 1927.

The Telefunken Broadcast Transmitter in Germany (apparatus at all classes of stations) W. Meyer. Same reference as above Transmitting Antennas, M. A. Cremailh (Part 2). Very good discussion of antenna possibilities QST Francais, August 1927.

The Horizontal Hertzian Aerial For Transmission, M. G. Scroggie, Experimental Wireless, March 1927.

Daily Variations In The Heavside Layer, H. Lassen, Elektr. Nachrt, Technik, July 1927.

Approximate Theory of the Flat Projector (Franklin) Aerial used in Marconi Beam systems. J. A. Flemming, Wireless World, July 1927.

Automatic Modulation Control In German Broadcasting Stations, Austria Radio Amateur, July 1927.

The Rheinland Sender (50 kilowatt broadcast station) Austria Radio Amateur, May 1927.

A Study of Coil Resistances at 40 Meters, L. B. Root, general radio experimenter, February, 1927.

The making of Paper Condensers, Muter, Radio, July 1927.

Articulation Curves, Radio Broadcast, July 1927.

~~Strays~~

Here is a date to paste in your hat! The Third Annual Convention of the Institute of Radio Engineers will be held on January 9th, 10th and 11th in the lobby of the Engineering Societies Building, 33 West 39th Street, New York City.

The program will include the installment of the new officers for 1928, presentation of the Liebmann Memorial Prize by Dr. A. Hoyt Taylor, eight technical sessions and some trips. These trips will give all a chance to see the new high power experimental transmitter of the Bell Telephone Laboratories at Whippany, N. J., and also the opportunity of going through the new Holland Tunnel under the Hudson River. The other trips will be to WJZ at Bound Brook and to the new Roxy Theatre where demonstration of the making of talking movies will be given. On the last evening, a dinner-dance will be held.

All who have attended previous conventions of the I. R. E. will want to come to this one and those who have not heretofore had that pleasure should make sure that they don't miss it this year.

ALUMINUM

The mark of Quality in Radio

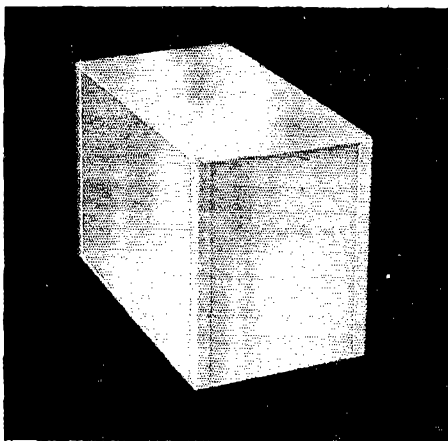

Aluminum Box Shields

*Used in the Q. S. T.
December S. W. Set*

FOR greater selectivity, finer appearance, longer life, lighter weight, use Aluminum Box Shields in the set you build—and look for Aluminum Shielding in the set you buy.

Designers agree on the superiority of Aluminum for shielding. It has become an established factor in radio design—recognized alike by advanced amateur set builders and engineers responsible for commercial production.

Aluminum Company of America's standard box shields, designed especially for

amateur sets, are made of heavy Alcoa Aluminum with satin-dip finish, size 5 in. x 9 in. x 6 in. high. They are easily adapted to smaller sizes. They require no soldering.

Three of these standard Alcoa Aluminum box shields are called for in the Q. S. T. Short Wave Set described in the December issue of this magazine.

If your dealer cannot supply you with Aluminum Box Shields send us his name and we will see that he is put in position to service you promptly. Be sure to send, also, for a copy of the new edition of "Aluminum for Radio." It is free.

ALUMINUM COMPANY OF AMERICA

2460 Oliver Building

Pittsburgh, Pa.



Say You Saw It In QST—It Identifies You and Helps QST

LEEDS

The Home of RADIO
45 VESEY STREET
NEW YORK

New York's Headquarters for Transmitting Apparatus

Full line of Acme -- Thordarson--Jewell Flech-
them -- General Radio -- Signal -- Bradley

SPECIALS

Faradon U.C. 1803 Condenser cap. .000925-10.000 volts	\$.45
Dubilier Alfa Condenser .002 cap. 6.000 working volt	1.95
Cardwell Condensers double spaced for transmitting	3.45
Genuine Bakelite Panel 10x14 $\frac{1}{4}$	1.50
Teco--50 Watt Socket	1.45
R.C.A.--U.V. 712 A-E transformer	2.45
R.C.A.--U.V. 1716 Super Het. ..	1.45
R.C.A.--U.V. 1714 R-F ..	1.85
Como 30 K.C. ..	2.45
Eria Push pull Trans. (set)	2.45
Eria 50 Henry Choke	2.45
Dubilier 4 mfd. filter cond. tested at 1500V. DC.	
working voltage 500	1.75
Dongan \$6 type B trans. for McCullough A C tubes,	
tapped for 1 $\frac{1}{2}$ -2 $\frac{1}{2}$ -3-3 $\frac{1}{2}$ volts	2.95
General Radio 247D .001 cond. plain or with vernier	1.75
Electrad Wire Fixed Resistance	
Type B. 25 watts. 2" long	.95
5,000 ohm. centre tapped	1.10
10,000 ..	
Type C. 50 watts. 4" long	1.45
5,000 ohm. centre tapped	1.75
10,000 ..	2.95
General Radio 247N variable cond. .00035	
Myers \$5 4 $\frac{1}{2}$ volt Det. or Amp tube, complete with	
mounting clips	.95
Meson Buzzer set. Key and buzzer	1.95
DeForest audio transformer, built for 400 v. \$10.	
list	3.45
Dubilier Duration II. E. transformer	2.95
Laville Resistance 1,000 to 150,000 ohms, all sizes	.69
Ward Leonard Resistances: fits standard base	
connections: sizes 300--600--900--1200 and 2000	
ohms	.95
\$15. Imported German head sets; very sensitive	3.45
\$8 De Veau adjustable arm micro-transmitter for	
panel mounting	2.45
Honeycomb Coils, unmounted, all sizes in stock at 1/2 price.	

MAIL ORDERS FILLED SAME DAY
10% Must Accompany All Orders

Re: The International Tests

(Continued from page 51)

some quarters for "signing on" a friend as extra op to keep the station on the air more hours per day than otherwise possible. Another individual is scheming to use an automatic transmitter to help him win. A third is entering two stations to better his chances of winning. The opportunities for getting a friend to help as op. for tuning the station to the highest degree of efficiency for different useful waves, for working up schedules in advance of the tests, are equal for everyone or as nearly so as we can make them at any rate. Frankly, we must admit we can't get the viewpoint of the man who surrounds himself with unfair advantages to assure success. We believe in competing fairly or not at all. Every participant is on his honor as a gentleman to abide by the spirit as well as the letter of the rules of the contest.

The award committee (representatives of several departments of Headquarters will be asked to serve on this) may also consider itself appointed to consider any irregularities and rule if they are unethical or unfair should occasion require a ruling. This committee on irregularities may set up any general policies it deems necessary in carrying out its work, basing these on the rules and printed announcements of the contest of course. It is necessary to draw the line somewhere to protect the interests of the average station owner who takes part in the contest--hence the committee on irregularities. This committee will consider any complaints brought to its attention and investigate if necessary. It will be assisted by a staff of specially qualified observers in different locations who will be selected and appointed just before the beginning of the contest. These observers will be non-participants on observing duty for the period of the tests. Three or more independent reports of off-wave operation (or other irregularities) from reliable sources may be accepted by the committee as sufficient to disqualify any participant. In other matters than off-wave operation, the committee shall have power to decide whether the penalty for irregularities shall be loss of points or disqualification depending on the evidence submitted. The active functioning of this committee and its observers will be even more important than during the last tests when the need for such a committee was shown due to the fact that there are prize awards involved in the decisions this time. Enough about the award and irregularities committee--remember all the rules and watch your step!

If a station shall be heard making schedules for another station for the purpose of handling test messages during the contest this shall be considered unsportsmanlike. This station shall be reported by whom-so-ever shall hear it and shall be penalized to the extent of losing all points that it is

DEPENDABLE! "B" BATTERY POWER!

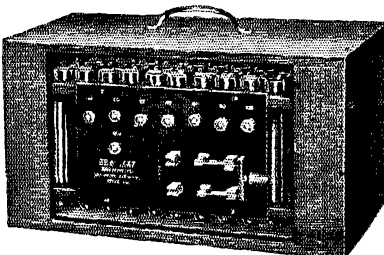

100 VOLT EDISON ELEMENT, NON-DESTRUCTIVE,
RECHARGEABLE "B" BATTERY WITH CHARGER
Shipped dry with solution\$12.00
140 VOLT WITH CHARGER\$17.00
100 VOLT POWER UNIT with TUBE\$16.00
Sample Call 20c. See how it operates.
Complete knockdown batteries all sizes at
REDUCED PRICES
180 Volt UNITS built to your specifications.
SEND NO MONEY--PAY EXPRESSMAN
Write for Free Illustrated 24 Page Booklet.
SEE JAY BATTERY COMPANY
917 BROOK AVE. NEW YORK CITY

RADIO FREQUENCY AMMETERS

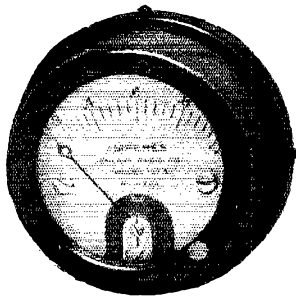

FRONT OF PANEL

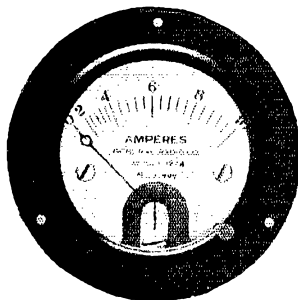

FLUSH MOUNTING

Since the hot-wire type meter is independent of frequency it may be used for any purpose in the transmitter from radiation ammeter to regulating the battery charging rate.

The 127 line of meters is supplied in front of panel and flush mounting, and portable types.

Ranges — 100 milliamperes (full scale) to 10 amperes (full scale)

Prices\$7.25 to \$10.00

GENERAL RADIO CO.

30 State Street

Cambridge, Mass.

A. R. R. L. MEMBERS ATTENTION! You are not all located within shopping distance of a dealer stocking G. R. parts. Remember that we will deliver, postpaid, anywhere in United States any of our radio parts on receipt of current catalog price. Also we welcome your correspondence. Have you Bulletin 928 in your files? If not a postcard will bring it.

PARVOLT

Formerly Sangamo

WOUND CONDENSERS

Stand
the
Surges



Capacities and prices

Series A 400 Volt Duty Mfds.		Series B 800 Volt Duty
\$.85	.1	\$1.25
.95	.25	1.50
1.00	.5	2.00
1.25	1.0	2.50
2.25	2.0	3.50
4.00	4.0	6.00



We Recommend

Sangamo Mica Condensers

THE ACME WIRE COMPANY

New Haven

Connecticut

apparent were gained through such collusion or unfair assistance or the station may be entirely disqualified at the discretion of the committee on infractions. If any U. S. or Canadian entrant shall accept and tender for credit reply test messages totalling more than 5% of the whole number of messages originated bearing the official serial number of one particular entrant, this shall be considered *prima facie* evidence of either the operation of agreements between contestants or at any rate of unfair means of point-winning thru closely following the operations of particular contestants to too great an extent. Suitable penalties shall be prescribed by the award committee. The figure given (5%) is based on a consideration of reports submitted in our last contest. We must point out that it is equally fair to all and that it is simply designed to provide a penalty for unfair collaboration between stations. The committee shall view the logs and all evidence for and against and be the sole judge as to whether collusion exists, providing suitable penalty therefor.

As a final suggestion to the U. S. and Canadian entrants—don't forget to look for the "np" and "oh" stations right in the U. S. band. They are competing with the outside world even though licensed in U. S. bands. The "eg's" on 23, 45, and 90 meters should not be neglected either.

—F. E. H.

New!

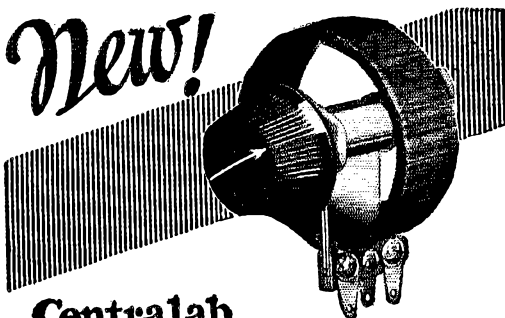

Centralab Power Rheostat

This new unit is a knock-out for warp-proof, heat-proof performance. Its construction permits continuous operation at temperatures of 482° F. and beyond. Resistance wire is wound on metal core, asbestos-insulated; core expands with wire, insuring smooth action. Narrow resistance strips give small resistance jumps per turn, further assurance of even regulation. Compact 2" diameter. Ohms—500, 250, 150, 50, 15, 6, 3, .2, .5—price \$1.25. Can also be furnished as a potentiometer. At dealer's, or C. O. D. You need this new Power Rheostat. Send postal for new circuit literature.

CENTRAL RADIO LABORATORIES
20 Keefe Avenue Milwaukee, Wis.

Centralab

Municipal Ordinances on Radio Transmission Unlawful

(Continued from page 26)

States. And Congress has covered the field by appropriate legislation. It follows that the ordinance is void as a regulation of interstate commerce.

"The motion to dismiss is overruled.

A. M. J. Cochran, Judge."

We hope everybody realizes to the fullest extent just what this means. Where other local ordinances already exist, we now have the most clean-cut kind of precedent to cite in seeking an injunction. What is more important, however, is that it is extremely unlikely if any city will attempt to pass such an ordinance, with the above in mind. The city-ordinance danger no longer exists as a menace to amateur operation.

It is most unfortunate that space will not permit the inclusion of Director Segal's brief in the case. It required a tremendous amount of work and research. It was a great case, a masterly and air-tight job, and the amateur fraternity will be forever indebted to him for it.

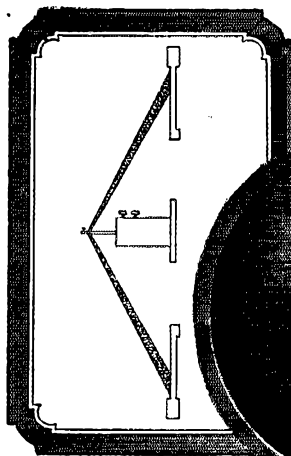
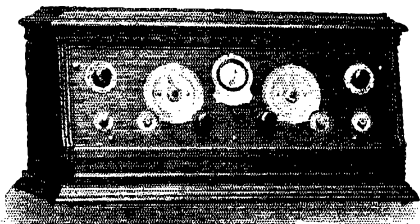

Cross section of Cone showing graduated diaphragm.

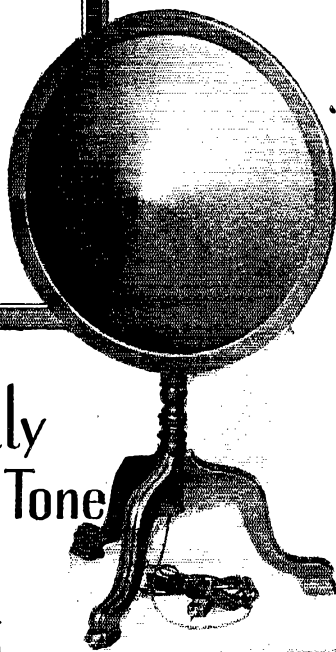

The
Cone Speaker which Faithfully
Portrays a Stromberg-Carlson's Tone

THROUGH correct proportioning of the size and shape of the cone, the new Stromberg-Carlson Speakers are able to reproduce exactly every note and vibration sent to them from the scientifically adjusted Stromberg-Carlson Receivers.

The apex [center] of the cone is thinner than the outside edge, gradually increasing in thickness from the center to the outer rim. This thinning of the "radiator" at the center makes possible accurate reproduction of the higher frequencies, while the rest of the cone gives a faithful portrayal of the low and intervening frequencies. The objectionable "paper rattle" usually found in large cones is eliminated by this graduation of the cone thickness.

Fashioned of tough paper fibres, gathered on a cone shaped form there is no grain or seam, thus insuring uniformity of tone and great durability. Another feature of these exceptional Speakers is the specially designed "baffle board" placed on the back so as to prevent rattling and resonating at the lower frequencies.

Stromberg-Carlson Cone Speakers are built expressly for use with Stromberg-Carlson Receivers. Their Superior reproducing qualities will, however, greatly improve the reception from any other high class Receiver of the same power.

Stromberg-Carlson Telephone Mfg. Co., Rochester, N.Y.

No. 10 Cone Speaker, Pedestal Type, as shown above. Price,

East of Rockies	\$40.00
Rockies and West	44.00
Eastern Canada	50.00
Western Canada	53.50

No. 11 Cone Speaker, similar to No. 10, but Wall Type. Price,

East of Rockies	\$35.00
West of Rockies	38.00
Eastern Canada	45.00
Western Canada	48.00

No. 523 Stromberg-Carlson as shown above. Price, with Audio Power Unit and 8 R.C.A. Tubes but not including Cone Speaker,

East of Rockies	\$295.00
Rockies and West	315.00
Eastern Canada	390.00
Western Canada	400.00

Stromberg-Carlson

Makers of voice transmission and voice reception apparatus for more than 30 years

Say You Saw It In QST—It Identifies You and Helps QST

FROST-RADIO

OFFERS Q.S.T. READERS TWO VALUABLE NEW BOOKLETS FREE!

Write For Them

WE OFFER readers of Q.S.T. two valuable new Frost-Radio publications free on request: "What Set Shall I Build?" the answer to a question which puzzles many set builders, and the new Frost booklet "For Better Reception," a complete and helpful manual of Frost Parts. Every set builder should have both of these booklets. They will be found check-full of useful information that is right up to the minute.

What They Contain

"What Set Shall I Build?" tells much about the newest and most popular circuits. "For Better Reception" tells you proper size rheostat for multi-tube sets, has wiring diagrams for high resistance unit, and contains valuable facts about Frost-Radio Parts.

Mail Coupon NOW!

To secure these two booklets FREE fill out and mail coupon below, printing your name and address carefully. These books will amaze you with their completeness. Write for them to-day—NOW.

HERBERT H. FROST, Inc.
Main Office and Factory, Elkhart, Indiana
Chicago New York

 HERBERT H. FROST, Inc.
 160 North La Salle Street, Chicago
 Please send me free your two booklets, as advertised in Q.S.T. for January.
 Name
 Street Address
 City State.....

energy from the radio transmitter getting into it. An electric motor was encouraged to act as a generator after some of the field turns had been removed. It was belt driven from the flywheel of the gas engine and had to travel at 3,000 revs per minute in order to deliver enough power. During bad weather that belt played all sorts of tricks and power for charging batteries was strictly limited. While I could not be on the air very often at this time, some fine contacts were made when we reached warmer and finer weather. While off New Zealand, nc4FZ was worked. This was the best DX while at sea.

After leaving New Zealand waters, all short-wave signals became weak, even WIZ. However, on 600-meters several California coast stations were copied. Gradually, amateurs in Chile, Brazil Uruguay and Argentina were worked and while off Cape Horn the sea became as calm as a mill pond.

"A few days after sailing clear of the dense ice fields off the Falkland Islands, we were struck by a fierce squally gale which in a few minutes carried off our main mast and, half an hour later, the mizzen mast also crashed to the deck. Both masts trailed over our starboard side held by the wire and rope rigging. They struck the rudder several times with great force before we were able to cut them adrift.

"After the gale moderated, the ship was once more headed toward Europe, now under jury rig, four masts remaining. A new antenna was erected and the weather conditions improved as we reached the tropics. While still a few hundred miles from the equator and only four hundred miles from the nearest coast station (Per-nambuco, Brazil), I tried for hours to push through news of the accident. Fierce static made this impossible and I tuned up the 7½ watter and with 35 watts input sent the news via nu2RS and nu8DL D without any difficulty. Many other stations also handled our traffic and I wish to thank them right here for the kind cooperation.

"On September 4th at 2 a. m., ship's time, I was QSO nu8DL D on schedule and told him I would have to QRT as it was getting too rough to work. So I closed down and turned in until 4 o'clock when I was awakened. The ship was in a roaring hurricane. When I reached the deck, there was wreckage everywhere and shreds of sail were whistling and flapping in the wind. At about 7 a. m., the large steel foremast with its six square yards of canvas crashed to the deck and the mountainous seas took charge of the ship. Ventilators, pumps and light woodwork were washed off flush with the deck. Leaving us a pitiful wreck, the hurricane subsided shortly after eight o'clock.

"The chief mate who was in a serious condition was carried to the after cabin where he died not long after.



RADIO INTERFERENCE FILTERS



Take out noises in your radio caused by motors and household appliances.

Requires NO attention.
Over 1000 now in use.

Size No. 1 for small motors, \$10
Up to 1-4 b.p.

Size No. 2 for larger equipment
Up to 5 b.p. @ 220 volts \$15

WRITE FOR PRICE LIST
TOBE DEUTSCHMANN CO.
CAMBRIDGE, MASS.

QST BINDERS

You'll NEED ONE
of these for your
1927
copies of QST

and some for your
previous volumes,
too

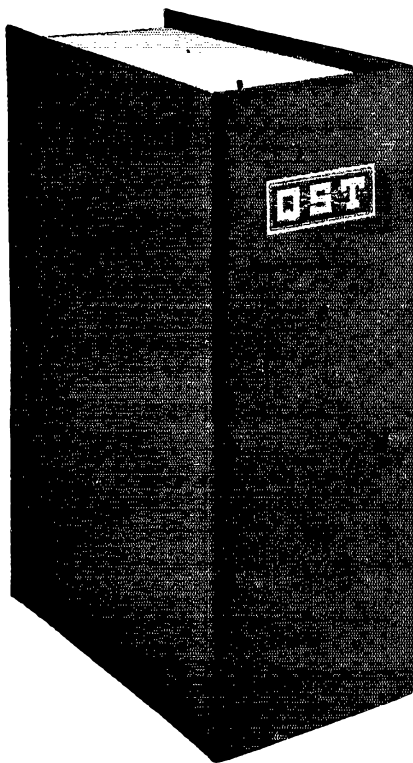

Maroon Buckram with title
stamped in pure gold
Just fits twelve issues of QST



Note the wire fasteners.
Unnecessary to mutilate
copies. Opens and lies
flat in any position.

SENT POSTPAID

1⁵⁰—ea.

Get a set to hold all your back is-
sues of QST—you know they de-
serve permanent preservation

QST
1711 PARK ST.,
HARTFORD, CONN.

Quality Amateur Apparatus

Ensall Radio Laboratory Products are Quality Built for Transmission and Reception. We supply Transmitters for Radiophone or C. W. Receivers of the Three to Eight Tube Designs with Wavelength Range from 15 to 210 Meters. Our Speech Amplifiers are supplied for Direct or Remote Control. We also make and supply, Wavemeters, Inductances, Choke Coils, etc. Distributors for Nationally known Microphones, Transformers, Plate Reactors, Motor Generators, etc. We build to order using your parts if desired. Prices on Application.

ENSALL RADIO LABORATORY

1208 Grandview Ave. Warren, Ohio
Amateur Broadcast Marine
"Pioneer Builders of Short Wave Apparatus"

"Only the center mast now being in commission, we more drifted than sailed and six weeks later we reached Sombrero Island light (about 130 miles East of Porto Rico) where the U.S.S. Grebe who had been sent by the St. Thomas naval authorities found us and towed us to St. Thomas (Virgin Islands). I have certainly been cordially treated by the two amateurs on the island np4AAN and np4ACF.

"At the time of writing this, we are still at St. Thomas awaiting the arrival of a tug which is to tow us to England. I have hopes of again QSOing the gang while on the way over and believe this part of our trip will be less exciting than that already over."

—M. B. Anderson, WIS.

JAPAN

The Japanese amateurs have at last won the right to build and operate amateur experimental stations. The government has recognized the amateur to the extent of granting licenses for such stations.

The only wavelength on which transmission can take place is 38 meters. No other waves can be used. The maximum power output is 10 watts and some licenses allow only 4 watts output. This will most probably not be considered as a handicap as many of the stations now in existence are using powers of this magnitude.

As all communication in Japan is managed by the government, these private experimental stations are strictly prohibited from handling messages and also from "chewing the rag". Stations are allowed to communicate with each other only about matters necessary to the conducting of experiments and a report on each and every such communication must be sent in to the government official who handles this matter. However, all the licensed stations will be glad to get into experimental communication with amateurs in other parts of the world.

The call letters assigned to these stations will be four lettered ones. The calls already issued are listed herewith and it will be noted that so far, three of the letters are the same for all calls, but one letter being changed to make the calls different.

- JXAX Kankichi Kusama, Hirano, Mikagecho near Kobe.
- JJBX Takesi Semba, 1-3 Sugamo, Tokyo.
- JJCX Noboru Eimura, 1102 Nakanobu Hirazuka, Tokyo.
- JJDX Shiro Akuzawa, 25 Tatemachi, Maebashi.
- JJEX Hauro Horikita, 957 Shimohebi-kubo, Ebara, Tokyo.
- JJZFX Momoki Sumi, 1401 Shimo-shibuya, Tokyo.
- JJGX Toshio Seki, 33 Sakusabe, Tsugamura, Chibaken.
- JJHX Hikotaro Takeuchi, 419 Ikebukuro, Tokyo.

There are four other licensed stations in Japan concerning which we have some in-

Ad. Auriema, Inc.
Manufacturers' Export Managers
145 Grand Street, New York, N.Y.
Scientifically equipped for economically export dependable receiving and transmitting radio apparatus.

In September we published this advertisement:

\$4 Worth of Book for \$1

SOMEbody got to figuring not long ago and made some interesting discoveries about THE RADIO AMATEUR'S HANDBOOK. They show what we mean when we say the Handbook is the biggest dollar's worth of radio literature ever offered.

This Handbook is not printed in the fashion of an ordinary book. Books are printed in relatively large type, lines clear across the page, space between lines. We found it more convenient to print the Handbook after the fashion of QST—the same size page, the same size type, and the same two columns to the page. The result is that the Handbook has that same often-unrealized quality of QST—it has an astonishing number of words between its covers. It runs three times as many words to the page as an ordinary book. If printed after the ordinary fashion of books, the Handbook would have over 500 pages!

Let's get a complete comparison. Everybody knows Ballantine's "Radio Telephony for Amateurs", universally admitted to be an extremely valuable book for every amateur. The A.R.R.L. Handbook, "The Radio Amateur's Handbook", has nearly twice as many words as Ballantine! Is Ballantine worth its \$2? You know it is. Is Ballantine profusely illustrated? The Handbook has thirty more illustrations in it than Ballantine.

If the Handbook had been produced like an ordinary book it couldn't have been sold for less than \$4. Now you know what we mean when we say the Handbook will represent the best dollar you ever spent.

"THE RADIO AMATEUR'S HANDBOOK"

A Manual of Amateur Short-Wave Radiotelegraphic Communication

By F. E. Handy, A.R.R.L. Communications Manager

Price \$1 Postpaid Anywhere

Published by

American Radio Relay League, : Hartford. Conn.

**—and now the new, revised, 3rd edition,
32 pages larger and up-to-the-minute,
is available!**

SANGAMO

AUDIO TRANSFORMERS

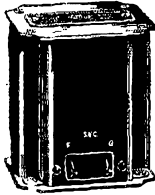

For Organ or Piccolo

From the lowest resounding note of the thundering organ to the highest pitched note of the piccolo, the Sangamo Audio Transformer amplifies every tone and every modulation with uniformity.

Brings the silvery voices of great tenors and the thrilling vibrations of the lowest bass into your home in all their original beauty.

Best results are obtained by using two Sangamo Audio Transformers (one in each stage) but one will improve any audio amplifier. A power tube should be used in the last stage.

Completely shielded. Tested at equivalent of 1,000 volts d. c. between windings and between each winding and case.

3 to 1 ratio Price \$10

*Sangamo Mica Condensers
are accurate and stay accurate.*

SANGAMO ELECTRIC CO., Springfield, Ill.

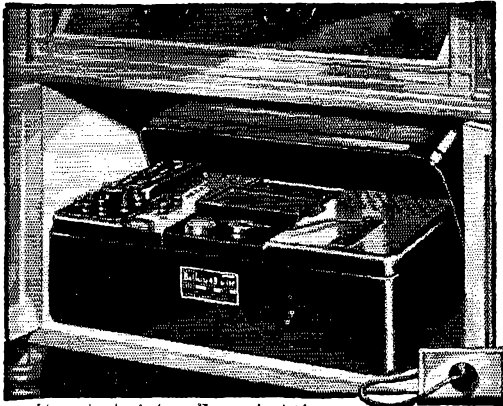

Licensed under Andrews-Hammond patent

The truest and clearest AC Electric Radio is a standard set equipped with Balkite Electric "AB" \$64.50 and \$74.50. Ask your dealer.

Balkite

Radio Power Units

formation. JKZB is a purely experimental station controlled by Y. Imaoka who is on the research staff of the Tokyo Electric Company. It is located at Kawasaki.

JLZB is the station of T. Kusumoto, 3256 Kakomi, Nakano, Tokyo. We believed this station to be doing amateur work but find out that it is operated by a government agent for the purpose of obtaining information concerning unlawful operation of stations. We believe the same thing to be true of JMPB which is run by T. Kokumai, 1242 Nakameguro, Meguro, Ebara, Tokyo. The same may be true of JLYB, I. Arisaka, 84 Kami-Umahikizawa, Komazawa, Ebara, Tokyo although we have no definite information concerning the status of this station.

All the owners of the licensed amateur stations are members of the Japanese Amateur Radio League and all letters for them or other Japanese amateurs may be addressed to the League, 1-3 Sugamo, Tokyo, Japan.

We are showing a view of aj3WW but unfortunately were unable to get any information as to just what all his equipment is. The station is located near Kobe and has done some excellent work.

AUSTRIA

"The Austrian transmitters are still unlicensed but notwithstanding this fact, the number of transmitting amateurs is increasing every day. Many of these are now in every night contact with all continents, the conditions for making contacts being very good just now, especially with the United States, Australia and Brazil.

"The official QSL service is now handling a large number of reports and the ten thousandth card has been received recently. All cards should be sent under cover to Radiowelt, Wien III, Rudengasse 11, Vienna, Austria.

"Many of our stations working on 45, 32 and 22 meters would like to obtain schedules with nu stations. Any nu stations interested in these schedules should write to the above address concerning them. Receiving conditions are improving every day and many nu stations are to be heard with signal strengths varying from R5 to R9.

"2XAF is still our favorite short-wave broadcast station and may be received on three valves with loudspeaker strength 'most every night. Very little fading is noticed."

—Th. Mossig, eaAC.

BELGIUM

"Although the 40-meter bands get crowded each autumn, it seems to be even more crowded this year than any before. This, in spite of the fact that many of our best stations are working in the 20- and 32-meter bands, is due to a large extent to the many phone stations that have come down to this wave. It seems to be very much more difficult to keep within the amateur laws, two or three phone stations than a hundred key punchers.



EVERY TRANSMITTING AMATEUR USES THESE FORMS



*—a reminder that
your supply may be low—*

A. R. R. L. Log Sheets

Designed by hams for hams. 8½ x 11 bond paper, punched for standard three-ring loose-leaf binder. 125 sheets postpaid for \$1.00 or 500 for \$3.50.

Members' Correspondence Stationery

Write your radio letters on League letter-heads—it identifies you with the biggest radio organization in the world. Lithographed on 8½ x 11 heavy bond paper. 100 sheets postpaid for 75c or 250 sheets for \$1.70. Sold to members only.

Official A. R. R. L. Message Blanks

Most convenient form. Designed by the Communications Department of the A.R.R.L. Well printed on good bond paper. Size 8½ x 7¼. Put up in pads of 100 sheets. One pad postpaid for 35c or three pads for \$1.00.

Message Delivery Cards

Neatest, simplest way to deliver a message to a near-by town. On U. S. stamped postals 2c each. On plain cards (for Canada, etc.) 1c each postpaid.

American Radio Relay League

1711 Park Street

Hartford, Conn.

HERE, AT LAST—is a filter condenser that's ALL CONDENSER. No fancy frills or unnecessary trimmings, just your full money's worth of quality all the way through.

If there is one spot in your transmitter where you cannot afford to risk uncertain quality, it is here. The tiniest defect in a \$5.00 condenser is \$5.00 gone up in smoke and possible damage to more expensive apparatus.

Don't be misled by high ratings and low prices of some condensers. Lincoln quality simply cannot be built at Ford prices. We have absolutely proved our product to be superior in actual tests. They are worthy of your confidence.

	1	2	4
	mfd. mfd. mfd.		
600 Volt D.C. Working Voltage	\$2.25	\$3.00	\$ 5.75
1000 Volt D.C. Working Voltage	3.00	5.50	10.50
2000 Volt D.C. Working Voltage	write for prices		

A New HAMALOG is yours for the asking.

E. F. JOHNSON COMPANY, Waseca, Minnesota.

Manufacturers of SILVER PLATED Transmitting Inductances, No. 29 Stand-off Insulators, High Voltage Variable Condensers, and other products.

"Half a dozen are busy working on 5-meter sets and aeri-als. Some interesting results have already been obtained and our first two-way contact took place in 1923 between Vilverde and Brussels, a distance of 5 miles. The transmitter used no regular antenna, the coils and wiring in the set doing all the radiating. Later on in the same year, Mr. Mussche, eb4BJ (old ebC2) who is our Technical Manager and who did this first work, made a good contact on a wave of 8.5 meters between Antwerp and Brussels, a distance of 40 miles. A few days ago, the 5-meter signals of eb4BD were heard in Brussels which is 100 miles from him."

—Paul de Neck, President, Réseau Belge.

The accompanying photo shows a view of eb4FT (ex ebO8), the station of G. Neelemans who is the General Traffic Manager of the Réseau Belge. The station is located at 15 rue du Luxembourg, Brussels.

The transmitter employs two German RS5 or two French 150 watt Fotos valves in a Mesny push-pull circuit having the

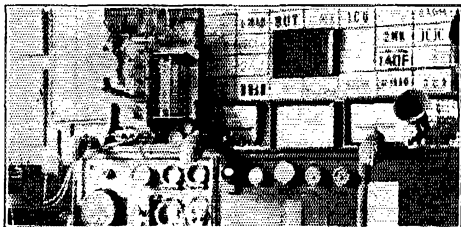

eb4FT

grid circuit tuned. The plate input is between 100 and 150 watts and the potential is 1500 volts which is obtained from an Esco motor-generator set. A fifty-henry choke and two mikes of capacity comprise the filter. A single wire horizontal aerial and counterpoise are used. All continents have been worked. The receiver is of the plug-in coil variety using a capacity control of regeneration. One stage of audio amplification is employed.

HUNGARY

"The so called 'Act of Short Waves' permits amateur transmission under regulations that are quite similar to those in force in England. Probably the best of the legally operated stations is ewH4 who has made many contacts with nu stations.

"We find that a large number of American stations send at a rate that is beyond our ability to copy and we must, therefore, forego the pleasure of working them. It must be remembered that we are just starting in with the handling of the Morse code and have still to obtain our experience. So far, we have had to be content with doing most of our work with other European amateurs.

"By no means all of our transmitters are licensed. There is a large number that are working under cover and every day we receive from sixty to eighty QSL cards for

AUTOMATIC CODE SENDER

The TELEPLEX



Makes It Easy To Learn Code at Home

The only instrument of its kind that REPRODUCES actual sending of EXPERT Operators.

Cuts Learning Time In Half

The Teleplex provides unlimited practice anytime—anywhere. Sends mes-

sages, radiograms, etc.—5 to 80 words per minute. Simple, easy and fascinating. Records consist of perforated tapes.

FREE Course (Continental or Morse)

One tape sends FIVE times as many words as any other instrument, and SIX are furnished. Tapes cannot be memorized. Last indefinitely. Used by leading Universities, Technical and Telegraph Schools and U. S. Navy. In handsome, leatherette-covered cabinet with carrying handle. With or without key and sounder, or buzzer. Fully guaranteed. Write for literature.

Canadian Representative Wanted

TELEPLEX CO., 76 Cortlandt St., NEW YORK

Faithful Service

The function of a power resistance is to control voltage and current—accurately—permanently—silently.

AEROVOX PYROHIMS used with GOOD equipment make a BETTER power unit.

AEROVOX PYROHIMS are built to last—are used by more than 20 leading power unit manufacturers.—This is conclusive evidence of their reliability—accuracy—worthiness.

Made in all values of resistance for continuous duty at 20, 40, 100 and 200 watts.

AEROVOX
"Built Better"
 70 Washington St., Brooklyn, N. Y.



GROSS COILS

GROSS SHORT WAVE LOW LOSS "PLUG-IN" COILS

The coils you will eventually use. Wound with number 16 double silk covered wire with turns spaced the diameter of a turn. It is a recognized fact that the space wound solenoid is the most efficient form of inductance. The distributed capacity is at a minimum and dielectric losses are too low to be measurable!

An extremely thin film of celluloid which only touches the turns at the very bottom, is the binder which serves to make this coil as rugged as if it were wound on a solid form. No impregnating dope of any kind is applied to the winding. The winding is extremely rigid and may be grasped firmly in the hand.

Each of these coils will cover a

sufficient range to overlap with the next smaller and larger coil. There is one for each amateur waveband and it can be plugged in and out as easily as a pair of phones.

The base which contains the jacks, also holds the antenna coil on a small swinging arm, which permits all degrees of coupling from zero to 100.

These coils will unquestionably improve the appearance and operation of any short wave receiver.

Price of base with coil for one band, \$4.50
 Price of coils only:
 20 meter band \$2.75
 40 meter band 2.75
 80 meter band 2.75
 200 meter band 2.75
 600-200 meters 3.25

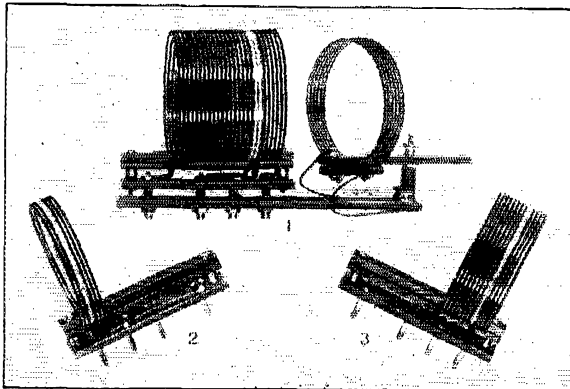

GROSS RECEIVER KITS

- Composed of high grade material throughout.
- 2 Tube Kit \$15.75
 - 2 Tube Assembled Receiver 18.00
 - 3 Tube Kit 18.75
 - 3 Tube Assembled Receiver 21.00

Above Receivers or Kits supplied with one plug in coil for 20, 40 or 80 meters, as you select. Extra coils \$2.75 each.

- Gross Transmitter Kits, Tuned Grid, Tuned Plate.
 7½ w \$47.50
 75 w \$75.00

Transmitting Inductances, Tuned Grid, Tuned Plate \$8.75 wound with copper Tubing 20, 40 or 80 meter bands.

Send stamp for circulars describing full line of S. W. transmitting and receiving apparatus.

Dealers and Representatives Wanted. Write for discounts.
J. GROSS COMPANY, 30 Park Place
 New York City



**Now That Everybody
Demands Electrically-Operated Radios
Dongan Is in Production
on All Types**

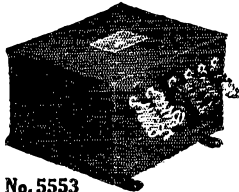

No. 5553

\$22 List

A B C Power Unit for
UX 226, UY 227, UX 171
and UX 280 Tubes.

Order from your dealer
or send check or money
order to factory direct.

Dongan Electric Manufacturing Co.
2999-3001 Franklin St., Detroit, Mich.

TRANSFORMERS of MERIT for FIFTEEN YEARS

**Here Is the
Newest**

No. 6515 Transformer
for use with 4 UX
226 1 UY 227 A C
Tubes and 1 UX 171
Tube. Together with
a B Eliminator, this
new transformer will
convert old type set
into an efficiently
operating A C set.

\$4.75 List

This is one of 14
types ranging in price
from \$2.50 to \$8.00
for use with the new
types of A C Tubes.

them. These are, of course, all sent under cover or else these stations would be getting into difficulties with the authorities. There are also many who will not take the risk of being caught while operating an unlicensed transmitter and who have devoted all their energy to the matter of reception. "I understand that there are now about fifty who have petitioned the Government for licenses and it is thought that all will receive them."

—F. Molnar.

(It is not definitely known why these "under cover" stations do not obtain licenses but it is probably due to the lack of necessary funds.—Assist. Tech. Ed.)

SOUTH AFRICA

We are showing a view of foA4L, the station of Robert Oxenham who used to supply us with our South African news each month.

On the right, mounted to the wall, is the transmitter which employs a Mullard 0/150 tube. Plate supply is obtained from

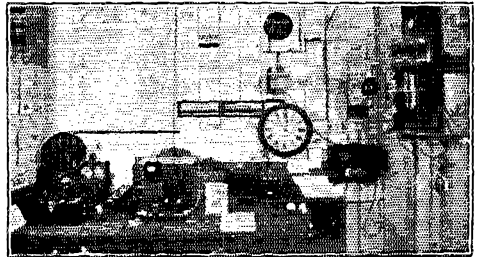

foA4L

a motor-generator which applies 1400 volts to the tube. The input is usually 100 watts although the tube is rated at 150 watts. The filament is supplied from a storage battery which may help account for the many crystal control reports received.

In the center is the short-wave receiver of the "Reinartz" type covering all the amateur waves down to ten meters. The detector tube is a B. T. H. (for the manufacturer's name, British Thompson-Houston Co., Ltd.) power tube which seems to work best with two volts on the filament and nine volts on the plate. A wavemeter and a broadcast receiver comprise the other equipment on the table.

A4L is a member of the WAC club and has made an enviable reputation not only on the air but as one of QST's most consistent correspondents during that time when he was detailed by the S.A.R.R.L. to keep us informed as to the doings of our South African friends.

As the result of a vote of the I.A.R.U. members in Australia, the Wireless Institute of Australia has been designated as the National Section of the Union in Australia.

Much credit for the successful negotiations resulting in this step is due to the



FLECHTHEIM

**Superior Condensers
For Amateur Stations**

**BY-PASS
FILTER
BUFFER
HIGH TENSION
TRANSMITTING**

**All Standard Sizes
Accurate capacity rating
Dependable for continuous duty**

Write for Catalogue

**A. M. FLECHTHEIM & CO., Inc. Dept. QT
136 Liberty St. New York, N. Y.**

BECOME A RADIO OPERATOR

See the World. Earn a Good Income
Duties Light and Fascinating.

LEARN IN THE SECOND PORT U.S.A.

Radio Inspector located here. New Orleans supplies operators for the various Gulf ports. Most logical location in the U. S. A. to come to for training

Practically 100% of radio operators graduating on the Gulf during the past five years trained by MR. CLEMMONS, Supervisor of Instruction. All graduates secure positions.

Member of the A.R.E.L.—Call "5 G R"

Day and Night Classes—Enroll anytime—Write for circular.

GULF RADIO SCHOOL

844 Howard Ave. New Orleans, La.

GET TRUE MUSICAL RECEPTION

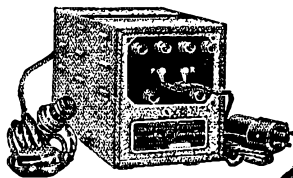

Combination

TIMMONS Combination Power Amplifier and "B" Supply

List \$70.00
(Without Tubes)

SPECIAL \$23.50
ea.

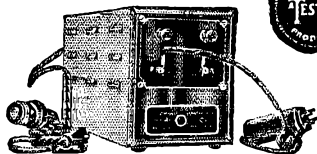

Power Amplifier



TIMMONS Power Amplifier

List \$45.00
(Without Tubes)

SPECIAL \$15.50
ea.

Both of these high quality compact units use a U.X. 216B or 281 tube for rectifying and a U.X. 210 super power audio tube as an amplifier which gives distortionless and true natural reception with wonderful tone quality and volume.

Both instruments are identical in their performance as super power amplifiers. The Combination however is also a complete "B" Eliminator furnishing all the

"B" current required by the regular tubes of the set. No adjustments required and no output transformer or similar auxiliary equipment needed with either unit. For use with alternating current 105-120 volts, 50-60 cycles.

Every unit is brand new, packed in original factory sealed carton and fully guaranteed. They have been approved by Popular Radio and Popular Science Laboratories.

AMERICAN SALES CO., 21 Warren St., New York City

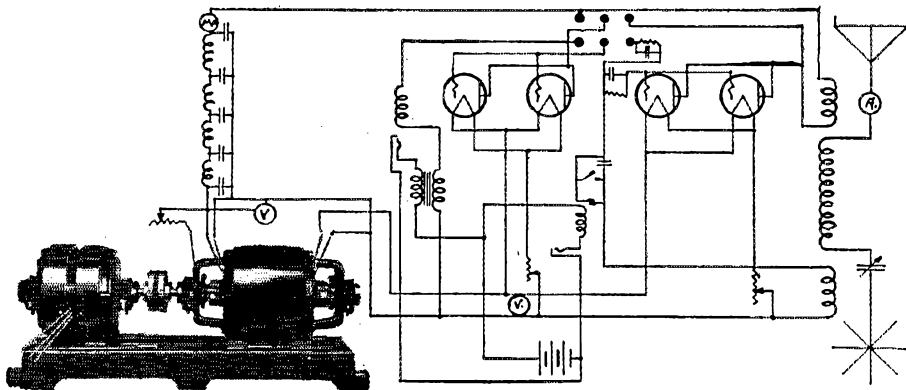

Item 37, 2 unit four bearing set, delivering 1000 volts, 600 watts for plate and 12 volts, 300 watts for filament. The "ESCO" Set is shown here furnishing Power Supply for 4-50 watters in a phone or telegraph set. This is the Item used by CB8 in pioneer achievement of the first two way amateur wireless communication between North and South America.

ELECTRIC SPECIALTY COMPANY

Mark "ESCO" Trade

522 South Street

Stamford, Conn., U. S. A.

Manufacturers of Motors, Generators, Motor-Generators
Dynamotors and Rotary Converters, for Radio and Other Purposes

A Resistor Is Known by the Company It Keeps

Ask any one of the companies listed below
what they think of Harfield Resistors:

Stromberg-Carlson Tele- phone Mfg. Co.	Western Union Teleg'h Co.
Crosley Radio Corporation	Sonora Phonograph Co., Inc.
American Transformer Co.	Conner-Crouse Corp.
Fansteel Products Co., Inc.	Magnavox Corporation
Martin Copeland Co., Inc.	Jordan-Carisch Company
Pacnet Electric Co.	Electrical Research Laboratories
Splitdorf Electric Co.	Samson Electric Co.

They are but a few of the more prominent
corporations who have turned to Harfield Res-
istors during the past year.

*Tell us about the resistor you want
and let us make up a sample for you
with prices. Write to*

HARDWICK, FIELD, INC.

FACTORY
215 Emmett St.
Newark, N. J.



SALES DEPT.
100 Fifth Ave.
New York

DODGE RADIO SHORTKUT

With Appendix and Hints for Better Key Work. Fixes
Signals in mind to stick—Kills Hesitation. Cultivates Speed
and Good Fist—Produces Results. Slow Hams raise speed
to 25 per in few evenings. Previous Failures qualify and
pass exam quickly. Beginners master code and pass in
ten days.

DODGE HIGH SPEED METHOD

(Intensive Speed Practice)
Quickly puts 25 per Hams in 35-40 per class. Five
Hams report made this gain in few evenings. One of
them by 75 minutes total practice only.

DODGE MORSE SHORTKUT

Easily mastered by Radio Ops—Kills tendency to mixup
or confusion. Either code used as desired.

REPORTS FROM USERS

Tell the complete story—Mailed on request. Radio
\$2.50. High Speed \$2.50. Morse \$2.50. Money order.
None C. O. D. Foreign add 50 cents.

C. K. DODGE. MAMARONECK, NEW YORK.

BIG RADIO CATALOG

From the "Big, Friendly
Radio House"

NEW 1928 Book offers finest,
newest well-known sets; parts,
eliminators, accessories at lowest
prices.

DEALERS — WRITE FOR THIS CATALOG!

Western Radio Mfg. Co.

124 West Lake St., Dept. 61 Chicago, Ill.

Tasmanian Division of the Wireless Insti-
tute of Australia under the able leadership
of P. Oakley Fysh, oa7PF.

Our congratulations and best wishes for
a long and healthy existence go to this,
our latest, Section.

Here is a summary of what to do about
the International Contest *if you live outside*
the United States and Canada in order to
get in on the fun and to be in line for win-
ning a prize as the best contact station in
your locality for "nc"s and "nu"s.

1. This contest will last fourteen days
(Feb. 6, 1928 0000 GCT to Feb. 20, 1928
0000 GCT). For complete details see pages
31, 32, and 33 of December *QST*—also page
51 of this issue.

2. During the tests work just as many
"nu" and "nc" stations as possible. Each
station worked will give you a short test
message with a special long serial number
which identifies the participant sending the
message. When properly acknowledged
at the time and turned in to International
Contest Headquarters as provided in the
Rules of the Contest this counts *one* in your
score.

3. To each message you get write a re-
ply whose text and signature together con-
tains ten or more words. Give each mes-
sage the serial number of the message to
which it is a reply. At the first opportuni-
ty give the reply message to a different U.
S. or Canadian station than the one from
which you got that serial number. When
you have complied with all the Rules of
the Contest this counts *three* in your score.

4. Work as many stations as you can
to run up a score. You can QSO many sta-
tions during the contest—and probably add
four points to your score for each sta-
tion worked after the first one. Turn in
confirmations promptly at the close of the
contest (Rule 7).

The U. S. wavebands that may be used
are: 18.7-21.4; 37.5-42.8; 75.0-85.7; 150-
200. Canadian amateurs use the same
waves and may also be found on 52.5
meters for work with British Dominions.
The U. S. gang now uses 20-meters regu-
larly and foreign amateurs who can use
23 meters will find it to their profit to do
so in these tests to make 100% use of
the 24-hours in each day. 80-meters is
again becoming more popular for interna-
tional work in some quarters and oppor-
tunities here should not be overlooked.

You should use any wave permitted by
your government's regulations, choosing
the ones that are going to prove most effec-
tive for your purpose. Take care that the
stations you work are *inside* one of the
bands mentioned above. Better mark the
limits of the band on your receiver and
keep the wavemeter around. North Ameri-
can stations working *outside* their assigned
wavebands will disqualify both themselves
and stations they handle test messages with.

Better get your station ready for the
tests right NOW—in readiness to go after
your share of the prizes. The prizes are

The New AmerTran Push-Pull Power Amplifier

IS A new completely assembled two-stage unit containing a first stage AmerTran DeLuxe followed by AmerTran Input and Output transformers for power tubes. When operated from a power source supplying sufficient voltage, (such as the AmerTran A B C Hi-Power Box) the input to the speaker is almost perfect, and fidelity of reproduction is limited only by the ability of the speaker. The energy output to the speaker is increased, especially at the lower musical frequencies. This means greater clarity of tone at low or high volume. The amplifier is easily connected to the detector of any good receiver, replacing its audio amplifier.

The AmerTran Push-Pull amplifier is built in several types, depending on the type of power tubes preferred. Type 2 A P-10 is designed for 210 tubes and Type 2 A P-71 for 171 Tubes. The difference is only in the Push-Pull Output transformers. This complete unit is licensed under patents owned or controlled by the Radio Corporation of America.

See this new unit and a demonstration of it at stores displaying the sign "Authorized AmerTran Dealer". Price \$60 without tubes, East of the Rockies.

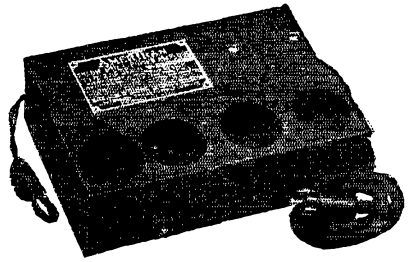

Fidelity of Reproduction

A New Standard of Quality in
Audio Amplification.

Connects to the Detector of
Any Good Receiver.

American Transformer Co.

178 Emmet St.

Newark, N. J.

"Transformer Builders for Over 26 Years"

\$21.⁰⁰

cash with order,
f. o. b. Peoria,
Illinois. Com-
plete with B. H.
Raytheon 125
m.tube. Money
back guarantee
with every unit.
(Formerly \$35.)



Guaranteed
output—185
volts at 55
m i l s o n
110V., 60
cycle. Will
operate any
set with 1 to
12 tubes.

Warren Electric Company, Dept. Q., Peoria, Illinois

Hoyt **B** ELIMINATOR VOLTMETER

Made for hard service but always accurate and sensitive.

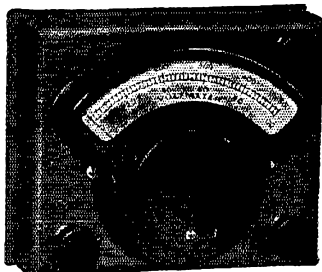

Resistance, 1000 ohms per volt,—for Radio service-men, dealers and manufacturers. Precision d'Arsonval movement, 3½ inch scale, *hand-cali brated*. The damping is very fine. Polished base. Ranges, 0-100
0-500 volts

Price—\$28.00

Write for booklet "Hoyt Meters for Radio."

BURTON-ROGERS CO.

Sole Selling Agents
BOSTON, MASS.

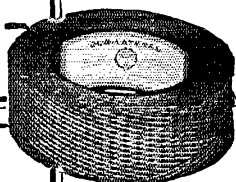

PACENT DUO-LATERAL COILS

PACENT Duo-Lateral Inductance Coils are specially designed for laboratories, engineers, experimenters, as well as for special circuits.

We are "Headquarters" for Duo-Lateral Coils and carry a complete line of all standard turn ratios.

Write for information and prices.

Pacent Electric Corp., 91 Seventh Ave., N.Y. City

Hey, I am—
Have u ordered ur copy of
**Handy's
Handbook?**

THE BEST \$1 YOU EVER SPENT!

PUBLISHED BY
AMERICAN RADIO RELAY LEAGUE
1711 PARK ST. HARTFORD, CONN.

FREE Wholesale Radio Catalog

Our new 1928 catalog is jammed full of the newest offerings of nationally known radio parts, kits, sets, accessories, table and console cabinets, etc. Whatever your radio need may be it's in our 1928 catalog. Also contains *Short Wave Section* showing the finest receiving and transmitting apparatus. Write for this big catalog—and for our confidential discount sheet—but write immediately.

SHURE RADIO CO., 343 H Madison St., Chicago, Ill.

1928
WHOLESALE
RADIO
CATALOG

every one of them worth while apparatus that you would like to have in your station. Just think of it, a chance to win some valuable additional equipment and to have some good fun at the same time. You will be adding to the amateur radio prestige of your country as well as collecting a stack of new records for the shack and making some new friends.

If you can't receive on 20, 40, and 80 meters you may be handicapped in the tests. The transmitter should be able to QSY quickly from one band to another, too, if your administration permits you to use several bands and if you plan to make best use of all the operating time at your disposal. The tests open February six, so plan to do any rebuilding necessary NOW.

Do your best in the February tests. Let's have a report of each and every score for QST however large or small it may be. There will be more about the prizes in an early issue and as complete a report after the test results are in as possible giving credit to everyone. Luck and 73. Be ready for action at 0000 GCT February 6 and don't forget to report promptly at the end of the tests.

Calls Heard

(Continued from page 53)

ek-4dba ek-4jl em-smuk en-Oga ep-lae ep-3co fm-8vx fm-ocrb fo-a4l fm-a4x nc-1co nc-2cg nc-2fo nc-5yo nc-5go nj-2pz nm-9a oa-2bb oa-2rc oa-2rt oa-2rx oa-2rw oa-3my oa-3wm oa-3xo oa-4an oa-5by oa-5dx oa-7ew oa-7ex oa-7hl oz-2ae oa-3ai sg-cb5 sa-dh2 sa-fb5 sa-hd4 sb-lab sb-lak sb-lam sb-lap sb-lar sb-lat sb-lbk sb-lbr s-1ib sb-2am sb-2ig sc-2af sc-2ab sj-1rd su-2ak.

Heard on KOGP at San Juan, P. R., by nu5SR-5PG

1acm 1amu 1ank 1bak 1bbo 1cdp 1ck 1enf 1mv 1lp 1pf 1xl 1xy 2abe 2ag 2afz 2alp 2aa 2ayj 2azw 2bfq 2bir 2bm 2bp 2bv 2cjd 2co 2cnu 2cxl 2hv 2jb 2pr 2rg 2sg 2uo 2arib 3apq 3aso 3bei 3ev 3ds 3fa 3hv 3jg 3qt 3xav 4abe 5ajj 5akk 5amf 5ao 5aov 5aow 5apm 5arg 5ary 5gr 5ig 5kl 5ns 5pk 5rg 5rv 5vf 6am 6be 6bur 6cgr 6is 7cm 7erp 7lm 7ya 8azj 8akv 8alu 8aze 8bhg 8hek 8brf 8brz 8ct 8cjl 8sz 8lf 9aa 9ar 9as 9ayl 9bjl 9cdf 9cfn 9cim 9cmz 9cuc 9duu 9dmm 9dku 9dr 9dte 9dwo 9ehr 9ekw 9ena 9enr 9ext 9xl na-9hb nm-9a ns-8doi nq-2jt nc-2bb nq-2fg nm-1aa.

KUJX, S.S. Liberty Bell, QSL, nu9DPX, 1795 Lincoln Ave., St. Paul, Minn.

Between New Orleans and Genoa, Italy

R. J. Cotton, Opr.

(October 2 to October 26)

Cape Hatteras to Azores Islands

(20 meters)

1ry 1sw 1sz 1zz 1amc 1awe 2fu 2jn 2agn 4qb 5zav 8ve 8adg 8ayu 8azo 9mh 9adz 9baf 9eag nc-2al nc-4fv eb-4rs ef-8fd sb-1aa sb-lak wnp.

(40 meters)

1ag 1ck 1di 1fl 1fs 1gp 1im 1in 1ka 1lc 1lp 1kh 1my 1rf 1ue 1ut 1vs 1xy 1yb 1adl 1agc 1aqi 1aqp 1ara 1ask 1atr 1auk 1awm 1adz 1azw 1bak 1bbe 1bed 1bjj 1bke 1bsd 1bvb 1bvl 1ckp 1cmf 1cpd 2ag 2bm 2bv 2ev 2fw 2iz 2kg 2kl 2md 2nm 2ns 2qs 2rs 2sb 2sz 2tm 2tr 2ub 2uo 2vm 2vt 2abp 2acd 2afv 2agb 2agn 2ags 2ahj 2ain 2aio 2aib 2aui 2amt 2apd 2aqz 2arb 2asb 2ase 2atr 2aub 2auv 2avi 2avq 2awi 2ayi 2ayj 2bao 2baz 2bdf 2bdi 2beo 2bgh 2bme 2bni 2cdr 2cjo 2erb 2eug 2ag 3au 3bk 3ec 3cf 3dj 3ep 3gi 3id 3mb 3nj 3pr 3qi 3rb 3su 3vf 3abo 3afw 3afx 3ahl

VITROHM Transmitting Grid Leaks and Rheostats now cover the entire line of transmitting tube circuits. ¶The prices on these amateur products are reduced materially. ¶Your dealer should stock Vitrohm Transmitting Products. ¶If you have difficulty in obtaining them, write us direct.

CATALOGUE NUMBER	PRODUCT	RESISTANCE	DISSIPATION	CURRENT	MAX. TUBE RATING	PRICE
507-2	Grid Leak*	5000 ohms	44 watts	90 m.a.	100 watts	\$2.00
507-3	Grid Leak*	5000 ohms	200 watts	200 m.a.	1000 watts	2.80
507-4	Grid Leak†	50,000 ohms	200 watts	60 m.a.	1000 watts	6.50
507-5	Grid Leak†	20,000 ohms	200 watts	100 m.a.	1000 watts	4.25
507-51	Grid Leak*	10,000 ohms	200 watts	135 m.a.	1000 watts	4.00
507-66	Grid Leak**	15,000 ohms	200 watts	120 m.a.	1000 watts	6.00
507-63	Rheostat†*	50 ohms	50 watts	1 amp.		5.50
507-59	Rheostat*†	20 ohms	80 watts	2 amp.		5.50
507-83	Rheostat*†	12.5 ohms	60 watts	2.2 amp.		5.50

* Center-tapped
 † DeForest P or R. C. A. 852 Tube
 De Forest H Tube

** Steps at 5M—10M—15M
 for R. C. A. 852 or DeForest P Tube
 †† For Primary Control
 *† Filament and Primary Control

Ward Leonard Electric Company

37-41 South Street

Mount Vernon, N. Y.

HIGH VOLTAGE FILTER CONDENSERS

Manufactured by Dubilier Condenser & Radio Corp.

1 3/4 mfd. 1000 volts rated D.C. Working Voltage Extra Special at \$1.35 each
 7 mfd. 600 volts. rated D.C. Working Voltage Extra Special at \$3.50 each
 3.9 mfd. 900 volts rated D. C. Working Voltage Extra Special at \$2.70 each

Manufactured by Stromberg-Carlson Tel. Mfg. Co.

3 1/2 mfd. 600 volts rated D.C. Working Voltage Extra Special at \$1.75 each

All of these High Quality Filter Condensers, are brand new, and guaranteed as rated. They are excellent for use in your Transmitter, Eliminator or Experimental Work.

AMERICAN SALES CO.

21 WARREN ST., N. Y. C.

RADIO SCHOOL

Send for Catalogue

MASSACHUSETTS RADIO and TELEGRAPH SCHOOL

NEW TERM JAN. 3

18 Boylston St.

Boston, Mass.

QUARTZ CRYSTALS

Processed For Maximum Effect

One inch sections ground to within 1% of your specified frequency:

75-100 Meters\$17.50
 100-200 Meters 10.00
 200-500 Meters 15.00

Quotations on request for sections of any practicable specifications. Thorough satisfaction guaranteed. Immediate Delivery.

John T. Rooney, Consulting Chemist, 31 Calumet Bldg., Buffalo, N. Y.
 "Ten years of Crystallographic experience"

At \$600 this famous
Cabinet
 has no equal!



THE BLUE RIDGE
 7x18x10" Mahogany or Walnut Finish

Send us your order or write for catalog and full information. 12 hour service, factory to you.

Southern Toy Co. Inc.
 Manufacturers Hickory N.C.

WHOLESALE PRICES TO HAMS



My Big 1928 Radio Book contains latest developments in short wave transmitting and receiving apparatus. Remarkable advance developments. Everything for "Hams" at wholesale prices. Valuable information. Get FREE COPY.

BIG BARGAIN CATALOG

AMERICAN AUTO & RADIO MFG. CO.
HARRY SCHWARTZBERG, PROP.
Dept 189 American Radio Bldg., Kansas City, Mo. **FREE**

A Laboratory Product



**CRESCENT
LAVIE
RESISTANCES**

For Distortionless Amplification

12,000, 48,000, 60,000, 100,000 Ohms, List \$1.50 each. Special Sizes to Order, \$2.50 each. Dealers write for discounts. When Better Resistances are made they will be Crescents.
Cresradio Corp., 166-32 Jamaica Ave., Jamaica, N. Y.

Kenotron Rectifying Tubes

(Type T. B. I.)

MFD. BY GENERAL ELEC. CO



These rectifying tubes operate on a filament voltage from 8 to 10 Volts and draw 1 1/4 amps. They will safely stand an A.C. input voltage up to 750 Volts and pass plenty of current and voltage for the plate of the Transmitting Tubes.

They are also very efficient rectifiers for use in "B" Battery Eliminators.

STANDARD BASE
NEW IN ORIGINAL CARTONS

PRICE ONLY \$1.25 Ea.

AMERICAN SALES COMPANY, 21 Warren St., N.Y.C.

**Hey,
I am—
Have u ordered ur copy of
Handy's
Handy
Handbook?**

THE BEST \$1 YOU EVER SPENT!

PUBLISHED BY
AMERICAN RADIO RELAY LEAGUE
1711 PARK ST., HARTFORD, CONN.

A. R. R. L. Members -- What about your friends?

You must have a friend or two who ought to be members of our A.R.R.L., but aren't. Will you give us their names, so that we may write to them and tell them about the League and bring them in with the rest of us? The A.R.R.L. needs every eligible radio enthusiast within its ranks, and you will be doing your part to help bring this about by recommending some friends to us. Many thanks.

American Radio Relay League,
Hartford, Conn.

.....1928

I wish to propose

Mr.of

Mr.of

Street & No. Place State

for membership in the A.R.R.L. I believe they would make good members. Please tell them the story.

.....
.....

Seventh Edition Just Off the Press

ROBISON'S MANUAL OF RADIO TELEGRAPHY AND TELEPHONY

Completely Revised and Up-to-Date

Of the 6th edition of this book reviewed by QST it was said this is perhaps

"The Best Radio Book That Ever Came To This Desk"

The standard Navy book on radio originally prepared in 1907 by Lieutenant (last year Admiral and C-in-C of U. S. Fleet) S. S. Robison. The 6th edition and the present edition revised by Commander S. C. Hooper, U. S. Navy, late Radio Officer, U. S. Fleet.

Price \$5.50 postpaid (former edition sold for \$8.00)

Address: Secretary-Treasurer, U. S. Naval Institute, Annapolis, Md., U. S. A.

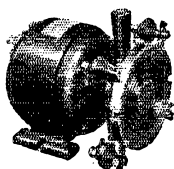

Get the ADVANCE "Sync" RECTIFIER

GET this improved "Sync" Rectifier. Superiority proven by its prevailing use in international transmitting. Lower in price in spite of higher quality.

The Advance Sync Rectifier meets all requirements for heaviest duty. Improves all transmission—giving clearer tone and better volume. Can be easily and quickly filtered.

Speedy starting. Requires no attention—always ready. With 1/4 H.P. Westinghouse motor, \$55.00 complete.

Get the best. Write now for free descriptive folder

ADVANCE ELECTRIC COMPANY
1260-1262 West Second St., Los Angeles, Calif.

To Our Readers Who Are Not A. R. R. L. Members

Wouldn't you like to become a member of the American Radio Relay League? We need you in this big organization of radio amateurs, the only amateur association that does things. From your reading of *QST* you have gained a knowledge of the nature of the League and what it does, and you have read its purposes as set forth on page 6 of every issue. We would like to have you become a full-fledged member and add your strength to ours in the things we are undertaking for Amateur Radio, and incidentally you will have the membership edition of *QST* delivered at your door each month. A convenient application form is printed below—clip it out and mail it today.

.....1928
American Radio Relay League,
Hartford, Conn., U. S. A.

Being genuinely interested in Amateur Radio, I hereby apply for membership in the American Radio Relay League, and enclose \$2.50 (\$3 in foreign countries) in payment of one year's dues. This entitles me to receive *QST* for the same period. Please begin my subscription with the issue. Mail my Certificate of Membership and send *QST* to the following name and address.

.....
.....

Station call, if any

Grade Operator's license, if any

Radio Clubs of which a member

Do you know a friend who is also interested in Amateur Radio, whose name you might give us so we may send him a sample copy of *QST*?.....

..... Thanks!

CROSLLEY
AC BANDBOX

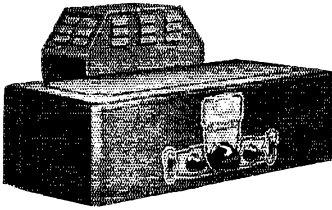

\$110

Without
Tubes

With the acquisition of a license by The Crosley Radio Corporation under a large group of patents controlled by The Radio Corporation of America, American Telephone and Telegraph Company, General Electric Company, Westinghouse Electric and Manufacturing Company, etc., the Crosley AC Bandbox is possible through the use of the new H. C. A. alternating current tubes—UX 226 and UX 227. These tubes utilize for their filaments and heating regular alternating current from the householding circuit.

The Crosley AC Bandbox with the new alternating current tubes is truly revolutionary, and brings to the radio user an entirely new conception of care-free radio. This AC model together with the battery type BANDBOX which works with standard power supply units and storage batteries is the country's most talked of radio! Sold at all Crosley Authorized dealers. If you cannot locate one, write Dept. 18 for his name and literature.

The Crosley Radio Corporation
Powell Crosley, Jr., Pres. Cincinnati, Ohio
Montana, Wyoming, Colorado, New Mexico and West, prices slightly higher.

CROSLLEY
RADIO

Crosley is licensed only for Radio Amateur, Experimental, and Broadcast Reception.



eg2ASL, 124 Eversleigh Rd., Battersee, London, Eng.

1abd 1abk 1abp 1aci 1acm 1ape 1agl 1ahx 1akm 1anz
1aql 1ar 1aqt 1arz 1as 1asf 1ati 1atf 1bat 1bb
1bcn 1bd 1bke 1bhs 1bms 1bnh 1bqs 1br 1bs 1can
1cew 1cop 1ed 1cjf 1cmf 1fl 1fq 1ga 1lx 1mf 1moa
1nx 1po 1ql 1qv 1ry 1vc 1xv 2abe 2abw 2adl 2adu
2aff 2af 2afv 2agb 2agp 2agw 2agu 2ah 2aha 2ahb
2ahi 2alu 2ang 2ary 2ase 2asa 2at 2ats 2aun 2auq
2ayk 2au 2awi 2awq 2ayj 2az 2bad 2bat 2bbc 2bes
2bcb 2ber 2bez 2bfy 2bwv 2bs 2cjd 2cms 2cod 2cox
2cob 2cr 2cty 2cuz 2cux 2cys 2cw 2czr 2dr 2hr
2kg 2mb 2iz 2qh 2qi 2or 2oe 2sg 2sj 2tr 2uy 2vq
2za 2af 2aef 2aes 2aed 2aep 2ajh 2afu 2aih 2aiv
2ali 2avw 2au 2bms 2bop 2bq 2bqi 2bqp 2bqz 2bz
2bc 2cd 2chg 2ctb 2cgl 2cgr 2cc 2fc 2hh 2ib 2hu
2jm 2ke 2kn 2mw 2mv 2mb 2nj 2pr 2pa 2ow 2qc
2qp 2vx 2zc 2ab 2af 2cl 2cy 2ek 2du 2it 2iz 2jd
2js 2jo 2jw 2ok 2oh 2ok 2pf 2qk 2qz 2rk 2rn 2rr
2tn 2um 2uo 2th 2vo 2abp 2ajk 2ayl 2cl 2dl 2di 2dk
2nl 2oa 2ql 2ala 2gr 2rd 2zay 2af 2ul 2uk 2uv 2wo
2wx 2ud 2axn 2ij 2dhi 2aj 2aj 2aid 2ak 2au 2am
2ax 2aya 2ax 2axh 2axi 2axj 2axk 2axl 2axm 2axn
2axo 2axp 2axq 2axr 2axs 2axt 2axu 2axv 2axw 2axx
2axy 2axz 2ba 2bb 2bc 2bd 2be 2bf 2bg 2bh 2bi 2bj
2bk 2bl 2bm 2bn 2bo 2bp 2bq 2br 2bs 2bt 2bu 2bv
2bw 2bx 2by 2bz 2ca 2cb 2cc 2cd 2ce 2cf 2cg 2ch
2ci 2cj 2ck 2cl 2cm 2cn 2co 2cp 2cq 2cr 2cs 2ct
2cu 2cv 2cw 2cx 2cy 2cz 2da 2db 2dc 2dd 2de 2df
2dg 2dh 2di 2dj 2dk 2dl 2dm 2dn 2do 2dp 2dq 2dr
2ds 2dt 2du 2dv 2dw 2dx 2dy 2dz 2ea 2eb 2ec 2ed
2ee 2ef 2eg 2eh 2ei 2ej 2ek 2el 2em 2en 2eo 2ep
2eq 2er 2es 2et 2eu 2ev 2ew 2ex 2ey 2ez 2fa 2fb
2fc 2fd 2fe 2ff 2fg 2fh 2fi 2fj 2fk 2fl 2fm 2fn 2fo
2fp 2fq 2fr 2fs 2ft 2fu 2fv 2fw 2fx 2fy 2fz 2ga 2gb
2gc 2gd 2ge 2gf 2gg 2gh 2gi 2gj 2gk 2gl 2gm 2gn
2go 2gp 2gq 2gr 2gs 2gt 2gu 2gv 2gw 2gx 2gy 2gz
2ha 2hb 2hc 2hd 2he 2hf 2hg 2hh 2hi 2hj 2hk 2hl
2hm 2hn 2ho 2hp 2hq 2hr 2hs 2ht 2hu 2hv 2hw 2hx
2hy 2hz 2ia 2ib 2ic 2id 2ie 2if 2ig 2ih 2ii 2ij 2ik
2il 2im 2in 2io 2ip 2iq 2ir 2is 2it 2iu 2iv 2iw 2ix
2iy 2iz 2ja 2jb 2jc 2jd 2je 2jf 2jg 2jh 2ji 2jj 2jk
2jl 2jm 2jn 2jo 2jp 2jq 2jr 2js 2jt 2ju 2jv 2jw 2jx
2jy 2jz 2ka 2kb 2kc 2kd 2ke 2kf 2kg 2kh 2ki 2kj
2kl 2km 2kn 2ko 2kp 2kq 2kr 2ks 2kt 2ku 2kv 2kw
2kx 2ky 2kz 2la 2lb 2lc 2ld 2le 2lf 2lg 2lh 2li 2lj
2lk 2ll 2lm 2ln 2lo 2lp 2lq 2lr 2ls 2lt 2lu 2lv 2lw
2lx 2ly 2lz 2ma 2mb 2mc 2md 2me 2mf 2mg 2mh 2mi
2mj 2mk 2ml 2mm 2mn 2mo 2mp 2mq 2mr 2ms 2mt
2mu 2mv 2mw 2mx 2my 2mz 2na 2nb 2nc 2nd 2ne 2nf
2ng 2nh 2ni 2nj 2nk 2nl 2nm 2nn 2no 2np 2nq 2nr
2ns 2nt 2nu 2nv 2nw 2nx 2ny 2nz 2oa 2ob 2oc 2od
2oe 2of 2og 2oh 2oi 2oj 2ok 2ol 2om 2on 2oo 2op
2oq 2or 2os 2ot 2ou 2ov 2ow 2ox 2oy 2oz 2pa 2pb
2pc 2pd 2pe 2pf 2pg 2ph 2pi 2pj 2pk 2pl 2pm 2pn
2po 2pp 2pq 2pr 2ps 2pt 2pu 2pv 2pw 2px 2py 2pz
2qa 2qb 2qc 2qd 2qe 2qf 2qg 2qh 2qi 2qj 2qk 2ql
2qm 2qn 2qo 2qp 2qq 2qr 2qs 2qt 2qu 2qv 2qw 2qx
2qy 2qz 2ra 2rb 2rc 2rd 2re 2rf 2rg 2rh 2ri 2rj
2rk 2rl 2rm 2rn 2ro 2rp 2rq 2rr 2rs 2rt 2ru 2rv
2rw 2rx 2ry 2rz 2sa 2sb 2sc 2sd 2se 2sf 2sg 2sh
2si 2sj 2sk 2sl 2sm 2sn 2so 2sp 2sq 2sr 2ss 2st
2su 2sv 2sw 2sx 2sy 2sz 2ta 2tb 2tc 2td 2te 2tf
2tg 2th 2ti 2tj 2tk 2tl 2tm 2tn 2to 2tp 2tq 2tr 2ts
2tt 2tu 2tv 2tw 2tx 2ty 2tz 2ua 2ub 2uc 2ud 2ue
2uf 2ug 2uh 2ui 2uj 2uk 2ul 2um 2un 2uo 2up 2uq
2ur 2us 2ut 2uu 2uv 2uw 2ux 2uy 2uz 2va 2vb 2vc
2vd 2ve 2vf 2vg 2vh 2vi 2vj 2vk 2vl 2vm 2vn 2vo
2vp 2vq 2vr 2vs 2vt 2vu 2vv 2vw 2vx 2vy 2vz 2wa
2wb 2wc 2wd 2we 2wf 2wg 2wh 2wi 2wj 2wk 2wl
2wm 2wn 2wo 2wp 2wq 2wr 2ws 2wt 2wu 2wv 2ww
2wx 2wy 2wz 2xa 2xb 2xc 2xd 2xe 2xf 2xg 2xh 2xi
2xj 2xk 2xl 2xm 2xn 2xo 2xp 2xq 2xr 2xs 2xt 2xu
2xv 2xw 2xx 2xy 2xz 2ya 2yb 2yc 2yd 2ye 2yf 2yg
2yh 2yi 2yj 2yk 2yl 2ym 2yn 2yo 2yp 2yq 2yr 2ys
2yt 2yu 2yv 2yw 2yz 2za 2zb 2zc 2zd 2ze 2zf 2zg
2zh 2zi 2zj 2zk 2zl 2zm 2zn 2zo 2zp 2zq 2zr 2zs
2zt 2zu 2zv 2zw 2zx 2zy 2zz

eg2BVG, R. S. Foskett, 48 Woodland Ter., Lond. SE7
1asf 1bbo 1cfo 2vzv 2cjj 5ara 8avc 8avk 8emo 9ell.

eg2HJ, K. E. B. Jay, 19 Elm Close, Amersham,
Bucks, England
(20 meters)

1aal 1aba 1aep 1ait 1akz 1apv 1awe 1ba 1bbs 1bux
1bw 1byv 1bzj 1cmx 1fl 1ia 1mf 1rd 1ry 1sw 1sz 1xi
1zad 2aep 2aes 2aiu 2bev 2bg 2bzc 2ebo 2fn 2gp 2md
2tp 2vs 2xad 2adm 2ank 2akw 2cfj 2gp 2iq 2nq
2rq 2dv 2rm 2ara 2jr 2zav 2adg 2agi 2axa 2ayu
2bub 2cbi 2cmo 2cug 2dj 2dp 2fa 2fb 2gm 2hvy 2hws
2che 2cu 2ib 2uy 2c-lap 2c-lar 2c-lbr 2c-2al 2c-2bl
2c-4dp 2c-8wg 2p-4sa 2b-law 2b-lib 2wp 2ex-ocp.

(40 meters)

2ahl 2apn 2auw 2bms 2bqp 2bqv 2bwt 2bcm 2cbr
2ceb 2chg 2cki 2ckl 2cp 2hh 2jm 2jn 2id 2iv 2mv
2ng 2pr 2ah 2aa 2ag 2af 2wj 2wm 2xav 2ee 2fc
2fu 2ge 2jd 2jw 2km 2kl 2ll 2nl 2nq 2oc 2oh 2ok
2oo 2rn 2si 2tu 2vh 2ws 2ao 2av 2dl 2he 2ki 2zav
2du 2bmm 2bwo 2bxi 2bxy 2cjh 2cn 2cnc 2cp 2cpd
2cpq 2cbr 2crj 2dku 2r 2de 2eac 2egh 2ell 2ep 2fs
2jk 2lz 2pm fi-lcw fi-pm 2c-lbr 2c-2bc 2c-2bg 2c-3uc
2m-9a 2m-1nic 2q-2ac 2q-7cx 2r-2fz 2a-2cm 2a-2fc
2a-2rb 2a-2ro 2a-2vi 2a-2bq 2a-2es 2a-2ls 2a-2wm 2a-2bq
2a-2ch 2a-2cw 2a-2gd 2a-2hl 2a-2lj 2a-2bc 2a-2ae
2z-2at 2z-2bg 2z-2bp 2z-2ae 2z-2ap 2z-2ar 2z-2au
2z-4aa 2z-4ae 2a-cb5 2b-1ah 2b-law 2b-lcm 2b-1cg 2b-2al
2b-2as 2b-2ba 2c-2ah 2s-2bn 2wp 2arx 2xi-lrp.

R. A. Rowden, 12 Pennsylvania Rd., Exeter, England
1ach 1ag lanw 1anz 1aoh 1awe 1awd 1bky
1byx 1cjc 1ecz 1cmf 1om 1ej 1xv 2adl 2afb 2arf
2amd 2ami 2aub 2axl 2ayi 2bbc 2lh 2kr 2or 2qf
2tr 2afu 2afv 2ahr 2alq 2ant 2bgg 2bgs 2bms 2bwt
2caq 2cgf 2ckl 2cp 2ec 2hu 2lg 2mv 2ub 2uc 2vj
2ab 2acn 2ec 2hl 2hx 2is 2jw 2kl 2ll 2lp 2nq 2oc 2oh
2ab 2ac 2ad 2ad 2ad 2afk 2ah 2ajk 2ane 2aqf 2at
2atp 2avs 2axp 2ee 2ew 2he 2kc 2kg 2ly 2ms 2ms
2nq 2qj 2sh 2uk 2vx 2wo 2wu 2zav 2axr 2bxl 2rl 2az
2ago 2ahc 2ako 2aly 2apo 2aug 2avl 2awp 2axa 2bhz
2bsr 2civ 2cro 2crp 2cug 2cud 2dcn 2dia 2dox 2dt
2rh 2zcc 2adk 2afa 2ajj 2aue 2avv 2awz 2axb 2axo
2axu 2bal 2baz 2bel 2bej 2bfy 2bmx 2bpd 2bqv 2bsh
2buv 2bvh 2efn 2gmc 2gmw 2erj 2ev 2evn 2evy 2eyz
2dah 2dka 2dr 2drs 2dud 2dws 2bvw 2ef 2ek 2egh
2eky 2jr 2ib 2id 2iz 2pu 2ra.

400, A. K. Edgerton, 18-40 Street South,
St. Petersburg, Fla.

ef-8ba ef-8cl ef-8eo ef-8kg ef-8nn ei-1er en-oja
ewh4 fq-ocdl ne-8ae nhca nm-1lr n8na nr-cto nr-2ea
ns-8ij nu-7ab nu-7afq nu-7ail nu-7aih nu-7bm nu-7n
7iz nu7sf nx-8eq oa-2rb oa-2tm oa-3ig oa-5bj oa-5da
oa-5dx oa-5mb oa-5wp oa-7cw oa-7jk oz-1rj oz-2bp
oz-2go sb-law sb-2ag sb-2ay su-2ak wnp.

NATIONAL

Power Transformers

and Power Units for
Plate Supply

Send for Pamphlet Q-124

NATIONAL CO., INC.

W. A. Ready, Pres.

Malden, Mass.



Don't Forget

That the A.R.R.L. Emblem is the badge of every real Amateur.

It is available in various sizes for button, pin, auto or radio-mast.

"That ham may recognize ham—display the A.R.R.L. Emblem."

American Radio Relay League, Hartford, Conn.

HAM-ADS

NOTICE

Effective with the July issue of QST the policy of the "Ham Ad" Department was altered to conform more nearly to what it was originally intended that this department should be. It will be conducted strictly as a service to the members of the American Radio Relay League, and advertisements will be accepted under the following conditions.

- (1) "Ham Ad" advertising will be accepted only from members of the American Radio Relay League.
- (2) The signature of the advertisement must be the name of the individual member or his officially assigned call.
- (3) Only one advertisement from an individual can be accepted for any issue of QST, and the advertisement must not exceed 100 words.
- (4) Advertising shall be of a nature of interest to radio amateurs or experimenters in their pursuit of the art.
- (5) No display of any character will be accepted, nor can any typographical arrangement, such as all or part capital letters, be used which would tend to make one advertisement stand out from the others.
- (6) The "Ham Ad" rate is 7c per word. Remittance for full amount must accompany copy.
- (7) Closing date: the 25th of second month preceding publication date.

THE life blood of your set—plate power. Powerful permanent, infinitely superior to dry cells, lead-acid, Bs, B eliminators. Trouble-free, rugged, abuse proof, that's an Edison Steel-Alkaline Storage, B-battery. Upset electrically welded pure nickel connectors insure absolute quiet. Lithium-Potassium solution (that's no lye). Complete, knock-down kits, parts, chargers. Glass tubes, shock-proof jars, peppy elements, pure nickel, anything you need. No. 12 solid copper enameled permanently perfect aerial wire \$1.00, 100 ft. Silicon steel laminations for that transformer 15c lb. Details, full price list. Frank Murphy, Radio 8ML, 4837 Rockwood Rd., Cleveland, Ohio.

SALE—20 watt transmitter, phone and CW. Also parts. GE Dynamotor 24/1500, \$40.00. One h.p. 32 volt SC motor \$20.00. Selling on account of sickness. Wm. Hansen, Jr., Niles, Michigan.

FELLOWS we have obtained more wonderful bargains, just take a look at 'em, Navy VT14 5 walters, new and in original boxes \$1.80 each 0-10 AC filament voltmeters, flush mount \$2.25. 0-10 to 0-400 flush mount milliameters \$1.80, state range wanted. 0-500 DC voltmeters \$4.50. Amplifying transformers 5-1 \$1.10. Western Electric 500 volt 2 MFD condensers \$1.00. 30 Henry 150 milliamperes chokes \$2.50. Cardwell .00035 condensers \$1.50. Pyrex sockets 50c. Federal 2200 Ohm phones \$2.50. Large Neon tubes \$1.50. Plug-in coils 15 to 200 meters \$4.75 per set. Orders sent C. O. D. Please include postage. E. P. Hufnagel 879 So. 18th Street, Newark, N. J.

NEW Bradley radiostat, price \$5.00. John Brabson, Greeneville, Tennessee.

NEAT, accurately calibrated wavemeters in hardwood cabinet, with genuine Bakelite panel and Marco Vernier Dial. Coils wound on grooved Bakelite forms—\$7.25 each. 3/4" heavy copper tuning inductance. 4" diameter—12c per turn 3", 9c. Milliameters, 0-100, \$1.90; 0-300, \$2.75. Pure aluminum, lead, pair, complete, 1" x 4" 7c, 1" x 6" 10c. Extra heavy, 12c, 16c. Send for free catalog. William Harrison, 35 Ft. Washington Ave., N. Y. C.

ROTARY spark gaps. Motor 110-60 cycle. 15000 volt 1 kw .002 mf condenser moulded preferred 15000 volt. Any experimental electrical equipment—must be in good condition. Joseph D. Brown, 2 Colorado St., Ashtabula, Ohio.

TRADE: G. E. type dynamotor 12/550 for R.C.A. transformer UP1016 1500/3000. Geo. H. Smith, Stanislaus, Calif.

HIGH grade chokes with adjustable core to vary from 30 to 100 Henry, 150 M.A. capacity, 6000 turns and .93 watt loss Silicon core adjustment give efficient filter operation, \$5.75. Transformers—100 watt \$25-325 and 7 1/2 volts \$7.25. 50 watt 275-275 and 5 volts \$4.00. Low voltage wound to specifications \$4.50. 30H chokes—100 M. A. \$3.00. 50H chokes—100 M. A. \$3.00. 30H chokes—60 M. A. \$2.25. "BH" Raytheon kit \$16.75. 3x4 Silicon steel cores \$1.50. Write for list of meters, chokes etc. M. Leitch, South Park Drive, West Orange, N. J.

LICENSED amateurs only—Aero Short Wave Kit—\$8.18. \$60.18 Aero 7 Kit—\$36.39. \$146.34 Tyrman Ten Kit—\$87.81. \$25.00 Browning-Drake Kit—\$16.25. \$10.00 Enco 36" Cone Kit—\$6.18. \$31.00 Modern B. Eliminator, with Raytheon—\$19.23. Discounts on Cardwell (transmitting items—15%), AmerTran, Jewell (transmitting meters—25%), Thordarson, Benjamin, Samson—35%. On Sangamo, Daven, Karas, Deutschmann, Aero, Hammarlund, Kodel, Silver-Marshall, Abox, Yaxley, Bodine, Ceco Raytheon—40%. Postpaid. Our weekly data sheets give more "dope" than all radio magazines combined. Twenty weeks—\$1.00, 52 weeks—\$2.50. Over two pounds, catalog, data, circuits, prepaid—25c. Fred Luther Kline, Kent, Ohio. (Established 1920.)

FOR sale—Omniograph, 15 dials, heavy key, coil, buzzer, phone. On one base. I. J. Story, Wessington Springs, S. D.

SALE, half price or less: Remler Capacity Units, 0-5000, \$2. ea. Fada Detector Stand and extra crystals, 60c. Welding and soldering pencil with cords and clips (attach to any 6 v. battery), \$1. Baldwin Type C fones, with cushions, \$4. Rasco cord-tip jacks and tips, 3 for 30c; 12 for \$1. Cabinet 20x9x8, unvarnished clear wood, extra base and genuine h.r. panel, \$3. Marshallstat, 60c. Electrad vernier Variohm, 1/4-30 meg., 70c. Univernier geared tuning control, 300" dial, 75c. Westinghouse chydischg. ammeter, 75c. Tungar bulb 6 amp. 75 v. and porcelain socket, \$5. Remit with order. A. B. Tripp, 237 St. Helens, Tacoma, Washington.

YOUR ARRL emblem will look twice as snappy if you wear your call with it on a radio call pin attached with a gold guard chain (fraternity chapter style). Pin with chain only three bucks! 9FZ, R. C. Ballard, 306 E. Green St., Champaign, Ill.

ARN receptacles are for those baseless tubes you're using for 3/4 and 5 meter work. 75c prepaid. A. Mallins, 89 Webster Ave., Brooklyn, N. Y.

QUARTZ crystals ground to your desired frequency for use in the various amateur bands as follows. 160 meter band \$15, 80 meter \$25, 40 meter \$50. Quotations on other sizes at your request. J. C. Fountain, Radio 8IM, 3591 Springle Ave., Detroit, Mich.

THE new Kennedy 15 watt tube oscillates at 5 meters. Ideal for crystal stage. Postpaid \$6.50. Satisfaction guaranteed or refund. W. K. McCulla, Waukegan, Ill.

POWER transformers—1 kw. 2000-2500 v. each side, \$30. 100 watt 350-550 each side, \$8.50. 200 watt filament transformer 8-11 v. \$7.50. 700 watt 1000-1500 v. \$14.50. 700 watt 2000-2500 v. \$17.50. 250 watt 550-700 v. \$10.50. 250 watt 25 cycle 600-800 v. \$14.00. 700 watt 25 cycle 1000-1500 v. \$18.50. 700 watt 25 cycle 2000-2500 v. \$22.00. 200 watt 25 cycle filament transformer 8-11 v. \$11.00. 30 Henry 150 ml. choke \$10.00. F. Greben, 9CES, 1927 S. Peoria Street, Chicago, Ill.

OMNIGRAPHS, vibroplexes, "S" tubes, teleplexes natrometers, perfectographs, transmitters, receivers, chokes, meters, transformers, 50 walters, motor generators, portable superheterodynes. Bought, sold, exchanged. L. J. Ryan, 9CNS, Hannibal, Missouri.

SELL: Used Apparatus. Acme 200 watt C. W. Transformer, \$8.00. Jewell A. C. Voltmeter 0-15, \$6.00. Roller-Smith R. F. Ammeter 0-2.5, \$2.50. REL Inductance \$5.00. Condensers, Rheostats, Misc. Receiving and Transmitting equipment. 3WX, 8211 Cedar Rd. Elkins Park, Penna.

SELL—two 204s used but O. K. mountings. Priced right. Want 80 and 350 meter crystals. Fowler E. Macy, Converse, Indiana.

BARGAIN—500 volt 200 mill. 110 volt Emerson MG. \$40. John Williams, Winnfield, La.

No. 2 OMNIGRAPH with buzzer on base. Set 15 beginner dials and set 15 regular dials. \$15. prepaid. Also late Browning-Drake broadcast receiver semi finished mahogany case. Daven amplifier with two 99s two mu 20s one mu 6 power tubes thirty dollars. Gilbert Myers, Andover 4, Harvard, Cambridge, Mass.

I am not selling out, but I have a lot of stuff I don't need and want to sell. Write for list. 50N, Box 205, Montgomery, Ala.

FOR sale or will trade. Complete new mercury arc rectifier oil cooled with keep-alive transformer and reactor. 5AKY.

SELL complete transmitter or parts separately. Omniograph, wavemeter, etc. Write for list. 8BNX, 3255 Blackstone Dr., Toledo, Ohio.

FOR sale or trade for transmitter parts, one 7A Western Electric amplifier, fifteen dollars. G. N. Karnes, Seagraves, Texas.

COPPER strip. $\frac{1}{4}$ inch. Ten foot, forty cents. Harry Sonneborn, 1223 Michigan Ave., LaPorte, Indiana.

BARGAINS—W.E.212-D 250 watt tube new \$50.; W.E. 7-A amplifier with tubes \$15.; UV 203A new \$20.; R.C.A. UP 1016 power transformer \$10. Acme Plate transformer 1500 and 1000 v. 500 watt \$12.; Four fifty watt sockets \$2.; Jewell 0-5 amps antenna meter \$5.; UP 414 modulation transformer \$2.; Two Karas orthometric receiving condensers .0001 \$6.; One Leach 6 volt heavy duty relay \$10.; One UT1367 Magnetic modulator \$2.; Receiving condensers of all types and capacities, state kind wanted; Willard Storage B's 48 volt blocks 8 per block. J. C. Gill, 125 Gill Ave., Galion, Ohio: B C A.

FOR sale: Almost new Westinghouse M.G. set 1000 v. 250 watts 110 volt A.C. drive \$75.00. 2 new $7\frac{1}{2}$ watt tubes \$9.00 pair. New 200 watt transformer 550 each side 2 $7\frac{1}{2}$ volt filament windings \$8.00. Send for list. Harry Wiedeman, 6407 Central Ave., Tampa, Fla.

FOR sale—Aero two tube short wave receiver—15-130 meters, Karas condensers, Marco dials, UV712 transformer, \$25. Write Andrew Bohn, 109 $\frac{1}{2}$ Lincoln Ave., West, Fergus Falls, Minnesota.

ONE-HALE and one KW Navy Transmitters; $\frac{1}{4}$ KW portable field type; 64 feet sectional poles; small one cylinder $\frac{1}{4}$ KW 500 cycle power outfits; also four cylinder models with AC and DC outputs; $\frac{1}{2}$ to 5 KW motor generators; $\frac{1}{2}$ KW 500 cycle transformers easily tapped \$12.50. Westinghouse 27.5-350 volt and General Electric 12-350 volt .143 ampere dynamometers \$18. 6-400 volt model \$15.00 SE 1012 receivers unused minus condensers \$20.00. Wavemeters direct reading calibration no curves. \$35. Photographs. All ex-Navy material. Henry Kienzle, 501 East 84th Street, New York.

1000 volts 800 watts Esco motor 110 volts single phase, \$95.00. 400 volts 100 watts Esco couples to 220 volts 3 phase A.C. motor \$25.00. 400 volts 100 watts generator only \$8.50. 750 volts 300 watts double commutator with 110 volts single phase motor \$65.00. 2500 volts 2 kilowatt generator double commutator, couples to three phase 220 volts 1750 speed motor. Filament motor generators 50 to 200 amperes capacity. Also many others. New $\frac{1}{4}$ h.p. 110 volts 3500 speed alternating current motors \$8.50. Prices f.o.b. Chicago. James Smat, 1734 Grand Ave., Chicago, Ill.

QSL cards 2 color \$1.00 per 100. Free samples. F. L. Young, 90CA, Corwith, Iowa.

HAND calibrated filament voltmeters 0-10 v. A.C. \$1.50. Ed. Keers, 9CJR, 2300 E. Washington St., Joliet, Illinois.

WANT stedi DC note? Now ready, New Thordarson 550 volt 190 Mill center tapped and mounted plate supply completely assembled including two sockets, two UX 216 rectifiers and filter block. Lists at \$40.00. Your price \$29.75 F.O.B. W. Ryder, Jr., Stn 9 CSU Hibbing Minnesota. Write at once for dope.

RECTIFYING tubes corresponding to CX316B and CX313, \$1.85 each, Sonotron CX310, \$5.50. Nick Davanzo, 8BLD, 1107 Emma St., Youngstown, Ohio.

PURE aluminum and lead rectifier elements holes drilled brass screws and nuts, pair 1"x4" 13c, 1"x6" 15c, 1 $\frac{1}{2}$ "x6" 17c, 1 $\frac{1}{2}$ "x6" 19c. Sheet aluminum 1/16" \$1.00, lead \$1.00 square foot prepaid, \$1.00 or more. Silicon transformer steel cut to order .014" 10 lb. 25c, 5 lb. 30c, less than 5 lbs. 35c lb. .022" 5c less per lb. Not cut 2-7" wide 15c lb., minimum 10 lb. postage extra. Edgewood wound copper ribbon 7 sizes, see January QST. Air pocket and stand off insulators 25c each. 4 for \$1.00. Glazed porcelain 5 and 6 $\frac{1}{2}$ " long prepaid on 4. Electrolytic condenser parts, \$1.50 prepaid. Geo. Schulz, Calumet, Michigan.

HIGHEST quality QSL cards. As per your copy. No stock forms, all different. Write for prices and samples. 5 dial Omnigraph \$13. Want used portable typewriter, quote price and condition. SCUX, Millington, Mich.

SELL. Kennedy Universal receiver, nearly new, fifty dollars. Also other apparatus. John Longley, Courtyer Ave., Maplewood, N. J.

50 HENRY 100 milliamperer filter chokes for use in filter system of 2 UX210, 1 DeForest "H" or 1 UX852 tube. Heavy 2 inch Silicon steel core. Mica insulated heavy construction throughout, a real choke for your filter system, weight 16 pounds. \$9.35. 50 Henry 150 milliamperer chokes, same construction as above suitable for filter systems of 1 50 watt, 2 DeForest H or 2 UX852, weight 22 pounds. \$13.25. For 20 and 30 Henry chokes deduct 10% from above prices, for 100 Henry add 25%. Add postage to all of above. Nat G. Scott, New Albany, Mississippi.

POSTPAID and guaranteed brand new. R.E.L. make—Transmitting Inductances, Type L, double unit with glass coupling rods and clips, \$8.99; 50 watt sockets, \$1.89; "H" Tube mountings, \$1.89; Short Wave Coil Kits, 10 to 110 meters, \$3.75. General Radio Wavemeters, Type 358, 14 to 224 meters, \$19.25. Write for complete list. G. F. Hall, 585 West Horter St., Philadelphia, Pa.

BARGAIN—one W.E. 50 watt 211-D tube and 112-A special socket slightly used, \$15. J. Borsos, 5346 Westford Rd., Phila., Penn.

WANTED—Radio Corporation transformer UP1016. SAUE.

TWO new W.E. fifty watters, \$24.00 each. Few peanut tubes \$2.00 each. 2BYJ, Levy, 2050 69th Street, Brooklyn, N. Y.

ARE you tired of ordering from concerns who substitute cut prices and rotten service for good merchandise and quick deliveries? Try us and note the difference! A new "Hamalog", the original Ham Catalog is waiting for you, free. See our new Transmitting Filter Condensers advertised this issue. They'll stand up where others fail. Order DeForest transmitting and receiving tubes from us—we ship quickly. Latest Amateur Call Book 75c. Our No. 20 Stand-off Insulator, 20c—use it for supporting wiring and instruments, etc. Get details of our Silver Plated Short Wave Inductances. E. F. Johnson, 9ALD, Waseca, Minnesota.

HEADQUARTERS for Hams—Immediate deliveries on Mueller 150-watt input tubes \$15.00. RCA 5-wattors \$3.15. 15-dial Omnigraphs \$20.00. Aerovox 1000-volt tested 1-mfd condensers \$1.75. Potter 1-mfd 2000-volt tested condenser \$2.50. 2500-volt 1-mfd \$3.25. New "Ham-list" 4c. Robert Curtis, 1109 Eighth Avenue, Fort Worth, Texas.

CURTIS-Griffith 250-watt power-filament transformers 350-550 each side \$10.50. Thordarson power-filament transformers for 7.5-wattors \$6.90. Thordarson power transformers 350-550 each side \$11.00; 1000-1500 each side \$16.00. Edgewood Inductance 6-inch turn 12c; 4-inch 10c; 2.5-inch 7c. Aluminum square foot 85c; Lead square foot 85c. New Edition of the "Ham-list" 4c. James Radio Curtis, NU-5-A-Q-C, 1109 Eighth Avenue, Fort Worth, Texas.

QSL cards, two colors, government post cards, \$1.90 per hundred, white cards \$1.00. Real ham stationary at \$1.40 per hundred sheets and envelopes, pad form. Postage 10c. Free samples. 8DTY, 257 Parker Ave., Buffalo, N. Y.

Q S B 7—\$8.00 list Dudlo wound chokes. 50 henry, 150 milliamperer only \$2.95; Fleckheim filter condensers. 1000 v. 2 mf. \$2.25; 1000 v. 4 mf. \$4.50; 2000 v. 2 mf. \$4.25; 2000 v. 4 mf. \$5.75; Corvico No. 12 enameled antenna wire, \$0.90 100'; Pyrex insulators, 9 $\frac{1}{2}$ " \$0.46, 7 $\frac{1}{2}$ " \$1.50, 12 $\frac{1}{2}$ " \$3.50; USL S. L. F. condensers .00035, single \$1.25, double tandem \$2.50; CP. aluminum \$1.00 ft. Myra tubes. Grid and plate leads at opposite ends, \$0.95; All sizes unmounted honeycomb coils. Low prices, write for list. Please add some for postage. Articles sent COD if desired. Shipments made same day. Send your name for our bargain list. D. L. Moon, 3344 Boulevard, Jersey City, N. J.

HAMS: Here are some of our holiday specials. Power crystals. Guaranteed within 1/10 of one percent of stated frequency. 180 meter band, \$15.00; You fellows all need a good wavemeter, but a thermogalvanometer is expensive, so why not try one of our neon tube indicators. Type "A" is only \$0.85; Type "B" ultra sensitive \$1.50; Type "C" for lower power transmitters \$2.00; Acme and Cardwell Condensers .0005 \$1.50; Electrad 75 watt grid-leaks 10,000 ohm \$1.75; Complete line of transmitting and receiving apparatus, at lowest prices. Many exceptional bargains. Send for list. Articles sent COD if desired. Please include postage. G. L. Lang 2WW, 2AWH, 1128 Springfield Ave., Irvington, N. J.

QST—December 1920 to date, \$10.00. Ralph Kunau, Sabula, Iowa.

GENERATORS, new 275 volt dc 120 watt gives up to 500 volts, \$8. General Electric new double current generators 600 and 8 volts \$18. 6 volt input dynamotors output 400 volts \$15. Slightly used 500 cycle generators 200 watt \$10. $\frac{1}{2}$ kilowatt \$15. 900 cycle generators \$10. 900 cycle dynamotors 16 volts drive \$15. 120 volt dc drive 500 cycle new motor-generators $\frac{1}{2}$ kw and 1 kw microphones \$1.25. Vt ones \$1. Send stamp for list. express collect. R. Wood, 46-20 102nd St., Corona, N. Y.

QSL cards—150, two colors, \$1.20; 150 government cards, \$2.50; Ham stationary, radiogram blanks, etc. H. M. Selden, Cranesville, Pennsylvania.

SEE these January specials; Cunningham CX 310's for \$6.82, here's your chance. Also Radiotron Model UV

202 5 watters at \$2.25 each. Get the new Power Clarostat for smooth filament control, will handle lots of power \$3.35. Twin Coupler short wave kit, tunes from 18-220 meters, space wound only \$4.93 per set. Everything sent prepaid. Send for our Bargain List. Bernard Mitchell 3520 Sheridan Rd., Chicago, Ill.

POSTPAID Bargains. All goods new. Aero receiving coils \$8.75. Aero Transmitter coil Kits \$8.95. Majestic B Eliminators \$22.50. Sonatron 7½ watters \$5.25. Karas receiving condensers \$4.75. Baldwin Phones \$6.80. Special offer—Receiving coils that can't be beat for looks or dx performance, complete for 20-40-80 \$7.25. Money back if dissatisfied. W. B. Weinacht, 7515 East End Ave., Chicago, Ill.

FOR sale—two new Sonatron 210s, \$5.75 each. 9DYM, 2019 Sherman St., Anderson, Indiana.

AMATEUR station equipment; factory job on specials. Stamp brings details free calibrated wavemeter offer. Roger Curran, Dundee, N. Y.

ACCURATE millimeters, 0-100, \$2.00, 0-300, \$3.00, 0-400, \$3.25. Motor generators, 500 volt, 150 watt. RCA UX201-As, \$1.19. UX210s, \$6.90, UX200s, \$1.50, UV202s, \$3.05. Power, filament transformers, Silver Marshall for UX210s, \$6.25 for UV203-As, \$9.00. Power chokes 30 henrys. 100 milliamperes \$2.50, 30H. 150 milliamperes, \$4.75. Imported 10 watters, \$4.90. Fifties, \$9.00. Grid leaks for fifties, \$1.84. Rectifier elements, aluminum lead, pair, 1"x4", 7c, 1"x8" 10c. Calibrated wavemeters, 17-160M, \$5.00. QSL cards, \$1.00 per 100, two colors, Free samples, radio catalogue free. William Green, 207 Cathedral Parkway, New York City.

FOR sale very cheap. 7½ w transmitter used by ORS. SCYR, complete with remote control, meters, rectifier, filter and 2 transformers. Price \$55. 2 pr. new Brandes navy phones at \$4. Federal modulation trans. \$4. QST 1924-25-26-27 in fine condition all for \$7. Carroll Henkel, Martinsburg, W. Va.

67 Ways to increase income. 96-page book Spare-time Money Handbook contains 67 practical and complete plans to operate sparetime business. For everyone who wants more money. Price only 50 cents. Ellert 693 Mission Street, San Francisco, Cal.

SELLING out. Write for list. W. E. Van Valkenburg, 1005 S. 17th Street, Fort Dodge, Iowa.

FOR sale—1 G.E. 750 watt 10000 volt transmitting tube, 2 RCA 250 watt transmitting tube, 2 W. E. 205 D tubes also sockets. 2 Thordarson microphone transformers, 1 0-15 volt A.C. Jewell voltmeter, 1 two button W.E. microphone, \$200.00 list. 3 RCA 250 watt tubes with grid leads broken suitable for rectifiers. Miscellaneous unmounted chokes. Will sell all or part. Name your price. W. F. Brink, 1442 E. Park Place, Ann Arbor, Michigan.

LOUDSPEAKER units rewound and magnets recharged \$3.00. 24 hours service. Henry Wagner, East Chicago, Indiana.

DODGE Radio Shortcut. See display section page 82 C. K. Dodge, Mamaroneck, N. Y.

Q R A SECTION

50c straight with copy in following address form only:

IBNS—Witoldo Bokanowsky, Box 1227, Jewett City, Connecticut.

IBR—M. G. McCarroll, 32 Laurel Ave., Wellesley Hills, Mass.

IWV—Miles W. Weeks, 40 Norfolk Road, Brookline, Mass.

IREU—Michael Kaplan, 9430 77th Street, Long Island, N. Y.

REL—Edward N. Dingley, Jr., 3715 Livingston St., N. W., Washington, D. C.

IADI—John Anderson Brabson, Westerly, Greeneville, Tenn.

5AEK—V. H. Thurmond, Gray County State Bank, Pampa, Texas.

6MU—San Francisco Radio Club, 454 Bright St., San Francisco, Calif.

5AFC—Paul Adanti, 33 Sheridan St., Auburn, N. Y.

SCWK—F. Kelvin Kearney, 16580 Outer Drive, Detroit, Michigan.

SRD—C. H. Vincent, Packard Motor Speedway, Utica, Michigan.

9CPH—H. L. Durlfinger, 502 Caroline St., Peoria, Illinois.

oz1FE—Alf F. Wood, P.W.D. Substation, Waihou, New Zealand.

sc1AH—C. K. Topping, Chuquicamata, Chile.

The following stations belong to members of the A.R.R.L. Headquarters gang. Mail for them should be addressed care A.R.R.L., Hartford, Conn. When operating 1MK they use personal sines as indicated.
 1MK Headquarters IBUD A. L. Budlong "bud"
 1AL H. P. Westman "wa" 1ES A. A. Hebert "ah"
 1BAO R. S. Kruse "lq" 1GO L. A. Jones "lj"
 1BDI F. E. Handy "fh" 1KP F. C. Beekley "beek"
 1BHW K. B. Warner "kb" 1OA R. S. Kruse "lq"
 1BIZ C. C. Rodimon "rod" 1SZ C. C. Rodimon "rod"

QST Oscillating Crystals

Prices for grinding POWER crystals for the various Amateur bands as follows:

150-170 Meter band	\$15.00
75-88 Meter band	\$25.00
37.5-42.5 Meter band	\$30.00

We will state the frequency of the crystal accurate to better than a tenth of one per cent. All crystals guaranteed.

BROADCAST BAND

We will grind for you a crystal accurate to plus or minus 500 cycles of your assigned frequency for \$50.00 unmounted, or \$60.00 mounted. This crystal is our POWER type and is absolutely guaranteed. PROMPT DELIVERIES.

We grind crystals to any frequency between 40 and 10,000 kilocycles. Let us quote prices for your particular requirement.

"The Crystal Specialists"

SCIENTIFIC RADIO SERVICE

P. O. Box 86 Dept. T Mount Rainier, Maryland



GRIDLEAKS

15,000 ohm, tapped at 5,000 and 10,000 ohms with 85 watt capacity	Price, \$1.50
20,000 ohms, 85 watt for UX852	1.50
5,000 ohms, 85 watts	1.00
5,000 ohms, 20 watt for one UX210	.75

Postpaid

Send for Catalogue

UTILITY RADIO CO.

80 LESLIE STREET EAST ORANGE, N. J.

\$3.50 Airplane flame proof key with blinker light; \$25.00 U. S. Signal Corps. Western Electric 8 line portable switch-board complete without battery. Cam switch operated; \$8.50 Cutting & Washington Airplane quenched spark transmitter; \$25.00 Western Electric Co. Radio Phone Transmitter & Receiver, type CW 938, oscillator, modulator and power amplifier, used with 2 V T. 2 tubes 3 V T 1 tubes detector and 2 stage amplification; \$10.00 New Portophone Airplane Telephone Outfit. 2 Helms with microphones, either crash or regular, 2 pair receivers, jack boxes, wire and instruction sheet. U. S. Air Service Equipment, Edison Storage batteries, 10 volts, 8 twin cells in case, type 1-A. Price \$5.00. Largest stock of Government Radio Transmitting and Receiving material in U. S. Send 2c stamp for our new and latest reduced price list. We ship to any part of the world. WEIL'S CURIOSITY SHOP, 29 South 2nd St., Philadelphia, Pa.

BIG NEW CATALOG FOR RADIO BUILDERS

FREE My big 1928 Radio Catalog, Call Book and Trouble Finder. 132 pages about

Radio. Chock full of newest circuits—kits, transmitter parts, short wave outfits, eliminators and speakers. Thousands of bargains at lowest wholesale prices. A regular Radio Encyclopedia—Free. Write today.

American Auto & Radio Mfg. Co.
 LARRY SCHWARTZBERG, PRES.
 Dept. 185 American Radio Bldg., Kansas City, Mo.

LATEST RADIO CIRCUITS



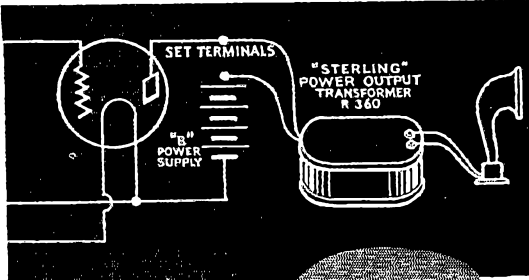

**Don't
burn
out
your
Loudspeaker!**



*make it more responsive
to weak signals—IM-
PROVE TONE QUALITY
—eliminate tube noises.*

THE STERLING POWER OUTPUT TRANSFORMER connected between the radio set and the loud speaker absolutely prevents the high voltages now delivered by "B" Power Units from ruining the speaker and large "B" Batteries make it necessary to protect the loudspeaker from damage.

This transformer is more than a protective device—it permits closer adjustment of speaker diaphragm increasing its sensibility to weak signals—prevents shocks when using headphones—eliminates tube noises and IMPROVES TONE QUALITY OF THE SPEAKER. Attach in two minutes, leave permanently connected. Price \$5.00.

Sterling

**POWER OUTPUT
TRANSFORMER**

STERLING "B" POWER VOLTMETER



A high resistance voltmeter specially designed for accurate testing of high voltage outputs of "B" Power Units, heavy duty "B" batteries and all D. C. Circuits up to 300 volts. Indispensable for every amateur—a low priced, accurate meter.

R-415
\$8.50

THE STERLING MFG. COMPANY

2331 Prospect Ave.,

Cleveland, Ohio

**FOR YOUR CONVENIENCE
QST'S INDEX OF ADVERTISERS
IN THIS ISSUE**

Acme Apparatus Company	1
Acme Wire Company	58, 70
Advance Electric Company	89
Aero Products, Inc.	6, 3rd cover
Aerovox Wireless Company	79
Allen-Bradley Company	56
Aluminum Company of America	67
American Auto & Radio Mfg. Company	87, 93
American Mechanical Laboratories	60
American Sales Company	31, 85, 87
American Transformer Company	83
A.R.R.L. Apparatus	77
A.R.R.L. Application Blank	89
A.R.R.L. Emblem	90
A.R.R.L. Handbook	75, 87, 88, 84
A.R.R.L. Recommendation Blank	87
Aurlena, Inc., Ad.	74
Burgess Battery Co.	4th cover
Burton-Rogers Company	84
Cardwell Mfg. Corp., Allen D.	2, 3
Central Radio Labs.	79
Chicago Radio Apparatus Co.	86
Cresradio Corp.	87
Crosley Radio Corp.	90
Cunningham, Inc., E. T.	2nd cover
Deutschmann Company, Tobe	72
Dodge, C. K.	82
Dongan Electric Mfg. Co.	80
Dubilier Condenser Corp.	65
Eastern Radio Institute	88
Electric Specialty Company	81
Ensell Radio Laboratory	74
Fansteel Products Company	76
Flechthelm & Company, Inc., A. M.	80
Formica Insulation Company	95
Frost, Inc., Herbert H.	72
General Radio Company	69
Grebe & Company, Inc., A. H.	8
Gross & Company, J.	79
Gulf Radio School	80
Hardwick, Field, Inc.	82
Hull & Company, S. W.	86
Jewell Electrical Instrument Co.	63
Johnson Company, E. P.	78
Karas Electric Company	66
Leeds Radio Company	68
Loomis Publishing Co.	86
Massachusetts Radio & Telegraph School	95
National Company, Inc.	90
National Radio Tube Company	62
Paent Electric Company	84
QST Binders	78
Radio 2MA Company	64
Radio Engineering Labs.	61
Ramsey Publishing Co.	64
Raytheon Mfg. Company	59
Rectifier Engineering Service	28
Rooney, John T.	85
Sangamo Electric Company	76
Scientific Radio Service	92
See Jay Battery Company	68
Shure Radio Company	84
Southern Toy Company	85
Sterling Mfg. Company	91
Stromberg-Carlson Telephone Mfg. Co.	71
Telenix Company	78
Thordarson Electric Mfg. Company	57
United States Naval Institute	30
United States Radio Sales Co.	86
Utility Radio Company	63
Vibroplex Company	88
Ward Leonard Electric Company	85
Warren Electric Company	83
Well's Curiosity Shop	93
Western Radio Mfg. Company	82
Weston Electrical Instrument Corp.	55
Wireless Specialty Apparatus Co.	96
W-L Radio Laboratories	66

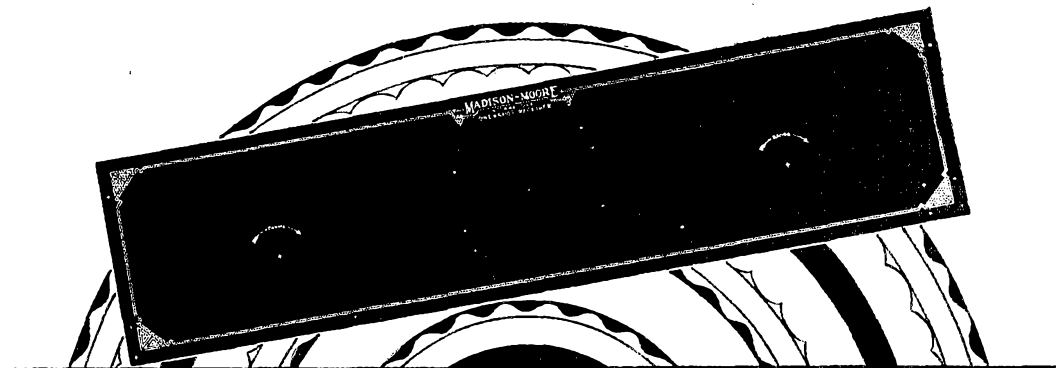

New Formica Kit Panels

RECENT additions to the list of handsomely decorated panels for famous kits include the Madison Moore International One Spot (A. C.) E. T. Flewellings Super Eight, and the new B*T Power Six Electric Kit. There are also front and sub panels for Karas (two dial), World's Record Super Ten; Camfield Nine; Tyrmann; Magnaformer, H. F. L. Victoreen and many others.

These panels are sold by all leading jobbers

The Formica Insulation Company

4618 Spring Grove Avenue Cincinnati, Ohio

Any jobber or dealer
can get Formica pan-
els for you.

FORMICA

Formica has a com-
plete insulating service
for manufacturers

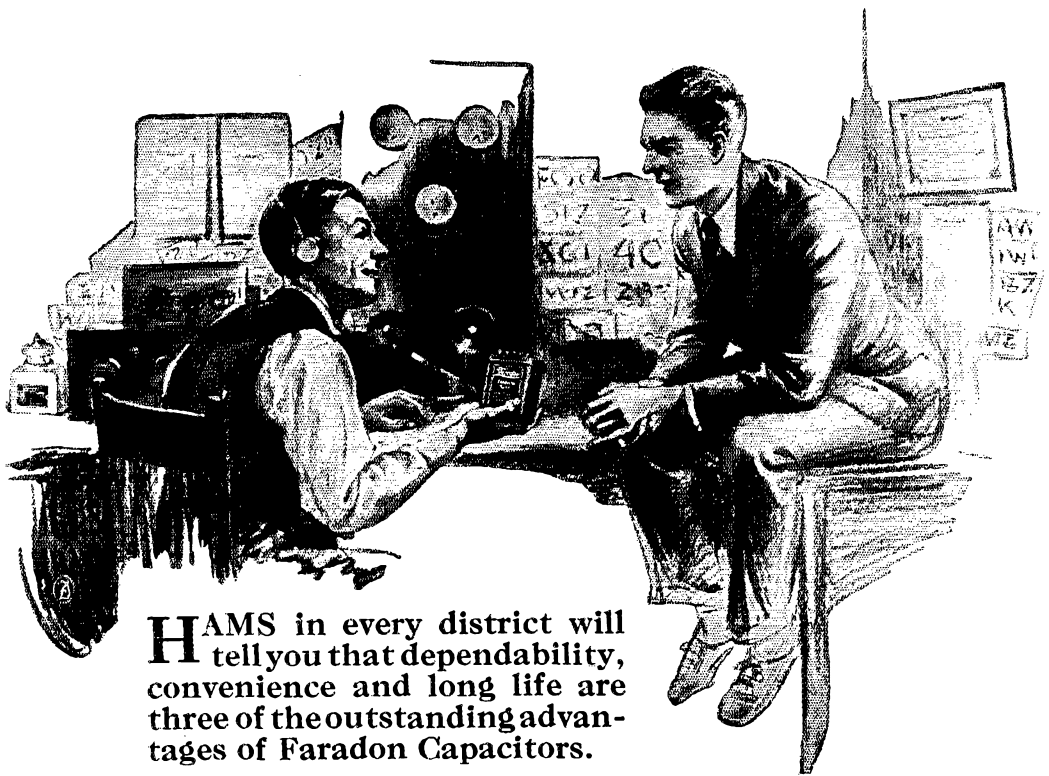

HAMS in every district will tell you that dependability, convenience and long life are three of the outstanding advantages of Faradon Capacitors.

When buying fixed condensers, for kits, or replacement, make sure that you get Faradon—the choice of men who know radio.

There is a high grade radio dealer near you who carries Faradon Capacitors in the capacitances you want, or if more convenient, write us direct.

*The
choice of
men who
know*

**WIRELESS SPECIALTY
APPARATUS COMPANY**

Jamaica Plain - Boston, Mass., U. S. A.

Established 1907

Faradon

Electrostatic Condensers for All Purposes

AERO COIL

SUPER-SENSITIVE INDUCTANCE UNITS

The Perfect Inductances for All Low Wave Work

**FOR
RECEIVING**

AERO LOW WAVE TUNER KIT

Price \$12.50

Completely interchangeable. Adopted by experts and amateurs everywhere. Range 15 to 130 meters. Includes 3 coils and base mounting, covering U.S. bands, 20, 40 and 80 meters. You can increase or decrease the range of this

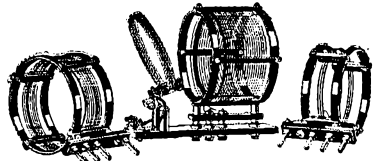

PRICE \$12.50

short wave tuner by securing the AERO Interchangeable Coils described below. All coils fit the same base and use the same condensers. Use Code No. INT-125 in ordering.



INTERCHANGEABLE Coil No. 0

Range 13 to 29.4 meters. This is the most efficient inductance for this low band. Code number INT-0.

Price \$4.00

INTERCHANGEABLE Coil No. 4

Range 125 to 250 meters. Fits same base supplied with low tuner kit. Code number INT-No. 4.

Price \$4.00

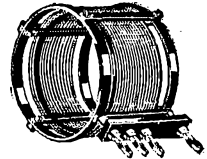

THE NEW AERO INTERCHANGEABLE COIL No. 5

Normal range 235 to 550 meters. However, by using .0001 Sangamo fixed condenser across the rotor and stator of the .00014 variable condenser, the maximum wave band of this coil is increased to 725 meters. This gives you coverage of the following bands: Airplane to Airplane, Land to Airplane, Ship to Shore (Great Lakes) Ship to Shore (Atlantic and Pacific Oceans). Code number INT-No. 5.

Price \$4.00

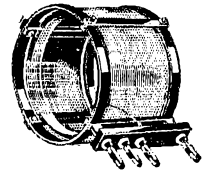

**FOR
TRANSMIT-
TING**

KEY 2040 KIT

Price \$12.00

Kit contains 2 AERO Coils, 17 to 50 meters each, 1 AERO Antenna Coil Mounting Base, 1 AERO Grid Coil Mounting Base, 2 AERO Essential Choke Coils.

KEY 1080 KIT

Price \$12.00

Kit contains 2 AERO Coils, 36 to 90 meters each, 1 AERO Antenna Coil Mounting Base, 1 AERO Grid Coil Mounting Base, 2 AERO Essential Choke Coils.

KEY 9018 KIT

Price \$12.00

Completely interchangeable with either of above kits. Range 90 to 180 meters. Contains 2 coils and mounting base.

COMPLETE AERO TRANSMITTER KITS

Complete Aero Transmitting Coils for the 20-40 and 40-80 bands, \$20.00. Complete for 20-40, 40-80, and 90-180 bands, \$28.00.

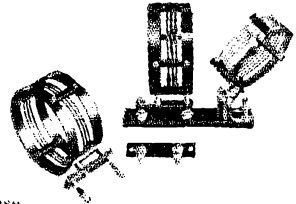

AERO PARTS

Transmitter coils (17 to 50 meters, Key 2040C, 36 to 90 meters, Key 4080C and 90 to 180 meters, Key 9018C) \$4.00 ea.
Antenna Base, Key PRI-300, \$3.00 ea.
Grid Coil Base, Key GRID-100, \$1.00 ea.
Choke Coils, \$1.50 ea.

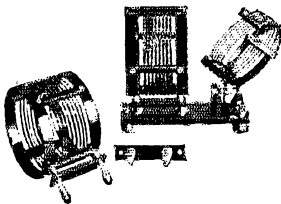

PLAN FOR D. X. RECORDS NOW!

Order these coils direct from us if your dealer hasn't them and start now for wonderful records. Specify code or key numbers when ordering. Or write at once for complete descriptive literature.

AERO PRODUCTS, Inc.

1772 WILSON AVE., CHICAGO, ILL.

Dept. 16

BURGESS

What's in a Name?

That depends on what is back of it

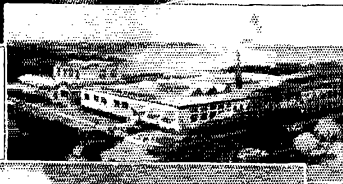
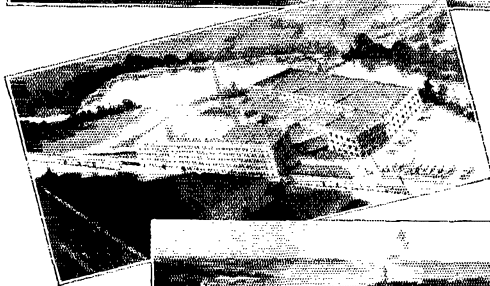
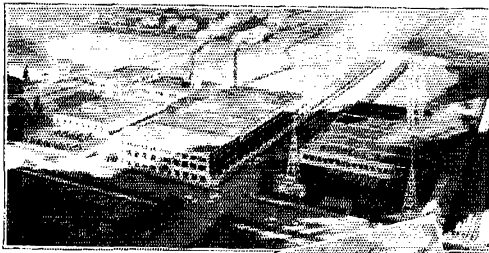

The four Burgess Plants:

Madison, Wisconsin
Freeport, Illinois
Niagara Falls, Ontario
Winnipeg, Manitoba

The name Burgess has a real background. The Burgess Battery Company has come to be one of the outstanding figures in the dry battery field. Burgess Batteries for years have been recognized as a standard of quality. They have been selected for use on expeditions to all corners of the globe where dependability was an absolute necessity. They have back of them years of scientific research and a record of satisfactory service.

And in the Amateur field Burgess Batteries stand out like a beacon light. From the days when the "Ham" game was all there was to radio right up to the present—Burgess has been a name to conjure with.

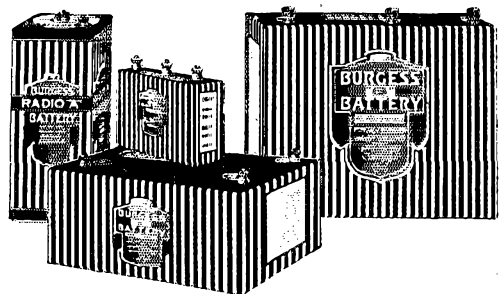

BURGESS RADIO BATTERIES

The Communications Department

F. E. Handy, Communications Manager
1711 Park St., Hartford, Conn.

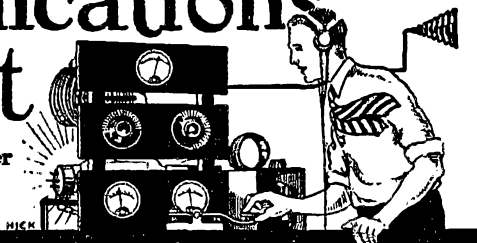

Amateur Radio Work in New England Flood

By Davis S. Boyden* and Robert D. Russell †

THE breaking down of all lines of communication between the New England flood areas and the rest of the country has again brought vividly before the people the great emergency service of which the radio amateurs of the nation are capable.

While scattered reports on the morning of November 4 told of devastation unheard of in New England, efforts from innumerable sources were being made in a frantic effort to establish communication of any kind with the stricken territory in Vermont.

Once again rose our great brotherhood of the ether, to reassure the people of this country, and of other countries, that they were ready then, as always, to give their all, for the common good. Almost immediately the Army and Navy called upon their reservists enrolled in this great multitude of radio amateurs to handle messages.

When the call came and the wires were down it was found that the radio amateurs were not only ready to try to establish communication—they were already in communication with points in the devastated area.

Few persons outside the stricken area realize how heavy the rain preceding the disaster was. It has been estimated that about seven billion tons of water fell in the drainage area of the Connecticut River alone, and this on top of one of the wettest Octobers the river valley has ever known. The cause of this torrential downpour is given in the report of the New England Weather Bureau.

"The disturbance developed over the Virginias and Carolinas Wednesday night, November 2, 1927 which emerged into a tropical storm moving generally north from Cuba. In the succeeding 24 hours it increased in energy and moved northward from Hatteras to Western New England. The central part of this storm passed northward over western Connecticut and Massachusetts early Friday morning with the barometer 29.08 at Concord N. H. and Quebec where it merged with another continental disturbance from the Lake region. High pressure over the maritime

*1st. Lieut. Sig. Res., Radio Advisor on Amateur Matters to the First Corps Area Signal Officer, nu1SL.
†Lieutenant (jg), USNR, Volunteer Communication Reserve, First Naval District.

If interested in participating in the Army Amateur Nets being formed in various parts of the country, send your application for appointment as Army Amateur Radio Station to A.R.R.L. Headquarters and it will be forwarded to the attention of the proper Corps Area Signal Officer via the Army Amateur Representative (or Radio Advisor) of that Corps Area. It is not necessary to enroll in the Signal Corps to get in on the interesting Army-Amateur activities. A QSL-card will put you in line for A.A.R.S. appointment if you have the interest and are qualified.

Address your request for information concerning or enrollment in the U.S.N.R. to Communication Division, Office of Naval Operations, Washington, D. C. Your District Commander will then be asked to get in touch with you. As soon as you are enlisted properly you can take part in the radio drills.

—F. E. H.

areas obstructed the passage of this disturbance, and forced it northward. The movement of the storm brought in large quantities of warm, moist air from the Atlantic Ocean, which was suddenly followed by the cooler air from the West, causing the torrential rain which followed. The rainfall has been officially reported from western Massachusetts in amounts as high as seven inches. High winds were general along the coast from Hatteras to Eastport, Maine, with highest velocity of 52 miles per hour at Portland, Me. The most intense rainfall occurred in central Vermont, central and southern New Hampshire, and western Massachusetts and Connecticut."

The flood conditions produced by the storm completely crippled communications, transportation and power service. The story of the loss of lives and property has been told by the press. It was the amateur radio operator and his station in this great emergency who provided the only rapid means of communication between the isolated affected area and the outside world. With practically no warning these operators were called upon to provide the necessary communications. The traffic occasioned by the flood undoubtedly would have exceeded the capacity of the normal communication systems.

The manner with which these amateurs tackled the herculean task is worthy of much praise. Some stations were put completely out of commission and many of those intact were without suitable power to operate their transmitters. Some stations were designed to operate in the forty meter band, others in the 80 meter band. While 40 meters was necessary for operation during daylight hours, it was useless for local traffic at night, due to skip distance. On the other hand 80 meters during daylight hours was not satisfactory while at night it was absolutely necessary. The story of the rehabilitation and reconstruction of these transmitters and antenna systems to successfully meet the immediate demand is a tribute to the ability and ingenuity of the amateur. Once again on the air they were confronted with a huge amount of traffic of the most important character, relief, assistance, railroad, press, personal assurances, etc. Exactness and despatch were essential. It is astonishing the number of hours of continuous operation by many stations during the interruption of commercial communications which covered periods ranging from three to ten days.

Many exciting and perilous situations were encountered by the amateurs located in the affected areas. In Montpelier, Vermont, 1-BBJ Thursday, November 3 about 3 P.M., realizing the gravity of the situation left the Machine Works, where employed, for home in his Chevrolet. The water had risen to such depths in the street that he was unable to proceed, so turned back, parked his car on high ground and attempted to walk. He had gone but a short distance when due to the depth and violent flow he was obliged to take refuge in a nearby house. Here he was marooned until the gray of dawn on the morning of the 4th when he left the house from the second story window and by boat landed on high ground. Now to get on the air as quickly and efficiently as possible. There were two active amateur stations in the city 1-BBJ and 1-BEB. They got together and decided that the latter's station

being nearer the greatest number of broadcast receivers, upon which they depended for A and B battery supply, should be the first station to get going and at about 4 P.M. 1-BEB was on the air and in contact with 8-BTO at Binghamton, New York, 1-BBJ then turned to his own station and with the cooperation of the Electric Power Company succeeded in restoring power service to his transmitters



STATION 1BBJ, MONTEPELIER, VT.

Messages received at this station were delivered by Boy Scouts. Messages to nearby towns were routed by the First Relief Expedition after receipt of same. Left to right: Ralph J. Harris of 1BEB, Montpelier; 1BBJ, George Wallstrom; H. B. Jones, who was a radio op during the war. His father, H. J. M. Jones, was Acting Food and Fuel Administrator, Montpelier, during the flood emergency. Although Mr. Jones had been out of the brass-pounding game for some time, he was of great assistance to the local amateurs.

over a line of temporary construction and got on the air on the afternoon of the 5th. Operating schedules were promptly arranged by both stations—1-BEB operating daytimes in the 40 meter band and 1-BBJ nights in the 80 meter band. Similar conditions existed at other stations.

Extracts of a letter to the A.R.R.L. from Col. Earl D. Church of The Travelers Insurance Co. go further to show this and are included in this story with his permission.

"My first contact with your League was an unusual one. I was marooned in Barre, Vermont, arriving Thursday afternoon, November 3. All telegraph and telephone wires were down, railroad tracks were washed away, bridges in every direction were gone, and so far as communication with the outside world was concerned, we might just as well have been isolated on a small island in the middle of the Atlantic.

"I was due home the next night at seven o'clock and feared the consequences if my wife got no word from me and did learn of the distressing and dangerous flood conditions. I might say some forty or fifty of us were in the same fix in the Barre hotel, and every half hour alternated in making trips to the telegraph and telephone offices. On inquiry, I learned that there was an amateur radio operator there by the name of G. E. Cruickshank, 188 South Main Street, Barre, Vermont, operating under the call letters of 1BDX. This boy was one of three caught the afternoon before in a cellar when a wall gave way and completely flooded it, and barely escaped with his life, the other two being drowned and it being impossible to get their bodies for two days afterward. He had been working steadily for nearly two days, notwithstanding which he not only willingly offered to try and get a message to Hartford for me but also went to the hotel and picked up fifteen or twenty more messages of people who were in the same position as myself. He worked all Friday afternoon trying to get these messages out.

"He reached someone in Providence, who in turn

telephoned the message to my wife so that she received it about the time my train was due. I am writing this letter to let you know of what great value this amateur operator was to me and the others whose messages he got through."

The principal stations operating and the amount of flood traffic handled may be indicated approximately by listing figures compiled from replies received in answer to a letter to the 200 Army-Amateur Stations in New England supplemented by personal requests to other active amateur stations in the affected areas. The Radio Advisor realizes that this is not a complete report and that some unreported stations undoubtedly did creditable work. Comments on errors and additional information will be appreciated so that the final report may be as complete as possible.

Stations in the affected area, message totals, and stations worked are indicated as follows: 1AD (Bellows Falls), 125; 1fl 1aao 1azw 3ag; 1APL (Springfield Mass.), station flooded and inoperative; 1ARY (Burlington), t/c not reported, 1aaf 1eo 1zd 1apk 1caa 1in 1jc 1ta 1yb; 1ATU (Quechee), no report; 1BBJ (Montpelier), 257, 1acd 1ach 1apk 1atj 1azw 1jc BA7 1gp 1in 1lm; 1BEB (Montpelier), 229, 3hto 1ii 1amg 2kl 2pp 1epb 1va 1afz 3cab 8nr 1kf 1bdq 2uha 1jc 2kr 2uh 2fx 1bd 2anv 1fl 1avj 1zk 2sz 2hh 8vt 1axi 2afv 9avp 1bdx 3efz 2nj 1box 1azw 1big 2ih 3agw 8don 1in 1ak; 1BDX (Barre), no report; 1BJP (Newport), 117, 1fl 1cmc 1acr 1ky 1cop 1in 1ach 1afb 1beb 1ip 1jc 1ach; 1EZ (Pownal), no report, 1ach 1adw 1apk 1in 1lm 1mk; 1IT (North Troy), 68, 1tl 1af 1atj 1ta; 1YB (Hanover, N. H.), 63, 1ary 1aaf 1apf 1in 1ahv; 1YD (Norwich), no report, 1zk.

Stations and flood messages outside the flood area: 1AAE, 4; 1AAO, 27; 1ACH, 105; 1ADW (not reported tho 14 stations report working him); 1AFB, 20; 1AHV, 29; 1AKU, 41; 1AMU, 4; 1APK, 36; 1AQF, 7; 1ASI, 15; 1ATJ, 38; 1ATZ (not reported); 1AWW, 10; 1AXA, 56; 1AZW, 79; 1BAK, 5; 1BDI, 2; 1BFT, 10; 1BIG (no report); 1BQH, 6; 1CML, 1CNG (no reports); 1FL, 304; 1GA, 89; 1GP, 3; 1IN, 86; 1IP, 20; 1JC, 195; 1KF, 5; 1KY, 35; 1LM, 14; 1LT, 8; 1MK, 3; 1QY, 1; 1SK, 12; 1SL, 44; 1TA, 20; 1WL, 2; 1WQ, 8; 1ZD, 6; 1ZK, 100; 1XM, (unknown). In Washington, D. C., C. A. Briggs, 3CAB, handled large numbers of messages for the American Red Cross and the Army Signal Corps and maintained contact for long periods with amateurs in the flooded area. William Irwin, 2CUQ, and Ed Morhaus, 2CTM, handled a lot of Vermont-N. Y. messages and press direct by amateur radio. There are few reports from other men outside New England though several were heard taking traffic and relaying it south and west or delivering as necessary.

Much of the news eagerly awaited by the rest of the U.S. came from New England via the transmitters and receivers of amateurs. Stations handling press and the approx. number of words known to have been handled by each: 1AAO, 1500; 1ACH, 200; 1AHV, 1000; 1AXA, 1175; 1AZW, 300; 1BBJ, 77; 1BEB, 1500; 1XM, 77; 1GA, 1200; 1ZK, 2000. Three portable transmitters with battery power were taken (with an A. P. man) by automobile into flooded Vermont working on 45 and 85 meters. This M. I. T. Flood Radio expedition covered 500 miles experiencing many difficulties and thrilling experiences. Much press was handled and credit for this work belongs to H. A. Chinn, 1XM, Cambridge; J. K. Clapp, A. H. Broly, P. S. Wolcott, portable 1XM, Ludlow and Bethel Vt.; L. T. Goldsmith, portable 1XAN, Brattleboro, Vt.; G. G. Macintosh and S. L. Davis, 1XV-1RHS, So. Dartmouth, Mass.

Very material assistance was rendered by stations maintaining a constant intercept of traffic channels to stations in the affected area samples of which follow: 1ACH took a rush message from 1BBJ for New York after which 1BBJ's power was interrupted. During the interim a "2" got hold of 1ACH, said he had intercepted the message and would telephone delivery at once. 1BAK and 1AW intercepted messages and made immediate delivery. Other intercept stations were 1AFB, 1AKN, 1AQF, 1BBC, 1BWY, 1QY, 1FP, 1BJK, 1CNG before abandoning his own flooded station sent several broadcasts asking amateurs to help in the emergency. 1ADW helped 1EZ to locate 1BFT. 1BBC assisted 1BDI in locating 1BEB. 1WL sent two messages broadcast, receiving a reply to one next day. Many amateurs after getting a line on the hook-up of those stations working into the effected area rush to their assistance: 1ARV to 1ACH, 9CKS to 1SL, 1AFC to 1FL, 1GA to

1AHV, 1IN to 1APK, 1ES to 1AW. Message delivery was by messenger, telephone and telegraph many being relayed by radio—some being given to WBZ, WBZA and WEEI for broadcasting. Of 96 messages given Western Union to go forward collect but two were undelivered for lack of correct address. ISL between schedules raised several stations causing QRM on important channels and asked them to QSY. Many other stations not in communication with stations in the flooded districts assisted in this work of keeping stations not concerned with flood work off the channels used by 1BEB, 1BBJ, 1BDX etc. Stations approached in this connection showed readiness to cooperate and fine amateur spirit in promptly and gladly complying with the request to QSY.

In reporting the flood communication work from a U. S. N. R. standpoint Lt. Russell writes as follows.

"At the time of this crisis the master control station, NRRRA, was temporarily disabled, necessitating aid from two section commanders, Ensigns John M. Wells and Frederick Best, both of the Volunteer Reserve.

"About 2:30 on the afternoon of November 5th, Wells received a telegram from the District Communication officer requesting him to relay a Red Cross message to Montpelier. At that moment neither the transmitter or receiver at 1-ZD was in commission. By three o'clock, however, 1-ARY on the other end was pounding back the information that nothing had been heard from Montpelier, but that the message would be sent from a local broadcasting station. Another schedule was arranged for 5 p.m. When that hour came round, 1-ZD and 1-ARY were again in communication, and the latter station reported success in delivering the message by local telephone service, which had just been opened, then transmitted the answer for the DCO by long distance, receiving another message for Montpelier in return. 1-ARY successfully delivered this message also, reporting back on the 7 pm schedule.

"While all this was going on, 1-BIG, roared forth from Augusta, for Best had also been requested by the DCO to handle Red Cross traffic. Hearing 1-BEB in Montpelier with a strength 9 signal on the forty meter band, Best shifted his transmitter to approximately the same frequency, and started a long battle for an audience. In spite of the desperate efforts of 1-BIG, the Vermont station was completely tied up with traffic for New York, and kept working second district stations one after the other. After calling in vain throughout the entire afternoon, Best shifted to 75 meters, whereupon he heard 1-BBJ in Montpelier, who seemed to be having trouble in receiving. Finally, after much intermittent operating, 1-BBJ called 1-ACD in West Hartford, Conn., with a message for the Red Cross. Noticing that 1-ACD was having trouble getting the message through had interference. Best copied the message and relayed it through 1-UE, who in turn phoned it to the Boston Navy Yard. Almost before the message was received at 1-ACD, it was already on the Washington wire from Boston.

"1-BIG notified six different New England stations of the message for 1-BBJ, and at one time there were seven calling that station advising him of the rush message at 1-BIG. 1-ACH, whose reliable work is worthy of considerable mention, succeeded in holding up 1-BBJ long enough so that he (1-ACH) could relay the message successfully. That ended the eventful career of that message as far as we are concerned.

"Both 1-UE and 1-ACH did excellent work in co-operating with the Naval Reserve stations. Because of his proximity to Boston and also on account of his splendid record during the early part of the Vermont disaster, 1-ACH was assisted by Navy personnel at his station who kept the telephone hot with messages to be telegraphed by wire."

It is not likely that the next emergency will be in New England. Emergency service is one of the primary functions of the Army Amateur Radio System, however. In the Mississippi valley, in Florida, in San Diego, California amateurs have done remarkable and noteworthy work in emergencies. No one knows when the next emergency will turn up. It is therefore suggested that we look around today for a suitable source of emergency power supply and take note of the suggestions that have been sent to the Radio Advisor based on actual experience in the New England emergency, so that we may adopt those that are most practical and render even more

perfect and expeditious service in the next emergency that confronts us. The suggestions made re-emergency operating are as follows: (1) That a Corps Area amateur net control station and message center be established under the direction of the Corps Area Signal Officer. (2) That army controlled frequency channels and calls be authorized to stations working in the affected areas and stations keeping schedules with the same. (3) That all traffic be sent through the Corps Area amateur-net control station (message center). (4) That certain stations be assigned by the net control station to accept traffic for the stations in the affected areas and deliver same to the message center for transmission. (5) That stations not engaged in handling emergency traffic refrain from transmitting. (6) That stations near other stations in the affected area offer these stations their services and any equipment they may need. (7) That as far as practicable operation shall be in the 80-meter band. (8) That stations in the affected area send out news bulletins at intervals, to be copied by intercept stations for the Associated Press. (9) That Military, Fire, Police, Telephone, and Telegraph headquarters in different cities be advised as to one or more amateur stations in their city. (10) That auxiliary power supplies be made available or their availability ascertained in time of emergency. (11) That all stations not handling emergency traffic act as intercepts and where possible expedite delivery of messages. (12) That all stations should make certain even though engaged with emergency work that they do not create interference to other stations engaged in the same work.

"Officials of the Federal Radio Commission are enthusiastic over the work performed by the amateurs, through which it was possible quickly to judge the extent of the disaster and make arrangements for speedy relief," declared Admiral W.H.G. Bullard, Chairman. "The commission has watched with the keenest interest and pleasure the reports of the fine work of the amateurs, which was in keeping with what they did at the time of the Mississippi flood and at other times when emergencies have arisen.

"This work on the part of the amateurs justifies the attitude of the commission that their activities should be adequately provided for in the allocation of wave lengths. The future of radio depends upon the amateur."

Maj. Gen. Charles Saltzman, Chief Signal Officer of the U. S. Army speaking as a member of the American delegation to the International Radiotelegraph Conference recently said, "Members of the United States delegation, realizing what wonderful things the amateurs have achieved in developing radiotelegraphy, did everything they could for the amateurs. There never has been a disaster or other emergency that hasn't found the amateurs on the job with splendid service, often incurring great personal inconvenience and hardship with no thought of any reward."

Several hundred flood messages of various kinds were handled by 1FL during the recent New England emergency. Since the flood has receded, 31 railroad messages have been taken care of. At the time of this writing (Nov. 26), the wires are still out between Newport, Vt., and St. Johnsbury, so that all traffic from Montreal to Boston has to be routed over the RR wires through Maine, or else come by amateur radio from IRJP in Newport. Vy FB work!

3CA, the SCM of Virginia, has a suggestion for clearing the hook. He says, "Arrange the station to work both the 40 and 80 bands. Then when you can't get the traffic off to short distance stations on 40 meters, don't send it to some distant station, but jump up to 80 and ham around a bit. No doubt you will hear a station that will be able to work directly with you and near enough to handle the traffic efficiently. 80 meters, although practically dead in the daytime, is perfectly good for dx up to and including 1000 miles at night, and is a good place to work. A load of traffic can be handled on that band without the usual QRM that you get on 40 meters."

An old Official Postal Guide, which can often be procured from your local postmaster for the asking, is a mighty handy thing for the shack, says 8BJE. These Guides contain complete lists of all the cities and towns in the United States, together with the county in which each is located.

Danger! Take Heed!

ONCE again it becomes evident that some of us are riding for trouble. The unfortunate thing about it is that certain individuals are not only in for trouble personally. They may bring the whole amateur fraternity in for a share of the unpleasantness and disrepute which are the consequences harvested when someone sows a crop of trouble. While the circuit breakers haven't actually tripped out yet, the symptoms of high heat and meters off-scale indicate sure trouble ahead unless some of us do some much needed tuning and readjusting of transmitters promptly on receipt of this issue of *QST*.

No doubt, dear reader, you have a most excellent reputation in your local community based on character and everyday performance. How would you



HIS LICENSE REVOKED!

feel if someone very close to you ran amuck and through pilfering and violence brought your name into disrepute? That's the way all good A.R.R.L. members must feel about the few rough-shod amateurs who persistently operate off-wave or adopt a defiant careless attitude concerning any B.C.L. QRM they may cause.

Let's change the scene and consider further. What if you either intentionally or unintentionally broke some law which brought disgrace and undeserved punishment to your family and friends as well as yourself? It is not nice to contemplate your feelings under these circumstances is it? The worst of it is that you and I may actually be in a position similar to this one and not know about it.

Trouble is brewing on two counts. Here are the facts in brief. (1) Complaints against more than thirty different U. S. amateur stations guilty of causing severe interference and interruptions in handling Naval traffic have been filed with the A.R.R.L. by the Director of Naval Communications in just a few weeks. Literally hundreds of our stations have been observed off-wave in the government point-to-point Public Toll Service band, 8000 to 9050 kc. (37.48 to 31.56 meters) (2) The Federal Radio Commission refer to the B.C.L. complaints of amateur radio station interference as numbering away up in the hundreds. Literally dozens of complaints roll in to the Commission daily right at a time when the Commission is trying to do its utmost for the listening public in improving the conditions for clear broadcast reception. The view that if the transmitting circuit complies with the general tenor of the license it is the listener's hard luck is coming to be shared but feebly by the Commission! Kicks of amateur QRM are increasing at a terrifying rate. The situation is again very serious. We are in danger unless we can show immediate improvement.

It all means that it's time to take account of ourselves, time to heed the handwriting on the wall, time to cooperate by becoming a trouble-shooter for our own stations and others we can find out about. Public opinion is a powerful friend and also an equally powerful enemy. The prestige and goodwill gained for the amateur when he renders invaluable and spectacular help in emergencies may be slowly undermined by the constant little irritations of daily code-interference. Unless both situations we have pointed out can be cleared up at once it is almost certain that a drastic policy of license suspensions and cancellations must be invoked against offenders. Attention may be called to the fact that

the Radio Act of 1927 provides still heavier penalties for malicious interference. Quiet hours may be invoked "whenever interference exists." From all accounts it would not be surprising to see the Federal Radio Commission change the present regulations to read "six P. M. until midnight" instead of "8.00 PM until 10.30 PM" as at present. Ignorance of a condition is not taken into account by courts of law. There is no excuse for law-breaking that gets by. Neither is there the break-down in regulation that caused so much comment a year ago—The Federal Radio Commission is the supreme authority in this country—an unquestioned authority empowered to set up suitable regulations and see that they are enforced "as public convenience, interest, or necessity requires." The picture of what threatens is not at all pleasant to look at you will agree.

In an indirect fashion we have been conscious of a situation that was becoming increasingly difficult at this desk. Some amateurs have written for help in clearing up key clicks. More frequently the wail comes from the amateur just after the Radio Supervisor has shut down his station or made it observe quiet hours. The OM now wants to know what he can do to fix his set so the trouble will be eliminated and so he can get the restriction removed. We had no idea that things were so bad until several departments in Washington told us the same story. Two local cases, one involving key-clicks and the other some non-selective B.C.L. tuners in a congested locality were also called to our attention by the local Broadcast Listeners' Association and that brought the situation home to us with a vengeance.

Perhaps some of the blame for the trouble may be given the set manufacturers. Many of even the better class broadcast (voice) receiving sets have an antenna connection directly to the grid or grid coil of the first r. f. tube or in some cases the detector tube. While it could just as well have a loosely coupled magnetic pick-up from the antenna the quantity production saving of a few cents dictates that a close coupled auto-transformer arrangement shall be used despite the fact that such an arrangement is much more sensitive to power leaks, static, key thumps etc. Super-hets with high plate voltage on the oscillator get into trouble readily when the oscillator harmonics beat with our short wave signals. Too-long antennas make other good receivers non-selective. The situation is one that must be faced just as it stands, however. Fixing the blame does very little good. There are two sides to almost every argument. Sometimes key clicks from the amateur station are at fault and ruin reception for a whole community. In other cases proximity to a power line which supplies a ham transmitter together with a whole raft of B.C.L.'s causes high frequency energy to practically blanket reception in a given neighborhood through induction or conduction to the several installations.

The worst of it is that the last person Mr. Average B.C.L. wants to complain to is you and I. Human nature doesn't work that way. Friend B.C.L. may call on the local radio store from which he purchases his set, he may call on the local newspaper, magazines, radio service men, broadcasting stations, light and power companies, telephone companies, the police department, municipal officials and so on down the list. He seeks to locate the authority to "have this stopped." He wants to know what rights he has and what rights the amateur station owner has but first of all he wants the trouble stopped regardless of whether he owns a blooming single circuit, a hunk of galena, or a really good neutrodyne of the common five-tube variety. If familiar with radio matters, friend B.C.L. may write A.R.R.L. Headquarters or the proper Department of Commerce official (Radio Division). We get many such letters. More likely some letters may reach members of the U. S. Senate. It is most probable of all that he will write the Federal Radio Commission, known to him through numerous press releases. The Commission's most important function (or so the public thinks) is to improve conditions in broadcast reception. The pressure of public opinion brought to bear on the Commission is bound to re-

sult in special attention being given this subject. If amateurs continue to cause interference complaints to reach the Commission (which prove in most cases investigated to be authenticated code-interference cases) we have not the slightest doubt as to the final outcome. Regulations that clamp on the lid will be impartially issued to govern those who have the temerity to interfere.

Our first duty to ourselves is to stop these complaints to the Federal Radio Commission from individual broadcast listeners—to keep well within the amateur bands so that interference with Naval traffic handling stations cannot occur and so that an official complaint by the Navy Department to the Federal Radio Commission will not be necessary. Carelessness on the part of many, and wilful law-breaking on the part of a few men must not be allowed to jeopardize the enjoyment of all amateurs. Individually we must accept responsibility in clearing up not only interference caused by our own stations but also in helping other amateurs to do the same with their local interference—notifying all off-wave stations heard and asking them to get into the nearest amateur band, bringing pressure to bear on backward stations through organization. As an organization we must tackle these problems by sending notifications of off-wave operation out from the Official Observers in greater numbers. Section Managers should appoint an additional number of competent Official Observers in each Section. Affiliated clubs can help a great deal by local policing of the air to improve the off-wave situation. Club interference committees containing representative members from the ranks of amateurs, B.C.L.s and the local press can work to good advantage in taking care of code-interference in congested localities, recommending the proper authority in any cases that turn out to be something besides code interference. Such committees will prevent complaints from going out of the local community by applying a remedy right at the source. We earnestly request those of you in positions of responsibility to get this machinery to functioning in your clubs and in your Section A.R.R.L. organization.

Making friends with our neighboring B. C. L.'s is a necessary and desirable first step in taking action individually. Don't wait until complaints are being traced to you. Make a canvass of your immediate neighborhood and inquire regarding receiving conditions. Often as not you can give Mr. B.C.L. some dope on his outfit that is news to him and make a friend whether any code-interference is troubling him or not. Cooperation pays big dividends sometimes. It is most convenient to really know the man next door. He can often help you in checking for key-clicks or QRM when a new transmitter is built or something is changed in the present layout.

Suppose trouble exists. If a key click bothers, a 1½ to 3-henry choke between the key and the set (key assumed to be in neg. H.V. or in center tap) with a couple of mikes across the key usually takes the corners off the steep wave-front by applying the voltage gradually thru the cushioning inductance. If the condenser makes the key spark use 100 to 500 ohms resistance in series with it (or a variable resistance) adjusting to the optimum values of C. R. and L. Pages 136 to 139 of the Revised "Radio Amateur's Handbook" contain plenty of further information on thump elimination. September and November, 1927, QST also offer good suggestions on this business of curing key thumps. The writer has had excellent results with the simple thump filter described above. If troubled with r.f. energy in addition to or instead of a key click it becomes our duty to build and place wavetraps in the antenna or ground leads to B.C.L. sets. Such traps are simply condenser-coil combinations inserted in the lead between set and antenna or ground of suitable dimensions to tune to the wavelength of the amateur station. Putting r.f. chokes in the power line leads at the transmitter in B-eliminators, moving antennas to right-angle positions, loosening coupling to the antenna, and cleaning up noisy plate supplies may also prove necessary. Inexpensive wavetraps have proved the most helpful solution of many interference cases. They have saved labor in re-constructing non-selective coupling arrangements in B.C.L. sets, aside from the fact that most B.C.L.'s object to having any changes made in the receiving tuner. Full instructions on wave-trap construction and installation will be mailed gladly to anyone who cares to write for it and specify what wavelengths must be covered. Quite surprising results have been obtained with the use of a properly built wave-trap even with adjacent sets,

parallel antennas, single-circuit tuners etc. Remember—a key thump filter arrangement (or a slight change in the keying circuit as it now is) plus a wavetraps for such B.C.L. sets as need them will do the necessary in almost every case unless there are special conditions, obsolete oscillating receivers and so on. Get your dope today if you need it!

Now to get back to this off-wave business again. There is not the slightest excuse for anyone being caught out of the band. Besides the standard frequency transmissions there are plenty of good wavemeters available. If you haven't any you can easily borrow one or build it from Handbook specifications. Make some coils to cover just the amateur bands on the useful part of the dial for greatest accuracy. Check any wavemeter you may have as frequently as possible for accuracy using the standard frequency transmissions—it is liable to get knocked out of adjustment like any other measuring instrument.

If you just think your wave is O. K. *make sure*. Be sure if you operate in our 7000-8000kc band that you are well on the right side of NAA and *within* the band. Use the fact that NAA is crystal-controlled and works on exactly 8030 kc. (37.4 meters) for your guidance.

When any of us operate below the band we are in danger of impairing the efficiency of Naval communications channels. Put yourself in the position of a crystal-controlled station obliged to operate on a fixed frequency with thousands of words of important traffic to be moved—obliged to stand-by while some unworthy ham sends a long drawout CQ DX. There are no Naval stations working in our bands. The Navy Department has been very friendly to us and as you will read elsewhere in this issue, very helpful in securing adequate privileges from the International Radiotelegraph Conference. The friendship that has been so valuable and helpful surely must not be trampled upon by any inconsiderate amateur. The Navy stations are entirely justified in objecting to any amateur operation in their bands. As we have said before, the A.R.R.L. is going to act for the good of the majority and take suitable measures to bring recalcitrants into line if it becomes necessary. If each and every one will cooperate as has been suggested it will not be necessary to consider further steps for self-government and protection of our privileges. The folks who have been abusing their privileges are headed for certain trouble at no distant date. Prompt action is required on all these matters. It's up to each and every one of us to get busy collectively and individually—for after all it's a personal problem. Every reader is asked to consider that he is being addressed personally and to put his shoulder to the wheel in making a general check-up of conditions. After everything is absolutely 100% O.K. at your station see if you can't help someone else. It's up to us to accept the facts as we find them and put our house in order at once without any grumbling. If Headquarters can help you in any way just drop us a line giving complete information on the nature of the difficulty.

—F. E. Handy.

OFFICIAL BROADCASTING STATIONS Changes & Additions (Local Standard Time)

1BZ (37.6): 4CK (40) 7 pm. Mon. Fri.: 8CNC (40) daily except Sun. 7 pm., 2 pm Sat.; 9BWN (38.2) Wed., 10:30 pm. (76.4) Wed. 10:45 pm.; 9DNG (38.3) Mon. Wed. Fri., 10 pm. Sun. 6 pm., Sat. 6 am.; 9DUZ (85) 7 pm. Tues. Fri., (42.5) 12:30 pm. Tues. Fri., 9ZD (40.8) 7:15 pm. Tues.

ARMY AMATEUR NOTES

SECOND CORPS AREA—In order to test the proficiency of the A-A operators in this area, a contest, open to all active A-A stations in the area will be held during January, 1928. The contest will consist of a series of transmissions from 2SC, the Corps Area C.S., on 77.8 meters. Three messages will be sent on three separate nights, and will be repeated at stated times during each night in order to give all participants an equal opportunity to copy them. The test messages will be both in code and clear. One of the code messages will require an answer which shall be sent to the C.S. of the Net, to which the A-A station is assigned. Credit will be based on a point system, and the operator with the greatest nr. of points will have first choice of the ten prizes it is hoped will be offered. It is proposed to give 25% of the total points as credit to

the amateur writing the best essay on a subject to be announced in the test msgs. Credit will also be given for keeping the weekly Net schedules.

2CP, the new N.C.S. of the N.J. auxiliary net has stirred things up, and most of his stations are keeping schedules. 2AOP and 2AAT are the most active. 2ALS, 3HW, 2AFV, 2APD, 2ARM, and 2PF are also active in the various Nets. 2EV would like to obtain more active stations for the Manhattan Net.

FIFTH CORPS AREA—The old Net was re-organized, and a trial made on Nov. 18, but apparently without much success. 8GZ, the NCS, was not on the air at the time. It is hoped that activities will go forward with a bang with the coming of better radio wx and more tests. All interested in the work should get in touch with Capt. Glessner, Signal Officer, 5th Corps Area, Fort Hayes, Columbus, Ohio, or with 8MYN. QSO with the NCS, 8GZ, will also help matters.

EIGHTH CORPS AREA—The NCS, 5AIN, was on the air regularly during the month, and its signals appear to be getting out very well, since call cards were received from many distant points.

20-METERS

5AVS (Fort Worth, Texas). "5WZ and 5AVS are now on 20 and 40 with an 852. Our best QSO on 20 is with fQOCDL, Duata Radio Station, French Cameroons, West Africa. We keep a schedule with him Thursdays and Saturdays at 6.15 pm CST. He is on 20-meters flat with a 500-cycle note. It takes 1½ minutes for him to get his gasoline-driven generator started after one sign-off. This has caused some amateurs to lose a QSO with him as they become impatient and don't listen that long. fQOCDL is the only African heard here on 20 and he is often R7!"

6EA (Los Angeles, Calif.) (rec'd via 1ABA on 20-meters), "Have had two-way communication on 20-meters with eg6YV, oz2AC, oz2XA, xnuWNP, na7KN, oh6BDL, oh6CLJ, nc1CO, nc2CG, nc3CS, nc4FA, nc4IO."

8AYU (Glen Falls, N. Y.), "Have worked 2nd, 4th, 5th, 8th and 9th districts as well as the first Canadian district but have been unable to QSO the 6th and 7th on 20 though I have heard and called them. I only use 20 in the daytime but have worked ef8CT, eg6BY and eh4CB with good reports. I find it easier to QSY to 20 and get a decently steady sig. than to do the same on 40. With my 210's I could go down to 15 or even 10 meters just as easily. I don't have any trouble with parasitic oscillations with the two 210's in parallel since I shortened the leads so the grid leak and condenser and the plate blocking condenser hook direct to the tube socket connections. The center tap lead is only 4" long and the tuning condenser leads in proportion. For 20-meter work one certainly cannot have his r.f. leads all over the shack. I can duplicate my 20-meter daylight work with the same input (44 watts) on 80-meters before and after quiet hours at night, working 6's and 7's in addition though no foreigners. Re Mr. Redfern's report in last QST—was QSO 2BYW Oct. 30 from 7.11 to 7.30 pm. His sigs were R8 with a decided ripple, nearly all the dots missing."

9EF (Hammond, Ind.), "Of late 20-meters is dead after 7pm CST. South American signals are getting weaker while European signals are increasing in intensity. I wish more European stations would attempt 20-meter QSO with the U. S. A. around 1200 or 1300 GCT (our early morning). I should be glad to schedule any eg station for early morning 20-m reliability tests. eg5ML is to be complimented on the wonderful consistency of signals. Can work him from 6am until dark. foA3Z is great from 1600 to 2130 GCT when he retires usually."

1SZ (Hartford, Conn.), "Am now using UX-222 with result that foreigners actually rattle the cans. Have heard no more DX with the addition but much easier to copy what I do hear. Schedules at various times of the month were kept with eg3HS, eg5ML, x6DU, WNP, foA3Z, su2AK and old reliable 9EFH. Still keeping an eye out for ai2KT and af1B on Sundays around 1300 GCT with no results as yet. ai2KT has heard several "nu" stations on 20 from 1200 until 1330 Sundays. Signals do not QSS now as compared with summertime work on 20 but the hours have dropped until signals cannot be heard after 8pm EST. South American stations are slipping off altogether, though Europe and Africa still come thru well. foA3Z recently made first fo-oa contact on 20. The "oa" and "oz" hams do not bother me a bit any more. Have given up listening every minute of the night for them. They just do not break thru to my station. When first QSO x6DU he was rounding Cape Horn but at last QSO he was safely in Buenos Aires after rough weather of it in which amateur radio on 20 meters was the only method of communication."

Call	Orig.	Del.	Rel.	Total
8BAU	47	51	902	1010
6ALH	422	307	101	930
3CBT	122	101	466	789
1FL	47	177	512	676
op1HR	139	121	244	504
8EU	38	50	382	470
8CYK	174	12	231	417
8DBM	35	334	35	404
6BJX	110	263	22	395
8AVK	42	19	316	377
1BBJ	201	158	12	371
98KV	48	33	252	333
1YD	278	36	4	318
1ACH	86	92	139	317
1BEB	189	60	58	307
1IP	30	39	214	283
8GI	2	19	256	277
7ST	101	97	74	272
1MK	102	82	82	266
9LV	14	54	194	262
9DXZ	14	67	180	261
8BVV	100	151	—	251
9BWN	8	3	240	251
9DLL	34	32	158	223
9DTK	63	23	134	221
2AFV	15	23	179	217
2CP	51	41	120	212
9CZC	3	13	194	210
8AMU	35	22	148	205
3AWT	32	38	134	204
9EAM	7	35	158	200
1KY	32	64	79	175
7ABB	79	91	4	174
6AMM	60	76	12	148
1UE	6	90	37	133

8BAU takes the honor position this month by consistent relaying work—more power to him. From 21st place to 1st in one month is some accomplishment. The whole list comprises the very cream of our traffic handlers, stations famous for emergency work, for consistent schedule keeping. 1KY, 7ABB, 6AMM, and 1UE "make" the B. P. L. for some very worthwhile performance in making message DELIVERIES.

A total of 200 messages—or just 50 deliveries will elect you to membership in the B.P.L., OM. Why not keep some regular schedules and organize some traffic routes, or solicit good messages locally and through the stations you work to put you on this honor roll?

Two stations have been licensed in the Virgin Islands. These are np 4AAN and np 4ACF. Of these, 4ACF, who sends us this information, is the only active one at present.

Our apologies for omitting some of our usual C. D. subjects this month. The report on the International Radiotelegraph Conference together with the story of amateur work in the New England Flood made unusual demands on our space. The list of R.M.'s, an announcement about Commander Dyott's Expedition (GMD), our page of Section Managers, an article explaining how to get up a "real" hamfest, a report on the Burgess Plane Tests, and a bunch of Traffic Briefs must be held until next month. A story of WNP work is coming that will be worth waiting for and items concerning VOQ and KFLP also may be looked forward to with interest.

DIVISIONAL REPORTS

WESTERN NEW YORK—SCM, C. S. Taylor, 8PJ—Western N. Y. put itself on the radio map this month by the efforts of several amateurs who handled messages during the Vermont floods. 8UL got about the first news and notified the Red Cross in Boston through 1YB and Western Union. Many other amateurs handled press reports when all other communications failed. The W.N.Y. bunch has handled more messages of value than ever before and schedules are on the increase. Mr. Crossley of 8XE desires to know just what dates will be convenient for all members who can attend the next A.R.R.L. Atlantic Div. Convention next June. Please write him, gang.

8ADE is working hard on schedules and handling traffic. 8AFG is coming back on the air again and will be hot after schedules. 8AHC worked 4NP and ne-8WG at Labrador. 8AIL can get traffic thru to England any time. 8AKC worked WNP, ef, and en. 8ADG works 2's in daylight on 20, also Australia and New Zealand. 8ANK is off the air due to heavy work. 8AWU is a new arrival this month who handled traffic. 8AYU handled flood traffic from Vermont and has schedules with 1MK. 8BCM has many skeds. Traffic is slight due to school and YLs. 8BFG works on 20, 40 and 80. 8BQK handled traffic. 8BLP is away at school. 8BMJ worked all districts and says he's got a couple of recruits lined up for traffic. 8BUJ is rebuilding the station. 8BZP is off due to a broken arm so he can't pound brass. Sorry to hear it, OM. 8CAJ wants an ORS, and he's a good brass pounder. 8CNT handled New England flood traffic. 8DML also handled traffic. 8CNH is changing to 20 meters. 8CYK handled heavy traffic with lots of schedules. 8CVJ worked 6YQ, 5MG and 4FT with 23 watts input. 8CDB handled traffic during the flood with his new transmitter. 8CPC did work for individuals delayed by the flood. 8DDL handled flood reports galore for Rochester newspapers. The Rochester Radio Club is humming again with a new President, 8KT, who is hot after the hams.—8DME worked Iowa. New Orleans handling traffic. 8FU is after schedules. He has worked nc4CK.

Traffic: 8ADE 46, 8AHC 93, 8AKC 46, 8ADG 6, 8AWU 6, 8AYU 91, 8BCM 18, 8BFG 10, 8BQK 5, 8BMJ 40, 8BUJ 2, 8CAJ 8, 8CNT 30, 8CYK 417, 8CVJ 11, 8CDB 137, 8CPC 25, 8DDL 56, 8DME 10, 8KS 8, 8PI 4, 8PJ 7, 8QB 2, 8SB 41, 8TH 11, 8UL 10.

MD-DEL-D. of C.—3ABM is off temporarily due to a fire burning up his entire outfit. He will be on in a couple of months with 2 50 watters in a self-rect. circuit. 3RRW and 3BCX have applied for an ORS and seem to be ready to do some good work. 3CFX is hampered by not having a sked south. (Get in touch with your RM, OM). 3ASO operates day and night and says if 40 meters is taken away, he will QRT. 3PU is back on 40 and 80 meters. 3CE got his commercial license and is very proud now. He says he is not going to sea right away, tho. 3CGC was only on to keep his sked with 3QY. 3BWT is on whenever possible but no regular skeds are kept. 3AED and 3ALQ are active and rarin' to go.

Traffic: 3CFX 37, 3ASO 12, 3PU 4, 3CE 3, 3CGC 38, 3BWT 3.

EASTERN PENNSYLVANIA—SCM, H. M. Wallace, 8BQ—Our new RM, 3QP is well under way in Phila., and turned in an excellent report. You Philly stations stay with Morgan and you will stay on top. 8EU, our mighty Wmsport RM, leads the tlc pushers again. A new one turned up in Scranton—8BBS. FB, OM. 3QM will get on 80 if he can clean up the QRM to BCL up there. 3NJ has been DXing up cash for a new bug. Hil 3RMS can't hear Asia! And 3HD thinks I am on 4011 wat next? Every "three" on 40 expects to be the first "3" to WAC. 3HH is one of the many. Hil 8WJ keeps tlc moving nicely. The ole Xtal is blasting out for 3SM. 8BQ'S YL QRM'S the works yet. 3CDS is on the job with early morning skeds. 3AWT knocked out BPL honors. 3BQP doesn't have much time but heaves a mean DX sig out. Late hours are kept by 8BIR. Receiving conditions were punk for 8AV. The QRH flops for 3QY so an xtal is in order. The new RPL limit let 8ADE out he did nice work 8EU has a full fledged power house behind his sigs. Hil Low power and 20m, are busting out for 8AKW. 3QP is busy on 80 but drops to

40 now and then. 3NF works skeds on 80 now. 3ZM promised me a bbl of cider for Xmas. FB, include sum tlc, OM. 3NP still handles a few. It's tough that the rest of the reports were LATE. Therefore, they cannot be included. Let it be a lesson. The 26th is THE DATE.

Traffic: 8EU 470, 8AVK 377, 3AWT 204, 8AKB 102, 8ADE 141, 8QY 126, 3SM 116, 8CGZ 86, 8BQ 84, 3QP 64, 3NF 50, 8WJ 49, 8AFA 46, 3AKW 36, 3NJ 36, 3HD 31, 3BMS 28, 8BBS 27, 3BQP 16, 8BIR 15, 3BFL 14, 3LC 13, 3VF 8, 3CDS 8, 8AVL 8, 3NP 7, 3ZM 4, 3QM 3, 3HH 10.

WESTERN PENNNA—SCM, G. L. Crossley, 8XE—After the letter was sent to all the ORS in this section during the month, the SCM actually expected that all the ORS would send in their report this month. There were 7 stations that did not report. 8CEO auctioned off his sine and now has a UX281 with rectifiers. 8AMU handled traffic but no time for DX. 8AKI has helped organize a radio club at Altoona. 8CRK likes the lower 80 band for working. 8BGW is QRW. 8ABW blew his 50 watter experimenting but is on now with 15 watts. 8AGQ is in operation but at the time are training operators. 8GK has a 20 meter Hertz but ND on 40 so he says. 8BRM is on regularly for traffic. 8CES wants schedules. Ask the RM, OM. 8DFY is using fone now and is helping to train new ops. 8GI had some BCL trouble but they found it was some OSAs and power leak. 8VE is inactive because of school. 8ZD is on 20 and 40 with 250 watts xtal. 8CFR says a BCL cut down his antenna but it is up and running again. 8XE expects to remodel the sets both transmitters and receivers during Xmas vacation. 8DOQ's serial came down. He is using a 208A now. RM Anderson is doing his job fine and will try to arrange schedules for anyone wanting them. Get QSO him and see how good he can do it. 8BRM has moved again but is back now.

Traffic: 8GI 277, 8AMU 205, 8CEO 187, 8AKI 65, 8DFY 46, 8DKS 21, 8CFR 14, 8BGW 11, 8CRK 10, 8BRM 10, 8DIP 9, 8GK 9, 8VE 8, 8AGQ 7, 8ARC 2, 8DOQ 54, 8XE 184.

CENTRAL DIVISION

INDIANA—SCM, D. J. Angus, 9CYQ—Much better reports this month helps the standing of Indiana and pleases your SCM. 3CSX moved from Akron, Ohio to Rockville, Ind., and is going again. 9ADJ is on with 2-112s and a B-eliminator on 40. 9EGE is getting plenty of traffic on 40. 9RZZ says that he hopes Santa doesn't run out of 852s. 9CNC is experimenting on 20 with some success. 9BUQ has moved from Anderson to Indianapolis, Ind. 9BKJ is putting in 216B rectifier tubes as 9BBJ wanted his "S" tubes back before they blew. 9BYI is on both 41 and 79 meters. 9RCM has a new set of Cardwell condensers and a 40-meter Heriz and says it did wonders to his signals. 9DDZ is going after a commercial ticket. 9AGZ is back on the air on 40. 9DBA has a crystal ordered and will have it going soon. 9CIZ is going strong on 40. 9AXO is coming on with a new 50-watt station, completely rebuilt. 9AMZ is getting good results with voice on 20 meters. 9AVB is coming on with a new station and trying for an ORS. 9BIA is changing to 150 meters for fone. 9AAI just had his MG repaired and is on again. 9AAI and 9BKJ are conducting the code school for the Fort Wayne Radio Club. 9DSC and 9CRV are experimenting with master oscillator control. 9DUK has a beautiful new panel outfit. 9CRB is a new ham in Munice on 40 meters. 9DBJ is on 20 meters.

Traffic: 9AIN 113, 9EGE 52, 9BQH 14, 9DDZ 3, 9BCM 30, 9BYI 4, 9BKJ 6, 9CNC 25, 9RZZ 17, 9ASK 26, 9EAA 15, 9DBJ 17, 9EJU 13, 9EKW 20, 9RS 5, 9DSC 28, 9CRV 2, 9AXH 2, 9CBT 1, 9CLO 5, 9CYQ 84, 9AXO 11, 9DBA 30.

MICHIGAN—SCM, Dallas Wise, 8CEP—9CSI is the new RM for the U. P. Get in touch with him for schedules. 8NP is on regularly now and is looking for traffic. 8DED was rebuilding but turned in a fine total anyway. He is still Michigan's star traffic man. 8KN, Lansing High School, wants schedules with other schools. 8CHT please note. 8ASO works Miami College, Oxford, Ohio. 8CYM reports had luck, antenna blown down and blown blocking condensers. 8BRS handled quite a bit of traffic for the Philippines. 8AMS is lining up a Philippine route

also. Capt. Baldwin 8DKK handled a 264 word message from WNP via 1FL and now has set perking on 20, 20 and 80 meters crystal controlled. 9CE is on regularly now and has daily schedule with 9AYR. 9ACU operates now and then. 9CM is QSO both coasts on his crystal controlled outfit on 40.3 meters. 8MP and 8SY are too busy with BCLs for any Ham work. 8SY is now Radio trouble shooter for Det. Edison Co. 8DNJ of Bay City reports loads of DX but no traffic. 8DIV is having trouble finding an early bird for a morning schedule. 8AUB blew his big transformer and now is on with low power. The Grand Rapids gang are hard at work on the 1928 Michigan State Convention which will be held during April. Save the pennies, fellows, they are going to put on a real time. 8ZZ's 80-foot steel mast developed fallen arches during the last big blow so now ZZ is going to put up a new low loss mast. The Southern Mich. gang will all be present at the Monroe Hamfest January 22nd. Big feed and some real dope on "Hertz" antennas are the program so far. 8CWX is still rebuilding. 8ZF says the school message is keeping them busy.

Traffic: 8ZF 34; 8AAF 8; 8NQ 8; 8KN 8; 8ASO 11; 8CYM 2; 8BRS 12; 8AMS 5; 8DKX 35; 9CE 18; 8ACU 4; 9CM 3; 8ZZ 36; 8CEP 8; 8DED 97; 8AUB 6; 9CSI 15.

OHIO—SCM. H. C. Storck, 8BYN—Well, Gang, it seems you are going to allow 8DBM to cop the traffic prize without a struggle. He leads OHIO again with 404, which sure is great business, but gosh—look at this boy 8HAU—WOW! He kicks in with more messages per month than have been reported since the old rubber stamp days—1010. 9DBM may fall down next month—but if he doesn't—he gets the 352 as per his boast, for he has led two months in succession now, tho there has been no report yet from the RM. 8CFL, a wonderful traffic station, comes third this month with 113, followed by the SCM with 112. 8CQU comes thru with a few but had tough luck as the filament of his 204-A had its filament broken in shipment. 8ALU, 8BAS and 8AVX handled some. 8DDK, a non-ORS handled 34. 8ALU wants all the ORS to come thru with information asked for. 8BAS is on 80 mx and looking for all the traffic he can get. 8AVX now has good location for set and hopes to get out. 8CNO, the OW op. is progressing nicely, but is rather discouraged. Buck up, CNO, the best is yet to come—you have the YL field to yourself—don't get discouraged as ORS. 8CMB is trying 20 again. 8OQ says more traffic work now that football is over. Hi! 8JB has a new short wave receiver. 8AVB got all his traffic on 20 and says it is getting better right along down there. 8APZ is putting in a M. O. circuit. 8CQ will have DC plate supply soon. 8AYO is getting traffic on 20. 8BNW reported a radio. What faith some people have! 8DHS and others are "sore" about the Conference. It's OK now, isn't it, OR? 8AEU is putting in Xtal control. 8DPF is in training for basket-ball and Can't stay up late. Hi! 8GL says he is the "Hard luck king of the world" but 8DJV runs a close race, still he says he is going to get the 852 from under 8DBM's nose yet. FBI! 8DSY has been trying fone on 150 mx. SPL has another crystal—Gee! 8GL is still without a plate transformer altho has rebuilt his rectifier, and is living in hopes. 8DQZ is QRW school. 8CZ is back, with a mercury arc. 8DMX is still on 20 and trying fone. 8DIA has been QRW, but will be on 80 mx soon. 8CLE is QRW school also. 8BEV is back with the OHIO gang again. Welcome, OM. 8BKM has been vacationing and visited the Montreal hams. 8BOP is on 20 and wants schedules. 8ARW has been "chief of staff" in building a new home and couldn't hammar brass after hours. 8AWX has been very QRW, but QSO'd the Burgess airplane. 8EQ is using a "Zepp" antenna now. The SCM has been on 40 and 80 and has enjoyed quite a few QSOs with the OHIO gang. RM, 8ALU is doing his best to get things going—working hard. Give him a lift, OMs, and let's get more schedules going. If you make your own, report to 8ALU for his information. Don't forget to turn in your totals to 8ALU if you are in the contest. Let's hear a little more standard practice on the air, gang, and don't put in so many superfluous signals. Another abomination is not keeping schedule. If you make one—keep it to the minute. Is 8DBM going to get the Grand Prize? Next month will tell. Let's Go!

Traffic: 8RAU 1010; 8DBM 404; 8CFL 113; 8BYN 112; 8DHF 78; 8CQU 64; 8ALU 38; 8AVX 37; 8AVX 36; 8CNO 35; 8DDK 34; 8CXW 26; 8CMB 24; 8OQ

23; 8JB 20; 8AVB 16; 8APZ 14; 8CQ 14; 8AYO 12; 8BNW 9; 8DHS 9; 8AEU 8; 8DPF 7; 8DJV 6; 8DSY 5; 8PL 4; 8GL 4; 8DQZ 2; 8GZ 1.

KENTUCKY—SCM. D. A. Downard—9ARU—9BWJ is working up in the mountains but manages to get home every week end to pound brass for a few hours. 9CRD, 9CIS and 9CJW each worked eg5YQ on 20 meters. 9CJW forgot to throw his antenna switch but worked WNP and got R-4 on his sigs. F. B., OM, 9BAN is making an old timer out of a little fellow in Henderson that has been confined to his bed paralyzed for five years. 9BAZ is STILL having trouble with his mercury arc rectifier. 9WR-9OX are getting out FB with their 852 tube. They report code via the other to a couple of beginners. 9KZ had the good luck (?) to burn out his generator. 9ARU is on the air on 20, 40 and 80 meters.

Traffic: 9WR 140; 9CRD 47; 9BAN 40; 9BAZ 29; 9DWQ 11; 9MN 10; 9BWJ 2; 9KZ 1.

ILLINOIS—SCM. W. E. Schweitzer, 9AAW—The SCM is happy to see the way reports are still increasing and the interest the gang are taking in the section's traffic report contest as mentioned in last month's Illinois report. It has been suggested that inasmuch as some sections have more stations than others, it would only be fair to these sections to revise the reporting rules to be in proportion. Let us work the contest out in this way, each section receive from the supervisor of radio a list of the number of stations in its section, then take the number of stations reporting, and the winner of the contest should be the section having the most stations report in proportion to the number of stations in its district. This will afford an equal opportunity for each section to see which section has the most active supporters in the league. 9AAW has been operating with AC supply. The 500 cycle and DC supplies are being repaired. 9ACU has been experimenting on 20 meters this month. 9AFA worked WNP consistently. 9AFF reports that Army work will be starting soon. 9AGG reports traffic picking up and expects 9CXA to operate on schedule with 9CAD. 9ALK is keeping schedules with 9BII Tuesdays and Thursdays. 9AFY handled 5 flood messages from 1BEB. As Route Manager, he wants the gang to report their schedules to him so he can organize the section in the national hook-up. 9AWX has eleven schedules and is operating regularly, even after a heavy Thanksgiving dinner. 9AYB is operating 9CAR with a bunch of college hams. 9BTH reports 9BAY moved to the sixth district with the call 6GN, and 9BBU a new station operated by an old ham, 9AZF. 9CEC reports ND this month. 9CIA worked up and to last month. 9CKM is a new op working in the 80 meter band. 9CKZ is operating regularly. 9CEN is having trouble keeping DC QSB as filter condensers go south. 9CNB, operating on 41 meters reports, his H tube gone west. 9CNY is keeping schedules with 9BLL and reports their traffic working with commercial precision. 9CSB has a brand new 204-A and zap antenna. 9CUH worked WNP and is keeping skods with 4VZ. 9CWC worked J2. 9CYN is using a 201A tube and worked 6RUF with a report of R5. 9CZL was QSO with England. The station is decorated with a new DC generator. 9BI is keeping a schedule with 9NV daily. 9DGA reports QRM had in all bands. 9DOX has a schedule with 9RLL. 9DSU is having QRM from school work but is keeping a daily schedule with 9RPX. 9DWP is QRW with railroad work. 9DXZ has five schedules and altho he changed his antenna to a new location, he didn't miss a one. 9DYD worked his station after the CRTA banquet. 9DXG was not very active this month. 9EAI has six schedules, and will be operating on 80 meters with a 250 watter soon. 9EAJ has been working his station with 7½ and 50 watters to tickle the antenna. 9EDS was QRW with basket-ball and other things. Hi. 9EGX is planning to QRO soon. 9EHK is crystal controlled now. 9EIO has been working nc's and np's with a 210. 9ELR is operating in the morning hours. 9ENL is a new ham. 9EPG, another new ham, has worked some sixty stations since he got his license a month ago. 9ERH is a new station of an old ham who used to work 9DZ in 1921. 9GE is operating on 80 with spasms of 20 and 40 meters. 9FZ is using a 210 and a Hertz. 9KA is having interference trouble. 9NV is using an ancient 204 in hopes that its feeble efforts will put strong signals into the ether. 9QD is operating on 20 meters. 9VO was thrilled on Thanksgiving

Day by hearing fo-A3Z about R6 on 20 meters at 2 pm.

The Chicago Radio Traffic Association held its second annual banquet at the City Club, Chicago, Nov. 5, 1927. This feature has now become a recognized annual Chicago affair. Supervisor Beane acted as toastmaster for the 147 speakers. Director Clyde Darr, 3ZZ, came all the way from Detroit, a gang came from Wisconsin, Indiana, Iowa, Illinois, all with the same old A.R.R.L. spirit. With musical selections rendered on the piano and violin by the Siebens, the many stunts of the evening were enjoyed by all. Howard Thomas, 9LY and Harry Irons, 9DYD, deserve to be complimented for the way they put on the affair.

Traffic: 9DXZ 261, 9AWX 147, 9BPX 144, 9NV 91, 9AFA 86, 9APY 79, 9GE 68, 9EAJ 62, 9CCZ 60, 9AMO 58, 9ACU 59, 9CNY 57, 9BLI 52, 9BTL 46, 9EDS 44, 9ASE 39, 9DBI 39, 9DOX 39, 9CZL 35, 9TZ 34, 9CZL 34, 9DSU 32, 9CNC 30, 9AFF 22, 9EJO 24, 9DYD 23, 9CUH 22, 9QA 21, 9BL 20, 9BWL 18, 9CSB 16, 9EAI 14, 9AAW 15, 9AEG 11, 9DGA 11, 9ALK 10, 9BXB 10, 9BHM 8, 9EXG 8, 9ELR 8, 9CIA 8, 9UX 8, 9AHJ 7, 9CYN 7, 9AGG 6, 9EPG 5, 9BNI 5, 9CWC 5, 9BHT 4, 9EHK 4, 9QD 3, 9DXG 2, 9ENL 2, 9KA 1.

WISCONSIN—SCM, C. N. Crapo, 9VD—The past month has been an eventful one for the SCM. Nov. 22 brought a 6½ pound baby girl, Jewell Audrey, 9LV is one of our best stations for contact in Milwaukee and you will find him always on the job and always ready to QRS. 9DLD is sending schedule charts to all stations with whom he has schedules. 9DTK is trying out an interlocking schedule list with all stations he has skeds with. 9DLQ's skeds are working fine and he can QSR to any part of the state now. 9XH-EK heard PCLL, Kootwyck, Holland, on 20 meters and the next day worked it. 9SO is on both 20 and 40 meters now. 9DX was good this month. 9BJY's chem rectifier is on the bum so he is thinking of changing to kenotrons. 9BPW worked a Calif. Station for the first time. 9BIT has schedules with 9VL and 9DLQ. He is QRW at St. Norbert's College and operating WHBY. 9BIB has a little more life as his total shows. Also has a new Ford (1915). Hi, 9ABM says the two R. F. wires that run out around the porch, light the porch light dome every time he presses the key. Hi, 9AZN has schedules with 9DTK Mon., Wed. and Fri. at 5:30 pm and is arranging schedules with 8ARC on 78 meters. 9EFC has worked all U. S. and Canadian districts but outside of hearing a lot of foreigners, hasn't been able to QSO any yet. 9EHD's total this month is pretty small but that is on account of having so many exams. 9BWO has been trying 20 meter fone but so far, the results are rather poor. 9BAW has a low total because he hasn't been on due to experimenting with xtal control. 9AFZ reports nothing new or exciting. 9ARE is on both 40 and 171.5 meters. 9EGW operates on 20 without schedules. 9COI operates on 39.5 when he can find time. 9CVI is back on the air after an absence of several years. (Welcome, OB, perhaps we'll see you at the club occasionally now, SCM).

Traffic: 9LV 262, 9DLD 223, 9DTK 221, 9DLQ 120, 9XH 72, 9SO 70, 9BJY 63, 9BPW 57, 9BIT 57, 9BIB 41, 9ABM 39, 9AZN 27, 9EFC 23, 9EHD 12, 9BWO 16, 9BAW 15, 9AFZ 9, 9ARE 5, 9EGW 5, 9COI 2, 9CVI 1.

DAKOTA DIVISION

SO. MINN.—SCM, D. F. Cottam, 9BYA—Through the persistent efforts of a few hard working amateurs, there is a new radio club in Minneapolis. The "West High School Radio Club," operating under the call 9ERT. There is some real ham spirit in this new organization and a good deal of thanks is due 9DHP for the fine way the new, well-organized club is functioning. A number of students are learning the code and also the deeper mysteries connected with a junk pile, that they may be ops and help put 9ERT on the map. There have been 5 cancellations this month. More traffic is highly desired so get all skeded up and handle more traffic in an hour than you can in a week without skeds. 9BTW, a new ham in the section, is high traffic man this month. He is on 20 and 40 and his best DX was "XEN-OSQ." 9XI has a good staff of ops and is QSO the world. 9DHP has one sked and has boosted his traffic a lot. His QRH is 20.4

QST FOR JANUARY, 1928

and he wants another sked with Oregon or California, to handle his west traffic. Oh yes! He has an 852 on the air and he is working it overtime too. Hill Hill 9BHZ praises his new mercury arc. He sez it is the best rectifier yet and that he gets d.c. reports. FB, OM, 9CIX has a new 250 watter in a Hartley circuit. 9AIR sez he blows up too many stopping condensers with 500-cycle current. He lost an antenna in a silent storm but is gg again now. 9BYA has a new branch of work and has been very busy during the last two months. 9AMD is off the air while he is attending the "U" but he ops at 9XI. Be sure and listen for 9ERT. With their staff of ops the station should be heard often. 9DEQ is back on 40 and he expects to be on the air more. 9DBW has been making various changes and has been busy broadcasting the news received from Headquarters.

Traffic: 9BTW 48; 9XI 45; 9DHP 29; 9BHC 23; 9CIX 20; 9EFO 15; 9COS 13; 9EFK 12; 9DBC 10; 9BKX 8; 9ELA 6; 9AIR 4; 9DEQ 4; 9DBW 2.

NORTHERN MINNESOTA—SCM, C. L. Barker, 9EGU—This Northern Minn. Section has an ORS membership of 29 stations now. Last month, we brought up the subject of cancellations in this Section and we are going to live up to those statements. Out of the 29 ORS, there are 9 stations who are going to lose their ORS appointments because some have gone 11 months without reporting. Some of these will be cancelled honorably if they have legitimate excuses. The SCM believes it is much better to have a small membership of ACTIVE stations than a large organization of DEAD stock. 9BVH has gotten 9AIB's crystal set on the air and is rebuilding his own rectifier, getting ready to be on the air regularly for the winter. 9KV has not had time to operate much so far this winter but is now on for good. 9AOK, the traffic wizard of this Section, sure steps out this month, leading the works. He shows us very definitely that good traffic totals can be built up, working good DX at the same time. He is in line for WAC. 9CKI is busy with school but has a new UX852 and has it on the air. 9EGU is at last on the air but just temporarily with the old chemical rectifier. A new complete mercury arc outfit has been ordered from 8ML and as soon as it arrives, there will be nothing temporary about 9EGU. 9QT, the Minn. Nat'l Guard station has been moved 9EHO received a Burgess flashlight for the best report on work with 9XH. FB. 9CIY put up a 90 foot tower and rebuilt and found that he couldn't get out at all but seems to be overcoming the jinx at last. 9CSU, the other station (sister sin to 9CIY) is to be an A-A station soon. Ryder owns and operates both 9CIY and 9CSU. 9CWA works at 9CSU-CIY and does most of his operating there. 9BJD has a new voltage-feed Hertz working FB and gets out fine. 9AKM found out that he was lighting basement lights but he shunted the lights with condensers and found that his wave steadied up a lot and gets out much better.

Traffic: 9AOK 107, 9CKI 43, 9QT 40, 9BBT 37, 9DPB 24, 9ABV 23, 9CTW 13, 9EGF 13, 9EHO 11, 9CWA 10, 9BJD 6, 9CIY 5, 9AKM 4.

SOUTH DAKOTA—SCM, F. J. Beck, 9DB—Traffic dropped off somewhat this month, which is rather unusual. The Y.M.C.A. Radio Club of Sioux Falls, has received a number of prizes for the convention and have the program nicely arranged so everything is set for our 7th annual convention. 9DGR's beautiful note and the fine operating plus a few skeds turned him in high traffic man this month. 9DWN was very QRW work and says tfe not so good. 9BKB at School of Mines handled a fine bunch of messages in spite of no skeds and QRM studies. He reports 9DBZ and 9DZI are coming on the air again soon, 9DB will be glad when summer comes and the BCL work lets up so he can run the xmitter at least once a week. 9NM says 40 and 80 bands are the bunk from QRM but is on 80 working tfe. 9DLY is on 20 and 80 and wants skeds. 9RBF is back with us again and on with 15 watts and lining up a bunch of new stns in Watertown, FB, OM. 9CJS says it takes too much juice to run a 50 and is fixing up a low power set. 9BOW gets out FB and is looking for skeds. 9EY has been appointed an ORS. 9AJP, 9DNS and 9DES are active but no traffic report. 9ID is the call of Nick Jensen (EX-DEM) Sioux Falls.

Traffic: 9DGR 127, 9DW 64, 9BKB 32, 9DB 14, 9NM 9.

DELTA DIVISION

TENNESSEE—SCM, L. K. Rush, 4KM—Activities in this section have improved considerably in the last month. Quite a number of new stations are on the air and there is room for several new ORS in this state. Quite a bit of activity has been going on in Knoxville where they have formed the Knoxville Amateur Radio Club and have quite a large membership. 4FI craves a record of your schedules as he is the Route Manager and still continues to handle lumps of traffic. 4CU is using a 204-A and teasing the plate with 3000 d.c. fm a mercury arc tube. 4BU is still "messing around." 4KP uses a 250 watt and has a very neat station. 4ABZ is getting out fine with his 852 and is on the air regularly handling traffic. 4HK is a new station and with the help of the gang will be on soon. 4FX, 4DG, 4GL and 4SP are all on the air looking for traffic. 4PD is at UT and took his transmitter with him. 4ABD is going strong and is getting good results with a "fiveer." 4KM and 4KX are still banging away on 20 working ex's, sa, sb, oa and oz's regularly. Traffic: 4FI 160; 4CU 24;

ARKANSAS—SCM, W. L. Clippard, Jr., 5AIP-5ACA—Amateur activities in Arkansas the past month were almost nil, but we can always depend upon a few old timers to keep the ball rolling. 5SS received a bad gash on the head when a pole which he was putting up for a BCL fell on him. Better leave the BCLs alone, OM. Hi. Has anyone finished that coffin for the PB gang? We are about to forget there ever was a PB amateur. 5AIP is on with a 50. Hi. Our old friends, 5ANN and 5HN are on again. 5ZAA promises to be back soon. We certainly hate to lose 5SY who is leaving for Texas. Let's all get together, fellows, and see if we can't beat all our previous records this next month. All Arkansas amateurs who have not communicated with the RM or SCM, please do so.

Traffic: 5ABI 14, 5AVA 6, 5SS 2, 5JK 2.

MISSISSIPPI—SCM, J. W. Gullett, 5AKP—Reports were light this month. 5AJJ, if you want to keep the ORS, you will have to report every month. 5FQ is working lots of stations on 40 meters and is getting so he can handle messages right along. 5QZ leaves next week for Calif. and is carrying his 250 watt along. 5YD reports copying an important message from 1YD during the flood in Vermont. He was Norwich's first contact after the flood. The message was delivered from 5YD by telegraph to the Dept. of Justice, Washington. D. C. FB, OM. 5AKP blew another UX210 but is back on with a new one. 5AYB who was an Instructor at the Harvard Univ. Radio School during the early part of the world war, ex1ATV, has been appointed an ORS. His operation is unexcelled in this neck of the woods as he receives and transmits at 30 per without any trouble.

Traffic: 5AKP 56, 5API 12, 5FQ 12, 5YD 6, 5AYB 38.

LOUISIANA—SCM, C. A. Freitag, 5UK—The message total has dropped somewhat this month, but is still a little above the general average. Route Manager Swanson, 5PM, reports that message delivery is improving and that he hopes to soon have a network of stations all over the state. 5IE is not very enthusiastic about the "20" band. He hears the same stations every day and most of his traffic is on 40. 5AOZ shows the right spirit. Although his ORS application was rejected, he writes, "I am very sorry to hear that I did not pass my ORS examination but I suppose it is for the best as I am very unfamiliar with the theoretical points of radio but as a message handler, I am going to show you." 5KC reports he was QSO ef-8CP on the "40" band. All the boys in this section want to thank Headquarters for their efforts at the International Radio Conference and to congratulate them for the results obtained. Although our bands were somewhat cut, we should be very thankful that we were not entirely eliminated.

Traffic: 5PM 105, 5UK 38, 5IE 26, 5EB 21, 5AOZ 18, 5NS 13.

HUDSON DIVISION

NEW YORK CITY & LONG ISLAND—SCM, F. H. Mardon, 2CWR—Manhattan: 2ANX hopes to be back on the air soon. 2BCB is on 20 meters during the day and 80 after mid-

night. 2BNI is on 40 and 80 meters now. 2EV has been appointed Asst. to the Section Manager and is making his first report to HQ.

Bronx: 2BBX is doing good work on 20.8 meter fone now. 2CYX operated 8WK for a while but is back to stay.

Brooklyn: 2AVR has a mercury arc now and says it is the berries. 2BAZ changed from LCH to TPTG and is working foreigners now. 2BDM has schedule with 8CEO and wants others. 2BRB working fone FB with his xtal on all waves. 2CRB is on 37.7 meters. 2CTY is on 20 meters or below most of the time and expects to put in a 250 watt soon. 2PF is putting in UX-2S1 tubes for rectifying in place of his 4 year old slop jars. 2WZ has been SAOC at Princeton, N. J. while at school there. 2AIZ is going to put in kenotrons when his slop jars freeze. 2ALS is now in Long Island City and is going again on 40 and 80 meters. 2AWQ is still at it but nothing new to report. 2BSL is now using TPTG in place of Hartley and says the Queens Radio Club Station 2ATF is now on the air.

Richmond: 2AFV is handling some Aussie tfe now and is on regularly on 20, 40 and 80 meters. 2AKR reports two new hams, 2WT in New Brighton and 2WF in West Brighton. 2AKK is operating the s/s Gulf Oil now and away most of the time.

Traffic: Manhattan: 2BC 13, 2BNI 8, 2EV 78. Bronx: 2AET 5, 2AWU 52, 2BBX 97, 2CYX 52. Brooklyn: 2AVR 22, 2BAZ 7, 2BDM 22, 2BRB 6, 2CRB 42, 2CTY 3, 2PF 10, 2WZ 23, Long Island: 2AIZ 41, 2AWQ 8, 2BSL 1. Richmond: 2AFV 217, 2AKR 24.

NORTHERN NEW JERSEY—SCM, A. G. Wester, 2WR—A large number of ORS reported this month and the Section is coming back into its own once again. 2CP, one of our RMs, is having fine success in gathering traffic from scheduled points but has a hard job getting the ORS in Monmouth, Union and Middlesex Counties to get lined up for local traffic distribution. Two jobs for RMs are still vacant and refer to Dec. QST for the territories. 2CPD and 2CYV have resigned from amateur radio and have given up their ORS certificates. 2CJD of Jersey City has been appointed an ORS and is a fine station for traffic. 2AT is away on another trip which keeps that station silent. 2CP takes honors for traffic, making the RPL. 2CW pounds out on 20 with his 210. 2EY seems very much put out by the new regulations for 1929 but let's not kick until the time comes. 2JC is on every night with a different operator and wants some schedules on 38 meters. 2FC reported by ship off Hong Kong, China on 37 meters. 2KA finds it hard to get time to operate but wants to get in on some schedules. 2IS very QRW in a BC station. 2AVK asks that I correct the fact that he did not blow his 60 cycle transformer on 500 cycles but that 2IE was responsible for the act. 2QI is off due to blown filter condensers. 2ADL worried over what they did to us at the battle of amateurs in Washington. 2JX also has too much BCL work. 2AOP maintains schedule with 2CP for all Newark work. 2GX has been appointed an Ensign in the USNR and is now helping build a new transmitter of 250 watts for NRRC. Our YL station, 2BY, has installed a 210 and was QSO the 9th district for the first station worked with the new high power. 2AAT is very badly in need of schedules and hopes some of the amateurs will get in touch with him. 2WR will be on the air Jan. 1 and thereafter.

Traffic: 2AT 6, 2CP 212, 2CW 7, 2EY 5, 2JC 7, 2FC 2, 2KA 2, 2ASZ 4, 2AALM 6, 2AGN 2, 2CTQ 4, 2CJX 22, 2AVK 17, 2ADL 39, 2AOP 36, 2GX 31.

EASTERN NEW YORK—2BOW is now an aviator in spare time. He was QSO ef-8JF who was using phone on 300 watts.

MIDWEST DIVISION

NEBRASKA—SCM, C. B. Diehl, 9BYG—Route Manager's Report: Everybody has been QRX on account of bad weather conditions and also the Radio Commission but expect more activities from now on.

It is with regret that we learn that 9CNN is forced to resign his radio work and retire from his position on account of ill health. We hope for your speedy recovery. 9QY is having another stroke of work on his farm but says it can't last always. 9EEW is also having a stroke of good work on his railroad and

between that and "observing", he is a busy man. 9EBL is rebuilding with Xtal. 9CJI missed traffic this month on account of QRW the new printers in the A. P. office where he works. 9CDB turns in an excellent total this time and also inquires about an ORS. 9ANZ also feels that he can handle an ORS appointment now. The SCM is busy with Army work and hasn't much time to be on the air.

Traffic: 9QY 6, 9REW 2, 9BYG 5, 9BOQ 7, 9BQR 3, 9CDB 14.

IOWA—SCM, A. W. Kruse, 9BKV—Only half of the ORS reported this month. All ORS who have failed to report during the last few months will be cancelled by the time this appears in QST unless they get busy and handle traffic and report same to the SCM on the 26th. We have a good bunch of non-ORS who are doing excellent work and credit is given them for helping to keep the section on top. Thanks for your fine work, OMs. 9BKV is using a battery operated transmitter and leads the Section in traffic. 9BWN comes second and he reports some new hams in Des Moines. He is going to try and reorganize the Capitol City Radio Club. FB. 9CZC had bad QRM from the Telephone Company's Motor but he manages to keep a good bunch of skeds. Watch 9DGW's smoke next month! He has applied for ORS. 9EJQ is lining up some schedules and will soon be set to go. The YL's QRM 9EHN a lot but he keeps the traffic moving just the same. 9DZW turned in his usual fine report by radio. 9BAT's total dropped this month due to a death in the family. Sorry, OM. 9DEA spent a couple of weeks in Chicago and his total looks like it, too. 9CJL reports a sked with 6CUX but says traffic is slow. 9AMG says everything is perking FB. 9CAC hopes to get going good soon.

Traffic: 9BKV 338, 9BWN 251, 9CZC 210, 9DGW 137, 9EHR 53, 9EHN 51, 9EJQ 50, 9DZW 40, 9BAT 25, 9DEA 18, 9CJL 16, 9AMG 3, 9CAC 3.

MISSOURI—SCM, L. B. Laizure, 9RR—Director Quinby reports that he was out of town most all month and only on the air twice. Something is radically wrong when only four reports come in from a city like St. Louis. The following stations reported. 9BEQ, 9DXY, 9DLB and 9BEU. 9BEQ almost hit the GPL. 9LI is the latest addition to the ORS list. 9DKG is still tied up with school QRM. 9DAE is battling the sked proposition on 80 meters, and reports a failure to cooperate with RMs in adjoining states poor with the exception of Iowa. A sked has been made with 9CZC for RM QSO. 9BQS and 9DAE handled a football game report sked during the month. 9DMT kept a sked with 7AIL nightly when possible. 9CRM worked 103 different stations, kept skeds with 5 stations, and relayed one government msg ek 265 words. 9DAE complains of trouble with a well known Chicago mail order house advertising extensively in popular BCL magazines. 9ZD or 9RR will be glad to order ham stuff for you and no doubt, someone in St. Louis will, too.

9BKK, the seagoing brass pounder of KC, came near the BPL this time and takes the prize in KC. 9ZD was out of town a good bit and was not able to operate as often as usual. 9RR is coming back slowly. 9DQN had a fair month but was handicapped by being obliged to work a split trick at the Western Union. 9ACA, 9EMH and 9DLL were on occasionally and handled a few msgs but the SCM was unable to get the reports. 9BSB is back on the air after a long absence. 9WV is keeping on the air and gets quite a few cards. 9FMH is running the ham column in the K.C. Post Sats. with the help of 9ACA and 9ZD. Watch out for it in the radio section, gang. 9DQN sends the A.R.E.L. broadcast per his skeds in December QST.

Traffic: 9BEQ 92, 9DXY 11, 9BEU 17, 9DLB 18, 9LI 34, 9DKG 15, 9DAE 54, 9BQS 5, 9BUL 22, 9DMT 4, 9CRM 76, 9BKK 93, 9DQN 15, 9ZD 5, 9RR 3, 9DLL 2.

KANSAS—SCM, F. S. McKeever, 9DNG—Hear ye! Hear ye! The honorable 9JU of Independence, Kans. offers a traffic trophy to the *Kansas* ham who has the largest message total between dates of Jan. 1st and April 1st, 1928. The SCM will be the judge. Who will win this Trophy? Now is the time to make preparations and schedules, fellows!

9BII is jumping forward with leaps and bounds. 9BET, 9BUY and 9CNT are active in traffic handling. 9CET has been away two weeks but handled some traffic. 9ARK and 9BHR promise more activity in the future. 9CV says he will soon have a new

FB low-loss transmitter going. He does not need it as he worked eg, oa, ef, oz and ed this month. 9JU has been appointed Asst. RM. 9BGX has been off all month but you can't keep a good ham down long. As usual, 9CFN turned in plenty of traffic. He and 9HL are always on the job. 9CWW, 9CCS and 9DNG are all at college but the latter is on occasionally anyway. 9CKV is still having trouble finding schedules. How about it, fellows?

Traffic: 9LN 22, 9DNG 32, 9CET 32, 9CKV 45, 9CFW 6, 9BUY 15, 9CNT 20, 9CV 26, 9HL 51, 9AER 1, 9BET 20, 9CFN 20, 9EBM 12, 9CLR 7.

NEW ENGLAND DIVISION

VERMONT—SCM, C. T. Kerr, 1AJG—To have the honor to chronical the most important feat ever accomplished by Vermont amateurs is indeed a pleasant one. And to these earnest young men who filled the gap and bridged the rushing waters were simply say, "Well done, Hams." Few people in the stricken towns knew that the amateur could connect them with the outside world but when they did get wise to the fact the boys were doing SOME business. I think that the remark "You spoiled my program last night" will not be heard for a long time. 1BBJ handled 371 msgs comprising all phases of relief work and to him goes the honor of high traffic man. Think of it men! He delivered 158 msgs. Great work, OM. 1BEB also of Montpelier was right at the key doing his bit too. He handled 307 msgs. Kept 12 schedules, and for 7 days was at the key from 7:00 a. m. to 8:00 p. m. His traffic also comprised all phases of relief work such as Red Cross, Signal Corps, AP, and etc. SOME service, OM. Our tireless CRM 1IT at North Troy was also the only source of communication in his Town for four days and cleared 124 msgs. He was the connecting link between RR op and his dispatches. 1IT pwr has a spark coil xmtr. 1BEB used 18 B Batteries. 1BBJ sounded like spk coil too. 1YD at Northfield slammed out 318 using a motorcycle belted to an a.c. generator and Gray "the ham wat am" handled real stuff too, including U. S. wx Bureau rpts etc. 1BJP had 79 msgs, used B Battery pwr. His work was handling msgs for Canadian Pacific es B&M RR as railway telegraph ng. They were important and a compliment to our boy's reliability. Nice work, OM. 1EZ was slamming them out with a 301-a and spk coil pwr total 74 msgs. 1BDX was doing a land office business in Barre but no mails so didn't get his report. Got a clipping out of the Barre Times abt him and they say in a column and a half that George sure ripped the stuff out. Congrats, OM. 1ATZ was on the air with Press a week, hrs were 9 a. m. to 3 a. m. That's REAL HAM Stuff! 1FN had sold most of his stuff so he couldn't do all he wanted to. 1AC handled press thru to Boston from Rutland. 1AJG had 35 msgs and called 1BBJ every time he hit the air and couldn't raise him. 1NH is on the air most every night between 7 and 11 p. m. using a 7 1/2 watt. To the HAMS who copied our weak and sputtery signals we are more than grateful and all sure helped us bridge the gap. Let me repeat again Boys, WELL DONE. 1AJG.

Traffic: 1ATZ 8; 1EZ 74; 1BJP 79; 1AC 38; 1AJG 35; 1YD 318; 1IT 124; 1BEB 307; 1BBJ 37; 1NH 20.

MAINE—SCM, Fred Best, 1BIG—Several of the Maine gang handled Vermont flood traffic and did a good job of it. Such emergencies give us the chance to prove our worth, gang, therefore, we should be prepared at all times. 1BFZ handled his usual good total and as traffic was low over his way, failed to make the BPL for the first time in months. 1QY handled Vermont flood traffic. He seemed to have about as good luck tying up with 1BEB as OM 1BIG did. Hi. 1AQL sent in his usual string to add to the Maine total. He reports that 1AUC of Bar Harbor is in the hospital recovering from an operation. We hope that OM Sprague will be back with the gang as soon as his condition permits. 1ATV has acquired a 250 watt and is sure kicking out a mean signal. 1CFP has installed a new 75 watt jug with which he is proceeding to get out in great shape. 1AUF is on more or less on both 40 and 80 meters. He has been ill according to 1BMS but manages to get on the air real often just the same. FB, OM. 1BTQ has started up again in Skowhegan. He has a very neat looking layout. 1KL is still operating at WCSH. 1ABV is building a new receiver and con-

tinues to get out in the usual good fashion. 1BIG lost his good note, but found it again. Hi.

Traffic: 1BIG 135, 1BFZ 72, 1QY 65, 1AQL 43, 1ANH 18, 1AIT 11, 1ASJ 5.

EASTERN MASSACHUSETTS—SCM, E. L. Battery, 1UE—Well, gang, there was plenty of activity this month, much of which was aroused by the flood disaster in Vermont and Western Mass. The following stations did valuable work during the same: 1FL, 1ACH, 1KY, 1SL, 1ASI, 1AXA, 1UE, 1APK, 1IN, 1BZQ, 1LM, 1AGS, 1AAW, 1GP, 1RY, 1ABA, 1WV. The space does not permit us to go into detail about the work, but will say that 1FL and 1ACH kept about the most consistent communication with the flood areas. 1FL stood 120-hour continuous watch from Nov. 4 to 9.

1KY has been appointed RM and sent in a good report right off the bat. FB. Traffic figures were quite high this month with four stations in the BPL. 1WV and 1AKS are new ORS and 1AYX has resigned as he is QRW at W.U. at Rahway, N. J. 1ABA is still in the DX group but handles some traffic. 1AWB has a temporary set on 80 meters using 201A with B bats. 1AKS uses remote control with separate xmitters for 20, 40 and 80. 1BKV sticks to 20. 1ACA is again handling traffic. Things are picking up at 1GP in both traffic and DX. 1RY worked fo-ATN two afternoons in succession. 1AAW is lining up some skeds and will be an ORS soon. 1OG has been QRW at the Y.M.C.A. and with Radio Service work. 1LM can be found handling traffic most any night. The 150 meter band is being revived by 1BVL who has a schedule with nc3GG. A bunch of the fellows went to the Worcester Convention and had a fine time. 1AXA is at WBZ. 1ASI expects to have schedules soon. 1NK likes his new TP-TG circuit. 1APK kept some skeds during the flood. 1SL, at request of Signal Officer, established message center between Washington, D. C. and N.E. flood area for traffic. 1IN, although non-ORS, sent in a FB report. 1BDV participated in Navy Day copying but school keeps him quite occupied. The 60 ft. mast at 1ADM came down which handicapped activity. 1BZQ says, "Let's hope for more traffic and less floods next month." Hi. 1AGS works Europe every night and Calif. every morning but he says no one has any traffic. Why not originate some, OB? 1BMS passed his commercial license.

Traffic: 1ACH 317, 1AKS 183, 1LM 176, 1KY 175, 1UE 133, 1BZQ 120, 1ACA 90, 1AXA 64, 1AAW 58, 1SL 52, 1APK 50, 1GP 44, 1ASI 44, 1ADM 36, 1IN 118, 1RY 27, 1KH 25, 1ABA 22, 1WV 20, 1AGS 15, 1NK 9, 1BDV 5, 1YC 4, 1AWB 4, 1OG 1, 1ON 1, 1BVL 1, 1BMS 19.

CONNECTICUT—SCM, H. E. Nichols, 1BM—This month records another chapter in the history of our worth to the general public as amateurs in the calamity that occurred to our neighbors to the north in Vermont. Everyone who took part must have sensed the fact that they were doing something more than just playing with a wireless set and also realized the valued service they could render in times of an emergency. May we always be on the alert to perform our duty in such times as this and in that way, show that we have a real reason for existence other than our own pleasure. 1MK leads the list this month for traffic handled and reports having 17 different stations lined up for schedule work. 1ATG worked 1CTI on 20 recently and was surprised to think he could work at such a short distance on this wave. 1BHM reports that the stations in New Haven handled quite a little of the Vermont traffic from the flooded area and we are very glad to commend them for it. 1MY says he is on the job most of the time but doesn't seem to hear the SCM. Well, OM, be patient. 1OS reports things very FB at Danbury and turned in a nice report. 1ADW is hoping to get all fixed up and ready to go soon as he has been moving things a bit due to cold weather. 1IV and 1ZL have been so busy at WICC that they have been unable to get on the air but hope to soon. 1CTI and 1BWM have been keeping the ether in working condition at Norwalk and have maintained schedules in fine shape and things are working very smoothly in this section of the state. 1VB, 1NE, 1PE in their respective cities have adopted and arranged schedules with their nearest neighbor and in this way are covering their locations very efficiently. This is very encouraging to see the stations take the initiative in this way and we thank you fellows for

doing it. 1VE is handling quite a bit of the local traffic when the SCM is out for the evening and is very prompt in delivery to him. He will be an ORS very soon and has ambitions for an A-A appointment. Clifford Fraser handled 79 flood relief messages this month.

Traffic: 1ACD 2, 1BLF 4, 1ASD 3, 1ADW 7, 1TD 10, 1AMC 18, 1ATG 18, 1BM 20, 1BJK 22, 1ALF 23, 1BHM 26, 1MY 27, 1BWM 42, 1OS 47, 1AFB 50, 1AOI 63, 1VB 68, 1CTI 153, 1MK 266, 1NE 11, 1VE 14, 1AMG 16, 1BNS 85, 1PE 68.

WESTERN MASSACHUSETTS—SCM, A. H. Carr, 1BD—1AAC is on regularly on 38 and 76 meters and handled several of the flood messages. 1AAL, our former RM, has moved to 53 Calder St., Pawtucket, R. I. SCM Fancher will be fortunate to have Brownie as an ORS in his Section. All 1AAL's friends around here will be able to work him from his new QRA as he is on the air already on the 80 band. We all wish you the best of luck, Brownie. Al Hyde, 1GR, 19 Caro St., Worcester will act as Chief RM until another RM is appointed. We hope you all got the kick out of the Worcester hamfest that we did. The Worcester Radio Assn. appreciates the wonderful support that all gave to the time and undoubtedly we'll have another sometime. 1AJK says he will be on for the rest of the winter now. He stood 12th in the Navy Day broadcast reception. 1AJM says that now fone is on 20, he'll sell out for a nickel. I wonder if more of you don't feel the same. 1AKZ is working on all three bands now and is QSO about all the E's with one 210. 1AMZ got a few of the flood mgs but says he was too late for the bulk of the traffic when he got home. 1ANI says tough that they raised the BPL requirements. He got a good total for a new ORS. 1ANI, 1AJK, 1BOE, and 1BKQ made the honor list in the Navy Day contest. 1ADO, a non-ORS, helped us along by sending in a report. It would be fine if all of you did that. 1AOF says he had a fine trip to N.E. as guest of nc-1DU and got lots of big trout and plenty of game. He will be on the air from 4DN as he is in Florida now for the winter. 1APL lost about \$150 worth of radio stuff in the recent floods but saved enough to rig up again. FB. 1AQF and 1WQ handled some flood mgs. We wish you all a Merry Xmas and a Happy New Year.

Traffic: 1AAC 48, 1AAL 86, 1AJK 26, 1AJM 43, 1AKZ 20, 1AMS 1, 1AMZ 13, 1ANI 137, 1ADO 17, 1AOF 4, 1APL 76, 1AQF 20, 1AQM 44, 1AWW 30, 1BSJ 6, 1DB 22, 1WQ 11.

NEW HAMPSHIRE: V. W. Hodge, SCM, 1ATJ. More reports were received this month than ever before; 12 stations reporting. Practically every station handled urgent traffic with stations in the Vermont flooded area. Our Section proved itself equal to the emergency. New Hampshire also was well represented on the Navy Day Honor Roll by 1IP, 1BFT, and 1ATJ. 1IP succeeded in making the RPL in spite of the more rigid requirements. He is keeping TEN skeds daily. St. Paul's School, 1ASR, is on again. 1JN and 1AVJ are on daily. 1AOV has been away. A good report was sent in by 1YB. 1AOQ and 1ANS are doing their share. 1BFT claims the low power record for N. H. by working 1ATV in Skowhegan, Me., with 2 watts input. 20 meters accounted for 6 of 1AEF's tubes. Hil 1TA and 1BFT relayed the score of the Concord-Nashua football game and beat W.U. by 20 minutes. 1TA also relayed score of the Meriden game with 1TV. The SCM is now a member of the U. S. N. R. and welcomes inquiries about joining the Naval Reserve.

Traffic: 1IP 233; 1ATJ 149; 1AEF 90; 1YB 82; 1ANS 67; 1AOQ 65; 1BFT 54; 1ASR 34; 1JN 19; 1TA 16; 1AVJ 15; 1AVT 6.

RHODE ISLAND—SCM, D. B. Fancher, 1BVB—HOOORAY!!!! A 100% report again this month. Every ORS got in his report and got it in on time!

That is not all either. There are two stations that are becoming ORS and their reports will be included next month. And one more thing. 1CKB and 1AMU are back on the active list again.

1EI is experimenting with antennas. Get a good one, OM, and let's go. 1CKB has been to sea with ECEP. He handled some flood traffic and QSRed some of it via Western Union. FB, OB. 1AQP is keeping some schedules as well as doing some good DX. 1MO is held down by business and can't keep schedules. 1BIL is doing antenna experimenting also. 1BQD's xmitter went on the bum for a short while this month and held him back. He is all set now, tho. 1AWE, our star DXer is still rapping the phones of the foreigners on 20 and gets traffic

besides. 1AMU is going strong again and handled some flood traffic. 1BAT handled a 900-word flood report for the National Guard of Mass. and also a WNP message. Good work, OM. 1BVB is getting along fine now. Good DX and plenty of traffic. Traffic: 1BVB 76; 1BAT 73; 1AMU 39; 1AWE 34; 1BQD 25; 1BIL 18; 1MO 16; 1AQP 15; 1CKB 6; 1EI 5.

NORTHWESTERN DIVISION

OREGON—R. H. Wright, SCM, 7PP—7EO has been working on 80 meters lately and says that there are plenty of rag chews there for those who want them. 7ABH reports taking 2 msgs from nlnic and one from oz. 9GQ's crystal control is coming slowly on account of a night job which keeps him busy elsewhere. 7JO and 7ACQ are torn between love and duty—y's and school work. 7JC has been experimenting and is consequently minus a few tubes. 7BX is fighting chirps. 7AKK has a regular sked with 7TZ and 7AIX. cx7TO one of the real oldtimers, has at last exposed himself to the radio bug again. He will be on with the call 7AKQ. 7AEF and 7AJM are new hams in town and are promising traffic stations. ex9DDV now resides in Portland and will soon be on with a seven call. 7NP, 7AJN, and 7PF are on regularly. 7MU is a new ham, using two 216-B tubes, one 7½ w. tube in TGTP ckt. with plug in coils for all bands.

Traffic: 7JO 49; 7JC 35; 7GQ 14; 7ABH 13; 7AEF 11; 7AKK 6; 7EO 4; 7FS 3; 7AJN 1; 7PF 1; 7NP 1.

IDAHO—SCM, H. H. Fletcher, 7ST—Traffic is coming up, fellows. Let's have a big total next month and more reporting stations than ever before. 7ST and 7ABW came to the top by keeping skeds. They both made the BPL. Why can't more Idaho fellows do it? Schools closed in Boise and Nampa and cancelled 7YA and 7HK skeds, hence the low traffic totals. Things look good up 7JF's way now but he has a bad power leak. 7ACN ops at 7HK and keeps his station on the air some. 7QC still works hard in his power house. 7QA-1Y says QRM from YL, but it's all over now so he is a brass pounder again. 7EJ is on occasionally. Sorry to announce that MacLafferty of 7GW has moved to Walla Walla. We surely hate to lose you, Mac. He will have 7GW on the air this month, tho. 7AJQ is a new stn at Sandpoint. 7ACL is a new station at Mt. Home. 7AJA is knocking holes in the ether with a UX852. 7FB and 7IO are on once in a while. Many reports were received by radio this month.

Traffic: 7ST 272, 7ABB 174, 7HK 88, 7JF 35, 7ACN 16, 7QC 16, 7YA 16, 7QA 4, 7EJ 2.

MONTANA—SCM, O. W. Viers, 7AAT—Things are slowly picking up during the Fall and Winter season. 7DD has been waiting for a new quartz crystal and says things won't be very lively until it comes. 7ZU reports that he is so busy at college, he has no time for radio at present. 7FL reports hearing WNP but he says he couldn't make WNP hear him. Hi.

7EL is using a 201A on 20 with 2.2 watts input and works lots of good DX. FB. 7AFP is getting ready for winter work. 7AHG has his station built in Red Lodge now and wants the gang to QSO. 7AFM will soon be ready to go again after his misfortune with a fire destroying his home and station. 7AAT-AKF blew a flock of tubes but will install two large transmitters the first of the year. With a UX210 and no antenna system on the transmitter, he worked several eastern stations and received R5 to 6 reports.

Traffic: 7AAT-AKF 31, 7DD 18, 7FL 14.

PACIFIC DIVISION

SANTA CLARA VALLEY—SCM, F. J. Quemont, 6NX—6BVY and 6AMM kept the P. I. route hot this month. 6BVY with 251 msgs led the section but reports with regret that op1AD is leaving in December, leaving him without a sked. 6AMM is clearing his PI traffic daily thru several U. S. stations. 6AMM also instructs code classes at SCCARA. 6BMW, the OO and RM, was laid up all month. Glad to know you are better, OM. 6ACQ has just been appointed additional OO for the section. 6CJD reports that he may leave any time for South America. The section will be minus a good station when he

leaves. 6AZS hooked ARCY off the coast of Africa. 6BCH will soon have his 1000 watt going. 6MP and 6BYH hope to be back on the air soon. All ORS should keep an eye on the active stations in their vicinity and recommend ORS appointment to all worthy ones.

Traffic: 6BVY 251, 6AMM 148, 6BMW 32, 6ACQ 25, 6CJD 2.

SAN FRANCISCO—SCM, J. W. Patterson, 6VR—6CCR has rebuilt his TPTG and is at last getting the DC sigs he has been wishing for. 6PW with two UX210s is making a lot of the 50 watt station step to duplicate his work. 6PN is now the proud possessor of a pair of healthy 852s, his 7.5 watt set has some excellent DX to its credit. 6KW, a real old timer, is still with us. We wonder if he misses the old rock crusher. 6DDN once had four 210s but their spirits have since departed from this life but RCA still has plenty more. Hi. 6CXI is getting tired of putting pins in his world map—that explains the shortage of map pins. 6BUF is making a 7.5 watt set strut its stuff these days. 6BIA has been QRW with the YL. 6WS has college to worry about these days, the gang is never forgotten when he does get on. 6GW is hot over 20 meters now—has worked WNP several times and has completely changed his mind about that wave. 6ASI gets a good note from his xmitter and works the DX at the same time. 6DFS has mastered the bug, we wondered who the new commercial station was in our bands. 6VR has his new TPTG set perking.

Traffic: 6CCR 105, 6VR 85, 8GW 48, 6DFS 48, 6ASI 46, 6PW 40, 6KW 34, 6CXI 12, 6BUF 10, 6PN 6, 6WS 6, 6DDN 2.

ARIZONA—SCM, D. C. Lamb, 6ANO—6DRH is a new station located at Grand Canyon, Ariz. 6DRH was formerly a 5 but has joined the 6th district. Very glad to have you with us, OM. 6DCQ is troubled with a power leak so finds it difficult to work thru it. 6CJB reports YL QRM but will be back on the air soon with an 852. 6BWS burned out a 7½ watt. The YL keeps him broke so has to use a 201A with AC. He says "Don't fall into the fifth stage of ham radio". Hi. 6DLE is doing good work now. 6SW, ex6CUW, is back after vacation, using TPTG. 6AZM likes MOPA fine. 6CAP is using TPTG and 852 tube on 20 quite a bit. 6GS will be on soon with low power. 6BHC is on regularly and doing good work.

Traffic: 6AZM 3, 6DRH 14, 6CAP 21, 6CDU 23, 6BJF 15, 6BWS 2, 6ANO 16, 6DCQ 12.

PHILIPPINES—Acting SCM, J. E. Jimenez, op1AT—This report received by radio from op1AT and nu6BJX—op1HR again easily leads the Section. Skeds were kept with op, ac, oh, nu, op1DR made good traffic with the SS *Salvager*, plying interisland ports in southern waters. op1DL also made a good showing by making the BPL for the first time. op1AT hands in a fair report but is QRW college and business. op1GZ didn't get started until late with a 50 watt. Traffic will no doubt increase with the approach of the holidays.

Traffic: op1HR 504, op1DR 170, op1DL 84, op1AT 22, op1GZ 2.

HAWAII—SCM, J. A. Lucas, oh6BDL—This report received by radio from oh6BDL and nu6AD—Our annual dead-air season between Hawaii and the coast is with us again. Few stations are report and traffic totals are light.

Traffic: 6AVL 49, 6CFQ 38, 6BDL 15; 6DCU 14, 6DPG 8.

LOS ANGELES—SCM, D. C. Wallace, 6AM—Traffic totals are not so good this month, only three stations make the BPL. 6BJX says that conditions have been generally favorable and traffic good. 6ZBJ handled a death message from ex-5ML to Australia and keeps some good schedules. 6DKX received his ORS certificate this month and gave good assistance in broadcasting the progress of the Radio Conference. 6AM handled some foreign business for the National Company and worked all continents. 6CQM sends in a good total and has been bothered with QRN. 6CUH handled some messages to the Federal Telegraph Co. 6BTS says "new TP and TG circuit sure FB for DX combined with Zepp antenna." 6CMY thinks if more fellows would get down on 20, it would make U. S. traffic duck soup. 6BVT sends in his first report altho he has been on the air over a

Year. Says he is going to report every month now. 6BVM handled a "touch" message from AC. 6ID tried to use 9EF's dope on Split Hartley for 20 but couldn't make a go of it. 6CSW got tired of 40 after two years of it and is down on 20 now. 6IH is on 20 permanently now and is getting out FB. 6CZT has two kinds of power now, 900 cycle and RAC, both FB. 6DGT had his Hertz going one night when 9DZX saw the light and dropped in, thereby proving that a Hertz is good for more purposes than just an aerial. 6DEG has a fine antenna at his new QRA put up by 6QO. 6NW sends in a good report. 6ANN says 20 traffic is picking up. 6AKW finds wx very poor for hearing DX on 30 and lower bands there on the desert. 6DGT is keeping some good skeds. 6CNJ is very enthusiastic about his transmitter which he has rebuilt. 6CLK reports that the Whittier Radio Club has three new members, 6SJ, 7AEJ and ex9AAW. 6PY, 6DDO, 6BHR, 6DPY and 6SK also report. 6SK sends in a good report. His airplane QRM makes him too busy to handle traffic but hopes to give us some dope later on the test which they are making. 6CHY says he is going to come back with two 50's soon. 6TS is back for the east but not on. 6BHA is still operating at KFVD. 6BEO is doing experimental work around Bakersfield. 6BEK got married and has a sked for a while. YLs have captured 6AQP. 6BJX had his 21st birthday Nov. 5 and his YL. 6BXA, gave him a party. Don't forget the next banquet of the Los Angeles Section Friday, Dec. 30.

Traffic: 6BJX 395, 6ZBJ 149, 6DKX 101, 6AM 91, 6AHS 65, 6CQM 65, 6CUH 49, 6BZR 45, 6BFP 44, 6CHT 43, 6BZC 43, 6CMQ 40, 6COT 37, 6ALR 35, 6AGR 34, 6DCH 32, 6BTS 31, 6CMY 30, 6BVT 25, 6RVM 25, 6ID 20, 6CSW 19, 6IH 18, 6CZT 18, 6DGT 15, 6DEG 14, 6NW 12, 6ANN 7, 6AKW 10, 6DGT 10, 6CNJ 7, 6CLK 4, 6BRO 2, 6CAG 1.

SAN DIEGO—SCM, G. A. Sears, 6RQ—6BWI leads in traffic this month. 6AJM has rebuilt and is now using TPTG. 6BAM blew another 50 and is now on with a 7½ water. 6DGY, a new ORS, sends in his first report. 6OX is anxious for more skeds north and east. 6BQ reports 80 meters fine for traffic. 6DAU maintains 3 skeds. 6CNK reports hearing ck5DBA at 10 pm Nov. 6SB is still QRW school. 6BFE is now on with 50 watts. 6SJ has moved to Whittier and will have an ORS in the Los Angeles Section. Sorry to lose you, OM. 6CQT now pounds brass on the SS Yade. 6BYZ is again appointed RM and ORS.

Traffic: 6BWI 125, 6AJM 81, 6BAM 55, 6DGY 32, 6OX 25, 6BQ 20, 6DAU 20, 6DCT 9, 6CNK 8, 6SB 8, 6BFE 4, 6SJ 1.

NEVADA—SCM, C. B. Newcombe, 6UO—6BTJ worked V8G off the coast of Newfoundland on 80 meters. 6LB, the new station at Mt. Montgomery, is now a full-fledged ORS. He says his Xmitter is one mouse power but will have higher power soon. His daily reports on road conditions are greatly appreciated by the travelling public. This information is furnished to the Automobile Assn. of Nevada and also to the Auto Club of Southern Calif.

Traffic: 6ABM 83, 6BTJ 20, 6LB 4, 6UO 26.

SACRAMENTO VALLEY—SCM, C. F. Mason, 6CBS—Activities are picking up. A new relay station is coming on. The Radio Club is going strong.

Traffic: 6CDK 25, 6ER 23, 6GR 12, 6AYI 10.

ROANOKE DIVISION

VIRGINIA—SCM—J. F. Wohlford, 3CA. 3KU works on 20 and 40 meters mostly. 3WM worked sblAW. 3CKK reports trouble getting xmitter to work on proper waves. Don't let it flop over in the other fellow's territory, OM. 3SR says the 80-meter set is perking, and the 40-meter set under construction. 3NM also has QRM from school but expects to get on after Xmas. 3AG has too much school QRM for skeds but handles some traffic at other times and seems to QSO some excellent DX. 3HGS has gotten up to 80 meters and is perking along fine. 3KG drops in at 2BCS and helps out some. 3CEB, 3SR, 3CKL and 3BDZ visited the SCM on Thanksgiving Day. Sorry more of you could not get here. Come again fellows.

Traffic: 3KU 57; 3NM 1; 3AG 32; 3BGS 13; 3CA 72;

XIV

NORTH CAROLINA—SCM, R. S. Morris, 4JR—4EC is moving. 4VR has been appointed ORS. 4SJ is moving to the country. 4TS is building a 15 watt push-pull low impedance set. 4JR has at last struck a lucky combination with his crystal-oscillating amplifier. 4OH says YLs are R9. 4MI is giving crystal another try but is holding his MO-PA set in reserve. 4OC handled some New England flood traffic. 4PR and 4BX are QRW business. 4ADK is beginning to get out now. 4ADG is now in his new shack and going strong with two 201s. 4NH has rebuilt his set and is now using tube rectification throughout.

Traffic: 4VH 38, 4JR 24, 4MI 15, 4EC 8, 4OC 6, 4NH 4, 4SJ 3.

WEST VIRGINIA—SCM, C. S. Hoffman, Jr., 8BSU-8HD—The curtain seems to have gone up for the fall season, with the old spirit of activity in traffic. 8VZ had schedules with 9DTK and 8GI, handling 256 msgs. 8DCM has schedules with 2CXL, 2CDM and 8OXZ. 8CNZ had schedules with 1PE and 2LZ. 8DDN has schedules with 4ACT, 8DCM and 8OK are putting in new equipment. There has been a lot of activity in Wheeling with 8AUL, SADI, SBUB, 8BSU, 8DPO and 8BPA on. 8CV is QRW school. 8BUB uses 20, 40 and 80 bands. 8ADI handled a death message. 8DPO is putting in 2-852A. Glad to hear from 8CLQ. The SCM wishes to thank SAUL, 8BFB, 8ACZ for their special effort in broadcasting the A.R.R.L. msgs relative to the Conference and to 8AWM for his personal efforts. It is hoped that the future will bring in as good a number of reports and amounts of traffic handled as the past month.

Traffic: 8VZ 256, 8CNZ 79, 8ACZ 19, 8BUB 14, 8CLQ 13, 8DCM 10, 8DPO 7, 8AGI 2, 8BSU 2, 8DDN 1, 8ADI 1.

ROCKY MOUNTAIN DIVISION

COLORADO—SCM, C. A. Stedman, 9CAA—Traffic seems to be picking up in the state if the fellows only want it. The traffic men are handling them in gobs now while others that have less time are doing more DX than anything. 9EAM broke loose this month and put himself in the lead of the section as well as in the BPL. He adds that a higher total is due this coming month. FB, OM. 9CAA followed a close second but he couldn't quite make the grade. Schedules did the trick in both cases, as usual. 9CAA is using remote control and is working on an idea to control the transmitter byline fone from across town if he wants to. 9ENM at Pueblo is very active on 40 meters and says he will be on 80 soon. He has applied for ORS. The Associated Radio Operators of Denver held a joint meeting with the San Isabel Radio Assn. at Pueblo this month. The Denver gang certainly appreciate the courtesies shown, and the SCM wants to say that Pueblo is full of ham activity as well as other activity. 9CAT is on 40 and working out well. 9DRV and 9EEO are coming up. 9BYO and 9DGJ aren't doing much due to school QRM. 9CCM, the YL of Denver, is very active and can be heard most every night kidding the OMs along, but handling traffic, also. 9DQD at Grand Junction has applied for ORS and has a couple of skeds, also. 9EJW is on a transcontinental route. 9QL reports ND much. To the stations who are not reporting, this is a last warning. If you don't come thru, there is going to be some cancellations.

Traffic: 9EAM 200, 9CAA 185, 9ENM 18, 9BYC 4, 9DGJ 3, 9CCM 3, 9EJW 31.

UTAH-WYOMING—SCM, D. C. McRae, 6RM—This month has been one of the best we have had for some time and let's keep it growing, gang. With the Christmas season about on us, we should put thru a good traffic total for December. Several new stations have made application for ORS and will probably be going strong by the time this gets in print. 6AIK still continues to hold down the Ogden end of the game and has been doing some good work. 6DPJ and 6DPO, Provo, Utah, have both applied for ORS. FB, as we have needed some stations down that way for a long time. 6DBS has also made application for ORS. 6RV has set remote controlled now and reports it FB. 6BTX still continues regularly on the air and keeps skeds with 9ENM and operates 4 days a week with him. 6RUH manages to get on the air some

QST FOR JANUARY, 1928

and keeps things going altho he is tied up most of the time. 6CNX of Ephraim, Utah, came thru with a report for a change. FB, 7DA of Wyo. is still in Nebr. and at present, no reports are being received from active stations in Wyo. What's the matter, gank, let's see some reports from you. The SCM feels that it will be necessary for some one else to take over his job as he doesn't have time to do the thing right.

Traffic: 6CNX 59, 6AIK 10, 6DPJ 22, 6RV 24, 6BRAJ 40, 6BTX 64, 6CQL 2, 6RM 1, 6BUH 6, 6DBS 3.

SOUTHEASTERN DIVISION

FLORIDA—SCM, C. E. Ffoulkes, 4LK—The Convention will be held at the Alcazar Hotel, Jan. 13 and 14. I hope as many of you fellows as possible will attend as the Miami Radio Club is working hard to put this over in a big way so boost them all that you can. The SCM was very glad to welcome to our fair state this month, 2KH from N. Y. C. 4OY from Spartanburg, S. C. and 4EG from S. C. Traffic was not very heavy this month but Xmas should help things quite a bit. 4CK leads us again this month. He reports by WU. 4OO handled some flood traffic from Vermont. 4AAO says business cuts into his skeds and will have to QRT business. HI, 4RK has moved his shack. RL of 4LK has been QRW football. 4ACZ is an old ham with a new call. 4TR is on 20 and 80. 4RN has been testing with 4KY in regard to fading. 4MS's car got out of synchronism and jumped on him. That sure is too bad. OM, 4OB has an Aussie for breakfast every morning. 4HY says MO is sure fine business. My Bonnie Lies Over the Ocean as revised by 4TK—Bring Back, Oh, Bring Back My DX To Me. The SCM would appreciate hearing from any active non-ORS, so send in your reports, OMs.

Traffic: 4CK 31, 4OO 24, 4AAO 24, 4RK 16, 4LK 13, 4ACZ 12, 4TR 11, 4RN 10, 4MS 6, 4OB 4, 4HY 4, 4TK 4.

ALABAMA—SCM, A. D. Trum, 5AJP—A most pleasant visit from our Radio Inspector seemed to have stimulated interest and activity this month although very few reports reached the SCM's office. 5AYL has started quite a bit of enthusiasm in Huntsville on amateur radio by putting an 852 on the air with a chem rect. 5ABS reports a little slackness in his part but promises better next month. 5YB writes that the station has been having plenty of trouble with the note, however, its R8 sig can be heard most everywhere. Birmingham reports a new ham in 5AS who comes into the fold with a great big fifty and a good fist. Welcome, OM. Montgomery boasts of most consistent activity. 5JY is on practically all the time with a good note and fist and challenges all comers for traffic. 5ADA has put away his dynamotor and gone back to the old reliable chem. 5ATS, Montgomery's latest ham, boasts of fine DX, having worked OA and OZ with R5 report. Robert Troy, an amateur enthusiast of long standing, is now on at 5ATJ and with his trusty 7½ water, is doing nicely. 5AJP was on very little on account of pressing business.

Traffic: 5ATJ 2, 5ATS 9, 5ADA 8, 5JY 114, 5AS 9, 5YB 54, 5ABS 14, 5AYL 23, 5AJP 10.

GA.—S. C.—CUBA—SCM, H. L. Reid, 4KU—Georgia: 4GY is doing nice work but has been too busy this month to carry on. 4RN hasn't missed out on sked with sc-3AG since Aug. 4UO went to Birmingham Thanksgiving Day and visited a few of the 5's. South Carolina: 4KZ at Greenville, turns in the only report for this state this month.

Traffic: 4UO 20, 4RN 18, 4KZ 2.

WEST GULF DIVISION

NEW MEXICO—SCM, L. E. Radka, 5TT—Four stations reported this month and traffic is picking up. 5APB is troubled with a bad power leak but managed to be high man this month in traffic handling. He hopes to tear holes in the ether with a new 75 watter. 5TV is a new station at Des Moines and reports for the first time this month. FB, OM, as we need more stations to keep things moving in this section. 5BH is the second to receive an ORS certificate. 5RO has a schedule with 6ZD and is handling league traffic for him. A

schedule is also being arranged with 9EEA, 5TT and 5LG will have the college station on the air before the Christmas holidays.

Traffic: 5APB 17, 5TV 13, 5BH 12, 5RO 7.

SOUTHERN TEXAS—SCM, E. A. Sahn, 5YK—Activity does not seem to be as great as could be expected this time of the year or at least the reports do not show it. 5ALA has changed his QRA back to Miranda and says that he will be going full blast at that place in a few weeks. 5AHP turns in a good report as usual. 5MS has shipped out to sea for the winter and hopes to be on again in a few months. Our proximity to the Gulf causes a large number of our hams to become commercial ops. But they always remain faithful amateurs. 5PK is another one of our boys that has gone to sea. He will be on the Bessemer City, taking a trip around the world. 5EW will report what 5PK is doing from time to time. FB, OMs. 5RR also writes that he is shipping out to Mexican ports. 5EW has had trouble getting equipment for his set after burning some of it but he will be on strong again in a few weeks. The Rexar County Radio Club is rigging up a transmitter. They have it almost completed. This report was sent in by Fred Kush, the President.

Traffic: 5ALA 6, 5AHP 7.

OKLAHOMA—SCM, K. W. Ehret, 5APG—The West Gulf Division is at last to have a Convention of its own. On Feb. 10 and 11th, the first West Gulf Div. Convention will be held with a full program of lectures, prize contests, discussions and stunts. Plan to be there, fellows. Any information regarding this may be obtained by addressing the Convention Committee in care of your Section Communications Manager, who will see that your inquiry reaches the Committee promptly. Traffic interest is picking up with the return of 5AMO, 5FJ and 5ADE. A piece of glass the size of a quarter jumped out of 5DQ's 50-watter and he is too sick to report. 5ADO has never been right since he returned from Borzer. 5ANL has rebuilt his xmmitter commercial style using two 7½ watters and is keeping most of his schedules in fine style. 5ABO still working 180-meter fone and keeping skeds with 5ARX and 9BZL. 5VH keeps skeds with 6FJ and 5ANT and expects to have competition from a new ham soon. 5AIR reports tlc total coming up keeping skeds with 5FJ, 5ABQ and 5NC. 5ARX is back on the air and 5AXG has increased his power. 5FJ is going strong on traffic, operating every afternoon and keeping skeds with 5ANT, 5OD, 5AMD, 5AIR and 5OH. 5ANT is doing his stuff on skeds and also DX. 5AKA has been messing with BCL sets in Tulsa but promises to come home like a good boy and pound brass again. 5QL has at last become infected with the crystalitis germ and handled some traffic when it was pushed on him. 5SW works periodically. 5AYO is a new addition to the traffic gang this month. 5ADE reports considerable operation during day time and reflects in his message report. 5ADE has been having tough luck but we hope he will be back on the air soon with a free mind. 5AAV has been collecting quartz specimens and 5APG.

Traffic: 5APG 9, 5ANL 20, 5AOB 12, 5FJ 178, 5AIR 26, 5AMO 6, 5VH 28, 5ANT 66, 5AYO 7, 5QL 15, 5SW 6, 5ADE 168.

CANADA

MARITIME DIVISION

PRINCE EDWARD ISLAND—SCM, F. W. Hyndman, 1BZ—1AP has changed his QRA to Summerside, P.E.I. 1AA in Charlottetown is on the air again now. 1BZ will be active during December. 1CO is moving to the third district.

Traffic: 1AP 31, 1CO 17.

NEW BRUNSWICK—SCM, T. B. Lacey, 1EI—There has been considerable stir in amateur activities in this province the past month. Many stations which were more or less idle during the summer months are blossoming out again. Reception is improving and all looks well for a busy winter season. The first radio show to be held in New Brunswick was held in St. John on Nov. 27, 28, and 29 and a short-wave transmitter and receiver were installed and considerable traffic handled. There are three new amateur licenses issued for

stations in St. John but all are now building and not on the air yet. 1AD has just got back from New York and Montreal—we learn that his financial wave was absorbed by some friendly DX hound and he returned on low power. 1EI has moved in from the bush to St. John city and is erecting a new antenna system and hopes to be on the air soon. 1CB says his sigs don't seem to get out of his back yard and finds it hard to QSO anybody, even locals. He is putting in some new additional equipment in hopes that he will be able to get out better. 1AK is on every day and has handled quite a number of messages this month and has been QSO a few foreigners on 40. 1AX had a lot of schedules this month but didn't finish them up on account of blowing his tube while working ne-1AM who pretty near lives next door. Hi.

Traffic: 1AX 42, 1AK 40.

QUEBEC DIVISION

QUEBEC—SCM, Alex Reid, 2BE—There have been more stations on in this division than ever before and it is very encouraging to see the boys showing such pep; there are a number of skeds being kept and traffic totals are jumping. 2BR and 2BB are our star stations in this line.

Constable Timbury, n5AO, of the R.C.M.P. who was stationed in the Arctic for two years, is visiting in Montreal. He says 2BE's sigs were R6-8 nearly every night last winter. 2HT is on the air again with a beautiful new transmitter, it is the best job we ever looked at; he can QSY to all wavebands and also use fone on 175. 2BG, 2CW and 2BE from the South Shore are on every night. 2AL, 2CG and 2AX are doing a good job in Montreal. 2BR, 2BB and 2DO are sure keeping things going on the Lakeshore. In fact, the Lakeshore gang are the real traffic men. 2AL and 2BE did good working during the Vermont flood.

Traffic: 2BR 43, 2BB 42, 2BG 8, 2AL 9, 2BE 6, 2CW 5.

ONTARIO DIVISION

ONTARIO—SCM, W. Y. Sloan, 9BJ—There is a slight increase in activity, especially on 52.5 meters on Prayer Meeting nights. Central Dist: 3CJ has been forced to keep rather late hours lately owing to the ardent activities of his BCL friend, but he has managed to do some wonderful work with his fiver, having worked all U. S. districts. 3ED, the station of the Toronto Central Tech. School, is on the air again and operates regularly during Noon hours from 12 to 1 o'clock daily on 40 meters. 3BK has been on the air regularly keeping a schedule with 2BR at Montreal. 3AZ keeps a sked with 4FV at Winnipeg on 52.5 meters. 9BJ has been in active operation this month mainly on 52.5 meters where the station gets out in fine shape. A schedule is being kept with 2AL in Montreal on that wavelength. 9AL is heard pounding away on 42.5 meters crystal-controlled and also on 40 and 80. 3FC has done very little in the way of operation as he gets enough brass-pounding at 9AL. 3DB has been on occasionally, mostly weekends. 3CW has been playing with antennas and has decided that he prefers the antenna and counterpoise. 3FQ reports that he is beginning to reach out using 2 201A tubes on 80 meters. Keep at it, OM. 3EG is also on the air on 40 meters and is looking for contacts. 3DV has rebuilt and is getting good results on 40 meters. Southern Dist: 3CS has a new third harmonic antenna, and is very pleased with it, having worked much good DX since its erection. 3IA has completed his rebuilding program and is all set now for some DX. 3CB has been trying to persuade his set to work on 52.5 and is staying with it until it does. 3FU and 3DU have left the district.

Eastern Dist: 3MP is our only reporting station in the East and he is doing very fine work on 20 meters. He is also interested in 52.5 meters and says that he will be on regularly on that wave.

Northern Dist: 3HP has been active as usual on 20, 40 and 52.5. He says that of late, DX has been very good and he has been getting many English reports.

Traffic: 9AL 27, 3CJ 22, 3CS 26, 9BJ 20, 3DY 19, 3FC 17, 3BK 14, 3HP 24, 3AZ 6, 3CB 6, 3BL 5, 3GN 4, 3DC 3, 3RT 2, 3DV 1, 3EL 1.

XVI

YANALTA DIVISION

BBRITISH COLUMBIA—SCM, E. S. Brooks, 5BJ—5AL takes the cake this month with a traffic total of 46, all done on 80. He keeps two skeds and uses an ancient VT2. 5GO has been appointed OBS for this section and will broadcast on 40.2 until further notice. 5BR has quit 40 and is now using 80 exclusively. 5CT tries all bands and keeps skeds with 5AL on 80. He worked 1AP on 52. 5DN sends in a good report and more is to be heard from him this winter. 9AJ is making improvements around the shack.

Traffic: 5AL 46, 5GO 20, 5BR 12, 5DN 9, 5CT 8.

ALBERTA—SCM, A. H. Amussen, 4GT—Three newcomers were successful with their exams in Calgary and will be on soon. 4CC is on consistently despite the YL QRM. 4IO is on 20 with a quart bottle. 4BZ has a new outfit with more power. 4GL is doing nice work and may be our best traffic station. 4JJ is contemplating a big JUG, more power to you, OM. 4AL has moved his xmitter to the University. 4HA has a 70-foot stick up and now gets R9 reports. 4CU also put up a big stick and says there is nothing like it. 4FF has a new antenna system and gets FB reports. 4AH has a new outfit and gets out FB now. 4CL is QRW. The R. L. at Calgary may be on soon. 4BV gets out with 45 volts on the plate. 4BC is on 20. 4GT only on weekends but works good DX with his hay-wire antenna.

Traffic: 4AF 9, 4GL 7, 4HA 2, 4FF 2, 4GT 5.

PRAIRIE DIVISION

SASKATCHEWAN—SCM, W. J. Pickering, 4FC—R. Fischman at Bateman is now working a d.c. fed 210 on 40 meters under the call of 4IH. 4CB reports rotten wx on 52.5. 4FC has put in remote control on his transmitter thereby saving on coal-oil consumption. 4CP is still going strong on 20 meters. 4HS is getting out good on both 20 and 40, and has 2000 volts on his UX-862. 4IH, 4AQ and 4HS had great rag-chewing party at 4HS shack in Oct. 4GB has been QRW selling sets but is always on Wed. nights on 52.5 meters. 4AS is kicking out FB and 4AO is so busy trying to find a good QRA, he can't get on as he would like to.

Traffic: 4HS 25, 4CP 7, 4CB 4, 4FC 4.

MANITOBA—SCM, Acting, D. B. Sinclair, 4FV—DX seems to be the most important activity in the province lately. 4DU's 250 is perking FB. 4DW was QSO WNP and nr-C70, 4BP and 4CT are new hams and get out well. 4EH has rebuilt and runs his set by remote control. 4DP also runs his set by remote control and has worked WNP and nz-E75. 4EK has moved and seems to get out much better. 4DY is on again, though on the road much of the time. 4FT says too QRW to start up again. 4FZ is married. Another good ham gone wrong. Hi, Congrats and best wishes from the gang, OM. 4FS, 4AR and 4DB are new hams outside Winnipeg. Get in touch with the SCM, OMs and let us have the dope. 4FV's 210 is still bearing up bravely having been QSO 26 countries since last April. 4CH is on again with a TP-TG which will not perk, as yet. Several new hams are only awaiting their calls to get going with a bang. 4DP and 4FV handled traffic with WNP, VDE, KFLF, VOQ, ss2BN and other expeditions. 4BT is away at Shattuck School at present learning to be a hard-boiled top-sergeant. Hi.

Traffic: 4EY 8, 4EK 3, 4BP 2, 4CT 7, 4FV 3.

The first licensed station in Japan is ajJXAX, which uses 10 watts antenna input on 38 meters. Mr. Kasahara, who sends this information, tells us that up to the time JXAX was licensed, all amateur calls in Japan were boot-leg. He also says that JLZR and JMPB are the calls of the Inspector's watch outfit, and is not a true amateur station.

By radio from 1FW and 1BDI come the news that "BX" of Mexico fame has been in Bridgeport, Conn., for some time, using the call 1BK. At the present time he is on a tour to Florida, carrying a portable outfit under the call 1ZZA. Daily at 5 and 10 PM EST, he sends a TR (position report) back to Bridgeport. He uses the upper end of the forty meter band.

QST FOR JANUARY, 1928