

# Hobbies

## WEEKLY

June 21st. 1944

Price Twopence

Vol. 98. No. 2540

## You can fit a clockwork motor to this MODEL TRACTOR

**T**HE tractor is now a commonplace object of both town and country roads and fields for agriculture and industry. Such a tractor would make an excellent working model, and we give here, an ordinary type of machine with a Meccano motor.

Even without the motive power added the model would make a most interesting piece to make. The motor is enclosed in a casing which makes for a neat appearance. There is also a steering arrangement which can be set as desired.

The Floor is a piece of  $\frac{1}{2}$ in. thick wood measuring  $8\frac{3}{4}$ ins. long by 2ins. wide. From the rear end of this piece cut a recess 2ins. long by  $\frac{1}{2}$ in. deep to allow for the driving pulley fixed to the back axle (see Fig. 1).

### Steering Arrangement

On each edge of the floor piece is fixed a side section which is shown in Fig. 2 ready for drawing out full-size. After lining this out on to  $\frac{1}{4}$ in. wood cut it out and include on one piece only the two holes as shown.

At the rear of the motor and flush with the recess in the floor a block of  $\frac{3}{8}$ in. thick wood is glued and screwed to the latter. This is to take the pillar of the steering wheel (see Figs. 1 and 3).

The latter figure, incidentally, gives the position of nearly all the parts which go to make up the model and the scale shown beneath the detail will be helpful to the builder for measuring off certain parts or positions.

Before fixing the motor to the floor see a small pulley wheel is fixed to the power spindle ready for linking up with the driving belt after the larger wood pulley is in place.

The front measures 4ins. by  $2\frac{1}{2}$ ins. by  $\frac{1}{4}$ in. thick and covers the whole front including the floor edge and the edges of the sides and the top.

### The Top

In the smaller diagram at the top of Fig. 1 is shown the top of the casing. This top piece might well be screwed

in place to facilitate removal in case of the possibility of adjustments to the motor.

### Back Axle

The back driving axle is  $4\frac{1}{2}$ ins. long and consists of  $\frac{1}{4}$ in. round rod. At a distance of  $1\frac{1}{4}$ ins. from one end of the axle glue a wooden pulley about 2ins. diameter with the groove cut in deep enough to make a sound grip on the driving belt, see Figs. 1 and 3.

Each of the large wheels is made from three parts—one plain  $\frac{1}{4}$ in.

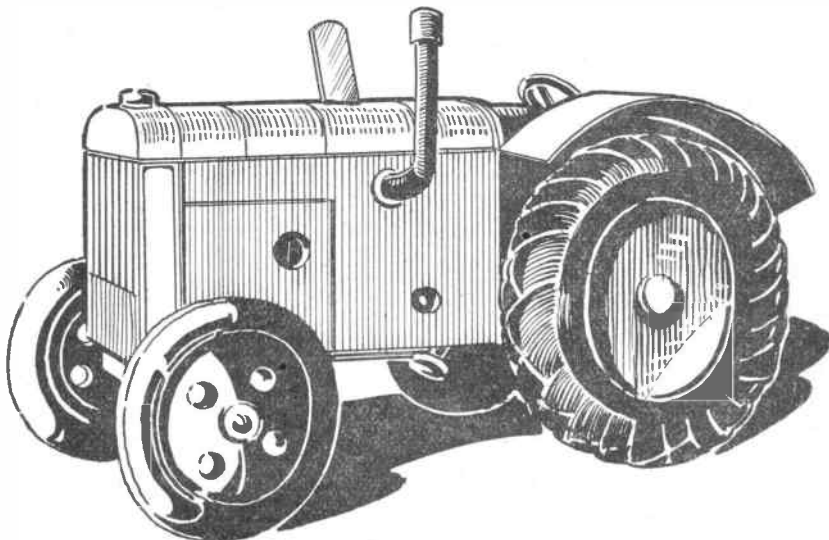

Can be made as a plain model or with clockwork drive

thick disc  $4\frac{1}{2}$  ins. in diameter and two rings of  $\frac{3}{8}$  in. wood glued on either side. The latter are shaped with the rasp and file to the section shown in Fig. 4.

A plain capping disc about  $\frac{3}{8}$  in. diam. and  $\frac{1}{4}$  in. thick is glued on the outside face of the wheel. On the inside face a  $\frac{1}{2}$  in. washer or disc  $1\frac{1}{2}$  in. in diameter is glued to make a substantial hub for gluing to the axle.

The mudguards are made from tin cut from a container and afterwards painted. Two strips of the metal

runs back to the projecting lower end of the steering pillar (Fig. 3). Thus by turning the wheel the cord is unwound on the one side and tightened up automatically on the other side.

### Wheels and Tyres

Front wheels are made in a somewhat similar way to the rear wheels. The plain centre disc here is  $2\frac{3}{8}$  ins. diameter and  $\frac{1}{4}$  in. thick and on this again are glued an outer and an

further down the washer C is glued on to keep the steering cord in its proper place. The steering wheel is  $1\frac{1}{2}$  ins. in diameter and cut from  $3/16$  in. stuff.

The two parts required for the seat are shown in Fig. 7. The shaped support is cut from  $\frac{1}{2}$  in. wood and the wide end bevel glued to the floor block (see Fig. 1).

The seat itself consists of a piece of wood about  $1\frac{1}{2}$  ins. long by 1 in. rounded on two corners and with

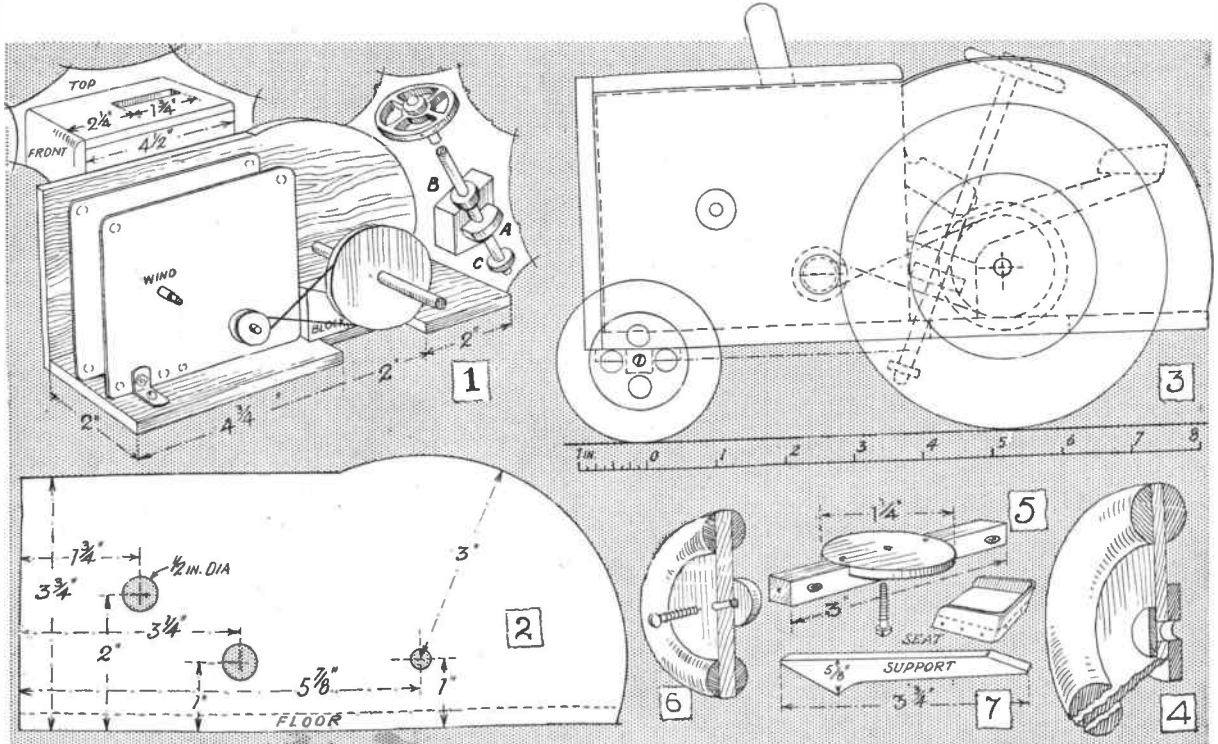

will be required 5 ins. long and  $1\frac{1}{2}$  ins. wide. They are shaped round the circular portion of the sides of the casing as seen in the double line at that part in Fig. 3.

The metal should be punched with small holes  $\frac{1}{8}$  in. from the inside edge of the mudguard and about  $\frac{3}{8}$  in. apart and pinned to the wood with  $\frac{1}{4}$  in. brass fret pins.

### Front Axle

There could hardly be a simpler method of forming the front axle than that shown in Fig. 5. A piece of wood 3 ins. long and  $\frac{3}{8}$  in. square is required. Centrally on one side of it is a  $\frac{1}{8}$  in. deep recess into which is glued and screwed a circular disc  $1\frac{1}{2}$  ins. in diameter.

A hole is bored through the two pieces of wood centrally to take a  $\frac{3}{8}$  in. roundhead screw which must pass freely through the hole to allow the axle to revolve easily.

Near the ends of the axle are two eyes intended to take the cord for steering the tractor. A length of this cord is tied to the eyes and then

inner ring of wood  $\frac{1}{8}$  in. thick and  $\frac{1}{8}$  in. wide.

The shaping to represent the tyres is carried out similarly to the large back wheels. A  $\frac{1}{4}$  in. washer  $\frac{3}{8}$  in. diameter is glued to the back of each wheel to form a hub sufficient for holding the wheels true (see Fig. 6)

The steering wheel fixing needs but little explaining as the detail on the right in Fig. 1 clearly shows all the working parts. To the shaped block on the floor of the tractor is glued the guide A through which the steering pillar passes.

To keep this in its proper place a washer B is glued to it which rests upon the sloping surface of the block but at the same time allowing the pillar to turn freely.

The pillar again passes through a sloping hole made in the floor and

a piece of tin bent round and tucked on as shown. The front edge of the seat should be rounded off.

A rather important addition must be made in the way of an efficient "stop" for the front axle. The axle, complete with wheels of course, must be turned fully to right and to left and a mark made in pencil on the floor just where the axle crosses before the tyres of the wheel touch the wood on either side.

Drive in a couple of small screws or nails on the line to prevent the axle from turning beyond the limit line.

### Colouring the Work

The woodwork of the tractor, after a final clean-up, should be painted in bright colours, two coats being given to get a brilliant effect. The tyres should be painted light grey with the wheel centres yellow.

The exhaust pipe on one side of the engine casing, seen in the sketch of the tractor, may be represented if desired by a piece of bent tubing, or even by a piece of round rod shaped and painted.

### NOTE

Pattern Sheets are not given away with back numbers, but are then obtainable for 4d. each (postage 1d.)



# Here is something quite novel and yet practical— A GAS-LIGHTER GUN

A NOVEL, original, spring-action type of gas-lighter gun is shown at Fig. 1. The primitive, but effective mechanism consists of a flint wheel spindle having a crank and a thumb lever, with a spring attached to the crank. By turning the lever (with the thumb of the hand holding the gun) in a clockwise direction as far as it will go, the spring is tightened, the tension jerking the crank down to its original position as soon as the lever is released.

It is inadvisable to solder the flint wheel to the spindle, because when the employed half of the wheel becomes dull and useless after a long period in use, one cannot bring the unused half into operation. One can do so if the wheel is merely affixed to the spindle with suitable nuts, these being "locked" against the wheel.

Undoubtedly, the spring-action

## The Gun Shape

Cut the gun shape from wood to the outline plotted in  $\frac{1}{2}$  in. squares (Fig. 2) with an ordinary fretsaw. Cut around the outline shape only. The crank spring aperture is not cut out until a groove has been made along the top for a strengthening rib of wood, as shown.

The width of the groove (and rib) is made to suit the thickness of the wheel spoke—roughly  $\frac{3}{32}$  in. thick. A tenon saw will cut a suitable groove, but if the kerf proves to be too fine, a panel saw, or rip saw, will produce the width of groove required.

As shown by the dotted lines in the outlined shape, the depth of the groove is  $\frac{3}{8}$  in.

A hole is drilled through the nose end of the gun shape to take the flint tube, as can be seen at Figs. 2 and 3. Another hole is bored through the side so it "breaks" into the flint tube hole slightly. This additional hole is for a wedge-shaped peg of wood which, when the tube is fitted, is tapped home to "lock" the tube firmly in position (see inset detail).

## Flint Wheel Spindle

An exposed side view of the gun is shown at Fig. 3 to show the working principle, while the size and shape of the flint wheel spindle appears below the diagram. Bicycle wheel spokes can be bent without heating, but sharp bends or corners are impossible unless the metal temper is softened. It is thus possible to bend the spoke into a suitable spindle shape while in the hard-tempered state, using pliers. Be wise and bend the wire to shape before fixing on the flint wheel, i.e., in case the wire should snap.

When forming the crank in the spindle, try to get the length shape truly in alignment so it will turn truly when fitted in its groove. Incidentally, a  $\frac{3}{8}$  in. deep crank (to give a  $\frac{3}{8}$  in. stroke) could be bent, this giving more room for a longer spring.

## Fitting the Flint Wheel

A  $\frac{3}{8}$  in. diam. flint wheel is better than a  $\frac{1}{2}$  in. diam. one. It gives a bigger "kick" than the latter, and furthermore, the spindle hole will be more suitable for the threaded end of a bicycle spoke.

To attach the wheel to the spindle, screw on a nut, slip on the wheel, add the second nut, both being forced tightly against the wheel and thus

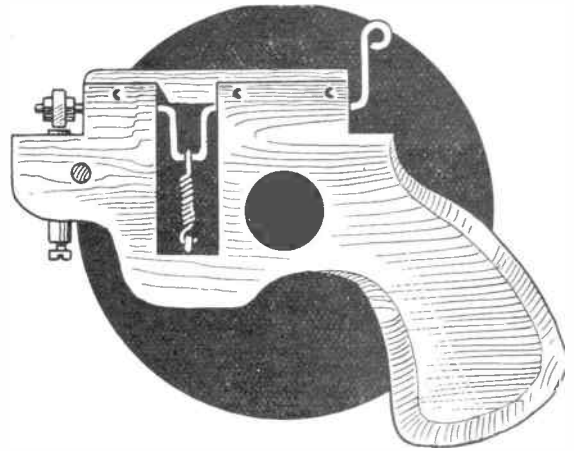

Fig. 1—Simple spring-action gun for gas lighting

effectively locking it on the wire. Should the spindle hole in the wheel be too small, there is no alternative but to force it on the spindle as a permanent fixture.

Whilst fitting the flint wheel, be careful to see that the "teeth" are turned in the correct direction. When the spindle is turned in a clockwise direction by the thumb, the teeth of the wheel should not "cut" into the flint.

Having fitted the wheel to the spindle, the latter is set in the groove and the rib piece glued down on top of it, as shown. The flint tube is inserted in its hole to project suitably against the bottom edge of the wheel, following which it is wedged in position.

(Continued foot of next page)

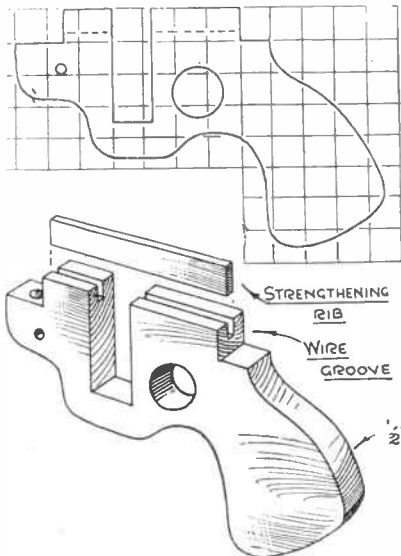

Fig. 2—Shape in  $\frac{1}{2}$  in. squares, with constructional details

type of gun is better, in a way, than any direct-operated, continuous, thumb-action type having a milled knob instead of a wire lever (the latest design of utility gas-lighter, incidentally, is an example), because it is not every one who can flick the knob quickly with the thumb to turn the flint wheel spindle rod.

To make the new type, of course, certain petrol lighter parts are required. These comprise a  $\frac{3}{8}$  in. flint wheel, flint tube, with spring and screw adjustment, plus an old bicycle wheel spoke, a screw-eye, an elongated spring and a piece of wood  $\frac{6}{16}$  in. by  $\frac{1}{4}$  in.

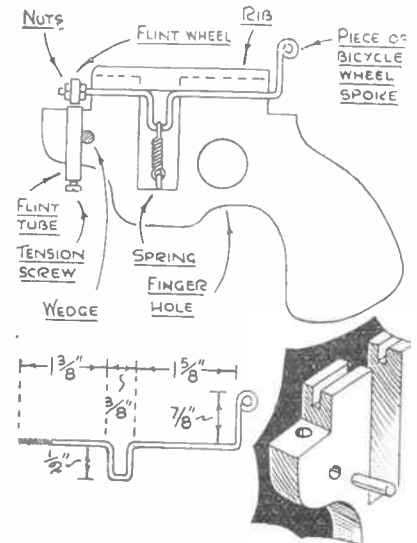

Fig. 3—Side view and details of flint crank

# Patterns provided on Cover iii for cutting out this SIMPLE CLOCK CASE

WE are giving this week a design for a clock case, simple in outline and dignified in appearance. Such a useful article as this should be popular with fretworkers who do not care for too much intricate cutting.

On Cover iii in this issue we have been able to include the full-size patterns for this clock case, and so help the worker materially as he will have no drawing out or enlarging to do at all. A general impression of the finished case is gained from the sketch on this page.

## Suitable Movement

The clock movement suggested has an ordinary nickel-rimmed surround about 2½ ins. diameter and a

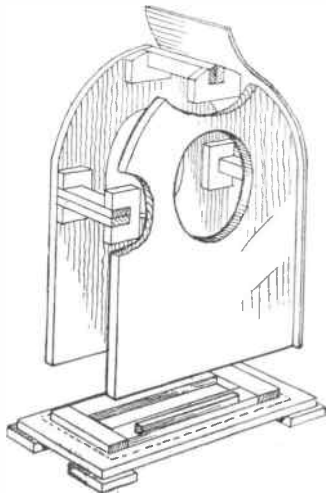

Fig. 1—A helpful constructional detail

drum about 2½ ins. Any movement round about this size can be adapted, the circle for the drum being struck from the centre given, by compasses spaced to the required radius.

As will be seen from the patterns the front and back of the case are identical in size and shape and both

are cut from 3/16 in. wood. These two pieces are held apart by the distance pieces marked A and B on the sheet.

It will be noted that there are two thicknesses of A cut and glued together, the top edges being chamfered to the same curve as the front and back of the case. Before these distance pieces are glued in, however, the flat fixing pieces must be cut, fitted and glued to the ends of them.

## Stiffening Parts

These fixing pieces are necessary for giving strength to the case as it is well-known that glue has little holding power to end-grain wood. Therefore the three units can be made up complete and afterwards inserted between the front and back sections exactly as seen in Fig. 1. It will be seen that parts of the front in Fig. 1 have been cut away to show the interior.

The case should be held rigidly together at its lower extremity by forming a simple frame of some cheaper wood perhaps. This frame is seen in Fig. 1 glued to the main base and ready for the case to be glued down over it.

Some plain fixing fillets may be added inside the case if desired as additional strength. The cross-section of the wood used for the inside frame mentioned above is ¼ in. by 3/16 in.

## The Base

The plan of the main base is given in the patterns. This piece must be carefully squared up and tested with either a set square or a try square. When the base is on, and glued and screwed securely to the inside frame the whole should be ready to receive the sides.

Two strips of thin veneer wood or ply-wood are suggested for the sides. Each piece should be 8 ins. long and from 1½ ins. to 2 ins. wide, this allows for an overlap beyond the face of the front and back as shown in Fig. 1.

After the fixing and gluing has

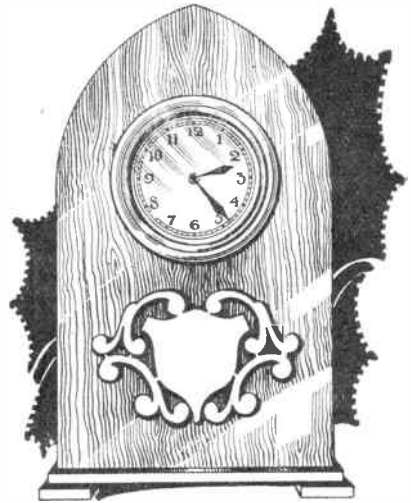

been done and the glue has thoroughly hardened, this waste margin of thin wood can be cleaned off easily and the whole face made neat and even by glasspapering. The two thin layers should meet neatly along the ridge piece A.

To facilitate the gluing of the sides and to hold them tightly to the case framing while the glue is hardening, stout cord should be tied round and wedged up and held thus until a sound and strong joint results.

## Feet and Decoration

Four feet for gluing on to the base can be cut from the waste wood of the front as shown. An attractive little overlay to be added to the front of the case is given full-size on Cover iv. This should be cut from thin wood and carefully glued on, one or two small fret pins being added in certain places to hold it well down.

Before this overlay is added, however, that is if a stained or polished effect is going to be given to the case, this work should be done while the front is clear so that a broad surface is available.

## Lighter Gun—(continued from previous page)

The spring actuating the spindle crank should not be too strong. For example, a short piece of spring curtain rod (expanding rod, as it is known) would be too powerful. A spring resembling it is wanted, but more yielding.

If a spring cannot be found, the next best thing is elastic power, using several elastic bands. If such has to be incorporated, drive an "opened" screw-eye into the base of the spring aperture. Get (say) two

lin. diam. elastic bands and, fitting the ends into the hook, bring the remainder over the spindle crank and down to the hook. This ought to provide sufficient tension.

To give a more comfortable "feel" to the gun, the stock, or grip, could be rounded over at the edges as suggested in the drawing at Fig. 1. The chamfering is easily done with a penknife, rasp, file and glasspaper.

For a finish, a single coat of polish would suffice, any colour being

suitable. Enamel paint could be used, apply a single coat. Clear varnish, over a stained surface, is another simple finish.

If, when testing the gun, the wheel sticks, remember that this happens practically every time with ordinary lighters worked by a flint wheel. Slacken the new flint in its tubing and try again. Sparks may be weak, but once the wheel has worn a shape for itself on the tip of the flint, the flint spring can be tightened up properly.

# There should be no trouble in making this useful SET OF TABLE MATS

THESE useful articles serve equally well for home use or as a welcome present. They are easily made and cost little when made of cardboard. A suggestion for a stand is given which serves to hold them tidily, but the stand is entirely optional.

Two or three layers of cardboard are necessary, according to the thickness. That which grocers receive their supplies in is about the most suitable, as its substance is good and its colour a lightish brown, pleasing to the eye.

The shape shown, octagon, is a convenient one and the sizes given about standard. Some time will be saved by first making a shape, or template, from which the mats can be copied.

## Making an Octagon

A piece of thin cardboard, or stout cartridge paper, will do for the template. On this describe an octagon as in Fig. 1. It is quite simple, as many readers know; to those who do not, first draw a square to size given.

Centre it by diagonal lines and with a radius of corner of square to centre, strike the four quadrants shown, one from each corner. Where these touch the sides of the square connect by straight lines to make the octagonal shape. From the centre again, strike a circle  $2\frac{1}{2}$  ins. radius.

Divide this into 24 equal parts 15 degrees each part (a protractor will be helpful here) and make a dot

on each part. Then cut the octagon out.

Lay this on the cardboard and mark the shape by running a pencil round the outline, and without shifting the template, press the awl through each part on the circle, thus making a ring of 24 small holes. Cut the cardboard to shape. Six of these can be prepared.

## Suitable Cardboard

Now cut out, on the full side, 12 squares of cardboard, 6 ins. each way. Any of the cardboard which had printing on it, and most grocers boxes have some, should be saved for the middle pieces of the mats if three layers to each mat are necessary, or alternatively use printed side inwards.

Take one shape, lay it on two cardboard squares and fix the three together with a pair of drawing pins to a piece of board. Then, with an awl and with the points on the ring as guides, pierce a ring of holes through all three for sewing.

## Sewing the Shapes

For this sewing job, coloured or black crochet cotton could be used, or anything of a similar nature. Proceed as in Fig. 2, threading the cotton in and out of the holes, as at A, then, when the ring is finished, continue the stitching backwards, as at B.

Draw the end through and tie both ends together underneath. This job done, lay the mat on a board and trim the cardboard squares to the octagonal top shape.

Finish off by blackening the cut edges with ink, or stain, or staining them any colour available as desired. Two larger mats are usually included in a set, for vegetable dishes and such like, one 6 ins. by 9 ins. and one 7 ins. by 10 ins. The original template can be used for the 6 in. by 9 in. one by using the following method.

Cut the cardboard to correct size, then lay the template, in turn, at each end to get the octagonal end shape and the half circles. Connect these half circles together by straight lines and punch the extra holes on these lines about  $\frac{1}{2}$  in. apart.

For the 7 in. by 10 in. mat it will be better to make a 7 in. square into an octagon and treat the mat with this similarly.

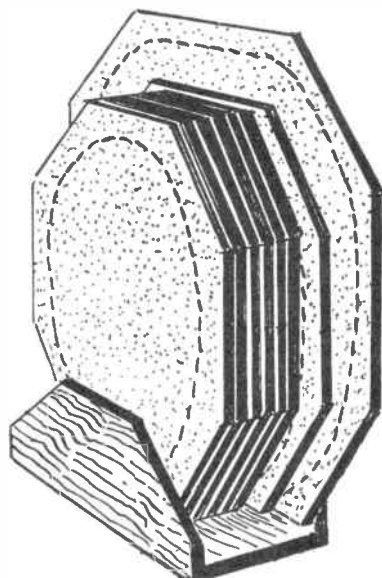

## The Holder

The stand can be made of fretwood. Mark out and cut an octagonal piece, as in Fig. 3, then saw it into two pieces across on the dotted line. The base piece, shown below the octagon, can also be of fretwood, or could be cut from deal,  $\frac{3}{8}$  in. thick.

Glue and nail together, as in Fig. 3, stain the edges to match those of the mats, and polish or varnish the wood.

In gluing the parts make sure to get the front and back upright and parallel. You can also add a narrow piece across each end which will further strengthen the whole thing

## SCALE MODEL LIGHTNING

This realistic scale non-flying model of the Lockheed Lightning in wood can be built from full size patterns on sheet No. 2540 presented with this issue. The necessary wood is sold by Hobbies Branches for 1/5 or sent post free from Hobbies Ltd., Dereham, Norfolk for 2/-.

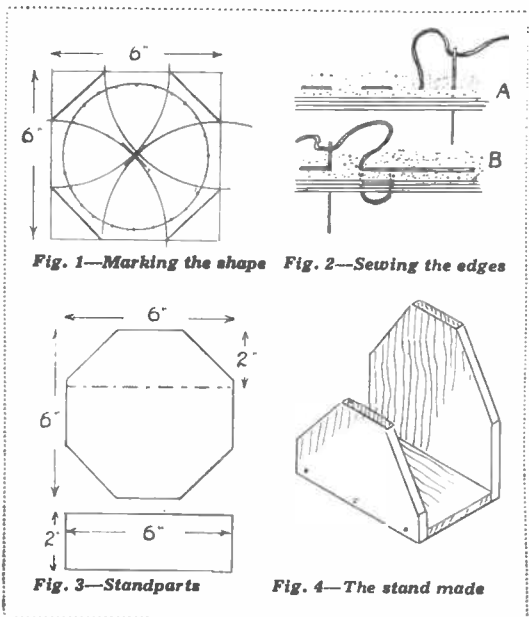
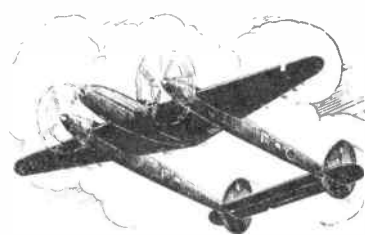





## AMERICAN MIDDLE ISSUE

(Continued)

**I**N our issue dated May 24th, we commenced an article on the fascination of some of the American Middle Issue low values, and explained differences in "National" and "Continental" printing. Now we can continue.

The "American" 1c. is blue, not ultramarine, and is rich and deep. It is unsafe to identify the "American" 1c. by paper alone, because the "Continental" 1c. is found on a soft porous paper as well.

Colour is a better guide, the "Continental" soft paper stamps being either a pale grey-blue or a pale greenish-blue in colour. There is also a greenish-blue in the "American" issue, but the colour is deeper than in the "Continental."

There is a small coloured crescent in the ball of the top left corner scroll and the background is heavily lined, showing most clearly at the top of the stamp and giving it a "square-cut" look in contrast to the earlier issues (see Fig. 7).

One would think it easy to "place" this stamp but it is astonishing how frequently it is classed with the "American" printing.

The 2c. of the "National" and "Continental" printings bearing a portrait of Andrew Jackson, are red-brown or brown in colour. The first is lighter than the second, with a marked chestnut tinge. The "Continental" inclines to brown and sometimes almost to black-brown.

Again, the colour is the safest guide in identification, because the

was changed to vermilion (bright orange-red). The paper was the thin hard paper of the 1873 issue. The "American" 2c. is also vermilion, but the colour is duller and flatter, and the head has not the sharp clarity of the 1875 issue. There was no 2c. in the 1881-82 "re-engraved" issue.

### A Speciality

The 3c. "Washington" is a most interesting stamp, so much so that some people have made specialised collections of this stamp alone.

The colour is green, with shades of blue or yellow-green, varying from pale to deep. The "Continental" 3c. can be distinguished from the "National" by a thick curved stroke



Fig. 5—(a) National (b) Continental 1c.



Fig. 6—(a) National (b) Continental 3c.



Fig. 7—(a) and (b) re-engraved 1c.



Fig. 8—(a) and re-engraved (b)

of shading immediately below the tail of the right ribbon under the "RE" of "THREE" (see Fig. 6b).

The "American" printing can almost always be differentiated by the paper, while the "re-engraved" is not only a more decided bluish-green in colour, but the shading below the central oval—especially on the right—is heavily reduced, leaving just a thin uniform and around the oval (see Fig. 8).

Much more might be said about these fascinating stamps—about the "Special Prints," about cancellations and rare varieties and so forth—but if what has been already said has whetted your appetite you can find out more for yourself.

### A word of Caution

One word of caution, however. If you decide to make as large a collection as you can of these stamps—and it is well within reach of anybody's pocket—try to get them as well centred as possible and do not buy damaged copies.

Those on the thin hard paper easily crack and split and those on the soft porous are very easily thinned, especially if old mounts are torn off instead of being soaked off.

With a little knowledge, with keenness and an observant eye, you can quickly make a very presentable and attractive collection of these three common stamps. And incidentally get your first introduction to a real philatelic training.

This is perhaps the hardest of all the 1c.'s to identify. The "Re-engraved" 1c. is a grey-blue with an almost chalky look. Apart from its distinctive colour, there are two other differences between the 1881-82 1c. and the others.

so-called "secret mark" of the Continental issue—a diagonal stroke under the ball of the scroll under "U.S." (see Fig. 5b)—often does not show at all.

In 1875, in a subsidiary issue of two values, the colour of the 2c.

## A Model for War Charity

**W**E have mentioned before the activities of the Hobbies Club of A. Schrader's Son of Birmingham, and of the splendid sums they have raised for various war charities. They have now given £480 in 18 months—largely from raffles for models made from our designs.

The picture is of our Doll's House (No. 227 Sp.) which was completed for this purpose

for the Lord Mayor of Birmingham's War Relief Fund.

The model house was completely furnished, fitted with electric light and oak panelled inside.

In addition to this, a model of the Old Country Inn which we published some years ago was made, completely furnished with wine bars and oak panelled rooms. It raised £69 in a similar effort.



# CLOCK CASE PATTERNS

see page 92

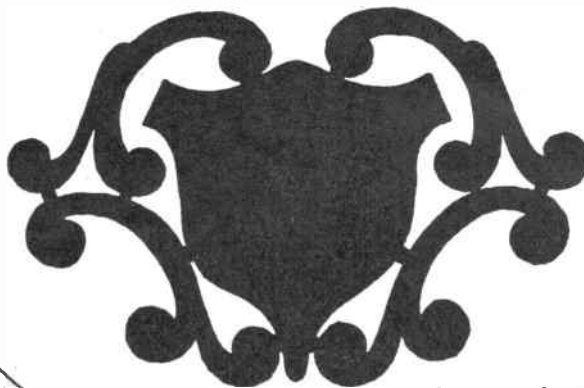

OVERLAY, CUT FROM THIN WOOD.

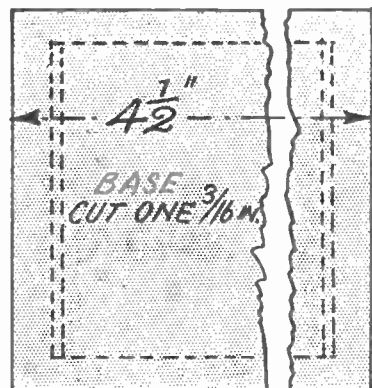
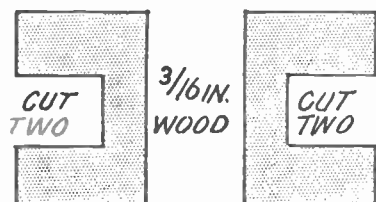
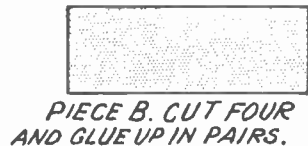
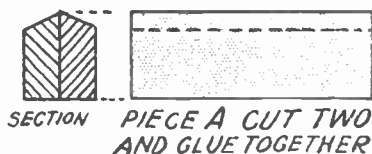
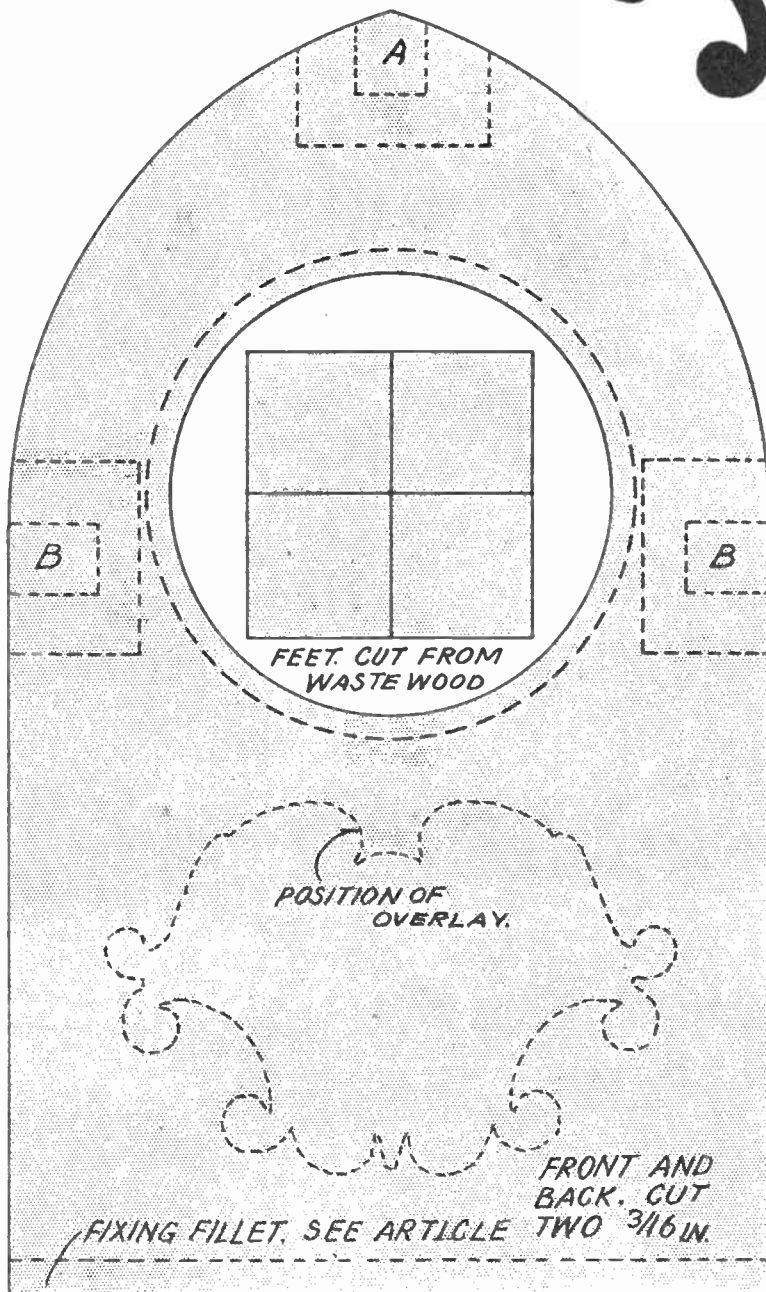



# MISCELLANEOUS ADVERTISEMENTS, etc.

The advertisements are inserted at the rate of 3d. per word or group of letters prepaid. Postal Order and Stamps must accompany the order, and the advertisements will be inserted in the earliest issue. Freework goods or those shown in Hobbies Handbook not accepted. Orders can be sent to Hobbies Weekly, Advertisement Dept., as below.

**S**ECONDHAND MOULDS for making soldiers in battledress, planes, farm animals, wild animals, racing car which runs on wheels, from 7/- each. Stamped addressed envelope for list.—15, Rosemary Gardens, Mortlake, London, S.W.14.

**10** MINT PICTORIALS, album, perforation gauge, watermark detector, 2/3.—Ahdown, 164 Woodward Road, Dagenham.

**S**TAMPS FREE! Twenty unused (2½d.).—G. H. Barnett, Limington, Somerset.

**15** FREE STAMPS, and Bargain approvals.—Brett, 16 Heathway Court, London, N.W.3.

**T**OYS—Make them yourself from oddments. Range of assorted, fascinating, popular designs with full instructions 2/6d. only post free. You will be delighted.—Harrod, 10, Beaconsfield Road, Maidstone.

**L**ONELY? Join Friendship Circle. Details 6d. Secretary, 34 Honeywell Road, London, S.W.11.

**S**ET U.S.A. DEFENCE STAMPS FREE to all sending 2½d. for Approvals.—Ramsey, 168 Legsby Av. Grimsby.

**B**E TALLER. Quickly! Safely! Privately! No Appliances—No Tablets—No Dieting. Details, 6d. stamp.—Malcolm Ross, Height Specialist, BM/HYTE, London, W.C.1

**L**ONELY? Then write Secretary U.C.C., 5B.B. Hay St., Braughing, Herts. Genuine. Est. 1905.

**M**ODELS. You can make lasting stone-hard models with Sankey's Pyruma Plastic Cement. Supplied in tins by Ironmongers, Hardwaremen and Builders' Merchants. Ask for Instruction leaflet.

**R**AILWAYS, a new "Planbook" by P. R. Wickham. "Scenic Railway Modelling" will add a new interest to constructing and operating miniature Railways. AIRCRAFT "Making Miniature Aircraft" is another new "Planbook" by R. H. Warring. It tells how to make realistic solid scale models. YACHT "Planbook" tells how to make and race Model. New simple time-saving method of construction. GAS ENGINE. "Planbook" gives instructions and drawings for working model which runs on air. Made with simple tools and materials. New technique. GALLEONS. All the secrets of making lovely models of these old-time ships are in this "Planbook" with working drawings. AIRCRAFT, SHIPS and RAILWAYS Use "Scaleline" plans. SEND 3d. and unstamped addressed envelope for list of over 100 Plans and details of above Modelcraft "Planbooks."—77(H) Grosvenor Road, London, S.W.1

## Do you take Photographs?

Your photography will become much more interesting if you do it all yourself. To help you, we will send for 3d. in stamps, these three publications. A 32-page booklet called Home-Photography which tells you how to develop your own negatives, how to make Gaslight and Bromide prints, how to do Flashlight Photography and how to make Enlargements. A folder about Azol, the concentrated one-solution developer, with full Time and Temperature tables for tank or dish development. There is also a fully illustrated list of Chemicals, useful sundries and accessories to help you in the work.

**THE THREE PUBLICATIONS WILL BE SENT TO YOU FOR 3d. IN STAMPS**

### Try this Trial Offer—

For 2/3 P.O. Johnsons will send you post free (G.B. only) a trial set of Chemicals, including 1-oz. bottle of AZOL, to develop eight spools 2½in. by 3½in., 4-oz. tin ACID-FIXING, making 30-60 ozs. solution, one packet AMIDOL DEVELOPER, enough for 2 to 3 doz. bromide or contact gaslight prints.

Be sure and address your letter to Hobbies Dept.,

**JOHNSON & SONS Manufacturing Chemists Ltd. HENDON, N.W.4**

Established 1743

Large Stocks of books on Woodwork, Metalwork, Model Aircraft, Ship and Railway Making

## FOYLES for Books

Nearly 3 million volumes in stock. New and secondhand books on every subject

BOOKS BOUGHT

119-125 CHARING CROSS ROAD, LONDON, W.C.2  
Phone: GERrard 5660 (16 lines) Open 9-6 including Sats.

## SWASTIKA STAMP PACKET FREE



We have been extremely fortunate in obtaining a supply of GERMAN stamps specially issued by the Nazi Government for use on Nazi Official correspondence only. The stamp design shows, as illustrated, the Nazi Swastika. YOU can get one of these most interesting stamps from us ABSOLUTELY FREE for your collection. In addition we will also send you some more stamps FREE including the FRANCE "Peace" stamp; HOLLAND (Queen Wilhelmina) and nice JAMAICA. All you have to do to get ALL these interesting stamps ABSOLUTELY FREE is to (1) Ask for FREE SWASTIKA PACKET; (2) Ask for an Approval Selection and Price Lists; (3) Write clearly your name and full address; (4) Place 3d. in stamps (to cover cost of Lists and postage to you of Gift and Approvals) inside your letter and post it to:—

WINDSOR STAMP CO. (Dept. 12), UCKFIELD, SUSSEX

## A Handy Glasspaper Block

A wooden block with special handle which holds glass-paper taut and always in place. In two sizes, 3in. price 11d.; 5in., price 1/9. Post extra.



HOBBIES Ltd. DEREHAM





SECTION THROUGH WING ON LINE E.E.

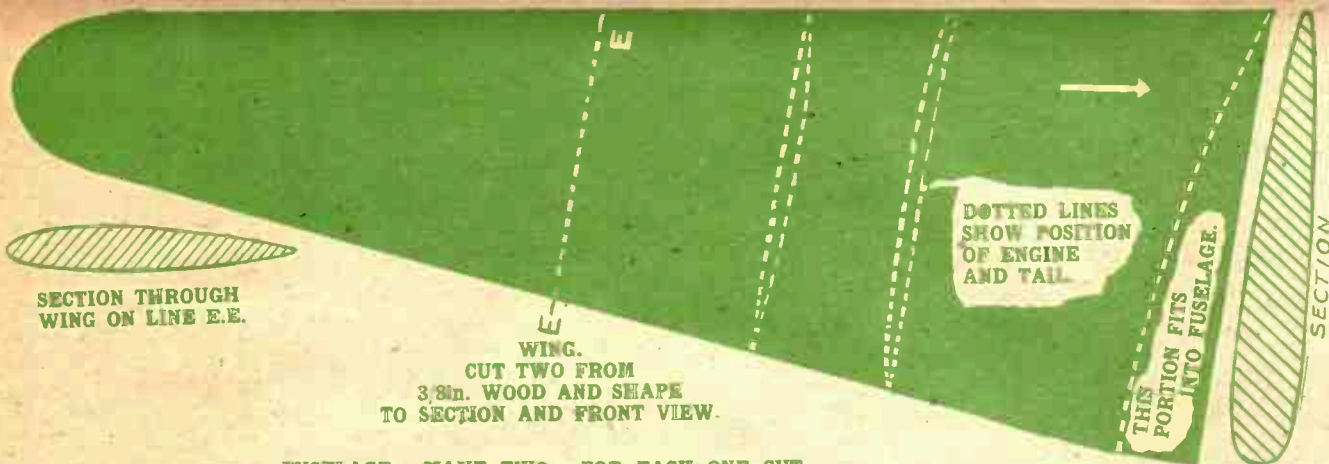

WING.  
CUT TWO FROM 3/8in. WOOD AND SHAPE TO SECTION AND FRONT VIEW.

FUSELAGE. MAKE TWO. FOR EACH ONE CUT TWO PIECES 3/8in. THICK AND GLUE TOGETHER. SHAPE UP TO THE PLAN BELOW AND THE CROSS SECTIONS.

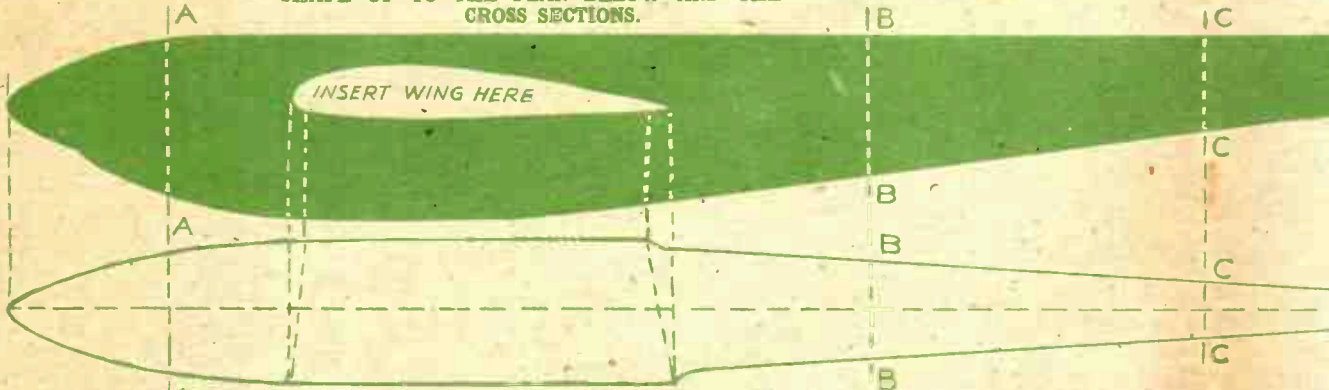

PLAN SHOWING SHAPING TO FUSELAGE AFTER PIECES HAVE BEEN GLUED TOGETHER.

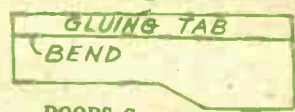
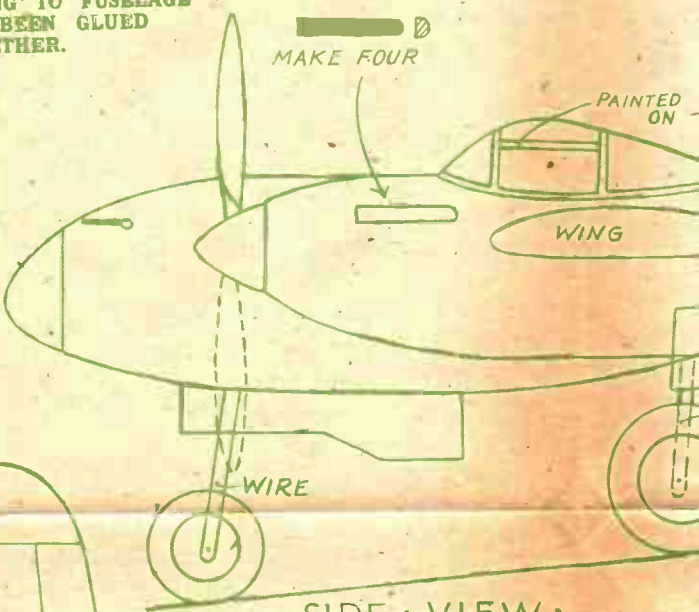
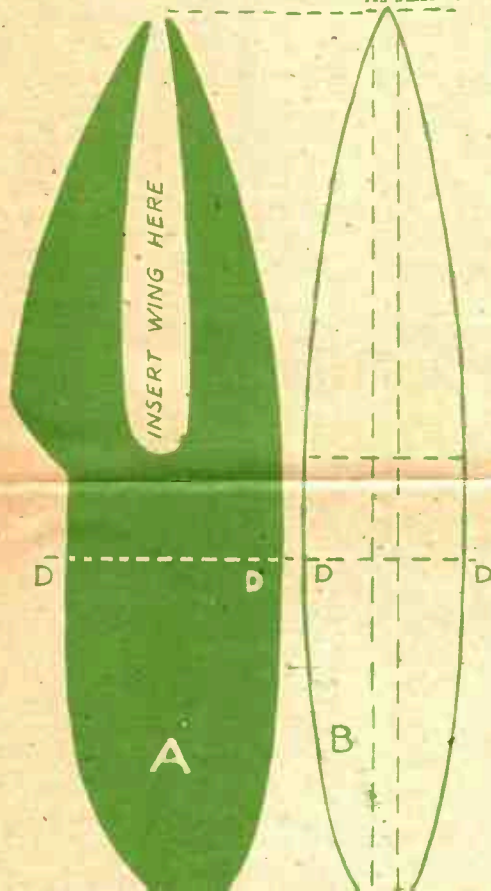

DOORS G. CUT FOUR FROM CARD.

OVERLAYS ON SIDE OF FUSELAGE CUT FOUR OF EACH FROM 1/8in. WOOD.

# MODEL AEROPLANE LOCKHEED "LIGHTNING" A FIGHTER MODEL

PANELS OF WOOD REQUIRED FOR  
THIS DESIGN

ONE G2 THREE GD6

The price is shown in Hobbies Weekly, June 21st, 1944, but is subject to revision. See the current edition of Hobbies Handbook, or write for price to Hobbies Limited, Dereham, Norfolk.

SIZE OF MODEL  
WING SPAN—13ins.  
LENGTH—9½ins.



—SCALE—  
1/4in.=1 foot.

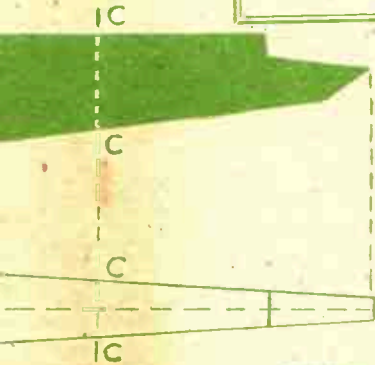
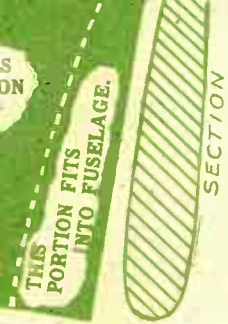

SHAPING TO  
FUSELAGE. CROSS  
SECTIONS ON THE  
LINES SHOWN ON  
PLAN, ETC.

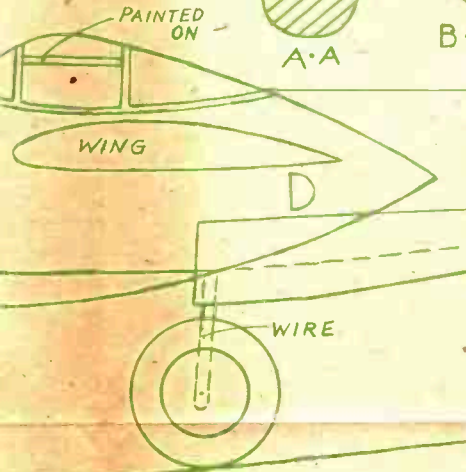

EW.

TAIL PLANE. CUT ONE 1/8in.  
AND SHAPE TO SECTION.

OVERLAYS ON  
SIDE OF FUSELAGE.  
CUT FOUR OF EACH  
FROM 1/8in. WOOD.

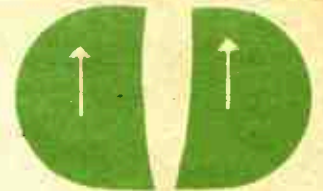
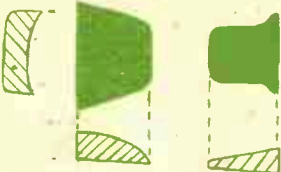

ENDS TO TAIL PLANE.  
1/8in. THICK.

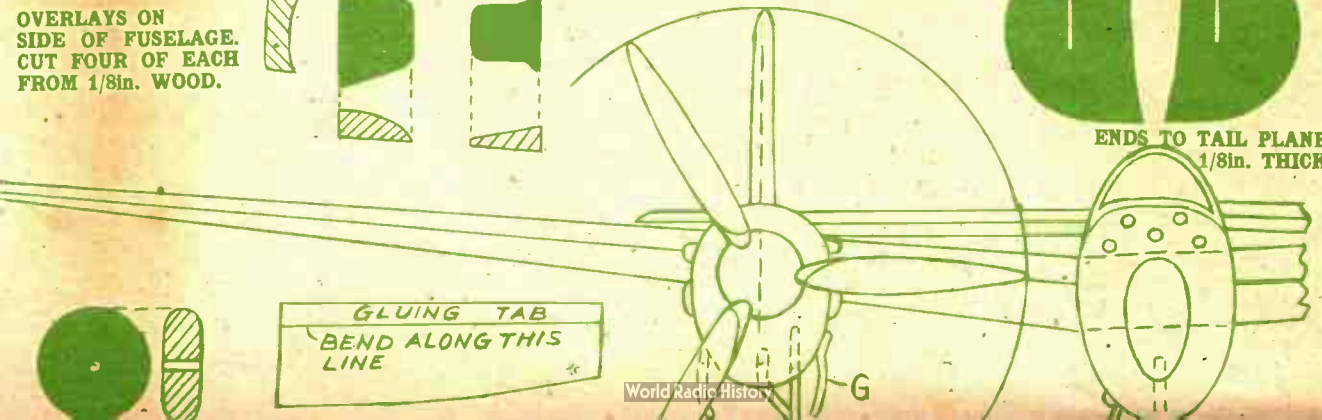

GLUING TAB  
BEND ALONG THIS  
LINE



PLAN SHOWING SHAPING TO FUSELAGE  
AFTER PIECES HAVE BEEN GLUED  
TOGETHER.

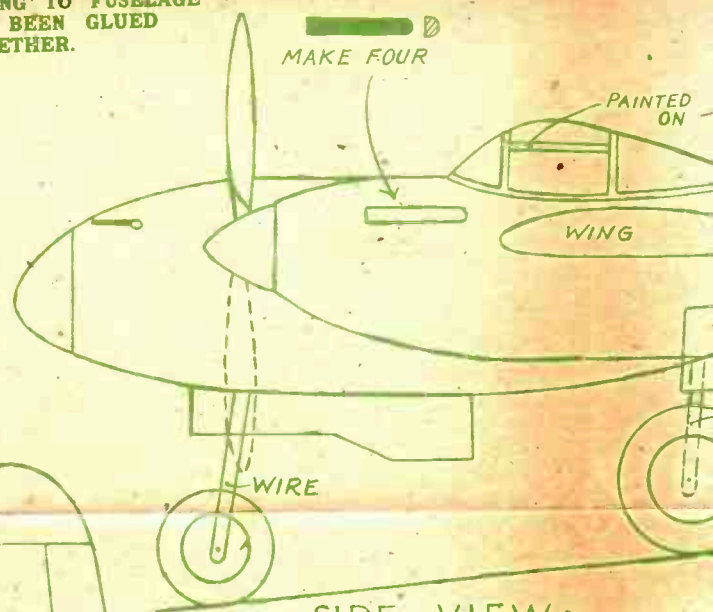
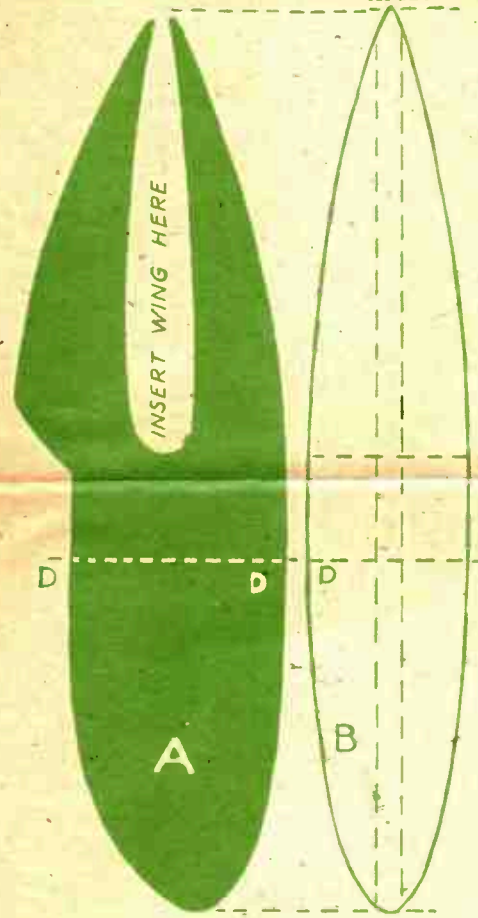

• SIDE VIEW •

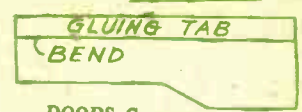

OVERLAYS ON  
SIDE OF FUSELAGE  
CUT FOUR OF EACH  
FROM 1/8in. WOOD.

DOORS G.  
CUT FOUR FROM  
CARD.

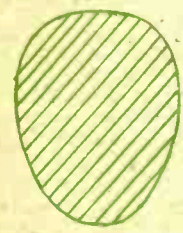

CENTRE BODY.  
CUT TWO PIECES  
3/8in. AND ONE  
PIECE 1/8in. TO  
PROFILE A, AND  
SHAPE TO PLAN B.

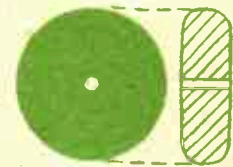
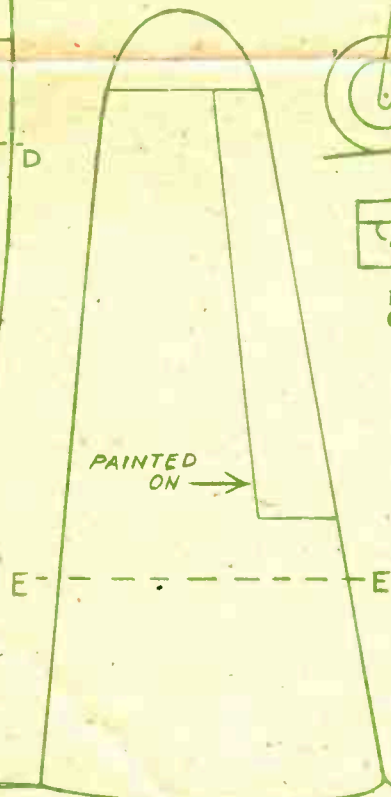

CUT TWO.



CUT ONE.

WHEELS. CUT  
FROM WOOD AND SHAPE  
AS SHOWN IN SECTION.  
FIX TO WIRE AXLES.

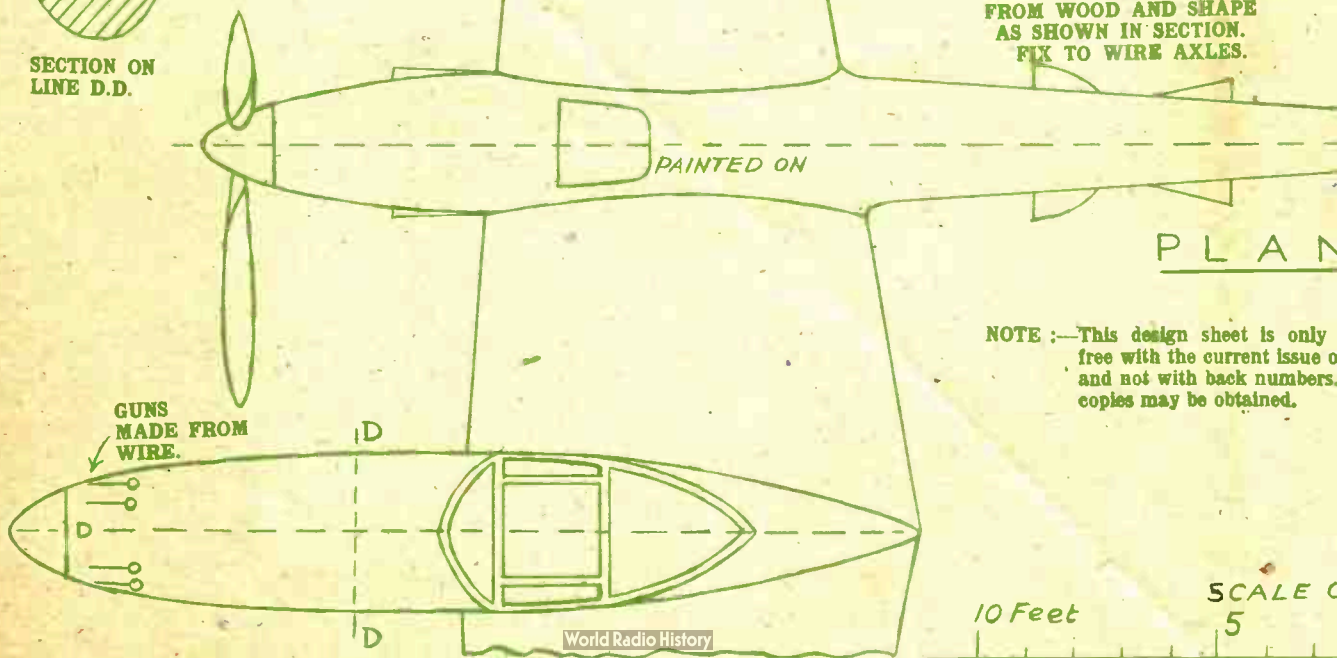

PLAN

NOTE:—This design sheet is only  
free with the current issue of  
and not with back numbers.  
copies may be obtained.

10 Feet

SCALE  
5

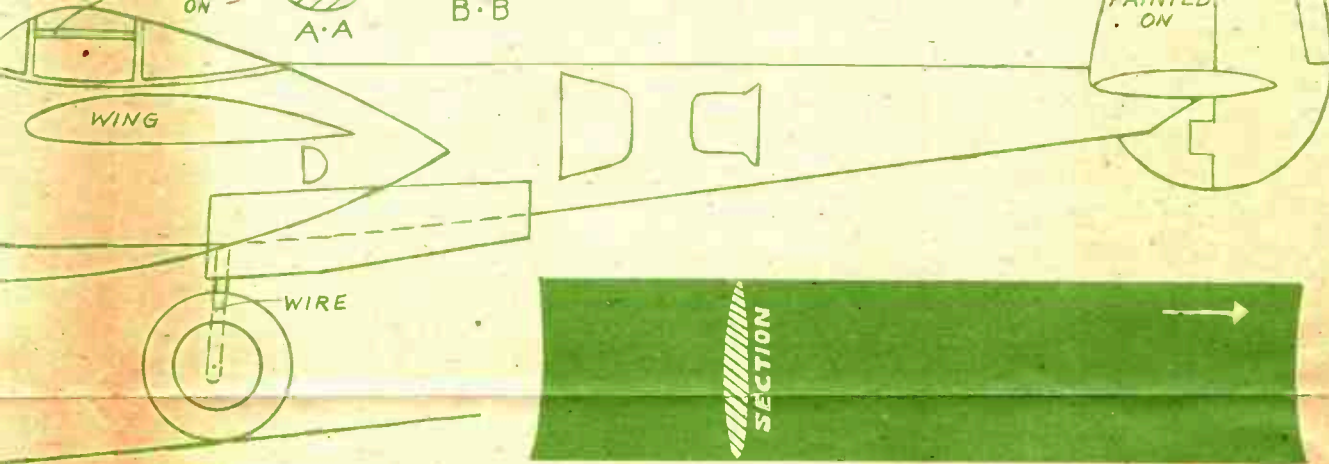

**EW**  
OVERLAYS ON  
SIDE OF FUSELAGE.  
CUT FOUR OF EACH  
FROM 1/8in. WOOD.

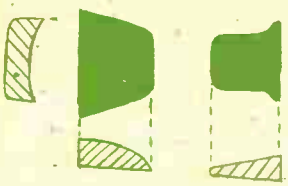

**TAIL PLANE. CUT ONE 1/8in.  
AND SHAPE TO SECTION.**

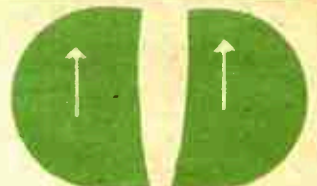

**ENDS TO TAIL PLANE.  
1/8in. THICK.**

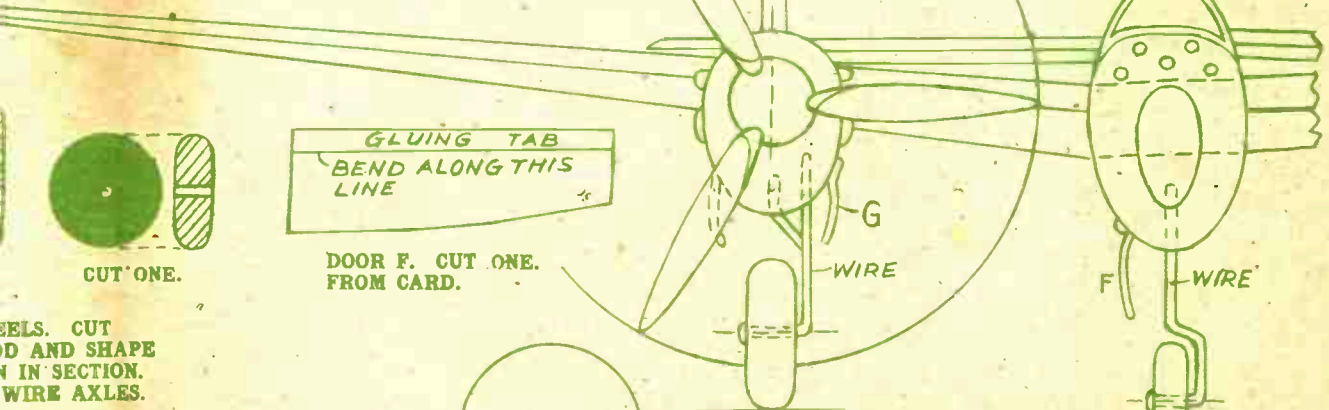

**DOOR F. CUT ONE.  
FROM CARD.**



**WHEELS. CUT  
WOOD AND SHAPE  
IN SECTION.  
WIRE AXLES.**

**FRONT  
VIEW**

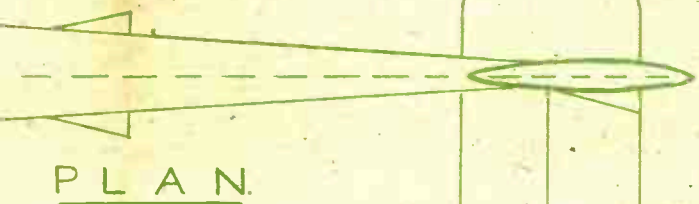

**PLAN**

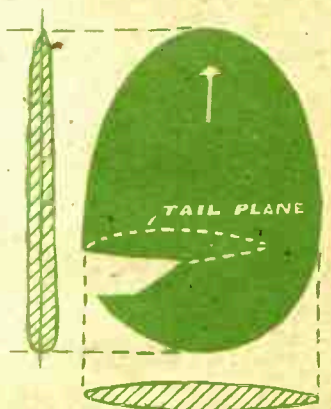

This design sheet is only presented  
with the current issue of Hobbies  
and not with back numbers. Further  
copies may be obtained.

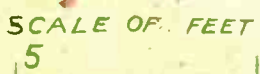

**PRINTED IN ENGLAND.**

**10 Feet**



# MODEL LOCKHEED LIGHTNING

**T**HIS model of the famous Lockheed Lightning fighter follows the same lines for construction as the other Hobbies planes, apart from the fact, of course, that it has a short fuselage in the centre, and long twin booms leading to the tail. All parts are cut in wood, for which a parcel is supplied as shown, and the patterns on the other side give all the necessary details of sizes, shapes, etc.

The best plan is to mark these shapes on to the wood direct by means of carbon or tracing paper, and then to cut them out with the fretsaw to their first outlines. Afterwards they will have to be shaped up according to the correct curves by means of a rasp, file, and finally glasspaper.

This shaping must be done carefully, with reference to any pictures you may be able to obtain, the correct balance of the wings must be maintained, the two booms must be identical, and the carefully rounded fuselage must be nicely shaped to the torpedo body shown.

Before commencing, study the sheet to ensure that you know the details of the parts, and where they fit. Various side and front views as well as plans are given, and these provide all the details necessary.

In the case of the twin booms and the centre body, the pattern shows a side view and a plan looking at it from above. Pieces have to be cut out to the shape of the side view, and then curved off according to the plan. Each piece of the boom is made of two boards of  $\frac{3}{16}$  in. glued together. The centre body portion is  $\frac{1}{2}$  in. board glued between two  $\frac{3}{16}$  in.

The outline of each can be cut separately, the parts glued together, and then the shaping commenced. Notice in the fuselage pieces there is an opening for the insertion of the wing. The aperture indicated is for the widest part, but as it tapers, so the opening in the fuselage must taper.

The length of the smaller shape is indicated by the inner dotted lines,

and it is perhaps advisable to cut the opening to this for the wing and then taper outwards to accommodate that part when it is fitted in.

Otherwise, when the wing is put through, you will have a gap where it has tapered off, and this will have to be filled with plastic wood or putty.

The wings themselves, of course, taper on both leading and trailing edge, and are shaped as shown by the sections. Fit them into the centre, body piece to be in line with the plan view at the bottom of the sheet. The wing passes through the boom portion which in turn has been rounded off before fitting on.

Remember that the pilot's cockpit is cut with the main portion of the centre body, and the actual perspex hood and framework must be painted later.

There are slight bulges on each fuselage piece, and these are cut according to the pattern shown and glued on at the line BB according to the section.

The tail is a complete plane running to the two booms. The first piece to be glued on is the upright fin and rudder, for which an accommodating slot is made to slide over. The piece rests on the shoulder cut in the boom itself, and is there glued upright.

Between these two is fixed the tailplane, the ends of which are slightly curved concave to the same shape as the fuselage itself. Their position is shown in the side view, and a nail can be driven through the fin portion to help to steady the whole thing.

These little headless nails are afterwards covered by the ends of the tailplane, which are then glued on the outer side in line with the main portion. You can see them in the plan at the bottom of the sheet.

The tricycle wheels are also cut from wood, the two larger ones being required for fixing under the engine nacelles, and the third smaller one forward under the centre body. A

piece of wire is shaped as shown in the front view.

One end passes through the wheels which have been shaped up, then the end flattened out to form a head holding it in position. The other end is filed to a point, and the whole thing driven into the body of the plane in the positions shown in the front and side views. A little support strut of wire is also driven in and soldered to the larger wheels under the engine booms.

The wheel aperture cover is cut from card with a portion of it allowed for a gluing tab. Notice that these door pieces differ, F being glued to the centre portion, the two pieces G to the rear wheels. Bend a portion of the tab as shown, glue this piece on and let the remainder of the card hang downwards as though the door of the wheel aperture were open.

Three propellers are required for each engine, and when these have been shaped as shown by the detail, they are glued in the small holes bored around the spinner. Glue them firmly in place and cut in a slight line behind them to form the joint of the spinner and the engine fairing.

It is probably best to paint the model before the minor additions are added. That is, before you have fixed on the wheels, props, guns, etc. Get a flat coat on first, and then paint the model in its appropriate colours as a fighter.

The perspex of the pilot's cockpit can be painted on light blue, with the framework dark brown. Roundels and targets can be added to the wings and the fuselage, whilst the opening of the doors can be painted on underneath. Flaps, rudder, etc. are also indicated in line on the various patterns, and these, too, can be carefully drawn on as a thin line in black.

If you are proposing to have the model hung as in a flying position, then the whole of the undercarriage wheels and the doors can be omitted.