



Radio Constructor

Vol 1 No. 3

Annual Subscription 16/-

October 1947

Editors :

ARTHUR C. GEE, G2UK

W. NORMAN STEVENS, G3AKA

Advertisement & Business Manager :

C. W. C. OVERLAND, G2ATV

Editorial

WITH the drawing in of winter evenings, our thoughts turn from outdoor activities to indoor hobbies and those of us who are radio constructors will be looking forward to bringing into reality some of the castles in the air we have built under the hot cloudless skies of this past summer. Just as in spring we get the urge to get out of the shack and "go portable" or abandon radio altogether for some more outdoor activity, so at this time of the year, we feel a desire for the cosy fug of the shack, the smell of hot solder flux, the pleasant hum of power packs. Where is our constructional programme taking us this winter? What should one's aims be?

Our hobby is a progressive one. Like the amateur photographer, the amateur artist, the amateur carpenter or model engineer, there is no finality to our craftsmanship. Every receiver we build falls short in some respect from our ideal—from what we imagined it might have been. Our new transmitter is not quite so convenient to band-change as we had hoped. The quality of our latest gramophone amplifier could still be better. And so most of us plan a rebuild of some sort this winter.

We are often laughed at by our friends and relations for these frequent rebuilds and there are times when some of us wonder ourselves whether we weren't crazy to have pulled last winter's gear to pieces and replaced it with the present unstable, gremlin-sodden, parasite-infested bit of gear our latest creation appears to be! But the fun of the game is in sorting out the difficulties

and next year we'll be doing the same again and liking it! It's all part of the craftsman's art—the search after something still better.

Having excused ourselves this inevitable rebuild, in what directions should our energies be directed to ensure improvement? Two suggestions have been made to us recently and we feel they are worth passing on.

The first is that we should aim at a better "finish" to our gear. We are very inclined to patronise the saying that, "it doesn't matter what the gear looks like as long as it works." There was a time when that was true. Enough satisfaction could be had by managing to get radio gear working. But those days have gone. All but the most complicated gear works pretty well "first time off" nowadays and we should therefore be able to give more time to making it "look good" as well as work properly.

The second suggestion is that we should forsake the "all on the level" style of construction and try something rather more ambitious. The neat, compact little transmitters supplied to the services toward the later part of hostilities are an example of what we should attempt to copy. A basic framework, with individual chassis for each unit of the gear, compact construction and built-in power packs would produce gear showing a marked advance over that at present in vogue in amateur practice. The argument will be put forward that the metal work involved is too difficult for the facilities possessed by the average constructor. Our answer to this is that we are
(Cont. on p.76)

NOTICES

THE EDITORS invite original contributions on construction of radio subjects. All material used will be paid for. Articles should be clearly written, preferably typewritten, and photographs should be clear and sharp. Diagrams need not be large or perfectly drawn, as our draughtsmen will redraw in most cases, but relevant information should be included. All MSS must be accompanied by a stamped addressed envelope for reply or return.

Each item must bear the sender's name and address.

COMPONENT REVIEW. Manufacturers, publishers, etc., are invited to submit samples or information of new products for review in this section.

ALL CORRESPONDENCE should be addressed to "Radio Constructor," 57 Maida Vale, Paddington, London, W.9. Telephone CUN 6579.

AUTHENTIC AND UP-TO-THE MINUTE INFORMATION ON V.H.F., BROADCAST BAND AND AMATEUR ACTIVITIES IS GIVEN IN OUR MONTHLY PUBLICATION "SHORT WAVE NEWS."

What Value ?

By Centre Tap

SINCE the "preferred" range of values for resistors was introduced, I have normally specified those values in circuits described for home construction. One of the ideas of the manufacturers in deciding on this range was, I believe, the eventual reduction in the number of sizes needed to be carried both from the set Manufacturers' and the Servicemans' point of view. Recently, with other designers of gear for amateur construction, I have been taken to task for not clarifying the "tolerance" (in other words the tolerable variation with any given resistor in its particular circuit) permissible in the designs described. Radio dealers, in these days of difficulty of maintaining normal stocks, have already enough of their share of worries without this further complication which might be eased by simple explanation.

Following the appearance of the "Basic Superhet" two dealers who handle much mail order business, told me in no uncertain terms that profits of subsequent sales were greatly reduced in chasing round obtaining certain parts (often at retail rates) merely to enable them to complete orders. It is pleasing to know that they have been to such trouble rather than endanger their reputations by long delays in supplying. Even the "S.W.N." Staff have their grumble in this respect, having to answer hundreds of enquiries and return numerous remittances with apologies for being unable to supply back numbers.*

However, difficulties of that nature cannot be avoided but it is difficulties which can well be avoided with which we are immediately concerned.

"Sales Resistance"

Chief among these is the actual value of the resistor and here we run up against the problem of the two ranges, the normal values (50, 100, 25,000, 50,000 and 100,000, being typical examples) and the preferred (of which 47,000, 22,000, 27,000, etc., are examples).

In normal times a dealer can easily carry a range of both types and everyone is happy, particularly if a 47,000 ohms resistor is sold to a customer who already has a couple of 50,000 ohms resistors lying idle at home!

* (Very occasionally odd copies of earlier issues which have been reserved for special purposes are available and whenever possible these are supplied to the readers who have enquired for them.—E.D.)

Let us try to get down to the real situation. As the original design used a 47,000 ohm resistor, for example, the beginner tries to buy one of that value but his dealer says "Sorry, O.M. the nearest in stock is 50,000 which will do equally as well." The customer may be of the suspicious type who feels the dealer is unscrupulously attempting to force a sale, or he may be of the nervous type who has set much hope on his model having as good a performance as the original. In either case he mumbles his apologies and tries elsewhere, feeling that if the 50,000 would really have served as well surely the designer would have said so.

If the dealers' assurance does not convince him by verbal explanation, you can well imagine the exasperating complications when handling mail orders. As to the real position—designers invariably specify, particularly if the value of a resistor should be accurate within plus or minus 20 per cent. as most ordinary resistors are only guaranteed by the manufacturers to be within a "tolerance" of that figure. In other words, a resistor supplied as being of 100,000 ohms may have an actual resistance of any figure between 80,000 and 120,000 ohms. In point of fact most resistors I have measured have been found to be much nearer to the marked values than they are to the limits of their tolerance, but most certainly the substitute offered by the dealer is perfectly satisfactory. In most cases too, it is normally simply a matter of the range in which a designer normally works whether he chooses 47,000 or 50,000.

Narrower Tolerances

If it is necessary to use a resistor having an accuracy of plus or minus 1 per cent. or less (as is the case when required for meter shunts, etc.), you will find that you have to pay considerably more for it, and the closer the tolerance the more sharply the price rises. Apart from special markings on these close limit resistors, it will often be found that when of the carbon type they are flattened on one side. These were originally of lesser resistance than the final figure, and then ground until they came within the quoted percentage of the specified figure. Naturally one would expect to have to pay extra for this individual tailoring.

In recent years it has become the practice for manufacturers to mark the tolerance percentage, those within 5 per cent. being marked with a gold spot or band, and

those within 10 per cent. marked with silver. Where there is no marking it is assumed that the accuracy is within 20 per cent.

Wattage Rating

It also often happens that a constructor has resistors of a specified value but of only $\frac{1}{2}$ or $\frac{1}{4}$ watt rating, and he wonders if it is possible to use it in the circuit. This can quite easily be determined by applying the following formula

$$\frac{\text{Watts (Rating)} = (\text{current in mA.})^2 \times \text{Resistance}}{1,000,000}$$

Thus to find a suitable resistor of 10,000 ohms required to carry 7 mA. we calculate

$$\frac{49 \times 10,000}{1,000,000} = .49 \text{ watts}$$

In this actual instance we find that a $\frac{1}{2}$ watt type could be made to serve, but the safety margin would be so narrow that at least a 1 watt type should most certainly be used.

Making Up Values

It must be remembered that resistors wired in series have their values added and two 50,000 ohm resistors so joined would have a total resistance of 100,000 ohms. If connected in parallel their resistance is halved, becoming 25,000 ohms while the wattage rating is doubled. Thus if both of the 1 watt type, they virtually become as a single resistor capable of dissipating 2 watts.

By making up combinations in this manner, considerable expense and trouble can be saved particularly when odd values are required. To take a simple example—a 12,500 ohm (1 watt) resistor is required but unobtainable. Two $\frac{1}{2}$ watt 25,000 ohm resistors connected in parallel become exactly the same thing. It does not matter, of course, if they happen to be one watters. Indeed it is all to the good, the more generous the wattage rating margin, the better, and it is a safe rule to allow 100 per cent. over the calculated value.

Resistors must never run hot. That their resistance changes with temperature variation is but one reason. The heat will introduce drift in tuned circuits and high working temperatures will frequently shorten the useful life of other components quite apart from a certain breakdown in the resistor itself.

FROM THE MAILBAG

Dear Sirs,

I would like to see a seven-valve SW Superhet described covering, say 10-180 metres and then a converter for 5 and 10 metres, I suggest the following points:—

- (1) Complete list of specific parts (makers names given).
- (2) Diagram showing position of all main components, above and underneath the chassis. Also positioning of valve holders and coils in order to give shortest possible wiring.
- (3) Good circuit diagram of receiver.
- (4) Valve complement:—R.F. stage, Triode-Hexode Frequency Changer, two I.F. Stages (with iron-cored coils), Double-diode-triode as 1st audio amplifier and A.V.C., Pentode output to give around 3 watts audio output, Rectifier* (with very good smoothing circuit).
- (5) Chassis to be large enough to allow the later inclusion of BFO, noise limiter and crystal filter circuits.
- (6) Tuning to be effected by 3-gang capacitor, 100 μ F.
- (7) Power pack to be situated well away from main part of receiver. Electrolytics to be the plug-in type.
- (8) Only the very best of components to be used.
- (9) A nice clean and neat layout. Robust job to last years (i.e. tropicalised components, metal cased mains transformer, etc.)
- (10) Systematic panel controls and good slow motion drives. No haphazard controls at any convenient point.
- (11) Good plug in coils to be employed.
- (12) If possible fit electrical band-spread tuning as well as the main band-spread (mechanical).

From the above you can see easily what I would like to be described. I cannot overemphasize the need for a clean and neat layout, not cramped, and de-luxe components used throughout.

Yours faithfully,
G. L. Macpherson (Dundee, Angus)

(We would like to hear what other readers have to say regarding the above suggestions. Let us hear what you have to say on the subject.—Ed.)

The Straight Receiver

Part 3.

By H. A. Emm

Audio Amplification

BEFORE going on to the various methods in use, it is opportune here to study briefly the action of a valve, taking a triode as an example. The triode has three electrodes, the cathode, anode and control grid.

The cathode is formed of certain metals, such as tungsten, or oxides, such as barium and strontium, which possess the property of giving off, or emitting, electrons when heated to a suitable temperature. This latter is obtained by passing current through a filament or "heater," adjacent to the cathode in the case of an indirectly heated valve, and either of the same material as the cathode, or having this material deposited on it, in a directly heated valve.

The anode and the control grid are made from a variety of metals, most often nickel or molybdenum. The anode is generally made from sheet metal, enclosing the remainder of the valve assembly, while the control grid is usually made from wire in the form of a spiral, and is situated between the anode and the cathode.

When the filament voltage is applied, electrons are emitted from the cathode and remain nearby. If now a positive potential is given to the anode, electrons will be attracted to it, as they are negative, and current will flow. The higher the anode potential, the greater will be the current, until a point is reached where all the electrons emitted from the cathode are

attracted to the anode. This is known as "saturation point," but it does not occur in practice as the cathode is so made that it will emit a surplus of electrons when the anode is operating at the rated potential. The excess of electrons remains near the cathode, and is called the "space charge." Should the anode potential be made negative in respect to the cathode, then it will tend only to repel the electrons, and no current will be passed. This effect is made use of, as we have seen, in the application of a diode valve as a detector or rectifier.

The potential of the control grid will have an effect similar to that of the anode, in the sense that it will tend to attract or repel the electrons, according to its potential being positive or negative. Due to the construction of the grid, the majority of the electrons will pass through the interstices and go on to reach the anode, only those which actually impact on the grid causing grid current to flow.

If the control grid is made sufficiently negative, it will cancel out the attractive effect of the anode, and no current will flow. As the grid potential becomes less negative, the anode will start to have an effect, and current flow will commence, increasing as the grid becomes more positive. Grid current, of course, will not begin until the grid is at a potential above that of the cathode.

So far, we have seen that with a given anode potential, the anode current will depend on the potential applied to the control grid, and that changes in the latter will be reflected in corresponding changes in the anode current. Without delving too deeply into theory, it will be found that a small change in grid potential produces a larger change in the potential developed across the anode load impedance, through which the anode current flows.

Now let us consider Fig. 5, which shows two methods of obtaining amplification at

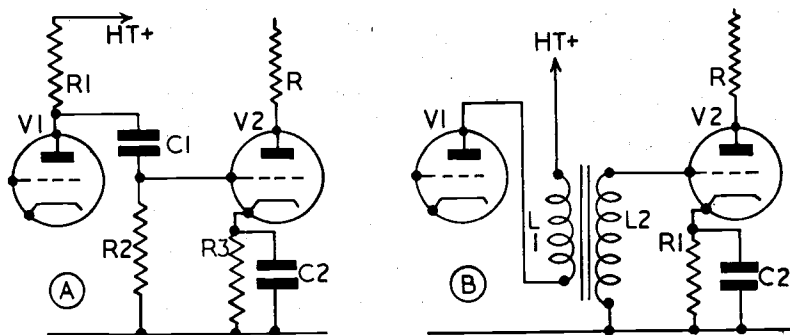

Fig. 5

audio frequencies. Fig. 5a, illustrates the method known as "resistance-capacitance" coupling, usually abbreviated to "RCC." V1 represents a detector stage, and R1 is the anode impedance of the detector, across which is developed a potential at audio frequencies of varying amplitude. There is also a steady DC potential, and if this were applied to the control grid of V2, the amplifying valve, grid current would flow and distortion be introduced. To prevent this, a coupling capacitance C1 is used, which has an extremely high resistance (infinite in theory) to the passage of DC, while presenting a low impedance to the AF voltage. R2 is a grid leak, so called because it allows to leak away the small quantity of electrons which collects on the control grid, as we have seen. If there were no conducting path to the cathode, this negative charge would build up to such a value that "cut-off" point would be reached, and the valve would cease to pass anode current.

R2, in parallel with which is the effective grid/cathode resistance and grid/cathode capacitance of the valve V2, in combination with the capacitance C1 forms a potentiometer, and only the voltage developed across R2 is applied between the grid and cathode of V2. This voltage is required to be as large as possible, in order to obtain the maximum amplification, and therefore the leak R2 should be as large as is possible, but not so large that the electrons on the control grid are prevented from leaking away. Similarly, the reactance of C1 should be as low as possible. Typical of the values used in practice are .005 to .1 μ F for C1, and .25 to 1 megohms for R2.

The necessity for biasing the control grid has not, so far, been considered. One reason is that, during positive half-cycles of the AF input, the grid might be at a higher potential than the cathode, in which case grid current would flow and distortion be caused. This can be prevented by applying a negative potential to the grid, of such a value that it exceeds the peak positive potential of the AF input. Another reason is that distortion will also occur if the potential on the control grid becomes too negative, due to the fact that the ratio of change of grid voltage to change of anode current then varies, and linear amplification is no longer obtained. This can be more readily seen if a graph is plotted of the anode current of a valve, at a given potential, against various potentials on the control grid. An example of the resultant curve is given at Fig. 6, where it will be seen that the change in anode current is linear between two certain points, one when the grid potential is -3 volts, and

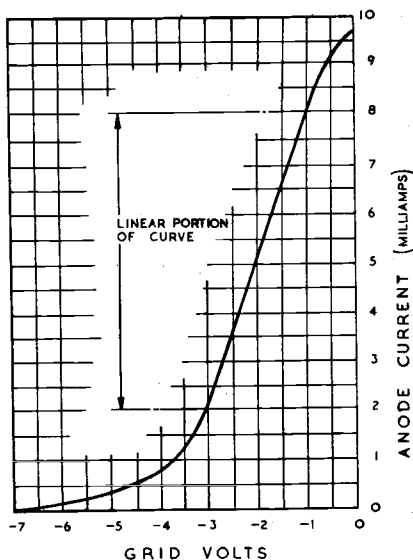

Fig. 6

one when it is -1 volt. It will also be seen that the potential to be applied to the grid so that the maximum signal can be handled without distortion is the potential midway between these two points. In this case the negative bias is 2 volts; in practice, the correct voltage is given by the valve manufacturer, either with the valve concerned or in his valve literature.

In Fig. 5a, the necessary potential is obtained by virtue of the voltage drop across R3 due to the passage through it of the anode current of V2. Both the grid and the cathode are connected finally to HT—, and as the cathode becomes positive with respect to HT—, it follows that it also becomes positive in regard to the grid, or, in other words, the grid is then negative compared to the cathode.

The cathode is also part of the output circuit of the valve, i.e. the current passing through R3 will vary at AF in exactly the same manner as the anode current, and the bias voltage will vary accordingly. To prevent this happening, the AF variations are bypassed by shunting R3 with a large capacitance, which is usually made of the order of 25 to 50 μ F.

With directly heated valves of the mains type, the same system can be used, though here we have the cathode (filament) at differing potentials along its length. This is overcome by connecting R3 to the zero point, which is conveniently provided by the centre-tap of the heater winding, or the centre point of a potentiometer connected across the winding. With battery

valves the usual method is to obtain the necessary bias voltage from a small battery, the positive socket being taken to HT— and the various grids returned to the appropriate sockets.

Yet another system is sometimes employed. In this, HT— is connected to the valve cathodes (filaments) via a resistance, across which is developed a voltage drop by the total current of the set passing through it. HT— itself is therefore negative with respect to the cathodes, and by tapping the resistance at various points, negative potentials can be obtained to which the control grids can be returned. In mains receivers, the resistance generally takes the form of the speaker field winding, and this also serves the purpose of a smoothing choke. The various potentials are then taken from a voltage divider, consisting of high value—low wattage resistors in series, connected in parallel with the field winding.

Where battery receivers are concerned, the number of battery leads needed is reduced, but the system has a disadvantage in that the total HT voltage obtainable is the nominal value reduced by an amount equal to the highest grid potential required.

Again the resistance is shunted by a large capacitance, and this is usually of the electrolytic type, so that the correct polarity must be observed. The easiest way to ensure this is to remember that the negative end of the capacitor must be connected to HT—.

To sum up, a varying AF potential applied to the control grid results in corresponding variations of the anode current, which in turn causes a varying AF potential to be developed across the anode impedance. If the operating conditions are correct, this output potential will be an amplified version of the input.

(To be continued)

CAPACITANCE

By W. JORDI

WHAT is capacitance? For an explanation we must first study static electricity, or, in other words, stationary electric charges. When such charges are set in motion, the movement becomes an electric current, formed by electrons (negative charges) leaving the atoms to which they are normally attached, and travelling until they reach other atoms which are deficient in electrons. Materials whose atoms easily give up electrons are known as **Conductors**, and materials that resist this procedure to a very high degree are known as **Insulators** or **Dielectrics**. To get back to electrostatics, when an object is charged, then it has either a surplus of electrons, or negative charge, or else a deficiency or positive charge. Around this charge is created an electrostatic field, the potential of the field being directly proportional to the charge, i.e. Q (charge) V (potential), or $Q = CV$, where C is constant of proportion, otherwise known as

the **Capacitance** of the charged body or object. The unit of capacity is the **FARAD**, a conductor having a capacity of one farad when the potential is raised one volt by the addition of one coulomb to its charge.

From the above, it will be seen that every body has a certain capacity, but normally it will be very small. By confining the field and so increasing the charge for a given potential, we can increase the capacitance. Devices which accomplish this are known as **CAPACITORS**, often called **CONDENSERS**. Let us consider the simple form shown in the diagram. The capacitor consists of two metal plates separated by a dielectric, and charged by means of a battery controlled by a switch. When this switch is closed, there will be a movement of electrons through the circuit until the potential difference between the plates becomes equal to the potential difference of the battery. Plate 2 has gained electrons, and is therefore negatively charged, while Plate 1 has lost electrons and has a positive charge. An electric field will be created by the charged plates, and will be concentrated in the dielectric separating them. The closer together the two plates, the greater the charge for a given potential, and hence the greater the capacitance. When the switch is opened, the plates will retain their charges indefinitely, given no leakage in the dielectric, which of course does not obtain in practice. If the capacitor is now placed in a closed circuit, there will be a movement of electrons, from the negative to the positive plate, until they are distributed equally around the circuit.

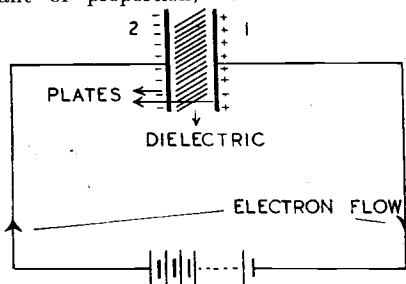



A Four-watt Quality Amplifier

By G. W. Bolton

Describing an easily built high fidelity unit

HUNDREDS, possibly thousands, of enthusiasts have during the past few months acquired some Government surplus radio gear.

Much of this cannot be used in its present state, and most of it has to be stripped down for component parts. Here is an article describing the construction of a versatile and compact amplifier, built almost entirely of surplus materials. Its uses are many and varied, being equally suitable for all types of pick-ups and radio inputs.

Arrangements are made to supply voltages from a socket in the amplifier to enable experimenters to try out various ideas, such as Pre-amplifier unit for Sound-on Film, microphone, Broadcast or short-wave tuner units.

All valves are ex-Government surplus, the line-up being as follows, input VR55 (EBC33) Schmitt phase inverter using 2 VR56 (EF36) driving 2 VT52 (EL32) in push-pull triode connected; rectifier is a 6X5G or OZ4, being interchangeable without alteration.

The circuit is simple, easy to construct, and is capable of really excellent reproduction, using moving iron, E.M.1 Lightweight, and Moving Coil units.

Maximum output approx. 4 watts undistorted for about .3 volt input. A close speech microphone, using suitable transformer gives good results, but an extra stage must be used for the Concert Type microphone. By substituting larger valves in the Output Stage, and using suitable modulation transformer (Plus higher D.C. volts as required) this circuit would be ideal for 25 to 30 w. modulator unit.

Now let us dissect the circuit:—

Input is via co-axial plug and socket, the screening being very effective—an essential owing to the high gain of the amplifier. There is an equaliser circuit R1, R2 and C1 (between input plug and volume control) to compensate for bass attenuation in recordings.

The one megohm potentiometer volume control (R3) has been placed well up in the front as it is not possible to tell what inputs you will use, and as excessive inputs

will overload the first valve, the distortion caused will be amplified considerably, maybe leading one on a false trail.

The input valve is used as a high gain triode, the diodes (Pins 4 and 5) being connected to cathode. The anode circuit is decoupled with 50 K $\frac{1}{2}$ w. resistor (R6) and 8 μ F electrolytic capacitor (C5) the case of which must be isolated from earth.

Use has been made of this as a feed-back device involving no extra components. The principal is that the voltage appearing across the secondary of the output transformer is fed back as a degenerative voltage into the anode circuit of the input valve. Something cannot be got for nothing, and this voltage feed-back decreases sensitivity but it has the advantage of flattening the response curve of the amplifier, increasing the power output rating with minimum distortion, and cancelling hum and valve noises to a marked degree.

If you should experience any instability, reversing either the primary or secondary connections to the output transformer will effect a cure.

A .1 μ F capacitor is used for coupling to the grid of Schmitt phase inverter. The input voltage appearing across R10 being 90 degrees out of phase with the input and is fed into the bottom half of the phase

inverter stage, this giving equal volts 180 degrees out of phase to both valves, and self-balancing push-pull action.

The Schmitt is a well tried circuit, and considerable tolerance can be allowed in resistor values, R7 and R8 should be within 10 per cent. of each other, as also R11 and R12.

As these valves are used as pentodes (R5 acting as degenerative feed-back) the voltage gain is about 90, this being ample to drive PX25's or KT66's if required. Both anodes are capacitance coupled to the grids of the output valves. A common bias resistor of 1 watt rating 500 ohms (R16) should be used.

The output valves are capable of 8 watts output as pentodes, but in this particular case they are used as triodes (screen connected to anode through 100 ohms) as this improves results tremendously, and at the same time, gets rid of that excessive top response allied to pentodes. No tone control has been found necessary under these conditions. The output transformer of 5 watt rating, should be 10,000 ohms anode to anode matched to speaker impedance.

Formula for this $\sqrt{\frac{\text{anode load impedance}}{\text{speech coil impedance}}}$

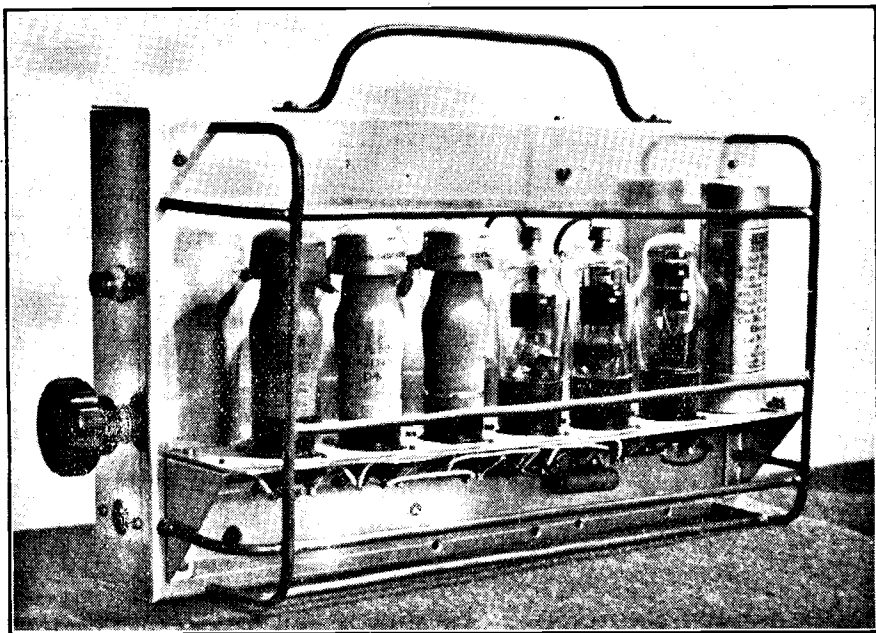

Front view of the amplifier. Note the construction of the tubular protective grill

Parts List

- | | | |
|---------------|-----------|-------|
| R1 | 100K~ | 1/2 W |
| R2 | 100K~ | 1/2 W |
| R3 | 1 Megohm | 1/2 W |
| Potentiometer | | |
| R4 | 2.2K~ | 1/2 W |
| R5 | 220K~ | 1/2 W |
| R6 | 50K~ | 1/2 W |
| R7 | 2 Megohms | 1/2 W |
| R8 | 2 Megohms | 1/2 W |
| R9 | 220 ohms | 1/2 W |
| R10 | 10K~ | 1/2 W |
| R11 | 100K~ | 1/2 W |
| R12 | 100K~ | 1/2 W |
| R13 | 220K~ | 1/2 W |
| R14 | 220K~ | 1/2 W |
| R15 | 220K~ | 1/2 W |
| R16 | 500 ohms | 1/2 W |
| R17 | 100 ohms | 1/2 W |
| R18 | 100 ohms | 1/2 W |

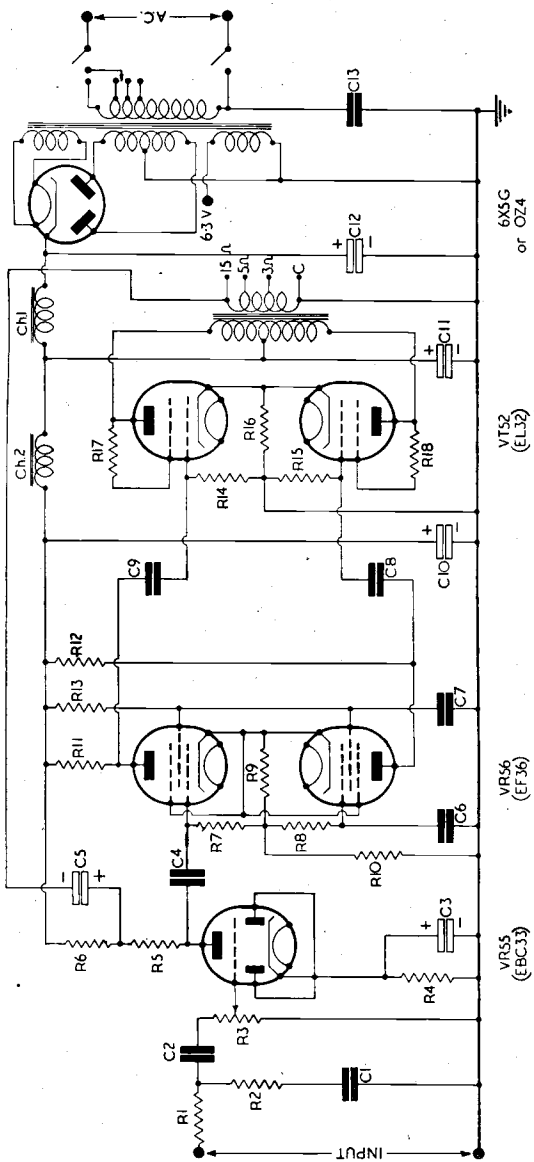

Brackets 3 1/2 in. x 3 1/2 in. cut diagonally
3/16 in. Copper Tube approx. 6 feet.

Specification for Mains Transformer

- 0-210-230-250 v. input 50cps.
- 250-0-250 v. 60 mA. Secondary
- 6.3 v. 1 Amp. for Rectifier
- 6.3 v. 2 Amp. for Valves

Output Transformer (5 W)

- 10,000 ohms Anode to Anode
- 0-3, 5, 15 ohms Secondary

Input Plug and Socket Co-Axial

Output Plug and Socket

Mains Plug and Socket. 2 pin Flex Connector

Mains On/Off Switch. DP/ST Toggle

17 pair Tag Board

Screened Top Caps

Screened Lead

Octal V/holders

Plastic covered .028 in. tinned copper wire

Brackets for fixing back cover

Chassis 14 in. x 2 1/2 in. deep x 8 in. wide

V/Panel 14 in. x 2 1/2 in.

- | | |
|-----|----------------------------|
| C1 | .01 μF |
| C2 | .1 μF |
| C3 | 25 v. x 25 μF Electrolytic |
| C4 | .1 μF |
| C5 | 8 μF Electrolytic 350 v. |
| C6 | .1 μF |
| C7 | .1 μF |
| C8 | .1 μF |
| C9 | .1 μF |
| C10 | 8 μF Electrolytic 350 v. |
| C11 | 16 μF Electrolytic 350 v. |
| C12 | 16 μF Electrolytic 350 v. |
| C13 | .1 μF 500 v. working |
| CH1 | 10H 70 mA. |
| CH2 | 10H 40 mA. |

RADIO CONSTRUCTOR

Say you have a 3 ohm speaker then work out as follows:

Square root of

$$\frac{10,000}{3} = 3,333 = \text{approx. } 58 \text{ to } 1.$$

See separate sheet for valve holder connections, and voltage analysis of all stages.

Constructional details:—

The chassis is split up into individual assemblies and it is possible to complete each section as is convenient, and allowing a final assembly without any possible doubt.

Valve Panel:—

Size 14 in. x 2½ in. 7 ¼ in. holes are drilled or punched into this strip, being spaced equidistant from the centre. Mount the six octal valve holders, with the locating slots to the front. Place a soldering tag under fixing nut of all valve holders, nearest to pin No. 1. This is to earth the metallising around the input and phase inverter valves, and metal case of the OZ4 rectifier (if used). The earth tags are also used to earth pin No. 2 on all valves (except rectifier) this being the return path of filament circuit.

The last hole (i.e. to the right from the front), is for mounting the 16+16 µF

electrolytic capacitor. This also has an earth tag, as although the capacitor can be metal it is usually isolated, so make sure and earth the negative connection. Now fix the two side brackets, and that completes the assembly of the valve panel.

Next item is to drill the chassis proper.

Spot off for the mains transformer, smoothing chokes, input and output sockets, mains input and volume control. The sketches and photographs should not leave any doubt as to position of components. When these items are assembled, get valve panel, mount the valves, and check position of holes for grid leads, taking a line direct from grids to chassis. Dimensions given are approximate, and rests entirely on valve mounting. The same applies to holes under the panel used for connections to component panel. When the holes are drilled—mount the valve panel, and leave this until the next operation has been completed.

The main item is the component panel, the size as used being 6½ in. x 2¼ in. and carrying 17 pairs of tags.

A soldering iron is now required, and resistors and capacitors should be wired to tag board in the order shown on the sketch. Take care to clean all wires by scraping, tinning them before cutting to length required. Make firm clean soldered points,

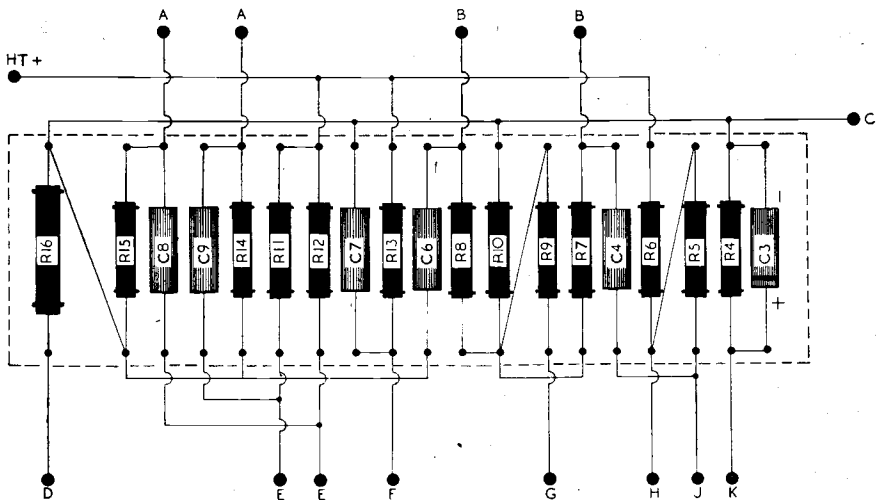

Sketch showing wiring of resistor and capacitor tag-board. External connections are as follows:—

- | | | | |
|------|------------------------------------|----|-------------------------|
| A—A: | Grids VT52 | F: | Screens VR56 |
| B—B: | Grids VR56 | G: | Cathodes VR56 |
| C: | To volume control and input socket | H: | Feed back capacitor (+) |
| D: | Cathodes VT52 | J: | Anode VR55 |
| E—E: | Anodes VR56 | K: | Cathode VR55 |

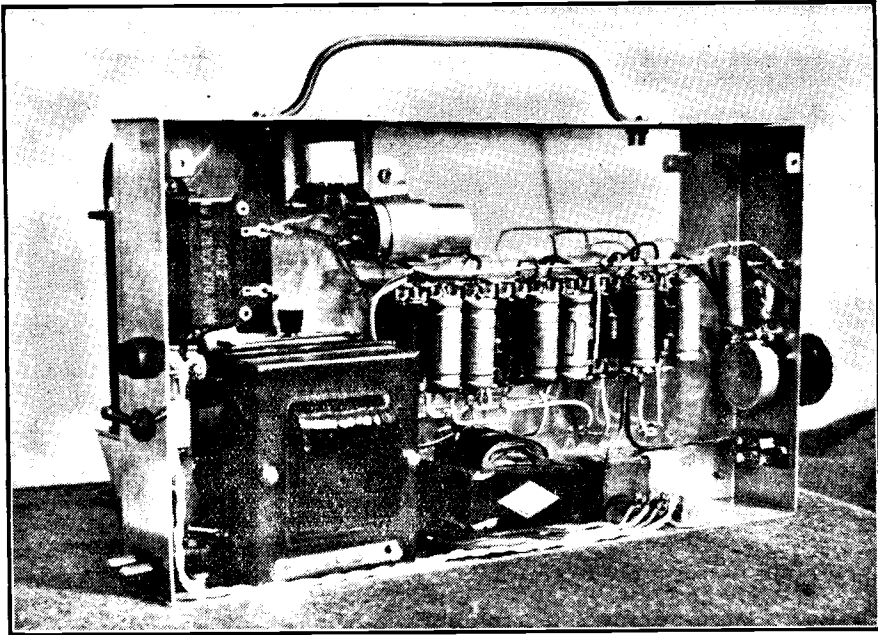

Rear view of amplifier with back removed

twisting the wires round the tags, not relying on the solder for mechanical strength.

Next a small quantity of 22 s.w.g. tinned copper wire and sleeving, or some of the .028 plastic covered bell wire is cut to make the links that are required between the various components. Again consult the sketch.

It is important that the earth line should run on the component panel as in the sketch, or eddy currents circulate through the chassis causing hum troubles. Now allow about 6 in. length of wire for those going through chassis to valve panel. When these are all complete, mount the component panel on the chassis (using 2 x 1/2 in. spacers behind panel) and push connecting leads through their respective holes in the chassis (see photographs). Carefully check when connecting to the valve holders. All No. 7 pins on valve holders (except rectifier valve) are linked and taken to 6.3 v. winding on mains transformer, other links being Pins 4-5 and 8 on input valve. These are all connected together and go to cathode resistor R4.

The phase inverter valve holders have a link between Pins 5 and 8 on both valves—then connected together and taken to R9.

A further link is between both No. 4 pins of the phase inverters and taken to R13 and C7.

The output valves have a link across the No. 8 pins and this is taken to R16.

The only other link is from Pin No. 8 on rectifier valve to the positive terminal of 16 μ F capacitor and then through chassis to choke No. 1. The remaining connections are all single wires.

Now for the screened leads.

Three of these are required, and here are some hints on making a neat job of this.

Get the screened lead and with a fine point (a pair of compasses would do) unravel screening about 3/4 in. Twist this screening wire together, and then cut about 1/2 in. of insulation away from centre lead. You now have an easy means of soldering the screening and centre leads without damaging insulation. Repeat process the other end after checking length required, and connect centre lead to grid connection inside cap, and poke twisted end of screening through the small hole in the earthing clip of the top cap screen. Apply solder and trim the ends, and you have a really neat top cap lead.

For the rest of the wiring, the mains input, switch and transformer should be wired first, and then the rectifier filaments and anodes.

Be careful of insulation of all leads, owing to the voltages concerned.

RADIO CONSTRUCTOR

Next we have the smoothing circuit, to be followed by the output transformer and output socket. The earth lead of the $8 \mu\text{F}$ feed-back capacitor should be made now, allowing sufficient length to change over the leads if instability is present. Now wire up the input stage, and that should complete the whole job.

Testing:

Don't be too impatient:

Have a check over, lead by lead (crossing them off the diagram as you go) to make sure there are no mistakes. With everything correct, connect speaker, and then the mains and switch on. Filaments should glow almost immediately, and if you have a D.C. volt-meter this should be connected to centre tap of output transformer and earth. The reading should be round about 250 volts. Allow about 45 seconds and the volts should be there. If not switch off immediately and check H.T. line, checking this to ground, also continuity of chokes, output transformer, etc.

Assuming all is well after the initial warming up, turn volume control to maximum for check on instability.

This is present as a high pitched howl, and method previously mentioned should be taken to correct it.

After this, listen for hum.

With the back off and volume control (do not have any external connection to input plug) flat out, hum should be audible, and

VOLTAGE ANALYSIS

		Volts
Input Valve	Anode	40
	Cathode	1.4
Phase Inverters	Anode	120
	Screen	60
	Cathode	30
Output Valves	Anode	240
	Screen	240
	Cathode	18
Rectifier	Anode (A/C)	250
	Cathode	250

(Points mentioned to Chassis)
230 v. A/C Input

when the hand is placed within 6 in. of component panel, should show a marked increase. Place back panel on chassis—all hum should disappear, and there should only be a slight hissing sound in the speaker.

Should you have trouble, make a careful check on all earth connections. It was not necessary to use external earth on the prototype model, the only trouble encountered being modulation hum, when on radio. The cure was a $.1 \mu\text{F}$ capacitor (C15) from one side of mains to chassis, and is shown in the circuit diagram.

Finally, the protective grill: This was a problem, as perforated metal is not easy to obtain. However the solution was found in

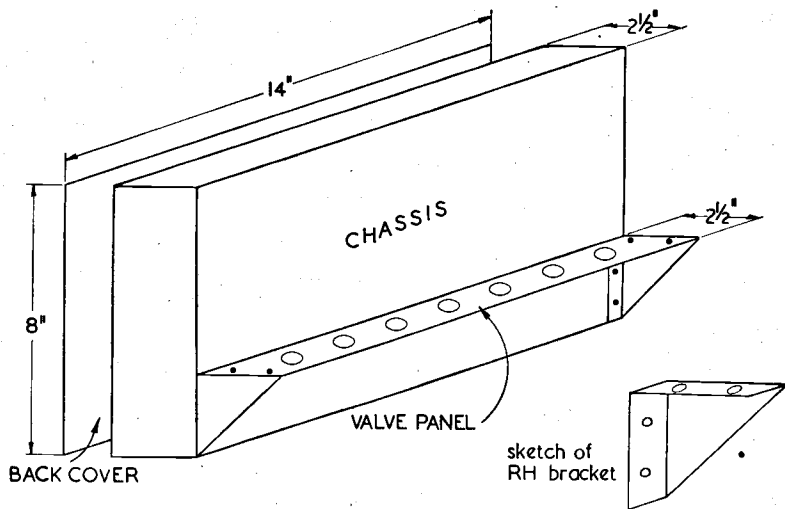

Sketch showing construction of metal work

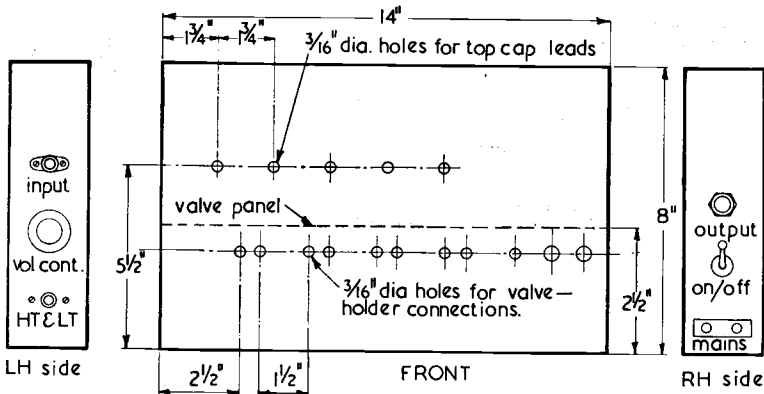

Main drilling dimensions for the main chassis

using 3/16 in. copper tube. The photographs show the final arrangement. A round file was used to cut in about 3/32 in. where the soldered joints are made. This makes the whole thing rigid and it is possible to lay the amplifier down without damage.

A further advantage is that of being able

to check volts, etc. on valve panel, should this be necessary.

No originality is claimed for the circuit, the lay-out and final details being the result of many weeks experimenting to produce a stable and easily constructed high quality amplifier.

Pin Connections For The Valves Used

VR55

Pin. No. 1	Earth
2	Earth (Fil)
3	Anode
4	Diode to Cathode
5	Diode to Cathode
6	Blank
7	Filament
8	Cathode
T/Cap	Grid

VR56

Pin No. 1	Earth
2	Earth (Fil)
3	Anode
4	Screen
5	Suppressor
6	Blank
7	Filament
8	Cathode
T/Cap	Grid

VT52

Pin No. 1	Earth
2	Earth (Fil)
3	Anode
4	Screen
5	Blank
6	Blank
7	Filament
8	Cathode
T/Cap	Grid

6X5G

Pin No. 1	Blank
2	Filament
3	Anode
4	Blank
5	Anode
6	Blank
7	Filament
8	Cathode

OZ4

Pin No. 1	Earth
2	Blank
3	Anode
4	Blank
5	Anode
6	Blank
7	Blank
8	Cathode

(N.B.—Pins are numbered reading in a clockwise direction from the spigot when viewed from underneath.)

Radio Conditions

A Survey of Conditions on the Broadcast Bands
By ISWL/G211 (Bristol). All times in GMT

SOME very good signals have been heard here in the West of England over the past month. Conditions were much better at the end of August dropping off somewhat afterwards up to the time of writing. We should much appreciate reports on conditions in your locality so that we can make out a more complete survey for this column. Address all correspondence to ISWL/G211, c/o "Radio Constructor" to reach me by the 10th of the month or earlier.

This is how we found things in Bristol over the past month: FZI Brazzaville was heard R9 QSA5 at 1855 on its 11970 kcs. channel with the usual slight flutter QSB. This station makes an excellent marker for dropping down on to the 25 metre Band. TPB7 Paris was another very good signal on 11885 kcs. at 1900, GRF Daventry was R9 QSA4 with CW QRM at 1920 on 12095 kcs. The 31 metre Band provided several good strong signals, Leipsig on 9730 kcs. heard at R8 though suffered some bad QSB distortion at 1930. Busto Arsizio Italy on its 9630 kcs. channel has been excellent at 2000. Radio Andorra on 5980 kcs. seems to be the most reliable station from Europe just now operating nightly at 2100-2300. The 6 Mcs. Band wants a lot of "cleaning up" as does 11 Mcs. QRM on 6 Mcs. appears to get heavier in the evenings with a few nice CW signals adding to the confusion!

11 Mcs. over the past month has not produced a great deal of DX signals of 100 per cent. listening value. From Canada CKNC 17820 kcs. has been R8-9 QSA5 most evenings around 1800. TAP Ankara Turkey was R9 with very good quality at 2030 on 9465 kcs. The Vatican Radio HVJ 9660 kcs. was heard with very strong QRK at 1400. United Nations station in Geneva was R8 at 1930 on 9515 kcs. Best "Aussie" was VLA6 15200 kcs. at 0615-0700 R7-8 with BC to the British Isles. ETA Addis Ababa Ethiopia has been heard R8 on approx. 15065 kcs. with some CW QRM. PRL7 Rio de Janeiro 9720 kcs. has been R8 QSA5. The RX used here is an S20 with a $\frac{1}{2}$ Wave Window Aerial running N.N.W.-S.S.E. and about 35 ft. high. All reception on speaker. So until next month . . . 73 and good listening.

DX PREDICTION FOR MID-SEPTEMBER TO MID-OCTOBER

(7 and 14 Mcs. through courtesy of Geoff. Hutson, G6GH. 28 and 60 Mcs. with acknowledgement to Denis Heightman, G6DH).

7 Mcs. Conditions

0500-0700—W1, ZL.

2000-2100—ZS, VK.

2300-2400—W1.

14 Mcs. Conditions

0600-0700—W6, W7, VK, ZL.

0800—VK, ZL, J.

1400—VK, J.

1500—VK, VS1, 6, C.

1600-1700—W6, 7, VU, VS7, ZS.

1800-1900—ZS, ZE, VQ2, 3, 4, 5, 8.

2000-2400—W, PY, LU, VP2, 4.

28 Mcs. Conditions

This period marks the change from summer to winter conditions. F2 MUF will increase, giving reliable, strong signals from Africa most of the day with peaks morning and evening. The higher F2 MUF will result in a shortening of skip and signals from 2000 miles (i.e. Middle East) will be received most of the day).

Signal paths to N. of E. and W. will increase in reliability, but there will be some interruptions due to ionospheric storms. Commencing around 0700 GMT, Asian and Oceanic paths will open with peaks at various times. VK and Far East will be good at 1200-1500. From 1000-1100 S. Americans should come in, followed by Central American and W. Indian signals. N. Americans will provide excellent signals on many days appearing from 1200 or earlier and remaining audible up to 2100. Pacific Coast W's and VE's should appear in late afternoon, peaking around 1800. ZL, VK and S. Pacific signals will be audible on good days over long path W.S.W. via S. America from 2200.

Sporadic E Europeans will become infrequent, but some European signals may be received by low angle rebound.

60 Mcs. Conditions

Short skip conditions will be infrequent but tropo conditions under settled weather will remain good up to 200 miles distance. The F2 MUF to the S. will peak around mid-day making possible occasional 50 Mcs. propagation to S. Africa (such as that on March 26th and 29th when PAoUN was received in Cape Town).

The Beginners One-valver

By John Clarke, ISWL/G10

(Several readers have expressed the view that the o-v-2 described in "Making a Start" was slightly too advanced for them. Here, then, is a receiver well within the capabilities of the rawest beginner.—Ed).

THE single valve receiver about to be described is capable, given favourable conditions and an efficient aerial/earth system, of receiving signals from all parts of the globe. It will make an ideal stand-by receiver for any station, and is recommended as a starting point for the newcomer to constructional work.

The Circuit

The aerial is coupled via a small capacitor C1 to the primary winding of the tuning indicator, as shown in Fig. 1. The secondary or grid winding of this coil is tuned to the frequency of the incoming signal by the bandset capacitor C2 and the bandspread capacitor C3, and the voltage developed across this coil is applied to the valve working as a leaky-grid or grid current detector. The Q of the circuit, and hence the sensitivity, is raised by the use of regeneration or reaction, R.F. being fed back from the anode to the grid, in the same phase as the current already flowing in the grid circuit, by the variable capacitor C4 and the reaction winding in series with it. The rectified output of the diode section (grid-filament) is amplified by the whole valve working as a triode, and appears across the anode load, in this case the headphones. Quite a straightforward

arrangement, in fact, but with one or two refinements, such as the inclusion of R3 and R2 to give smoother reaction and the provision of bandspread tuning, which make a world of difference to results, especially on the higher frequencies.

Before dealing with the actual construction, there are a few points in regard to the components, etc., which should be understood if the best results are to be obtained. It is not much good going to the trouble of collecting a few microvolts on the aerial, and then frittering them away in the receiver. So the first essential is that insulation must be adequate, and this means that first-class components only should be employed. This does not mean, though, that the cost need necessarily be high. The variable tuning capacitors must be of the air-dielectric type, employing a minimum of high grade insulation.

All fixed capacitors at R.F. potential, in this case all except C7, should be of the mica dielectric type, or the more recent silvered-mica or silvered-ceramic varieties. C7, which is used to decouple the H.T. battery when the internal resistance of the latter becomes high, can be either a Mansbridge type or the physically smaller electrolytic form. It is essential, though,

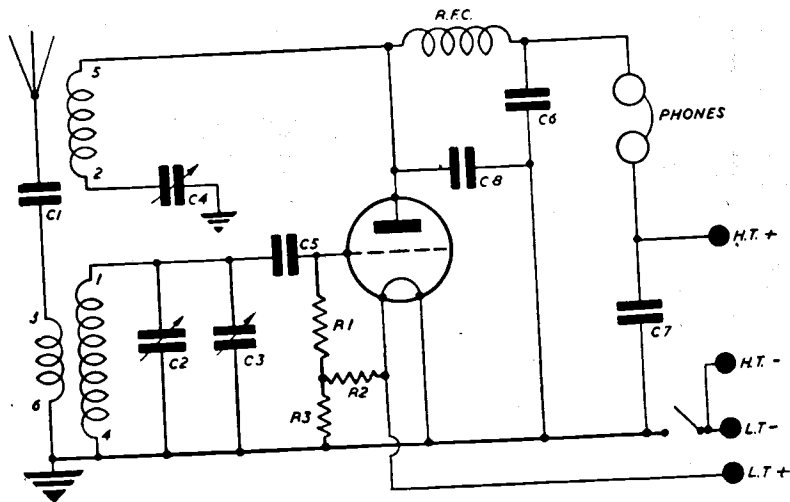

Fig. 1: Theoretical circuit of the beginner's one valver

RADIO CONSTRUCTOR

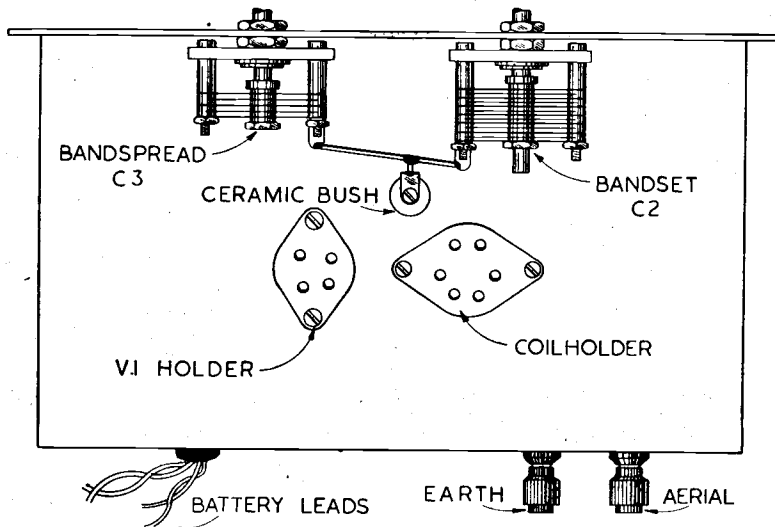

Fig. 2: Above chassis view showing disposition of components

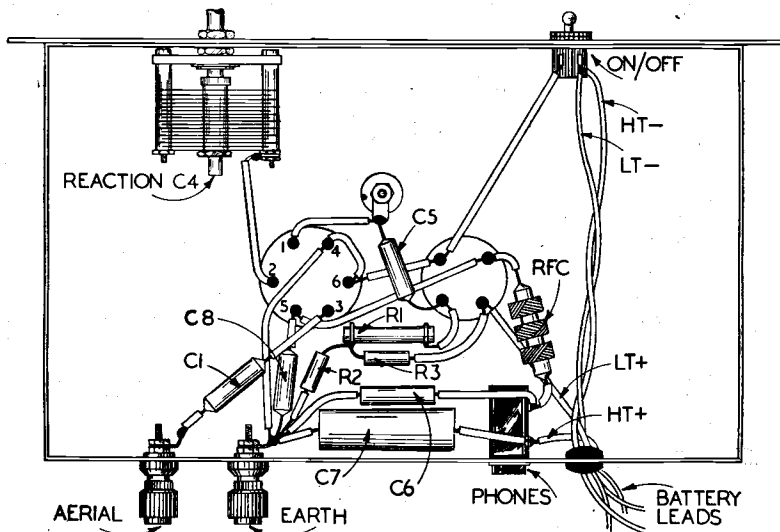

Fig. 3: Under chassis view showing wiring. Note that the aerial terminal must be insulated from the chassis, whereas the earth terminal is not

where an electrolytic capacitor is employed in this position, that the switch should break the H.T. battery as shown in the circuit diagram, as there will otherwise be a constant drain on the battery due to the leakage current which is normal to this form of capacitor.

The wattage rating of the three resistors

is not important, as the current passed is negligible. The reaction capacitor should be similar to those used for tuning, and should preferably be fitted with a reduction drive for more easy adjustment.

The tuning coils shown are the well-known 6-pin plug-in type. It is essential that good quality slow motion drives be

used, as nothing is more annoying than a drive which slips, or which suffers from "backlash," i.e., one which gives readings differing according to the direction of rotation. The power supplies consist of a standard 120 volt H.T. battery and 2 volt 45 AH accumulator.

Construction

The receiver is built on a chassis measuring 11in. x 6½in. x 2½in., with a panel 12in. x 9 in. high. Figs. 2 and 3 show the disposition of the components, the exact layout not being critical providing that all leads at R.F. potential are kept as short as possible, particularly the grid wiring. The latter should be of heavy gauge wire, preferably 16 swg tinned copper, so that it presents a low R.F. resistance, and also remains in position and so does not cause the calibration of the receiver to vary.

Operation

When the construction is finished, a

check should be made of the wiring. When satisfied that all is correct, a coil and the valve can be inserted in their respective holders. The valve used was a PM2HL but a similar triode would be satisfactory. Connect up to aerial, earth and batteries, plug in phones, and switch on. Next slowly rotate the reaction capacitor C4, starting from minimum capacity, until the receiver just oscillates. This is indicated by a hissing sound in the phones, and the receiver is most sensitive when it is on the verge of oscillation. Now slowly rotate the band-spread capacitor C3, adjusting the reaction control where necessary when a number of signals should be received. A log should be kept of the signals identified, with their dial readings, and after a little practice it will be found that the bandset capacitor C2 need only be set at certain points, and the intervening spaces covered by the band-spread capacitor C3. It should of course be remembered that reception conditions vary a lot, and over certain portions of the dial no signals may be heard, but providing that the reaction control works normally, and

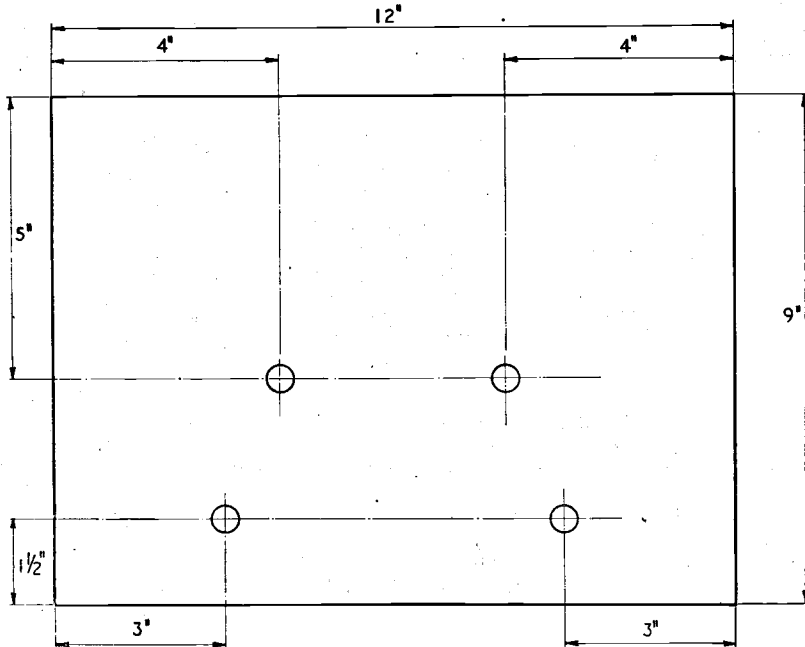

Fig. 4: Dimensions of the panel

connection of the aerial results in a "click" in the phones, the receiver may be taken as operating correctly at such times.

It may happen that "dead spots" occur, that is to say, at certain frequencies it will be found impossible to get the set to oscillate. This will almost certainly be due to the loading effect of the aerial on the coil, and can be remedied by either shortening the aerial physically, or by reducing it electrically by using a smaller capacitor C1. Another possible cause is an unsuitable R.F. choke, and the remedy in this case is replacement with a choke of another type.

Reaction, though present, may be uneven or fierce, indicated by the receiver going into oscillation with a "plop," or by the setting of the reaction capacitor being different when going into oscillation than when coming out. The combination C5-R1 will affect this, and slightly different values should be tried, lowering C5 and/or raising R1. A higher value for C8 can also be experimented with.

Component List

C1	50 $\mu\mu\text{F}$	Aerial Series
C2	150 $\mu\mu\text{F}$	Bandset Tuning
C3	20 $\mu\mu\text{F}$	Bandspread Tuning
C4	250 $\mu\mu\text{F}$	Reaction
C5	100 $\mu\mu\text{F}$	V1 Grid
C6	100 $\mu\mu\text{F}$	R.F. Bypass
C7	2.0 μF	H.T. Decoupling
C8	50 $\mu\mu\text{F}$	R.F. Bypass
R1	4 megohms	Grid Leak
R2 & 3	200 ohms	Filament Potentiometer

Coils 6-pin plug-in type

Slow Motion Drives

R.F. Choke

Headphones

Phone jack

Chassis: 10½ in. x 6 in. x 2½ in.

Panel: 12 in. x 9 in.

British 4-pin valve holder (ceramic)

6-pin ceramic coil holder

Aerial and Earth terminals

On/off toggle switch

Valve: PM2HL or similar

"Query Corner"

IN order to start this service, we have selected a number of enquiries from those which we receive regularly each month. As the magazine has to be prepared and sent to the printers well before the date of publication, it was impossible to deal with the letters received following our opening announcement last month in time for this issue. Don't forget that all enquiries will be answered by post regardless of whether or not they are printed in the magazine. It is also hoped that the post enquiries will deal with the subject in greater detail as paper shortage necessitates abridged answers in the magazine.

Band Spreading

"I am thinking of building a straight short-wave receiver, and would like to know what, in your opinion, is the best method of band spreading."

J. EDWARDS, Leeds.

On short wave working, owing to the close frequency proximity of transmitters, and the large frequency range which may be covered by a standard 0.00015 μF tuning capacitor, it is impossible to avoid passing over many stations when rotating the tuning dial unless some form of band spreading is employed. Band spreading systems

may be divided into two types, electrical and mechanical. The mechanical type normally takes the form of a reduction gear drive with special spring loaded gears to prevent back lash. The electrical method may take several forms, one of the most popular of which is the use of a low value capacitor connected across the main tuning capacitor. In order that any system of band spreading should be effective it is essential that the components in the RF side of the receiver are rigidly mounted. This normally necessitates a strong chassis with a well supported front panel, and sturdy straight connecting leads. These factors assist in preventing frequency drift, and thus help to hold the signal when it has been selected. There is much to be said for a really good mechanical band spreading system, but the associated gears and dial are expensive, and it is far better to use an electrical system rather than a poor mechanical one, suffering from backlash. Any reader who has experienced this maddening defect will appreciate this point.

In our opinion one of the best systems for the average short-wave enthusiast is to use a stop plate with ten or more positions on the spindle of the main tuning capacitor. A band spread capacitor is then employed

across the main capacitor and its value selected such that it just covers the frequency which is spanned by each position of the main capacitor. This scheme provides a simple yet efficient band spread.

AF Stage for R.1155

"I have an ex-R.A.F. R.1155 receiver, which I am using at present with a single output stage and power supply. I would like to use some sort of negative feed back in the audio stage and if possible make connections for using this part of the receiver in conjunction with a gramophone pick-up." L. GREEN, Maida Vale.

From your letter it is not apparent why you wish to use negative feed back, as this would make very little improvement in the tonal quality of the receiver, as, due to its high selectivity the audio frequency response is rather narrow. However, as you wish to use a pick-up with the receiver, we would suggest a two-stage amplifier with negative feed back to provide excellent quality when used with a pick-up, and at the same time function satisfactorily with the receiver.

The tone control is incorporated in the negative feed back line, a scheme which has been found to operate very satisfactorily. The total current drain of the amplifier is less than 50 mA. so that modifications will not be necessary to your power supply. The output transformer should be of such a ratio as to present the output valve with an effective load of 5,000 ohms. The input leads to the 6Q7 should be screened in order to prevent instability and hum. (Figure 1).

Local Superhet Oscillator

"I am enclosing a circuit of the H.F. stages of my all wave superhet receiver which I have recently constructed. The receiver fails to operate, although I have carefully checked all connections. The audio and intermediate frequency stages seem to be "live," but I cannot hear the familiar clicks when the aerial is connected."

M. SMITH, Torquay.

We have checked your circuit and found it to be correct, and are led to assume that the trouble lies with the frequency changer, the triode section does not appear to be oscillating. This fault may be checked by inserting a milliammeter in the grid or anode circuit at the points marked "X" on the circuit diagram. In either case, if the valve is working, a marked change should be visible in the meter reading, when the grid of the oscillator section is touched. If this is found to be the trouble, the fault may lie with one or other of the following causes: (a) Regeneration coil connected in the reverse direction to that which gives positive feed back; (b) Faulty valve—It is possible that a trace of air may have leaked into the valve envelope. This would not appreciably change the electrode current but it would cause excessive grid current to flow, thereby damping the tuned circuit and preventing the valve from oscillating; (c) One or other of the components may be faulty. The tests should be made in the order given whereupon the fault will be apparent. (Figure 2).

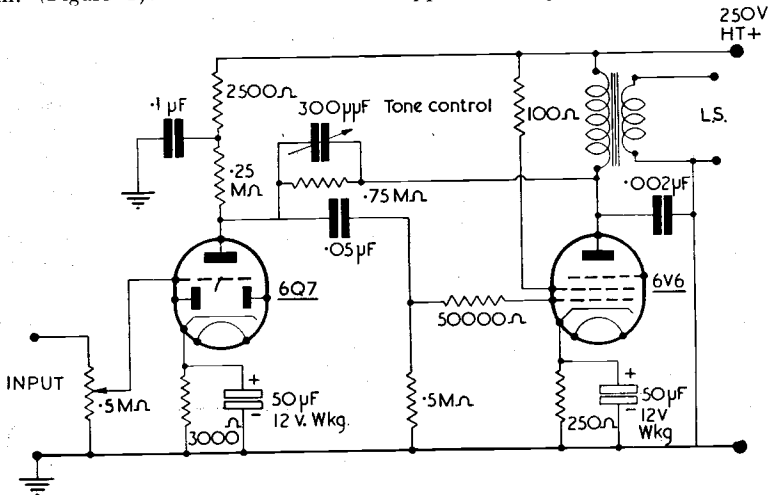

Fig. 1: AF stage for R.1155

AVC Time Constant

"I have a five valve commercial communication type receiver to which I have made several minor modifications. Recently I have noticed that when the AVC switch is in the "on" position, and a strong local signal being received, a kind of fading is apparent, this effect disappearing when the AVC is switched out."

L. MITCHELL, Oxford.

Your trouble appears to be due to the use of incorrect value for the time constant in the AVC system. This time constant should be high enough to smooth out the modulation, and yet, at the same time, provide a D.C. voltage which varies with the average value of the carrier as it fades.

In your receiver the time constant would seem to be too low, thus a short loud passage in the programme being received, produces an increase in the AVC voltage and hence a radiation in volume. This reduction will permit the control voltage to decrease again and the programme will return to its original volume level, thus producing the effect of fading or "fluttering" according to the type of programme. The time constant measured in seconds is given by

$$r = c (\mu F) \times R (M\sim)$$

and should be of the order of 0.2 seconds for a receiver of this type. The diagram shows typical values for the components in the AVC system and should serve as a guide in checking your receiver.

(Figure 3)

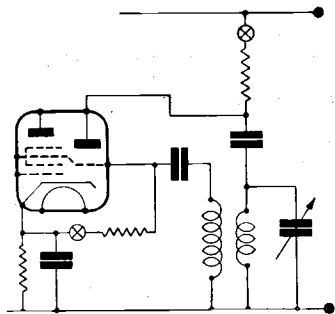

Fig. 2; Local Superhet Oscillator. "X" marks the spot!

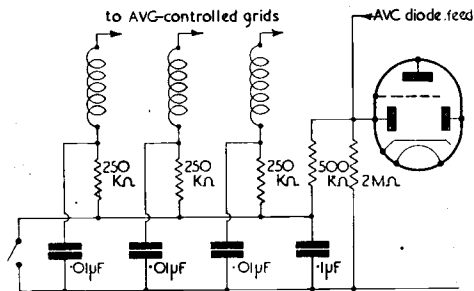

Fig. 3: AVC Time Constant

"Query Corner" Rules

- (1) A nominal fee of 1/- will be made for each query.
- (2) Queries on any subject relating to technical radio or electrical matters will be accepted, though it will not be possible to provide complete circuit diagrams for the more complex receivers, transmitters and the like.
- (3) Complete circuits of equipment may be submitted to us before construction is commenced. This will ensure that component values are correct and that the circuit is theoretically sound.
- (4) All queries will receive critical scrutiny and replies will be as comprehensive as possible.
- (5) Correspondence to be addressed to "Query Corner," Radio Constructor, 57 Maida Vale, Paddington, London, W.9.
- (6) A selection of those queries with the more general interest will be reproduced in these pages each month.

(EDITORIAL—Cont. from p.57)

fortunate in having at least one firm of metal workers who turn out excellent "tailor made" chassis, cabinets and metal work of all sorts to the specifications sent in by the customer. If the demand for this sort of construction increased, more would come into the field. So how about redesigning the VFO cum band switched Tx and endeavour to get it into a compact unit? We suggest the original model be made up roughly in plywood or old sheet metal and when the snags have been sorted out and as much space saved as well, patterns be sent away of the main foundation frame, unit panels, brackets, etc., to a metal worker who can produce something in black crackle or grey enamel which will look really good and give that professional touch which every craftsman seeks to produce.

A.C.G.

The Modulator for the "150 watt TX" has unfortunately had to be held over until next month.

Making a Start

No. 2 of a series of articles describing the progress of a newcomer to constructional work

By G3AKA

HAVING decided on the circuit to be used, the next step for our "raw beginner" was to start actual constructional work on the 0-v-2 battery-operated receiver. As we mentioned last month, when we described the circuit details, our 13-year old friend had never before attempted anything in the way of a "commercial appearance" receiver, previously relying on the inefficient and aptly named "breadboard" style. This type of layout does not lend itself readily to a neat and efficient-looking constructional effort; consisting of a wooden base and some form of panel—usually bakelite or ebonite, with all the component parts mounted on the wooden baseboard. Our protege had gone one better than the usual breadboard constructor by making his base in the form of a normal metal chassis, as readers will remember from last month's photo. However, the results were hardly any better and points we noted were the "messy" holes, inevitable in this type of construction, the long earth leads, due to being no common earthing point as is obtainable when using metal construction; the difficulty of making a neat looking job of mounting the components; the tendency of the wood to warp and to produce ugly looking crevices; and the very fact that the base looked what it is called—a breadboard!

There were, of course, other points such as poor soldering and connections and long wandering leads, but these faults are not restricted to breadboard layouts! They will be dealt with later on as we come to them.

The advantages of the metal-constructed receiver are many, chief of which may be said to be the rigidity of the finished article, the ability to make a neat layout and disposition of components, the fact that no awkward screening precautions (such as metal foil behind the panel) are necessary since the metal panel acts as an efficient screen, and the fact that the finished receiver has the appearance of being a piece of radio gear and not just a few components thrown together!

Many may feel, as our friend did, that working with metal presents difficulties too great to be overcome by the beginner. This is a fallacy indeed, since, having learnt one or two fundamentals, the working of metal is simplicity itself.

However, our friend, having been convinced that there was no way out but to rebuild his receiver on a steel chassis and panel, was confronted with his first practical query. He pointed out that the panel was considerably wider than the chassis and commented that surely they should line up. The answer is, of course, that it is usual practice to have the panel wider than the chassis so that the completed receiver may be housed in a cabinet at a later date, the flange created by the wider panel being convenient to bolt the receiver to the cabinet.

The first step, we told our beginner (his name is George, by the way) in any such constructional item is to bolt the chassis to the panel. This was accomplished by laying the panel on the bench, resting the chassis on the panel and marking the profile of the chassis on the panel with a pencil line. Two points to note here. Firstly, use a soft pencil as this will not damage the surface of the metal and can be easily erased and secondly let the panel come about $1/16$ in. below the bottom of the chassis. This has the effect, when bolted into position, of giving the receiver a slight tip from front to rear. It ensures that the panel does, in fact, cover entirely the front portion of the chassis. A front view which shows part of the chassis peering from underneath the lower edge of the panel looks untidy.

Having made the pencil outline of the chassis, the next step was to drill the fixing holes in the panel. These were made $\frac{1}{8}$ in. in from the edges and spaced $1\frac{1}{2}$ in. apart (two at each end) in a central position. The chassis sub-space, by the way, was $2\frac{1}{2}$ in. The problem of what size to use in the way of bolts came up and we recommended 4BA as being strong enough. When marking out the centres for these four holes it was noticed that the pencil marks were, in some lights, rather indistinct. To improve matters we substituted the pencil by a scriber, in our case a pair of ordinary "dividers" which had been discarded by one of our draughtsmen. They certainly make a lot of difference, though care must be taken not to mark the metal too much. After marking out, we showed our beginner how to use the "centre punch" to give the drill a start.

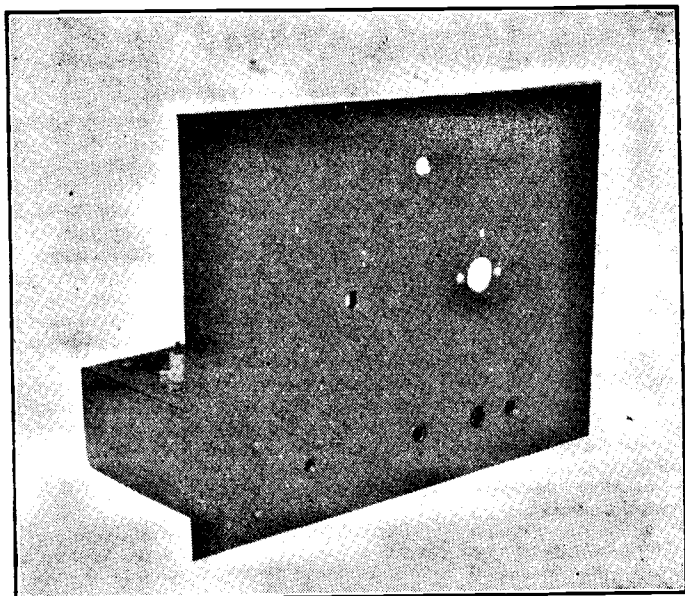

Front view: Top hole is for pilot indicator. Central holes are for fitting slow motion drives. Holes along bottom of panel are for reaction (with epicyclic drive), volume control, switch and phone jack.

Immediately George started his first drilling operations we saw that he was in trouble. The drill was slipping, progress was painfully slow and George seemed to be making really hard work of it all! If no one had been present he would probably have decided there and then to revert to his breadboards. As it happened he had the guidance and was soon drilling with the confidence of an old hand. What was wrong? There were three main faults with his approach to the operation, and faults that must be very commonplace with other beginners. In the first place our friend did not know the importance of balance. He had his feet together and this contributed something to the difficulties. Secondly he was not holding the drill vertical—most essential. Thirdly, being of rather diminutive size, the bench was much too high for him consistent with comfortable working. We cured this by giving him a box to stand on. From this we gather three important fundamentals to easy drilling. (1) Keep your feet apart, to give you balance. (2) Keep the drill upright and (3) Make sure that the work is at the right height for easy drilling. Observation of these points may well make all the difference to effortless working.

Having drilled the four holes in the panel, the centres were marked through on the chassis and the operation repeated. When all eight holes were completed we told George to clean up the burrs. He straightway asked for a file! Now by using a file to clean up burrs on small holes is

asking for trouble as it is so very easy to slip and so mark the metal badly. So we produced a drill (anything larger than about $\frac{1}{16}$ in. will do) and showed how easy it was to insert the drill point into the burred side of the small hole and give it a small twist. The burr came off nicely, leaving a clean hole. Having de-burred, the chassis and panel were bolted together with standard 4BA bolts.

Now the next problem was to start drilling some of the larger holes. George was perfectly willing to go right ahead drilling holes here, there and everywhere. In practise this may have worked out, but it is rather doubtful. So we proceeded to put him in possession of the facts.

The only way to make sure your layout is OK is to get together all the large components, such as the tuning capacitors, valves and coils, and move them around on the chassis until the best possible positions have been found. This means that components should be placed in such a way as to give the shortest possible leads, especially grid leads, consistent with a reasonably symmetrical layout. This operation is aptly termed "playing chess," and it will be obvious that a knowledge of the basic theory is necessary in order to follow the theoretical circuit diagram. Earth returns can be ignored in this process as they take care of themselves in the wiring up. The important ones to watch are those carrying R.F. currents (that is to say those leads in the aerial and grid circuits).

A great number of constructors are

puzzled by the fact that, though the manufacturers quote a given frequency range for their coils, with a given value of tuning capacitor, the actual ranges covered when the receiver has been completed are not quite the same. This is especially noticed on the higher frequency ranges, and coils stated to go down to 9 metres seem to go no lower than, say, 15. The reason for this is because manufacturers of coils give the ranges under the assumption that the "stray capacitance" in a given circuit is so many μF 's. If this amount of stray capacitance is greater than allowed for by the manufacturers calculations then the coils will tune to lower frequencies. In other words the strays are in effect in parallel with the tuning capacitor, and their value is thus added to it. So it will be clearly seen that strays are to be cut down to a minimum if maximum efficiency is to be obtained. That is why grid leads must be as short as possible.

To any constructor we suggest that patience must be exercised in the initial stages of making a set. Spend several hours planning it out if necessary—the finished result will well repay the time spent.

Well, eventually our 0-v-2 took shape and, having decided on the layout, work was commenced on the valve holes. The valves were to be arranged right along the rear of the chassis, as will be seen from the photo. Right to left we have Detector, 1st Audio and Output.

A centre line, in pencil, was marked off along the rear—1in. from the back, and cross centres marked off at $1\frac{1}{2}$ in. and $3\frac{1}{2}$ in. from the left and one at $1\frac{1}{2}$ in. from the right hand corner. For actually cutting the holes we used a chassis cutter of the punch-and-die variety, $1\frac{1}{2}$ in. diameter. These are readily available from various radio dealers. It was necessary to drill a $\frac{3}{8}$ in. dia. hole through each centre to accommodate the bolt on the chassis cutter. When these large holes had been cut, the valve holders were placed in position and then the fixing holes were marked through and drilled.

Having disposed of the valve holders, our attention turned on fixing the coils. It was decided to mount them on stand-offs and so the four necessary small holes were drilled. Then, working with the circuit diagram, we found that three holes were needed to carry leads through the chassis from the coil-holder. A further hole was drilled, and can be seen in the photo, to provide an earth anchor tag. It must be emphasized that the reason we are using the horizontal type of plug-in coil is simply because they were already on hand. Any type of plug-in coil would be satisfactory, though, of course, the fixing procedure would be different.

Now we come to the panel. Firstly we

(Cont. at foot
of next page)

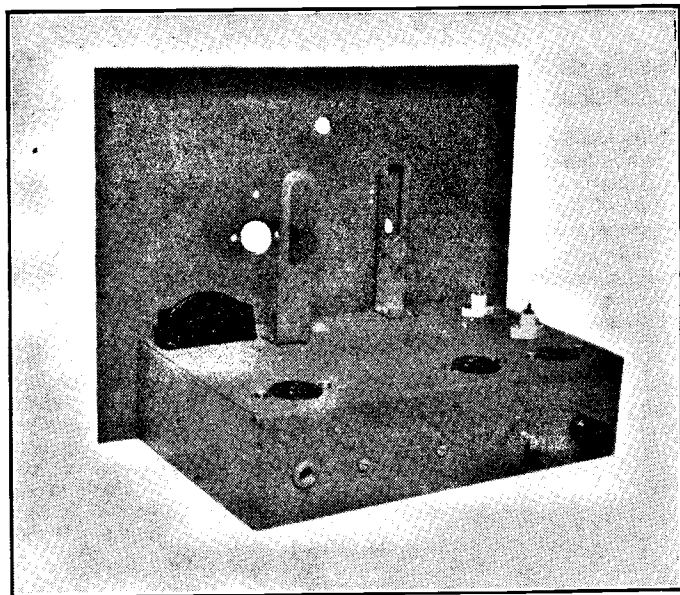

Rear view: The brackets are for mounting C2 and C3. The two stand-off insulators at extreme right are for mounting the coil holder (horizontal type). Valve holders are, left to right, Output, 1st Audio and Detector.

Add-on Unit for MCR-1

An Extra Audio Stage For This Popular "Surplus" Receiver

By R. C. Maltby

WISHING to add an amplifying stage to the MCR1 receiver, the writer successfully built the little unit to be described which should be of interest to other owners of this fascinating receiver who wish for more "punch."

Referring to Fig. 1, it will be observed that the valve chosen was a 1A5GT, a pentode power amplifier. The purpose of R1 and R2 is to bypass the HT current taken by the valve in order to prevent the filaments of the preceding valves being overloaded. Another point is that if the .5 Megohm gridleak was taken direct to the HT— line there would be 7.5 v. bias on the valve. Therefore the resistors R1 and R2 act as a potential divider to give the correct bias to the valve.

By using a 2½ in. speaker, it was possible to construct the add-on unit to dimensions in keeping with the main receiver, in fact the unit's cross-sectional dimensions are exactly the same. The four-pin plug and socket required to fit the unit to the main receiver are now available, so there will be no trouble in that direction.

One important point to note is that the receiver plus add-on unit will not work satisfactorily from batteries (i.e. 7.5 v. for the L.T.) as it is impossible to draw more

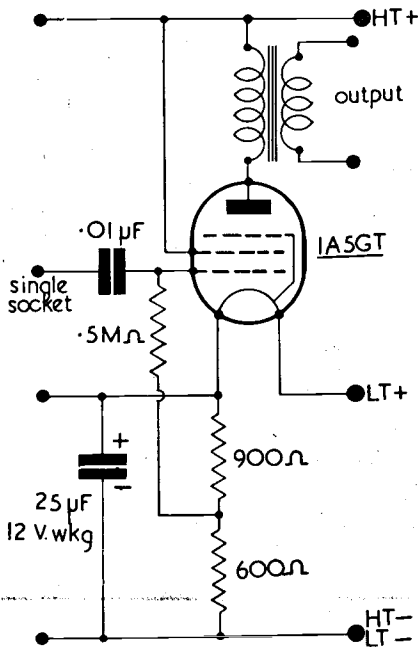

Fig. 1: R1 is 900Ω, R2 is 600Ω.

(MAKING A START—Cont. from p.79)

drilled the holes for the bandset and bandspread capacitor drives. Naturally this again depends upon the type of drive used.

The next job was the lower section of the panel. The four holes to be seen on the photo are, reading left to right, for reaction (using an epicyclic drive), audio volume control, on/off switch and phone jack. These were drilled through the panel first then marked through to the chassis. The holes come midway in the chassis sub-space, and their sizes are respectively 5/16in., 3/8in., 1/2in. and 1/2in. dia. One small hole to take a 4BA bolt is needed 3/8in. below the reaction drive hole to fix the drive. Finally one 3/8in. dia. hole in the centre of the panel to take a pilot indicator completed the panel drilling.

Reverting to the chassis we then drilled the holes and mounted the brackets for

supporting the variables. There are three of these: two above chassis for the bandset and bandspread capacitors and one under the chassis for the reaction variable. The fuseholder was then mounted and can be seen in position by the bandset capacitor mounting bracket. Four holes were needed, two for fixing and two to accommodate the leads. Oh, yes, and there was also a hole, fitted with a grommet, for taking the leads up to the pilot indicator. The final stage of the drilling operations consisted of fixing the aerial and earth terminals, mounting the L.F. transformer and making a hole large enough to take all the battery leads. These five holes can be seen at the back of the chassis. Other holes will be needed, when wiring up, for the purpose of fixing mounting anchors, etc., and will be dealt with next time.

NEXT MONTH: Wiring Up

than the 7.5 v. from the battery. If, however the power pack supplied with the receiver is used this trouble is overcome, since the extra voltage needed (to bring the total for the whole receiver to 9 v., with the six 1.5 v. valves) can be drawn from the power pack with only a slight fall in current.

When the unit has been finished remember that it **must** be connected to the main receiver before switching on the power pack. The point is that when the plug from the add-on unit is connected to the power pack, pins 1 and 2, which are connected together, bring the high capacitance low voltage electrolytic into circuit across the filament supply. If this capacitor discharged through the filaments of the 1A5GT it would most likely not do the valve a great deal of benefit!

The modification needed for the main set is very simple. All that is necessary is to insert a capacitor between the anode of the output valve and the extra socket which must be fitted to the panel. Thus the output transformer on the set acts as a choke; a choke-capacitance coupling is obtained. (See Fig. 2).

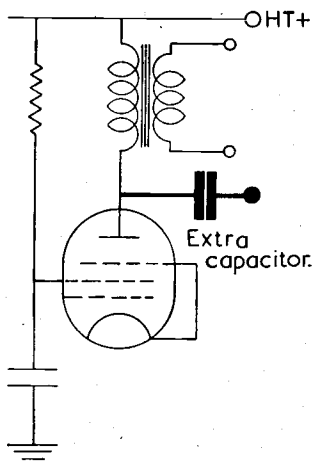

Fig. 2

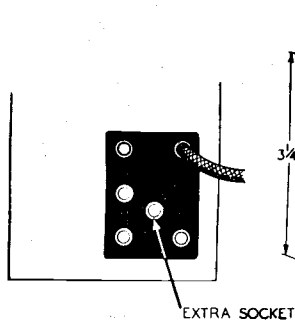

Fig. 3: Showing extra output socket on main receiver

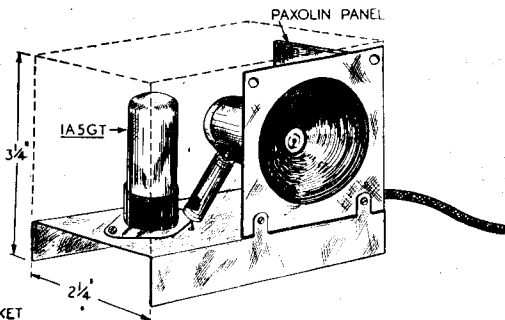

Fig. 4: Sketch of complete add-on unit

Trade Notes

TRADE NOTES

Clydesdale: The "Third List of ex-Government Electronic and Radio Equipment" has now been issued by this firm. It is a 68 page catalogue, well illustrated, containing a wide range of popular "surplus" gear. This catalogue is available to any reader who cares to apply to Messrs. Clydesdale Supply Co., Ltd., 2 Bridge Street, Glasgow, C.5.

Mullard: The Accounting Administration

of the Mullard Wireless Service Co. Ltd., has now returned from its wartime evacuation address at Oxted to Head Office, Century House, Shaftesbury Avenue, W.C.2. Telephone number is Gerrard 7777.

J. Bull: The latest list of war-surplus gear available from this firm, contains items particularly of interest to the transmitting amateur. Copies may be obtained from J. Bull (Ruislip) Ltd., 42-46 Windmill Hill, Ruislip Manor, Middlesex.

Book Reviews

RADIO OPERATING—QUESTIONS AND ANSWERS. A. R. Nilson & J. L. Hornung. 8th Edition. McGraw-Hill Publishing Co., Ltd., Aldwych House, London, W.C.2. 434 pp. 17s. 6d.

Primarily intended for professional radio operators, this book is nevertheless of great value to the radio amateur, both before and after obtaining his call. The book is set out in the form of questions and answers, and while the scope of these and the standards set are obviously greater than required by the amateur, many of his problems are encountered also by the commercial operator. The subject is covered thoroughly and involves quite a bit of theory, and it should certainly be studied by those who consider "operating" to be merely a matter of switching on and shouting into a microphone!

INTRODUCING RADIO RECEIVER SERVICING. By E. M. Squire. 144 pp. 2nd Edition. Sir Isaac Pitman & Sons Ltd., London. 7s. 6d. net.

This book has been designed to cater for newcomers to the servicing side of the radio industry, many of whom first made contact with radio as a career when in the services. It will also, in fact, be of great assistance to the average home constructor.

The reader is first taken on a general survey of a receiver, including power supplies, aerials and earths. He is next acquainted with the main components used, such as resistors, coils, capacitors, transformers and valves.

Then follow chapters on circuit diagrams and how to read them, the operation of a

typical receiver, providing power to the valves, and the radiogram. The remaining chapters deal with servicing equipment and how to use it, and tackling the first service job.

A point we liked very much is that throughout the book theory is linked with the practical application or effects of such theory. Altogether a most useful little book containing a surprising amount of information. C.W.O.

"CQ" Records

A new service for amateurs in the form of a CQ call Record has been started by Peach Studios, 15 Plumstead Road, Woolwich, S.E.18. A double-sided 5-inch record, playing time a little over one minute each side, of good quality, costs only 6s. and larger size discs are supplied at a similarly reasonable rate. A number of trailer needles are supplied with each disc.

For those amateurs who are unable to attend at the Studios, the words can be read for them by a member of the staff there.

A recording tested out has been found very satisfactory and contacts did not realise they were replying to a recorded voice until they were told. The durability of the record is of course dependent on the lightness of pick-up, type of needle used, etc., but at least 100 playbacks with good apparatus would be possible before signs of serious wear became evident. It is suggested each side should be made for a different band, say 40 and 20 metres.

The service should commend itself to those who wish to monitor, or who tire of making CQ calls.

KEMP RADIO BARGAINS

CONDENSERS, assorted tubular and mica .001 mfd to .5 mfd at least seven sizes 4/6 doz. Silver Mica 50 pfd 4½d. each; 200 pfd. 5d. each; .0005 mfd 1% 5½d. each. Mica .001 mfd min. 5d. each; .002 mfd 600v. 4½d. each; .005 mfd 1500v. 5½d. each; .01 mfd 2000v. 5½d. each. Tubular .05 mfd 1000v. 5d. each; .1 mfd 350v. 6d. each. Tubular (can type) .001 mfd 1000v. 5d. each; .02 mfd 750v. 6d. each; .25 mfd 350v. 6d. each; .5 mfd. 350v. 7d. each.

ELECTROLYTICS 8 mfd 500v. can type 3/3.

LINE CORD .3 amp (60 ohms per foot) 3 way 2/3 per yard.

PICK-UPS Cosmocord Acos GP10 with virtually unbreakable crystal 44/- including P.T.

MAINS TRANSFORMERS 350-0-350v. 75 mA. 5v. 2 amp, 6.3v. 2.5 amp 25/-.

Large selection of radio and electrical goods including valves. Let us have your enquiries.

Carriage extra under 30/-. C.O.D. over £1.

KEMP RADIO, BCM/KRAE, LONDON, W.C.1.

"You'll probably get it at

Smith's of Edgware Road

The Book on how to make it,
The Material to make it with,
The Components to put in it,
The Equipment to test it with,
The Cabinet to put it in.
(AND a fair deal!)

H. L. SMITH & CO. LTD.

287-9 EDGWARE ROAD, LONDON, W.2

Near Edgware Road Met. and Bakerloo
Phone PAD. 5891 :: Hours 9-6 (Thurs. 1 o/c)

PREMIER RADIO

MORRIS AND CO. (RADIO), LTD.

ALUMINIUM CHASSIS.—Substantially made of bright aluminium, with four sides, 10in. x 8in. x 2½in., 7/6; 12in. x 9in. x 2½in., 7/9; 16in. x 8in. x 2½in., 8/6; 20in. x 8in. x 2½in., 10/6; 22in. x 10in. x 2½in., 13/6.

SUPERSENSITIVE DOUBLE HEADPHONES.—Balanced armature with reed driven aluminium diaphragm. 60 ohms, 8/6.

ELECTROLYTIC CONDENSERS.—Miniature metal can type, 8 mfd. 500 v.w., 3/6; 16 mfd. 500 v.w., 4/6; 8x8 mfd. 500 v.w., 6/6; 50 mfd. 12 v., 1/6.

2-VALVE, SHORT WAVE BATTERY KIT.—A complete Kit of Parts for a 2-valve receiver, covering 15-600 metres, including valves, coils, drilled chassis, H.T. and L.T. dry batteries, to last approximately 6 to 12 months. A pair of Double Headphones and full instructions. Price £3/10/-. An Extra Coil can be supplied, covering 600-1900 metres at 4/-.
ROTARY TRANSFORMERS.—Input 12 v., output 180 v. 30 mA., 4 v. 2-3 A. with 19 volts input, output is 50 per cent. higher. May be used on D.C. mains as L.T. Charger. With small conversion could operate as D.C. Motor. Original cost over £5. Employ powerful ring magnet. Price 10/- each.

OUTPUT TRANSFORMERS.—A super production. By means of ingenious series-parallel arrangement, all windings are used at all times. Match any tube, single or push-pull to any voice coil 2-30 ohms. 7 watts, 22/6; 15 watts, 30/-; 30 watts, 49/6; 60 watts, 59/6.

OUR 1947 LIST IS NOW AVAILABLE. All enquiries must be accompanied by a 2½d. stamp.

BATTERY CHARGER KITS.—All incorporate metal rectifiers, input 200-250 v. A.C. 40/100 cycles.

To charge 2 v. accumulator at ½ amp.	Price
" 6 v. " 1 amp.	15/-
" 12 v. " 1 amp.	17/6
" 6 or 12 v. " 4 amp.	22/6

Complete with Variable resistance and meter £3/15/-
 To charge 6 or 12 v. Accumulator at 6 amps.
 ditto £5

H.T. ELIMINATOR AND TRICKLE CHARGER KIT.—Consists of a complete kit of parts to construct an H.T. Eliminator with an output of 120 v. at 20 mA. and provision for trickle charging a 2 v. accumulator. Two metal rectifiers are employed. With circuit, price 30/-.

RADIOGRAM CABINETS.—Dignified appearance and good workmanship. Size 34½in. high, 19 in. deep, 36in. wide. Send for illustration. Cabinet only, £26. With Electric Motor and Pick-up, £32/16/-.

ROTARY TRANSFORMERS.—Size only 7in. by 4½in. diameter. With 6 v. input; output 200 v. 50 mA. With 12 v. input; output 400 v. 80 mA. Price 20/-

ROTARY TRANSFORMERS.—With 12 v. input; output 600 v. 250 mA. With 6 v. input; output 280 v. 250 mA., Price £3.

ALL POST ORDERS TO: Jubilee Works, 167, Lower Clapton Road, London, E.5. (Amherst 4723.)

CALLERS TO: 169, Fleet Street, E.C.4. (Central 2833.)

**D
E
N
C
O**

TECHNICAL BULLETIN No. 1

OBTAIN YOUR COPY, NOW, FROM OUR NEAREST APPROVED STOCKISTS (or direct in case of difficulty)

CONTAINS TEN LARGE PAGES ON:—

- (1) COMPLETE TECHNICAL DATA ON THE MAXI-Q RANGE OF COILS.
- (2) DETAILED DESIGNS AND CIRCUITS FOR HIGH PERFORMANCE SUPERHET, T.R.F., AND VHF CONVERTOR.
- (3) OTHER USEFUL INFORMATION ON THE APPLICATION OF MAXI-Q COILS. PRICE 3/-

It is our intention to publish, from time to time, similar bulletins on our other products.

You can now obtain good delivery of all DENCO components from our stockists.

OLD ROAD, CLACTON-ON-SEA, ESSEX

SMALL ADVERTISEMENTS

Readers' small advertisements will be accepted at 3d. per word, minimum charge 3/-. Trade advertisements will be accepted at 6d. per word, minimum charge 6/-. If a Box Number is required, an additional charge of 1/6 will be made. **Terms:** Cash with order. All copy must be in hand by the 10th of the month for insertion in the following month's issue.

PRIVATE

GW6AA going abroad is selling great quantity superb American and British receiving and transmitting apparatus, valves, crystals, components, etc. Mainly new. Examples: Canadian 1000/100/10 kcs. frequency standard £9 10s. National "One-Ten" Receiver, Power supply six sets coils, handbook £22 10s. Six brand new HK-254 valves £5 each. National HRO (U.S. Naval model RBJ) Receiver, power supply, special container with 9 coils, all rack-mounting, also table rack. Whole outfit complete with handbook, brand new, in maker's original cases £70. Two Hallicrafters HT-11A complete marine radio-telephone transmitter-receivers (807 Tx output) with power supplies, microphones, earphones, handbook £25 each. Mullard B-100 Oscilloscope £9 10s. Recent National NC100XA Receiver, perfect condition, crystal filter, noise limiter, "S" meter, power supply, speaker, handbook, complete £55. Marconi CR100 Receiver (not junked model) perfect, in grey case £30. Two type 58 Canadian Transmitter-Receiver, complete with headphones, microphones, power supplies, handbooks, aerials, etc. Brand new, £8 10s. each. Three American TBY U.H.F. transmitter-receivers 28-80 Mcs. continuous, with headphones, microphones, aerials, keys, handbook, calibration charts, brand new, £12 10s. each. Superbly engineered jobs. International Marine IMR-20 Communication Receiver 2 R.F. stages, for battery operation. Perfect. Just re-aligned by maker £15 10s. (complete with speaker and handbook). Nine brand new HRO coils £4 per unit. Hunts 1947 Resistance-Capacity Bridge Model CRB, brand new, cost £18 18s., sell £14 10s. Two brand

new Mortley-Sprague H.T. Generator Sets, Motor 24v. D.C., coupled on bed-plate to generator. Output variable 450-1700 v. at 150 mA. Unused, with original laboratory test certificates. Cost £60 each. Accept £30. Superb brand new modulator P.P. 807's. Rack mounting, complete two heavy power supplies, a real B.B.C. job, professionally made. Details. Much other equipment too varied to advertise. Lists free. GW6AA, "The Flagstaff," Colwyn Bay, Wales.

GRAM MOTOR DC or AC/DC wanted urgently. Offers to Box 102.

TRADE

QSL's and G.P.O. approved log books, samples free, from Atkinson Bros., Printers, Elland.

AMATEUR Radio Specialists. Send 2d. stamp for our Monthly Bulletin. Hallicrafters, National, Eddystone, Labgear, Berrys, Q.Max, Radiocraft, RX, TX parts, meters, etc. Johnsons (Radio), Macclesfield. Dept. C.

"**These You Can Hear.**" A quality production, on art paper throughout, and lavishly illustrated, for the beginner to Broadcast Station listening. Price 2/3 post-paid, or 2/- from local booksellers.

Listener Reporting Pads. 50 printed report sheets for the compilation of really useful reception reports. With card cover and full instructions. Price 2/6 post-paid.

AMALGAMATED SHORT WAVE PRESS LTD
57 Maida Vale, Paddington, London, W9
G2UK * G3AKA * G2ATV

SHORT WAVE (HULL) RADIO G5GX.

RECEIVER KITS

- 2 Valve O.V.1. Bandsread tuning, plug in coils, 9-200 metres, Pentode output. Price, less cabinet and batteries **£5 10s.**
- 4 Valve 1. (Tuned) V2 Bandsread tuning 9-200 metres. Black crackle steel cabinet. Price, less batteries and speaker **£12 12s.**

TRANSMITTER KITS

- 10 watt C.W. Tx with Xtal and coils for 160-80-40-20, **£11 0s.**
- 25/50 watt C.W. Tx with standard panel, meter, drilled chassis, Xtal and coil for one band, all components and valves, **£19 10s.**

Further details supplied on request.

SHORT WAVE (HULL) RADIO

30/32, PRINCE'S AVENUE
Phone 7168

METAL WORK *with a Difference!*

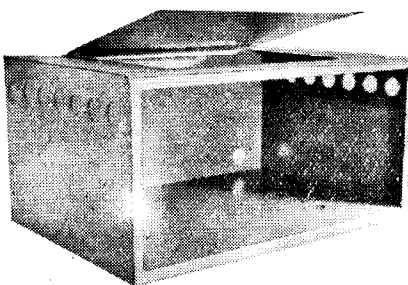

This is an example of gear which can be made to **YOUR OWN** dimensions and layout.

For full details and address of nearest agent, contact—

L. J. PHILPOTT (G4BI)

(E. J. PHILPOTT)

Chapman St., Loughborough Tel. 2864