

35% reader discount on new Basic concept

ELECTRONICS WORLD

Austria Asch. 66.00
Denmark DKr. 67.00
Germany DM 15.00
Greece Dra. 1100.00
Holland Dfl. 11.75
Italy L. 8800.00
Malta Lm. 1.55
IR £3.30
Singapore S\$7.50
Spain Pts. 850
USA \$5.95

INCORPORATING WIRELESS WORLD

A REED BUSINESS PUBLICATION
SOR DISTRIBUTION

June 1997 £2.35

LOUDSPEAKERS EXPOSED

**Opto devices
and a new
light meter**

**Does RF
affect audio?**

**Designing
voltage
doubling psus**

**Double
balanced
mixers**

**Working
with VHDL**

**Error feedback
amp examples**

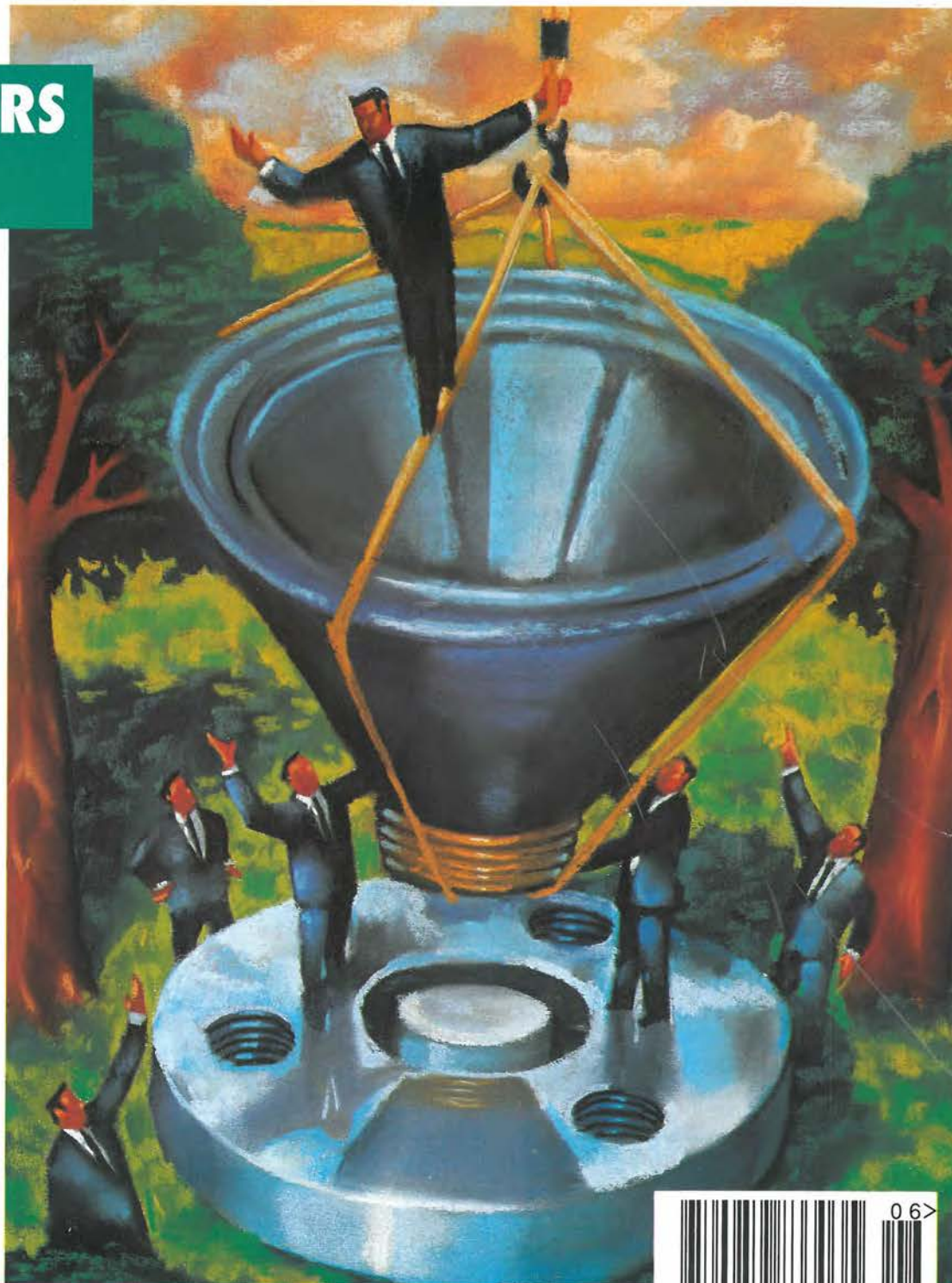

£100 discount – Kenwood oscilloscope



9 770959 833035

OLSON

For all your Power Distribution Olson offer a varied choice

OLSON Distribution Units

OLSON ELECTRONICS LIMITED

OLSON DISTRIBUTION PANELS FUSED, WITH R.F. FILTER AND R.C.D. PROTECTION

OLSON ELECTRONICS LIMITED

OLSON PANELS WITH RCD PROTECTIVE FUSE

OLSON ELECTRONICS LIMITED

OLSON 'The Rack Range' mains distribution panels for 19" rack mounting

OLSON ELECTRONICS LIMITED

OLSON Office Furniture Cable Management Manufactured to BS 6096

OLSON ELECTRONICS LIMITED

OLSON Mains Distribution Panels with Non Standard Sockets

OLSON ELECTRONICS LIMITED

OLSON FUSED SUPER SLIM

OLSON ELECTRONICS LIMITED

OLSON Earth Leakage Distribution Units

OLSON ELECTRONICS LIMITED

OLSON Distribution Units

OLSON ELECTRONICS LIMITED

OLSON PANELS WITH 10AMP CEE22/IEC SHUTTERED SOCKETS

OLSON ELECTRONICS LIMITED

OLSON 'The Rack Range' WITH AMERICAN SOCKETS 150V 15A

OLSON ELECTRONICS LIMITED

OLSON Mains Distribution Panels INTERNATIONAL RANGE

OLSON ELECTRONICS LIMITED

OLSON FUSED SUPER SLIM WITH ELECTRIC FUSE CONDUIT 150V 15A 1P&N 50/60HZ

OLSON ELECTRONICS LIMITED

OLSON DATA PROTECTOR

OLSON ELECTRONICS LIMITED

OLSON INDUSTRIAL RANGE 16 AMP 110V AND 240V TO BS 4343/IEC 309

OLSON ELECTRONICS LIMITED

OLSON Distribution Units

OLSON ELECTRONICS LIMITED

OLSON 19" FAN TRAYS

OLSON ELECTRONICS LIMITED

OLSON 'The Rack Range' CEE22/IEC SOCKETS

OLSON ELECTRONICS LIMITED

OLSON SERVICE PILLAR FOR THE OPEN-PLAN OFFICE

OLSON ELECTRONICS LIMITED

OLSON Distribution Units

OLSON ELECTRONICS LIMITED

Contents

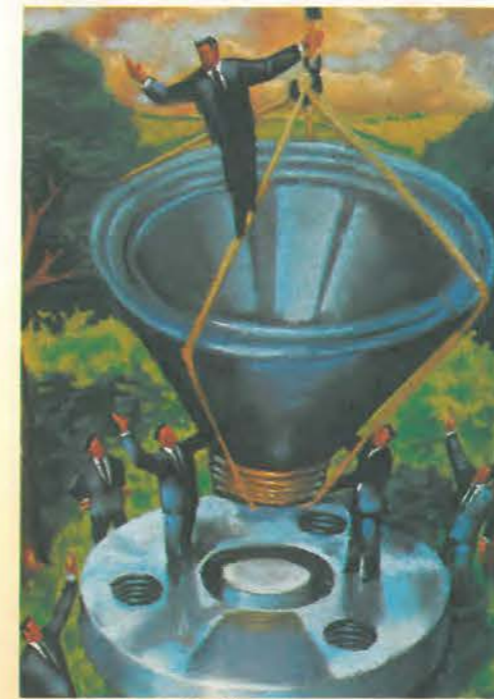

Cover - Hashim Akib

456 LOUDSPEAKERS EXPOSED

John Watkinson investigates why current loudspeaker designs are so backwards relative to the rest of the hi-fi chain.

466 A LOOK AT LIGHT

With the aid of his new light meter design, Ian Hickman looks at some of the more recent opto devices.

472 HANDS ON INTERNET

New search options, a directory for UK electronics companies and filter design CAD are this month's discoveries from Cyril Bateman.

476 ERROR FEEDBACK IN AUDIO POWER

William de Bruyn outlines three power amplifiers illustrating different ways of implementing error feedback.

480 RF EFFECTS ON AF

Could mysterious audio distortions be explained by pick-up from broadcast stations? Cyril Bateman investigates.

486 APPLYING DIODE MIXERS

Darren Conway describes how to get the best lanced diode mixers.

507 VOLTAGE DOUBLING

Look-up tables make designing a reliable voltage doubling power supply relatively simple, explains Ray Fautley.

517 CD JITTER BUG

Could jitter on signals between a cd player's transport and its d-to-a converter cause audible distortion? If it can, Chris Day's redesigned interface may be the answer.

519 PROGRAMMABLE LOGIC

The language for describing logic systems - VHDL - and turning schematics into code are Geoff Bostock's topics this month.

Regulars

443 COMMENT

Pre-election blues

444 NEWS

EMC laws difficult to enforce, Engineers lack lateral thinking, 56kbit modem.

450 RESEARCH NOTES

Thought control, New semiconductor technique, MW sun power, Super magnets.

493 LETTERS

Overload matters, Resistors in C, x-over distortion, phase quadrature.

498 CIRCUIT IDEAS

- Improved infrared proximity detector
- Power amp with adjustable impedance
- Two-wire remote control
- Ultra-simple oscillators
- Infinite impedance detector
- Offset source for op-amps
- Switch/latch/trigger

511 NEW PRODUCTS

The month's round-up of passive, active, instrumentation and computing products.

Special offers

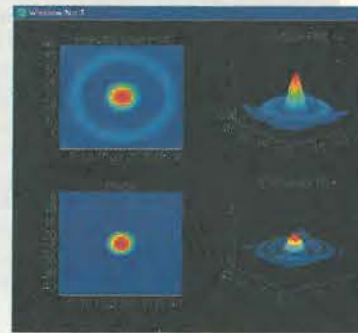

A new language for helping scientists and engineers to visualise data is available to Electronics World readers exclusively at discounts to 44% - see page 464.



This Kenwood 20MHz dual-trace oscilloscope is on offer to EW readers at just £319 - turn to page 471.



Cars with surround-sound systems based on flat-panel loudspeakers could appear this year - see page 444.

JULY ISSUE ON SALE 5 JUNE

OLSON ELECTRONICS LIMITED

FOUNTAYNE HOUSE, FOUNTAYNE RD., LONDON N15 4QL
TEL: 0181-885 2884 FAX: 0181-885 2496

June 1997 ELECTRONICS WORLD

World standard DAB setback

The worldwide adoption of the European Eureka 147 standard for DAB, or digital audio broadcasting, has taken a blow after a US decision to favour a satellite-based system.

To this aim, the US Federal Communications Commission (FCC) has auctioned frequencies in the S-band spectrum (2310 to 2360MHz). However, satellite-based DAB systems, unlike Eureka 147, cannot deliver cd-clarity audio to stationary and mobile users in open and urban areas, countering the whole purpose of adopting DAB.

The US government's decision has been described by the Consumer Electronics Manufacturers

Association (CEMA) as "disastrous for digital audio radio in the US".

CEMA now hopes to sway the US government towards giving up the L-band frequencies (1452 to 1492MHz), currently reserved for Pentagon use. The L-Band is suited to the improved quality terrestrial delivery of DAB, and CEMA is lobbying to get the Eureka 147 system implemented in the spectrum, even though it believes the license fees demanded for Eureka 147 are too steep for US broadcasters.

Frans Westra, DAB project leader at Philips, countered the claim by saying: "It's not quite clear what is going on, but I have never seen a

technically superior system fail because of high licence fees."

Moreover, certain Eureka 147 DAB receiver makers are not unduly concerned about developments in the US. "Currently we are looking at Europe although we are keeping a close eye on the situation in the States," said Tony Starling, sales director at Kenwood, which is launching the first commercial car-DAB receiver in a couple of week's time.

Eureka 147 has been selected by 20 countries worldwide. Japan has still to choose and is watching developments in the US.

End of 56kbit modem war in sight

Peace talks next month could end the 56kbit/s high speed modem standard war.

Lucent Technologies and Rockwell, who are promoting their joint K56Flex protocol, invited their rival, US Robotics, which is marketing its x2 modem, to the inaugural meeting of the Open 56K

Forum held in New York.

Although US Robotics could not make the conference in time - "Unfortunately, they only asked us to join half-an-hour before the first meeting," said a US Robotics spokesperson - the company is considering taking part in the next one, scheduled for later this month.

It raises the possibility that all three companies contribute to a common standard which would be put before the International Telecommunications Union (ITU) for approval, so users can be confident the modem they buy will be compatible with those used by all Internet service providers.

UMIST researches self drive cars

Cars which drive themselves is the goal of research being carried out at University of Manchester Institute of Science and Technology (UMIST). Follow on from the EC-funded Prometheus project aimed at preventing accidents through corrected steering, UMIST is developing vision systems which enable cars to operate on all road types.

Panos Liatsis, of UMIST's Control

Systems Centre, explained that a system for motorway use, where the road is well defined, is relatively straightforward, but "driving within the city is far more adventurous." According to Liatsis, the intelligent sensing system for obstacle detection currently being developed relies on image analysis and neural network techniques. It consists of two modules: one for obstacle detection, the other for classification.

The first module examines an

image for edges, to determine regions of interest (ROIs). The second module uses higher order neural networks (HONNs) to identify obstacles within the ROIs. They decompose ROIs into coarse fields, which are matched with known vehicle shapes.

The system has been tested with 400 images containing objects with different scaling and positions, and achieved a detection accuracy of 96 per cent.

Marconi archive to stay in UK

Guglielmo Marconi's archive of scientific equipment and documents relating to his years developing the first practical radio transmitters at the beginning of the century is to be given to the nation by GEC-Marconi, the present owner.

Original plans to auction the archive - valued at between £1m and £3m - were scrapped earlier this year in response to criticism, including a letter to *The Times* from Marconi's daughter, that the archive was too important to the history of scientific discovery to be broken up.

GEC-Marconi has agreed to give the archive of over 1000 items, which includes Marconi's first patent for improvements to wireless telegraphy, a letter from Queen Victoria and radio message transmitted from the sinking Titanic, to the Science Museum in London.

Part of the archive will be displayed in a Marconi centre to be set up at the Chelmsford site where Marconi built the world's first radio factory.



The Home of *Hi-Finesse*. Its not what you do, its HOW you do it that counts!

Hart Audio Kits and factory assembled units use the unique combination of circuit designs by the renowned John Linsley Hood, the very best audiophile components, and our own engineering expertise, to give you unbeatable performance and unbelievable value for money. We have always led the field for easy home construction to professional standards, even in the sixties we were using easily assembled printed circuits when Heathkit in America were still using tagboards! Many years of experience and innovation, going back to the early Dinsdale and Bailey classics gives us incomparable design background in the needs of the home constructor. This simply means that building a Hart kit is a real pleasure, resulting in a piece of equipment that not only saves you money but you will be proud to own. Why not buy the reprints and construction manual for the kit you are interested in to see how easy it is to build your own equipment the HART way. The FULL cost can be credited against your subsequent kit purchase.

SHUNT FEEDBACK PICKUP PREAMPLIFIER

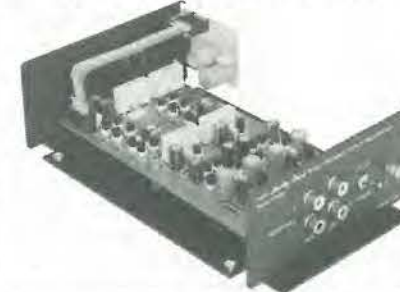

If you want the very best sound out of vinyl discs then you need our high quality preamplifier with Shunt Feedback equalisation. The K1450 also has an advanced front end, specially optimised for low impedance moving coil cartridges as well as moving magnet types. Selected discrete components are used throughout for ultimate sound quality. The combination of John Linsley Hood design, high quality components and an advanced double sided printed circuit board layout make this a product at the leading edge of technology that you will be proud to own. A recent review in "Gramophone" magazine endorsing this view. Bought in kit form our step by step instructions it is very easy and satisfying to assemble, or you can buy a factory assembled version if you wish. This magnificent kit, comes complete with all parts ready to assemble inside the fully finished 228 x 134 x 63mm case. Comes with full, easy to follow, instructions as well as the Hart Guide to PCB Construction, we even throw in enough Hart Audiograde Silver Solder to construct your kit!

K1450 Complete Kit £116.58
K1450SA Audiophile Kit £138.94
A1450SA Factory assembled Audiophile unit £188.94

"CHIARA" HEADPHONE AMPLIFIER



Highest quality, purpose designed, 'single ended' class 'A' headphone amplifier for 'stand alone' use or to supplement those many power amplifiers that do not have a headphone facility. Easy installation with special signal link-through feature, the unit uses our 'Andante' Ultra High Quality power supply. Housed in the neat, black finished, Hart minibox it features the wide frequency response, low-distortion and 'musicality' that one associates with designs from the renowned John Linsley Hood. Volume and balance controls are Alps "Blue Velvet" components. Very easy to build, or available factory assembled, the kit has very detailed instructions, and comes with Hart audiograde silver solder. A valuable personal listening option and an attractive and harmonious addition to any hi-fi system.

K2100 Complete Standard Kit £112.50
K2100SA 'Series Audiophile' Kit with selected audiophile components £115.46
A2100SA 'Series Audiophile', Factory Assembled £115.46
CM2100 Construction Manual £2.50

"Andante" Linear Technology AUDIOPHILE POWER SUPPLIES

The HART "Andante" series power supplies are specially designed for exacting audio use requiring absolute minimum noise, low hum field and total freedom from mechanical noise. Utilising linear technology throughout for smoothness and musicality makes it the perfect partner for the above units, or any equipment requiring fully stabilised ± 15 v supplies. There are two versions, K3550 has 2 ± 15 v supplies and a single 15v for relays etc. K3565 is identical in appearance and has one ± 15 v. Both are in cases to match our "Chiara" Headphone Amplifier and our K1450 "Shunt Feedback" Pickup preamp.

ALPS "Blue Velvet" PRECISION AUDIO CONTROLS.



Now you can throw out those noisy ill-matched carbon pots and replace with the famous Hart exclusive ALPS "Blue Velvet" range components only used selectively in the very top flight of World class amplifiers. The improvement in track accuracy and matching really is incredible giving better tonal balance between channels and rock solid image stability. Motorised versions have 5v DC motor.

MANUAL POTENTIOMETERS
2-Gang 100K Lin. £15.67
2-Gang 10K, 50K or 100K Log. £16.40
2-Gang 10K Special Balance, zero crosstalk and zero centre loss. £17.48

MOTORISED POTENTIOMETERS
2-Gang 20K Log Volume Control £26.20
2-Gang 10K RD Special Balance, zero crosstalk and less than 10% loss in centre position £26.98

TOROIDAL MAINS & OUTPUT TRANSFORMERS
for EL34, 32W VALVE AMPLIFIER

Special set of toroidal transformers, 2 output & 1 mains for the "Hot Audio Power" valve amplifier design described in the Oct. 1995 issue of "Wireless World". Total Wt 4.8Kg. Special price for the set. £99, Post £8
RJM1. Photocopies of the Article by Jeff Macaulay. £2

PRECISION Triple Purpose TEST CASSETTE TC1D.

Are you sure your tape recorder is set up to give its best? Our latest triple purpose test cassette checks the three most important tape parameters without test equipment. Ideal when fitting new heads. A professional quality, digitally mastered test tape at a price anyone can afford.
Test Cassette TC1D. Our price only £9.99

SPEAKER DESIGN SOFTWARE

VISATON "Speaker Pro 6" is a complete speaker design program for use on IBM machines. Covers cabinet and crossover design and contains a full expandable database of drive units. Earning a "most recommendable" accolade it tests this program is ideal for the professional speaker builder or serious audiophile.

0303 Speaker Pro 6, 3.5" Disk £45.51
0309 Demo Version with Database £9.28

SPEAKER DAMPING MATERIALS

Polyester Wool and Pure Lambs Wool both have optimal damping properties and are pleasant to handle. Standard 125g bag is sufficient for 20 litres enclosure volume.
5070 Polyester Wool, 125g £3.20
5069 Pure Lambs Wool, 125g £6.73

ROARING SUBWOOFER.
A full revised kit will be available soon for this excellent and imaginative design from Russel Bredon (VW Feb 97). The latest design will use the 30mm maximum cone displacement of the 10" VISATON GF250 Driver to give even better performance at slightly reduced cost. Featuring a rubber suspended fiberglass cone, extended pole plate, vented magnet, Kapton carrier and dual 4ohm voice coils the GF250 is unbelievably good value at only £111.45 each.

SPECIAL OFFER! SOLENOID CONTROLLED FRONT LOAD CASSETTE DECK SFL800
High quality (0.08%W&F) cassette mechanism with capability of using standard or downstream monitor R/P head. Offers all standard facilities under remote, logic or software control. The control requirements are so simple that for many applications not needing all functions manual switches will suffice. Power requirements are also simple with 12v solenoids and 12v speed controlled Motor, total power requirement being under 300mA. Logic control and wiring circuits are included free with each deck.
SFL800 Deck with Standard stereo head £29.50
SFL800D Fitted with High Quality Downstream monitor head. £44.90
(The Head alone is normally over £60!)

- HART TECHNICAL BOOKSHELF**
Try us for:- Bigger Range of Books, Better Prices, NO "28 Day Wait"
- "AUDIO ELECTRONICS" John Linsley Hood £18.99*
 - "THE ART OF LINEAR ELECTRONICS" John Linsley Hood, 1994 £16.95*
 - "THE ART OF ELECTRONICS" Horowitz & Hill £35.00*
 - "DIGITAL AUDIO AND COMPACT DISC TECHNOLOGY" 3rd.Edn. 0-240 51397 5 £19.95*
 - "INTRODUCING DIGITAL AUDIO CD, DAT AND SAMPLING" ISBN 1870775 22 8 £7.95
 - "ACTIVE FILTER COOKBOOK" Don Lancaster £19.95
 - "HOW TO USE OSCILLOSCOPES & OTHER TEST EQUIPMENT" R.A.Penfold, BP267 £3.50
 - "THE HART PRINTED CIRCUIT BOARD CONSTRUCTION GUIDE" £2.50
 - "A SIMPLE CLASS A AMPLIFIER" J.L.Linsley Hood M.I.E.E. 1969. RLH12 £2.75
 - "CLASS-A POWER" Single Ended 15W Amp. J.L.Linsley Hood M.I.E.E. 1996. RLH13 £2.50

- LOUDSPEAKERS; THE WHY AND HOW OF GOOD REPRODUCTION.** G.Briggs. 1949. £8.95
- "THE LOUDSPEAKER DESIGN COOKBOOK" Vance Dickason. (5th Edn.) £23.95*
- ELECTROSTATIC LOUDSPEAKER DESIGN AND CONSTRUCTION** Ronald Wagner BKT6 £15.95
- "THE ELECTROSTATIC LOUDSPEAKER DESIGN COOKBOOK" Roger P.Sanders. 1995 £24.95
- "BULLOCK ON BOXES" Bullock & White £10.95
- "AN INTRODUCTION TO LOUDSPEAKERS & ENCLOSURE DESIGN" V. Capel, BP256 £3.95
- "LOUDSPEAKERS FOR MUSICIANS" BP297 £3.95
- "THEORY & DESIGN OF LOUDSPEAKER ENCLOSURES" J.E.Benson £21.95
- "QUICK & EASY TRANSMISSION LINE SPEAKER DESIGN" Larry D.Sharp £8.95
- "THE COUPLED CAVITY HANDBOOK" David Purton £4.90
- "VISATON, HOME HI FI CATALOGUE." Full Specifications and Thiele Small Data on all Drive Units £4.50
- "VISATON, CAR HI FI CATALOGUE." In car guide £3.50
- "VISATON, CABINET PROPOSALS" Book 1, In GERMAN £6.50
- "VISATON, CABINET PROPOSALS" Book 2, In GERMAN £6.50
- "SPEAKER PRO 6," VISATON Cabinet Design Software £45.51
- "SPEAKER PRO 6," Demo Version with drive unit database £9.28

"VALVE AMPLIFIERS" Morgan Jones. 1995/6 £24.50
THE VTL BOOK David Manley 1994. BKV1 £17.95
MULLARD TUBE CIRCUITS FOR AUDIO AMPLIFIERS BKAA27 £11.95
"THE WILLIAMSON AMPLIFIER." 0-9624-1918-4 £6.95
AN APPROACH TO AUDIO FREQUENCY AMPLIFIER DESIGN. GEC 1957 £17.95
AUDIO ANTHOLOGIES, articles from Audio Engineering. Six volumes covering the days when audio was young and valves were king! BKAA3/1 to 6. All £12.95 each
"THE RADIOTRON DESIGNERS HANDBOOK" (CD) £49.00
"PRINCIPLES OF ELECTRON TUBES" H.D.Reich P.H.D. £25.95
"POWER AMP PROJECTS" Anthology, 1970-1989. £15.50
"WORLD TUBE DIRECTORY" 1996-7 Sourcebook of valve related products £5.95
Fuller descriptions of the contents of all our books is given in our full catalogue, price £4.50

Postage on all books, unless starred, is only £2 per book, maximum £4.50 for any number, any size! Starred items are heavy books costing £3.50 to send.
Don't forget No waiting at HART! All listed books are normally in stock! Just ring with your Credit Card Number for instant despatch!

POSTAGE on UK Orders up to £20 is £2. Over £20 is £4.50. OVERSEAS Please Enquire. Fuller Details of ALL kits are given in our List, FREE on request.

Send for Your FREE copy of our LISTS 24 Hr. ORDERLINE 01691 652894 Fax. 01691 662864 All Prices include UK/EC VAT.

HART
HART ELECTRONIC KITS LTD.
1 Penylan Mill, OSWESTRY, Shropes SY10 9AF, UK

Intel to lose ground

Intel is the undisputed king of the x86 microprocessor market. But it will lose a big chunk of its market over the next three years, predicts US market research firm Dataquest, which is impressed with the performance of Advanced Micro Devices' new K6 microprocessor.

Advanced Micro Devices (AMD), Cyrix and others, could snag 25 percent of the market by the year 2000, reducing Intel's share from 95 percent to 75 percent. The x86 microprocessor market was worth about \$15.4bn in 1996.

A key beneficiary of Intel's lower market share will be AMD which has managed to match the performance of Intel's microprocessors with its K6 microprocessor.

"Unlike prior incursions, when AMD arrived with too little fab capacity or too late with competitive performance, this time, bolstered by the technology boost it received via its NexGen acquisition, AMD's gun may shoot real bullets," said Nathan Brookwood senior analyst at Dataquest.

Hand-held records MPEG

In 1995, Hitachi developed a prototype camera that recorded digital video on a 400MB multi-layered flash memory. Now the company has demonstrated a camera that can record JPEG compressed still images and MPEG-1 compressed full motion video on a slot-in PCMCIA hard disk. And it's small enough to be held in the hand. The breakthrough has come through Hitachi's development of a single chip integrating the 300,000 components necessary to handle all camera functions, including real-time MPEG-1 and high speed JPEG encoding/decoding and playback. This CODEC LSI chip uses a 3-layer 0.5 micrometre c-mos process, and has a power consumption of 500mW (the camera consumes 6.5W in total). Image resolution is said to be greater than 352x240 dots. The 260MB disk can store up to 2880 JPEG images – or 1000 with 10 seconds of MPEG audio each – 20 minutes of MPEG-1 video and audio, or four hours of audio alone.



NEWS IN BRIEF

BT has received a veiled warning from industry regulator Oftel over its plans to become a global telecommunications group. Oftel is to investigate whether BT's expansionist plans, which includes the proposed merger with US operator MCI, will have a detrimental impact on the telephone operator's services domestically.

After a consultation period Oftel will decide whether any safeguards should be added to BT's license. "It is possible that BT's moves towards globalisation may have an impact on the company's ability and willingness to meet its UK license obligations," said Oftel director general Don Cruickshank.

DVD-ram, the rewritable version of digital versatile discs, or DVDs, has moved a step closer to its commercialisation. Last week ten major consumer electronics firms agreed on a single DVD ram format. Its specification will be published later in April.

Toshiba demonstrated its version of DVD ram hardware in Tokyo last month.

Other equipment makers are expected to produce DVD ram systems sometime before the spring of 1998.

USA Global Link has introduced what it says is the first worldwide Internet telephony system.

The Global Internet service will be offered in 35 countries with rates varying between 25 cents and 50 cents per minute. The company claims that voice quality will be comparable with satellite-routed phone calls which often have a voice delay, but will be better than using Internet-connected PCs to call other PC users.

Global Link is not the first company to offer such services but it is the first to plan a worldwide one. The company is a leading 'call back' firm, offering overseas clients cheap phone rates by offering access to a US dial tone and cheap US phone rates.

The company plans to install gateways in various countries that will connect local phone users to the Internet. However, there are concerns that such services will further congest the already overburdened Internet.

Philips back in the top ten

Philips has returned to the top ten of the world's semiconductor manufacturers, according to industry analyst Dataquest (see table below).

Dataquest's final 1996 worldwide market rankings shows that Philips, after increasing revenues by 8.2 per cent on 1995, is at number nine, just ahead of SGS-Thomson Microelectronics. Mitsubishi dropped out of the top 10 to number 11 with revenues of \$4.1bn.

Provisional figures, released in January have been largely confirmed with Philips and Mitsubishi being the only companies to swap positions.

World wide semiconductor ranking for 1996

1	Intel	17.781
2	NEC	10.428
3	Motorola	8.076
4	Hitachi	8.071
5	Toshiba	8.065
6	TI	7.064
7	Samsung	6.464
8	Fujitsu	4.427
9	Philips	4.219
10	SGS-Thomson	4.112

M/A COM, the US microwave and rf specialist has produced a range of very low cost 14GHz Schottky diodes in plastic packaging. Charles Howell, a company spokesman, said: "Consumer applications like DBS and VSAT can't afford \$5 for a ceramic part. Plastic packaged diodes cost 25 to 30¢ and we got the capacitance on ours down to allow them to work at 14GHz." Schottky diodes are used as mixers for frequency converters in receivers. Howell said: "The highest frequency diodes, in hand assembled and tuned beam-lead packages, will work at 100GHz."

ICER, the Industry Council for Electronic Equipment Recycling, has launched its design guidelines for the recycling of electrical and electronic equipment. "The guidelines include information on the principles of designing for recycling and cover developing an appropriate design strategy," said Claire Snow, the director of ICER. The launch is to be followed by an industry-wide consultation process, promoted by ICER, beginning in April.

● The 30 page ICER Guidelines: Design for Recycling Electronic and Electrical Equipment document is available at £20 from ICER. Tel: 0171 729 9121.

Mix it up

with **Electronics Workbench[®] EDA**

The analog, digital and mixed-mode circuit simulator that really moves!

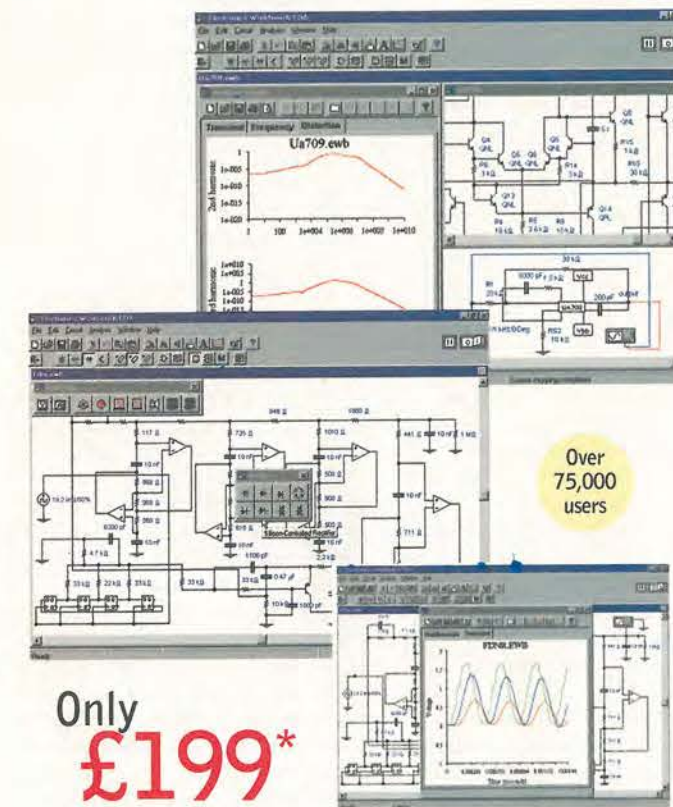

Over 75,000 users

Only **£199***

Turn on the power to your designs...
CALL + 44 (0) 1203 233216 today!

NEW! Electronics Workbench Version 5 with analog, digital and mixed A/D SPICE simulation, a full suite of analyses and over 4,000 devices. Still the standard for power and ease of use. Now ten times faster. Still the same low price.

Join over 75,000 customers and find out why more engineers and hobbyists buy Electronics Workbench than any other SPICE simulator. You'll be working productively in 20 minutes, and creating better designs faster. We guarantee it!

High-End Features

True Mixed Analog/Digital	Yes
Fully Interactive Simulation	Yes
Analog Engine	Spice 3F5, 32-bit
Digital Engine	Native, 32-bit
Temperature Control	Yes
Pro Schematic Editor	Yes
Hierarchical Circuits	Yes
Virtual Instruments	Yes
On-Screen Graphs	Yes
Analog Components	Over 100
Digital Components	Over 200
Device Models	Over 4,000
Money-Back Guarantee	30-day
Technical Support	Free

Powerful Analyses

DC Operating Point	Yes
AC Frequency	Yes
Transient	Yes
Fourier	Yes
Noise	Yes
Distortion	Yes



No-risk 30-day money-back for first time buyers!

Runs on Windows 95/NT/3.1

*Special upgrade prices are available. All prices are exclusive of VAT and £7.99 p+p.

Robinson Marshall (Europe) Plc.
Leofric Business Park, Progress Close, Coventry CV3 2TF

Phone: +44 (0) 1203 233216 Fax: +44 (0) 1203 233210 E-mail: sales@rme.co.uk www.rme.co.uk

Shipping Charges UK £7.99. All prices are plus VAT. Electronics Workbench is a trademark of Interactive Image Technologies Ltd, Toronto, Canada. All other trademarks are the property of their respective owners



Australia • Belgium • Brazil • Canada • Chile • Colombia • Cyprus • Czech Republic • Denmark • Finland • France • Germany • Greece • Hong Kong • Hungary • India • Indonesia • Israel • Italy • Japan • Malaysia • Mexico • Netherlands • New Zealand • Norway • Philippines • Portugal • Romania • Singapore • Slovenia • South Africa • South Korea • Spain • Sweden • Switzerland • Taiwan • Thailand • Turkey • United Arab Emirates • United Kingdom

Trademarks are the property of their respective holders.

RESEARCH NOTES

Jonathan Campbell

Computer can respond to thought

Research at Imperial College could open up the world for severely disabled people by allowing them to communicate through computer – simply by thinking.

Will Penny and colleagues, researching into biosignals as part of the Brian Computer Interface project, are attempting to use information from the motor cortex region of the brain, recorded using electrodes attached to the scalp, to interface directly with a computer.

The basis for the work is that movements of limbs, for example, are preceded by desynchronisations and synchronisations within the electroencephalogram (EEG). But these event-related

desynchronisations and synchronisations (ERD and ERS), appear to be present when volition to move a limb occurs, even when actual movement of the limb does not in fact take place.

Clearly, the accurate real-time determination and classification of the ERD/S offers many exciting possibilities for the control of peripheral devices via computer analysis.

This project aims to research this protocol. The primary application is expected to be computer interfacing and control by severely disabled people. But the methodology is general and has numerous other application areas.

Key areas of technical research to be solved include better preprocessing techniques for the spontaneous (non-averaged) EEG and development of suitable pattern recognition algorithms. This will also include investigation of dynamic 'neural' network architectures.

Research effort will also be directed at the issues of multi-channel sensor fusion and the development and use of methods for assessing 'confidence' measures (or error estimates) for the output of neural classifiers.

Will Penny, Department of Electrical Engineering, Imperial College, London SW7 2BT, UK. Email: w.penny@ic.ac.uk.

Yu-Hwa Lo, Cornell University associate professor of electrical engineering, right, and Felix Ejeckam, doctoral candidate, examine transmission electron microscope photographs that demonstrate the success of a technique they developed for a universal substrate for compound semiconductors. Photo by Charles Harrington, Cornell University.

Revolutionary twist for silicon manufacturing

Scientists at Cornell university have announced creation of a "universal substrate" for semiconductors, promising to eliminate many of the obstacles in conventional semiconductor manufacturing. The technique allows

pure, single crystal growth of any film on a semiconductor substrate.

Results are still in their preliminary stages, but if the idea truly works – and the researchers are confident it will – the technique could revolutionise the microelectronics industry.

The potential is "unimaginable", according to Yu-Hwa Lo, Cornell associate professor of electrical engineering who is leading the work opening the door for manufacturing whole new classes of devices in optoelectronics and microelectronics, for such items as new lasers, detectors, sensors, imaging systems, signal processing and computer chips, compact discs, data storage and dozens of other examples.

Conventionally, a major obstacle to the manufacture of semiconductors is that the single-crystal semiconductor thin films must be deposited on a crystal of the same structure. For example, a light-emitting gallium arsenide thin film must be deposited on a gallium arsenide bulk substrate, or else defects will result and the semiconductor cannot be used.

Each single crystal is characterised by its lattice structure and lattice constant. When a crystal layer is grown on a bulk crystal substrate, even a mismatch of 1% in lattice constants causes problems. But the

Cornell technique, for which Cornell has applied for a patent, shows that a mismatch of 15% can be overcome – a feat previously unachievable.

The Cornell team solved that problem by what might be called a simple twist. By rotating a thin film slightly and bonding it to a substrate, the surface of this new substrate becomes flexible, or compliant, and a crystal of any material can grow on its surface. The researchers call it a twist boundary, in which the crystal materials are bonded by angular misalignment; and the result is a new compliant substrate.

The Cornell team has demonstrated the technique with thick, pure crystal layers of indium gallium phosphide, gallium antimonide and indium antimonide, with mismatches as high as 15%. Crystals of these compounds have successfully been grown on a gallium arsenide wafer that had a flexible layer thin film. With traditional methods, it would not have been possible.

The Cornell team, in collaboration with researchers from the Wright Patterson Laboratory and the Sandia Laboratory, has demonstrated that the defect density in an indium antimonide layer has been reduced by at least 100,000 times with the new method, compared to the conventional method. This means

NOW, THE BATTLE IS REALLY OVER



After 10 years and with more than 20,000 users, ULTimate Technology now introduces the ULTiboard Wizard. This system is highly praised for its very powerful placement and routing algorithms by both the less experienced users and by the experts. The technology applied in the ULTiboard Wizard used to be available only as options on the more powerful and expensive Workstations. The PCB design depicted below illustrates the capability of the Wizard, its 4-layer version was employed in the ULTiboard Professional Design Contest at the Electronics'95 Exhibition. The same design was now executed in a 2-layer version with the ULTiboard Wizard in less than 2 hours.

ULTIBOARD WIZARD



The schematic is ready, the board outline established and all components are imported. The components with a fixed location are placed interactively. (10 min.)

AutoPlace rapidly and conveniently places the remaining components with algorithms that approach the interactive method of expert designers. On-line changes are possible. (5 min.)

Power and Ground are routed semi-automatically (under the management of the designer). The (EMC) critical connections are also laid interactively. (15 min.)

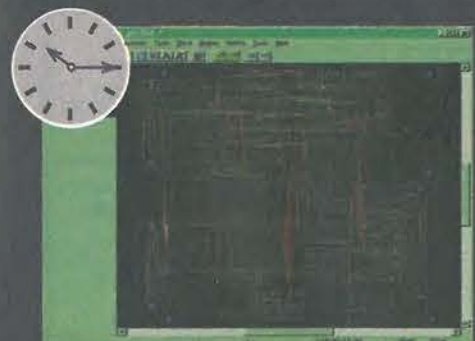

Now the SPECTRA Autorouter is employed to finish the routing of the design at high speed and with high-grade quality. All design rules

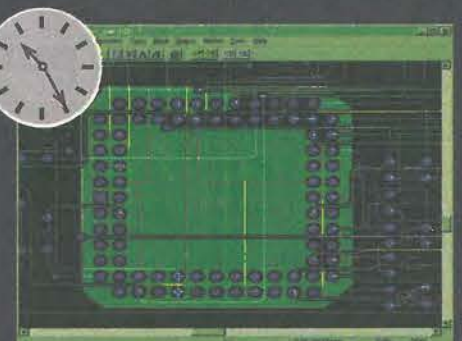

All adjustments are done quickly and efficiently with the interactive autorouter. All the corners of the traces are chamfered and polygons are placed. (10 min.)

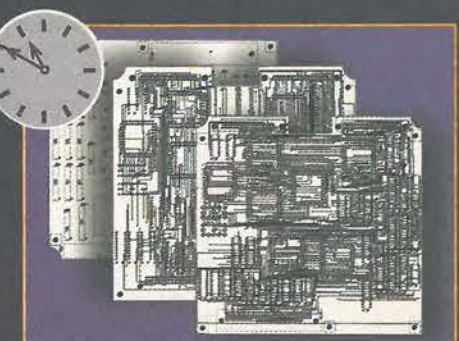

Following the connectivity- and design rule checks, the output on matrix or laser printers, pen or photo plotters can be run. Back-Annotation automatically updates the schematic. (25 min.)

ULTimate Technology now makes the best PCB Design tools available at very competitive prices from UK £ 2,675,- (Excl. VAT, 1400 pins version with 4 signal layers). We imagine you will want to see for yourself whether you too can achieve such fantastic results with the ULTiboard Wizard. Please come to our stand J135 at ICAT 97 at NEC (Birmingham) and convince yourself. A demo-CD is available.

CIRCLE NO. 138 ON REPLY CARD

ULTIMATE
TECHNOLOGY

Email: sales@ultiboard.com
Internet: http://www.ultiboard.com

UK/Ireland Sales-Office:
1 Viney Woodside • Lydney
Gloucestershire • GL15 4LU • U.K.
tel.: (+44) 1594 - 516647
fax: (+44) 1594 - 516659

Corporate Headquarters:
Energistraat 36 • 1411 AT Naarden
The Netherlands
tel.: (+31) 35 - 6944444
fax: (+31) 35 - 6943345

that indium antimonide crystals can be grown on gallium arsenide, to form the basis for infrared detection and a Hall sensor – a sensor that has been used in airplanes and soon will be used in cars.

If this can be done for another compound semiconductor, gallium nitride, which has a lattice mismatch of about 20%, then high-quality blue and ultraviolet lasers as well as high-

temperature, high-power electronic circuits can be fabricated.

Blue lasers, rather than red, will be used in the next generation of compact discs, for example, because the shorter wavelength stores more data. High-powered electronic circuits that can also withstand high temperatures are used in automobile, aerospace, communication and power industries.

The Cornell team expects it can be

achieved with this technique, and is currently in the process of trying it. The researchers also believe that the crystals can be grown on silicon wafers, opening the door for computers that, for example, could have different types of semiconductors operating at the same time on the same motherboard.

Contact: Yu-Hwa Lo, Electrical Engineering, Cornell University,

Sun power put into practice . . .

Data being collected from a 0.75-acre 342kW photovoltaic system at Georgia Tech is providing a valuable insight into how commercial solar electricity generation might work in real world applications.

shutdowns, but will help take the guesswork out of solar energy production.

In the future, researchers plan to study "islanding," where the main power source shuts down but the photovoltaic system continues to function. This creates a safety hazard for workers doing maintenance or repairs, especially if they're not aware of the secondary power source.

The Georgia Tech system is made up of 2856 photovoltaic modules, each with 72 multicrystalline silicon solar cells connected in series. A power conditioning system, or inverter, converts the array's dc power to utility-compatible ac power, which then feeds into the Aquatic Center's main power system. The inverter also controls and monitors the overall photovoltaic system.

A data acquisition system samples all vital signs every 10s, then averages and stores them every 10min. Incoming data includes meteorological parameters such as ambient air temperature, wind velocity and array temperature, and

performance parameters such as ac power, dc voltage and dc current.

Although the photovoltaic system is operating as expected, researchers continue to seek ways to improve solar energy production. At 10-15% efficiency, photovoltaic systems are below traditional ones like coal, natural gas or nuclear power, which have efficiency ratings that fall somewhere between 30-60%. But their fuel source – the sun – is free and unlimited, and its operation is silent and non-polluting.

"There's money to be made in solar technology for those far-sighted enough to make the investment," said Christine Ervin, assistant secretary of the DOE's Office of Energy Efficiency and Renewable Energy. "The work we're supporting at Georgia Tech is at the cutting edge of this technology. What we learn from projects like the Aquatic Center increases the confidence of those potential investors in photovoltaic products and sets the foundation for our industry's growth and profitability."

. . . And put into space

Aeronautical engineers in Southern California are developing an aircraft – called Centurion – that they believe will push solar-powered aircraft concepts to new heights, and provide a vehicle for scientific experiments.

Engineers for AeroVironment are designing the aircraft to fly at over 30,000m altitude as part of Nasa's Environmental Research Aircraft and Sensor Technology (Erast) program. Like its predecessor, the AeroVironment-developed Pathfinder, the Centurion will be an ultralight flying wing with multiple electric motors along its wingspan, powered by solar cells spread across the wing's upper surface. But

Centurion's wingspan, will be more than twice that of Pathfinder.

According to Dryden reports, recent flight tests of a quarter-scale battery-powered model of the craft at El Mirage Dry Lake in Southern California's high desert have answered questions about the Centurion's aerodynamics and stability. Next step is to scale up the aircraft, designing new airfoils that are more efficient for high altitudes and optimising the systems.

The final solar-powered Centurion will be designed to reach the ultrahigh 30,000m altitude for a relatively short duration – about 2h – while carrying a small 90kg payload of scientific sensors. The full-scale



Doctoral student Mike Ropp with the 342-kilowatt photovoltaic system on top of the Georgia Tech Aquatic Center. Photograph Stanley Leary, Georgia Tech Communications Division.

So far, the system, installed at Georgia Tech's Aquatic Center, has operated close to its expected efficiency, although actual energy production has been lower than predicted. For the seven-month period from July 1996 through to January 1997, it produced 162.2MWh of electricity, against a predicted 409MWh, which is enough to power about 35 average homes.

Factors that affected energy output, included fuses blown when lightning struck the Center roof in July and a water main break that flooded the electrical control room and forced a 10-day shutdown in October. Also, sunlight levels were lower than expected and extremely high temperatures in August decreased the efficiency of the system, which operates better in cooler temperatures.

Continuing experiments to compare performance-model equations to the real operating data brought further

New Special Offers	
New mini waterproof TV camera 40x40x15mm requires 10 to 20 volts at 120mA with composite video output (to feed into a video or a TV with a SCART plug) it has a high resolution of 450 TV lines Vertical and 380 TV lines horizontal, electronic auto iris for nearly dark (1 LUX) to bright sunlight operation and a pinhole lens with a 92 degree field of view, it focuses down to a few CM. It is fitted with a 3 wire lead (12v in gnd and video out)..... £93.57 + VAT = £109.95 or 10+ £89.52 + VAT = £104.95	Used 8748 Microcontroller..... £3.50
High quality stepping motor kits (all including stepping motors) Computer independent control of 2 stepping motors by PC (Via the parallel port) with 2 motors and software..... Kit £67.00 Ready built £99.00	SL552 UHF Limiting amplifier LC 16 surface mounting package with data sheet..... £1.95
Software support and 4 digital inputs kit..... £27.00	DC-DC converter Reliability model V12PS 12v in 5v 200ma out 300v input to output Isolation with data..... £4.95 each or pack of 10 £39.50
Power interface 4A kit..... £56.00	Hour counter used 7 digit 240v AC 50Hz..... £1.45
Power interface 8A kit..... £46.00	QWERTY keyboard 58 key good quality switches new..... £6.00
Stepper kit 4 (manual control) includes 200 step stepping motor and control circuit..... £29.50	Airpax A82903-C large stepping motor 14v 7.5 step 270mm 68mm dia body 6.3mm shaft..... £8.95 or £290.00 for a box of 30
Hand held transistor analyser it tells you which lead is the base, the collector and emitter and if it is NPN or PNP of faulty..... £35.45	Polyester capacitors box type 22.5mm lead pitch 0.9uf 250vdc..... 18p each
Standard charger charges 4 AA cells in 5 hours or 4 C or Ds in 12-14 hours + 1xPP3 (1, 2, 3 or 4 cells may be charged at a time)..... £5.95	14... 100+ 9p... 1000+..... 20p each
High power charger as above but charges the Cs and Ds in 5 hours. AAs, Cs and Ds must be charged in 2s or 4s..... £10.95	15p... 100+ 10p... 1000+..... 15p each
Nickel Metal Hydride AA cells high capacity with no memory. If charged at 100ma and discharged at 250ms or less 1100MAH capacity (lower capacity for high discharge rates)..... £3.75	1uf 50v bipolar electrolytic axial leads..... 7.5p 1000+ 0.22uf 250v polyester axial leads..... 15p each
Special offers, please check for availability.	Polypropylene 1uf 400vdc (Wima MKP19)..... 7.5p 100+ 27.5mm pitch 32x29x17mm case..... 7.5p each
Sick of 4 42x16mm Nicad batteries 171x16mm dia with red & black leads 4.8v..... £5.95	Philips 123 series solid aluminium axial leads - 35uf 10v & 2uf 40v..... 40p each
5 button cell 6V 280MAH battery with wires (Varta 5x250DK)..... £2.45	Philips 108 series long life 22uf 63v axial..... 25p each
Shaded pole motor 240Vac 5mm x 20mm shaft 80x60x55mm excluding the shaft £4.95 each	Multilayer AVX ceramic capacitors all 5mm pitch 100v 100pf, 150pf, 220pf, 10,000pf (10n)..... 10p each 5p... 100+ 3.5p... 1000+ 500pf compression trimmer..... 60p
115v AC 80v DC motor 4x22mm shaft 50mm dia x 60 long body (excluding the shaft) it has a replaceable thermal fuse and brushes..... £4.95 each (£3.95 100+)	40 uf 370vac motor start capacitor (dielectric type containing no PCBs)..... £5.95 or £49.50 for 10
7 segment common anode led display 12mm..... £0.45	Solid carbon resistors very low inductance ideal for RF circuits – 270hm 2W, 680hm 2W..... 25p each
LM357k TO3 case variable regulator..... £1.44 100+ GaAs FET low leakage current 58873..... £12.95 each £9.95 10+ £7.95 100+ £0.45	We have a range of 0.25w, 0.5w, 1w and 2w solid carbon resistors, please send SAE for list.
BS250 P channel mosfet..... £0.45	P.C. 400W PSU (Intel part 201035-001) with standard motherboard and 5 disk drive connectors, fan and mains inlet/outlet connectors on back and switch on the side (top for tower case) dims 212x149x149mm excluding switch..... £26.00 each £138.00 for 6
BC559 transistor..... £3.95 per 100	MX180 Digital multimeter 17 ranges 1000vdc 750vac 2Mohm 200mA transistor Hfe 9v and 1.5v battery test..... £9.95
BC547 A transistor..... £0.20 for £1.00	AMD 47256-3 Eeproms..... £2.00 each £1.25 100+ DIP switch 3PCD 12 pin (ERG SDC-3-025)..... 60p each
74LS05 hex inverter..... £10.00 per 100	Disk drive boxes for 5.25 disk drive with room for a power supply, light grey plastic, 67x268x247mm..... £49.50 for 10
	Hand held ultrasonic remote control..... £3.95 CV2486 gas relay, 30x10mm dia with 5 wire terminals, will also work as a neon light..... 20p each
	Verbatim R300NH Streamer tape commonly used on nc machines and printing presses etc. it looks like a normal cassette with a slot cut out of the top..... £4.95 ea.
	HSV-240S-E5 5-24v 50mA regulator ic 18-264vac input 8 pin DIL package..... £5.49 each (100+ £2.25)
	LM 555 timer ic 16p..... 8 pin DIL socket 6p

All products advertised are new and unused unless otherwise stated. Wide range of CMOS TTL 74HC 74F Linear Transistors kits. Rechargeable batteries, capacitors, tools etc always in stock. Please add £1.95 towards p&p. VAT included in all prices.

JPG Electronics, 276-278 Chatsworth Road, Chesterfield S40 2BH
 Access/Visa Orders (01246) 211202 Fax: 550959
 callers welcome 9.30am to 5.30pm Monday to Saturday

CIRCLE NO. 112 ON REPLY CARD

ADVANCED ACTIVE AERIAL

The aerial consists of an outdoor head unit with a control and power unit and offers exceptional intermodulation performance: SOIP +90dBm, TOIP +55dBm. For the first time this permits full use of an active system around the lf and mf broadcast bands where products found are only those radiated from transmitter sites.

- General purpose professional reception 4kHz-30MHz.
- -10dB gain, field strength in volts/metre to 50 Ohms.
- Preselector and attenuators allow full dynamic range to be realised on practical receivers and spectrum analysers.
- Noise - 150dBm in 1Hz. Clipping 16 volts/metre. Also 50 volts/metre version.

- ★ Broadcast Monitor Receiver 150kHz-30MHz.
- ★ Stabilizer and Frequency Shifters for Howl Reduction
- ★ Stereo Variable Emphasis Limiter 3
- ★ 10-Outlet Distribution Amplifier 4
- ★ PPM10 In-vision PPM and chart recorder
- ★ Twin Twin PPM Rack and Box Units.
- ★ PPM5 hybrid, PPM9 microprocessor and PPM8 IEC/DIN -50/+6dB drives and meter movements
- ★ Broadcast Stereo Coders
- ★

SURREY ELECTRONICS LTD
 The Forge, Lucks Green, Cranleigh, GU6 7BG.
 Telephone: 01483 275997. Fax: 276477.

CIRCLE NO. 113 ON REPLY CARD

Q. Why Simulate?

A. Because It Really Works...

...when you have the right software tools. With Intusoft's ICAP/4, The Virtual Circuit Design Lab, you can simulate the toughest System, IC, and Board-level designs.

You said you would do more simulation if the tools were easier to use. Well here you go!

→ Ease of Use for The Beginner, Power For The Professional
 With ICAP/4Windows you can sweep ANY circuit variable from the schematic and instantly view the results. Seamless schematic-simulator integration makes it easy to see the effects of design changes.



→ Unmatched SPICE Power
 Interactive Native Mixed Mode SPICE 3F and XSPICE based simulator with unlimited circuit size
 Simulate all types of designs: Power, ASIC, RF, Analog, Digital, Electro-Mechanical
 Advanced Features: AHDL Modelling, Latest BSIM3 MOS model, Simulation Alarms, Scripting Language
 State-of-the-Art Convergence Algorithms
 Powerful Behavioural Modelling Enhancements
 New.. Interface Your Simulation with Test Hardware

→ Bigger SPICE libraries than ANY other vendor
 8000+ models with more model types than any other vendor! Special RF and Power Libraries!

→ Integration With OrCAD® Capture™ or Protel® Schematic™
 We are the first to bring you real integration with other schematic packages using OLE2 techniques. You can run IsSpice directly from other schematics and cross-probe the results. All simulation functions are available from dialogues and little or no typing is required.

→ Software That Meets Your Needs
 New Network Version (No Protection Key Required)
 Unmatched Free Support
 No maintenance fees
 Windows, 95, NT, DOS, Macintosh, Power Mac

→ Upgrade path:
 ICAP/4Lite → ICAP/4Lite Xtra → ICAP/4Windows
 three complete design and simulation systems, with increasing functionality.

Simply The Best SPICE At An Unbeatable Price!

New!

Magnetics Designer for transformer & inductor design

Even Newer!

Test Designer for fault analysis & design testability

(demo available)

Download Your FREE SPICE Simulation Kit, App Notes, and FREE Model Libraries!

Web Site: <http://www.softsim.com>
 email: info@softsim.com

Technology Sources, 2 Signet Court, Swanns Road, CAMBRIDGE CB5 8LA trading as:
 Phone: 01223-516469
 Fax: 01223-729916



Millimetre-sized machines could provide jet thrust

Could an array of hundreds of tiny jet turbines, each a fraction of a cm wide, one day replace a single jet engine to power an aircraft? That is what researchers at Stanford University's Rapid Prototyping Laboratory hope, and is among the blue-sky possibilities suggested by a new approach to mechanical design called massively parallel mechanical systems.

Although replacing a jet engine is well beyond the current state of the art, the scientists propose demonstrating the value of this approach by building several simpler but still useful devices.

One such device is a system to keep aircraft wings from stalling, a condition that causes the wing to lose the upward force that keeps it in the air: another is a tactile interface for virtual reality and tele-operation systems.

The aircraft device would work by covering critical parts of a wing with thousands of tiny holes each about 1mm in diameter and separated by

5mm. In front of each hole would be a small pressure sensor. When a sensor detects the conditions that precede a stall, it instructs a tiny valve to open, allowing a jet of pressurised air to blow out through the hole behind it. If properly triggered, such jets could prevent a stall from developing.

The tactile interface for virtual reality systems would be next step on from force feed-back mechanisms that are currently used and give tele-operators a better feel for what they are manipulating. The new device would be something like a flat pin cushion, consisting of a dense array of millimetre-square pins attached to actuators that would position and push them up and down with a controllable amount of force. The millimetre spacing between individual pins would make the interface feel almost like a solid surface when all the pins are positioned at the same level. Under computer control, however, the surface could be programmed to imitate the shape and

Centurion will span between 70 and 80m.

The Centurion is one of several unpiloted aircraft being developed by an alliance between Nasa and several small aeronautical development companies and universities under the Erast program. The goal of the program is to develop aeronautical technologies that will lead to development of a new family of high-flying remotely piloted aircraft for scientific missions.

Test results of the quarter scale model have made scientists optimistic about developing a pilotless solar aircraft that will fly at 30,000m.

hardness of different surfaces.

The difficulty with such engineering is that it falls between normal manufacturing methods that can create objects a cm or larger, and micro-mechanical devices that measure a few microns made using semiconductor manufacturing techniques.

The Stanford team is currently developing methods to make large numbers of mesoscale-sized mechanical devices, by combining two different types of techniques – miniaturising traditional manufacturing methods while scaling up techniques used in the semiconductor industry.

So far the researchers have fabricated an array of nine nickel wheels, each one 0.3mm thick and 5mm in diameter, mounted on nickel axles to demonstrate they can make entire mechanical devices in place, without any assembly. Similarly, they have made a four-bladed propeller, 5mm in diameter.

Physics sets engineering challenge

Two of the World's largest superconducting magnets, for use in an international particle physics experiment, are to be designed and built by a team under the guidance of a scientist from the UK. Elwyn Baynham, the project leader from the CLRC Rutherford Appleton Laboratory and one of the World's experts on superconducting magnets, is to lead a team of engineers and scientists to design, construct and test a pair of massive toroidal magnets. These magnets will form a key part of the end cap detectors of the Atlas experiment on the large Hadron collider (LHC) currently being constructed at

the European particle accelerator laboratory at Cern in Geneva.

Over 30km of Rutherford cable will be used to form the coils of the magnet. The coils will operate at 4.5K – just above absolute zero – and the conductors will carry a current of 20,000A with zero power loss. The magnets will have a stored magnetic energy of over 400Mj – equivalent to the kinetic energy of an inter-city train at 125mile/h.

The huge scale and complexity of the finished product means that it will not be possible to build a prototype of the end caps,

so special modelling techniques involving finite element analysis and virtual reality simulations are being used to ensure that the design is feasible. When the design stage has been completed the components will be fabricated in industry to the defined specifications of the design team and finally assembled, integrated and commissioned into the detector at Cern.

When the Atlas detector has been completed it will be used by particle physicists worldwide to search for evidence of the Higgs Boson. The LHC is due to be switched on in July 2005. ■

COMPONENTS & SYSTEMS FROM IOSIS

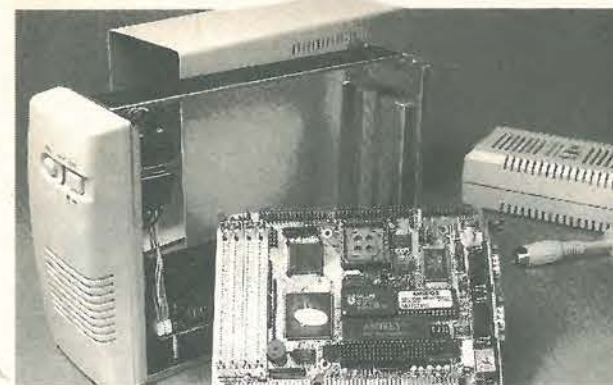

System Components from ISO9001 Source
Half Size Single Board Computers
386SX to Pentium with ISA and PC/104 Bus
2 Serial Ports, IDE, FDD & Printer Port
Flash/ROM Disc, Cache, SVGA CRT/Flat Panel Controller

PC/104 Modules
386 & 486 CPUs, Solid State Disc, Isolated RS232/485
VGA CRT/Flat Panel Display & SVGA Controllers
PCMCIA types I, II & III
Fast SCSI, Ethernet, Fax/Modem

System Enclosures with Passive Backplanes
System Integration and Support

All-In-One Standard Motherboards & Cases
486/586 to 200MHz Pentium

4 Somerton Rd, St Andrew
Bristol, BS7 9AA
Tel 0117 924 9231
Fax 0117 924 9233
E-mail: sales@iosis.co.uk



Details on our website <http://www.iosis.co.uk>

CIRCLE NO. 114 ON REPLY CARD

The Stereo Headphone Amplifier Box

Balanced or unbalanced line inputs to stereo headphone output

Professional portable units operating from an internal PP3 battery or external mains adaptor



*Precision transformerless differential left and right inputs
*Wide range of headphone drive impedances *High common mode rejection *Low noise and distortion *Low quiescent power consumption for extended battery life *Extensive RFI protection

The Balance Box (mic/line amplifier) - The Phantom Power Box - The OneStop DIN rail mounting radio frequency interference filter and voltage transient protector for voltage and current loop process signal lines

Conford Electronics Conford Liphook Hants GU30 7QW

Information line 01428 751469 Fax 751223

E-mail contact@confordelec.co.uk

Web <http://www.confordelec.co.uk/catalogue/>

CIRCLE NO. 115 ON REPLY CARD

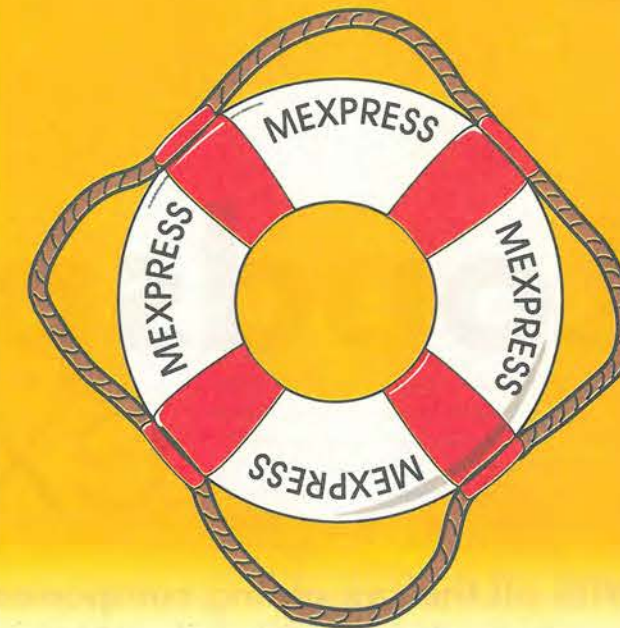

For the Busy Engineer

Use MExpress and you could wonder how you ever managed without it. Need to load some data and plot it as a stacked contour, surface plot, contour & image? No problem.



Great for data Visualisation and building Applications

Need to create an application to analyse and display sound files which you can distribute with your new hardware design? No problem. With over 250 built in functions covering numerical methods, signal processing, scientific & engineering style 2D/3D graphics you can build applications quickly & if you order the Developers Edition you can distribute your applications ROYALTY FREE! MExpress 1.1 Standard Edition (£99), Developers Edition (£299). Prices exclude P&P and VAT, the Developers Edition requires a C++ compiler (a wide range are supported).

***30 Day Money Back Guarantee**

***FREE Technical Support *FREE Upgrades for 12 months**

Tell me more!

Name

Address

Tel/Fax

 Quickroute Systems Ltd. Regent House
Heaton Lane Stockport SK4 1BS U.K.
Tel 0161 476 0202 Fax 0161 476 0505
www.quickroute.co.uk
© QSL1997

CIRCLE NO. 116 ON REPLY CARD

Loudspeakers exposed

With all the remaining components of an audio chain being increasingly refined, John Watkinson argues that the loudspeaker has become the limiting factor in audio quality. Here, he looks at the problems and presents solutions.

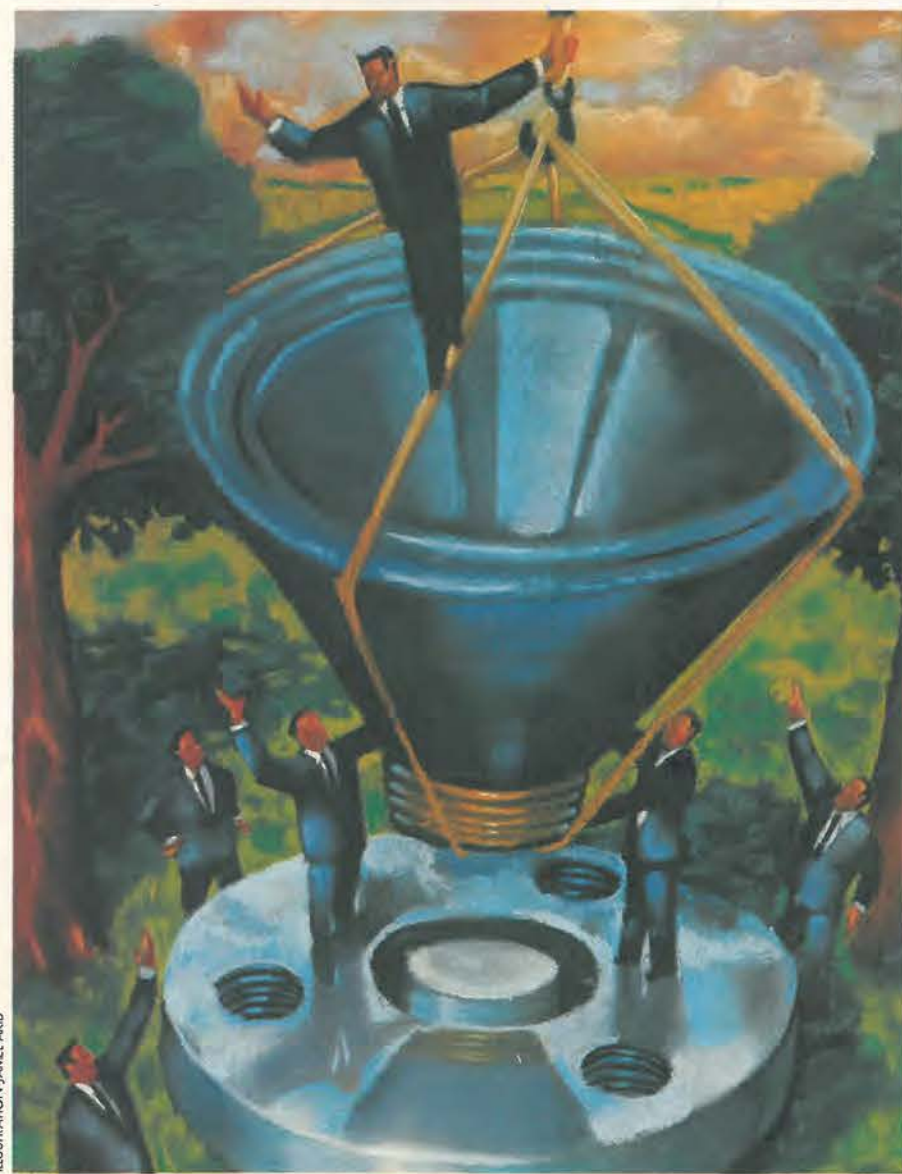

ILLUSTRATION JANEL AKB

Until recently, virtually every component in the audio chain was capable of causing audible impairment. If high quality was the goal a degree of determination and plenty of time was needed to adjust equipment to a finely balanced point faster than it drifted. Because things were never good enough there was a consistent research effort and this has given tangible results.

In a typical modern audio system, a microphone feeds an a-to-d converter, connected to a digital recorder, driving a d-to-a converter, a power amplifier and a loudspeaker. At some point a mixing console may be found. The weakest link determines the overall quality.

Modern microphones have an extremely flat frequency response, and adequate dynamic range and linearity. Modern converters using noise shaping and oversampling with 18 and 20-bit resolution are outperforming our ears, — provided some attention is given to clock jitter.

If a digital audio recorder uses digital i/o, then provided it doesn't use compression, it doesn't have a sound quality. Numbers coming in are the same as numbers going out. High quality modern mixing consoles have reached a stage where they are virtually transparent. Power amplifiers have reached a state where further developments will be in the area of efficiency and the friendliness of the load presented to the ac supply.

Most of the quality loss in a modern sound reproduction system is due to the loudspeakers, which for some reason have not seen the development of other components. In my opinion loudspeakers are now causing a quality bottleneck. Such an area is ripe for research because for a given effort the rewards will be more significant in comparison with more mature technologies where the returns diminish as the ideal is approached.

I should stress that I am interested in precise sound reproduction rather than in hi-fi. There was a time when the two were synonymous, but nowadays in many respects hi-fi has become a religion in which beliefs are more important than truths and enthusiasm replaces knowledge. The temples of hi-fi are the phenomenally expensive hardware installations and the high priests are journalists who find pseudo-scientific reasons to make the believers feel comfortable with the vast sums they have spent.

The laws of physics involved in audio reproduction are established beyond any shadow of a doubt yet they are regularly called into question by hi-fi journalists whose ejaculations usually serve only to raise the noise floor for the genuine researcher.

It is impossible to make other than accidental or empirical progress without a clear picture of the processes involved and an understanding of the key criteria. To determine what part of one's knowledge base can be trusted it is necessary to remove from it all of the myths and pseudo science and to establish what is and is not the case. It is surprising how long this takes if one is to be impartial and scientific about every spurious theory.

"The laws of physics involved in audio reproduction are established beyond any shadow of a doubt yet they are regularly called into question"

Without a knowledge of psycho-acoustics it is impossible to assess the relative merits of differing approaches. The human hearing system is complex and highly sensitive in some areas, yet surprisingly casual in other areas. If this is understood, precision will be placed in areas of sensitivity, whilst shortcomings can be mitigated by placing them in other areas.

As audio systems are designed for human listeners, the criteria for audio quality can only be subjective. Audio systems form a window between the listener and the original sound. All that is necessary is to make that window larger than the sound passing through it in all respects. If human listeners are unable to detect an impairment, then the quality is sufficient and the window is big enough. Making it even bigger simply drives up the cost.

Listening tests are vital once all objective tests have been passed, but in order to be significant, such tests have to be properly con-

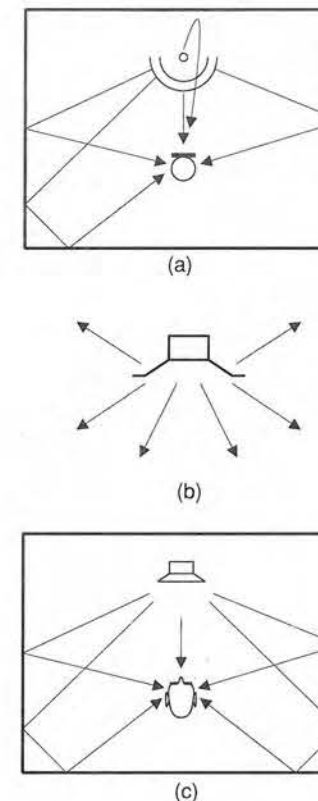

Fig. 1a) Sound approaches microphone from many directions due to ambience and reverberation. b) In anechoic conditions a single loudspeaker produces exactly the opposite of a). c) Loudspeaker in reverberant conditions simulates situation of a) at listener's ears.

ducted to avoid bias. I can listen to a loudspeaker as well as anyone, but unlike many, I do not consider myself competent to do so alone. This is simply because the spread of human hearing performance is so great that I cannot be truly representative. I will naturally listen to my own designs more favourably than those of others.

In a significant listening test, neither the operator nor the subjects must be aware of the reason for the tests, and the design of the tests must be approved by a statistician who can determine how likely it is that identical results could have been obtained by chance. I can only listen to a loudspeaker of my own design to ensure that it has no obvious warts, but to compare it meaningfully with another speaker of similar performance is beyond any individual.

The ideal

An ideal speaker might be one which was a sphere whose volume changed according to the input waveform. Such a device would

behave as an ideal point source, having frequency independent dispersion and a frequency response like a ruler. What is more it would be perfectly linear and would not exhibit energy storage, which would also make it perfectly phase linear.

Some of these consequences bear explanation. A pulsating sphere acts as a point source because wherever one stands, the part of the surface nearest is moving directly towards and away from one. All points on the surface move in the same phase, therefore there can be no vibrations propagating across the surface of the sphere. Consequently there is no requirement to suppress such vibrations. Radiation cannot occur after the input ceases. If the output stops when the input stops, the system is phase linear.

A good microphone produces an accurate version of sounds approaching it from many directions. Even if a loudspeaker reproduced the microphone waveform exactly, the resulting sound is leaving in many directions. Spatially, a single loudspeaker is producing sound travelling in exactly the opposite direction to the original. Consequently reproduction of the original sound field is simply not possible.

Figure 1 shows the problem. Sound approaching a microphone at a) does so from a multiplicity of sources whereas sound leaving a single loudspeaker superimposes all of these sources into one. Consequently a monophonic or single loudspeaker is doomed to condense every sound source and its reverberation to a single point.

When listening in anechoic conditions b) this is exactly what happens. While the waveform might be reproduced with great precision, the spatial characteristics of such a sound are quite wrong.

However, when listening in a room having a degree of reverberation, a better result is achieved irrespective of the reverberation content of the signal. The reverberation in the mono signal has only time delay and no spatial characteristics whatsoever whereas the reverberation in the listening room has true spatial characteristics. The human listener is accustomed to ambient sound approaching from all directions in real life and when this does not happen in a reproduction system the result is unsatisfactory.

Thus in all real listening environments a considerable amount of reverberant sound is required in addition to the direct sound from the loudspeakers. Figure 1c) shows that the reverberation of the listening room results in sound approaching the listener from all sides giving a closer approximation to the situation in a). Clearly better reverberation will be obtained when the loudspeaker is out in clear space in the room. So-called bookcase loud-

speakers mounted on walls or shelves can never give good results.

Better spatial accuracy requires more channels and more loudspeakers. While the ideal requires an infinite number of loudspeakers, with care, as few as two speakers can give a convincing spatial illusion. The improvement in spatial performance using two speakers is enormous. Tests have shown that most people prefer stereo with poor bandwidth and significant distortion to pristine mono.

Two speakers can only give spatial accuracy for sound sources located between them. Reverberation in the listening room then provides ambient sound from all remaining directions. Clearly the resultant reverberant sound field can never be a replica of that at the microphone, but a plausible substitute is essential for realism and its absence results in an unsatisfactory result. This renders the traditional use of heavily damped rooms for monitoring suspect.

If realism is to be achieved, the polar diagram of the loudspeaker and its stability with frequency are extremely important. A common shortcoming with most drive units is that output becomes more directional with increasing frequency. Fig. 2a shows that although the frequency response on-axis may be ruler flat giving a good quality direct sound, the frequency response off-axis may be quite badly impaired as at b). In the case of a multiple drive unit speaker, if the crossover frequency is too high, the low-frequency unit will have started beaming before it crosses over to the tweeter which widens the directivity again.

The figure shows that the off-axis response is then highly irregular. As the off-axis output excites the essential reverberant field the tonal balance of the reverberation will not match that of the direct sound. The skilled listener

"If realism is to be achieved, the polar diagram of the loudspeaker and its stability with frequency are extremely important."

can determine the crossover frequency, which by definition ought not to be possible in a good loudspeaker.

The resultant conflict between on- and off-axis tonality may only be perceived subconsciously and cause 'listening fatigue', where the initial impression of the loudspeaker is quite good but after a while one starts looking for excuses to stop listening.

The hallmark of a good loudspeaker installation is that one can listen to it indefinitely. Unfortunately such instances are rare. More often loudspeakers are used having such poor off-axis frequency response that the only remedy is to make the room highly absorbent so that the off-axis sound never reaches the listener. This has led to the well-established myth that reflections are bad and that extensive treatment to make a room dead is necessary for good monitoring. This approach has no psychoacoustic basis and has simply evolved as a practical way of using loudspeakers having poor directivity.

The problem is compounded by the fact that an absorbent room requires more sound power to obtain a given sound-pressure level. Consequently heavily treated rooms require high-power loudspeakers which have high dis-

tortion and often further sacrifice polar response in order to achieve that high power.

A conventional box shaped loudspeaker with drive units in the front will suffer extensive shading of the radiation to the rear and thus will create a coloured reverberant field. Clearly a much more effective way of exciting reverberation with an accurate tonal balance is for the loudspeaker to emit sound to the rear as well as to the front. This is the advantage of the dipole loudspeaker which has a figure-of-eight polar diagram.

Loudspeakers have also been seen with additional drive units facing upwards in order to improve the balance between direct and reverberant sound. These techniques work well but obviously in a dead room are a waste of time as the additional radiation will never reach the listener. The fault is in the room, not the speaker.

Air is not very dense. As a result it is not possible to influence very much mass at once. Thus it is difficult to radiate energy into air with a mechanical device because the mass of the moving part of that device will eclipse the mass of air influenced. In engineering terms a diaphragm has a high mechanical impedance but the air has a low impedance, resulting in a mismatch, meaning that loudspeakers will always be inefficient. With the almost limitless power from modern amplifiers this is a minor problem.

As an alternative the horn loudspeaker is a kind of acoustic transformer which raises the impedance of the air adjacent to the diaphragm in order to improve the power transfer. Unfortunately, acoustic transformers are difficult to make linear and the resulting distortion is difficult to eliminate.

A great problem with loudspeaker design is the span of wavelengths involved. These range

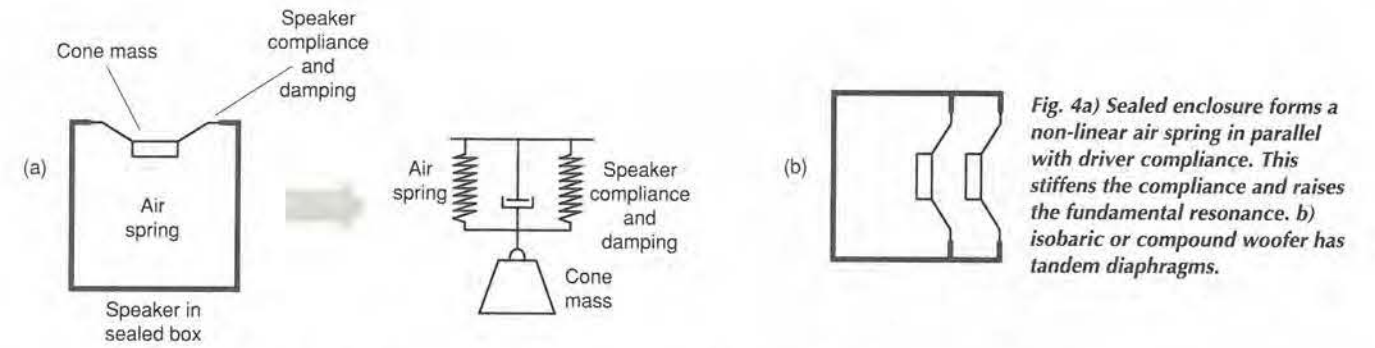
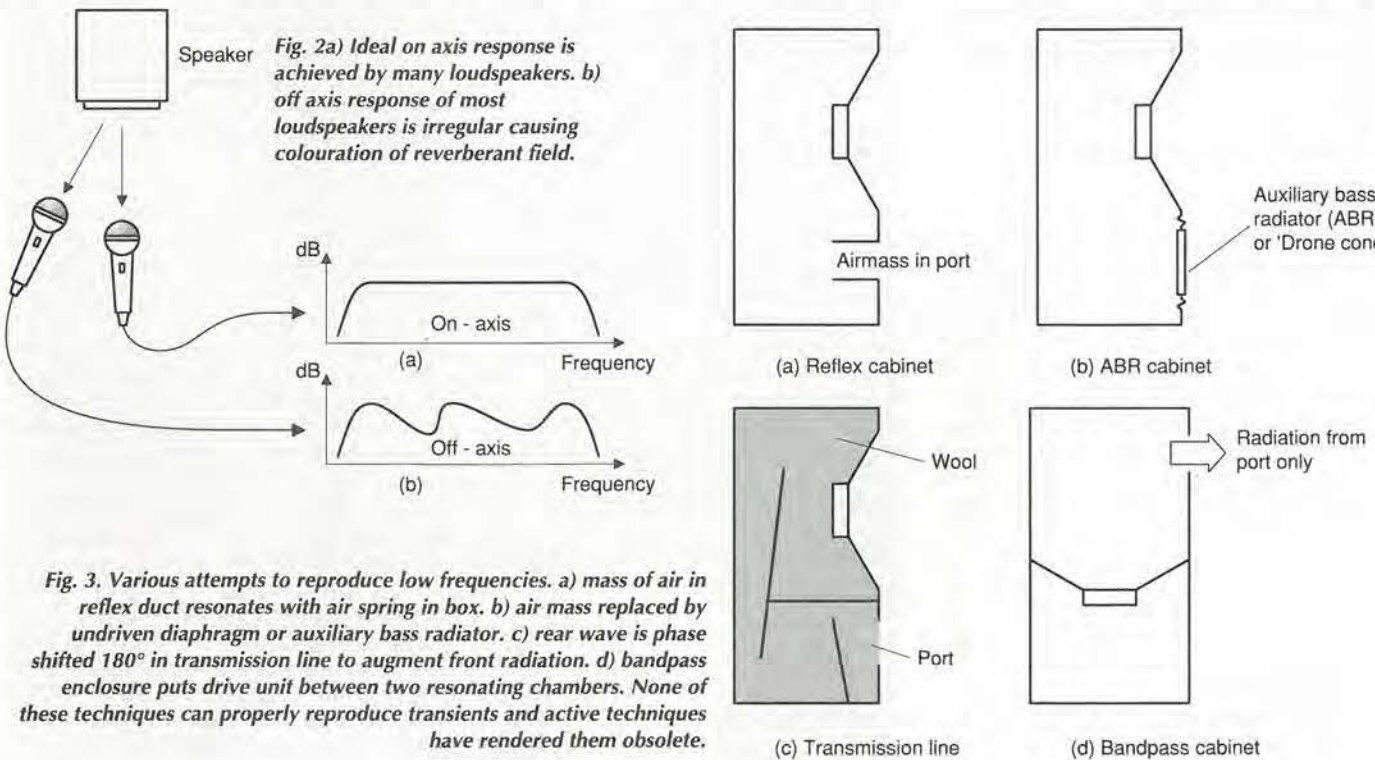

from a few millimetres at the highest audible frequency to several metres at the lowest. There cannot be many disciplines in which mechanical motion is required over such an octave range.

Wave theory is dominated by the relative sizes of the source and the wavelength. Thus in a loudspeaker at the highest frequencies the transducer is much larger than the wavelength, whereas at the lowest frequencies it is much smaller. As a practical matter it is necessary to use more than one drive unit with a crossover network.

Reproducing low frequencies

In order to allow a diaphragm to generate low frequencies, it must be provided with an enclosure which prevents an acoustic short circuit. Provided the wavelength is larger than the enclosure, the resulting radiation will be omnidirectional and the result will be exactly the same as if a pulsating sphere had been used.

The lowest frequency to be reproduced is debatable and depends upon the material to be reproduced. If we want to be able to reproduce all musical instruments, we have to include the organ. Organ pedal notes don't start to be realistic unless a response is maintained to around 20Hz. At this frequency you do some of your listening with your chest - even at moderate sound-pressure levels. Low-frequency roll-off is unavoidable, but it must be monotonic and preferably have a slope of no more than 12dB/octave.

Most loudspeakers cannot faithfully reproduce the input waveform at low frequencies, but unless this is done, a loudspeaker is simply not accurate enough. An obvious example is the transient when an organ pipe begins to speak or stops speaking. The sound is distinctive and a good loudspeaker should reproduce it - but most don't. Further examples include marimbas and other bass percussion instruments like hollow logs.

Many loudspeakers employ resonances to obtain an extended frequency response in the mistaken belief that only steady state frequency response is important, Fig. 3. By definition, resonance works by storing energy. This energy is taken from the leading edge of a bass transient and added to the trailing edge. Again by definition a tuned loudspeaker cannot be phase linear. Consequently transient edges are blurred and unrealistic and arrive out of time with the treble energy. The correct term is linear distortion.

Therefore reflex loading, the auxiliary bass radiator and its more recent relative the bandpass enclosure, are unacceptable on fidelity grounds. These all achieve a lower frequency steady state response by destroying the waveform of bass transients. They have a steeper roll-off below resonance which is unnatural. The transmission line loudspeaker fails because there is an assumption that a phase shift in the line is as good as an inversion. Again this is unfortunately only true on continuous sinewave.

Reflex, auxiliary bass radiator, transmission line and bandpass enclosures are all traditional approaches which were the best that could be done with the simple electronics of the day. The active loudspeaker, which can easily be made phase linear, renders all of these approaches obsolete except for economy or to get high sound-pressure with old fashioned magnet technology. The only published techniques which do not violate the ideal are the sealed enclosure and its relative the isobaric. Untuned loudspeakers which do not store energy are essential for high fidelity because they can be made phase linear.

With a traditional approach to the sealed enclosure, the optimal reproduction of low frequencies requires a physically large loudspeaker. The mass of the diaphragm and the stiffness of the air in the enclosure behind it form a resonant system, as Fig. 4 shows. Below resonance there is little output and so the lower the resonant frequency the better.

The smaller the cabinet, the higher the stiffness of the air within, and the higher the fundamental resonance. Also the internal pressures generated rise with small cabinets, resulting in a large force on the diaphragm and an increased likelihood of breakup. This is where the isobaric configuration scores by isolating the outer driver from the enclosure pressure.

"While it is well known in engineering that pressure containment vessels should be cylindrical or spherical, loudspeaker designers cling to the rectangular box."

The resonant frequency can be lowered by raising the diaphragm mass, but that reduces the efficiency too, causing a coil dissipation problem. The force on the diaphragm can be reduced by using a smaller diameter, but then the throw has to be increased, increasing distortion. Thus if a good low-frequency response and low distortion is required at reasonable sound-pressure levels, the traditional loudspeaker has to be large.

In strictly theoretical terms, a low-frequency loudspeaker only needs to be able to displace a sufficient volume of air to achieve the required sound-pressure level, and this has nothing to do with its enclosure volume. Thus in principle at least, a small low-frequency loudspeaker is possible, but this will not be based on the conventional approach and it will not be passive. With active techniques the motion of the diaphragm and its apparent resonant frequency are under the control of the amplifier designer.

Clearly a loudspeaker cabinet must be totally inert. As the interior of the cabinet is driven by a secondhand signal from the back of the drive units, there is no way that this can be allowed to radiate. As the area of the enclosure walls eclipses the area of the diaphragm, even small enclosure vibrations can have a serious effect on clarity.

While it is well known in engineering that pressure containment vessels should be cylindrical or spherical, loudspeaker designers cling to the rectangular box. The flat panels of a box are easy for carpenters to assemble, and eliminate the need for spending money on industrial design. But from any acoustic standpoint, they are inadequate. Has anyone ever seen a square submarine or a rectangular aerosol can?

Reproduction at higher frequencies

When a plane diaphragm transducer is much larger than the wavelength, it tends to produce plane waves which are directional. In the case of an unenclosed diaphragm, a bipolar response is achieved in which the front and rear radiations are identical but anti-phase.

Directionality rises with frequency and the result is that the highest frequencies can only be discerned directly on axis. As has been seen, this result is unacceptable and in a well engineered tweeter steps must be taken to avoid it.

At high frequencies, the cone acts as a mechanical transmission line for vibrations which start at the coil former and work out-

New Pico virtual instruments

15% reader discount

The new ADC-40 and -42 virtual instruments from Pico turn your pc into a 20kHz (15kHz for ADC-42) sampling digital oscilloscope – with non-volatile storage.

As an exclusive introductory offer, Pico Technology in conjunction with *Electronics World* is making the single-channel ADC-40 and -42 available to readers at £51.31 and £73.92 excluding VAT and p+p. Normally, the ADC-40 is £59, while the ADC-42 is £85.

ADC-40/42 instrumentation

Used with the ADC-40/42, your computer becomes a 20/15kHz sampling single-channel:

- digital storage oscilloscope
- spectrum analyser
- voltmeter
- frequency meter

What is more, instrument functions can be displayed simultaneously.

With the ADC-40/42 running as an oscilloscope, you can monitor a waveform's shape, frequency, amplitude and dc offset with advanced triggering facilities. In addition, you have almost unlimited digital storage capability and infinite persistence for glitch capture.

This is a low-cost, low-frequency oscilloscope. But, using the pc as a control interface, its display, storage, printing and processing features outperform those of almost all benchtop oscilloscopes. You can even import captured waveforms into your documents.

Voltage of a waveform is displayed directly, unlike a conventional oscilloscope, where voltage has to be derived from graticule divisions. Chart-recorder mode makes viewing of slow waveforms easy.

All the storage and display features are available with the spectrum analyser function. These include pre and post triggering in 1% steps. Seven window types are possible, together with signal averaging and all the trigger functions available in oscilloscope mode. And rulers are available for amplitude and frequency measurements.

In addition, you have a true rms voltmeter with decibel range, and a frequency meter capable of reading to 5kHz. Data-logging software is available for an extra £10 if purchased with an ADC40 or 42.

All instrument functions are easy to use and feature on-line help.

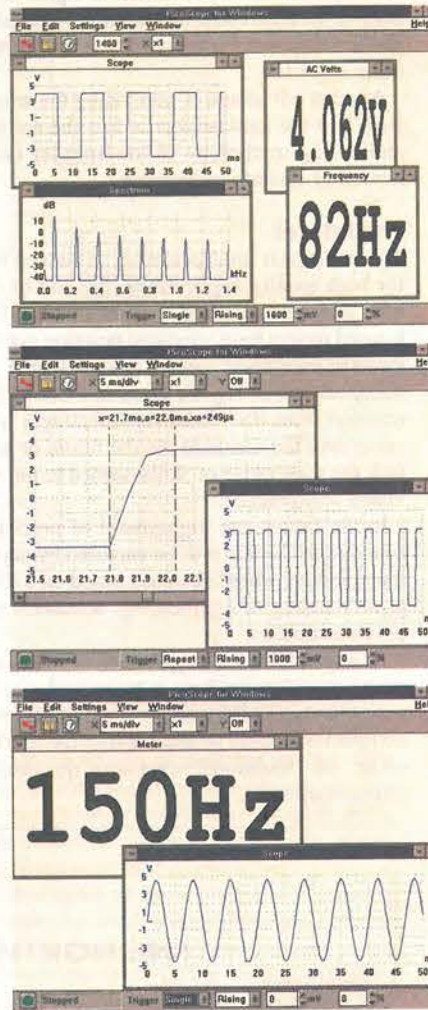

ADC-40/42 single channel oscilloscopes

- Low cost and easy to use
- No power supply required
- Ultra compact design
- Data logging software available
- Write-to-disk on trigger function standard

The ADC-40 and ADC-42 are single-channel pc based virtual instruments. Simply plug the unit into the parallel port of your pc and run the software. Designed for analysing low-frequency signals, both units provide all the functionality of conventional scopes at a fraction of the price.

The ADC40 has 8-bit resolution and is suitable for a wide range of dc and ac measurements and analyses. Resolution of the ADC-42 is 12 bits, making it more suitable for applications where detection of small signal changes is needed.

Scope timebases	500µs/div to 50s/div
Spectrum analysis	100Hz to 10kHz
Max sampling	20ksample/s
Voltage ranges	±5V
Resolution	8 bit for ADC40 12 bit for ADC42

Channels	1 BNC
I/P impedance	1MΩ, dc coupled
Accuracy	1%
PC connection	D25 to PC parallel port
Power supply	No power supply required

Use this coupon to order your ADC40/42 (max 3 per coupon)

Please send me ADC-40(s) at the special offer price of £67.34 each or ADC-42(s) at £93.91. Note that both prices include VAT and recorded UK delivery. (UK P+P is £6 exc VAT).

Name

Company (if any)

Address

Phone number/fax

Total amount £.....

Make cheques payable to Reed Business Information Group. Or, please debit my Master, Visa or Access card.

Card type (Access/Visa)

Card No

Expiry date

Please mail this coupon to Electronics World, together with payment. Alternatively fax credit card details with order on 0181 652 8111. You can also telephone your order on 0181 652 3614, but only Mondays, Tuesdays or on Friday mornings. Address orders and all correspondence relating to this order to Pico, Electronics World, Quadrant House, The Quadrant, Sutton, Surrey SM2 5AS.

electronicsWEEKLY

HYPERACTIVE

CONNECT WITH THE UK'S NO 1 READ FOR ELECTRONICS PROFESSIONALS ON THE INTERNET



CAREERS

- Daily News Service – this section is updated daily from news sources around the world. So keep coming back to keep abreast of developments in the global electronics industry.
- Technology Updates
- Fully Searchable online database to Electronics Weekly's high quality editorial
- On-line Jobs service and careers advice – see the latest jobs on offer



DAILY NEWS



TOOLKIT



INSIDE VIEW



ARCHIVE



TECHNOLOGY



TOSHIBA

Sponsored by:

Point your browser at

<http://www.electronicweeky.co.uk/>

and register now (it's free)

MExpress Up to 44%

Announcing MExpress for Windows

Think of it as Basic for engineers and scientists.

MExpress has the interactive ease of use of Basic, but with the extensive and powerful 32bit functionality of a modern scientific & engineering development tool.

The package is essentially a means of helping scientists and engineers to visualise complex data by representing it in pictorial form.

It includes over 250 functions covering everything from solving simultaneous equations and signal processing, to advanced 3D plotting and creation of user interfaces.

Until 1 August, Quickroute Systems is offering MExpress exclusively to *Electronics World* readers at special prices of £79 fully inclusive for the Standard Edition and £199 for the Developers Edition – fully inclusive of VAT, packing and UK post. This represents discounts of 35% and 44% respectively.

The exclusive rrp for MExpress Standard Edition is £99 while the Developers Edition £299.

The Developers Edition requires a C++ compiler which can be Symantec® C++ 7.2, Microsoft® Visual C++ 2.0, or Borland® C++ 5.0.

Please contact Quickroute Systems at Regent House Heaton Lane Stockport SK4 1BS UK for further details. Tel 0161 476 0202 Fax 0161 476 0505 EMail info @quicksys.demon.co.uk WWW http://www.quickroute.co.uk

**** For a free information pack, call Quickroute at the number above. ****

Plus:

- 30-day money back guarantee
- Free technical support
- Free upgrades for 12 months.

discount

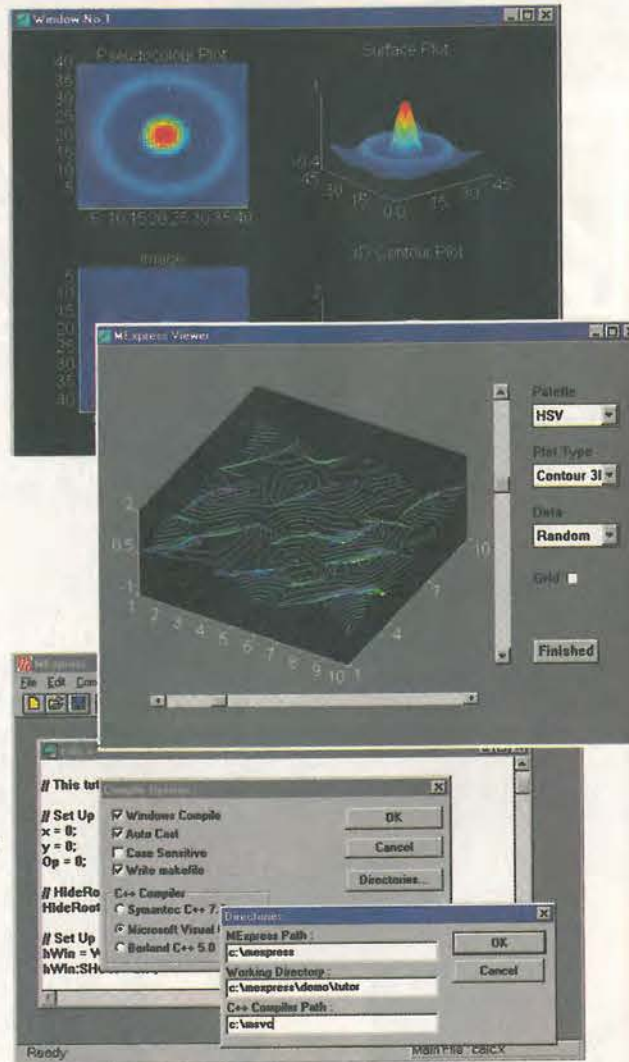

Minimum system requirements: 386, 8M ram, Windows 3.1, '95 or NT. Coprocessor not essential.

MExpress – Features
MExpress can be used as a "super charged graphing calculator", by simply typing commands and expressions at a familiar prompt. Data can be loaded, processed, and plotted or visualised by calling on the powerful built-in functions. Once you are happy with basic commands, you can move on to create simple script

files. These are lists of commands – similar to batch files. You can also create functions and in turn complete applications with buttons, sliders, menus, multiple windows, etc. If you are using the Developers Edition of MExpress, the applications can be compiled into a Win32s executable which can be distributed – royalty free.

Use this coupon to order MExpress

Please send me copies of MExpress 1.1 Standard edition at the fully inclusive price of £79 or copies of MExpress 1.1 Developers' edition at the fully inclusive price of £199.

Name

Company (if any)

Address

Phone number/fax

Total amount £.....

Make cheques payable to Quickroute Systems Ltd
Or, please debit my Master, Visa or Access card.

Card type (Access/Visa/Switch/Visa Delta)

Card No

Expiry date

Signature

Please mail this coupon to Quickroute Systems, together with payment. Alternatively fax credit card details with order on 0161 476 0505 or telephone on 0161 476 0202. Address orders and all correspondence relating to this order to Quickroute at Quickroute Systems Ltd, Regent House, Heaton Lane, Stockport SK4 1BS.

*Overseas readers can also obtain this discount but details vary according to country. Please ring, write or fax to Quickroute for details.

ELECTRONICS WORLD

+ WIRELESS WORLD

Electronics World+ Wireless world is applied electronic design. We'll show you how to use the latest silicon technology plus...

- ✓ CAE software
- ✓ New product reviews
- ✓ Technology reports
- ✓ Detailed circuit diagrams
- ✓ Innovations
- ✓ Explanations of complex technology
- ✓ Comment and much more in your issue.

So whether you are designing your own system or curious about your competitors *Electronics World + Wireless World* will help you keep the leading edge.

Money back Guarantee.
Receive a full refund on your subscription within the first 90 days if you are not completely satisfied. Thereafter, we'll refund the unused portion of your subscription should you wish to cancel.



SAVE UP TO 10%

Grundig CS4040 Scope	£125.00
Hewlett Packard Scanjet	£95.00
Hewlett Packard 8407A Network Analyser with 8412A	£450.00
Racal Inst. 9915 UHF Freq. Meter 500 MHz	£90.00
Racal Inst. 9916 UHF Freq. Counter 500 MHz	£130.00
Leader LMV 181A AC Millivoltmeter	£130.00
Hewlett Packard 239A Oscillator	£125.00
Wavetek Model 185 Function Gen	£160.00
Farnell PSU 0-70VDC 0-5A/0-30 VDC 0-10A	£225.00
Marconi AM/FM Sig=Gen-2002B 88MHz	£150.00
AVO RM 215/L2 AC/DC Breakdown Tester	£250.00
Philips PM5171 AMP/LOG Converter	£100.00
PSI A100 Waveform Gen=	£200.00
Krohn-HITE 3343 Filter	£100.00
Racal 9902 Counter	£70.00
Hewlett Packard 415E SWR Meter	£75.00
Hewlett Packard 3551A Transmission Test Set	£160.00
Hewlett Packard 5004A Signature Analyser	£75.00
Philips PM 6611 Universal Counter 80 MHz	£90.00
Hewlett Packard 5300B Measuring System with 5312A HP-IB Interface 1.3 GHz	£225.00
Weir 761-1 Bench PSU	£117.00
Ortec Brookdeal Phase Sensitive Detector 9412 Ref Unit 9422	£140.00

PLEASE RING FOR 7000 SERIES SCOPES + PLUG IN'S
OVERSEAS ENQ. WELCOME
TELEPHONE ORDERS ACCEPTED
C/P DETAILS PLEASE RING. ALL PRICES PLUS 17.5% VAT

CIRCLE NO. 120 ON REPLY CARD

Measurably better value



Function generator
£239 + vat



and
nts
or money.
s are available including bench
meters, counters, logic analysers,
trium analysers and more.

All TTI products are designed and manufactured here in the U.K. and are backed by a level of quality and technical support that few competitors can match.

For details and prices of the full TTI range, contact our sales desk or circle the reply number.

TTI
Measurably better value

Thurlby Thandar Instruments Limited
Glebe Road, Huntingdon, Cambs. PE18 7DX
Tel: 01480 412451, Fax: 450409, e-mail: sales@ttinst.co.uk

THURLBY THANDAR INSTRUMENTS

MExp Up to

Announcing MExp

Think of it as Basic for e

MExpress has the interactive ease of a powerful 32bit functionality of a mode development tool.

The package is essentially a means to visualise complex data by representing it includes over 250 functions covering simultaneous equations and signal processing creation of user interfaces.

Until 1 August, Quickroute Systems is offering *Electronics World* readers at special price Standard Edition and £199 for the Developers Edition and UK post. This represents the exclusive rrp for MExpress Standard Developers Edition £299.

The Developers Edition requires a C++ 7.2, Microsoft® Visual C++ 2.0, Please contact Quickroute Systems at SK4 IBS UK for further details. Tel 016 EMail info@quicksys.demon.co.uk W

** For a free information pack, call

Use this coupon to order MExp

Please send me copies of MExp edition at the fully inclusive price of £199. MExpress 1.1 Developers' edition at price of £199.

Name

Company (if any)

Address

Phone number/fax

Total amount £.....

Make cheques payable to Quickroute Systems Ltd Or, please debit my Master, Visa or Access card.

Card type (Access/Visa/Switch/Visa Delta)

Card No

Expiry date

Signature

Please mail this coupon to Quickroute Systems, together with payment. Alternatively fax credit card details with order on 0161 476 0505 or telephone on 0161 476 0202. Address orders and all correspondence relating to this order to Quickroute at Quickroute Systems Ltd, Regent House, Heaton Lane, Stockport SK4 1BS.

*Overseas readers can also obtain this discount but details vary according to country. Please ring, write or fax to Quickroute for details.

EW97A

Yes, I would like to subscribe to Electronics World + Wireless World.

1 Year UK £32 Europe £46 Rest of world £56
2 Years UK £58 **SAVE 10%** Europe £83 **SAVE 10%** Rest of world £101 **SAVE 10%**

Name _____
Job Title _____
Company _____
Address _____
Post Code _____
Telephone _____
Country _____
Fax _____
Internet Address _____

THREE WAYS TO PAY

1 I enclose a cheque made payable to Electronics World + Wireless World for £ _____
2 Please charge my Mastercard/Access/Visa/Diners Club/American Express (please delete appropriate card) with the sum of £ _____
3 Please invoice me/my company. Purchase order number _____
Company VAT registration number _____
Please allow 28 days for delivery of your first issue.

Card number _____
Signed _____
Expiry Date _____
Date _____

Please tick here if you do not wish to receive direct marketing promotions from other companies.

041

Post in the UK to Electronics World Subscriptions, FREEPOST RCC 2619, PO Box 302, Haywards Heath, RH16 3BR. Telephone 01444 445566

Post from elsewhere to Electronics World Subscriptions, PHQ-D/1700/IRH, PO Box 302, Haywards Heath, RH16 3BR, UK. Telephone +44 1444 445566

MExpress can be used as a "super charged graphing calculator", by simply typing commands and expressions at a familiar prompt. Data can be loaded, processed, and plotted or visualised by calling on the powerful built-in functions. Once you are happy with basic commands, you can move on to create simple script commands - similar to batch files. You can also create functions and in turn complete applications with buttons, sliders, menus, multiple windows, etc. If you are using the Developers Edition of MExpress, the applications can be compiled into a Win32s executable which can be distributed - royalty free.



“Following just one year's advertising, our customer base has increased by 55% in the UK”
Mr. P Hart W E Couplings & Coatings

Over 332,000 buyers are using the **UK Kompass Register** every day to find companies like yours.

Is it you they're finding or your competitors?

Call now to appear in the next edition.
0800 521393
Please quote reference UKK 1

CIRCLE NO. 119 ON REPLY CARD

Field Electric Ltd.
Tel: 01438-353781 Fax: 01438 359397
Mobile: 0836-640328
Unit 12b, Parsons Green Ind. Est.
Bolton Road, Stevenage, Herts SG1 4QQ

14" Colour VGA Monitors various 1st brand makes	£60.00
Sony 9" RGB Colour Monitors (Trinitron)	£39.00
14" SVGA 1st Brand Makes from	£95.00
Hewlett Packard 334A Distortion Analyser	£120.00
Calcomp 81 Plotter (Digitizing)	£90.00
Hewlett Packard 5345 A Counter	£995.00
Tektronic/Sony 308 Data Analyser	£650.00
Hauptage Win/TV Card 16 bit ISA card	£40.00
Gould SG200 RF SIG GEN	£125.00
Gould OS4000 10 MHz Scope (Parts)	£70.00
Hewlett Packard 7470A Plotter RS232 8 Pen	£75.00
Hewlett Packard Colour Pro Plotter RS232 8 Pen	£75.00
Hewlett Packard 7475A Plotter RS232 6 Pen	£70.00
Hewlett Packard 7550A Plotter HP-IB RS232 etc	£155.00
Gould OS4040 Scope	£125.00
Hewlett Packard Scanjet	£95.00
Hewlett Packard 8407A Network Analyser with 8412A	£450.00
Racal Inst. 9915 UHF Freq. Meter 500 MHz	£90.00
Racal Inst. 9916 UHF Freq. Counter 500 MHz	£130.00
Leader LMV 181A AC Millivoltmeter	£130.00
Hewlett Packard 239A Oscillator	£125.00
Wavetek Model 185 Function Gen	£160.00
Farnell PSU 0-70VDC 0-5A/0-30 VDC 0-10A	£225.00
Marconi AM/FM Sig=Gen-2002B 88MHz	£150.00
AVO RM 215/L2 AC/DC Breakdown Tester	£250.00
Philips PM5171 AMP/LOG Converter	£100.00
PSI A100 Waveform Gen=	£200.00
Krohn-HITE 3343 Filter	£100.00
Racal 9902 Counter	£70.00
Hewlett Packard 415E SWR Meter	£75.00
Hewlett Packard 3551A Transmission Test Set	£160.00
Hewlett Packard 5004A Signature Analyser	£75.00
Philips PM 6611 Universal Counter 80 MHz	£90.00
Hewlett Packard 5300B Measuring System with 5312A HP-IB Interface 1.3 GHz	£225.00
Weir 761-1 Bench PSU	£117.00
Ortec Brookdeal Phase Sensitive Detector 9412 Ref Unit 9422	£140.00

PLEASE RING FOR 7000 SERIES SCOPES + PLUG IN'S
OVERSEAS ENQ. WELCOME
TELEPHONE ORDERS ACCEPTED
C/P DETAILS PLEASE RING. ALL PRICES PLUS 17.5% VAT

CIRCLE NO. 120 ON REPLY CARD

June 1997 ELECTRONICS WORLD

**measurably
better value**



20MHz function generator
TG120 - £239 + vat

1.3GHz hand-held counter
PFM1300
£99 + vat



The TTi range of test and measurement instruments offers unrivalled value for money.

More than 60 products are available including bench power supplies, multimeters, counters, logic analysers, signal generators, spectrum analysers and more.

All TTi products are designed and manufactured here in the U.K. and are backed by a level of quality and technical support that few competitors can match.

For details and prices of the full TTi range, contact our sales desk or circle the reply number.



Measurably better value

Thurlby Thandar Instruments Limited
Glebe Road, Huntingdon, Cambs. PE18 7DX
Tel: 01480 412451, Fax: 450409, e-mail: sales@ttinst.co.uk

THURLBY THANDAR INSTRUMENTS

A look at LIGHT

Light emitting diodes have improved enormously, in both efficiency and brightness, over the years. I recall obtaining a sample of one of the first leds - red, of course - to become available, around 1970. This Texas Instruments device came in a single lead can, with glass window, smaller than TO18, the can itself being the other lead.

It was a great novelty to see a wee red light coming out of a solid. But as a replacement for a conventional panel indicator lamp, it was far too dim.

Since then, TI has continued to be a major force in opto products, several of these having been featured in articles in this magazine.^{1,2,3} But many other manufacturers are active in the field, which covers not only leds, photodiodes and phototransistors, but optocouplers, laser diodes, fibre-optic data products and other devices.

Light-emitting diodes in particular have seen major advances recently. Being fortunate enough to obtain samples of a number of the latest types, I was interested in finding out just what they will do, and exploring ways of applying them.

With the aid of his new light meter design, Ian Hickman has been investigating the properties of some of the more recent opto devices around.

Applications a-plenty

Light-emitting diodes are available covering the whole spectrum, from infra red to blue, and have a variety of uses. Infra-red types are used - commonly in conjunction with a photodiode fitted with a filter blocking visible light - in tv remote controls, and in infra-red beam intruder detectors, etc.

High-intensity red leds are now commonly employed as cycle rear lights, in place of small incandescent filament lamps. They are also suitable as rear lights for vehicles. Amber high-intensity leds are used as turn indicators or flashers.

Blue leds were for a long time unavailable. When they did appear they were much less bright than devices of other colours. But now, really bright blue leds are in production. A typical application is as one of the primary colours in large colour advertising displays. A good example is the Panasonic LNG992CF9 blue led in a T1³/₄ package. Surface-mount types are also available. It provides a typical brightness of 1400mcd over a ±7.5° angle, at a modest forward current of 20mA.

While most leds produce incoherent light, covering a range of wavelengths around the predominant frequency, special types operate as lasers, producing essentially monochromatic light. The result is a beam with very low dispersion. Uses include laser pointers as aids to visual presentations, and as read and write sources in optical disk products.

Panasonic produces laser diodes, but these are not at present marketed in the UK. They are intended for use in consumer products and hence available only in production quantities. Alas, there seems to be no manufacturer of cd players in this country.

Measurements are a must

In any branch of engineering - or science in general - little if any progress can be

made without suitable measuring instruments.

For my experiments with opto, I needed a light meter with the widest bandwidth possible. But high sensitivity was equally desirable. These two parameters result in an inevitable trade-off.

In the event, a medium-area silicon photocell was chosen. It was operated with zero reverse bias to achieve a low dark current and good noise figure, at the expense of sensitivity.

The final circuit, Fig. 1, offers a wide range of sensitivities, sensitivity on range 1 being a hundred thousand times that on range 6. The photocell used was an 'unfiltered' example of the SMP600G-EJ, i.e. one fitted with a clear window.⁴ This is a silicon diode with an area of 4 by 4mm overall, an effective active area of 14.74mm² and a capacitance at zero volts reverse bias of 190pF. A similar alternative is RS 194-076.

Responsivity as a function of wavelength is as shown by the unfiltered curve in Fig. 2. The diode connects to the virtual earth of an op-amp. This op-amp is used as a transimpedance amplifier; that is to say, the photodiode output current is balanced by the current through the feedback resistor, giving a volts-out per microamp-in determined by the value of R_f.

The op-amp selected might seem an unusual choice, but it offers very wideband operation. It has a very low value of input bias current of 2pA typical, although at

20nV/√Hz, its input noise is not as low as some other op-amps. Especially bearing in mind that the noise is specified at 1MHz; the 1/f voltage noise corner frequency and the current noise are not specified on the data.

The TSH31 has a slew rate of 300V/μs and a gain bandwidth product of 280MHz. In addition, it has a modest gain of typically 800 under open-loop conditions. This means that for the higher values of feedback resistor in Fig. 1, all of the loop gain is safely rolled off by the CR consisting of R_f and the capacitance of the diode, before the loop phase shift reaches 180°.

Even on range 6, where R_f is 100Ω, the circuit is stable - at least with the diode connected. With it removed, the circuit oscillated gently at 160MHz, so there might be problems if one elected to use this op-amp with a small area diode, having a much lower capacitance.

On the other hand, where sensitivity to extremely low light levels is needed - the proverbial black cat in a cellar - the value of R_f can be raised to 100MΩ, 1000MΩ or whatever, as desired. But note that using a tee attenuator in the feedback path, to simulate the effect of a very high resistance with more modest values, will incur a severe noise penalty. It does this by raising the 'noise gain' of the circuit. Raising R_f provides more gain with no penalty of increased noise.

Careful construction is needed, with short leads around the op-amp and especially for the decoupling components. But for possible fur-

ther experimentation with different photodiodes, the diode was connected via a 180° five way DIN plug and socket. The board carrying the op-amp circuitry was mounted as close as possible to S₁ and the DIN socket.

The photodiode was mounted in the back-shell of the DIN plug which, being of the better variety with a retaining latch, had a shell of solid metal construction. I removed the rubber cable support sleeve, and reamed the hole out to accept the metal can (a two-lead, half-height TO39 style) of the photodiode.

One lead is connected to the diode cathode and also to the can, so naturally this lead was earthed. When the diode is illuminated, the anode tries to go positive, and thus sources current which is sunk by the short circuit provided by the op-amp virtual earth. Thus, due to the inverting configuration, the output signal is negative-going.

A small mains transformer with a single 7.5V secondary winding was used to power the instrument, the op-amp being supplied via 78L05 and 79L05 ±5V regulators. In addition to providing a sample of the op-amp output voltage for monitoring on an oscilloscope, a 1mA full-scale meter was provided. This reads the average value of the photodiode output at frequencies where the inertia of the movement provides sufficient smoothing - i.e. from a few hertz upwards.

Prototype testing having been satisfactory, I constructed the final version in a small sloping panel instrument case, RS style 508-201. The

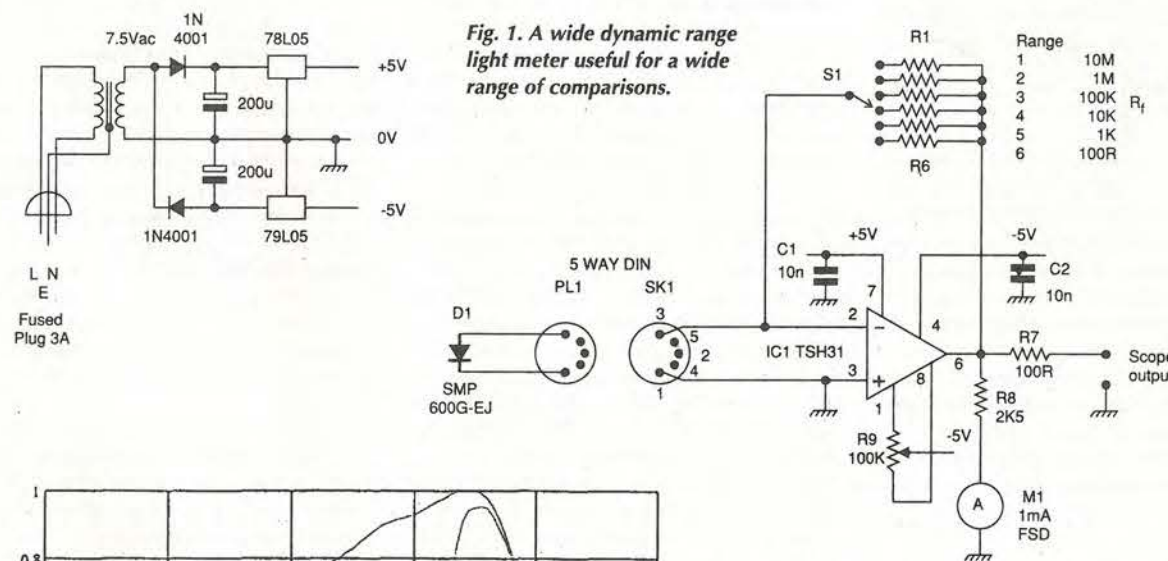

Fig. 1. A wide dynamic range light meter useful for a wide range of comparisons.

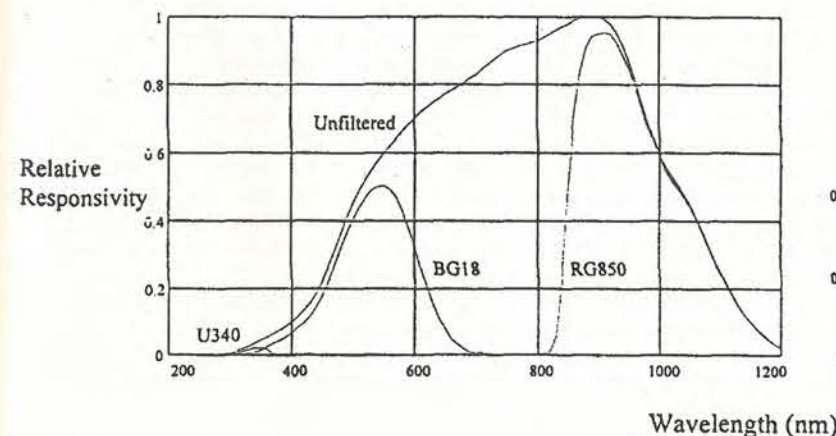
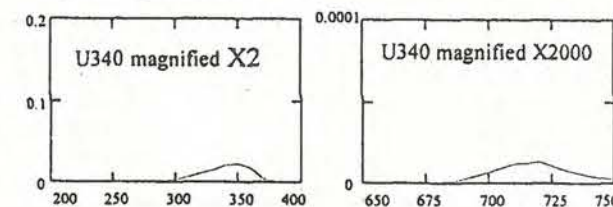

Fig. 2. Responsivity as a function of wavelength of the photodiode used in Fig. 1.



DIN socket was mounted at the centre back, S_1 top rear, the meter on the sloping panel and the mains transformer as far forward as possible.

Provision was made for fitting a screen between the transformer plus power supplies

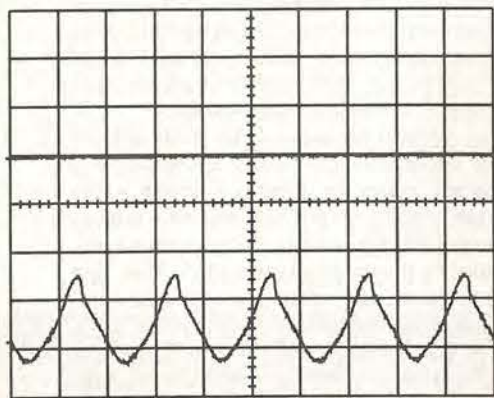

Fig. 3. Variation of light output from a 'white' fluorescent lamp. Photodiode at 50cm from the tube, lightmeter set to range 3. Oscilloscope settings 5ms/div. horizontal, 0.2V/div. vertical, 0V at centre line.

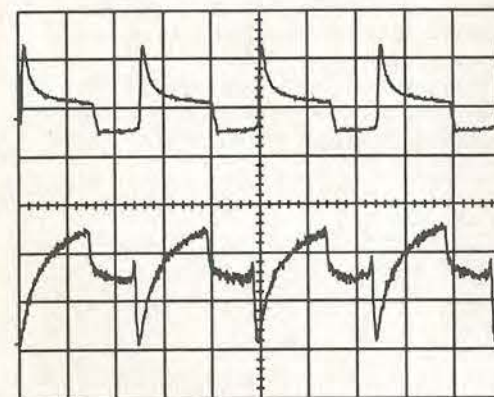

Fig. 4. Variation of light output from an uncoated fluorescent lamp. Photodiode at 30cm from the tube, lightmeter set to range 3. Lower trace: light output as measured by circuit of Fig. 1, 5ms/div. horizontal, 0.2V/div. vertical, 0V at centre line. Upper trace: waveform of the voltage applied across the tube, via capacitive pick-up, 5ms/div. horizontal, 2V/div. vertical, 0V at two divisions above centreline.

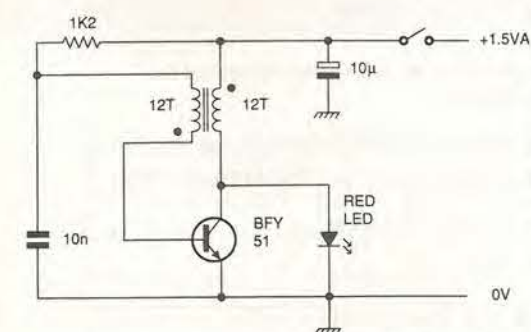

Fig. 5. Circuit diagram of a pocket torch using a 3000mcd red led.

board at the front, and the op-amp circuitry at the rear, but in the event this proved unnecessary. Even on the most sensitive range there was no visible hum pickup amongst the general background noise, which amounted to some 20mV peak to peak on range 1, the most sensitive range.

Measures leds, but what-else?

Before measuring any leds, I used the instrument to check two other sources of light, one of them the fluorescent light over my bench.

I believe that high-frequency ballasts are more efficient than conventional ballast chokes because the gas plasma does not have a chance to recombine between successive pulses of current in a high-frequency choke.

In a fluorescent fitting with a conventional ballast inductor, part of the energy in the 100Hz current pulses is spent re-establishing the plasma on each cycle. But recombination is not entirely complete between pulses; if it were, then the starter would need to produce a high-voltage kick every half cycle.

It was interesting to see the actual variation of light output over a mains cycle, shown in Fig. 3. This waveform was recorded on range 3 of the lightmeter, with the photodiode head at 50cm from the tube, a Thorn 2ft 40W 'white 3500' type - presumably with a colour temperature of 3500°. Given the 5ms/division timebase setting, the intensity variations are seen to be, as expected, at 100/s.

Characteristics of a silicon photodiode, used in voltage, i.e. open-circuit, mode are non linear and independent of the diode area. But in current, or short-circuit, mode, the sensitivity is proportional to the effective area of the diode, and extremely linear versus incident light intensity. It remains linear over eight or more orders of magnitude, from a lower limit set by the noise-equivalent power upwards.

The zero current line in Fig. 3, corresponding to complete darkness, is indicated by the trace at one division above the centre line. So Fig. 3 shows that between peaks at 4.25 divisions below the zero line, the light output falls to just under 60% at 2.5 divisions below.

There certainly seems to be evidence of a sudden increase of light just after the start of each half cycle of voltage, following the dip. And of course, being ac, the tube current must go through zero twice every cycle.

How brightly the plasma glows at that instant is a moot point, since the light output is mainly due to the tube phosphors of assorted colours, to give a whitish light. If the phosphors used have different afterglow times, there will be variations in 'colour temperature', as well as light output, over the course of each half cycle - just to make things even more complicated.

So I next looked at the radiation from a fluorescent tube without any phosphor, which therefore produced a bluish light. Being entirely without any safety filter, it also produced both soft and hard ultraviolet radiation. It was a 12in tube type G8T5, used in an electronic ballast powered from 12V dc. This started life as a camping light, but the original

tube was removed and the ultraviolet tube fitted when it was converted into a homemade eprom eraser.

The unit was fitted into a long box, the front being closed by a removable, long, L shaped eprom carrier. This was to avoid external radiation when in use, as hard ultraviolet light is bad for the eyes.

With the carrier removed and the photodiode at a distance of 30cm from the tube, the light output measured on range 3 is indicated by the lower trace in Fig. 4. The 30cm separation was more than sufficient to ensure that there was no capacitive coupling between the high voltage waveform applied to the tube, and the photodiode element via the window. This is an important precaution, because the photodiode was not fitted with a mesh screen, available on other models.

The upper trace shows the waveform of the voltage applied across the tube. As measuring this voltage directly was inconvenient, it was recorded simply by placing the tip of an oscilloscope probe close to the end of the tube. The waveform at the other end was identical, but of course, the other way up.

The zero-voltage reference for the lower waveform is the graticule centre-line. It is clear that the light intensity closely follows the modulus of the voltage waveform, with just a little rounding. This rounding is not due to any limitations of the frequency response of the lightmeter. Presumably this means that the degree of ionisation in the plasma does not vary appreciably over the course of each cycle.

LEDs across the spectrum

It is clear from Fig. 4 that the electronic ballast ran at a frequency of about 20kHz - not so very different from a small pocket torch I made a few years back, when the first really bright leds appeared. It used a 3000mcd red led, powered from a single cell.

The circuit is as shown in Fig. 5. My records show that the circuit was built and tested as long ago as the end of 1990. It was constructed in one of those small transparent boxes used by semiconductor manufacturers to send out samples - very useful for all sorts of purposes.

Typical forward voltage of an led is between 1.5V and 3V, so some kind of inverter is necessary to run it from a single 1.5V cell. Figure 5 uses a blocking oscillator: the resistor provides base current to turn on the transistor and positive feedback causes it to bottom hard.

When the collector current reaches a value the base current can no longer support, the collector voltage starts to rise, and positive feedback causes the transistor to cut off abruptly. The collector voltage flies up above the supply rail, being clamped by the forward voltage of the led.

Energy stored in the inductor gives a pulse of current through the led, which was monitored by temporarily inserting a 1Ω resistor in its cathode ground return. The current peaked at 150mA and had fallen to a third or less of this value before the transistor turns on again.

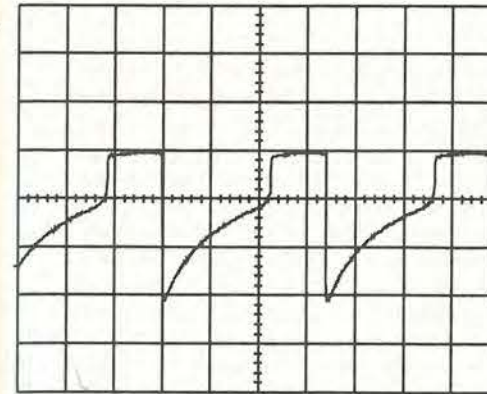

Fig. 6. Light output of the circuit of Fig. 5, measured using range 4 of the light meter, at a range of 1cm. 500mV/div. vertical, 0V reference line at one division above centreline, 10μs/div. horizontal.

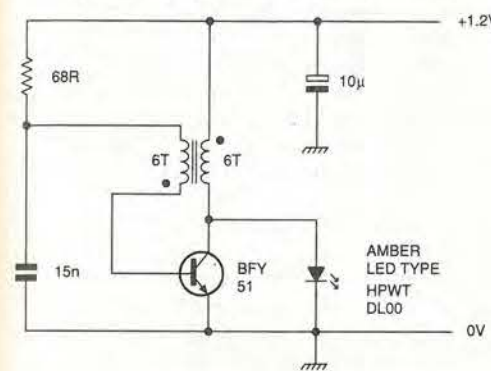

Fig. 7. Circuit of a pocket torch using an HPWT-DL00 amber led, designed to run from a single 1.2V NiCd cell.

The transformer consisted of a twelve turn collector winding of 0.34mm enamelled copper wire and a twelve-turn feedback winding of 40SWG enamelled copper, on an FX2754 two-hole balun core, which has an AL of 3500nH/turns squared.

You would not normally expect a 1:1 ratio for a blocking oscillator transformer, but special considerations prevail when designing for such a low supply voltage. Light output is shown in Fig. 6, measured using range 4 of

the light meter, at a range of 1cm.

Operating frequency - given the 10μs/division timebase setting - can be seen to be a shade under 30kHz. Although of course of a totally different colour, the red led torch seemed about as bright as one using a 1.2V 0.25A lens-end bulb, while drawing, by contrast, only 50mA. The circuit worked well also with the Panasonic blue led mentioned earlier.

I recently obtained some samples of very bright leds from Hewlett Packard Components Group, exemplifying the latest technology. The HLMP-D/Gxxx Sunpower series are T-1 3/4 (5mm) precision optical AlInGaP lamps in a choice of red, shades of orange, and amber.

These lamps are designed for traffic management, outdoor advertising and automotive applications, and provide a typical on axis brightness of 9300mcd. The HPWx-xx00 Super Flux leds are designed for car exterior lights, large-area displays and moving message panels, and backlighting.

An HLMP-DL08, with its half power viewing angle of ±4°, was compared with an HPWT-DL00 with a half power viewing angle of ±20°. At a spacing from the photodiode of 1cm on range 4, with 30mA in each diode, they gave similar readings, but at greater ranges, the reading from the HLMP-DL08 exceeded that from the HPWT-DL00, on account of its narrower beam.

However, the total light output from the HPWT-DL00 is greater, so it was chosen for an updated version of the led pocket torch of Fig. 5.

And brighter still...

The resulting circuit was as shown in Fig. 7, again using an FX2754 core. Due to its broad beam, the HPWT-DL00 produced a less bright spot on the opposite wall of the room than a two-cell torch with a 2.5V 300mA bulb. But this is only because the latter had the benefit of an extremely effective reflector, giving a very small spot size.

With the aid of a small deep curve 'bull's eye' lens from an old torch of the sort that used a No 8 battery, the torch of Fig. 7 more than held its own. It drew only 150 mA from

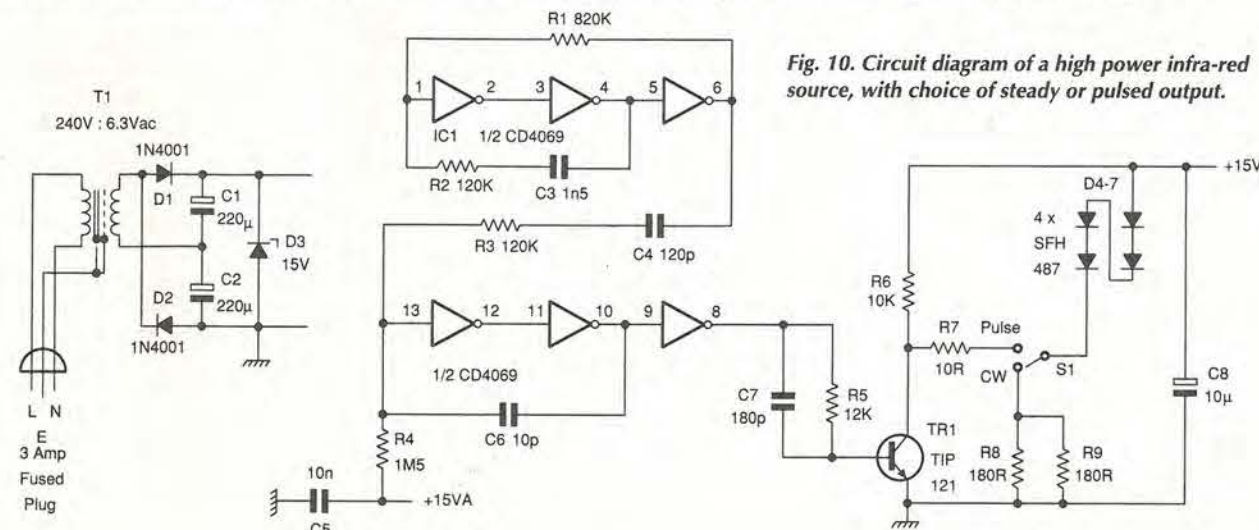

Fig. 10. Circuit diagram of a high power infra-red source, with choice of steady or pulsed output.

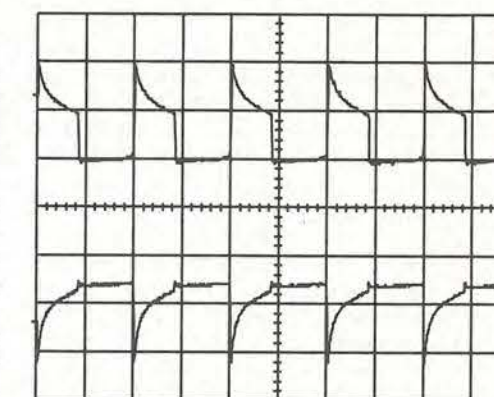

Fig. 8. Performance of the circuit of Fig. 7: a) collector waveform (upper trace), 2V/div. vertical, 0V line at one division above centreline, 10μs/div. horizontal. b) base waveform (lower trace), 2V/div. vertical, 0V line at two divisions below centreline, 10μs/div. horizontal.

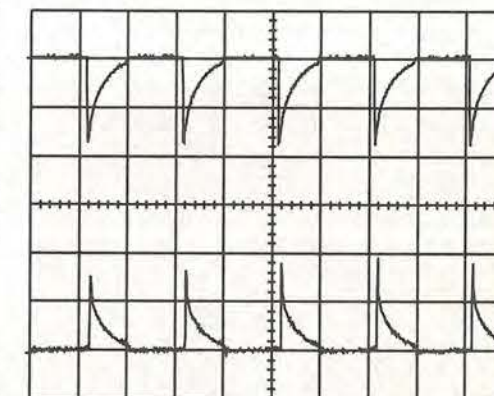

Fig. 9. Performance of the circuit of Fig. 7: a) light meter output (upper trace), 1V/div. vertical, 0V line at three divisions above centreline, 10μs/div. horizontal. b) diode current waveform monitored across a 0.18Ω resistor, lower trace, 50mV/div. vertical, 0V line at three divisions below centreline, 10μs/div. horizontal.

from a single cell. This makes it about four times as efficient as the torch bulb, with a colour rendering that is not so very different. It is certainly much more acceptable that the red led torch.

Figure 8 shows the performance of Fig. 7. The upper trace shows the collector voltage waveform at 2V/div. vertical, the 0V line being at one division above the centreline, and 10µs/div horizontal. On the lower trace is the base waveform at 2V/division vertical, 0V line at two divisions below centreline, 10µs/div horizontal, the operating frequency being about 50kHz.

Figure 9 shows the output of the light meter on range 4 at 1V/div. vertical, 0V line at three divisions above centreline, 10µs/div. horizontal. It is clear that the light pulse has almost completely extinguished by the time that the transistor turns on again to store more energy in the transformer primary. This is also seen in the diode current waveform, monitored across a 0.18Ω resistor. The lower trace is at 50mV/div. vertical, 0V line at three divisions below centreline and 10µs/div. horizontal.

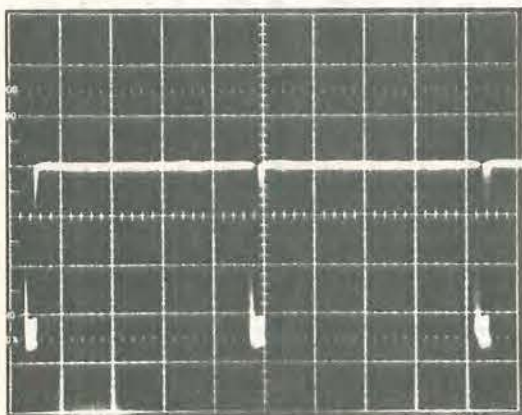

Fig. 11. Lightmeter output at a range of 2cm from the four diodes, on range 5. 1V/div. vertical, 0V reference at centre line, 10µs/div horizontal.

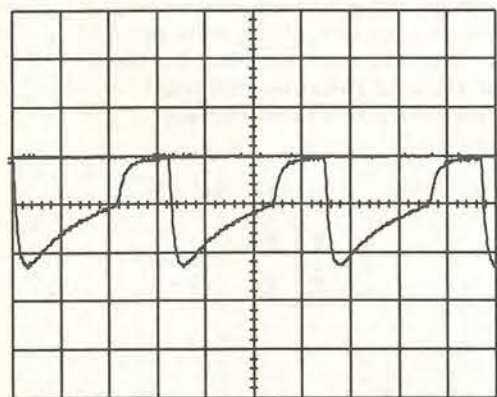

Fig. 12. Light output of the circuit of Fig. 5, measured using range 2 of the light meter, at an increased range. 500mV/div. vertical, 0V reference line at one division above centreline, 10µs/div. horizontal.

Peak diode current is just on 400mA. Although peak current for the HPWT-DL00 is not quoted on the data sheet, the average current is safely within the 70mA maximum allowable at 25°C.

The circuit again used a BFY50 transistor. It also worked with a BC108, although that device actually needed a lower value of base resistor. This was despite its small signal h_{FE} of 500, against the 130 of the BFY50 – which only goes shows that in a switching circuit, a switching transistor beats one designed for linear applications.

Very bright – but invisible

Figure 10 shows the circuit diagram of a little instrument I made up recently for a specific purpose, of which more later. It uses four Siemens infra-red leds, type SFH487.

The unit offers a choice between constant and pulsed illumination. The three-inverter oscillator runs at about 450Hz, and its output is differentiated by C_4 and R_4 . This 180µs time constant, allowing for the effect of R_3 and the internal protection diodes of the inverter input at pin 13 of the CD4069, results in a positive-going pulse of about 100µs duration at pin 8.

Having a string of three inverters speeds up the trailing positive edge of the pulse at pin 13. But with three inverters on their own, a glitch on the trailing edge of the pulse is inevitable, due to internal coupling between the six inverters in the package. So C_6 is added to provide a little positive feedback to make the trailing edge of the pulse snap off cleanly.

Figure 11 shows the output of the lightmeter when illuminated by the diodes, at a range of 2cm on range 5. Despite the presence of D_3 , there is still some 100Hz ripple on the supply line. This results in some 100Hz modulation of the pulse amplitude, and also of the pulse repetition frequency, or prf, both visible in Fig. 11.

To show this, I used a Polaroid photograph of the display on a real time analogue oscilloscope. My simple digital storage oscilloscope stores only a single trace per channel at a time; its facilities do not run to a variable persistence mode such as is found on the more expensive models.

Fortunately, for the intended purpose, the 100Hz modulation was unimportant. The predominant wavelength of the infra-red radiation from the diodes is 880nm, this being in the range favoured for physiotherapy purposes. Incidentally, although the spectral bandwidth is quoted as 80nm, the tail of the spectral distribution evidently extends some way – even just into the visible part of the spectrum – as in operation the diodes exhibit a very faint red glow.

Switch S_1 allows the four infra-red diodes to be powered by dc, or via Tr_1 , with the pulses. Given their aggregate forward voltage of about 5V, the current through the diodes on cw, determined by $R_{8,9}$ and supply voltage, is

the rated maximum for the devices of 100mA.

In pulse mode, the peak current reaches the rated peak maximum of 1A. But the duty cycle of around 5% keeps the average current to just half of the steady state dc maximum.

The circuit is supplied from an old 6.3V transformer which was probably intended originally as a tv spare. It would have been used to power the heater of a crt which had developed a heater/cathode short, thus extending its life and avoiding a costly replacement. This would explain the inclusion of an interwinding screen in such a small, cheap transformer.

In the cw position of S_1 , the supply voltage is a shade under 15V, but tended to rise to nearer 17V with the lower average current drain in the pulse mode. So I added D_3 to give the designed nominal supply voltage value of 15V on pulses also.

Resistor R_6 serves to pull the collector of Tr_1 up to +15V between pulses. Without it, the voltage lingers at about +10.5V, since with much less than 5V across the string of diodes, they become effectively open circuit.

Limitations of the lightmeter

Useful as the lightmeter has proved, it is necessary to bear in mind its limitations. One of these is the sensitivity/bandwidth trade-off mentioned earlier.

To illustrate this, Fig. 12 shows the same waveform as Fig. 6, the output of the red led torch of Fig. 5. But whereas Fig. 6 was recorded with the lightmeter set to range 4, for Fig. 12, the light reaching the photodiode was greatly reduced. In addition, range 2 – which is a hundred times more sensitive – was used.

The reduced bandwidth is clearly evidenced by the rounding of the edges of the waveform. With the incident light lowered yet further and range 1 selected, the waveform was reduced almost to a triangular wave. But while waveform high frequency detail was lost, note that the average value of the incident light is still accurately recorded.

The other great limitation of the lightmeter is, of course, that it provides no absolute measurements. To do so, it would have had to be calibrated with a standard light source, and none was available. Even then, absolute measurements would be difficult, as they always are in photometry. This especially true when comparing 'white' light sources of different colour temperatures, and even more so with leds where about 90% of the output radiation is within ±5% or less of the predominant wavelength.

Nevertheless, the instrument is exceedingly useful for comparisons, and for studying the variations of light output of a source as a function of time.

It can be made even more useful by incorporating a filtered diode. Using a diode with the U340 filter, see Fig. 2, the blue led tested earlier even produced zero response on range 1. Its predominant wavelength λ is 450nm.

The spread delta λ is quoted as 70nm, although the data sheet does not say whether this represents the 50%, 10% or 1% power bandwidth. But evidently there is no significant tail to the distribution extending as far into the ultra-violet at 375nm, where the U340 filter cuts off. The ultra-violet filtered diode did show a small output when held close to a 60W bulb. This was due to the very small filter response shown in Fig. 2, in the region of 720nm.

Medical applications

Clearly, one should be very wary of experimenting in this area*. Some medical applications of optoelectronics are spectacular and hence deservedly well known, such as the use of laser radiation to stitch a detached retina back in place. Other uses are less well known, but one, the use of infra-red radiation in physiotherapy I have personal experience of.

It was used, with great success some years ago, to treat supraspinatus tendonitis, alias a painful right shoulder. At the time, an infra-red laser with just 5mW output was used, although since then equipments with 50mW output have become available.

The low dispersion offered by a laser source,

means that the energy can be applied with pinpoint accuracy to the affected spot, which is very useful when the power available is low. But I was advised by a physiotherapist (with a degree in physics and an interest in electronics) that apart from this, there is no reason to suppose that an infra-red laser has any specific advantage over any other source of infra-red.

Having recently experienced a return of the tendonitis, I designed the unit of Fig. 10 to treat it. Despite my earlier warning about experimenting, this seemed a safe enough procedure, given that both the condition, and the treatment had been previously properly diagnosed.

At 100mA forward current, the four diodes provide a total radiant flux of 25mW each. They were mounted as close together as possible on a scrap of 0.1in pitch copper-strip board, each angled slightly in so that their beam axes crossed at about 1cm out. It is thus possible to flood the affected area with infra-red radiation, where, the theory goes, it 'energises the mitochondria', the chemical power house of each cell, promoting healing.

I am happy to report a marked improvement, following a few five minute sessions on

alternate days. The pulse mode was incorporated to allow for the possibility that the effect is nonlinear with respect to intensity.

Instead of half the radiation producing half the effect, and a quarter just a quarter, it might be that half the radiation intensity produced only a tenth of the effect, and a quarter none at all. But the interim conclusion of my limited experience suggests that there is little difference between the efficacy of the pulse and cw modes.

*Ian's medical experiments have been reported purely for interest. We do not advocate that you try such experiments yourself. Medical experiments should be carried out only with medical supervision – Ed.

References

- Hickman, I, 'Sensing the position', *EW+WW*, Nov. 1992, pp 955-957.
- Hickman, I, 'Reflections on optoelectronics', *EW+WW*, Nov. 1995, pp 970-974.
- Robinson, D, (TI), 'Light update', *Electronics World*, Sept 1996, pp 675-679.
- Semelab plc, Coventry Road, Lutterworth, Leicestershire LE17 4JB. Tel. 01455 556565, Fax. 01455 552612.

20MHz Kenwood oscilloscope – £100 saving

Featuring circuitry that synchronises the displayed waveform automatically – removing the need for complex sync adjustments – the dual-channel CS4125 20MHz oscilloscope represented excellent value for money at its retail price of £410 including VAT but excluding delivery.

For a limited period, Vann Draper is offering readers this instrument at the special discount price of £319 – including VAT and delivery – representing a saving to you of over £100.

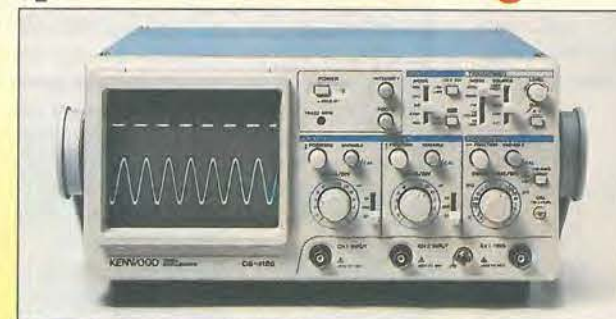

Includes x1, x10 probes

Outline specifications

Vertical amplifier	
Sensitivity	5mV to 5V/div, ±3%, 1 to 2mV/div ±5%
Attenuator	1-2-5 steps, 12 ranges, fine adjustment
Frequency response	5mV to 5V/div DC-20 MHz -3 dB or 10 Hz to 20 MHz -3 dB on AC range 1mV to 2mV/div DC-5 MHz -3 dB or 10 Hz to 5 MHz -3 dB on AC range
Crosstalk	-40 dB
Operating modes	CH1: CH1 single-trace CH2: CH2 single-trace ALT: alternate CH1 and CH2 display CHOP: chopping display of CH1 and CH2 ADD: Combined waveform of CH1 and CH2
Horizontal amplifier	
Sensitivity	same as vertical axis (CH2)
Response	DC: DC to 500kHz -3dB AC: 10Hz to 500kHz -3 dB X-Y phase matching within 3° at 50kHz
Operating modes	CH1: Y axis, CH2: X axis
Sweep	
Modes	NORM: trigger sweep AUTO: auto free-running with no signal
Sweep time	0.5 µs to 0.5s/div ±3% (0.2µs/div uncal.), 1-2-5 steps, 20 ranges w. fine adjustment
Sweep magnify	x10 ±5% (20ns/div uncal.)
Triggering	
Trigger sources	VERT MODE: input signal selected in VERTICAL mode CH1: CH1 input signal CH2: CH2 input signal LINE: commercial power supply EXT: EXT. TRIG input signal
External triggering	
Input impedance	1MΩ and 22 pF approx.
Coupling modes	AUTO, NORM, FIX: AC coupling TV-FRAME: TV-LINE
Calibration o/p	
Intensity mod.	square wave, positive polarity, 1Vp-p ±3%, approx. 1kHz TTL input to 3.5 MHz and CH1 o/p 50mV/div to 10MHz

Use this coupon to order your CS4125

Please send me CS4125 20MHz oscilloscope(s) at the fully inclusive special offer price of £319.

Name _____

Company (if any) _____

Address _____

Phone number/fax _____

Total amount £.....

Make cheques payable to Vann Draper Electronics Ltd

Or, please debit my Master, Visa or Access card:

Card type – Access Visa

Card No _____ Expiry date ____/____/____

Please mail this coupon to Vann Draper Electronics, together with payment. Alternatively fax credit card details with order on 0116 2773945 or telephone on 0116 2771400. Address orders and all correspondence relating to this order to Vann Draper Electronics at Unit 5, Premier Works, Canal Street, South Wigston, Leicester LE18 2PL.

*Overseas readers can also obtain this discount but details vary according to country. Please ring, write or fax to Vann Draper Electronics.

Hands-on Internet

Cyril Bateman looks at new search options, a directory for finding UK electronics companies and filter design tools.

The continuing escalation of Web pages available on Internet has resulted in very heavy loading and consequent delayed responses, for the most popular all-purpose search engines. This has resulted in two major improvements – the location of mirror sites outside North America for these all-purpose search engines, and the development of search engines targeted only to specific tasks.

In the March issue I highlighted the version of 'YahooUK', dedicated to searching Internet for UK and Irish surfers. This month's 'bookmark' site, Altavista.telia.com¹ has introduced local search engines available for most countries and languages, which truly complements the parent site. While the full address is quite long, bookmarking it makes for extremely easy access.

Previously, telephone and fax numbers for North America were easily accessed using Internet, but not so for other countries. Applegate Media² has now released its Web site which specifically aims to supply the telephone and fax numbers of the UK electronics industry. Since this is a lengthy listing it is best accessed during a quiet period, and downloaded to your hard disk for easy future reference.

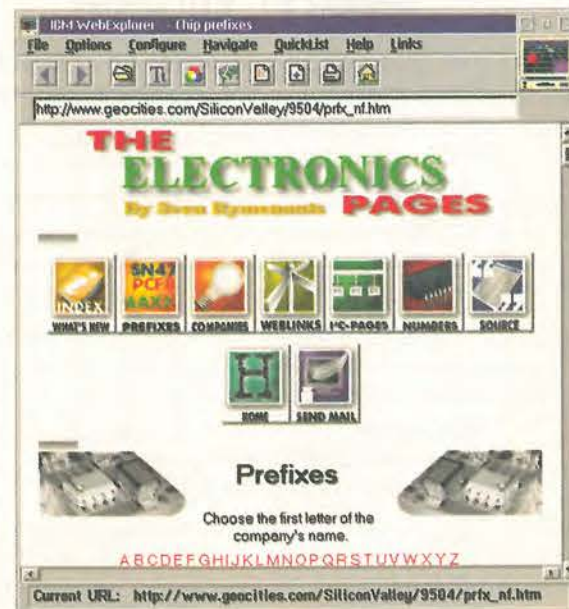

Fig. 1. Easy identification of Internet addresses for Semiconductor Companies. Find direct links to home or data-sheet pages.

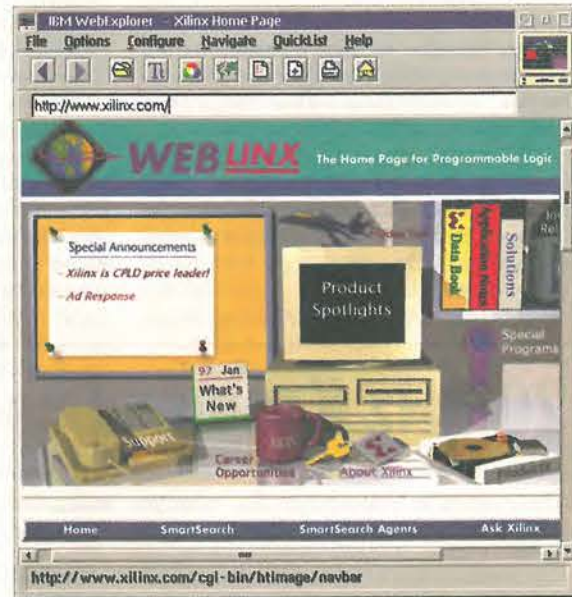

Fig. 2. In my view, the best selection of programmable logic data information available on the Net. Register here to set up your desired smartsearch agent.

Fig. 3. Home of the surface-mount technology reference centre contains directories of surface-mount equipment and component suppliers.



You can often guess the Internet address of a company by simply using its name, plus '.com'. When this fails, in the past I have found a search on Altavista able to supply the needed address. However for Web addresses of semiconductor makers, the best method now is to use Electronics Pages³. This not only supplies the addresses, it also provides direct web links to either the required home or data sheet pages. While the initial download is lengthy, once retained in your browser's temporary disk files, repeat access is extremely quick, beating all other methods, Fig. 1.

Still in development, EDAMall⁴ a new site, is based on an electronic shopping 'mall' which allows you to try, using real-time demonstrations, or buy, using a credit card, several electronic design automation systems. With its large reference library of technical articles and industry news, surfing this site can dramatically reduce the time needed to find essential pre-purchase information.

This site requires use of 'Java', 'Javascript' and a 'Java' enabled Netscape browser for full access. Three subsidiary malls cater for mechanical cad, scientific cad and software development.

When looking for programmable logic data, try Xilinx.com⁵ This site has its own specialised Weblinx smart-search method which looks for information within the fifty best PLD sites as well as Xilinx itself. Regular users can define their own smartsearch 'agent' which automatically informs them via e-mail of any updates or new documents within the parameters they specified, Fig. 2.

Almost all new electronic designs use surface mounted parts, so SMTnet⁶ is an essential stopping off place to browse for a few minutes. Particularly useful are the industry directories of surface mount equipment makers and surface mount component suppliers. This last is searchable either by product or manufacturer's name. Alternatively an alphabetical list of all component suppliers can be generated, Fig. 3.

Many established technical libraries of data, or software models, are located at sites which can only be accessed using Telnet. While a web browser can link you to a Telnet site, once connected one cannot access the site using a browser and must continue by using a Telnet client, its protocols and typewritten commands.

While having a dedicated Telnet client in my computer, I must confess to using it with some reluctance for one-off site visits. For regular access to a particular site, having learned that site's command set, Telnet is a very good access method indeed, but unlike Web pages, Telnet certainly is not a point and click method.

Perhaps this is about to change. TechOnline,⁷ formerly known as DSPnet, has been updated by Alphas to become a truly interactive engineering forum. It is based on use of a Java applet which allows your browser to emulate a Telnet terminal within a Web page. This applet loads and executes dsp and other demonstrations automatically, using the site's so-called virtual laboratory. In this way, data searching is neatly combined with dsp simulations, Fig. 4.

Software simulated and Fairchild reborn

A return visit to National⁸ to download up to date details of state variable filter chips together with listings of relevant application notes, revealed a late news item. Fairchild Semiconductor, comprising the old logic, memory and discrete lines of National, was relaunched in January as a separately funded subsidiary. For further details see the new Fairchild⁹ home page, Fig. 5.

Effective active filter circuits can be built using either switched-capacitor or time-continuous techniques. For many low-noise, wide dynamic range or high-frequency design needs, the time-continuous filter is essential. Given the appropriate macromodels, the circuits can be simulated using a version of Spice. However, this design task is especially

suited to the use of simple but dedicated filter design software.

Burr-Brown¹⁰ offers similar time-continuous filter products and design software. This company too had a news announcement. The Burr-Brown home page has been given a new look and extra functions by way of celebrating the first anniversary of their publishing a Web page. While Spice



Fig. 4. Virtual dsp test laboratories on-line are provided by the home of dsp. Using a unique Java applet it links the Web browser with Telnet.

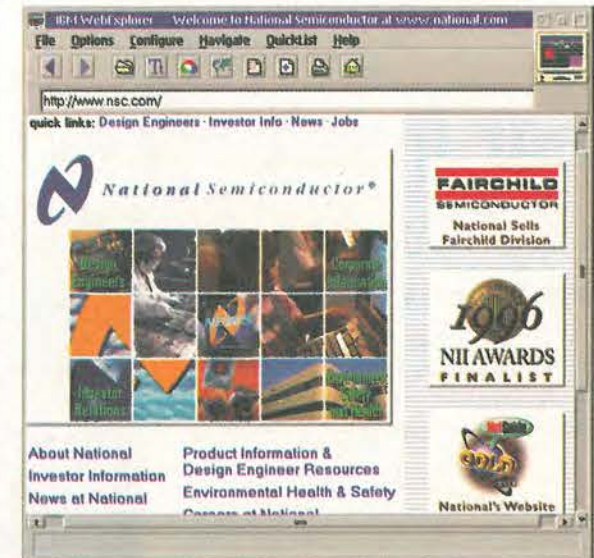

Fig. 5. National announces Fairchild spin-off. Visit to download your filter application notes in PDF format.

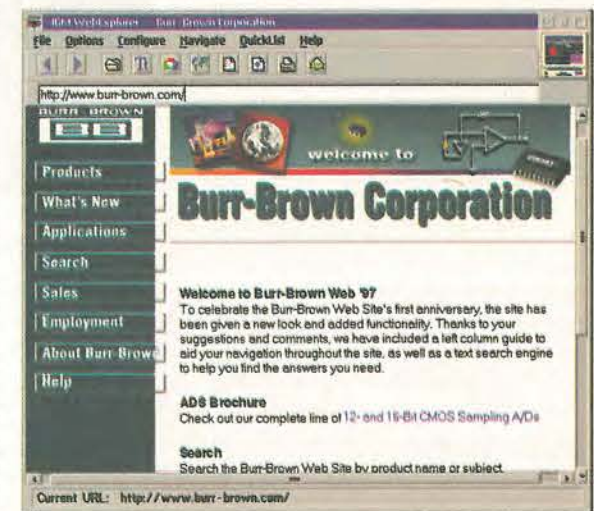

Fig. 6. Burr-Brown's Web anniversary celebration homepage. Download Filterpro software and application notes on-line.

Error feedback in audio power

In response to a plea for help on a feedback problem, William de Bruyn has unearthed three alternative methods of error feedback for power amplifiers that do work.

Following K H Ellis's plea for help in 'Feedback on Feedback' in the December 1996 issue, it seems to me that his amplifier (outlined later) was always bound to be unstable. Little or no attention seems to have been given to issues of loop stability.

Addition of the 22pF capacitor simply inserts a dominant pole at a suitable frequency; it does not 'filter' noise. The operational amplifier chosen for this implementation of Hawksford's error-cancelling idea is not particularly suitable as the inherent slew rate limitations of the device restrict the potential bandwidth.

There has been a number of practical amplifier designs which have used the idea of an error feedback loop around the output stage of an amplifier.

First is a design by E. M. Cherry, which deals with a number of issues rather elegantly. Quiescent current is sensed and controlled without any need for complex schemes of thermal feedback. Such schemes bring with them the difficulties of dealing with all of the ther-

mal/electrical time constants.

Prof. Cherry's approach to this problem – the feedback loop around the back-to-back differential pairs – also permits accurate setting of the gain of the output stage to some desired level.

His concept of nested differentiating feedback loops achieves unconditional stability with high levels of feedback and very low distortion within the audio band.

A further amplifier of note is designed by Robert Cordell. It was published in 1983 and reprinted in the *Journal of the Audio Engineering Society*, Vol. 32, No 1/2, 1984, Jan/Feb.

This amplifier employs a simple method of feed-forward error correction based on Hawksford's scheme. The error-correction loop uses only two fast small signal transistors and the resulting improvement in transfer linearity is quite remarkable. Most of the crossover and transfer artefacts, that so much recent correspondence has concerned itself

with, become relatively minor issues.

This design is capable of extremely low distortion over a very wide frequency band – less than 0.001% from 20Hz-20kHz. It also exhibits extraordinarily good high-frequency and transient performance and achieves a slew rate of more than 300V/μs.

The third amplifier is a commercially produced design, namely the Tandberg 3009A. This also uses a variant of Hawksford's scheme. In this case no overall feedback is applied, each stage relying on local feedback for setting of overall gain. In this instance, the output stage used Hitachi mosfets. These fet's are distinguished from Hexfet structures by their substantially lower transconductance and threshold voltages. This Amplifier is capable of good high-frequency performance.

All in all, I feel that much of the rather heated debate regarding the linearity of igt devices as opposed to mosfets, 'batwing' transfer curves, etc. is rather absurd and has more to do with what people grasp with their hands

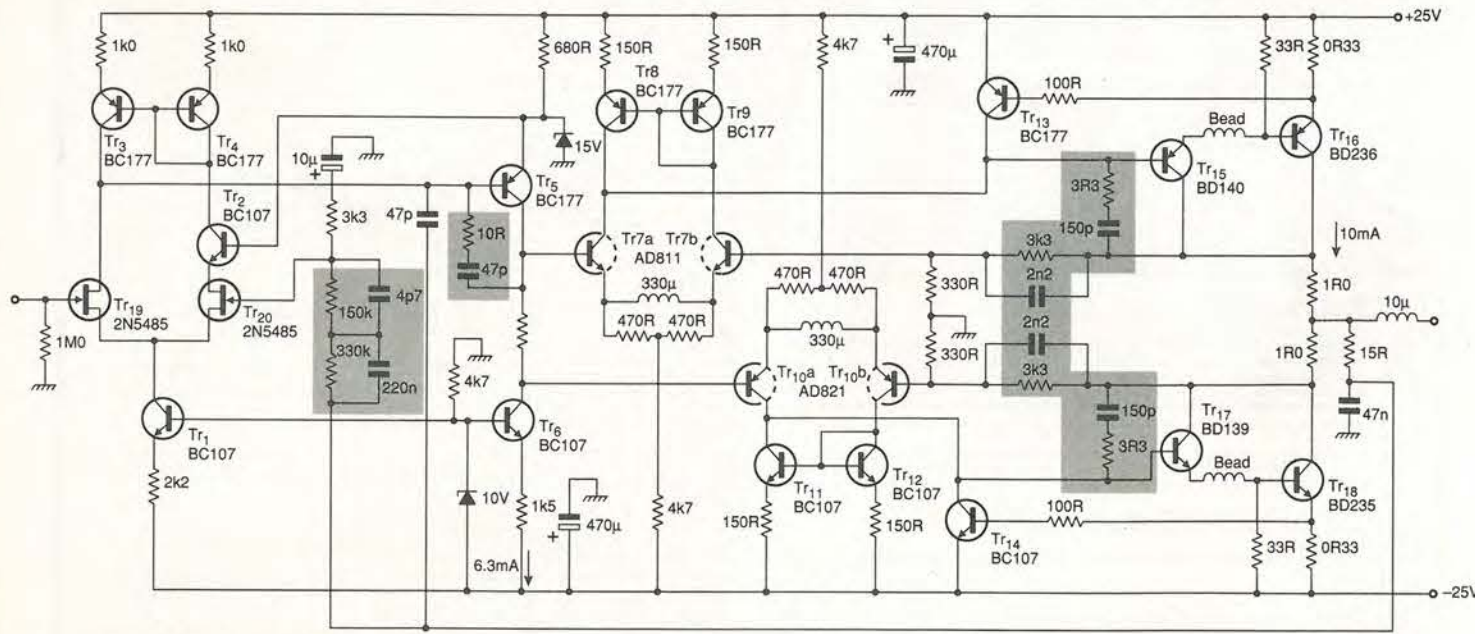
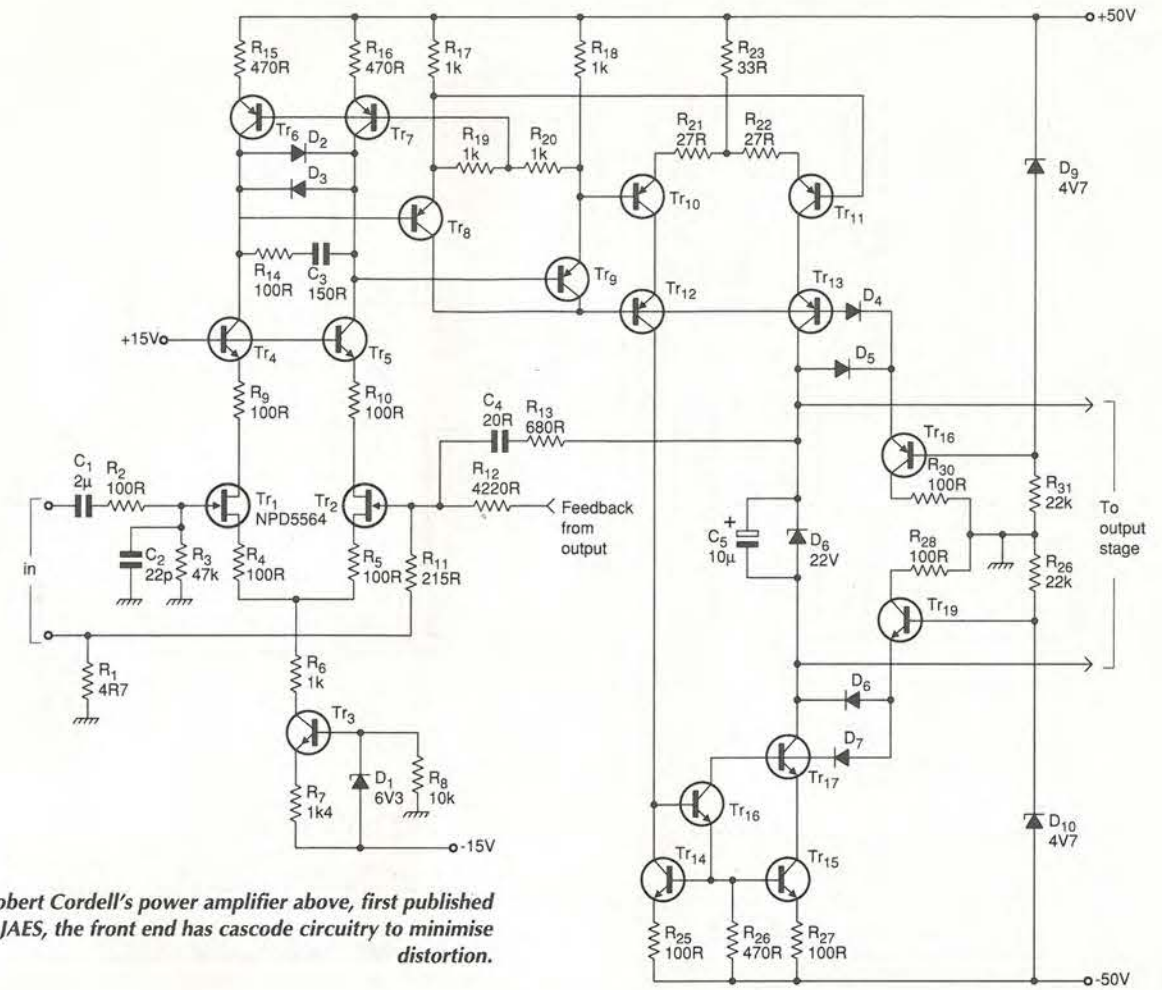
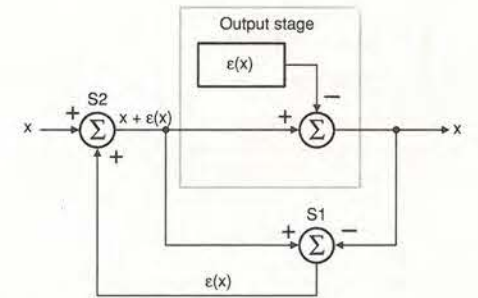
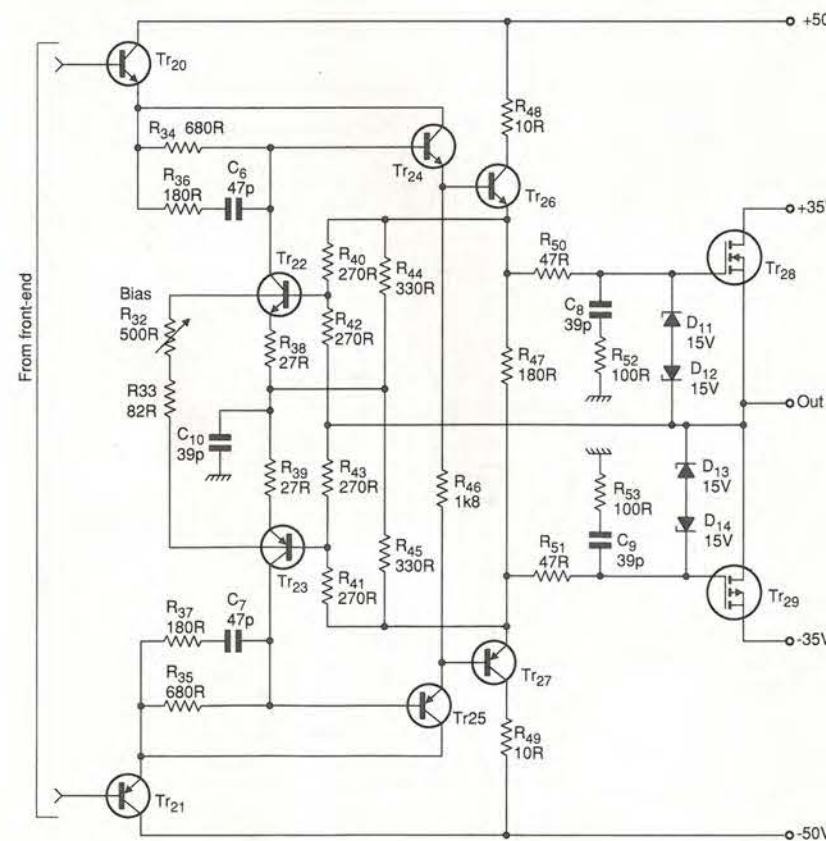

Fig. 1. Ed Cherry's 15W, 15Ω power amplifier, first published in IREE transactions, nested differentiating feedback loops are used. Note the driver circuit with inherent quiescent current regulation and substantial local feedback around the output stage.



In Robert Cordell's power amplifier above, first published in JAES, the front end has cascode circuitry to minimise distortion.



Error correction concept, above, for Cordell's power amplifier output stage, left, in which Tr22 and Tr23 provide the error correction.

rather than with their minds.

As many of the problems associated with amplifier design seem to centre on achieving ever greater bandwidth, it seems – to me at least – that the fastest available devices are the preferred option.

Poor transfer linearity can be readily dealt with by applying some sort of error correction around the output stage, without the problems of dealing with all of the poles that the application of overall feedback has to contend with.

I would be pleased to see someone apply some form of error cancelling feedback loop around, say, a valve amplifier output stage. Such devices are inherently less linear than mosfets and have much lower transconductance than any solid state device.

AUDIO

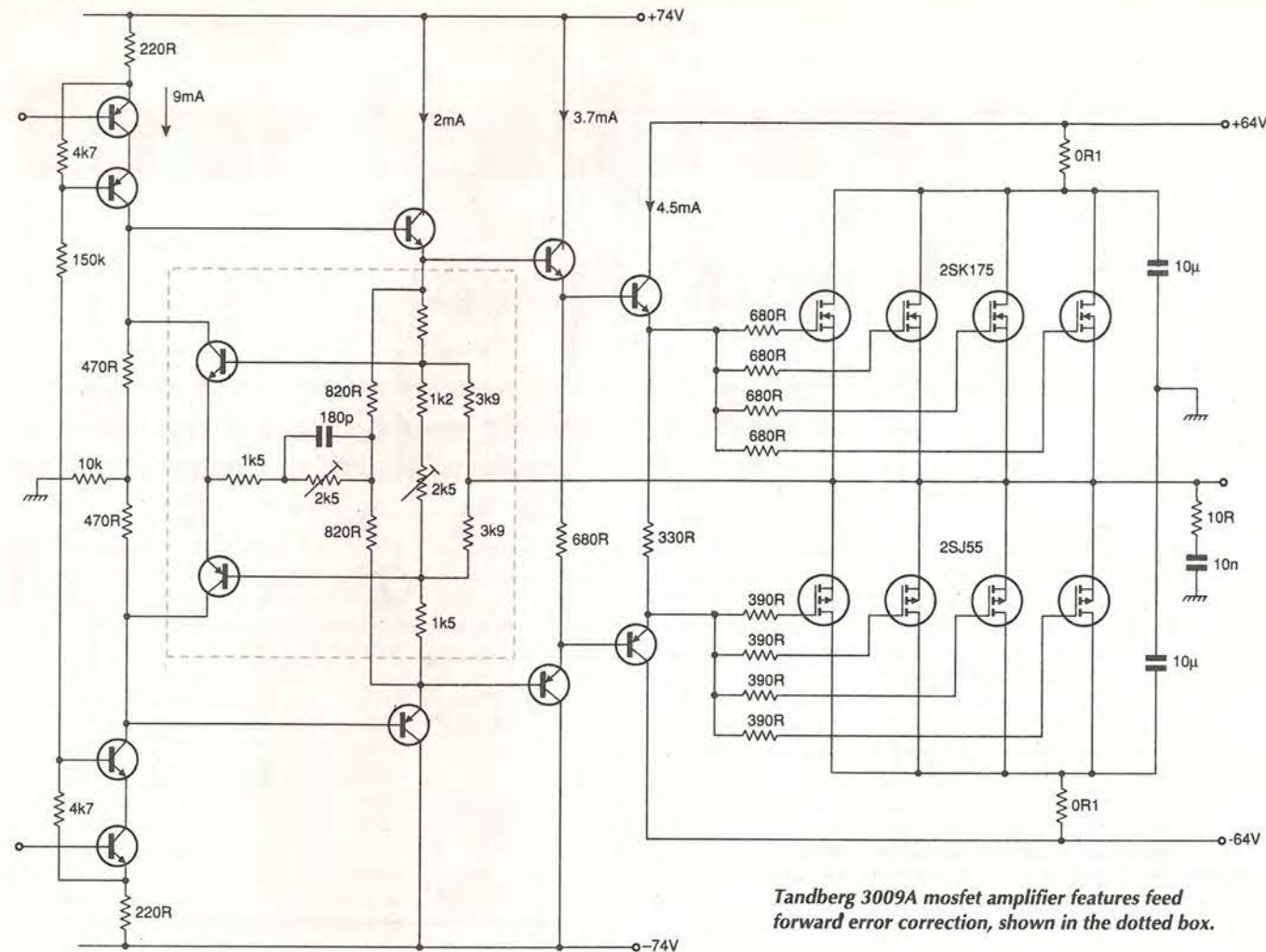

Tandberg 3009A mosfet amplifier features feed forward error correction, shown in the dotted box.

Extract from Ellis's original query

...applying negative feedback to give a gain of four, the stage shown gives reasonable performance, except that output impedance is about 1Ω. Also, when loaded, the stage distorts because there is nothing to increase the drive.

I was about to give in when I came across a reference to an error cancelling technique by Hawksford. The small diagram below gives the theory. Having got the gains right, the results were astounding.

During testing, I found that a capacitive load of more than 22nF caused a high output at high frequency. This was a surprise as the output stage itself would happily drive a 10μF at 1kHz. More experimenting gave the feeling that this was not parasitic oscillation, but rather amplified and filtered noise. While loading the output with increasing values of capacitor, the output of A₁ became increasingly noisy until it burst into oscillation at about 2MHz. Putting a small capacitor across R₈ (A₁) stopped the oscillation but was not the best place as only the error signal was being filtered. The best solution was a 22pF across R₁₂ (A₂) to filter signal and error. The amplifier now drives 10μF with no problem.

I would welcome your comments.

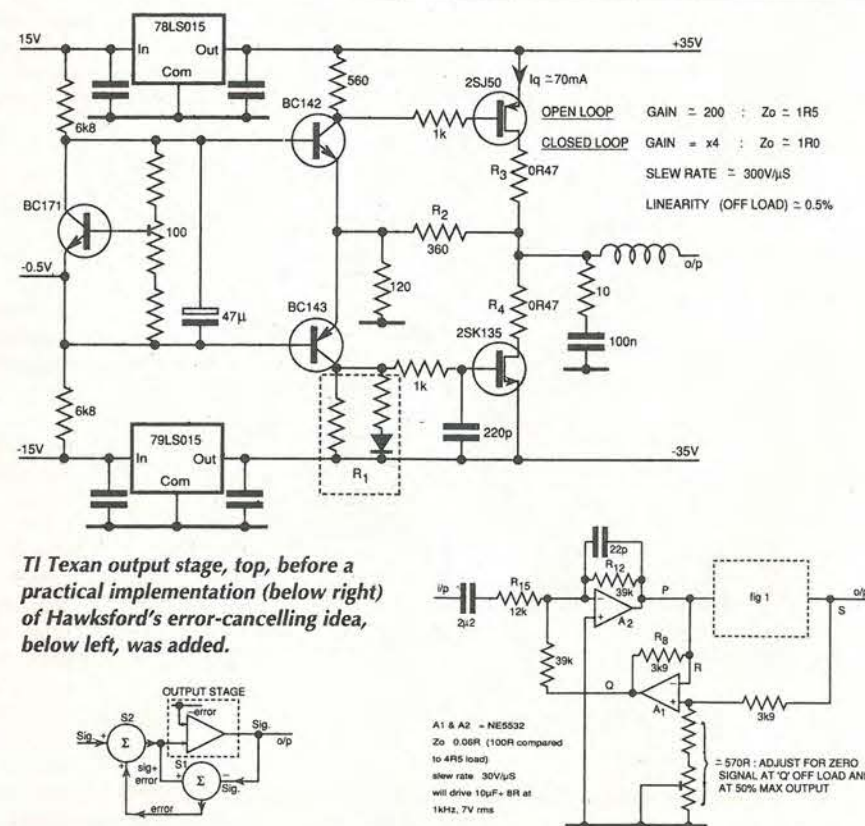

TI Texan output stage, top, before a practical implementation (below right) of Hawksford's error-cancelling idea, below left, was added.

Leading Edge Technology Ltd

Low cost Programmers for all your requirements

GAL PROGRAMMER £79.95

- 16V8 / 16V8A / 16V8Z, 20V8 / 20V8A / 20V8Z.
- Stylish compact case with quality ZIF socket
- Easy to use software - load/save in JEDEC format
- Plugs into Centronics printer port
- Works on any IBM PC or compatible / laptops / notebooks etc
- Fast and reliable programming using manufacturers algorithms
- Program protection fuses to prevent unauthorised copying
- Supplied with PLAN Logic compiler software
- Complete system with example files, connection lead, and PSU
- Full 12 months parts and labour guarantee



P87C51/2 PROGRAMMER £79.95

Programs all makes of P87C51/2 and Atmel 89C51 Flash types.

As above this unit plugs into Centronics printer port on any IBM PC or compatibles and comes complete with software, connection lead, PSU, and full 12 months guarantee.

MEGAPROM UNIVERSAL EPROM PROGRAMMER

EPROMS / EEPROMS / FLASH EEPROMS / I2C BUS EEPROMS

- Covers all types of Eprom, EEPROM, and flash up to 32 pin
- Fast programming and verification
- Easy to use software - supports Bin / Intel Hex / Motorola S and ASC file formats
- Read / Edit / Verify / reprogram etc
- Supplied with full 12 months parts and labour guarantee



Megaprom runs on any IBM PC / compatible, connects directly to the centronics printer cable and requires 12-18V AC/DC PSU. Low cost makes it ideal for hobbyists and engineers alike. £99.95

ENHANCED PIC PROGRAMMER

- Programs PIC54, 55, 57, 58A, 61, 64, 65, 71, 75, 84, 620, 621, 622, MEMORY CHIPS, 24LC01, 02, 16, 32, 65
- Read / Write / Copy / Program fuses
- Software supports Microchip, Intel Hex, binary format also supplied with Editor assembler for 54 series and 71/84

Runs on IBM PC / compatible, connects to the centronics printer cable and requires 12-18V AC/DC PSU. Full guarantee. £69.95

Visit our Website at: <http://www.angelfire.com/free/lededge.html> or Email us at: johnmorr@email.keyworld.net

Leading Edge Technology Ltd
White Rose House, Nuffill Street
Lariven PLV 1E, Malva
Tel: 000 356 678509
Fax: 000 356 667484



Postage / packing not included. No VAT or CC surcharges

CIRCLE NO. 122 ON REPLY CARD

The MICRO MODULE
A NEW LOW COST controller
that gives you customisation
for as little as **£95** one off + VAT

and that's just the half of it!..

For users of PCs, 8051 & 68000

FEATURES

- 16/32 bit 68307 CPU for fast operation
- Up to 1 Mbyte of EPROM space onboard
- Up to 512Kbyte SRAM space onboard
- 32 Kbyte SRAM fitted as standard
- RS232 serial with RS485 option
- MODBUS & other protocols supported
- Up to 22 digital I/O channels
- 2 timer/counter/match registers
- I²C port or Mbus & Watch dog facilities
- Large Proto-typing area for user circuits
- Up to 5 chip selects available
- Program in C, C++, Modula-2 & Assembler
- Real Time multitasking Operating System
- OS9 or MINOS with free run time license option
- Manufacturing available even in low volumes
- A full range of other Controllers available

P.C. 'C' STARTER PACK AT ONLY £295 + VAT

The Micro Module will reduce development time for quick turnaround products/projects and with the P.C. 'C' Starter pack allow you to start coding your application immediately, all drivers and libraries are supplied as standard along with MINOS the real time operating system all ready to run from power on. The 'C' Starter pack includes: A Micro Module with 128 Kbyte SRAM, PSU, Cables, Manuals, C compiler, Debug monitor ROM, Terminal program, Downloader, a single copy of MINOS. Extensive example software, and free unlimited technical support all for £295 + VAT.

CMS Cambridge Microprocessor Systems Limited
Unit 17-18, Zone 'D', Chelmsford Road Ind. Est., Great Dunmow, Essex, U.K. CM6 1XG
Phone 01371 875644 Fax 01371 876077

CIRCLE NO. 123 ON REPLY CARD

The right card for every occasion

R.S.V.P.

PC Card
Member Company

Contact Card Professionals for the most advanced portfolio of PCMCIA PC Cards, StarCards, 38edge Cards and compatible interface solutions

- Centennial: major franchised stocking distributor for Centennial PCMCIA cards
- ITT Canon: authorised stocking distributor for 38pin StarCards, 38pin StarCard connectors and 68pin PC Card connectors
- Calluna: authorised stocking distributor for Calluna's type III ATA PC card range
- Centennial: 38 edge card flash memories and connectors

A wide range of Reader/writers are available with ISA, SCSIII, parallel and serial host interfaces for cards in our portfolio



Card Professionals Limited

Card Professionals Limited, Cedarmount House, Owlsmoor Road, Owlsmoor, Sandhurst, Berkshire, GU47 0SS.
Tel: +44 (0) 1344 779632.
Fax: +44 (0) 1344 779633.
www.card-professionals-uk.com

CIRCLE NO. 124 ON REPLY CARD

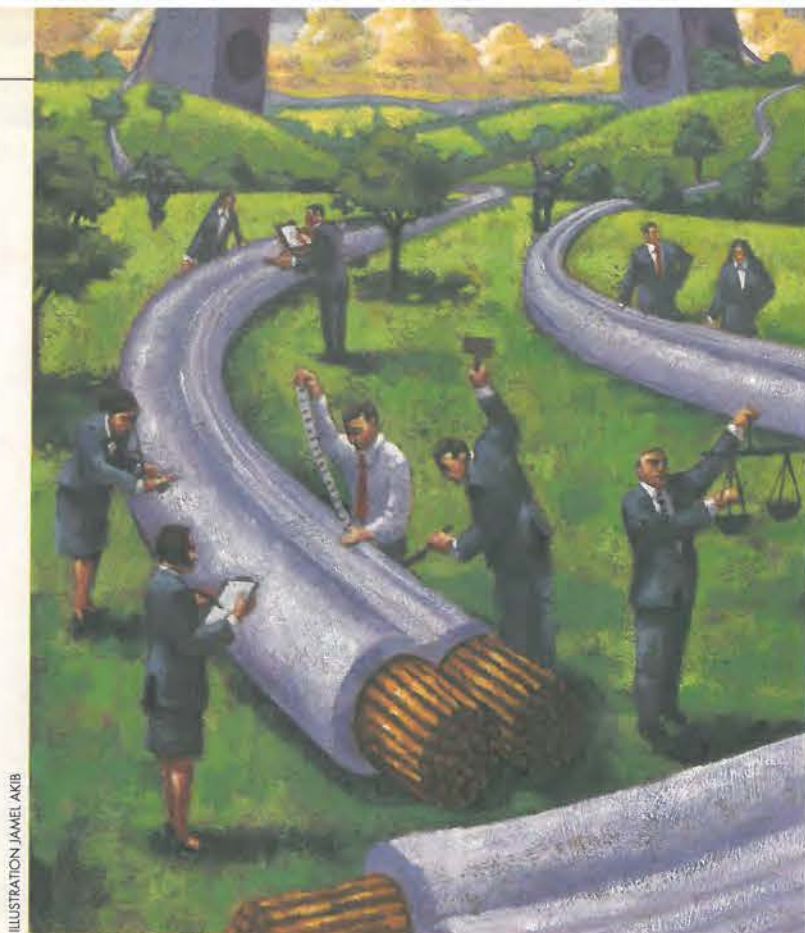

ILLUSTRATION: JAMEL AXB

RF effects on AF

Could mysterious audio power amplifier distortions be explained by rf noise from broadcast stations? Cyril Bateman investigates.

Performing distortion measurements on various speaker cables¹, I noticed and remarked on a level of non-harmonic residue, especially with the figure-of-eight cable styles. This residue was clearly visible on the oscilloscope output of my Hewlett-Packard 331A distortion meter.

The on-screen appearance of this residue supported by its notable absence when testing co-axial cables, led me then to believe it resulted from wideband noise radiated from the 50Hz domestic mains supply.

Recent measurements, using a 3MHz wideband rf millivoltmeter of 1MΩ/20pF input impedance, at the loud speaker terminals in my listening room using my old speaker cables, indicated some 6mV of noise, with my AR amplifier powered but not driven. Subsequent oscilloscope measurements show an amplitude modulated signal around 1MHz in frequency, which could be 'synched' to the trace at 1μs/cm, as well as a multitude of lower and higher frequency noise.

Identification of this rf noise

Further experiments used this double-beam oscilloscope with traces synchronised to an rf signal generator, displaying noise on channel 1 and gen-

erator signal on channel 2.

Slow variation of the rf signal generator frequency, resulted in both traces being stationary at several frequencies. The largest of these stationary traces at 1.05MHz, was visibly amplitude modulated.

Observing this trace while tuning a portable radio with my amplifier switched off, suggested the signal I was watching was 'Talk Radio' on 1053kHz, having some 20mV peak to peak amplitude. Talk radio commenced broadcasting two years ago and since I never listen to medium-wave broadcasts, I was previously unaware of its existence.

Using the scan tuning mode of my AR receiver, I identified seven broadcast transmissions with very high signal strengths in the medium-wave band. Judged by the tuning indicator deflection, the strongest was indeed Talk Radio on 1053kHz, with Radio 5 on 909kHz from Brookmans Park some 170km distant, the weakest noted, **Table 1**.

The medium-wave broadcasting band, extending from 526.5kHz to 1606.5kHz, is covered by a large number of transmitters, many being of very high power, so it was no surprise that many other weaker signals were obtained using manual tuning.

The long-wave broadcasting band extends from

148.5kHz to 283.5kHz, it also has a number of powerful transmitters giving coverage throughout UK.

Powerful non-broadcast transmissions at frequencies very much lower than the long-wave band are used for long distance data or time code transmissions. The National Physical Laboratory at Teddington transmits the MSF time signal from the 50kW Rugby transmitter, a far reaching signal, at 60kHz.

Advice from the BBC² and Radio Authority³ engineering departments stated the service limit for medium-wave broadcasts is a minimum signal level of 2mV/m, with 5mV/m required for long wave. Any clearly received broadcast will thus much exceed this field strength at your location.

The engineer's field strength contours for my location, suggested for 'Talk Radio' a field strength of 100mV/m. This level is by no means unique. Examination of the various broadcast transmitter locations and powers suggests much greater levels are common.

With the most powerful transmitters being located close to densely populated regions, locations in the Home Counties, West Country, Midlands, Yorkshire, North East, Scotland and Northern Ireland, situated close to these transmitters could experience field strengths exceeding 500mV/m (see the panel on propagation). However the frequencies of highest strength may differ from those I found, **Table 2**.

These medium and long-wave transmissions are not unique to the UK, but are controlled under internationally agreed standards and used in many countries. Transmissions from Europe are frequently received in the eastern counties of the UK, as demonstrated by my unidentified foreign station on 1395kHz, **Table 1**.

Could these signals affect audio power amplifiers? In order to find out, the complete circuit involved in the closed feedback loop within the amplifier and the amplifier components outside this feedback loop has to be considered. This includes the loudspeaker cable parameters, loudspeaker crossover network and the speaker drivers in their cabinet.

Depending on the amplifier's design, a varying level of audible distortion, or significant

Low and medium-frequency rf propagation

This discussion involves frequencies between 30 and 3000kHz. Since it is almost impossible to build a quarter-wave vertical antenna for this frequency band, transmission invariably results from short vertical antennas at low heights above ground. At these frequencies the main reception mechanism results from ground-wave propagation. This is attenuated both by increased distance and frequency, also the ground and sub-surface conditions the wave travels over.

Given a near perfect ground surface – e.g. sea water – the theoretical figure for propagation will be approached,⁸

$$E=300P^{1/2}$$

at 1km, where *P* is radiated power in kW and *E* is rms mV/m. Over land this figure³ is commonly reduced to,

$$E=221.8P^{1/2}$$

When directional aerials are used, the above figures must be suitably modified.

Low-frequency ground-wave propagation initially reduces almost inversely with distance, but rather more rapidly as distance or frequency increase, to some 110dB loss at 160km compared to 64dB loss at 16km, both assuming a frequency of 1MHz⁸.

Note that the above description has been greatly simplified; refer to the references for more details.

Table 1. Locally received high signal strength medium and long wave transmissions, strongest listed first. Data based on BBC and Radio Authority engineering information, confirmed by measurements using a 1m vertical whip antenna and wavemeter.

Program name	Frequency (kHz)	Transmitter location	Radiated erp (kW max)	Distance to test site (km)	Field strength mV/m est.
<i>Medium Wave</i>					
Talk Radio	1053	Postwick	18	10	100
Radio 5	693	Postwick	10	10	40
Foreign	1395	Unknown			30
Radio Broadland	1152	Brundall	0.83	8	25
Radio Norfolk	855	Postwick	2	10	18
Virgin Radio	1215	Postwick	1.2	10	14
Radio 5	909	Brookmans Park	150	170	12
<i>Long Wave</i>					
Radio 4	198	Droitwich	500	250	20

increase of noise levels, resulting from 20mV rf signals, has previously been reported⁴. Subsequently, many amplifiers now have in-built protection against rf energy presented to their input terminals but not similar dedicated protection for their output terminals.

The possibility that "audible intermodulation

products can arise from spurious signals with frequencies above human hearing" was also touched on by Ivor Brown⁵ in a letter to Douglas Self.

Most amplifiers have a low value output inductor and Zobel capacitor resistor network between their feedback loop and their output

Table 2. Listing of major long and medium-wave transmitters of 50kW and above, based on BBC and Radio Authority engineering information. Some sixteen other transmitters have power outputs between 5kW and 50kW, with a further two hundred and eight below 5kW.

National LW/MW transmitter sites	Frequency (kHz)	Radiated erp (kW max)	Frequency (kHz)	Radiated erp (kW max)	Frequency (kHz)	Radiated erp (kW max)	Map reference
Brookmans Park	909	150	1,089	400	1,215	125	TL259050
" "	1458	125					" "
Burghead	198	50	810	100			NJ125685
Clevedon	909	50					ST400697
Droitwich	198	500	693	150	1053	500	SO929663
" "	1215	105					" "
Lisnagarvey	1341	100					I258619
Moorside Edge	909	200	1,089	400	1,215	200	SE070154
Stagshaw	693	50					NY986709
Start Point	693	50					SX814378
Washford	882	100	1089	80	1215	100	ST058410
Westerglen	198	50	810	100	909	50	NS868773
" "	1089	125	1215	100			" "
Saffron Green	1548	97.5					TQ216977

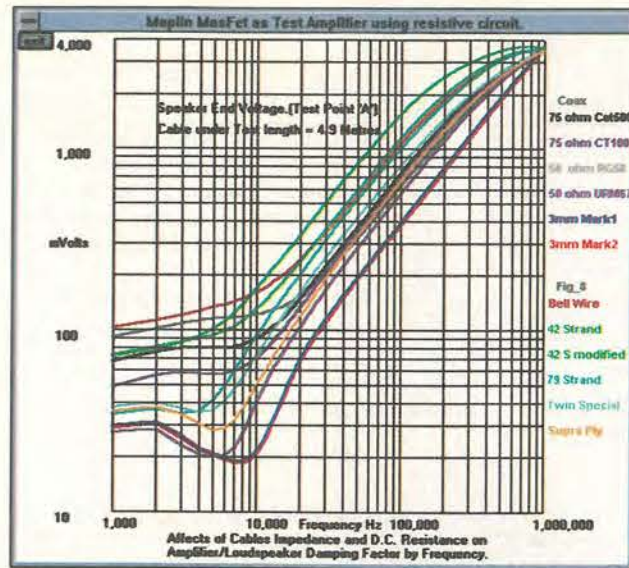

Fig. 1. Speaker end damping voltage by test cable and frequency using Maplin mosfet amplifier.

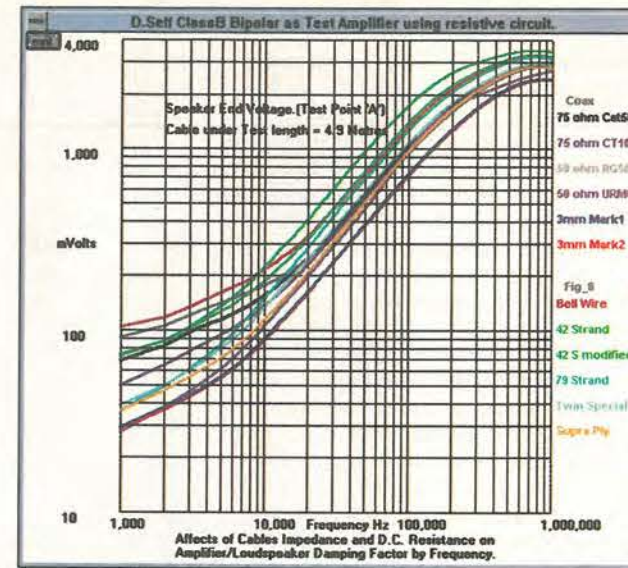

Fig. 2. Speaker end damping voltage by test cable and frequency using D. Self's bipolar amplifier.

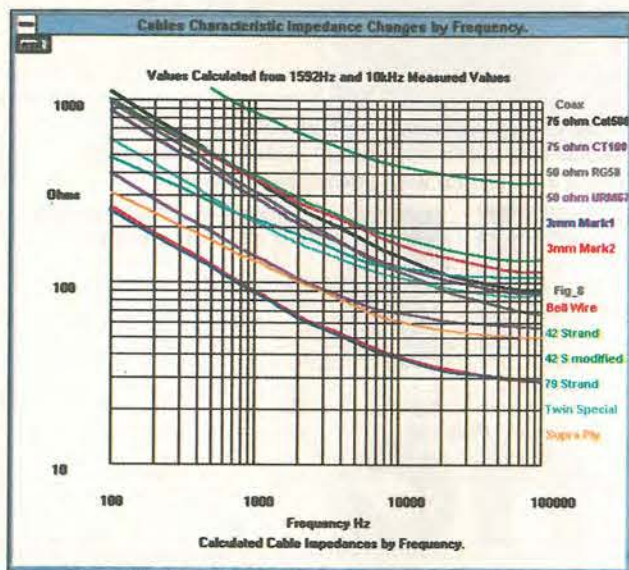

Fig. 3. Test cable characteristic impedance by frequency.

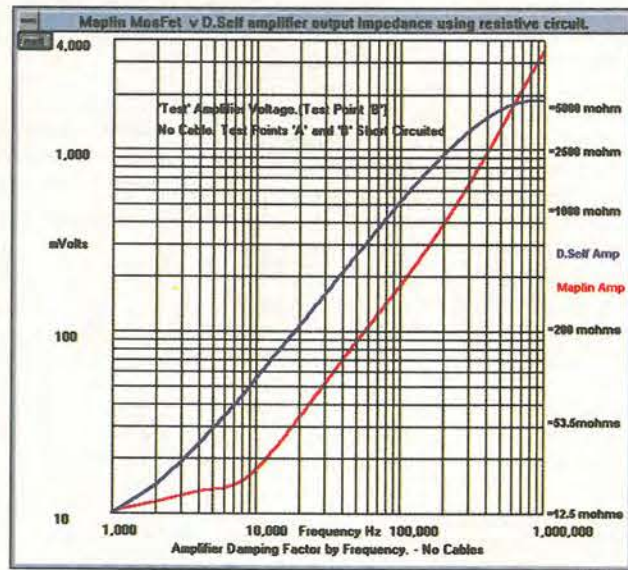

Fig. 4. Comparison of Maplin mosfet and D. Self bipolar amplifier output impedances by frequency. Notice the diverging behaviour of these amplifiers at the higher frequencies.

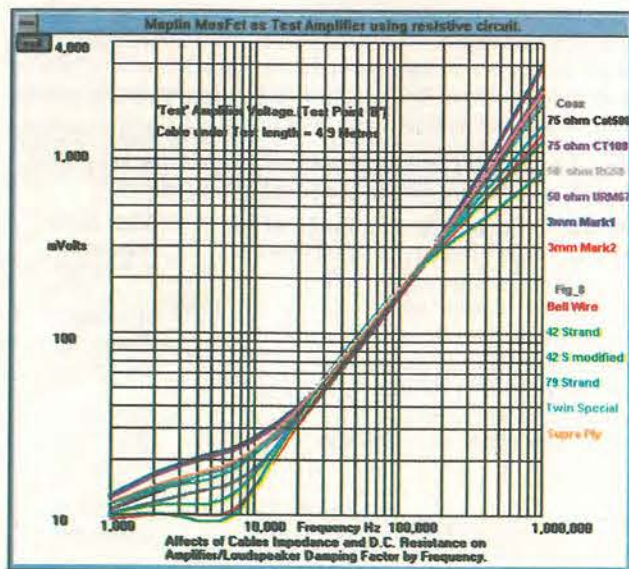

Fig. 5. Amplifier-end damping voltage by test cable and frequency using Maplin mosfet amplifier. Notice the diverging behaviour of this amplifier compared with Fig. 6, at the higher frequencies.

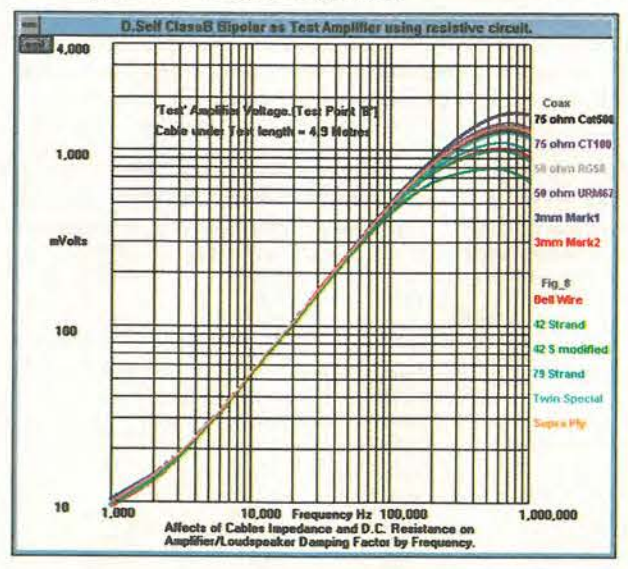

Fig. 6. Amplifier-end damping voltage by test cable and frequency using D. Self's bipolar amplifier. Notice the diverging behaviour of this amplifier, compared with Fig. 5, at the higher frequencies.

terminals. This is added to improve stability with reactive loads.

All inductors have an inevitable level of distributed self capacitance – several picofarads in value – effectively in parallel with the inductor. The capacitance of printed board tracks from the inductor's terminals, also appears effectively in parallel with the inductor. Depending on these inductance and capacitance values, the combination will 'parallel' resonate at some high frequency. At frequencies above this resonance the inductor will act as a capacitor and its effective series impedance reduce with frequency increase.

At frequencies below this resonance, the output inductor and Zobel Network should reduce the level of rf signal measured in the feedback loop, compared to that injected at the amplifier output terminals.

The level of rf measured at the amplifier output terminals depends on the amplifier's effective output impedance combined with the characteristics of the cables and speaker used, at these rf frequencies.

My previous articles measured cable characteristics and amplifier output impedance for two representative amplifiers⁶ but only to 100kHz. These measurements were repeated with frequencies extending from 1kHz to 1MHz, to clarify the working impedances that need be considered, Fig. 1-6.

The rf millivoltmeter measurements show the average of the signal levels involved. Since these also include amplifier and other audio frequency noise sources, a means to identify signal levels by frequency is needed. Obviously an rf spectrum analyser is ideal, however a wavemeter will suffice.

As a minimum, a wavemeter requires only an air-variable capacitor and suitable low loss inductor, housed in a fully screened enclosure, used as a pre-selector for the rf millivoltmeter. The variable capacitor must of course be fitted with a suitable reduction drive and dial to facilitate retuning to known frequencies. (see box 'What is a wavemeter?').

Having a Muirhead precision 50-1250pF air variable capacitor, with precision reduction drive fitted with a four-digit readout dial, already housed in an extremely substantial diecast case, I needed only to add the inductor, coupling capacitor and two BNC connectors. A frequency calibration chart, using my rf generator together with off air signals picked up by a 1m square-loop aerial, was quickly plotted.

My Self amplifier was already housed in a

What is a wavemeter?

Essentially, a wavemeter consists only of a tuneable parallel circuit of a low loss variable capacitor with a low loss inductor. One common connection is grounded to earth and the circuit is loosely coupled to the antenna system. This loose coupling can comprise a tapping on the coil winding, a coupling coil winding or a low value capacitor between the 'hot' common connection and the aerial.

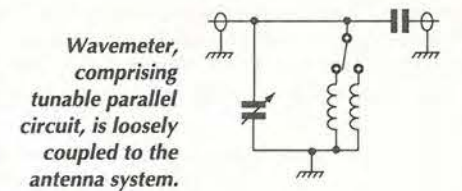

When used with higher impedance antennas, very high Q can be attained with tight frequency discrimination. Small single-turn loop antennas – especially when connected to the low impedance of an audio amplifier/speaker system – will achieve low 'Q', with consequently broader tuning. This is regardless of coupling method used.

The wavemeter circuit used here incorporated a 50-1250pF air variable capacitor and a 47pF coupling capacitor. Since they were to hand at the time, for frequencies below 1100kHz I used a 55µH air core, switching to a 25µH air core for the higher frequencies.

Due to its high input impedance, I was able to connect my rf millivoltmeter directly to the hot end of the tuning capacitor.

Table 3. Wavemeter measurement of rf pick-up at output terminals of D. Self amplifier, with wavemeter used to select individual transmission frequencies. Workroom location as used for distortion measurements, also listening room amplifier location for comparison. Field strength measured using a 1m square single-turn loop aerial connected directly to wavemeter. All cables were 4.9m long.

Cable under test	693kHz (µV)	909kHz (µV)	1053kHz (µV)	1152kHz (µV)	1395kHz (µV)
Coaxial styles					
75Ω Cat. 500	41	51	110	42	45
75Ω CT100	40	52	106	40	44
50Ω RG58C/U	42	52	115	40	40
50Ω URM67	41	52	105	44	46
3mm Mk I	42	53	113	44	46
3mm Mk II	41	54	113	46	46
Fig. of 8 styles					
2192Y bell wire	56	60	520	91	157
42 strand	56	62	540	96	170
42 strand modified	56	63	560	112	180
79 strand	59	63	570	100	173
2mm twin special	56	62	520	91	163
Supra-Ply 2.0	58	63	560	86	152
With 8.2Ω termination only	32	35	52	34	33
Loop-antenna field strength	2200	2500	20 000	7600	8200
Using D. Self amplifier with old listening-room cables	320	520	5600	1050	1300

Detailed on page 124 of the February issue, the MkI and II cables are custom fabricated, very flexible and less than 6mm in diameter. The MkII has a 19-strand, 0.45mm inner wire insulated with polythene with a 3mm outside diameter. Its outer braid is 240 strands of 0.127mm wire. Heat-shrink tube provides overall insulation. MkI is identical, except for its 37 strands of 0.32mm inner core.

Table 4. RF voltage levels, in millivolts, within the two power amplifiers tested, measured using oscilloscope probe. Signal generator output was applied to the amplifier output terminals with level set to 10mV, measured at pc board output pads (V2).

Measuring point	D. Self amplifier			Maplin amplifier		
	900kHz	1000kHz	1100kHz	900kHz	1000kHz	1100kHz
Amplifier terms. V1	11.2	11.4	11.3	10.8	10.5	10.6
At pc board out. V2	10.0	10.0	10.0	10.0	10.0	10.0
At Zobel network V3	1.26	1.4	1.55	7.1	7.8	7.2
Self Tr ₃ base V4	0.41	0.52	0.66			
Maplin Tr ₂ base V4				0.48	0.44	0.17

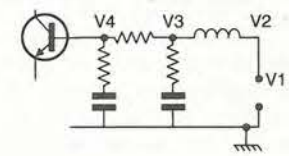

Measurement points, simplified. Node V1 is the amplifier output terminals while V2 is the same output point at the pcb.

Table 5. Wavemeter measurement at 1053kHz of rf pick-up at D. Self amplifier output terminals. Using figure-of-eight cables in balanced and un-balanced configuration to connect to loudspeaker system alternately to 8.2Ω dummy loudspeaker load. Balun transformer made with 30 twisted bifilar turns of 0.5mm wire, wound on TMC107523 toroidal core, which was un-balanced using removable link from earthy output to one wire of figure-of-eight cable. Cables 4.9m long.

Table with 4 columns: Cables under test, Balanced w. balun (µV), Unbalanced w. balun (µV), Unbalanced with cable direct wired (µV). Rows include 'With speaker load' and 'With 8.2Ω load' for 42 strand and 42 strand modified cables.

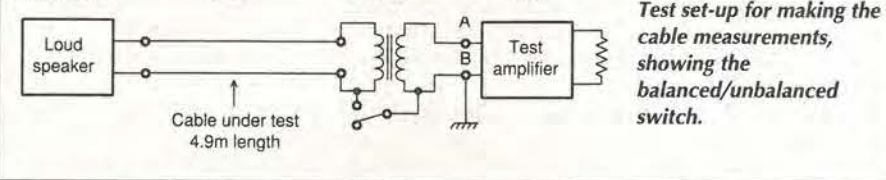

Test set-up for making the cable measurements, showing the balanced/unbalanced switch.

Table 6. RF millivoltmeter measurements, in microvolts, of pick-up with amplifier replaced by dummy amplifier loading network of output inductor with 10Ω shunt resistor, a Zobel network and 0.033Ω termination resistor. Measured at this dummy load, with crossover or cable screened in turn, to determine proportion of noise pick-up due to crossover/speaker and cable under test. Shows excessive rf pickup with figure-of-eight cable. Cables 4.9m long.

Table with 5 columns: Cable under test screened, In normal use, W. Xover screen, Cable screened, Both. Rows list various coax styles (75Ω Cat. 500, 75Ω CT100, etc.) and fig. of 8 styles (2192Y bell wire, etc.).

substantial aluminium screened case. I measured the wavemeter output, for five of the locally strong medium-wave frequencies, at the amplifier output terminals with the amplifier powered but not driven. The rf pick-up from the twelve test cables and speaker system, was measured using the same cable locations and orientation as for the distortion measurements, Table 3.

This wavemeter/amplifier measurement system was also used to measure the signal levels picked up by the old cables in my listening room. These were significantly higher due to increased cable lengths, the cable's direction and proximity to the ring mains.

Having established the frequency and voltage levels at the amplifier terminals when used with the various test cables, attempts were made to measure similar signals within the amplifier. Obviously should its output amplifier sufficiently block these signal levels from entering the amplifier. In this way, the rf signals could not cause any audible intermodulation distortion.

With my rf signal generator set to a test frequency of 1MHz, I used HP9100 oscilloscope probes to connect the test points to my rf mil-

liovoltmeter. With the signal generator output applied to the amplifier output terminals and signal level set to 10mV measured at the amplifiers pcb output pads (V2), I measured 1.4mV at the 'Zobel' network and 0.52mV at Tr3 base, of the Self amplifier. Having established that for this design a measurable rf level can be found within the feedback loop, the measurements were repeated for 900kHz and 1.1MHz, then with the Maplin amplifier. Table 4.

Having now confirmed that rf signals picked up on speaker cables can intrude within the amplifier, and that this rf level differs substantially between figure-of-eight and co-axial cable styles, how are these signals picked up? Just what is the pickup mechanism?

RF pick-up mechanisms

A single-turn loop antenna can be formed by winding coaxial cable around a wooden frame and connecting the outer braid free end to the inner feeder conductor at the completion of the loop. Its termination at the receiver is unbalanced, i.e. the braid is connected to earth.

Alternatively an antenna can comprise a figure-of-eight cable partially unzipped, with

each unzipped wire wrapped around one half of the frame, the free ends then being joined to complete the loop. Using balanced termination at the receiver minimises any stray pickup on the cable connecting the loop antenna to the receiver. This balanced termination is important, since any unbalanced figure-of-eight or twin feeder cable will both transmit and receive signals.

Signal pickup depends on the area enclosed by the loop, and while pickup of higher frequencies is quite good it discriminates heavily against much lower frequencies. The cable/amplifier rf pickup measurements of Table 3 also show similar frequency discrimination.

When a figure-of-eight cable is used with a conventional amplifier as a loudspeaker cable, one line of the cable is earthed by the amplifier's 'low' output terminal, the cable is clearly unbalanced. The speaker ends of the cable are terminated by the speaker's rf impedance. Hence the figure-of-eight test cable and speaker system could form a very shallow single-turn loop aerial.

To put this to the test, I wound a simple 1:1 balun transformer, of some 50µH primary inductance, and re-measured the rf picked up by the 42-strand figure-of-eight cables. If the above analogy was correct, I expected a notable reduction in rf when measured with the figure-of-eight cable balanced to earth, versus the same cable deliberately unbalanced.

Using my wavemeter set to 1053kHz, approximately half the level of rf signal was measured with cables balanced compared to the same system unbalanced. To eliminate the balun transformer losses from clouding these results, the balun and its connections with the test cable were retained for both measurements. A temporary earth link, connecting amplifier 'low' output to one line of the figure-of-eight cable, was used to establish the unbalanced state, it was removed for the balanced configuration, Table 5.

Regardless of loudspeaker cable used, the speaker cabinet wiring and the inductors used in any crossover network, will also function as antennas with some degree of rf signal pickup. Since speaker and crossover systems vary widely in their construction and thus potential for rf pickup, this has not been investigated other than to clarify the relative pickup levels with my test speaker system.

The methods used were both simple and effective. I decided to measure rf levels with the speaker and cables arranged exactly as for the distortion measurements. Next they were measured with the crossover network screened by a Faraday shield, and finally with the speaker cable similarly shielded. Not having a suitable metal container easily able to contain my test speaker cabinet, or my amplifier complete with the test cables, I needed to simplify the task.

The crossover had previously been moved outside the speaker cabinet for the distortion measurements. Connection to both drivers involved short lengths of 42-strand figure-of-eight cable. Replacing the amplifier with a

dummy load allowed the test cable leads to be easily coiled up and screened. Grounding one dummy load terminal ensured the figure-of-eight test cables remained unbalanced at one end, exactly as in normal use.

This dummy amplifier load was made up using a typical output inductor, Zobel network and 0.033Ω resistor to replace the amplifier. A few experiments confirmed my metal wastebasket, suitably earthed, served as an excellent Faraday shield.

Using the rf millivoltmeter, I measured the voltage levels at this dummy amplifier load for each of the 12 test cables. First, I measured with nothing shielded, next with the crossover only shielded, then with the cables coiled up and placed in the shield, and finally with both cable and crossover shielded.

In every case, the greatest reduction of measured rf resulted from simply screening the cable, thus clarifying the cable's pickup is the major contributor to rf pickup with this speaker. While measurable changes were found for all cables, the unbalanced figure-of-eight cables were found to be particularly prone to rf pickup, Table 6.

Coaxial cable definitely is best

Due to the considerable variations in amplifier design and thus potential sensitivity to rf, no attempt has been made to confirm whether these rf signals caused measurable or audible

distortions with either test amplifier. However the work published by Paul Miller⁴ suggests this is more than likely with most amplifier designs, given sufficient rf levels.

However, these signals cannot be beneficial and are thus best avoided. Using coaxial cables with a conventional inductor output amplifier minimises this rf pickup. When combined with the other benefits already established in my previous articles, there remains no good reason for not changing to coaxial speaker cables.

One final proviso, the output terminals of two amplifiers arranged in a bridge output configuration may be truly balanced with a valve amplifier could also be balanced if neither terminal of the output transformer secondary winding were tied to earth.

When amplifier output terminals are balanced to earth at rf, to be effective in reducing rf pickup, coaxial cables must be wired correctly. The inner cores should only be used to convey signal power, with the inner of a second coaxial cable used to return the signal. The amplifier end of each braid should be connected to earth, providing a Faraday shield for each signal conductor.

With a conventional amplifier system, the coaxial cable inner wire is connected to the 'hot' terminals at the amplifier and speaker system, with the outer braid connected to both

the amplifier and speaker 'cold' terminals. This completes the return path while shielding the amplifier's hot output terminal from rf pickup.

In summary

Having brought this anomaly of noise signals to a conclusion, work is now proceeding rapidly to refine the MkII coaxial cable design to give even more improved performance, reduce materials cost and improve ease of manufacture.

References

- 1. Bateman, C, 'Speaker Cables', Electronics World, Feb. 1997, pp. 119,124.
2. BBC Engineering Information, Villiers House, The Broadway, Ealing, London W5 2PA.
3. Radio Authority, Holbrook House, 14 Great Queen St, Holborn, London WC2B 5DG.
4. Miller, P, 'Resonances and Repercussions', Hi-Fi News & Record Review, June 1989, pp. 35,37.
5. Brown, I, 'Silent Problems', Letters, Electronics World & Wireless World, Feb. 1994 p. 125.
6. Bateman, C, Measuring speaker cables, Electronics World & Wireless World, Jan. 1997, p. 55.
7. Aerials, feeders and arrays, sect. 37, Admiralty Handbook of Wireless Telegraphy, HMSO.
8. Reference Data for Radio Engineers, Sams, section on Electromagnetic wave propagation.

Telford Electronics advertisement featuring a large logo and a detailed list of electronic components such as signal generators, amplifiers, and test equipment with their respective prices.

Applying double-balanced mixers

Darren Conway illustrates how to get the best from double-balanced diode mixers.

Double-balanced diode mixers are widely used in communications equipment. Their wide dynamic range and relatively low noise has made them a popular choice.

When properly applied, very good results can be obtained with diode mixers, but designing circuits that include them is not a trivial task. The main difficulty with applying the double balanced diode mixer is that mismatch at any of the three ports degrades performance.

These mixers are particularly sensitive to mismatch at the IF port, which results in greater conversion loss and the generation of unwanted mixer products. Ideally, the IF port should be terminated into a post mixer filter with a constant input impedance and a low pass frequency response.

This article uses simulation to compare various designs for post mixer IF filters with the purpose of identifying an optimum design.

Applying diode mixers

The following research was completed as part of the design of a satellite receiver capable of detecting low earth orbital satellites transmitting on about 137.6MHz. The design is an entirely conventional double superheterodyne. Its first intermediate frequency is 37.5MHz selected largely because of the ready availability of cheap and effective SAW filters commonly found in televisions.

Surface acoustic wave filters are physically small, require no tuning, and are easy to interface. The type used features a 3MHz band width. This means that it is also suitable for the front end of a receiver designed for high data rates available from many satellites.

For the first mixer, a double balanced diode type was

selected because of the wide dynamic range and a relatively good noise figure. The wide dynamic range is necessary so that the weak satellite signals can be received in the presence of strong interference from any nearby transmitters. A low noise figure improves the ability to detect and demodulate very weak signals.

Matching problems

The effect of termination mismatch on a double balanced diode mixer is not the same for each port. Mismatch at the rf port is the least problematical, which is fortunate because in many applications it is not practical to match to this port. Mismatch between the local oscillator and the mixer degrades third-order performance but can be improved simply by adding a -3dB 50Ω pad. The output level of the local oscillator needs to be adjusted to overcome the loss. The effects of having each port reactively terminated are shown in Table 1. Performance is degraded even further if more than one port is mismatched.

To achieve minimum conversion loss through the diode mixer and prevent harmonics reflecting back into the mixer, it is particularly important that the IF output is correctly matched to a 50+j0Ω resistance.

If the term $F_{LO}+F_{RF}$ is reactively terminated, then it will reflect back into the mixer and combine in anti-phase with the local oscillator to produce the terms $F_{LO}+F_{RF}-F_{LO}$, and $2.F_{LO}+F_{RF}$. This causes conversion loss and produces spurious responses.

It is not sufficient to properly match the IF port to the low order harmonics. In order to achieve the best performance from a mixer, it is necessary for the IF port to be terminated with a 50+j0Ω resistance over an extensive frequency range.

Table 1. Effects of terminating the double-balanced diode mixer's ports reactively.

Termination condition	Conversion loss	RF compression level	RF desensitisation level	Harmonic modulation products	Third-order IM products
IF=reactive	can vary ±3dB	can vary ±3dB	can vary ±3dB	can vary ±20dB	can vary ±20dB
LO=reactive	No effect if LO drive adequate	No effect if LO drive adequate	No effect if LO drive adequate	can vary ±10dB	can vary ±10dB
RF=reactive	Typically ±0.5dB for 2:1 vswr	±0.5dB	±0.5dB	No first-order effect	No third-order effect

*source, reference 3

In this application, it means that the post mixer IF filter should be matched to at least 200MHz. Proper matching at higher frequencies is highly desirable.

It is possible to achieve good matching by terminating the IF output with a 50Ω resistor followed by a post mixer IF amplifier. The problem with this method is that the amplifier applies equal gain to all harmonics in addition to the wanted IF. This increases the risk of over driving the post mixer amplifier and generating additional harmonics.

The diode mixer should therefore be followed by a low pass filter with a constant input impedance of 50+j0Ω. Output of the filter should then be matched to the IF amplifier.

Specifying the IF filter

The intention in this application was to find an efficient IF filter circuit that gave the best performance from the least number of components. The desired specifications of the IF filter are as follows:

- A return loss of no less than -20dB across the frequency spectrum as specified by the diode mixer manufacturer.
- Insertion loss of no more than -0.25dB. The insertion loss adds directly to the noise figure of the mixer and should be as low as possible.
- No more than three inductors. Limiting the number of inductors in a filter automatically limits the filter order and complexity.
- A low-pass filter function with a roll off of at least -18dB/octave. Good frequency roll off is required because the low-order, high-amplitude mixer products are relatively close to the IF.
- Easy to design, build and set up.

Analysing performance

Analysis of the circuits described below was completed using the MicroSim version 6.2 Spice simulator. The quality of the circuits was evaluated using four parameters.

Return loss was calculated using the network of resistors R_{1-4} and a 2x voltage gain block⁷ to provide a voltage across R_{d1} which is plotted as $VdB(R_{d1})$.

Ideally, the return loss should be very large across the frequency spectrum, indicating that energy has been efficiently transferred from the mixer output to the filter circuit. A small return loss approaching 0dB indicates that all energy is being reflected back to the source.

Resistor R_c which has a value of 1μΩ is used as a sense resistor to measure current and voltage applied to the test circuit. Input impedance is calculated using the voltage and current passing through R_c and is plotted as $V(R_c:1)/I(R_c)$.

The variable $-I_p(R_c)$ measures the angular phase of the input current. Input current phase indicates the reactance of the test circuit. A purely resistive circuit will have zero phase shift. A capacitive or inductive component will cause the current phase to rotate. In this application, the IF filter should ideally be purely resistive at all frequencies.

The frequency response is measured across the load resistor R_l . All IF filters analysed here have been designed for an IF of 37.5MHz, but the values can easily be modified for other frequencies. Plots of these four parameters are combined on single graphs and fully define the important characteristics of the IF filters under test.

LC tuned tank

The LC tuned tank circuit, Fig. 1 represents a simplistic solution to the IF filter problem that has been used in early receiver designs. It consists of an LC pair tuned to the IF at which point it appears to have a 50+j0Ω input impedance. This is shown in the Spice analysis in Fig. 2, where at

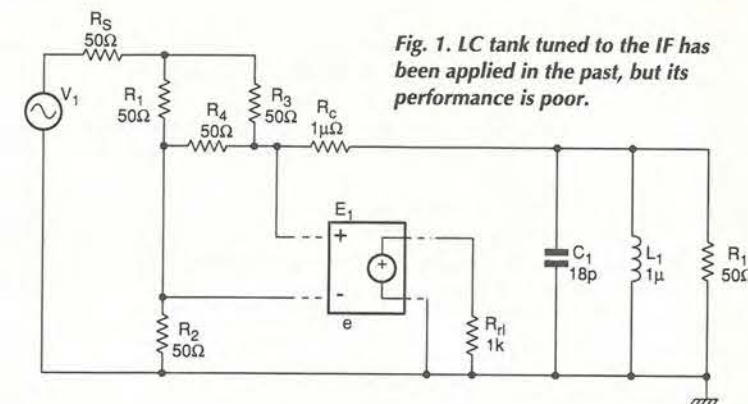

Fig. 1. LC tank tuned to the IF has been applied in the past, but its performance is poor.

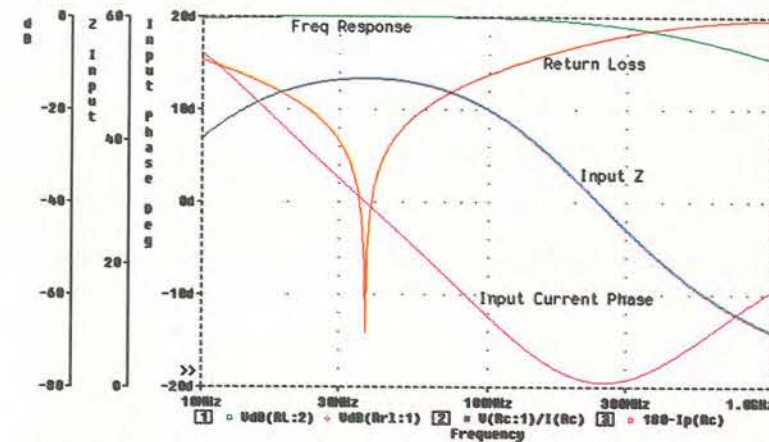

Fig. 2. Analysis of the LC tuned tank, Fig. 1.

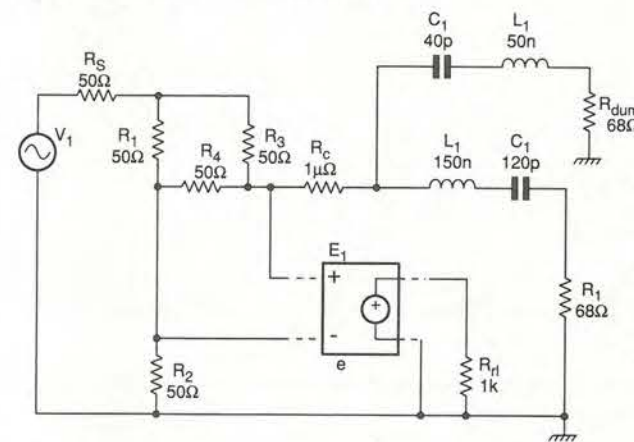

Fig. 3. Series tuned diplexer. Although this circuit is an improvement on the LC tank, its performance is far from ideal.

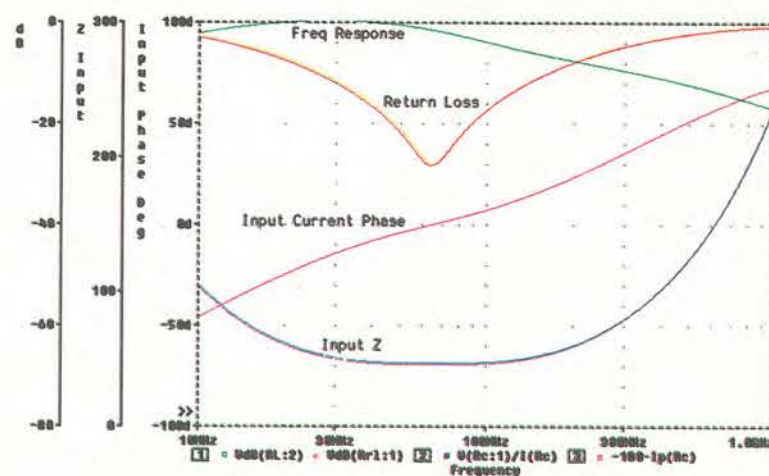

Fig. 4. Analysis of the series tuned diplexer, Fig. 3.

37.5MHz the input impedance is 50Ω, the input current phase is 0° and the return loss is very high.

At all other frequencies the circuit is reactive and reflects significant harmonics back into the mixer. The frequency response is particularly poor giving only -1dB attenuation at 200MHz.

The LC tuned tank circuit demonstrates all the undesirable features of a bad IF filter. Any receiver that uses this circuit would probably give better performance if the capacitor and inductor were removed, leaving only the 50Ω resistor.

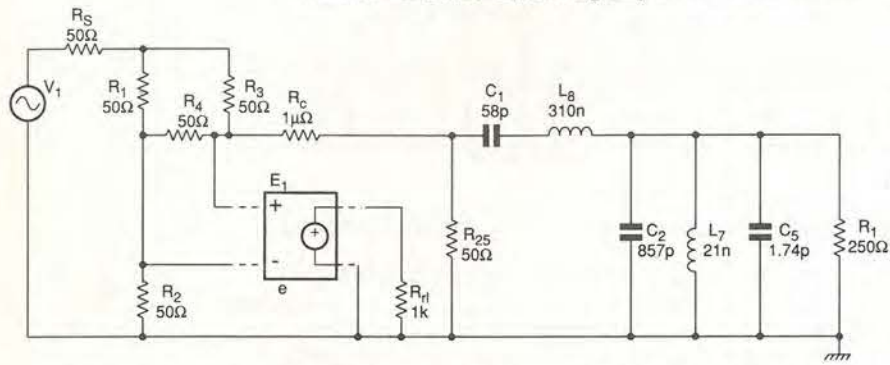

Fig. 5. IF filter comprising a Butterworth band-pass circuit. One of its useful features is that it displays constant impedance through the pass band.

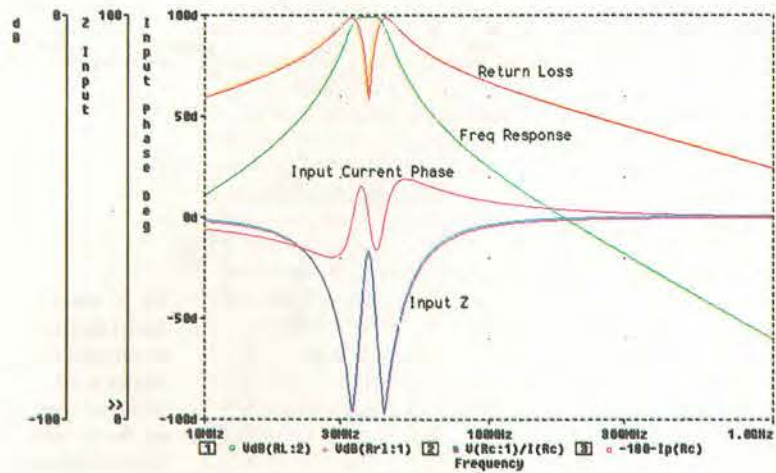

Fig. 6. Analysis of the Butterworth band-pass IF filter, Fig. 5, with 37.5MHz centre frequency and 10MHz band width.

Fig. 7. IF filter using a Butterworth diplexer with separate high and low-pass elements.

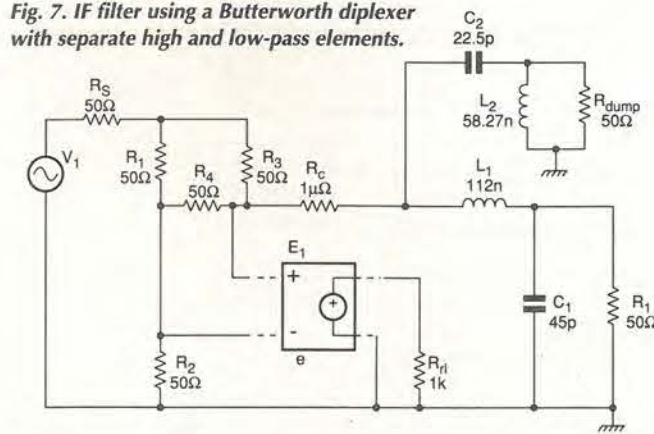
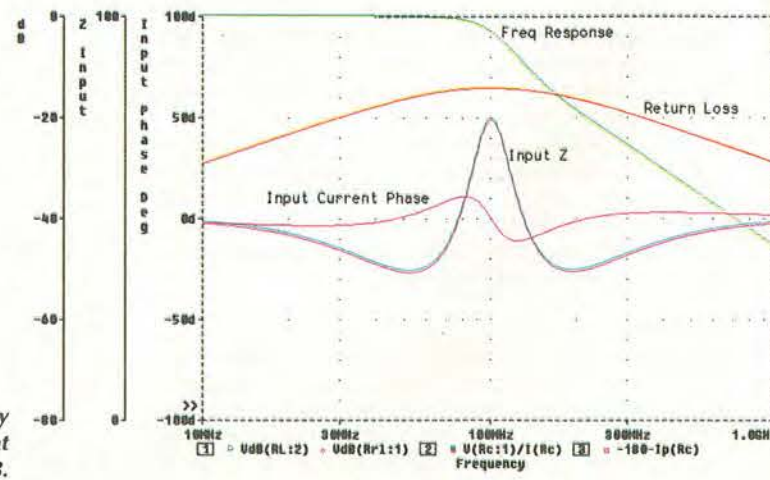

Fig. 8. Analysis of the 100MHz centre-frequency Butterworth diplexer, Fig. 7, shows that attenuation at 200MHz is a modest -18dB.



Series-tuned diplexer

The series-tuned diplexer design is intended to terminate both the IF and the third-harmonic (3.IF) into 50+j0Ω loads. This circuit is designed to provide a resistive termination to the most troublesome low-order mixer products.

Values of the inductors and capacitors shown in Fig. 3 were selected simply to resonate at the correct frequencies. You can see from Fig. 4 that the input impedance is reasonably well matched between about 25MHz and 150MHz. Normally the signals are terminated into 50Ω resistors but analysis showed that 68Ω resistors are required to achieve a 50Ω input impedance.

The plot of input current phase shows that this filter is reactive at all frequencies except one. This characteristic combined with the increasing impedance at higher frequencies means that harmonics will be reflected back into the mixer.

Frequency response is also poor providing only -7dB attenuation at 200MHz. Although this circuit is an improvement on the LC tank circuit, the performance is far from ideal.

Butterworth band pass

An IF filter based on a band-pass Butterworth filter appeared to offer some hope. One of the useful properties of Butterworth filters is that they ideally display a constant impedance through the pass band.

Outside the pass band, the impedance increases or decreases depending on the filter topography. In addition, they can be designed to have different input and output impedances.

The filter shown in Fig. 5 is designed with a pass band centred at 37.5MHz and a 10MHz band width. The input is matched to a source impedance of 25Ω defined by the impedance of the mixer and the 50Ω resistor.

Output impedance of the filter is 250Ω, intended to provide some degree of matching to the IF amplifier. The analysis results in Fig. 6 show an improvement in overall performance compared to the previous filters but there are still major flaws with this circuit. The insertion loss of -0.8dB in the pass band is higher than desired but attenuation at 200MHz is a healthy -52dB. The return loss and input impedance vary significantly over the pass band, which is likely to create unwanted reflections from received signals close to the rf input. From a practical constructive view, the 21nH inductor is a very small value and would be difficult to implement. The sharp dip in the return loss at 37.5MHz makes this filter sensitive to component drift and tuning errors.

Although this circuit offers reasonable performance in theory, it would be very difficult to construct and tune. It is therefore not recommended.

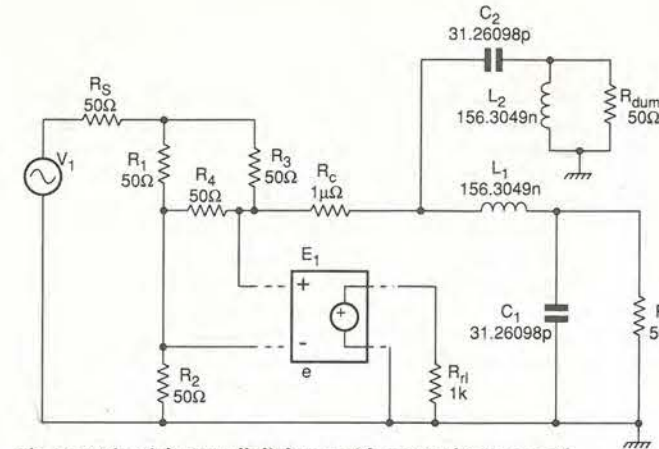

Fig. 9. Weinreich-Carroll diplexer with centre frequency of 72MHz exhibits insertion loss of -3dB at IF.

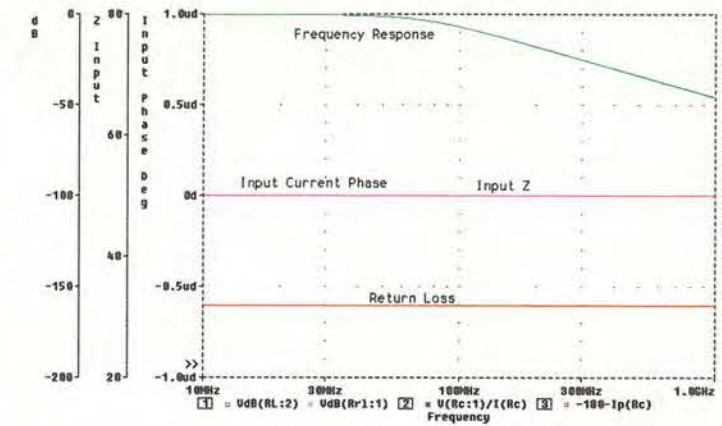

Fig. 10. Weinreich-Carroll diplexer analysis. Although simple, this circuit achieves perfect matching across the entire rf spectrum.

Butterworth diplexer

As a variation to the Butterworth filter theme, separate high-pass and low-pass filters were configured as a diplexer centred on 100MHz as shown in Fig. 7.

The results show that this circuit has better characteristics than the Butterworth band-pass filter above. At worst the return loss is -14dB which is 6dB less than the required value of -20dB. Both the input impedance and the input current phase remain reasonably close to ideal across the frequency spectrum.

Upward deflection of the frequency response plot at 150MHz is due to interaction between the high and low pass sections at their inputs. Insertion loss at 37.5MHz is only -0.084dB while attenuation at 200MHz is a modest -18dB.

None of the plots exhibits any excessively sharp peaks or dips which in this case means that the circuit is tolerant to component errors and drift. The values of the inductors are not too widely spread and are large enough to allow a practical filter to be constructed.

This circuit has the same number of components as the diplexer shown in Fig. 3 and yet displays superior performance. In spite of this, the Butterworth diplexer does not conform to the required specifications and a better solution was sought.

Weinreich-Carroll diplexer

The Weinreich-Carroll diplexer¹ is a second-order filter designed so that all capacitors and inductors have an impedance of $\sqrt{2} \times 50 = 70.7$ at the centre frequency. A centre frequency of 72MHz was selected for this circuit, being the geometric centre between the IF and the image, $\sqrt{(F_{IF} \cdot F_{LO+IF})}$. This results in an insertion loss at the IF of -0.3dB.

Attenuation at 200MHz is a modest -17.9dB. The analysis plots in Fig. 10 show that this very simple circuit achieves perfect impedance matching across the entire rf spectrum. These ideal results will not be achieved in practice because of the effects of component errors, drift and parasitics. High quality components should however provide results close to those shown in Fig. 10. The only disadvantages with this circuit are the slow frequency roll off and the mediocre attenuation of harmonics.

Weinburg diplexer

A better frequency response can be obtained using a third order diplexer shown in Fig. 11. Like the Weinreich-Carroll diplexer, the Weinburg diplexer has the ideal constant input impedance of 50+j0Ω at all frequencies, resulting in a very high return loss, Fig. 12. It also has a much better frequency response providing 33.8dB attenuation at 200MHz.

This circuit has been designed using the values¹⁰ in Table 2, with a centre frequency of 55MHz. The sharper roll off

means that a lower centre frequency can be used without an excessive insertion loss. At 37.5MHz, the insertion loss is 0.418dB.

Additional simulations were run to further define the performance of this diplexer. The graphs in Fig. 13 show a Monte-Carlo analysis based on a 10% component variation to determine how sensitive the circuit is to component errors. The upper graph plots variations in input impedance. The lower graph plots variations in return loss and frequency response.

These plots show that the return loss is very sensitive to

Fig. 11. Weinburg diplexer has improved frequency response relative to the Weinreich-Carroll diplexer.

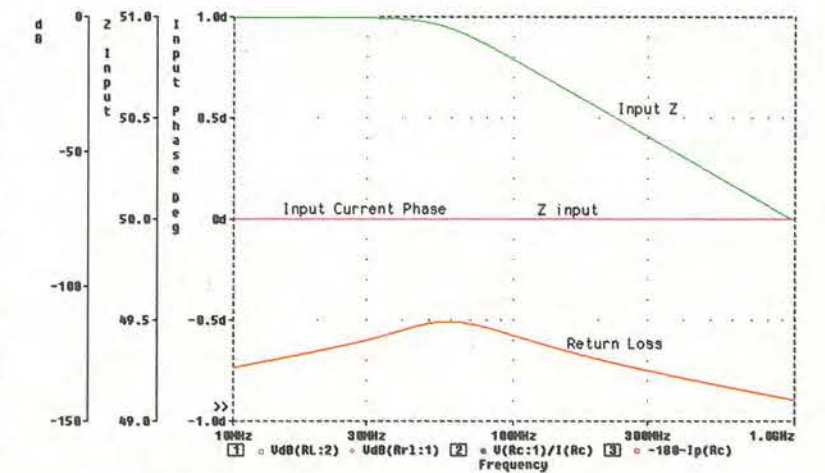
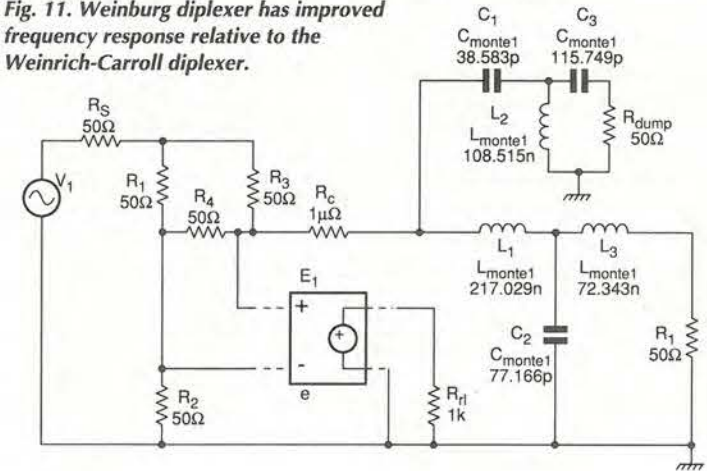

Fig. 12. Weinburg diplexer analysis. Sharper roll-off means that a lower centre frequency can be used without excessive insertion loss.

component errors varying over a range of about 90dB. At worst, the return loss is -24dB which remains within the required specification. Perfect results can only be achieved with perfect components.

Table 2. Weinburg diplexer normalised values.

Low pass	L_1	C_2	L_3
Third	3/2	4/3	1/2
High pass	$1/C_1$	$1/L_2$	$1/C_3$

Fig. 13. Weinburg Monte-Carlo analysis based on 10% component variation demonstrates the circuit's sensitivity to component errors. Upper plots are input impedance while lower are return loss and frequency response.

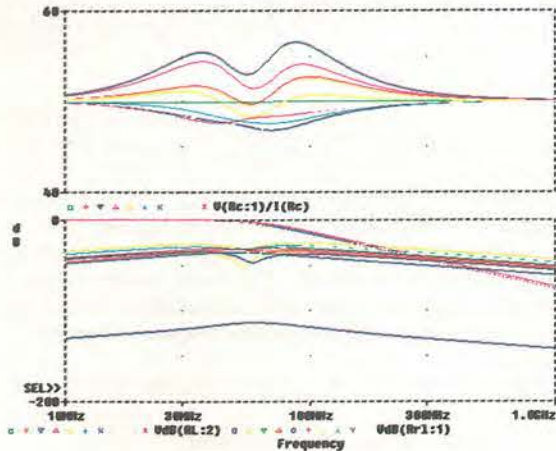

Fig. 14. Veltrop-Wilds diplexer offers good frequency response with near ideal input impedance.

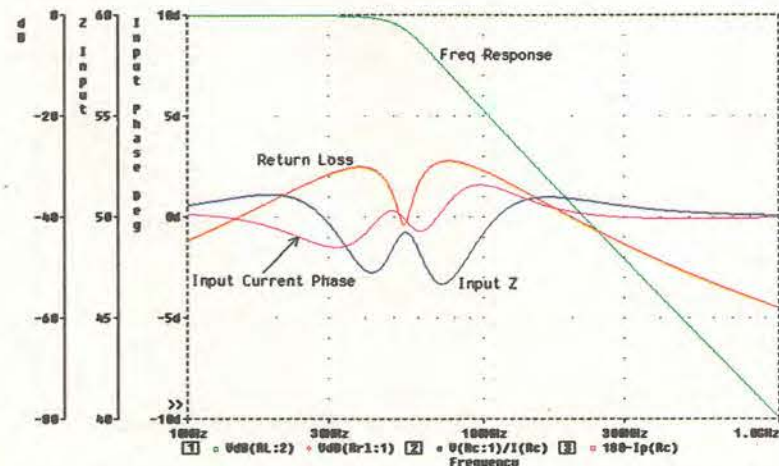
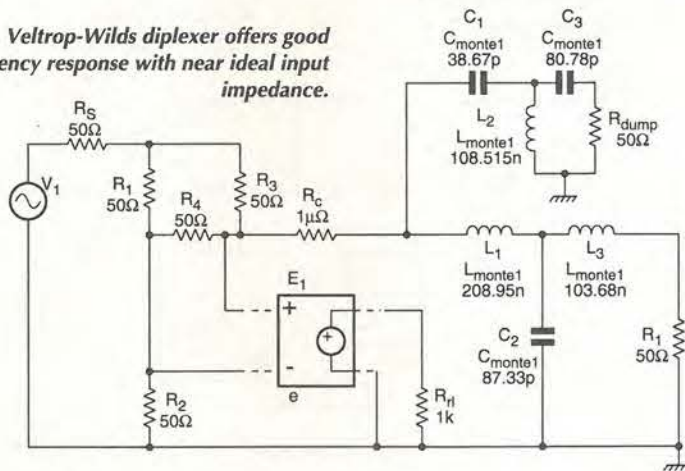

Fig. 15. Analysis of the Veltrop-Wilds diplexer reveals that input impedance varies between 46 and 54.8Ω.

Veltrop-Wilds diplexer

Diplexers based on modified Chebyshev filter tables offer good frequency response with near ideal input impedance. The diplexer shown in Fig. 14 is based on formula by Veltrop-Wilds². The circuit was calculated for a 3dB point of 55MHz which was selected to achieve an insertion loss of less than 0.25dB at the IF. This circuit yields the results shown in Fig. 15. Input impedance varies between 46Ω and 54.8Ω, which is not ideal, but entirely adequate. Return loss is at worst -25.3dB and improves at higher frequencies. The insertion loss at 37.5MHz is only -0.238dB while the attenuation at 200MHz is a respectable -39.7dB.

For applications requiring a steeper frequency roll off, the values for normalised 3rd, 5th and 7th order filters are shown in Table 3. Band-pass/stop diplexers may also be implemented with the values in Table 3 using the same techniques used to calculate component values with standard filter tables.

As before, a Monte-Carlo simulation based on a 10% component variation was run for the Veltrop-Wilds diplexer. The results of this analysis in Fig. 16 show the return loss is at worst -23.3dB which remains within the specifications and is only slightly lower than for the Monte-Carlo analysis of Weinburg diplexer.

Likewise, the input impedances for the two filters look similar. In real circuits with parasitics and component errors, there is unlikely to be any significant difference in measured return loss between a Weinburg or a Veltrop-Wilds diplexer.

Having determined that the input characteristics of the Veltrop-Wilds and the Weinburg in a real circuit are likely to be almost identical, a closer analysis of the output charac-

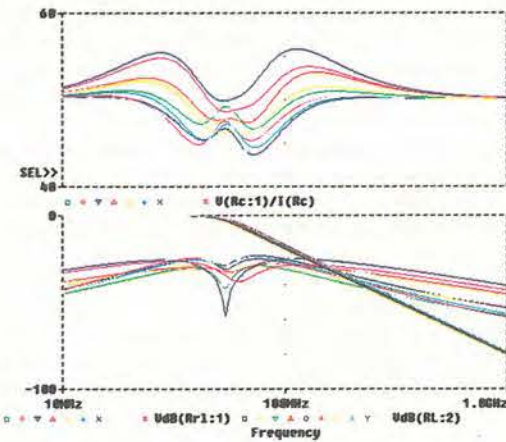

Fig. 16. Veltrop-Wilds Monte-Carlo analysis with 10% component variation show that return loss is at worst -23.3dB.

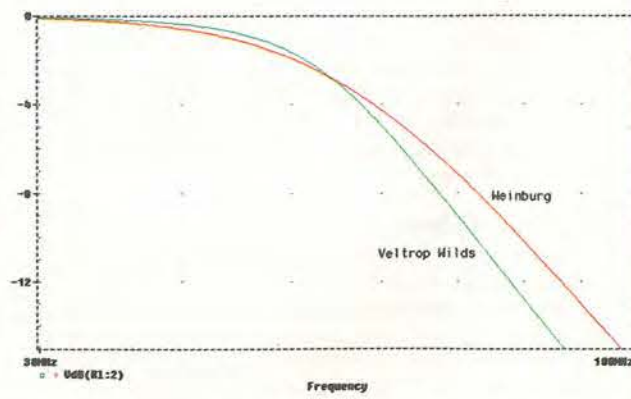

Fig. 17. Frequency-response comparison between the Veltrop-Wilds and Weinburg diplexers.

teristics was conducted. The results are plotted in Fig. 17 which shows a close in view of the frequency responses of both the Veltrop-Wilds and Weinburg diplexers.

You can see that the -3dB point for both diplexers occurs at 55MHz as expected. The Veltrop-Wilds diplexer has the advantage of a sharper roll off resulting in an additional -4.25dB attenuation at higher frequencies compared to the Weinburg diplexer. In addition, at the IF of 37.5MHz, the insertion loss differs by 40% in favour of the Veltrop-Wilds diplexer.

Analysis of the filter output characteristics shows that the Veltrop-Wilds diplexer has a small but significant advantage over the Weinburg diplexer.

Final selection

The Veltrop-Wilds diplexer circuit shown in Fig. 14 and selected for this application exceeds all specifications and comes close to the 'ideal' IF filter. It does not provide a perfect 50+j0Ω input impedance seen in the Weinreich-Carroll or the Weinburg diplexers, but it is close enough for practical purposes.

Compared with the Weinreich-Carroll or Weinburg diplexers, the Veltrop-Wilds diplexer has a better frequency response and there is the potential for further improvement by increasing the order of the filter. For this application, the Veltrop Wilds diplexer is considered to display the best overall characteristics.

Designing the Veltrop-Wilds diplexer

The design principle of the Veltrop-Wilds diplexer is to modify the values of standard Chebyshev low-pass filters in order to produce a diplexer with a constant input impedance. This is accomplished using the following general equations:

$$\epsilon = [(\text{antilog}(A_m/10)) - 1]$$

$$\omega'_{3dB} = \cosh(1/n \cdot \cosh^{-1} \sqrt{(1+2\epsilon)/\epsilon})$$

when n is even and,

$$\omega'_{3dB} = \cosh(1/n \cdot \cosh^{-1} \sqrt{(1/\epsilon)})$$

when n is odd, where A_m is the ripple value in dB and ω'_{3dB} is the modification factor. Full mathematical derivation can be found in reference 2.

The result is a modification factor ω'_{3dB} that is multiplied with each capacitor and inductor to obtain the modified low-pass table values. To obtain the modified element values for the high pass filter, each modified inductor is replaced with a capacitor equal to $1/C$ farads, and each modified capacitor is replaced with an inductor equal to $1/L$ henries. The 0.5 normalised conductance values for the high pass and low pass filters are now placed at the crossover frequency of $\omega=1$.

Tuning the filter

The results of the Monte-Carlo analysis indicate which variable should be used to 'tune' the filter. Frequency response does not vary greatly with component errors and is therefore unsuitable for tuning the filter.

Return loss is the most sensitive to component errors and varies by up to about 30dB in the analysis of both the Veltrop-Wilds and Weinburg diplexers. For optimum performance, a network analyser used to measure return loss will provide the most effective means of tuning the filter.

The next best alternative is use a grid-dip meter and capacitance meter. First, accurately measure and set the values of each capacitor allowing about 3pF for in circuit parasitics, then selectively fit inductors to form LC pairs. Using the grid-dip meter, each inductor is adjusted until the LC pair resonates at the correct frequency.

By fitting and removing components to create LC tuned circuits, the correct values can be set in circuit and the final

Table 3. Veltrop-Wilds diplexer normalised values for 0.1dB ripple.

Low pass	L_1	C_2	L_3	C_4	L_5	C_6	L_7
3rd	1.5133	1.509	0.7164				
5th	1.561	1.8069	1.7659	1.4173	0.6507		
7th	1.5748	1.8577	1.921	1.827	1.734	1.3786	0.6307
High pass	$1/C_1$	$1/L_2$	$1/C_3$	$1/L_4$	$1/C_5$	$1/L_6$	$1/C_7$
Input end							Output end

filter response should closely match the simulated results. When constructing these filters, every effort should be made to minimise both parasitics and component errors in order to obtain results like those shown in the simulations.

In summary

One of the important results of these simulations is that good performance does not necessarily require complex designs and high component counts.

The most complicated circuit analysed has six reactive components, while the simplest has just two. A wide range of results from the positively bad to nearly ideal were obtained from circuits that at a glance look remarkably similar.

The results graphically display the importance of selecting the right circuit for the right job. Design efficiency can be measured in terms of performance versus complexity. Complex designs are usually difficult to build and maintain. There are significant downstream advantages in ensuring that the most efficient design is used.

The above simulations show that some commonly used post diode mixer IF filters perform very poorly compared to the ideal IF filter. Performance can be improved using constant-impedance filters based on the Butterworth function but they are not recommended.

At all frequencies, the Weinreich-Carroll diplexer has a perfectly matched 50+j0Ω impedance, but its frequency response is only mediocre. The Weinburg diplexer also has a perfectly matched input impedance combined with a good frequency response. The best results are obtained using the Veltrop-Wilds diplexer which combines near ideal input matching with a superior frequency response.

Unlike the Weinreich-Carroll diplexer, the frequency response of the Veltrop-Wilds diplexer can be improved by using higher order variants.

The Veltrop-Wilds diplexer is recommended above all others for use with double balanced diode mixers.

References

- 'ARRL Handbook' 1995, page 15.23, Diplexer by Richard Weinreich and R.W. Carroll
- Veltrop, R.G. and Wilds, R.B., Modified Tables for the Design of Optimum Diplexers, *Microwave Journal*, June 1964.
- Reactive Loads - The Big Mixer Menace, P. Will, *Microwaves*, April 1971, pp 38-42
- 'Radio Receivers', W. Gosling, Peter Peregrinus Ltd 1996, ISBN:0-8634-056-1.
- 'Microwave Mixers', Stephen A. Maas, ARTECH House Inc 1993, ISBN 0-89006-605-1.
- Mini-Circuits RF/IF Designers Handbook
- Simultaneous insertion and return loss plots, C.J.Hall, *Electronics World and Wireless World*, May 1992, p 422.
- 'Microwave and RF Circuits: Analysis, Synthesis and Design', M.W. Medley, ARTECH House Inc 1993. ISBN:0-89006-46-2 p322.
- Distortion effects in a switching-diode modulator with tuned terminations. A.M. Yousif, J.G. Gardiner. *Proc IEE*, Vol 119, No.2, Feb 1972.
- Weinberg L., Additional Tables for Design of Optimum Ladder Network, Technical Memorandum 434, Hughes Aircraft Co., August 31 1956.

THE Autorouter for EASY-PC Pro' XM!

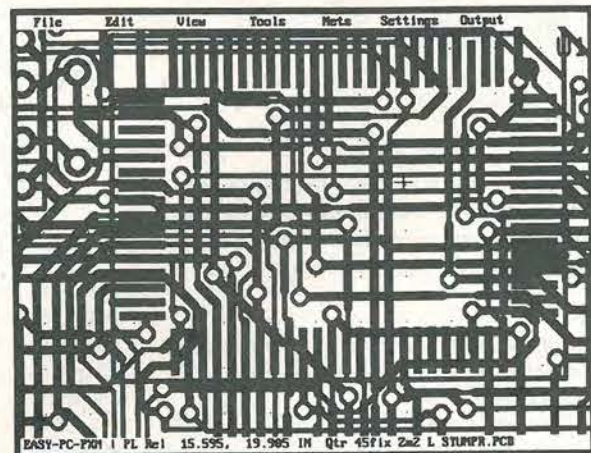

EE Product News "Products of the year" Award Winner (USA Magazine)

"The Best Autorouter that I have seen costing less than £10,000!" R.H. - (Willingham, UK)

- Uses the latest 32 Bit, Shape Based, Multi-pass, Shove-aside and Rip-up and Re-try Technology
- AutoRoute *very* large and complex boards
- User Controllable, User Configurable
- 100% Completion where other autorouters fail
- 100% Autorouted 140 Components on a 210mm x 150mm board in less than 10 minutes! (75MHz Pentium)
- Could Easily Pay For Itself On The First Project

MultiRouter - only £295/\$475!

Integrated Electronics CAD

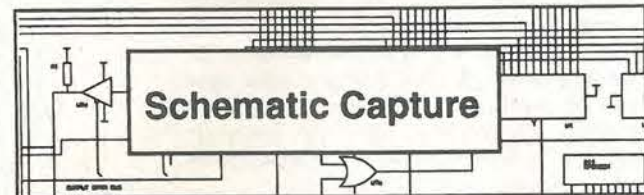

Schematic Capture



Analogue & Digital Simulation



And PCB Design

Prices from UK£75 / US\$145

Affordable Electronics CAD

EASY-PC Professional: Schematic Capture and PCB CAD. Links directly to ANALYSER III, LAYAN and PULSAR.	From \$275	£145
MultiRouter: 32bit Multi-pass Autorouter for EASY-PC Professional XM	\$475	£295
LAYAN: Electro-Magnetic Layout Simulator. Include board parasitics in your Analogue simulations. Links with and requires EASY-PC Professional XM and ANALYSER III Professional	\$950	£495
PULSAR: Digital Circuit Simulator	From \$195	£98
ANALYSER III: Analogue Linear Circuit Simulator	From \$195	£98
FILTECH: Active and Passive Filter Design program	From \$275	£145
STOCKIT: Comprehensive Stock control program for the small or medium sized business	From \$275	£145
EASY-PC: Award Winning PCB and Schematic CAD.	\$145	£75
Z-MATCH: Award Winning Smith-Chart based program for RF Engineers.	From \$275	£145

We operate a no penalty upgrade policy. US\$ prices include Post and Packing Sterling Prices exclude P&P and VAT.

For Full Information and Demo' Disk, please write, phone, email or fax:-

Number One Systems

UK/EEC: Ref: WW, Harding Way, St.Ives, Cambridgeshire, ENGLAND, PE17 4WR.
Telephone UK: 01480 461778 (7 lines) Fax: 01480 494042

USA: Ref: WW, 126 Smith Creek Drive, Los Gatos, CA 95030
Telephone/Fax: (408) 395-0249

- TECHNICAL SUPPORT FREE FOR LIFE
- PROGRAMS NOT COPY PROTECTED.
- SPECIAL PRICES FOR EDUCATION.

Email: sales@numberone.com
International +44 1480 461778

http://www.numberone.com



ada4pmu

LETTERS

Letters to "Electronics World"
Quadrant House, The Quadrant,
Sutton, Surrey, SM2 5AS

Overloaded

In Self's 'Overload matters' in the February '97 issue, Figs 1b and 1d omit the final downward break in the maximum level curve due to acceleration limits. This is significant because it shows the severe restriction in the possible high

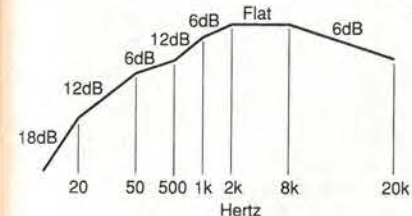

frequency level for the LP record. As an engineer I am proud that my preamp can handle 1V at 20kHz with 0.0008% thd, but I know it is meaningless in the real world. If a preamp can handle 100mV at 1kHz then it need handle only 80mV at 20kHz to have a uniform overload characteristic. (See figure above).

In the seventies, Tom Holman proposed the 'Holman test' for phono preamps - which now I'm sure he would rather us forget. It used a 1kHz square wave, band limited by a 6dB per octave rolloff at 30 or 100kHz, passed through an inverse RIAA. The output of the preamplifier was examined for even harmonics which are not present in a square wave.

A considerable furore ensued when many respected preamps failed the test. As we can see from Self's graph the rolloff should have been at 2kHz not 30 or 100, with an additional rolloff at 8kHz. A totally unrealistic test.

Back in the sixties, an engineer friend suggested to me that the RIAA curve should really level off at 10kHz instead of continuing downward. This is trivial to implement with the common topologies and would have reduced the number of burnt-out cutter heads with little noise penalty. That would have been a real world benefit unlike the misguided IEC 'amendment' - if you need a subsonic filter then use a steep one.

David Hadaway
Rindge
USA

Douglas replies:

This is essentially a matter of definition. The input impedances for

a floating voltage source are the same in the sense that a given voltage must cause the same current in each input. The voltages on them are far from equal, being indeed zero for the cold input - as described in detail in my article.

On mature reflection, it seems more sensible to say that a floating source can only have one meaningful input impedance, in this case between the hot and cold inputs. This is 20kΩ.

A measure of resistance

I was reading through the article 'Resistors in C' in the April edition, and was getting on fine until I came across "...it is advisable to use at least a 486DX... because of 57 600 calculations ... a lesser pc will take several minutes". Continuing the extrapolation, an old eight bit 2MHz processor running interpreted Basic would have taken around an hour - it didn't. So I thought something's wrong here and I started to look at the code listing.

It appears that each of the E24 values over ten decades is paired with every other value, to see if a match occurs within the required tolerance, using 57 600 (24x10x24x10) comparisons. The code tests each pair twice, the result for 1k and 12k will be the same as 12k and 1k so straight away the number of calculations could be halved to 28 800.

Further, it is rare to combine resistors where their ratio is greater than 1/(tolerance) so that for 1% components the limit would be 100:1. In the example given in the article 0.1% would equate to 1000:1, thus the search could be limited to a range of three decades instead of ten.

More fundamentally, all these calculations are repeated on each run generating exactly the same data; all that changes is that a different set of tests are applied. Therefore this data could be in a look up table, but it is still quite a large amount of data.

However, as resistor values are based on a decade structure once you have found the combinations to give 11.1R=12R/1.50R, the values for 11.1R follow simply as 120R/1.500R. So the look up table only needs to cover 1728 (24*1*24*3) entries.

If this table was arranged in numerical order only 12 comparisons

Q & A

Simulating crossover distortion

In answer to your query from Ian Hegglin, any good CAD package such as *Electronics Workbench*, can be used to simulate crossover distortion. The tricks are to use a low frequency to avoid masking with transit time effects, a low signal level and of course no negative feedback. To isolate and display the transfer hiatus characteristic on its own, sum the input signal to the output - suitably attenuated, of course - in a difference amplifier. This technique, which may be used to show most forms of distortion, was outlined by me in *Circuit Ideas* on page 608 of the July/August 1996 issue.

Reg Williamson
Whitehill
Staffordshire

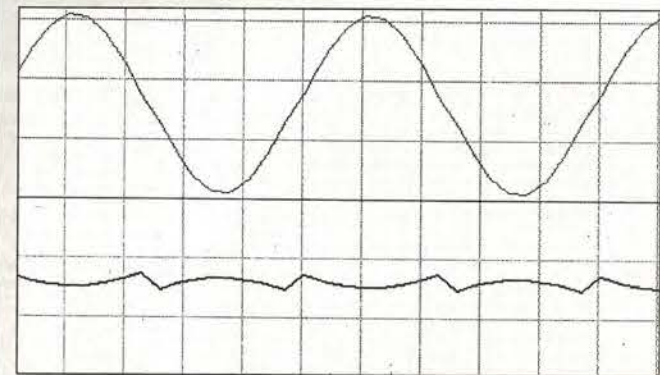

Instability problem

Cyril Bateman's letter about amplifiers going unstable with a piece of screened lead attached to their inputs brought back memories of this happening to amplifiers built or modified by me over the years.

I too cured this by means of a series resistor between the screened cable and the amp input terminals. My amplifiers used to oscillate at either rf, around 100kHz, or in the audio-frequency range. Efforts to discover the cause of this led nowhere.

Have any other readers experienced this? I'd love to know why it happens and how to fix it.
Charles Coultas
Wokingham

Bio-galvanic batteries?

Within some information supplied with a product called the 'Experimental printed circuit kit' - which is at least thirty years old - a 'Bacteria-powered radio' driven by a bio-galvanic battery appeared. The battery produced 2.5 to 3V, delivered around 5mA, and were said to be capable of running for a year or more on a few spoonfuls of sugar or a stale loaf of bread. Does this mean anything to anyone?

David Heaton
Wakefield
West Yorkshire

Before you ask, yes I have seen photocopies of the originals, and they do mention such cells - Ed.

would be needed to find the entry closest to any particular value - a reduction in run time calculations of 4800:1.

So I would recommend readers to resist the special offer on this

program, and have a go at coding it themselves in whatever language they choose.

David Markie
Ascot
Berkshire

KEIL SOFTWARE **hitex**

A Helping Hand From The C Professionals

166
51
251

Keil Professional C Developers Kits contain everything you require to get your microcontroller projects up and running fast!

- ▶ **C51, C16x, C251 C compilers with numerous microcontroller language extensions for the fastest, tightest code.**
- ▶ **HiSIM CPU and peripheral simulator**
- ▶ **HiTOP remote debugger**
- ▶ **RTX TINY real-time executive**
- ▶ **Comprehensive programming examples**

With our low cost emulator rental, training courses and hands-on user guides also available, you can be assured of meeting project release dates and budget targets everytime.

So let us give you a helping hand, ask for our comprehensive Keil information pack, including CD-ROMs!

Hitex (UK) Ltd. **E5**
 University of Warwick Science Park, Coventry, CV4 7EZ
 Tel: 01203 692066 Fax: 01203 692131
 Email:sales@hitex.co.uk Compuserve: 100646,1526

CIRCLE NO. 128 ON REPLY CARD

FROM AERIALS TO X-RAYS - EVERYONE NEEDS DIAL

Dial is the leading directory for all your electrical/electronics purchasing requirements - and it's FREE to qualifying applicants. How can you miss out any longer on the following...

- Access to over 11,000 electrical/electronics companies throughout the UK
- Easy product/service or company searches
- Trade Names Section - if you know the brand/trade name, now you can find the supplier
- Products and Services Showcase - the simple way to obtain in depth information about companies
- Faxback service for instant additional company information

To find out how to receive your FREE copy of Dial Electrical/Electronics or how to advertise within the directory, phone Judi Chapman on 0800 521393 quoting reference DEL6 or e-mail Judi on jchapman@reedinfo.co.uk

Dial Engineering is also available - contact Judi for more details

CIRCLE NO. 129 ON REPLY CARD

Halcyon Electronics Off-Air Frequency Products

We manufacture a range of Off-Air Frequency products including frequency standards, sources and disciplined standards including GPS, Customised units also available

Precision Frequency Source
 1kHz to 16MHz sinewave output, 0.0001Hz resolution, Easily settable via decade switches, VCXO backup as standard

Off-Air Frequency Standard
 1MHz, 5MHz and 10MHz, outputs, Options include Sinewave, Signal inhibit and Audio Warning

CIRCLE NO. 150 ON REPLY CARD

We are well known for our quality new and used test equipment. Our list is extensive, ranging through most disciplines. Call for details

CIRCLE NO. 151 ON REPLY CARD

Halcyon Electronics
 423 Kingston Road, Wimbledon Chase, London SW20 8JR
 Phone: 0181 542 6383 Fax: 0181 542 0340

CIRCLE NO. 130 ON REPLY CARD

ELECTRONICS WORLD **READER INFORMATION SERVICE**

For more information about any of the products or services in this issue of **ELECTRONICS WORLD**, simply ring the relevant enquiry number. Enquiry numbers may be found at the bottom of each individual advertisement.

101	102	103	104	105	106	107	108	109
110	111	112	113	114	115	116	117	118
119	120	121	122	123	124	125	126	127
128	129	130	131	132	133	134	135	136
137	138	139	140	141	142	143	144	145
146	147	148	149	150	151	152	153	154
155	156	157	158	159	160	161	162	163
164	165	166	167	168	169	170	171	172
173	174	175	176	177	178	179	180	181

Name _____

Job title _____

Company Address _____

Telephone _____ JUNE 1997

Only tick here if you do not wish to receive direct marketing promotions from other companies.

Newsagent order form

Pass this order form to your newsagent to ensure you don't miss the next issue of EW.

To
 (name of Newsagent)

Please reserve me the July issue of *Electronics World* - on sale 5th June - and continue to order every month's issue until further notice

Name.....
 Address.....

Thank you

Subscribe today!

Guarantee your own personal copy each month

Save on a 2 year subscription

ELECTRONICS WORLD
 INCORPORATING WIRELESS WORLD

Subscribe today!

Guarantee your own personal copy each month

Save on a 2 year subscription

ELECTRONICS WORLD
 INCORPORATING WIRELESS WORLD

Free circuit design demo disk with every order*

BACK ISSUES

Back issues of Electronics World are available, priced at £2.50 in the UK and £3.00 elsewhere, including postage. Please complete the coupon and send with correct payment to:
Electronics World, Quadrant House, The Quadrant, Sutton Surrey, SM2 5AS.
 Note that not all issues are available and please allow 21 days for delivery.



Postage will be paid by licensee

Do not affix postage stamps if posted in GI Britain, Channel Islands, N. Ireland or the Isle of Man.

Business Reply Service
 Licence No. CY711

ELECTRONICS WORLD
 Reader Information Service
 Reed Business Information
 Oakfield House
 Perrymount Road
 Haywards Heath
 Sussex RH16 3BR

21

SEE OVER!

ELECTRONICS WORLD

SUBSCRIPTION CARD

Please enter my subscription to ELECTRONICS.WORLD. I enclose Cheque/Eurocheque to the value of £_____ made payable to **Reed Business Information**. Please charge my Mastercard/Visa/Amex account

With £_____ Expiry Date _____

Signature _____

Name _____

Job Title _____

Address _____

Postcode _____

Tel: _____ Country _____

ELECTRONICS WORLD

SUBSCRIPTION CARD

Please enter my subscription to ELECTRONICS.WORLD. I enclose Cheque/Eurocheque to the value of £_____ made payable to **Reed Business Information**. Please charge my Mastercard/Visa/Amex account

With £_____ Expiry Date _____

Signature _____

Name _____

Job Title _____

Address _____

Postcode _____

Tel: _____ Country _____

SUBSCRIPTION RATES

UK 1 year £32
 UK 2 years £58
 Student rate(proof required) £21

Airmail

Europe 1 year £46
 Europe 2 years £83
 Rest of the world 1 year £56
 Rest of the world 2 years £101
 Surface mail 1 year £37

Post to:
ELECTRONICS WORLD
 P.O. Box 302
 Haywards Heath,
 West Sussex RH16 3DH UK.

CREDIT CARD HOTLINE
 Tel: +44 01444 445566
 Fax: +44 01444 445447

Please tick here if you do not wish to receive direct marketing-promotion from other companies

SUBSCRIPTION RATES

UK 1 year £32
 UK 2 years £58
 Student rate(proof required) £21

Airmail

Europe 1 year £46
 Europe 2 years £83
 Rest of the world 1 year £56
 Rest of the world 2 years £101
 Surface mail 1 year £37

Post to:
ELECTRONICS WORLD
 P.O. Box 302
 Haywards Heath,
 West Sussex RH16 3DH UK.

CREDIT CARD HOTLINE
 Tel: +44 01444 445566
 Fax: +44 01444 445447

Please tick here if you do not wish to receive direct marketing-promotion from other companies

Issue (Month/Year)	Quantity	Price	Total
Total Order			

Name _____
 Address _____

Post code _____

Method of payment (please circle): Access/Mastercard Visa Cheque PO

Cheques payable to Reed Business Publishing

Credit Card Number _____

Signed _____ Expiry Date _____

Do you have an original circuit idea for publication? We are giving £100 cash for the month's top design. Additional authors will receive £35 cash for each circuit idea published. We are looking for ingenuity in the use of modern components.

WIN A TTI PROGRAMMABLE BENCH MULTIMETER

"High accuracy, resolution and bandwidth - performance beyond the capability of hand-helds"



This high-performance bench multimeter could be yours in exchange for a good idea. Featuring a dual display, the 4.5-digit 1705 multimeter resolves down to 10µV, 10mΩ and 0.1µA and has a basic dc accuracy of 0.04%. Frequency measured is 10Hz to 120kHz with an accuracy of 0.01% and resolution to 0.01Hz. Capacitor and true rms measurements are also featured.

Recognising the importance of a good idea, Thurlby Thandar Instruments will be giving away one of these excellent instruments once every six months. This incentive is in addition to our monthly £100 'best circuit idea' award and £35 awards for each circuit published.

One-component oscillator

Using two components to make an oscillator¹ is, perhaps, a little over the top; you can use an op-amp and reduce the number of components by fifty percent. A CA3130 connected as shown in Fig. 1 with 7.5V oscillates at about 1.3MHz.

To complicate matters slightly, Fig. 2 is a voltage-controlled version, which varies in frequency

from 140kHz to 27MHz at the rate of 2MHz per volt when control voltage changes from 2V to 14V. Peak-to-peak output is roughly sinusoidal, amplitude being about 75% of the control voltage; the filter will improve the waveform and give a more constant level of about 1V pk-pk. If you use the other Schmitt inverters in the hex package to reduce output impedance, the

control voltage might need to be limited to avoid excessive dissipation.

P Gascoyne
Wantage
Oxfordshire

Reference

1. M F Abuelma'atti and S S Buhalm. *Electronics World*, July/August, p.615, 1996.

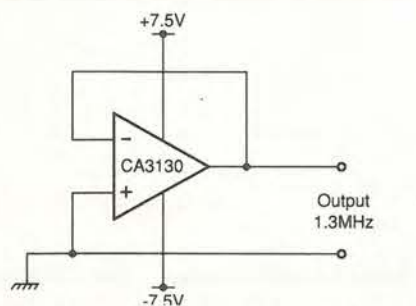

Fig. 1. They do not come simpler than this oscillator, if you ignore the components inside the op-amp.

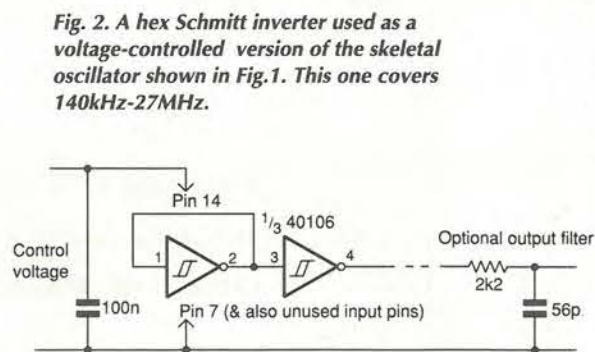

Fig. 2. A hex Schmitt inverter used as a voltage-controlled version of the skeletal oscillator shown in Fig.1. This one covers 140kHz-27MHz.

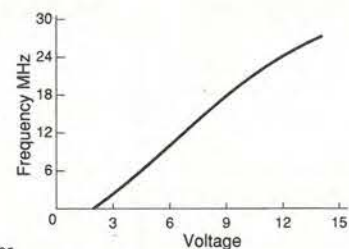

Fig. 2. Curve of frequency/control voltage for oscillator of Fig. 2.

Switch/latch/trigger

Switches from a 4066 cmos quad analogue switch are usable as inverters. When input to pin 13 in Fig. 1 is high, the switch is open and the output on pin 2 is low. In the reverse state, the channel is closed and the pull-up resistor holds the output high.

Two such switches form the latch trigger shown in Fig. 2. When the Q output is high, the channel of IC_{1(b)} is off, which causes the input of IC_{1(a)} to be high and its channel turned on, /Q being low.

V B Oleinik
Kaliningrad
Moscow

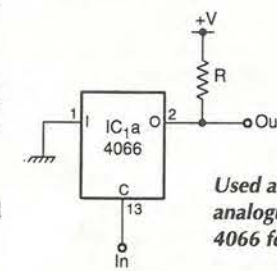

Used as inverters, analogue switches from a 4066 form a S-R latch.

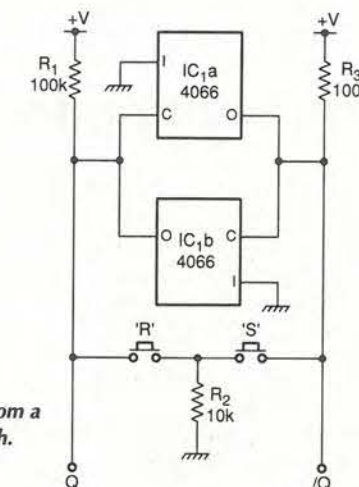

Interference-resistant infrared proximity detector

This retro-reflective, pulsed detector was intended as an obstacle detector for a small robotic vehicle. Its advantages over commercial types are its low power consumption, its resistance to interference from other ir sources and the fact that no optics are needed.

In the transmitter, a 555 timer generates current pulses of about 1µs duration at a frequency of 3kHz. The p-n-p BFY64 discharges the capacitor through the TIL38 infrared led at a peak current of 0.7A, which can be increased by either increasing Vcc or using a lower on-resistance transistor. To achieve a well-shaped current pulse, the type of capacitor used was a

Siemens B32650 pulse-resistant polypropylene 1000V type. A pulse with the same duration as the ir pulse is emitted from pin 3 and used as reference by the integrator.

The receiver is unusually simple. Diode bias enforces stage gain dependent on signal amplitude and polarity, the stages using alternate BC179 p-n-p and BC109 n-p-n types to allow for signal inversion; pulse shape is unimportant here, only its arrival time being of interest. Output pulse is of 1-2µs duration. No instability showed itself, but good layout and screening are needed to prevent feedback; in particular, the photodiodes must be screened from

the led. Improved performance is gained by the use of multiple photodiodes and by the use of a stop to confer the same field of view seen by the led.

In the integrator, pulses are converted to a dc level, the integrator being synchronised with the transmitter by the two-transistor gate and the reference signal from the transmitter. Improved resistance to interference is gained by applying a pseudo-random modulation to the transmitter by controlling the 555 reference at pin 5.

W Gray
Farnborough
Hampshire

£100 WINNER

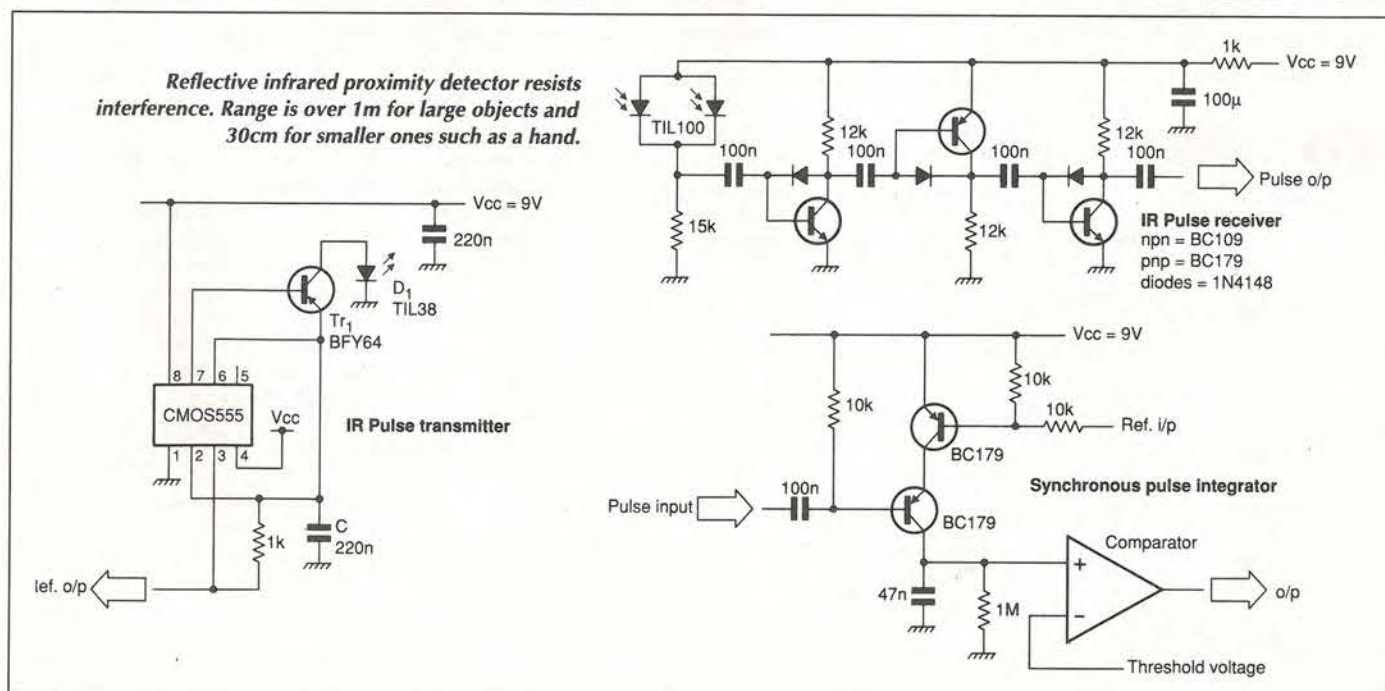

Reflective infrared proximity detector resists interference. Range is over 1m for large objects and 30cm for smaller ones such as a hand.

Two-wire remote control

Two wires control eight outputs, in this case to a dot/bar driver. The LM3915 supplies constant current to the switch/resistor chain at the remote end of the wires. Selecting one of the resistors by

means of a switch applies the voltage dropped across it to one of the driver outputs, the log. scale of the driver allowing fairly wide resistor tolerance. Since, according to the data sheet, LM3915s may be

cascaded, the number of remote resistors can be increased to suit other purposes. Alex Birkett London SE22

Eight outputs from the LM3915 bar driver are controllable remotely by the switches.

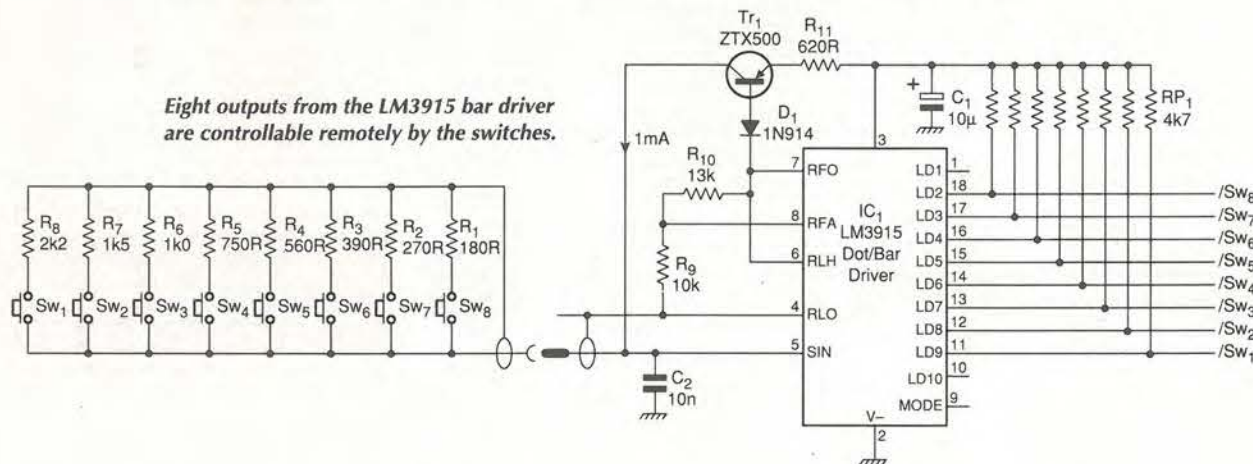

Offset source for op-amps

A separate source of offset voltage for a number of op-amps avoids the need to use the offset adjustment on some op-amps, which is intended for the op-amp's internal offset, not that from other parts of a system. Further, such procedures can adversely affect other characteristics such as offset drift and, in some cases where the gain from the offset terminals is high, cause trouble with noise pickup from inevitably longish connections to the adjustment pot. This one provides a stable source of offset voltage, independent of the power supply.

A band-gap reference, well decoupled, provides up to 5V, which is divided to reduce the effect of the LM611 offset and allow the 611 output to be only loosely coupled to the rest of the system by a largish resistor.

Since gain from the 611 non-inverting input is +2 and that from the inverting input -1, varying the potentiometer end to end varies the output between -5V and +5V. The two 1MΩ resistors ensure that, in the event of the wiper being open-circuit, the 611 output becomes zero rather than swinging to a supply rail.

Care with wiring is needed, particularly for ground connections.

Phil Dennis
University of Sydney
NSW
Australia

Offset-voltage source corrects for offsets caused by outside influences in a system using a number of op-amps, rather than those internal to op-amps.

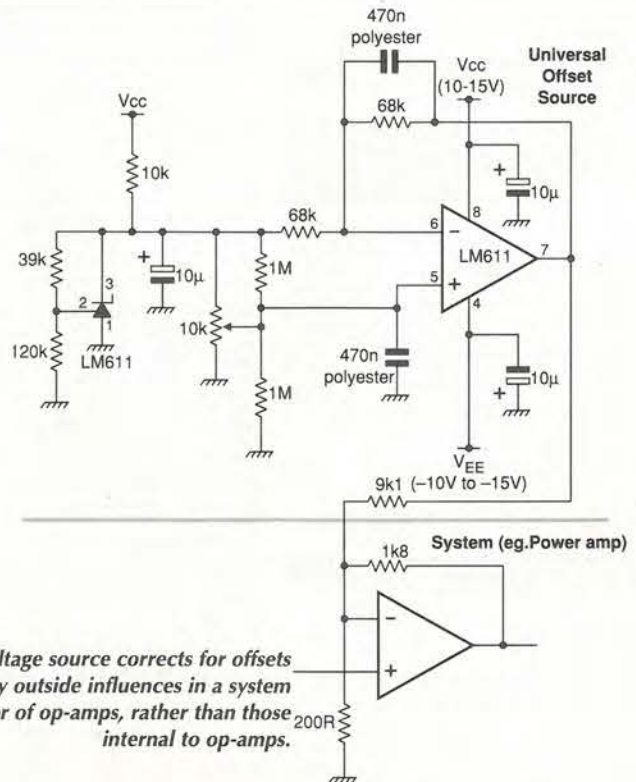

ANTRIM TRANSFORMERS LTD TOROIDAL TRANSFORMERS

- Large standard range from 15VA to 1kVA approved to EN60742 & AS3108
- Custom designs to most international standards from 10VA to 3kVA
- Rapid quotation, design and prototype service Any size production run catered for
- All transformers manufactured at UK factory allowing fast lead times at no extra cost
- 70V / 100V Line, valve output & low noise audio designs available
- Medical designs to IEC601/BS5724 & UL544

AGENTS / DISTRIBUTORS REQUIRED WORLDWIDE

Technical Sales Department, 30 Bramley Avenue

Canterbury, Kent, CT1 3XW, England

Tel: +44 (0)1227 450810 Fax: +44 (0)1227 764609

BRITISH MADE & BUILT TO LAST

CIRCLE NO. 132 ON REPLY CARD

YOUR Ideal Partner in UHF and VHF COMMUNICATION



One stop solutions for all your radio telemetry module needs.

When the success of your products depends on radio telemetry modules, you need a business partner you can trust. A skilled and experienced manufacturer that can offer modules of the highest quality, operating over a wide range of frequencies.

In other words, a partner like Wood & Douglas. Founded on technical excellence, Wood & Douglas is a British company that specialises in the design, development and production of radio-based products. With over 30 staff dedicated to meeting your requirements, the company is able to provide true one-stop purchasing - whatever your RTM needs.

All radio modules are highly functional, capable of meeting a wide range of requirements. Designed to offer efficient, easy-to-use radio telemetry components for system designers, they can open up a whole new world of product possibilities.

From portable bar-code readers to earthquake monitors, Wood & Douglas can help you make the most of the opportunities in radio telemetry.

To find out more about the possibilities, contact...



Lattice House, Baughurst, Tadley, Hampshire RG26 5LP, England
Telephone: 0118 981 1444 Fax: 0118 981 1567
email: info@woodanddouglas.co.uk
web site: http://www.woodanddouglas.co.uk

CIRCLE NO. 134 ON REPLY CARD

WE HAVE THE WIDEST CHOICE OF USED OSCILLOSCOPES IN THE COUNTRY

TEXTOR 7AS44S Dual Trace 100MHz DelayCursors	£1180
TEXTOR 744S 4Ch. 100MHz DelayCursors	£1180
PHILIPS PR2250 Dual Trace 350MHz Delay Cursors	£2360
I.P. 54200A Digitizing Oscilloscope 50MHz	£1800
TEXTOR 745 Dual Trace 350MHz Delay Sweep	£750
TEXTOR 747S Dual Trace 350MHz Delay Sweep	£580
TEXTOR 746S Dual Trace 100MHz Delay Sweep	£600
TEXTOR 721S Dual Trace 60MHz Delay Sweep	£450
PHILIPS 3055 2-1 Channel 50MHz Delay Sweep	£500
PHILIPS PR2217 Dual Trace 350MHz Delay Sweep	£480
8080L 051000 Osc Trade 30MHz	£200
8080L 05300 Dual Trace 200MHz (No handle)	£180
WITACH V209 Dual Trace 200MHz Main+Battery	£480
TEXTOR 7644 Dual Trace 100MHz Delay Dig Storage	£750
WITACH V6045 Dual Trace 100MHz Digital Storage	£1800
WITACH V6041 Dual Trace 40MHz Dig Storage	£650
WITACH V602 Dual Trace 200MHz Dig Storage Printer Output	£480
I.P. 1741A Dual Trace 100MHz Delay Analog Storage	£600
TEXTOR 746S Dual Trace 100MHz Delay Sweep Analog Storage	£450
TEXTOR 434 Dual Trace 50MHz Analog Storage	£250
LEADER LCD100 08M/Scope 200MHz Dig Storage LCD Display	£300

THIS IS JUST A SAMPLE. MANY OTHERS AVAILABLE

I.P. 8620C Sweep Osc with 8620B 2-18.6GHz	£2900
I.P. 8620C Sweep Osc with 8622B 0.01-2.4GHz	£2900
I.P. 8624A Gen Sig Gen 0.1-900MHz	£1750
WANDOR 2019 Synthesised AM/FM Sig Gen 800Hz-1040MHz	£1750
WANDOR 2022 AM/FM Sig Gen 100Hz-10Hz	£1800
WANDOR 2018A Synthesised AM/FM Sig Gen 800Hz-570MHz	£1500
I.P. 8614A AM/FM Sig Gen 500kHz-1024 MHz	£750
I.P. 8620C Sweep Pacillator Main Frame only	£750
FARWELL S6525 Synthesised AM/FM Sig Gen 10-520MHz	£480
FARWELL T1520 Transmitter Test Set	£600
WAVETEK 3000 AM/FM Sig Gen 1-300MHz Synthesised	£200
WANDOR 172015 AM/FM Sig Gen 10-320MHz	£250
I.P. 8614A UHF Signal Generator 1.8-5.5GHz	£300
I.P. 8614A UHF Signal Generator 800MHz-2.4GHz	£200
WANDOR 17231A Distortion Factor Meter 20Hz-20MHz 0.05% Un-used	£225
WANDOR 17933B Audio Power Meter	£350
RAS Video Noise Meter UP527 with UP527E 40Hz-100MHz	£1500
WILTON 6010A Programmable Sweep Gen 1-2GHz	£1500
I.P. 2350B Synthesised Low Gen 100-210MHz	£800
I.P. 8110A Programmable Pre Pulse Gen 50MHz	£1250
WANDOR 2305 Modulation Meter	£2250
PHILIPS PM5134 Sweep Fun Gen 0.001Hz-20MHz Sine/Sqr/Tri etc	£500
I.P. 5006 Signature Analyser	£150
I.P. 5004A Signature Analyser	£180
I.P. 8495H Attenuator DC-18GHz 0.7dB in 10dB steps	£350
I.P. 2351A Wave Analyser 100-300MHz LED Readout	£900
I.P. 8405A Vector Voltmeter 1-1000MHz from	£350
I.P. 8112A Programmable 50MHz Pulse Generator	£1
PHILIPS PM 5134 Sweep Func. Gen. 0.0001 Hz-20MHz Sine/Sqr/Tri/Pulse	£500
I.P. 5112A Func Gen 0.1Hz-10MHz AM/FM Sweep/Freq/Dir etc	£480
I.P. 8454H with 8494H Attenuators (Opt 001) and NP11713A Attenuator/Switch Drive	£1750
TEXTOR 740 Stereo Audio Monitor	£2750
QUARTZ Off Air Standard type 2A-01	£800
QUARTZ Series 808 Electric Power/Demand Analyser	£-
QUARTZ Universal Disturbance Analyser Series 826A	£-
800 Breakdown AC/DC and Insulation Tester R8015/2	£600
PHILIPS PM5119 Colour Pattern Generator	£600
PHILIPS PM 5500 Colour Pattern Generator	£250
I.P. 5432A Counter 24GHz-180Hz	£1750
I.P. 5340A Counters 10Hz-180Hz	£780

BUEL & KUGER EQUIPMENT AVAILABLE PLEASE ENQUIRE

SPECTRUM ANALYSERS	
I.P. 8554A 0.01-250MHz	£2000
ALTECH 727 0.001-500MHz	£2000
I.P. 853A with 8558B 100kHz-1500MHz	£2750
I.P. 182 with 8558B 100kHz-1500MHz	from £1800
WANDOR 17213 30Hz-110MHz	£1750
WANDOR 2170 with 18273 30Hz-1.25GHz	£1750
WANDOR 2382 100kHz-400MHz	£4000
I.P. 2582B Dual Channel 250Hz	from £2000

Many other POWER SUPPLIES AVAILABLE

Used Equipment - GUARANTEED. Manuals supplied if possible. This is a VERY SMALL SAMPLE OF STOCK. SAE or Telephone for lists. Please check availability before ordering. CARRIAGE all units £16. VAT to be added to Total of Goods and Carriage.

STEWART OF READING
110 WYKHAM ROAD, READING, BERKS. RG6 1PL
Telephone: (0118) 9268041. Fax: (0118) 9351696
Callers Welcome 9am-5.30pm Monday to Friday (other times by arrangement)

CIRCLE NO. 133 ON REPLY CARD

502

ELECTRONICS WORLD June 1997

June 1997 ELECTRONICS WORLD

503

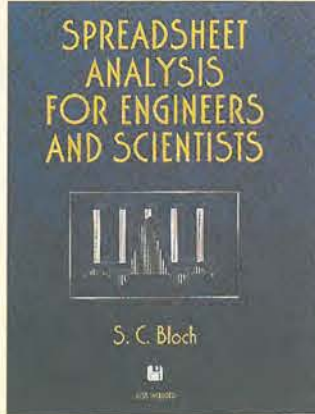

Spreadsheet Analysis for Engineers and Scientists

With this practical, hands-on guide, engineers and researchers learn, quickly and easily, the latest and most useful electronic spreadsheet methods. Using a variety of interactive techniques, including worksheets, self-test and practical programs on the included disk, *Spreadsheet Analysis for Engineers and Scientists* show you how to harness the power and versatility of spreadsheet programs, including those that contain the fast Fourier transform, complex operations and Bessel functions, and how to customise your own applications.

Includes disk
0471 126837, 336pp
UK £37.50, Europe £39.50, ROW £49.50

Electronic Component Reliability

Fundamentals, Modelling, Evaluation and Assurance
This text approaches the quality and reliability of electronic components from a unique standpoint. Traditionally the twin subjects of reliability physics and reliability statistics have been treated as separate entities. Here, the author examines both areas and reveals how components fail and how failures develop over a period of time.

0471 952966, 374pp
UK £50.50, Europe £53.50, ROW £66.50

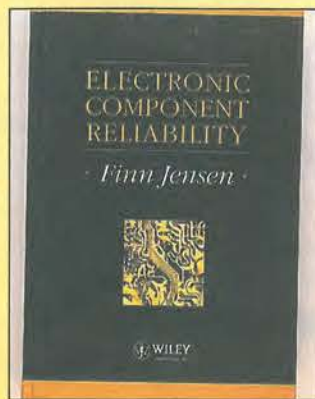

Fuzzy Logic

Implementations and Applications
Offering a new perspective on a growing field, this text explores the many hardware implications of fuzzy logic based circuits. As use of AI increases, so the VLSI area of circuits is becoming a growth subject. Opening with an overview of fuzzy sets and fuzzy logic the book moves on to cover a range of non-standard solutions for fuzzy logic VLSI circuits. Future trends, new concepts and ideas are all examined and supported with practical examples from the author's research.

ISBN 0471 950599, approx 346pp,
UK £50.50, Europe £53.50, ROW £66.50

Microelectronic Switched-Capacitor Filters

Switched-capacitor filters and associated MOS integrated circuits are now an established technology finding applications in the telecommunications and instrumentation fields. With unrivalled breadth of coverage, this book surveys the design techniques of an important class of analogue signal processing systems. An accompanying diskette containing a comprehensive computer-aided design package (ISICAP) enables readers to gain a greater depth of understanding of the described techniques. Containing both source code

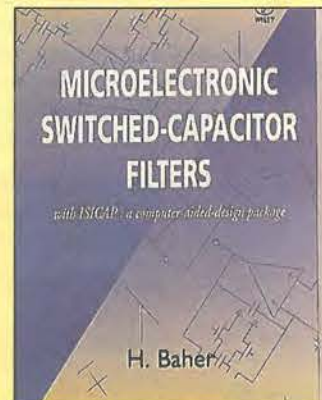

files and an executable version of the main design package, this alone will be an indispensable tool for many circuit designers.

Includes disk
0471 954047 384pp
UK £75.50, Europe £79.00, ROW £92.00

The I²C Bus

From theory to Practice
With a special emphasis on the I²C Bus, this guidebook through the world of micro controller-managed serial buses presents comprehensive coverage of the theory necessary to design the best possible communications bus for any particular application. The book examines typical industrial and consumer applications and enables the reader to design effectively in a real-world environment. A disk containing software for the I²C bus is also included.

Includes disk
0471 96268 6, 314pp
UK £54.50, Europe £56.50, ROW £65.00

High Frequency Analog Integrated Circuits

As one of the first textbooks to discuss integrated circuit design considerations and

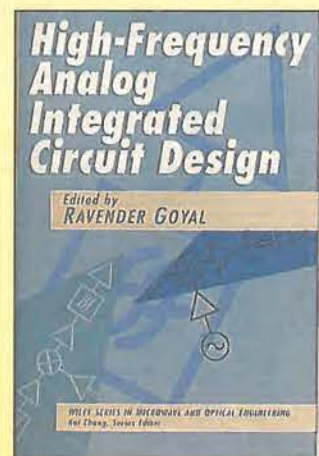

actual designs from the basic concepts, this title provides a solid background in designing basic circuits, advanced circuits and synthesis techniques.

0471 530433 424pp
UK £80.00, Europe £83.00, ROW £95.00

Speech Coding

A Computing Laboratory Textbook
This is one of the first lab manuals with software dedicated exclusively to speech processing and coding. It takes advantage of the development of the personal computer by making this technology accessible to a wider audience. The manual and Dos based software together create a user-friendly digital signal processing lab which allows the user to

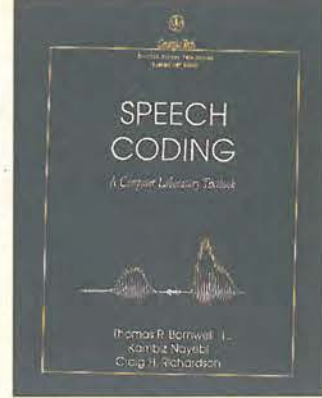

perform a wide variety of speech coding and speech processing experiments. The text presents and explains a set of basic speech coders analytically and in terms of the specific parameters controlling each coder. The manual leads the student through the experimental process of understanding how speech coders work and sound via over 70 exercises and projects. The class-tested menu-driven, Dos-based software can be operated by students with little or no training.

Includes disks
0471 516929, 194pp,
UK £28.95, Europe £30.95, ROW £36.95

Solar Cells and their Applications

The past decade has witnessed numerous important breakthroughs in solar cell technology, many of which have occurred in just the past few years. Far cheaper to produce and maintain, exhibiting a longer lifetime, and considerably more efficient than ever before, solar cells are, at last, in a position to compete with traditional technologies for both small and large-scale energy conversion applications. Including contributions from some of the world's leading experts in the field, this book reports the most important recent advances in solar cell technology. From in-depth discussions of breakthroughs in cell, module, and system technologies to a probing look at important environmental, health, and safety issues in the photovoltaic industry, it covers a broad range of topics of vital interest to solar cell researchers, power systems designers, and all those with professional interest in current and future capabilities of this important technology. Offers a detailed look at cutting-edge solar technology from an international team

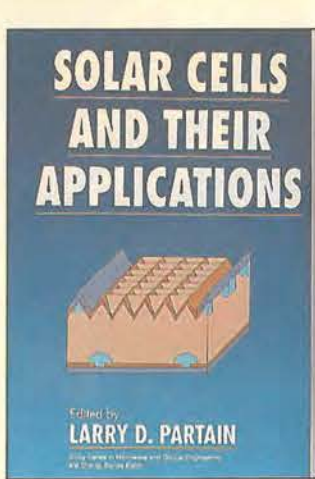

of researchers. Covers silicon, GaAs, InP, CdTe, a-Si:H, CuInSe₂ and GaSb solar cells, cells, concentrators, multijunction cell configurations, space cells, and more. Describes a wide range of applications - from space cells to terrestrial systems. Provides an informal look ahead at the future of solar cell technology.

0471 574201, 596pp,
UK £71.50, Europe £75.00, ROW £92.00

Introduction to High-Speed Electronics and Optoelectronics

Lasers, fibre optics, and high-speed optical systems share many concepts with microwave devices. Furthermore, semiconductor-based optoelectronics and microwave integrated circuits share evolving process technologies. It is only natural, therefore, that students of optoelectronics be introduced to high-speed concepts in a unified manner. This highly practical intensive introduction enables electrical engineers, applied physicists, and students to develop and identify tools for understanding, analysis, design, and characterisation of high speed components. Broad in scope, this unique

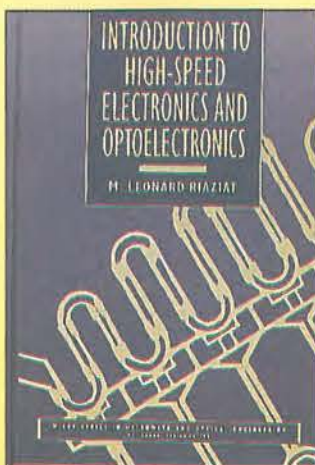

text/reference examines the complementary nature of electronics and optics and emphasizes high-speed technology in which the two fields are less differentiated. Beginning with an overview that develops a perspective and appreciation of analog high-speed technology in general, the book goes on to cover devices and circuits used at microwave and millimeter-wave frequencies, optical components, and optoelectronic integrated circuits and subsystems. Particular attention is paid to applications in the area of high levels of interest in this area and because many of the concepts are applicable in other fields. The book concludes with important coverage of the often-overlooked area of measurement and characterization of high-speed devices. Fully referenced and supplemented with hundreds of helpful illustrations, *Introduction to High-Speed Electronics and Optoelectronics* is equally useful as a professional reference or a textbook for senior undergraduate and first-year graduate courses.

0471 015822, 312pp,
UK £65.00, Europe £67.00, ROW £77.00

Risc Systems and Applications

Professor Daniel Tabak has completely revised and updated his two previous books on Reduced Instruction Set Computer architecture to produce this new book, RISC Systems and Applications. The text is a unique, concentrated, detailed description of the architecture and implementation of most recent high-performance RISC systems, such as DEC Alpha AXP21164, IBM/Motorola/Apple PowerPC 620, Sun Microsystems and Texas Instruments UltraSPARC and SuperSPARC, MIPS technologies R10000, Intel i860 XP, Motorola MC88110, Hewlett-Packard PA-7100/8000 and the transputer. It also includes details of pioneering devices such as Berkley's RISC II and Stanford's MIPS and multiprocessor, real-time and workstation systems.

ISBN 0863 801889, 452pp,
UK £50.50, Europe £54.00, ROW £67.00

All prices are fully inclusive of packing and delivery

Return to Jackie Lowe, Room L333, Quadrant House, The Quadrant, Sutton, Surrey, SM2 5AS

Please supply the following titles:

Qty	Title or ISBN	Price

** All prices on these pages include delivery and package **

Total _____

Name _____

Address _____

Postcode _____ Telephone _____

Method of payment (please circle)

Access/Mastercard/Visa/Cheque/PO

Cheques should be made payable to Reed Business Publishing

Credit card no. _____

Card expiry date _____

Signed _____

Please allow up to 28 days for delivery

PROTEUS

For DOS and Windows 3.1, 95 & NT

The Complete Electronics Design System - Now With RIP-UP & RETRY!

NEW LOW PRICE OPTIONS AVAILABLE
 Level 1 (500 pins) from £250
 Level 2 (1000 pins) from £495
 Level 3 (unlimited) from £995

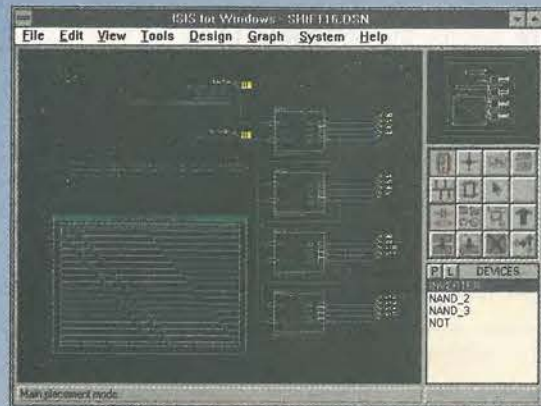

Schematic Capture

- Easy to Use Graphical Interface under both DOS and Windows.
- Netlist, Parts List & ERC reports.
- Hierarchical Design.
- Extensive component/model libraries.
- Advanced Property Management.
- Seamless integration with simulation and

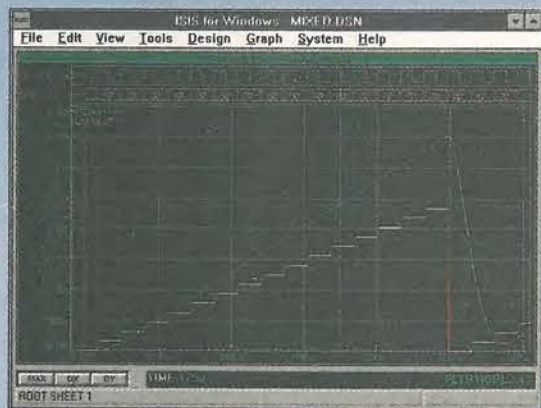

Simulation

- Non-Linear & Linear Analogue Simulation.
- Event driven Digital Simulation with modelling language.
- Partitioned simulation of large designs with multiple analogue & digital sections.
- Graphs displayed directly on the schematic.

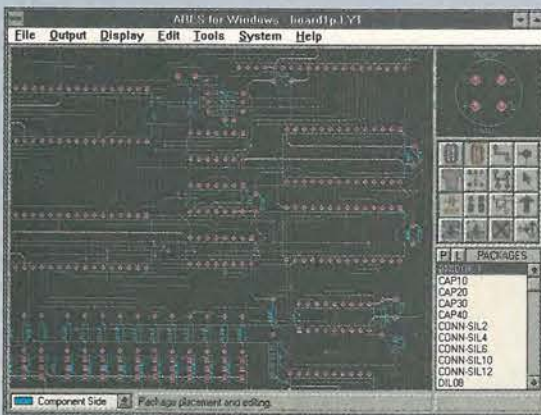

PCB Design

- 32 bit high resolution database.
- Multi-Layer and SMT support.
- Full DRC and Connectivity Checking.
- RIP-UP & RETRY Autorouter.
- Shape based gridless power planes.
- Output to printers, plotters, Postscript, Gerber, DXF and clipboard.
- Gerber and DXF Import capability.

labcenter
Electronics

Call now for your free demo disk or ask about the full evaluation kit.
 Tel: 01756 753440. Fax: 01756 752857.
 53-55 Main St, Grassington. BD23 5AA.

Fully interactive demo versions available for download from our WWW site. Call for educational, multi-user and dealer pricing - new dealers always wanted. Prices exclude VAT and delivery. All manufacturer's trademarks acknowledged.

EMAIL: info@labcenter.co.uk
 WWW: <http://www.labcenter.co.uk>

CIRCLE NO. 135 ON REPLY CARD

Ray Fautley shows how to design reliable voltage doubling power supply circuits with the aid of look-up tables.

Voltage doubling

The symmetrical voltage doubler, shown in the diagram, is useful for providing high voltages at low currents.

The term 'symmetrical' is used as the diodes and capacitors are connected in a symmetrical fashion, looking rather like the bridge-rectifier circuit. There is no direct connection between the alternating input and the dc output. (Another type of voltage doubler circuit is the common-terminal circuit where the ac supply and dc output have a common terminal, and so is not 'symmetrical'.)

Alternating voltage is applied to the two rectifier diodes D_1 and D_2 . When point x is positive, diode D_1 conducts but D_2 is cut off. Current through D_1 charges capacitor C_A to approximately the peak of the transformer secondary voltage. During the next half cycle point x will be negative with diode D_2 conducting and D_1 cut off.

Current through D_2 charges capacitor C_B , again to approximately the secondary peak voltage.

As the two capacitors C_A and C_B are connected in series, so are the voltages across each of them. The two voltages - being of suitable polarity - add, providing nearly twice the output voltage of a single diode half wave rectifier. This is logical because the voltage doubler is really just two half wave rectifiers in series.

Source resistance is shown as resistor R_s .

Voltage doubler design procedure

The procedure for designing the symmetrical voltage doubler is similar to that used for the rectifier circuits described in my previous articles.

- 1) Specify required dc output voltage at full load $E_{dc(load)}$ in volts.
- 2) Specify required maximum load current

$I_{dc(load)}$ in amps.

- 3) Specify maximum ripple voltage acceptable, $V_{r(rms)}$ in volts.
- 4) Specify the ac mains supply voltage $V_{pri(rms)}$ in volts.
- 5) Specify frequency of the mains supply f in hertz.
- 6) Determine the value of equivalent load resistance R_L ,

$$R_L = \frac{E_{dc}}{I_{dc(load)}}$$

where E_{dc} is the design value of the dc output voltage. It is the required voltage across the load $E_{dc(load)}$, added to any voltage drop across the diodes.

As this type of rectifier is mostly used for obtaining a high voltage at low current the diode voltage drop can be ignored, so,

$$R_L = \frac{E_{dc(load)}}{I_{dc(load)}}$$

- 7) Determine the average current I_o through each diode:
 $I_o = I_{dc(load)}$
- 8) Determine a value for the source resistance of the supply R_s . As only high resistance loads - i.e. high voltage and low current - are to be considered, the predominant resistance will be that of the transformer windings. So,

$$R_s = R_{sec} + \frac{R_{pri}}{N^2}$$

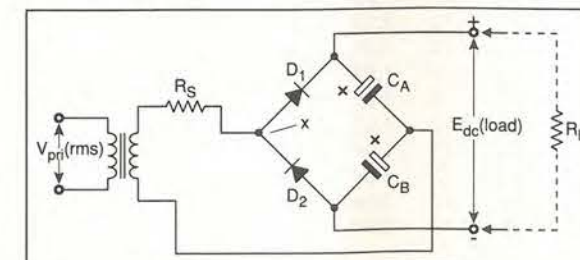

Used for providing high voltages at low current, this circuit produces nearly twice the voltage of a single-diode half-wave rectifier.

However, as it's likely that the transformer winding resistance are not known, assume R_s is about 2% of R_L . So,

$$R_s = R_L \times \frac{2}{100}$$

- 9) Calculate the ratio of R_s to R_L as a percentage,
 $\frac{R_s}{R_L} \times 100\%$
- 10) Determine the percentage ripple voltage from the specified maximum ripple and dc output voltage:

$$V_r \% = \frac{V_{r(rms)}}{E_{dc(load)}} \times 100\%$$

- 11) From the Table 1, determine the value of X required to provide the percentage ripple voltage $V_r\%$ in step (10) above, for $(R_s/R_L)\%$ calculated in step (9).

- 12) Calculate the value of capacitors C_A and C_B in the circuit diagram.

$$C_A = C_B = C = \frac{X(10^6)}{2\pi f R_L} \mu F$$

- 13) Find the nearest standard, or available, value for C_A and C_B , close to, or just above, the value calculated in step (12). If the practical value of C is different from that in step (12), call it C_1 and determine a new value for X (call it X_1) from, $X_1 = 2\pi f C_1 R_L$, or with C in microfarads,

$$X_1 = \frac{2\pi f C_1 R_L}{10^6}$$

- 14) From the figures in Table 2, determine the value of Y for X in step (11), or X_1 in step (13), and $(R_s/R_L)\%$ in step (9).

- 15) Determine the transformer secondary voltage $V_{sec(rms)}$ required, from the value for Y in step (14),

$$V_{sec(rms)} = \frac{E_{dc(load)}}{\sqrt{2} \times Y}$$

$$= \frac{0.707 \times E_{dc(load)}}{Y}$$

$$24) I_{t(rms)} = \sqrt{2} \times I_{rms} = \sqrt{2} \times 0.246 = 0.348A, \text{ or } 348mA$$

$$25) T_{VA} = V_{sec(rms)} \times I_{t(rms)} = 453 \times 0.348 = 158VA$$

26) Mains transformer ratings required,

T_{VA}	volt/ampere rating	158VA
$V_{pri(rms)}$	primary winding	240V
$V_{sec(rms)}$	secondary winding	453V
$I_{t(rms)}$	secondary current	348mA

I hope that the four simple procedures for designing the four key types of rectifier circuits that I have described over the past few months will prove as useful to you as they have to me over the years. ■

Designing reliable rectifiers

Ray Fautley has produced three earlier articles along similar lines to this one, covering:

- Full-wave bridge rectifier
September 1996 issue, p. 691
- Half-wave rectifiers
December 1996 issue, p. 980
- Full-wave rectifier with centre tap
February 1997 issue, p. 133

Luxuriant editing! SpiceAge interfaces smoothly to almost any PCB design suite.

Although we would like you to use our own excellent Geswin schematic capture program which is purpose built for SpiceAge, if you already have a schematic program, there is a good chance that **SpiceAge** will work with it better than any other circuit simulator.

When you iterate between a schematic and a SPICE-like simulation environment while refining your circuits, the simulation settings and precious details such as polynomial functions on components can be lost. So without Geswin, it was sometimes easier to write the simulation netlist directly. However, SpiceAge's **circuit update** button only affects *changes* in the circuit built by the schematic and, because it retains all the previous information, you can spontaneously iterate between schematic and circuit.

To hear more about this and other nice touches in SpiceAge, please contact:

Those Engineers Ltd, 31 Birkbeck Road, LONDON NW7 4BP.

Tel 0181 906 0155 FAX 0181 906 0969 Email 100550.2455@compuserve.com

Table 4. To Find the value for W.
0.5X (R_g/0.5R_L)%

	0.02	0.05	0.1	0.2	0.5	1.0	2	5	10	30	100
1	3.70	3.70	3.70	3.64	3.62	3.60	3.60	3.59	3.58	3.57	3.46
2	4.60	4.57	4.55	4.53	4.52	4.50	4.28	4.20	4.08	3.72	3.51
3	5.50	5.40	5.33	5.30	5.20	5.10	5.00	4.67	4.33	4.00	3.55
4	6.20	6.17	6.13	6.10	6.00	5.98	5.45	5.20	4.95	4.05	3.57
5	7.30	6.95	6.90	6.85	6.80	6.75	6.51	5.60	5.00	4.10	3.62
6	8.00	7.90	7.70	7.60	7.50	7.30	6.90	5.84	5.09	4.19	3.63
7	8.70	8.55	8.50	8.30	8.10	7.82	7.30	6.00	5.10	4.22	3.64
8	9.60	9.50	9.35	9.00	8.50	8.20	7.69	6.15	5.14	4.23	3.64
9	10.3	9.80	9.60	9.50	9.10	8.55	7.72	6.23	5.21	4.25	3.65
10	10.9	10.7	10.5	10.1	9.50	8.64	7.74	6.30	5.28	4.26	3.66
20	16.0	15.0	14.4	13.0	11.1	9.44	7.83	6.47	5.29	4.27	3.66
30	19.7	18.0	16.3	14.3	11.7	9.60	7.92	6.50	5.31	4.27	3.66
40	21.9	20.0	17.3	14.7	12.1	9.64	8.01	6.51	5.33	4.28	3.66
50	23.7	20.8	18.2	15.2	12.2	9.70	8.10	6.51	5.34	4.28	3.66
60	24.9	21.1	18.5	15.4	12.3	9.77	8.12	6.51	5.34	4.29	3.66
70	25.9	21.4	18.9	15.6	12.4	9.84	8.14	6.51	5.34	4.29	3.66
80	26.7	21.8	19.4	15.7	12.4	9.90	8.16	6.51	5.34	4.30	3.66
90	27.5	22.2	19.5	15.8	12.5	9.93	8.18	6.51	5.34	4.30	3.66
100	28.5	22.5	19.7	15.9	12.5	9.96	8.19	6.52	5.35	4.31	3.66
200	30.5	23.0	20.0	16.3	12.6	10.0	8.19	6.52	5.36	4.31	3.67
300	31.6	23.3	20.5	16.9	12.7	10.0	8.20	6.53	5.38	4.32	3.67
400	32.8	23.5	20.9	17.0	12.7	10.0	8.20	6.54	5.40	4.32	3.67
500	33.3	23.8	21.0	17.1	12.8	10.0	8.20	6.55	5.42	4.33	3.68
600	33.8	24.0	21.1	17.2	12.8	10.1	8.20	6.56	5.44	4.33	3.68
700	34.2	24.5	21.2	17.3	12.9	10.1	8.20	6.57	5.46	4.33	3.69
800	34.4	24.9	21.4	17.4	12.9	10.1	8.20	6.58	5.48	4.33	3.69
900	34.5	25.8	21.5	17.5	13.0	10.1	8.20	6.59	5.52	4.33	3.70
1000	34.7	27.0	21.6	17.6	13.0	10.1	8.20	6.60	5.56	4.33	3.70

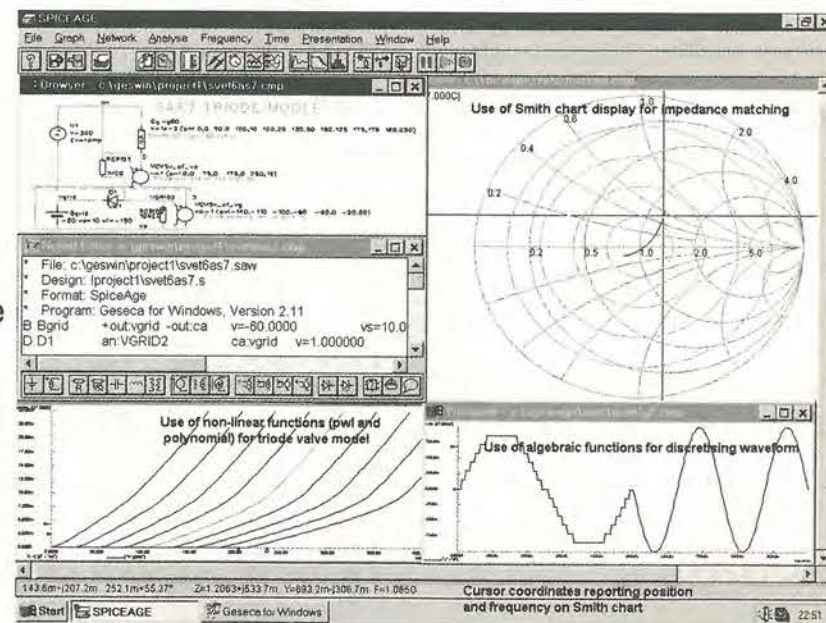

NEW PRODUCTS CLASSIFIED

Please quote "Electronics World" when seeking further information

ACTIVE

Arrays

High-I/V darlington. Arrays of seven and eight darlington driver transistors by FET Electronics interface between logic-level circuitry and power loads such as relays, print hammers and displays. *FE ULN2001-24* (seven drivers) and *FE ULN2801-2824* (eight) take up to 500mA through each driver, outputs being paralleled for more, and all have open-collector output and clamp diodes. Voltage rating is 50V or 95V, depending on type. Various input characteristics cope with pmos, comos and cmos input. FET Electronics Ltd, Tel., 01635 524490; fax, 01635 552244.

A-to-d and d-to-a converters

Fast a-to-d converters. Philips intends its *TDA8762A* and *TDA8763A* high-speed, high-accuracy and low-power converters for use in broadcast quality cameras, communications and medical imaging. Both provide 10-bit resolution at 80Msamples/s and 50Msamples/s respectively, the 8762 giving a t_l output and the 8763 cmos output from 2.7V to 5.25V. When sampling at 40Msamples/s, the 8763 achieves an effective bit length of 9.4bit, s/n of 58dB and thd of -68dB, the 8762 at 80Msamples/s being similar but with an effective bit length of 9.3bit. Sample-and-hold circuitry is not needed and low input capacitance avoids the need for buffering. Gothic Crellon Ltd, Tel., 01734 788878; fax, 01734 776095.

Transmission d-to-a. Analog Devices' *AD976x* family of cmos d-to-a converters is meant for use in the transmission path of communications and signal-generation equipment, all members providing differential 20mA output current and sharing a common 28-pin SOIC package. The 125Msamples/s family consists of the 8-bit 9708, 10-bit 9760, 12-bit 9762 and 14-bit 9764, plus the 50Msamples/s, 10-bit 9760-50. All run from a 2.7-5.5V single supply on 45mW (3V) with a power-down mode on 25mW. Performance features include a spurious-free dynamic range over the Nyquist band from 53dB when clocked at 100Msamples/s to 79dB at 50Msamples/s. Total harmonic distortion of the 9752 clocked at

25Msamples/s with a 1MHz output is -78dB. Analog Devices Ltd, Tel., 01932 266000; fax, 01932 247401.

Logic

Electronic tagging. Holtek *HT6P20* electronic serial number chips offer 2²⁴ combinations and are intended for use in wireless key fobs, access control and burglar alarms. They are available programmed or blank and in five styles: the *HT6P20* outputs its code on power-up; *6P20B* allows the last two digits to be set by the user to identify the type of sensor or area from which the code was transmitted; and *HT6P20D/E* allow the last four and eight bits to be set. Supplies down to 2V will power the devices. With a Holtek 48000 8-bit microcontroller, a low-power tagging system can be made for under £1. Flint Distribution, Tel., 01530 510333; fax, 01530 510275.

Optical devices

Multiple leds. Dialight's range of led arrays now includes the *553 Series*, a dual, six-position type previously to special order and now standard. It replaces six bi-level devices or 12 separate ones, removing the need to bend 24 leads and giving accurate alignment. The leds have integral resistors for 5V, draw 2mA and are available in two-colour types. Viewing angle is 30°. Dialight, Tel., 01223 424313; fax, 01223 423493.

PASSIVE

Passive components

Miniature coils. Three new miniature wire-wound coils in the 1008 package from Toko, the *FSLU2520 Series* offer inductances from 0.01µH to 220µH in E12 values, low resistance, typical Q of 45 and 750ppm/°C temperature coefficient. Coils are in a sealed, heat-resistant case for flow or reflow soldering. Cirkit Distribution Ltd, Tel., 01992 444111; fax, 01992 464457.

Thick-film resistors. Virtually non-inductive thick-film power resistors from RS Components are made by two suppliers: Vishay-Sfernice make the 5-50W types, while the 100W and 250W resistors come from Meggitt CGS. Cermet thick-film techniques are used, the housing being hard epoxy, and the components are meant to be mounted on a heat sink. The V-S resistors are to ±5% tolerance and

work in temperatures from -55°C to 125°C, the Meggitt CGS ones having a ±10% tolerance and -55°C to 70°C temperature range. All types will withstand a short-term overload. RS Components Ltd, Tel., 01536 201234; fax, 01536 405678.

Wirewound, switched pots. BFI Ibexsa offers a range of 24mm diameter, single-turn wirewound potentiometers with a 4W rating and values in the 10Ω-22kΩ band. Switches are two-pole changeover types rated at 240V ac, 4A and 12V dc, 10A. Spindles are supplied to customers' specification, in either metric or imperial sizes. BFI Ibexsa Electronics Ltd, Tel., 01622 882467; fax, 01622 882469.

Audio products

Comprehensive sound processor. Mitsubishi announces the *M62460FP* sound processor which forms a single-chip providing Dolby Pro Logic surround sound including centre and surround sound channel trimming for five speaker systems. It is an analogue processor with Pro Logic decoder, on-board memory and the I²C bus for closed-circuit television. A microprocessor interface renders the device simple to use, facilities including disco, hall, live mode and five delay time positions for digital space surround effects and 147.5ms or 196.6ms echoes. The use of BiCMOS is said to provide improved performance over cmos devices, as does the analogue design over combined analogue-digital types. Mitsubishi Electric UK Ltd, Tel., 01707 276100; fax, 01707 278837.

Communications equipment

Comms boards. *C320* from Amplicon Liveline is an intelligent communications system providing between eight and 32 RS232 or RS422 serial comms ports for any pc having a free ISA slot. Each contains a plug-in controller board for the pc, a cpu module which is mountable up to 100m from the pc and a uart to plug into the cpu module to give eight serial channels, each cpu taking up to four uarts for 32 channels and each pc holding four controller boards to give a total of 128 ports. Controller and cpu both have 46MHz risc processors and RS422 interfaces which, with the 512K of dual-ported ram in the controller, relieves the host of processing overhead. Software supplied is configuration and driver



Microwave components

L-band GaAs fets. Over the 1.6GHz to 2GHz, Toshiba's *TPM1919-40* GaAs fets deliver an output power of 42.7W or 46.33dBm, with a gain of 13.3dB and 42% power added efficiency; saturated power output is 51.3W. This is said to be the highest power at 1.8GHz ever achieved by a GaAs fet. gain flatness is ±0.5dB. Steatite Microelectronics Ltd, Tel., 0121 643 6333; fax, 0121 643 2011

software for Windows3.x, NT, 95, dos, SCO Unix, SCO Xenix, Unix SVR3.x, Unix SVR4.2, UnixWare and Solaris x86. Amplicon Liveline Ltd, Tel., 0800 525 335 (free); fax, 01273 570215.

Connectors and cabling

D-type connector hoods. Hoods for 9-37 way D-type connectors made by *ODU UK* are quick to assemble, need no fixing screws and come in a choice of ten colours. They are made in one piece and snap to lock together, incorporating a quickly-assembled reversible cable clamp with self-tapping screws to enable the use of cables of varying diameters up to 15mm thick for the 37-way hood. All have a captive steel thumb screw. The connectors themselves are of the mixed variety, in which data, power, coaxial and high-voltage contacts can be used in the one shell. ODU UK Ltd, Tel., 01653 600489; fax, 01653 600493.

Bga socket. Methode's 1.27mm pitch ball-grid-array socket provides a simple means of removing the bga device from the board, effectively turning the bga device into a pin grid

Please quote "Electronics World" when seeking further information

array type for socket or through-hole mounting. It is compatible with all popular bga packages and heat sinks; it needs no hold-down device and the footprint is standard bga size. Insertion force is 2oz/position and withdrawal 0.35oz/position, with several choices of ejector. Contact rating is 0.5A dc at 20-40mΩ. Methode Electronics Europe Ltd. Tel., 01389 732123; fax, 01389 732777.

Crimps and housings. AMP CST-100 crimp contacts and housings are available with 2-28 positions pitched at 0.1in and are compatible with the Molex KK series. This is a low-cost wire-to-board connection with a 250V ac, 4A rating and contact resistance of 2mΩ. Both tin and gold-plated contacts are supplied and there is an overstress feature to prevent damage to the contact. Locking tabs and polarising tabs are standard. Gothic Crellon Ltd. Tel., 01734 788878; fax, 01734 776095.

Solderless connector. Surface Slack board-to-board connectors from Selwyn are fixed to the board by through-hole or threaded inserts, electrical connection to pads on the board being made by gas-tight beryllium-copper springs. There are models with from 22 to 78 contacts on a 1.27mm pitch. Selwyn suggests that the connectors are suitable for hand-held data collection devices, in which the pcb pads would be exposed for mating with the connector, avoiding the use of cables. Selwyn Electronics Ltd. Tel., 01732 763436; fax, 01732 763395.

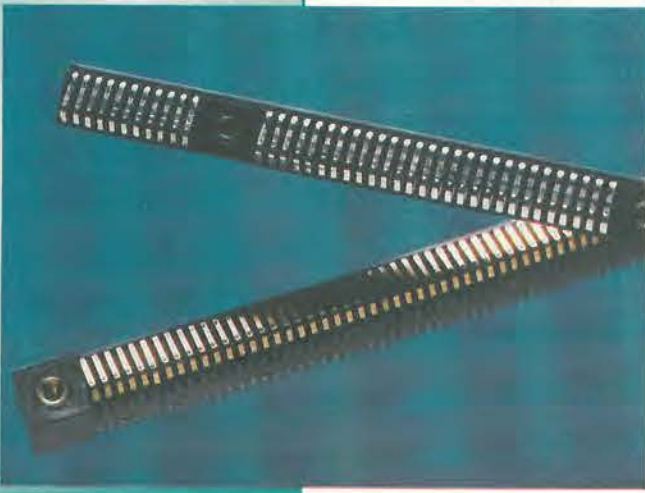

Crystals

Wide-pull oscillator. Model 937 from Oak Frequency Control Group is a high-frequency voltage-controlled crystal oscillator covering the 100-155.52 range of frequencies and is contained in a 16-pin dip. Output is ecl complementary in a variety of pin arrangements and standard frequency units are available from stock. Wyle Ginsbury Electronics Ltd. Tel., 01634 290903; fax, 01634 290903.

Test and measurement

Digital wattmeter. The Yokogawa WT1000 is a versatile digital power meter with a maximum bandwidth of 300kHz and working to an accuracy within 0.1%. It is available in single-phase or three-phase versions and there is a version for testing the performance of motors. Input range is 15V-1kV rms and a filter with a selectable cut-off frequency isolates fundamental frequencies in inverters to allow harmonic analysis on fundamentals from 440Hz to the 50th harmonic. On three phases, the instrument simultaneously measures the phase difference between phases and active, reactive and apparent power of the fundamental, simultaneously showing voltage, current and a choice of other quantities on four front-panel displays. Martron Instruments Ltd. Tel., 01494 459200; fax, 01494 535002.

Jitter tester for comms. JitterGEN from NoiseCom tests communications systems, PSTN, cellular and PCS base stations, for behaviour in the presence of digital noise to the specifications of AT&T, Accunet, TR62411 and international specs such as G.823 and G.702. The instrument provides controlled fm and pm jitter and wander in the 0.009Hz-400kHz range and unit interval-controlled jitter from 0 to 200ui, either under the control of an

external controller or stand-alone. Jitter is applied to a self-generated clock or to a data stream from another source and re-output to the system under test. Jittergen is contained in a portable unit with a fold-away keyboard, having a pc architecture and Windows gui. Sematron UK Ltd. Tel., 01256 812222; fax, 01256 812666.

Rf absorbing clamp. For the measurement of radiated emissions from the cables of electrical equipment, the EMC standard EN55014 specifies the use of an rf absorbing clamp, contrary to the impression many engineers have that a broadband antenna is needed. Laplace has such a clamp, the RF400, which consists of ferrite rings which open up to admit the cable and are then closed and held with no gap by springs. Insertion loss is ±1dB, maximum cable diameter is 18mm, load current is unlimited and there are wheels underneath the instrument so that it can be run along the cable. Instruments are supplied with a six-metre mains test cable and antenna factor data to load into a receiver or spectrum analyser. Laplace Instruments Ltd. Tel., 01692 500777; fax, 01692 406177.

CE-compliance tester. CE marking under the Low Voltage Directive now being in force, Seaward's new Premier LVD tester will help with the design of products to enable self-certification. It is microprocessor-controlled and contains all necessary data for testing to seven harmonised standards, accommodating ten programmable safety tests, manually or automatically. After selection of the standard, the instrument will carry out the sequence of tests and display the results on an lcd with pass or fail indication. Results are recorded and may be downloaded for printing. An optional Windows package is available to allow remote control from a pc. Accessories such as various probes and a remote-control earth bond can be supplied. Seaward Electronic Ltd. Tel., 0191 586 3511; fax, 0191 586 0227.

Lab. in a box. Several instruments from Feedback fit into one bench-top case, the 604 Mini-Lab. There is a 20MHz function generator with am/fm modulation producing sine, triangle, square, ramp and pulse waveforms, a 4-digit led readout being accurate to within ±1 count, and usable as a log/lin sweep generator; a 30MHz counter; a power operational amplifier; ±15V, 1A, adjustable dual or 5V, 3A power supplies; and a 3.5-digit multimeter measuring V, I, R and true rms. Feedback Test and Measurement. Tel., 01892 653322; fax, 01892 663719.

Fm/am signal generators. Kenwood announces the SG Series of programmable fm/am signal generators to cover the 100kHz-2GHz range of frequencies. SG-7200/7130 models go up to 2GHz and 1.3GHz respectively, being provided with a GPIB interface and modulation consisting of fm, am, am-fm and fm-fm simultaneously. Output levels increase in 0.1dB steps from -133dBm to 13dBm. SG-5150/5155 cover 100kHz-150MHz, the 5150 having fm stereo modulation and both having the GPIB interface. All have both rotary knobs and a keypad for control. Kenwood UK Ltd. Tel., 01923 218794; fax, 01923 212905.

Literature

Racks. Vero has published the KM6-II Selector to help engineers find their way through the maze of options available in sub-racking systems, explaining the choices of style and the sizes of Eurocard to fit, considerations discussed being screening, ease of assembly, cost and number of configurations. The same process is then carried out for front panels and plug-in units. Vero Electronics Ltd. Tel., 01703 266300; fax, 01703 265126.

Power supplies. In 216 pages, Chloride Powerline's new catalogue, The Power Guide, describes a range of linear and switched-mode supplies, dc-to-dc converters and inverters from many of the leading makers. It also contains applications information and data on safety standards and the EMC Directive. Chloride Powerline. Tel., 0118 9868567; fax, 0118 9755172.

Electromechanicals. Roxburgh can supply a catalogue of Grayhill components, featuring series encoders, push-buttons and keylock switches, a new section describing the full range of optical and mechanical decoders. Roxburgh Electronics Ltd. Tel., 01724 281770; fax, 01724 281650.

Frequency control. Fordahl GB (used to be McKnight Crystals) has a new catalogue of components and assemblies for a range of products for frequency control, such as quartz clock oscillators, voltage-controlled oscillators and crystal filters. Fordahl GB. Tel., 01703 877200; fax, 01703 846532.

Power supplies

High-reliability dc-to-dc converters. Interpoint has four new models in its MFL Series of converters, delivering 2V, 3.3V, 8V and 28V at up to 65W and intended for applications in which reliability is essential. All have a 16-40V dc input

range, nominal being 28V, they are isolated to 100MΩ at 500V dc and are synchronised for system work. Conversion frequency is 550-650kHz. Protection includes short-circuit, input transients and low-voltage lockout. All have the facility for parallel working for up to three units. Interpoint UK Ltd. Tel., 01252 815511; fax, 01252 815577.

3.3V/5V smps. New to Power-One's MAP110 range of universal-input, switched-mode supplies is the MAP110-4300, which provides, in addition to the 5V, 8A and ±12V, 1A, a 3.3V, 15A main channel, overvoltage protection being a feature of both 3.3V and 5V outputs. Others include zero minimum turn-on load, and optional power failure and thermal shutdown. Relevant standards requirements are met, an emi filter helping with FCC and CISPR 22 level B. The units come in three styles: open-board, with L brackets or totally enclosed. With forced air cooling, output is 110W or, with conventional cooling, 80W. Power-One Europe. Tel., 01769 540744; fax, 01769 540756.

100W pluggable supply. Vero's EC100 range of low-cost, pluggable switched-mode supplies provide 5V and 24V rails for both logic circuitry

Three channels, eight traces. Kenwood has two new oscilloscopes, the CS-5270/75, 100MHz bandwidth, three-channel, eight-trace instruments that offer ±3% measurement accuracy. Features include delayed sweep for expanded waveforms, single sweep and variable hold-off. There is automatic trigger and 1mV/div vertical sensitivity. The display is a 150mm rectangular tube with an internal graticule and illuminated scales, the 5270 also being provided with a digital readout and a cursor. Kenwood UK Ltd. Tel., 01923 218794; fax, 01923 212905.



and peripheral components such as relays and contactors. The supplies are in 3U by 12HP modules taking up three slot positions in a 19in rack and the rear heat sink is so designed to allow interfacing with both backplane and free-standing interconnection systems by way of a standard DIN41612 H15 connector. Versions are available to give 24V at 4A and 5V at 3A with power sharing, or 5V at 12A, 12V at 2A and -12V at 0.2A. Units are CE marked. Vero Electronics Ltd. Tel., 01489 780078; fax, 01489 780978.

Low-current voltage regulators. FET Electronics has a range of positive and negative regulators, FE 78LXXA and FE 8LXXA which, in a number of versions, provide fixed outputs from ±5V to ±18V at up to 100mA on inputs of ±25-35V. They are seen as replacements for resistor/zener combinations with much better performance and lower current. There is thermal shutdown and short-circuit current limiting. FET Electronics Ltd. Tel., 01635 524490; fax, 01635 552244.

Brighter ups. Five new accessory modules increase the intellect of Vero's SmartSlot range of intelligent, uninterruptible power supplies. The Interface Expander module enables one ups to handle three different servers, which may be running different operating systems. On power failure, the Expander signals each server to shut down gently, tells the ups to start battery conservation and then manages each system's reboot when mains power is restored. Measure-UPS monitors ambient temperature and humidity within set limits and uses other sensors to detect fire, unauthorised access, etc. The Remote UPS Management Device uses a modem to control the ups remotely and to initiate tests, dialling two pagers if anything is amiss. Relay I/O Module allow control and monitoring via a dry contact interface, the format used by pbx and alarm makers. Vero Electronics

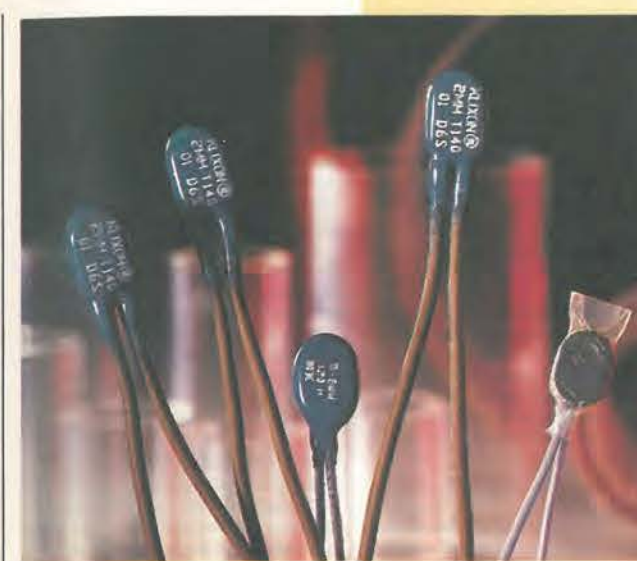

Ltd. Tel., 01703 266300; fax, 01703 265126.

Protection devices

Low-C transient suppressors. Semtech offers the LC03-6 transient voltage suppressor, which has a peak pulse power of 360W for a pulse width of 10ms and is designed to protect devices connected to ISDN interfaces and high-speed data comms lines from voltage surges caused by discharges, fast transients and lightning-induced spikes. Operating and clamping voltages are 6V and 12V and the design, consisting of a tvs diode and bridge rectifier, affords transient protection in both common and differential mode in the one device. Peak pulse current is 30A, leakage current 5μA and operating temperature -55°C to 150°C. Capacitance is 30pF. Semtech Ltd. Tel., 01592 773520; fax, 01592 774781.

Switches and relays

Separate membrane switches. From EAO-Highland comes the Series 70 range of pcb-mounted pushbuttons and spacers in the form of discrete membrane units, from which can be assembled a complete membrane switch panel, coloured caps and multi-chip or T1 led backlighting being available. EAO-Highland Electronics Ltd. Tel., 01444 236000; fax, 01444 236641.

Photo-interrupter. Isocom's ISTS802 optical interrupter has a 5mm wide slot for the opaque object to pass through and a light aperture of 0.5mm. Switching time is typically 3μs. There is a number of case styles with either pins or flying leads, special designs being made to order. Isocom Components Ltd. Tel., 01429 863609; fax, 01429 863581.

Please quote "Electronics World" when seeking further information

Thermal cut-outs. Texas Instruments' range of Klixon bi-metallic thermal trips now includes 2mm and 8mm versions with very reliable snap-action silver contacts. The smaller one can be installed in cavities in transformers and motors and has a layer of epoxy resin to protect it against transformer and motor impregnations. Rated at 3A and 7A, the larger type works over the 70-160°C temperature range in 5°C increments at a tolerance of ±5°C. Steatite Power Ltd. Tel., 0181 778 6611; fax, 0181 778 7722.

Television components

Wireless cctv. Radio Data Technology announces its VideoWave hand-portable viewer/receiver for surveillance work and for setting-up procedures with the VideoWave wireless transmission system. It needs no licence for use in the UK and works indoors or outside with no need for line-of-sight transmission paths. Features include signal scrambling and low power, a battery pack or lighter socket providing sufficient. The detachable viewer screen is a 2.9in lcd with a removable light shield. Radio Data Technology Ltd. Tel., 01376 501255; fax, 01376 501312.

Transducers and sensors

Sensor interface. Industrial sensor interface MCA7707 provides programmable analogue signal conditioning for silicon piezoresistive

Please quote "Electronics World" when seeking further information

sensors. It will calibrate and compensate transducers, several at a time if required, to better than $\pm 0.1\%$ total error over the industrial temperature range and, in conjunction with an EEPROM, store the calibration data and link to a PC via a parallel port. Both analogue and digital outputs are provided for pressure and temperature, a frequency output being obtained by using an external custom gate array. FET Electronics Ltd. Tel., 01635 524490; fax, 01635 552244.

Signal-conditioned accelerometer. Possibly the smallest conditioned dc-response accelerometer available, the Model 3255 from AG&G IC Sensors contains a micro-machined accelerometer die and an ASIC for signal conditioning, all in a 16-pin surface-mounted IC. In three versions handling $\pm 50g$, $\pm 250g$ and $\pm 500g$, typical sensitivity is 40, 8 and 4mV/g respectively at bandwidths of 2kHz, 3kHz and 3kHz. A self-test pin is provided, an electrostatic force moving the mass to simulate an acceleration. Over-range stops are

Optical encoders. Control Transducers offers the MD Series, a series of modular optical shaft encoders to detect position, speed and direction of movement, which are intended to supply feedback for position control in mechanical positioning equipment such as hydraulic presses or antenna positioning. Line counts are 96-2048 pulses per revolution, dual-channel, with or without index pulse and a line driver for long cable runs is available. The encoders, which have internal signal conditioning, are 25mm or 50mm in diameter and will take up an axial shaft play of ± 0.25 mm without damage. There is a variety of mounting accessories. Control Transducers. Tel., 01234 217704; fax, 01234 217083.



built in. Eurosensor. Tel., 0171 405 6060; fax, 0171 405 2040.

Hall sensor gives direction. Allegro has a family of Hall-effect sensors that provide contactless speed and direction sensing. A3420/1/2 contain two latches, the Hall elements being spaced 1.5mm apart. Each latch independently detects the ambient magnetic field to give high or low outputs, a subsequent logic circuit providing the direction signal. Latching means that the action requires a field reversal to operate, giving clean and positive switching. The chips contain internal voltage regulators for both analogue and digital circuitry. Allegro Microsystems Inc. Tel., 01932 253355; fax, 01932 246622.

Dual thermostat chip. Two thermostats sharing one sensor in National's LM56 operate from a 2.7V supply and need 230 μ A of quiescent current. The device contains a temperature sensor, two comparators and a reference in the one 8-pin IC, three external resistors serving to set up trip points from -40°C to 125°C . An additional analogue output provides 6.25mV/ $^{\circ}\text{C}$ with good linearity. Hysteresis over the whole range is 5 $^{\circ}$. Applications will include the control of system fans. National Semiconductor GmbH. Tel., 0049 1805 32 7832; fax, 0049 814103515.

Small speakers. Kingstate miniature waterproof speakers have Mylar cones, a rated input of 0.5W and come in impedances in the 8-500 Ω range. In a number of frame styles, sizes are from 20mm to 50mm diameter, frames being in metal or ABS, 5mm in depth, some cased for PCB mounting. There are units for voice to 4kHz or for full-range working up to 9kHz. Roxburgh Electronics Ltd. Tel., 01724 281770; fax, 01724 281650.

Vision systems

Conference camera. eaZy is a colour CCD camera for video



conferencing (conferring?) that gives video and audio output to interface to MPEG or similar computer cards. Resolution is 320 000 pixels from a 0.25in CCD sensor through a 4mm, f3.8 lens with a built-in colour filter. It works in light levels from 10lux, 500lux being recommended, and there is an auto-white balance and electronic shutter with speeds from 1/50s to 1/120s. Voltage requirement of 5V can be obtained from the host in most cases. Premier Electronics Ltd. Tel., 01922 634652; fax, 01922 634616.

COMPUTER

Computers

Reconfigurable hardware. Embedded Solutions announces its first product, the Accelerator, which can be used to increase integer performance of processors, to provide customised interfaces to external devices, for prototyping and evaluation or for building scalable computing systems. Its main feature is the use of two field-programmable gate arrays instead of a conventional processor, an approach that offers the possibility of reorganising the hardware in a different configuration. Two Xilinx field-programmable gate arrays are connected to each other and to a daughter board, the connector to which may be used to interface the board to input/output devices or to make network interfaces between Accelerators and other devices. A companion communications board allows connection to transputer networks, converting an OS serial link to two parallel buses, linked to as many Accelerators as necessary. Embedded Solutions Ltd. Tel. and fax; 0118 9771682.

Data acquisition

Anti-alias cards. From Laplace Instruments, the AAF-16 16-channel anti-alias filter card for data acquisition using a PC. Filters can be specified as Bessel, Butterworth, Cauer or linear phase types, depending on the application, roll-off being up to 120dB/octave for the Cauer. Cut-off frequency is programmed from the PC from 2Hz to 50kHz or 100kHz, depending on filter type. Single-ended inputs are at 2M Ω impedance and the input range is ± 10 V, with protection to 120V rms and 250V for 5s. An optional daughter board provides protection against clock aliasing. Software supplied includes Windows in its various incarnations and Dos programs for setting key parameters and drivers compatible with Visual Basic, Visual C++, C and Pascal; drivers for LabView are also available. Laplace Instruments Ltd. Tel., 01692 500777; fax, 01692 406177.

Data communications

Data/fax modems. ClipperCom World by Apex Data is a PC Card data and fax modem providing 33.6kb/s V.34 performance with MNP2-4 and V.42 error correction, and MNP-5 and V.42.bis data compression. Software included allows faxes to be sent directly from applications and to be scheduled for later transmission, faxes being sent and received in the background. The card is compatible with many notebook computers and with Windows 3.X, 95, NT Workstation, OS/2 and Dos. DIP Systems. Tel., 01483 202070; fax, 01483 202023.

Data logging

Black box for vehicles.

RoadRecorder is a video logging system for buses, trains, police cars, etc., that collects relevant data in much the same way as does the flight recorder found in aircraft. Video and other types of data are logged and saved to hard disk to provide information on accidents or crime. On buses or trains, it is envisaged that there may be several video cameras inside and around the outside to provide internal security and to deter vandals. There could also be one pointed forward to record what happens in accidents. A GPS navigation and location device might be integrated with the system. Visimetrix UK Ltd. Tel., 01436 677557; fax, 01436 672131.

Multimedia

Web guide to CE marking. If, after reading leaflets, books and posters, watching videos and using computer programs, you are still baffled by CE marking, you can now catch it all on the Worldwide Web site of the Assessment Services. It shows which Directives apply to common products, although "...obviously the list is not exhaustive...". Highlighting a product brings up the Directives for that product and what you have to do to make sure it conforms to Holy

Writ. If you already know which Directives are relevant, you can see more information on any of six specific Directives applicable to most electrotechnical products. You can also ask questions by e-mail. To see all this try <http://www.neag.co.uk/cgi-bin/ce-mark.cgi> "and get in the fast lane to compliance". Assessment Services' Tel., 01329 443350; fax, 01329 443421.

Computer security

Computer safe. If a technically inclined tealeaf is intent upon stealing a computer's memory, nothing will stop him, but the Armagard family of computer safes will at least give him pause for thought; the Crown Jewels spring to mind. Latest in the range is the one for Mini Tower PCs; the computer covers inside a 2mm thick steel box that has a seven-lever mortice lock. The whole thing bolts to the desk, has an inset door with concealed hinges, is of welded construction and is fitted with dog-bolts so that the door cannot be removed without unlocking it. There is a brush strip for cables at the rear, ventilation is taken care of and a fan can be fitted. Computers up to 350mm high, 220mm wide and 500mm deep fit inside and stay there while working.

Intek Electronics Ltd. Tel., 01352 810603; fax, 01352 810403.

Software

Efficient C compiler. Version 4 of Cosmic Software's C cross compiler for 68HC11 microcontrollers is source-code-compatible with earlier versions but has a new C driver structure for multipass processes, new unified compiler options and a 32-bit internal data structure for unrestricted development of new code optimisation. There is also a new C parser for optimisation before compiling. The company says that Version 4 is a virtually new package, methods used in earlier ones having reached a limiting point. This one is said to produce the most efficient code for the 68HC11. Included in this full ANSI C package are a macro assembler, linker, librarian, object inspector, hex file generator, object format converters, debugging support, a royalty-free run-time library source code and a multipass compiler command driver. Cosmic Software. Tel., 0118 9880241; fax 0118 9880360.

Software verification for VME. In its latest version, CodeTEST from AMC is applied to VMEbus system software for test and analysis. CodeTEST-VME will trace the code

execution of a CPU or follow the workings of several CPUs via VME system trace. The package consists of a single-slot 6U board, plugging into the VMEbus backplane, and application software modules for in-circuit verification of software performance, memory allocation analysis and deep trace capability; it runs on H-P and Sun workstations and PCs running Windows 95 or NT. Applied Microsystems Corporation Ltd. Tel., 01296 625462; fax, 01296 623460.

Waveform analysis. For use with its dsos, data acquisition systems and recorders, Gould has introduced ProView, an analysis and report generating package. Its features include display and manipulation facilities, a search function for points of interest in waveforms and a document composition tool to assist in making reports. The package is to be used with the company's Transition 2, View II or View-to-ASCII linking software to connect ProView with digital storage oscilloscopes or to signals on disk and memory cards in recorders and data systems. Analysis includes a variety of statistical and mathematical functions and those in the frequency domain. Gould Instrument Systems Ltd. Tel., 0181 500 1000; fax, 0181 501 0116.

ADVERTISE FREE OF CHARGE

Subscribers* to Electronics World can advertise their electronics and electrical equipment completely free of charge

Simply write your ad in the form below, using one word per box, up to a maximum of twenty words. Remember to include your telephone number as one word. You must include your latest mailing label with your form.

* This free offer applies to private subscribers only. Your ad will be placed in the first available issue.

This offer applies to private sales of electrical and electronic equipment only.

Trade advertisers - call Malcolm Wells on 0181-652 3620

All adverts will be placed as soon as possible. However, we are unable to guarantee insertion dates. We regret that we are unable to enter into correspondence with readers using this service, we also reserve the right to reject adverts which do not fulfil the terms of this offer.

Please send your completed forms to:

Free Classified Offer: Electronics World, L333, Quadrant House, The Quadrant, Sutton, Surrey SM2 5AS

CD Jitter bug

Chris Daly believes that his enhancement to the interface between a cd player's transport and its d-to-a converter improves sonic performance by reducing problems associated with signal jitter.

All compact-disc player transports incorporate a processing ic that reads the eight-to-fourteen modulation, or efm, signal. This chip provides the Sony/Philips digital-interface format, of SPDIF, signal as one of its many outputs. It also interfaces with either a combined oversampling d-to-a converter or to a separate oversampler and converter.

Jitter in the interface data stream produces clock jitter at the d-to-a converter, degrading the audio quality¹. The way that the processor interfaces with the oversampler and converter is the topic of this discussion. I will outline a new method of conveying the digital information providing improved integrity relative to the accepted SPDIF standard.

Individual signals involved are data, bit-clock and left/right clock. Manufacturers name these signals with some uniformity. The Burr-Brown *DF1700* application data is useful in this regard.

The advantage of my new method is that the identity of each clock signal can at last be properly recognised. I am not the first to provide an alternative method. One of the earliest references I can recall is Stan Curtis of

Cambridge, who provided such an enhancement in the *CDI* player.

The above-mentioned signals feed from the processor ic of the cd player/transport to the oversampling ic. In the case of the main bit clock signal, this travels back from the oversampling ic to the processor. All the signals travel over circuit-board tracks with a length of between 20 and 50mm and can become corrupted.

Using interpolation improves signal integrity. D-type bistable ics can be seen as single-sample interpolators. The method is to use the existing clock in the player/transport to clock the processor. Each of the three *74AC74* bistable devices is arranged to interpolate the bit clock, the data signal, and the left/right clock relative to the existing clock. Output Q of the aforementioned bistable ics then exits the player using rf terminations. It is advisable to use Van den Hul *D300 MKIII* coaxial cable with good BNC or TNC plugs and sockets.

On arrival at the digital-to-analogue converter, these same signals need terminating again. The data signal, bit clock and left/right clock signals enter the data inputs of *74AC74* bistables which have a clock reference from

the Xti/Xto pin of the oversampling ic. This is usually available via a buffer, for example at pin 9 of the Burr Brown *DF1700*.

Finally, the signals exit at the Q output of each bistable device to interface with the oversampling ic inputs, called bit-clock input, data input and left/right clock input.

Reset of all bistable devices and reset of oversampling ic are returned to the XRST line of player. The 'set' inputs of the bistables are held high and the ground of the player and d-to-a converter are linked.

Linking the modification

Some 70% of cd player transports are Sony types and hence similar. Within these, 330 to 470Ω resistors usually interface each signal to the player's digital filter. These provide easy access to the signals. It is advisable branch the signals to the input of the bistable devices with a similar value resistor.

Usually, the clock signal feeds the cd-player transport's digital filter, which then outputs to the decoder's XTAI input. Once again, this signal is usually resistor coupled and similar branching can be used to couple the signal to the bistable ic clock inputs.

Connection into the d-to-a converter requires either removal of the digital receiver or breaking of the bit clock, data and left/right clock connections feeding the digital filter. Often, the receiver is a *CS8412*.

The prescribed modification no longer involves decoding of a clock signal. As a result, it is necessary to provide a *74AC04* clock driver to drive XTI of the digital filter. Alternatively, the digital filter's XTI/XTO and clock output (CKO on the Burr Brown *DF1700*) facilities could be used to drive the bistable ic clock inputs.

Both of the above methods require a crystal for the digital filter operating at 256fs, i.e. 11.2896MHz, or 384fs, or 16.9344MHz.

In my experience the enhancement works exceptionally well. My cd player is a Pioneer 701, *Audio Synthesis DSM UA*.

Reference
1. Fourre, R., What is jitter, *Stereophile*, October 1993.

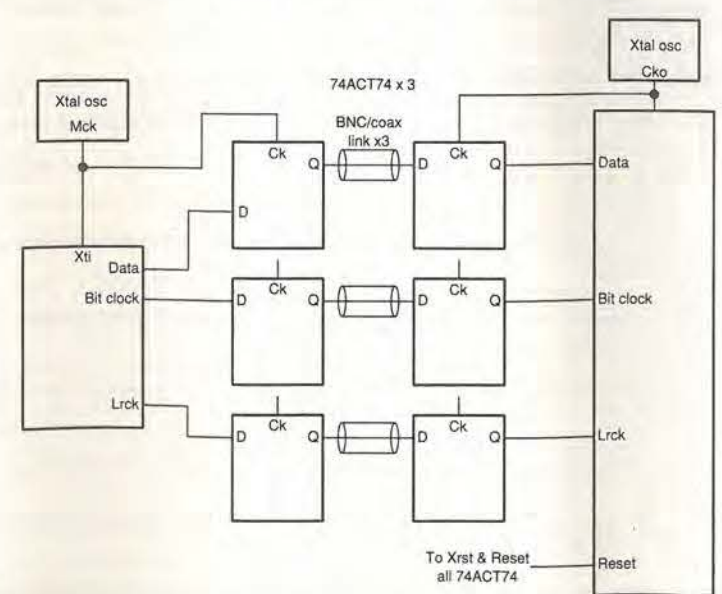

DIFFERENTIAL THERMOSTAT KIT Perfect for heat recovery, solar systems, boiler efficiency etc. Two sensors will operate a relay when a temp difference (adjustable) is detected. All components and pcb. £29 ref LOT93

MAGNETIC RUBBER TAPE Selfadhesive 10 metre reel, 8mm wide perfect for all sorts of applications! £15 ref LOT87

MAINS POWER SAVER UK made plug in unit, fitted in seconds, can reduce your energy consumption by 15%. Works with fridges, soldering irons, conventional bulbs etc. Max 2A rating. £9 each ref LOT71, pack of 10 £89 ref LOT72

YUASHA SEALED LEAD ACID Batteries, ex equipment but ok bargain price just £5.99 each ref YA1. 100 or more £3.50 each.

DC TO DC CONVERTERS

DRM58 input 10-40vdc output 5v 8A £15 DRM128 input 17-40vdc output 12v 8A £18 DRM158 input 20-40vdc output 15v 8A £18 DRM248 input 29-40vdc output 24v 8A £12 DRS123 input 17-40vdc output 12v 3A £10 DRS153 input 20-40vdc output 15v 3A £20 DRS243 input 29-40vdc output 24v 3A £8

HITACHI LM225X LCD SCREENS 270x150mm, standard 12 way connector, 640x200 dots, tec spec sheet, £15 each ref LM2

VARIABLE CAPACITORS Dual gang, 60x33x45mm, reduction gearing, unknown capacity but probably good quality (military spec) general purpose radio tuner. £9 ref VC1

ELECTRONIC FLASH PCB Small pcb fitted with components including a flash tube. Just connect 12vdc and it flashes, variable speed potentiometer. £6 ref FLS1

THIEF PROOF PEN! Amazing new ball point pen fitted with a combination lock on the end that only you know! £2.49 ref TP2

JUMBO BI COLOUR LEDS PCB with 15 fitted also 5 giant seven segment displays (55mm) £8 ref JUM1

HOME DECK CLEARANCE These units must be cleared! leads, a n infra red remote qwerty keyboard and receiver, a standard UHF modulator, a standard 1200/75 BT approved modem and loads of chips, capacitors, diodes, resistors etc all for just £10 ref BAR33

6.8MW HELIUM NEON LASERS New units, £65 ref LOT33

COIN SLOT TOKENS You may have a use for these? mixed bag of 100 tokens £5 ref LOT20

PORTABLE X RAY MACHINE PLANS Easy to construct plans on a simple and cheap way to build a home X-ray machine! Effective device, X-ray sealed assemblies, can be used for experimental purposes. Not a toy or for minors! £65 ref F/XP1

TELEKINETIC ENHANCER PLANS Mystify and amaze your friends by creating motion with no known apparent means or cause. Uses no electrical or mechanical connections, no special gimmicks yet produces positive motion and effect. Excellent for science projects, magic shows, party demonstrations or serious research & development of this strange and amazing psychic phenomenon. £4 ref F/ITKE1

ELECTRONIC HYPNOSIS PLANS & DATA This data shows several ways to put subjects under your control. Included is a full volume reference text and several construction plans that when assembled can produce highly effective stimuli. This material must be used cautiously. It is for use as entertainment at parties etc only, by those experienced in its use. £15 ref F/IEH2

GRAVITY GENERATOR PLANS This unique plan demonstrates a simple electrical phenomena that produces an anti-gravity effect. You can actually build a small compass out of simple materials and without any visible means - cause it to levitate. £10 ref F/IGRA1

WORLDS SMALLEST TESLA COIL/LIGHTNING DISPLAY GLOBE PLANS Produces up to 750,000 volts of discharge, experiment with extraordinary HV effects, 'Plasma in a jar', St Elmo's fire, Corona, excellent science project or conversation piece. £5 ref F/BTC1LGS5

COPPER VAPOUR LASER PLANS Produces 100mw of visible green light. High coherency and spectral quality similar to Argon laser but easier and less costly to build yet far more efficient. This particular design was developed at the Atomic Energy Commission of NEGEV in Israel. £10 ref F/ICVL1

VOICE SCRAMBLER PLANS Miniature solid state system turns speech sound into indecipherable noise that cannot be understood without a second matching unit. Use on telephone to prevent third party listening and bugging. £6 ref F/VSS9

PULSED TV JOKER PLANS Little hand held device utilises pulse techniques that will completely disrupt TV picture and sound! works on FM too! DISCRETION ADVISED. £8 ref F/ITJ5

BODYHEAT TELESCOPE PLANS Highly directional long range device uses recent technology to detect the presence of living bodies, warm and hot spots, heat leaks etc. Intended for security, law enforcement, research and development, etc. Excellent security device or very interesting science project. £8 ref F/BHT1

BURNING, CUTTING CO2 LASER PLANS Projects an invisible beam of heat capable of burning and melting materials over a considerable distance. This laser is one of the most efficient, converting 10% input power into useful output. Not only is this device a workhorse in welding, cutting and heat processing materials but it is also a likely candidate as an effective directed energy beam weapon against missiles, aircraft, ground-to-ground, etc. Particle beams may very well utilize a laser of this type to blast a channel in the atmosphere for a high energy stream of neutrons or other particles. The device is easily applicable to burning and etching wood, cutting, plastics, textiles etc £12 ref F/ILC7

MYSTERY ANTI GRAVITY DEVICE PLANS Uses simple concept. Objects float in air and move to the touch. Defies gravity, amazing gift, conversation piece, magic trick or science project. £6 ref F/ANTIK

FRUIT POWERED CLOCK Just add a fresh orange, tomato, banana or any other fruit plug in the probes and the clock works! £9.95 ref SC154

DYNAMO FLASHLIGHT Interesting concept, no batteries needed just squeeze the trigger for instant light apparently even works under water in an emergency although we haven't tried it yet! £6.99 ref SC152

ULTRASONIC BLASTER PLANS Laboratory source of sonic shock waves. Blow holes in metal, produce 'cold' steam, atomize liquides. Many cleaning uses for PCB boards, jewellery, coins, small parts etc. £6 ref F/ULB1

ULTRA HIGH GAIN AMP/STETHOSCOPIC MIKE/SOUND

AND VIBRATION DETECTOR PLANS Ultrasensitive device enables one to hear a whole new world of sounds. Listen through walls, windows, floors etc. Many applications shown, from law enforcement, nature listening, medical heartbeat, to mechanical devices. £6 ref F/HGA7

WOLVERHAMPTON ELECTRONICS STORE NOW OPEN IN WORCESTER ST TEL 01902 22039

ANTI DOG FORCE FIELD PLANS Highly effective circuit produces time variable pulses of acoustical energy that dogs cannot tolerate £6 ref F/DOG2

LASER BOUNCE LISTENER SYSTEM PLANS Allows you to hear sounds from a premises without gaining access. £12 ref F/LLIST1

LASER LIGHT SHOW PLANS Do it yourself plans show three methods. £6 ref F/LLS1

PHASOR BLAST WAVE PISTOL SERIES PLANS Handheld, has large transducer and battery capacity with external controls. £6 ref F/PSP4

INFINITY TRANSMITTER PLANS Telephone line grabber/room monitor. The ultimate in home/office security and safety! simple to use! Call your home or office phone, push a secret tone on your telephone to access either: A) On premises sound and voices or B) Existing conversation with break-in capability for emergency messages. £7 ref F/TELEGRAB

BUG DETECTOR PLANS Is that someone getting the goods on you? Easy to construct device locates any hidden source of radio energy! Sniffs out and finds bugs and other sources of bothersome interference. Detects low, high and UHF frequencies. £5 ref F/BD1

ELECTROMAGNETIC GUN PLANS Projects a metal object a considerable distance - requires adult supervision £5 ref F/EML2

ELECTRIC MAN PLANS, SHOCK PEOPLE WITH THE TOUCH OF YOUR HAND! £5 ref F/EMA1

PARABOLIC DISH MICROPHONE PLANS Listen to distant sounds and voices, open windows, sound sources in 'hard to get' or hostile premises. Uses satellite technology to gather distant sounds and focus them to our ultra sensitive electronic. Plans also show an optional wireless link system. £8 ref F/FPM5

2 FOR 1 MULTIFUNCTIONAL HIGH FREQUENCY AND HIGH DC VOLTAGE, SOLID STATE TESLA COIL AND VARIABLE 100,000 VDC OUTPUT GENERATOR PLANS Operates on 9-12vdc, many possible experiments. £10 ref F/HVM7/TCL4

MEGA LED DISPLAYS PCB fitted with 5 seven segment displays each measuring 55 x 38mm. £5 ref LED5

MOD TRANSMITTING VALVES 5J180E £80 ref LOT112

SWITCHED MODE PSUs 244 watt, +5 32A, +12 6A, -5 0.2A, -12 0.2A. There is also an optional 3.3v 25A rail available. 120/240v I/P. Cased, 175x90x145mm. IEC inlet Suitable for PC use (6 drive connectors 1 m/board). £15 ref LOT135

HYDROGEN FUEL CELL PLANS There is a lot of interest in using Hydrogen as the fuel of the future, Hydrogen is easy to produce using chemicals and surplus solar generated electricity. It is also easy to store with little or no loss. Hydrogen fuel cells are designed to store hydrogen and weight for weight will hold twice as much energy as a full petrol tank. Our plans give you loads of information on Hydrogen production, storage and practical plans to build your own Hydrogen fuel cell! you will need access to a well equipped workshop for this but full construction details and drawings are included. Full cell plans £9 ref HY1

VIDEO PROCESSOR UNITS 7/6V 10AH BATT/24V 8A TX Not too sure what the function of these units is but they certainly make good strippers! Measures 390x320x120mm, on the front are controls for scan speed, scan delay, scan mode, loads of connections on the rear. Inside 2 x 6V 10AH sealed lead acid batts, pcb's and a 6A? 24v toroidal transformer (mains in), solder as seen, may have one or two broken knobs etc due to poor storage. £15.99 ref VP2

RETRON NIGHT SIGHT Recognition of a standing man at 300m in 1/4 moonlight, hermetically sealed, runs on 2 AA batteries, 80mm F1.5 lens, 20mw infrared laser included. £325 ref RETRON

MAKE YOUR OWN CHEWING GUM KIT Everything you need to make real chewing gum, even the bowl and treesap from the Sapodilla tree £7.99 ref SC190

MINI FM TRANSMITTER KIT Very high gain preamp, supplied complete with FET electret microphone. Designed to cover 88-108 Mhz but easily changed to cover 63-130 Mhz. Works with a common 9v (PP3) battery. 0.2W RF. £9 ref 1001

3-30V POWER SUPPLY KIT Variable, stabilized power supply for lab use. Short circuit protected, suitable for professional or amateur use 24v 3A transformer is needed to complete the kit. £14 ref 1007

1 WATT FM TRANSMITTER KIT Supplied with piezo electric mic. 8-30vdc. At 25-30v you will get nearly 2 watts! £15 ref 1009

FMAIAM SCANNER KIT Well not quite, you have to turn the knob your self but you will hear things on this radio that you would not hear on an ordinary radio (even TV). Covers 50-160mhz on both AM and FM. Built in 5 watt amplifier, inc speaker. £18 ref 1013

3 CHANNEL SOUND TO LIGHT KIT Wireless system, mains operated, separate sensitivity adjustment for each channel, 1,200 w

BULL ELECTRICAL
250 PORTLAND ROAD, HOVE, SUSSEX.
BN3 5QT. (ESTABLISHED 50 YEARS).
MAIL ORDER TERMS: CASH, PO OR CHEQUE
WITH ORDER PLUS £3.50 P&P PLUS VAT.
24 HOUR SERVICE £4.50 PLUS VAT.
OVERSEAS ORDERS AT COST PLUS £3.50
(ACCESS, VISA, SWITCH, AMERICAN EXPRESS)
'phone orders : 01273 203500
FAX 01273 323077
E-mail bull@pavilion.co.uk

FREE COLOUR CATALOGUE WITH EVERY ORDER
WE BUY SURPLUS STOCK FOR CASH
SURPLUS STOCK LINE 0802 660335

CIRCLE NO. 108 ON REPLY CARD

Transform your PC

into a digital oscilloscope, spectrum analyser, frequency meter, voltmeter, data logger .. for as little as £49.00

Pico Technology specialises only in the development of PC based data acquisition instrumentation. **Call for your guide on 'Virtual Instrumentation'.**

The ADC-10 supplied with PicoScope gives your computer a single channel of analog input. **ADC-10 £49 with PicoLog £59**

Virtual Instrumentation

Pico's PC based oscilloscopes simply plug into the parallel port turning your PC into a fully featured oscilloscope, spectrum analyser and meter. Windows and DOS software supplied.

ADC-100 Dual Channel 12 bit resolution

The ADC-100 offers both a high sampling rate 100kHz and a high resolution. Flexible input ranges ($\pm 50\text{mV}$ to $\pm 20\text{V}$) make the unit ideal for audio, automotive and education use.

ADC-100 £199 ADC-100 with PicoLog **£219**

ADC-200 Digital Storage Oscilloscope

- 50 MSPS Dual Channel Digital Storage Scope
- 25 MHz Spectrum Analyser
- Windows or DOS environment
- $\pm 50\text{mV}$ to $\pm 20\text{V}$
- Multimeter
- 20 MSPS also available

ADC 200-20 £359.00

ADC 200-50 £499.00

Both units are supplied with cables, power supply & manuals.

Pico Technology Ltd. Broadway House, 149-151 St Neots Rd, Hardwick, Cambridge. CB3 7QJ UK

Tel: + 44 (0)1954 211716 Fax: + 44 (0)1954 211880 E-mail: post@picotech.co.uk Web: http://www.picotech.co.uk/

Phone or FAX for sales, ordering information, data sheets, technical support. All prices exclusive of VAT

Data Logging

Pico's range of PC based data logging products enable you to easily measure, display and record temperature, pressure and voltage signals.

TC-08 Thermocouple to PC Converter

- Supplied with PicoLog software for advanced temperature processing, min/max detection and alarm.
- 8 Thermocouple inputs
- No power supply required.

TC-08 £199

TC-08 £224 with cal. Cert.

complete with serial cable & adaptor. Thermocouple probes available.

Call for free demo disk and product range catalogue

Post & Packing UK **£3.50**, Export customers add **£9** for carriage & insurance.



PICO
Technology Limited

releasing PC potential

CIRCLE NO. 117 ON REPLY CARD

ADVERTISE FREE OF CHARGE

Subscribers* to Electronics World can advertise their electronics and electrical equipment completely free of charge

Simply write your ad in the form below, using one word per box, up to a maximum of twenty words. Remember to include your telephone number as one word. You must include your latest mailing label with your form.

* This free offer applies to private subscribers only. Your ad will be placed in the first available issue.

This offer applies to private sales of electrical and electronic equipment only.

Trade advertisers - call Joannah Cox on 0181-652 3620

All adverts will be placed as soon as possible. However, we are unable to guarantee insertion dates. We regret that we are unable to enter into correspondence with readers using this service, we also reserve the right to reject adverts which do not fulfil the terms of this offer.

Please send your completed forms to:

Free Classified Offer: Electronics World, L333, Quadrant House, The Quadrant, Sutton, Surrey SM2 5AS

Programmable logic

Geoff Bostock looks at the most popular language used to describe logic systems - VHDL - and discusses how schematics are turned into code for programmable devices.

Hardware description languages, or HDLs, are a more generalised method of describing the behaviour of logic systems than logic equations. However, they do embody some of the characteristics of logic and state equations. In this next section, I concentrate on one particular language - VHDL.

This language is becoming an industry standard, spurred on by MIL STD 454L, which requires all ASIC designs for the USA Defense Department to be documented in this language. It was devised as part of the VHSIC, or very high-speed integrated circuit, project to allow complex ASICs to be specified and simulated without reference to any specific technology. Having specified a circuit in this way, it should be transferable to any process or manufacturer with guaranteed reproducibility.

VHDL, an abbreviation derived from VHSIC HDL, describes logic systems from a top-down architectural standpoint. A system is visualised as a set of 'black boxes', called entities, with a set of interfaces. Top level entities may be broken into successively less complex functions until the bottom level is reached; this may be a

gate-level description of the function.

Because each level of the logic hierarchy is specified uniquely, each may be simulated to check both syntax and logic function. The lowest level may be validated first so that a completely tested system is built from the bottom up. This is followed by a synthesis step which translates the whole design to the logic cell level after which it is simulated at gate level with built-in timing parameters.

This hierarchical design allows whole systems to be defined without specifying technology, or even partitioning into devices. The whole process is akin to designing software in a high-level language, with the low-level entities playing the same role as subroutines. A complete system may be defined and then tested without specifying a target device. The modules are designed separately and may be stored and used over again in future designs; in effect a library of functions is generated for re-use in new designs.

VHDL logic specification

Examples of VHDL definitions can show the difference between basic equations and HDL constructs. A four-bit

This article is derived from Geoff Bostock's new book 'FPGAs and programmable LSI - a designer's handbook'. The work covers designing FPGAs, large PAL structures, RAM and antifuse-based FPGAs and FPGA selection. Comprising 215 pages, this book is available by sending a postal order or cheque with a request for the book to Electronics World, Quadrant House, The Quadrant, Sutton, Surrey SM2 5AS. The fully-inclusive price is £27.50 UK, £30 Europe or £33 rest of world. Alternatively, fax your full credit card details and address on 0181 652 8956 or e-mail jackie.lowe@rbp.co.uk.

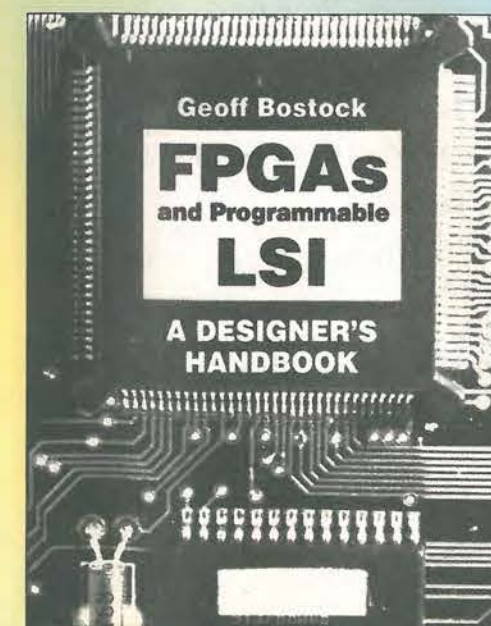

Geoff Bostock runs his own FPGA/PLD Design Consultancy, and may be contacted on 01380 828241, or by e-mail at geoff.bostock@zetnet.co.uk

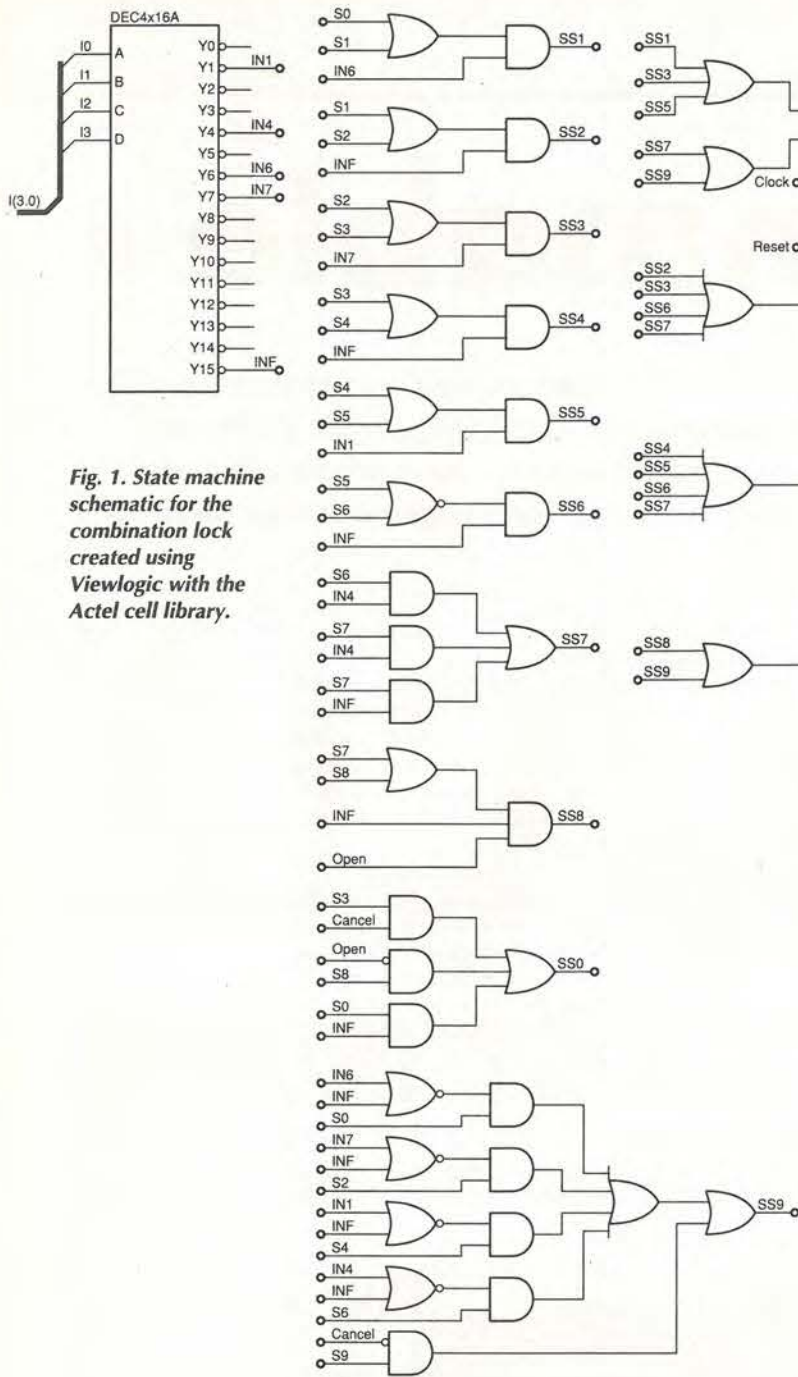

Fig. 1. State machine schematic for the combination lock created using Viewlogic with the Actel cell library.

arbitrary as it is ignored in the compilation process; it is good practice to make it relevant to the way in which the architecture is being defined. Here, we are using a high-level description which will be understood during simulation but might need synthesising at a lower level to achieve a good performance.

Lower level definition is generally specified as rtl, or register transfer level, which does not need to involve registers. The '<=' symbol represents the function 'signal assignment'; in the adder, the value of A+B is transferred to C.

In a multi-transfer definition all assignments are made concurrently. VHDL differs from software programming languages in this respect; in a programming language, the order in which commands are written defines the order in which they happen, in VHDL the simulator assumes that all signal transfers are simultaneous, except where sequential processes are defined.

A multiplexer specified to operate as a discrete logic '157 type illustrates the structure of an rtl function definition,

```
entity MUX157 is
  port( A, B: in BIT_VECTOR( 0 to 3);
        G, SEL: in BIT;
        Y: out BIT_VECTOR( 0 to 3));
end MUX157;
architecture RTL of MUX157 is
begin
  Y<= '0' when (G= '1') else
    B when (G= '0' and SEL = '1') else
    A
end ;
```

In order to specify state machines it is necessary to invoke sequential statements which occur within a process. The process itself is concurrent because it may be called at any time, when one of its signals changes. Essentially, a state machine consists of two parts – a sequential part which defines the ability of bistable devices to change state, and a combinatorial part which defines the signals offered to the bistable device as a function of present state and inputs.

adder may be defined as follows,

```
entity ADDER4 is
  port( A,B: in INTEGER range 0 to 15;
        C: out INTEGER range 0 to 15 );
end ADDER4;
```

The entity section defines the signal interfaces and sizes. Defining a range of 0 to 15 implies that each signal has four bits. It must be followed by an architecture section to define the logic relationship between the signals. This may be written as:

```
architecture BEHAVIORAL of ADDER4 is
begin
  C<=A+B;
end BEHAVIORAL;
```

The type of architecture, in this case BEHAVIORAL, is

List 1. Code for combination lock logic.

```
entity DOOR_LOCK is
  port ( OPEN, CANCEL in bit;
        CLOCK, RESET in bit;
        I in BIT_VECTOR (3 down to 0);
        UNLOCK, ALARM out bit);
end DOOR_LOCK
architecture RTL of DOOR_LOCK is
  --double hyphen is VHDL comment syntax
  --now define internal signals which are not signal ports
  --by first defining types for the state signals
  type StateType is (S0, S1, S2, S3, S4, S5, S6, S7, S8, S9);
  --then we define the signals we are going to use
  signal State, NextState: StateType;
begin
  SEQUENCE: process ( CLOCK, RESET)
  --this defines a process called SEQUENCE which is
  --invoked whenever there is a change in the value
  --of CLOCK or RESET
  begin
    if (RESET = '0') then
      State <= S0;
    --then we define a rising clock edge by
    elsif (CLOCK'event and CLOCK = '1') then
      State <= NextState;
    end if;
  end process;
  --we can now define the state jumps as a
  --combinatorial process
  COMBINATORIAL: process (I, OPEN, CANCEL, State)
  begin
    --assign default output levels
    UNLOCK <= '0';
    ALARM <= '0';
    case State is =>
      when S0=>
        if (I = 6) then
          NextState <= S1;
        elsif (I/= 6 and I/= 15) then
          NextState <= S9;
        end if;
      when S1=>
        if (I = 15) then
          NextState <= S2;
        end if;
      when S9=>
        ALARM <= '1';
        if (CANCEL = '1') then
          NextState <= S0;
        end if;
    end case;
  end process ;
end RTL;
```

The door lock described in the May issue may be specified as in List 1. This listing is the complete specification for the door lock function. A function of this size would normally form only part of a complete fpga so the above would be just one entity of a total design listing.

Having defined a logic entity it may be used as often as desired within the whole design. Each use of the function is given a unique name and referred to this specification. This process is called instantiation because each time the logic module is called up it forms an instance of that logic.

It is usual to verify each entity individually before connecting them together in the top level design. This requires a simulation routine to be devised and written, as described in the next section.

Simulation with VHDL

In order to simulate an entity – or a complete design – a test bench must be created. The syntax for this is similar to the syntax for specifying logic entities. For example, the entity declaration will be:

```
entity TEST_DOOR_LOCK is
```

```
end TEST_DOOR_LOCK;
```

This defines the test bench because it has no ports, only signal drivers. The architecture must define the signals, components and stimuli. It does this in the same way as in a logic architecture, List 2.

Finally, the results must be written to a file so that they can be examined to assess whether the simulation has achieved the desired result. VHDL includes a standard package – TEXTIO – to manage this function.

Capturing circuit schematics

Schematic capture is probably still the most popular method of defining logic for field-programmable gate arrays, and many ASICs. It is a computer-aided design system dedicated to logic design.

Logic functions of complexity ranging from an inverter to multi-bit counters are stored in a library which describes both their functions and a graphical symbol. The designer calls up the symbols from the library, places them on the screen of a pc or workstation, and connects them with wires and busses.

The design is taking place on two levels. At the visual level the designer is creating a visual

Fig. 2. This is the schematic of the decoder at the top left corner of Fig. 1. Showing this much detail on the main diagram would make the whole difficult to interpret.

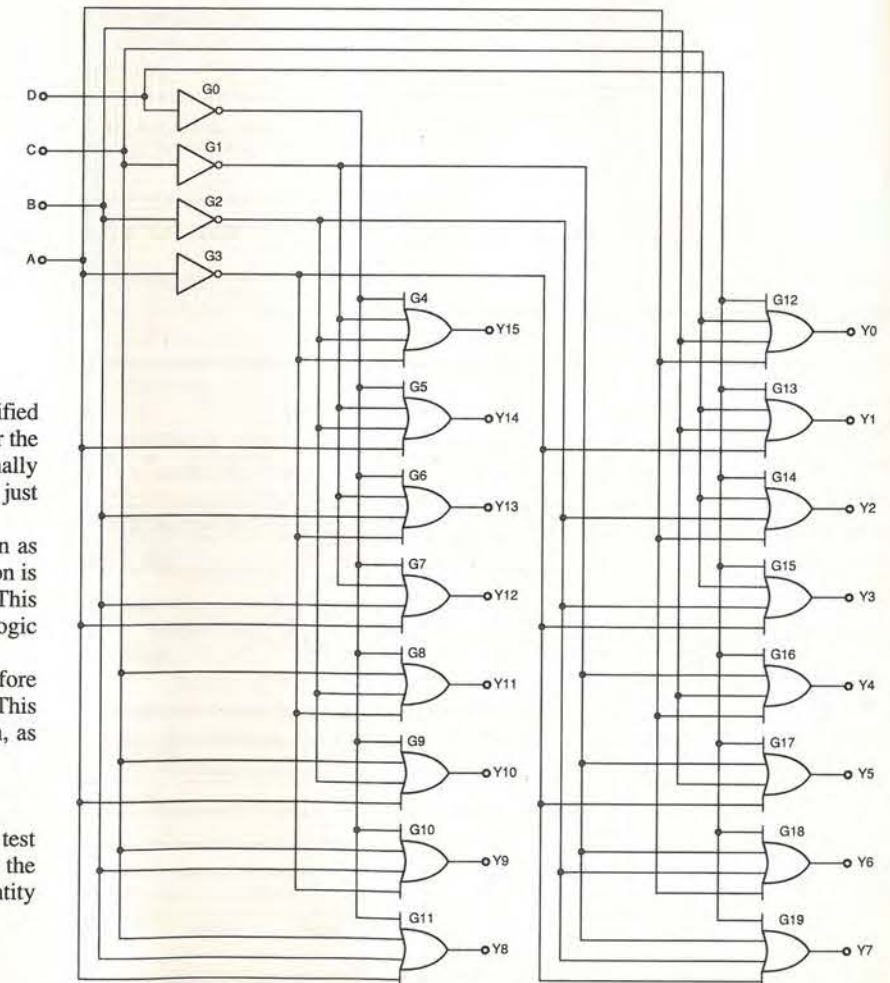

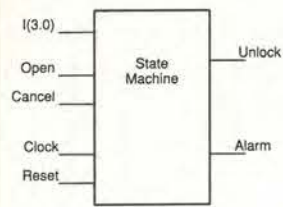

Fig. 3. State machine symbol providing an overview of the combination lock function.

representation of the logic which he requires, in terms of familiar symbols for the components. At a level below this is a net list which defines the location of each component on the screen, and the way it is connected to the other components in the design.

Hierarchical design is still possible, indeed necessary, for all but the simplest of circuits. This can be illustrated via the door lock function used previously.

Figure 1 shows how the state machine may be drawn up. This schematic was created using Viewlogic with the Actel cell library, but a similar result would be obtained with other capture packages and manufacturer's libraries.

The schematic may be broken into four parts which just fit on to a single sheet of the capture display. On the left is a decoder. This is a standard Actel macro and generates the individual number inputs from the four-bit input line. The decoder schematic can be seen at a lower level of hierarchy; there is no need to draw the gate-level function on this sheet as the function of the block is clear. Replacing the symbol with the gate schematic, as in Fig. 2, would make the picture less clear.

Note that the outputs from the decoder have been labelled IN1, IN4, etc., to indicate the number being input; note also that they are active low.

A second decoder on the right-hand side generates signals

to indicate the present state of the state machine. These are labelled S0, S1, S2, etc., to correspond to the state numbering already used.

These signals are also active-low. Although the decoder function was pre-defined, by using it twice it only needs defining once. As a general point, any block of circuitry which is used in more than one location need only be defined once, but used in as many locations as desired.

Outputs from the state machine are generated from the state signals on the right-hand side of the drawing. The block of gates in the middle of the schematic form the combinatorial section, defining the jump conditions from each state. They have been arranged to generate a 'next state' signal for each state. The jump to S0 is, in fact, superfluous since the state register is fabricated from D-types which set low in the absence of an input when clocked. It is included in our schematic for completeness although it would be automatically excluded at the place and route stage when components with 'dangling outputs' are eliminated.

Because the input and state signals are active-low, most of the gate inputs are 'bubbled'. Although a NOR gate with inverting inputs is logically equivalent to an AND gate, the bubbled input gates are used for clarity. For example, the top function says that state S1 is entered when a '6' is input in either state S0 or S1 - the hold condition.

List 2. With VHDL, in order to simulate a design, a test bench needs to be created. This example is for a combination lock.

```
architecture TEST_BENCH of TEST DOOR_LOCK is
    signal CLOCK: Std_Ulogic := '1'; -- defines '1' as
    --the initial level
    signal RESET: Std_Ulogic := '0';
    signal OPEN: Std_Ulogic := '0';
    signal CANCEL: Std_Ulogic := '0';
    signal I: Std_Ulogic_Vector (3 down to 0) := '1111';
    signal DOOR: Std_Ulogic;
    signal ALARM: Std_Ulogic;
    constant CLK_PD: Time := 100ns;
    constant RST_PD: Time := 50ns;
    --Std_Ulogic type of signal allows bit definitions
    --such as 'undefined'
    --'don't care', and 'tri-state' as well as '0'
    --and '1', and give more information
    --in a simulation result.
    component DOOR_LOCK
        port (
            CLOCK: in Std_Ulogic;
            RESET: in Std_Ulogic;
            OPEN: in Std_Ulogic;
            CANCEL: in Std_Ulogic;
            I: in Std_Ulogic_Vector (3 downto 0);
            DOOR: out Std_Ulogic;
            ALARM: out Std_Ulogic
        );
    end component;
begin
    DOOR_LOCK
        port map (
            CLOCK->CLOCK, --explicitly maps a
            --signal to a port
            .
            .
            .
        );
    TB: BLOCK
        begin
            CLOCK <= not (CLOCK) after CLK_PD/2; --defines
            --10MHz clock
            RESET <= '1' after RST_PD;
            I <= 6 after 1µs, 15 after 2µs,
            7 after 3µs, 15 after 4µs, 1 after 5µs -- etc.
            .
            .
            .
        end BLOCK TB;
```

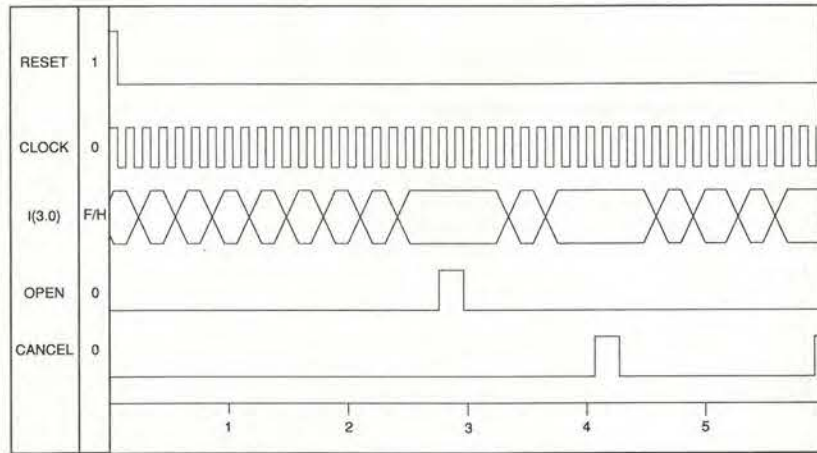

Fig. 4. Waveforms involved in the combination lock system.

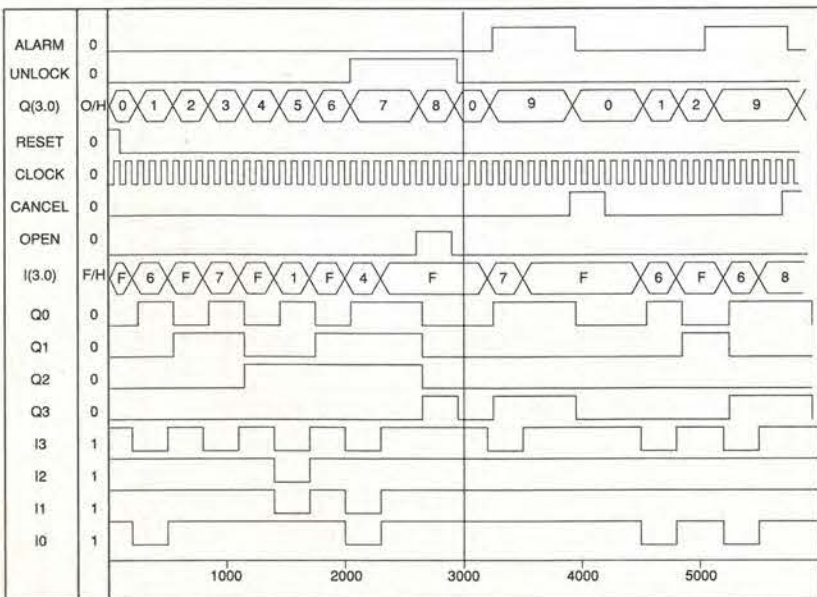

Fig. 5. Display of simulation results for the combination lock detection system.

List 3. Part of the net list for the combination lock illustrates the structure used to store the design information.

```
DEF DOORLOCK; IN3, CANCEL, OPEN, IN0,
    CLOCK, RESET, IN2, IN1,
    UNLOCK, ALARM.
USE ADLIB: INBUF; $1I6.
USE ADLIB: INBUF; $1I5.
USE ADLIB: OUTBUF; $1I11.
USE ADLIB: INBUF; $1I9.
USE ADLIB: INBUF; $1I8.
USE ADLIB: INBUF; $1I7.
USE ADLIB: INBUF; $1I3.
USE ADLIB: CLKBUF; $1I10.
USE ADLIB: INBUF; $1I4.
USE ST_MACH; $1I2.
USE ADLIB: OUTBUF; $1I12.
NET $1N13; $1I11:D, $1I2 :UNLOCK.
NET $1N15; $1I2:ALARM, $1I12:D.
NET $1N22; $1I2:OPEN, $1I7:Y.
NET $1N24; $1I2:CANCEL, $1I8:Y.
NET $1N26; $1I2:RESET, $1I9:Y.
NET $1N28; $1I2:CLOCK, $1I10:Y.
NET ALARM; ALARM, $1I12:PAD.
NET CANCEL; CANCEL, $1I8:PAD.
NET CLOCK; CLOCK, $1I10:PAD.
NET IO; $1I2:IO, $1I6:Y.
NET I1; $1I2:I1, $1I5:Y.
NET I2; $1I2:I2, $1I4:Y.
NET I3; $1I2:I3, $1I3:Y.
NET IN0; IN0, $1I16:PAD.
NET IN1; IN1, $1I5:PAD.
NET IN2; IN2, $1I4:PAD.
NET IN3; IN3, $1I3:PAD.
NET OPEN; OPEN, $1I7:PAD.
NET RESET; RESET, $1I9:PAD.
NET UNLOCK; UNLOCK, $1I11:PAD.
END.
```

The gate inputs are all labelled with the appropriate signal names. Connections do not have to be made with actual wires on the screen; if two nets are labelled with the same name they will automatically be connected in the net list. The converse is also true; wires which must not be connected must have different names. Thus 'S1' has been used for a present state output but 'SS1' for a next state input.

The final section of the state machine is the state register and encoder. A full priority encoder is not needed to drive the state register because, if the logic is designed correctly, only one next state signal is active at any one time. Thus Q3 of the register must be set high by SS8 or SS9, Q2 by SS4, SS5, SS6 or SS7 and so on.

The schematic was generated in the order in which it was described, except that a symbol was created first. This is shown in Fig. 3, and could be used to define the state machine in a higher level of hierarchy; possibly, it could be incorporated into a single fpga with a keyboard encoder, to form a complete system.

Part of the net list is shown in List 3: this is not intended to convey any information, except as an example of the structure used in saving the design information, and to show that while the drawing serves as a primary human interface, the net list is in a form easily read by a computer.

Generating and simulating waveforms

Having constructed a logic circuit on paper, it is necessary to show that it fulfils the desired function.

Just as the circuit was drawn on the screen, at the same time generating an underlying net list, so a set of test waveforms in 'oscilloscope format' can be constructed. Simultaneously, a command file to drive the simulator can be produced. Figure 4 shows the door combination lock.

First, a 10MHz clock is generated, together with the power-on reset to initialise the circuit to state S0. Input starts at 'F'; changing it to '6' should change it to S1, and stay in S1 until

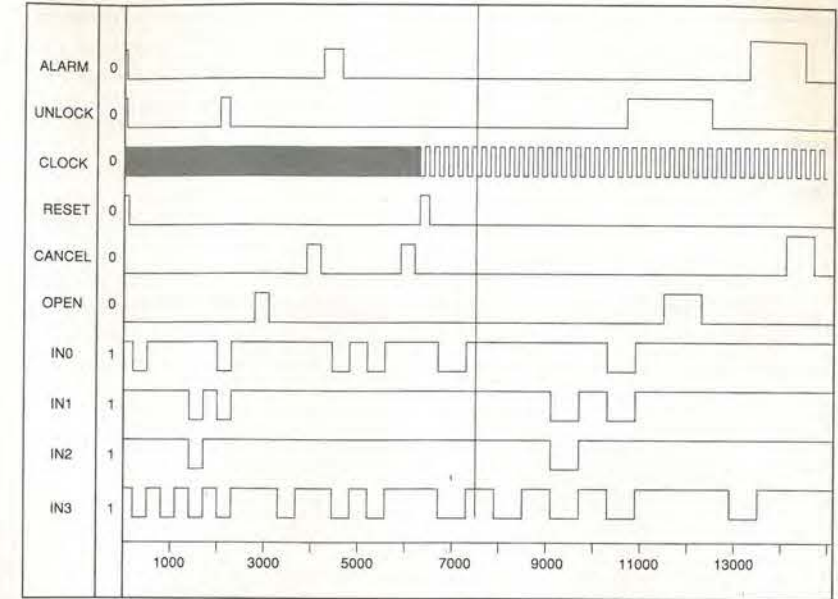

Fig. 6. Post-layout simulation of the combination lock detector. Until the clock is slowed to 5MHz, just to the left of the centre line, the circuit does not function properly.

the input changes back to 'F'. The sequence should run through the states until the door is unlocked, then simulate the door opening and closing, and finally return to S0.

Changing the input to '7' should set the alarm, in state S9, returning to state S0 on activating CANCEL. You can then go on and simulate any number of wrong entries - only one more is illustrated - to prove the complete functionality of the circuit.

The waveform may also be defined in a command file and checks included to ensure that the circuit operates as intended. The format for this is:

```
vector INPUT I[3:0]
| this defines the signals forming the input
vector
vector STATES Q[3:0]
| this defines the state outputs
vector SIGNALSIN RESET OPEN CANCEL INPUT
vector SIGNALSOUT UNLOCK ALARM STATES
| initialize the system
restart
wave DOORLOCK.WFM clock input states
    signalsin signalsout
| this defines the signals for display
wfm CLOCK 0=0 (500=1 500=0) *60
| this defines 60 cycles of 10MHz clock
(500x0.1ns LOW, 500x0.1ns HIGH)
break CLOCK 0 do (assign SIGNALSIN<APPLIED;
+check SIGNALSOUT < TESTPATT)
sim 60000
```

We then have to set up the applied vector pattern in file 'APPLIED' and the test pattern in file 'TESTPATT'. These will be as follows for APPLIED:

```
4F\h
0F\h
06\h
06\h
0F\h, etc.
```

and for TESTPATT:

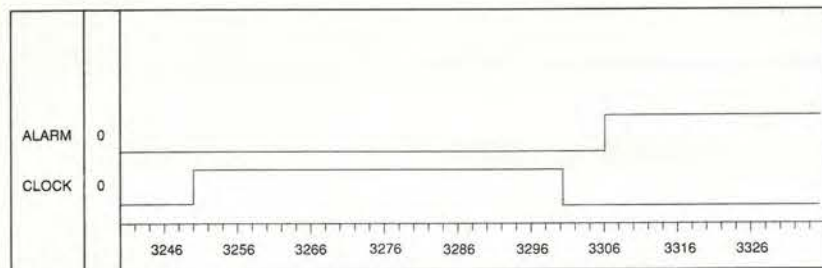

Fig. 7. Exploded section of the simulation Fig. 6 allows detailed examination of timings and delays.

```
>00\h
00\h
00\h
01\h
01\h
02\h...
```

Figure 5 shows the result of the simulation. The next step is to assemble the logic net list into a real device, using the place-and-route program. Estimated timings may now be inserted into the net list and the circuit resimulated to gauge its probable performance. In our case the circuit does not behave properly, however, if we slow the clock to 5MHz as in the right-hand part of Fig. 6, correct operation is restored. It appears that the circuit delays prove too great for the 100ns clock period.

By zooming into part of the waveform we can obtain a good estimate of real circuit delays. Figure 7 shows the

delay between the active clock edge and the alarm output; you can see that this is about 56ns, for four logic levels plus input and output buffer. As the loop round the state machine is between six and nine levels deep, it is possible for problems to arise with a 100ns clock period.

In summary

Various methods exist for defining the logic for fpgas. Schematic capture is probably the most popular because this has been promoted by both device manufacturers and software providers. It also produces an output which looks most like a designer's mental picture of a logic system.

VHDL is derived from logic equation/state equation entry, which was the standard method of defining logic for 20/24-pin plds. However, it has a syntax which is closer to a software programming language so it should be easy to migrate from software to hardware design. It also has the benefit of being a universal language which is not targeted at any particular device manufacturer or product.

Both approaches have the capability of fitting a top-down design hierarchy. Both also allow for individual testing of the component modules before they are connected into a final structure. Most design systems cater for a mixed design approach, where some parts of the system may be defined in VHDL, the entities then being represented by symbols which can be connected together in a top-level schematic.

Whichever approach is used, the basic pattern is the same - logic entry, then logic simulation, followed by device definition and logic synthesis. Once the chip is laid out and routed, the estimated delays can be back annotated to the simulation and real performance forecast. Proper use of the design tools leads to a solution which meets the original design specification. ■

ANCHOR SUPPLIES Ltd

The Cattle Market Depot
Nottingham NG2 3GY. UK

Telephone: +44 (0115) 986 4902/
+44 (0115) 986 4041 24hr answerphone
Fax: +44 (0115) 986 4667



NEW LOWER PRICES

Micro Video Cameras

NEW LOWER PRICES

Following our recent Readers Offer for the 721-S Micro Camera many readers have contacted us asking about

other items in our range of Micro Cameras and Security Surveillance equipment.

We are SOLE AUTHORISED IMPORTERS of the entire range of Cameras and Video Surveillance equipment produced by the world's leading manufacturer. ALL items in the range carry a full 12 Months Guarantee.

If you would like to receive our comprehensive catalogue of Cameras and associated equipment please send a large SAE with 48p postage, marked "Camera Catalogue"

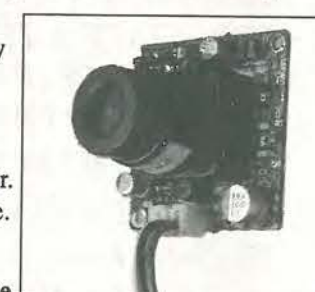
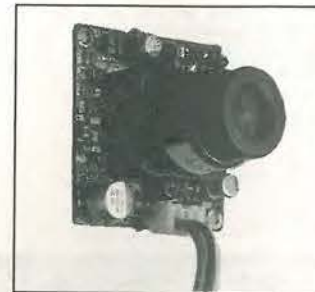

Here is a sample of the available stock.

A-721-S Micro Camera 32mm x 32mm ... £85 A-721-P Micro PIN-HOLE Camera ... 32mm x 32mm ... £85
A-921-S Camera with AUDIO ... 30mm x 30mm ... £95
A-1211 C/CS Mount Camera ... 110mm x 60mm x 60mm ... £110
A-521 Micro Cased Camera 43mm x 48mm x 58mm ... metal cased ... £120
6001-A High Resolution COLOUR Cameras (420 lines) ... 0.45 lux ... £210
Outdoor Camera Housings ... Aluminium ... £35 Camera Mounting Brackets ... Universal Mounting ... £5.95
Camera Switchers ... for up to 8 Cameras ... £75

NEW MODEL Auto Record Controllers ... Infra Red Controller using "One For All" technology controls your STANDARD VHS Video, and allows you to make unattended recordings of intruders etc. Accepts Normally open or Normally Closed contact inputs. Self contained unit ... Turns your

VHS recorder into a professional Security Recorder ONLY ... £85
QUAD-1 B/W Multivision Processor ... 4 pictures on one screen/video ... Including 4 channel switcher ... NOW ONLY £249

QUAD-2 COLOUR Multi Vision processor, REAL TIME ... including 4 channel switcher ... 4 Pictures on one screen/video ... NOW ONLY £575.
QUAD-3 COLOUR Multi Vision Processor, REAL TIME ... with On screen Titles and Time/Date information ... Including 4 channel switcher ... 4 Pictures on one screen/video ... NOW ONLY £695.

SCI ... SCANNER ... 350° PAN ... Automatic / Manual ... £105
IRI-1 Infra Red Illuminator ... 12V operation ... 60 degree illumination angle to 20m. For "Total Darkness Surveillance" ... NOW ONLY £85.
VMS-1 .. Video Motion Sensor ... replaced alarm sensors with totally electronic video monitoring system that detects changes in the video signal .. £175
C/CS Format lenses ... Premium 3.6mm = £22.50 Superior 8mm = £27.50

PLEASE NOTE:

SPECIAL OFFER

New and Boxed 14" COLOUR MONITORS..Models 1412 24V DC operation @ 2.2A..Twin Composite Video Inputs (75ohm BNC) Black steel case...Supplied with a pair of trailing leads for DC connections. Very easy to convert to 240V operation by adding a 240V / 24V supply either internally or externally. 30 Day Warranty.

NEW CONDITION

Circuit Diagram available..request at time of ordering
NOW ONLY £99.00 INCL VAT
Courier delivery to UK addresses = £12.25)

VHS Video Players...Front Loading VHS Decks..12V operation. Rear Panel 2.6mm DC socket for power. Play..FF..RW..Stop Controls with the addition of REPEAT facility which allows the tape to be rewound and replayed time and time again. Video / Audio Outputs via Phono Sockets

AS-NEW Condition..
NOW ONLY £50.00 INCL VAT
(Courier delivery to UK addresses = £8.75)

OPEN 6 DAYS A WEEK

Mon-Fri 9am-6pm Sat 8am-4pm

NO APPOINTMENTS NEEDED. CALLERS ALWAYS WELCOME
NATIONAL AND INTERNATIONAL MAIL ORDER A SPECIALITY

ALL PRICES INCLUDE VAT (AT 17.5%) and COURIER DELIVERY UNLESS OTHERWISE STATED



Radio Receiver Trainer

An Invaluable Learning and Design Tool for all Experimenters

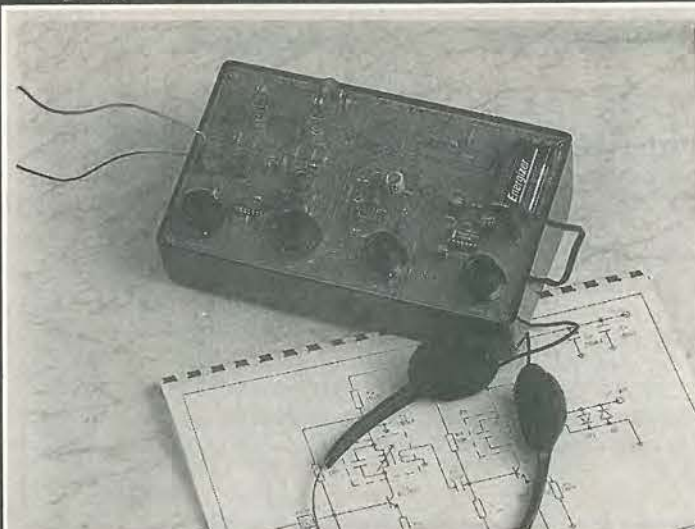

The manual contains complete schematics and theory of operation of all the building blocks. Use this trainer to receive frequencies from 500KHz to 110MHz!

A set of proven alternate building block designs are included in the manual for you to get started with your own designs. There is no need to get your complete receiver design working all at once. Build and test each block one at a time.

The Radio Receiver Trainer contains nine receiver building blocks and a comprehensive training manual.

Simply connect the building blocks to build AM, SW, Superhet and Direct Conversion receivers. Decode SSB, CW & FM! Use proven building blocks to develop and test your own designs.

Full technical support and advice given.

Pricing: Complete £129.00
Kit £89.00
(Kit excludes case & headphones)
P&P is £5 (UK), £8 (EC), £12 (World)
Add 17.5% Vat to Total Price

Building Blocks: RF Input Tuner
RF Oscillator
Mixer
IF Filter
IF Amplifier
AM Detector
Beat Frequency Oscillator
Audio Filter
Audio Amplifier

Mail Order To: Pyramid Electronics Ltd.

204 Ferndale Road, Brixton, London SW9 8AG

Phone (0171) 738-4044

Fax (0171) 274-7997. Out of office ordering by answering machine.



ARTICLES WANTED

WE WANT TO BUY!!

IN VIEW OF THE EXTREMELY RAPID CHANGE TAKING PLACE IN THE ELECTRONICS INDUSTRY, LARGE QUANTITIES OF COMPONENTS BECOME REDUNDANT. WE ARE CASH PURCHASERS OF SUCH MATERIALS AND WOULD APPRECIATE A TELEPHONE CALL OR A LIST IF AVAILABLE. WE PAY TOP PRICES AND COLLECT.

R. HENSON LTD.

21 Lodge Lane, N.Finchley, London N12 8JG.

5 Mins, from Tally Ho Corner.

TELEPHONE

0181-445-2713/0749

FAX 0181-445-5702

TOP PRICES PAID

For all your valves, tubes, semi conductors and IC's.

Langrex Supplies Limited
1 Mayo Road, Croydon
Surrey CR0 2QP

TEL: 0181-684 1166
FAX: 0181-684 3056

Wandel Goltermann

PRA.1, 2mbit Frame
Mux Analyzer superb
instrument.

£3,500 o.n.o.

Tel: 01566 781680

★★WANTED★★

Test equipment, Electronic Scrap, Valves, Transmitters/Receivers, Factory & Warehouse Clearance. Confidentiality Assured.

TELFORD ELECTRONICS

Phone: 01952 605451
Fax: 01952 677978

RF DESIGN SERVICES

All aspects of RF hardware development considered from concept to production.

WATERBEACH ELECTRONICS

TEL: 01223 862550
FAX: 01223 440853

VALVES, and CRTs AVAILABLE

ONE MILLION VALVES stocked for Audio, Receiving, Transmitting & RF Heating. Rare brands such as Mullard & GEC available. Also MAGNETRONS, KLYSTRONS, CRTs and SOCKETS.

Large stocks of Russian & Sovtek items.

Please ask for our free catalogues of valves or CRTs.

VALVES, etc. WANTED

Most types considered but especially KT88 (£48), PX4/PX25 (£50), KT66 (£35), KT77 (£15), EL34 (£10), EL37 (£9), ECC83 (£3). Valves must be UK manufacture to achieve prices mentioned. Also various valve-era equipment e.g. Garrard 301, (up to) £80. Ask for a free copy of our wanted List.

BILLINGTON EXPORT LTD., Billingshurst, Sussex RH14 9EZ.
Tel: 01403 784961 Fax: 01403 783519

VISITORS STRICTLY BY APPOINTMENT. MINIMUM ORDER £50 plus VAT

ARTICLES FOR SALE



Protect Your Microchips from STATIC DISCHARGE!

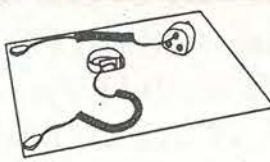

Use an SSE grounding kit.

Kit includes:

- static dissipative solder resistant rubber mat.
- wrist strap
- ground lead
- earth plug

Mat size 70 x 30 cm - offer price £16.55 per kit + VAT - Ref: AGK1
Mat size 25 x 20 cm - offer price £12.55 per kit + VAT - Ref: AGK2

STATIC SAFE ENVIRONMENTS
127 Hagley Road, Birmingham B16 8XU
Tel: 0121 454 8238 Fax: 0121 625 2275

Payment by CHEQUE / ACCESS
VISA / MASTERCARD
Catalogue available

Marconi Spectrum Analyser model 2382, 100Hz-400MHz, 3Hz min RBW

With tracking generator and GPIB, new Marconi service manuals and fresh calibration.

£4000

Also HP7475A A3 plotter with GPIB interface

£500

Tel: 0118 979 2340

QUAD ESL's For sale 1pr only, offers to Mike. Phone/Fax: 01483 487189.

DRANETZ PHASEMETER For sale, very accurate 0.01" from 2Hz to 700 KHz. Two only £200 ono. Phone/Fax: 01483 487189.

RECRUITMENT



Electronics is moving fast

Are you up to speed?

This innovative programme offers companies and individuals the opportunity to keep right up to speed on developments in microelectronics design without having to lose time at work.

No matter what your location the course will come to you via a high spec PC, connected to teaching resources and a host of other facilities, via your own high speed data link. Making a connection with this tele-learning programme will mean you can study from home when it suits you.

The programme is approved under the Integrated Graduate Development Scheme and has been developed with considerable input from industrialists.

For more information contact:

Roy Attwood, IGDS Co-ordinator, Bolton Institute
Deane Road, Bolton, Lancs BL3 5AB

Tel. (01204) 528851/900600 Ext 3667

Fax. (01204) 370916

E-mail: r.attwood@bolton.ac.uk

MSc Advanced Microelectronics for Industrialists

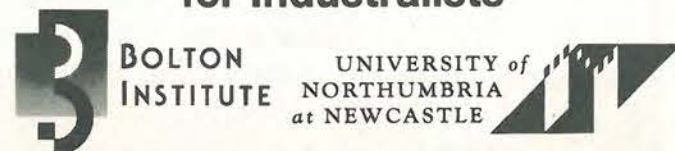

Providing Access to Flexible Study Programmes

CLASSIFIED

TEL 0181 652 3620

FAX 0181 652 8956

ARTICLES FOR SALE



SUPPLIER OF QUALITY USED TEST INSTRUMENTS



CONTACT

Cooke International

ELECTRONIC TEST & MEASURING INSTRUMENTS
Unit Four, Fordingbridge Site, Main Road, Barnham,
Bognor Regis, West Sussex, PO22 0HD, U.K.
Tel: (+44)01243 545111/2 Fax: (+44)01243 542457

CIRCLE NO. 140 ON REPLY CARD



OPERATING & SERVICE MANUALS

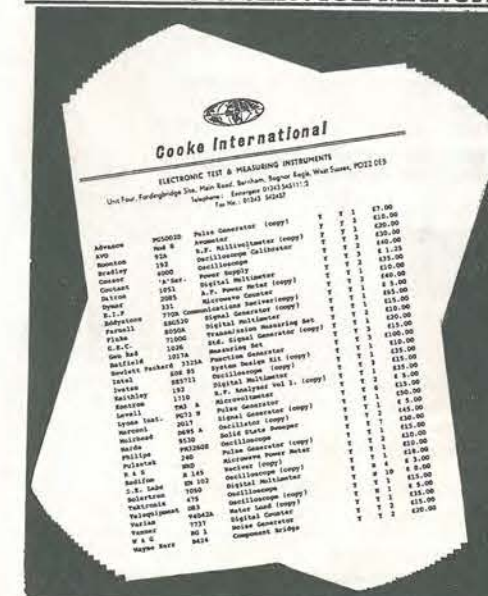

CONTACT

Cooke International

Unit Four, Fordingbridge Site, Main Road, Barnham,
Bognor Regis, West Sussex, PO22 0HD, U.K.
Tel: (+44)01243 545111/2 Fax: (+44)01243 542457
NOW AVAILABLE CATALOGUE ON DISC

CIRCLE NO. 141 ON REPLY CARD

ADVERTISERS INDEX

Anchor	526	Labcenter	506
Antrim	503	Leading Edge	479
Bull Electrical	445, 517	M & B	461
CMS	479	Number One Systems	492
Card Professionals	479	Olson	IFC
Compass	465, 496	Pico Technology	462, 519
Conford	455	Quickroute	455, 464
Display Electronics	501	Ralfe Electronics	529
Equinox	IBC	Stewarts of Reading	503
Field	465	Surrey Electrical	453
Halcyon	496	TTI	465
Hart	447	Technology	453
Hitex	496	Telnet	442
ICE Technology	OBC	Telford	485
IOSIS	455	Tie Pie	442
JPG	453	Ultimate	451
John's Radio	475	Wood & Douglas	503
Keytronics	494		

SPECTRUM ANALYSERS



ADVANTEST TR4132 100kHz-1GHz £2500
 ANRITSU MS420B 10Hz-30MHz network/spectrum analyser 75 ohms £3000
 AVCOM - portable, battery operated, to 1000MHz £2000
 TEKTRONIX 492 21GHz portable spectrum analyser, with options 1, 2 and 3 £6500 or £7500 with multiplexor and mixers to 40GHz
 IFR A7550 portable 1GHz synthesized, with tracking generator £4000
 ADVANTEST TR4135 10kHz-3.6GHz synthesized, with tracking generator £6000
 HP8702B lightwave component analyser £10000 (options 006/011) 6GHz
 HP8575A/182T 350MHz £1500
 HP8591A 1.8GHz portable, 75ohm option 1 £4250

MARCONI INSTRUMENTS



2019A synthesized AM/FM signal gen 80kHz-1040MHz £2000
 2091C/2902C white noise test set, pair £500
 2305 modulation meter £2500
 2955 radio communications test set with 2960 cellular adapter £3250
 6460/6421 power meter & sensor 10MHz-12.4GHz £350
 65xx waveguide detectors for use with 6501/2-scalar analysers £350
 6055, 6056, 6057, 6059 signal sources each £250

ralfe electronics exclusively professional T&CM ©
 • 36 Eastcote Lane • South Harrow • Middx HA2 8DB • England •
 TEL (+44) 0181-422 3593 • FAX (+44) 0181-423 4009

EST 41 YRS



DISTRIBUZIONE E ASSISTENZA, ITALY: TLC RADIO, ROMA (06) 871 90254

TEST EQUIPMENT

★ URGENTLY REQUIRED ★

HEWLETT PACKARD 8720 series network analysers £20,000+paid for 'C'
 HEWLETT PACKARD 8510 series microwave analysers, anything considered
 HEWLETT PACKARD 8566B series spectrum analysers £10K-£20K paid
 HP8753C+ vector network analysers, we'll pay over going rate for late issue.
 Guaranteed top prices paid for all current model spectrum/network analysis.



ISO9002 ACCREDITED STOCKIST MEASUREMENT & TEST EQUIPMENT

ADRET 740A synthesized signal generator 0.1-1120MHz £2000
 BRUEL & KJAER 2317 portable level recorder £1500
 FARNELL SSG2000 synthesized signal generator 10Hz-2000MHz £2000
 PHILIPS PM5193 synthesized function generator £2000
 SCHLUMBERGER 7081 precision voltmeter 8.5 digits £2000
 WANDEL & GOLTERMANN PJM-4S jitter meter £5000
 WAVETEK 1080 1-1000 sweep generator £1250
 WAYNE KERR 3245 precision inductance analyser £3000

HEWLETT PACKARD



1640B serial data generator £500
 11581A attenuator set £350
 3336A synthesizer/level generator £2000
 3235A switch/test unit £1000
 3325A synthesized function generator /01/02 £1500
 33320G/33322G programmable attenuators 4GHz, with driver 11713A £1000
 As above but 18GHz set £1500
 35650A mainframe £2000
 E3615A bench power supply £175
 37724A/04 digital hierarchy test set £9500
 37900D signalling test set with 2 x 37915A interface cards £5500
 4140B pA/meter, DC voltage source £4000
 4275A multi-frequency lcr meter £3000
 4093B protocol tester base (PT300) £3500
 5386A 3GHz frequency counter £1500
 545100A 1GHz digitizing oscilloscope, now inc 2 x 1GHz active probes £1500
 54620A logic analyser £1200
 75000-series B VXI controller £1000
 8018A serial data generator £1000
 8082A pulse generator 250MHz £2000
 8111A pulse generator 20MHz £1250
 83411C lightwave receiver 1300/1550nm £1750
 83440C lightwave detector 20GHz 1300/1550nm £2000
 86222A/8620C 10MHz-2.4GHz sweep generator £2000
 8660B signal generator 1300MHz £1500
 8702B lightwave component analyser £10000
 87510A gain-phase analyser 100kHz-300MHz £6500
 8901B modulation analyser £5000
 J2215A FDDI portable multimode test set £1500
 J2304 internet advisor with ethernet interface £2500

SEND FOR LATEST STOCK LIST. WE FAX LISTS AND SHIP WORLDWIDE. ALL FULLY LAB-TESTED AND NO-QUIBBLE GUARANTEED

CIRCLE NO. 142 ON REPLY CARD

ELECTRONIC UPDATE

Contact Malcolm Wells on 0181-652 3620

A regular advertising feature enabling readers to obtain more information on companies' products or services.

A world of colour LCD

The widest range of colour LCDs, LCD monitors and plug and play kits available in the UK, all in one easy to use brochure, is now available FREE!

It includes products ranging from 2.9" monitors to 16.1" colour LCD screens, mono/colour STN TFTs and touch screen technology from the worlds leading manufacturers.

Phone Trident today for your free copy.
 Tel: 01737 765900
 Fax: 01737 771908

CIRCLE NO. 143 ON REPLY CARD

Comprehensive new LCD brochure

The widest range of colour LCDs, LCD monitors and plug and play kits available in the UK, all in one easy to use brochure, is now available FREE!

It includes products ranging from 2.9" monitors to 16.1" colour LCD screens, mono/colour STN TFTs and touch screen technology from the worlds leading manufacturers.

Phone Trident today for your free copy.
 Tel: 01737 765900
 Fax: 01737 771908

CIRCLE NO. 143 ON REPLY CARD

DAQ Designer 97

Call National Instruments for your free copy on (01635) 523545

CIRCLE NO. 144 ON REPLY CARD

New for '97 Free Data Acquisition Software Tool

DAQ Designer 97 is a free system configuration software tool for the PC that takes you through your application step-by-step, asking you questions, and recommending all the right equipment, including: PC plug-in DAQ boards, PCMCIA DAQ cards, Signal Conditioning and Sensor Interfacing, Cabling and Software.

Call National Instruments for your free copy on (01635) 523545

CIRCLE NO. 144 ON REPLY CARD

Feedback TEST & MEASUREMENT

Over 800 products from the worlds leading manufacturers

For friendly service & fast delivery phone Feedback

CIRCLE NO. 145 ON REPLY CARD

NEW Feedback T&M Catalogue

The latest edition of the Feedback Test & Measurement catalogue is now available. Over 60 pages packed with more than 800 products divided into over 20 sections. The catalogue is indexed for both product and manufacturer and is fully illustrated. Whether you are looking for an individual product, a complete workstation, or a solution to a particular Test & Measurement need the NEW Feedback catalogue will solve your problems, send for a copy NOW!

CIRCLE NO. 145 ON REPLY CARD

JENSEN

World Leader in Tool Kits

CIRCLE NO. 146 ON REPLY CARD

NEW JENSEN TOOLS CATALOGUE

Colourful new Catalogue, hot off the press from Jensen Tools, presents unique new tool kits for service/support of communications equipment. Also latest test equipment from many major manufacturers. Includes hard-to-find tools, PC/LAN diagnostics, bench accessories, static control, technical manuals and more.

Ring 0800 833246 or Fax 01604 785573 for a free copy.
 Jensen Tools, 10-12 Ravens Way, Northampton NN3 9UD

CIRCLE NO. 146 ON REPLY CARD

"THE COMPLETE PROGRAMMING SOLUTION FOR 8051 MICROCONTROLLERS & MUCH MORE"

MICRO-PRO THE STATE-OF-THE-ART PROGRAMMER

NOW SUPPORTS AVR MICROCONTROLLER FAMILY

UNLOCK NEW LIBRARIES

Features Include

- Micro-Pro for Windows™ Programmer Interface Software
- FPGA hardware ensures future device support
- Supports most DIL devices up to 40 pins without an adaptor
- Adaptors available for many other package types

Order code: MPW-SYS £149.00 ▲

Atmel - 89C, 89S (see table below)
 Philips/Intel - 87C51/52-Fx
 Dallas - 87C520
 Comes as standard

Atmel E² - 24C, 25C, 28C, 59C, 93C
 FLASH - 29C, 49F
 Order Code: MPW-LIB MEM AT £75.00

FPGA Serial Configurators
 Atmel, Xilinx, Altera etc.
 Order Code: MPW-LIB-CON £75.00

A Security Dongle is required for the above libraries Order Code: MPW-LIB-SEC £24.00

The **Atmel** 8051 FLASH microcontroller family

Atmel Part Code	89C51	89C52	89C55	89S8252	89S53	89C1051	89C2051
Flash Code ROM (bytes)	4K	8K	20K	8K	12K	1K	2K
RAM (bytes)	128	256	256	256	256	64	128
EEPROM	-	-	-	2K	-	-	-
In-system re-programmable	-	-	-	YES	YES	-	-
I/O Pins	32	32	32	32	32	15	15
16-bit Timer/Counters	2	3	3	3	3	1	2
Watchdog timer	-	-	-	YES	YES	-	-
Interrupt sources	6	8	8	9	9	3	6
Serial UART (full duplex)	YES	YES	YES	YES	YES	-	YES
SPI Interface	-	-	-	YES	YES	-	-
Analogue comparator	-	-	-	-	-	YES	YES
Data pointers	1	1	1	2	2	1	1
Package Pins (DIL)	40	40	40	40	40	20	20

C51 Microcontroller Starter System

UPGRADE to 8K NOW AVAILABLE

- Optimising C Compiler
- Macro Assembler
- Software Simulator
- Device Programmer
- Evaluation Module
- Atmel AT89C2051
- Hardware/Software Documentation

Plus FREE Atmel CD ROM data book
 Order code: AT-89C-2K-ST £199.00

KEIL SOFTWARE

KEIL Integrated Development Environment - C compiler + Assembler output restricted to 2K total program code.

In-Circuit Parallel Programming Adaptor

Now you can re-program the entire 89C & 89S Atmel Microcontroller families in-circuit

Order code: AD-8051-ICPP £125.00 (Requires Micro-Pro Programmer to operate)

EQUINOX TECHNOLOGIES
 The Embedded Solutions Company

Visit our web page at: www.equinox-tech.com
 Email: sales@equinox-tech.com
 229 Greenmount Lane, Bolton BL1 5JB UK

NEW programmers start at only £295



With prices starting as low as £295, ICE Technology's new range of parallel port programmers offers something for every budget. All programmers support dual in line devices directly in the socket - no adapters or modules are needed for any families of devices, providing extensive device coverage at very affordable prices. The full range of programmers is shown in the panel on the right. Our new easy to use device support checklist will help you to choose the programmer that is right for you, just call or use our faxback for a copy. All programmers come with FREE software updates on our BBS or our ftp site, full technical support direct from the manufacturer and one year's guarantee. All models can run from batteries or mains - ideal for use with laptops.

Low cost EPROM programmer

At only £295, the EPMaster LV is a powerful EPROM programmer which offers so much more than other EPROM programmers. With its 40 pin socket it can support all types of EPROMs including 16 bit wide with no need for additional modules. Serial PROMs, Serial EEPROMs, Flash and EEPROMs are all included in the device support at no extra cost. In addition, low voltage parts are fully supported with the programmer's separate 1.8V, 3.3V and 5V logic circuits. EPMaster LV connects to the parallel port of any PC compatible and can be operated from batteries or mains electricity. You can also add a built in ROM/RAM emulator with a capability of up to 512k by 16, turning the EPMaster LV into a powerful development tool.

Enq No 176

High Speed Gang Programming



The Speedmaster GLV-32 Gang/Set programmer offers simultaneous high speed programming for up to 8 EPROMs and Flash (up to 8Mbit) at 3.3V and 5V. The 3.3V facility ensures that programmed devices will work correctly at their nominal operating voltage. Functions include gang programming, set programming and full editing. The Speedmaster GLV32 works in PC or stand alone mode.

Enq No 177

For details on any of our range of programmers, call or fax us now. You can obtain information immediately by using our faxback service or homepage.
ICE Technology Ltd, Penistone Court, Penistone, South Yorkshire S30 6HG. United Kingdom.
Tel: +44 (0)1226 767404 **Fax:** +44 (0)1226 370434 **Faxback:** +44 (0)1226 761844 **email:** sales@icetech.com
Homepage: <http://www.icetech.com> **BBS:** +44 (0)1226 761181 (14400 baud, 8N1)

Universal programmer only £525

The Speedmaster 1000+ and Micromaster 1000+ offer new levels of affordability in device programming. At only £395, the Speedmaster 1000+ supports all types of memory devices, plus 8748/51, BPROMs, GALs and erasable PALs. The Micromaster 1000+ at just £525 extends this support to include PALs, EPLDs, MACH, MAX, PSDs and over 180 microcontrollers including PIC,

ST6, MC68HC705, MC68HC711, TMS370, TMS320, 87Cxxx, 89Cxxx, COPs etc. The Micromaster 1000+ can support all device types, even Motorola micros, with NO ADAPTERS or MODULES for any dual in line devices up to and including 40 pins. As with all our programmers free software updates are included via BBS or our ftp site.

Enq No 178



LV40 Portable

Reaching the parts other programmers can't reach

The NEW LV40 Portable stands head and shoulders above other portable programmers with its comprehensive device support which includes EPROMs, EEPROMs, Serial PROMs, BPROMs, Flash, NVRAMs, PSDs, PALs, GALs, PEELs, EPLDs, MACH, MAX and over 180 microcontrollers. Unlike other portables, no adapters or modules are needed for any of these devices up to 40 pins dual in line. With socket adapters the LV40 is capable of supporting devices of over 40 pins and other package types.

At £995 for the complete package you'll soon see why the LV40 Portable is the best value, most powerful portable programmer

Enq No 179



£995^{***}

- Portable Universal Programmer
- High speed
- PC software included
- No modules to buy
- Supports memory, programmable logic, high density logic, and over 180 micros.
- Support for 1.8, 3.3 and 5V devices
- Battery or Mains operation
- Lifetime free updates

PROGRAMMER MODELS AND PRICES

LV MODELS (SUPPORT 1.8V, 3.3V and 5V DEVICES)		SPEEDMASTER 1000+	EPROMs, EEPROMs, Flash, NVRAMs, Serial PROMs, Serial EEPROMs, BPROMs, GALs, 8748/51	£395	
EPMASTER LV	EPROMs, EEPROMs, Flash, Serial PROMs, Serial EEPROMs 8 to 40 pins all without adapters. Built in emulator modules: 128k by 8: £395 128k by 16: £465	£295	MICROMASTER 1000+	EPROMs, EEPROMs, NVRAMs, Flash, Serial BPROMs, PALs, GALs, PEELs, MACH, MAX, PSD, over 180 microcontrollers without adapters.	£525
SPEEDMASTER LV	EPROMs, EEPROMs, Flash, NVRAMs, Serial PROMs, Serial EEPROMs, BPROMs, GALs, PALs, EPLDs, MACH, MAX, 8748/51.	£495	SPEEDMASTER GLV32	High speed EPROM/Flash 8 way Gang/Set Programmer. Supports 3.3V and 5V	£645
MICROMASTER LV	EPROMs, EEPROMs, NVRAMs, Flash, Serial, BPROMs, PALs, GALs, PEELs, MACH, MAX, PSD, over 180 microcontrollers without adapters.	£625	COP GANG PROGRAMMER	8 way Gang programmer for National Semiconductor COP family of micros	£1500
LV40 PORTABLE	All devices supported by Micromaster LV, plus completely portable with built in keypad and LCD display.	£995	SOCKET ADAPTERS	for PLCC, TSOP, QFP, SOIC, SSOP etc.	from £65

All prices exclude VAT and delivery



CALL OUR SALES HOTLINE ON 01226 767404 - OR USE OUR FAXBACK FOR FULL DETAILS - 01226 761844

CIRCLE NO. 103 ON REPLY CARD