

2.5GHz frequency meter for less than £100?

ELECTRONICS WORLD

INCORPORATING WIRELESS WORLD

DECEMBER 1997 £2.35

Austria Asch. 66.00
Denmark DKr. 67.00
Germany DM 18.00
Greece Dra. 1100.00
Holland Dfl. 11.75
Italy L. 8800.00
Malta Lm. 1.55
IR £3.30
Singapore S\$7.50
Spain Pts. 850
USA \$5.95

A REED BUSINESS PUBLICATION
SOR DISTRIBUTION

Fuel-saving ignition breakthrough

**Understanding
capacitors**

**MPEG quality
issues**

**New noise
theory**

**Microstrip
made easy**

**Design heat
sinks in
minutes**

**PC i/o for
Windows**

Internet

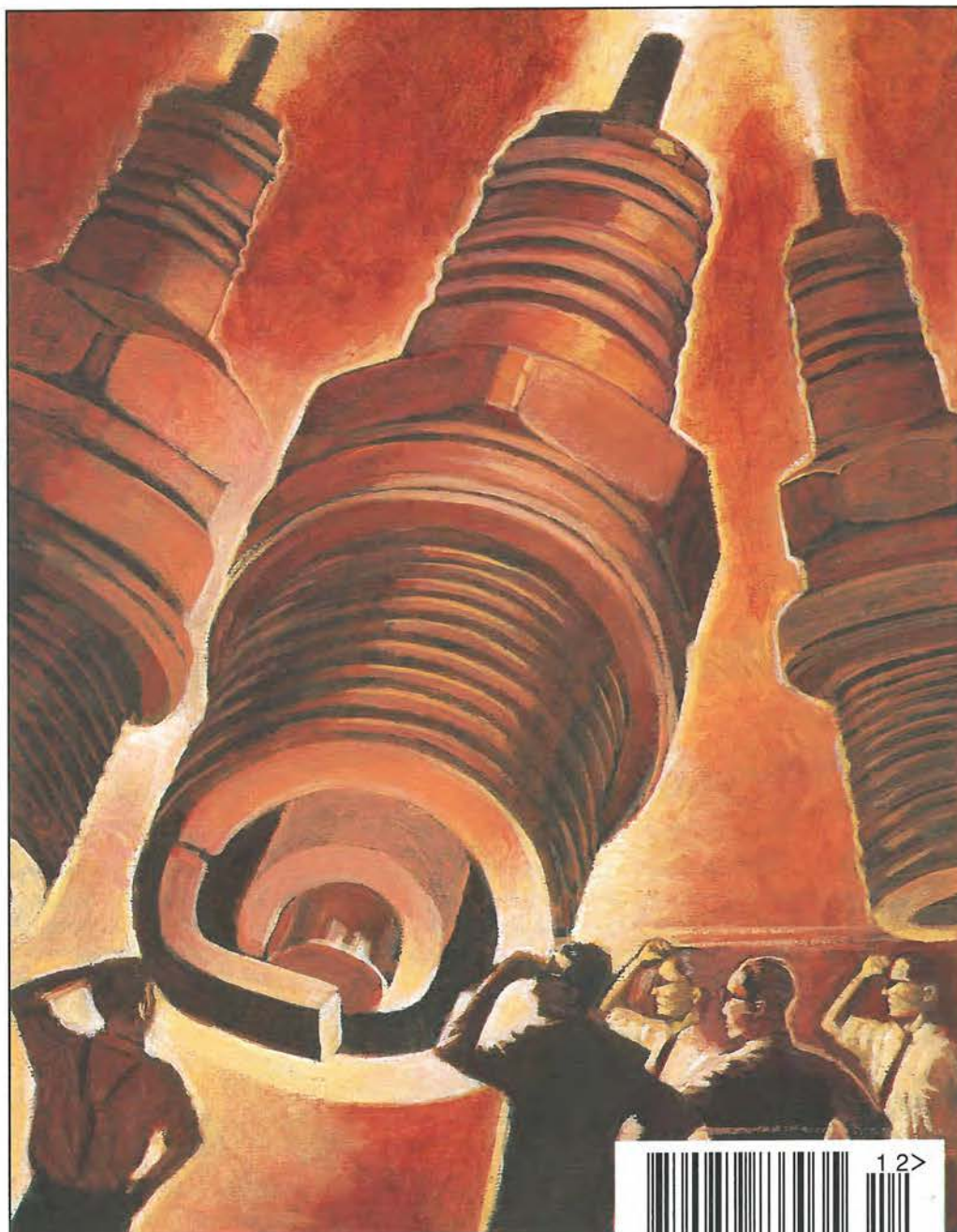

ISDN for all? See page 971



NEW

TINA^{Plus}

The circuit design and analysis package which gives you a great deal more

- More Power
- More Functionality
- More Value for Money



Special introductory offer, just **£199***
 We challenge you to find a better circuit design and analysis package anywhere
*Price excludes V.A.T

- Analogue, digital and mixed mode simulation
- Powerful analysis tools include AC, DC, transient, pole zero, Fourier (series & spectrum), noise, digital step-by-step and digital timing
- Monte Carlo and worst case analysis
- Enhanced symbolic analysis (providing closed form formulas)
- Temperature and parameter stepping, sweeping and optimisation
- Programmable input to circuits
- Component library contains 5,000+ components (user extendible)
- New models, including analogue control elements
- Interactive components
- Faster algorithms for mixed-mode and large circuits
- Improved schematic entry
- Export to popular PCB packages
- Export/import in Spice format
- Display results in sophisticated diagrams or on a range of Analogue and Digital Virtual Instruments, including function generator, multimeter, oscilloscope, frequency analyser and logic analyser
- Comprehensive DTP functions

Try TINA plus for yourself. For free demo disk, contact:
 Tandem Technology Limited Breadbare Barns, Clay Lane, Chichester, West Sussex, PO18 8DJ
 Telephone: 01243 576121 Fax: 01243 576119
 E-mail: 101626.3234@compuserve.com Visit our website: www.tina.com

CIRCLE NO. 102 ON REPLY CARD

Contents

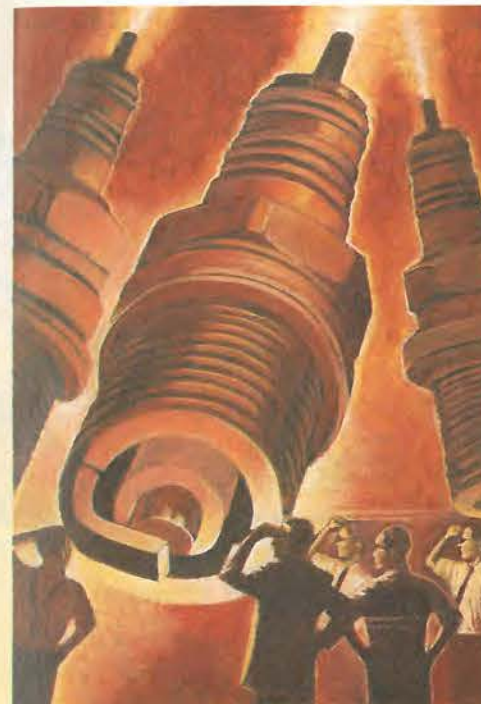

Cover - Hashim Akib

982 BRIGHT SPARKS
 Michael Ward's radically-new ignition system leads to a simpler, cleaner and more efficient petrol engine. And with the anti-pollution laws tightening up world wide, the big boys might just be forced to listen to him.

990 HANDS-ON INTERNET
 Cyril presents tips for speeding up your searches plus news of circuit simulation software to be found on the net.

994 A WINDOW ON ANALOGUE I/O
 Driven via the pc's printer port, Colin Attenborough's 12bit analogue i/o subsystem was designed with Windows control in mind.

998 UNDERSTANDING CAPACITORS
 Most engineers know which type of capacitor to choose for a given job - but do they know why? Cyril Bateman explains.

1005 NEVER MIND THE QUALITY FEEL THE BANDWIDTH
 John Watkinson explains how most movie frame sequences lend themselves to MPEG coding, but others certainly don't.

1013 SEEING THROUGH NOISE II
 Breaking new ground, Patrick May shows how electrons emitted from the surface of a thin metal film equate to 1/f noise.

1017 SPEAKERS' CORNER
 John Watkinson looks at the pitfalls of specifying the most difficult component in the audio chain - the loudspeaker.

1019 MICROSTRIP MADE EASY
 Nick Wheeler shows how designing a microstripline board can be very simple for most applications.

1022 RADIO REFLECTIONS FROM RUSSIA
 One of the world's oldest technical museums, in St Petersburg, holds a wealth of early British wireless equipment, as Khatskel Ioffe explains.

1036 DESIGNER HEAT SINKS
 In six easy steps, Ray Fautley shows you how to find the heat sink area needed to cool a transistor, diode or power resistor.

1045 A BATTERY OF CHARGERS
 Philip Darrington looks at simple single-chip solutions for charging advanced batteries.

Regulars

971 COMMENT
 At last - ISDN for all.

973 NEWS
 Job prospects, \$8 video camera, New PCI bus standard, Doubts over network computer technology, First FireWire products announced.

978 RESEARCH NOTES
 Diamond coating stops disk head crashes, radar looks through closed doors, Organic computing.

1039 NEW PRODUCTS
 Pick of the month - classified for your convenience.

1051 LETTERS
 Reed relay advice, 1.3V mystery, Amplifier stability issues, Flat-panel speakers, Beating frequencies.

Special offer

With three ranges, this sensitive frequency meter works to 2.5GHz yet costs under £100 - exclusively to EW readers. See page 1010.



This is the secret to coating disks and heads with diamond to stop hard disk crashes - see page 978.

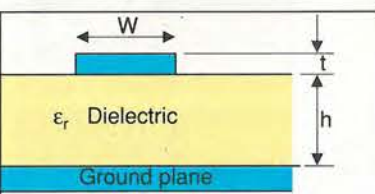

There are complex procedures for designing high performance microstripline circuits, but a few shortcuts result in a technique that is quick and easy to implement yet more than adequate for most applications, see page 1019.

1026 CIRCUIT IDEAS

- Trickier keypad lock
- Fast pulse monitor
- Analogue frequency doubler
- 5MHz triangle generator
- Precise mains volt measurement
- Lead acid battery saver
- Simple ac/dc indicator
- 50/60Hz sine oscillator
- Day indicator for digital clocks

JANUARY ISSUE ON SALE 4 DEC

OLSON

For all your Power Distribution Olson offer a varied choice

OLSON Distribution Units

OLSON DISTRIBUTION PANELS FUSED, WITH R.F. FILTER AND R.C.D. PROTECTION

OLSON FUSED SUPER SLIM 16 AMP 110V AND 240V TO BS 4343/IEC 30

OLSON "The Rack Range" mains distribution panels for 19" rack mounting

OLSON Office Furniture Cable Management Manufactured to BS 6595

OLSON Mains Distribution Panels with Non-Standard Sockets

OLSON FUSED SUPER SLIM 16 AMP 110V AND 240V TO BS 4343/IEC 30

OLSON Earth Leakage Distribution Units

OLSON Distribution Units

OLSON PANELS WITH 10AMP CEES/IEC SHUTTERED SOCKETS

OLSON The Rack Range mains distribution panels for 19" rack mounting

OLSON Mains Distribution Panels INTERNATIONAL RANGE

OLSON FUSED SUPER SLIM 16 AMP 110V AND 240V TO BS 4343/IEC 30

OLSON DATA PROTECTOR

OLSON INDUSTRIAL RANGE 16 AMP 110V AND 240V TO BS 4343/IEC 30

OLSON Distribution Units

OLSON 19" FAN TRAYS

OLSON The Rack Range mains distribution panels for 19" rack mounting

OLSON SERVICE PILLAR FOR THE OPEN-PLAN OFFICE

OLSON Distribution Units

EDITOR
Martin Eccles
0181 652 3128

CONSULTANTS
Jonathan Campbell
Philip Darrington
Frank Ogden

EDITORIAL ADMINISTRATION
Jackie Lowe
0181-652 3614

E-MAIL ORDERS
jackie.lowe@rbi.co.uk

ADVERTISEMENT MANAGER
Richard Napier
0181-652 3620

DISPLAY SALES EXECUTIVE
Joannah Cox
0181-652 3620

ADVERTISING PRODUCTION
0181-652 3620

PUBLISHER
Mick Elliott

EDITORIAL FAX
0181-652 8111

CLASSIFIED FAX
0181-652 8938

NEWSTRADE ENQUIRIES
0171 261 7704

ISSN 0959-8332

SUBSCRIPTION HOTLINE
01622 778000

SUBSCRIPTION QUERIES
rbp.subscriptions@rbi.co.uk
Tel 01444 445566
FAX 01444 445447

For a full listing of
RBI magazines:
<http://www.reedbusiness.com>

 REED
BUSINESS
INFORMATION

At last - ISDN for all

A mass-market for ISDN was never in doubt; the only thing that blurred the vision was the cost of providing it. While large organisations found it easy to cost-justify the start-up charges, the cost of entry barred very effectively the wider army of hobbyists, home-based workers and small businesses from exploiting the undoubted benefits of ISDN.

Workarounds were promised to provide alternative routes onto the information superhighway 56kbit/s modems, XDSL techniques and cable modems but none of these have offered the total flexibility of real ISDN and users still waited for the cost of ISDN to fall.

And at last this fall is imminent, now that the key to providing affordable ISDN digital telephone service has been offered to UK network operators. British telecomms manufacturer GPT, which supplies the System X exchanges used by BT and many other providers, has come up with an easy-to-install package to enhance these switches. For the first time it offers a means of providing low-cost ISDN service for the mass market of small business and residential customers.

What is particularly elegant is that it achieves not one but two breakthroughs. First, the cost barrier which held back smaller users from exploiting the acknowledged benefits of digital data communication has been eliminated. In particular, home-based workers now have a cost-effective means of exchanging documents and sharing data with office-based colleagues, as well as gaining faster access to the Internet and a host of interactive information and entertainment services to come.

Small businesses requiring high-speed data transfer no longer need to install special private wires for the purpose.

The second advantage is the fact users can enjoy the benefits of ISDN without forfeiting their existing phones and numbers. Unlike previous implementations of ISDN, customers do not forfeit useful services such as call waiting, three-way calling, ring back when free, 1471 call return,

Centrex and so on. Analogue caller display devices, which cannot operate on normal digital ISDN lines, still work under this new implementation.

It adds up to a double bonus. For network operators it is a cost-effective delivery mechanism for providing twin-channel Basic Rate ISDN (ISDN2) service without the need for a second pair of wires. The customer benefits are equally significant; users gain the enhanced capability and 128kbit/s bandwidth of ISDN while retaining the convenience and established popular features of their existing analogue connection. Because the system can provide two simultaneous connections, users are spared the cost of having a second line installed.

The technical implications are relatively modest, involving an upgrade to System X exchanges and the provision of a compact plug-in unit at the customers end for connecting a customers existing telephone equipment with direct Plug-and-Play hook-up of a PC compatible. Installing this network terminator, which replaces the existing master phone socket, does not take long and setting up takes only a minute or two; the switchover from old-style analogue to ISDN service is effectively instantaneous and requires no access to customer premises.

The all-British technology is now being proposed to the European Telecommunications Standards Institute as a pan-European standard for narrowband multi-service delivery.

For network operators the new technique provides the opportunity to offer an extremely attractive ISDN package to a large and growing market. In the same way as high-speed modems soon became affordable and commonplace, it is reasonable to expect ISDN will make digital data communication the norm for small users as well as large.

For people working from home (the so-called teleworkers), low-cost ISDN will provide cost-effective means for exchanging documents and sharing data with office-based colleagues, as well as offering faster access to the Internet and a host of interactive



The entry cost of ISDN has barred very effectively the wider army of hobbyists, home-based workers and small businesses from exploiting its undoubted benefits.

information and entertainment services to come. Small businesses will be able to link up with one another electronically to create virtual enterprises, working together to provide a single concerted service to their clients. Faster connection and data transfer will give surfing the Internet a major new impetus, opening up new prospects of online shopping and multimedia information delivery from low-cost terminals alongside the domestic television set.

Supporting this, the market for low-cost user products and solutions for ISDN is maturing rapidly, with a broad range of mini-PBXs, line cards and multi-function devices selling at truly affordable prices. One vendor offers a PC card combining ISDN file transfer at up to an effective 412kbit/s, V.34 modem emulation, Group 3 fax operation and a digital voice answering machine. It comes bundled with video conferencing software and an electronic secretary capable of storing and forwarding voice, data and fax messages. This sells for an extremely affordable 99 and with this kind of functionality on offer, users cannot fail to reconsider their attitudes to ISDN.

Andrew Emmerson

Electronics World is published monthly. By post, current issue £2.35, back issues (if available) £2.50. Orders, payments and general correspondence to **L333, Electronics World, Quadrant House, The Quadrant, Sutton, Surrey SM2 5AS.** Tel: 092984 REED BP G. Cheques should be made payable to Reed Business Information Ltd. **Newstrade:** Distributed by Marketforce (UK) Ltd, 247 Tottenham Court Road London W1P 0AU 0171 261-5108.

Subscriptions: Quadrant Subscription Services, Oakfield House Perrymount Road, Haywards Heath, Sussex RH16 3DH. Telephone 01444 445566. Please notify change of address. Subscription rates 1 year £32 UK 2 years £43.00 3 years £75.00. Surface mail 1 year £37.00 2 years £60.00 3 years £86.00 Air mail Europe/Eu 1 year £46.00 2 years £73.00 ROW 1 year £56.00 2 years £89.00

Overseas advertising agents: France and Belgium: Pierre Mussard, 18-20 Place de la Madeleine, Paris 75008. United States of America: Roy Barnes, Reed Business Publishing Ltd, 475 Park Avenue South, 2nd Fl New York, NY 10016 Tel: (212) 679 8888 Fax: (212) 679 9455

USA mailing agents: Mercury Airfreight International Ltd Inc, 10(b) Englehard Ave, Avenel NJ 07001. Periodicals Postage Paid at Rahway NJ Postmaster. Send address changes to above.

Printed by BPCC Magazines (Carlisle) Ltd, Newtown Trading Estate Carlisle, Cumbria, CA2 7NR

Typeset by Marlin Imaging 2-4 Powerscort Road, Sidcup, Kent DA1 4SDT

© Reed Business Information Ltd 1997 ISSN 0959 8332

OLSON ELECTRONICS LIMITED

FOUNTAYNE HOUSE, FOUNTAYNE RD., LONDON N15 4Q
TEL: 0181-885 2884 FAX: 0181-885 249

CIRCLE NO. 106 ON REPLY CARD

PROTEUS

The IVth Generation

Schematic Capture

NEW Version IV

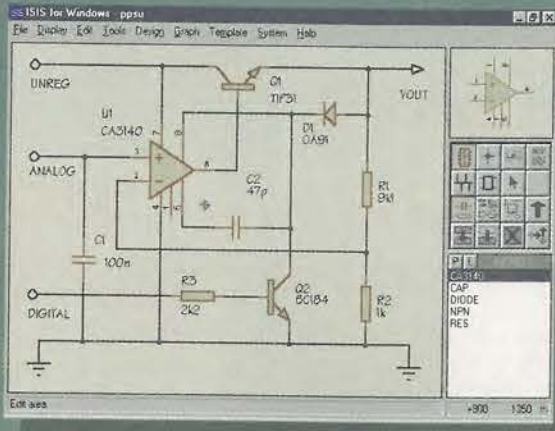

- Produces attractive schematics like you see in the magazines.
- Netlist, Parts List & ERC reports.
- Hierarchical Design.
- Full support for buses including bus pins.
- Extensive component/model libraries.
- Advanced Property Management.
- Seamless integration with simulation and PCB design.

New Features

- Component Auto-Placer
- Pinswap/Gateswap Optimizer
- Background Regeneration of Power Planes
- Enhanced Autorouting with Tidy Pass
- Full Control of Schematic Appearance
- Extensive New Component Libraries

Available in 5 levels - prices from £295 to £1875 + VAT. Call now for further information & upgrade prices.

PCB Design

NEW Version IV

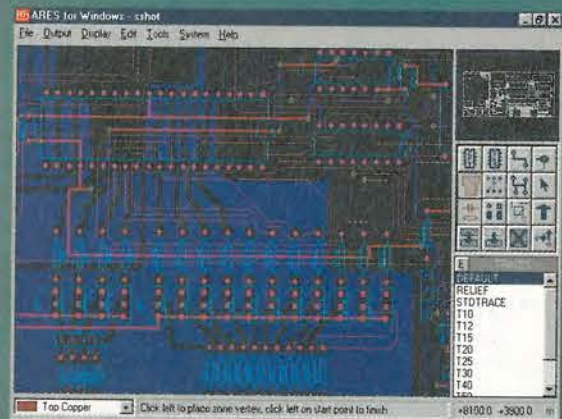

- Automatic Component Placement.
- Rip-Up & Retry Autorouter with tidy pass.
- Pinswap/Gateswap Optimizer & Backannotation.
- 32 bit high resolution database.
- Full DRC and Connectivity Checking.
- Shape based gridless power planes.
- Gerber and DXF Import capability.

Simulation

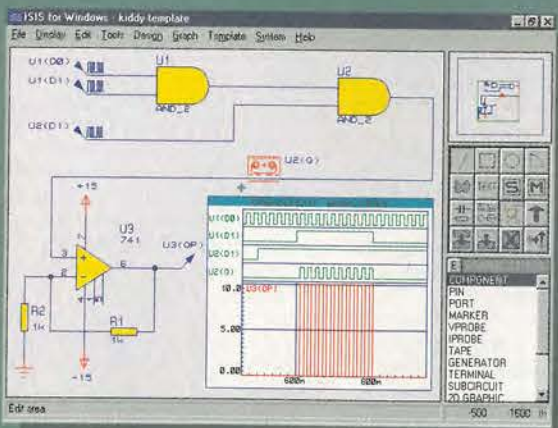

- Non-Linear & Linear Analogue Simulation.
- Event driven Digital Simulation with modelling language.
- Partitioned simulation of large designs with multiple analogue & digital sections.
- Graphs displayed directly on the schematic.

"PROTEUS is particularly good

with its rip-up-and-retry autorouter"
EWW January 1997

Write, phone or fax for your free demo disk, or ask about our full evaluation kit.
Tel: 01756 753440. Fax: 01756 752857. EMAIL: info@labcenter.co.uk
53-55 Main St, Grassington, BD23 5AA. WWW: http://www.labcenter.co.uk

Fully interactive demo versions available for download from our WWW site.
Call for educational, multi-user and dealer pricing - new dealers always wanted.
Prices exclude VAT and delivery. All manufacturer's trademarks acknowledged.

UP DATE

Bright prospects for UK employment

Employers are forecasting more jobs within the UK's electronics industry, according to a recent survey conducted by Manpower.

Meanwhile, the September pay bulletin from the engineering employers' federation (EEF) has found that pay settlements within UK industry as a whole remain

subdued and below the headline rate of inflation.

The average pay settlement for the quarter up to August was 3.17 per cent compared to 3.5 for inflation.

Manpower's latest Survey of Employment Prospects, conducted amongst 2,339 employers around the country, found 33 per cent of

electronics employers expect to recruit during the fourth quarter of 1997, against seven per cent who expect to lay off staff, registering a balance of 26 per cent.

This quarter balance exceeds the national average of 23 per cent and the manufacturing sector average of 22 per cent.

Digital tv to miss World Cup

Digital Terrestrial Television (DTT) in the UK is set to be delayed by at least three months, following the deferment in the ITC's awarding of licences. Originally DTT was to be launched in July 1998, in time for the World Cup. Now October 1998 is the expected launch date.

"There has been a gentle slippage, but as is already known, the permission from ITC came out a bit

later," said Jim Slater, project coordinator for DTT at the Digital TV Group.

Currently, the set-top box makers are waiting for the reference design from British Digital Broadcasting (BDB) for the manufacture of the first DTT receivers.

"We are currently drawing up the specification for manufacturers to build the boxes to," said a BDB spokesman.

New video camera has \$8 price tag

Edinburgh-based c-mos camera specialist Vision has added a low cost sensor to its range. The 160 by 120 pixel digital cameras are aimed at the security, videophone, toys and games markets. Eight-bit resolution monochrome and colour cameras are available. The monochrome VV5300 is priced below \$8 in volume quantities. Vision also offers a \$450 development system which includes PC software, capture card and lens.

Fairchild to decide on Temic by Christmas

Fairchild Semiconductor will make its decision whether or not to buy Temic by December. The company is also considering buying GEC-Plessey Semiconductors (GPS).

"We're still at the discovery stage - asking: 'Does Temic make sense?'" said Joe Martin, chief financial officer at Fairchild. "We'll make the decision on Temic in four to eight weeks."

"We've looked at 50 companies around the world since we spun-off from National on March 11th," added Martin. Citicorp Venture Capital, part of Citibank, financed the \$550m Fairchild management buy out and gave it a brief to look for acquisitions.

"A lot of companies have a semiconductor subsidiary for strategic products. Some want to divest themselves of these companies and Fairchild provides them with an opportunity as a credible vehicle for consolidating these sort of operations. We are actively soliciting these companies as part of our acquisition strategy," said Kirk Pond, president

and CEO of Fairchild.

Asked if Fairchild was interested in buying GPS, Martin replied: "We could be. It's only recently become available. We haven't had time to look at it yet, but it could be a possibility."

Fairchild is interested in the

semiconductor side of Temic, not the automotive components side. The main attraction of the semiconductor side for Fairchild is the former Siliconix product line of power semiconductors, including small signal transistors and its PowerMOS line, explained Martin.



Flat and wide... NEC has put into production a 50-inch plasma display intended for the high definition television market. The Hi-Vision PlasmaX panel is capable of displaying one million pixels and will go on sale in Japan next February, in time says the company, to be used in high definition tv systems to be used during the Nagano Winter Olympic Games. But UK skiing enthusiasts - an exclusive bunch at the best of times - should be warned the selling price of the 50in flat format plasma televisions will be around £2.7m (£13 000).

labcenter
Electronics

PCI bus is to get a refit

Power management and hot-plug capabilities are to be added to the PCI-bus, it was announced recently. Version 2.2 of the PCI specification is to be released early next year, said Donald Coffin of the PCI special interest group.

"Power management is the hardware side of Microsoft's ACPI or advanced configuration and power interface," explained Coffin.

ACPI allows parts of a PC to be powered down when not in use. Notebook PCs are already early

adopters of the technology. By adding ACPI to the computer's local bus, peripherals will be more energy efficient.

Hot plug is aimed for use in servers, so that disk and Ethernet cards can be swapped without shutting down the system.

The last major update to the PCI specification, version 2.1, was released two years ago. This extended the bus from 32-bit at 33MHz to 64-bit at 66MHz. Bandwidth quadrupled to 528Mbyte/s.

"We are now seeing 64-bit, 66MHz systems, especially in servers," said Coffin.

The move to the higher rate will continue in servers and workstations over the next year to 18 months, claims Coffin.

Desktop PCs are likely to continue with the 32-bit, 33MHz version. This is because Intel's accelerated graphics port (AGP), which links the graphics system directly to the microprocessor, has greatly reduced the burden on the PCI-bus.

Awareness funding for year 2000 bug redirected

The Government is to stop funding Taskforce 2000, the body assigned to raise awareness about the Millennium bug. Instead, £1m will be given to Action 2000, a new organisation tasked with taking a more active approach to the problem.

Robin Guenier, head of Taskforce 2000, criticised the decision, saying it would waste valuable time. "We're going to lose weeks while people are appointed to [Action 2000]," he said.

"Wouldn't it have been more sensible to continue with Taskforce 2000?"

A DTI spokesman countered: "Taskforce 2000's aim was to raise awareness and it did it very well. However, companies are not doing enough and a new impetus is required to turn awareness into action. We are showing our commitment, now it's up to industry to make its contribution."

Guenier insisted there is still a need to continue with his awareness programme, especially with regard to how Year 2000 affects embedded systems, to get the whole of industry and commerce tackling the problem rather than just helping the estimated 15 per cent that have already begun.

However, the DTI spokesman stressed the awareness campaign would continue as part of Action 2000's ambit.

UK electronics industry warned

The UK electronics industry faces a great threat from Eastern European-based manufacturing, according to a paper from Loughborough University.

Professor David Williams, presenting the paper to the Cambridge Centre for International Manufacturing, warned that Eastern Europe threatens "unrooted" inward

investments in the UK, and that even embedded foreign investment in Scotland is vulnerable. "Screwdriver inward investments will probably go to places like Poland and the Czech Republic," he said, pointing out that IBM had already transferred disk drive manufacturing capacity from Havant to the Republic.

Williams believes UK electronics companies need a greater awareness of their global role if they are to survive well into the next century. Success will mainly come for firms that couple investment in high value-added activities with sales into mature economies like the US. "Should we sell expensive products to rich Americans or cheap products to the Chinese?" he said.

But the UK must not pass up opportunities in the Far East for long term investment in areas of industrial growth. "We can't afford to miss another trick like we did with Singapore, where a low value region becomes a high value one," said Williams.

NEC details handheld Risc chip

NEC has released details of its latest microprocessor for the handheld computer (HPC) market.

The VR4111 is a 64-bit Risc microprocessor based on the R4000 core from MIPS Technologies. It is an updated version of the VR4101 and 4102. The new devices are pin-compatible with the previous processors to allow easier design upgrades.

Performance reaches a claimed 130Mips at 100MHz by moving the device to a 0.25µm manufacturing process. Power consumption has been reduced from 250mW to 180mW by running the device at 2.5V.

To reduce memory requirements, the devices can execute a 16-bit instruction set, similar to the ARM Thumb.

NEC has integrated HPC-specific peripherals for LCDs, keyboards, infra-red and serial I/O, audio and touch screen interface.

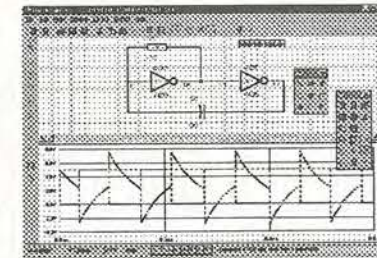
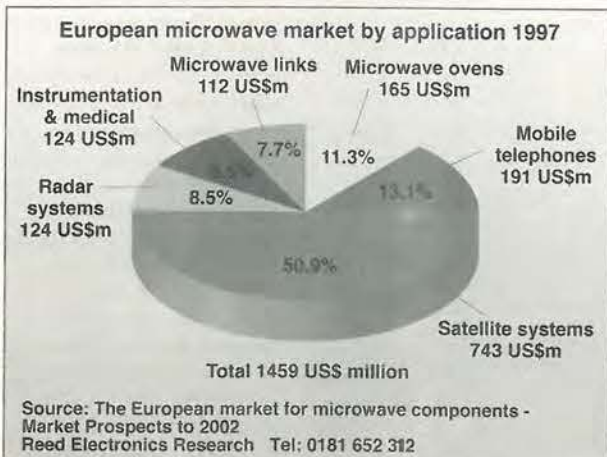

Schematic Capture with a FREE mixed mode simulator.

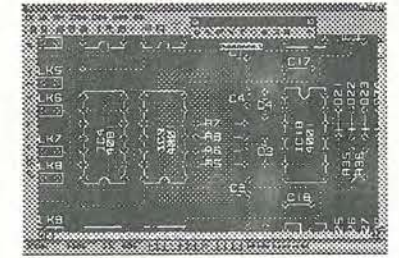

Integrated PCB Design with autorouter & CAD/CAM support.

Looks like Quickroute 4.0 has Got It All!

The new Quickroute 4.0 is here and with it a revolution in our price/performance structure. We've kept the features the same at all levels of Quickroute and just varied the number of pins you can use in a design. So now you can get started FAST with Quickroute 4.0 for just £79 (300 pins), £149 (800 pins) or £249 (full access). Prices exclude P+P and VAT.

All versions of Quickroute 4.0 now include:
 *New user interface with dockable tool bars *Multi-sheet schematic capture *Power rail & data bus support *1-8 layer autorouter *For a limited period a FREE integrated 32 bit mixed mode simulator *Copper Fill *Engineering Change *Gerber import and export *Export NC-Drill, WMF, DXF and SPICE files *Netlist import and export *Over 1000 library parts

Send me a FREE DEMO. My name, address & phone number are:



Send To: Quickroute Systems Ltd, FREEPOST 13136, Stockport, SK4 1BS
 Outside the U.K please fax this coupon. (c) 1997. All rights reserved. Ref 401.

CIRCLE NO. 108 ON REPLY CARD

Circuit simulation can be seriously good fun

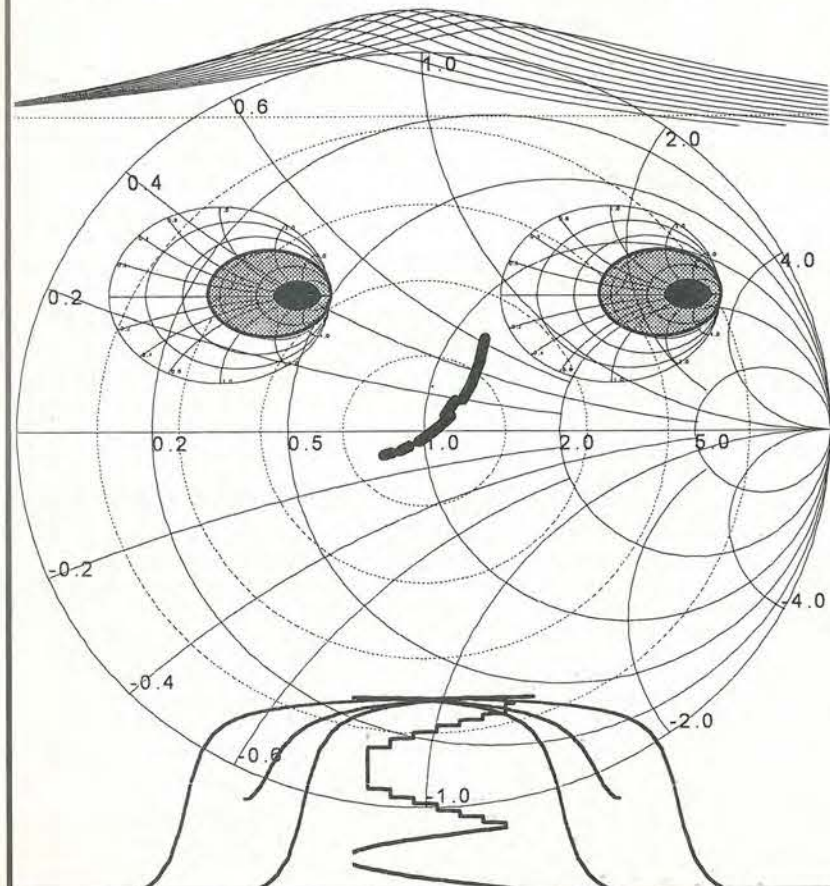

Those Engineers Ltd

When you have the engineering edge, enjoy your work and catch subtle circuit behaviour before it's too late, you can afford to be light hearted. Add to this technical support from practising engineers who take a genuine interest in your work and you are really laughing.

With a free evaluation kit, you can test SpiceAge on your own circuits. The kit comes with an introductory booklet to show you how.

To hear more about this and other nice touches in SpiceAge, please contact the friendly people at

Those Engineers Ltd,
 31 Birkbeck Road,
 LONDON NW7 4BP.

Tel 0181 906 0155
 Fax 0181 906 0969
 Email those_engineers@compuserve.com
 Web http://www.spiceage.com

CIRCLE NO. 109 ON REPLY CARD

Future bleak for NCs

Network computers (NCs) could be dead in the water as network managers decide to stick with existing network equipment.

This message emerged from a Fodor Wyllie survey commissioned from Pin Point Software, the network management tools supplier.

According to the survey, 56 per cent of companies questioned did not believe the NC would make a significant impact on their organisations even though network management would be made easier.

"The momentum for network computers has been lost. We were amazed at the ambivalence towards the network computer. Clearly there is a belief that the NC can help but there's a lot of pessimism about its

implementation," said Iain Franklin from Pin Point Software. "Although the NC saves a lot of time managing the network, companies prefer to stick to what they have rather than switch their whole networks to NCs."

According to Pin Point Software this is a surprising revelation as the market for network management devices is growing at a rate of 30 per cent per year and it has already reached the \$1bn mark.

Another analyst, Bloor Research disagrees. "I don't believe the momentum for NCs is lost," said Rob Hailstone, chief analyst at Bloor Research. "I suspect until we see the first successful implementation of NCs people will think it's not going to happen."

Guidelines aimed at cutting keyfob interference

The chance of getting locked out of your car by EMC problems should be reduced if guidelines by RAKE, the Radio Activated Key Committee, are adopted.

Problems arise because EU legislation added automotive keyfobs to the list of legitimate users of 433.93MHz in the UK, which already included the MoD and radio amateurs. "We are in no position to ask the other user to get off the frequency - the radio amateurs have been using it for over 40 years," said Peter Brill, RAKE spokesman at the RAC.

This said, the guidelines contain the paragraph: "As a first step, in the UK, the next two years will see the removal of some users of the 433MHz band to other parts of the spectrum".

The guidelines are split into two parts: a guide to motorists and a guide to manufacturers for future products.

"One of the simple things we are encouraging manufacturers to do is ensure there is an alternative method of entry," said Brill.

Other guidelines suggest marking 'hot spots' on and in the vehicle where it is most sensitive to the keyfob being held, visible instructions to remind drivers what to do if the fob fails to operate the car and a reduction in receiver bandwidth.

Motorist Web update:
<http://www.rac.co.uk/html/fut/pr971008.htm>

Initial products for FireWire announced

The first FireWire products are to start appearing on the market in the next six months, two years after the IEEE1394-1995 standard was agreed.

"We had the standard two years ago. It's time to start generating products this and next year," said Hiro Tsutsui, marketing manager at Sony Image Sensing Products in Japan.

Intel will deliver a prototype motherboards with the FireWire-1995 digital interface early next year. The software by Microsoft will also cater for this type of linking then and Apple will introduce Power Macs with this interface.

Last week, Sony announced its DFW-V300 digital colour camera, one of the first FireWire peripherals, with this high-speed

serial bus standard on board. In 1998, Sony hopes to launch another six products from its image sensing portfolio.

"The real benefit is that IEEE-1394 standard allows digital data to be imported directly into a PC or device, meaning the DFW-V300 camera provides a very quick and very scalable solution for transferring video data for processing by computer," said Steve Hearn, business manager at Sony Image Sensing Products.

The next FireWire specification, IEEE1394-1998 or IEEE1394-2000, is being discussed between the industry players and the standardisation bodies including the 1394.b Working Group that is working towards the 3.2Gbit/s specification.

In brief

New specs for DVD

The latest specification for the write-once DVD-Recordable (DVD-R) format has been published by the DVD Forum. The version 1.0 specification offers a 3.95Gbyte single-sided or 7.9Gbyte double-sided storage capacity that will be compatible with other DVD formats such as DVD-ROM and DVD-Video. The next generation 4.7Gbyte DVD-R is currently under discussion by the DVD-R Working Group. Meanwhile, Matsushita Electric Industrial expects first-year total worldwide sales of DVD players to be half of that first envisaged. Initial forecasts were for sales of up to two million units, however, the forecasts have been downgraded to below one million units.

Risc processor for hand-helds

NEC has released details of its latest microprocessor for the handheld computer (HPC) market.

The VR4111 is a 64-bit Risc microprocessor based on the R4000 core from MIPS Technologies. It is an updated version of the VR4101 and 4102. The new devices are pin-compatible with the previous processors to allow easier design upgrades.

Performance reaches a claimed 130Mips at 100MHz by moving the device to a 0.25µm manufacturing process. Power consumption has been reduced from 250mW to 180mW by running the device at 2.5V.

To reduce memory requirements, the devices can execute a 16-bit instruction set, similar to the ARM Thumb.

NEC has integrated HPC-specific peripherals for LCDs, keyboards, infra-red and serial I/O, audio and touch screen interface.

CO₂ will affect chip production

Global warming will affect the semiconductor industry, says a report from the Economic Strategy Institute of Washington DC.

The Institute warns that if proposals to cut CO₂ emissions proposed by the Kyoto global warming summit are adopted, then the global economy will slow down leading to an eight per cent reduction in the demand for semiconductors.

WE PUT EVERYTHING INTO OUR NEW 48-PIN UNIVERSAL PROGRAMMER

1.8V
2.7V
3.3V
5V



Approved by major manufacturers including:
AMD
Microchip
Atmel
National Semiconductor



THEN ADDED MORE

FEATURES

- Supports EPROMs, EEPROMs, Flash, Serial PROMs, BPROMs, PSDs, PALs, GALs, PEELs, MACH, MAX, EPLDs, and nearly 200 Microcontrollers including 87C48/51, 89C51/52, PIC, MC705/711, ST6, Z86, COP etc.
- Correct programming and verification at 1.8, 2.7, 3.3 and 5V
- No adapters required for DIL parts upto 48-pins. Universal adapters for 44-pin PLCC, 44-pin PSOP and 48-pin TSOP parts
- High speed: programmes and verifies National 27C512 in under 11 seconds
- Connects directly to standard parallel port - no PC cards needed
- Built in chipster for 7400, 4000, DRAM, SRAM
- Lightweight and mains or battery operation
- Complete with parallel port cable, software, re-charger and documentation

- FREE software device support upgrades via bulletin board and ftp
- Next day delivery
- Full range of adapters available from £65 for upto 84-pins for PLCC, SOIC, PSOP and TSOP

PROGRAMMER MODELS AND PRICES

LV MODELS (SUPPORT 1.8V, 2.7V, 3.3V and 5V DEVICES)		SPEEDMASTER 1000+	EPROMs, EEPROMs, Flash, NVRAMs, Serial PROMs, Serial EEPROMs, BPROMs, GALs, 8748/51	£395
EPMASTER LV	EPROMs, EEPROMs, Flash, Serial PROMs, Serial EEPROMs 8 to 40 pins all without adapters. Built in emulator modules: 128k by 8: £395 128k by 16: £465	MICROMASTER 1000+	EPROMs, EEPROMs, NVRAMs, Flash, Serial, BPROMs, PALs, GALs, PEELs, MACH, MAX, PSD, nearly 200 microcontrollers without adapters.	£525
SPEEDMASTER LV	EPROMs, EEPROMs, Flash, NVRAMs, Serial PROMs, Serial EEPROMs, BPROMs, GALs, PALs, EPLDs, MACH, MAX, 8748/51.	SPEEDMASTER GLV32	High speed EPROM/Flash 8 way Gang/Set Programmer. Supports 3.3V and 5V	£695
MICROMASTER LV	EPROMs, EEPROMs, NVRAMs, Flash, Serial, BPROMs, PALs, GALs, PEELs, MACH, MAX, PSD, nearly 200 microcontrollers without adapters.	COP GANG PROGRAMMER	8 way Gang programmer for National Semiconductor COP family of micros COP87xxC, COP87Lxx and COP85Ax	£1500
LV40 PORTABLE	All devices supported by Micromaster LV, plus completely portable with built in keypad and LCD display.	SOCKET ADAPTERS	for PLCC, TSOP, SOIC, etc.	from £65

All prices exclude VAT and delivery

Only £695

For a copy of our catalogue giving full details of programmers, emulators, erasers, adaptors and logic analysers, call, fax or e-mail us. You can also access our BBS or Home page. All our products are in stock now for next day delivery - call our credit card hotline now.



ICE Technology Ltd. Penistone Court, Sheffield Road, Penistone, Sheffield, UK S36 6HP
Tel: +44 (0)1226 767404 Fax: +44 (0)1226 370434 BBS: +44 (0)1226 761181 (14400, 8N1)

Web: www.icetech.com. Email: sales@icetech.com

CIRCLE NO. 110 ON REPLY CARD

RESEARCH NOTES

Jonathan Campbell

Diamond coating adds twinkle to disk storage

One of the major stumbling blocks in the design of ultra-high storage disk drives is that the read/write heads must be located ever nearer to the disc surface to be able to resolve the data. At these tiny distance, impacts are inevitable so the heads must be coated. But any protective coating must be super thin too, so as not to disturb magnetic performance.

Now, a way has been found to shield disks and sliders – reader heads – with ultra-thin ‘overcoats’ of diamond-like carbon that can survive repeated crash landings at 3600rev/min. Success is being welcomed as a breakthrough in progress to high density storage devices.

Towards more reliable hard disk drives – ionised plasma follows the curves of the magnetic field, but unwanted macroparticles just hit the wall.

The work has been carried out by Simone Anders of the Accelerator and Fusion Research Division at the Ernest Orlando Lawrence Berkeley National Laboratory and her colleagues from IBM and University of California, Berkeley.

IBM has already brought to market disks that store 4Mbytes/mm² of data, while densities almost twice that have been demonstrated, and researchers are aiming for 16Mbytes/mm² and more. To read a disk where magnetic domains are packed only 25nm apart, disk surface and slider will have to move so close to each other that it's almost a matter of semantics whether they will actually be touching.

Typical high-quality commercial overcoats now in use are made of sputtered-on, hydrogenated carbon 12 to 15nm thick. But higher data densities require reduced magnetic spacing between heads and disks – so disk coatings must be thinner and made of even harder material. Sputtering can't do the job, but a technique called cathodic arc deposition can.

Unlike sputtering, cathodic arcs produce a fully ionised plasma of whatever material, including carbon, is used for the cathode.

A fully ionised carbon plasma

allows electrons and carbon nuclei to reassemble themselves as diamond, in a three-dimensional lattice in which each atom is bound to four others by electron pairs – a tetrahedral bond. In contrast, atoms in graphite are bound to only three other atoms, forming a much less stable configuration. By tuning the energy of the incoming carbon ions, the tetrahedral-bond content of the deposited film can be optimised, so films have been made that, while technically amorphous, are 85% diamond.

“Still, the method hasn't been practical for coating disks,” says Anders, “because micron-sized chunks of the cathode boil off and contaminate the films.”

For cathodic arc deposition to be useful in coating disks and sliders, a way must be found to completely filter out the macroparticles. What Anders and her team has achieved is to devise a filter so good that all the goals of thin, flat, hard, macroparticle-free carbon are fulfilled.

The secret is a magnetic coil that looks much like a Slinky toy, placed between the plasma source and the substrate to be coated. The fully ionised plasma is easily bent through this S-shaped magnetic field – effectively two fields at right angles – but the massive macroparticles of carbon can't turn easily; they fly right through the sides of the coil or pile up on its walls. A coil that has been used for some time is thickly coated with a dust of macroparticles near the plasma source, yet dust-free at the substrate end.

Tests show that disks coated with cathodic arc carbon have a coefficient of friction half that of those coated with hydrogenated carbon and cause 20 times less wear on the slider. In additional studies, when a silicon wafer coated with cathodic arc carbon has been examined at nanometre scale after repeated loading, it shows virtually no scratches.

Contact, Simone Anders, Accelerator and Fusion Research Division, Ernest Orlando Lawrence Berkeley National Laboratory, Berkeley, California, USA

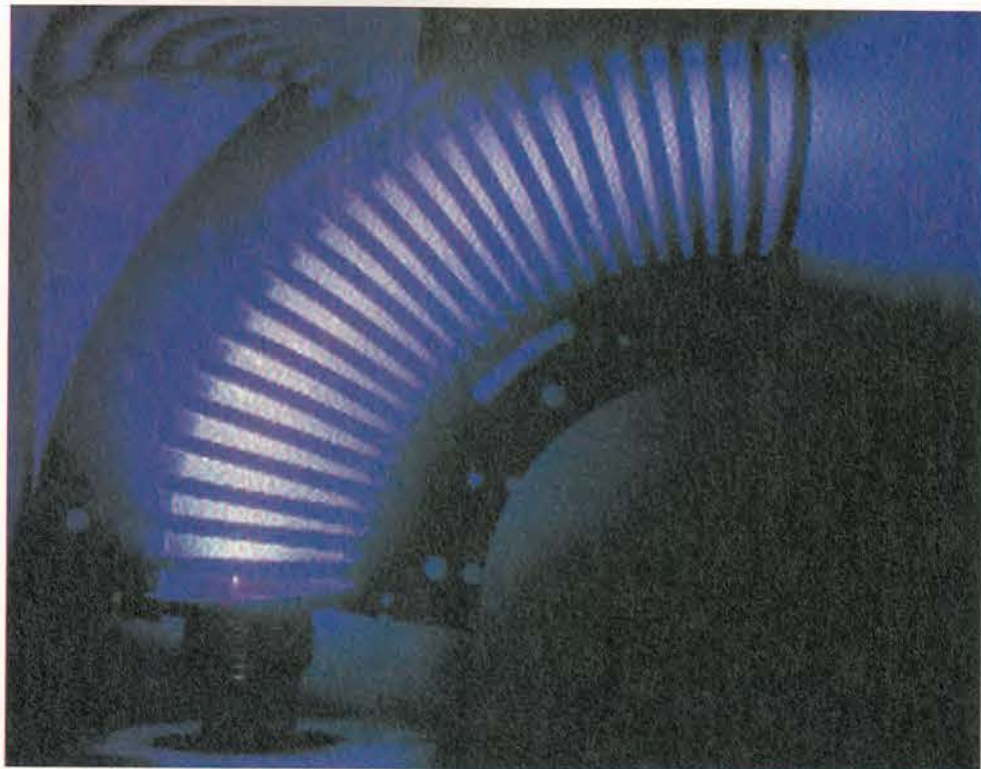

Radar finds people behind locked doors

Lives could be saved by a prototype radar system, developed at Georgia Tech Research Institute, that can sense someone moving or breathing up to 3m behind a locked door. For police and hostage negotiators, the device, little bigger than a torch could provide vital information about where people are located inside a room. The sensor could also be used to find survivors in the rubble of accidents or earthquakes.

A narrow radar beam of about 15 to 20° and a specialised signal processor is used to detect the body movement generated by breathing.

Research that evolved into the radar torch began in the mid-1980s, with the patenting of a frequency modulated radar for remotely checking vital signs of battlefield wounded before sending in medical teams. This early technology was also tested for its ability to monitor vital signs of soldiers clothed in chemical or biological warfare suits, without requiring them to risk contamination by removing the protective gear. Now the technology has been refined for more general use.

Radar has some advantages over other technologies. The signal from the radar will penetrate clothes and detect respiration through a heavy jacket, and requires a body movement of only a few millimetres to detect human presence.

“Based on respiration signature alone, the radar flashlight allows us to detect a stationary individual behind a solid wooden door, or standing 1.2m



behind a 200mm block wall,” explains Gene Greneker, a principal research scientist at the GTRI.

Even so, the amount of electromagnetic radiation exposure from the device is still small – said to ten times less than the voluntary exposure leakage level for microwave ovens in the United States. Exposure is estimated to be about the same as a person receives when walking under an automatic door opener triggered by a microwave sensor.

For now, the signal processor is

external to the radar sensor, and the respiration signature is displayed on a monitor driven by a computer-based radar signal processor. But Greneker plans to make everything small enough to fit inside the torch body by incorporating high-speed signal processing technology.

Contact: Gene Greneker, Georgia Institute of Technology, 223 Centennial Research Building, Atlanta, Georgia 30332-0828. Tel: 00 1 770-528-7744 email: gene.greneker@gtri.gatech.edu

The radar torch can detect the presence of a human through a wall or door (Stanley Leary, Georgia Tech)

Chill settles on car electronics

Electronics are now almost as an important component of cars as the engines and bodies themselves. Over at the Daimler-Benz Research Centre in Ulm, scientists are putting the next generation of microwave circuitry through its paces, using a specially-constructed low-temperature measuring station allows researchers to investigate the characteristics of new microwave circuits at temperatures far below freezing point. In this way, any adverse effects on the performance of superconductor elements can be predicted.

At the measuring station, tests can be carried out at temperatures as low



Daimler-Benz has constructed a rig specially designed for low temperature testing of microwave components.

as -250°C , allowing the scientists to examine new components for high-power radar sensor units or for compact narrow-band receivers in communications technology, while detailing their behaviour at extreme sub-zero temperatures. On the basis of these results, the characteristics and capabilities of

superconductor elements can be precisely predicted.

The use of superconductor materials in place of metals and the resulting new approaches to modelling in hybrid combination are seen as milestones along the road to new, highly sensitive receiver systems for the microwave

band. The objective is to benefit from the advantages of various available components and unite them in a single overall system. * Automotive researchers currently regard this as the most cost-effective solution for the production of such components in small and medium volumes.

Organic computer comes closer...

Researchers at Yale University in the US have succeeded for the first time in measuring an electric current flowing through a single organic molecule sandwiched between metal electrodes. The feat could pave the way for a new generation of transistors so small that a beaker full would contain more transistors than exist in the world today, according to Yale electrical engineer Mark Reed, team leader.

The accomplishment is a fundamental step toward creating computers and sensors that are smaller, faster and cheaper than today's silicon-based computers. The next step is to design computer chips whose wires are made of self-assembling strings of organic molecules that grow in a beaker, since the wires would be far too small to produce any other way. The organic wires would adhere to metal electrodes, a revolutionary strategy for fabricating electronic devices for which Professor Reed and Yale hold a joint patent.

But Reed warns that it could take a decade to learn how to make useful devices out of quantum components made from organic compounds.

To capture the historic measurement of current across a single organic molecule, the researchers made a mechanically controllable break junction by gluing a notched gold wire to a flexible substrate, then fracturing the wire to make an adjustable gap. Next, they sandwiched a single molecule of benzene (a hexagonal ring made up of six carbon and six hydrogen atoms) flanked by

two sticky sulphur atoms between the two gold electrodes. The process required self-assembly of benzene molecules onto the electrodes.

For the future, perhaps the greatest obstacle to be overcome in fabricating useful quantum devices is to find better, faster ways to make large quantities. Electron beam lithography is used at the moment and this is just not practical for volume production.

...But can silicon wait?

Progress to ever smaller, faster and cheaper computers may soon come to a grinding halt because microscopic silicon chips are getting so small that eventually they will contain too few atoms to work, warn two University of Florida researchers.

By the year 2010 the limit will be reached, and microprocessors will be as small and as fast as they can get, says Kevin Jones, professor of materials science and engineering and co-director of UF's SoftWare and Analysis of Advanced Material Processing (the Swamp Center).

Jones and Swamp co-director Mark Law are concerned that the heart of the Pentium processor transistor, a layer that once was thousands of atoms thick, is getting so small that it soon will be only 50 atoms thick. They say the Pentium processor may eventually shrink itself out of function when it gets to be fewer than 10 atoms thick, in just over a decade. That means unless there is a revolutionary change in computer technology, the trend toward smaller, faster computers

The answer could be to find materials that will assemble themselves into quantum components.

Reed says his goal is to find organic chemicals that will combine to form a substrate of conducting molecules.

Contact: Professor Mark Reed, Yale University, New Haven, Connecticut, USA, Tel: 00 1 203 432 4306 email: reed@yale.edu

will have reached its limit.

Effectiveness of shrinking processors is also threatened by the impurities in microscopic silicon chips. Law and Jones are currently using 3d computer simulation to investigate the nature of the impurities in silicon which can cause current to flow where it is not supposed to.

Impurities can cause catastrophic failure when the impurities run into the crystal and cause electronic switches to short circuit.

The researchers are currently making predictive models for the industry, primarily using computer simulation because testing with real materials is so expensive.

"We need to know how impurities diffuse, at what rate and at what temperature," says Law.

"We can then code that data and build predictive models that allow the industry to build better chips." ■

Contact: Kevin Jones, University of Florida, Gainesville, USA. Tel: 00 1 352 392 9872.

The Balance Box

Microphone or line level amplifier for balanced or unbalanced signal lines

Professional portable units operating from an internal PP3 battery or external mains adaptor

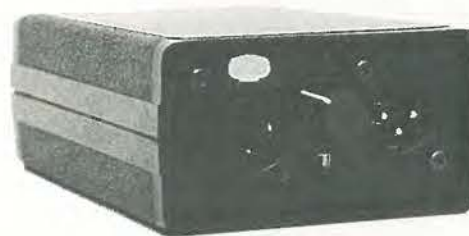

- ★ Precision true floating transformerless balanced input and output at microphone or line level
- ★ Simple interfacing and conversion between balanced and unbalanced signal lines
- ★ Low noise and distortion
- ★ High common mode rejection
- ★ Switchable gain selection
- ★ Extensive RFI protection

The Phantom Power Box – The Headphone Amplifier Box - The OneStop DIN rail mounting radio frequency interference filter and voltage transient protector for voltage and current loop process signal lines

Conford Electronics Conford Liphook Hants GU30 7QW
Information line: 01428 751469 Fax: 751223
E-mail contact@confordelec.co.uk
Web <http://www.confordelec.co.uk/catalogue/>

CIRCLE NO. 111 ON REPLY CARD

MARCONI 2370 Spectrum Analyser (as new)

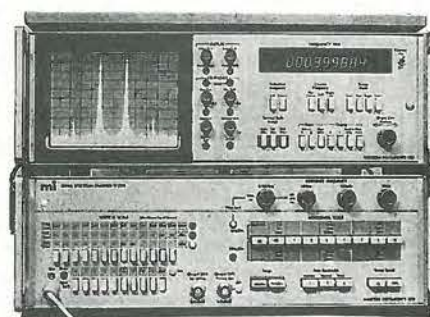

30Hz – 110MHz Frequency range
1Hz Resolution/phase lock tuning
Digital storage with dual display
Built-in tracking generator
9 digit frequency counter

£750 + carriage/vat

Includes 30 day unconditional warranty
M&B Radio, 86 Bishopgate Street, Leeds LS1 4BB
Tel: (+44) 0113 2435649
Fax: (+44) 0113 2426881

CIRCLE NO. 112 ON REPLY CARD

Radio Technology Direct

Top quality, top technology, top service. That's our commitment to you. We build both standard and custom modules and ship direct. We've been doing so for 20 years. No-one is better. Every product is made in England, with pride.

Here are some of our products. To order, just ring us direct (credit cards accepted).

If you want something you don't see here, ring us. We can almost certainly help.

SX450 The Wood & Douglas Flagship



- 500mW output
- UHF operation
- Fully synthesised
- Fully ETSI approved

£250
Volume Orders

RSX450 Intelligent Radio Modem

- 500mW output
- 9600 baud on air data rate
- Fully synthesised
- Fully ETSI approved



£450
Volume Orders

ST/SR450 The Discerning Discretes



- 500mW output
- Separate TX and RX units
- UHF operation
- Fully synthesised
- Fully ETSI approved
- VHF options available
- Rich in features

TX £120
Volume Orders

RX £140
Volume Orders

TT/TR Low Cost Modules

- 100mW output
- Separate TX and RX modules
- UHF operation
- Crystal controlled
- Fully ETSI approved



TT £50
Volume Orders

TR £80
Volume Orders



Wood & Douglas Limited
Lattice House, Baughurst, Tadley, RG26 5LP United Kingdom
Tel: +44 (0)118 981 1444 Fax: +44 (0)118 981 1567
e-mail: info@woodanddouglas.co.uk
<http://www.woodanddouglas.co.uk>

CALL NOW **+44 (0)118 981 1444**

CIRCLE NO. 113 ON REPLY CARD

In petrol-engine efficiency terms, an increase of 5 to 10% is exceptional. Automotive engineer Michael Ward says that his ignition system can achieve this – and it can do so with the side benefits of cheaper emission-control systems together with simpler engine mechanics.

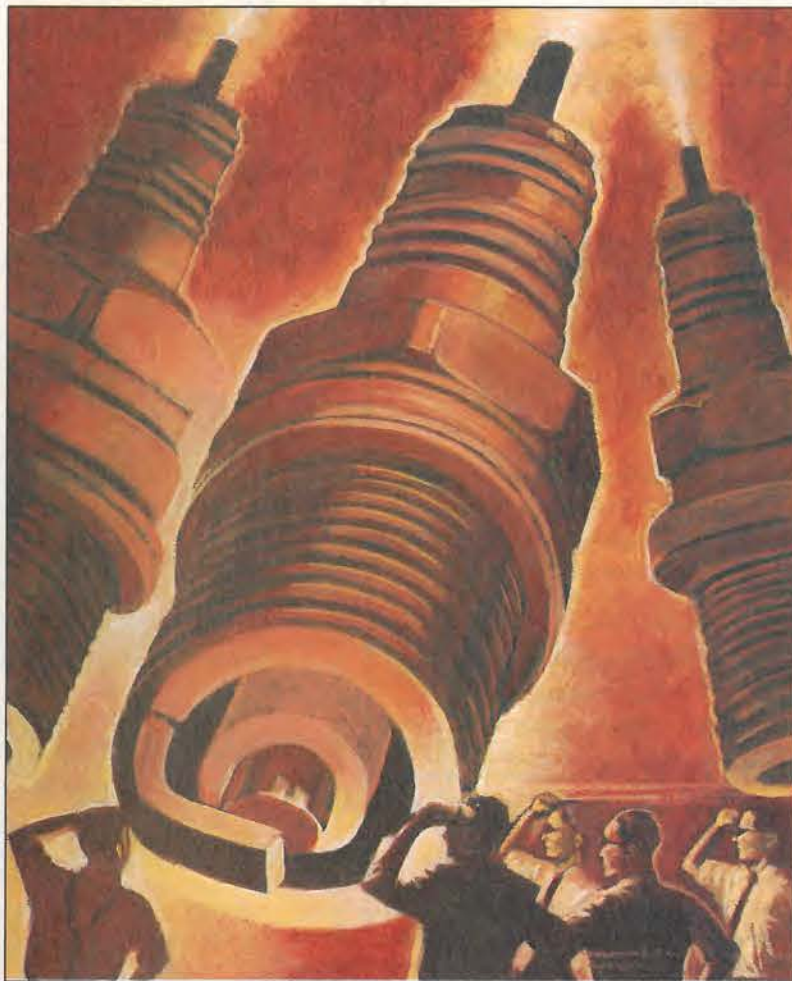

Bright sparks

The conventional inductive ignition system, based on the flyback circuit, has survived without significant challenge for almost a century. Invented and developed by Charles Kettering, circa 1910, it powers essentially all passenger cars and trucks today. It features simplicity, low cost, and reliability. However, it masks several shortcomings – including low spark energy relative to what is required for best engine efficiency. These shortcomings are taking on a particular importance with the industry's call for one-coil-per-plug ignition and with the international call for improved fuel efficiency to counter ever growing carbon emissions worldwide – which equates to global warming. Related concerns of high fuel costs in Europe and Japan, and failing Corporate Average Fuel Efficiency standards, CAFE, in the US further increase the concerns. The increased popularity of minivans, sport-utility vehicles, and light trucks in the US is leading to a reduction in vehicle gas mileage – the lowest since 1985 – and to growth in US oil imports to over 50%. In the latter seventies, Robert Bosch and General Motors showed that for best engine efficiency, an ignition system needed to deliver 150 to 250 millijoules of spark energy. Yet today's inductive ignition systems

Dr Michael Ward is President of Combustion Electromagnetics Inc., Arlington MA.

deliver only a small fraction of that – typically 30 to 50mJ as measured by an 800V zener load, which is the industry standard. Without a substantial increase in coil weight, from the state-of-the-art 200g to an unacceptable 500g, the required minimum spark energy of 150mJ cannot be achieved. Moreover, today's inductive ignition systems deliver a spark with a current of 50 milliamps. This equates to a spark power of just 20 watts. But to achieve the optimum combustion power in the initial propagating flame demands a spark of around a 100W. More importantly, such spark discharges are susceptible to break-up by the high mixture flows found in engine cylinders of modern engines. Why a bigger spark? From the 20 years of research conducted at CEI on ignition and early flame propagation, we have found that spark power more closely equal to that produced by the initial flame is better suited for ignition of dilute mixtures. This equates to lean or high exhaust-gas recirculation, or EGR, mixtures which increase engine efficiency and lower emissions. Such higher-power spark discharges require spark currents above 200mA, which is the demarcation

between a low current 'glow discharge' with its high electrode drop and low efficiency, and the 'arc discharge' with its low electrode drop and higher efficiency. The arc discharge has a much greater resistance to flow segmentation, allowing the spark to be located in a more central portion of the combustion chamber where it can interact with the flow to provide the greatest lean burn capability – as we have demonstrated to the Japanese and General Motors.

Existing ignition shortfalls

Meeting the combined goals of high energy, light coil weight, high spark current, and high spark flow resistance needs a different approach to inductive ignition. To this end, we have developed a new type of hybrid inductive ignition, which we call HBI. It is based on improvements in insulated-gate bipolar transistor, or IGBT, technology and innovations in circuit and component design. The basic inductive ignition system is made up of the car battery of voltage V_b , the ignition coil T , the power switch S , the clamp D , and the load which is a spark gap G on the coil secondary winding, Fig. 1. In operation, the system is fired to sequentially store magnetic energy in the core of the coil through current flow in the primary winding of inductance L_p to a maximum peak 'break' current I_p . This current produces a positive sense voltage in the sense resistor r which is measured by a sense and control circuit.

When switch S opens, the voltages on the primary and secondary windings rise. Initially, the primary voltage rises due to the coil leakage inductance L_{pe} energy charging the primary circuit capacitance and getting clipped and dissipated by a clamp D . Primary voltage then rises in phase with the secondary voltage V_s to charge the secondary capacitance C_s . It continues up to the spark gap breakdown voltage V_{br} , to deliver the remaining energy stored in the core to the spark gap.

Breakdown voltage V_{br} depends mainly on spark-gap size and engine load – as measured by the cylinder volumetric efficiency. It is typically 5 to 30 kilovolts. Peak output voltage, V_{spk} , is controlled by the clamp D , which for a coil turns ratio N of 90, and assumed clamp voltage V_{cl} of 380V, limits the peak voltage to approximately 36kV as a result of transformer action. This value is greater than $N \times V_{cl}$ due to imperfect winding coupling. The energy that can be stored in the core, E_p , must satisfy limitations on the peak core magnetic flux density B_p given below, where N_p is the primary winding turns and A_p is the core

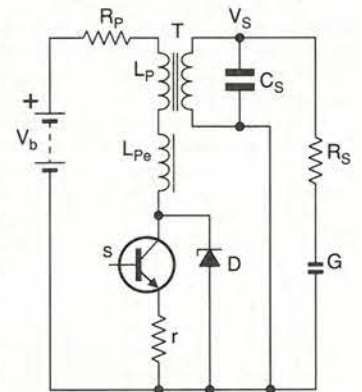

Fig. 1. In the basic ignition system, arcing at the load, i.e. the spark plug, is caused when the switch opens to transfer energy stored in the coil.

Advances in spark plug design

Significant work has been taking place recently in improving the design of spark plug tips to minimise their quenching effects on the ignition spark and on the early flame propagation, as well as to increase spark plug life.

Such plug designs are of particular interest in this application since the HBI system produces a spark with a higher spark current which is much less susceptible to being quenched or segmented, i.e. broken up by high in-cylinder flow velocities.

HBI would preferably use such spark plugs with a larger spark gap enabled by the higher output voltage of the ignition. The plug tip would be placed well within the combustion chamber within the flow stream to provide even greater capability for dilute combustion, i.e. lean or high EGR burn, to further improve engine efficiency.

CEI has developed its own patented version of a spark plug, called halo-disc, which was successfully tested at one of the Big Three and gave an actual fuel economy improvement in and of itself. The spark plug features a thin, suspended, ground ring electrode to minimise electrode obstruction and quenching. The electrode is best made of erosion resistant material such as tungsten-nickel-iron, and has a recessed insulator to minimise fouling of the insulator end.

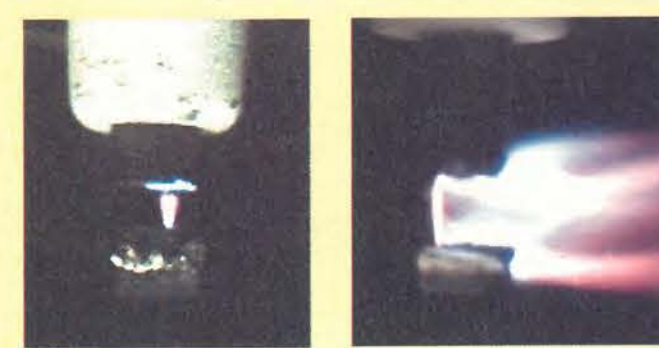
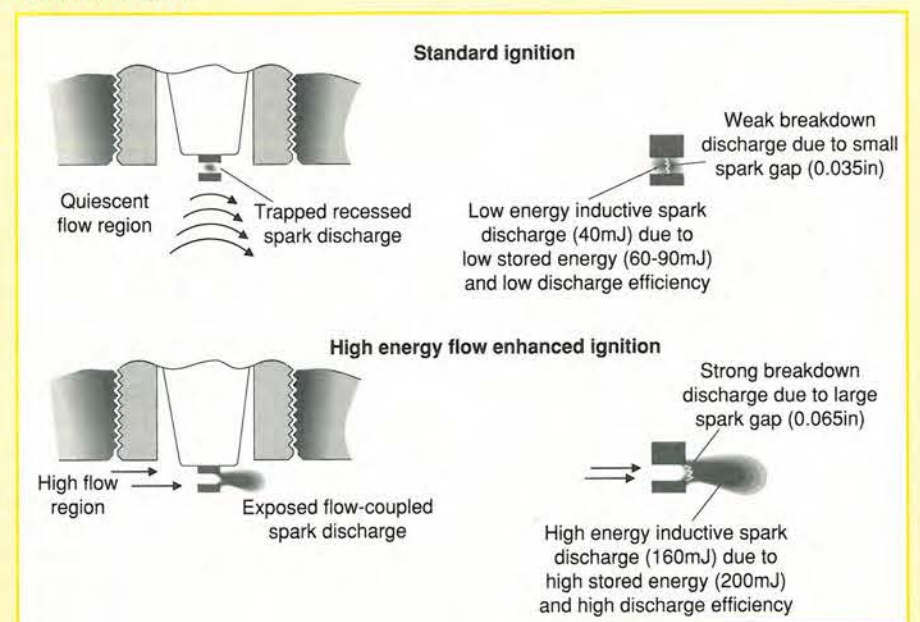

Being deeper in the cylinder and three times more powerful, the spark on the right acts with fuel/air turbulence to become a far more effective igniter than the traditional spark on the left.

Having a large spark well down in the cylinder allows a leaner burn. When a car slows down with its clutch engaged, fuel is sucked into the engine and wasted. Driving around town, this fuel waste is significant. With existing ignition systems, shutting off the fuel during deceleration is problematical because of lean surges during the deceleration-acceleration transition. But the leaner burn of the new system should allow a more complete fuel shut off during deceleration as one of its several benefits.

Tests carried out using the new ignition system on a traditional twin-valve push-rod engine show clear benefits. Could this route to a cleaner, more efficient engine be better than increasing the number of valves and injecting fuel? Note that 1lb/hp-h is the equivalent of 608g/kW-h.

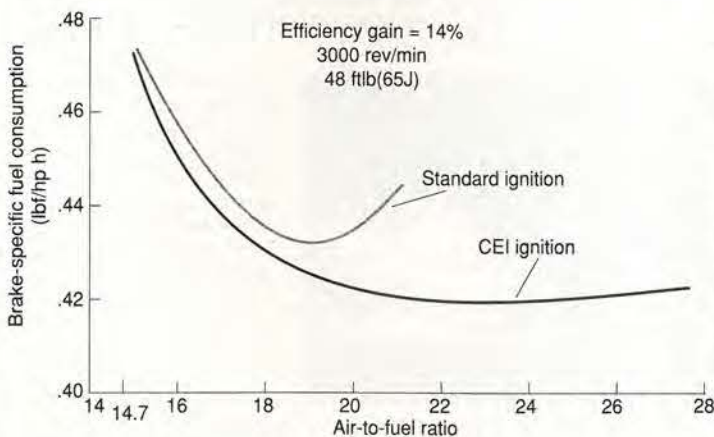
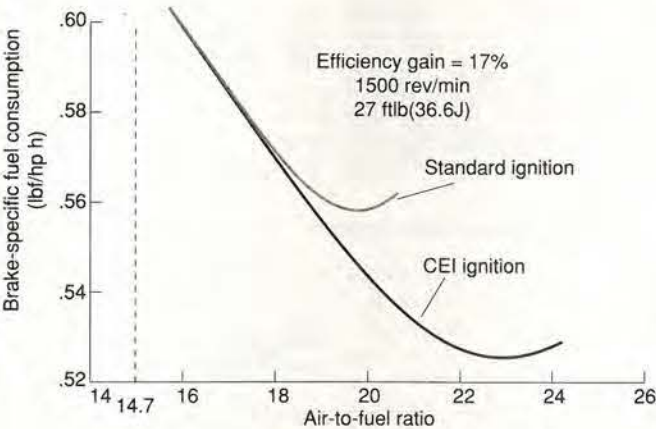
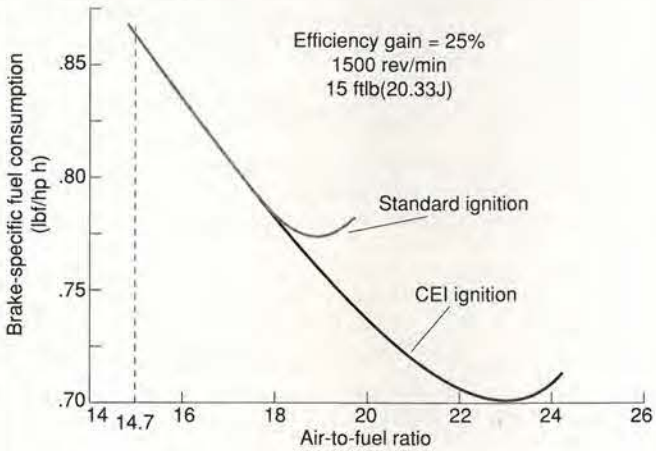
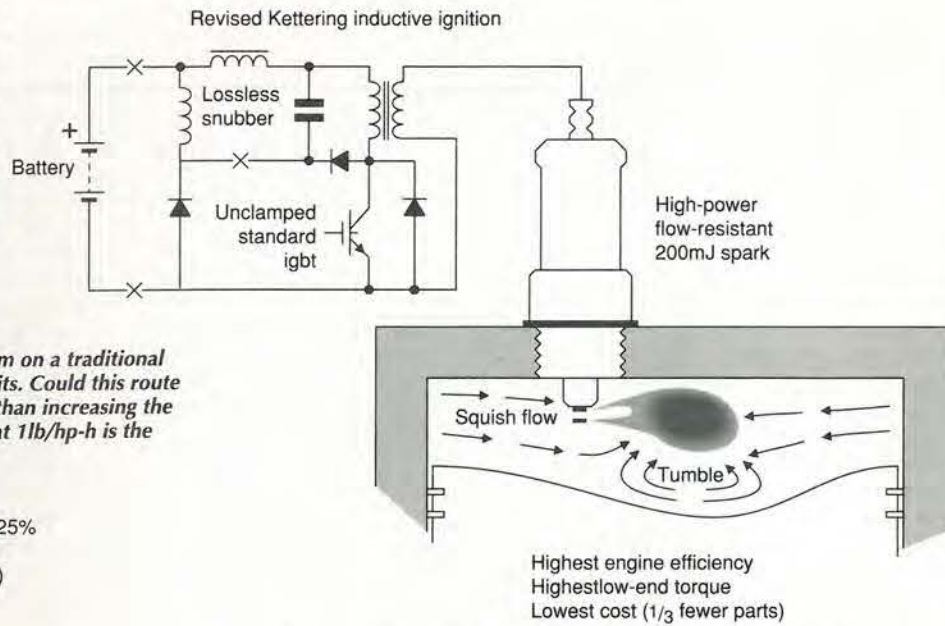

Might we be better off without 16 valves and fuel injection?

The most effective application of the HBI system is with engines that possess some degree of controlled in-cylinder air flow, such as swirl, tumble-flow, or squish flow. Squish flow is the most desirable as it provides high flows at low engine speeds, when combustion is normally poorest.

Unlike the four-valve-per-cylinder alternative, the twin-valve push-rod engine has natural squish flow, making it an ideal candidate. It has powered more cars and trucks than any other engine in the world. And as has been pointed out in the Wall Street Journal, the twin-valve push-rod engine has a third the parts of the four-valve overhead cam engine and it does not suffer the same friction losses in the valve train.

Traditionally, the spark gap has been located in a recessed part of the cylinder for fear of being blown out, or broken-up. With HBI, the ignition spark is positioned in a more central part of the combustion chamber. Here, it is in the squish zone and can be directly coupled to the flow fields to spread combustion efficiently, without the fear of break-up.

In turn, the higher spark voltage associated with the flow coupling will maximise the ignition circuit efficiency. In this way, the maximum of the available, much higher, stored energy is delivered to the flow-coupled spark discharge, as in the drawing.

In tests using an early version of high energy flow resistant ignition on a Ford-Europe engine sponsored by Dr. Tony Jarrett - Group Director of Product Technology for Lucas Industries, Birmingham, England - the air-fuel ratio of the twin-valve push-rod engine tested was improved by three to four air-fuel ratios at low speeds of 1500rev/min and low flows. Gains in fuel economy were substantial, as the graphs illustrate.

At higher speeds, around 3000rev/min, and loads where the flows were much higher, but not sufficient to break up the higher flow-resistant spark, the air-fuel ratio was improved by a remarkable eight air-fuel ratios to provide the lowest possible NOx emissions with significant gains in fuel economy.

The new HBI system, and its equivalent capacitive discharge version which has a comparably high spark energy and even greater resistance to flow-segmentation, can substantially improve the conventional twin-valve push-rod engine. Only a slight modification is needed to place the spark plug at the inside edge of the squish zone.

Such an approach would revitalise the twin-valve push-rod engine and make it competitive with the most advanced high-efficiency engine technologies - including the diesel engine and the recently developed gasoline direct injection (GDI) stratified charge engine. Added bonuses would be a much simpler design and lower cost than either alternative.

This would also be the case for two-stroke engines, which suffer from poor combustion at low speeds.

area. In addition, the coil windings must be designed to have acceptably low primary and secondary resistances R_p , R_s to limit the resistive heat dissipation during coil operation. This prevents the coil from overheating at high engine speeds.

For the same stored energy, current, and winding length, the winding resistances R_p and R_s increase inversely with the fourth power of the coil diameter, increasing by a factor of 16 times when the coil diameter is halved.

More revealing, the primary circuit dissipation during coil energising, E_{dp} , for fixed coil size and peak flux density B_p , is proportional to the cube of the stored energy E_p and inversely proportional to the power delivered to the primary winding. This means that it is inversely proportional to the product of the primary-winding voltage V_p and the current I_p through the winding.

Coil energising time, or 'dwell' time, T_p , is also given below assuming T_p is less than the primary circuit time constant L_p/R_p , recognising that the voltage V_p across the primary winding is less than the supply voltage by the switch voltage drop V_{ce} .

$$E_p = \frac{1}{2} L_p I_p^2$$

$$B_p = \frac{L_p I_p}{N_p A_p}$$

$$E_{dp} = \frac{C \times E_p^3}{V_p I_p}$$

$$T_p = \frac{L_p I_p}{V_p}$$

Higher output - more dissipation

Doubling the stored energy E_p increases the dissipation E_{dp} by a factor of eight. This makes it impracticable to maintain the higher spark energy for the same size coil, supply voltage and peak current, i.e. by increasing the inductance L_p , as is preferred with conventional ignition systems.

Only by increasing the primary power in proportion can the same dissipation be maintained. This is a criterion we choose to use for a properly designed ignition coil - assuming the base coil has been properly designed for heat dissipation.

For the case of a state-of-the-art inductive ignition system of Fig. 1 and ideal coil of weight 200g, the theoretical stored energy E_p is 60mJ, as given below. Assuming a high coil charging efficiency of 60% and spark energy transfer efficiency of 75%, overall efficiency is high, at 45%. Resulting spark energy E_s is 45mJ.

Typical parameters for such an inductive ignition system are given below, where a peak magnetic flux density B_p of 1.4 tesla is assumed as the practical maximum value for standard ignition. This assumes a magnetic core material of silicon iron.

The charge or dwell time T_p is calculated at full battery voltage of 13.7V, or V_p of 12.4V assuming a switch drop V_{ce} of 1.3V.

- $L_p=2.4mH$
- $I_p=7A$
- $A_p=1.2cm^2$
- $N_p=100$
- $N=90$
- $B_p=1.4T$
- $E_p=60mJ$
- $E_s=45mJ$
- $T_p=1.4ms$

Doubling the stored energy E_p to 120mJ and maintaining the same dissipation E_{dp} requires that the break current I_p be raised from 7A to 56A for the standard inductive ignition powered by the car battery. Even assuming state-of-the-art logic-level switching 400V igbts with low saturation voltages, this remains impracticable in view of the high switching losses.

Switching losses are proportional to the peak current I_p and increase further with temperature. The higher switching losses would be a source of further internal heating of the igbt which would not be tolerable in the high temperature environment of the engine compartment.

Losses due to switching can reach 60mJ - or half the stored energy - offering no improvement in energy delivery. Moreover, even if you could attain the spark energy of 90mJ, you still have a 60mJ energy shortfall relative to the minimum 150mJ requirement.

Peak spark current I_s , of 620mA, would also be higher than desired. Without some significant change in strategy for inductive ignition, it is not possible to meet the competing goals of one-coil-per-plug ignition with very small coils, and the need for high spark energy for improved fuel economy, within the additional constraints of acceptable costs and other preferred features.

A new approach to ignition

The equation for dissipation E_{dp} suggests the direction needed to be taken. It is necessary to make the system independent of the battery voltage - assumed to vary between 6 and 14V.

It is also necessary to raise the voltage V_p , or generalised supply voltage V_c to a higher value of approximately three times maximum battery voltage. A value of 42V is represents a good compromise between an even higher voltage V_c and a value required to limit the output voltage upon switch closure to prevent false firing of the spark plug.

By using the moderately high operating voltage of 42V, then a higher primary current I_p of approximately 30A can be used. A proviso is that a snubber circuit needs to be included to reduce the otherwise high switching losses at the higher current I_p .

Proper design of the snubber allows for a best trade-off between conduction losses and switching losses, to the point where conduction losses dominate to allow for the use of the lowest cost, standard speed igbt, versus more expensive fast or ultra-fast devices.

Table 1 shows measured values of switching and conduction losses of 600V standard speed and fast igbts under operating conditions, i.e. with a peak current I_p of 30A, a stored energy E_p of 200mJ, and a peak snubber capacitor voltage of 440V.

As is clear from the table, conduction losses dominate, suggesting use of the standard speed igbt. Among such devices, there are two choices. One is the present logic level, 400V, 15 or 20A voltage-clamped, n-channel ignition igbt. The second is the 600V, 20A, unclamped n-channel general purpose igbt.

In the case of the 400V ignition igbt, the coil turns ratio N and snubber capacitor would be adjusted to accommodate the peak voltage of 400V.

The 400V alternative has three main advantages. Firstly it has a low drive requirement of only 5V for a peak current I_p of 30A. At this level, collector-to-emitter voltage drop V_{ce} is only 2.5V. Secondly, the 400V igbt has a low V_{ce} of only 2.0V at 30A at the battery rated drive of 12V. And finally, its internal 400V clamp allows greater flexibility in use of the device including placing it at remote locations such as on the ignition coil.

The 600V general-purpose igbt also has several advantages. Its collector-to-emitter voltage V_{ces} is high, at 600V, and it has a low V_{ce} of 2.5V at 30A at the battery rated drive of 12V for

Table 1. Measured switching and conduction losses of standard and fast igbts for a peak current of 30A, stored energy of 200mJ and 440V peak snubber capacitor rating.

Device	Conduction loss	Switching loss	Total losses
Fast igbt	26.9mJ	10.2mJ	37.1mJ
Standard igbt	22.4mJ	12.4mJ	34.8mJ

Fig. 2. Circuit of the new high-power ignition system uses standard low-cost components to produce a spark with over three times more energy than that of a conventional system. The spark also has a higher flow resistance, allowing it to be initiated deeper in the cylinder, resulting in more efficient combustion and a cheaper engine design.

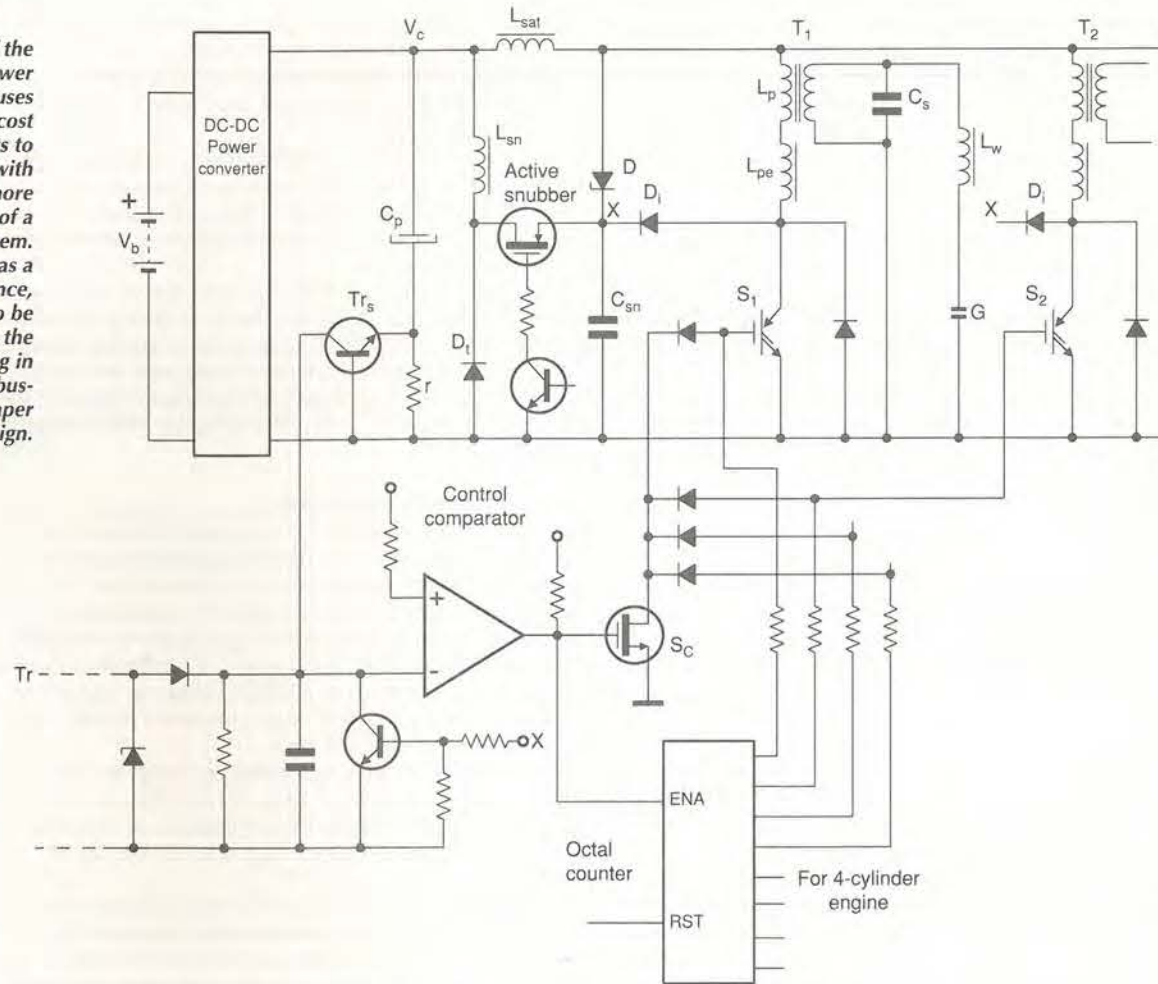

fourth-generation devices. This igbt also exhibits fast switching, of 1 to 2µs, at high junction temperatures of 150°C. It has the lowest number of masks and few critical alignments in the manufacturing process, resulting in high yields and low cost.

No clamping necessary

For the application involved here, the internal clamp of the ignition igbt is not necessary. A snubber circuit is used with a single external clamp. Neither is the low switch drive required, as a result of the higher available voltage V_c under all conditions – including 6V engine cranking.

On the other hand, the 600V rating of the general purpose igbt allows for the use of lower coil turns ratio N of 75 instead of 90 and provides higher output voltage of 42 versus 36kV. Also, its switching time is acceptably fast as seen above.

The lower turns ratio reduces the peak output voltage upon switch closure and reduces the number of coil secondary winding turns. This allows a heavier, lower cost wire and an easier to wind secondary to be used. In addition, the cost of the general purpose 600V, 20A, standard switching speed igbt, quoted at under \$1 a unit, is lower than that of the 400V igbt.

As a result, the general purpose igbt is the preferred candidate for this particular application. But note that in other ignition applications, the low drive and internal clamping of the 400V ignition igbt may make it the device of choice despite its higher cost. Such applications are the coil with integral switch, and a new ignition application developed by us that is yet to be announced.

With the general purpose 600V igbt, a saturating inductor and a low-loss active snubber, it is possible to achieve an energy storage two and a half times times the value of 60mJ. A further effective increase of 20% to three times the energy, or 180 mJ, is possible as a result of certain parallel improvements in coil design arising from a new approach, discussed later.

Ignition circuit details

Analysis of the HBI system features, shown in Fig. 2, begins with the supply capacitor C_p . It is charged to voltage V_c by the power converter, and is typically made up of two or more high-efficiency, high-temperature electrolytic capacitors which store many times the coil energy.

Included in the capacitor is a current sensor advantageously located at its low end, with a simple form of current sensing system. This sensor is based on a resistor and n-p-n transistor Q_s whose base-emitter junction is across the sense resistor with grounded base. The base-emitter junction voltage V_{be} decreases with temperature to provide a preferred lower current and energy with temperature to conform to typical engine ignition requirements.

The next relevant component is the low-cost saturating inductor L_{sat} . In combination with the low turns ratio N and preferred large spark gap made possible by the higher output voltage, this inductor eliminates the problem of false firing of the spark plug upon switch closure. False firing is aggravated by the higher voltage V_c .

The inductor is designed to have an initial inductance approximately equal to the coil primary inductance L_p , and then made to drop rapidly with current to an inductance of one order of magnitude smaller. Its function is to reduce the high-frequency peak voltage $V_{s(0)}$ upon switch closure, equal to $2N \times V_p$, to one half its value, Fig. 3.

This high-frequency, voltage doubling effect was discovered and mathematically analysed by us in 1989 (see references).

Assuming a lower turns N of 75 through use of the 600V igbt, the output voltage reaches a peak value of only 3000V on switch closure. This is less than the minimum spark gap breakdown voltage.

Our HBI coil has a short energising or charge time T_p of

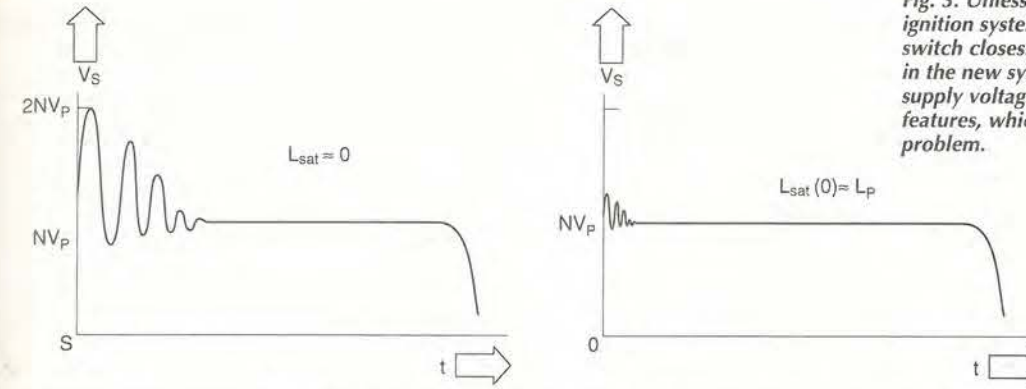

Fig. 3. Unless counter measures are taken, in an ignition system, false firing can occur when the switch closes. This problem would be aggravated in the new system due to the significantly higher supply voltage, were it not for L_{sat} and other features, which completely eliminate the problem.

approximately 400µs versus 1.5 to 5ms for standard ignition. Because of this, the time of switch closure will occur later in the engine compression stroke at a higher cylinder pressure to further reduce the possibility of false firing.

The preferred larger spark gap of 0.060in made possible by the higher output voltage of the HBI system also helps reduce false firing – i.e. sparking upon switch closure. Moreover, energy associated with the saturating inductor at the end of the charge time is not wasted, but returned in large part to the power supply by the low loss active snubber discussed next.

Low-loss active snubber

The third key circuit feature is the low-loss active snubber already mentioned. It reduces switch-opening losses and provides other benefits.

The snubber is made up of isolating diode D_i , snubber capacitor C_{sn} , a p-type fet switch, snubber inductor L_{sn} , and return diode D_f . It serves two main functions. First, it smooths and lowers the high-voltage transient that occurs when the switch opens. This transient is associated with the energy remaining in the saturating inductor and in the coil leakage inductance. It delivers the energy onto the snubber capacitor, minimising switching losses and electromagnetic emissions.

Secondly, the active snubber delivers most of the energy stored on the capacitor back to the power supply. This minimises clamp, switch, and resistive losses, as well as raising the ignition system efficiency, in turn reducing demands on the power converter to maximise system efficiency.

The snubber capacitor is selected to reach a peak voltage V_{sn} less than the clamp voltage V_{cl} , from transfer of the circuit leakage energy to the capacitor. Typical ignition parameters for the HBI system operating at the preferred 42V (V_c) are,

- $L_p = 0.4mH$
- $I_p = 32A$
- $A_p = 1.35cm^2$
- $N_p = 60$
- $N = 75$
- $B_p = 1.55T$
- $E_p = 200mJ$
- $E_s = 150mJ$
- $T_p = 0.35ms$

A higher core area is assigned to the HBI system to compensate for its smaller coil size, Fig. 4. In addition, a higher flux density is assigned due to a better lamination design and the larger effective air-gap which allows for greater stressing of the core.

Peak current drawn from the battery is comparable to that of today's inductive ignitions, ranging typically between 5 and 10A. It has a very low ripple resulting from using a fast-switching power converter design.

Controlling the switch

To complete the HBI system, a particular simple and low cost form of switch controller and driver has been developed, Fig. 2.

Assuming multiple switches for one-coil-per-plug ignition,

the controller holds the gates of ignition coil power switches low. It does this by means of an n-type fet switch S_c , whose drain interconnects the igbt gates through isolation diodes.

On ignition firing, i.e. the controller receiving a conditioned trigger signal at the inverting input of a control comparator, control switch S_c is turned off. This enables the gates of the igbts and sequences an octal counter.

The counter provides a turn-on signal through a resistor to one of the igbts to begin energising its associated coil. This continues until the set peak current I_p is reached. At this point, sense transistor Q_s is turned on, pulling the comparator inverting-input low and turning on control switch S_c .

Control device S_c disables the switches by rapidly discharging the igbt input capacitances C_{ies} for rapid turn-off of the energised switch. It also disables the remainder of the igbt switches.

Supply voltage for the octal counter is derived from the output voltage V_c . This is because there would not be enough voltage to drive the gate of the igbt at the lower battery voltages encountered in automotive systems during cranking.

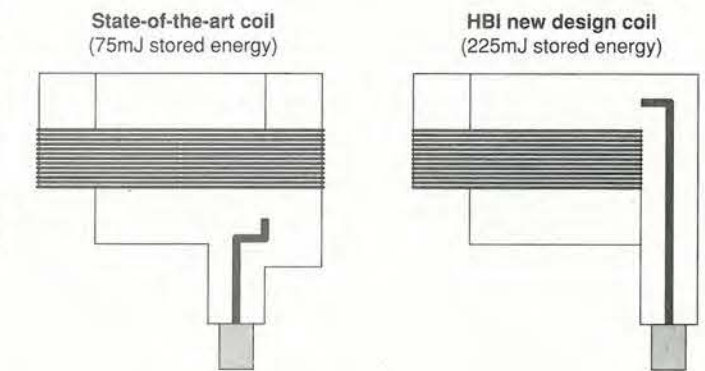

Fig. 4. State-of-the-art coil on the left has a two-piece welded core, 10000 turns of 42AWG secondary and a difficult-to-implement HT terminal. The new coil on the right has a one-piece E core, 5000 turns of thicker, easier to wind wire on its secondary and provides easier access to the HT end of the secondary. Benefits are,

- One piece lamination requiring no welding and easy packaging.
- 20% lighter weight coil due to the open E design.
- 40% lower primary wire turns, i.e. 60 versus 100 turns, ideally suited for a two layer winding.
- 50% lower secondary wire turns and use of 36 versus 42AWG wire which is much cheaper and easier to handle on a winding machine (less breakage) and takes half the time to wind.
- 20% lower cost due to the above listed advantages despite the three times higher energy.

Performance with low-volatility fuels

Once this new strategy for inductive ignition is realised, numerous advantages follow. A particularly interesting one is the ability to fire the ignition with closely spaced high-energy spark pulses under engine cranking conditions.

Long-duration spark firing during cold start is possible due to the rapid charge time T_p , which is an order of magnitude shorter than that of conventional inductive ignition. A much higher spark energy and longer spark duration are provided. This allows the ignition of lower volatility fuels, such as further reformulated gasolines, neat alcohol, JP5 fuel – used because of its reduced fire hazard – water-gasoline mixtures, and others.

Low volatility fuels can have a major impact on volatile organic compound, or VOC, emissions. As cars become progressively cleaner and tail-pipe emissions are reduced, evaporative VOCs become the principal hydrocarbon emission.

Evaporation of fuel upstream of the engine is projected to account for approximately 80% of the total VOCs from new cars sold in California in the year 2003. The remaining 20% will come from the tail-pipe. Ignition of low volatility fuel can be accomplished even at low battery voltages of 5 to 6V. Such voltages occur in extremely cold climates during engine cranking.

In addition, 4kV diodes may be used at the coil secondaries, allowing for even closer spaced spark firing pulses, further improving cold-start capability. Such diodes are cheaper to implement than the 8kV types.

To take full advantage of the low-cost, high voltage diodes, high inductance magnetic core spark plug wire is preferred to limit peak spark breakdown currents to under 10A. Use of such wire also reduces electromagnetic interference.

Other advantages of the new system

A particularly important advantage of the HBI system is the development of a simpler and lower cost coil resulting from the low coil primary inductance dictated by the new approach. The low inductance permits use of single open E-core coils versus the two piece welded design shown in Fig. 4.

When considering the benefits mentioned in Fig. 4, keep in mind that new coil delivers around 150mJ of spark energy versus approximately 50mJ for the current inductive ignition.

Table 2 compares ignition characteristics of the HBI system against various standard and state-of-the-art ignition systems. These were measured, in part, by a reputable car manufacturer conducting testing of the various ignition systems.

Where biasing magnets in the magnetic cores are needed to reduce size, this can be done more easily with the HBI coil because of its larger inherent air gap, retaining its three times higher energy density over the standard inductive ignition.

Unexpected benefits

There are other significant advantages than that of the ignition coil which follow from implementation of the HBI system. Most of these were not anticipated at the outset of the work to develop the HBI system and therefore only add to the motivation for use of this new system.

- Higher peak voltage to allow use of larger spark gap to further improve ignitability.

- Greater resistance to spark plug fouling due to the much lower inductance, faster rise times, and higher energy.

- Elimination of the need for computerised dwell – making the ignition universally retrofittable.

- Elimination of power switch (igbt) operation in the linear mode with its high dissipation and possibility for destructive oscillations due to unstable feedback loop in linear mode.

- Lower overall switch dissipation despite the much higher energy and peak currents as a result of the rapid charging of the coil and use of the low-loss snubber.

- Higher spark current characterised by higher spark power and greater resistance to spark segmentation by the high engine flows in modern high-output engines

Three important questions remain regarding the new HBI system – what is the system cost, can it easily be implemented on a typical four-cylinder engine and what fuel efficiency gains can be expected?

Cost comparison

System cost can be analysed in a preliminary, general way by comparing costs of the three new critical systems of HBI against cost savings associated with the power switches and ignition coils. This assumes that biasing magnets are used in the coils of the conventional inductive ignition to bring its spark energy to 100mJ – a value which is still short of the 150mJ offered by the new system.

From data on switch costs, savings of \$1 to \$3 are achieved based on the prices quoted for the 400V, 20A ignition igbt which would be required for the improved standard ignition, versus that quoted for the 600V general purpose igbt. For the new ignition coils, 20% reduction results from the use of one piece lamination, half the number of secondary turns, 36AWG wire versus 42AWG, and removing the cost of biasing magnets.

The estimated overall cost savings are equal approximately to the cost of the additional components making up the HBI system. That includes the power converter with its input filtering capacitors, output capacitors, the transformer, the fet switch, and output diode. It also includes the saturating inductor, the active snubber and various other low-cost components.

Elements of the HBI system, i.e. power converter, saturating inductor, and the low-loss snubber, and the associated igbt switches can be mounted in the controller box. Preferably though, they would be mounted in a separate box located near the ignition coils, but sufficiently remote to avoid overheating.

On the other hand, predictions have been made by Kassakian (MIT), Wolf (Mercedes-Benz), Miller (Ford), and Hurton (G.M.) as reported in *IEEE Spectrum*, August 1996, that 42V will be made available in the passenger car engine compartment for operating motors and actuators. If this is the case, the HBI system can be fully integrated with an equal cost or cost savings despite its numerous advantages and benefits.

Fuel economy

On the issue of improved fuel economy, with high-energy ignition, extensive experience over a 20 year period – which has included testing at GM, Mazda Motors, Lucas Industries, and Chrysler Corporation – has shown fuel economy to be improved by up to 20%. This is based on dilute combustion, principally lean burn.

Typically, the fuel economy gains would be largest under light load where air-throttling losses are high, and minimal at high loads. A conservative estimate over the typical driving cycle is 6% assuming air dilution is used at the light loads where NOx is low, and EGR is used at the higher loads where NOx is high.

Table 2. Comparison between standard, state-of-the-art and HBI ignition systems reveals high energy output and efficiency of the new system.

Ignition	Inductance	Resistance	Spark energy	Coil weight	Efficiency
HEI	6.6mH	0.4/9500Ω	40mJ	750g	<20%
Waste Spark	3.5mH	0.4/6000Ω	35mJ	260g	25%
Make 1	3.0mH	—	60mJ	265g	—
Make 2	2.5mH	0.6/—	50mJ	190g	35%
Make 3	2.8mH	0.7/7800Ω	50mJ	210g	35%
HBI	0.4mH	0.15/500Ω	150mJ	200g	50%

These figures assume a full implementation of the HBI system which includes, in addition the electronics described, a larger spark gap and better penetration of the spark plug tip in the combustion chamber. Placing the plug deeper in the cylinder allows the spark to interact more fully with the high in-cylinder air flows, resulting in higher output at cold start, etc.

A 6% improvement in fuel economy on an average of 25 miles per gallon would bring the mileage closer to the current CAFE standard of 27.5 miles per gallon – a target which car companies are currently missing. It translates to a 1.5 miles per gallon improvement, or a saving in CAFE penalties of \$75 per vehicle – a far greater cost than any additional cost associated with the HBI system.

In terms of gasoline savings over the life of a car, assumed at 125 000 miles, this comes to a savings of 300 gallons of gasoline, which in the US would amount to \$400 based on a fuel price of \$1.33 per gallon and in Europe and Japan to \$1000 based on a price of \$3.33 per gallon. Even the smaller cost savings in the US would be well over ten times the projected additional small cost increase of the HBI system.

In summary

A new form of inductive ignition system has been developed which provides the required three times higher energy density of state-of-the-art inductive ignition systems and numerous other benefits not initially anticipated when this development program was begun some two years ago.

This new inductive ignition uses a higher, independently generated, constant voltage source of 42V – the value projected as

best suited for other vehicle systems. It incorporates a standard speed, low-cost, 600V general purpose unclamped igbt as the switching element. It also uses a low cost saturating inductor to handle the switch closure false-firing problem and an active low loss snubber to minimise switching losses, rfi and system heating, as well as maximising system efficiency.

Complementing the system is a unique, low cost, 85% to 90% efficiency high-output power converter based on the use of state-of-the-art low cost 60V fets, a ferrite core transformer, a 150V ultra-fast output diode, and a simple form of controller made up of a dual comparator.

Applied to current engines, HBI provides the small, high-energy coils of the one-coil-per-plug ignition the industry seeks, and a range of other benefits. These include short dwell time, fast rise-time, resistance to plug fouling and high efficiency.

More importantly, given the current growing concerns over fuel efficiency and emissions, HBI has the potential for up to 10% improvement in fuel economy and large savings in capital investment to car manufacturers willing to revitalise their current power plants – such as their twin-valve push-rod engines – to make them cleaner and more efficient.

My thanks to Dr Tony Jarret of Lucas Industries and Joe Franklin, both of London, England, for their unwavering support of this work.

Reference

Ward, M, 'A new spark ignition system for lean mixtures based on a new approach to spark ignition,' Society of Automotive Engineers' Technical Paper Series, No 890475, Warrendal, PA.

A Powerful 12Bit Virtual Measuring Instrument For The PC

Four integrated instruments are giving you all the possibilities for different kind of measurements and good documentation features NEW



OSCILLOSCOPE

Special developed controls make controlling the oscilloscope very easy and intuitive.



RECORDER

With the transient recorder slowly changing events, like temperature, can be measured.



FFT ANALYZER

Spectra with records of 8K long and 6 window types. Simultaneous display of the signal in the oscilloscope and spectrum analyzer.



CURSOR READOUT

For each channel there are two cursors. With the cursors several quantities of the signal can be measured.



VOLTMETER

The voltmeter has up to six fully configurable displays. A bar graph is added to each display for a quick signal size overview.



DOCUMENTATION

To document the measured signals an option to place text balloons is available. In each text balloon specific text can be placed.



€ 299.00
COMPLETE SYSTEM

Handyscope 3 specifications: 32KWord memory, 100% pre- post triggering, 12 bit resolution, 200 kHz sampling on each channel, 0.1 to 80Volt full scale, no external power supply, connected to printer port. Price are excluding VAT

TiePie engineering (UK): 28 Stephenson Road, Industrial Estate, St. Ives, Cambs, PE17 4WJ, UK Tel: +44 1480 460028, Fax: +44 1480 460340
TiePie engineering (NL): P.O. Box 290, 8600 AG SNEEK, The Netherlands, Tel: +31 515 415 416, Fax: +31 515 418 819.
Call for a free demo disk or see our website: <http://www.tiepie.nl> Email: info@tiepie.nl

Hands-on Internet

Cyril Bateman presents tips for speeding up your searching and downloading, and an update on circuit simulation software.

Internet provides designers with the ability to locate then download sources of needed information into a personal computer. Tracing through random links can sometimes be surprisingly successful, but methodical use of a search engine is more reliable.

Benefits of the net are maximised by quick search responses and fast download times for Web pages or files.

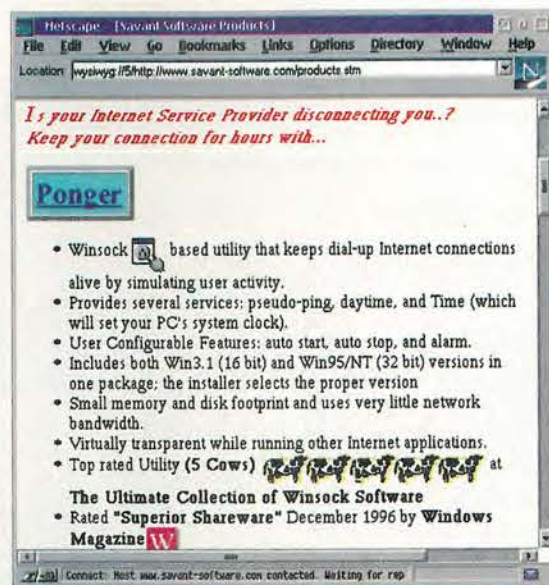

Fig. 1. 'Ponger' is designed to help maintain your Internet connection to prevent aborted file loads and the like. If moving your mouse or sending 'Pings' improves your connection, try this utility.

Internet access can be extremely slow during peak times, and of late, this slowness is extending well outside the peak periods for many popular sites.

Traditionally, one sent a 'Ping' to check that an address was 'on-line'. I now find sending regular 'Pings', say one a second, can help in maintaining my route. A utility called 'Ponger', which runs on Win3.1 or Win95, can be obtained from Tucows¹, the specialist Winsock archive, to automate this task, Fig. 1.

Two years ago relatively few Web pages existed, so today's popular search engines had not been devised. Archie, Gopher, Veronica and Wais² were the methods then used to locate sources. FTP was the only practical method available to download files from Internet.

One year ago, Java applets and the Netscape2 browser were introduced. Direct software downloads using a browser became commonplace, effectively supplanting use of FTP. As the numbers of Web pages increased, the AltaVista, Excite and Infoseek keyword search engines were developed to supplement the older directory searching methods.

There has since been an explosion of Web pages, to the extent that some companies now host 1000 Web pages on their site. This rapid expansion has resulted in major changes to all search engines – the largest now maintaining indexes covering more than 50 million Web pages and more than two-million URL site addresses.

This enormous increase of activity is linked to the trend towards larger and more glossy corporate Web pages,

large graphical images and extensive use of Java applets. My present Internet access speed is frequently no faster using a V34 modem than it was two years ago with slow hardware. A recent and growing tendency for links to work initially quite quickly then slow considerably – or worse, simply drop out – has become apparent when downloading Web pages or transferring files.

In the November issue, I reported on the new Micro-Cap V software. I abandoned several attempts to download the 1.7 Mbytes evaluation version³ because my Netscape browser closed down the transfer before completion of the file. On one occasion this happened when the transfer was more than 90% complete.

One obvious solution is to use a traditional FTP client, but FTP from a Web page is only possible if that page provides an FTP address. Having only an http link, my FTP client could not be used to download the Micro-Cap V software file.

When a browser download slows or stalls, requesting a second download which you immediately cancel, often seems to 'wake-up' the route. Sending regular 'Pings', even continuously moving your mouse, sometimes helps maintain the route. Combining these techniques, I completed the download.

The Software Explorer page⁴ recently reviewed a potentially better transfer method for browsers. The 'GetRight' utility is a mini FTP client add-on which can even permit resumption of a broken transfer. Windows 3.1 users should first read the special instructions on the Headlight Software⁵ page.

Routing

Internet's growth has resulted in two aspects contributing to these problems. You may have noticed that the time taken by your browser to look up Internet addresses has increased. These addresses are stored in increasingly large subnet tables on dedicated servers, used to determine the routings used.

Transfer from the Web server to your computer does not happen in a direct fashion, but as a number of 'hops'. Each hop determines the next hop location. Of course Internet uses many supplementary routes, rather like having a number of bucket chains, with each handler passing its bucket to whichever chain is next ready to accept.

A secondary problem results from data packets queuing at these routers. When their buffer memory overflows, routers lose data packets. Packet loss is an increasing problem, thought to result in e-mails going missing and to contribute to file transfer problems. While not generally relevant, any data packet which requires 255 or more hops to reach its destination, is automatically killed.

'Ponger' and 'GetRight' are palliatives. A diagnostic approach is needed to identify whether problems are caused by Internet, your provider or your phone line or hardware. Most modern operating systems provide usable utilities. 'Ping' has already been mentioned; Traceroute, IPTrace and TCPdump, or variations on these names, can help.

Traceroute can identify your outgoing Internet routing, but the return route might be quite different. 'Traceback' is a more difficult problem when running from your own computer, but it can be run using software at the NCDC site.⁶ My recent test indicated 18 hops were needed from Spectrum-Soft, several packets were lost and seven routings delayed, Fig. 2.

NetMedic⁷ is an excellent diagnostic utility and Internet tuning aid for Win95/NT. Its 'hop' monitor can

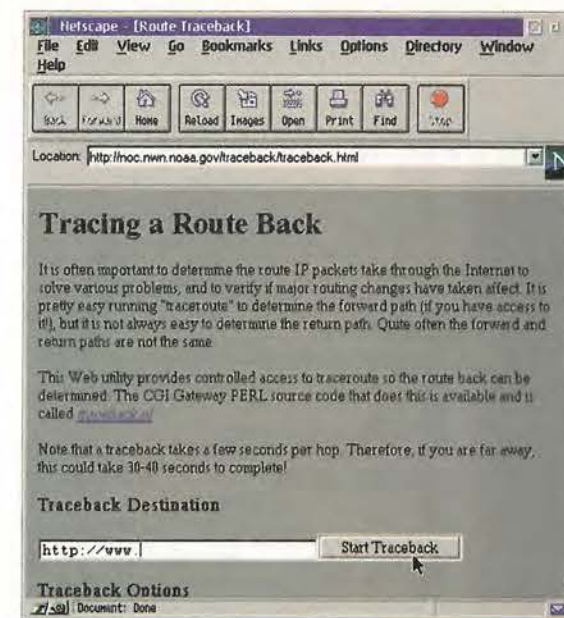

Fig. 2. If slow transfers bug you, route tracing can highlight problems. Find out how many lost packets and exactly where your delays occur.

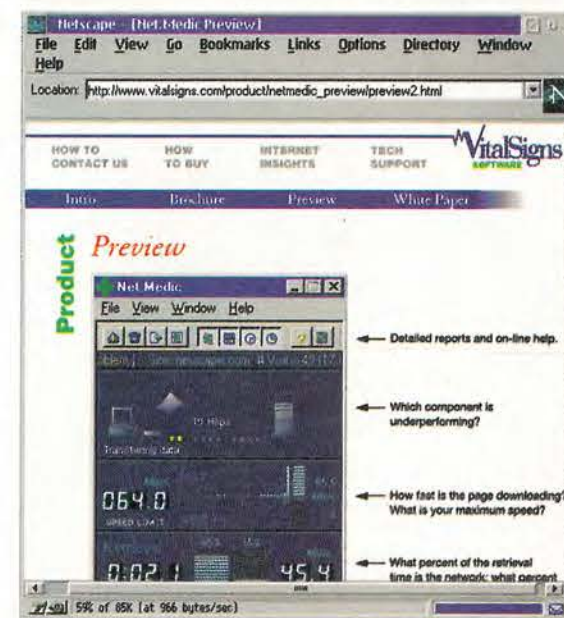

Fig. 3. 'NetMedic' provides short term and diagnostic long term logging of on-line problems. Using Win95 or NT, find where and when your Internet response problems occur.

be installed onto Netscape's toolbar, for continuous use, Fig. 3.

Search engines

Launched in May 1996, HotBot is Wired's entry into the search engine market. It uses Inktomi technology and has more than 50 million Web pages indexed.⁸ It provides an easy menu selection for your desired search parameters, Fig. 4.

LookSmart⁹, launched by Reader's Digest in October 1996 using AltaVista technology, was redesigned in June this year and provides two search modes. Clicking on one of the border categories reveals more menu selections, thus combining the AltaVista keyword virtues with a simplified directory search.

More bugs

Following on from last months WinNuke problem, two bugs, affecting Microsoft or Netscape's browsers have been reported. News.Com¹⁰ reports of 5 and 11 September detail the bug discovered by the Massachusetts Institute of Technology. This problem affects Microsoft's Explorer 3, and its beta 4 version, software. It results from the Java

Where to surf

1. The Ultimate Collection of Winsock Software. <http://tucows.ip.pt>
2. Surfing with intent. C. Bateman. EW&WW June 1995
3. Micro-Cap V version 2.0 <http://www.spectrum-soft.com/down/demo.zip>
4. Software Explorer <http://www.windowscentral.com/reviews/internet/getright>
5. Headlight Software. <http://www.headlightsw.com>
6. Tracing a Route Back <http://noc.nwn.noaa.gov/traceback/traceback.html>
7. Vital Signs Net.medic http://www.vitalsigns.com/product/netmedic_preview
8. HotBot Search Engine <http://www.hotbot.com>
9. LookSmart Search Engine <http://www.looksmart.com>
10. News.Com <http://www.news.com/News>
11. PCWeek Online. <http://www8.zdnet.com/pcweek/news>
12. Demo of Browser Security Hole http://neurosis.hungry.com/~ben/msie_bug
13. Number One Systems Ltd. <http://www.numberone.com>
14. Mental Automation Inc. <http://www.mental.com/SUPERCAD.HTM>

Fig. 4. HotBot - Wired's search engine - now indexes more than 50 million pages. Offers easy search control to finds results others miss.

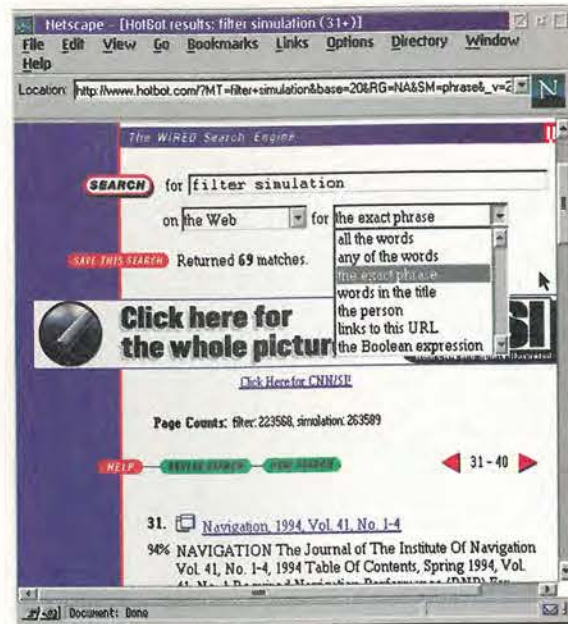
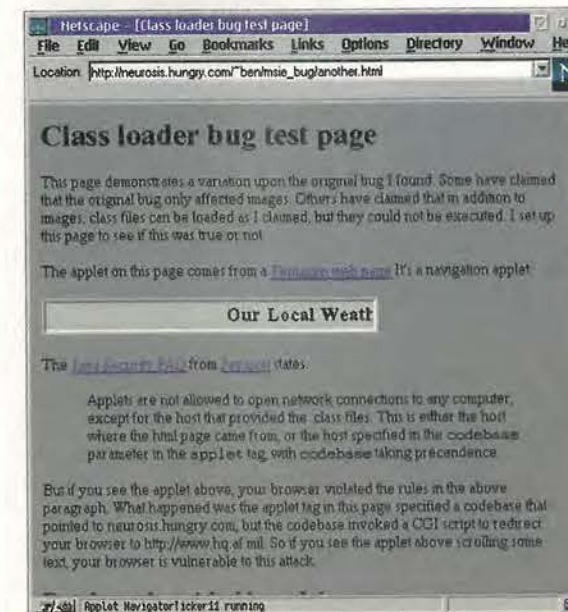

Fig. 5. Essential reading if you use IE3.0 or IE4 beta browsers. Macintosh users are not affected but Windows users should install the final Explorer4 version.



Fig. 6. Java applets cannot open connections to other hosts - or can they? Prove or disprove your browser's Java security in the safety of this test site.



methods used within the browser, not a function of Java itself, Fig. 5.

A *PC Week* article¹¹ dated 12 September details that Microsoft is actively removing all Java applets from its Web sites. This is apparently part of a campaign to speed up the downloading rate for its pages. Where needed, Java applets will be replaced by HTML code or Javascript.

The second bug, discovered by Ben Mesander and reported by *News.Com* 8 and 12 August, affects both Microsoft and Netscape browsers. It can be demonstrated using Ben's¹² test page which houses two demos, demonstrating the two variations.

Ben first uses a harmless applet to redirect and download an image from Microsoft's pages. For security, Java applets are only permitted to communicate with their host page, so should not transfer this image. I tried my machine, which passed this test.

Ben's second test demonstrates the 'Class Loader Bug'. In this test, the applet tries to download a harmless text 'ticker' again by redirection, from <http://www.hq.af.mil>. I also tried this out on my system, running Netscape 2.02 under OS/2 Warp4, and failed this test. The running ticker can be clearly seen.

While Ben's tests were deliberately designed to be harmless, others could as easily use these techniques, to cause harm, Fig. 6.

Simulation and design software

Not all circuit simulation software is based on Spice. Many vendors specialise in providing frequency-domain-only simulation to extremely good effect.

One such system originates from Number One Systems¹³ - a long established UK developer. My very first commercial simulator was their original *Analyser* of 1983, running on the *BBC model B* microcomputer.

Since then I have regularly relied on the company's Windows suite of integrated packages, for quick look-see simulation and final pcb design. Number One's unique *Layan* simulator is able to extract printed circuit layout traces as circuit elements. These combine with conventional elements for *Analyser* simulation. If desired the results can be exported seamlessly to their Smith-chart program.

If you are looking for a low-cost, easy-to-use integrated suite of Spice based simulator, schematic editor and pcb layout tool, which you can download and evaluate before purchase, *SuperCAD* from Mental Automation¹⁴ is worth a look. The company's *SuperSpice* simulator displays results using a virtual oscilloscope like display, having volts/division adjustment for each of four traces. Mental claims its *SuperCAD* schematic editor is fast becoming an industry standard.

Circuit applications

The Mc Graw-Hill Encyclopedia of Electronic Circuits is a cd rom containing 1000 circuit designs taken from industry leaders.

Also developed by Mental Automation this rom is based on the popular six-volume book series from Mc Graw-Hill and the circuits used were selected by the original author of the series, Rudolf Graf. Each circuit can be viewed or printed out using the supplied schematic viewer or can be edited with the *SuperCAD* schematic editor.

ELECTRONICS WORLD

INCORPORATING WIRELESS WORLD

Electronics World incorporating Wireless World is applied electronic design. We'll show you how to use the latest silicon technology plus...

- ✓ CAE software
- ✓ New product reviews
- ✓ Technology reports
- ✓ Detailed circuit diagrams
- ✓ Innovations
- ✓ Explanations of complex technology
- ✓ Comment and much more in your issue.

Money back Guarantee.
Receive a full refund on your subscription within the first 90 days if you are not completely satisfied. Thereafter, we'll refund the unused portion of your subscription should you wish to cancel.



So whether you are designing your own system or you're curious about your competitors, *Electronics World* will help you keep the leading edge.

SAVE UP TO 10%

MI407-01 Pin diode up to 800MHz/25W £1.21

Many other frequencies/ power combinations available, please call with your requirements. Data sheets available for specific items on request.

Call for Amateur/ Education discounts or volume pricing

COMING SOON - Linear power amplifier 'Starter Packs' for 2M & 70cm. **MITSUBISHI ELECTRIC**

TDC also stock Modem, Networking and GPS receiver and antenna products, visit our web site at <http://www.tdc.co.uk> for more information.



Telephone : 01256 332800 Fax : 01256 332810
e-mail : sales@tdc.co.uk

Access/Visa accepted, prices include VAT @ 17.5%, Postage & Packing £5

CIRCLE NO. 115 ON REPLY CARD

's PC Converters monitor and record temperature and humidity'.

MicroMon Temperature / Humidity Logger & Alarm System

MicroMon has many applications in: food processing - storage and distribution, energy management - waste energy, heating and processing, agriculture - monitoring humidity in greenhouses, and in hospitals - accurate monitoring of temperature sensitive items.

Monitors up to 30 channels of temperature over a 400 m. distance. -55 to 100°C temperature range (typical accuracy ±0.2°C). Data can be downloaded to PC.

MicroMon Temperature Kit from £393.00
Temperature Sensors on 5m lead, 3 channel printer, Enviromon Logger, cables & fittings. Available at any time for around £50 / channel

TC-08 8 channel Thermocouple to PC Converter

Simple to use thermocouple to PC interface.

- ▼ Connects to serial port - no power supply required.
- ▼ Supplied with PicoLog data logging software.
- ▼ Resolution 0.1°C.

TC-08 £199.00

Supplied with serial cable and adaptor. Calibration certificate £25.00. Thermocouple probes available.

TH-03 3 channel Thermistor to PC Converter

- ▼ Connects to serial port - no power supply required.
- ▼ PicoLog data logging software.
- ▼ -55 to 105°C temperature range
- ▼ Resolution 0.01°C.

TH-03 £79.00

Supplied with serial cable and adaptor. Thermistor sensors available.

Call for free demo disk or download our web site: <http://www.picotech.com>
All prices exclusive of VAT.

Broadway House, 149-151 St Neots Rd, Hardwick, Cambridge. CB3 7QJ UK
Tel: (0)1954 211716 Fax: (0)1954 211880
E-mail: post@picotech.co.uk

CIRCLE NO. 116 ON REPLY CARD

Fig. 4. HotBot - Wired's search engine - now indexes more than 50 million pages. Offers easy search control to finds results others miss.



Fig. 5. Essential reading if you use IE3.0 or IE4 beta browsers. Macintosh users are not affected but Windows users should install the final Explorer4 version.



Fig. 6. Java applets cannot open connections to other hosts - or can they? Prove or disprove your browser's Java security in the safety of this test site.



Yes, I would like to subscribe to Electronics World incorporating Wireless World.

- 1 Year UK £32 Europe £46 Rest of world £56
- 2 Years UK £58 **SAVE 10%** Europe £83 **SAVE 10%** Rest of world £101 **SAVE 10%**

Name _____ Job Title _____ Company _____ Address _____

Post Code _____ Telephone _____ Fax _____ Country _____ Internet Address _____

THREE WAYS TO PAY

- 1 I enclose a cheque made payable to Electronics World incorporating Wireless World for £ _____
- 2 Please charge my Mastercard/Access/Misa/Diners Club/American Express (please delete appropriate card) with the sum of £ _____

Card number _____ Expiry Date _____

Signed _____ Date _____

3 Please invoice me/my company. Purchase order number _____

Company VAT registration number _____

Please allow 28 days for delivery of your first issue. Please tick here if you do not wish to receive direct marketing promotions from other companies.

Post in the UK to Electronics World Subscriptions, FREEPOST RCC 2619, PO Box 302, Haywards Heath, RH16 3BR. Telephone 01444 445566
Post from elsewhere to Electronics World Subscriptions, PHQ-D/1700/RH, PO Box 302, Haywards Heath, RH16 3BR, UK. Telephone +44 1444 445566

TRANSFORMERS FOR BALANCED LINES IN HIGH PERFORMANCE AUDIO SYSTEMS



E A SOWTER LTD
PO Box 36 IPSWICH IP1 2EL ENGLAND
Tel: +44(0)1473 252794
Fax: +44(0)1473 236188
E.Mail: sales@sowter.co.uk
Web: http://www.sowter.co.uk

Design and Manufacture of all types of Audio Transformer using Nickel and Grain Oriented cores

Free catalogue
Free technical support service
Popular types from stock

CIRCLE NO. 114 ON REPLY CARD

RF Power Modules from TDC & Mitsubishi

Standard parts stocked, replacement parts for many Yaesu/ Icom transceivers, ideal for linear PA designs.

Part	Frequency	Pwr/Mode	Price (1 off)
M57726	144-148MHz	43W/FM	£43.71
M57729	430-450MHz	30W/FM	£42.00
M57737	144-148MHz	30W/FM	£27.23
M57762	1.24-1.3GHz	18W/SSB	£67.53
M57788M	430-450MHz	40W/FM	£66.99
M67715	144-148MHz	13W/FM	£36.48
M67727	144-148MHz	37W/SSB	£124.59
M67728	430-450MHz	60W/SSB	£99.04
MI407-01	Pin diode up to 800MHz/25W		£1.21

Many other frequencies/ power combinations available, please call with your requirements. Data sheets available for specific items on request.

Call for Amateur/ Education discounts or volume pricing

COMING SOON - Linear power amplifier 'Starter Packs' for 2M & 70cm. **MITSUBISHI ELECTRIC**

TDC also stock Modem, Networking and GPS receiver and antenna products, visit our web site at <http://www.tdc.co.uk> for more information.



Telephone : 01256 332800 Fax : 01256 332810
e-mail : sales@tdc.co.uk

Access/Visa accepted, prices include VAT @ 17.5%, Postage & Packing £5

CIRCLE NO. 115 ON REPLY CARD

'Pico's PC Converters monitor and record temperature and humidity'.

EnviroMon Temperature / Humidity Logger & Alarm System

EnviroMon has many applications in: food processing - storage and distribution, energy management - waste energy, heating and processing, agriculture - monitoring humidity in greenhouses, and in hospitals - accurate monitoring of temperature sensitive items.



- ▼ Monitors up to 30 channels of temperature over a 400 m. distance.
- ▼ -55 to 100°C temperature range (typical accuracy ±0.2°C).
- ▼ Data can be downloaded to PC.

EnviroMon Starter Kit from £393.00

3 temperature Sensors on 5m lead, 3 channel Converter, EnviroMon Logger, cables & fittings. Expandable at any time for around £50 / channel

TC-08 8 channel Thermocouple to PC Converter

Simple to use thermocouple to PC interface.

- ▼ Connects to serial port - no power supply required.
- ▼ Supplied with PicoLog data logging software.
- ▼ Resolution 0.1°C.

TC-08 £199.00

Supplied with serial cable and adaptor. Calibration certificate £25.00. Thermocouple probes available.

TH-03 3 channel Thermistor to PC Converter

- ▼ Connects to serial port - no power supply required.
- ▼ PicoLog data logging software.
- ▼ -55 to 105°C temperature range
- ▼ Resolution 0.01°C.

TH-03 £79.00

Supplied with serial cable and adaptor. Thermistor sensors available.

Call for free demo disk or download our web site: <http://www.picotech.com>
All prices exclusive of VAT.

Broadway House, 149-151 St Neots Rd, Hardwick, Cambridge. CB3 7QJ UK
Tel: (0)1954 211716 Fax: (0)1954 211880
E-mail: post@picotech.co.uk

Pico Technology Limited

CIRCLE NO. 116 ON REPLY CARD

A window on analogue i/o

Colin Attenborough outlines a 12-bit analogue input and output subsystem that runs via the pc's printer port. Colin is also making available his Visual Basic software for controlling the port via Windows.

In the April 1997 edition of *Electronics World*, I showed how to read and write 16-bit digital words through a standard pc printer port, under the control of the Visual Basic language. I used a dynamically-linked library, written in C, to drive the hardware.

This article extends the earlier one to transfer 12-bit analogue data through the printer port - again under Visual Basic control. My software is available on disk; you need only Visual Basic and the disk to control the hardware. For interest, I have added the source code for the necessary dynamically-linked library on the disk, but you do not need a C compiler to use the software.

The circuit of the analogue input/output hardware shown here can be built on its own or added to the digital i/o subsystem previously described. Both clock and data lines use the same pins on the printer port in both cases. Analogue and digital functions available in Visual Basic when the analogue and digital circuitry of the present and previous article are combined are listed in the appendix.

Levels between 0 and 2.5V are accepted by the analogue input; the d-to-a converter output generates between 0V and 4.095V.

Analogue input

The analogue section of the LTC1286 a-to-d

B² Spice & B² Logic

£199

Not Just a Pretty Interface

Software for the professional design engineer

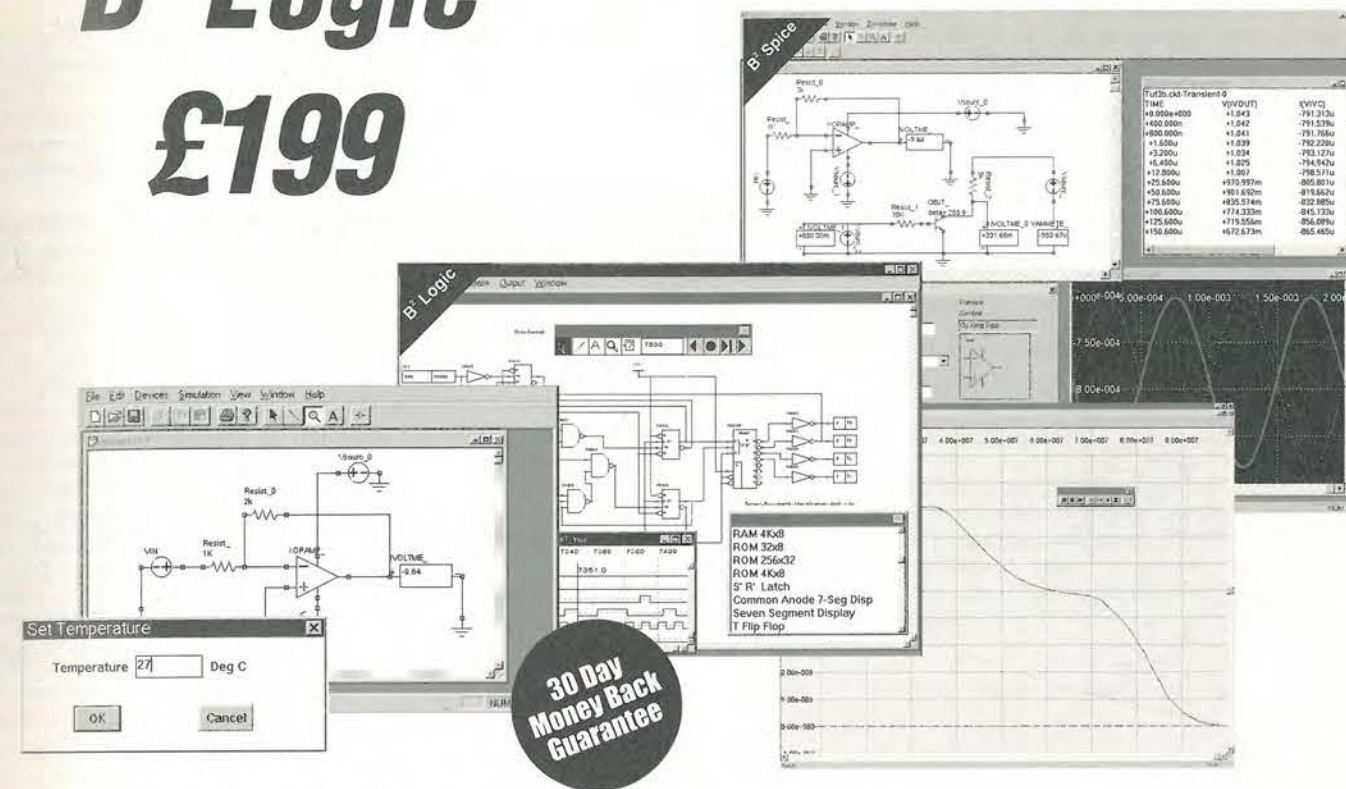

Just some of the features

Fully Integrated and Interactive

Build the circuit on the screen and set up the simulations by choosing options from menus and dialogues. Run the simulation and view your results.

Flexible Visualisation of Results

In B² Spice results can be displayed in graphs, tables or directly in voltmeters and ammeters. Change from typical to worst case analysis and include the effects of temperature on components. You can customise everything, right down to the colour of an individual trace.

Versatility

A plethora of components include resistors, capacitors, inductors, mutual inductors / transformers, controlled sources, bipolar junction transistors, zener diodes, power MOSFETs, JFETs, MOSFETs, voltage regulators, operational amplifiers, opto-couplers, voltage comparators, quartz crystals, IBIS I/O buffers and switching matrix connectors and much more. All devices and model parameters can be edited to suit your needs. Implement hierarchical circuits in your designs quickly and easily.

No Limits

With B² Spice and B² Logic there is no limit on the number of components in the circuit.

Models

There are thousands of models included. The complete Berkeley SPICE model library as well as commercial libraries from manufacturers such as, Motorola, Texas Instruments, Burr-Brown, Maxim, National Semi, APEX Comlinear, AMP, Elantec, Linear Tech, and many more. Included with B² Spice is a full model and symbol editing package so you can create, import and edit custom models.

Cross Probing

Cross probing allows you to display waveform results simply by marking pins, wires and devices on the circuit drawing. Monitor results while the simulation is in progress then plot analogue results on linear or log scales.

Waveform Analysis

Display and compare multiple response curves in a single graph at the same time. B² Spice simulation results can be selectively displayed and analysed graphically and in numerical format as well as exported to other applications. All of B² Spice and B² Logic's display capabilities are completely flexible.

Devices & Stimulus for Simulation

In B² Spice sinusoidal, constant, periodic pulse, exponential, single frequency FM, AM, DC voltage, AC voltage, VCO, Vcc, piecewise linear, exponential, polynomial / arbitrary source, voltage-controlled voltage, voltage-controlled current, current-controlled voltage, current-controlled current, Lossy and ideal transmission lines, MESFET, uniform RC, current and voltage switches are all available.

Graphs

In B² Spice analogue traces may be displayed as raw voltages and current values or further processed using arithmetic expressions, functions and Fast Fourier Transforms. View plot values corresponding to the cursor position on the graph and get data from multiple simulations in one graph. Multiple graphs to be aligned and compared.

Data Analysis

Position detection with mouse for data points. Import and export data to and from other industry standard SPICE programs.

Digital Options.

B² Logic is completely flexible. Set up ROM, RAM and PLA to your own requirements. Shrink a whole circuit to a block and use it as a component in a new design. Run the simulations in real time or step by step. Customise rise and fall time of all components. Results displayed in a logic analyser or table. Select parts from all major logic families. Create your own custom libraries. Create and run pre-programmed simulations.

Professional engineers need software that produces results they can rely on. Anything less is a liability. B² Spice & B² Logic will give you the accurate results you need fast.

The best way to find out if a package is really what you need is to try it, which is what we're giving you the chance to do... risk free for 30 days.

We guarantee you will be 100% satisfied with the results or your money back.

For more information and to order call:

01603 872331

<http://www.paston.co.uk/spice>
email: rd.research@paston.co.uk



RD Research
Research House, Norwich Road, Eastgate, Norwich, NR10 4HA
Postage & packing £4.50. Prices quoted are ex VAT. All trademarks are acknowledged.

Subroutines and functions available to Visual Basic

These subroutines and functions are included in my software, which is available on 3.5in disk for £12.50 fully inclusive by writing to Department VB2, Electronics World Editorial, Quadrant House, The Quadrant, Sutton, Surrey SM2 5AS. You need Visual Basic only to run this software.

With the two combined, you can control the analogue i/o port hardware shown via the graphical user interface shown in the screen shot here.

The address of the printer port is represented by, `_port`. This is usually 378₁₆, but watch the screen as the computer wakes up to check. Function are as follows.

`initialise(int _port)`

Sets the d-to-a converter chip enable, and clears all other lines on the printer port.

`shutdown(int _port)`

Clears all lines on the printer port.

`AdcOn(int _port,int _d)`

Sets the a-to-d converter power line to turn on the a-to-d converter, and takes some dummy readings to allow the supply voltage to settle. Variable `_d` is the delay parameter already mentioned.

`AdcOff(int _port)`

Clears the a-to-d converter power line to turn off the a-to-d converter.

`in_A(int _port,int _d)`

Returns an integer representing the a-to-d converter output. Variable `_d` is the delay parameter.

`in_D(int _port)`

Returns a long representing the state of the digital inputs.

`out_A(int _port, int _data)`

Gives an output of `_data` millivolts from the d-to-a converter.

`out_D(int _port,long _data)`

Sets the digital outputs to `_data`.

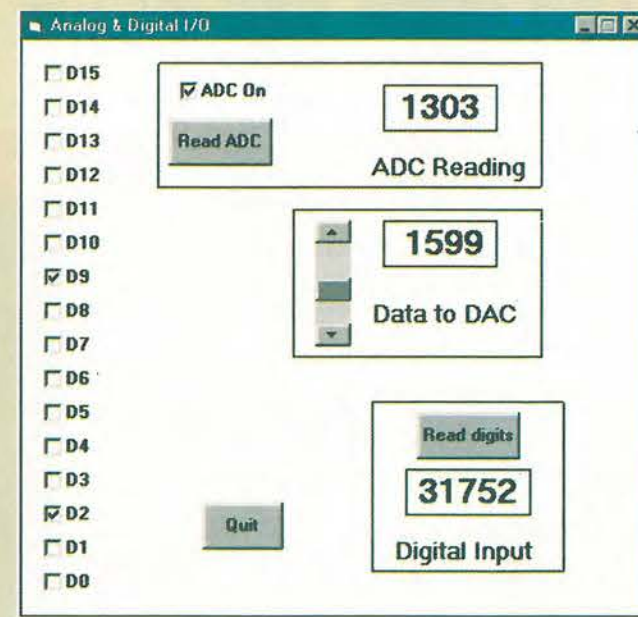

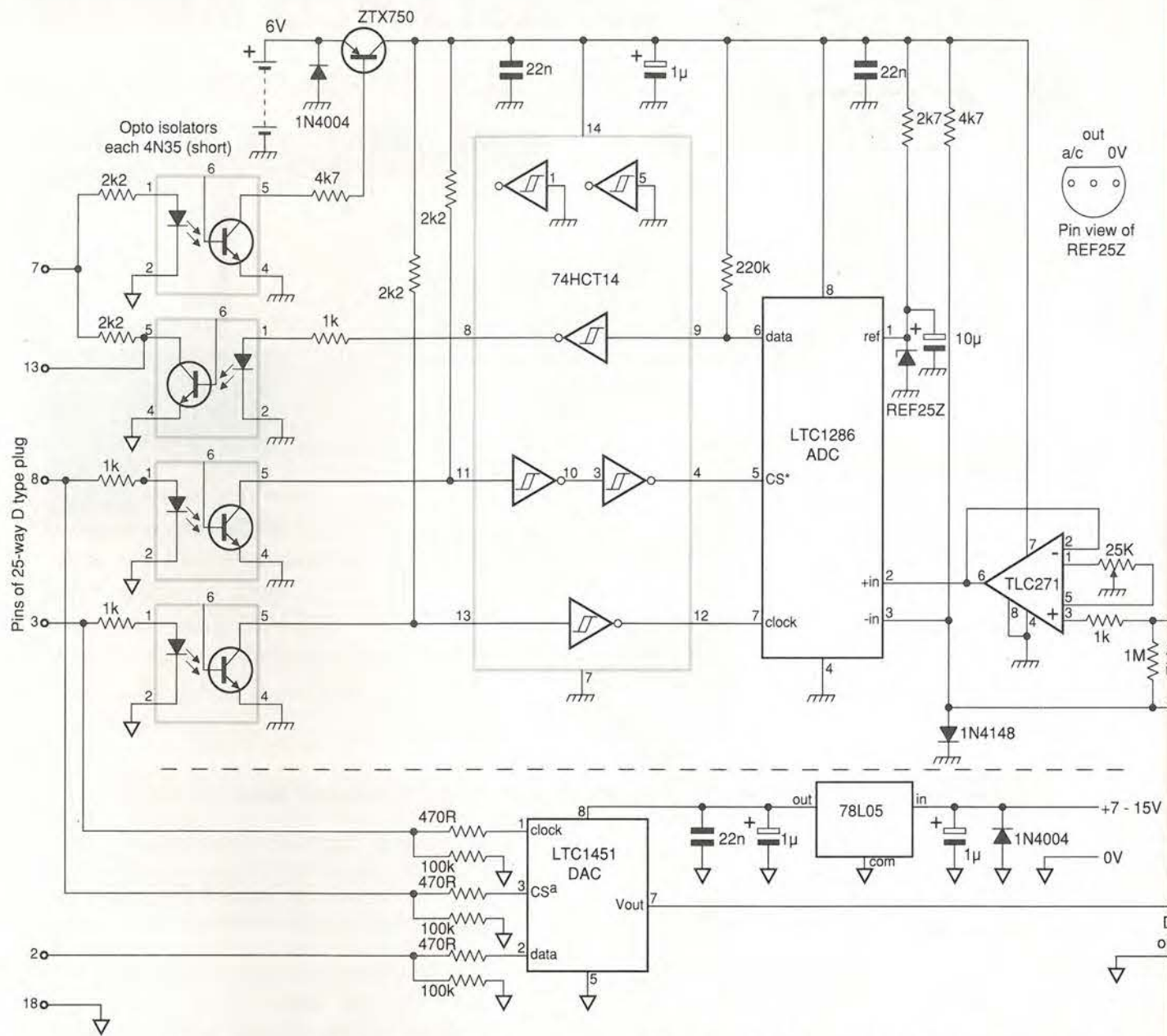

Fig. 1. Designed for battery-powered operation, this 12-bit accuracy analogue-to-digital and digital-to-analogue i/o subsystem is controlled via the pc's printer port. Optoisolators not only provide protection, but also allows floating measurements and removes ground-loop problems.

converter accepts a differential input voltage and a voltage reference; when appropriately clocked, it gives a serial digital output of,

$$code = \frac{4095 \times V_{in}}{V_{ref}}$$

By default, chip enable is at logic 1 to power down the a-to-d converter. To make a conversion, clear chip enable to logic 0 and apply fifteen clock pulses; read data at the rising edge of each clock pulse, most significant bit first, and then set chip enable to logic 1.

Opto isolators convey the chip select, clock and data signals; a fourth opto isolator switches power to the whole analogue input system. Since the system is powered by a battery – of typically four AA cells – power conservation is important.

I've chosen to isolate the analogue input section from the computer via opto isolators;

this allows floating voltage measurements to be taken, and avoids earth loops with their attendant errors.

The a-to-d converter is most accurate when fed from a low source resistance, so a TLC271 op-amp is inserted as an input buffer. This op-amp also has the virtue of buffering the voltage being measured from the capacitive switching input current spikes which occur during conversion.

To allow the op-amp some headroom (shouldn't that be footroom?) I have exploited the differential input of the a-to-d converter, putting the negative input a diode drop above the system 0V line. This means that the op-amp output is always comfortably above its negative supply.

The system needs a supply voltage of between 4.5 and 6V. While the optoisolators specified have a breakdown voltage of 2.5kV,

other factors may limit the voltage that can safely be applied. Layout of whatever pcb or other form of construction is used in the area of the optoisolators is an example. In any case, consider your own safety when there are large voltages across the optoisolators.

Converter setup and accuracy issues

I have deliberately run the optoisolators at low currents to extend battery life. The penalty is that the comparatively high load resistors mean that the rise times at the phototransistor outputs are quite long.

To guarantee correct clocking, I have included a delay parameter in the function which reads the a-to-d converter. This is just a counter for a delay loop; a large value gives a large delay. Start with a large value, of say 2000, read the a-to-d converter with a known input voltage, and reduce the delay as far as possible while reliably getting the same output reading.

The delay does not affect accuracy. With a 100MHz 486 machine, a delay parameter of

250 gave stable results; the conversion time was about 1.5ms. Faster machines will need a larger value for the same a-to-d converter clock pulse width.

The offset adjustment potentiometer should be adjusted so that with no input voltage the output code flickers between 0 and 1.

Input voltage is defined by,

$$V_{in} = \frac{code \times V_{ref}}{4095}$$

If you want to obtain best accuracy from the system, take into account that the reference generated by the REF25Z can be between 2.475 and 2.525V. If you have a sufficiently accurate voltmeter you can measure it and take into account its real value when you use the converter. Alternatively, you can calibrate it against a known voltage with a voltage source more accurate than the REF25Z.

Analogue output

I've used an LTC1451 serial d-to-a converter. Rather like the a-to-d converter, chip enable,

referred to as CS* in circuit diagram, is at logic 1 by default.

To convert a digital data stream – most significant bit first – to an analogue output voltage, clear chip enable to logic 0 and apply twelve clock pulses, with the bits of the data stream valid at the rising edge of the clock pulses, and then set chip enable to logic 1.

The d-to-a converter gives an output of,

$$V_{out} = 2V_{ref} \times \frac{code}{4096}$$

For the nominal reference voltage of 2.048, this simplifies to,

$$V_{out} = code \times 1mV.$$

There is a maximum offset error of ±12mV at room temperature; the nominally 2.048V reference has a maximum error of ±40mV.

I would like to thank Cambridge Consultants Ltd for permission to publish this article.

NOW AVAILABLE RANGER 2 for Windows 95™

The Complete, Integrated Schematic & PCB Layout Package

Windows Ranger 2

- For Windows 95 & NT
- New Hierarchical Circuit
- Split Devices • Gate & Pin Swap
- New Edit Devices in Circuit
- Copper Fill • Power Planes
- Autrouter • Back Annotation

£250

Ranger 2 Outputs:
Full Windows Outputs
Plus - HP-GL
Gerber
NC Drill
AutoCad DXF

Windows Ranger 2 with Spectra SP2

Ranger & Spectra Autorouter provide the most cost effective PCB Design system available. A powerful, intuitive system at an outstanding price!

£500

Windows Ranger 2 Upgrade

Upgrade your existing PCB Package to Windows Ranger 2.

Demo disc available £5.00 (Prices exc VAT/P&P)

£150

Call 01730 260062

Fax 01705 599036 Old Buriton Limeworks, Kiln Lane, Buriton, Petersfield, Hants. GU31 5SJ

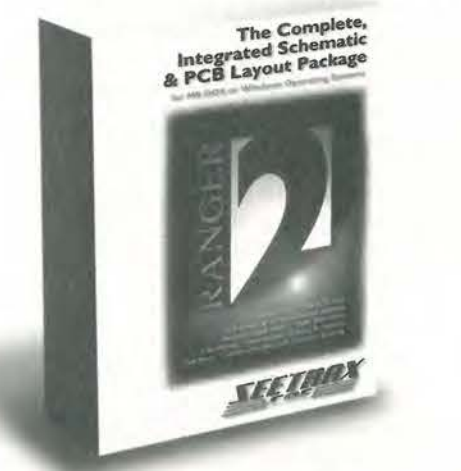

CIRCLE NO. 118 ON REPLY CARD
SEETRA
Advanced Systems & Technology for PCB Manufacture

You may know which capacitor technology to choose for a given task, but do you know why it's the best choice? Having spent thirty years designing, specifying and troubleshooting capacitors, Cyril Bateman shares his expertise.

Understanding capacitors

To my surprise, recent review of my publications library revealed a scarcity of capacitor articles. Perhaps I should have anticipated this since on reflection, many text books and circuit simulators all consider capacitors as ideal, so why delve further. On the other hand, capacitors have also been called 'strange devices', i.e. *unfamiliar*, which this article seeks to remedy.

Thirty years of experience as a capacitor design and applications engineer has convinced me that over-stressed or mis-applied capacitors are involved either directly or indirectly in most circuit failures. All components wear out in time, but mis-applied capacitors can fail extremely quickly. Worse still, before the capacitor ultimately fails, it can directly contribute to failure of semiconductors, masking the prime failure mechanism.

The best way to understand unfamiliar components is to perform measurements on representative samples, then dismantle them to understand their differing constructions. But with capacitors, not all the significant details are immediately apparent.

Capacitor overview

The fundamental definition of capacitance

relates to charge and voltage, measured statically. Descended from the Leyden jar, a capacitor is essentially an energy storage device. Since its stored energy can be charged or discharged extremely quickly, alternative common usage ac definitions have been derived, as discussed in the panel entitled 'Defining capacitors'.

Of these definitions, the most important relates a capacitor's impedance to frequency,

$$|Z| = \sqrt{R_s^2 + (X_{c_s} - X_{l_s})^2} \quad (1)$$

Where,

$$X_{l_s} = 2\pi f L_s \quad (2)$$

and,

$$X_{c_s} = \frac{1}{2\pi f C_s} \quad (3)$$

Throughout this article, the series equivalent expressions are used, denoted as X_{c_s} , R_s etc., unless otherwise stated.

At any frequency, the term $X_{c_s} - X_{l_s}$ can be simplified to jX_s , giving the fundamental vector equation for impedance, $Z = R_s \pm jX_s$.

This vector equation leads to the common usage expressions for impedance magnitude $|Z|$,

$$|Z| = \sqrt{R_s^2 + X_s^2}$$

and phase angle,

$$\theta = \tan^{-1} \frac{X_s}{R_s}$$

This phase angle definition results in the second most important quantity for capacitors – loss factor,

$$\tan \delta = \text{abs} \frac{R_s}{X_s}$$

An ideal capacitor would have a phase angle, hence $\tan \delta$, that remained constant regardless of frequency. Since by definition, eqn 3, a capacitor's reactance, X_{c_s} , is totally dependent on frequency, so also must be the capacitor's series resistance, R_s , known as esr. This is clearly demonstrated by the results measured for a very high quality polystyrene capacitor, **Table 1**.

What is a capacitor ?

Any two conducting surfaces, separated by an insulator, exhibit capacitance. The value of this capacitance increases with surface area and reduces with separation.

The fundamental definition of capacitance assumes this insulator is a vacuum, thus directly relating to the permittivity of free space.

Capacitance=

$$\text{Free space permittivity} \times \frac{\text{Area}}{\text{Separation}}$$

But area and separation alone are insignificant compared to the contribution provided by a change of insulation material. Each insulation material used is rated for dielectric constant, or

'K' value. This represents its permittivity relative to free space.

In practical materials used to make commercial capacitors, this 'K' ranges¹ from 1.00059 for air, 2 to 4 for plastic films, 8 for aluminium, 28 for tantalum electrolytics, and from 6 up to 12000 for differing ceramic formulations.

Given this wide range of dielectric constants, it is natural to loosely categorise all capacitors by the dielectric material used. While in general this is valid, the final capacitor's size and electrical properties also vary according to the construction methods used.

For a given dielectric, thickness – or rather thinness – is all important in determining the capacitance achieved in a given physical size. Usable dielectric thickness is limited by its ability to sustain the required voltage as well as surviving manufacturing methods. Common plastics which can be manufactured in micrometre thicknesses², withstand around 500V dc per micrometre, at room temperature, short term.

Since the dielectric for electrolytic capacitors is 'formed' in situ on the base foil, it doesn't need a minimum thickness to provide handling strength, as do plastic films. Together with certain multilayer and disc ceramic construction techniques, electrolytic dielectric thinness is limited only by the voltage that needs to be sustained.

To minimise the final size, the dielectric together with its conducting surfaces – the electrodes – may be compacted using winding, stacking, folding or layering techniques. These processes lead to supplementary descriptions including wound, stacked and multilayer.

Electrodes formations

The conducting surface for paper or plastic dielectric materials is produced by one of two common techniques. In one of them, an extremely thin, visually transparent coating of metal, generally aluminium, is vapour deposited on to the insulator in a vacuum chamber, resulting naturally in the description metallised capacitor. This method however cannot be used with polystyrene.

When the dielectric itself is not metallised, the alternative and electrically superior method uses thin flexible soft metal foils or discrete metallised plastic foils, as electrodes. These foils are interlaid with the dielectric during assembly.

The surface of ceramic dielectrics is generally made conductive by coating with suitable metal inks. After air drying, these are 'fired' at high temperature.

With aluminium electrolytics, the aluminium base anode foil has the dielectric oxide, i.e. Al_2O_3 , pre-formed electrolytically on its surface prior to assembly. The anode foil acts as one conducting electrode.

This electrolytically formed dielectric's thickness is self regulating, attaining some 14Å for each volt applied in manufacture. At 10V working for example, this represents only

0.02µm dielectric thickness (1µm, or micron, is 0.00394in). The true second electrode is the electrolyte material with which the separating tissue paper is impregnated.

Assuming a polarised capacitor, connection to the electrolyte is made using a second, usually thinner, aluminium foil or cathode. While this cathode is not deliberately formed, it inevitably possesses a much thinner naturally occurring aluminium oxide, electrically equivalent to a few volts. In this way, a pair of back to back capacitors is created. One has the desired capacitance and voltage capability while the other has a much greater capacitance but only a few volts capability, applied in reverse.

With a non-polarised, or bi-polar capacitor, this unformed cathode is replaced by a second deliberately formed anode foil. This results in two capacitors back to back, usually having the same capacitance and voltage capability.

Depending on the desired life-length characteristics, the pre-forming voltage used can range from 1.2 times to more than double the working voltage, trading size and cost against leakage current, and hence endurance.

Properties of capacitors

Every capacitor needs conducting surfaces, or electrodes, which inevitably have some intrinsic resistance. Having a physical cross section and length equates automatically to inductance, called self-inductance. As a result, a capacitor must be represented as a series CLR combination circuit.

This CLR network results in a circuit whose resonant frequency depends on the capacitor's value and construction. At the resonant frequency, the capacitor represents a dc blocking low value resistance, and a dc-blocking but inductive reactance at frequencies above this resonance.

At any frequency, a perfect capacitor, having neither resistance nor inductance, would sustain a voltage in quadrature with the applied current. Analysed on a polar display, voltage would be -90° and current 0° , so the complementary angle delta would be zero. Having no resistive element, this perfect capacitor cannot lose or dissipate energy.

The self-inductance results in a voltage at $+90^\circ$. This subtracts magnitude from the capacitive voltage, increasing the apparent capacitance value which would be measured.

With a near perfect capacitor, the above resistance, appearing in series with the capacitive reactance, degrades this -90° angle, resulting in the complementary angle delta increasing. This change in phase angle represents the resistive element which dissipates energy as heat in the capacitor, **Fig. 1**.

With capacitors, it is usual to refer only to this delta loss angle, which is generally described as $\tan \delta$.

Dielectrics

Unfortunately, all dielectrics other than vacuum contribute their own particular degra-

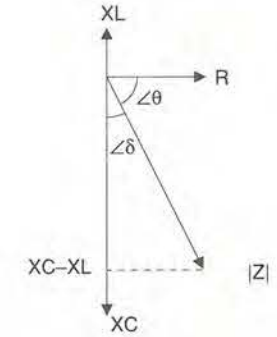

Fig. 1. This simple vector diagram shows the relationship between $\tan \delta$ and $\cos \theta$. Both are essentially equal only with small loss angles. The interaction between the capacitance X_c and inductance X_l vectors is also visible.

dations from this near ideal capacitor. In general the more highly stressed the dielectric, in volts per micron, the greater the degradations.

Since the characteristics of both vacuum and air capacitors depend principally on the particular insulators used to support their assembly, they are excluded from these discussions.

Depending on the symmetry of its molecular structure, each plastic dielectric can be described as having either polar or non-polar characteristics. A symmetrical-molecule plastic, or other non-polar dielectric, has electrical characteristics effectively constant with changing frequency, and exhibits minimal dielectric absorption effects.

If this polymer molecule is not symmetrical, it has a dipole moment resulting in increased dielectric constant. Similarly, ferroelectric ceramic crystal poles and domains can produce extremely high dielectric constants. Such types are known as high-K dielectrics.

Both result in polar characteristics, i.e. a capacitance that reduces and a $\tan \delta$ that increases with frequency. These are functions of the basic materials used – not to be confused with the constructional terms polarised and non-polarised or bi-polar, as applied to electrolytic capacitors.

While manufacturing techniques cannot change a polar dielectric into a non-polar, they can enhance the polar effect. Stressed with dc voltages, polar materials exhibit a reluctance to accept or release their full charge instantaneously – a behaviour called dielectric absorption.

What is dielectric absorption?

If a capacitor is fully charged, to say 10V, for a considerable time, briefly discharged using a short circuit, then left to recover, a voltage is found which develops with time. The ratio of this resultant voltage compared to the initial charge voltage, is described as dielectric absorption.

In past years dielectric absorption was only

Table 1. Clear demonstration of how esr changes significantly with frequency. Measured results of a high quality 10nF polystyrene foil/film capacitor, made using a four terminal Wayne Kerr 6425 precision component analyser at a test voltage of 1V.

Frequency	Capacitance (nF)	Tanδ	'Q'	ESR (Ω)
100Hz	9.9982	0.00010	9000	17.0
1kHz	9.9988	0.00005	20000	0.8
10kHz	9.9986	0.00015	6000	0.26
100kHz	10.0000	0.0005	3000	0.05

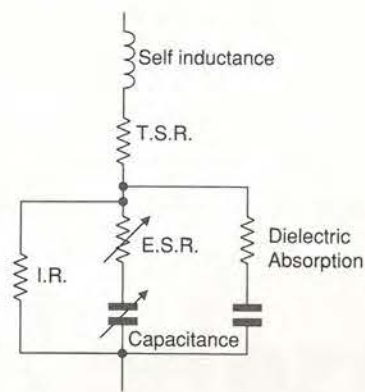

Fig. 2. Full equivalent circuit for a practical capacitor. In practice esr includes the tsr resistance, which is only shown separately to aid explanation.

considered relevant to high voltage capacitors, as a safety hazard. With modern techniques it becomes relevant at very low voltages.

Measured values of dielectric absorption vary with measurement technique, but more importantly with dielectric stress applied, in volts per micron. Typical figures range from 0.05% for polystyrene², 0.25% for polyethylene terephthalate, or PET, to 5% for aluminium.

Some dielectric materials also have a small degree of piezoelectric effect, which can result in a voltage when they are mechanically constrained, whether physically or from temperature changes while rigidly or surface mounted. Some care is needed to differentiate this effect

from that of dielectric absorption.

Both effects are small and are irrelevant for most applications. However when working with sample/hold circuits, charge amplifiers, etc., capacitor choice should account for these effects.

According to manufacturing techniques used, every practical capacitor exhibits some dielectric absorption effect. However polystyrene or polypropylene film/foil and COG NPO dielectric ceramic capacitors, show minimal effects.

With the inclusion of this dielectric absorption mechanism, it is now possible to deduce the equivalent circuit for a practical capacitor, Fig. 2.

How temperature affects capacitors

Ceramic COG NPO type capacitors are restricted to ±30ppm/°C change of capacitance with temperature and are the most stable available. With the exception of these, all dielectrics show easily measured larger capacitance changes over their temperature range.

General-purpose ceramic capacitor dielectrics are categorised under the EIA classification scheme. The popular X7R material is thus restricted to a box envelope allowing ±15% change in capacitance over its working temperatures. However the exact profile within this envelope, differs with manufacturer.

Change in temperature also results in a change of measured tanδ for most common dielectric materials. Non-polar dielectrics show very small changes, but with a polar dielectric, the maker's data should be consulted.

The behaviour of plastic-film capacitors however tends to be consistent according to the materials used and less dependent on specific manufacturer.

Voltage effects

Many polar dielectrics have a capacitance which changes with applied ac or dc voltage. With voltage, capacitance tends to increase above that measured at 1V then declines. Since this behaviour depends on the precise dielectric chosen and manufacturing technique, makers data should be consulted.

Frequency effects

As shown in published data, almost all capacitors exhibit a frequency-dependent capacitance change. Less well known, the dielectric strength or voltage withstand of film dielectrics, can reduce² with increasing frequency. For many applications this is not important since the power or current rating constraints which should be applied, dominate.

With pulse waveforms having large peak-to-mean ratios, power constraints no longer dominate, so it is essential to consult makers' data when choosing a capacitor for pulse duty

More significant for general applications, every capacitor regardless of dielectric has frequency dependent tanδ losses, which increase with frequency.

Power limitations

Having mentioned power ratings, surely since current and voltage are in quadrature, no power is dissipated in a capacitor?

I mentioned that a near ideal capacitor has

conducting surfaces with a finite resistance. These electrodes must connect to the outside world using one of a variety of means, inevitably adding resistance. The sum of these metallic resistances, true series resistance, or tsr, is a very low value fixed resistance. For convenience, since it cannot be otherwise separately measured, it is sometimes viewed as being the minimum impedance, seen at resonance, on a conventional impedance and frequency plot, Fig. 3.

However other, usually much larger, loss

resistances are found in practical capacitors. Every capacitor exhibits a leakage current, which is voltage and temperature dependent. A rule of thumb based on the Arrhenius law, is to assume this current doubles for each 10°C increase in temperature. Obviously this current can be represented by a high value insulation resistance in parallel with the dielectric. More conveniently, following the parallel-to-series conversion rules, it equates to a very small fixed value series loss resistance.

With most capacitors, the dielectric's tanδ,

frequency, voltage and temperature related losses dominate. These are also expressed as series resistance.

The sum of all these resistances, at any one frequency, is called the equivalent series resistance or esr. As can readily be seen, esr is frequency, voltage and temperature dependent, so when quoted in makers' data, it only applies to the particular conditions quoted.

To aid understanding, it is perhaps easier to consider esr as a combination of the above leakage resistance and tsr, together with a

Defining capacitors

The fundamental definition¹ of capacitance C in farads is the ratio of charge acquired in coulombs Q to the applied voltage V.

$$C = Q/V$$

For two flat conductive plates separated in vacuum, the fundamental capacitance formula becomes,

$$\text{Capacitance} = \text{Free space permittivity} \times \frac{\text{Area}}{\text{Separation}}$$

where free-space permittivity, ε₀, is 8.854188×10⁻¹²F/m

All other insulating materials have a dielectric constant, K, relative to this free space value,

$$\begin{aligned} \text{Capacitance} &= K \times \text{Free space permittivity} \times \frac{\text{Area}}{\text{Separation}} \quad \text{F/m} \\ &= 0.0885 \times K \times \frac{A}{S} \quad \text{pF/cm} \end{aligned}$$

In essence any two conducting surfaces, separated by an insulator, exhibit capacitance, with a value which increases with surface area and reduces with separation. Subjected to an ac voltage, an ideal capacitor resists or impedes the passage of current according to its reactance value,

$$X_c = \frac{1}{2\pi FC}$$

developing a voltage lagging the current by 90°.

In practice, every capacitor incorporates a resistive component. Expressed using the conventional series notation, this resistance further resists or impedes the passage of current,

$$Z = \sqrt{R^2 + X_c^2}$$

Each practical capacitor also incorporates an inductive element, which incorporated in the above provides the full equation for impedance,

$$Z = \sqrt{R^2 + (X_c - X_l)^2}$$

where $X_l = 2\pi FL$.

At any given frequency, the term $X_c - X_l$ can be simplified into its series equivalent, jX_s , giving the vector equation, $Z = R \pm jX_s$. This results in the magnitude/angle expressions,

$$|Z| = \sqrt{R^2 + X_s^2}$$

$$\angle \theta = \tan^{-1} \frac{X_s}{R}$$

In the above expressions the R term represents the equivalent series resistance of the capacitor, while the X term represents the series reactive component. When viewed as a vector diagram, a

polar plot, or on a Smith chart, this X term has a negative value for capacitors, Fig. 1.

The commonly used expressions,

$$\tan \delta = \text{abs} \frac{R_s}{X_s} \quad \text{and} \quad C = \frac{-1}{2\pi FX_s}$$

also apply.

Series or parallel?

The impedance vector of a practical capacitor at any one given frequency can be represented using an equivalent circuit of the device with a resistor. The resistor, used to degrade the phase angle to that measured, can be either a high value in parallel with the device, or a low value in series with the device, leading to the term 'equivalent series resistance' or esr.

While the parallel equivalent values have use for certain calculations, the series equivalent values are more commonly used. Throughout this article, the series equivalents are used unless otherwise stated.

Take this practical example. An impedance vector, magnitude 100Ω and phase angle -84.3° at 1kHz, represents a capacitor having a tanδ of 0.1 and a Q of 10. This vector would result from a series combination of 9.95Ω resistive and -99.5Ω reactive, i.e. a 1.6μF capacitor or a parallel combination of 1005Ω and 1.584μF. A difference in equivalent capacitance value of 10%. The equivalent series resistance would be 9.95Ω.

Parallel impedances

Certain measuring instruments or mathematical calculations are more suited to the equivalent parallel expression, which can easily be converted to or from the series values.

$$R_p = \frac{R_s^2 + X_s^2}{R_s} \quad \text{and} \quad X_p = \frac{R_s^2 + X_s^2}{X_s}$$

Sometimes the measured results are needed as admittance rather than impedance; conversion from the parallel impedance expression is simple,

$$Y = \frac{1}{R_p \pm jX_p} = G_p \pm jB_p$$

$$G_p = \frac{R_s}{R_s^2 + X_s^2} \quad \text{and} \quad B_p = \frac{X_s}{R_s^2 + X_s^2}$$

The conversion from parallel impedance back to series impedance format, following,

$$R_s = \frac{R_p \times X_p^2}{R_p^2 + X_p^2} \quad \text{and} \quad X_s = \frac{R_p^2 \times X_p}{R_p^2 + X_p^2}$$

is equally simple.

Fig. 3. This PSpice simulation shows the affect of 1nH inductance with 0.01Ω esr or tsr on four near ideal capacitors, 100μF through 0.1μF. The 1μF capacitor highlighted also shows comparison of increased esr of 0.1Ω and reduced esr of 0.001Ω, giving dramatically changed plot shape, with small values of esr.

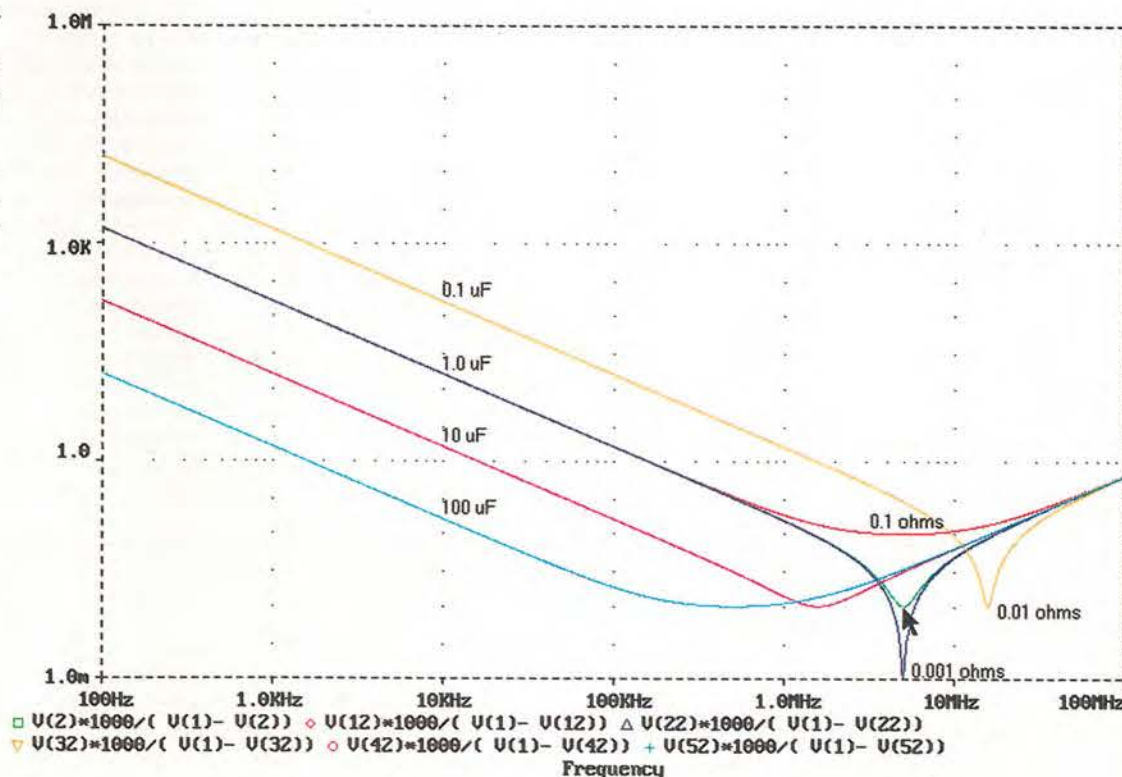

number of variable contributions dependent on frequency, voltage or temperature. This esr, together with the alternating current passing through the capacitor, can be used to calculate the power dissipated in the capacitor.

When the capacitor is subjected to a sine wave, simple calculations suffice. Given a complex waveform, the only method^{3,4} that ensures accurate results is to use Fourier transforms to characterise the waveform into its discrete frequency components.

Only when a capacitor is measured at its final working frequency, temperature and voltage can its esr be derived directly from bridge measurements of $\tan\delta$ and capacitance. But in most applications it is not practicable to make bridge measurement under such conditions. Consequently esr must be estimated taking account of each variable in turn.

I have stressed that esr is frequency dependent, but does it really change by a significant amount, or am I simply being pedantic?

Consider the esr of a high-quality 10nF polystyrene foil/film capacitor. I selected such a device as one of the standard capacitors when building my capacitance bridge. All measurements were taken using a four terminal Wayne Kerr 6425 precision component analyser, with a test voltage set to 1V, Table 1.

These results show clearly how esr values do change significantly with frequency, for this high quality capacitor. Many writers on this topic have confused these esr and tsr terms. Obviously they differ substantially, except at that frequency when the capacitor is self resonant.

Since correct understanding of esr is essential to avoid over-stressing capacitors, I make no apology for labouring the point.

Implications of voltage ratings

Many years ago, when impregnated metallised paper capacitors were the standard workhorse, it was considered that a capacitor rated for 400V dc or above could be used on 250V ac mains. Since these capacitors were impregnated, this was just about feasible. Unfortunately this premise tends to continue even today.

When the then new unimpregnated met-

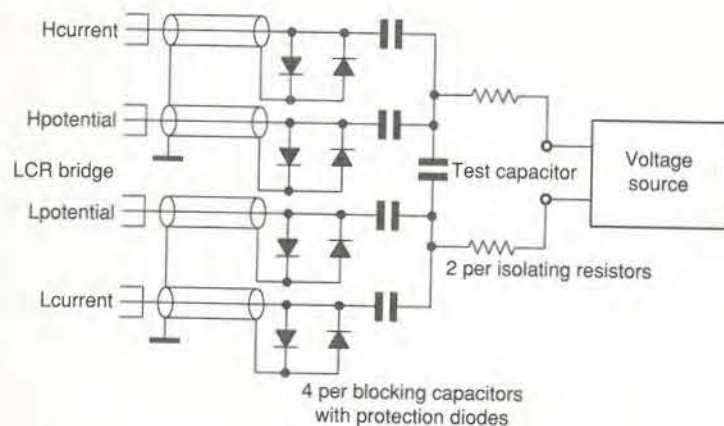

Fig. 4. This simple dc blocking buffer circuit allows measurement of capacitance change with applied dc volts. The isolating resistors should each present at least ten times greater impedance than the test capacitor. Likewise, the dc blocking capacitors must withstand the dc test voltage and have at least ten times the test capacitor's capacitance.

allised PET capacitors became commonly available thirty years ago, 400V dc parts were used for many of these 250V ac mains requirements. Result – misery. If you were lucky, the end terminations eroded, disconnecting the capacitor. If you were unlucky, the capacitor caught fire.

Even today, I have vivid recollections of this unhappy time, when my task was to withdraw from all 250V ac applications and re-rate the capacitors to 160V ac, on behalf of my employer, for this particular construction.

Why should this problem arise?

Given an impregnated or otherwise solid, void free, capacitor construction, 250V ac and above causes no insuperable problems. However with non-impregnated non-solid constructions, air voids occur within the capacitor.

According to Paschens curve of ionisation, an air-filled void having optimum size and air pressure can exhibit ionisation inception at voltages as low as 185V ac. This is why 160V ac was adopted in the previously-mentioned application to provide a safety margin.

Once triggered, the ionisation current is self sustaining at lower voltages – in fact almost to zero volts. Thus once triggered, the resulting

discharge continues for at least 50% of the periodic waveform.

This ionisation discharge is damaging to almost all dielectric materials, resulting ultimately in a short circuited capacitor.

From these experiences, international and national safety rules for class X capacitors, used across the 250V ac domestic mains, were developed. Two main capacitor styles emerged. These were a much updated resin impregnated metallised paper capacitor⁵ and the two-in-series metallised polypropylene style, which worked since its two series capacitor elements shared the applied voltage.

Manufacturing measurements

National and international capacitor approvals require manufacturers' measurements to be 'true' values, i.e. traceable to nationally held standards. In general, this means that measurement equipment must have an inherent accuracy ten times better than any claimed component parameters. Measured values must be 'inset' sufficient to eliminate all known measuring equipment errors.

With low-loss or close-tolerance capacitors, these requirements are not easily attained. A test frequency of 1kHz is standard for capacitors of value greater than 1nF except for electrolytic types, which are generally tested at 100Hz. Resulting from their high impedance at 1kHz, capacitors equal to or less than 1nF are tested at 1MHz. In general, test voltages of 1V ac or lower are used.

Experimenters' measurements

Commercially available capacitance test equipment can supply a DC polarising voltage to the component, but is generally restricted to a maximum of 20V dc.

However an adapter permitting much higher voltages can be simply made. Hewlett Packard application note 346 – a Guideline for Designing External DC Bias Circuits⁶ – provides details of adapters for their ranges of precision meters. However these principles can easily be extended to any equipment

larger capacitors, four-terminal connections and switching of the low-impedance current paths is advised.

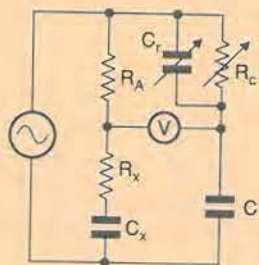

Wheatstone bridge

A capacitance bridge⁷ that can be used at audio frequencies to directly measure capacitance and esr is shown. It is easily built using standard resistor and capacitor decade boxes together with one known high-quality standard capacitor.

With range switching resistors to replace R_A and three switchable standard capacitors, this circuit has been used to measure both capacitance and esr from a few picofarads to a hundred thousand microfarads. For best accuracy with the

Power stress circuit

When designing switching supplies, much benefit derives from measuring a capacitor at its final working voltage and frequency. While low power measurements using a bridge are possible, other techniques are essential for higher powers or voltages.

These power or voltage limitations result because taking current in quadrature with voltage stresses any power amplifier. The amplifier's power dissipation increases rapidly when driving a capacitive load, leading to instability or failure.

If this capacitive load is resonated using a suitable inductor, the power amplifier is presented with a zero phase load. The inductor provides either the voltage needed to the capacitor, or the current. Since it also needs to supply only voltage or current and not both, amplifier power dissipation can be low, Fig. 5.

Using a series-resonant circuit, the amplifier supplies the required through current but at a much reduced voltage. With a parallel resonant circuit, the amplifier supplies the

required voltage at a much reduced current. The inductor's stored energy supplies the missing voltage or current drive required by the capacitor. The amplifier only supplies the power needed to replace that lost due to capacitor dissipation, inductor resistive losses and the protection resistor.

Using a stable air cored inductor with a Q of ten or better, and a 100W mosfet audio power amplifier, capacitor voltages of 250V can be easily attained using the series circuit. An air cored inductance provides the stability needed for meaningful calculations.

Conversely the parallel configuration easily provides 5A. The schematic circuit suggests using a series resistor to protect the amplifier in the event of capacitor failure. Much higher levels are possible if this resistor value is reduced.

Capacitance change with frequency, voltage or current can be calculated from the circuit's change in resonant frequency, the voltage drop and through current measurements of the test capacitor.

which might need to be used, Fig. 4.

Commercially available capacitance testers can often measure using more than 1V ac test voltage, but they rarely extend above 20V ac. Higher test voltages are possible using Wheatstone bridge methods but care is needed not to overload either the test source or the bridge measurement arms – especially with increasing frequency.

A low accuracy alternative method which can measure to very high voltages and frequencies requires use of a power amplifier together with suitable high 'Q' inductors. Depending on whether higher voltage or greater current than can be sourced by the amplifier is needed, these inductors are used to either series or parallel resonate with the capacitor. Using these techniques, satisfactory measurements to 500V ac and several amps at frequencies to 1MHz have been performed, Fig. 5.

Capacitor life

Qualification testing requires capacitors to survive continuous operation at maximum ratings and maximum temperature for typically 1000 hours. In some instances the capacitors are required to be stressed in excess of claimed levels, or for much longer times. To understand the implied life-test claims, you need to read the specification.

Compared to actual end use 1000 – and even 10000 – hours endurance is extremely short. But components in end use are not generally continuously stressed, certainly not to their maximum capability and temperature. Arrhenius law suggests that insulation resistances halve, alternately leakage currents double, for each 10°C increase in temperature. Consequently 1000 hours at 125°C can represent a useful life⁴ under normal end use conditions, of 10 to 20 years – even assuming maximum applied voltage.

A secondary benefit results from reduced voltage. All capacitors, including electrolytics, exhibit prolonged life with reduction in operating voltage, even to zero dc, provided any applied ac does not otherwise contravene the capacitor specifications.

One common mis-statement – that electrolytics exhibit no capacitance with zero or reverse bias – is completely unfounded. The dielectric film is chemically robust and cannot in the short term be changed. Long term, assuming reverse voltage is within the permitted levels, leakage current increase can result in parametric failure.⁴

However if an electrolytic which has been operated for some time at reduced voltage, is then subjected to increased voltage, a temporary increase in leakage current results. The capacitor may then fail to meet its specification. Since the converse also applies,

any capacitor subject to excess temperature, voltage or current or mechanical stress, will fail quite quickly.

One special aspect which certainly causes electrolytic failure, is unwitting excessive repetitive reverse bias. This can arise when a polarised capacitor is used to couple the drive waveform into a switching transistor base and at the same time block dc. This mis-use is especially common. I have personally experienced this failure mechanism many times, in both television and satellite receivers.

With switching power supplies, an early indication of an electrolytic being reverse biased is increased transformer noise and notable temperature increases. However with television line and frame timebase generators being less audible, the first indication can be either reduced drive amplitude or semiconductor failure.

Such abused capacitors usually show visible signs of overheating or electrolyte leakage, measurable loss of capacitance and increased esr and reverse voltage withstand. I hope to delve further into this topic in a subsequent article which explores and measures various capacitor constructions. ■

References

1. Reference Data for Radio Engineers, pub Newnes.
2. Capacitors for electronic equipment, 1995, Wilhelm Westermann KG.
3. Bateman, C, 'Power dissipation in capacitors,' EW&WW, April 1995.
4. Data Handbook Electrolytic Capacitors, 1994, Philips Components.
5. Safety requirements for EMI suppression capacitors, <http://www.rifa.se>
6. A guideline for designing external dc bias circuits, Hewlett Packard Application Note No 346.
7. Bateman, C, 'Looking into impedance,' Electronics World, August 1997.

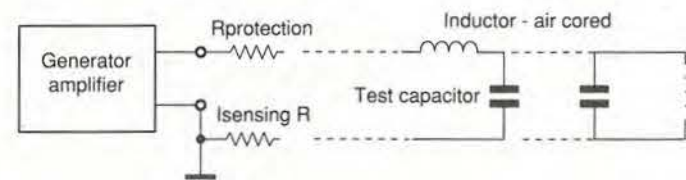

Fig. 5. Taking advantage of inductor Q to produce high test voltages on the capacitor while maintaining the amplifier load near unity power factor. Variations on this circuit enable much investigation into capacitor behaviour using only minimal equipment.

IF HELICAL BPF FILTERS (7H series)

for Set-top Box/Video Sender/WLAN/WLL/CDMA/REPEATER/MCA...
640M/ 612M/ 480M/ 460M/ 410M/ 350M/ 325M/ 240M/ 140M/ 135M/ 110M/ 89M/.....
YOU MAY SPECIFY ANY OF IF-FREQUENCY & BANDWIDTH (3M-35MHz).

Table with columns: TEMWELL BRAND, Fo (MHz), Tuning Range, I/F (MHz), -3dB BW (MHz), Fo-(J)M (MHz), Fo+(J)M (MHz), Group Delay. Lists various filter models and their specifications.

**** RF SECURITY 315-320M/418M/433.9M/447M ****
**** SPECIAL PRICE : @US\$1.40/PC FOR 5K PCS / 7H2 ****
Table listing RF security filter specifications.

**** RF FRONTEND 0.8-1G BPF FILTERS(7H2/3) ****
Table listing RF frontend filter specifications.

SIZE:7H2:14.9 X 7.4 X 13.0mm, 7H3 :22.4 X 7.4 X 13.0mm
We designed over 250 specifications from 55M-1600M, You may select any Fo & BW, Full set of catalog suggest to you, please FAX us today.

Manufacturer : MADE IN TAIWAN
TEMWELL CORPORATION

6F, No.2, SEC.2, MIN SHENG E., RD., TAIPEI, TAIWAN
FAX:886-2-5515250 / 5652287, TEL:886-2-5652500 (7L)
E-mail: temwell@ms12.hinet.net (C:\A:\NFALLAD3.DOC)

CIRCLE NO. 119 ON REPLY CARD

COLOMOR (ELECTRONICS) LTD

170 Goldhawk Road, London W12 8HJ

Tel: 0181 743 0899 Fax: 0181 749 3934

Email: giacomelli@colomor.demon.co.uk

★ CELEBRATING 30 YEARS 1967-1997 ★

Table listing electronic components and their prices, including diodes, capacitors, and resistors.

ALSO AVAILABLE - VALVES:

Table listing vacuum tube valves and their prices.

VALVES WANTED - NEW AND BOXED:

Table listing vacuum tube valves wanted for purchase.

Post and packing:

Orders up to £3 @ £1.95; £5 @ £2.25; £15 @ £2.50; £20 @ £3.50; over 2kg at cost.
VAT included in all prices. Please ring for availability and price

CIRCLE NO. 120 ON REPLY CARD

Halcyon Electronics
Off-Air Frequency Products



We manufacture a range of Off-Air Frequency products including frequency standards, sources and disciplined standards including GPS, Customised units also available

Precision Frequency Source

1kHz to 16MHz sinewave output, 0.0001Hz resolution, Easily settable via decade switches, VCXO backup as standard

Off-Air Frequency Standard

1MHz, 5MHz and 10MHz, outputs, Options include Sinewave, Signal inhibit and Audio Warning

CIRCLE NO. 121 ON REPLY CARD

We are well known for our quality new and used test equipment. Our list is extensive, ranging through most disciplines. Call for details

CIRCLE NO. 122 ON REPLY CARD

Halcyon Electronics

423 Kingston Road, Wimbledon Chase, London SW20 8JR
Phone: 0181 542 6383 Fax: 0181 542 0340

CIRCLE NO. 123 ON REPLY CARD

Never mind the quality - feel the bandwidth

As MPEG video and audio compression becomes increasingly popular, there are signs that the quality is suffering. Here John Watkinson explains why compression artifacts occur and - more importantly - what can be done to reduce them.

John Watkinson, FAES, B.Sc., M.Sc.

In audio/visual program material, the advantages of compression are many - hence its popularity. Compressed material requires less bandwidth which is ideal for broadcasting, where the radio spectrum is under increasing pressure from other mobile services.

Compression also allows the cost of storage or recording to be reduced, although as recording economics improve year on year this may be a transient advantage. Compression principles Figure 1a) shows that in all real digital program material the bit rate is the product of the sampling rate and the word length. In practice the overall bit rate is made up of a varying mixture of unpredictable or novel material, known as entropy, and the remainder which could be deduced from first principles, known as redundancy.

reach an entropy peak together, consequently a transport stream can be divided into a number of varying bit rate channels. Provided that the overall bit rate remains constant, individual channels can demand more bandwidth when difficult material is encountered on the assumption that other channels are probably handling easier material at that time.

In the DVD - digital video disk, also known as digital versatile disk - a variable bit rate is supported in a single program stream simply by changing the rate of disk accesses. Unfortunately the ideal coder of Fig. 1 is infinitely complex and has an infinite processing delay. Practical coders have to constrain both. When either of these constraints are applied, the bit rate has to go up to maintain quality, as Fig. 1c) shows. Figure 2 shows that for constant quality the bit rate will reduce as the latency increases.

Video compression In MPEG-2, the temporal compression is obtained by sending motion compensated difference pictures, and further spatial compression is obtained by transform coding the differences. Differential coding simply subtracts the previous picture from the current picture and sends the difference. When there is motion differences increase. This is handled by measuring the motion between pictures on a 16-by-16 pixel block, or macroblock, basis

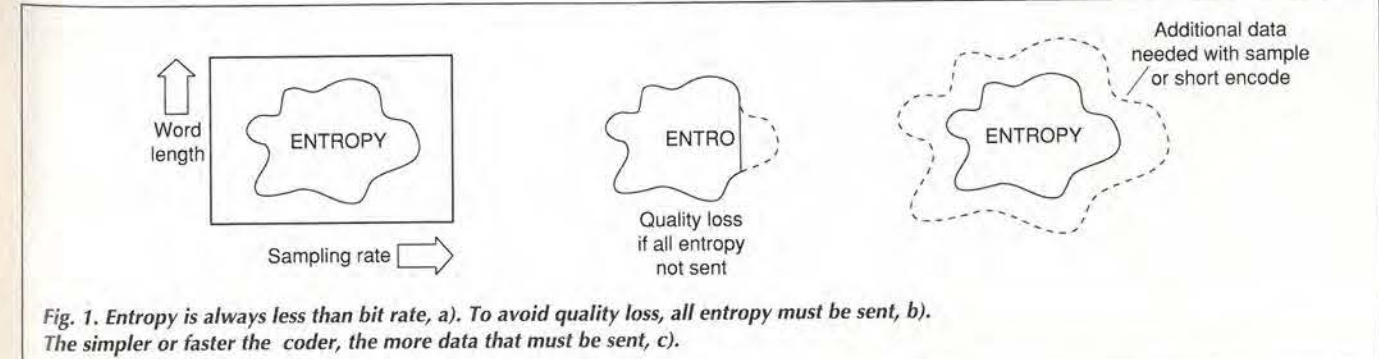

Fig. 1. Entropy is always less than bit rate, a). To avoid quality loss, all entropy must be sent, b). The simpler or faster the coder, the more data that must be sent, c).

and transmitting a vector for each block. The decoder and the encoder both shift the previous picture using the vectors and only the difference between the shifted previous picture and the current picture need be sent.

Pure differential coding fails if there is a transmission error because that error propagates indefinitely. It also makes it hard for the viewer to change channel! In practice periodic whole pictures have to be sent to prevent error propagation and to create decoder entry points. These are known as intra-coded, or I,

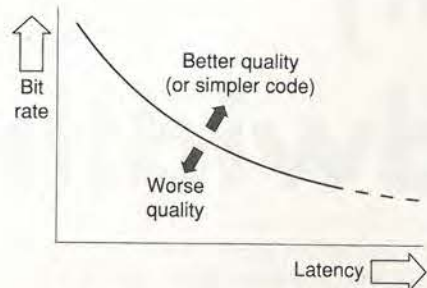

Fig. 2. Shorter latency needs a higher bit rate.

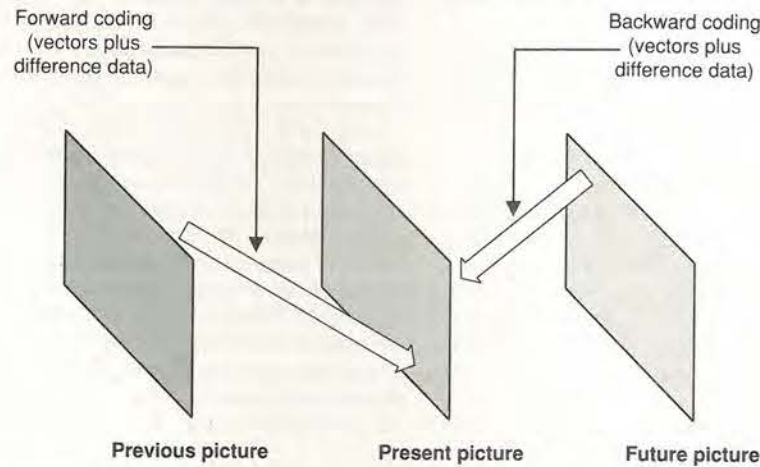

Fig. 3. Bidirectional coding uses information from both past and future picture frames.

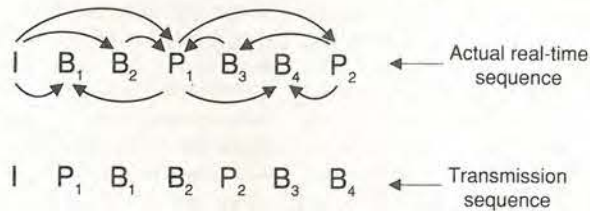

Fig. 4. Bidirectional coding requires pictures to be transmitted out of sequence.

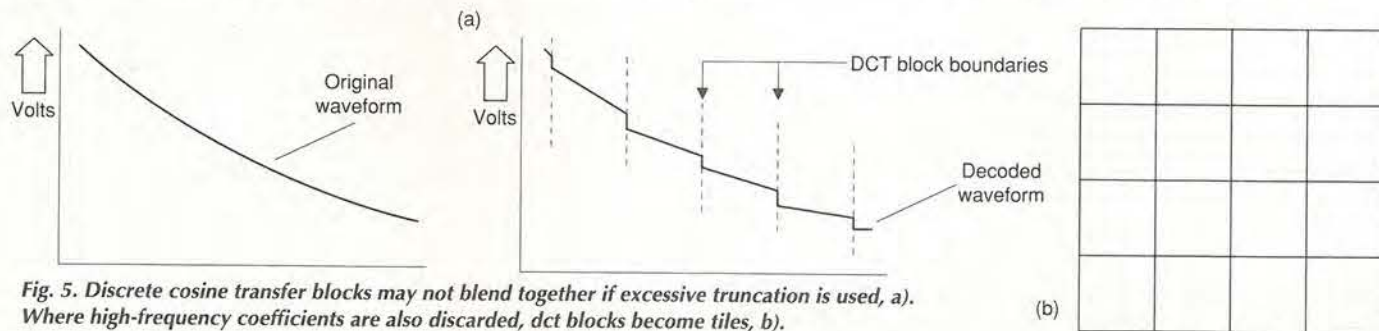

Fig. 5. Discrete cosine transfer blocks may not blend together if excessive truncation is used, a). Where high-frequency coefficients are also discarded, dct blocks become tiles, b).

pictures because they make no reference to any other picture and are only spatially compressed. In between these I pictures differential coding is used.

Moving objects cause problems in differential coding because they reveal background at their trailing edge which is previously unknown.

This is overcome by using information from future pictures. Figure 3 shows that in bidirectional coding a picture can be decoded using information from pictures before or after. The decoder does not need a crystal ball to obtain the future pictures: instead, pictures are sent out of sequence.

Figure 4 shows that after an I picture, a future picture is differentially coded in the forward direction only. This future P (predicted) picture is sent immediately and stored in the decoder.

Pictures between the I picture and the P picture can now be sent these B (bidirectional) pictures can be created by forward or backward motion compensated differences on an individual macroblock basis.

The pictures and difference pictures are spa-

tially compressed. The process begins by performing a dct, or discrete cosine transform, which expresses an 8-by-8 pixel block as a set of 64 coefficients. In typical video material, many of the coefficients will have zero or negligible values so that only the significant ones need to be transmitted.

Compression artifacts

Compressors are generally iterative and are driven by a bit-budget measurement. If the output bit rate is too high for the channel the dct coefficients will have to be expressed in fewer bits. In the case of large value coefficients, when low order bits are lost they become less accurate. In the case of small value coefficients, they may be truncated to zero.

This has a number of side effects. Coarse quantising of large value coefficients means that after the inverse dct at the decoder the eight-by-eight pixel block may have considerable errors in the sample values.

While these are not necessarily visible in themselves, the errors in adjacent blocks will mean that there is a discontinuity in the block boundaries so that the blocks become visible as shown in Fig. 5a). If high frequency coefficients have been truncated to zero the block will lack detail and resemble a tile as in 5b).

This effect occurs in both the luminance and colour difference paths. In luminance the effect is called contouring whereas in colour the effect is called posterising, where gradual colour changes have been replaced by a limited colour set, as might be available in a box of poster paints. In MPEG the colour posterising can be quite obvious because the chroma blocks are the size of a macroblock and have four times the screen area.

Effects of truncating hf coefficients

Where high-frequency coefficients have been truncated to zero, the effect is to introduce ringing on edges. This is because an edge contains high frequencies and removing them is the equivalent of a sub-optimal low pass filter, hence the ringing. This is particularly noticeable on graphics and captions, less so on natural subjects.

When the prediction of the temporal coding fails, the data in the difference pictures will necessarily increase and this will force the compressor to quantise more heavily, raising the artifact level. This is particularly noticeable on B pictures since they are generally allocated only 10% of the data rate.

Temporally difficult material, such as when frequent cuts are made, may overload an encoder. Cuts remove temporal redundancy and defeat bidirectional coding. Following a cut, several pictures may contain serious blocking artifacts.

The real MPEG killer material is video from a press conference where flashguns are firing. Each flash drives up every single pixel value for one picture, and then in the next picture the values come back to normal. This causes temporal chaos and most MPEG coders substitute a picture of the designer's bathroom wall under these conditions.

Pre-processing controls artifacts

The level of artifacts can be controlled by pre-processing. There are three levels at which a pre-processor can operate,

- By removing noise from the source material.
- By removing entropy from the source material.
- By aligning the I pictures in the coder output with the temporal entropy of the source.

Noise in a source pixel block creates more coefficients than a noise free source would.

Thus all coefficients have to be truncated more aggressively to carry them, raising artifact level. Noise also increases data in difference pictures. Hence noise reduction will lower artifact levels by reducing spurious coefficients and reducing picture difference data.

If, after other steps, the artifact level is still too high, then the only approach is to restrict the entropy entering the coder. This is done by down-sampling the source images either spatially, so they contain less pixels, or temporally, so there are fewer pictures per unit time, or both.

In source material from telecine, the use of 2:2 and 3:2 pull-down creates what could be called false entropy, because in 2:2 frames are interlaced to make fields, giving a false doubling of picture rate.

The ratio 3:2 gets its name because 24Hz film frames are alternately converted to two and three fields to give a 60Hz output. One in five fields is redundant. Prior to MPEG coding telecine material has to have redundant fields discarded and remaining field pairs are deinterlaced to obtain the original frames.

The largest usage of data in MPEG is the I picture. This is because it does not use any previous information from the source.

Consequently it makes no difference if the source I picture is radically different from the ones which went before. In contrast both P and B pictures will require significantly more difference data if there is a cut.

It follows that a significant reduction in artifacts can be obtained if I pictures are temporally aligned with source cuts. The only drawback of this approach is that to do it in real time a great deal of memory is needed to pipeline a stack of frames so that picture type decisions can be taken.

The alternative is to use a time coded source recording and use a two-pass encoding process. On the first pass the cuts are detected and used to design a picture type structure which is stored, and on the second pass the structure is implemented.

John is an independent consultant in digital audio, video and data technology and is the author of fifteen books on the subject, including Compression in Video and Audio. He is a Chartered Information Systems Practitioner, a Fellow of the Audio Engineering Society.

The Low Cost Controller That's Easy to Use

Features

The K-307 Module provides the features required for most embedded applications

- Analogue** • 4 Channels in 1 Channel out
- Digital** • 36 Digital in or out & Timers
- Serial** • RS-232 or RS-485 plus I2C
- Display** • LCD both text and graphics
- Keyboard** • Upto 8 x 8 matrix keyboard
- Memory** • > 2Mbytes available on board
- Low Power** • Many modes to choose from

Development

The PC Starter Pack provides the quickest method to get your application up & running

- Operating System** • Real Time Multi Tasking
- Languages** • 'C', Modula-2 and Assembler
- Expansion** • Easy to expand to a wide range of peripheral cards

Other Features

Real Time Calendar Clock, Battery Back Up, Watch Dog, Power Fail Detect, STE I/O Bus, 8051 interface, 68000 and PC Interface

Cambridge Microprocessor Systems Limited

CMS Units 17 - 18 Zone 'D'
Chelmsford Road Ind Est
Great Dunmow Essex CM6 1XG
E-mail cms@dial.pipex.com

Phone 01 371 875 644

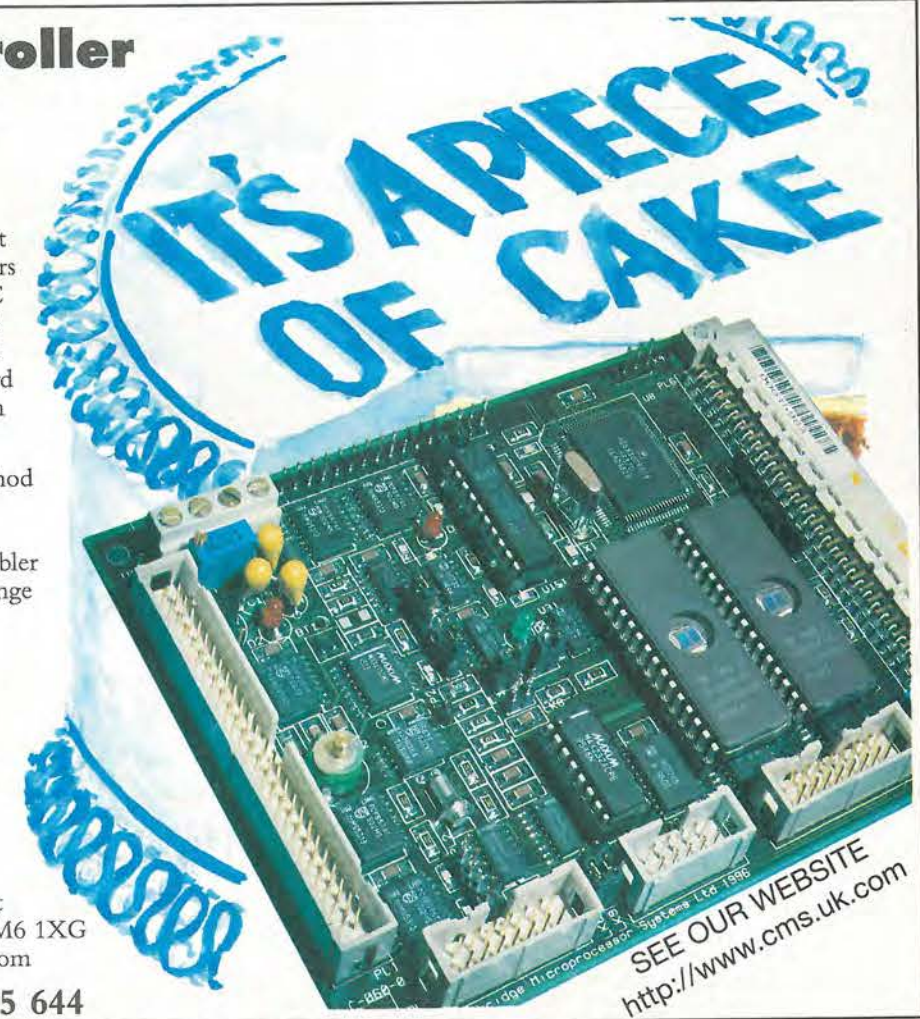

SEE OUR WEBSITE
<http://www.cms.uk.com>

2.5GHz frequency meter for under £100?

Hand-held and battery-powered, the FC2500 costs just **£99** exclusively to *Electronics World* readers.

Normally, the FC2500 2.5GHz frequency meter retails at £116.33 including VAT. But for a limited period, Electronics World in conjunction with Vann Draper Electronics is making this instrument available exclusively to Electronics World readers at the special price of **£99** – including VAT and postage, representing a discount of £17 on an already low price. Simply fill in the coupon and post it to Vann Draper at Unit 5, Premier Works, Canal Street, South Wigston, Leicester LE18 2PL. Tel. 0116 2771400, fax 0116 2773945.

Features of the FC2500

- High sensitivity at VHF and UHF
- Battery operated
- Hand-held and fits in the pocket
- 0.1Hz resolution on 10MHz range
- Measures frequency and period
- Data hold
- Relative measurement feature
- Records min., max. and average readings
- Auto power down
- High-contrast 13mm, 8-digit LCD
- Precision time-base
- Optional antenna for checking tx output



Specifications

Range 1	2.5GHz
Span	50MHz-2.5GHz
Sensitivity	≤100mV, 50-75MHz ≤50mV, 76MHz-2.5GHz
Gating	2.75s sample, 100Hz resolution 1.5s sample, 200Hz resolution 0.75s sample, 500Hz resolution 0.5s sample, 1000Hz resolution
Range 2	500MHz
Span	10MHz-500MHz
Sensitivity	≤120mV, 10-35MHz ≤50mV, 35-350MHz ≤120mV, 351-450MHz
Gating	0.75s sample, 100Hz resolution 1.5s sample, 50Hz resolution 5s sample, 20Hz resolution 6s sample, 10Hz resolution
Range 3	10MHz
Span	10Hz-10MHz
Sensitivity	≤50mV
Gating	0.5s sample, 10Hz resolution 1.25s sample, 1Hz resolution 6s sample, 0.2Hz resolution 11s sample, 0.1Hz resolution
Range 4	Period
Span	10Hz-10MHz
Sensitivity	≤50mV

Basic accuracy ±4ppm, +1d

I/p limit 5V pk-pk 2.5GHz and 500MHz ranges
250V pk-pk 10MHz and period ranges

Use this coupon to order your FC2500

Please send me FC2500 2.5GHz frequency meter at the fully inclusive special offer price of **£99** each – fully inclusive, plus AT20 Tx measurement antenna at £6.95 inclusive.

Name

Company (if any)

Address

Phone number/fax

Total amount

£.....

Make cheques payable to Vann Draper Electronics Ltd
Or, please debit my Master, Visa or Access card.

Card type (Access/Visa)
Card No
Expiry date

Please mail this coupon to Vann Draper Electronics, together with payment. Alternatively fax credit card details with order on 0116 2773945 or telephone on 0116 2771400. Address orders and all correspondence relating to this order to Vann Draper Electronics at Unit 5, Premier Works, Canal Street, South Wigston, Leicester LE18 2PL.

*Overseas readers can also obtain this discount but details vary according to country. Please ring, write or fax to Vann Draper Electronics.

ANCHOR SUPPLIES Ltd

The Cattle Market Depot
Nottingham NG2 3GY, UK

Telephone: +44 (0115) 986 4902/
+44 (0115) 986 4041 24hr answerphone

Fax: +44 (0115) 986 4667

ONCE IN A LIFETIME OFFER MANUFACTURERS SURPLUS OSCILLOSCOPES

Every one is NEW and BOXED and comes complete with Probes, leads and Manuals
Note: We can't advertise the makers/distributors name but be assured it is one of the UK's Leading Electronics Companies

DSM 3850A Hand held Digital storage Oscilloscope

50MS/sec, 8 bit resolution. 2 channels
5" LCD display Built-in RS232 port
Horizontal and Vertical Cursors
Built-in 4 digit Digital Multimeter featuring
AC/DC Volts/Current. Resistance. Conductivity. Capacitance
Frequency, Data Logger
Internal battery/ext DC operation (7.5-9V DC @ 300mA)
Size only: 50mm x 235mm x 153mm Weight only 11.1kg
Complete with Soft Carry Case
VERY LIMITED QUANTITY.
ONLY £399+£9.95 UK del+vat

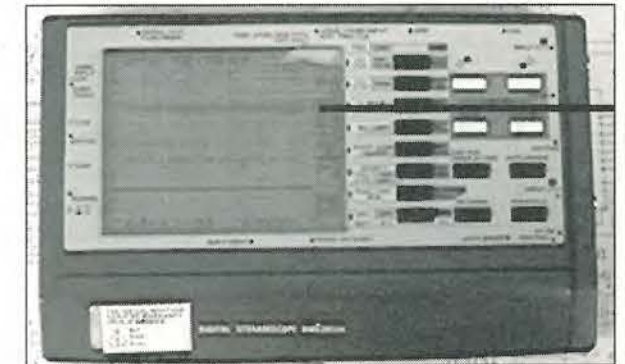

DTV 100 3 channel 8 trace 100MHz Oscilloscope

DC-100MHz (-3db) bandwidth
Twin timebases with Delay
Size: 146mm x 360mm x 384mm Weight 10kg
Including Probes, Leads, Manual
VERY LIMITED QUANTITY.
ONLY £399+£9.95 UK del+vat

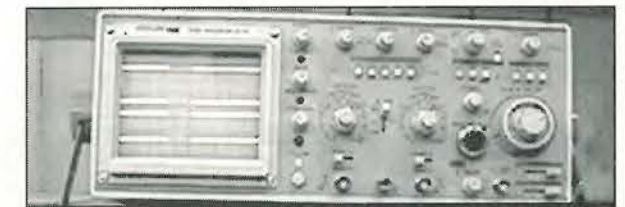

DTS 40 40MHz Dual channel Digital storage Oscilloscope

On Screen Readout with Cursors. DC-40MHz (-3db) Bandwidth
20MS/sec max Digital sample rate giving an effective 4MHz B/W
Size: 145mm x 357mm x 445mm Weight 10.5kg
Including Probes, Leads and Manual
VERY LIMITED QUANTITY.
ONLY £399+£9.95 UK del+vat



DTA 20/DTA 40...20/40 MHz Twin channel 4 trace Oscilloscope

Size: 140mm x 335mm x 375mm Weight 7.3kg
Including Probes, Leads and Manual
VERY LIMITED QUANTITY.
DTA 20 ONLY £225+£9.95 UK del+vat
DTA 40 ONLY £299+£9.95 UK del+vat



**NOTE: All Surplus Equipment is Unconditionally Guaranteed for 30 Days
OPEN 6 DAYS A WEEK**

Mon-Fri 9am-6pm Sat 8am-4pm

**NO APPOINTMENTS NEEDED. CALLERS ALWAYS WELCOME
NATIONAL AND INTERNATIONAL MAIL ORDER A SPECIALITY**

VISIT OUR NEW WEB SITE
<http://www.anchor-supplies.ltd.uk>
e-mail sales@anchor-supplies.ltd.uk

Please note: Requests for catalogues MUST be accompanied by a first class SAE



SMART CARD READER/PROGRAMMER



Extremely versatile unit to enable the user to Read and Write to all types of Smart Card. A must for the serious development engineer.

Requires an IBM PC and a power supply between 12-18 volts.

Supplied with all operating software and 'useful' data on various subjects relating to Smart Cards.

• £79.95

UNIVERSAL PIC PROGRAMMER

Runs on IBM PC, plugs into centronics printer lead and requires 12-18 volt power supply.

Powerful menu-driven software to Read, Write, Copy and Edit PIC 16C54, 55, 56, 57, 58A 61, 64, 65, 71, 74, 84, 620, 621, 622 & Memory Chip 24C01 thru to 24LC65.

Supplied with operating software and 12 months parts and labour guarantee.

• £69.95



GAL/PAL PROGRAMMER



- Programs 16V8, 16V8A, 20V8, 20V8A, 20V8Z.
- Works on IBM PC compatible, laptops, Notebooks etc.
- Plugs in Centronics port.
- Easy to use software.
- Supplied with PLAN Logic compiler software.
- Complete with examples, connection lead, PSU and user manual.
- £89.95

PICICE II

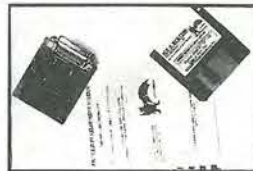

OSC2 output, RTCC input
On board 4 channel A/D for PIC16C71 with A3 ref or VCC ref
Analogue to Digital conversion 17us.
Top quality components used throughout.
Complete package consists of:-
PIC software for 16C54-55-56-57-71-84, PIC ICE hardware, leads and headers to connect to target board, ASM examples and Circuit Schematics for hardware projects.

• £99.95

CROWNHILL ASSOCIATES LIMITED
THE OLD BAKERY
54 NEW BARN ROAD
ELY
CAMBS CB7 4PW

Tel: 01353 666709
Fax: 01353 666710

MASTERCARD
VISA
SWITCH
accepted

Visit our WEB site at
<http://crownhill.cambs.net>

CIRCLE NO. 127 ON REPLY CARD

MEGAPROM II



- Programs from 2k to 8 Meg
- Programming voltage from 12-25 volt covering all types of Eprom, EEprom and Flash memory.
- Supplied with operating software and 12 month guarantee.
- £89.95

NEW Radio Receiver Trainer
An Invaluable Learning and Design Tool for all Experimenters **NEW**

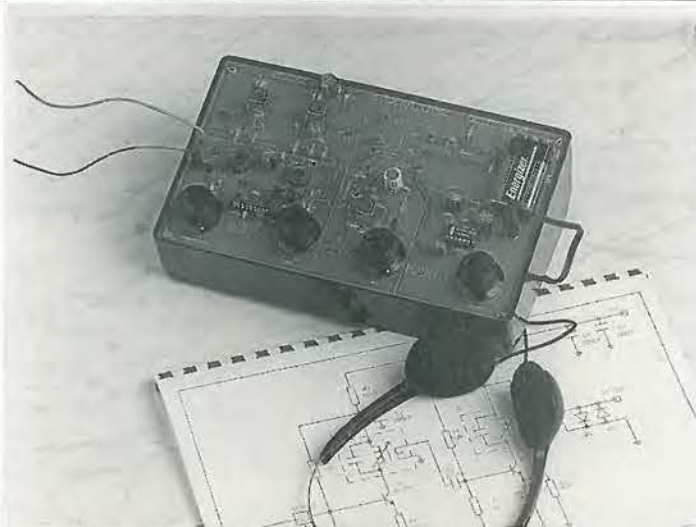

The Radio Receiver Trainer contains nine receiver building blocks and a comprehensive training manual.

Simply connect the building blocks to build AM, SW, Superhet and Direct Conversion receivers. Decode SSB, CW & FM! Use proven building blocks to develop and test your own designs.

Full technical support and advice given.

Pricing: Complete £129.00
Kit £89.00
(Kit excludes case & headphones)

P&P is £5 (UK), £8 (EC), £12 (World)
Add 17.5% Vat to Total Price

- Building Blocks:
- RF Input Tuner
 - RF Oscillator
 - Mixer
 - IF Filter
 - IF Amplifier
 - AM Detector
 - Beat Frequency Oscillator
 - Audio Filter
 - Audio Amplifier

The manual contains complete schematics and theory of operation of all the building blocks. Use this trainer to receive frequencies from 500KHz to 110MHz!

A set of proven alternate building block designs are included in the manual for you to get started with your own designs. There is no need to get your complete receiver design working all at once. Build and test each block one at a time.

Mail Order To: Pyramid Electronics Ltd.

204 Ferndale Road, Brixton, London SW9 8AC
Phone (0171) 738-4044 Fax (0171) 274-7997

Out of office ordering by answering machine.



CIRCLE NO. 128 ON REPLY CARD

ELECTRONICS WORLD December 1997

Seeing through noise II

Patrick May extends his new noise theory to deal with surface diffusion as a 1/f noise source in thin metal films and explains how this work leads to a better understanding of low-frequency noise in thin-film resistors and semiconductors.

I show here that the impulses due to the emission of electrons from the surface of a continuous thin film of metal into the electron cloud at the surface produce a diffusion current in the metal. For the first time, I show that this effect in thin films equates to 1/f noise.

My mathematical analysis reveals that this gives rise to a time varying component of electron carrier density in a layer near the surface; the square of the Fourier transform of this time function has a 1/f characteristic which manifests itself as 1/f noise.

Calculations of this noise are made using a modified form of the Richardson-Dushman equation to estimate the rate of electron emission from the surface. These show that the estimated noise in copper thin films is equal to that measured and reported by others in the field. Also, there is good agreement with the strong temperature dependence, observed during experiments.

Current thinking on 1/f noise

In semiconductor devices, holes and electrons recombine in the surface under the auspices of the 'fast surface' states. It has been shown that the impulses produced by the ejecting carriers give rise to a diffusion current which produces a time varying component in carrier density in a layer near the surface¹.

It is assumed that a similar phenomenon occurs in metals. But in the case of metals it is the thermionic emission of electrons from the bulk to the 'electron cloud' at the surface which provides the impulses. The analysis for a semiconductor strip has

already been presented^{1,2}. A similar analysis for a thin metal film is presented here. Next, I present a study of the thermal emission of electrons from the surface of a metal into the 'electron cloud' surrounding the surface.

Electron emission

Figure 1 shows a thin film resistor on a substrate. The rate of electron emission per unit area from the bulk into the 'electron cloud' covering the surface of the metal is derived from the Richardson-Dushman³ equation,

$$J = AT^2 e^{-\frac{\phi}{kT}} Am^{-2} \quad (1)$$

where J is the current density, A a constant for metals, T the absolute temperature, k Boltzman's constant and ϕ the work function of the metal.

The current is due to electrons having an energy greater than the work function. The energy of electrons emitted from the surface into the 'electron cloud' is much lower. According to the image theory, there is no potential barrier at the surface, but the image theory does not hold for short, atomic, distances from the surface. If there is a small barrier potential ψ at the surface of the metal, equation 1 must be modified³ as,

$$J = AT^2 \left[e^{-\frac{\phi}{kT}} + \frac{1}{4} e^{-\frac{2\phi}{kT}} + \frac{1}{9} e^{-\frac{3\phi}{kT}} \right] Am^{-2} \quad (2)$$

Electron emission per unit area, ν , is given by J/e where e is the electron charge.

Metal thin-film 1/f noise - a thermal problem

One of the earliest manifestations of 1/f noise was in directly-heated thermionic valves, these had tungsten filaments which also formed the cathode. In the model I propose here, I show that 1/f noise in thin metal films is due to thermionic emission from the surface of the metal.

Aspects of the analysis are based on thermionic valve technology dating back to the early part of this century.

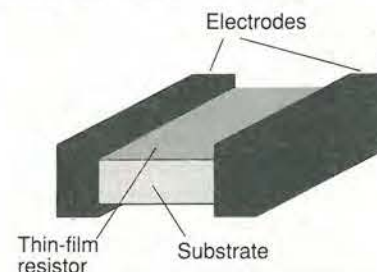

A practical application of this work is in precision thin metal film resistor design. The 1/f noise in the film can be estimated over a wide range of temperatures using constants that are readily available in physics text books.

The ideas presented here reinforce the surface-diffusion theory of 1/f noise in semiconductors^{1,2,14}. They can be used to study 'fast surface states' in semiconductor devices, enabling optimisation of low-frequency noise performance.

The constants involved in the calculations are readily available in physics textbooks. There is no credible alternative model that predicts 1/f noise in thin metal films and no attempt has been made to explain its strong temperature dependence.¹¹



Picture courtesy Alexander S Popov Museum, St Petersburg

Books to buy - domestic security systems

Build or improve your own intruder alarm system

House break-ins have increased threefold in the UK over the last 20 years. Few have not been touched by the affects, even if only through the experience of family and friends who have suffered a burglary. There is a way to reduce significantly the chances of being targeted by thieves: fit an alarm. But isn't that expensive and complicated? Not if you build your own system. This book shows you how, with common sense and basic DIY skills, you can protect your home.

Every circuit is clearly described and illustrated, and contains components that are easy to source. Advice and guidance are based on the real experience of the author who is an alarm installer, and the designs themselves have been rigorously put to use on some of the most crime-ridden streets in the world.

To illustrate the principles, Tony Brown uses two examples of houses, one a typical semi-detached home and one an average

three-bedroomed detached bungalow (for which designs would also suit an apartment). Working systems are shown in operation. Designs include all elements, including sensors, detectors, alarms, controls, lights, video and door entry systems.

*build your own security system
*practical guide to domestic security, including basic systems
*includes all elements including sensors, alarms and lights

CONTENTS: Input sensors; System control architecture; Output signalling devices; Installation; Testing and maintenance; Existing systems; Security lighting; Video camera and door entry systems; Suggested tooling; Index

ISBN 0 7506 3235 6 : 192pp : 216 x 138 mm : 70 line illustrations : Paperback :

UK £15.00 Europe £17.00 ROW £19.00

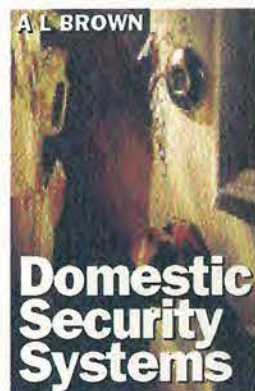

Intruder Alarms

Specification, installation and maintenance. Gerard Honey

This book covers Intruder Alarm Systems (C+G 1851 syllabus) as well as providing the underlying knowledge required to achieve a level 2 NVQ (National Vocational Qualification) in Understanding, Specifying, Installing and Maintaining Intruder Alarms (C+G 1863, 1864 and 1865). Familiarity with the contents of this book are required before an award will be made.

Gerard Honey is an experienced installer and writer and has used that experience to produce a book that not only provides essential information in a way that is easy to follow and learn, but also makes the book a fine practical source of advice. Each chapter contains summaries, self-tests and other features designed to help the student to understand and gain knowledge easily. Intruder Alarms has been published with the help of SITO, the Security Industry Training Organisation, who design courses and organise training for security installers and professionals.

*Only course book written for syllabus for Security NVQ
*Comprehensive study of intruder alarms
*Author is a practising international security systems expert

CONTENTS: Intruder alarm systems; Circuitry; Detection devices; Power supplies; Control equipment; Signalling systems; Wiring systems; Inspection of the mains supply; Commissioning, maintenance and fault finding; Index

ISBN 0 7506 3238 0 : 192pp : 234 x 156 mm : 50 line illustrations : Paperback :

UK £27.50 Europe £29.50 ROW £37.50

Return to Jackie Lowe, Room L333, Quadrant House, The Quadrant, Sutton, Surrey, SM2 5AS

Please supply the following titles:

Qty	Title or ISBN	Price
Total		

**** All prices on these pages include delivery and package ****

Name _____

Address _____

Postcode _____ Telephone _____

Method of payment (please circle)

Access/Mastercard/Visa/Cheque/PO

Cheques should be made payable to

Reed Business Information

Credit card no _____

Card expiry date _____

Signed _____

Please allow up to 28 days for delivery

Microstrip made easy

Nick Wheeler explains that although there are complex procedures for designing high performance microstripline circuits, a few shortcuts result in a technique that is quick and easy to implement yet more than adequate for most applications.

Micro stripline consists of conductive traces of defined width on low-loss dielectric superimposed on a conducting ground plane. It can be created by etching one side of ordinary double-sided printed circuit board material.

Stripline on the other hand consists of flat, thin conductors sandwiched between two ground planes and usually embedded in dielectric. It has many useful properties such as inherently good screening, but it is difficult to use and is not further discussed here.

For micro-stripline, glass-reinforced epoxy is the preferred dielectric. The cheaper phenolic type is too lossy, and PTFE or ceramic substrates are both much more costly - PTFE boards cost in the region of £100 a square foot - and are difficult to work with. On the other hand, PTFE boards are usable far into the microwave region. In this article I refer only to G-10 and FR-4 substrates. Apart from being fire-resistant, FR-4 is very similar to G-10.

This article is directed towards those of you wanting to make high-performance equipment with relatively limited resources. I have interpreted this as meaning that trace widths are defined to an accuracy of no better than 0.01 in. This means, roughly, that characteristic impedance Z_0 of a typical trace will be accurate to one or at worst a few percent.

A down-to-earth attitude is adopted in the ARRL Handbook.¹ What I have done below

is to explain how their results can be replicated, while referring to more rigorous treatments of the subject to reassure readers that readily available techniques are virtually indistinguishable from the very best that can be done.

Microstripline principles

Most microstripline calculations refer to traces of width W on an infinite layer of dielectric whose dielectric constant is ϵ_r , and of thickness h backed by an infinite ground plane, Fig. 1.

In practice - and more so with increasing frequency - the electric field is concentrated in the volume of dielectric lying directly under the trace. However, some of the field is in air, leading to the concept of ϵ_{eff} , the effective dielectric constant, which is lower than that of the dielectric.

The greater the width of the trace the more ϵ_{eff} tends towards ϵ_r . If the ground plane and dielectric are truncated, as in Fig. 2, there is little effect upon Z_0 if $T > 2W$. If only the dielectric is truncated², as in Fig. 3, Z_0 is raised by less than 0.5% when T/W is greater than 0.5.

Because W/h is dimensionless, if the dielectric thickness is halved, the same Z_0 is achieved with half the trace width. There are many published formulae for accurately calculating Z_0 . These take into account the thickness t of the trace and even whether the etching process has resulted in a trace of

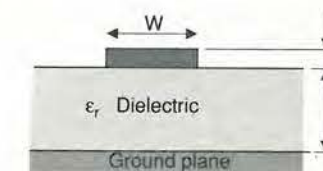

Fig. 1. Most microstrip calculations refer to traces of width W on an infinite layer of dielectric with constant ϵ_r , and of thickness h backed by an infinite ground plane.

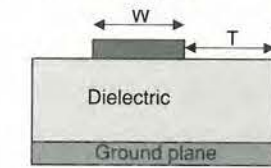

Fig. 2. In this microstripline example, both ground plane and dielectric are truncated.

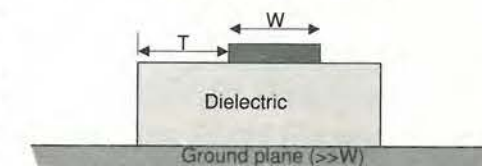

Fig. 3. If only the dielectric is truncated, Z_0 is raised by less than 0.5% for when T/W is more than 0.5.

trapezoidal rather than rectangular cross section.

For traces produced by etching ordinary 1oz circuit board material, with a thickness t of 0.0014in, and for typically useful values of Z_0 , these considerations are very much second-order effects. The effect of varying t from 0.0014in to 0.0056in on ordinary G-10 board of 0.0625in thickness is to reduce the trace width for $Z_0=50\Omega$ from 0.11984in to 0.11691in. Incidentally, the trace width for 50 Ω on this board is commonly specified as 0.1in but 0.12in is clearly a better approximation. This can be achieved by carrying out the following.

Evaluating complex formulae is tedious and there are many published tables relating W/h , ϵ_r and Z_0 . The graph of Fig. 4, derived from several sources, gives trace widths for a useful range of Z_0 using commonly available double-sided glass-epoxy pcb material. It should be accurate enough for most purposes. This is particularly so since G-10 and FR-4 are supplied by various manufacturers with ϵ_r varying over a range from 4.22 to 4.9. The most commonly quoted range though is 4.3-4.5.

Applying microstripline

There are in print several well-documented project descriptions.¹ These give a good overview of what can be done using this technique. Quarter wavelength, or $\lambda/4$, transformers for frequencies around 1GHz are particularly easily implemented, but bear in mind that the electrical length of microstripline is the reciprocal of $\sqrt{\epsilon_{eff}}$ multiplied by the physical length. The term λ_g is commonly used to describe the on-board wavelength.

Perhaps one of the most useful applications is in conjunction with monolithic microwave ICs, or mmics, as these are 50 Ω devices in

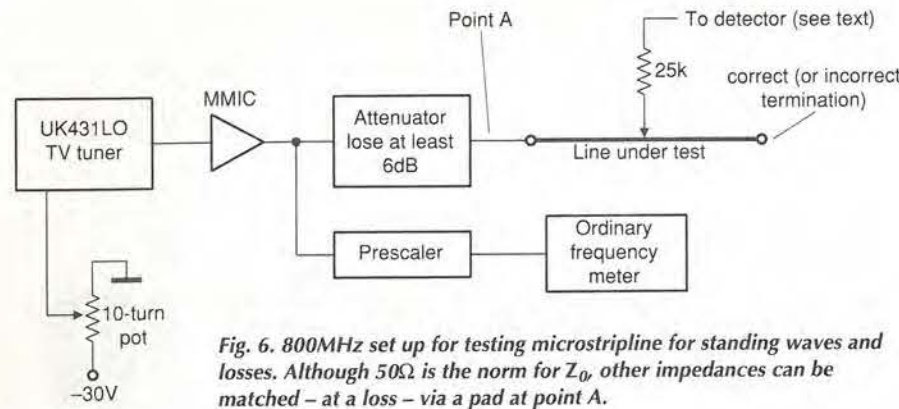

Fig. 6. 800MHz set up for testing microstripline for standing waves and losses. Although 50 Ω is the norm for Z_0 , other impedances can be matched - at a loss - via a pad at point A.

most cases. On the other hand, many other devices can be matched.

It is important to bear in mind that the cross-section of the trace of a typical microstripline is very small. If it is operated at significant power levels in a mismatched condition, destructive current antinodes may lead to failure.

Some general-purpose microstripline applications are dealt with below.

Applying microstrip

As reference 1 suggests, microstripline can be implemented by attaching, with superglue, 0.1in strips, or other widths, of thin copper foil to the plain side of single-sided pcb material. This works quite well, but I will now describe a reproducible photo-etch approach.

I use Windows 95 with one of the many available graphic design programs, in my case *Serif Draw Plus*, an *HP Deskjet 693C*, and the appropriate Premium Transparency Film. This combination I can vouch for, but there are doubtless other suitable films and many other

software packages and printers that will work too. Do not attempt to use films designed to take spirit-based felt pens or films made for overhead projector transparency work.

The transparencies produced are fine as masters for conventional photo-etching. It is important to remember that printer ink takes a long time to dry on transparency film. I recommend leaving for at least half an hour. I will not describe this well-known technique, except to point out that the transparency should be flipped so that the pattern ends up in face down, in direct contact with the pcb material before exposure.

Serif Draw Plus V2.0 has the option of selecting a grid based on 0.1in, with a spatial increment of 0.01in. You will suffer serious problems if you try to create circuit boards on a metric grid of any coarser resolution than this. I've tried it.

Graphic programs define line widths in 'points.' As far as *Serif Draw* is concerned, 7 points closely approximate to 0.1in*. This makes 8 points a good line width for 50 Ω on 0.0625 G-10 board.

Most transmission-line configurations can readily be implemented in microstripline. References 1-3 give many examples. The attraction here is that any Z_0 , within a range generally quoted as being from 16 Ω to 125 Ω can be achieved without resorting to tedious methods such as replacing the inner conductor of co-axial cable with wire of a different diameter.

A few practical points. Parallel traces, separated by a distance of W or less couple and can be used to effect directional couplers. Undesired coupling can be virtually eliminated by making the spacing $>2W$. The design parameters for couplers are highly interactive, and the empirical approach - i.e. suck it and see - may be the least difficult.

Bends can be radiused or mitred. Bends through any angle with a radius, to the centre line of the trace, $>4W$ do not have a significant effect on standing-wave ratio. Mitred bends, which occupy less board space, are theoretically complicated. However, using the approach of Fig. 5 seems to yield generally satisfactory results.

The advantage of using the computer-graphic

*A point is 1/72 of an inch - Ed.

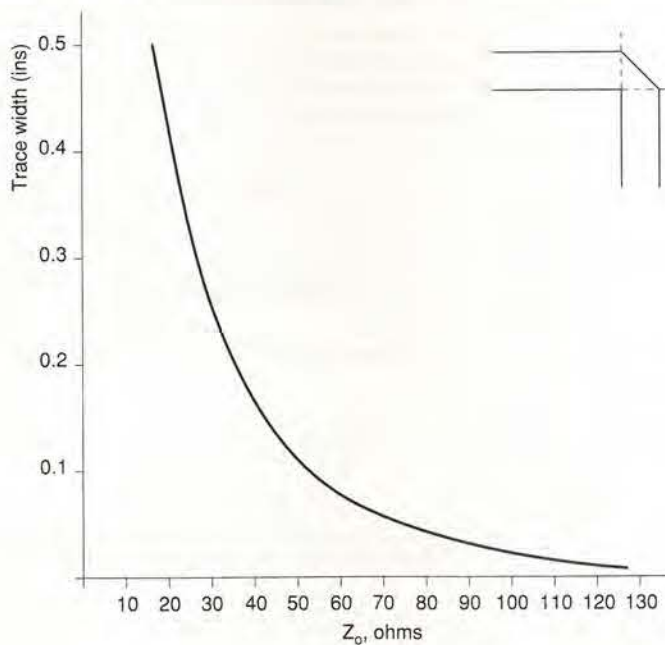

Fig. 5. Not an ideal microstripline bend shape, but it does the job for most applications.

Fig. 4. Derived from several sources, this graph gives trace widths for a useful range of Z_0 , assuming common glass-epoxy pcb.

ic approach is that your artwork is stored and can easily be altered before committing to transparency. Good results - within the limitations of the transfer sheets available - can be obtained much more directly by the use of etch-resistant pcb transfers, though they can save a lot of time in producing artwork for photo-etching.

Making measurements

In many cases, the success of a microstripline circuit design can be estimated by driving it from a source of the right impedance, terminating it correctly and looking for standing waves or excessive losses.

I made a line 210mm long on G-10 board. One source quotes ϵ_{eff} for a 50 Ω line as about 3.4, when ϵ_r is 4.4. Using a test frequency of 800MHz, this accommodates just over a wavelength. An ϵ_r of 4.5 is favoured in reference 1.

Figure 6 shows a test setup. The signal source is a *UK431LO* television tuner, which has a local-oscillator output ranging from 431 to 900MHz. Many other tuners have local-oscillator outputs. This signal is buffered by a suitable mmic. Almost any of those currently available will suffice.

Frequency is measured using the gigahertz

prescaler of reference 4. The detector probe is connected to the 75 Ω input of the low-cost spectrum analyser described in reference 5.

A 25k Ω series resistor at the probe tip ensures negligible loading effects when applied to the line under test. Measurements are made by the null method of varying the attenuator to produce the same outputs at the points being tested.

As the spectrum analyser uses a television tuner there is obviously plenty of scope for the use of other tuners. Although I have not tried it, the raw intermediate frequency from any tuner could be amplified and inspected on a modest oscilloscope.

In the case of my test line, probing it when properly terminated with 50 Ω disclosed no perceptible standing wave pattern. Operating with no termination produced deep voltage nodes separated by 100mm - almost exactly - on the board. These are, of course, $\lambda_g/2$ apart.

Working backwards through the relationships outlined above, you can deduce that in this case the apparent ϵ_{eff} is 3.5. This degree of agreement lies well within the limits which might be expected.

An error of 1% in the measurement of the distance between the nodes could account for more than half the difference. Because of the element of empiricism inherent in all

microstripline calculations this seems to be a very good first attempt, and easily good enough for almost all applications.

In summary

I have shown that microstripline is a versatile technique, easily implemented to useful accuracy for many uhf applications. I recommend a computer-graphic approach for the generation of the artwork, since this gives quite precise control over trace widths.

The rigorous treatments of references 2 and 3 are available to those of you wanting to use more precise techniques. This will not normally be necessary unless high power levels are to be involved.

References

- ARRL Handbook.
- Waddell, BC, *Transmission Line Design Handbook*, Artech House 1991.
- Edwards, TC, 'Foundations for Microstrip Circuit Design', Wiley 1981
- Wheeler, NPE, Gigahertz prescaler. *Electronics World*, Sep. 1996
- Wheeler, NPE, 'Spectrum Analyser on the Cheap,' *Electronics World*, Mar 1992.

The Autorouter for EASY-PC!

MultiRouter is "the best Autorouter that I have seen costing less than £10,000!" R.H. - (Willingham, UK)

- Award Winning MultiRouter uses the latest 32 bit, Shape based, Rip-up and Re-try Technology.
- From single sided to 8 layers!
- 100% Completion where other autorouters fail!
- 100% routed 140 Components on a 210mm x 150mm board in less than 10 minutes! (75MHz Pentium)
- From £295! - Could Easily Pay For Itself On The First Project!

Prices exclude VAT& P&P

Number One Systems

Write, fax, phone or e-mail for full information.

UK/EEC: Ref: WW, Harding Way, St.Ives, Cambridgeshire, ENGLAND, PE17 4WR. e-mail: sales@numberone.com
Telephone UK: 01480 461778 (7 lines) Fax: 01480 494042
International +44 1480 461778/494042

USA: Ref: WW, 126 Smith Creek Drive, Los Gatos, CA 95030
Telephone/Fax: (408) 395-0249

CIRCLE NO. 131 ON REPLY CARD

http://www.numberone.com

Radio reflections from Russia

St Petersburg's Alexander Popov Museum of Communications – one of the world's oldest technical museums – houses a wealth of early British wireless apparatus – as Khatskel Ioffe reveals.

Founded in 1872 as a telegraph museum, the Alexander S. Popov Central Museum of Communications in St. Petersburg has a collection of British equipment dating from the earliest stage of the development of wireless. Building on last month's article, which described artefacts ranging from Flemming's diode to a Marconi direction finder, this article covers our Marconi 250-1300m receiver, 500W transmitter and a wavemeter – Fleming's cymometer.

A standard for 250 to 1300m

A receiver for 250 to 1300m from our collection is shown in **Photo 1**. An identical receiver is depicted in a magazine printed in 1915, where it makes part of a field wireless outfit.¹ At around the same time, a receiver for this range also made part of the Marconi Company's 0.5, 1.5 and 5kW ship and coastal wireless stations.



Photo 1. This Marconi Company receiver from circa 1915 was designed for reception between 250 to 1300m. It represented a standard in coastal and marine communications.

We consider this receiver to be Marconi's standard apparatus for 250 to 1300m during WWI. The receiver is complete with two carborundum contact detectors, one of which was a spare.

The receiver also has terminals for connecting a magnetic or another external detector. This allowed reception of strongly damped oscillations in addition to the undamped or feebly damped oscillations then coming into use.

The receiver has two subranges, 250–800m, and 500–1300m, selected by placing an aerial tuning capacitor in parallel or in series with an aerial tuning inductance coil, respectively. Placed into the aerial circuit, in addition to the variable inductance coil, is a moving detector-coupling coil.

Along with the Billi condenser, the detector and the telephone, this coil makes up the detector circuit. Connected to the receiver is an external storage battery which secures a required mode of operation of the receiver using a potentiometer. Provided along the periphery of the top panel are holes for screws fastening the receiver at its location on the frame of the transmitter-receiver station.

Our museum has two such receivers.

500W field transmitter

A wireless transmitter with a rotary spark discharger for a 0.5kW field wireless station mounted on a cart is shown in **Photo 2**. In the late 1900s and early 1910s wireless telegraph with a shock-excited transmitter generating a musical spark were becoming popular.

The Marconi Company obtained this effect by means of a rotary, toothed, spark discharger wherein a spark arose as each tooth passed under fixed high-voltage electrodes. The use of shock excitation meant a transition to feebly damped oscillations, which increased the energy sent by the station and enhanced its efficiency.

Installed on a two-wheel cart, the Marconi Company's 0.5kW wireless station was used in the Russian Army during WWI. In our set, a 7hp air-cooled two-cylinder Douglas petrol motor and an electrical generator are installed on a cast-iron base. The shafts of the motor and generator are connected by a bilateral coupling. A toothed spark discharger is

fixed on the shaft of the electrical generator.

The spark discharger is separated from the electrical generator by a chamber made of an aluminium alloy. The spark discharger has a copper disc, 7mm thick, fixed on a hard-rubber hub, through which a shaft supported in ball bearings passes.

Mounted in the chamber case are two fixed electrodes constituted by two copper rods, 4mm in diameter, placed inside hard-rubber insulators, the disc tooth-to-electrode spacing being set at 0.15–0.2mm.

The electrical generator has a stator with 12 poles arranged as 6 pairs. In the magnetic field formed by these poles, an anchor rotated with dc and ac windings. The current of the dc winding was fed into the collector and used in the excitation circuit while the current of the ac winding was fed into the rings. The ac voltage, transformed via an external high-voltage transformer, was fed to the electrodes of the spark discharger.

The spark discharger is of the synchronous type. It has the same rotational speed as the electrical generator and discharges at each peak of the ac voltage, ie at each alternation. Running at 1900rev/min, the electrical generator produced a 190Hz alternating current and the spark discharger produced 380 discharges per second. This corresponds to a relatively good tone – the musical spark effect.

On air in the air

The transmitter of an aeroplane wireless is shown in **Photo 3**. This is one of the first transmitters designed for the purpose.

It dates back to the times of WWI. It is a low-power spark transmitter consisting of an induction coil with a mechanical interrupter, an adjustable spark discharger in the form of two cylindrical aluminium electrodes, and an oscillatory circuit. The latter is comprised of a fixed capacitor and a variometer whose fixed coil is placed in the aerial circuit.

Using the variometer, the 230–430m wavelength range is covered. The induction coil was operated from an external dc power supply. A telegraph key was hooked into the power supply circuit. At the front of the transmitter case, access is provided to the spark discharger. Also provided is an inspection window to inspect the spark discharger.

Fleming's cymometer

The earliest type of the Marconi Company's wavemeter was Fleming's cymometer. I believe that the instrument that we have dates from 1906–1907.

This cymometer opened up the use of scientific methods for tuning transmitters and receivers. Earlier methods involved trial and error. It comprises a variable inductor and a variable capacitor. In the inductor, a coil of bare copper wire is wound around an ebonite tube. The self-inductance is variable by means of a slide contact.

The variable capacitor – a Billi condenser – consists of two thin-wall brass tubes separated by a hard-rubber bushing. The capacitance is varied by moving the outside tube using a handle. As the tube moves, the slide contact of the coil also moves so that the values of both elements of the measurement circuit are varied at the same time and in the same direction.

In order to find the instant that the measurement circuit is at resonance with the transmitter frequency, a neon tube was connected in parallel to the capacitor.

The scales of the instrument are calibrated in the values of an 'oscillation constant' – the term used by Fleming to denote the expression \sqrt{LC} . There are also scales for wavelength in metres, wavelength in feet, and the numbers of oscillations per 1/1,000,000th of a second.

It is known that the Marconi Company produced four types of cymometers to cover the ranges 33–700m, up to 1400m,

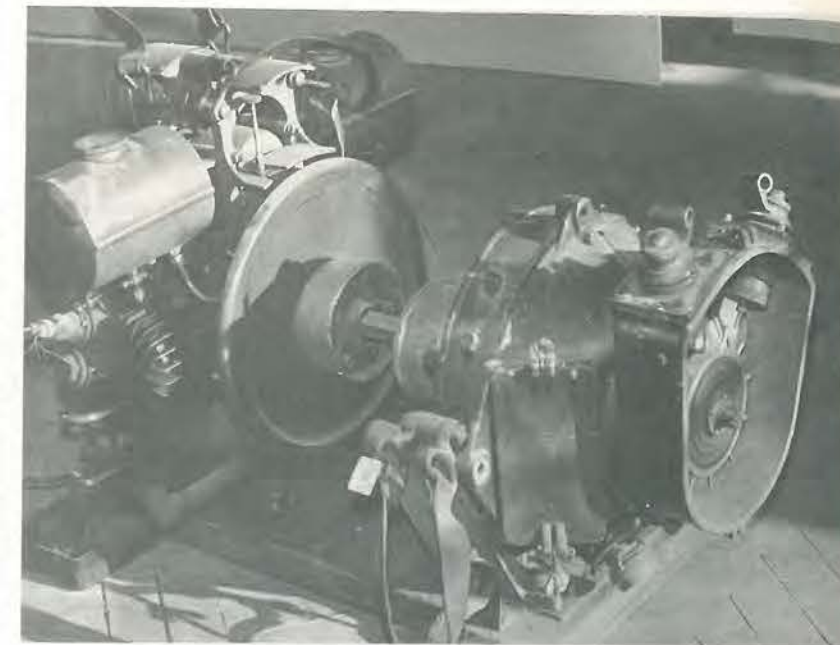

up to 2000m and up to 3000m.

Our cymometer is for 33–700m. To determine the wavelength of a transmitter, the cymometer was installed parallel to an antenna section. The operator moved the handle of the instrument in either direction so as to attain the brightest glow of the neon tube. The scale indicator, rigidly bound with the handle lever, ensured direct readings of the wavelength and frequency from scales.

To measure capacitance and inductance, the operator connected these components to a standard self-inductance or standard capacitance, respectively. The components excited oscillation via an ancillary inductor with a spark gap. The cymometer was used to determine \sqrt{LC} , whereafter the unknown value of C or L could be calculated.

Rounding up

All of the above-described apparatus were received by our museum in the 1920s from Russia's various communications establishments and educational institutions.

The British equipment presented in this article along with the apparatus of the Popov-Ducruet, Slaby-Arco and Telefunken systems of the early 20th century, also in the keeping of our museum, preserves the memory of the first steps in the development of wireless worldwide.

I cannot guarantee the accuracy of the dating and operating descriptions of the instruments described since my collection of literature is limited. Any corrections will be gratefully received. ■

Translated from the Russian by L.N.

Kryzhanovsky. Khatskel Ioffe is with the A.S. Popov Central Museum of Communications, St. Petersburg.

Reference

1. 'Wireless Telegraphy in the War', *The Wireless World*, August 1915, p. 299.

Photo 2. Transmitter apparatus with rotary discharger for a 0.5kW field wireless station from circa 1916.

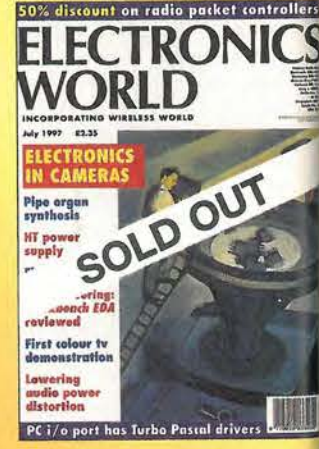

Photo 3. Transmitter for aeroplane wireless station from circa 1915 – one of the first transmitters designed specifically for aviation.

Free circuit design demo disk with every order*

BACK ISSUES

Back issues of Electronics World are available, priced at £2.50 in the UK and £3.00 elsewhere, including postage. Please complete the coupon and send with correct payment to:
Electronics World, Quadrant House, The Quadrant, Sutton Surrey, SM2 5AS.
 Note that not all issues are available and please allow 21 days for delivery.



*While stocks last.

ELECTRONICS WORLD
INCORPORATING WIRELESS WORLD

READER INFORMATION SERVICE

For more information about any of the products or services in this issue of **ELECTRONICS WORLD**, simply ring the relevant enquiry number. Enquiry numbers may be found at the bottom of each individual advertisement.

- 101 102 103 104 105 106 107 108 109
- 110 111 112 113 114 115 116 117 118
- 119 120 121 122 123 124 125 126 127
- 128 129 130 131 132 133 134 135 136
- 137 138 139 140 141 142 143 144 145
- 146 147 148 149 150 151 152 153 154
- 155 156 157 158 159 160 161 162 163
- 164 165 166 167 168 169 170 171 172
- 173 174 175 176 177 178 179 180 181

Name _____
 Job title _____
 Company Address _____
 Telephone _____ **DECEMBER 1997**
 Only tick here if you do not wish to receive direct marketing promotions from other companies.

Newsagent order form

Pass this order form to your newsagent to ensure you don't miss the next issue of *EW*.

To
 (name of Newsagent)

Please reserve me the January issue of *Electronics World* - on sale 4th December - and continue to order every month's issue until further notice

Name.....

Address.....

Thank you

Subscribe today!

Guarantee your own personal copy each month

Save on a 2 year subscription

ELECTRONICS WORLD
INCORPORATING WIRELESS WORLD

Subscribe today!

Guarantee your own personal copy each month

Save on a 2 year subscription

ELECTRONICS WORLD
INCORPORATING WIRELESS WORLD

Issue (Month/Year)	Quantity	Price	Total
Total Order			

Name _____
 Address _____
 Post code _____
 Method of payment (please circle): Access/Mastercard Visa Cheque
 Cheques payable to Reed Business Publishing
 Credit Card Number _____
 Signed _____ Expiry Date _____

SEE OVER!

ELECTRONICS WORLD
Reader Information Service
Reed Business Information
Oakfield House
Perrynount Road
Haywards Heath
Sussex RH16 3BR

Business Reply Service
Licence No. CY711

Do not affix postage stamps if posted in
Gt Britain, Channel Islands, N Ireland
or the Isle of Man.

Postage will
be paid by
licensee



ELECTRONICS WORLD
INCORPORATING WIRELESS WORLD

SUBSCRIPTION CARD

Please enter my subscription to ELECTRONICS WORLD. I enclose Cheque/Eurocheque to the value of £ made payable to Reed Business Information

Please charge my Mastercard/Visa/Amex account

With £ Expiry Date

Signature

Name

Job Title

Address

Postcode

Tel: Country

Table with 2 columns: Subscription Rates, Price. Includes UK 1 year (£32), UK 2 years (£58), Student rate (£21), Airmail, Europe 1 year (£46), Europe 2 years (£83), Rest of the world 1 year (£56), Rest of the world 2 years (£101), Surface mail 1 year (£37).

Post to:
ELECTRONICS WORLD
P.O. Box 302
Haywards Heath,
West Sussex RH16 3DH UK.

CREDIT CARD HOTLINE
Tel: +44 01444 445566
Fax: +44 01444 445447

Please tick here if you do not wish to receive direct marketing-promotion from other companies

ELECTRONICS WORLD
INCORPORATING WIRELESS WORLD

SUBSCRIPTION CARD

Please enter my subscription to ELECTRONICS WORLD. I enclose Cheque/Eurocheque to the value of £ made payable to Reed Business Information

Please charge my Mastercard/Visa/Amex account

With £ Expiry Date

Signature

Name

Job Title

Address

Postcode

Tel: Country

Table with 2 columns: Subscription Rates, Price. Includes UK 1 year (£32), UK 2 years (£58), Student rate (£21), Airmail, Europe 1 year (£46), Europe 2 years (£83), Rest of the world 1 year (£56), Rest of the world 2 years (£101), Surface mail 1 year (£37).

Post to:
ELECTRONICS WORLD
P.O. Box 302
Haywards Heath,
West Sussex RH16 3DH UK.

CREDIT CARD HOTLINE
Tel: +44 01444 445566
Fax: +44 01444 445447

Please tick here if you do not wish to receive direct marketing-promotion from other companies

MICROWAVE table listing various microwave components like Transmitter Control VML, Digital Microwave, HP X 352A, etc.

GOOD SELECTION OF 18-20 GHz COAXIAL SWITCHES IN STOCK: £65.00 EACH table listing various coaxial switches and their prices.

OSCILLOSCOPES table listing various oscilloscope models and their prices.

SIGNAL GENERATORS table listing various signal generator models and their prices.

SIGNAL ANALYZERS table listing various signal analyzer models and their prices.

MISCELLANEOUS table listing various miscellaneous electronic components and their prices.

PLOTTERS/RECORDERS table listing various plotter and recorder models and their prices.

AERIAL FACILITIES EQUIPMENT: Receiver Splitter Amplifier, Type RSA-460-4M, Price: £250.00, Bandpass Duplexer, Type BPD-453-460-6N, Price: £300.00, Transmitter Cavity Resonator, Type SC-450-2N, Price: £190.00, Transmitter Cavity Resonator, Type SG-450-2N c/w DT-453-2NV, Price: £190.00

DATA/TELECOMS table listing various data and telecom equipment models and their prices.

Table listing various electronic components and their prices, including diodes, capacitors, and other parts.

Table listing various electronic components and their prices, including diodes, capacitors, and other parts.

PYE CHARGERS TYPE BC21C NEW & BOXED: £25.00, MOTOROLA BATTERY CHARGER TYPE NTN4922A, GOOD CONDITION: £85.00, FARNELL MP30-80, 1KW, 30V, 80A AUTO RANGING POWER SUPPLY: £500.00

Table listing various electronic components and their prices, including diodes, capacitors, and other parts.

Table listing various electronic components and their prices, including diodes, capacitors, and other parts.

Table listing various electronic components and their prices, including diodes, capacitors, and other parts.

Table listing various electronic components and their prices, including diodes, capacitors, and other parts.

Table listing various electronic components and their prices, including diodes, capacitors, and other parts.

Table listing various electronic components and their prices, including diodes, capacitors, and other parts.

Table listing various electronic components and their prices, including diodes, capacitors, and other parts.

Table listing various electronic components and their prices, including diodes, capacitors, and other parts.

RACAL TACTICOM VHF TRANSMITTER/RECEIVER WITH ANTI-JAMMING AND INTEGRAL SPEECH FUNCTIONS (JAGUAR VELOCITY RADIO VR0316HE-HG) COMPLETE SYSTEM PRICE: £2,500.00

TELFORD ELECTRONICS
Old Officers Mess, Hoo Farm, Humbers Lane,
Horton, Telford, Shropshire TF6 6DJ, UK
Phone: (00 44) 01952 605451 Fax: (00 44) 01952 677978
e-mail: telfordelectronics@telford2.demon.co.uk
Carriage: £10+VAT @17.5% to be added to all UK orders
Overseas orders welcome - Please call
+++ Merry Christmas to all our Customers, +++
++++ Old and New +++++

CIRCUIT IDEAS

Over £600 for a circuit idea?

New awards scheme for circuit ideas

- Every circuit idea published in *Electronics World* receives £35.
- The pick of the month circuit idea receives a Pico Technology ADC42 – worth over £90 – in addition to £35.
- Once every six months, Pico Technology and *Electronics World* will select the best circuit idea published during the period and award the winner a Pico Technology ADC200-50 – worth £586.

How to submit your ideas

The best ideas are the ones that save readers time or money, or that solve a problem in a better or more elegant way than existing circuits. We will also consider the odd solution looking for a problem – if it has a degree of ingenuity.

Your submission will be judged on its originality. This means that the idea should certainly not have been published before. Useful modifications to existing circuits will be considered though – provided that they are original.

Don't forget to say why you think your idea is worthy. We can accept anything from clear hand writing and hand-draw circuits on the back of an envelope. Type written text is better. But it helps us if the idea is on disk in a popular pc or Mac format. Include an ascii file and hard-copy drawing as a safety net and please label the disk with as much information as you can.

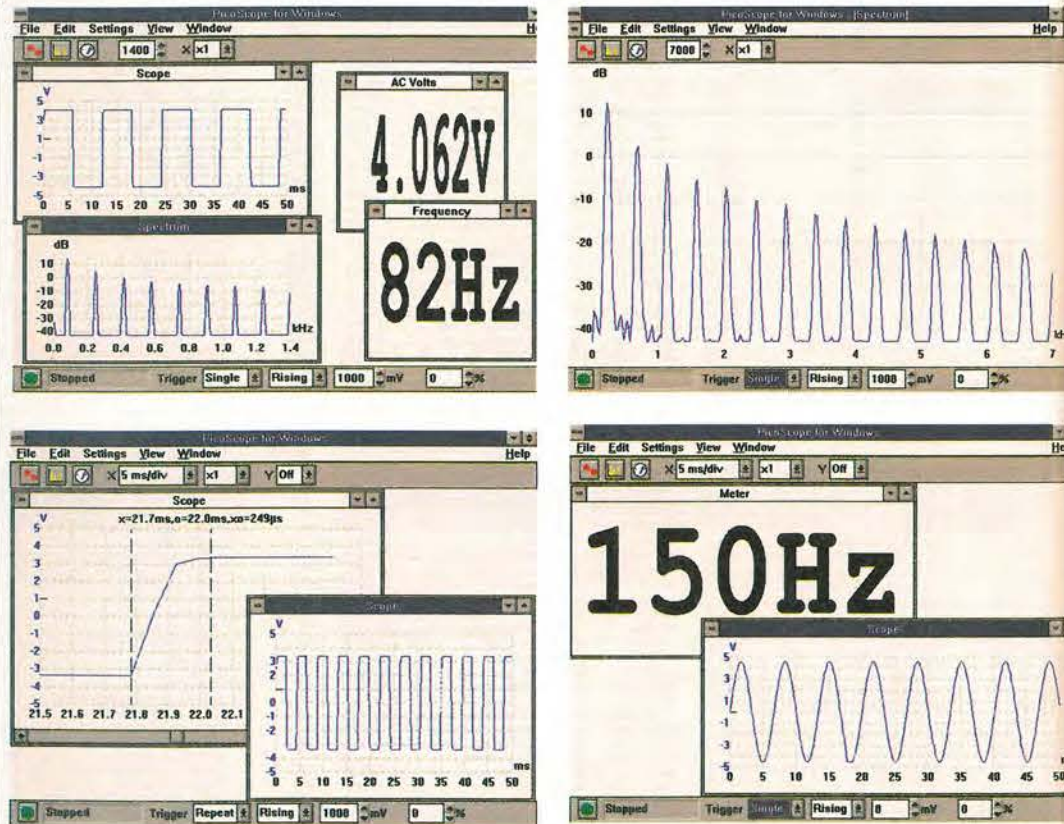

Turn your PC into a high-performance virtual instrument in return for a circuit idea.

The ADC200-50 is a dual-channel 50MHz digital storage oscilloscope, a 25MHz spectrum analyser and a multimeter. Interfacing to a pc via its parallel port, ADC200-50 also offers non-volatile storage and hard-copy facilities. Windows and DOS virtual instrument software is included.

ADC42 is a low-cost, high-resolution a-to-d converter sampling to 12 bits at 20ksample/s. This single-channel converter benefits from all the instrumentation features of the ADC200-50.

Trickier keypad lock

While small keypad locks are simple and quick to make, their four-digit code offers limited security; it would be possible, if tedious, to plod through them all. This circuit puts a further barrier in the way in that two buttons must be pressed at the same time, and the hopeful tealeaf does not even know to do that, let alone which two. In the circuit shown, the entry code is 4, 1, 7, 92; the pair of buttons are best well separated to avoid accidental operation.

Keys on the pad I used had one side common. Cutting one track and wiring the switch in series gave the circuit shown. An LS7220 does the job, but others would perform in the same way.

Neville Frewin
Fontainebleau
South Africa
(A31)

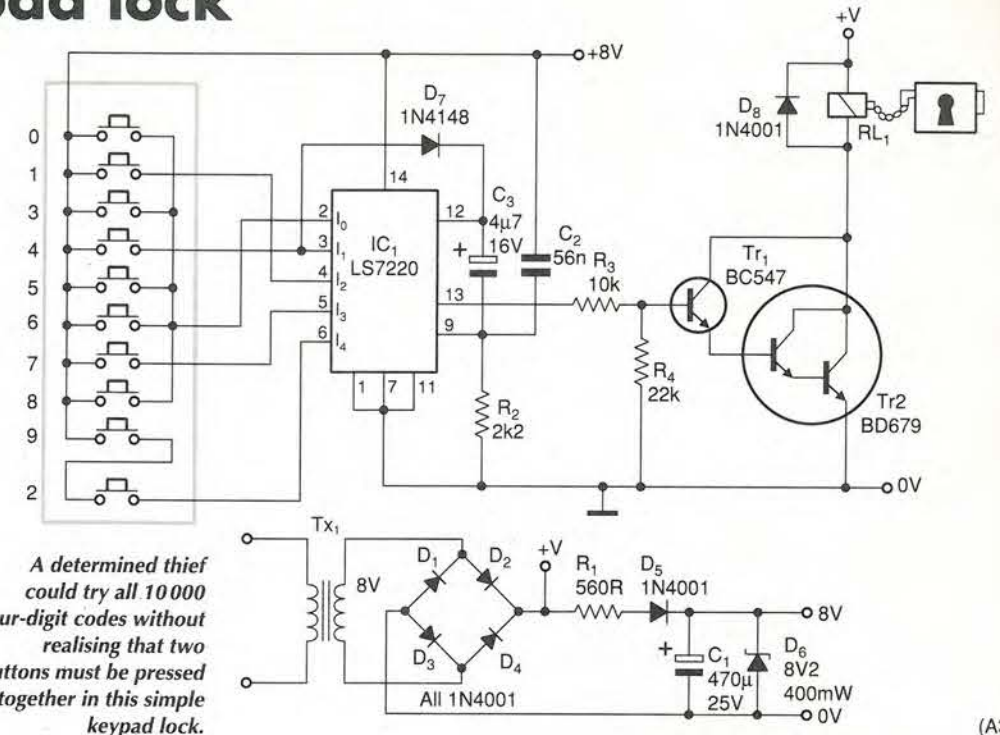

A determined thief could try all 10000 four-digit codes without realising that two buttons must be pressed together in this simple keypad lock.

5MHz triangle generator

Generating linear, high-frequency triangular waves has its problems. Although there are dedicated ics, some are fairly expensive and others put out a linear waveform, but at the expense of bandwidth. This circuit avoids these problems.

Instead of the usual op-amp RC integrator, the constant charging current is provided by a pair of current mirrors contained in a TPQ6502 array to give a good match. In response to the output waveform, an LM311 comparator switches the current mirrors on and off via Tr_{1,2}, slopes being independently determined by the values of R_{3,4}, which may be replaced by variable resistors. Frequency is

set by R₇ which may also be made variable, and R₉ adjusts the dc level of the output.

Board layout demands care: supply lines to Tr_{1,2} and those to the comparator must all be kept separate from the supply to the mirrors. A single ground and good decoupling are essential for a good performance at high frequencies.

Higher frequencies than 5MHz are possible, while retaining good linearity, if the LM311 is replaced by a faster type.

K P Cummings
University of Nottingham
(A30)

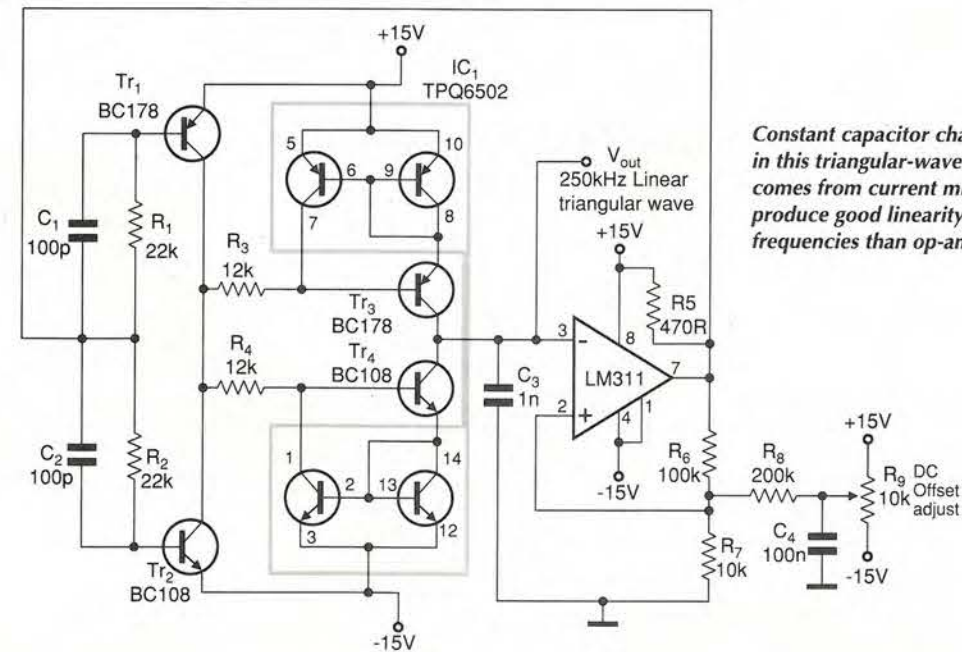

Constant capacitor charging current in this triangular-wave generator comes from current mirrors, which produce good linearity at higher frequencies than op-amp integrators.

**ADC-42
WINNER**

Analogue frequency doubler

Two comparators may be connected to either a difference amplifier or to a summer to produce a frequency doubler or a variable-width output pulse. Basic comparator operation in Fig. 1 shows the effect of reversing inputs, the arrangement in Fig. 2 producing, in response to a sawtooth input waveform, positive pulses at pins 1 and 7, the width of which depend on the rectangular V_{ref1} , V_{ref2} waveforms and V_{in} . Subtracting one from the other in the LM301 difference amplifier gives the output shown in Fig. 3.

Alternatively, connecting the comparator outputs to a summer combines the comparator outputs to give a pulse proportional to the input and reference voltages, variable from zero to 100%. Output spectrum is variable in this way, so that given harmonics may be eliminated or created by varying the reference voltages.

Kamil Kraus
Rokycany
Czech Republic
(A40a)

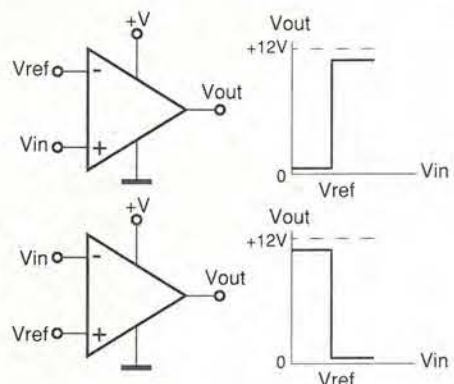

Fig. 1. Comparator output with rectangular wave applied to either of the inputs.

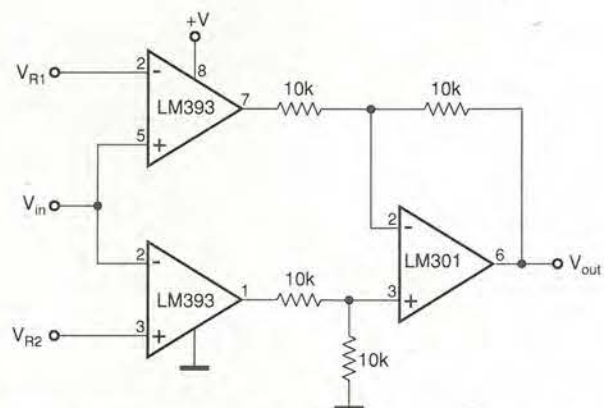

Fig. 2. Full circuit of frequency doubler. Replacing difference amplifier with summing amplifier produces a pulse variable in width from zero to 100% of the input.

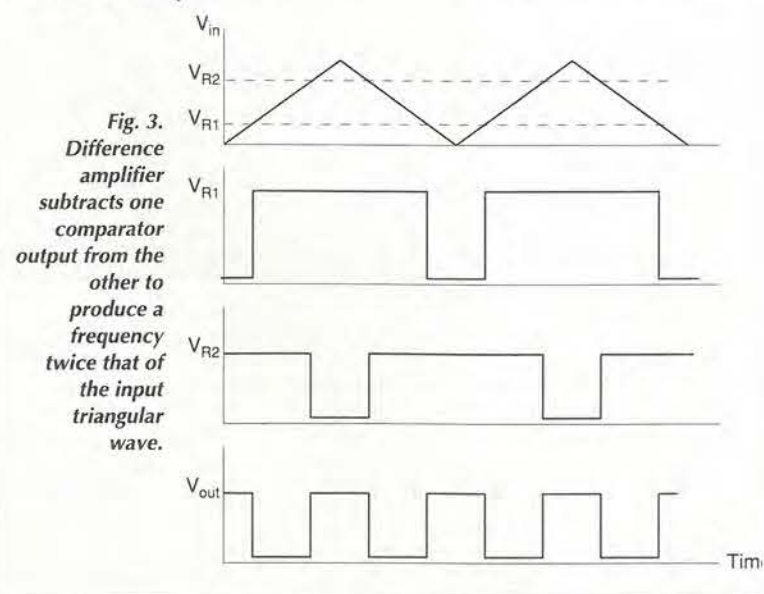

Fig. 3. Difference amplifier subtracts one comparator output from the other to produce a frequency twice that of the input triangular wave.

Input signal	Comment	LEDs			
		Red	Green	Orange	Yellow
High	High	On	Off	N/A	N/A
Low	Low	Off	On	N/A	N/A
Transition low to high	Transition low to high	On	Off	On	Off
Transition high to low	Transition high to low	Off	On	Off	On
Single pulse	Single pulse	Off	On	On	On
Single pulse	Single pulse	On	Off	On	On
Pulsing	Pulsing	Blinking	Blinking	On	On

Fast pulse capture/analysis

Needing to detect the presence of a single 1µs pulse, which was too fast for a logic analyser to see, I made the circuit shown here, which will show the presence of a pulse down to 10ns in width and also indicates the activity on a signal line.

Indication is by a series of leds. Logic high at the input causes the red led to illuminate, a low lighting the green one. Inverted and non-inverted versions of the input form clock signals for the two edge-triggered flip-flops; a low-to-high transition triggers the Q output at pin 5 to light the orange led, a high-to-low triggering the pin 9 Q output to illuminate the yellow led; a single pulse turns on both orange and yellow leds, the red and green indicating whether it is negative or positive going, as shown by the table.

Switch S_1 resets both flip-flops. Continuous activity on the line causes the red and green leds to flash.

Ken Yang
La Jolla
California
USA
A43

Using only two ics, this logic-level indicator will capture a single pulse of around 10ns in width and analyses the state of a signal line.

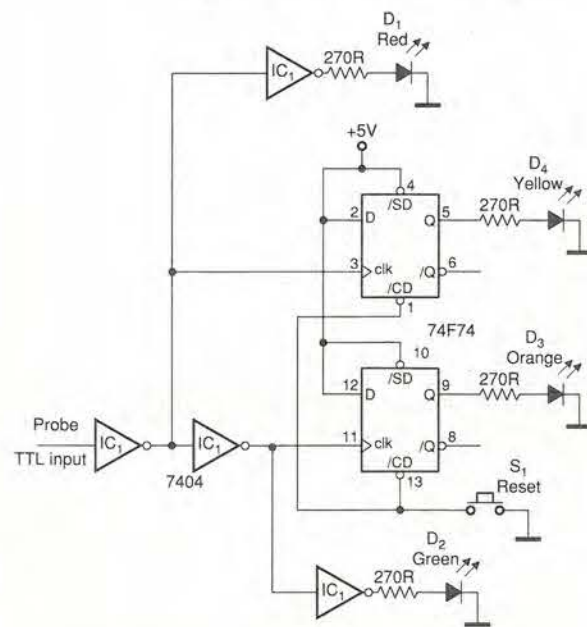

Micro Video Cameras

Direct from the sole authorised importer

* **Wire up in minutes.** Only three connections – ground, +12V and composite video output for feeding straight to your Scart connector or monitor input.

* **Tiny and lightweight.** Ideal for surveillance and security, the A-721 Micro-video camera pcb measures just 32 by 32mm. The complete camera weighs only 30g.

* **Integral lens.** 3.6mm 5-element lens, interchangeable with our wide range of replacement lenses.

* **Low cost.** The A-721 Micro-video camera costs just £65 – including VAT.

* **Incredible low light performance.** The A-721 has a light sensitivity of < 0.1 lux (normal light).

* **Reliable.** The A-721 is manufactured using state-of-the-art equipment and under strict quality control.

* **Fast delivery mail order.** We endeavour to dispatch all orders same day.

* **12 months guarantee.**

And more ... This is just a small sample of the huge range of Camera and Video Surveillance equipment we stock.

Ring 0115 986 4902 now,
or fax us on 0115 986 4667

* Prices include VAT but exclude carriage at £6.00 UK mainland



The A-721-S Micro-video camera with lens outputs composite video and costs just £65*/3 for £150



Priced at £125*/3 for £300, the PC-CAM colour camera is ideal for video conferencing and PC video digitising.



With the same performance as the A-721-S the A-721-P is optimised for use as a pin-hole camera and costs just £65*

NEW FULL COLOUR CATALOGUE AVAILABLE NOW

*** Free Catalogue ***

Send an A4 envelope with 1st class stamp marked 'Camera catalogue' to receive comprehensive data on our entire range of cameras and video surveillance equipment.

Anchor Supplies Ltd.

Callers are welcome at our massive showrooms on weekdays from 9am until 6pm and on Saturdays from 8am to 4pm. Anchor Supplies Ltd is at the Cattle Market in Nottingham. NG2 3GY (opposite Notts. County FC). Unlimited parking adjacent. Visit our web site: <http://www.anchor-supplies.ltd.uk> or send email to: sales@anchor-supplies.ltd.uk

CIRCLE NO. 134 ON REPLY CARD

TOROIDAL TRANSFORMERS

High Quality Low Prices

In addition to our standard range we will be pleased to quote for your special requirements.



PRICE LIST

VA	Mail Order	Quantity Price Excluding VAT & Carriage				
		2+	10+	25+	50+	100+
15	14.59	10.21	7.69	5.69	5.52	5.35
30	16.04	11.23	8.45	6.25	6.06	5.89
50	17.83	12.48	9.40	6.95	6.74	6.53
60	18.02	12.61	9.49	7.02	6.82	6.61
80	17.98	12.60	9.49	7.02	6.81	6.60
100	21.07	14.74	11.11	8.21	7.96	7.72
120	21.54	15.08	11.35	8.39	8.15	7.89
150	25.98	18.19	13.70	10.12	9.82	9.53
160	23.83	16.68	12.56	9.28	9.00	8.73
225	30.10	21.07	15.87	11.73	11.39	11.04
300	34.32	24.02	18.09	13.38	12.98	12.58
400	46.19	32.32	24.35	17.99	17.47	16.94
500	50.48	35.34	26.61	19.67	19.09	18.51
625	53.09	41.36	31.14	23.02	21.24	20.57
750	58.39	44.23	33.30	24.62	23.89	23.17
1000	78.80	55.16	41.54	30.70	29.80	28.89
1200	82.45	57.72	43.46	32.12	31.17	30.23
1500	105.10	73.63	55.40	40.94	39.74	38.53
2000	114.45	96.13	72.39	53.51	51.93	50.36
2500	163.04	114.13	85.94	63.51	61.64	59.79

These prices are for 240volt primary and two equal secondaries with 8" colour coded fly leads.

Each transformer is supplied with a mounting kit (steel dish washer pads, nut and bolt)

Mail order prices include vat and postage.

Please do not hesitate to telephone or write with your particular requirements.

Airlink Sales Co

16 Knight Street, Sawbridgeworth, Herts CM21 9AT
Tel: 01279 600139 Fax: 01279 726379

CIRCLE NO. 135 ON REPLY CARD

ADVANCED ACTIVE AERIAL



The aerial consists of an outdoor head unit with a control and power unit and offers exceptional intermodulation performance: SOIP +90dBm, TOIP +55dBm. For the first time this permits full use of an active system around the lf and mf broadcast bands where products found are only those radiated from transmitter sites.

- General purpose professional reception 4kHz-30MHz.
- -10dB gain, field strength in volts/metre to 50 Ohms.
- Preselector and attenuators allow full dynamic range to be realised on practical receivers and spectrum analysers.
- Noise - 150dBm in 1Hz. Clipping 16 volts/metre. Also 50 volts/metre version.

- ★ Broadcast Monitor Receiver 150kHz-30MHz.
- ★ Stabilizer and Frequency Shifters for Howl Reduction
- ★ Stereo Variable Emphasis Limiter 3
- ★ 10-Outlet Distribution Amplifier 4
- ★ PPM10 In-vision PPM and chart recorder
- ★ Twin PPM Rack and Box Units.
- ★ PPM5 hybrid, PPM9 microprocessor and PPM8 IEC/DIN -50/+6dB drives and meter movements
- ★ Broadcast Stereo Coders

SURREY ELECTRONICS LTD

The Forge, Lucks Green, Cranleigh GU6 7BG
Telephone: 01483 275997 Fax: 01483: 276477
s.e@ndirect.co.uk www.ndirect.co.uk/~se/se.html

Precise mains voltage measurement

Having a need to display high-resolution mains voltage readings in the 190-250V ac range at the input of an uninterruptible power supply which has an 8-bit a-to-d converter, I had to convert the range into a 0.5-4.5V dc swing, that being the input range of the converter. In addition, I needed overvoltage and undervoltage warnings on a seven-segment display.

Ups output is transformed, full-wave rectified (the 6-0-6V transformer was handy) and passed through two second-order 15Hz filters. Output is adjusted to give 7V dc for a 190V ac input, the swing being 7-9.22V dc for the full 190-250 ac mains excursion.

This goes to a difference amplifier, of which the other input is 6.8V, so that the 0.2-2.4V swing, having been amplified by a factor of two, is within the limits of the a-to-d converter at B.

An out-of-range signal results from the action of the window comparator, which takes its input from B and has comparison levels of 4.9V and 0.4V, producing a logic 1 at the output when the input is within range.

Jayant Kathé
Bombay
India
(A33)

High-resolution mains voltage measurement in the 190-250V ac range, requiring a 0-5V dc output to an 8-bit a-to-d converter. Rest of the circuit is an in-range/out-of-range warning.

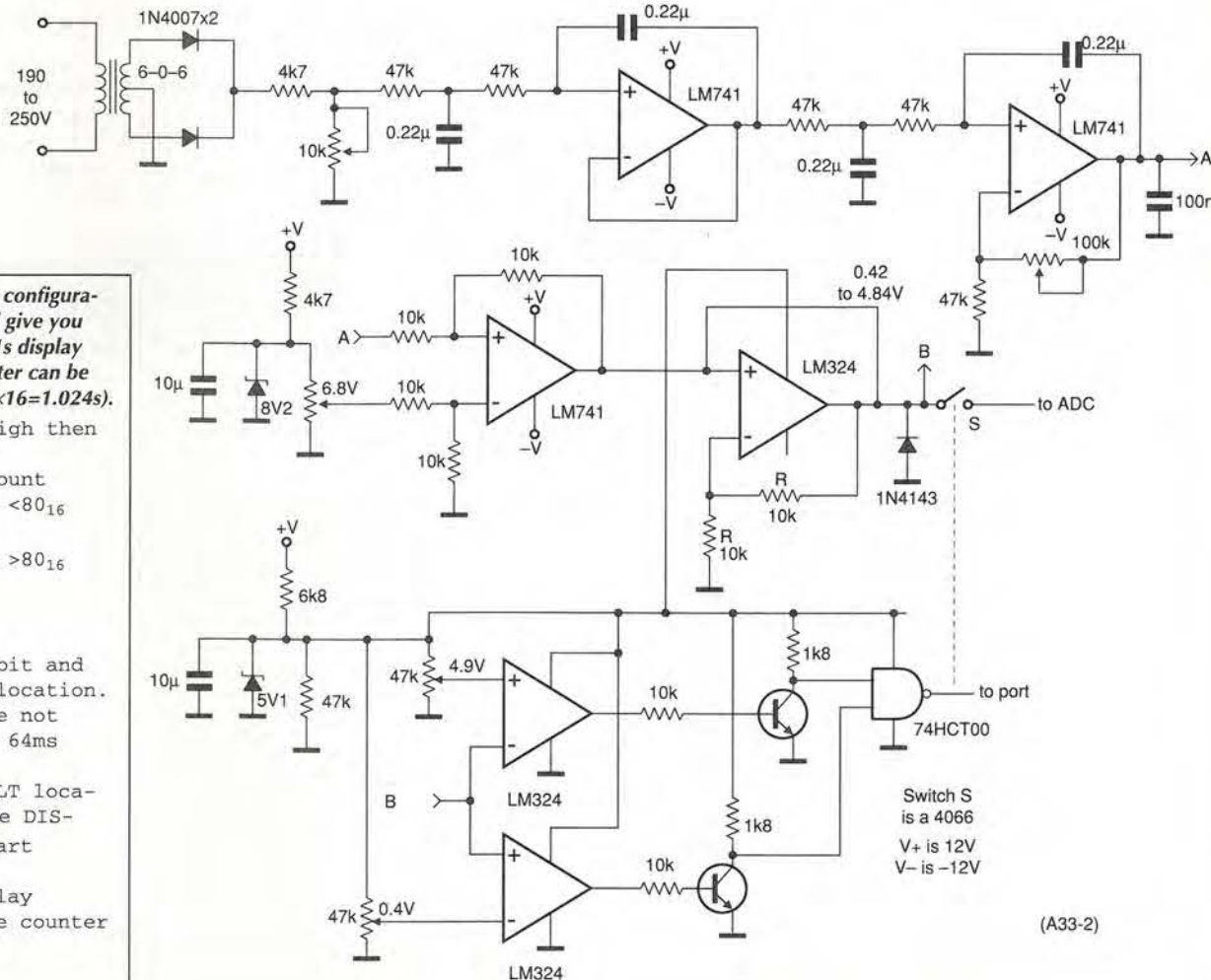
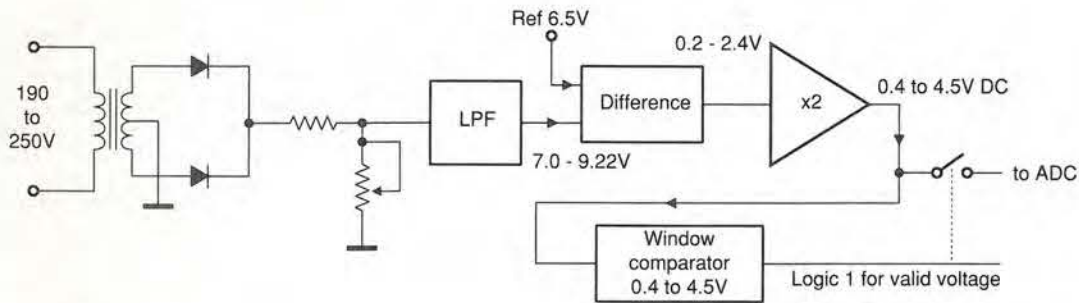

(A33-2)

Software depends on the configuration, but this flow should give you some ideas. Assuming a 1s display update, an a-to-d converter can be taken every 64ms (64ms x 16 = 1.024s).

- 1 If port pin is high then goto 6
- 2 Get stored ADC count
- 3 If I/P ADC count < 80₁₆ Display
- 4 If I/P ADC count > 80₁₆ Display
- 5 goto 1
- 6 Get ADC count
- 7 Right shift one bit and ADD to MAINS-VOLT location.
- 8 If 16 samples are not over than wait for 64ms goto 1.
- 9 Add the MAINS-VOLT location₁₆ value to the DISPLAY-DATA-TABLE start address.
- 10 Update the display
- 11 Reset the sample counter to 0 goto 1

HOW DOES YOUR EQUIPMENT MEASURE UP? ???

PHILIPS PM3217 (This is a proper scope) Dual Trace 50MHz Delay Sweep Incl 2 Probes £400

HC3502 Dual Trace 20MHz 5mV/20V/div; 0.2 µ Secs - 0.5 Sec/Div. X-Y; X5 magnifier; TV Sync etc. Hardly Used £150 Un-used £200

THE CLASSIC TEKTRONIX 400 SERIES

488 Digital Storage Dual Trace 100MHz Delay £650
486 Analogue Storage Dual Trace 100MHz Delay £395
475 Dual Trace 200MHz Delay Sweep £560
465 Dual Trace 100MHz Delay Sweep £400

FLUKE PM3002 2+2ch 100MHz Delay TB Cursors £1200
PHILIPS PM3286A Dual Trace 60MHz Dual TB Delay Cursors IEEE £1750
TEKTRONIX 2456A 4 Trace 350MHz Delay Cursors etc £2500
TEKTRONIX 1546S Dual Trace 100MHz Delay Cursors £900
TEKTRONIX 2215 Dual Trace 60MHz Delay Sweep £400
PHILIPS 3855 2+1 Ch 50MHz Dual TB Delay £475
PHILIPS PM187 Dual Trace 50MHz SCOP/EMETER Dig Storage £500
GOLD 051100 Dual Trace 30MHz £200 With Delay £240
GOLD 05300 Dual Trace 20MHz £200

AND REMEMBER ALL OUR EQUIPMENT IS TESTED PROPERLY!

STEWART of READING

110 WYKEHAM ROAD, READING, BERKS. RG6 1PL
Telephone: (0118) 9268041. Fax: (0118) 9351696
Callers Welcome 9am-5.30pm Monday to Friday (other times by arrangement)

SPECTRUM ANALYSERS

N.P. 8555A 0.01-220GHz £3500
N.P. 8590A 10MHz-1.8GHz 75 ohm £2750
ALITEN 727 0.001-20GHz £1500
N.P. 182 with 8559A 0.01-21GHz £3000
N.P. 182 with 8558B 100kHz-1500MHz from £1500
N.P. 3582A Dual Channel 25kHz £2000
N.P. 141T with 8555A & 8552B 10MHz-18GHz £1500

Other 141T Systems available

MARCONI 2018A Syn AM/FM Signal Gen 80kHz-1040MHz £1800
MARCONI 2019 Syn AM/FM Signal Gen 80kHz-1040MHz £1500
MARCONI 2018 Syn AM/FM Signal Gen 80kHz-520MHz £800
MARCONI 2017 AM/FM Signal Gen 10kHz-1024MHz £1750

FARNELL SS0520 Syn AM/FM Signal Gen 10kHz-520MHz £325
FARNELL PS0520 Syn AM/FM Signal Gen 10kHz-520MHz Portable £450
MARCONI 5311 Programmable Sweep 10MHz-20GHz £4500
MARCONI 3025A AM/FM Signal Gen 10kHz-1GHz £2000
N.P. 8555A Syn Signal Gen 0.1-900MHz £1500
N.P. 8640B Phase-Locked Syn Sig Gen 500kHz-512MHz £750
N.P. 8640B AM/FM Syn Sig Gen 500kHz-1024MHz £850
PHILIPS PM153 Programmable Syn Func Gen 0.1MHz-50MHz £1500
PHILIPS PM152 Programmable Syn Func Gen 0.1MHz-20MHz £1000
N.P. 3325A Syn Function Gen 2MHz £1250
PHILIPS PM134 Sweep Func Gen 0.001Hz-20MHz Sine/Sq/Tri etc £400
PHILIPS PM132 Sweep Func Gen 0.1Hz-2MHz Sine/Sq/Tri etc £250

MARCONI TF2370-110MHz £700-£1000
MARCONI TF2370 with TF2373 30Hz-1.25GHz £1600
N.P. 8620C Sweep osc with 8620B 2-18GHz £1750
N.P. 8620C Sweep osc with 8622B 0.01-2.4GHz £1750
MARCONI TF2015 AM/FM Sig Generator 10-520MHz £150
FARNELL DSG-2 Syn Osc 0.001Hz-105.99Hz Sine/Sq/Sweep/IEEE200 £150
GOLD J3B Sine/Sq Oscillator 10Hz-100kHz £150
FARNELL LFI Sine/Square Oscillator 10MHz-1MHz £75
N.P. 8150A Programmable Precision Pulse Gen 50MHz £350
MARCONI 2510 True RMS Voltmeter GPIB £500
N.P. 3455A 6 1/2 digit Multimeter £700
DATRON 1061A 1061A 6 1/2 digit True RMS with IEEE £800
SOLARTRON 7081 7 1/2 digit Multimeter £1600
EIP 371 Source Locking Microwave Counter 20Hz-18GHz £1500
N.P. 5342A Frequency Counter 10Hz-24GHz £1750
MARCONI 2440 Frequency Counter 10Hz-20GHz IEEE £1750
MARCONI 2437 Universal Counter/Timer DC-100MHz Un-used £125
MARCONI 2430A Frequency Counter 10Hz-80MHz Un-used £95
N.P. 4275A Multi Frequency LCR Meter £3000
N.P. 4261A LCR Meter £1250
RACAL 9343M LCR Databridge IEEE £250
MARCONI 2305 Modulation Meter 500kHz-2GHz £2250
RACAL 9009 Automatic Mod Meter 30MHz-1.5GHz £250
SAYBOSA 252 Automatic Modulation Meter £150
FARNELL AP10030 PSU 0-100V; 0-30A Autorange £1000
FARNELL H6025 0-60V; 0-25A PSU £400
FARNELL TSV70M2 70V SA/35V 10A PSU £200
THURLEY TSX1820 Precision PSU 18V 20A £275
THURLEY P320 32V 2A Twice GPIB Digital £450
THURLEY PL320 32V 2A Digital PSU with GPIB £150
RACAL 9104 RF Power Meter 1MHz-1GHz 10mW-300W £325
MARCONI 2167 RF Amplifier 50kHz-80MHz 10W 47dB Gain £150
HUNTRON TRACKER Model 1000 in Carrying Case £125
STABLOCK 4021 Radio Test Set £700

BIRD 43 ELEMENTS

Types 5A, 10A, 100A, 5B, 10B, 100B, 5C, 25C, 250C, 50C, 250, 500, 1000. £25 each 100Hz, 250Hz, 1000Hz, £35 each 1000P £85

USED EQUIPMENT - GUARANTEED. MANUALS SUPPLIED.

This is a VERY SMALL SAMPLE OF STOCK. SAE or Telephone for lists. Please check availability before ordering. CARRIAGE all units £16. VAT to be added to Total of Goods and Carriage.

STEREO AUDIO BALANCE TO UNBALANCED CONVERTOR Un-used £20

AT STEWART OF READING THERE'S ALWAYS ROOM FOR IMPROVEMENT!

LOOK! BRAND NEW OSCILLOSCOPES! NEVER USED!! LIMITED STOCK!!!

DMS 3850A Digital Storage/DMM Handheld LCD display 2 Channel 50MS/S. Auto Range. 4 digit DMM/Capacitance/Frequency Counter. Battery Operation or external 7.5-9VDC ie. AC Adaptor (Not supplied). RS232 Comes in Black Carrying Pouch complete with 2 scope probes; DMM leads; manual. New Boxed For Only £400

DTV 100 3 Channel 100MHZ Sweep Delay etc: £425
DTV 60 3 Channel 60MHZ Sweep Delay etc: £375
DTV 20 Dual Trace 20 MHZ: £200
All unused, boxed with 2 probes & manual

DTA 20/40/60 Dual Trace with Alt Magnification; TV Trig etc. etc. Lots of Specification.
DTA20 Dual Trace 20MHz: £225
DTA40 Dual Trace 40MHz - 12KV EHT: £300
DTA60 Dual Trace 60MHz - 12KV EHT: £375
All unused & boxed supplied with 2 probes & Manual

CIRCLE NO. 137 ON REPLY CARD

COMPONENTS & SYSTEMS FROM IOSIS

System Components from ISO9001 Source
Half Size Single Board Computers
386SX to Pentium with ISA and PC/104 Bus
2 Serial Ports, IDE, FDD & Printer Port
Flash/ROM Disc, Cache, SVGA CRT/Flat Panel Controller
PC/104 Modules
386 & 486 CPUs, Solid State Disc, Isolated RS232/485
VGA CRT/Flat Panel Display & SVGA Controllers
PCMCIA types I, II & III
Fast SCSI, Ethernet, Fax/Modem
System Enclosures with Passive Backplanes
System Integration and Support
All-In-One Standard Motherboards & Cases
486/586 to 200MHz Pentium

4 Sommersville Rd, St Andrews
Bristol, BS7 9AA.
Tel 0117 924 9231
Fax 0117 924 9233
Email: sales@iosis.co.uk

Details on our website <http://www iosis.co.uk>

CIRCLE NO. 138 ON REPLY CARD

PIC listing on disk

Because the assembly language routine for the PIC would have taken up around four magazine pages we were unable to publish it. If you want a copy of this fully-annotated listing and the Excel spreadsheet shown, on 3.5in disk, send £10 to cover administration and copying to Electronics World's editorial offices, Quadrant House, The Quadrant, Sutton, Surrey SM2 5AS, with a clear note of what you are requesting and your address.

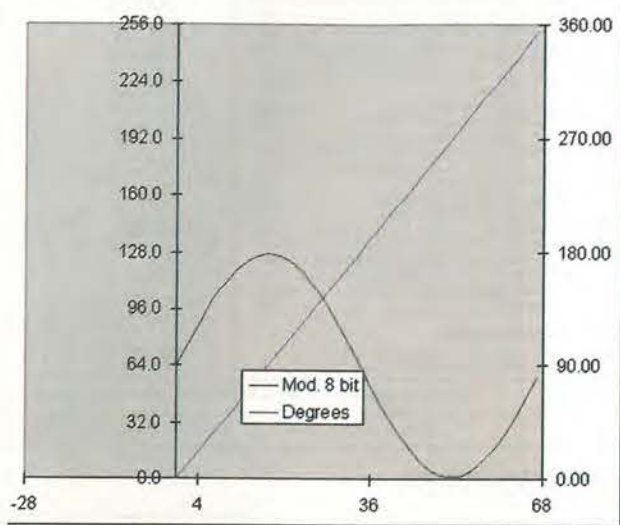

Begin and end of the Excel file, below, used to determine values in the PIC program illustrates how a spreadsheet can break the back of a digital design.

50/60Hz sine oscillator

A Wien-bridge oscillator is the obvious type of circuit to use for a vlf oscillator, providing a low-power, stable output while using low-voltage, low-current supplies – particularly if op-amps providing rail-to-rail output are used. However, the circuit shown offers good initial accuracy and low-frequency drift by virtue of the crystal clock oscillator, and amplitude stability. No adjustments or high-value precision capacitors are needed.

The R₂R ladder is driven by the logic-level i/o lines from a PIC microcontroller, data coming from a software look-up table. Resolution is to seven bits and amplitude 0.02V-2.61V. A 3-bit counter output is also available. High ladder resistance provides a light load for the logic outputs, although they are capable of much more current. The circuit takes 52µA as shown, and may be reduced by scaling up resistor values at the risk of increased emi.

At a standard clock frequency of 32.768kHz, output frequencies are 49.951Hz and 60.235Hz; to make these exact, the clock should be 32kHz. You can do this, at the expense of a higher quiescent current and a greater number of components, by using a 4.096MHz crystal and dividing it in, say, a 74HC4060 binary counter/divider to give exactly 32kHz.

MAX951 contains an op-amp, a comparator and band-gap reference, the op-amp and reference providing a 2.63V supply for the microcontroller and the comparator converting the microcontroller's msb to a 'phase' signal that goes high during positive half-cycles of the output.

As well as the look-up table for both frequencies, the

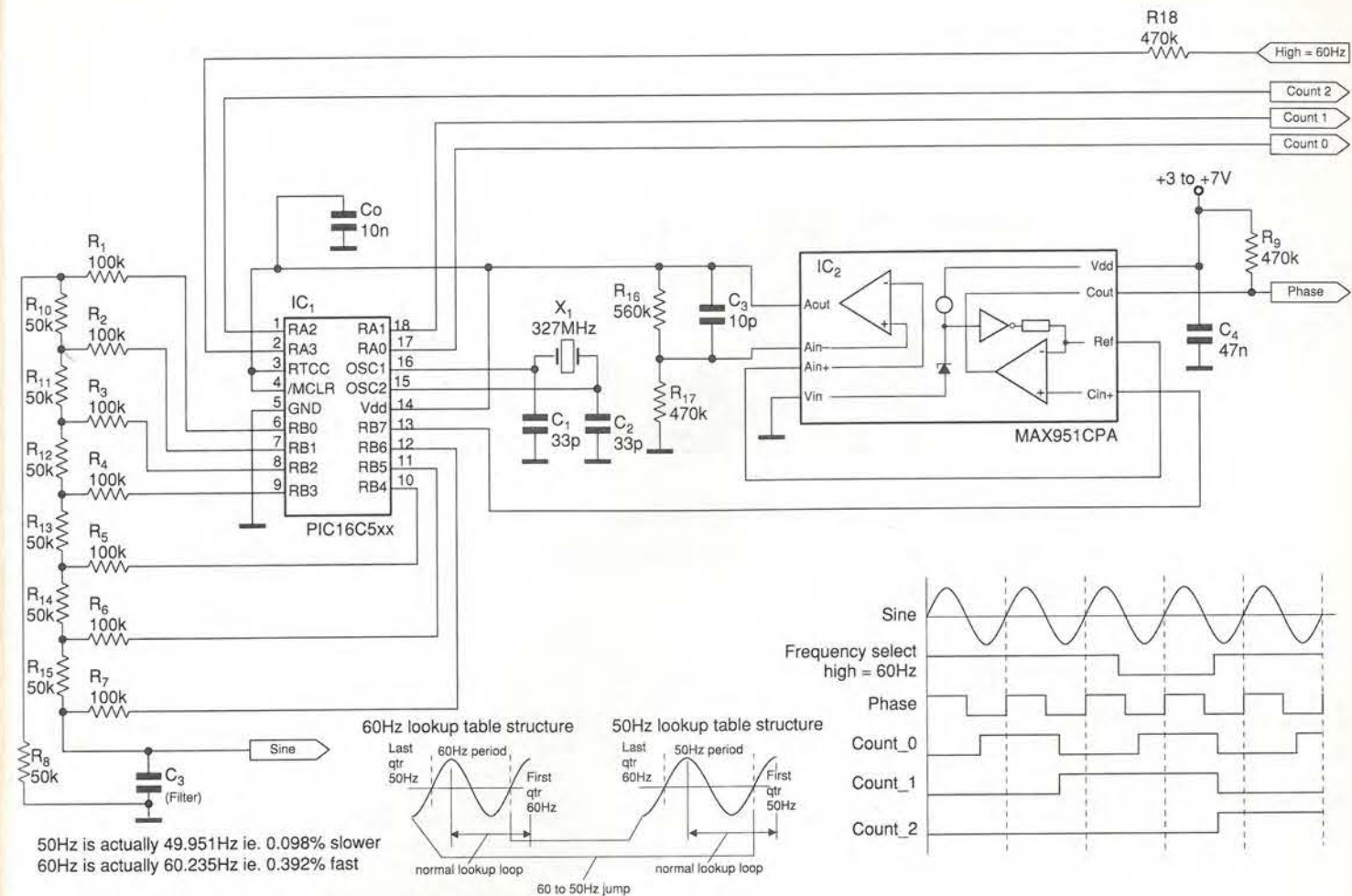

50Hz is actually 49.951Hz ie. 0.098% slower
60Hz is actually 60.235Hz ie. 0.392% fast

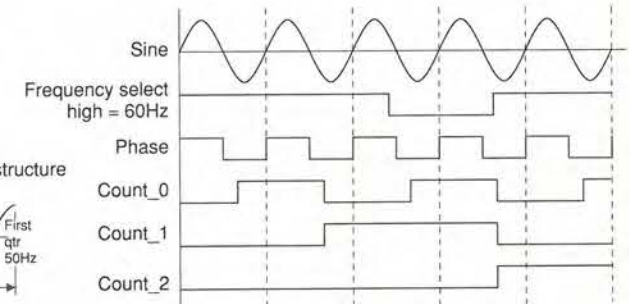
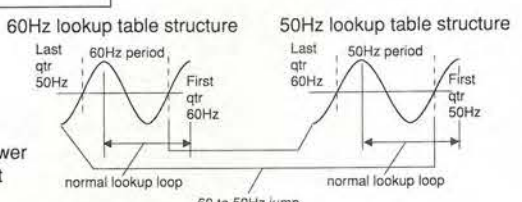

Microcontroller drives resistive ladder from a look-up table to produce an accurate sine output at selectable 50Hz or 60Hz frequencies, with a 3-bit period timer output and a sync. signal.

software produces a continuous wave train by repeatedly jumping from the end of the table to the start at the positive peak, ensuring a smooth 50-60Hz change by having a sequence of the last quarter-period of the other frequency. Changes occur at rising zero crossings, as happens in frequency-shift keying.

Tim Herklots
Maxim Integrated Products
Reading
Berkshire
(A42)

File	Edit	View	Insert	Format	Tools	Data	Window	Help
1	Steps:	68.00						
2	2pi/Steps:	0.09						
3	Address	Degrees	Angle	Mod. 8 bit	Rounded	PIC Instruction		
4	0	0.00	0.000	64.0	64	movlw 0x	C0	0 at 60Hz is 64.0 rounded to 64 Q movwf port_b ;
5	1	5.29	0.092	69.8	70	movlw 0x	C6	1 at 60Hz is 69.8 rounded to 70 Q movwf port_b ;
6	2	10.59	0.184	75.6	76	movlw 0x	CC	2 at 60Hz is 75.6 rounded to 76 Q movwf port_b ;
7	3	15.88	0.274	81.2	81	movlw 0x	D1	3 at 60Hz is 81.2 rounded to 81 Q movwf port_b ;
8	4	21.18	0.361	86.8	87	movlw 0x	D7	4 at 60Hz is 86.8 rounded to 87 Q movwf port_b ;
9	5	26.47	0.446	92.1	92	movlw 0x	DC	5 at 60Hz is 92.1 rounded to 92 Q movwf port_b ;
10	6	31.76	0.526	97.2	97	movlw 0x	E1	6 at 60Hz is 97.2 rounded to 97 Q movwf port_b ;
11	7	37.06	0.603	102.0	102	movlw 0x	E6	7 at 60Hz is 102.0 rounded to 102 Q movwf port_b ;
12	8	42.35	0.674	106.4	106	movlw 0x	EA	8 at 60Hz is 106.4 rounded to 106 Q movwf port_b ;
13	9	47.65	0.739	110.6	111	movlw 0x	EF	9 at 60Hz is 110.6 rounded to 111 Q movwf port_b ;
14	10	52.94	0.798	114.3	114	movlw 0x	F2	10 at 60Hz is 114.3 rounded to 114 Q movwf port_b ;
15	11	58.24	0.850	117.6	118	movlw 0x	F6	11 at 60Hz is 117.6 rounded to 118 Q movwf port_b ;
16	12	63.53	0.895	120.4	120	movlw 0x	F8	12 at 60Hz is 120.4 rounded to 120 Q movwf port_b ;
17	13	68.82	0.932	122.7	123	movlw 0x	FB	13 at 60Hz is 122.7 rounded to 123 Q movwf port_b ;
18	14	74.12	0.962	124.6	125	movlw 0x	FD	14 at 60Hz is 124.6 rounded to 125 Q movwf port_b ;
19	15	79.41	0.983	125.9	126	movlw 0x	FE	15 at 60Hz is 125.9 rounded to 126 Q movwf port_b ;
20	16	84.71	0.996	126.7	127	movlw 0x	FF	16 at 60Hz is 126.7 rounded to 127 Q movwf port_b ;

File	Edit	View	Insert	Format	Tools	Data	Window	Help
1	Steps:	68.00						
2	2pi/Steps:	0.09						
3	Address	Degrees	Angle	Mod. 8 bit	Rounded	PIC Instruction		
4	0	0.00	0.000	64.0	64	movlw 0x	C0	0 at 60Hz is 64.0 rounded to 64 Q movwf port_b ;
5	1	5.29	0.092	69.8	70	movlw 0x	C6	1 at 60Hz is 69.8 rounded to 70 Q movwf port_b ;
6	2	10.59	0.184	75.6	76	movlw 0x	CC	2 at 60Hz is 75.6 rounded to 76 Q movwf port_b ;
7	3	15.88	0.274	81.2	81	movlw 0x	D1	3 at 60Hz is 81.2 rounded to 81 Q movwf port_b ;
8	4	21.18	0.361	86.8	87	movlw 0x	D7	4 at 60Hz is 86.8 rounded to 87 Q movwf port_b ;
9	5	26.47	0.446	92.1	92	movlw 0x	DC	5 at 60Hz is 92.1 rounded to 92 Q movwf port_b ;
10	6	31.76	0.526	97.2	97	movlw 0x	E1	6 at 60Hz is 97.2 rounded to 97 Q movwf port_b ;
11	7	37.06	0.603	102.0	102	movlw 0x	E6	7 at 60Hz is 102.0 rounded to 102 Q movwf port_b ;
12	8	42.35	0.674	106.4	106	movlw 0x	EA	8 at 60Hz is 106.4 rounded to 106 Q movwf port_b ;
13	9	47.65	0.739	110.6	111	movlw 0x	EF	9 at 60Hz is 110.6 rounded to 111 Q movwf port_b ;
14	10	52.94	0.798	114.3	114	movlw 0x	F2	10 at 60Hz is 114.3 rounded to 114 Q movwf port_b ;
15	11	58.24	0.850	117.6	118	movlw 0x	F6	11 at 60Hz is 117.6 rounded to 118 Q movwf port_b ;
16	12	63.53	0.895	120.4	120	movlw 0x	F8	12 at 60Hz is 120.4 rounded to 120 Q movwf port_b ;
17	13	68.82	0.932	122.7	123	movlw 0x	FB	13 at 60Hz is 122.7 rounded to 123 Q movwf port_b ;
18	14	74.12	0.962	124.6	125	movlw 0x	FD	14 at 60Hz is 124.6 rounded to 125 Q movwf port_b ;
19	15	79.41	0.983	125.9	126	movlw 0x	FE	15 at 60Hz is 125.9 rounded to 126 Q movwf port_b ;
20	16	84.71	0.996	126.7	127	movlw 0x	FF	16 at 60Hz is 126.7 rounded to 127 Q movwf port_b ;

Lead-acid battery saver

When a lead-acid battery is flattened completely, it is little further use. This circuit, which is small enough to use in a battery pack, prevents such abuse, automatically disconnecting the battery if its voltage drops below 10V. It allows the occasional voltage drop caused by equipment drawing a high inrush current and also automatically connects the battery to a correctly applied charging voltage.

Starting from the condition when the relay is on, the battery voltage appears at the output terminals and the potential divider applies 0.81V to the transistor base, assuming battery voltage is more than 10V, the resulting base current turning it on and maintaining the relay.

Falling battery voltage reduces base current and eventually, at about 9.5V, the transistor turns off and the relay drops out, disconnecting the battery; the same result is brought about by the off button.

Starting from the odd condition, pressing the on button momentarily injects current into the transistor base and turns it on.

Daniel Greenspan
Jerusalem
(A44)

This protective circuit prevents lead-acid batteries completely discharging and is inexpensive and small enough to be used in the battery pack itself.

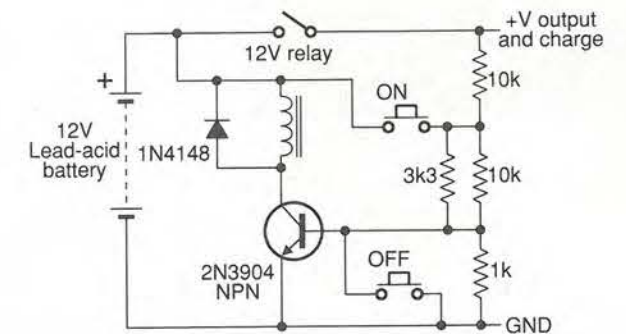

Designer heat sinks

Using two worked examples, Ray Fautley shows how quick and easy it is to determine heat sink size for any transistor or diode using a design table.

Semiconductor devices need to be mounted on metal panels of sufficient size and thermal conductivity to be able to conduct excessive heat away from the junction of the transistor or diode. This is necessary to prevent the temperature of the device's junction from exceeding its maximum rating.

The total thermal path between the device junction and the ambient temperature existing inside the case of the equipment is measured as a thermal resistance. It is referred to as $R_{th(j-amb)}$, or as $\theta_{(j-a)}$. This term that is easy to assess. You only need to know three things.

One is the maximum allowable junction temperature – which for most discrete silicon devices may be assumed to be about 200°C. Secondly you need to know the ambient temperature, which inside electronic equipment is usually about 50°C, and finally you need to know the power dissipated in the semiconductor.

This total thermal path $R_{th(j-amb)}$ comprises three parts,

- The thermal path from device junction to its case, $R_{th(j-c)}$, also called $\theta_{th(j-c)}$ or $R_{th(j-mb)}$.
- The thermal path between the case of the device and the heat-sink to which it is fitted, $R_{th(c-hs)}$, also called $\theta_{th(c-hs)}$.
- The thermal path between the heat-sink and the ambient temperature inside the equipment, $R_{th(hs-amb)}$, or $\theta_{(h-a)}$.

All of these three paths – and of course, the total path $R_{th(j-amb)}$ are measured in °C/W. This makes the total thermal path $R_{th(j-amb)} = R_{th(j-c)} + R_{th(c-hs)} + R_{th(hs-amb)}$.

The first of the three terms, $R_{th(j-c)}$, can be found in the data sheets provided by the manufacturer of the semiconductor device.

Path $R_{th(c-hs)}$ depends on the method used to mount the

transistor or diode to the heat-sink. In some cases the device may be mounted directly on to the heat-sink, but in others it may be necessary to provide some form of electrical insulation between the device and the heat-sink.

Unfortunately, electrical insulation also means some degree of heat insulation so a compromise is necessary. A thin mica washer can provide the electrical insulation. As the semiconductor's working voltage does not exceed a few tens of volts, a thick insulator is unnecessary.

Heat conduction is assisted by the use of silicon grease between the surfaces. Path $R_{th(c-hs)}$ can be considered to be between 0.1 and 0.7°C/W. In practice, a value of 0.4°C/W is usually acceptable for this term. This leaves the third term, $R_{th(hs-amb)}$, which needs to be evaluated.

Heat sink design steps

1. From the semiconductor data sheet, find $R_{th(j-c)}$ in °C/W.
2. Determine $R_{th(c-hs)}$ in °C/W. This value depends on the effectiveness of the thermal contact between the case of the semiconductor and the surface of the heat-sink. A value of 0.4°C/W will be a good enough approximation if the actual value is unknown.
3. Determine the power dissipated in the device,

(a) For power-amplifier transistors the power dissipated is,

$$P_D = P_{in} - P_{out} = V_{ce} \times I_c - P_{ac}$$

(b) For rectifier diodes,

$$P_D = V_D \times I_{ave}$$

4. Find,

$$R_{th(j-amb)} = \frac{T_j - T_{amb}}{P_D} \text{ in } ^\circ\text{C/W}$$

For silicon devices, maximum junction temperature T_j is usually 200°C, but to be safe it is better to design around 150°C. In some cases T_j may be specified lower than 200°C, so always check with the manufacturer's data before proceeding with the heat-sink design. Inside the equipment, the ambient temperature T_{amb} can be assumed to be 50°C.

5. Determine,

$$R_{th(hs-amb)} = R_{th(j-amb)} - R_{th(j-c)} - R_{th(c-hs)}$$

6. The surface area of the heat-sink required to provide the necessary $R_{th(hs-amb)}$ can be found from Table 1.

A variation of the thickness of the heat-sink between 1mm and 5mm does not have very much effect. It is surface area that counts. These figures should provide adequate design margins.

Note that the surface areas in the table are for one side of the heat-sink only, the total surface area is thus twice the table figure – plus twice the thickness of the metal.

All heat-sink surfaces are assumed to be painted matt-black and mounted horizontally. Vertical mounting increases the cooling effect and adds a further margin of safety. But bright metal surfaces will need the figures of Table 1 to be increased by some 33%.

Note that the figures were arrived by experimentation. After comparing various results using different methods for arriving at the necessary surface area for the same value of $R_{th(hs-amb)}$, agreement was not 100%.

Design examples

These two worked examples should help clarify the design procedure for you.

Example 1. A rectifier diode, for which the manufacturer's data gives $R_{th(j-c)} = 5^\circ\text{C/W}$, has a forward voltage drop 1.0V when the average current through it – or dc load – is 5A. The maximum junction temperature T_j of the diode is given as 100°C. Inside the equipment that the rectifier is to be used in, the ambient temperature will be assumed to be 50°C.

Design procedure

1. $R_{th(j-c)}$ is known to be 5°C/W.
2. Assume that $R_{th(c-hs)}$ will be 0.4°C/W.
3. Power dissipated in the diode is,

$$P_D = V_D \times I_{ave} = 1.0 \times 5 = 5\text{W for a } T_j \text{ of } 100^\circ\text{C}$$

$$R_{th(j-amb)} = \frac{T_j - T_{amb}}{P_D} = \frac{100 - 50}{5} = \frac{50}{5} = 10^\circ\text{C/W}$$

$$R_{th(hs-amb)} = R_{th(j-amb)} - R_{th(j-c)} - R_{th(c-hs)} = 10 - 5 - 0.4 = 4.6^\circ\text{C/W}$$

6. Referring to Table 1 gives the following dimensions for a suitable heat-sink.

For copper, 84cm² or 9.2cm×9.2cm
 For aluminium, 100cm² or 10cm×10cm
 For brass, 113cm² or 10.6cm×10.6cm
 For steel, 128cm² or 11.3cm×11.3cm

Example 2.

A BLW81 transistor is to be used as a vhf power amplifier to provide a cw output of 10W.

Design procedure

1. The thermal resistance from junction to case $R_{th(j-c)}$ is given by its manufacturer as 4.3°C/W.
2. Say R_{th} is 0.4°C/W.
3. Efficiency of the BLW81 is given as about 60% as a cw

Heat sink terms

Term	Description	Units
I_{ave}	Average current through diode	A dc
I_c	Transistor collector current	A dc
P_D	Power dissipated in transistor	W
P_{in}	Power input to device, dc	W
P_{out}	Output power – rf or af from transistor	W
$R_{th(c-hs)}$	Thermal resistance between device case and heat-sink	°C/W
$R_{th(hs-amb)}$	Thermal resistance between heat-sink and T_{amb}	°C/W
$R_{th(j-amb)}$	Thermal resistance between device junction and T_{amb}	°C/W
$R_{th(j-c)}$	Thermal resistance between device junction and case	°C/W
T_{amb}	Ambient temperature inside equipment	°C
T_j	Maximum temperature of device junction	°C
V_{ce}	Potential between collector and emitter of device	V
V_d	Voltage drop across diode at stated current	V dc

amplifier, so the input power for 10W output will be,

$$P_{in} = \frac{P_{out}}{0.6} = \frac{10}{0.6} = 16.7\text{W}$$

So,

$$P_D = P_{in} - P_{out} = 16.7 - 10 = 6.7\text{W}$$

$$R_{th(j-amb)} = \frac{T_j - T_{amb}}{P_D} = \frac{150 - 50}{6.7} = 14.9^\circ\text{C/W}$$

$$R_{th(hs-amb)} = R_{th(j-amb)} - R_{th(j-c)} - R_{th(c-hs)} = 14.9 - 4.3 - 0.4 = 10.2^\circ\text{C/W}$$

6. From Table 1, suitable heat-sinks are,

For copper, 29cm² or 5.4cm×5.4cm
 For aluminium, 35cm² or 5.9cm×5.9cm
 For brass, 37cm² or 6.4cm×6.4cm
 For steel, 130cm² or 11.4cm×11.4cm

My thanks to Anglia Microwaves of Billericay, Essex for their help in providing semiconductor data.

Table 1. These figures give you the surface area in cm² for one side of the heat sink for a known value of

$R_{th(hs-amb)}$ $R_{th(hs-amb)}$ °C/W	Material	Copper	Aluminium	Brass	Steel
1	734	—	—	—	—
1.5	342	—	—	—	—
2	220	376	477	—	—
2.5	175	277	302	711	—
3	135	187	210	338	—
3.5	116	149	175	222	—
4	94	120	150	165	—
4.5	85	102	115	132	—
5	70	83	90	109	—
6	53	68	72	82	—
7	41	61	63	66	—
8	37	55	58	61	—
9	33	39	44	47	—
10	29	35	37	41	—
11	26	30	33	36	—
12	24	29	30	32	—
13	22	27	29	30	—
14	20	25	26	27	—
20	14	17	18	20	—

Please quote "Electronics World" when seeking further information

and forward compatible. Further chips in the family, to the AC-3 standard for NTSC, will appear later, as will dual-standard devices. Philips Semiconductors (Eindhoven). Tel., 00 31 40 2722091; fax, 00 31 40 2724825.

Connectors and cabling

Thin s-m connectors. Up to 30 contacts are possible within a mounted height of only 2mm in the JAE LZ Series of wire/board connectors. Pitch is 1.25mm and there is a polarising key to prevent misalignment. Current rating is 1A and dielectric strength 500V ac. Flint Distribution. Tel., 01530 510333; fax, 01530 510275.

Surface-mounted coax connectors. Transradio's MMT series of s-m coaxial connectors provide very low vswr, low insertion loss and good shielding. There are models for use at frequencies from zero to 6GHz and a designers' kit and an extraction tool are available. MMT connectors consist of a s-m receptacle, mating with a right-angled plug, the receptacle having a male centre contact. The plug is nickel-plated, die-cast, and has a crimp ferrule, being suitable for cable types including RD316 double-screened 2.6mm diameter cable, RG174 and RG178 types. Receptacles are stamped and formed and has a gold-plated body and centre contact, standing 6.8mm off the board. Transradio Ltd. Tel., 0181-997-8880; fax, 0181-997-0116.

Displays

RGB dot-matrix led module. The American company Lumex announces a 5-by-7 dot-matrix RGB array of leds, 2.09in high. There are three leds per dot, giving a minimum of 300mcd at 10mA in blue and a viewing angle of 100°. Each colour of every dot may be addressed either individually or collectively and response time is short enough for fast animation. Dots are 0.3in diameter on 0.3in centres, two rows of 11 pins on the back, in 0.1in pitch being suitable for pcb mounting. Non-standard sizes or patterns can be made to order. Lumex Opto/Components Inc. Tel., 001 847 359-2970; fax, 001 847 359-8904

Filters

Drive-bay signal conditioners. Kemo has a range of active filters and signal conditioners that fit into the 5.25in floppy drive bay, which is now usually little used. Benefits of this type of mount are that screening is much better than when mounted in a card slot, and that the larger space allows better layout; filtering, too, is independent of the computer type and operating system. The Model 100 range has front-panel BNC connectors for inputs and cabling at the rear to connect the relevant data acquisition card. Signal conditioning may be computer-controlled or manual, the latter having front-panel switches to set functions. Kemo Ltd. Tel., 0181-658-3838; fax, 0181-658-4084.

Hardware

Desiccators. Brownell has a range of desiccators designed to eliminate humidity and condensation inside equipment housings. They are small polycarbonate mouldings in two types: one uses silica gel for general use, the other having molecular sieves for use with optical and laser equipment. Both types protect enclosures with volumes up to 100l, the type selected depending on volume and IP rating or equivalent. Each unit has a saturation indicator to show the need for reactivation or replacement. Brownell Ltd. Tel., 0181-965-9281; fax, 0181-965-3229.

No-tooling enclosures. K Box, a new division of Boss, has a new method of making low-cost plastic enclosures that need no tooling and are designed to order. They are made entirely of flat sheet material, so that no moulding or forming is needed and prototypes are available in a few days, modifications being easily accommodated. The cases can be produced in several materials in 2-10mm thickness, may be internally coated for shielding and designed to take rough handling. Boss Industrial Mouldings Ltd. Tel.,



01638 716101; fax, 01638 716554.

Access to bgas. Difficulties in attaching probes to ball-grid arrays for test purposes are eliminated by the adaptors now produced by Winslow International. They consist of a solder-down module to suit any device with a square matrix down to 1mm pitch (interstitial), using a hard-ball process with pins coming from the top, for which any interface arrangement can be supplied. Winslow International Ltd. Tel., 01874 625555; fax, 01874 625500.

Test and measurement

Analogue oscilloscope. Hitachi's V-252 20MHz, dual-channel oscilloscope is claimed to be the best value for money and, since the information supplied says it costs £0000, there is no arguing with that. Unfortunately, further enquiry reveals a price of £435, which is still pretty good; its warranty lasts three years. Y sensitivity is 1mV/div using x5 magnification and timebase speed a maximum of 0.1µs/div with a 10x magnifier. All the usual X and Y facilities are provided, as are accessories including a viewing hood, although an electrostatic charge repellent blue screen filter helps with high ambient light levels. Hitachi Denshi (UK) Ltd. Tel., 0181-202-4311; fax, 0181-202-2451.

Accessible oscilloscopes. While sacrificing nothing in the way of performance, Hewlett-Packard has reduced the resemblance of digital storage oscilloscopes to 747 flight decks, so that the new Infinium family of instruments looks rather more like a 'real' oscilloscope, with controls like the older, purely analogue types. Even so, with bandwidths to 1.5GHz, sampling rates to 8Gsamples/s and memory depths up to 64K/channel, these are top-end instruments. A Windows '95-based graphical user interface eases access to advanced

400MHz dso. The Tek TDS380 digital storage oscilloscope is the fastest in the TDS300 series, sampling at 2Gsamples/s and having a bandwidth of 400MHz. It is able to collect enough samples to show waveforms at full bandwidth to make single-shot acquisitions with timebase speeds to the maximum of 1ns/div, the high-speed sampling also reducing aliasing. There are 21 automatic waveform measurements and the four acquisition modes of sampling, peak detection, envelope and average with, in addition, live FFT analysis. A package called Option 14 provides GPIB and RS232-C interfaces, a VGA monitor and a Centronics port, all for remote control of the instrument from a pc. Waveforms displayed may be saved in TIF, PCX, BMP and EPS file formats. Thurlby Thandar Instruments Ltd. Tel., 01480 412451; fax, 01480 450409.

features via dialogue boxes and icons and an information system gives a guide to measurements of noise and jitter, to setting up advanced facilities such as FFTs and other, even basic procedures. Hewlett-Packard Ltd. Tel., 01344 366666; fax, 01344 362269.

Emissions testing. Laplace has added two new facilities to its 1.1GHz emc emission test SA1000 hardware and software, addressing problems of test site anomalies and widespread unfamiliarity with the subject. Ideally, test sites should be open, free of reflections and using a 4m mast, a set of conditions that is rarely met. The new software automatically corrects for test site errors. To take account of unfamiliarity with the process, the software now includes the

TestDirector mode, essentially an expert system that guides the user in the procedure. Laplace Instruments Ltd. Tel., 01692 500777; fax, 01692 406177.

Oscilloscope/recorder. Yokogawa's DL708 is the first in a series of instruments that combine the capabilities of oscilloscopes and recorders, costing less than either of similar performance. Display is on a 10.4in colour tft screen and there is a built-in thermal printer for hard copy. Data can be saved on the 1.2Gbyte hard disk or on a 3.5in floppy, the drive also being built in. There is a number of signal-conditioning modules, with bandwidth to 2MHz and 16-bit resolution, and up to eight channels may be plugged into the mainframe for simultaneous capture or recording. Analysis comprises voltage measurement, timing and FFT and waveforms can be analysed in terms of overshoot, period, standard deviation and rise time. Martron Instruments Ltd. Tel., 01494 459200; fax, 01494 535002.

Recorder with memory. The Hioki Model 8806 400ksamples/s memory recorder is a battery-powered, two-channel recorder that uses pc

Inrush protection. Joyin JNR thermistors are ntc metal-oxide ceramic types capable of suppressing inrush currents up to 12A in power supplies, lighting and in motor starting circuitry. They are available in cold resistances of 0.7Ω to 220Ω, maximum hot resistance being down to 32mΩ. Five body sizes and characteristics can be had, from the 10mm diameter JNR08 to the 25mm JNR20, with time constants of 36s to 115s. Anglia. Tel., 01945 474747; fax, 01945 474849.



Please quote "Electronics World" when seeking further information

sram cards to extend its capacity and to allow data to be analysed on the pc, operating in both recorder and memory modes. It will handle two analogue inputs and two logic signals, which are displayed on a 5in screen and printed immediately or saved for later printing. Telonic Instruments Ltd. Tel., 01734 786911; fax, 01734 792338.

Surface resistance tester. SRM100-3/B from Practical Power checks surface resistivity in the 10-100V range and displays the result on an analogue panel meter. It uses a single 2.5kg weight with a square probe and conforms to BS EN100015, has CE marking and EMC approval. Practical Power Ltd. Tel., 0118 9699170; fax, 0118 9699171.

Three data recorders. Gould has introduced three new recorders. DL250 performs the functions of data logging, multipoint recording, alarm annunciation and digital indication and is available in 16-64 input form, any combination of thermocouples, rtds, current and voltage being simultaneously monitored. RS232 or RS485 communication is provided. With up to 15 channels, the DL100 is a 100mm type having four direct inputs for mV, V and mA input and a variety of thermocouples and rtds, inputs being scalable for linear, square root and/or log. characteristics. Finally, the Digigraf is a paperless recorder for six channels, a 16-bit a-to-d converter giving good resolution; data points are stored in a buffer for display, alarm, calculation or archive. Many maths functions are available and results are displayed on a 5in colour lcd with touchscreen menus. Gould Instrument Systems Ltd. Tel., 0181-500-1000; fax, 0181-501-0116.

Curve tracer. Hameg's HM6042 semiconductor curve tracer is simple to use, is suitable for the testing of two and three terminal devices and gives an on-screen display of five curves, with additional information on an lcd. The five displayed curves indicate base voltage, base current, collector current, collector voltage and beta, characteristics of the device under test being entered by means of a front-panel keypad. A power limiter prevents damage to the device. Sets of curves may be stored in memory to ease comparison with other devices. Feedback Test and Measurement. Tel., 01892 653322; fax, 01892 663719.

Interfaces

Eight-channel driver ic. Allegro offers the UDN2987LW, designed as an interface between standard low-level logic and higher-power devices such as relays, motors and lamps. It is in a 20-pin, wide-body soic



and has thermal shutdown and output transient protection with clamp diodes for use with sustaining voltages up to 35V. Each channel has a latch to turn the channel off in the presence of excessive current, all channels being turned off in thermal shutdown, either condition being indicated by a common fault output. All outputs produce over 100mA continuously and inputs handle 5V and 12V logic, including ttl, Schottky ttl, dtl, pmos and cmos. Allegro Microsystems Inc. Tel., 01932 253355; fax, 01932 246622.

Literature

Burr-Brown CD-ROM catalogue. On one CD-ROM, Burr-Brown has collected the data from two 1300-page data books of analogue and mixed-signal devices and an applications handbook, together with search facilities. It is free and can be obtained by e-mail on cd-rom@burr-brown.com, from the website on <http://www.burr-brown.com/> or from Burr-Brown International. Tel., 01923 233837; fax, 01923 233979.

Rf transistors. Two catalogues from Ericsson on rf power transistors describe around 100 devices, ranging from 0.25W to 175W at frequencies from 300MHz to 2.2GHz, in both ldmos and bipolar types and contained in flange and surface-mounting packages. One of the publications is a short listing with a selection guide, while the other is a 350-page data book. Ericsson Components AB. Tel., 01793 488300; fax, 01793 488301.

DC-to-dc converters. Power Convertibles offers a six-page selector, giving details of the company's modules in the 0.75W to 100W range, including the new, low-cost 2W and 3W types. Those models in the 0.75-5W area are isolated-output types in s-m and sip/dip packages, providing 5V, 9V, 12V and 15V, while the WFC02R and WFC03R 2W and 3W models are

Keylock switches. New two and three-position, flush-mounted keylock switches in EAO-Highland's 04 family for use in control gear are tamper-proof and easy to clean. They fit a 30.5mm diameter hole and protrude a mere 2mm from the panel. Switches are sealed to IP65 and are rated at 500V, 10A, each being fitted with up to four snap-action, tactile contact blocks with plug-in screw terminals and a choice of silver or gold-on-silver contacts. EAO-Highland Electronics Ltd. Tel., 01444 236000; fax, 01444 236641.

lower in cost and are 81% efficient, in 32mm by 20mm by 10mm packages and 24-pin dils. There are also 8000V isolation types with output noise down to 1mV pk-pk. Power Convertibles Ireland Ltd. Tel., 00353 61 474133; fax, 00353 61 474141.

Power supplies

100W power supply. Weir Lambda's new Excel 100 is a 100W, four-output, convection-cooled supply for general-purpose use. It meets EN61000-3-2 but is available without power-factor correction for those applications in which it is not needed, in which case it costs less. It stands 42mm high without its cover (43mm with) and fits a 1U rack. As standard, outputs are three positive and a common zero, in a variety of arrangements. Input is 85-127V and 170-254V. Weir Electronics Ltd. Tel., 01243 865991; fax, 01243 866613.

60W dc-to-dc converters. The PKG 2000 1 family of 11mm high converters by Ericsson have a power density of 20W/cm³, working at an efficiency of more than 84%. The units are intended for use in decentralised 24V dc systems and accept inputs of 18-36V, turning off at 16V. PKG 2611 provides one output of 5V at 12A, the

Please quote "Electronics World" when seeking further information

PKG 2623 giving two of 12V at 4A, and all can be connected in parallel or series. If forced convection cooling is applied, the units need no heat sink up to 60°C. Acal Electronics Ltd. Tel., 01344 727272; fax, 01344 424262.

Radio communications products

Full duplex wlan chipset. Harris's *Prism 8*-chip set forms a full duplex, heterodyne radio transceiver with agc and carrying voice and data for use in wireless lans, point-to-point microwave, hand-held data transceivers and personal communications. It operates in the 1.7-2.7GHz band and carries out all necessary functions of amplification, up/down conversion and modulation/demodulation. Receiver sensitivity is -11dBm and agc range 90dB. Harris Semiconductor UK. Tel., 01276 686886; fax, 01276 682323.

PLL synthesisers. Vari-L *PLL300/400* series of phase-locked loop synthesisers for mobile communications, industrial use and wireless modems use a patented single-ended voltage-controlled oscillator for very low phase noise, low harmonic content and stability. The devices contain all necessary circuitry, including programmable dividers, phase detectors and loop

filter to make a complete circuit. There are frequency-agile devices, requiring serial programming and fixed-frequency units, with or without programming. In 13 variants, centre-frequency coverage is 755-992MHz, swinging ±15MHz, and two units of 2150MHz and 2450MHz centre frequency swinging ±50MHz. Acal Electronics Ltd. Tel., 01344 727272; fax, 01344 424262.

Protection devices

600W transient suppressors. Surface-mounted components from Semitron, using the glass passivated TVS diode technique as the axial-lead types, are now available. *SMB Series* transient suppressors have large contacts to handle fast rising pulses caused by lightning, inductive switching and esd and are rated at 600W during a 10x1000µs double exponential waveform. Fast turn on, a low clamping factor and low on impedance make them suitable for the protection of cmos ics, the surface-mounted form with its lower lead inductance leading to an application on high-speed, low-voltage data lines. Voltage stand-off range is 5-170V, clamping to 9V taking place in under 1ps. The devices are unidirectional or bidirectional; in the forward direction the SMB series sustains 100A for 8.3ms. Surtech Distribution Ltd. Tel., 01256 840055; fax, 01256 479785.

Fused resistor networks. Ericsson offers the *PBR53001/1* and *PBR53201/1*, which protect telecommunications line cards against induced voltages or direct shorts from underground power lines; they have integral thermal fuses and open safely when temperature in the device is greater than 240°C for 20s, protecting the pcb from melting or charring and reducing the risk of fire. Sustained overvoltage causes the resistive elements to crack and open, the fuses taking care of slow-burn conditions caused as above. Resistances are 50Ω and 20Ω respectively, matched to within ±0.5%. Ericsson Components AB. Tel., 01793 488300; fax, 01793 488301.

Switches and relays

Pcb switches. A new range of tactile, sealed switches for board mounting are 12.5mm square and allow keyboard layouts to be designed on a 12.7mm grid. All models in the *Secme Cosmos* range are proof against dust, splashing, wave soldering and cleaning solvent and are provided with removable covers in various shapes and colours. Silver or gold-plated dome contacts are used and the switches can have a red, green or yellow led. Ratings are 24V, 125mA, the gold ones switching down to 500µA. Insulation at 100V is over 1GΩ. Hawnt Electronics Ltd. Tel., 0121-784-3355; fax, 0121-783-1657.

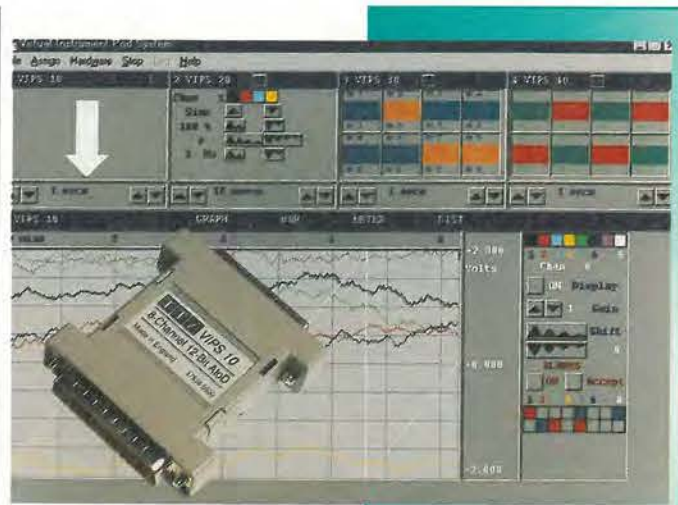

Transducers and sensors

Digital thermometer. *DS1624* from Dallas is a direct-to-digital temperature sensor having 256byte of eeprom on-chip to store temperature-related compensation information, eliminating the need for an external eeprom or the use of a microcontroller's memory; no external components at all are needed. It is chiefly intended for use in crystal compensation, in which the eeprom contains data on the frequency/temperature curve of the crystal. Temperature information is in the form of a 13-bit, two-complement word, equivalent temperature measurement being in the -55°C to 125°C in 0.03125° steps, which Dallas says is the smallest available. Supply is 2.7-5.5V and the device uses the two-wire bus with three-bit addressing for up to eight chips on the bus. Sensors come already calibrated. Dallas Semiconductor. Tel., 0121-7822959; fax, 0121-7822156.

Vision systems

Video conference kit. Premier's H.324-compliant kit consists of a PCI card, a colour camera and cable, the software providing facilities for video conferences, moving picture storage and frame grabbing, with set-up assistance for user details, e-mail address, resolution and picture quality. PAL, SECAM and NTSC formats are available and the system copes with communication between computers or connection to the internet over standard lines, ISDN or lan. The software allows storage of motion video direct to disk in an AVI file. Requirements are a 33MHz 486, 16Mbytes, 5Mbyte hard disk space and Windows '95. Premier Electronics Ltd. Tel., 01922 634652; fax, 01922 634616.

Data acquisition

Data acquisition pod for pcs. From Thurby-Thandar, the *VIPS 10* is a software/hardware package consisting of an 8-channel analogue/digital converter pod that fits a pc's parallel port to form a multi-channel system for applications from low-speed data logging to fast, 12-bit data acquisition, up to four such pods working from one printer port, from which the pods take power. *VIPS Windows* software ('95 or 3.1) gives display and control for up to four pods and supports direct data exchange between *VIPS* and other Windows applications. There are five types of pod for input/output in analogue/digital form, operating in any combination. And there are more to come. Thurby-Thandar Instruments Ltd. Tel., 01480 412451; fax, 01480 450409.

COMPUTER

Computers

Hardy palmtop. Fully proofed against most of the hazards of this world, *Ultimax* palmtop computers are 386SX-based (*Ultimax 2000*) and 486DX2 66MHz-based (*Ultimax 4000*) and operate for long periods on four AA batteries; they are made by ST Research Corp. Both models are provided with two PCMCIA slots, memory upgrade from 4Mbyte to 16Mbyte in the 2000 and from 8Mbyte to 32Mbyte in the 4000, a backlit display and keyboard, which is a sealed membrane, tactile type. The 2000 is dos-based and has a CGA lcd, while the 4000 runs Windows or dos software, has two serial ports, one external configurable connector,

Please quote "Electronics World" when seeking further information

a parallel port and an external keyboard connector, with a full-colour VGA lcd. Workstation Source Ltd. Tel., 0118 9227888; fax, 0118 9227820.

Development and evaluation

78K/IV development. New from NEC, a software system simulator for the 16-bit, 32MHz *78K/IV* microcontroller family. The simulator is Windows-compatible and simulates all peripheral functions of family devices, including timers, interrupt controller and i/o ports, allowing the simulation of waveform output, pull-up/down resistors, leds, keypads and external interrupt sources. In program development, there is single-step operation with a trace and access to source-level debugging. Cost of the simulator is £85. Sunrise Electronics Ltd. Tel., 01908 263999; fax, 01908 263003.

PIC emulator. RF Solutions' new single-board, in-circuit emulator for PIC microcontrollers provides real-time, non-intrusive development to 20MHz and costs less than £300. *ICEPIC Junior 5X* rapidly identifies system bugs in all members of the

Microchip PIC 12C5XX and 16C5X families. Source-level debugging is in either assembler or C, running in Windows; the system can therefore set an unlimited number of hardware breakpoints and arrange real-time emulation or single, multiple and procedure step execution. The emulator contains a Microchip emulation ic, 8K of emulation memory and an RS232 interface for data transfer at 115kb/s. RF Solutions Ltd. Tel., 01273 488880; fax, 01273 480661.

Mass storage systems

Rewritable disk/cd-rom drive. Panasonic's *LF-1196* is a removable, rewritable optical disk drive, combining an IDE ATAPI interface and Seagate software to provide 650Mbyte of storage on optical disk or to allow reading of 80-120mm cd-roms at up to 8x. There is no need to install an additional SCSI board, and Windows 3.1 and '96 versions of Seagate Backup Exec simplify backup and restore facilities by means of its easy Wizard interface for simplified backup and restore and an advanced interface for customised work. The drive is a half-height device, mounted vertically or

horizontally, with seek times of 92ms for both optical disks and CD-roms, data transfer proceeding at 1141Kb/s and 1200Kb/s respectively. Panasonic Industrial (Europe) Ltd. Tel., 01344 853157; fax, 01344 853081

Software

WorkBench PC v.3.0. Strawberry Tree's *WorkBench PC for Windows* has undergone a major upgrading to produce version 3.0 of this graphical data acquisition package, which allows the collection, analysis, display, logging of data and the control of external systems, the only programming needed being the shuffling of icons. A choice of modules provides for the representation of data inputs and outputs, controls, displays and functions for data reduction, signal analysis, maths and statistical operations, the modules being selected from a pull-down menu and "connected" on screen. The new version has a cut-and-paste facility for the selection of modules by mouse for copying to other parts of the worksheet or to a macro box. An optional tool caters for up to 20 pages to be designed either in this program

or to be imported as .BMP files and virtual instruments may be integrated into the design. Five new modules include a counter/timer, a formula interpreter, an RS232 output, trigger modules and a min/max module. Adept Scientific Micro Systems Ltd. Tel., 01462 480055; fax, 01462 480213.

Bar-code labels. *BAR-ONE Platinum v.4.0* from Zebra Technologies is the company's newest bar-code label design and print software, which allows users to access, process and combine variable information, including text and graphics, from many sources, this latest version having improved networking capability. It meets Microsoft's Open DataBase Connectivity standard and runs under Windows, so that a preview feature in the print queue allows a sight of the label before it is loaded for printing. Zebra Technologies Europe Ltd. Tel., 01494 472872; fax, 01494 450103.

ADVERTISE FREE OF CHARGE

Subscribers* to Electronics World can advertise their electronic and electrical equipment completely free of charge

Simply write your ad in the form below, using one word per box, up to a maximum of twenty words. Remember to include your telephone number as one word. **You must include your latest mailing label with your form.**

* This free offer applies to private subscribers only. Your ad will be placed in the first available issue.

This offer applies to private sales of electrical and electronic equipment only.

Trade advertisers - call Joanna Cox on 0181-652 3620

All adverts will be placed as soon as possible. However, we are unable to guarantee insertion dates. We regret that we are unable to enter into correspondence with readers using this service, we also reserve the right to reject adverts which do not fulfil the terms of this offer.

Please send your completed forms to:
Free Classified Offer: Electronics World, L333, Quadrant House, The Quadrant, Sutton, Surrey SM2 5AS

HART

The Home of *Hi-Finesse*. Its not what you do,
its **HOW** you do it that counts!.

Hart Audio Kits and factory assembled units use the unique combination of circuit designs by the renowned John Linsley Hood, the very best audiophile components, and our own engineering expertise, to give you unbeatable performance and unbelievable value for money.

We have always led the field for easy home construction to professional standards, even in the sixties we were using easily assembled printed circuits when Heathkit in America were still using tagboards! Many years of experience and innovation, going back to the early Dinsdale and Bailey classics gives us incomparable design background in the needs of the home constructor. This simply means that building a Hart kit is a real pleasure, resulting in a piece of equipment that not only saves you money but you will be proud to own.

Why not buy the reprints and construction manual for the kit you are interested in to see how easy it is to build your own equipment the HART way. The FULL cost can be credited against your subsequent kit purchase.



If you want the very best sound out of vinyl discs then you need our high quality preamplifier with Shunt Feedback equalisation. The K1450 also has an advanced front end, specially optimised for low impedance moving coil cartridges as well as moving magnet types. Selected discrete components are used throughout for ultimate sound quality. The combination of John Linsley Hood design, high quality components and an advanced double sided printed circuit board layout make this a product at the leading edge of technology that you will be proud to own. A recent review in "Gramophone" magazine endorsing this view. Bought in kit form our step by step instructions it is very easy and satisfying to assemble, or you can buy a factory assembled version if you wish.

This magnificent kit, comes complete with all parts ready to assemble inside the fully finished 228 x 134 x 63mm case. Comes with full, easy to follow, instructions as well as the Hart Guide to PCB Construction, we even throw in enough Hart Audiograde Silver Solder to construct your kit!

K1450 Complete Kit £116.58
K1450SA Audiophile Kit £138.94
A1450SA Factory assembled Audiophile unit £188.94



Highest quality, purpose designed, 'single ended' class 'A' headphone amplifier for 'stand alone' use or to supplement those many power amplifiers that do not have a headphone facility. Easy installation with special signal link-through feature, the unit uses our 'Andante' Ultra High Quality power supply. Housed in the neat, black finished, Hart minibox it features the wide frequency response, low-distortion and 'musicality' that one associates with designs from the renowned John Linsley Hood. Volume and balance controls are Alps 'Blue Velvet' components. Very easy to build, or available factory assembled, the kit has very detailed instructions, and comes with Hart audiograde silver solder. A valuable personal listening option and an attractive and harmonious addition to any hi-fi system.

K2100 Complete Standard Kit £112.50
K2100SA 'Series Audiophile' Kit with selected audiophile components £115.46
A2100SA 'Series Audiophile', Factory Assembled £115.46
CM2100 Construction Manual £2.50

"Andante" Linear Technology AUDIOPHILE POWER SUPPLIES

The HART "Andante" series power supplies are specially designed for exacting audio use requiring absolute minimum noise, low hum field and total freedom from mechanical noise. Utilising linear technology throughout for smoothness and musicality makes it the perfect partner for the above units, or any equipment requiring fully stabilised $\pm 15\text{V}$ supplies. There are two versions, K3550 has 2 $\pm 15\text{V}$ supplies and a single 15V for relays etc. K3565 is identical in appearance and has one $\pm 15\text{V}$. Both are in cases to match our 'Chiara' Headphone Amplifier and our K1450 'Shunt Feedback' Pickup preamp.

K3550 Full Supply with all outputs £94.75
K3565 Power Supply for K1450 or K2100 £84.42
A3550 Factory Assembled Full Supply £147.25

SPEAKER DESIGN SOFTWARE.

VISATON "Speaker Pro 6" is a complete speaker design program for use on IBM machines. Covers cabinet and crossover design and contains a full expandable database of drive units. Earning a "most recommendable" accolade it tests this program is ideal for the professional speaker builder or serious audiophile.

0303 Speaker Pro 6, 3.5" Disk £45.51
0309 Demo Version with Database £9.28

SPEAKER DAMPING MATERIALS

Polyester Wool and Pure Lambs Wool both have optimal damping properties and are pleasant to handle. Standard 125g bag is sufficient for 20 litres enclosure volume.

5070 Polyester Wool, 125g £3.20
5069 Pure Lambs Wool, 125g £6.73

ROARING SUBWOOFER.

A full revised kit will be available soon for this excellent and imaginative design from Russel Brodon (WW Feb.97). The latest design will use the 30mm maximum cone displacement of the 10" VISATON GF250 Driver to give even better performance at slightly reduced cost. Featuring a rubber suspended fibreglass cone, extended pole plate, vented magnet, Kapton carrier and dual 40hm voice coils the GF250 is unbelievably good value at only £111.45 each.

SPECIAL OFFER! SOLENOID CONTROLLED FRONT LOAD CASSETTE DECK SFL800

High quality (0.08%W&F) cassette mechanism with capability of using standard or downstream monitor R/P head. Offers all standard facilities under remote, logic or software control. The control requirements are so simple that for many applications not needing all functions manual switches will suffice. Power requirements are also simple with 12v solenoids and 12v speed controlled Motor, total power requirement being under 300mA. Logic control and wiring circuits are included free with each deck.

SFL800 Deck with Standard stereo head £29.50
SFL800D Fitted with High Quality Downstream monitor head. £44.90
(The Head alone is normally over £60!)

HART TECHNICAL BOOKSHELF

Try us for:- Bigger Range of Books, Better Prices,
NO "28 Day Wait"

"AUDIO ELECTRONICS" John Linsley Hood £18.99*
"THE ART OF LINEAR ELECTRONICS"
John Linsley Hood, 1994 £16.95*
"THE ART OF ELECTRONICS" Horowitz & Hill £35.00*
"DIGITAL AUDIO AND COMPACT DISC TECHNOLOGY"
3rd.Edn. 0-240 51397 5 £19.95*
"INTRODUCING DIGITAL AUDIO CD, DAT AND SAMPLING"
ISBN 1870775 22 8 £7.95
"ACTIVE FILTER COOKBOOK" Don Lancaster £19.95
"THE ART OF SOLDERING" 0-85935-324-3, 0 £3.95
"TOWERS' INTERNATIONAL TRANSISTOR SELECTOR"
0-572-01062-1 £19.95*
"AUDIO" F.A.Wilson, BP111 £3.95
"HOW TO USE OSCILLOSCOPES & OTHER TEST EQUIPMENT"
R.A.Penfold, BP267 £3.50
"THE HART PRINTED CIRCUIT BOARD CONSTRUCTION GUIDE"
..... £2.50
"A SIMPLE CLASS A AMPLIFIER"
J.L.Linsley Hood M.I.E.E. 1969. RLH12 £2.75
"CLASS-A POWER" Single Ended 15W Amp.
J.L.Linsley Hood M.I.E.E. 1996. RLH13 £2.50

LOUDSPEAKERS; THE WHY AND HOW OF GOOD REPRODUCTION. G.Briggs, 1949. £8.95
"THE LOUDSPEAKER DESIGN COOKBOOK"
Vance Dickason, (5th Edn.) £23.95*
ELECTROSTATIC LOUDSPEAKER DESIGN AND CONSTRUCTION Ronald Wagner, BKT6 £15.95
"THE ELECTROSTATIC LOUDSPEAKER DESIGN COOKBOOK"
Roger P.Sanders, 1995 £24.95
"BULLOCK ON BOXES" Bullock & White £10.95
"AN INTRODUCTION TO LOUDSPEAKERS & ENCLOSURE DESIGN" V. Capel, BP256 £3.95
"LOUDSPEAKERS FOR MUSICIANS" BP297 £3.95
"THEORY & DESIGN OF LOUDSPEAKER ENCLOSURES"
J.E.Benson £21.95
"QUICK & EASY TRANSMISSION LINE SPEAKER DESIGN"
Larry D.Sharp £8.95
"THE COUPLED CAVITY HANDBOOK" David Purton £4.90
"VISATON. HOME HI FI CATALOGUE." Full Specifications and Thiele Small Data on all Drive Units £4.50
"VISATON. CAR HI FI CATALOGUE." In car guide £3.50
"VISATON. CABINET PROPOSALS" Book 1. In GERMAN £6.50
"VISATON. CABINET PROPOSALS" Book 2. In GERMAN £6.50
"SPEAKER PRO 6." VISATON Cabinet Design Software £45.51
"SPEAKER PRO 6." Demo Version with drive unit database £9.28

"VALVE AMPLIFIERS" Morgan Jones, 1995/6 £24.50
THE VTL BOOK David Manley 1994. BKVT1 £17.95
MULLARD TUBE CIRCUITS FOR AUDIO AMPLIFIERS BKAA27 £11.95
"THE WILLIAMSON AMPLIFIER." 0-9624-1918-4 £6.95
AN APPROACH TO AUDIO FREQUENCY AMPLIFIER DESIGN. GEC 1957 £17.95
AUDIO ANTHOLOGIES, articles from Audio Engineering. Six volumes covering the days when audio was young and valves were king! BKAA3/1 to 6. All £12.95 each
"THE RADIOTRON DESIGNERS HANDBOOK" (CD) £49.00
"PRINCIPLES OF ELECTRON TUBES" H.D.Reich PH.D. £25.95
"POWER AMP PROJECTS" Anthology, 1970-1989. £15.50
"WORLD TUBE DIRECTORY" 1996-7 Sourcebook of valve related products £5.95
Fuller descriptions of the contents of all our books is given in our full catalogue, price £4.50

Postage on all books, unless starred, is only £2 per book, maximum £4.50 for any number, any size! Starred items are heavy books costing £3.50 to send.

Don't forget No waiting at HART! All listed books are normally in stock! Just ring with your Credit Card Number for instant despatch.

POSTAGE on UK Orders up to £20 is £2. Over £20 is £4.50.
OVERSEAS Please Enquire.
Fuller Details of ALL kits are given in our List, FREE on request.



This fantastic John Linsley Hood designed amplifier is the flagship of our range, and the ideal powerhouse for your ultimate hi-fi system. This kit is your way to get £K performance at bargain basement prices. Unique design features such as fully FET stabilised power supplies give this amplifier World Class performance with startling clarity and transparency of sound, allied to the famous HART quality components and ease of construction. Standard model comes with a versatile passive front-end giving 3 switched inputs, with ALPS precision "Blue Velvet" low-noise volume and balance controls, no need for an external preamp! Construction is very simple and enjoyable with all the difficult work done for you, even the wiring is pre-terminated, ready for instant use! All versions are available with Standard components or specially selected Super Audiophile components and Gold Plated speaker terminals and all are also available factory assembled.

K1100 Complete STANDARD Stereo Amplifier Kit, £415.21
K1100S Complete SLAVE Amplifier Kit, £353.62
K1100M Complete MONOBLOC Amplifier Kit, £271.20
RLH11 Reprints of latest Amplifier articles £1.80
K1100CM Construction Manual with full parts lists £5.50



Now you can throw out those noisy ill-matched carbon pots and replace with the famous Hart exclusive ALPS 'Blue Velvet' range components only used selectively in the very top flight of World class amplifiers. The improvement in track accuracy and matching really is incredible giving better tonal balance between channels and rock solid image stability. Motorised versions have 5v DC motor.

MANUAL POTENTIOMETERS

2-Gang 100K Lin. £15.67
2-Gang 10K, 50K or 100K Log £16.40
2-Gang 10K Special Balance, zero crosstalk and zero centre loss. £17.48

MOTORIZED POTENTIOMETERS

2-Gang 20K Log Volume Control £26.20
2-Gang 10K RD Special Balance, zero crosstalk and less than 10% loss in centre position £26.98

TOROIDAL MAINS & OUTPUT TRANSFORMERS FOR EL34, 32W VALVE AMPLIFIER

Special set of toroidal transformers, 2 output & 1 mains for the "Hot Audio Power" valve amplifier design described in the Oct. 1995 issue of "Wireless World". Total Wt 4.8Kg. Special price for the set. £99, Post £8

RJM1. Photocopies of the Article by Jeff Macaulay. £2

PRECISION Triple Purpose TEST CASSETTE TC1D.

Are you sure your tape recorder is set up to give its best? Our latest triple purpose test cassette checks the three most important tape parameters without test equipment. Ideal when fitting new heads. A professional quality, digitally mastered test tape at a price anyone can afford.

Test Cassette TC1D. Our price only £9.99

Send for Your FREE copy of our LISTS

24 Hr. ORDERLINE 01691 652894
Fax. 01691 662864

All Prices include UK/EC VAT.



APPLICATIONS

A battery of chargers

Battery design being what it is, battery chargers are not the simple devices they used to be. They even talk to computers, as Philip Darrington explains.

Ever since people decided they needed to carry computers, tape players, radios, telephones and all those life-enhancing games around with them, and the parking-meter reader stopped writing the numbers in a little book, the battery makers have had an extended birthday. But the one-discharge type of battery came a bit expensive – and a bit too big and heavy – for some of the current-hungry devices, so rechargeable types were needed.

Cue for new chemistry: you can now be faced with nickel-cadmium, nickel-metal hydride, rechargeable alkaline and lithium ion batteries all in the same household and all needing chargers with various protective limiting facilities. Maxim makes ics for the purpose, described in the *Maxim Engineering Journal* vol.27, from which this is an extract.

NiCd versus NiMH

If you need a high current in short bursts, nickel-cadmium (NiCd) batteries are the choice; they have a lower capacity than lithium ion (Li+) or nickel-metal hydride (NiMH) types, but possess low impedance.

NiMH batteries are in some ways similar to NiCd ones, but have more capacity, although self-discharge rate is about double at 1% of capacity per day and they do not, therefore, hold a charge for long periods. Both types can be fast-charged in about an hour by a current equal to the capacity in amp-hours, although this process will not give a full charge because of losses; to get a full charge, charge for longer or with a higher current.

Charge termination is slightly different for the two types: charging a NiCd battery should stop when its terminal voltage begins to decrease, because the thing will probably explode if provoked for much longer; an NiMH charge should be stopped when the voltage peaks.

You can trickle-charge both types without worrying about stopping the charge or checking the voltage because temperature rise is not nearly enough to cause any trouble. Trickle current should be around (capacity in Ah)/15.

Lithium-ion batteries
Li+ batteries have the edge over other rechargeables as

regards capacity. Compared with NiMH types, energy per unit volume is 10%-30% better, but energy per unit mass is about double, since they are lighter.

But they are not perfect; current and voltage both need watching in both charge and discharge regimes (if you keep discharging the battery to a low voltage, it loses capacity). For these reasons, Li+ packs usually have a fuse to prevent overcurrent and a switch to disconnect the battery if it looks like venting or, to put it another way, exploding.

Li+ battery packs usually use mosfets to disconnect the battery if it is being subjected to under or overvoltage. These mosfets also make a different charging method possible, in which a constant-current charge without voltage limit is applied, the mosfets turning on and off as needed to maintain the battery voltage. Battery capacitance slows

Fig. 1. Simple linear charger for one lithium ion cell. Heat generated by this type confines its use to the cradle type of separate charger.

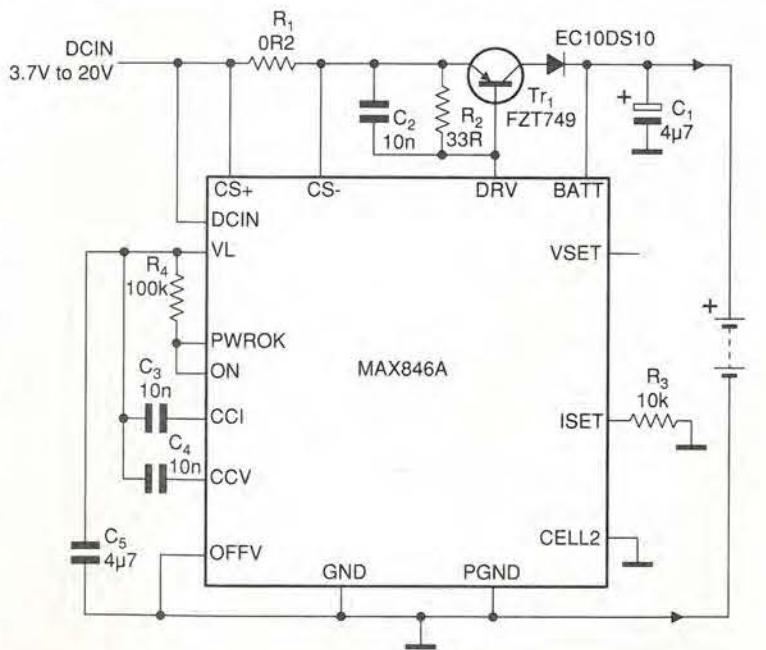

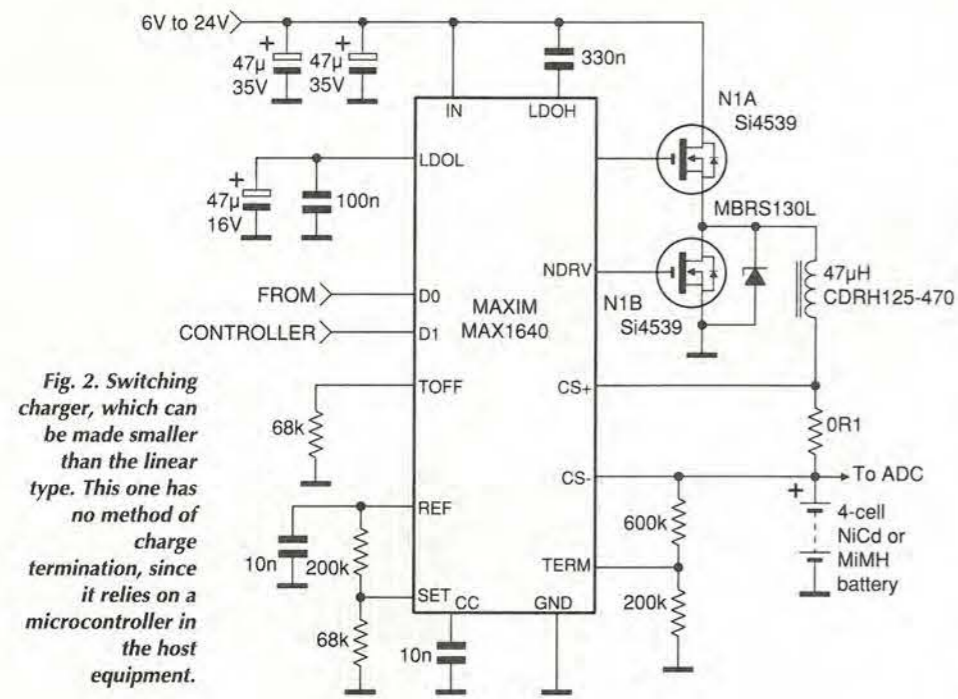
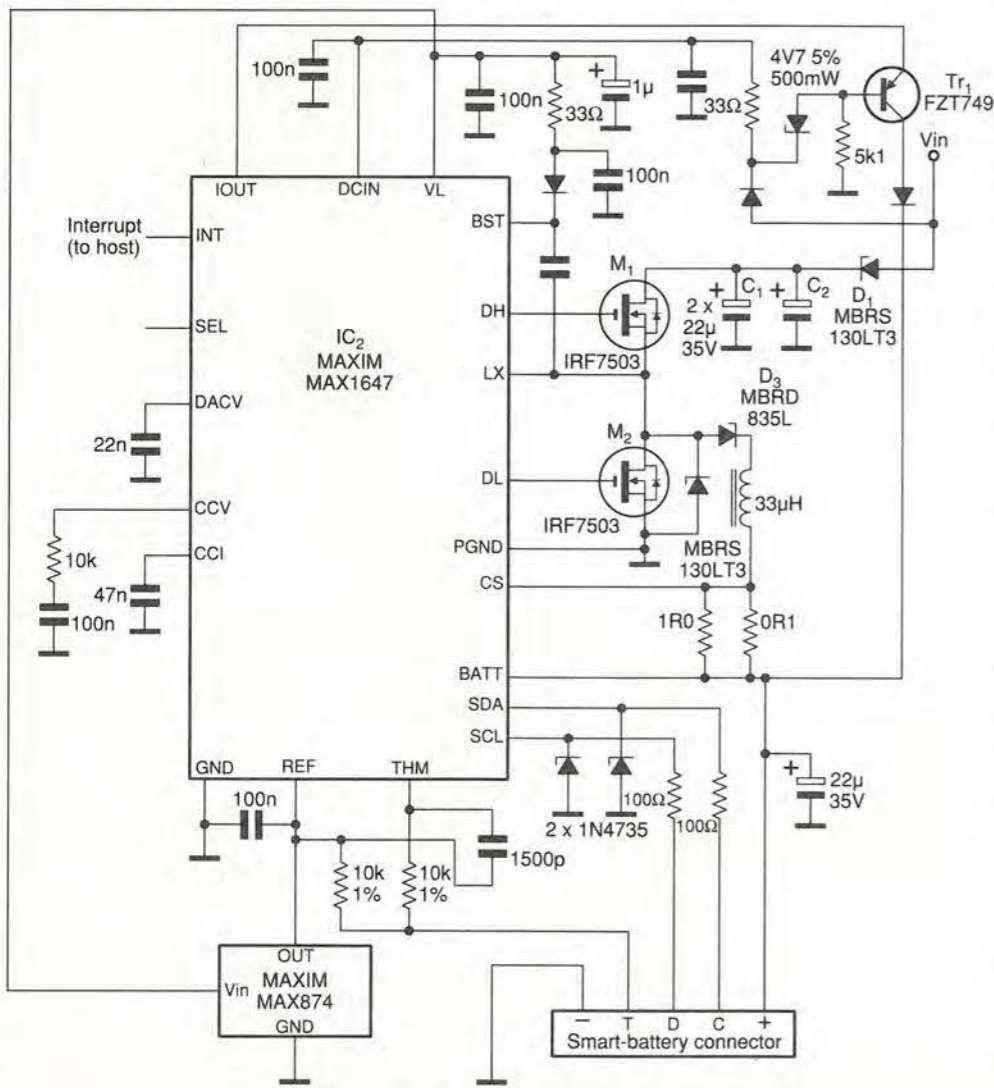

Fig. 2. Switching charger, which can be made smaller than the linear type. This one has no method of charge termination, since it relies on a microcontroller in the host equipment.

Fig. 3. Charger for smart battery packs, using the SMBus interface. This one is 89% efficient. The MAX874 is a voltage reference.



down the voltage rise, but care is needed because the capacitance varies with frequency and with battery type.

In some kinds of equipment powered by, say, alkaline AA batteries, an intermittent load calls for more power than the battery can supply, for example during transmission in a two-way pager. In such a case, the answer is to have an extra, rechargeable type to answer the call for action and then to relapse into relative inactivity while it is recharged by the main alkaline battery ready for the next assault on its composure.

Chargers

Separate chargers, including the cradle type into which the cellphone, for example, or its battery pack fits do not have to be extravagantly efficient, since any heat generated, within reason, will not affect the equipment.

Figure 1 shows the simplest type of charger for this purpose—a linear regulator designed to charge one LI+ cell at 1A. An external power transistor drops the input voltage to 2V, the transistor dissipating most of the power in the circuit, the MAX846A charger ic, with its internal reference, staying relatively cool and therefore stable. Series input current-sensing resistor R1 and the ISET resistor R3 set the current regulation level and ISET the current limit, in this case 1A. Terminal VSET allows for voltage limit adjustment.

If the series-pass transistor is contained in a small volume without cooling, heat might still be a problem. For four NiCd cells charging at 1A, total power dissipation could be 8W, 4.4W of that being in the transistor.

Built-in chargers are another matter; the life of a heated battery is shorter, but not necessarily sweeter. Linear regulators have to give way to switching regulators, which dissipate little power, regardless of the input/output difference, and which are smaller than the linear type. There is the disadvantage of the necessary filter, of course, although the battery capacitance can form part of the filter, if C is suitable for the filter frequency.

Noise can be a nuisance, but some switches can be synchronised to an external signal to move the noise away from sensitive frequency bands. Good layout and shielding will avoid most of the trouble.

A four-cell NiCd/NiMH/ charger of the switching type is shown in Fig. 2. This the kind that works with a microcontroller to terminate the charge, having no provision for that in itself. If the equipment has no such controller, it only needs to be an inexpensive type with an a-to-d converter. The MAX1640 chops the input by means of the switching transistor N1A and synchronous rectifier N1B, the chopped waveform being imposed across the inductor to form a current source, the diode D2 preventing the

battery reversing the process and supplying current to the source. In response to controller signals on pins D0 and D1, there are three modes of working: fast charge, pulse-trickle charge and top-off charge. Fast charging produces a current of 1.5A, in top-off the current is about a quarter of the fast-charge current, or 381mA, and in trickle charge it is the same but pulsed with a 12.5% duty cycle. All these current levels are produced by the voltages on SET and REF pins and the value of the current-sense resistor, in this case 0.1Ω, all selected by the microcontroller input signals.

If everything goes according to plan, the circuit stops the charge when the battery voltage rise becomes zero or negative, depending on whether the battery is an NiMH or NiCd type. If it doesn't, the potential divider R6,7 are there to set a limit to which the battery voltage may rise, in this case 8V.

Smart-battery chargers

One has the thought that battery design might perhaps be getting a little out of hand when even battery packs have microcontrollers. Nevertheless, they do and are useful in that one type of charger is able to cope with any kind of battery that conforms to the smart-battery standard.

You can also replace a battery with any other that conforms to the standard, which is concerned with the manner in which the battery pack connects to the equipment it powers and the way in which it communicates with it using the Intel SMBus, itself derived from the I²C protocol. There

are many I²C-compliant ics around already. Figure 3 shows a charger with an SMBus interface.

Currents under 31mA, which corresponds to the five least significant bits from the a-to-d converter in the host controller, come from an internal linear current source, since the switching regulator and its low-value current-sense resistor cannot handle the 1mA resolution needed. Currents over 31mA are provided by a switching regulator to maintain an efficiency of 89%, but the linear source remains active so that monotonicity at the a-to-d doesn't suffer whatever the value of the sense resistor or current-sense amplifier offset.

If the input voltage is much greater than the battery voltage, transistor Q1 helps to relieve the power dissipation in the internal linear regulator; inputs up to 28V are acceptable and outputs are selectable at 1A, 2A and 4A. Switching is at 250kHz, the size of the inductor reflecting the fact.

Technical support

Maxim, Unit 3, Theale Road, Theale, Berkshire RG7 4XX. Tel., 01734 303388; fax, 01734 305577.

ADVERTISERS INDEX

Airlink Sales	1031
Anchor Supplies	1011 and 1031
CMS	1007
Cook International	1016
Conford Electronics	981
Colomor Electronics	1004
Crownhill Associates	1012
Dataman	OBC
Display Electronics	1029
Equinox Technology	IBC
Halcyon Electronics	1004
Hart Electronics	1044
Ice Technology	977
IOSIS	1033
John's Radio	1050
JPG Electronics	1047
Keytronics	1038
Labcenter Electronics	972
M&B Radio	981 and 1015
Milford Instruments	1009
Number One Systems	1021
Olson Electronics	970
Pico Technology	993
Pyramid Electronics	1012
Quickroute Systems	975
Ralfie Electronics	1055
RD Research	995
Seetrex	997
Sowter Transformers	993
Stewart of Reading	1033
Surrey Electronics	1031
Tandem Technology	IFC
TDC	993
Telford Electronics	1025
Telnet	1009
Temwell	1004
Those Engineers	975
Tie Pie	989
Wood & Douglas	981

New Special Offers

Mini waterproof TV camera 40x40x15mm requires 9 to 13 volts at 120mA with composite video output (to feed into a video or a TV with a SCART plug) it has a high resolution of 450 TV lines. Vertical and 380 TV lines horizontal, electronic auto iris for nearly dark (1 LUX) to bright sunlight operation and a small lens with a 92 degree field of view, it focuses down to a few CM. It is fitted with a 3 wire lead (12v in and video out). Now also available with wall mount tilt and swivel case (at the same price) £93.57 + VAT - £109.95 or 10+ £89.32 + VAT - £104.95	Nickel Metal Hydride AA cells high capacity with no memory, if charged at 100mA and discharged at 250mA or less 1100 mAh capacity (lower capacity for high discharge rates).....£3.75
Board camera all with 512 x 582 pixels 4.4 x 3.3mm sensor 9-13 volts power supply and composite video out. All need to be housed in your own enclosure and have fragile exposed surface mount parts. 47MIR size 60 x 36 x 27mm with 6 infra red leds (gives the same illumination as a small torch would) £50.00 + VAT - £58.75	Stock of 4 x 42 x 1.6mm nicad batteries 171mm x 16mm dia with red and black leads 4.8v.....£5.95
40MP size 39 x 38 x 23mm spy camera with a fixed focus pin hole lens for hiding behind a very small hole. £57.00 + VAT - £66.98	5 button cell 6V 280mAh battery with wires (Narta 5 x 2500).....£2.45
40MC size 39 x 38 x 28mm camera for 'C' mount lens this gives a much clearer picture than the small lenses. £68.78	Oxford 866 battery pack 12v 1.6AH contains 10 sub-C cells with solder tabs (the size most commonly used in cordless screwdrivers and drills 22 dia x 42mm tall). It is easy to crack open and was manufactured in 1994. £8.77 each or £110.50 per box of 14
Standard 'C' mount lens F1.6 16mm for 40MC.....£26.43 + VAT - £31.06	BCI box 190 x 106 x 50mm with slots to house a pcb the lid contains an edge connector (12 way 8mm pitch) and screw terminals to connect to wires and 5 slide in cable blanks.....£2.95
High quality stepping motor kits (all including stepping motors) 'Comstep' independent control of 2 stepping motors by PC (through the parallel port) with 2 motors and software.....£27.00	7 segment common anode led display 12mm.....0.45
Kit - £67.00. Ready built - £99.00	GoAs FET low leakage current 88873.....£12.95 each
Software support and 4 digital inputs kit.....£27.00	40MC size 39 x 38 x 28mm camera for 'C' mount lens this gives a much clearer picture than the small lenses. £68.78
Power interface 4A kit.....£36.00	Standard 'C' mount lens F1.6 16mm for 40MC.....£26.43 + VAT - £31.06
Power interface 8A kit.....£46.00	DC-DC converter Reliability model V12P5 12v in 5 v 200ma out 300v input to output isolation with data.....£1.95
Stepper kit 4 (manual control) includes 200 step stepping motor and control circuit.....£38.34	SU52 ULN limiting amplifier L.C. 16 surface mounting package with data sheet.....£1.95
DTA30 Hand held transistor analyser. It tells you which lead is the base, the collector and emitter and if it is NPN or PNP or faulty (NEW VERSION does not say FETs & SCRs are transistors) DTA30.....£38.34	DC-DC converter Reliability model V12P5 12v in 5 v 200ma out 300v input to output isolation with data.....£1.95
HMA20 hand held MOSFET analyser identifies gate drain and source and if P or N channel HMA20.....£38.34	500pf compression trimmer.....60p
Speaker cabinets 2 way speaker systems with Motorola tweeters	200mA transistor Hfe 9v and 1.5v battery test.....£9.95
Speaker dia.....15"	Hand held ultrasonic remote control.....£3.95
Power rating.....250WRMS 12"	CV2486 gas relay 30 x 10m dia with 3 wire terminals will also work as a neon light.....20p each or £8.50 per 100
Impedance.....8ohms 175WRMS 100WRMS	Verbatim R300NH Streamer tape commonly used on nc machines and printing presses etc. it looks like a normal cassette with a slot cut out of the top.....£4.95 each (£3.75 100+)
Frequency range.....40hz-20khz 45hz-20khz 60hz-20khz	Hastek compound tube.....£1.95
Sensitivity (W/V/M).....97dB 92dB	NH3-2405-ES 5-24v 50mA regulator ic 18:254vcc input 8 pin DIL package.....£3.49 each (100+ £2.25)
Size in mm.....50x70x340 450x60x415 315x60x230	LM555 timer ic.....16p
Weight.....21.1kg 16.8kg 7.4kg	8 pin DIL socket.....6p
Price each for black.....£130.95 £99.99 £54.94	
Grey felt coating.....£159.97* £119.97* £64.99	
(* - not normally in stock allow 1 week for delivery)	
Power amplifiers 19" rack mount with gain controls & VU meters	
STA300 2 x 190Wrms (4ohm load) 11kg.....£339.00	
STA900 2 x 490Wrms (4ohm load) 15kg.....£585.00	
LED's 3mm or 5mm red or green.....7p each.....yellow 11p each	
Cable ties.....1p each.....£5.95 per 1000.....£49.50 per 10,000	
Rechargeable batteries	
AA (PP7) 500mAh.....0.99	AA 500mAh with solder tags.....£1.55
AA 550mAh.....£1.75	C (PP11) 1.2AH.....£2.20
C 2AH with solder tags.....£3.60	D (PP21) 1.2AH.....£2.60
D 4AH with solder tags.....£4.95	PP3 1.4V 110mAh.....£4.95
1/4AH with solder tags.....£1.55	Sub-C with solder tags.....£2.50
AAA (PP16) 180mAh.....£1.75	1/3 AA with tags (phlips CTV).....£1.95

All products advertised are new and unused unless otherwise stated. Wide range of CMOS TTL 74HC 74F Linear Transistors kits, rechargeable batteries, capacitors, tools etc always in stock. Please add £1.95 towards P&P (orders from the Scottish Highlands, Northern Ireland, Isle of Man, Isle of Wight and overseas may be subject to higher P&P for heavy items). VAT included in all prices. **JPG Electronics, 276-278 Chatworth Road, Chesterfield S40 2BH** Mastercard/Visa Orders (01246) 211202 Fax: 550959 Callers welcome 9.30am to 5.30pm Monday to Saturday

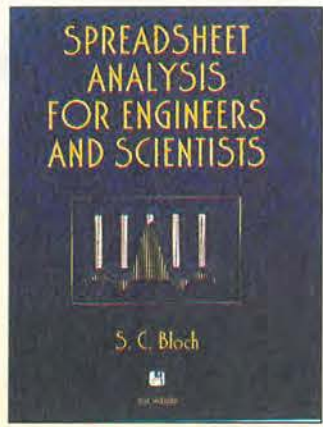

Spreadsheet Analysis for Engineers and Scientists

With this practical, hands-on guide, engineers and researchers learn, quickly and easily, the latest and most useful electronic spreadsheet methods. Using a variety of interactive techniques, including worksheets, self-test and practical programs on the included disk, *Spreadsheet Analysis for Engineers and Scientists* show you how to harness the power and versatility of spreadsheet programs, including those that contain the fast Fourier transform, complex operations and Bessel functions, and how to customise your own applications.

Includes disk
0471 126837, 336pp
UK £37.50, Europe £39.50, ROW £49.50

Electronic Component Reliability

Fundamentals, Modelling, Evaluation and Assurance
This text approaches the quality and reliability of electronic components from a unique standpoint. Traditionally the twin subjects of reliability physics and reliability statistics have been treated as separate entities. Here, the author examines both areas and reveals how failures develop over a period of time.

0471 952966, 374pp
UK £50.50, Europe £53.50, ROW £66.50



Fuzzy Logic Implementations and Applications

Offering a new perspective on a growing field, this text explores the many hardware implications of fuzzy logic based circuits. As use of AI increases, so the VLSI area of circuits is becoming a growth subject. Opening with an overview of fuzzy sets and fuzzy logic the book moves on to cover a range of non-standard solutions for fuzzy logic VLSI circuits. Future trends, new concepts and ideas are all examined and supported with practical examples from the author's research.

ISBN 0471 950599, approx 346pp,
UK £50.50, Europe £53.50, ROW £66.50

Microelectronic Switched-Capacitor Filters

Switched-capacitor filters and associated MOS integrated circuits are now an established technology finding applications in the telecommunications and instrumentation fields. With unrivalled breadth of coverage, this book surveys the design techniques of an important class of analogue signal processing systems. An accompanying diskette containing a comprehensive computer-aided design package (ISICAP) enables readers to gain a greater depth of understanding of the described techniques. Containing both source code

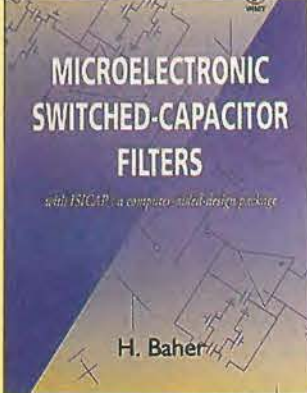

files and an executable version of the main design package, this alone will be an indispensable tool for many circuit designers.
Includes disk
0471 954047 384pp
UK £75.50, Europe £79.00, ROW £92.00

The I²C Bus

From theory to Practice
With a special emphasis on the I²C Bus, this guidebook through the world of micro controller-managed serial buses presents comprehensive coverage of the theory necessary to design the best possible communications bus for any particular application. The book examines typical industrial and consumer applications and enables the reader to design effectively in a real-world environment. A disk containing software for the I²C bus is also included.
Includes disk
0471 96268 6, 314pp
UK £54.50, Europe £56.50, ROW £65.00

High Frequency Analog Integrated Circuits

As one of the first textbooks to discuss integrated circuit design considerations and

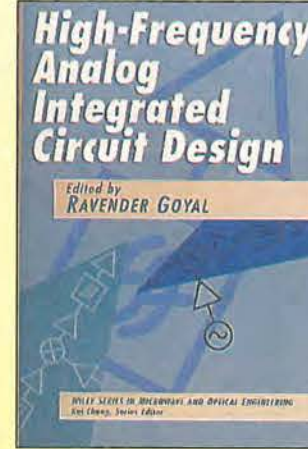

actual designs from the basic concepts, this title provides a solid background in designing basic circuits, advanced circuits and synthesis techniques.
0471 530433 424pp
UK £80.00, Europe £83.00, ROW £95.00

Speech Coding

A Computing Laboratory Textbook
This is one of the first lab manuals with software dedicated exclusively to speech processing and coding. It takes advantage of the development of the personal computer by making this technology accessible to a wider audience. The manual and Dos based software together create a user-friendly digital signal processing lab which allows the user to

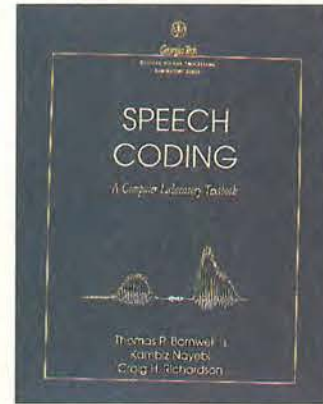

perform a wide variety of speech coding and speech processing experiments. The text presents and explains a set of basic speech coders analytically and in terms of the specific parameters controlling each coder. The manual leads the student through the experimental process of understanding how speech coders work and sound via over 70 exercises and projects. The class-tested menu-driven, Dos-based software can be operated by students with little or no training.
Includes disks
0471 516929, 194pp,
UK £31.97, Europe £33.97, ROW £39.97

Solar Cells and their Applications

The past decade has witnessed numerous important breakthroughs in solar cell technology, many of which have occurred in just the past few years. Far cheaper to produce and maintain, exhibiting a longer lifetime, and considerably more efficient than ever before, solar cells are, at last, in a position to compete with traditional technologies for both small and large-scale energy conversion applications. Including contributions from some of the world's leading experts in the field, this book reports the most important recent advances in solar cell technology. From in-depth discussions of breakthroughs in cell, module, and system technologies to a probing look at important environmental, health, and safety issues in the photovoltaic industry, it covers a broad range of topics of vital interest to solar cell researchers, power systems designers, and all those with professional interest in current and future capabilities of this important technology. Offers a detailed look at cutting-edge solar technology from an international team

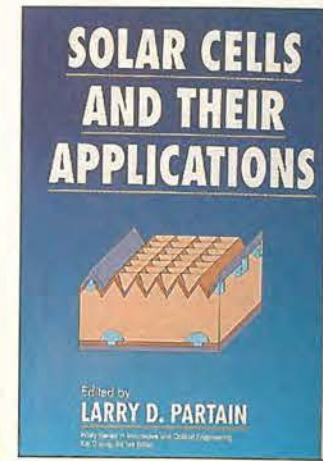

of researchers. Covers silicon, GaAs, InP, CdTe, a-Si:H, CuInSe₂ and GaSb solar cells, cells, concentrators, multijunction cell configurations, space cells, and more. Describes a wide range of applications - from space cells to terrestrial systems. Provides an informal look ahead at the future of solar cell technology.
0471 574201, 596pp,
UK £71.50, Europe £75.00, ROW £92.00

Introduction to High-Speed Electronics and Optoelectronics

Lasers, fibre optics, and high-speed optical systems share many concepts with microwave devices. Furthermore, semiconductor-based optoelectronics and microwave integrated circuits share evolving process technologies. It is only natural, therefore, that students of optoelectronics be introduced to high-speed concepts in a unified manner. This highly practical intensive introduction enables electrical engineers, applied physicists, and students to develop and identify tools for understanding, analysis, design, and characterisation of high speed components. Broad in scope, this unique

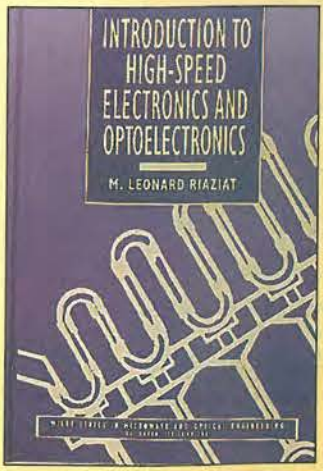

text/reference examines the complementary nature of electronics and optics and emphasizes high-speed technology in which the two fields are less differentiated. Beginning with an overview that develops a perspective and appreciation of analog high-speed technology in general, the book goes on to cover devices and circuits used at microwave and millimeter-wave frequencies, optical components, and optoelectronic integrated circuits and subsystems. Particular attention is paid to applications in the area of high levels of interest in this area and because many of the concepts are applicable in other fields. The book concludes with important coverage of the often-overlooked area of measurement and characterization of high-speed devices. Fully referenced and supplemented with hundreds of helpful illustrations, *Introduction to High-Speed Electronics and Optoelectronics* is equally useful as a professional reference or a textbook for senior undergraduate and first-year graduate courses.
0471 015822, 312pp,
UK £65.00, Europe £67.00, ROW £77.00

Risc Systems and Applications

Professor Daniel Tabak has completely revised and updated his two previous books on Reduced Instruction Set Computer architecture to produce this new book, RISC Systems and Applications. The text is a unique, concentrated, detailed description of the architecture and implementation of most recent high-performance RISC systems, such as DEC Alpha AXP21164, IBM/Motorola/Apple PowerPC 620, Sun Microsystems and Texas Instruments UltraSPARC and SuperSPARC, MIPS technologies R10000, Intel i860 XP, Motorola MC88110, Hewlett-Packard PA-7100/8000 and the transputer. It also includes details of pioneering devices such as Berkley's RISC II and Stanford's MIPS and multiprocessor, real-time and workstation systems.
ISBN 0863 801889, 452pp,
UK £50.50, Europe £54.00, ROW £67.00

All prices are fully inclusive of packing and delivery

Return to Jackie Lowe, Room L333, Quadrant House, The Quadrant, Sutton, Surrey, SM2 5AS

Please supply the following titles:

Qty	Title or ISBN	Price

** All prices on these pages include delivery and package **

Total _____

Name _____

Address _____

Postcode _____ Telephone _____

Method of payment (please circle)

Access/Mastercard/Visa/Cheque/PO

Cheques should be made payable to Reed Business Publishing

Credit card no. _____

Card expiry date _____

Signed _____

Please allow up to 28 days for delivery

On beating frequencies

In the September 1997 issue on page 786, Chris Bulman raised a question about beating frequencies. This query prompted an unusually high response. These are the last few responses that we are able to publish on the subject, but many thanks to everyone who replied. Ed

Chris Bulman is correct in thinking that a sinewave signal very close to the Nyquist frequency will, when sampled, produce a set of data points which encode a "wuhwuhwuh" (sic).

Fourier analysis of the wuh (forgive the abbreviation) would show in his example at 19.999kHz and one at 20.001kHz. There are also pairs of tones at 59.999k/60.001k and all subsequent odd multiples of the Nyquist frequency, with gradually reducing amplitude.

If you fed the data to a d-to-a converter and listened to the output, I'm sure those with a reliable aural response to 20kHz would hear this pulsating effect.

But this is not what happens in a proper digital audio system. A proper system uses an anti-imaging filter whose primary role is to remove the higher of the wuh tones, leaving the lower one pristine, smooth and un-wuhed.

This filter would indeed have a delay of many seconds if it had to resolve the 2Hz frequency difference between the wuh tones, which is why a 'guard band' is used between the highest encoded frequency and the Nyquist frequency. It makes the anti-imaging - as well as the anti-aliasing - filters economically realisable, whether they are 'traditional' analogue or computational exercises in silicon.

Kendall Castor-Perry, Kemo Ltd, Kent

Chris Bulman asks about the behaviour of a digital sampling system, and the effect on it of signals at or close to the Nyquist frequency - i.e. half the sampling frequency.

In his example, Chris Bulman explains that a signal at 19.999kHz passed through a system that is sampling at 40kHz, and has a brick-wall filter that cuts off at 20kHz, will result in the d-to-a converter producing a 20kHz signal that is modulated at 1Hz, reversing in phase every half cycle. He believes his analysis of the signal, but does not believe that this is what really happens, and would like a non-mathematical explanation of the paradox.

A simple argument is to observe that Chris's waveform is a 20kHz signal modulated at 1Hz. Since modulation produces sidebands, this signal is impossible, as the brick wall filter removes sidebands above 20kHz.

A more complete answer to the paradox (but unfortunately requiring a small amount of maths) is as follows:

Chris's description of the signal is in fact a correct one if the brick wall filter is ignored. Ignoring the brick wall filter has no effect on Chris's argument, except that signals appear around a series of harmonics of the 40kHz sampling square wave.

The signal as described, viz. a 20kHz signal modulated at 1Hz, reversing in phase every half cycle, is actually a suppressed-carrier, double-sideband signal. In this case, the sidebands are 1Hz either side of the suppressed 20kHz carrier at 19.999kHz and 20.001Hz.

A way of understanding this is to look at it the other way round: there are two sidebands, and they are beating together. To find out

what happens when two sinusoidal signals are added together, consult an A-level maths book, where you will find the identity,

$$\cos A + \cos B = 2 \left[\cos \left(\frac{A+B}{2} \right) \cos \left(\frac{A-B}{2} \right) \right]$$

which is also known as 'two cos semi-sum cos semi-diff.'

This formula shows that sinusoidal waves of 19.999kHz and 20.001kHz will beat together to give a result that is a 20kHz sinusoidal wave (the $\cos(A+B)$ term) multiplied by a 1Hz sinusoidal wave (the $\cos(A-B)$ term), which is the waveform originally described by Chris.

Once you realise that C.B.'s fluctuating signal is actually a pair of frequencies, then all you have to do is put the brick-wall filter in, and, since it removes everything above 20kHz, what is left is 19.999kHz, as per Nyquist's theory. The 20.001kHz signal that has been removed is known as an alias signal.

Incidentally, a true brick wall filter is impossible to realise. The more brick-wall-like a filter is, the more delay the filter have, and an infinitely steep brick-wall response would require an infinite delay. However, replacing the brick-wall filter with a real filter, and leaving a guard band between the highest signal frequency and the Nyquist frequency, as is done in practice, does not in any way alter the paradox as described by Chris, and its explanation as given above, since the delay in the filter - ideally - affects all frequencies by the same amount.

Brian Pollard
Maidstone
Kent

rejects higher ones: in particular, it must pass 19.999kHz and reject 20.001kHz.

Can this be done in practice? In practice the window length is restricted to, perhaps, 100ms. This gives a selectivity of 0.01kHz, and so if 19.999kHz is to be passed then 20.001kHz will come through as well.

Having established that a practical reconstruction contains both the desired sinusoid and its first alias, it is easy to see what happens: the two frequencies beat together in the way that Mr Bulman describes. Note that the beat frequency does not actually occur in the spectrum - though if the signal were nonlinearly distorted it would. The problem will not arise if the difference between the signal and Nyquist frequencies is reasonably large - perhaps 1kHz -

because then the signal's aliases can be removed very effectively.

It is therefore a good idea, once the sampling rate has been selected as 2W, to remove all frequencies above rW (for some r less than 1) before sampling. This creates a guard band between the highest frequency present, rW, and the Nyquist frequency, W, and makes accurate reconstruction a much more practical proposition. Helms and Thomas were the first to discuss this in a classic paper² on rapidly-convergent sampling expansions; since the sampling expansion gives the filter weights, their work is of immediate relevance in the design of reconstruction filters.

Richard Martin
GEC Marconi Research

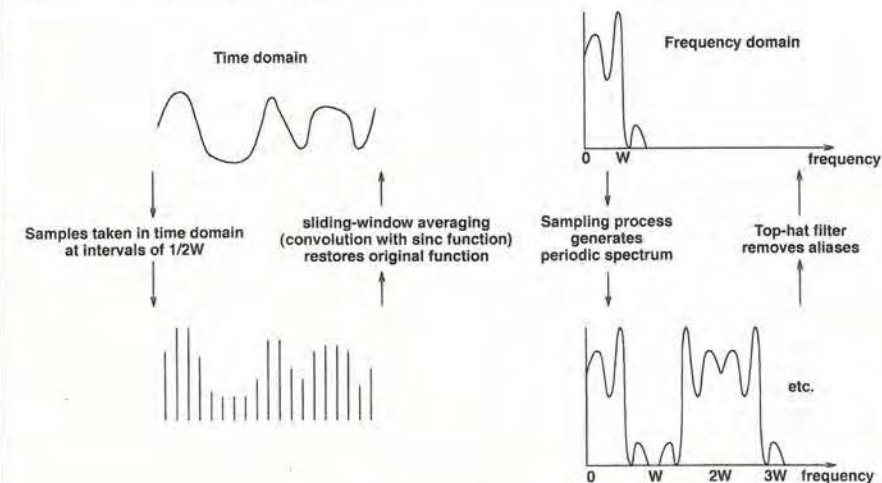

CLASSIFIED

TEL 0181 652 3620

FAX 0181 652 8956

ARTICLES FOR SALE

PCB CAMERA £39.00+VAT B/W MODULES

32mm. 3.5 lens or pinhole £39.00 + vat each
42mm • lens with audio add £10 + vat
(UK CARRIAGE/PACK/INSURANCE £4 UP TO 10 PIECES)

DISCOUNT FOR QUANTITIES

SEE OUR WEB SITE
OPEN 6 DAYS A WEEK FOR CALLERS
MAIL-ORDER OR EMAIL

HENRY'S 404 EDGWARE ROAD
LONDON W12 1ED

Tel: 0171 258 1831 Fax: 0171 724 0322
email: sales@henrys.demon.co.uk internet address: http://www.henrys.co.uk

AUDIO & RF DESIGN - DC to 3GHz

- ◆ Stereo Coders & processors
- ◆ RF Amplifiers & Transmitters
- ◆ Wireless Control Systems
- ◆ 2.4 GHz Audio & Video Links
- ◆ Aerial combining Systems

So whatever your need call us!
LIBRA SOLUTIONS
Tel: 0181-428 2776
mnoar@globalnet.co.uk

Surplus Stock - Capacitors

Large volume availability of capacitors direct from manufacturer in pitch sizes 5, 7.5 & 10. VDC 63, 100, 250, 400 & 630. μ F 0.001 - μ F 0.68

For further details please contact:
Pala Capacitors
Tel: 01483 565090
Fax: 01483 566050

RF DESIGN SERVICES

All aspects of RF hardware development considered from concept to production.

WATERBEACH ELECTRONICS

TEL: 01223 862550
FAX: 01223 440853

SALE - INDUSTRIAL ELECTRONICS

Test equipment, Transducers, Valves, Connectors, Computers, Analysers, Components, Gauges, Meters, Printers, Rummage items, HP, Racal, IBM etc. Near Southampton, 12-13 December

Technical and Scientific Supplies
Tel: 01703 891879 Fax: 01703 897079
e-mail: tjs@compuserve.com

MICRO CCD CAMERA

High definition and sensitivity
>380 lines < 0.1 Lux 92 deg. lens
1/3" b/w PCB, 12V 75mA
38*38*30mm
Standard 1 Volt 625 line video o/p.

ONLY £64.95
inc uk. p&p, and VAT
Send cheque or PO. to
ReTech Ltd., Unit 1,
Dorcan Business Village,
Swindon, SN3 5HY.
Send sac, for details and latest
list of AV. and Satellite offers

AUDIO & RF DESIGN - DC to 3GHz

- ◆ Stereo Coders & processors
- ◆ RF Amplifiers & Transmitters
- ◆ Wireless Control Systems
- ◆ 2.4 GHz Audio & Video Links
- ◆ Aerial combining Systems

So whatever your need call us!
LIBRA SOLUTIONS
Tel: 0181-428 2776
mnoar@globalnet.co.uk

INTERESTED IN A HIGHER DEGREE?
Why not read, *Gaining a Master's Degree* by
Allen Brown. Available from book shops or
HowToBooks, Plymouth House, Estover Road,
Plymouth PL6 7PZ. Tel: 01752 202301, Fax:
01752 202301, £9.99.

**PLEASE MENTION
ELECTRONICS WORLD
WHEN REPLYING TO ADVERTISEMENTS**

CAPACITORS

Large volume availability of capacitors direct from manufacturer in pitch sizes 5, 7.5 & 10. VDC 63, 100, 250, 400 & 630. μ F 0.001 - μ F 0.68

For further details please contact:
PALA CAPACITORS
Tel: 01483 565090
Fax: 01483 566050

DAT RECORDER Sony Portable TCD-D8 £299 (half new price), boxed in perfect condition. Used for 2 hours only. Telephone: (01904) 426696 (Evenings).

Adret 740A Signal Generator 0.1 - 1120 MHZ

Price: £1,500

TELFORD ELECTRONICS
(0044) 01952 605451

FLUKE 867B graphical multi meter, five months old, with leads and manual: £550 ono. Tel: 01482 815625.

JRC RADIO TEST SET NJZ 900E. £450. Tel: 01635 552285.

ARTICLES WANTED

VALVES and CRTs AVAILABLE

ONE MILLION VALVES stocked for Audio, Receiving, Transmitting & RF Heating. Rare brands such as Mullard & GEC available. Also MAGENTRONS, KLYSTRONS, CRTs and SOCKETS.

Large stocks of Russian and Sovtek items.
Please ask for our free catalogues of valves or CRTs.

VALVES, etc, WANTED

Most types considered but especially KT88 (£60), PX4/PX25 (£60), KT66 (£38), KT77 (£18), EL34 (£15), EL37 (£15), ECC83 (£3). Valves must be UK manufacture to achieve prices mentioned. Also various valve-era equipment e.g. Garrard 301, (up to .£80). Ask for a free copy of our wanted List.

BILLINGTON EXPORT LTD., Billingshurst, Sussex RH14 9EZ
Tel: 01403 784961 Fax: 01403 783519
VISITORS STRICTLY BY APPOINTMENT. MINIMUM ORDER £50 plus VAT

TOP PRICES PAID

For all your valves, tubes, semi conductors and IC's.

Langrex Supplies Limited
1 Mayo Road, Croydon
Surrey CR0 2QP
TEL: 0181-684 1166
FAX: 0181-684 3056

WANTED - Old cipher equipment and "spy radio sets". 0Z8RO Rag Otterstad, Hosterkobvej 10 DK-3460 Birkerød, Denmark. Fax: ++45 44681514.

WANTED - W.W.II. German and S.O.E. clandestine sets, receivers. Also incomplete sets. 0Z8RO Rag Otterstad, Hosterkobvej 10 DK-3460 Birkerød, Denmark. Fax: ++45 44681514.

WANTED - any AVO model 8 with hopelessly damaged movement. Tel: 01326 312901.

SWITCHING PSU REQUIRED? Surf: www.directou.mcmil.com Loads'a bargains.

RECRUITMENT

SALES MANAGER

We are a small company supplying transmission systems to the broadcast radio market and are looking for a Sales Manager to take over the running of our sales department. You should have a technical background, ideally with some experience of radio.

Please apply with letter and CV to:
Alan Brown, Radica Broadcast Systems Ltd.,
18 Bolney Grange Industrial Park, Hickstead,
Haywards Heath, West Sussex, RH17 5PB

Grad/Engineer/Leader/Manager

Senior RF Engineer

This leading Radio design company who is focused on the automatic meter reading (AMR) market is leading the way in AMR throughout Europe and beyond. You will lead up a team of strong Engineers who have the desire to be part of the successful team. You will also play a key role in the European equipment range and laboratories. Ideally you will come from a comms background and be educated to Degree level with the minimum of five solid years in RF design in a management or supervisory role. This is an excellent opportunity for a talented and ambitious Engineer to join a worldclass RF design company which offers an outstanding allround package - grab this one with both hands!

David Tillyer - Ref: DT112/EWo

Driving Technology

Essex
We are looking for a number of good academic Engineers (2.2 Honours or better) to join the Audio, Power Train, Body Electronics and In-Car Control Systems depts of a well known automotive manufacturer. You will join multi-discipline teams working on NEW European and Worldwide commercial vehicles projects to go into production at the turn of the Century. We are keen to talk to Engineers with a good Degree, at least 12 months in industry plus experience of digital/microprocessor and/or analogue electronics. Experience of automotive, electronics, control systems, powertrain, audio, instrumentation or sensors would also be useful. Please call for further details.

Andrew Langridge - Ref: AL426EWo

Peter Gabriel Has One !..

So does Phil Collins, Sting and the BeeB to "name drop" just a few customers - we are talking serious SOUND MIXING! To continue their success in the professional audio and broadcast arena, this company have an URGENT requirement to recruit innovative, practical, team minded Design Engineers who don't mind dabbling in a mixture of: Hardware, FPGA's, Analogue etc, etc. We need to talk to you, if you have a hobby or interest in electronics, are a hands-on Engineer, you want to engineer, and you want your electronics to work!

Andrew Langridge - Ref: AL424EWo

Power Supply/Electronics

Snr PSU Designer	Slough	£30K
2yrs+ SMPS	Suffolk	£26K
Power Supply - Avionics	Middd	£18-26K
PSU's, TVs	Midlands	£open
Hi Voltage PSU	S Coast	£28K
Commercial SMPS	Devon	£28K
R&D SMPS	Herts	£25-30K
DC Power Systems	Essex	£28K
SMPS/PSU	Scotland	£30K
SMPS/Avionics	Camb	£29K

Andrew Langridge - Ref: AL420EWo

Test Development Team Ldr - Radio/RF

N.Home Counties
A leading systems/board level development house responsible for R&D activities into the PMR/Radio field require a Test Equipment Team Leader. You will be responsible for the co-ordination of a small Test Development Team, project managing new developments, also acting as a functional part of the team - yourself being involved in Test Development activities. You will liaise with R&D on DFT/ Testability issues and on determining test strategies. HND/Degree Electronics, 5 years+ test development experience, knowledge of I/O interfaces, IEEE-488, RS232, HPBASIC/QUICKBASIC, RF/Radio principals.

Peter Starling - Ref: PS200EWo

RF, RF, RF

RF Design	Hampshire	£18-40K
RF/GSM Design	Wiltshire	£25-30K
RF and System	Hampshire	£24-37K
RF Test	Hampshire/Bucks	£15-25K
RF Planner	Middlesex/Wiltshire	up to £27K
RF Support/Design	USA	up to £40K+ bens
RF Systems/Test Engineer	Cambridgeshire	£25K+ Car
Senior RF Engineer	Herts/Berkshire	up to £40K

David Tillyer - Ref: DT136/EWo

RF/MW Eng Mgr - RF/MW Comps/Modules

c£40K
A company involved in the design/development of Microwave/RF components require an Engineering Manager. You will be responsible for determining the current and future direction of Product Development, you will setup and co-ordinate dedicated Development Teams in the development of components/modules for markets aimed at the Satellite/Wireless Comms, Space and Automotive industries. You will liaise with Marketing/Sales functions in the definition of future product direction. Degree qualified, 10 years+ in a Senior Engineer/ Product Development role, vast experience in RF/MW component development, project management.

Peter Starling - Ref: PS202EWo

Graduates of '96 & '97

2:2/2:1/1st/MSc/ PhD
Top companies who offer superb salaries, career prospects and training are now looking for bright articulate and ambitious graduates to join them. If you are experienced in:

* Power	* Comms	* Telecomms
* RF	* DSP	* Audio
* ASIC/C	* VHDL	* Imaging
* Control	* Automotive	* Instrumentation
* Analogue	* Digital	* Optoelectronics

We offer excellent opportunities. **Caroline Papp - Ref: CP01EWo**

Development Engs - Video/RF

N.Home Counties
A company who design/develop and manufacture network broadcast equipment primarily for the Cable/Consumer Network industry require Design Engineers. You will be responsible for the development of Video and RF circuits for consumer based products. You will take product development from conception to manufacture and will liaise with other parties along the way to ensure DFM/DFT criteria are met. HND/ Degree Electronics, component level design (Video/RF), use of design tools - PSPICE etc, knowledge of Set Top Box/Cable TV products an advantage.

Peter Starling - Ref: PS190EWo

DSP Engineers

Continuing European growth has led to the immediate requirement for a couple of good all-round DSP Engineers to join this small interactive team. You will be responsible for Hardware and Software Design (algorithm design, coding and testing) used in the development of new GSM and PMR comms products. Experience, allied to a degree level qualification should include real-time embedded software experience in C/C++ and Assembler with solid exposure to Texas DSPs.

Frazer Martin - Ref: FM/EWo70

Software Test

Testing times indeed! We can't find enough good experienced Software Test Engineers, therefore we have numerous vacancies from Junior to Team Leader level with clients in Telecomms, Datacomms and Consulting industries. Their requirements are similar, in that they all seek qualified, well trained Engineers to take responsibility for this critical production area, whether you have just one years experience or whether you develop test strategy, enhancements, procedures and seek a move into Consultancy - we have probably got a good move for you.

Frazer Martin - Ref: FM/EWo753

Fraud/Security Systems

As part of this major network provider/operator you will be responsible for the design/ integration of security and fraud systems into the existing comms infrastructure. You should possess a good knowledge of systems and protocols, encryption and authentication techniques. Additional exposure to GSM or RF would be advantageous.

Frazer Martin - Ref: FM/EWo40

Software Tools/Billing/CTI

The UK's most popular Mobile Telecomms company require talented qualified Engineers to join them in developing software tools for their next generation GSM cellular systems, CTI, business critical software, designing subscriber admin/billing systems software or simply planning/optimisation tools for their new and current networks. You will have a good Degree plus experience of development in C, C++, OOA/D, RDBMS.

Frazer Martin - Ref: FM/EWo63

Development Manager

Our client is a leading blue chip company who require an experienced Development Manager. Based in Hampshire you will be developing a wide range of satellite based (GPS) positioning and using a range of communication systems including RF tagging products. You will also be involved in taking the designs through the complete product lifecycle and have some contact with customers and supplier. You will be qualified to Degree level in Electronics and/or will have a background in analogue and digital design and some knowledge of embedded microcontroller firmware design, a good allround package is offered to the ideal candidate.

David Tillyer - Ref: DT115/EWo

Midlands

£16-28K
Various companies in the East and West Midlands have a number of openings for Hardware Engineers with digital and analogue skills in the following fields:

* Medical	* Automotive
* Instrumentation	* Avionics
* Power	* ASIC/C Design

Roma Das Gupta - Ref: RDG29EWo

Cash

World leader in the provision of transaction products and services based in the South of England are looking for Digital and Analogue Electronic Engineers at all levels. Digital position requires electronic design experience with 16/32 bit embedded microcontrollers, analogue position requires experience with low noise circuits, analogue circuit simulation and some knowledge of sensors. All positions require a good Degree and knowledge of EMC with software experience in assembler and C. Excellent company with benefits to match.

Roma Das Gupta - Ref: RDG20EWo

Design Engineer

East
A leader in the field of medical instrumentation is looking for a Hardware Design Engineer to develop new ideas. The company who are based in the East of England have just received a SMART grant to produce state-of-the-art medical equipment. The successful candidate must be prepared to work in a hands-on role, individually and as part of a team. We'd be keen to talk to Engineers with experience of digital and/or analogue hardware in addition instrumentation/laboratory equipment experience would be an advantage.

Roma Das Gupta - Ref: RDG25EWo

Please call quoting the appropriate Ref. No. on **01442 212555** or fax/email/post your CV to:

	2nd Floor, 89 The Marlowes, Hemel Hempstead, Herts, HP1 1XY
Tel: 01442 212555 Fax: 01442 231555	email: swprecruit@dial.pipex.com (preferably WORD format please)

R&D

Telecomms Systems

E. Midlands **£20-35K**
Fast expanding internet company but small close knit group. You shall have wide systems experience in elite switching networks or mobile radio. Some UK travel is necessary. This is a good move from a pure technical role to a more commercial and customer focused activity.

Contact: Gordon Short

Ref: GS4900

Research Assistant

Bucks **to £30K**
International standards and consultancy between design groups require an understanding of protocols and the ability to travel. You may be a research assistant in Telecommunications looking for your first career or you may already be established in switching, GSM or broadband systems. You will become the acknowledged company expert in your field.

Contact: Gordon Short

Ref: GS4901

Low Noise Amplifier Hardware Design

Hants/Bucks **£18-38K**
Whatever your RF skills or experience, our client will train you to do better. Worldwide projects include fixed access and satellite communications. Working at circuit, systems or advanced research level you will join a young dynamic team set to produce equipment to celebrate the millennium!

Contact: Gordon Short

Ref: GS4902

ASIC

ASIC Design

UK Wide **to £50K & Benefits**
Exceptional opportunities with major semi-conductor companies, electronic manufacturers and design consultancies. The following skills are in high demand VHDL, VERILOG, CADENCE, SYNOPSIS, MOS/BIPOLAR technology etc. Applications include Telecoms, Datacoms, Video/TV, Multimedia etc. Vacancies at all levels from Graduate to Project Leader some involving UK/European travel.

Contact: Brian Cornwell

Ref: BC4903

Mixed Signal Designer

M3 **c£28K**
With this company only 2 years Analogue/Mixed Signal design will give you real responsibility and career development opportunities. If you have transistor level CMOS, BICMOS or Bipolar design experience with Mentor, VHDL, PSPICE, ELDO, LEDIT or Sabre skills phone me NOW!

Contact: Brian Cornwell

Ref: BC4904



Communications

Ambassador House
575-599 Maxted Road
Hemel Hempstead
Herts HP2 7DX

Telephone (days): 01442 231691

Eves/wkends: 01442 253300

Fax: 01442 230063

Email: executive@dial.pipex.com

Web: http://www.ers.co.uk/ers

A member of Executive Recruitment Services plc group of companies

T & M EQUIPMENT



ADVANTEST R3762AH 3.6GHz vector network analyser £5000
 ANRITSU ML93A optical power meter (MAR96A 0.75-1.8uM) £1000
 ANRITSU MS420B 10Hz-30MHz network/spectrum analyser 75 ohms £3000
 ADVANTEST TR9407 ft spectrum analyser to 1MHz £3500

BRADLEY 192 oscilloscope calibrator £500
 HP8720C/6/10 microwave vector network analyser £4000
 HP35660A dynamic signal analyser, with 01 option £5000
 HP8753C vector network analyser with 6GHz option £2500
 HP182T/8559A 21GHz spectrum analyser £3500
 HP3582A dual channel ft analyser £2500
 HP54620A 15 channel 500MS/sec logic analyser £1250
 HP83475A lightwave communications analyser £3250
 HP8357A sweeper plug-in (for 8350B) covering 26.5-40GHz £7500
 HP8557A/182T 350MHz £1000
 HP8591E 1.8GHz portable, 75ohm option 01 and TV option 301 £4000
 HP8756A scalar network analyser £1250
 MARCONI 2019 synthesized signal generator 80kHz-1040MHz £1750
 MARCONI Z380/Z382 high specification, 400MHz spectrum analyser £4500
 FARNELL AP70-30 power supply 0-70V 0-30A 500W £650
 FARNELL SSG2000 10Hz-2GHz synthesized signal generator £2000
 PHILIPS PM5193 synthesized function generator £2000
 SCHAFFNER NSG500C/506C interference generator £3500
 SCHLUMBERGER 7081 8.5 digit precision voltmeter £1500
 WANDEL & GOLTERMANN PCM44 test set £15K
 WILTRON 560A scalar analyser, 6647B sweeper, 6669A sweeper Call

ralfe electronics exclusively professional T&M ID
 36 Eastcote Lane South Harrow Middx HA2 8DB England
 TEL (+44) 0181-422 3593 FAX (+44) 0181-423 4009

EST 45 YRS

DISTRIBUZIONE E ASSISTENZA, ITALY: TLC RADIO, ROMA (06) 871 90254



HEWLETT PACKARD



1640B serial data generator £500
 11581A attenuator set £350
 3338A synthesizer/level generator £2000
 3235A switch/test unit £1000
 3325A synthesized function generator /01/02 £1500
 33320G/33322G programmable attenuators 4GHz, with driver 11713A £1000
 As above but 18GHz set £1500
 35650A mainframe £2000
 E3615A bench power supply £175
 37724A/04 digital hierarchy test set £9500
 37900D signalling test set with 2 x 37915A interface cards £5500
 4140B pA/meter, DC voltage source £4000
 4275A multi-frequency lcr meter £3000
 4948A (/04) in-service TIM set £500
 4093B protocol tester base (PT300) £3500
 545100A 1GHz digitizing oscilloscope, now inc 2 x 1GHz active probes £1500
 54620A logic analyser £1200
 6633A systems power supply £600
 8018A serial data generator £1000
 8082A pulse generator 250MHz £2000
 8111A pulse generator 20MHz £1250
 83411C lightwave receiver 1300/1550nm £1750
 83440C lightwave detector 20GHz 1300/1550nm £2000
 8350B with 83592A 10MHz-20GHz sweep generator £ call
 86222A/8620C 10MHz-2.4GHz sweep generator £1500
 87510A gain-phase analyser 100kHz-300MHz £6500
 8901B modulation analyser £4500
 J2215A FDDI portable multimode test set £1500
 J2304 internet advisor with ethernet interface £2500

TEST EQUIPMENT

★ URGENTLY REQUIRED ★
 HEWLETT PACKARD 8720 series network analysers £20,000+paid for 'C'
 HEWLETT PACKARD 8510 series microwave analysers, anything considered
 HEWLETT PACKARD 8566B series spectrum analysers £10K-£20K paid
 HP8753C + vector network analysers, we pay top prices for late models.
 Guaranteed top prices paid for all current model spectrum/network analysis.



ISO9002 ACCREDITED STOCKIST MEASUREMENT & TEST EQUIPMENT

FOR EXCLUSIVE ACCESS TO OUR COMPLETE STOCK INVENTORY AND SPECIAL BARGAIN DISPOSAL DEALS PLEASE CHECK OUR WEBSITE <http://www.ralfe-electronics.co.uk>

CIRCLE NO. 139 ON REPLY CARD

ELECTRONIC UPDATE

Contact Joanna Cox on 0181-652 3620

A regular advertising feature enabling readers to obtain more information on companies' products or services.



PXI Modular Instrumentation
 PXI delivers the high-precision instrumentation, synchronisation and timing features of more expensive platforms at an affordable price. Combining mainstream PCI computing technology and Windows software with rugged industrial packaging. PXI offers high performance test, measurement, data acquisition and industrial computing solutions.
 For your free brochure call National Instruments on: 01635 523545



New for '97 Free Data Acquisition Software Tool
 DAQ Designer 97 is a free system configuration software tool for the PC that takes you through your application step-by-step, asking you questions, and recommending all the right equipment, including: PC plug-in DAQ boards, PCMCIA DAQ cards, Signal Conditioning and Sensor Interfacing, Cabling and Software.
 Call National Instruments for your free copy on (01635) 523545
 CIRCLE NO. 141 ON REPLY CARD

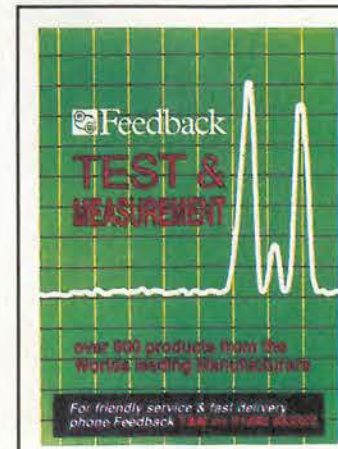

NEW Feedback T&M Catalogue
 The latest edition of the Feedback Test & Measurement catalogue is now available. Over 60 pages packed with more than 800 products divided into over 20 sections. The catalogue is indexed for both product and manufacturer and is fully illustrated. Whether you are looking for an individual product, a complete workstation, or a solution to a particular Test & Measurement need the NEW Feedback catalogue will solve your problems, send for a copy NOW!
 CIRCLE NO. 142 ON REPLY CARD

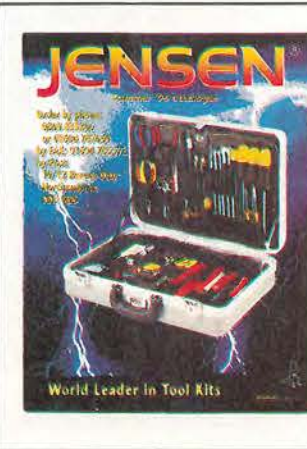

NEW JENSEN TOOLS CATALOGUE
 Colourful new Catalogue, hot off the press from Jensen Tools, presents unique new tool kits for service/support of communications equipment. Also latest test equipment from many major manufacturers. Includes hard-to-find tools, PC/LAN diagnostics, bench accessories, static control, technical manuals and more.
 Ring 0800 833246 or Fax 01604 785573 for a free copy.
 Jensen Tools, 10-12 Ravens Way, Northampton NN3 9UD
 CIRCLE NO. 143 ON REPLY CARD

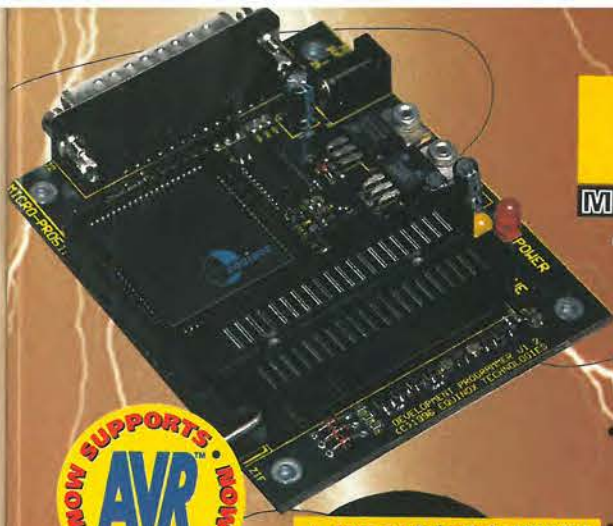

£149.00 Order Code: MPW-SYS



The Ultimate 8051 Microcontroller Programmer

- Supports Atmel FLASH 89C +89S, Generic 87C51/52/FA/FB/FC microcontroller derivatives
- FLASH & E2 libraries also available as chargeable update

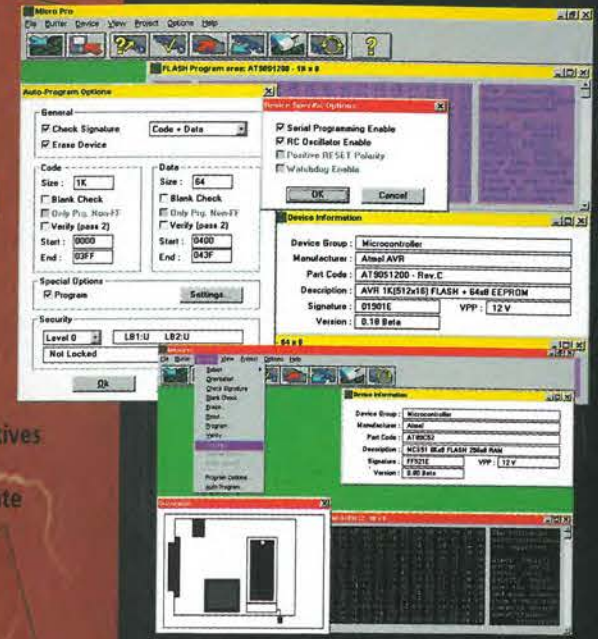

The above software is now available with all our programmers featured in this ad

AVR™ Professional Starter System

- Features:**
- Supports programming of Atmel 90S(AVR) microcontroller families
 - Supports both Parallel and Serial programming modes

Comes complete with:
 Serial programming cable, AT90S1200 microcontroller, assembler, CD ROM Databook, Parallel cable and Power supply

£59.95 Order Code: AVR-ST



Serial Programming System

"Now you can program the 8051

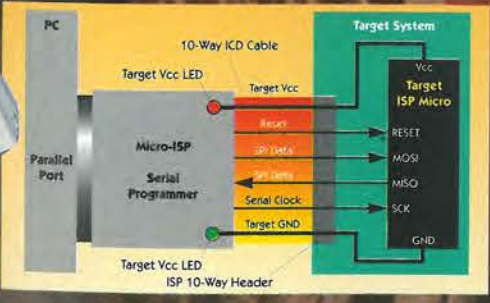

£39.95 Order Code: UI5P-V2-SYS

without removing the device from the socket!"

89S Socket Stealer Module

Simply plug this into your existing 8051 or AVR socket for INSTANT In-System Programming NO Target System redesign required. £49.00 Order Code: SS-89S-DIL40



The Embedded Solutions Company

PROVIDING THE SOLUTIONS TO YOUR PROBLEMS!

For product information visit our web site at: www.equinox-tech.com
 E-mail: sales@equinox-tech.com
 229 Greenmount Lane Bolton BL1 5JB UK

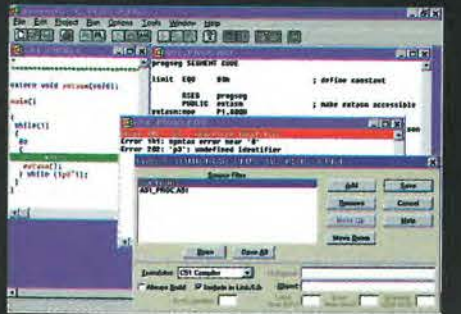

A comprehensive range of 51 Starter & Development Systems are also available

EQUINOX DISTRIBUTORS: BELGIUM Alcom Electronics NV/SA +32 3 458 30 33 ENGLAND Abacus Eiger +44 1925 626626, Farnell Components +44 1132 790101, GD Technik +44 1734 342277, Rapid Electronics +44 1206 751166, Quarndon Electronics +44 1332 332651 FRANCE Newtek +33 1 4687 2200 GERMANY Ineltek GmbH +49 7321 93850, MSC Vertriebs GmbH +49 08 9945532 12 GREECE Microlec +30 1 5395042 4 ITALY Grifo Italian Technology +39 51 89 20 52, Newtek Italia +39 2 33 10 53 08 NETHERLANDS Alcom Electronics BV +31 10 4519533, NORWAY ACTE NC Norway +47 63898900, Jakob Hatteland Electronic AS +47 53763000 PORTUGAL Anatomic +35 119 371 834 SPAIN Anatomic SA +34 1 366 01 59 SWITZERLAND Anatec Ag +41 41 748 32 41 USA Hitools Inc +1 408 298 9077, Peachtree Technology +1 770 888 4002

Equinox reserves the right to change prices & specifications of any of the above products without prior notice. E&OE. All prices are exclusive of VAT & carriage. AVR™ is a trademark of the Atmel Corporation

Surely not. Surely someone somewhere has developed a portable programmer that has even more features, even greater flexibility and is even better value for money.

Actually, no. But don't take our word for it. Use the feature summary below to see how other manufacturers' products compare.

Dataman-48LV

- Plugs straight into parallel port of PC or laptop
- Programs and verifies at 2, 2.7, 3.3 and 5V
- True no-adaptor programming up to 48 pin DIL devices
- Free universal 44 pin PLCC adaptor
- Built-in world standard PSU - for go-anywhere programming
- Package adaptors available for TSOP, PSOP, QFP, SOIC and PLCC
- Optional EPROM emulator



Money-Back 30-day Trial

If you do not agree that these truly are the most powerful portable programmers you can buy, simply return your Dataman product within 30 days for a full refund

Enq no 179

30 FREE DAY TRIAL powerful, portable programmers

free software

upgrades +

technical support

for life

3 year GUARANTEE

Support

- 3 year parts and labour guarantee
- Windows/DOS software included
- Free technical support for life
- Next day delivery - always in stock
- Dedicated UK supplier, established 1978

Dataman S4

- Programs 8 and 16 bit EPROMs, EEPROMs, PEROMs, 5 and 12V FLASH, Boot-Block FLASH, PICs, 8751 microcontrollers and more
- EPROM emulation as standard
- Rechargeable battery power for total portability
- All-in-one price includes emulation leads, AC charger, PC software, spare library ROM, user-friendly manual
- Supplied fully charged and ready to use

S4 GAL module

- Programs wide range of 20 and 24 pin logic devices from the major GAL vendors
- Supports JEDEC files from all popular compilers

Still as unbeatable as ever!

Beware of cheap imitations. Beware of false promises. Beware of hidden extras.

If you want the best, there's still only one choice - Dataman.

Order via credit card hotline - phone today, use tomorrow.

Alternatively, request more detailed information on these and other market-leading programming solutions.

DATAMAN

Dataman Programmers Ltd, Station Road, Maiden Newton, Dorchester, Dorset, DT2 0AE, UK

Telephone +44/0 1300 320719

Fax +44/0 1300 321012

BBS +44/0 1300 321095 (24hr)

Modem V.34/V.FCV.32bis

Home page: <http://www.dataman.com>

FTP: [ftp.dataman.com](ftp://ftp.dataman.com)

Email: sales@dataman.com

CE

£495 PLUS VAT



hotline
01300 320719



Orders received by 4pm will normally be despatched same day.
Order today, get it tomorrow!

CREDIT NO. 104 ON REPLY CARD